

CONTENTS

HAWAU-T-89-002 C3

**Description and Economic Analysis of Intensive  
Marine Shrimp Culture in Taiwan and  
Simulated Technology Transfer to Hawaii in 1985**

FOR OFFICIAL USE ONLY

**DESCRIPTION AND ECONOMIC ANALYSIS OF INTENSIVE MARINE  
SHRIMP CULTURE IN TAIWAN AND SIMULATED  
TECHNOLOGY TRANSFER TO HAWAII IN 1985**

**CIRCULATING COPY  
Sea Grant Depository**

Arlo W. Fast  
Y. C. Shang  
I. Chiu Liao  
Gary L. Rogers

June 1989

UNIHI-SEAGRANT-MR-89-02  
UH Sea Grant College Program  
Honolulu, Hawaii

\$ 9.00

NATIONAL SEA GRANT DEPOSITORY  
FEDERAL BUREAU OF INVESTIGATION  
COLLEGE PARK, MARYLAND 20740  
PHONE (301) 554-3322



This miscellaneous report is the result of research (project PM/M-1BB3, "Economic Analysis of Intensive Marine Shrimp Culture Systems in Taiwan, and Simulated Transfer to Hawaii") funded by the University of Hawaii Sea Grant College Program under Institutional Grant No. NA81AA-D-00070 from NOAA Office of Sea Grant, U.S. Department of Commerce. This report was published by the University of Hawaii Sea Grant College Program.

### About the Authors

Arlo W. Fast is an associate researcher with the Hawaii Institute of Marine Biology, University of Hawaii, P. O. Box 1346, Kaneohe, HI 96744. Y. C. Shang is a professor at the Department of Agricultural and Resource Economics, University of Hawaii, Honolulu, HI 96822. I. Chiu Liao is the director general at Taiwan Fisheries Research Institute, 199 Hou-Ih Road, Keelung 20220, Taiwan, Republic of China. Gary L. Rogers is an aquaculture engineer at Aeration Industries, Inc., 4100 Peavey Rd., Chaska, MN 55318.

---

The views expressed in this report do not necessarily reflect those of the University of Hawaii, and the University of Hawaii Sea Grant College Program. Any errors are the sole responsibility of the author. Any commercial product or tradename mentioned herein is not to be construed as an endorsement.

---

The National Sea Grant College Program is a network of institutions working together to promote the wise use, development, and conservation of the nation's coastal, marine, and Great Lake resources. Provisions of the National Sea Grant College and Program Act of 1966 called for the creation of Sea Grant Colleges, and in October 1972, the University of Hawaii was designated one of the first five Sea Grant Colleges in the nation. Locally, Sea Grant is a unique partnership of university, government, and industry focusing on marine research, education, and advisory/extension service.

---

## ABSTRACT

Intensive shrimp culture farms in Taiwan are typically small (3.9 ha), family operated, and profitable. They are also energy intensive, primarily for artificial aeration and water exchange. Shrimp stocking densities average 34 24-day-old postlarvae (PL 24) per m<sup>2</sup>, with 75% survival, 31.5-g harvest size, two crops per year, and average yields of more than 11,000 kg/ha/year. Average feed conversion is 1.7, with a feed price of \$0.88/kg. Seed and feed costs account for 64% of operating costs. Profits on well-run farms with concrete walls should exceed \$16,000/ha/year. Simulated transfer of such farms to Hawaii results in profit losses of -\$11,891/ha/year for earthen ponds and -\$31,900/ha/year for concrete-walled ponds. High labor and energy costs in the United States, compared with Taiwan, account for most of the loss in the United States. A modified Taiwan technology, which is appropriate to the United States and reduces labor and energy costs, might make U.S.-grown shrimp competitive on the world market. Reduced labor and energy consumption could be achieved through improved farm and equipment design; improved water quality management based on pond dynamics principles and objective water exchange criteria; and the application of microcomputers to pond monitoring and management. Additional profits will occur if seed and feed costs can be reduced.

## ACKNOWLEDGMENTS

We wish to thank the staff of the Tungking Marine Laboratory, especially Ziao Liao, Mr. Lin, Dr. Lei Chi-Hsiang, Cheng Jim-Sum, and Lian Hai-Tang, for assistance in arranging and conducting interviews with the farmers. The translation assistance of Peng Dah-Ding and the help provided by Dr. Mark Barnes, both of the Chinese Cultural University in Taipei, were indispensable and greatly appreciated. Peter Chiang and Lin Young-Sen (Sunny) of Hanagua Feed Corporation very graciously provided information and assistance. Lastly, we are especially grateful to the farmers who took the time and had the patience to endure a trying experience of explaining their aquaculture practices to a nosy American.

## TABLE OF CONTENTS

INTRODUCTION .....	1
OBJECTIVES .....	6
METHODS .....	6
RESULTS AND DESCRIPTION OF TAIWAN SHRIMP FARMS .....	8
Land Costs .....	10
Water Depth .....	10
Pond Construction, Construction Costs, and Bottom Types .....	11
Water Supply .....	14
Salinity .....	17
Water Pumping Schedule .....	18
Aeration .....	18
Monitoring .....	21
Bottom Maintenance .....	22
Chemical Use .....	22
Stocking Size, Density, and Seed Source .....	23
Growing Season and Crops per Year .....	24
Harvest Size and Price .....	24
Crop Yields .....	25
Feed and Feed Conversions .....	25
Harvests .....	26
Problems .....	27
Labor .....	37
ECONOMIC ANALYSIS .....	37
Construction Costs .....	37
Operating Costs .....	37
Summary of Analysis .....	40
DISCUSSIONS AND CONCLUSIONS .....	41
REFERENCES .....	45
APPENDIXES .....	49
Appendix A. Summary of Taiwan Farm Survey Data Sheets .....	51
Appendix B. Description of Reinforced Concrete Pond Walls in Taiwan .....	63
Appendix C. Operational Schedule and Costs for Aeration and Water Pumping in Taiwan .....	87
Appendix D. Pond Layout and Construction Estimates in Hawaii .....	91

## LIST OF FIGURES

Figure		
1	Tiger prawn ( <i>Penaeus monodon</i> ) at harvest .....	4
2	Map of Taiwan showing location of farms by stocking density .....	7
3	Earthen-walled ponds at farm 2. An air supply pipe is seen on top of the dike .....	12
4	Earthen-walled ponds at farm 2. Concrete steps lead into the pond .....	13
5	Earthen ponds at farm 5 .....	14
6	Seawater wells at farm 1 .....	15
7	Seawater supply pipes leading from the wells near the ocean to many farms inland .....	16
8	Seawater supply wells on the beach near farm 6 .....	17
9	A 1-hp paddlewheel aerator .....	19
10	A 1-hp paddlewheel aerator in operation .....	20
11	Concrete-walled ponds at farm 2 .....	23
12	Feed net used to measure feed consumption rate of prawns .....	26
13	Harvester towing an electric harvest net .....	28
14	Harvester pulling electric harvest net between a 2-hp paddlewheel aerator and the shore .....	29
15	Four harvesters pulling their electric harvest nets around a pond during harvest .....	30
16	Electric harvest net propped up on a metal support pipe near the weighing station .....	31
17	A harvest basket is lifted from the pond after shrimp are transferred into the basket from the electric harvest net .....	32
18	Shrimp being placed from harvest basket into sorting container .....	33

19	<i>Penaeus monodon</i> being sorted to remove debris, damaged shrimp, and diseased shrimp before weighing .....	34
20	Shrimp in harvest basket being weighed after being sorted .....	35
21	Shrimp are loaded into plastic containers and iced for shipment to the processing plant after weighing .....	36
22	Pie charts of costs as percentages of total production costs for Taiwan concrete ponds and simulated concrete and earthen ponds in Hawaii .....	43

### LIST OF TABLES

Table		
1	Pond Production of Marine Shrimp in Taiwan and in Ecuador Between 1968 and 1985 .....	2
2	Characteristics of Marine Shrimp Culture at Three Levels of Intensity .....	3
3	Partial Summary of Data From 11 Taiwan Marine Shrimp Farms (September 1985) .....	9
4	Estimated Initial Capital Investment for a 4-Ha (Water Surface Area) Earthen and Concrete Pond Farm in Hawaii .....	38
5	Estimated Annual Operating Cost Per Ha Pond on a 4-Ha (Water Surface Area) Farm .....	39



## INTRODUCTION

The United States imports well over \$1 billion worth of marine shrimp products annually, more than any other nation, despite the fact that the United States is the world's fifth largest producer of marine shrimp. The net importation into the United States is likely to continue for the foreseeable future because production of shrimp in the United States is not likely to meet demand (Lawrence, Johns, and Griffin 1984). Shrimp produced in the United States come primarily from trawler fleets in the Gulf of Mexico. This fishery for shrimp is at or near its maximum sustainable yield, and production of shrimp from the Gulf of Mexico is not likely to increase.

Hawaii, like the United States as a whole, is a net importer of marine shrimp. Hawaii imports about 3 million pounds annually, which is worth about \$15 million (Macaulay, Samples, and Shang 1983; Wiles 1984). Although there is an emerging shrimp aquaculture industry in Hawaii, shrimp currently grown in Hawaii are not cost competitive with imported shrimp. Locally grown shrimp primarily satisfy a pocket or specialty market for fresh, whole-bodied shrimp.

On a global basis, the world's marine shrimp fisheries have stabilized at about 1.7 million metric tons (Asian Development Bank 1983). Like the situation in the Gulf of Mexico, the world's catch of shrimp from the wild is thought to be at or near maximum sustainable yield. There are not likely to be any major increases in the number of shrimp captured from the wild.

In 1985, wild-caught shrimp, on a worldwide basis, comprised more than 90% of all shrimp produced, with less than 10% of the shrimp being cultured in ponds (Lawrence 1985). This situation, however, is changing rapidly. Aquacultural production of marine shrimp is increasing at a phenomenal rate, especially in South and Central America, mainland China, and Southeast Asia (Lawrence 1985; New and Rabanal 1985). If this increase continues, it is most likely that pond-cultured shrimp not only will accommodate all increased consumption of shrimp but also will start to decrease prices through oversupply and thereby displace wild-caught shrimp production in the process.

Shrimp pond production data from Ecuador and Taiwan illustrate the increases in pond-cultured shrimp production which have begun worldwide. Pond-produced shrimp in Taiwan, primarily tiger prawn, increased from 61 to 45,000 metric tons between 1968 and 1986, with the greatest increase occurring after 1980 (Table 1). Likewise, in Ecuador, pond-cultured shrimp production increased from 1,170 to 30,205 metric tons between 1976 and 1985. Taiwan and Ecuador together accounted for about 38% of the world's cultured shrimp production during 1984, when estimated world production of cultured shrimp was 134,000 metric tons (Lawrence 1985). These shrimp production increases are occurring in many tropical countries, with Taiwan and Ecuador as two of the leading countries due to their development of a critical mass of production and support components for their shrimp culture industries.

The motivation for shrimp culture is driven by economic factors, but it is made possible by technological breakthroughs in culture techniques. One of the first major breakthroughs was the maturation and spawning of a marine shrimp in captivity by Hudinaga (1942). There are about a dozen species of shrimp which are or can be matured and reared in captivity on a large scale. Of these *Penaus monodon*, *P. vannamei*, *P. indicus*, *P. merguensis*, *P. orientalis*, and *P. stylirostris* are by

TABLE 1. POND PRODUCTION OF MARINE SHRIMP IN TAIWAN AND IN ECUADOR BETWEEN 1968 AND 1985

Year	Taiwan Production (metric tons)	Ecuador Production (metric tons)
1968	61	N/A
1969	69	N/A
1970	73	N/A
1971	76	N/A
1972	112	N/A
1973	119	N/A
1974	140	N/A
1975	150	N/A
1976	270	1,170
1977	1,100	1,350
1978	1,556	4,215
1979	4,123	4,698
1980	5,000	9,180
1981	6,000	12,100
1982	8,000	21,500
1983	15,000	35,600
1984	18,000	33,600
1985	30,000	30,205
1986	45,000	N/A

Source: Data from Chiang and Liao (1985), Liao (1987), and Anonymous (1987)

far the most important cultured species. Hudinaga's breakthrough was followed by improvements in shrimp seed production, as well as production of seed from many species of shrimp (Primavera 1985). After seed production technologies developed, there were breakthroughs in feeds and other aspects of shrimp culture. These advances, which continue, are often country or region specific. This has led to the emergence of a variety of shrimp growout approaches. Each approach has its limitations and advantages.

Most cultured shrimp are still produced in relatively primitive growout systems. These systems, known as extensive growout systems, are characterized by large ponds with very little materials, energy, or cost inputs (Table 2). Extensive growout is also characterized by low yields of shrimp per unit area. In places where land, labor, and shrimp seed are abundant and inexpensive, this type of shrimp aquaculture may be quite profitable (Hirasawa 1985). Most growout systems in Ecuador and Southeast Asia are extensive.

In places where land and labor are expensive, intensive culture systems have evolved. These systems are characterized by small pond size, high feed and energy inputs, continuous management attention, and high yield. These intensive growout systems have primarily evolved in Taiwan and Japan (Hirasawa 1985).

TABLE 2. CHARACTERISTICS OF MARINE SHRIMP CULTURE AT THREE LEVELS OF INTENSITY

Characteristic	Level of Intensity		
	Extensive	Semi-intensive	Intensive
Production Level (kg/ha/yr)	100 to 500	500 to 4,000	5,000 to 15,000
Stocking Rate (stock no./m <sup>2</sup> /crop)	0.1 to 1.0	1 to 10	20 or more
Feed	Natural	Natural + Supplement	Formulated
Water Exchange (%/day)	For evaporation and seepage replacement (often by tidal exchange)	1% to 15%	10% to 100%
Pond Size (ha)	>5	1 to 2	1 or less
Supplemental Aeration	None	Some for emergencies	Continual mechanical and flushing

Source: Modified from Apud, Primavera, and Torres 1983

In Japan, intensive shrimp culture using the Shigueno system has concentrated on production of *Penaeus japonicus* (Shigueno 1985). This is a cool-water penaeid which demands a very high price in Japan. It also requires special culture techniques, such as a clean sand bottom and high-energy inputs for water circulation and aeration. Using this system, standing crops of 3.5 kg/m<sup>2</sup> and yields of 35,000 kg/crop are possible (Kurata, Yatsuyanagi, and Shigueno 1980). These high-energy inputs, plus the relatively slow growth of this species, make its culture marginally profitable at times even in Japan. The profitability of the Shigueno system is closely linked to the cost of energy.

More recently, an ultraintensive shrimp culture system was developed in the United States initially through research efforts of the Coca-Cola Company and the University of Arizona. This system, relies on covered raceways, very high water exchange rates, and pure oxygen injection. Shrimp densities of 4 kg/m<sup>2</sup> or more are common, with occasional live weight standing crops of 70,000 kg/ha (Liao 1985; Colvin 1985; Salser, Mahler, Lightner, Ure, Danald, Brand, Stamp, Moore, and Colvin 1978). The economic feasibility of this system is still under evaluation.

In Taiwan, intensive shrimp culture has concentrated almost entirely on production of *Penaeus monodon*. *P. monodon* is known as the grass prawn in Taiwan, while elsewhere it is commonly known as the giant tiger prawn, sugpo, or black tiger prawn (Figure 1). It will be referred to as the tiger prawn in this report.

Tiger prawns in Taiwan are usually cultured in earthen ponds with either concrete or earthen dikes. Production levels in these ponds can be very high. The countrywide average for Taiwan intensive culture systems during 1985 was about 5,000 kg/ha/year, with some farms exceeding 20,000 kg/ha/year (Chiang and Liao 1985). From all accounts, these tiger prawn farms in Taiwan are profitable.



Figure 1. Tiger prawn (*Penaeus monodon*) at harvest. This specimen weighed about 32 g.

Although the Taiwan intensive culture system seems to work well in Taiwan, there have been few documented cases of this technology being used elsewhere with as high a yield or as much profit. The most notable exception is the farm operated by the San Miguel Corporation on Negros Island in the Philippines. At the time it was built, this model farm demonstrated a direct transfer of the best available Taiwan intensive culture system technology for tiger prawns. Production from this farm was projected at 10,000 to 13,000 kg/ha/year (9,200 to 12,000 lb/acre/year), with best case estimates of 24,250 kg/ha/year (22,250 lb/acre/year) (Veloso 1984; Liu and Mancebo 1983). The average production yielded a net profit of \$15,802/acre/year with production costs and selling prices of \$1.65/lb and \$3.27/lb for whole shrimp respectively.

The tiger prawn culture industry in Taiwan is of considerable interest to those associated with the development of appropriate shrimp aquaculture technology for the United States. There is concern that the United States is not producing marine shrimp on a competitive basis with foreign-produced shrimp and that the United States is not developing appropriate shrimp culture technology. Appropriate shrimp culture technology for the United States is defined as technology which will allow the United States to produce shrimp, with all the specific constraints for commercial shrimp culture in the United States, on a cost-competitive basis. This is not happening now nor is there a clear trend that it will happen soon, despite the optimism and persistence of the pioneers in the U.S. shrimp culture industry.

The reason Taiwan shrimp aquaculture technology has caught our interest is that it seems to be relevant to some of the more important economic constraints in the United States. Land costs are high in Taiwan, as they are in the United States. Production systems that maximize production per unit land area should be appropriate to both areas. Seed, feed, and other aspects of shrimp production in Taiwan are relatively sophisticated; all of which the United States should be able to master. Although labor costs and other aspects of shrimp culture in Taiwan differ substantially from conditions in the United States, there are enough relevant aspects to evaluate the possible transfer of this technology to the United States, in particular to Hawaii.

Although the basic elements of the Taiwan intensive shrimp aquaculture system are known, there is insufficient information in the literature to determine the potential profitability of these operations in Hawaii. Although shrimp farmers in Taiwan apparently do quite well, it is not known if they would do as well if their farms and technology were transferred to Hawaii. Economic and social conditions are sufficiently different to make the economic viability of these operations in Hawaii questionable. In order to answer the question of profitability in Hawaii, these farms must first be described in more detail, then an economic analysis of these farms needs to be conducted. Next a simulated transfer of these farms to Hawaii must be done, and the economic analysis repeated. Lastly, the economics of shrimp culture in Taiwan and Hawaii need to be compared, and improvements to U.S. technology must be determined in order to lower production costs in the United States.

This exercise, at least in part, is a process for helping direct future research efforts. By focusing attention on the few critical items which are affecting shrimp culture profitability in the United States, it is hoped progress toward the U.S. goal of self-sufficiency will be accelerated. Indeed, it is necessary to know whether self-sufficiency is attainable at all.

## OBJECTIVES

The purpose of this study is to determine if the Taiwan intensive shrimp culture system can be transferred to Hawaii, retaining profitability in Hawaii comparable to that in Taiwan. Specific goals and objectives include the following:

1. To document the Taiwan intensive culture system for marine shrimp, including: pond construction; pond layout; pond management techniques; farm sizes; labor; shrimp species used; shrimp stocking densities; feeds and feeding practices; water exchange rates; water salinities; aeration techniques and equipment; shrimp growth rates; shrimp production rates; growing seasons; water temperature effects; and other factors of importance to the performance of this culture system.
2. To evaluate the economic viability of this system of shrimp culture in Taiwan.
3. To simulate a shrimp growout facility in Hawaii, based on direct transfer of the Taiwan method, and evaluate the economic viability of the simulations.
4. To compare the economics of shrimp culture in Taiwan and Hawaii to see which items account for the principal costs and which items most affect profitability in each place. These comparisons will identify problem areas that may exist in U.S. shrimp culture and give direction to future research and development efforts.
5. To publish and extend this study's findings so that they are available to the U.S. shrimp aquaculture industry and shrimp aquaculture researchers in the United States.

## METHODS

Between September 16 and 21, 1985, an in-depth survey of 11 intensive shrimp farms in the vicinity of Tungkang and Kaohsiung was conducted. This region of southern Taiwan has the greatest concentration of intensive shrimp growout facilities (Figure 2). The farms were selected to represent some of the more efficient and profitable operations because this study was mainly interested in information on well-run, profitable farms.

A prepared survey form was to be used to gather information from the farmer. However, after the first few interviews, it became clear that all of the information originally hoped for could not be obtained, but enough of the most important information was gathered. The form served as a useful guide but was not used in its entirety.

Most of the farmers either did not speak English at all, or not well enough to answer all of the questions. For that reason, either Peng Dah-Ding of the Chinese Cultural University or an employee from the Tungkang Marine Laboratory acted as interpreter at each interview.

The interviews ranged from 1 to 4 hours each. Each interview was preceded by a tour of the farm, in which ponds, wells, pumps, aerators, feed storage facilities, etc., were inspected.

Questions were asked regarding production estimates so that to some extent the values given could be cross-checked. All estimates were not verified in this way, but based on this approach

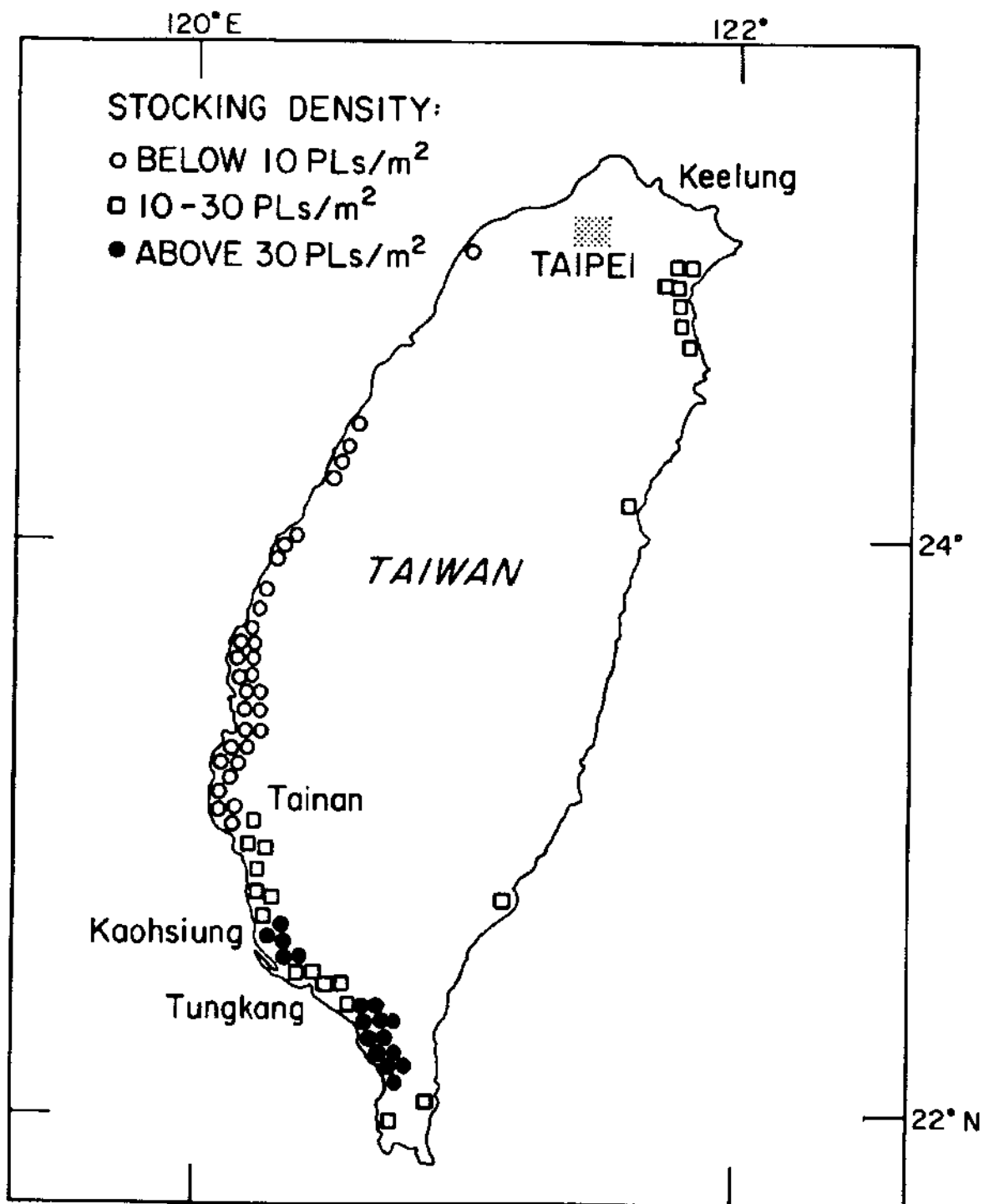

Figure 2. Map of Taiwan showing location of farms by stocking density. Data from Chiang and Liao (1985).

information with major discrepancies was disregarded. This was a somewhat subjective method, but it is believed the resulting production values are more accurate. Some information, such as the amount of time that the water pumps were operated, was almost impossible to gather because the farmers did not seem to pay much attention to this. When asked, invariably the response was "as needed." In these cases, the literature was used to obtain the information. In other cases, especially concerning individual profits, the farmers were reluctant to disclose such information. In these cases, either an estimate based on the information they did provide, on literature values, or on commonly known market values was used.

Most of the assumptions made for the economic analysis are listed in the "Economic Analysis" section. In addition, for the Hawaii projections, it was assumed that the shrimp industry has grown to a size where comparable levels of competition and services are available. Specifically, it was assumed that the growth of the industry in Hawaii would result in delivery of quality feeds at Taiwan prices to the farmer; a processing and marketing component which would purchase the crop at pond-side at world pond-side prices for processing into frozen block; a hatchery/nursery component which would produce 20-day-old postlarval shrimp seed at Taiwan prices; and supply houses which would provide various necessary materials to the farmer. In Taiwan, few farmers had electronic water quality monitoring equipment or vehicles. The same situation was assumed for the Hawaii economic analysis. An average number of 2.0 crops in Taiwan and 2.5 in Hawaii were assumed. This assumption reflects the finding of the survey of Taiwan shrimp farms and experience in Hawaii. Pond water temperatures are higher in Hawaii and thus allow 12-month growout, although growth is slower during the winter than during the warmer months.

The currency exchange rate during the survey was \$40 (New Taiwanese (N.T.)) to \$1.00 (U.S.). This same exchange rate was used for the economic analysis, although more recently (1987), the exchange rate has fallen sharply to \$30 (N.T.)/\$1.00 or less. The effect of this revaluation on shrimp culture economics in Taiwan is complicated and beyond the scope of this analysis. Perhaps a period of currency stabilization will be necessary before the full impact of a new exchange rate can be measured. Unless otherwise noted, all dollar amounts used in this report are in U.S. dollars.

A common unit of weight measure in Taiwan is the Taiwan kilogram, which is equivalent to 0.6 standard kilograms. The standard kg (1,000 g) was used throughout this report. Tons in this report are metric tons, equivalent to 1,000 kg.

## RESULTS AND DESCRIPTION OF TAIWAN SHRIMP FARMS

The 11 intensive culture *Penaeus monodon* farms that were visited appeared to be representative of the more successful farms of this type. The farms were typically small, family-run operations. The number of ponds per farm ranged from two to 12, with an average of seven (Table 3). The pond area per farm ranged from 0.4 to 14 ha, with an average pond area per farm of 3.9 ha (9.4 acres). In many cases, the farms had previously been used to grow milkfish (*Chanos chanos*) or eels but had been converted to tiger prawn culture within the past 4 to 6 years due to greater profit potentials.



TABLE 3. PARTIAL SUMMARY OF DATA FROM 11 TAIWAN MARINE SHRIMP FARMS (SEPTEMBER 1985)

Parameter	Farm											Average
	1*	2	3*	4	5	6*	7*	8	9*	10*	11	
1. Number of Growout Ponds	11	5	3	2	9	12	6	11	6	9	3	7
2. Total Pond Area (ha)	1.1	1.5	0.8	0.4	7.0	3.5	3.5	4.5	5.4	14	1.3	3.9
3. Maximum Water Depth (m)	2.0	2.0	2.0	1.5	1.5	1.2	N/A	1.5	2.0	N/A	2.0	1.7
4. Bottom Type†	SA	SA	MU	SA	MU	MU/C	MU	MU	MU	MU	MU	—
5. Bank Type†	CO	CO	SO	CO	SO	CO	CO	CO	CO	SO	CO	—
6. Freshwater Supply†	WE	NO	NO	WE	WE	WE	WE	WE	WE	WE	WE	—
7. Seawater Supply†	WE	WE	WE	WE	WE	WE	CA	WE	CA	WE	WE	—
8. Total Pump (hp)	20	25	7	10.5	20	60	9	38	12	50	24	25
9. Total Aerator (hp)	22	10	6	6	14	35	48	53	32	59	18	28
10. Aerator (hp/ha)	20.0	6.7	7.5	15	2	10	13.7	11.8	5.9	4.2	13.8	10.0
11. Growing Season (mo) for Shrimp	12	8	8	8	12	8	8	12	8.5	9	9	9.3
12. Stocking Density (PL/m <sup>2</sup> )	35	60	20	42	^	20	40	^	20	25	N/A	34
13. Age Stocked (days)	20-30	12-15	30-35	5	45	25	20-25	20-25	20	30	N/A	24
14. Size at Harvest (g)	30	29	29	33	32	36	32	30	34	30	N/A	31.5
15. Total Yield/ha/year (metric tons)	12	20.6	4.8	20	^	13.7	7.6	10	9	6	N/A	11.5
16. Fec/ha/year (metric tons)	22	N/A	7.1	^	^	25.9	N/A	20	2.6	10.5	N/A	—
17. Feed Conversion	1.8	N/A	1.5	^	^	1.9	N/A	2.0	1.4	1.75	N/A	1.7

\*Production data probably most reliable

†SA=sand, MU=mud, C=clay, CO=concrete, SO=soil, WE=well, CA=canal, NO=none

^Discrepancy in data

The data shown in Table 3 is from the farm summary forms in Appendix A. These forms are a summary of some of the information gathered from the farmers.

### Land Costs

Land costs are generally high in Taiwan but vary greatly depending on location and conditions. For shrimp farming, nearness to the ocean; availability of both freshwater and seawater; access and utilities; and the subsidence rate of the land have major influence on land price. Land subsidence is a major concern and is a recent development caused by overdraft of the groundwater resources by shrimp farms. These farms pump large volumes of fresh-, brackish-, and seawater from the ground at a rate greater than the recharge.

During the survey, farmers indicated raw land costs for farm sites may range from \$50,000 to \$200,000/ha. Probably the most likely cost for land in an area which was not sinking was between \$100,000 and \$120,000/ha. By contrast, farm 6, which had about 4 ha of land (3.5 ha of ponds) but was sinking at a rate of 20 cm/year, had recently sold for \$342,000 including improvements.

There are efforts underway to develop other more salt-tolerant shrimp species for intensive culture to reduce overdraft of groundwater.

### Water Depth

Average water depth was 1.7 m (5.6 ft) (Table 3) and ranged from 1.2 to 2.0 m. Many of the farmers indicated they operated their ponds at shallower depths (e.g., 1 m) in the past, but they had to increase pond depth as they intensified their production. None of the farmers could explain the underlying pond dynamics principle behind the need for greater pond depth during intensification, but all were certain of the need for greater depth. When asked why a greater depth was necessary, the answer was usually: "better production" or "by experience."

Several farmers indicated they kept water depth at about 1 m when postlarvae were stocked but gradually increased the depth during growout. Again, there was no principle given, other than this gave better results.

It must be concluded that the experience of the Taiwanese prawn farmers is valid and that deeper ponds do give more reliable production and greater yields than do shallow ponds, even though the underlying reasons for these effects are not known. It remains to be seen what pond dynamics processes are involved and whether even deeper ponds (e.g., 5 m) would give even better results.

Deep ponds are considerably more costly to construct than shallow ponds and almost certainly more costly to maintain and operate as well. Deeper ponds have more water to aerate and exchange at a greater energy cost.

## Pond Construction, Construction Costs, and Bottom Types

Eight of the 11 ponds had concrete banks or sidewalls, while three had soil banks (Table 3). Descriptions of some of the concrete walls are given in Appendix B.

The main reason for the concrete dikes is to conserve land area, because land is expensive and land parcels are often small. With a concrete wall, virtually the entire plot of land can be used for pond production. A soil bank, with slopes of about 1:2 or 1:3 and a berm width of about 3 to 5 meters, would use a large amount of the land area. When small, deep ponds are involved, this would not leave much bottom area for growout. With small plots, small ponds, and soil dikes, perhaps half of the potentially usable land area would be taken up by berms and banks, while with concrete dikes the amount taken up by berms and dikes might be about 5%.

Earthen construction and pond maintenance costs of earthen ponds are quite low in Taiwan. Farmer 3 indicated it only cost \$1,500 to excavate three ponds with a total pond area of 0.8 ha (Figures 3 and 4; Appendix A). This is equivalent to \$1,875/ha or \$781/acre, with pond sizes of about 0.25 ha (0.6 acres). Yearly maintenance on the dikes and bottoms of a 0.8 ha pond was only \$150. Farmer 5, who used large earthen ponds, indicated his excavation costs were only \$1,250/ha (Figure 5; Appendix A).

By comparison, construction costs for concrete-walled ponds are quite high. Most of the farmers who used this pond construction indicated if they had it to do over again, they would find a location where land was less expensive and build their ponds larger, using soil dikes instead of concrete. Farmer 2 estimated it would cost him \$125,000 to build 1.5 ha of concrete-walled ponds in 1985 (Appendix A). This amounts to \$83,333/ha for 0.33 ha-sized ponds. It is estimated more than \$139,650/ha is required to build a 0.25-ha sized walled pond in the United States, with concrete wall construction costs of \$255/m (see "Economic Analysis" section; Appendix B). Wall construction costs in the United States, based on the Taiwan wall designs, ranged from \$179 to \$412/m. Comparable cost estimates for these same walls as built in Taiwan are not available.

Most of the ponds had natural soil bottoms, although several of the farmers imported clay soil, and/or sand to layer the natural soil. Some farmers felt a sand layer was desirable, although these farms did not seem to perform much better than the ones with natural soil. The clay soil may have been imported to control seepage rather than to provide an improved substrate for the prawns.

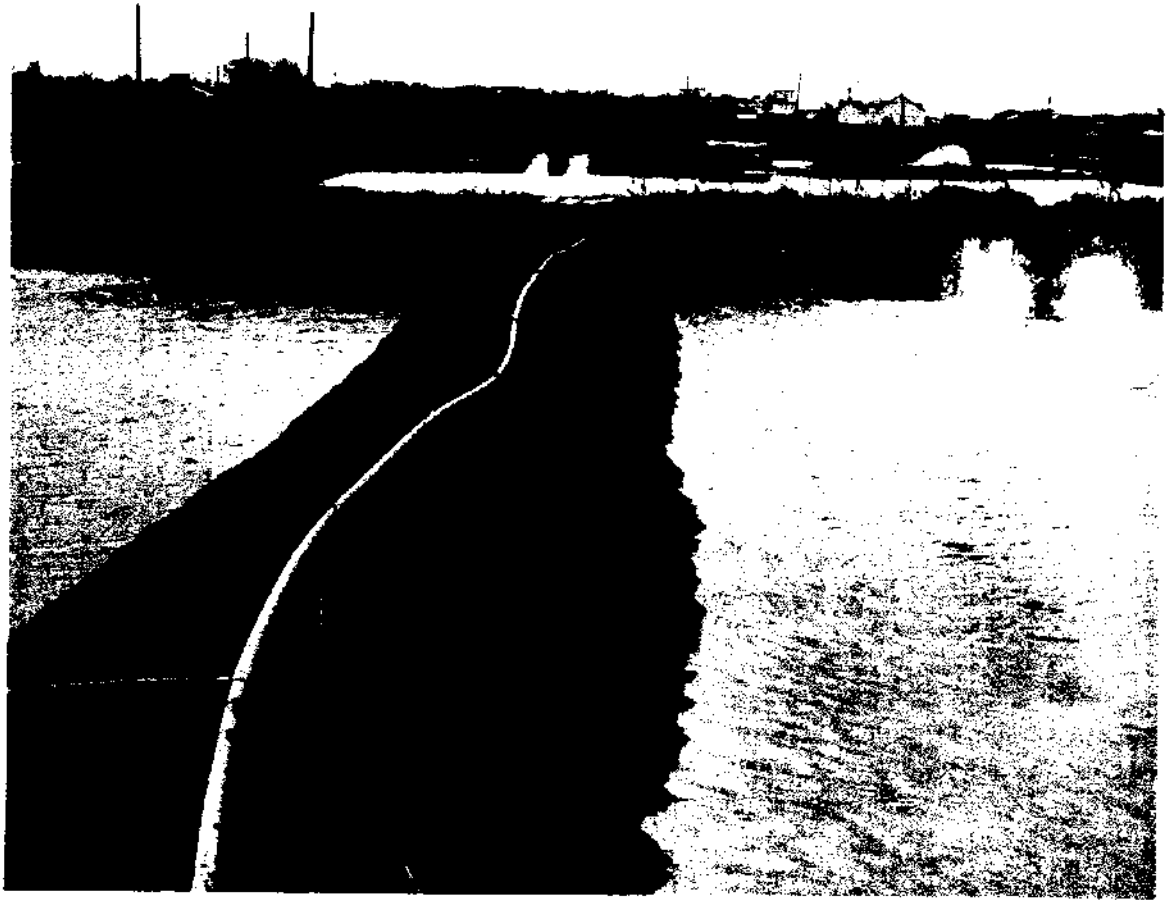

*Figure 3. Earthen-walled ponds at farm 2. An air supply pipe is seen on top of the dike.*

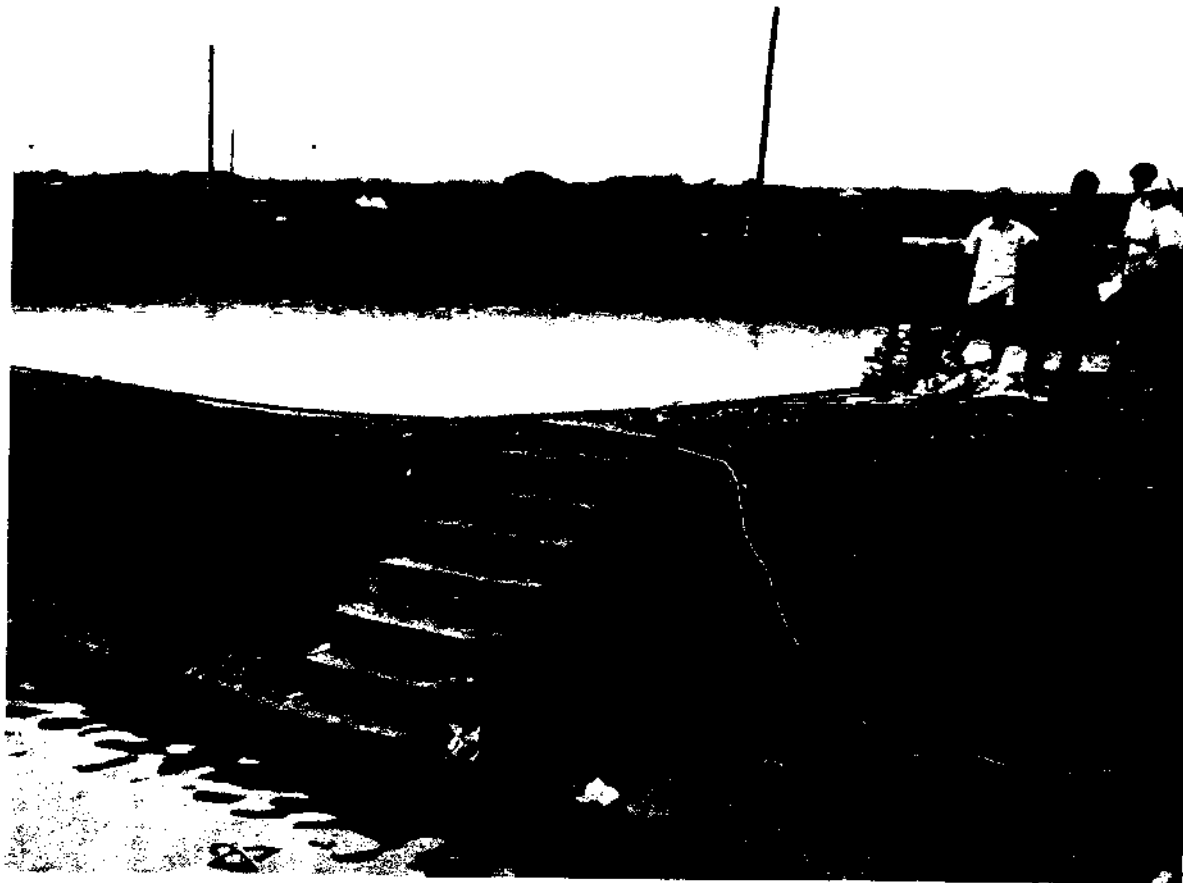

*Figure 4. Earthen-walled ponds at farm 2. Concrete steps lead into the pond. Note erosion of banks.*

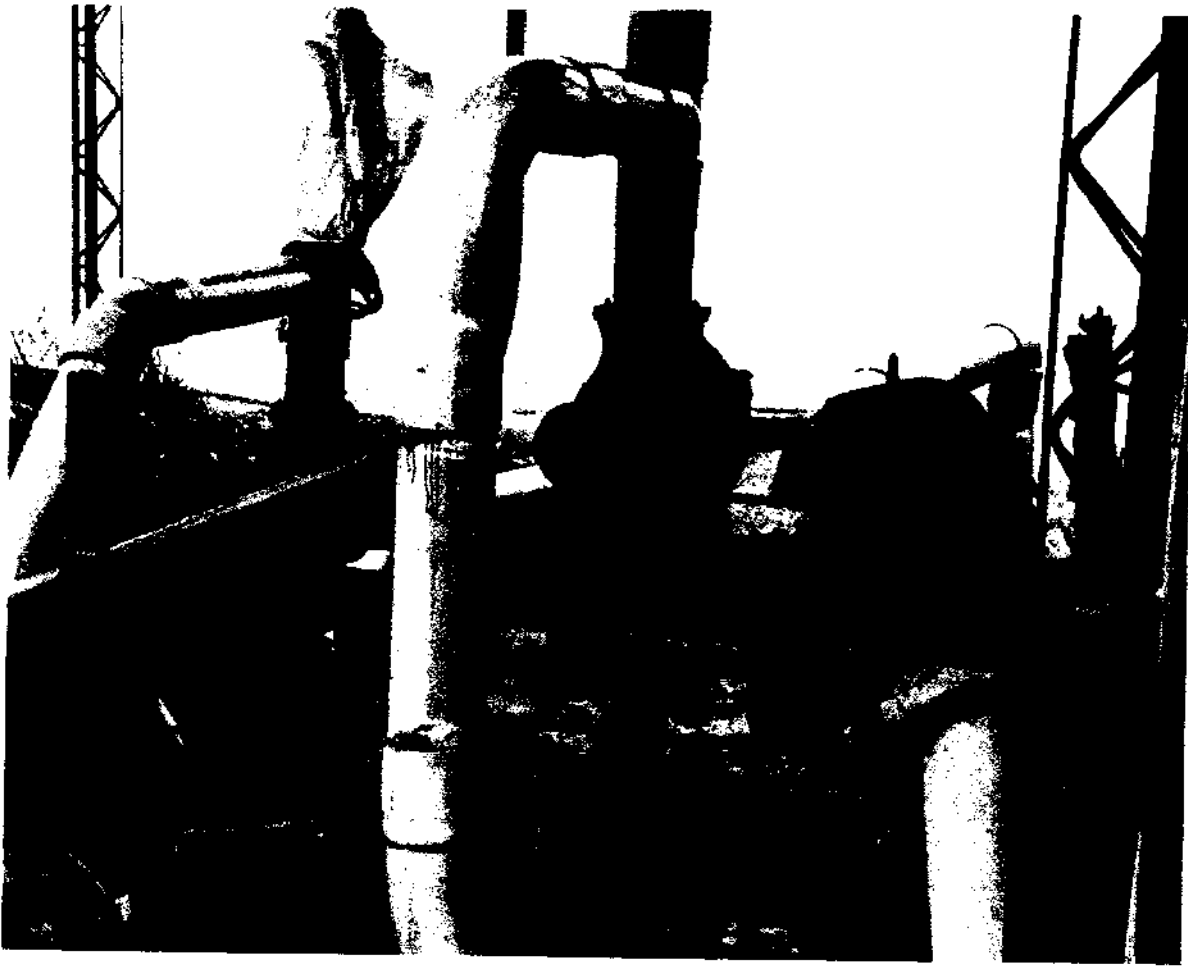

*Figure 5. Earthen ponds at farm 5.*

### **Water Supply**

Most farms had at least two well systems, one freshwater and one saltwater (Figure 6). The farms located within a kilometer or so of the ocean would typically sink a well near the beach or run a pipe out into the ocean with the intake covered with sand/gravel and then pump the seawater to their farms (Figures 7 and 8). Some farms had open pipe intakes in the ocean, but this was the exception. Most farms also had a freshwater well, which was sunk vertically on the property, away from the ocean. The freshwater well depths ranged from 20 to 150 m.

Some of the farms took their water from a canal or river. In some cases, this provided adequate salinity control, while in other cases (e.g., farm 8, Appendix A) it was inadequate. Farmers who used canal or river water would sometimes do so by gravity flow without pumping.

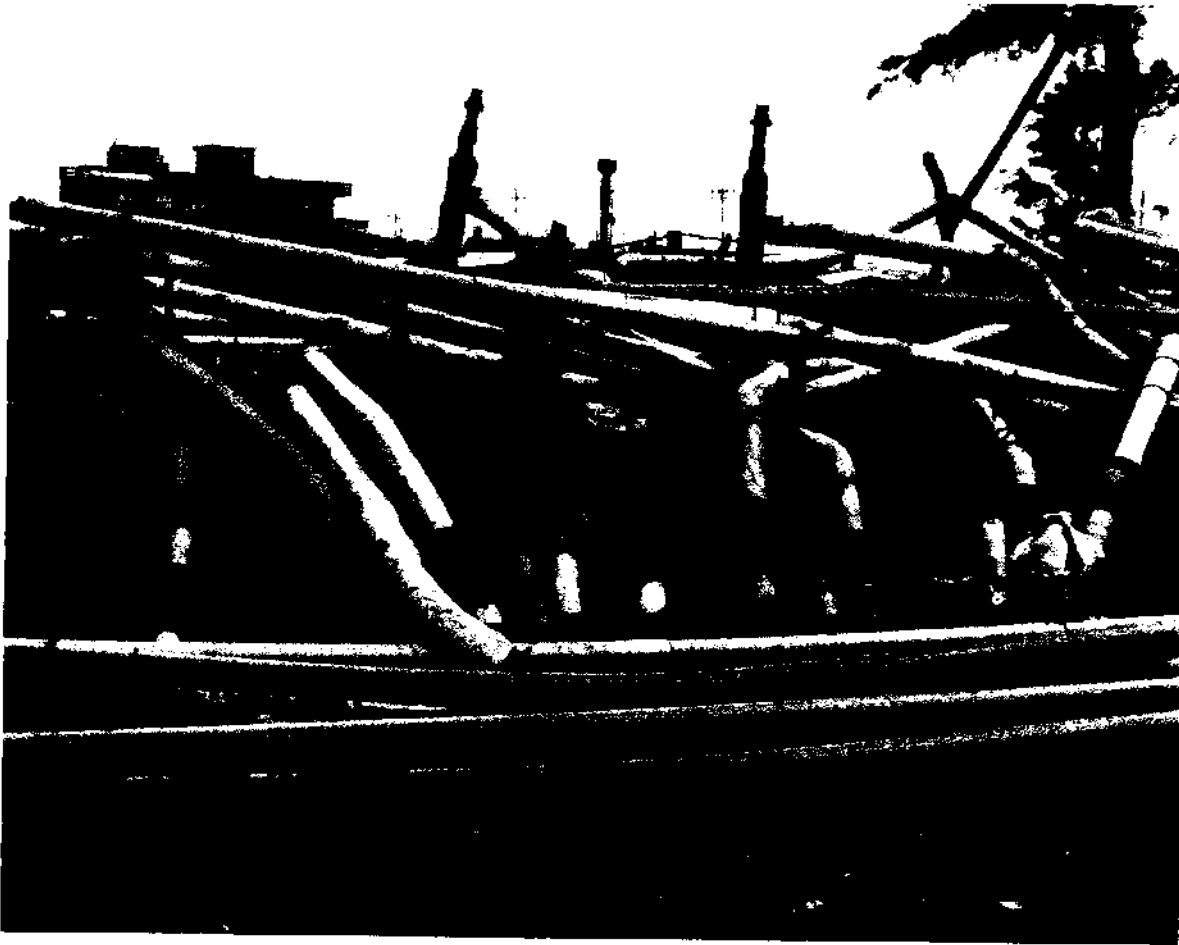

*Figure 6. Seawater wells at farm 1. The intake extends out under the ocean in background.*



*Figure 7. Seawater supply pipes leading from the wells near the ocean to many farms inland. Pipe diameters are typically 11 cm (4 to 5 inches).*





*Figure 8. Seawater supply wells on the beach near farm 6. The pipes angle out under the beach.*

The number and size of wells per farm varied from two wells and 7 horsepower (hp) at farm 3 to 11 wells and 60 hp at farms 10 and 6 respectively (Appendix A, Table 3).

The average water pump hp per farm was 25, with an average ratio of pump hp to pond area of 6.4 hp/ha (2.7 hp/acre).

### **Salinity**

Salinity control is considered very important and is the reason for the development of freshwater and seawater wells. Tiger prawns apparently grow best within a salinity range of 15 to 20 ppt, although their temperature/salinity growth response has not yet been quantified. Farmers adjusted salinity by adjusting the pumping rates from their various wells. They measured salinity in the ponds and from the wells with hydrometers. When multiple wells were involved, each with

different salinities, and weather and pond conditions were considered, balancing pumping from each well could be complicated. This could explain in part the farmers' inability to give specific data on their pumping schedules.

### Water Pumping Schedule

None of the farmers kept records of their pump operations nor did they seem to have any recollection of how often the pumps ran per growout cycle. The usual response to questions about pump operations was: "based on experience."

Farmer 6 indicated he pumped water to control the water pH. He said pH would rise throughout the growout even with pumping, from perhaps 7.8 for the first 45 days of growout to about 8.0 during the last portion of growout. The rising pH was undoubtedly a response of increased algal production as greater amounts of feed were applied.

Most farmers indicated they pumped more water during the last part of growout. They might exchange no water during the first months but much more during the final month.

As a rule of thumb, average water exchange rates of 10% per day per crop are generally accepted as standard practice under Taiwan intensive culture. This has not, however, been well documented nor has the schedule been defined as a function of shrimp size or water quality. Water exchange rates as high as 100%/day have been reported (Hirasawa 1985). Water exchange may be used to remove excess metabolites; to keep algae healthy and producing ample oxygen; and to increase pond temperature during the winter when groundwater temperatures are greater than surface-water temperatures. As yet, the relationship between water exchange and shrimp production potential has not been quantified.

While high water exchange clearly can greatly increase the production capacity of a growout pond, there is a significant cost involved. Pumping cost considerations are discussed in Appendix C.

### Aeration

All farms relied heavily, and almost exclusively, on paddlewheel aerators for aeration of their prawn ponds. (Figures 9 and 10). Most farms used the 1 hp models, although some farmers replaced the 1 hp motor with a 2-hp motor after the 1 hp motor burned out. Motor burnouts were part of routine operation, but they could be accelerated by a partial sinking of the pontoons due to leaks or biofouling. This partial sinking would cause the blades to dip deeper, causing the motor to work harder and burn out faster. Replacing the burned-out motor with a larger motor alleviated this problem. Motor burnout can also be partly avoided by using an amp meter with each aerator, so the current draw can be monitored. Some farmers used 2-hp paddlewheel aerator models, but these represented less than 25% of the aerators in use.

The typical construction of the paddlewheel aerators was: plastic floats (two or three); a motor and gear reduction box mounted on a stainless steel, angle iron (paddle speed is about 100 rpm); two solid stainless steel axles coming out of the gear reduction box and resting on a block of

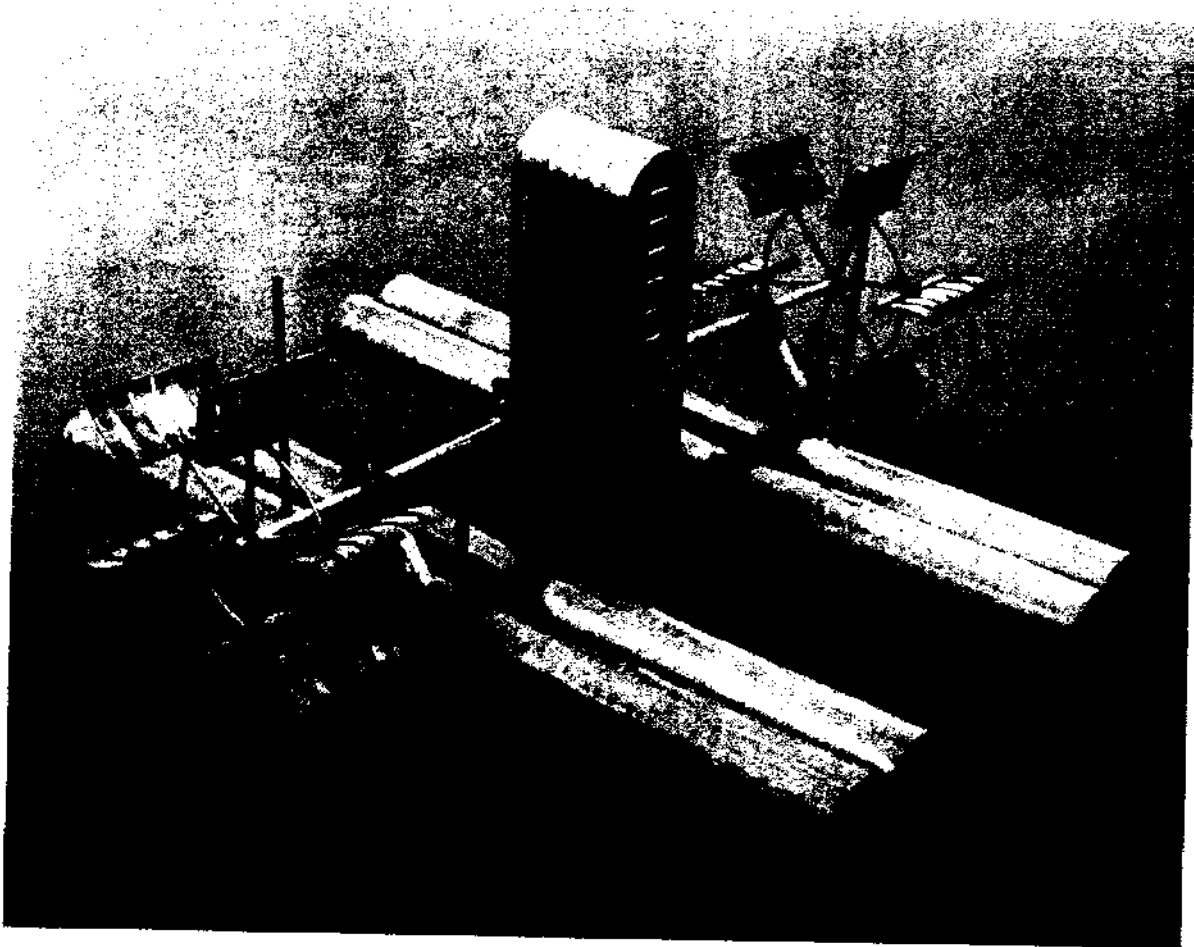

*Figure 9. A 1-hp paddlewheel aerator. The impellers (paddle wheels) are welded into one piece. The floats are plugged PVC pipes. All exposed metal parts are stainless steel.*

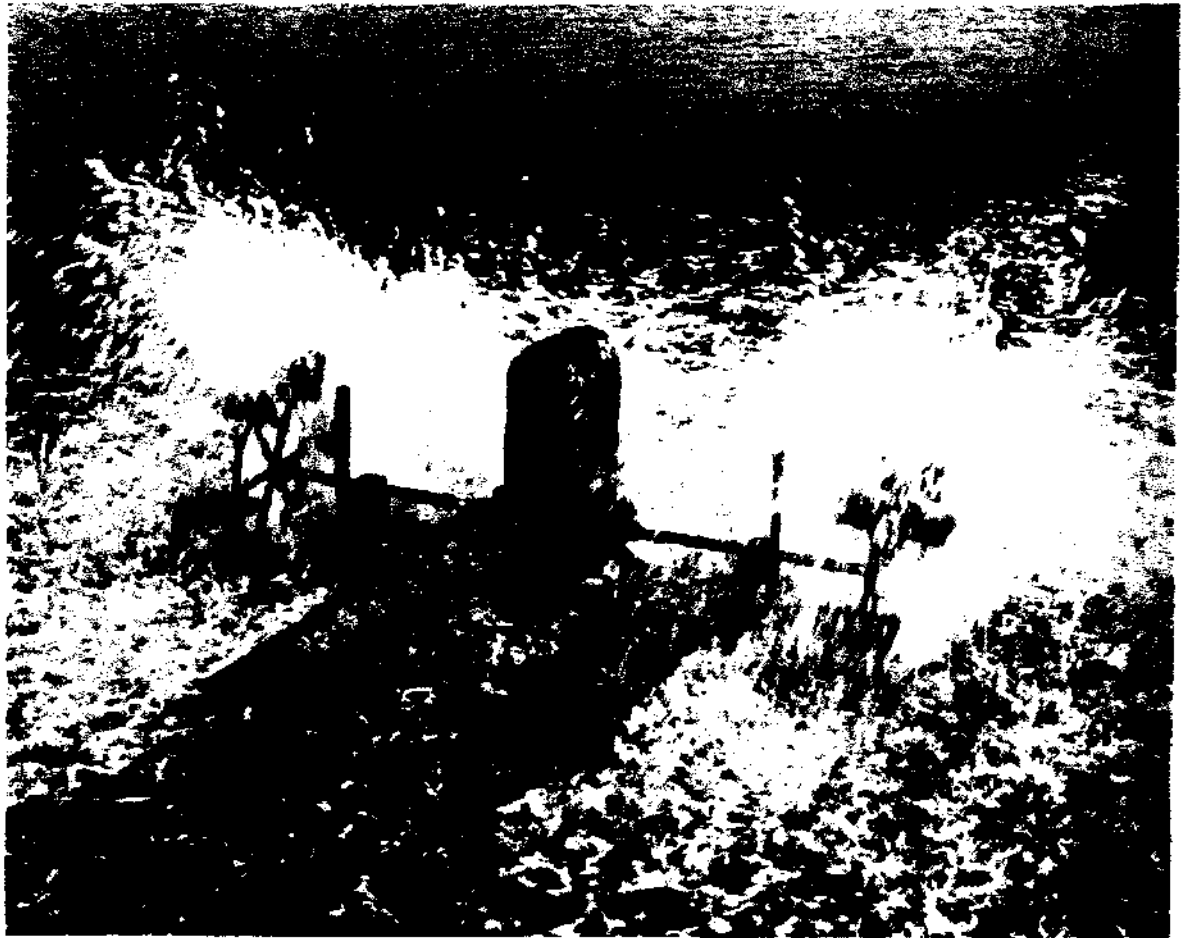

*Figure 10. A 1-hp paddlewheel aerator in operation. All exposed surfaces are covered by a thick layer of algae.*

wood or plastic/bronze bushing at the end of the frame; a rubber universal joint near the gear reduction box on each axle; and a paddle wheel (impeller) on each axle. The paddle wheels were generally one piece of welded stainless steel. Some plastic impellers were seen, but these were inferior and prone to breakage. Plastic impellers have since improved and are now more commonly used. There are many small manufacturers of paddlewheel aerators throughout Taiwan, but most are the same basic design. The cost of a 1 hp model in Taiwan is about \$300.

The total aerator horsepower per farm averaged 28 for the farms surveyed. This amounts to 10.0 hp/ha (4.2 hp/acre).

Almost all farmers use the same aeration schedule. During a 3-month growout, they seldom aerate during the first month unless it is cloudy or the shrimp seem to be in distress. During the second month, the aerator is run every night from about 10:00 p.m. to dawn and when it is cloudy or otherwise needed during the day. During the third month, the aerators are run continuous.

Some farmers said they based their aerator operation on shrimp size (or indirectly on feed input rate). Their schedule was to aerate at night when the shrimp were small (less than 20 g) and continuously when the shrimp were large (greater than 20 g). They would also aerate on cloudy days or “as needed” even when the shrimp were small.

Farmers prefer to use at least two aerators per pond and to position them so that the water currents in the pond are circular. That is, the water flow is highest around the pond bank, with the lowest currents at the center of the pond. This promotes the settling of organic matter in the center of the pond. Ponds with a center drain may remove some of this material more easily, but in any event, the bottom area around the banks tends to remain relatively clear of chemically reduced organic sediments, while the pond center accumulates these sediments. When the pond is drained, a common observation is a black sediment (reduced materials) in the pond center and a brown sediment (oxidized materials) around the periphery.

Shrimp are thought to avoid anaerobic, reduced sediments. Therefore, aerator operation creates not only suitable oxygen concentrations in the pond water but also desirable sediment distribution patterns as well.

If feed settles on the reduced sediments, it might not be as readily found and/or eaten as feed applied on oxidized sediments. Feed which is thrown into the pond from the bank will normally settle near the bank and onto the oxidized sediments.

If organic matter are allowed to settle evenly throughout the pond, most likely the entire bottom would develop a layer of reduced, black sediment. As described above, the aerators can prevent this and maximize the amount of well-oxidized bottom area.

### **Monitoring**

Only two of the 11 farms had dissolved oxygen (DO) meters (Appendix A). Even these two, however, did not rely on the meters to make aeration, water exchange, or other water quality management decisions. Instead, the farmers relied on such things as water color and appearance, shrimp size and biomass, shrimp behavior, and other subjective factors when making pond management decisions.

Farmer 6 (Appendix A) used water pH as a criterion to determine water exchange rate. During the first 45 days, if the pH exceeded 7.8, the farmer would pump water into the pond until the pH dropped below 7.8. After 45 days, the farmer pumped water to maintain a pH of 8.0 or less. During growout, the increased feed inputs accelerated photosynthesis and as a result caused pH increases. This was the only farmer who used this approach.

In addition to the observational inputs to decisionmaking noted above, farmers also occasionally relied on outside laboratory analysis. Some commercial laboratories provided “free” analysis in return for business generated from sale of chemicals needed to remedy pond ills. The Tungkang Marine Laboratory also provided analytical services.

## Bottom Maintenance

Bottom condition and maintenance were considered important by most farmers. The preferred method of maintenance was to remove the accumulation of black organic materials which had accumulated during growout. These reduced substances are most likely a combination of shrimp wastes (feces); uneaten food; dead plankton; and fine organic and inorganic bottom materials suspended by the currents generated by the aerators and resettled as discussed above. In ponds with circular currents, these materials settled and accumulated in the center of the pond.

After the final drain harvest the farmer would either flush this black material down the drain using a pressurized water hose or partially refill the pond with water and use a floating suction dredge to remove these accumulations. When a dredge was used the farmer contracted with individuals who specialized in this service. The cost was about \$63/0.25 ha (farm 8, Appendix A). Once the materials were removed, the pond was allowed to sun dry for about 2 weeks. If it doesn't rain, this is sufficient time to oxidize most of the surface materials and cause the bottom to crack. After the pond bottom dried, lime was applied to those areas which still had some organic accumulations. In most cases, powdered agricultural lime ( $\text{CaCO}_3$ ) was used, although a few farmers reported using quick lime ( $\text{CaO}$ ) or slaked lime ( $\text{Ca(OH)}_2$ ). The latter two are much more caustic and stronger oxidizing agents than powdered agricultural lime.

Lime applications rates varied. In most farms with dry ponds that were observed, the lime was applied in specific areas only, such as around the drain or in other "dark soil" areas (Figure 11). One farmer said he used a standard application rate of 100 kg  $\text{CaCO}_3$ /0.1 ha and applied "enzymes" to the soil (farm 3, Appendix A). No other information was discovered about the enzymes, but they are available from supply stores.

There is no evidence of acid soil problems, which are common elsewhere in Southeast Asia. Even if the soils were acidic in some cases, the high water flushing rates during growout would tend to leach out the acid.

## Chemical Use

The most prevalent chemical used in Taiwan shrimp farms is agricultural lime ( $\text{CaCO}_3$ ). This is used primarily to treat pond bottoms between crops, as discussed in the "Bottom Maintenance" section. Some farmers also used slaked lime ( $\text{Ca(OH)}_2$ ) or quick lime ( $\text{CaO}$ ), but these are less commonly used due to their more caustic properties.

Some people said organo-copper compounds are used to control algae and to promote shrimp molting, but this was not observed. However, bags of copper sulfate ( $\text{CuSO}_4$ ) were seen in commercial analytical laboratories, and it is likely that some farmers do use these compounds occasionally.

Teaseed cake is another chemical used by farmers to control fish intruders. At the proper concentration, teaseed cake is very effective at fish removal without ill effect on crustaceans (Minsalan and Chiu 1986).



*Figure 11. Concrete-walled ponds at farm 2. Lime has been spread on the dried bottom. The outlet pipes are on the right.*

### **Stocking Size, Density, and Seed Source**

On the average, farmers stocked 24-day-old postlarvae purchased from a commercial nursery (Table 3). Some farmers purchased PL5 and nursed these themselves or stocked them directly into growout ponds. In most cases, even farmers that had hatchery and/or nursery capabilities discontinued this practice for economic reasons. During 1984, PL5 cost had tumbled due to the large number of hatcheries and improved maturation/larviculture technology (Chiang and Liao 1985). PL5 costs reached a low of less than \$3/1,000 during 1985. By comparison, the cost of nursed PL20 to PL40 was about \$40/1,000, but most farmers felt this was a fair, competitive price. The consensus was that there was a high mortality rate between the PL5 and PL20 stage, plus the nursery operation was specialized, in addition to requiring more land and labor.

A few commercial nurseries were visited in the course of the study, but these visits were brief and outside the scope of this study. What was obvious from these short visits was the great care that the nursery operator takes in bottom preparation. All nursery ponds had a layer of coarse, black basaltic sand which had been imported to the farm. Between crops, the sand was washed clean with a garden hose and the bottom rolled flat with a lawn roller.

In almost all cases, the hatchery (maturation/larviculture), nursery, and pond growout were separate operations, owned and operated by separate businesspersons. It appeared even the maturation and spawning operation was generally separate from the larviculture operation; the latter normally reared the larvae to PL5 before they were sold to a nursery.

All of the farmers used a single-phased growout system once they had stocked the ponds with PL. That is, the shrimp were grown to market size in the pond that they were originally stocked in, without transfer to other ponds. This system was apparently used due to: the small farm sizes, which would make multiphasic growout difficult; a desire to reduce handling stress which would be associated with any transfer; and the relatively short growout time when using nursed PL.

Stocking densities ranged from 20 to 60 PL/m<sup>2</sup>, with an average of 34 PL/m<sup>2</sup> (Table 3). The two farmers who used the highest stocking density had younger PL, but there is no clear trend in the data between stocking density and PL age.

### Growing Season and Crops per Year

The growing season ranged from 8 to 12 months per year, with an average of 9.3 months (Table 3). Most farmers drained their ponds during the winter months (December through February) and left them dry. Those farmers who grew shrimp year round said they had warmer water conditions due to their geographical location. In Hawaii, ponds sheltered from the winds are typically 2° to 3°C warmer than windy ponds, so geographical location can make a difference. The amount of well water pumped daily into the ponds can also make a large difference. According to Hirasawa (1985), this is perhaps the main reason for extended shrimp growing seasons in Taiwan. Whatever the reason, the consensus among the farmers was that it should take about 3 to 4 months to bring a crop to market during the summer and 4 to 6 months during the winter.

Most farmers reported they got two crops/pond/year, while a few claimed between two and three crops/pond/year (Appendix A). Two crops is most realistic with an 8- to 9-month growing season.

Some farmers who raised shrimp year round said they sold their summer crop for export to Japan, while the winter crop was for local domestic consumption. One farm raised milkfish for sale to tuna fishermen during the off-season.

### Harvest Size and Price

The average size at harvest ranged from 29 to 36 g per whole shrimp, with an average size of 31.5 g (Table 3).



The average price pond side, paid to the farmer for whole-bodied shrimp was about \$6.25/kg (\$2.84/lb) but ranged from \$5.75 to \$6.88 /kg (\$2.61 to \$3.13/lb) depending on size, season, and other market factors (Appendix A). All farmers sold directly to wholesalers.

### Crop Yields

Reported crop yields per year ranged from 4,800 to 20,600 kg/ha (Table 3). When stocking rates, survival, and size at harvest are compared with yield data provided by the farmers, only five of the 11 farms provided information that had no discrepancies. Of the five consistent data sets, the annual yields ranged from 10,000 to 20,600 kg/ha (9,167 to 18,883 lb/acre). Yield estimates from the three best farms which had consistent data averaged 16,867 kg/ha/year (15,461 lb/acre/year).

Survival rate from PL stocked to harvest ranged from 60% to more than 90% based on the farmers' estimates. Based on stocking rates and harvest data, average survival is calculated to be in the 70% to 80% range. Perhaps 75% is a good estimate on the average.

If yield estimates are constructed from an "average," well-run farm, there would be: stocking densities of 34 PL<sub>24</sub>/m<sup>2</sup>/crop; survival of 75% to harvest; and average size per shrimp of 31.5 g. These values yield standing crops of 803 g/m<sup>2</sup>, or 8,030 kg/ha/crop. With two crops per year, the annual yield is 16,060 kg/ha (14,722 lb/acre/year). It is believed that this yield value is a realistic expectation for a moderately well-run, intensive tiger prawn farm of the size and type surveyed.

It should be mentioned that the production figures shown in Table 3 were for the previous year's production. In some cases, there were fewer ponds in production at some of the farms than during the survey, or for some reason, the ponds were not in full production. This causes some discrepancies between stocking, survival, and yield values.

Often farmers undoubtedly gave us "best case" values or values based on what they thought they should produce.

### Feed and Feed Conversions

All farmers fed their shrimp a high-quality, formulated feed. In addition to formulated feeds, some of the farmers also used trash fish, but this was not common. Trash fish presented a handling and storage problems, as well as a potential water quality problem. Most farmers used formulated feeds only.

There are more than 30 feed companies in Taiwan (Chiang and Liao 1985), with strong competition for sales. The feed suppliers deliver to the farm as part of the sales price. Formulated feeds cost about \$0.88/kg (\$0.40/lb) delivered to the farm in bags.

Feed conversion (kg feed applied/kg shrimp harvested) estimates ranged from 1.4 to 1.9, with an average of 1.7 (Table 3).

Although there are feeding rate formulas that are a function of shrimp size and pond biomass, these serve only as guides. In practice, feeding is adjusted daily by observing feed consumption in feed nets or trays (Figure 12). Feed is applied to the pond, while a measured quantity is placed in the feed net. Perhaps an hour or less later, the feed net is retrieved and the amount of feed consumption observed. If all feed is consumed, the feeding rate may be increased. If feed remains in the net, the feeding rate is reduced. This system is based on feed demand, which is related to both shrimp biomass and shrimp appetite, as affected by such things as water temperature and quality.

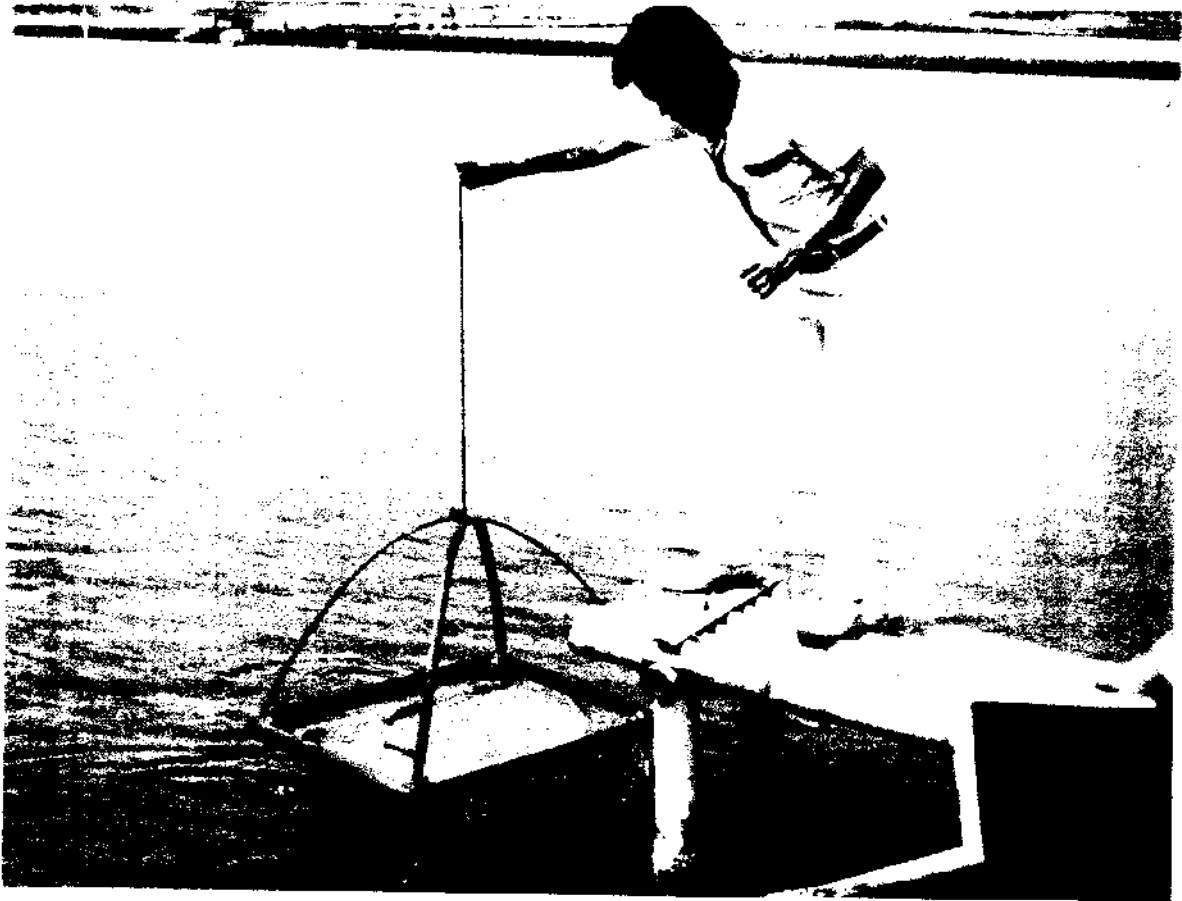

*Figure 12. Feed net used to measure feed consumption rate of prawns.*

## Harvests

Most farmers do not harvest by themselves. Instead, they decide on a harvest date, based primarily on the size and condition of the shrimp. Once a harvest date is set, the farmer will call several wholesalers to obtain the best price. Once the price is settled, the farmer contracts with a wholesaler to buy the crop. The wholesaler then contacts the harvesters, who act as independent operators. The harvesters, with their own harvest nets, will arrive at the farm on the harvest date.

One harvest observed was of a 1 ha pond. There were six harvesters, each with an electric harvest net. The net was constructed like a beam trawl, with a mouth width of about 3.5 m (11.5 ft). The harvesters pulled the net about the pond by means of a body harness and tether (Figures 13 and 14). They usually worked in a group of two or three and walked abreast in a broad circle around the pond (Figure 15). The net had a bare copper wire along the foot, attached to a 6-volt battery which the harvesters pushed on a styrofoam float (Figure 13). The electric current was pulsed through the copper wire by a "vibrator," which was kept in the battery box. After the net harvesters completely circled the pond, they arrived back at the edge of the pond near the wholesalers truck and scale. The "beams" of the net mouth were placed above water on a bent iron stake which had been driven into the bottom (Figure 16). This kept the mouth of the net above water, so that the shrimp could not escape. The shrimp were then worked back into the bag end of the net, which was placed into a harvest basket. The bag end was untied, and shrimp were put into the basket. The basket, which had a net on top to prevent the shrimp from jumping out, was then passed to shore where the shrimp were sorted to remove debris, damaged shrimp, and diseased shrimp (Figures 17, 18, and 19). A fiberglass sorting bin with holes in the bottom was used to sort the shrimp. They were put back into the harvest basket and weighed, with the weight checked by the farmer or his employee. The basket was then passed to the wholesalers truck where the shrimp were iced down for transit to a processing plant (Figures 20 and 21).

Before the net harvest began, the pond water level was lowered by 1/2. Following the net harvest, the level was raised to the full depth again for 1 week, at which time the entire pond was drained and shrimp collected with the effluent water. The reason given for refilling and waiting 1 week was that the draw-down and net harvest stress the shrimp and cause them to molt. If they were to do a drain harvest immediately following the net harvest, there would be a high percentage of soft-shelled shrimp, which bring a lower price than hard-shelled ones. According to the farmer, about 90% of the shrimp are harvested by net harvest, while the remaining 10% is harvested a week later during the drain.

The net harvesters are paid by the amount of shrimp each catches. The price is \$0.042/kg (\$1 (N.T.)/Taiwan kg).

### Problems

Most farmers indicated they did not have any major problems. They were all making money. If they would indicate problems at all, it was with water quality and disease. Most farmers were not very specific about water quality problems they had, although two mentioned salinity control and high summer water temperatures. The salinity control problem was due to the farm location (farm 8, Appendix A). The main disease problem appeared to be related to a red coloration of shrimp. The cause of this is apparently unknown, although it is thought to be disease related.

Sinking land due to groundwater overdraft and typhoons were also mentioned by some farmers as problems.

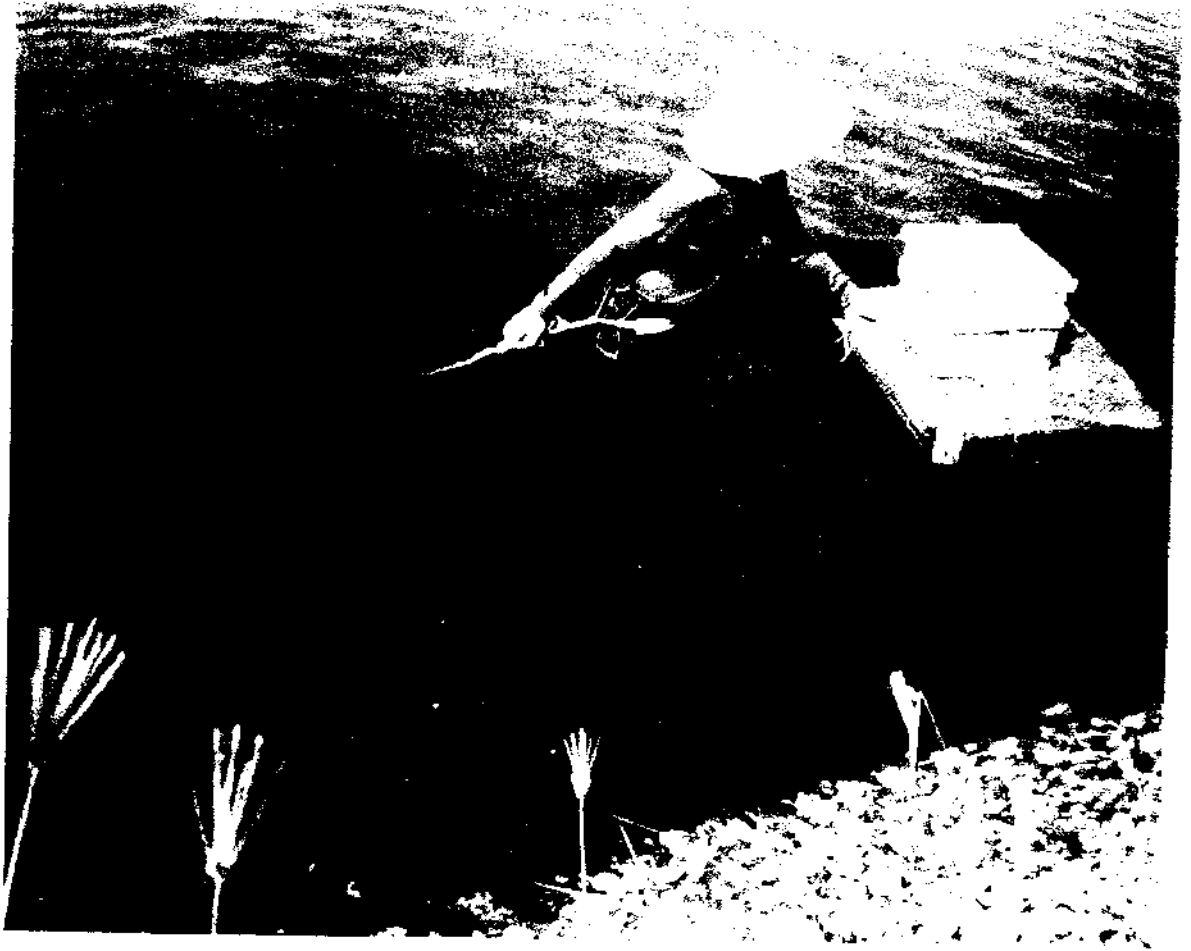

*Figure 13. Harvester towing an electric harvest net. The battery and vibrator are pushed ahead of the harvester on a styrofoam float. The harvester pulls the net by means of a harness.*



*Figure 14. Harvester pulling electric harvest net between a 2-hp paddlewheel aerator and the shore. The "beam" keeps the net open during towing.*



*Figure 15. Four harvesters pulling their electric harvest nets around a pond during harvest.*

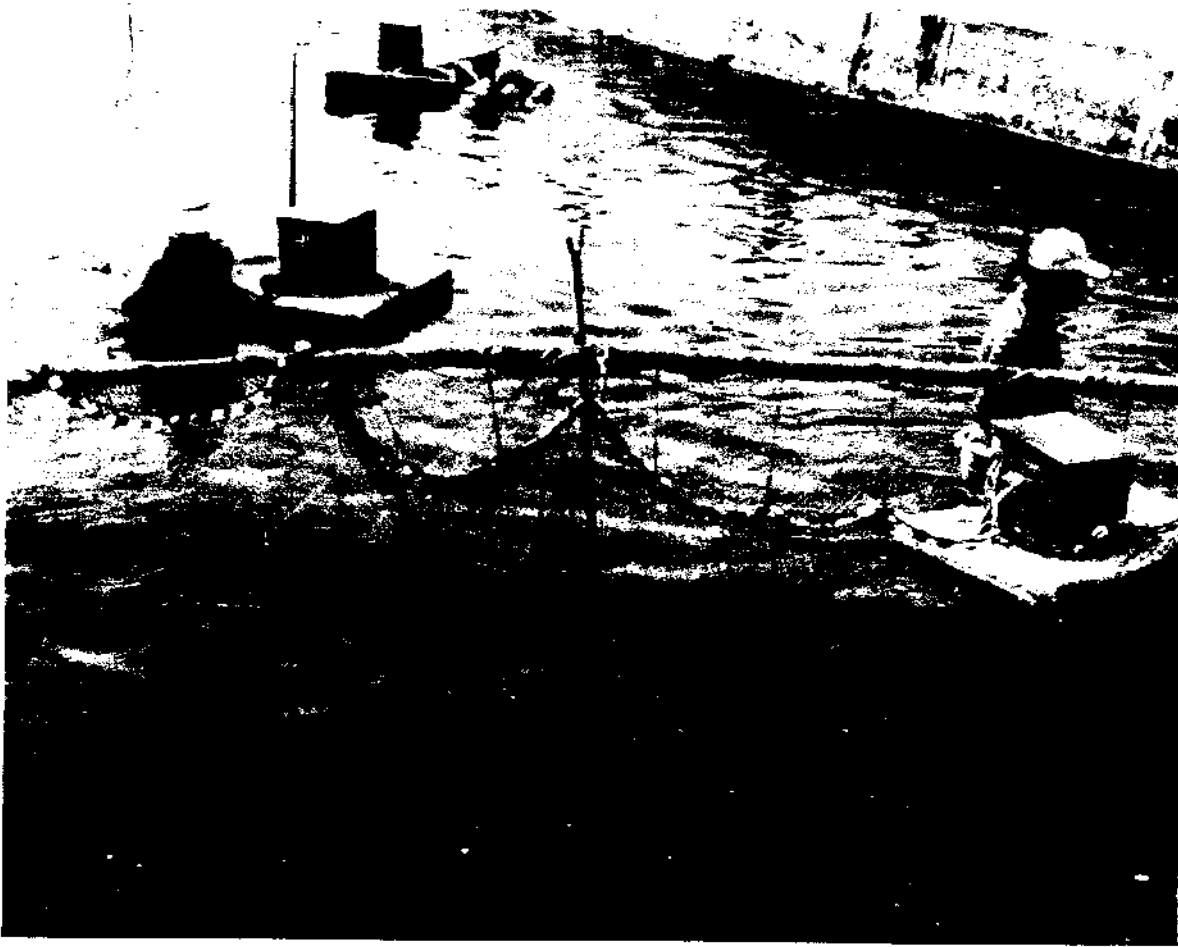
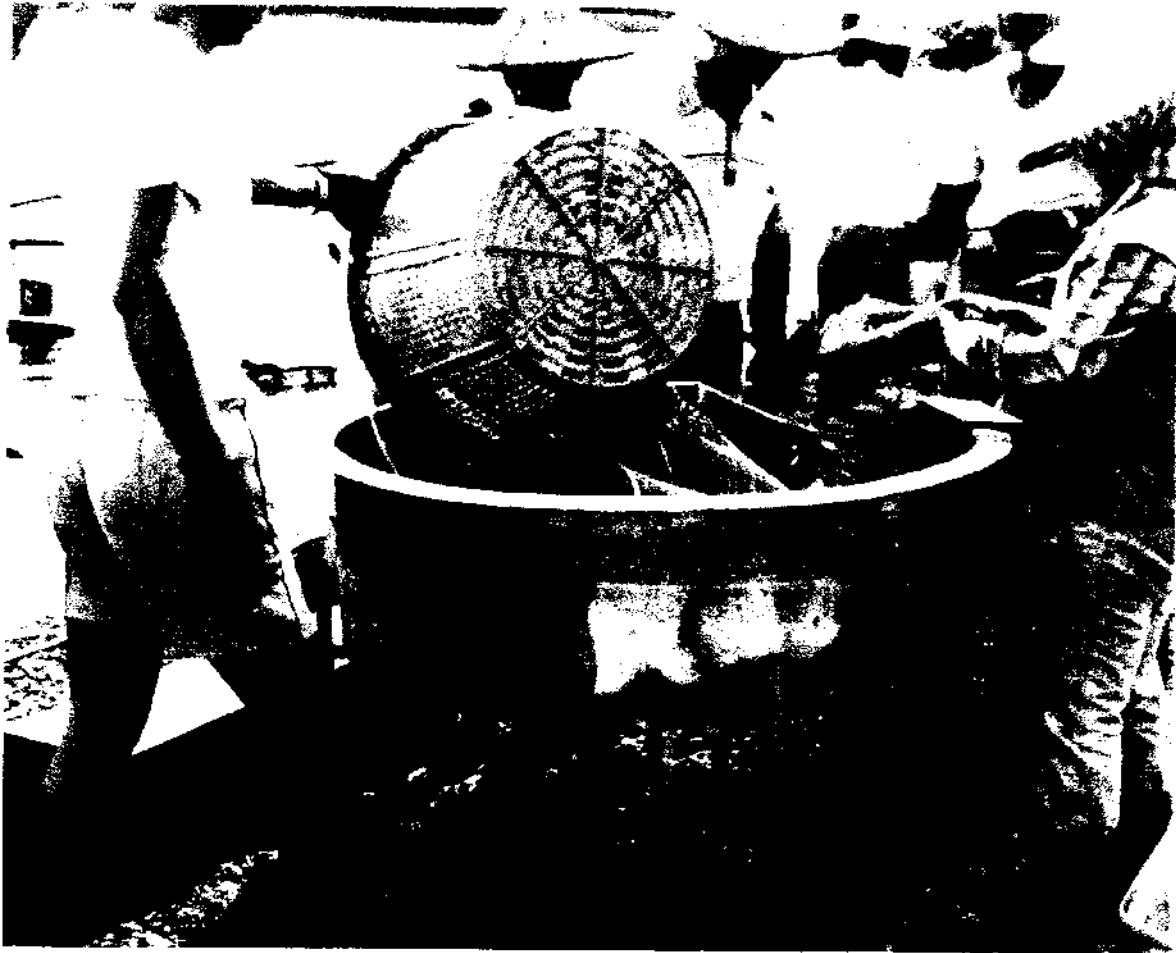

*Figure 16. Electric harvest net propped up on a metal support pipe near the weighing station. Shrimp are removed through the bag end of the net into harvest baskets.*



*Figure 17. A harvest basket is lifted from the pond after shrimp are transferred into the basket from the electric harvest net.*





*Figure 18. Shrimp being placed from harvest basket into sorting container. The fiberglass container has a perforated bottom for water drainage and a "spout" through which the shrimp are pushed as they are inspected and put back into the harvest basket.*



*Figure 19. Penaeus monodon being sorted to remove debris, damaged shrimp, and diseased shrimp before weighing. Sorted shrimp are pushed into harvest basket as they are inspected.*



*Figure 20. Shrimp in harvest basket being weighed after being sorted.*

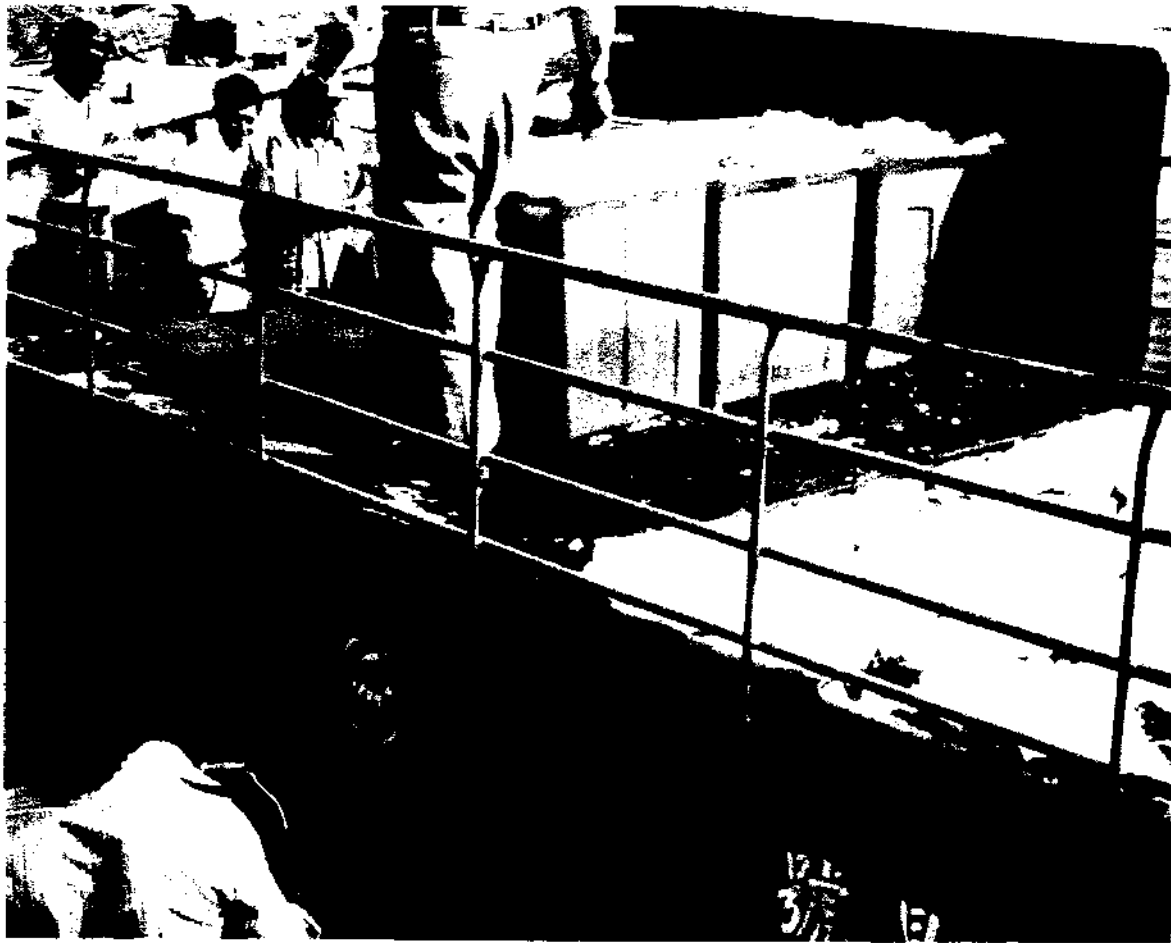

*Figure 21. Shrimp are loaded into plastic containers and iced for shipment to the processing plant after weighing.*

## Labor

Most farms are run by family members. When they exceed a certain size, or need extra help, such as bottom cleaning between crops, they hire on a per day basis. Manual labor costs were about \$12.50 to \$15.00/day/person and paid on a cash basis.

## ECONOMIC ANALYSIS

The following questions will be addressed in this section:

1. How are the Taiwan shrimp farms doing financially?
2. Would it be economically feasible for Hawaii shrimp farmers to adopt Taiwan technology?
3. What production areas need improvement in Hawaii to make intensive shrimp farming there more profitable?

In order to answer these questions, costs of production, both in Taiwan and Hawaii were estimated based on the survey and literature.

### Construction Costs

Based on a study by Chiang and Liao (1985), the cost of concrete-walled pond construction in Taiwan is estimated at \$44,100/ha. In Hawaii, construction costs were estimated separately for earthen and concrete ponds, both with 4-ha water surface area and built in Taiwan style. The earthen pond farm consisted of eight square ponds, each 1/2-ha water surface area and 2 m deep. The farm with concrete walls consisted of 16 square ponds, each 1/4-ha water surface area and 2 m deep. The pond layout and cost calculations are shown in Appendixes B and D. The costs of construction for both type of ponds in Hawaii are summarized in Table 4.

### Operating Costs

Annual operating costs per ha in Taiwan and Hawaii are detailed in Table 5. Annual production costs in Taiwan refer to concrete pond operation, while in Hawaii, it is divided into earthen and concrete pond operation. Two crops per year was assumed in Taiwan and 2.5 crops in Hawaii.

### Seed

Postlarvae, the most important cost item both in Taiwan and Hawaii, ranged from 23% to 35% of the total operating cost. A stocking rate of 34 PL/m<sup>2</sup> and a survival rate of 75% were assumed. Cost of seed used in the calculation was \$40/1,000 PL for PL 20 days old or older.

TABLE 4. ESTIMATED INITIAL CAPITAL INVESTMENT FOR A 4-HA (WATER SURFACE AREA) EARTHEN AND CONCRETE POND FARM IN HAWAII

	Earthen Pond Farm (\$)	Concrete Pond Farm (\$)
<b>Construction Costs</b>		
Permit*	30,000	30,000
Excavation	121,470	6,300
Concrete Work	—	558,600
Electrical Installation	18,000	25,200
Pipes		
Supply/Discharge	54,800	—
Plumbing	—	73,500
Design (5%)	11,435	36,268
House	60,000	60,000
Storage/Office	8,000	8,000
Well†	30,000	30,000
Miscellaneous (Road/Fence)	10,000	10,000
Subtotal	343,705	837,868
<b>Equipment Costs</b>		
Pumps	15,000	15,000
Aerators	14,400	14,400
Subtotal	29,400	29,400
<b>TOTAL COST</b>	<b>373,105</b>	<b>867,268</b>

\*W. A. Brewer, William A. Brewer & Associates, 1987: pers. com.

†Assume the equivalent of four 10-hp wells, 25 feet deep and costs per foot figures from Shang (1981)

TABLE 5. ESTIMATED ANNUAL OPERATING COST PER HA POND ON A 4-HA (WATER SURFACE AREA) FARM

	Taiwan (2 crops/year)		Hawaii (2.5 crops/year)			
	Concrete Pond		Earthen Pond		Concrete Pond	
	(\$)	(%)	(\$)	(%)	(\$)	(%)
Seed <sup>*</sup>	27,200	35	34,000	26	34,000	23
Feed <sup>†</sup>	22,400	29	28,050	22	28,050	19
Labor <sup>‡</sup>	5,000	7	18,213	14	18,213	12
Harvest <sup>§</sup>	630					
Electricity <sup>*</sup>	5,194	7	15,538	12	15,538	10
Chemicals	1,600	2	2,000	2	2,000	1
Land Lease <sup>@</sup>	4,000	5	7,178	6	5,127	3
Interest <sup>**</sup>	5,292	7	11,493	9	26,468	18
Depreciation <sup>††</sup>	2,205	3	5,946	5	11,998	8
Sales Tax <sup>^^</sup>			586		586	
Miscellaneous <sup>§§</sup>	3,676	5	6,075	5	7,108	5
<b>TOTAL</b>	<b>77,197<sup>**</sup></b>		<b>129,079</b>		<b>149,088</b>	

\*For Taiwan: 10,000 m<sup>2</sup> x 34 PL/m<sup>2</sup> x \$40 per 1,000 PL x 2 crops/year.

†Production of 15,000 kg of shrimp/year x 1.7 feed conversion rate x \$0.88/kg of feed.

‡For Taiwan, survey data; for Hawaii: 1 manager and 2 laborers plus 3 additional laborers for harvest. Salary for manager was assumed \$25,000/year plus 25% fringe benefits, and for laborer \$16,000/year plus 15% fringe benefits. Wage rate for hired laborer was \$5/hour.

§Cost \$0.042 per kg.

\*For Taiwan, survey data; for Hawaii see Appendix C.

@For Taiwan Calculated by using the opportunity cost of land value of \$79,000/ha. For Hawaii: Calculated at 3.5% of gross farm income. A 4-ha earthen pond farm needs 7 ha of land, and a 4-ha of concrete pond farm needs 5 ha of land.

\*\*Calculated at 12% interest rate of capital investment.

††20-year life for facilities; 4-year for aerators; 6-year for pumps.

^^0.5% gross income tax for farm sales.

§§5% of operating cost.

\*\*1985 exchange rate: \$1.00 = \$40 (N.T.)

## Feed

Feed, the second most important cost item in Taiwan and Hawaii, ranged from 19% to 29% of the total operating cost. A feed conversion ratio of 1.7:1 and feed cost of \$0.88/kg were used in the calculations.

## **Labor**

Labor cost in Hawaii includes wages for one manager, two fulltime laborers, and three short-term laborers for harvesting. In Taiwan, harvesting is done by a specialized firm charging \$0.042 per kg of shrimp harvested.

## **Electricity**

Electricity costs mainly include costs for pumping and aerating (see Appendix C for detailed calculations).

## **Chemicals**

Costs include chemical for pond sterilization, fertilization, and curative medicines.

## **Land Lease**

Land lease in Taiwan was calculated by using the opportunity cost of land value of \$79,200/ha. In Hawaii, it is calculated at 3.5% of the gross farm income. For a 4-ha (water surface area) earthen pond farm, a total of 7 ha of land is needed, while a total of 5 ha of land is needed for the same farm size with concrete ponds.

## **Interest**

A 12% interest rate on initial capital investment was used in the calculation. In Taiwan, capital investment was estimated at about \$44,100/ha, while in Hawaii, it amounted to about \$95,776 and \$216,817 per 1 ha pond, respectively, for earthen and concrete ponds.

## **Depreciation**

A useful life of 20 years was assumed for ponds and other facilities and 6 years and 4 years, respectively, for pumps and aerators.

## **Summary of Analysis**

An average yield of 7,500 kg/ha/crop and a farm price of \$6.25/kg were assumed in Hawaii and Taiwan. The gross revenue and profit per ha are estimated as:



	Taiwan	Hawaii	
		Earthen Ponds	Concrete Ponds
Production/ha/year	15,000 kg	18,750 kg	18,750 kg
Farm price/kg	\$6.25	\$6.25	\$6.25
Gross Revenue	\$93,750	\$117,188	\$117,188
Cost of Production	\$77,197	\$129,079	\$149,088
Profit/ha/year	\$16,553	(-\$11,891)	(-\$31,900)

The results of the above calculations indicate shrimp farmers in Taiwan are doing well financially, on the average, with about \$16,500 annual profit per ha. The adoption of Taiwan intensive operations in Hawaii does not appear to be profitable unless the production level can be increased and/or production costs can be reduced. Increase in yield can be achieved by increasing the number of crops per year and/or by increasing the survival rate. Yield and profit per ha can also be increased by an increase in survival rate, provided there are no significant increases in costs.

By comparing the costs of production between Taiwan and Hawaii, it is apparent that costs of labor and electricity in Hawaii are about three times higher than those in Taiwan. Interest and depreciation also cost two to five times more in Hawaii (depending on type of pond) mainly because of higher construction costs. Efforts in reducing these costs are necessary.

In Hawaii, the costs of construction of concrete ponds are more than double that of earthen ponds. The concrete pond operation is unlikely to be justified economically in Hawaii unless the high construction cost can be offset by other costs and higher yield.

## DISCUSSIONS AND CONCLUSIONS

The intensive shrimp culture industry in Taiwan is characterized by small farm size (3.9 ha [9.4 acres]) and family-run operations. Hatcheries, farms, feed companies, harvesters, wholesalers, processors, and equipment suppliers are typically separate business operations, without vertical integration.

In the United States, agricultural farms tend to be large, corporate operations with a high degree of vertical integration of production and marketing components. Although the U.S. shrimp farming industry has not evolved sufficiently to characterize its form, most likely the tendency will be for large, corporate operations with vertical integration. Shrimp farms in Ecuador are mostly of this type.

Intensive culture of tiger prawns in Taiwan is clearly profitable. This was obvious from discussions with farmers, from the impressive growth of the industry, and from the economic analysis. Even small farmers are making a good living growing prawns in Taiwan.

By comparison, the simulated transfer of the Taiwan shrimp culture technology to Hawaii yields unprofitable projections. The main reasons for the negative profit in Hawaii are the high costs of labor, electricity, and construction in Hawaii and the United States in general. In Hawaii, on a per hectare basis, labor costs \$18,213/year, or 12% of annual operating costs (Table 5, Figure 22). Labor in Taiwan is only \$5,000/ha/year. Similarly, electricity costs \$15,538/ha/year in Hawaii, compared with only \$5,194/ha/year in Taiwan. Interest and depreciation on capital investments total \$38,466/ha/year and \$17,439/ha/year for concrete and earthen ponds in Hawaii, compared with \$7,497/ha/year for concrete ponds in Taiwan. The high construction costs in Hawaii reflect indirectly the very high labor and "contractual" costs in the United States and the added cost of permits in Hawaii. There are no permit costs in Taiwan.

Production cost for earthen ponds in Taiwan was not estimated because of inadequate data but from observations, earthen ponds are more profitable than concrete ponds in locations where earthen ponds can be built.

If shrimp cultured in the United States is ever to be cost competitive with shrimp cultured in such places as Taiwan, the United States must reduce labor, energy, and farm construction costs. These reductions, perhaps coupled with large, corporate shrimp farm size and vertical integration, could make U.S.-cultured shrimp competitive on the world market. The key is to develop appropriate technology in the United States which will reduce labor and energy consumption, while keeping risk of crop loss low.

At 1985 labor and energy unit cost differentials between the United States and Taiwan, total labor and energy costs of shrimp production in the United States needed to be reduced by 72.5% and 66.6% respectively in order to bring them in line with Taiwan conditions. These reductions in U.S.-operating costs alone would make shrimp farming in the United States profitable. Further profits would be realized if labor, permitting, and other costs to construct a shrimp farm in the United States could be reduced. It will be much more difficult to reduce the latter costs than the operating costs because the latter costs (especially construction labor) are more intrinsically bound by social conditions in the United States.

Steps can be taken in the United States to reduce both labor and energy consumption of Taiwan intensive shrimp farms. Cost reducers include:

1. *Design of farms and equipment that minimize labor to feed, harvest, and maintain facilities.* Automated or semiautomated feeding systems could greatly reduce the feed-labor component. Harvest labor requirements could be reduced through the development of drain harvest techniques in which the shrimp "run" with the water and are removed from the drain water through the use of live fish pumps and sorting tanks. Some shrimp, such as tiger prawns, tend under certain conditions to burrow in the mud rather than run with the drain. A better understanding of this behavior, as related to the time of drain, drain outlet design, draining rate, and/or some other condition could lead to all of the shrimp running with the drain water. This understanding alone will greatly reduce harvest-labor needs and, coupled with improved sorting and

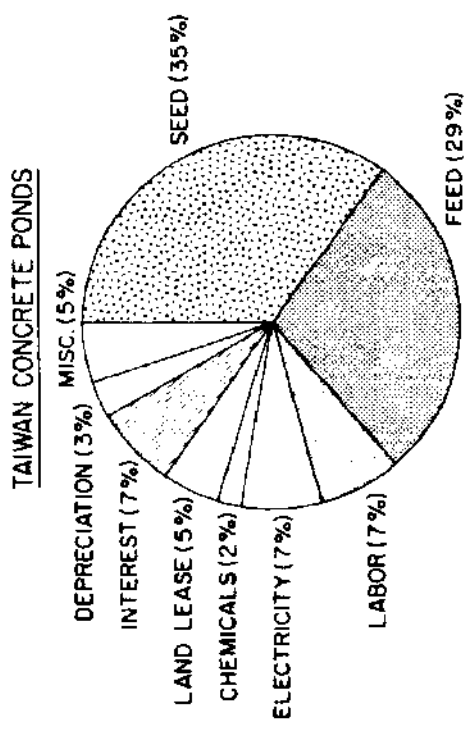
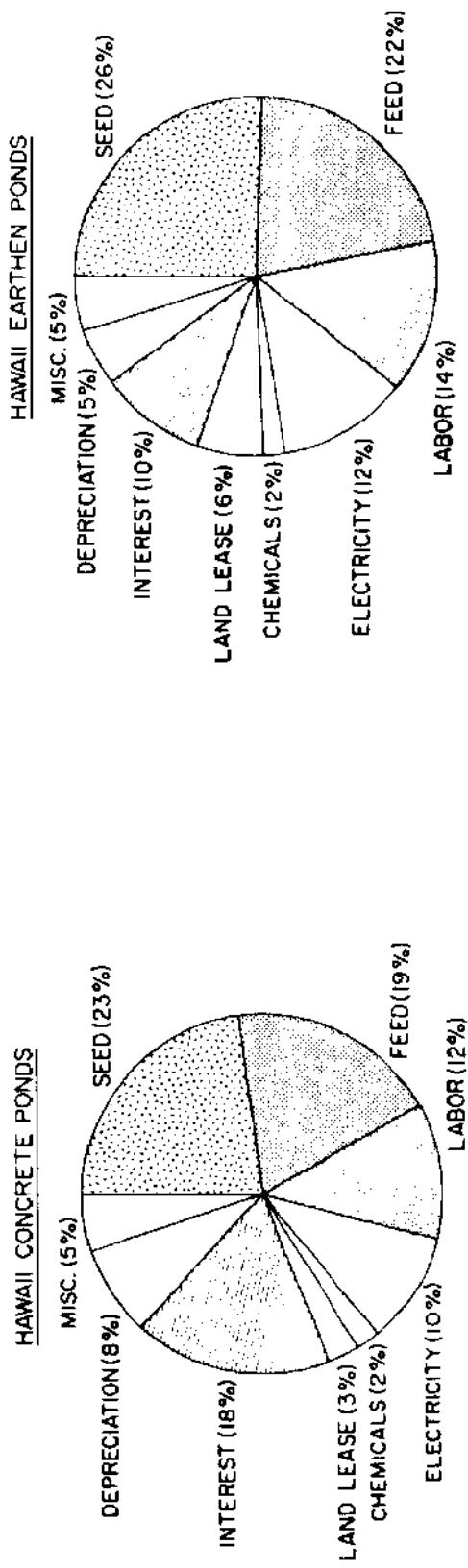

Figure 22. Pie charts of costs as percentages of total production costs for Taiwan concrete ponds and simulated concrete and earthen ponds in Hawaii (see Table 5).

cleaning such as with live fish pumps and live tanks, will further reduce harvest-labor costs while maintaining a premium product.

Another aspect of farm design which affects labor and perhaps energy consumption is farm size. Should the farm be designed for a single family, or for larger corporate operation? If the former, should they be clustered into cooperatives in order to realize economics of scale, while realizing economics of efficiencies associated with smaller farms?

Maintenance of farm equipment and premises (e.g., grass cutting) can consume large amounts of labor. Steps need to be developed to minimize these labor consumers.

2. *Develop a better understanding of pond dynamics processes and quantification of the need for water exchange.* The following relationships need to be better understood: (1) shrimp survival and growth; (2) algal species composition, algal densities, and algal photosynthesis and respiration; (3) the accumulation of metabolites and other substances in the water which affect shrimp; (4) sediment deposits and bottom soil conditions; and (5) water temperature and salinity. A better understanding of these relationships should lead to the development of pond management practices which maximize shrimp yield, while reducing labor and energy costs through reduced needs for aeration and water exchange.

Whether or not a thorough understanding of these pond dynamics processes is achieved, the need for water exchange must be better quantified. Water exchange accounts for more than 60% of the energy costs, while aeration accounts for most of the remaining energy costs (Appendix C). Currently, pumping schedules are highly subjective. While there is not a good understanding of the parameters involved, it is known that water exchange, especially during periods of high shrimp standing crop and high feed applications, is essential for the maintenance of suitable water quality and shrimp yield. It may be possible to develop criteria for water exchange which achieve the desired results, while greatly reducing water exchange and energy consumption. This may also reduce the need for aeration as well, thus resulting in additional energy savings.

3. *Apply microcomputer technology to standard pond management operations such as water quality monitoring, feeding, aeration/circulation operation decisions, and water exchange decisions.* All but the last item have been quantified or sufficiently understood so that microcomputers can be used for these purposes. Such applications, perhaps more than any other activity, should result in the necessary labor and energy savings needed to make U.S.-cultured shrimp competitive on the world market.

All of the above items, if successful, will reduce labor and energy requirements to grow shrimp in the United States. These are, however, not the only items which need attention. The analysis of operating costs indicate seed and feed costs account for about 50% of the total operating costs (Table 5; Figure 22).

Although seed production is no longer considered a technical constraint for shrimp culture, it is a major operating cost. Seed costs of \$40/1,000 for PL20 or older account for 35% and 27% of operating costs in Taiwan and Hawaii respectively. These costs are high compared with other countries of Southeast Asia, where prices for comparable PL are less than half this amount. In the United States, there may also be high costs for this sized PL due to the anticipated need for closed cycle seed production. Seed production costs need to be reduced in the United States.

Shrimp feed costs of \$0.88/kg (\$0.40/lb) account for 29% and 22% of projected operating costs of tiger prawns in Taiwan and the United States respectively. Compared with U.S. feed costs for other species such as rainbow trout (*Salmo gairdneri*) and channel catfish (*Ictalurus punctatus*), in which nutritional needs are better defined, shrimp feed costs are excessively high. Good quality trout and catfish feeds are now produced in the United States at retail prices of about \$0.22 and \$0.18/lb respectively, with feed conversions in the range of 1.1 to 1.5. Perhaps a better understanding of shrimp nutritional needs and alternative feed substances will reduce shrimp feed costs as well.

There are many other items which could affect shrimp culture profitability. A thorough discussion of all of these is beyond the scope of this study. It is believed, however, that this study identifies the major items now causing U.S.-cultured shrimp to be economically uncompetitive with shrimp cultured elsewhere. It is hoped research and development efforts on these priority items will resolve these impediments and thus place U.S.-grown shrimp on a competitive basis in the world market.

## REFERENCES

- Anonymous. 1987. Shrimp culture in Ecuador. In *Acuacultura del Ecuador*. Publicacion de la Camera de Productores de Camaron. Numero 3, Enero de 1987. Guayaquil, Ecuador.
- Apud, F., J. H. Primavera, and P. T. Torres, Jr. 1983. *Farming of prawns and shrimps*. Extension Manual No. 5 (34d edition). Aquaculture Department, Southeast Asian Fisheries Development Center, Tagbayan, Iloilo, Philippines.
- Asian Development Bank. 1983. *The international shrimp market for shrimp*. ADB/FAO Second Fish Market Study, Vol. 3. Manila, Philippines. 79 pp.
- Chiang, P., and I-Chiu Liao. 1985. The practice of grass prawn (*Penaeus monodon*) culture in Taiwan from 1968 to 1984. *J. World Maric. Soc.* 16:297-315.
- Colvin, L. B. 1985. Intensive growout systems for shrimp. In *Texas Shrimp Farming Manual*, ed. G. W. Chamberlain, M. G. Haby, and R. J. Miget, pp. IV-1/14. Texas Agri. Ext. Service, Corpus Christi, TX.
- Hirasawa, Y. 1985. Economics of shrimp culture in Asia. In *Proceed. First Int. Conf. Cult. Penaeid Prawns/Shrimp*, ed. Y. Taki, J. H. Primavera, and J. A. Llobrera, pp. 131-150. SEAFDEC, Iloilo City, Philippines.

- Hornung, W. J. 1986. *Estimating Building Construction Quantity Surveying*. Englewood Cliffs: Prentice Hall.
- Hudinaga, M. 1942. Reproduction, development, and rearing of *Penaeus japonicus* Bates. *Jpn. J. Zool.* 10:305–393.
- Kurata, H., K. Yatsuyanagi, and K. Shigueno. 1980. Kuruma shrimp culture in Japan. UJNR, Aquaculture Panel 9th Joint Meeting. Mimeographed. 7 pp.
- Lawrence, A. L. 1985. Marine shrimp culture in the western hemisphere. In *Proceedings of the Second Australia National Prawn Seminar*, ed. P. C. Rothlisberg, B. J. Hill, and D. J. Staples, pp. 327–335. Kooralbyn, Australia.
- Lawrence, A. L., M. A. Johns, and W. L. Griffin. 1984. *Shrimp mariculture, state of the art*. TAMU-SC-84-502. Texas A&M University Sea Grant.
- Liao, I-Chiu. 1985. General introduction to the prawn system in Taiwan. Contribution B No. 34 from the Tungkang Marine Laboratory. Presented at Joint US-ROC Workshop on Aquaculture Engineering and Simulation, Honolulu, Hawaii, January 27–February 1, 1985.
- Liao, I-Chiu. 1987. Future technology in prawn production. Contribution B No. 51 from the Tungkang Marine Laboratory. Presented at the Special Session, the 18th Annual Meeting of the World Aquaculture Society, 18–23 January 1987, Guayaquil, Ecuador.
- Liu, M. S., and V. J. Mancebo. 1983. Pond culture of *Penaeus monodon* in the Philippines: Survival, growth and yield using commercially formulated feed. *J. World Maric. Soc.* 14:75–85.
- Macaulay, P. J., K. C. Samples, and Y. C. Shang. 1983. Assessing the performance of market distribution channels for aquaculture products: The case of Hawaii produced marine shrimp. In *Proceed. 1st Int. Conf. on Warm Water Aquaculture Crustacea*, ed. G. L. Rogers, R. Day, and A. Lim, pp. 34–45. Brigham Young University Hawaii Campus, Laie, Hawaii.
- Minsalan, C. L. O., and Y. N. Chiu. 1986. Effects of teaseed cake on selective elimination of finfish in shrimp ponds. In *Proceedings of the First Asian Fisheries Forum, Asian Fisheries Society, Manila, Philippines*, ed. J. L. Maclean, L. B. Dizon, and L. V. Hosillos, pp. 79–82.
- New, M. B., and H. R. Rabanal. 1985. A review of the status of penaeid aquaculture in South East Asia. In *Second Australian National Prawn Seminar*, ed. P. C. Roghlisberg, B. J. Hill, and D. J. Staples, pp. 307–326.
- Primavera, J. H. 1985. A review of maturation and reproduction in closed thelycurn penaeids. In *Proceed. First Int. Conf. Cult. Penaeid Prawns/Shrimp*, ed. Y. Taki, J. H. Primavera, and J. A. Llobrera, pp. 47–64. SEAFDEC, Iloilo City, Philippines.

- Salser, B., L. Mahler, D. Lightner, J. Ure, D. Danald, C. Brand, N. Stamp, D. Moore, and B. Colvin. 1978. Controlled environment aquaculture on penaeids. In *Drugs and Food From the Sea*, ed. P. N. Kaul and C. J. Sindermann, pp. 345–355. University of Oklahoma, Norman, Oklahoma.
- Shang, Y. C. 1981. *Freshwater prawn (Macrobrachium rosenbergii) production in Hawaii: Practices and economics*. UNIH- SEAGRANT-MR-81-07. University of Hawaii Sea Grant College Program, Honolulu.
- Shigueno, K. 1985. Intensive culture and feed development in *Penaeus japonicus*. In *Proceed. First Int. Conf. Cult. Penaeid Prawns/Shrimp*, ed. Y. Taki, J. H. Primavera, and J. A. Llobrera, pp. 115–122. SEAFDEC, Iloilo City, Philippines.
- Veloso, A. P. 1984. San Miguel Corporations' initial venture into aquaculture in the Philippines. Paper presented to AIESEC Symposium on Agri-business Development Strategies for the Philippines, January 19, 1984. Manila.
- Wiles, G. 1984. Shrimp production poised to take lead role in Hawaii aquaculture. *Pac. Bus. News* (Nov. 12).

## **APPENDIXES**



## **Appendix A. Summary of Taiwan Farm Survey Data Sheets**

These data sheets are summaries of the survey farms and not copies of the original forms. A total of 11 farmers were interviewed during the survey from September 16 to September 21, 1985. Farms are listed by number to protect individual identities.

FARM SURVEY SUMMARY SHEET

Farm No. 1 Date Interviewed 9/16/85  
 Number of years experience by manager 6  
 Number of years farm used to raise shrimp 6  
 Company operated X Family operated \_\_\_\_\_  
 Number and size of ponds: eleven 1,000 m<sup>2</sup> ponds (35x33 m) = 1.1 ha  
 (like San Maqual in Philippines).  
 Water Depth 1.5 - 2.0  
 Drain: Center X Side \_\_\_\_\_ Corner \_\_\_\_\_  
 Dike: Concrete X Earthen \_\_\_\_\_  
 Bottom: earth and imported sand  
 Water Supply: FW - 10 hp; SW - 3 three, 10 hp  
 \_\_\_\_\_ Total HP: 20 hp  
 Aeration: 2 Paddlewheels per pond  
 \_\_\_\_\_ Total HP: 22  
 Water Salinity: Aver. 18-19 (Range 15-20)  
 Use D.O. meter for oxygen measurement: Yes X No \_\_\_\_\_  
 Cost for electricity: \_\_\_\_\_  
 \_\_\_\_\_  
 Aeration Schedule: Shrimp > 20 g aerate continuous.  
< 20 g, aerate each night from 1100 - 1200 hrs to dawn.  
 Stocking: Size PL 20-30 Source Commercial nursery  
 No./m<sup>2</sup> 30-40  
 Growout: Season 12 mo; but grow slower in winter  
 Average Crop time per crop 4 mo summer / 6 mo winter  
 Feed: Cost \_\_\_\_\_ Feed Conversion \_\_\_\_\_  
 Chemicals: tea seed cake, lime  
 How is bottom treated: hose down; dry for 2 weeks between crops; use  
lime as needed (agricultural lime)  
 Labor: 1 manager/worker who lives on-site.  
 \_\_\_\_\_  
 Harvest Costs: \$ .042/kg  
 Size at harvest: Aver. 30 g (Range 20-40)  
 Survival Rate: 70-80% Price: \$6.25/kg  
 Total Production last Year: 7.2 tons (but not all 11 ponds in production)  
 Average crops per year: 2 - 3  
 Other costs: Land today \$50,000 - \$100,000/ha for best  
 Problems: disease; water quality  
 \_\_\_\_\_  
 Comments: Shrimp smaller than 29 g sell for \$5.62/kg (or less); while  
those larger sell for \$5.83/kg (or more); sells summer crop to Japan, and  
winter crop locally; land cost closest to the sea is most expensive at \$100,000/ha.  
further from the sea it is less expensive; also less expensive if the land  
is sinking.

FARM SURVEY SUMMARY SHEET

Farm No. 2 Date Interviewed 9/17/85

Number of years experience by manager more than 6

Number of years farm used to raise shrimp 6

Company operated  Family operated

Number and size of ponds: 5 ponds at 0.3 ha each = 1.5 ha total

Water Depth 1.5 - 2.0

Drain: Center  Side  Corner

Dike: Concrete  Earthen

Bottom: Soil and imported Sand

Water Supply: FW - none; SW - 4 pumps

Total HP: 25

Aeration: 2 aerators/pond

Total HP: 10

Water Salinity: 32 - 35 ppt

Use D.O. meter for oxygen measurement: Yes  No

Cost for electricity: \$0.048/kw-hr; \$3,000/4 mo. crop all ponds.

Aeration Schedule: Small shrimp - nighttime only; large shrimp - 24 hrs/day.

Stocking: Size PL 12-25 Source Commercial nursery

No./m<sup>2</sup> 60

Growout: Season April - December

Average Crop time per crop \_\_\_\_\_

Feed: Cost \_\_\_\_\_ Feed Conversion \_\_\_\_\_

Chemicals: \_\_\_\_\_

How is bottom treated: pump out black sediment from center; soil dry 1 - 2 weeks; lime

Labor: 1 person and wife

Harvest Costs: \$0.042/kg harvested

Size at harvest: 28.5 g

Survival Rate: 60% Price: \$6.25/kg

Total Production last Year: 31,000 kg

Average crops per year: 2

Other costs: Land today

Problems: Water quality; Typhoons; high mortality when water temp 35° C or more; 27-28° C. best.

Comments: Aerators cost \$275. each; ponds would cost \$125,000 to build today.

FARM SURVEY SUMMARY SHEET

Farm No. 1 Date Interviewed 9/17/85  
 Number of years experience by manager 4 - 5  
 Number of years farm used to raise shrimp 1  
 Company operated \_\_\_\_\_ Family operated X  
 Number and size of ponds: 3 ponds: 0.25, 0.25, 0.30 = 0.8 ha total

---

Water Depth 1.5 m to start; increase to 2.0 m  
 Drain: Center X Side \_\_\_\_\_ Corner \_\_\_\_\_  
 Dike: Concrete \_\_\_\_\_ Earthen X  
 Bottom: Soil, no sand, clay soil

---

Water Supply: PW - none; SW - 2 wells with 3.5 HP each; 20 m deep  
 Total HP: 7

---

Aeration: Paddlewheel 2/ponds; also has air diffuser used during 1st  
2 weeks after stocked Total HP: 6

---

Water Salinity: 25 ppt  
 Use D.O. meter for oxygen measurement: Yes \_\_\_\_\_ No X  
 Cost for electricity: \$2,250/yr. for pumps and aerators.

---

Aeration Schedule: Same as farm 2 except will run on cloudy day  
all day.

---

Stocking: Size PL 30-35 Source Commercial Nursery  
 No./m<sup>2</sup> 20

---

Growout: Season April - December (Dry Jan/May)  
 Average Crop time per crop 4 mo.  
 Feed: Cost \$6,250/yr. Feed Conversion 1.86  
 Chemicals: None

---

How is bottom treated: pump out black sediment; sun dry; 100 kg lime/0.1  
ha; also uses "enzymes".

---

Labor: 1 person (owner/operator who was a water supply engineer by  
training).

---

Harvest Costs: \_\_\_\_\_  
 Size at harvest: 28 to 30 g  
 Survival Rate: \_\_\_\_\_ Price: \$6.25/kg  
 Total Production last Year: 2.4 tons for 0.5 ha  
 Average crops per year: 2 crops  
 Other costs: Land today  
 Problems: \_\_\_\_\_

---

Comments: Cost \$1,500 U.S. total to excavate 0.8 ha of ponds; cost  
\$150 U.S. to maintain (re-excavate) during winter; ponds were built by using  
spoils to build up banks; feed costs are about 50% of production costs;  
feed costs are 50.875/kg (\$0.40 U.S./lb) delivered to farm.

FARM SURVEY SUMMARY SHEET

Farm No. 4 Date Interviewed 9/17/85

Number of years experience by manager 2

Number of years farm used to raise shrimp 6

Company operated      Family operated X

Number and size of ponds: 2; 0.2 ha each = 0.4 total

Water Depth 1.5 m max

Drain: Center X Side      Corner     

Dike: Concrete X Earthen     

Bottom: Soil, clay & mud, covered w/sand and gravel

Water Supply: FW one at 7.5 hp; SW one at 3 hp (Direct intake from sea).

Total HP: 10.5

Aeration: Paddlewheels, 3/pond

Total HP: 6

Water Salinity:     

Use D.O. meter for oxygen measurement: Yes      No X

Cost for electricity: 50.05/kw - hr; \$1,250 U.S./yr.

Aeration Schedule:     

Stocking: Size PL5 Source hatchery

No./m<sup>2</sup> 42.5/m<sup>2</sup>

Growout: Season April/May (empty Nov/March)

Average Crop time per crop 4 mo. (105-120 days)

Feed: Cost      Feed Conversion 2.0

Chemicals: lime

How is bottom treated: dried and limed

Labor: wife operates farm, husband works for local government

Harvest Costs:     

Size at harvest: 33 g

Survival Rate: 71% Price: \$5.75 - \$6.88/kg

Total Production last Year: 7,980 kg

Average crops per year: 2

Other costs: Land today \$150,000 to \$200,000/ha w/o construction

Problems: disease; water quality; muddy bottom killed PL's, so

imported sand.

Comments: Can pump water from pond through a charcoal filter and back

to pond, or to second pond; total income = \$50,272/yr; This area is sinking,

already had to raise height of walls.

FARM SURVEY SUMMARY SHEET

Farm No. 5 Date Interviewed 3/18/85  
 Number of years experience by manager 10  
 Number of years farm used to raise shrimp 5  
 Company operated  Family operated   
 Number and size of ponds: 9 ponds; 0.5 to 1.0 ha; total = 7.0 ha  
 (area cited might include dike area)  
 Water Depth 1.2 m  
 Drain: Center  Side  Corner   
 Dike: Concrete  Earthen   
 Bottom: Soil  
 Water Supply: FW one well, 10 HP; SW 4 motors 10 HP  
 Total HP: 20  
 Aeration: Paddlewheels  
 Total HP: 14  
 Water Salinity: \_\_\_\_\_  
 Use D.O. meter for oxygen measurement: Yes  No   
 Cost for electricity: \$0.054/kw/hr., \$9,000/yr.  
 Aeration Schedule: \_\_\_\_\_  
 Stocking: Size PL45 Source Commercial Nursery  
 No./m<sup>2</sup> 30-35/m<sup>2</sup>  
 Growout: Season All year  
 Average Crop time per crop 4 mo. summer; 6 mo. winter  
 Feed: Cost \_\_\_\_\_ Feed Conversion \_\_\_\_\_  
 Chemicals: \_\_\_\_\_  
 How is bottom treated: \_\_\_\_\_  
 Labor: 1 manager; 2 laborers @ \$300/mo. each  
 Harvest Costs: \_\_\_\_\_  
 Size at harvest: 30-35 g  
 Survival Rate: \_\_\_\_\_ Price: (S) \$5.83/kg; (W) \$6.67/kg  
 Total Production last Year: \_\_\_\_\_  
 Average crops per year: \_\_\_\_\_  
 Other costs: Land today \_\_\_\_\_  
 Problems: disease; water quality  
 Comments: Cost \$1,250/ha for excavation during pond construction

FARM SURVEY SUMMARY SHEET

Farm No. 6 Date Interviewed 9/19/85  
 Number of years experience by manager 13  
 Number of years farm used to raise shrimp 13  
 Company operated  Family operated   
 Number and size of ponds: 12 ponds; total = 3.5 ha.

Water Depth 1.2 m  
 Drain: Center  Side  Corner   
 Dike: Concrete  Earthen   
 Bottom: Soil, mud/clay  
 Water Supply: FW - 4 wells @ 10 hp each, 150 m deep; SW - 4 pumps @ 5 hp  
 Total HP: 60  
 Aeration: 25 paddlewheels; 8 @ 2 hp, 17 @ 1 hp  
 Total HP: 35

Water Salinity: \_\_\_\_\_  
 Use D.O. meter for oxygen measurement: Yes  No   
 Cost for electricity: \_\_\_\_\_

Aeration Schedule: 1st 45 days - no aeration; days 45 - 60 night only;  
60 - 120 days continuous  
 Stocking: Size PL25 Source nursery  
 No./m<sup>2</sup> 32/m<sup>2</sup> - 19./m<sup>2</sup>  
 Growout: Season \_\_\_\_\_  
 Average Crop time per crop \_\_\_\_\_  
 Feed: Cost \$0.825/kg Feed Conversion 1.9  
 Chemicals: \_\_\_\_\_  
 How is bottom treated: \_\_\_\_\_

Labor: 2 managerial staff, 2 laborers  
 Harvest Costs: \_\_\_\_\_  
 Size at harvest: 35.5 g  
 Survival Rate: \_\_\_\_\_ Price: \$6.05/kg  
 Total Production last Year: \_\_\_\_\_  
 Average crops per year: 2  
 Other costs: Land today This farm had just sold for \$342,000 U.S.  
 Problems: land sinking at 20 cm/yr; also have red color shrimp

Comments: uses pH to measure water quality and exchanges water to control  
pH; pH 7.8 for days 0-45; pH 8.0 for days 45 on; land that is not sinking  
will sell for \$112,500/ha. Production Costs: PL (32.5%); Feed (50%);  
Electricity (10%); Other (8%). Labor costs for one crop on 0.85 ha = \$1,500;  
PL cost \$41.25/1,000.

FARM SURVEY SUMMARY SHEET

Farm No. 7 Date Interviewed 9/19/85

Number of years experience by manager \_\_\_\_\_

Number of years farm used to raise shrimp 4 (30 yrs old)

Company operated \_\_\_\_\_ Family operated \_\_\_\_\_

Number and size of ponds: 6; 3.5 ha total.

Water Depth \_\_\_\_\_

Drain: Center \_\_\_\_\_ Side \_\_\_\_\_ Corner X

Dike: Concrete X Earthen X

Bottom: Soil, natural

Water Supply: FW wells, 3 pumps @ 2.5 HP; SW - 5 wells (HP unknown)  
and from canal w/o pumping Total HP: N/A

Aeration: Paddlewheels - 24  
 Total HP: 48

Water Salinity: \_\_\_\_\_

Use D.O. meter for oxygen measurement: Yes \_\_\_\_\_ No X

Cost for electricity: \$10,000/yr.

Aeration Schedule: Depends on weather, temperature, and looks of water.

Stocking: Size PL 20-25 Source Commercial nursery

No./a<sup>2</sup> 40/m<sup>2</sup>

Growout: Season \_\_\_\_\_

Average Crop time per crop \_\_\_\_\_

Feed: Cost \_\_\_\_\_ Feed Conversion \_\_\_\_\_

Chemicals: lime

How is bottom treated: Sun dry then add lime

Labor: 2 managers (brothers); part-time labor 7 to 10 man-days/mo.  
@ \$13.75/day.

Harvest Costs: \_\_\_\_\_

Size at harvest: 30-35 g

Survival Rate: 83% Price: \_\_\_\_\_

Total Production last Year: shrimp 7,560 kg, plus milkfish

Average crops per year: \_\_\_\_\_

Other costs: Land today \_\_\_\_\_

Problems: No problems, always make profit

Comments: Raised only milkfish until 4 yrs ago, now 2 crops shrimp

(Nov/Apr), milkfish (Sept 1 - Nov 30). Sell milkfish to tuna fishermen.

milkfish feed cost \$0.36/kg, shrimp feed cost \$0.88/kg.



FARM SURVEY SUMMARY SHEET

Farm No. 8 Date Interviewed 9/20/87

Number of years experience by manager 5

Number of years farm used to raise shrimp 3 1/2 shrimp

Company operated X Family operated X

Number and size of ponds: 11 ponds, 4.5 ha total

Water Depth 1.5 m

Drain: Center      Side X Corner X

Dike: Concrete X Earthen     

Bottom: Soil, natural

Water Supply: river; don't have ability to control salinity;

5 wells @ 7.5 hp Total HP: 37.5

Aeration: 40 paddlewheels, 1 & 2 hp

Total HP: 53

Water Salinity: 5 ppt when we were there, 20 ppt at times

Use D.O. meter for oxygen measurement: Yes      No X

Cost for electricity: \$10,000/yr.

Aeration Schedule:     

Stocking: Size PL 20-25 Source Commercial nursery

No./m<sup>2</sup> About 20/m<sup>2</sup>

Growout: Season 12 mo.

Average Crop time per crop     

Feed: Cost      Feed Conversion     

Chemicals:     

How is bottom treated: Contractual: 2 people/1 day/ 0.25 ha pond

@ \$31.25/person: pump out sediment; sundry; lime

Labor: 1 manager (wife); 4 laborers @ \$12.50/person/day

Harvest Costs:     

Size at harvest: 30 g

Survival Rate:      Price:     

Total Production last Year: 10 tons/ha

Average crops per year: 2.5

Other costs: Land today     

Problems: Water supply, can't control salinity, too low in rainy season;

disease (red color)

Comments: Feeds 20% trash fish by total feed cost (trash fish \$0.225/kg);

had back up generator (diesel), 60 HP which could run 48 HP worth of motor

(Cost \$10,000). This farm was located on a river. When it rained a lot,

there was much freshwater outflow and the salinity at the farm was too low.

During dry season, seawater flowed upriver to the farm.

FARM SURVEY SUMMARY SHEET

Farm No. 9 Date Interviewed 9/20/85

Number of years experience by manager 10

Number of years farm used to raise shrimp 40

Company operated      Family operated X

Number and size of ponds: 6; total 5.4 ha, largest pond 1/2 ha.

Water Depth 2 m by harvest time

Drain: Center      Side      Corner X

Dike: Concrete X Earthen     

Bottom: Soil, mud, natural

Water Supply: FW - 2 wells, 12 hp; SW - canal, gravity flow

Total HP: 12

Aeration: 32 paddlewheels

Total HP: 32

Water Salinity:     

Use D.O. meter for oxygen measurement: Yes X No     

Cost for electricity: \$7,500/yr.

Aeration Schedule: Depends on size, weather, etc; but uses 1

paddlewheel per 35,000 shrimp

Stocking: Size PL 20 Source     

No./m<sup>2</sup> 20/m<sup>2</sup>

Growout: Season mid February - November

Average Crop time per crop     

Feed: Cost \$62,400/yr. Feed Conversion 1.4

Chemicals:     

How is bottom treated:     

Labor: Owner plus wife; plus hire 1 part-time for 10 days/mo @ \$12.50/day

Harvest Costs:     

Size at harvest: 33-35 g

Survival Rate: 70% Price:     

Total Production last Year: 9,000 kg/ha

Average crops per year: 2

Other costs: Land today     

Problems: no problems

Comments:

FARM SURVEY SUMMARY SHEET

Farm No. 10 Date Interviewed 5/21/85  
 Number of years experience by manager 24  
 Number of years farm used to raise shrimp 50  
 Company operated \_\_\_\_\_ Family operated \_\_\_\_\_  
 Number and size of ponds: 9 ponds: 0.3 to 4.0 ha: 14 ha total, plus  
4 nursery ponds 0.2 ha total  
 Water Depth \_\_\_\_\_  
 Drain: Center \_\_\_\_\_ Side X Corner \_\_\_\_\_  
 Dike: Concrete X Earthen X  
 Bottom: Soil, natural  
 Water Supply: FW 1 well 25 m deep, 10 hp; SW 10 wells @ 30 ppt,  
10 m deep 40 hp Total HP: 50  
 Aeration: 59 paddlewheels  
 Total HP: 59  
 Water Salinity: \_\_\_\_\_  
 Use D.O. meter for oxygen measurement: Yes \_\_\_\_\_ No X  
 Cost for electricity: \$2,500/mo.  
 Aeration Schedule: \_\_\_\_\_  
 Stocking: Size PL 30 Source \_\_\_\_\_  
 No./m<sup>2</sup> 25/m<sup>2</sup>  
 Growout: Season Feb 1 - Nov 30  
 Average Crop time per crop \_\_\_\_\_  
 Feed: Cost \_\_\_\_\_ Feed Conversion 1.5/2.0  
 Chemicals: \_\_\_\_\_  
 How is bottom treated: Sun dry and lime  
 Labor: 3 family members, plus 2 part-time laborers @ \$15/day when harvest  
 Harvest Costs: \_\_\_\_\_  
 Size at harvest: 30 g  
 Survival Rate: 80% Price: \_\_\_\_\_  
 Total Production last Year: 12,000 kg/yr.  
 Average crops per year: 2  
 Other costs: Land today \_\_\_\_\_  
 Problems: Disease (red color)  
 Comments: Oldest farm in this area; used to raise milkfish; has  
80 hp emergency generator.

FARM SURVEY SUMMARY SHEET

Farm No. 11 Date Interviewed 9/21/85

Number of years experience by manager 15

Number of years farm used to raise shrimp 10

Company operated \_\_\_\_\_ Family operated X

Number and size of ponds: 3 ponds, 1.3 ha total; 6 nursery ponds  
0.2 ha total

Water Depth 1.0 - 2.0 (0.5 m when first stocked)

Drain: Center \_\_\_\_\_ Side \_\_\_\_\_ Corner X

Dike: Concrete X Earthen X

Bottom: Soil

Water Supply: PN 4 @ 3 hp; SW 4 @ 3 hp

Total HP: 24

Aeration: 9 paddlewheels

Total HP: 18

Water Salinity: 20 - 30 ppt

Use D.O. meter for oxygen measurement: Yes \_\_\_\_\_ No X

Cost for electricity: \_\_\_\_\_

Aeration Schedule: \_\_\_\_\_

Stocking: Size \_\_\_\_\_ Source \_\_\_\_\_

No./m<sup>2</sup> \_\_\_\_\_

Growout: Season 8 mo/yr

Average Crop time per crop \_\_\_\_\_

Feed: Cost \_\_\_\_\_ Feed Conversion 1.5 - 2.2

Chemicals: \_\_\_\_\_

How is bottom treated: Sun dry only

Labor: Owner plus wife

Harvest Costs: \_\_\_\_\_

Size at harvest: 25 to 35 g

Survival Rate: \_\_\_\_\_ Price: \_\_\_\_\_

Total Production last Year: \_\_\_\_\_

Average crops per year: 2

Other costs: Land today \_\_\_\_\_

Problems: none

Comments: \_\_\_\_\_

## **Appendix B. Description of Reinforced Concrete Pond Walls in Taiwan**

The intent of this appendix is to describe concrete pond walls observed at shrimp farms in Taiwan and to make cost estimates for construction of these walls in the United States. Of the 11 farms visited, eight had concrete walls and three had soil banks. Of the eight with concrete walls, each was slightly or totally different from the others, reflecting the individuality of the designers and builders. This description includes walls at five farms described in the survey summaries (Appendix A) and one farm inspected during its construction.

### **Farm 1**

The newer concrete walls at farm 1 were 6 years old, and the ponds were more representative of the newer designs (Figures B-1 and B-2; farm 1, Appendix A). The walls rested on 7.6-cm pilings and had a footing below the pond bottom measuring 0.8 x 1.0 m. The wall was reinforced internally with an iron reinforcing rod (re-bar) but did not have buttresses on the outside. The top had a walkway measuring 50 to 80 cm. The wall was tapered from 20.3 cm thick near the base to 15.2 cm thick at the walkway.

Also, farm 1 had an earlier design which had a water canal on the top and buttresses on the side of the walls (Figure B-3). Cross-sectional sketches of this design were not obtained.

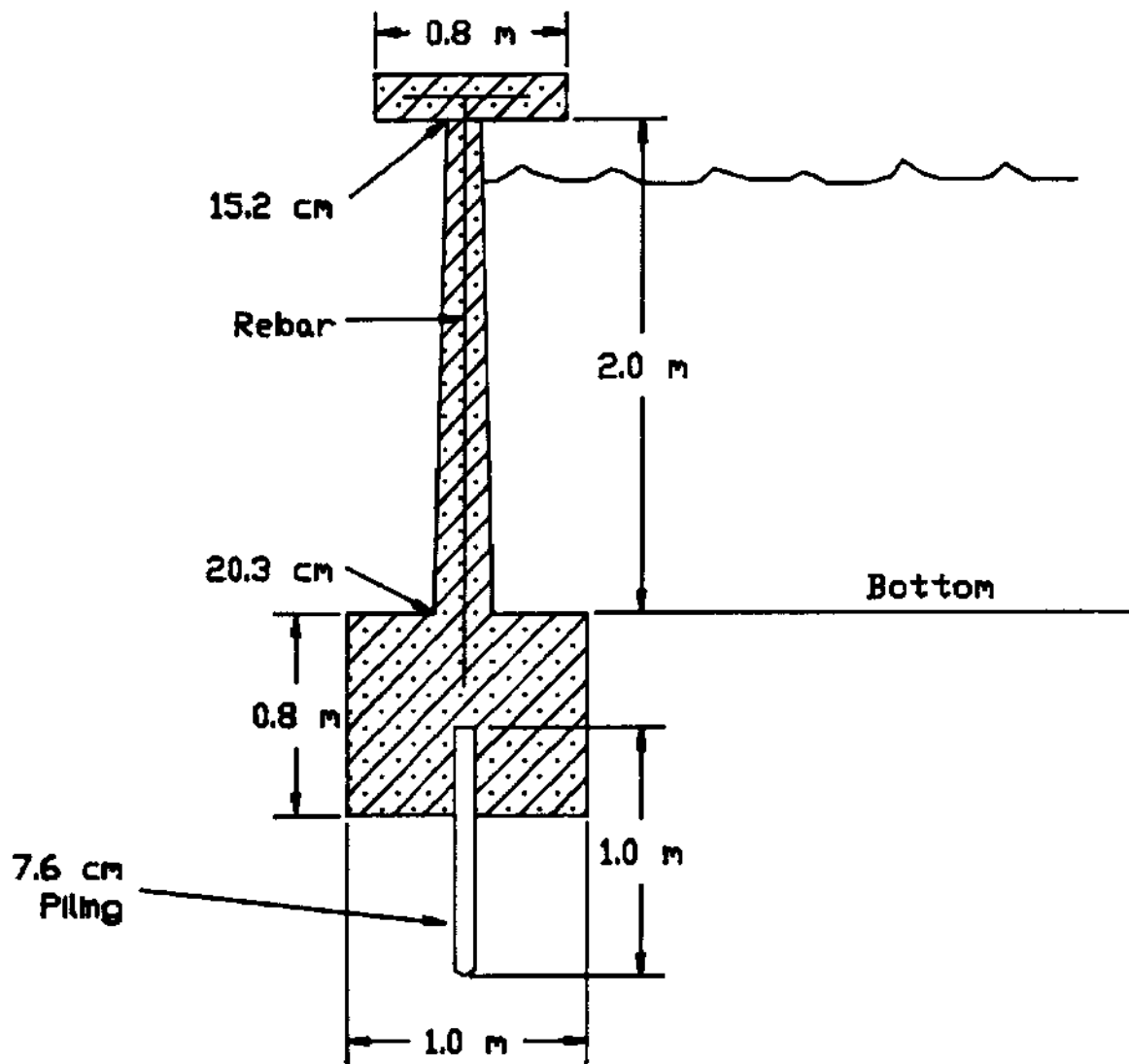
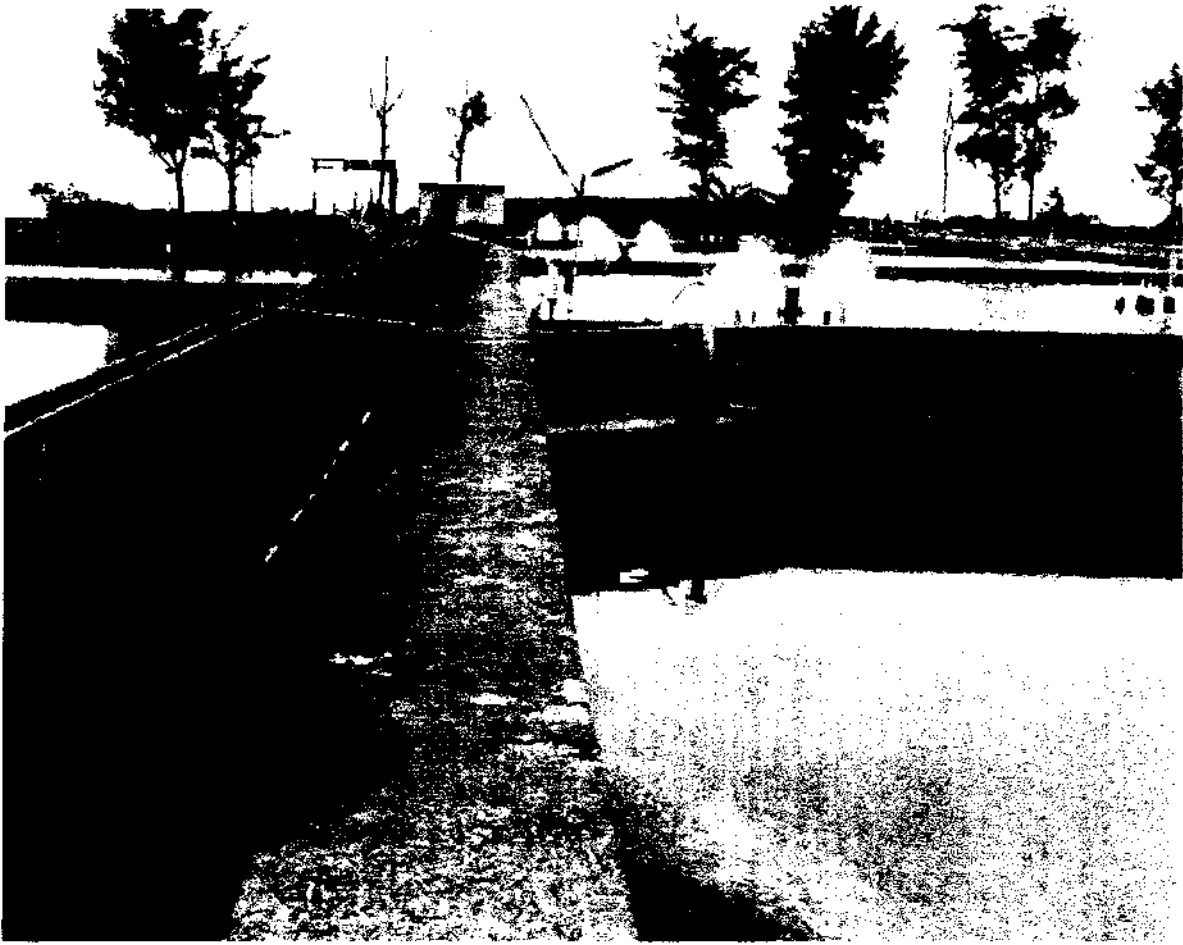

Figure B-1. Cross-section of reinforced concrete pond wall at farm 1.



*Figure B-2. Concrete-walled ponds at farm 1, facing the ocean. The central drainage canal separates the older ponds on the left from the newer ponds on the right. A seawater supply pipe is in the drainage canal, and a supply canal is on the top of older pond wall (left).*



*Figure B-3. Concrete-walled ponds at farm 1, away from the ocean. The central drainage canal separates the older ponds on the right from the newer ponds on the left. Seawater supply pipes are in the drain canal, and a water supply canal is on top of the older pond walls.*



Farm 2

The concrete pond walls at farm 2 were buttressed (Figures B-4 and B-5). The buttresses were 10 m apart on alternating sides of the wall and increased in width from the crown of the wall to 0.6 m at the base, 1 m below the pond bottom. The wall increased in thickness from 15.2 cm just below the crown to 0.5 m at the base.

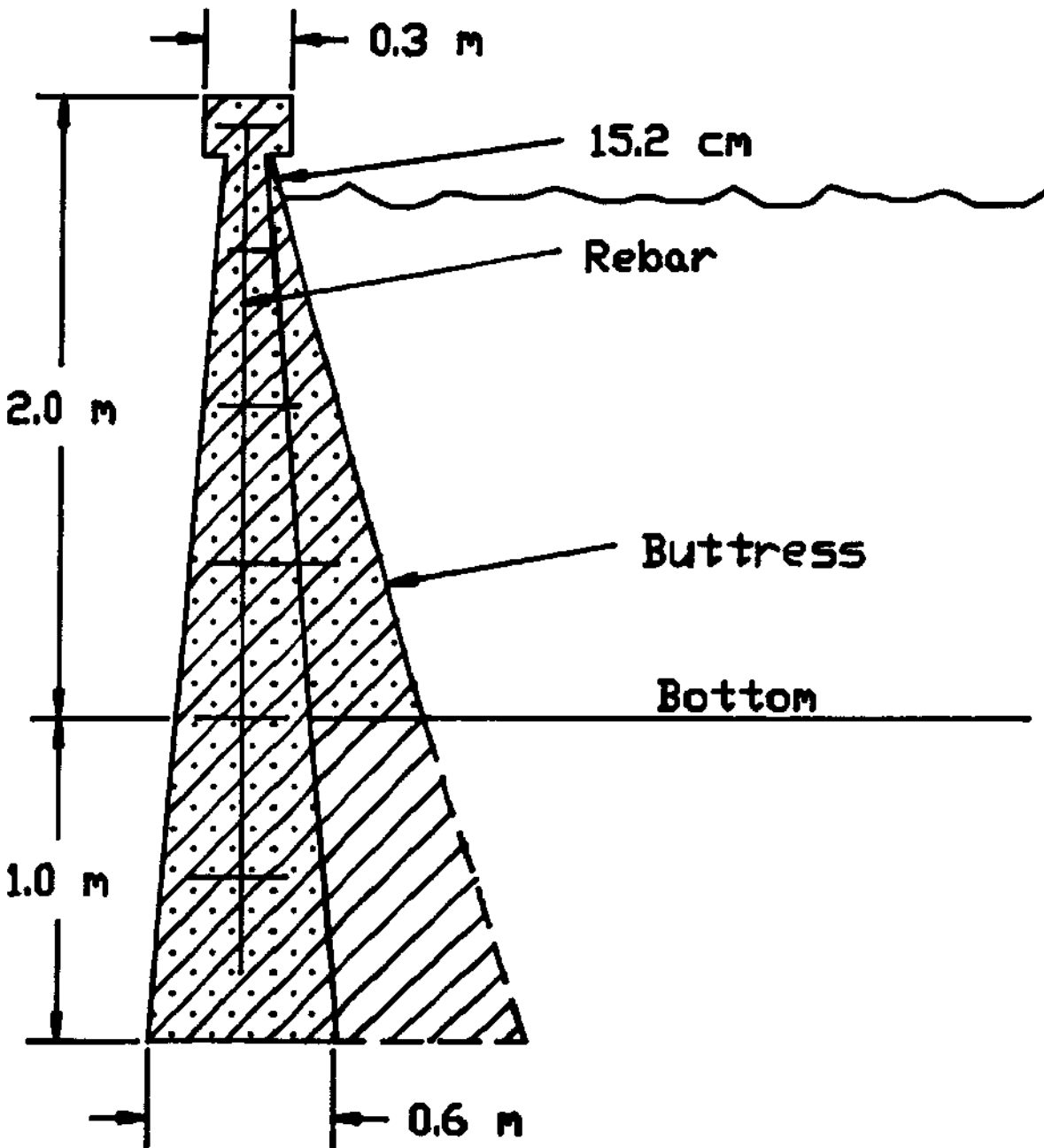

Figure B-4. Cross-section of reinforced concrete wall at farm 2.



*Figure B-5. Concrete-walled ponds at farm 2. Two 1 hp paddlewheel aerators are seen resting on the dried bottom.*

## Farm 6

The concrete pond walls at farm 6 were similar to those at farm 1, except that the walls at farm 6 did not have pilings, the walls were not as high, and the re-bar reinforcement in the walls were "double layered" rather than "single layered" (Figures B-6 and B-7). The owner of farm 6 said the builders could set up to 150 m of wall per day.

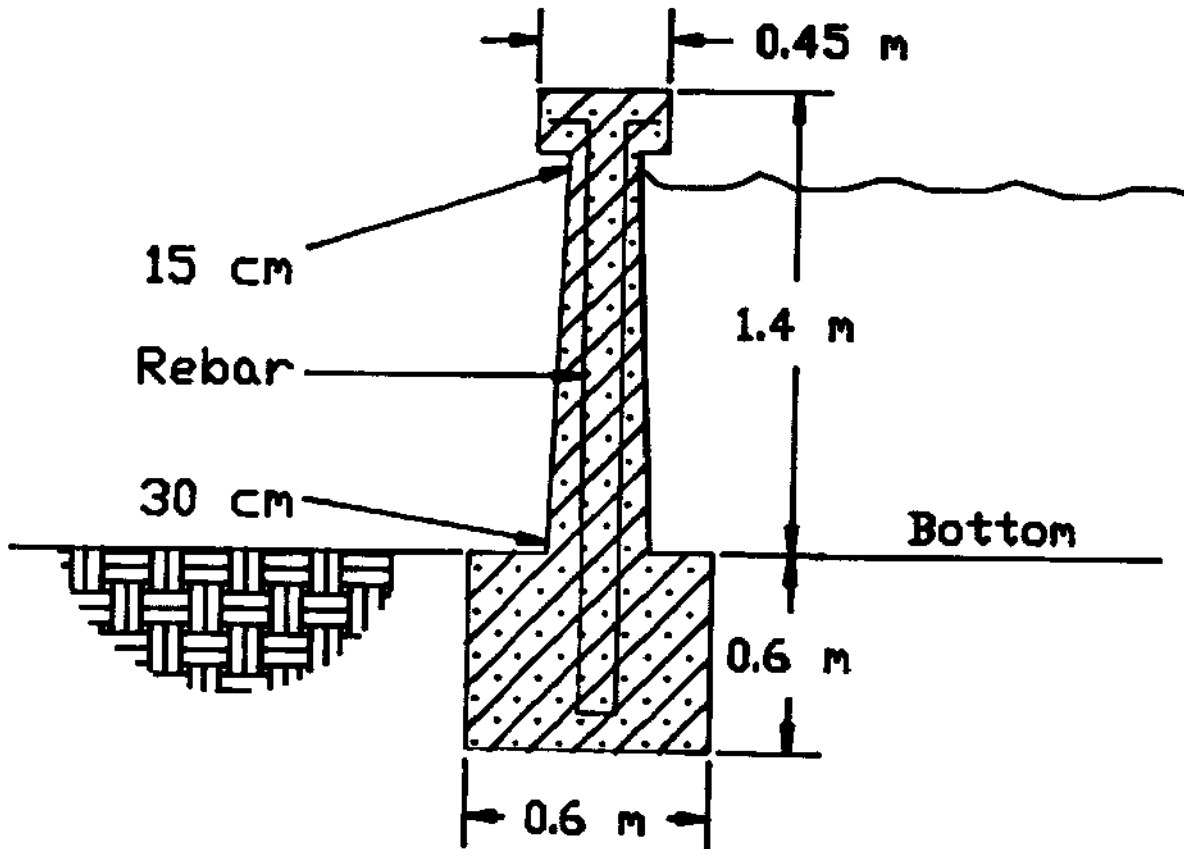
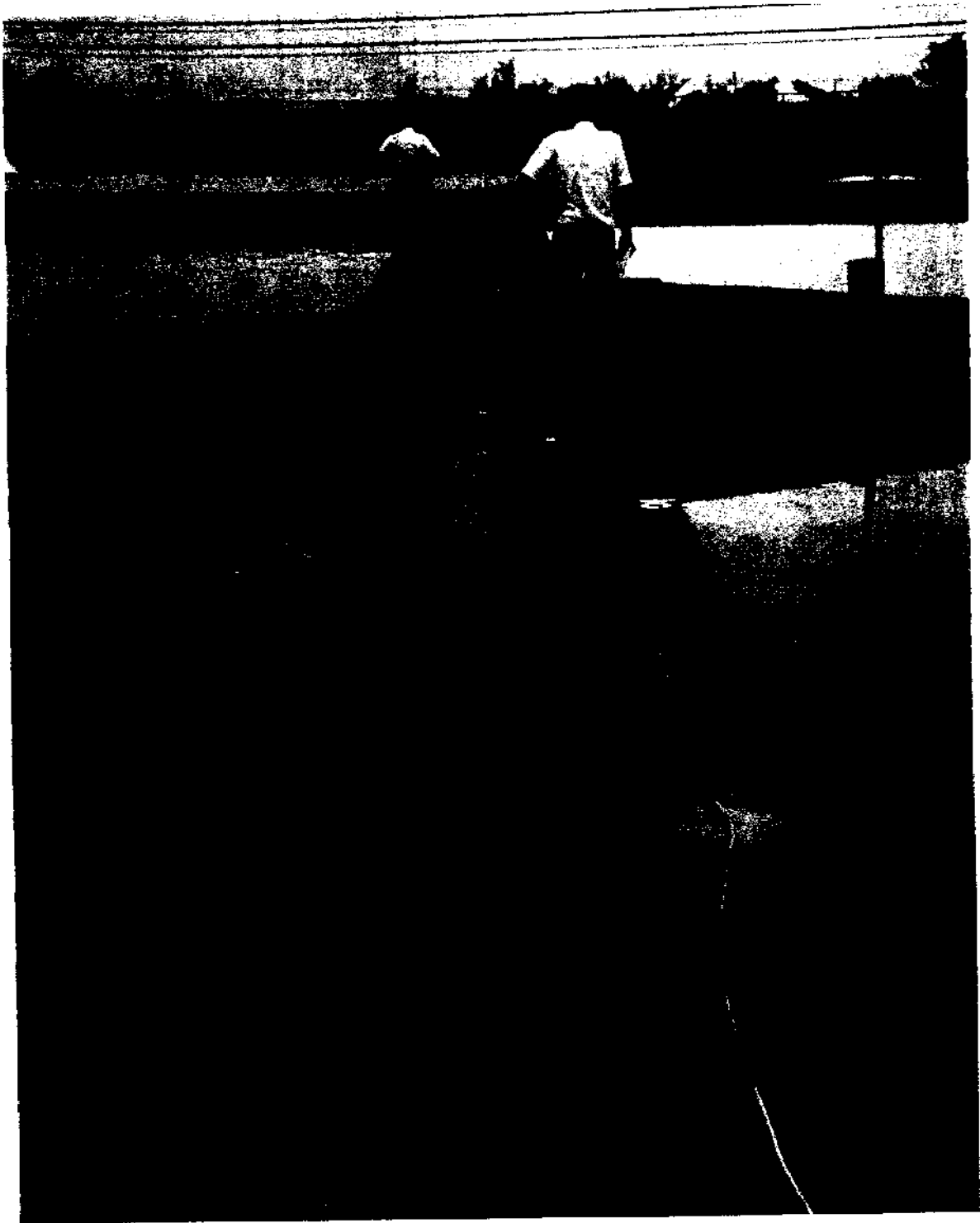

Figure B-6. Cross-section of reinforced concrete wall at farm 6.



*Figure B-7. Concrete-walled ponds at farm 6. A drainage canal separates the ponds.*

## Farm 9

The concrete walls at farm 6 had a variety of style, reflecting the 40-year age of the farm (farm 9, Appendix A). The walls on the newer ponds had bamboo pilings, 1.5 m long. The pilings extended into the footing, as well as into the underlying soil (Figures B-8 and B-9). The walls were 2 m high, with a 0.7 x 1.0-m footing and 0.9-m wide walkway at the top. The walls also had buttresses that extended from the walkway to the footing.

Another wall design at farm 9 contained a water distribution canal built into the top, along with a walkway (Figure B-10). Pipes extending through the canal wall were capped with crimped, slip-on cap pipes to control water flow into the pond.

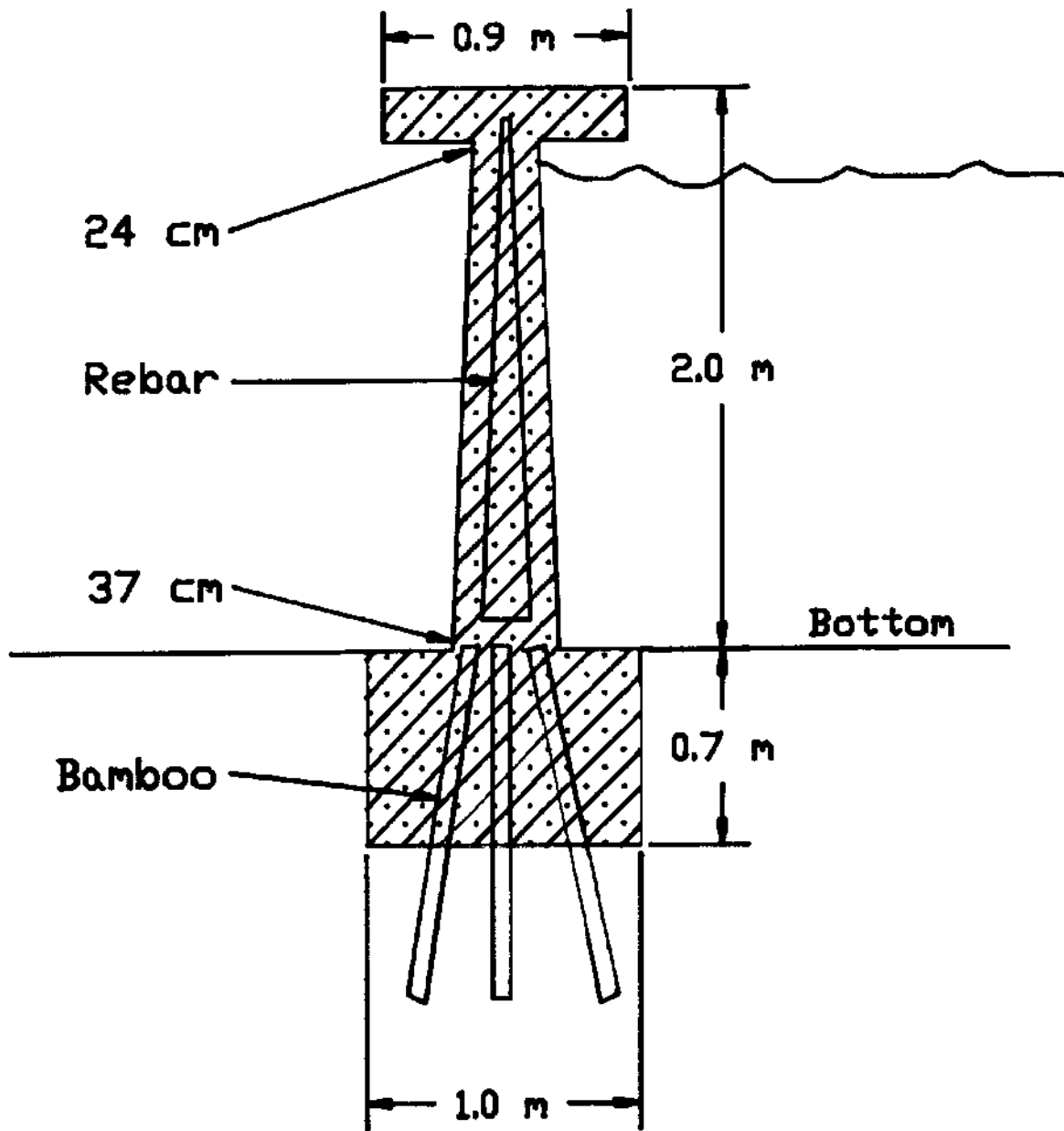

Figure B-8. Cross-section of reinforced pond wall at farm 9.



*Figure B-9. Concrete-walled ponds at farm 9.*



*Figure B-10. Concrete wall at farm 9 with built-in water supply canal on top.*



## Farm 10

The pond walls at farm 10 were some of the oldest observed during the survey. They contained large rocks, but no re-bar and a water canal made of brick at the top of the wall (Figure B-11). The walls extended 0.5 m below the pond bottom and were 0.6 m wide at the bottom of the wall. Some of the walls at this farm had a double water canal and buttresses made of stone on the walls' outer side (Figure B-12).

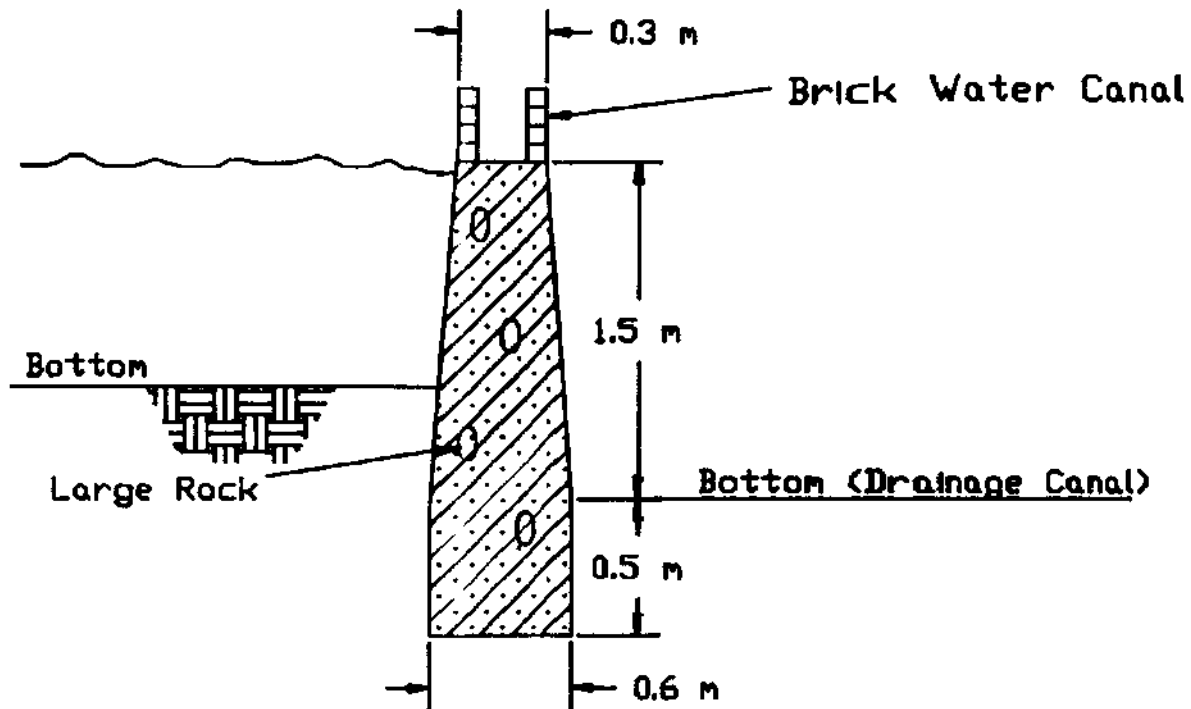
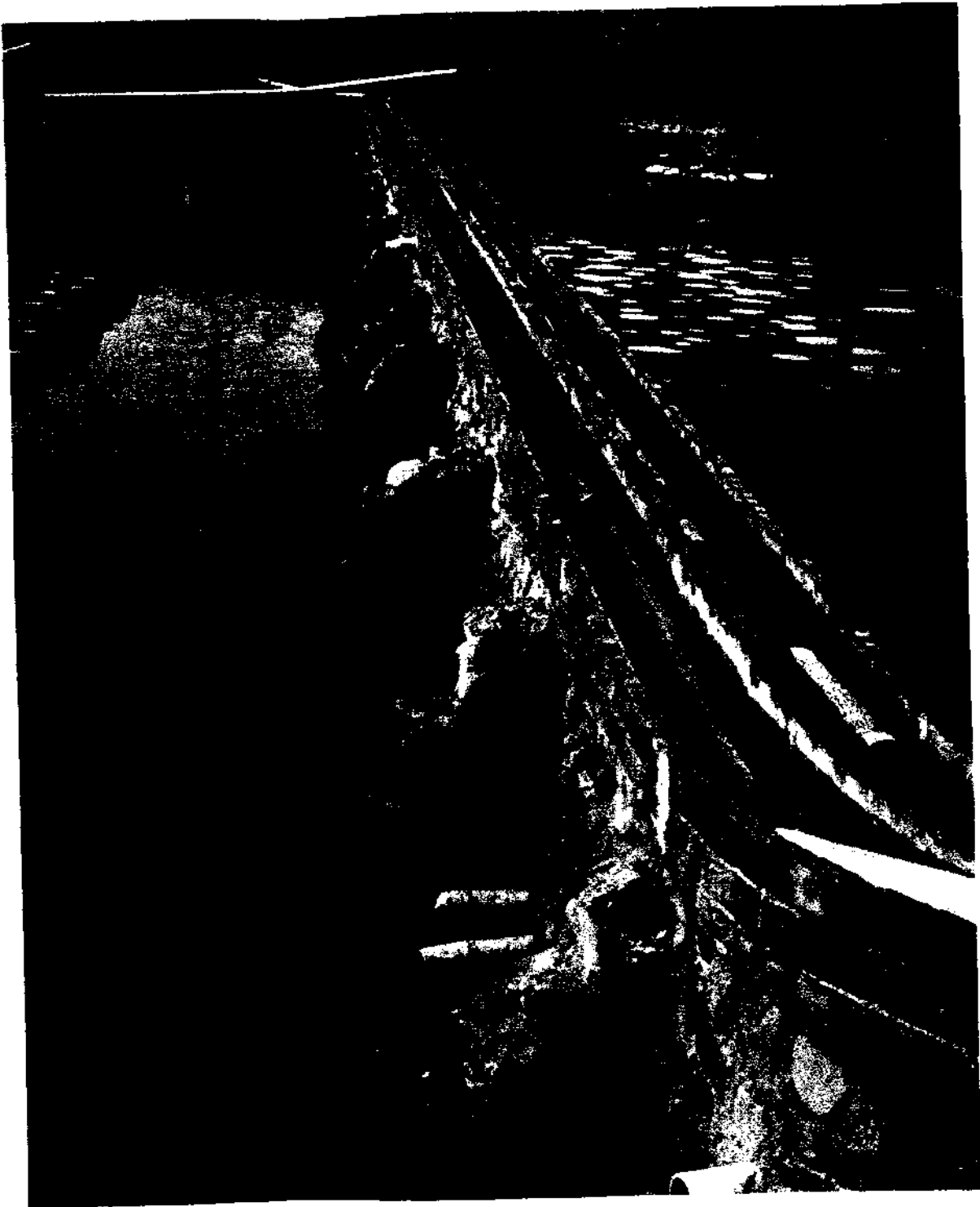

Figure B-11. Cross-section of concrete walls at farm 10. Wall contains large rocks, but no iron reinforcement. Water canal is on top of wall.



*Figure B-12. Concrete and brick pond wall at farm 10. A double water supply canal can be seen atop this old style wall.*

## Farm 11

The concrete walls at farm 11 were built on the sloped bank of the pond, with a 1.0 x 1.2-m footing at the base of the wall (Figures B-13 and B-14). A vertical brick portion was at the top of the sloped wall. This is the only wall of this design observed.

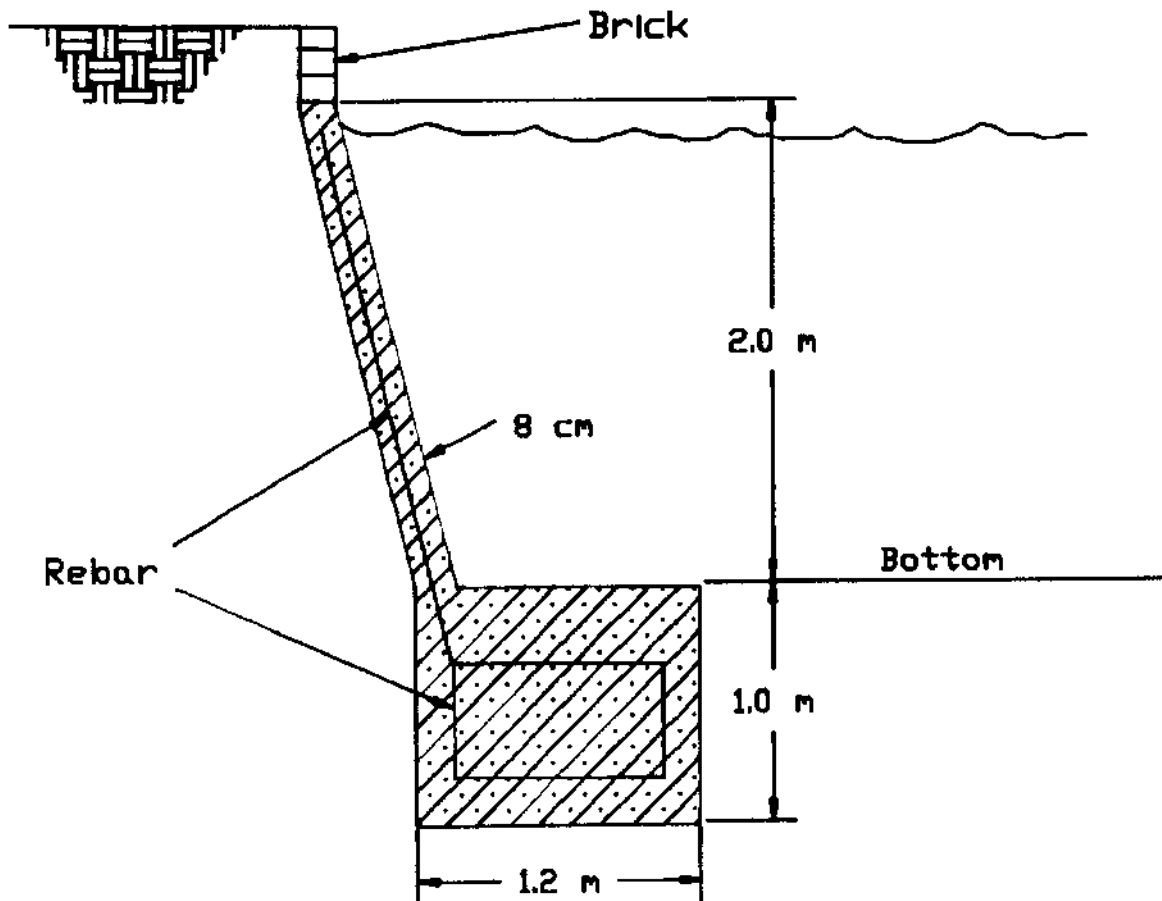
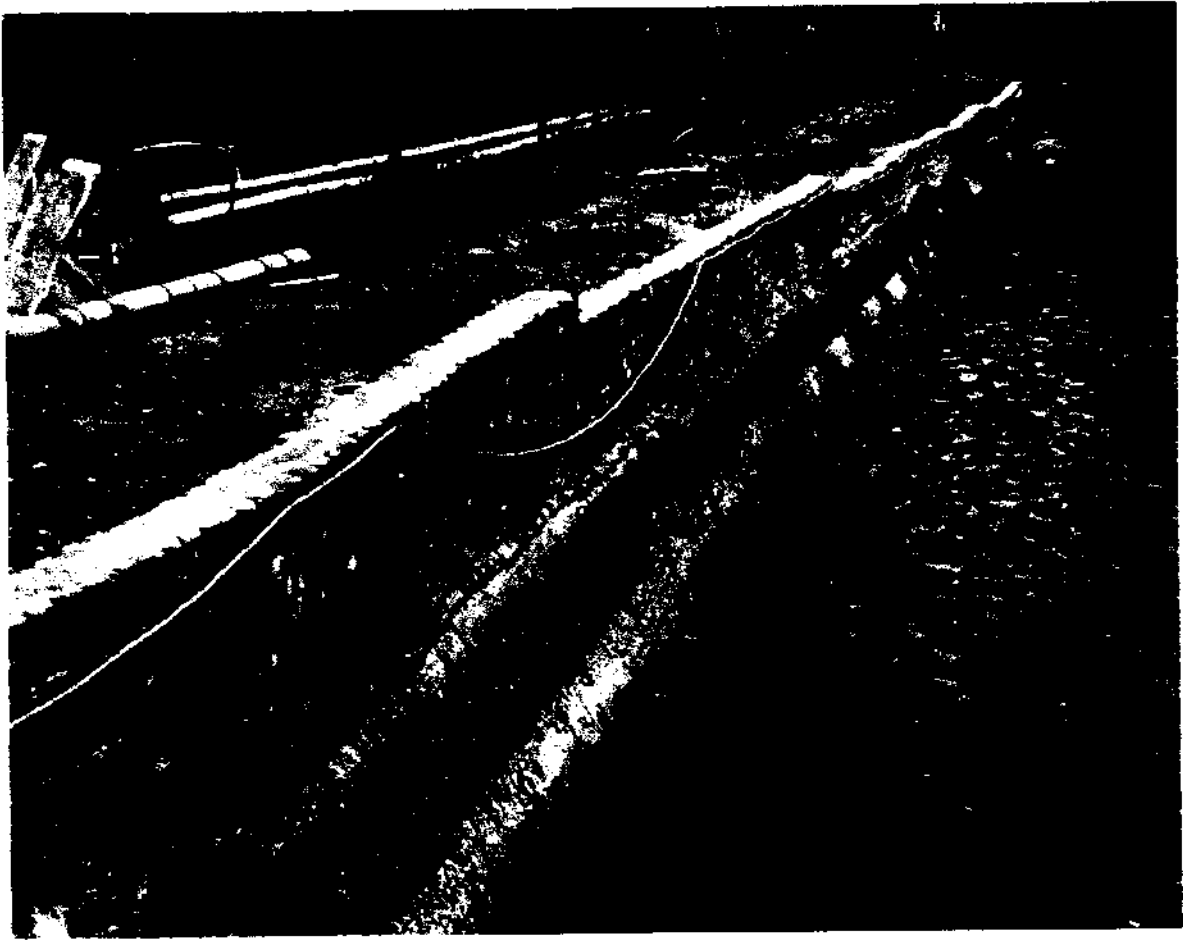

Figure B-13. Cross-section of reinforced sloped concrete pond wall at farm 11.



*Figure B-14. Brick wall at farm 11. The lower portion of the wall covers a sloped earthen dike and is plastered with cement. The upper, vertical portion of the wall was added later when the pond was deepened.*

## New Farm

A new farm under construction near the Tungkang Marine Laboratory was observed, although the owners and builders were not interviewed. The farm contained six square ponds, each measuring 45 m x 45 m (2,025 m<sup>2</sup>). The walls were 2.5 m high from the top of the footing to the top of the walkway (Figures B-15, B-16, and B-17). The footing measured 0.6 m x 0.6 m, and the walkway was 1 m wide. The pattern of re-bar within the walls is unknown. The outer wall was reinforced with buttresses 33 cm wide on 3.4-m intervals (Figure B-18). Water entered each pond along the outer wall and flowed to the inner, common wall where it was discharged into a covered drainage canal (Figures B-19, B-20, and B-21).

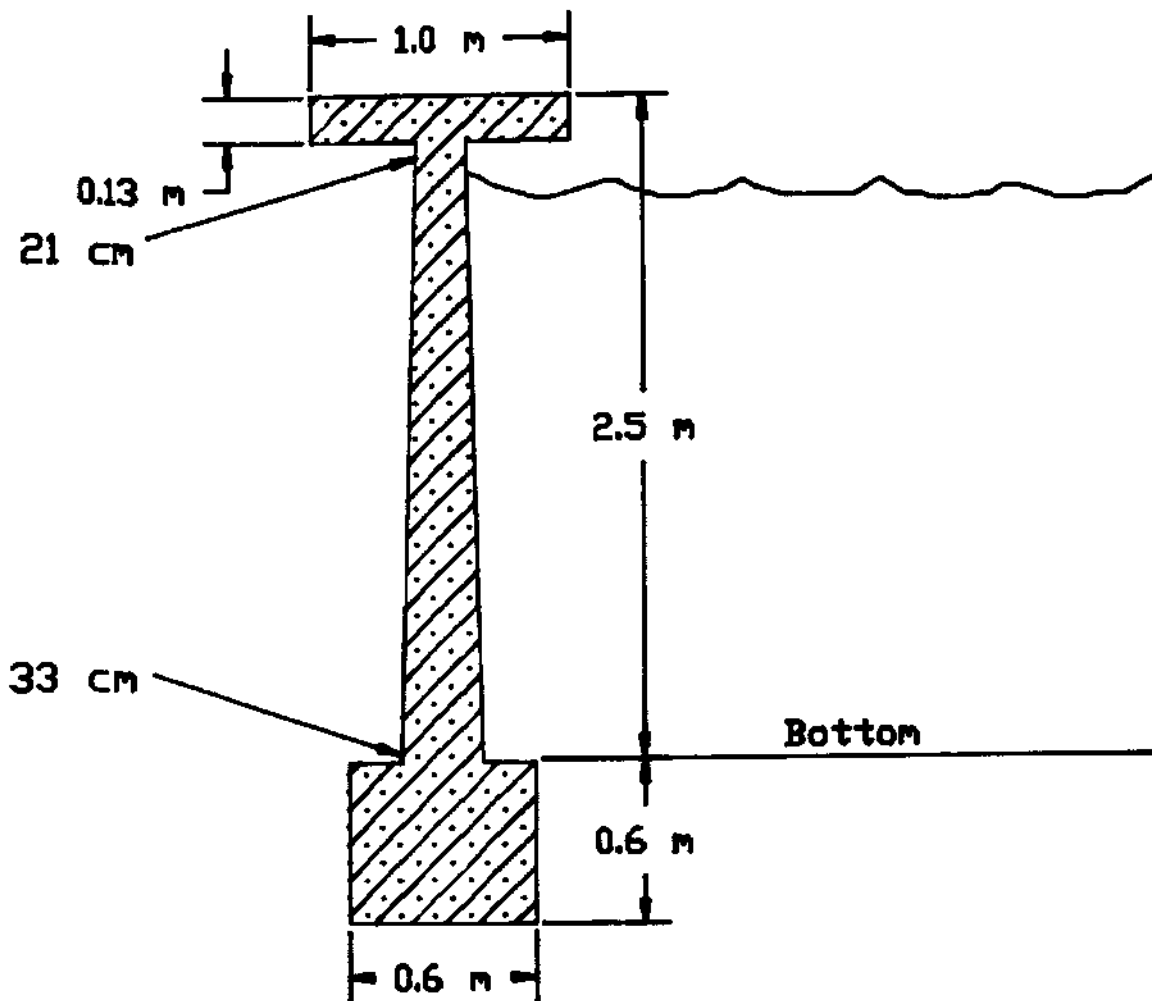
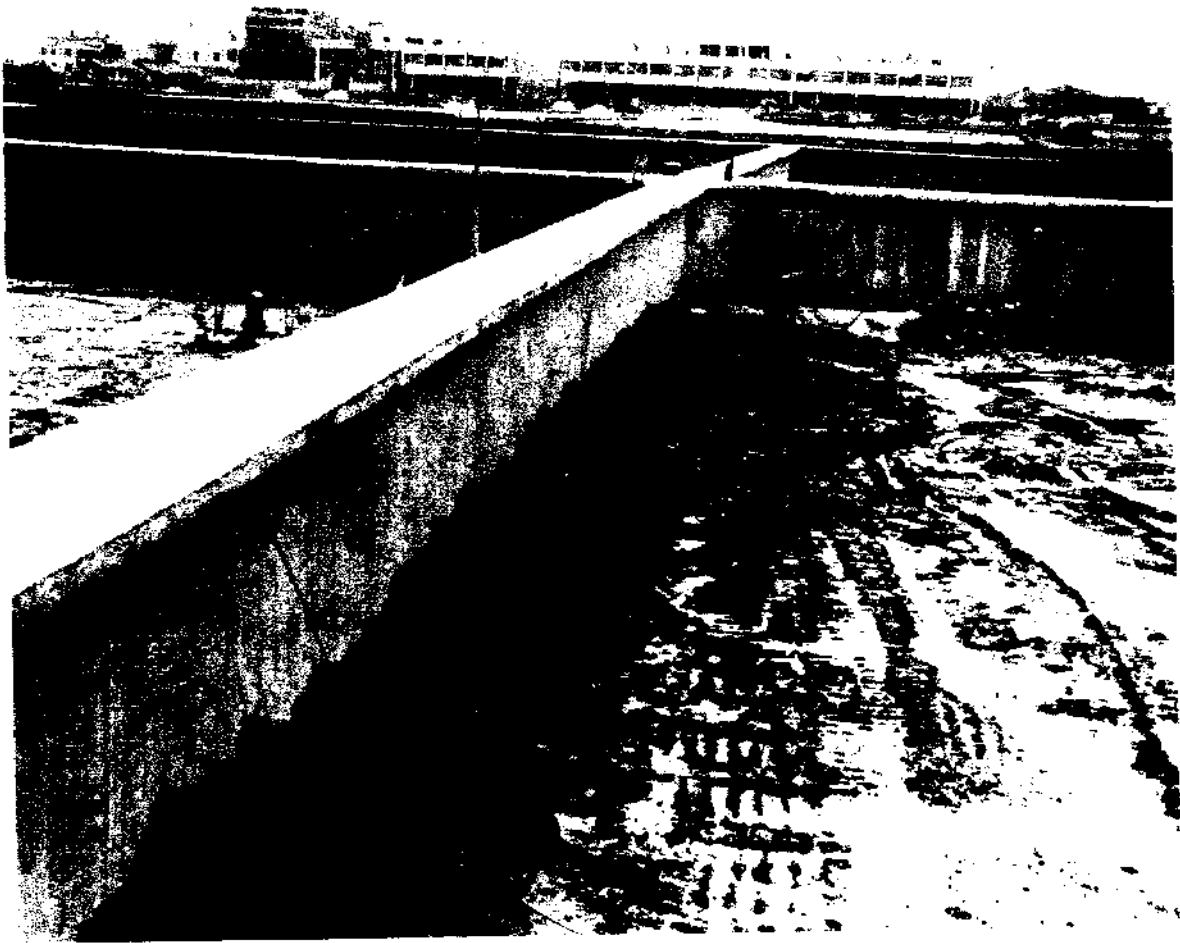

Figure B-15. Cross-section of reinforced concrete pond wall at farm under construction near Tungkang Marine Laboratory. The pattern of re-bar reinforcement is not known. The walls are buttressed on the outside at 3.4 m intervals.



*Figure B-16. A concrete-walled pond under construction.*



*Figure B-17. A concrete-walled pond under construction.*



*Figure B-18. Outer walls of a concrete-walled pond under construction. Old earthen ponds can be seen on the left.*





*Figure B-19. Outlet pipes on a pond under construction near Tungkang.*



*Figure B-20. Concrete walkway and central drainage canals between two rows of newly constructed, concrete-walled ponds.*



*Figure B-21. Central drainage canal between two rows of new concrete-walled ponds. The ceiling of the canal forms the walkway shown in Figure B-20.*

## Wall Costs in the U.S.

Based on the design information obtained during the survey and on cost-estimating procedures described by Hornung (1986), the cost per linear meter to construct in the United States each of the wall designs described was estimated. Costs range from a low of \$196/m for the design at farm 6 to \$475/m for the design at farm 11 (Table B-1). The average cost is \$314/m. The new farm design was below the average cost at \$288/m. In all cases, the major cost is the concrete work.

TABLE B-1. COMPARISON OF INSTALLATION COSTS FOR TAIWAN FACILITIES USING 1985 U.S. COSTS

Farm	Excavation Costs <sup>a</sup>	Concrete Work <sup>b</sup>	Brickwork Costs <sup>c</sup>	Misc. Costs <sup>d</sup>	Design Costs <sup>e</sup>	Total Costs
1	6	285	0	5	15	311
2	5	225	0	5	12	247
6	3	179	0	5	9	196
9	5	334	0	5	17	361
10	3	275	27	5	16	326
11	8	412	27	5	23	475
New	3	266	0	5	14	288

Source: Hornung 1986

Note: All costs listed are in U.S. dollars per lineal meter.

<sup>a</sup>Bulldozer, operator, rental, and labor (\$4/m<sup>3</sup>)

<sup>b</sup>Forms, reinforcing, hoist equipment, concrete materials, and labor (\$230/m<sup>3</sup>)

<sup>c</sup>Bricks, mortar, labor, and overhead (\$45.3/m<sup>2</sup>)

<sup>d</sup>Other materials (pipe, bamboo, etc.) and unforeseen costs (\$5/meter)

<sup>e</sup>5% of estimated installation costs

The construction costs for each wall design in Taiwan are not known, although they apparently are much less than the estimates for construction in the United States. Labor, materials, and energy costs in Taiwan are substantially less than in the United States, which should result in much lower construction costs in Taiwan.

## Appendix C. Operational Schedule and Costs for Aeration and Water Pumping in Taiwan

### Aeration

**Sizing.** For the farms surveyed, the average aerator horsepower ranged from 2.0 to 20.0 hp/ha, with an average of 10.0. For the economic analysis, 12 hp/ha was used. In a 1/4-ha concrete pond, this would mean one 1 hp aerator and one 2-hp aerator were assumed. In a 1/2-ha earthen pond, twice as many aerators of the same sizes were assumed. With quantity imports to the United States during 1985, purchase costs of \$400 for 1 hp units and \$500 for 2-hp units were assumed. A 4-year life expectancy, with \$75/year/unit maintenance cost to replace motors, impellers, gear boxes, etc., was also assumed.

**Operating schedule.** A 105-day (3.5-month) growout period, with the growout divided into three 35-day periods with respect to aerator operation and water exchange rates, was assumed. For aeration, the following schedule was assumed:

Time Period (days)	Percent of Total Aeration Capacity Operated per Pond During Period
1 – 35	10
36 – 70	40
71 – 105	75

**Operating energy and costs.** A 1 hp electric motor will draw about 15 amps at 115 volts. This is equivalent to 1,725 watts or 1.725 kw. For 24 hours of continuous operation, this motor will draw 41.4 kw-hour. In Hawaii and Taiwan with respective energy costs of \$.11/kw-hour and \$.048/kw-hour, the daily operating costs for a 1-hp motor are \$4.55 and \$1.99 respectively.

The aerator energy consumption for each 35-day growout period in a 1/4-ha concrete pond was calculated as follows:

$$(\text{days}) \times (\% \text{ operational capacity}) \times (\text{hp per pond}) \times (\text{kw-hour/hp/day})$$

$$(35 \text{ days}) (10\%) (3 \text{ hp}) (41.4 \text{ kw-hour/hp/day}) = 434.7 \text{ kw-hour}$$

$$(35 \text{ days}) (40\%) (3 \text{ hp}) (41.4 \text{ kw-hour/hp/day}) = 1,738.8 \text{ kw-hour}$$

$$(35 \text{ days}) (75\%) (3 \text{ hp}) (41.4 \text{ kw-hour/hp/day}) = 3,260.2 \text{ kw-hour}$$

$$\text{Total Energy} = 5,434 \text{ kw-hour}$$

The total energy consumption per 1/4-ha pond per crop is 5,434 kw-hour. The energy consumption for a 1/2-ha pond is double this value. For a 4-ha farm with two crops and 2.5 crops per year in Taiwan and Hawaii respectively, total yearly aeration energy consumption is:

$$\begin{array}{l} \text{Taiwan} \\ (16 \text{ ponds}) (5,434 \text{ kw-hour/crop/pond}) (2 \text{ crops/year}) = 173,888 \text{ kw-hour} \end{array}$$

$$\begin{array}{l} \text{Hawaii} \\ (16 \text{ ponds}) (5,434 \text{ kw-hour/crop/pond}) (2.5 \text{ crops/year}) = 217,360 \text{ kw-hour} \end{array}$$

The aeration costs per 1/4-ha pond per crop are:

$$\begin{array}{l} \text{Taiwan} \\ (5,434 \text{ kw-hour}) (\$.048/\text{kw-hour}) = \$260.83 \end{array}$$

$$\begin{array}{l} \text{Hawaii} \\ (5,434 \text{ kw-hour}) (\$.11/\text{kw-hour}) = \$597.74 \end{array}$$

The yearly aeration costs per 4-ha farm are:

$$\begin{array}{l} \text{Taiwan} \\ (173,888 \text{ kw-hour}) (\$.048/\text{kw-hour}) = \$8,346.62 \end{array}$$

$$\begin{array}{l} \text{Hawaii} \\ (217,360 \text{ kw-hour}) (\$.11/\text{kw-hour}) = \$23,909.60 \end{array}$$

### **Water Pumping and Exchange**

**Sizing.** For the farms surveyed, the average water pump hp/ha ranged from 2.2 to 26.2, with an average of 6.4. For the economic analysis, 10 hp/ha was used. For a 4-ha farm, four wells, with two 10-hp freshwater pumps and two 10-hp seawater pumps, (40 hp total) were assumed. During 1985, costs of \$3,800/pump set-up (exclusive of well costs) or \$15,200 for a 4-ha farm were assumed. A 6-year life of the pumps with no yearly maintenance costs was also assumed.

Central to the sizing question is the water exchange rate as a percentage of the pond volume per day and per growout cycle. Although the pump size and number at the farms was documented during the survey, pumped volumes or pumping schedules were not documented. All farmers interviewed indicated they exchanged water based on "experience," "as needed," or to maintain proper salinity and water quality.

As a rule of thumb, intensive shrimp culture requires an average water exchange rate of 10%/day for the entire farm. A 4-ha farm, with a 2-m water depth, will contain about 80,000 m<sup>3</sup> of water or 21,164 million gallons. With a water exchange rate of 10% per day, the total water flow rate would be 1,470 gpm or 368 gpm per 10-hp pump. This is well within the likely pumping rate for a 10-hp

pump, considering line losses and other inefficiencies. For the purposes of this analysis, a pumping rate of 459 gpm for a 10-hp pump was assumed.

### Operating Schedule

Assuming a 105-day growout period, with the growout divided into three 35-day periods and a 10% overall water exchange rate for the growout, a water exchange rate schedule was assumed as follows:

Time Period (days)	Percent Daily Water Exchange Rate
1 – 35	0
36 – 70	10
71 – 105	20

Based on total electrical costs from the survey, reported costs by Chiang and Liao (1985), and expected water pumping rates for a 10-hp pump, it is believed that in practice less than 10% daily water exchange is used in Taiwan. The total is probably closer to 8%, but this cannot be verified.

### Operating Energy and Costs

A 1/4-ha concrete pond, 2 m deep, will contain 5,000 m<sup>3</sup> (1.323 million gallons) of water. A 10% average water exchange rate will require the equivalent of 91.9 gallons per minute (gpm) of continuous pumping during the entire growout cycle. It was assumed that a 10-hp water pump would produce 459 gpm or 45.9 gpm/hp. These values yield a horsepower requirement of 2 hp continuously for a 1/4-ha growout pond.

A 2-hp pump would draw 82.8 kw-hour per day (2 hp x 41.4 kw-hour/hp/day) of energy. For the entire 105-day growout, this would amount to 8,694 kw-hour per crop per 1.4-ha pond.

Total yearly pumping energy consumption for a 4-ha farm, with two crops and 2.5 crops per year in Taiwan and Hawaii respectively, is:

#### Taiwan

$$(16 \text{ ponds}) (8,694 \text{ kw-hour/crop/pond}) (2 \text{ crops/year}) = 278,208 \text{ kw-hour}$$

#### Hawaii

$$(16 \text{ ponds}) (8,694 \text{ kw-hour/crop/pond}) (2.5 \text{ crops/year}) = 347,760 \text{ kw-hour}$$

The pumping costs per 1/4-ha pond per crop are:

Taiwan  
(8,694 kw-hour) (\$.048/kw-hour) = \$417.31

Hawaii  
(8,694 kw-hour) (\$.11/kw-hour) = \$956.34

The yearly pumping costs per 4-ha farm are:

Taiwan  
(278,208 kw-hour) (\$0.48/kw-hour) = \$13,353.98

Hawaii  
(347,760 kw-hour) (\$.11/kw-hour) = \$38,253.60

Pumping costs for a 4-ha earthen pond farm would be the same as for a 4-ha concrete pond.

#### **Total Aeration and Pumping Costs Per Hectare Per Crop**

Based on the calculations, total energy costs per ha per crop for aeration and pumping would be:

	Aeration	Pumping	Total
Taiwan	\$1,041	\$1,669	\$2,710
Hawaii	\$2,391	\$3,825	\$6,216

Chiang and Liao (1985) estimate average total electrical costs per ha for intensive shrimp farms in Taiwan as \$2,200.



## Appendix D. Pond Layout and Construction Estimates in Hawaii

### Earthen Ponds

The layout for the earthen pond used in the economic analysis for a shrimp farm in Hawaii includes a double row of four, 1/2-ha, square ponds (Figure D-1). Total water surface area is 4 ha with 2 m maximum water depth and 0.3 m freeboard at maximum water level. The slope of the dikes is 2:1 with 3-m (10 ft) wide berms on the central dikes and 4.6-m (15 ft) wide berms on the outer dikes. Total land area for the pond complex measures 315 m x 165 m or 5.2 ha. Embankment volume is 30,367 m<sup>3</sup>. At \$4/m<sup>3</sup>, excavation cost is \$121,470. Total land area is 7 ha, allowing space for house, office, feed storage, equipment and shop building, wells, perimeter zone, fence, and roads. Construction costs for these and other items for earthen ponds in Hawaii are shown in Table 4.

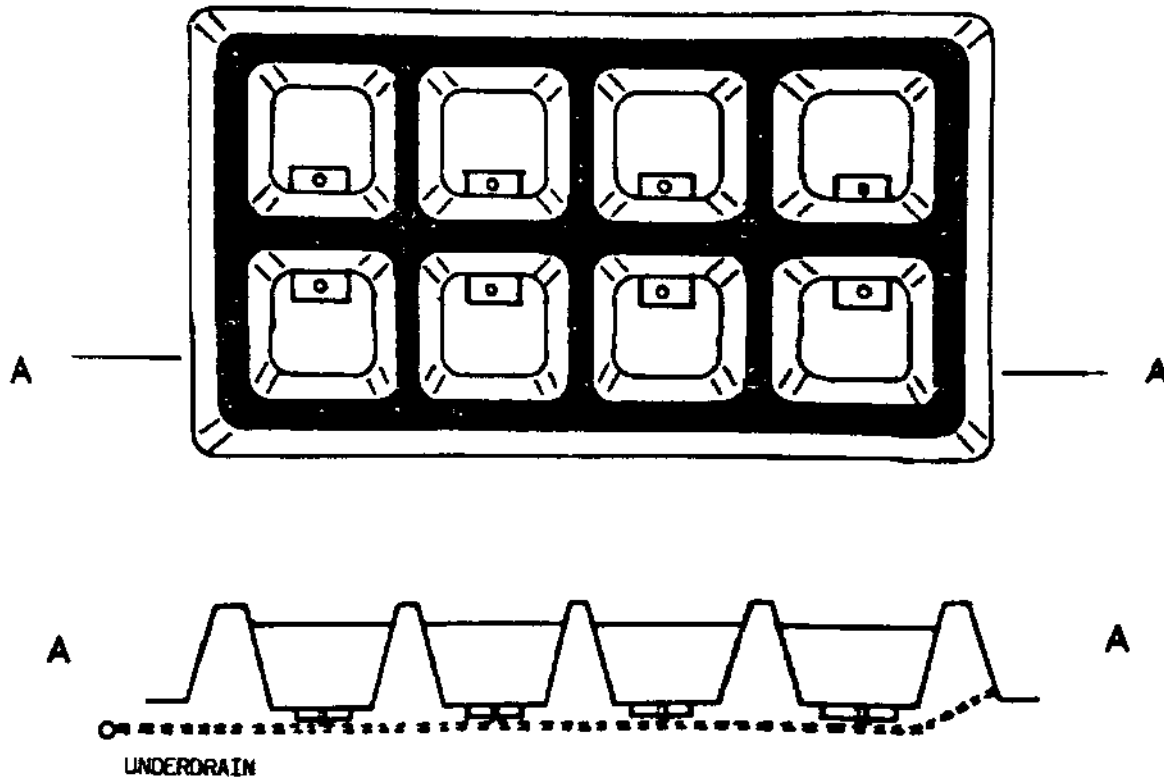

Figure D-1. Layout for earthen pond option for Hawaii used in "Economic Analysis" section of this report. A plan view and a side view are shown.

Only \$30,000 was estimated for wells for earthen ponds, as well as for concrete ponds. This estimate could be low depending on the specific location, because 0.3-m diameter well costs in Hawaii during 1981 were \$3,772/m (\$1,150/ft) (Shang 1981). Four 10-hp water pumps to meet a 4-ha farm water needs was estimated. The objective is to achieve water salinities of 10 to 20 ppt through either a single well within this range or through multiple wells where this salinity can be achieved through blending of higher and lower salinity waters. A \$30,000 budget item for wells therefore provides only 8 m (26 ft) of 0.3-m diameter well footage.

\$30,000 for farm permits was estimated. In Hawaii, 45 permits are currently required to build an aquafarm in the coastal zone. Some of these permits require public hearings and perhaps environmental reports. Permit acquisition currently could range from \$10,000 to \$150,000 for a given farm, exclusive of certain hearing and legal costs (W.A. Brewer, William A. Brewer & Associates, 1987: pers. com.). For the purposes of this analysis, it was assumed the shrimp farming industry has grown to a substantive size in Hawaii and has therefore established precedence and a solid data base for permit acquisition. These developments should therefore reduce permit acquisition costs below those experienced by the pioneer farms.

All Taiwan prawn farms have housing on-site, ranging from a simple room or shed to elaborate dwellings. For the purpose of this study's projections, a modest house by Hawaii standards, built to code and costing \$30,000 for materials and \$30,000 for labor, was assumed. This housing would be provided for the farm manager as partial compensation. At the same time, the manager would be on station continuously, thereby providing labor and management inputs over and above those normally provided by other professionals.

For the earthen pond option, it was estimated that 627 m (2,056 ft) of 20.3-cm (8-inch) effluent PVC pipe will be required. At \$49.20/m (\$15/ft) installed, total cost for the drain (effluent) plumbing will total \$30,800. For the water supply plumbing (influent supply), a total of 627 m of 7.6- to 10.2-cm (3- to 4-inch) pipe was estimated. At \$26.24/m (\$8/ft) installed, total cost for the water supply pipe will be \$16,500.

### **Concrete Ponds**

The layout for the concrete-walled pond option used in the economic analysis for a shrimp farm in Hawaii includes a square matrix of 16 1/4-ha, square ponds (Figure D-2). Total water surface area is 4 ha with a 2-m maximum water depth. The wall design and construction costs are given in Appendix B for the new pond case. This design is very similar to that described by Liu and Mancebo (1983) (Figure D-3).

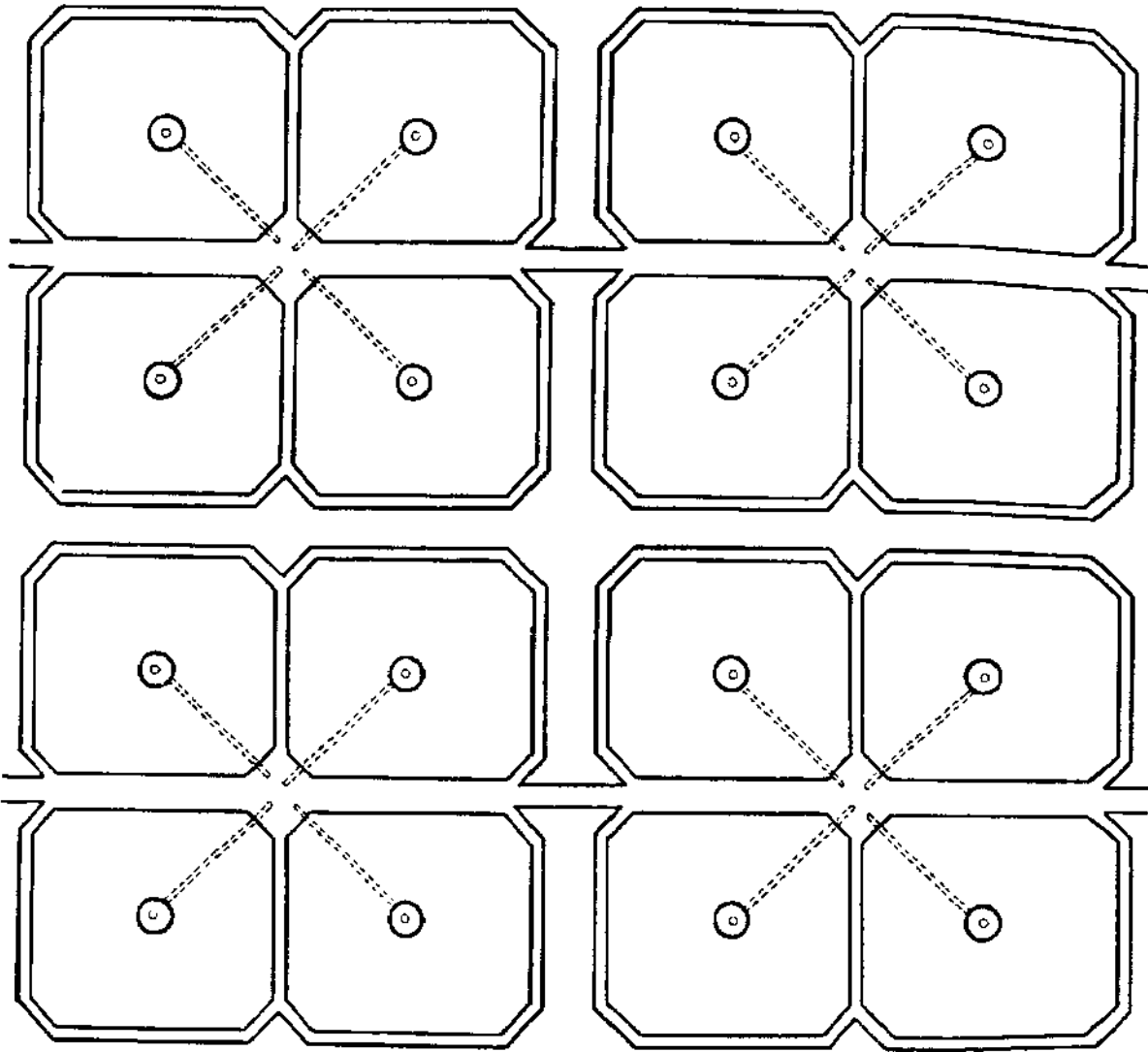

Figure D-2. Layout for concrete pond for Hawaii used in "Economic Analysis" section of this report.



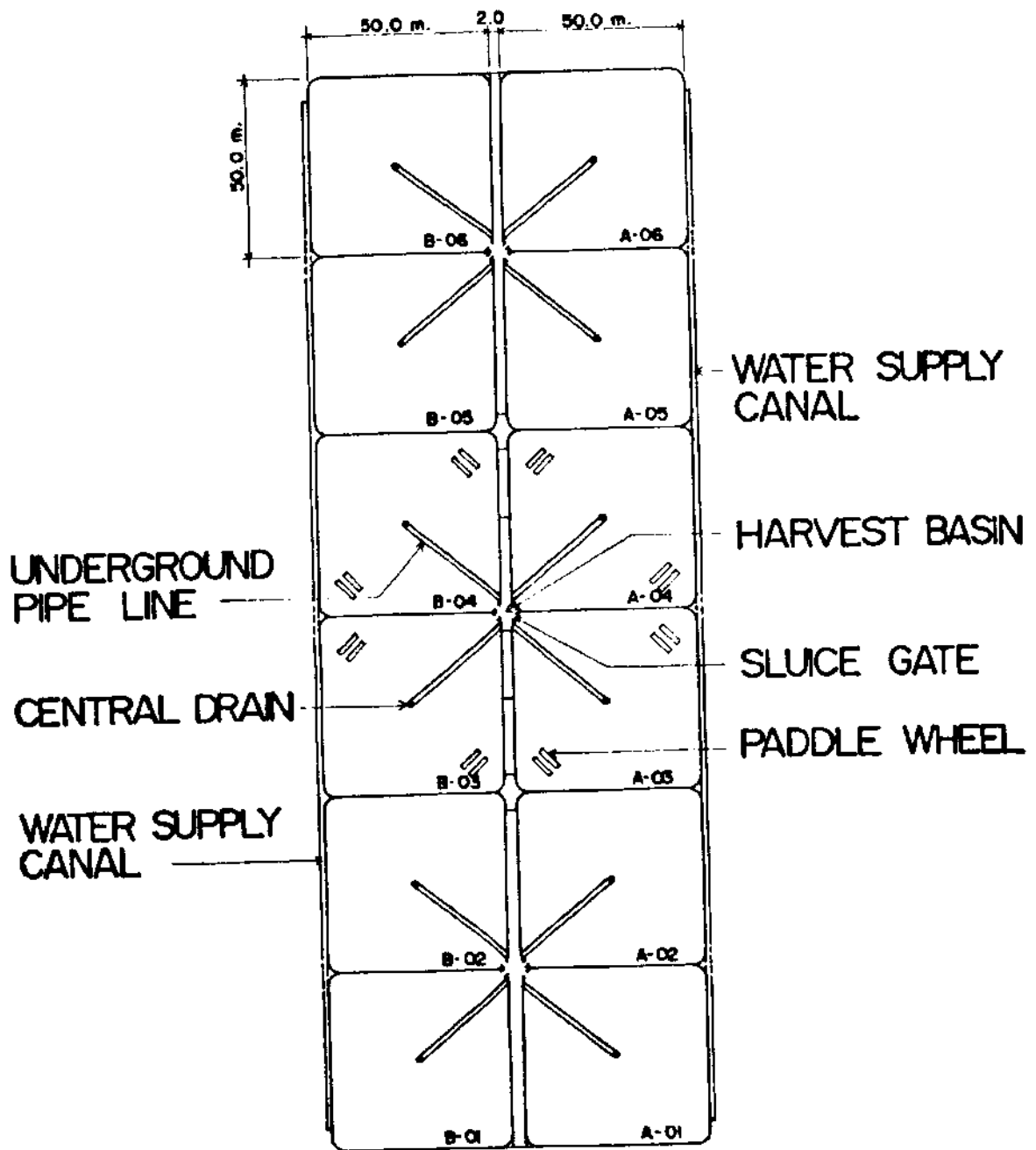

Figure D-3. Concrete-walled pond design with center drains (Liu and Mancebo 1983).

Total land area for the farm in the Hawaii analysis is 5 • ha, allowing space for the same items listed for the earthen pond case. Likewise, the same costs for permits, wells, pumps, etc. as listed for the earthen pond case were assumed. Total cost estimates for the concrete pond case are detailed in Table 4.