

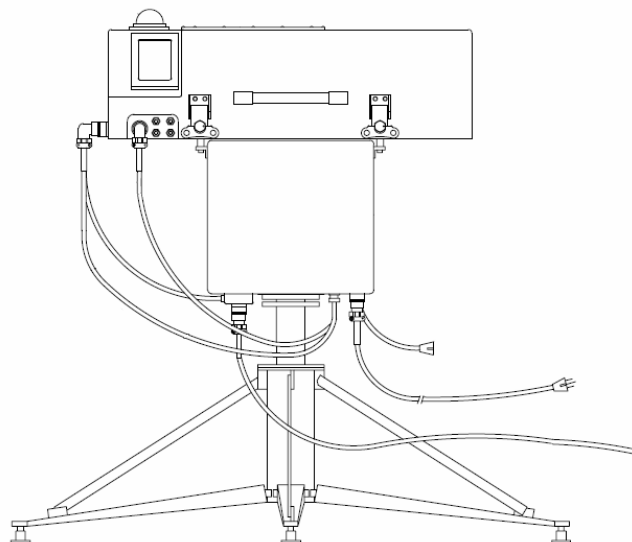

National Oceanic and Atmospheric Administration
Environmental Protection Agency
Ultraviolet Radiation and Ozone Monitoring
Brewer Network



Brewer Site Operators Handbook

Prepared by
NOAA/ESRL/GMD
Solar Radiation Research Branch
Boulder, Colorado

Version 1.0
June 8, 2006

Table of Contents

1	Introduction	1-1
1.1	Brewer MKIV Spectrophotometer	1-1
1.2	Standard Maintenance Procedures	1-2
1.3	Precautions	1-2
1.4	Required Tools and Supplies	1-3
1.4.1	Tools	1-3
1.4.2	Supplies	1-3
2	Site Visit Procedures	2-1
2.1	Logging Visits and Changes to the System	2-1
2.1.1	The Log Book	2-1
2.1.2	Electronic Log Entries	2-1
2.2	Daily/Weekly Maintenance Procedures	2-1
2.2.1	Brewer Computer System Checks - Daily	2-2
2.2.2	Brewer Checks – Daily/Weekly	2-2
2.2.3	Tracker Checks – Bi-Monthly	2-3
3	Brewer Control Computer	3-1
3.1	Hardware Configuration	3-1
3.2	Windows Software Configuration	3-1
3.2.1	PC Operating System	3-2
3.2.2	PC Brewer Software	3-2
3.2.3	PC Remote Control Software	3-3
3.2.4	PC Time-Keeping Software	3-3
3.2.4.1	NIST Time Program	3-3
3.2.4.2	PC Clock Program	3-4
3.2.5	PC Automatic Reboot	3-6
3.2.6	PC System Uptime Monitor	3-7
3.2.7	PC Scheduling Software	3-7
3.3	Brewer-to-PC Communications Interface	3-9
3.3.1	RS-232	3-9
3.3.2	RS-485 Converters	3-10
3.3.2.1	ICC-11 RS-232-RS485 Converter	3-10
3.3.2.2	IC-485s RS-232-RS-485 Converter	3-10
4	Brewer Spectrophotometer Maintenance	4-1
4.1	Cleaning External UV Dome and Quartz Window	4-1
4.2	Enclosure Cover Removal and Maintenance	4-1
4.3	Checking Humidity Indicators	4-2
4.3.1	Humidity Monitor Strip	4-2
4.3.2	Breather Tube Desiccant	4-3
4.3.3	Spectrometer Humidity Indicator	4-3
4.4	Desiccants	4-3

Contents

4.4.1	Changing Desiccant Packs	4-3
4.4.2	Changing Breather Tube Desiccant	4-4
4.5	Sun Sighting Alignment	4-4
4.5.1	Procedure	4-4
4.5.2	Sun Sighting Troubleshooting	4-10
5	Tracker Maintenance	5-1
5.1	Tracker Mechanical Inspection	5-1
5.2	Tracker Azimuth Wheel Maintenance	5-1
5.3	Tracker Over-Rotation Protection Switch	5-3
Appendix A	Day of Year Calendars	A-1

List of Figures

Figure 1-1	Complete Brewer Spectrophotometer System	1-1
Figure 1-2	Top View of Brewer Enclosure	1-2
Figure 2-1	Brewer Status and Operation Indicators	2-2
Figure 2-2	Humidity Indicator	2-3
Figure 3-1	Windows Task Bar on Brewer PC with Internet Connectivity	3-2
Figure 3-2	Brewer Software Display Information	3-3
Figure 3-3	NIST Time Client Window	3-4
Figure 3-4	PC Clock Program Window	3-5
Figure 3-5	PC Clock Configuration Screen	3-5
Figure 3-6	WinOFF Reboot Clock	3-6
Figure 3-7	WinOFF Shut down programming Screen	3-6
Figure 3-8	WinOFF Options Screen	3-7
Figure 3-9	System Uptime Monitor Screen	3-8
Figure 3-10	Macro Scheduler Software	3-8
Figure 3-11	RS-485 Converter By-Passed in Brewer Chassis	3-9
Figure 3-12	RS-485 Converter Connected in the Brewer Chassis	3-10
Figure 3-13	ICC-11 RS-485 Converter Wiring Diagram	3-11
Figure 3-14	IC-485s RS-485 Converter Wiring Diagram	3-12
Figure 4-1	Brewer Routine Glass Cleaning	4-1
Figure 4-2	UV Dome Protector	4-1
Figure 4-3	Inside Cover Weather-Seal	4-2
Figure 4-4	Latch Maintenance	4-2
Figure 4-5	Humidity Indicator Locations	4-2
Figure 4-6	Humidity Monitor Strip	4-2
Figure 4-7	Breather Tube Desiccant	4-3
Figure 4-8	Spectrometer Humidity Indicator	4-3

Figure 4-9	Desiccant Pack Locations	4-4
Figure 4-10	Brewer Computer Display	4-5
Figure 4-11	Brewer SI Command Screen	4-6
Figure 4-12	Overview of the Brewer Sun Sighting Mechanism	4-6
Figure 4-13	Visible shadow caused by Brewer's azimuth alignment being rotated too far in the clockwise (CW) direction	4-7
Figure 4-14	Brewer with proper azimuth alignment. No shadow may also indicate azimuth is rotated too far in the counter- clockwise (CCW) direction	4-7
Figure 4-15	Zenith Prism Maximum Rotations	4-8
Figure 4-16	Looking through sighting tubes without blocking the Quartz Window from the Sun	4-9
Figure 4-17	Locations of Tracker Sighting Adjustment Buttons	4-9
Figure 4-18	Image of Sun improperly aligned on the on face of the Iris	4-9
Figure 4-19	Image of Sun properly aligned on the face of the Iris	4-9
Figure 4-20	Entrance Slit improperly aligned	4-10
Figure 4-21	Entrance Slit properly aligned	4-10
Figure 5-1	Brewer Computer Display	5-1
Figure 5-2	Tracker Cover Plate Captive-Nuts	5-2
Figure 5-3	Tracker Azimuth Wheel Cleaning	5-2
Figure 5-4	Tracker Over-Rotation Protection Switch	5-3

This page intentionally left blank

1 Introduction

This Brewer Site Operators Handbook contains specific information and procedures required to successfully maintain the Brewer MKIV Spectrophotometer. In many instances, excerpts from Sci-Tech's™ Operators Manual are used or referenced in this document.

1.1 Brewer MKIV Spectrophotometer

The Brewer Spectrophotometer is a scientific instrument which measures Ultra Violet, or Visible, radiation in the solar spectrum. By examining the differential absorption of select wavelengths in the UVB portion of the spectrum, determinations of Total Column Ozone (O_3) and Total Column Sulphur Dioxide (SO_2) are inferred. The MKIV instrument measures intensity of radiation in the visible part of the spectrum (430-450nm) and uses differential absorption in this region to infer Total Column Nitrogen Dioxide (NO_2).

The Brewer Spectrophotometer is core component of a complete Brewer system which includes the following: Spectrophotometer, Azimuth Tracker, Tripod Base, IBM compatible PC, and a Tractor-Feed Printer. [Figure 1-1](#) identifies the major parts of the Brewer system. [Figure 1-2](#) shows the top view the Brewer cover identifying the controls and features used to manipulate and calibrate the instrument.

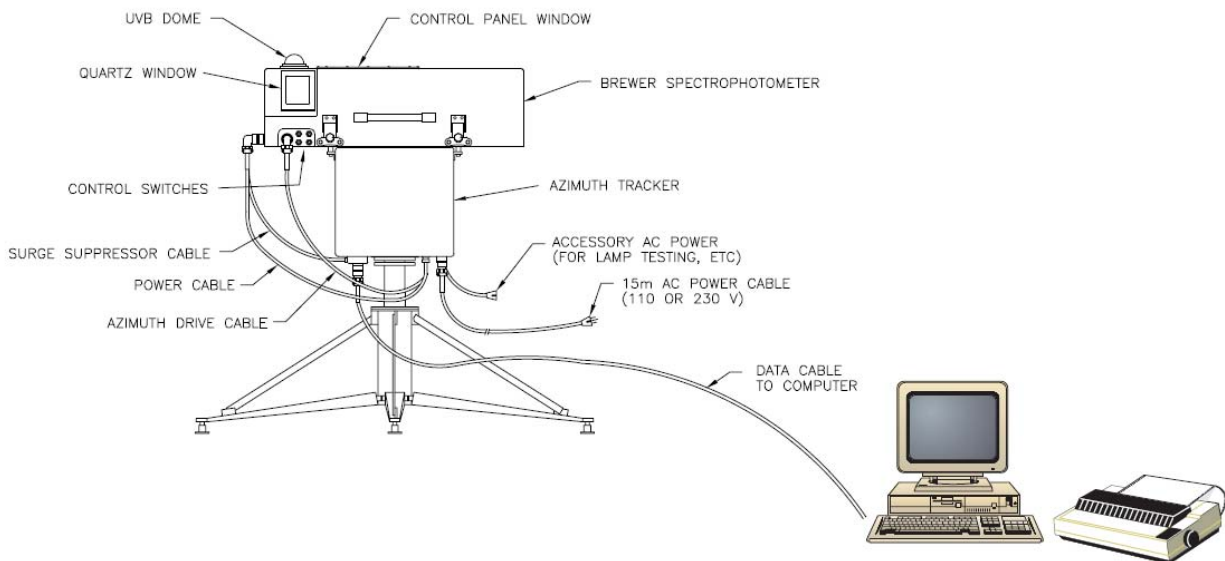

Figure 1-1 Complete Brewer Spectrophotometer System

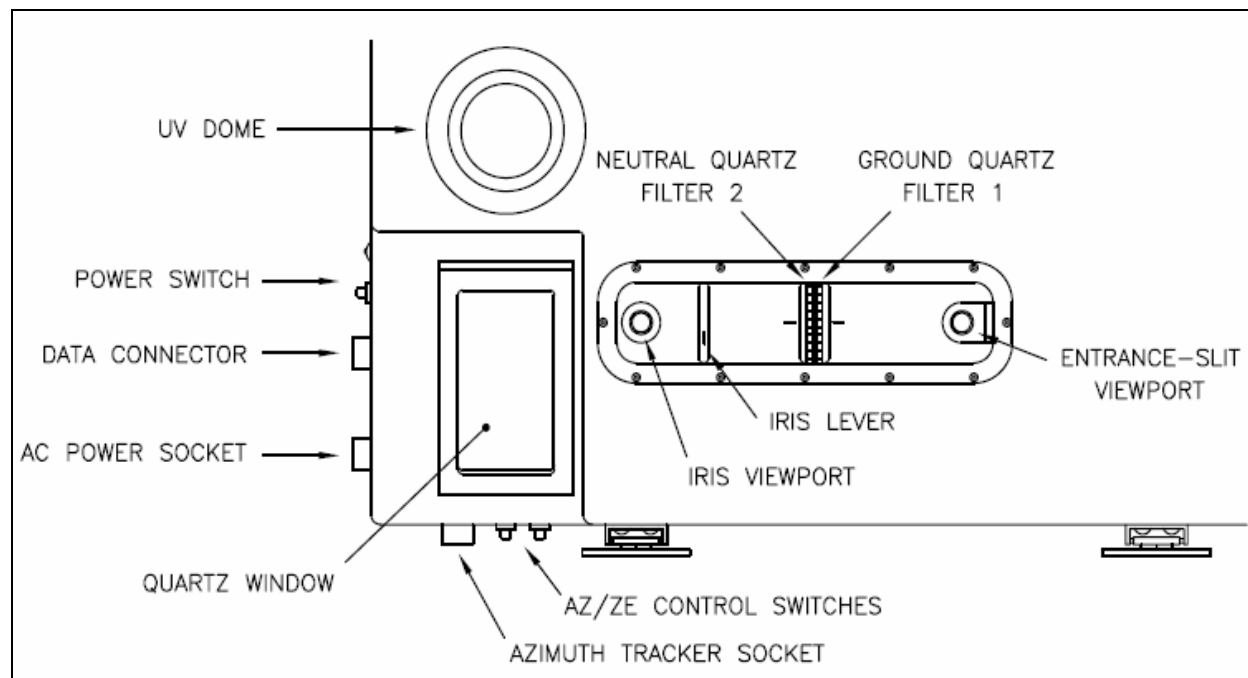

Figure 1-2 Top View of Brewer Enclosure

1.2 Standard Maintenance Procedures

In order to ensure proper operation of the Brewer Spectrophotometers, the Standard Maintenance Procedures (SMP) outlined in this document should be followed by the local site operator. Ideally, the instrument should be visited once per day but, realistically, a visit once or twice per week by the site operator should be sufficient in most cases to verify and maintain operation. Section 2 provides a condensed version of the SMP. Sections 3, 4, and 5 provide detailed information about the various procedures.

1.3 Precautions

- Never remove the Brewer enclosure cover during high-winds, dusty conditions, or when any amount of precipitation is occurring.
- Never touch, blow-on (or even breath-on) or attempt to clean any of the Brewer's internal optics (lenses, mirrors, or grading).
- When removing the Brewer enclosures cover is required, always cover the UV Dome with the protective shroud provided.
- Never set the Brewer enclosure cover on the ground or on its side where the cover could fall, resulting in UV Dome or Quarts Window damage.

1.4 Required Tools and Supplies**1.4.1 Tools****Table 1-1 Required Tools**

Quantity	Description	Purpose
1	5/32" x 6" Allen-Head Wrench	Attach Brewer to Tracker Adjust Tracker Tension
1	3/16" x 6" Allen-Head Wrench (**Right Angle)	Tracker Cover Remove/Attach Tracker Ground Strap Attachment**
2	9/16" Open-End Wrench	Tracker Tripod Assembly/Adjustment
1	3/4" Crescent Wrench	General Purpose Use
1	Medium Size Channel-Lock Pliers	Loosen Military-Style Connectors
1	1/4" x 8" Flat-Blade Screwdriver	Tracker Leveling
1	3/4" Open-End Wrench	Tracker Leveling Adjustment

1.4.2 Supplies**Table 1-2 Required Brewer Site Supplies**

Quantity	Description	Purpose
1+	Box of KemWipes or Roll of Soft Paper Towels	Clean Brewer UV Dome and Quartz Window. Clean the Tracker Wheel and driveshaft.
1	Bottle of Mild Glass Cleaner	Clean Brewer UV Dome and Quartz Window. Clean the Tracker Wheel and driveshaft.
2	Light-Weight Machine Oil	Lubricate Brewer Cover Hasps.
1	Tube of Grease	Lubricate and protect Tripod Leveling Feet from rust.
1	High Temperature Miller Stephenson KRYTOX GPL 200 Grease	Lubricate the internal Micrometer.
16	Desiccant Packs (sealed 4oz.)	Placed inside Brewer Enclosure

This page intentionally left blank

2 Site Visit Procedures

2.1 Logging Visits and Changes to the System

Logging visits to the site and recording any changes made to the Brewer's operation or configuration are extremely important to historical record of each Brewer Instrument. Log entries should be made both electronically and also written into the Brewer's Log Book. At a minimum, make sure to log all changes and maintenance events into the electronic log (see Section 2.1.2).

2.1.1 The Log Book

Each Brewer site has a Log Book to record information about any changes to the operation and all maintenance activities performed on the Brewer system.

2.1.2 Electronic Log Entries

Electronic Log Entries are made using the Brewer Control Program **CO** command which allows the operator to enter a comment (up to 75 characters). CO comments are integrated into the Brewers B-File for the current date.

1. On the Brewer Control Computer (see [Figure 2-1](#)), observe the current mode of operation, if the instrument is currently taking **HG** or **UX** measurements, do NOT interrupt the scan, wait for the scan to complete. Press the **HOME** key to terminate any measurement except **HG** or **UX** scans.
2. Enter **CO**<CR> from the Brewer Main Menu.
3. Enter the comment (up to 75 characters). Press **Enter** to commit the comment. If the comment requires more than 75 characters, the operator can issue as many **CO** commands as required to properly document the entry. Each entry is automatically time-stamped, so it is not necessary to include timestamp information in the comment text.
4. Restore the Brewer to its automatic continuous schedule by issuing a **SKC** <CR> command. When prompted, enter **EPA96D** <CR> (the name of the Brewer schedule file).

2.2 Daily/Weekly Maintenance Procedures

Some of the following routine maintenance procedures, ideally; would be done on a daily basis, realistically; once or twice a week is all the operator may be able to accommodate.

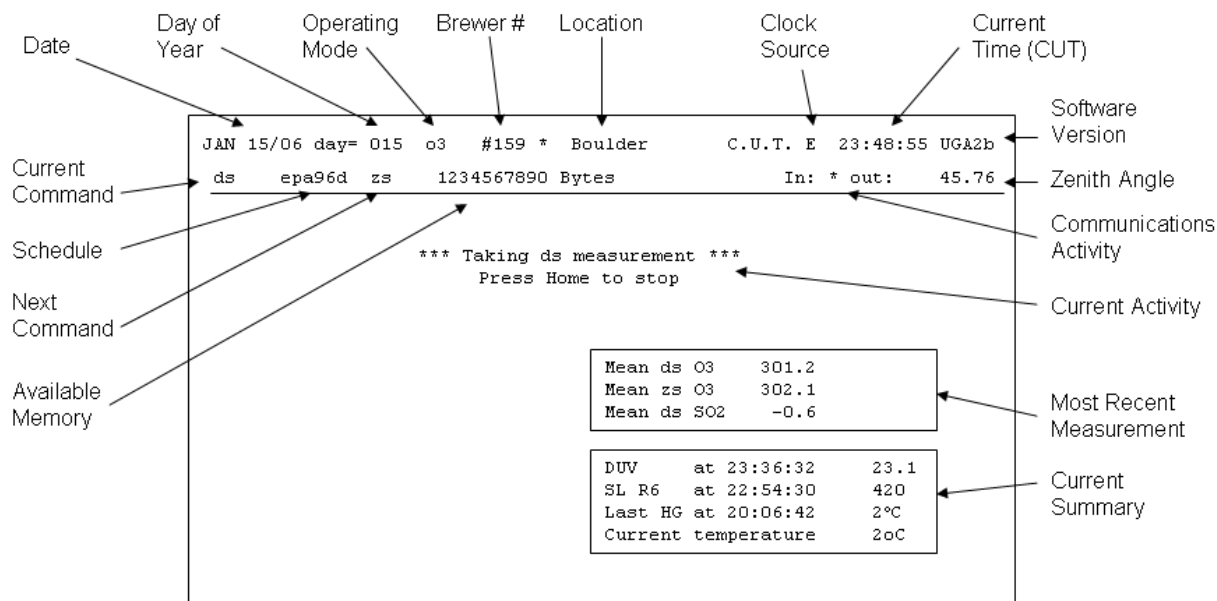

Figure 2-1 Brewer Status and Operation Indicators

2.2.1 Brewer Computer System Checks - Daily

1. Verify the Brewer software program is running, and that the system is not locked-up or in a power-saving state.
2. Verify the Brewer date/time (see Figure 2-1) is set as close as possible to NIST time standard. If the site has internet access the NIST time page can be used as a reference (see <http://www.time.gov/timezone.cgi?UTC/s/0/java>). If the date is incorrect, the date can be set using the **DA** command. If the time is off by more than several seconds, the time can set manually using the **TI** command. Log any discrepancy and corrective action using the procedure described in Section 2.1.2.
3. Verify the Brewer is executing its continuous automatic schedule. If the Brewer is not executing its automatic schedule, start the schedule by issuing a **SKC <CR>**, and entering the schedule name **EPA96D <CR>**



2.2.2 Brewer Checks – Daily/Weekly

1. Verify the Brewer is tracking the Sun by observing the rotation of the Tracker. If the Brewer is taking an *Umkehr* (**UM**) measurement the Brewer Quartz Window will be rotated perpendicular to the Sun. In all other measurement modes, the Brewer's Quartz Window should be squarely facing the Sun and the Zenith Prism elevation should be tracking the Sun's elevation.

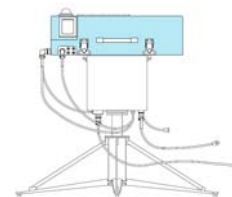

2. Verify Power Indicator LEDs on both the Brewer and Tracker are illuminated.
3. Check the condition of the Humidity Monitor located on top of the Brewer Enclosure between Filter Wheel #1 and the Entrance Slit View Tube. The Humidity Indicator's circles change color from blue to pink if the humidity has reached specified levels (see [Figure 2-2](#)). If the Humidity inside the Brewer is greater than 20%, follow the Desiccant Pack Replacement Procedure defined in [Section 4.4](#). Make log entries noting the humidity indication and any desiccant changes.
4. Check and log the condition (clean, dirty) of the UV Dome and Quartz Window (see [Section 4.1](#)). Clean the UV Dome and Quartz Window using paper towels and glass cleaner.
5. If the intensity of the Sun is bright enough to cast shadows, perform the Sun Sighting Procedure defined in [Section 4.5](#). This procedure should be done once a week. Log the Old/New Horizon and North Correction results of the Sun Sighting in the electronic log and also in the site Log Book.

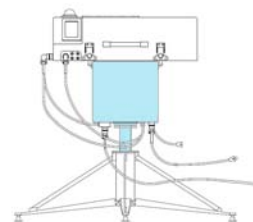

Figure 2-2 Humidity Indicator

2.2.3 Tracker Checks – Bi-Monthly

Regular maintenance on the Tracker is vital to the proper operation of the Brewer.

1. Run the Steps per Revolution Test by issuing a **SR <CR>** command. After the test completes, record the number returned by the test in the log book and electronic log.
2. Inspect and clean the Tracker's aluminum azimuth wheel and stainless steel drive shaft using the procedures defined in [Section 5](#). Even if no slippage is observed in the SR test, the wheel and drive shaft should be cleaned at least once a month. Record the maintenance actions in the site log book and electronic log.



If Tracker slippage is not due to dirty drive mechanism, then azimuth drive mechanism tensions should be checked. Contact Patrick.Disterhoft@noaa.gov if slippage due to drive tension is suspected.

This page intentionally left blank

3 Brewer Control Computer

A Brewer Spectrophotometer requires an external DOS/Windows based Personal Computer (PC) to operate. The Brewer Software is written in GWBasic, and runs in a DOS Shell on most versions of the Windows operating system. The Control Computer provides the following functions:

- Controls the Brewer Spectrophotometer, stores Brewer data.
- Provides remote access/control of the Brewer, and transfer of Brewer data.
- Connects to internet or dial-up NIST time sources to keep PC internal clock accurate.

This remainder of this section describes the control computer's hardware configuration and gives an overview of the installed software packages. The software configuration of the control computer is adapted to suit a particular site's internet connectivity capabilities.

3.1 Hardware Configuration

Brewer sites may or may not have internet connectivity. Brewer Sites that do have internet access use an Ethernet NIC to connect to the existing network infrastructure. Sites that do not have internet access use a dial-up phone line and modem for data access and control. Other than the standard PC components and peripherals, [Table 3-1](#) outlines the hardware options required for internet and non-internet Brewer sites.

Table 3-1 Hardware Configuration

Hardware Specification	Internet	No Internet
RS-232 Serial Communication Port	Required	Required
Printer Parallel Port (if Printer is installed)	Required	Required
Ethernet Network Interface Card	Required	Optional
Internal Modem Card or; Second available RS-232 Serial port and External Modem	Optional	Required

3.2 Windows Software Configuration

This section describes the various software packages installed on the Brewer Control PC if the operating system is Windows 98. The software package configuration depends on the site's internet connectivity. If the site does have an internet connection, specific packages will be enabled, while others may still be installed but not enabled. [Table 3-2](#) shows the software configurations for Brewer sites with and without internet connectivity.

Table 3-2 Software Configuration

Package Name	Purpose	Internet	No Internet
Windows 98	Operating System	Req	Req
Brewer Software	Runs the Spectrophotometer	Req	Req
pcAnywhere	Provides remote access/control and data transfer	Req	Req
NIST Time	Automatically sets time via Internet	Req	Opt
PC Clock	Sets time via modem	Opt	Req
Auto-Reboot	Reboots the PC on a specified schedule	Opt	Opt
Uptime Monitor	Logs Uptime and downtime of the PC	Opt	Opt
Macro Scheduler	Stops/Starts Brewer and PC Clock Software	Opt	Req

3.2.1 PC Operating System

The Brewer Control Computer is using Windows 98 as its operating system. The required programs have been added to Startup menu, and load automatically when Windows boots. The Icons for the programs will appear in the Windows Task Bar located to the bottom of the screen as shown in [Figure 3-1](#).

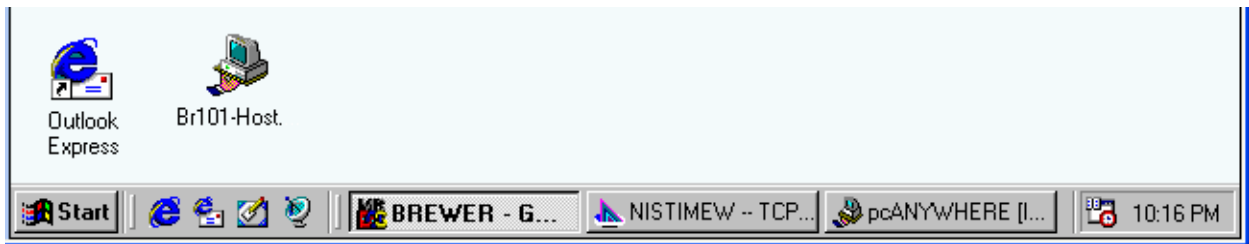

Figure 3-1 Windows Task Bar on Brewer PC with Internet Connectivity

3.2.2 PC Brewer Software

The Brewer Software is written in GWBasic and runs in a DOS shell. The program files are installed in the `C:\brewer` subdirectory, and the Brewer data files are stored in the `C:\bdata` subdirectory. The Brewer program is automatically loaded at boot-time by placing a short-cut to `C:\brewer\brewer.bat` in the Windows *Startup* Folder. For more information about the Brewer Software, consult the Brewer Operators Guide. For quick reference purposes, the major control and monitoring features of the Brewer Software are identified in [Figure 3-2](#).

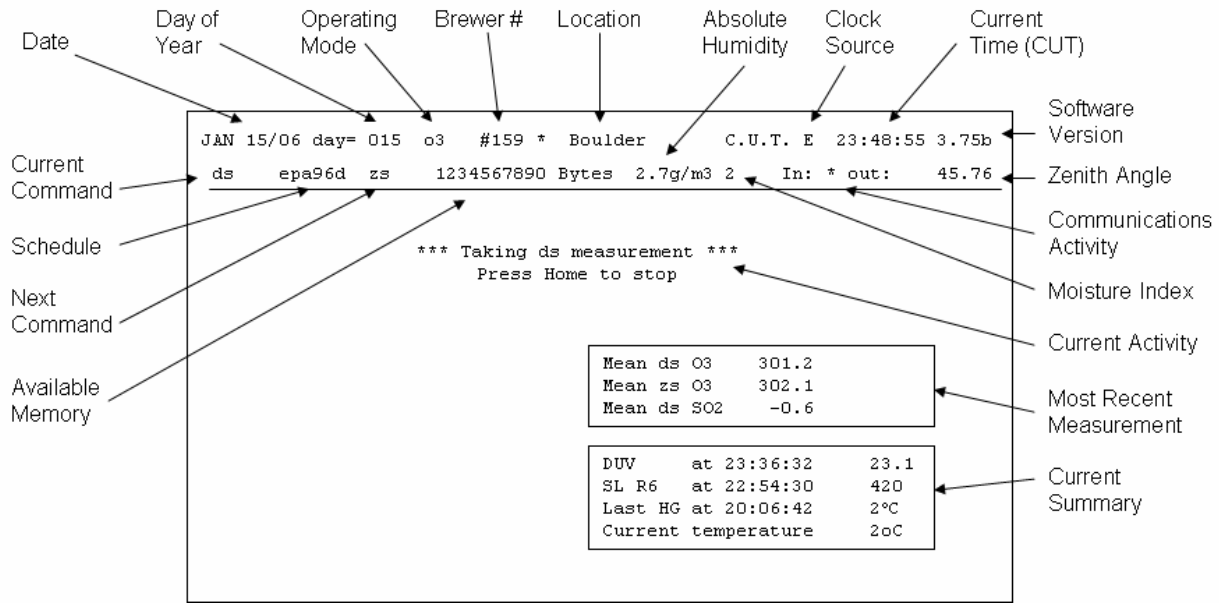

Figure 3-2 Brewer Software Display Information

3.2.3 PC Remote Control Software

Remote Control of the Brewer PC and data transfer is accomplished via *pcAnywhere* Remote Control Software. The Brewer PC is configured to be a *pcAnywhere* Host, and depending on the site's internet capabilities, will be configured to use TCP/IP communications, or configured to use a modem/phone-line if no internet connection exists. The *pcAnywhere* Host program is automatically loaded at boot-time by placing a short-cut to the host configuration file (C:\windows\desktop\BR###.BHF) in the Windows *Startup* folder. When the *pcAnywhere* Host program is running, an icon resides on the Windows Task Bar at the bottom of the screen (see [Figure 3-1](#)).

3.2.4 PC Time-Keeping Software

The Brewer software requires accurate Universal time to properly calculate where the Sun is supposed to be during the day. One of two programs is used to keep the PC system time in sync with the NIST Time Standard. The first, *NIST Time* is used at Brewer sites that do have internet connectivity. The second, *PC Clock* is used at Brewer sites that do not have access to the internet. More information about each of these two programs can be found in the following sections.

3.2.4.1 NIST Time Program

The NIST Time software is installed in C:\NIST Time and is automatically loaded at boot time by a short-cut to C:\NIST Time\nistimew.exe being placed in the Windows Startup folder. Once the program's options are initially configured, no other

actions are required. An example screen capture of the NIST Time Program Screen is shown in [Figure 3-3](#).

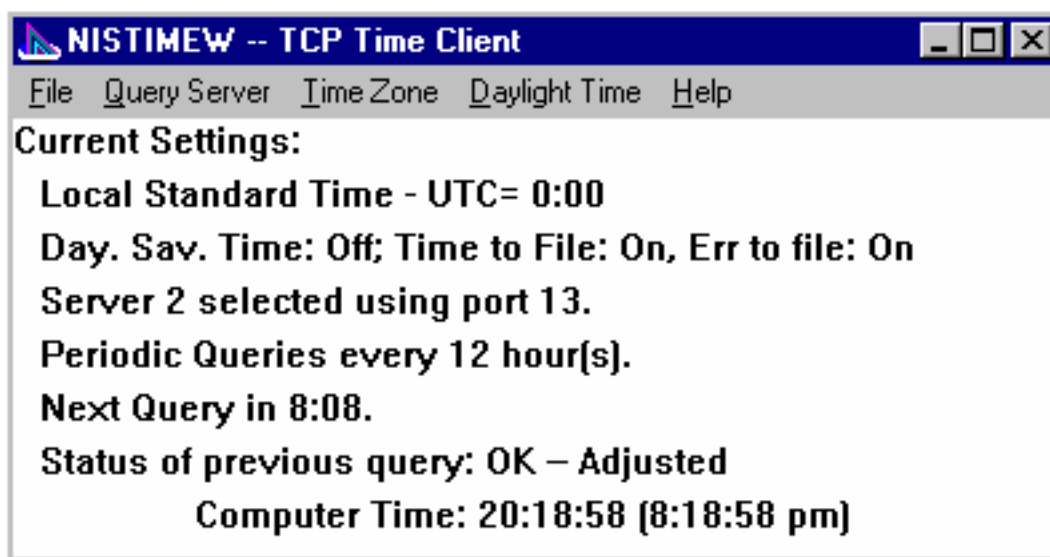

Figure 3-3 NIST Time Client Window

3.2.4.2 PC Clock Program

PC Clock software is used to keep the Brewer PC's clock in sync with the NIST Time standard via dial-out modem. *PC Clock* is for use at Brewer sites that do not have direct internet access. *PC Clock* is installed in `C:\pcclock` subdirectory. Unlike other programs on the Brewer PC, *PC Clock* is not loaded at boot-time, and must be executed programmatically through a scheduling program called *Macro Scheduler*. See [Section 3.2.7](#) for more information about *Macro Scheduler*.

Brewer sites that do not have internet access must share the modem line connection for all communications activities including *pcAnywhere* Remote Control, data transfer, and dial-out time synchronization. Normally, each Brewer site only has one available phone line for modem use, and *pcAnywhere* must have control of the modem for remote access and data transfer. Under these circumstances, a problem comes to surface with resource contention for the modem. The solution to this problem is to use the *Macro Scheduler* program to periodically end *pcAnywhere* and give control of the modem to *PC Clock*. The scheduler then instructs *PC Clock* to connect to NIST and synchronize the time by executing `C:\pcclock\pcclock.exe /A` (automatic option). After *PC Clock* time synchronization has finished, the scheduler then restarts *pcAnywhere* for normal operations.

When *PC Clock* is executing, a Window is opened screen similar to the one shown in [Figure 3-4](#). *PC Clock* has been pre-configured and should not require any user interaction. However, in event the parameters get corrupted, the user can start *PC Clock* manually and press F11 to activate the *PC Clock* configuration Screen (see

Figure 3-5). The user can then use the arrow keys to re-enter the parameters and save them by pressing Enter.

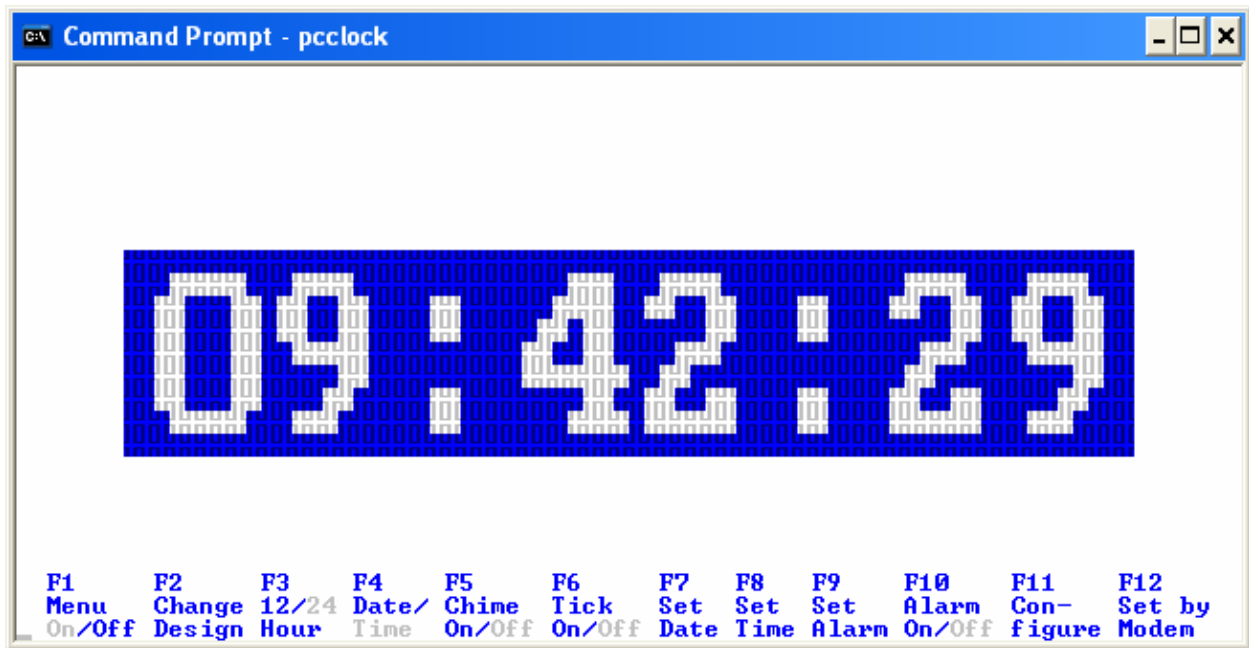

Figure 3-4 PC Clock Program Window

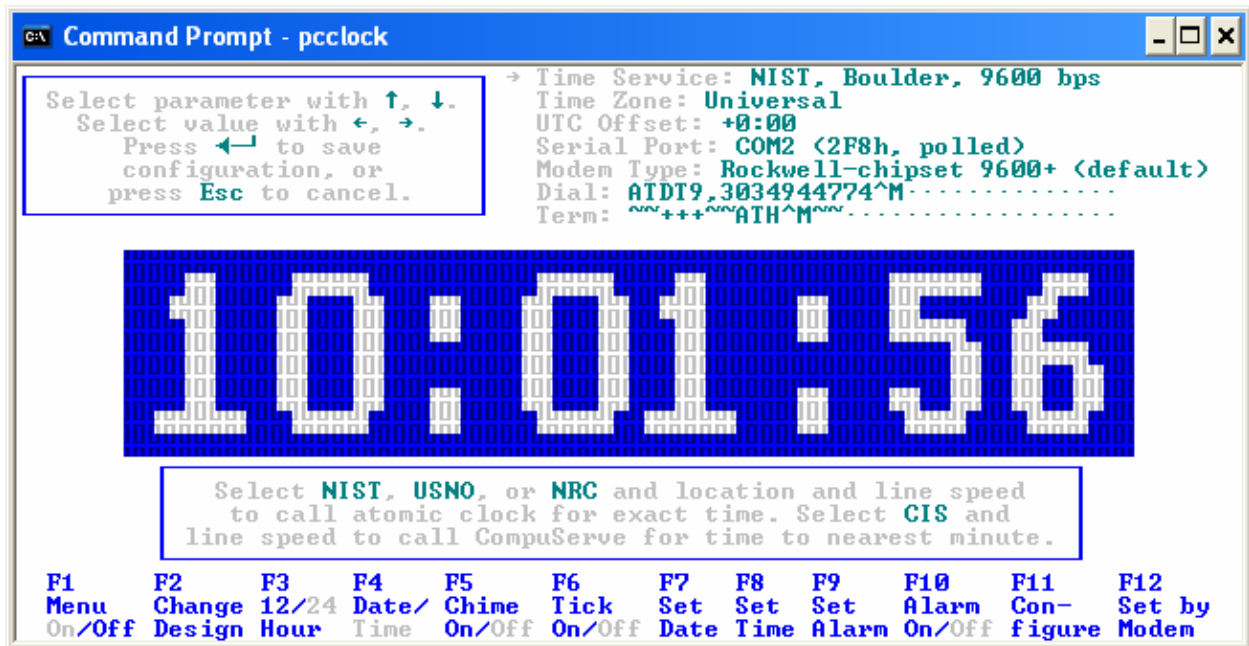

Figure 3-5 PC Clock Configuration Screen

3.2.5 PC Automatic Reboot

Since the Brewer’s run continuously and for the most-part unattended, the ability for the PC to reboot itself on a regular basis is desirable. The software that makes this automatic reboots possible is called *WinOFF*. The *WinOFF* installation program installs into the **C:\Program Files\WinOFF** subdirectory.



Figure 3-6 WinOFF Reboot Clock

This utility loads itself onto the Windows System Tray, and loads automatically at boot-time (no Startup short-cut required). A (optional) clock showing the time of the next scheduled reboot is shown in the lower right of the Desktop (see Figure 3-6). The *WinOFF* configuration screen is activated by right-clicking on the reboot clock and selecting *Configuration*. The options that are critical to correct operation are **high-lighted in orange** in Figure 3-7 and Figure 3-8.

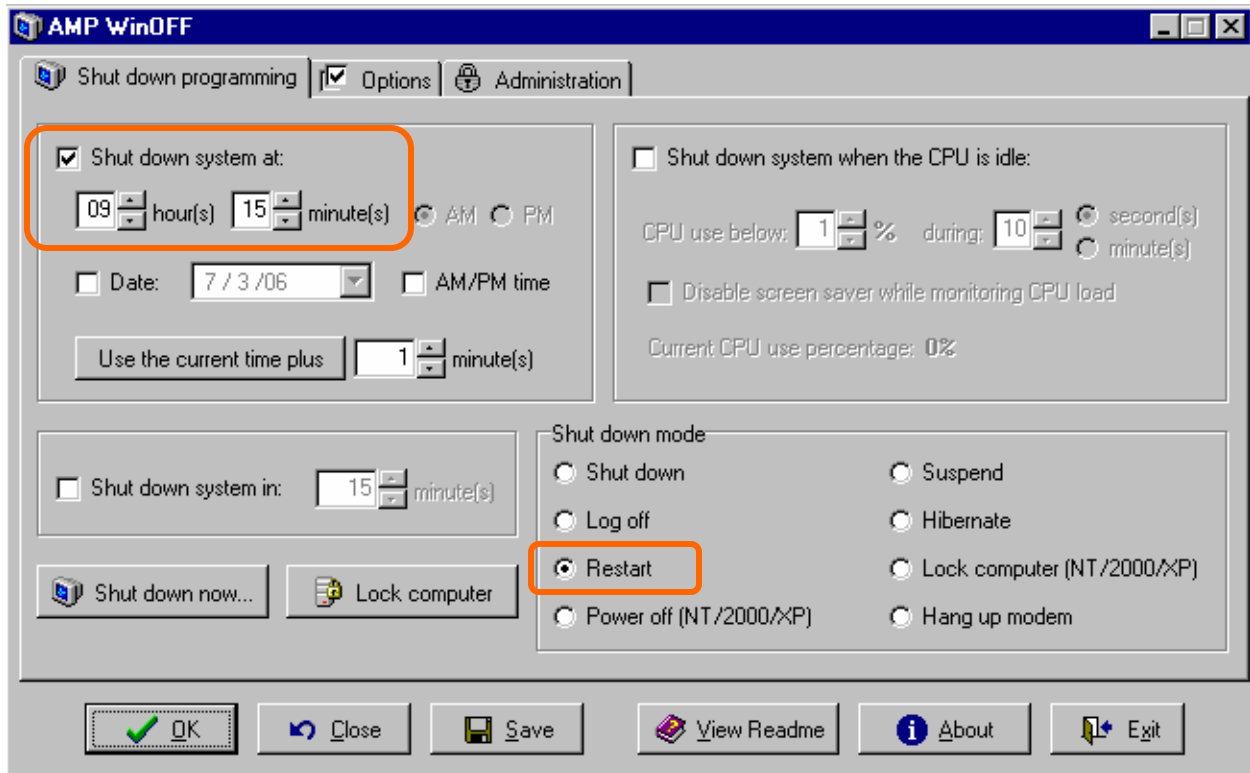

Figure 3-7 WinOFF Shut down programming Screen

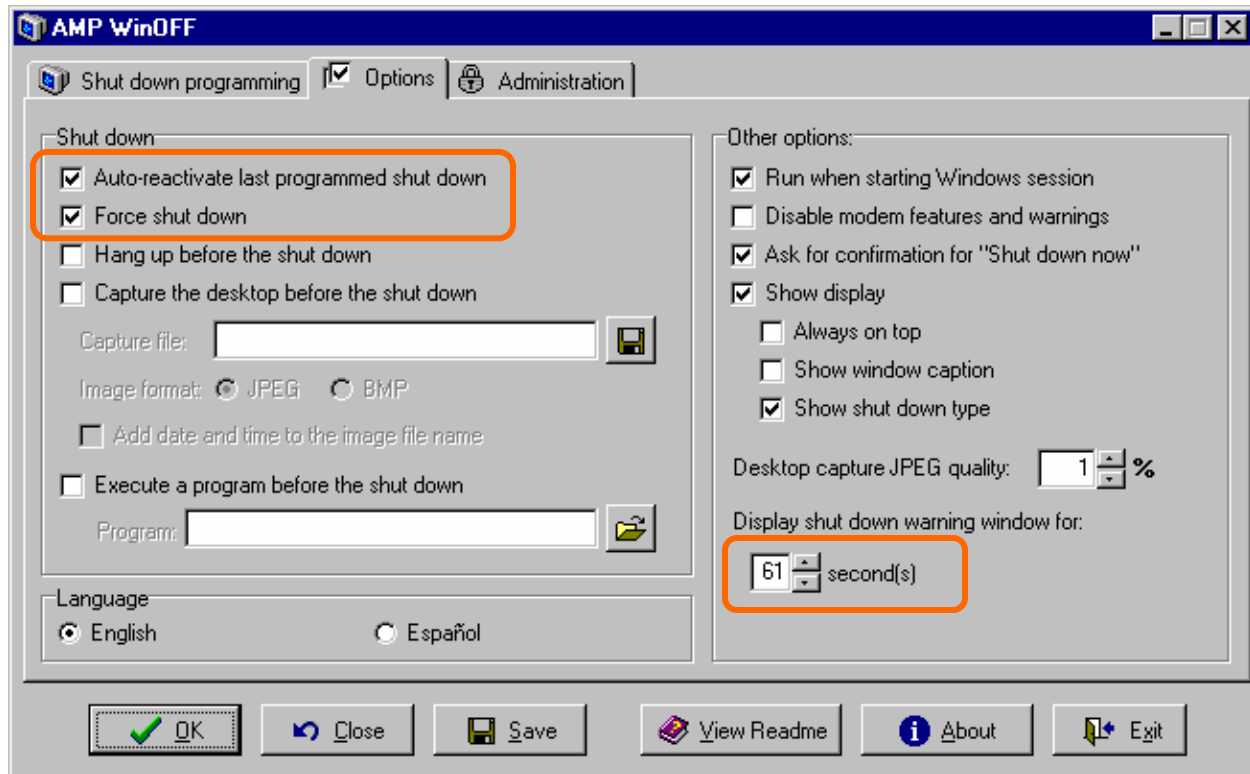

Figure 3-8 WinOFF Options Screen

3.2.6 PC System Uptime Monitor

The System Uptime Monitor is a utility that logs when the system reboots or experiences a power outage. The duration of power outages is logged as well as how long the system has been running for since its last reboot or power failure. The logged outages are displayed in a text window as shown in [Figure 3-9](#). Uptime Monitor is installed in the `C:\uptimemonitor` subdirectory. Uptime Monitor is loaded at boot-time by placing a short-cut to the executable in the Windows *Startup* folder.

3.2.7 PC Scheduling Software

Brewer PC local automated program control and scheduling are required when a Brewer site does not have internet access, and its only means of communication is via modem link. Under these circumstances, a program called *Macro Scheduler* (see [Figure 3-10](#)) is installed to automatically stop the *pcAnywhere* Host program, open *PC Clock* to dial NIST and update Brewer PC's clock with current Universal Time, and finally restart the *pcAnywhere* Host program.

The *Macro Scheduler* installation program places the executable in the standard Program Files folder. *Macro Scheduler* is loaded at boot-time by a short-cut being placed in the Windows *Startup* folder. When *Macro Scheduler* is running, a Cog-Icon is placed in the System Tray.

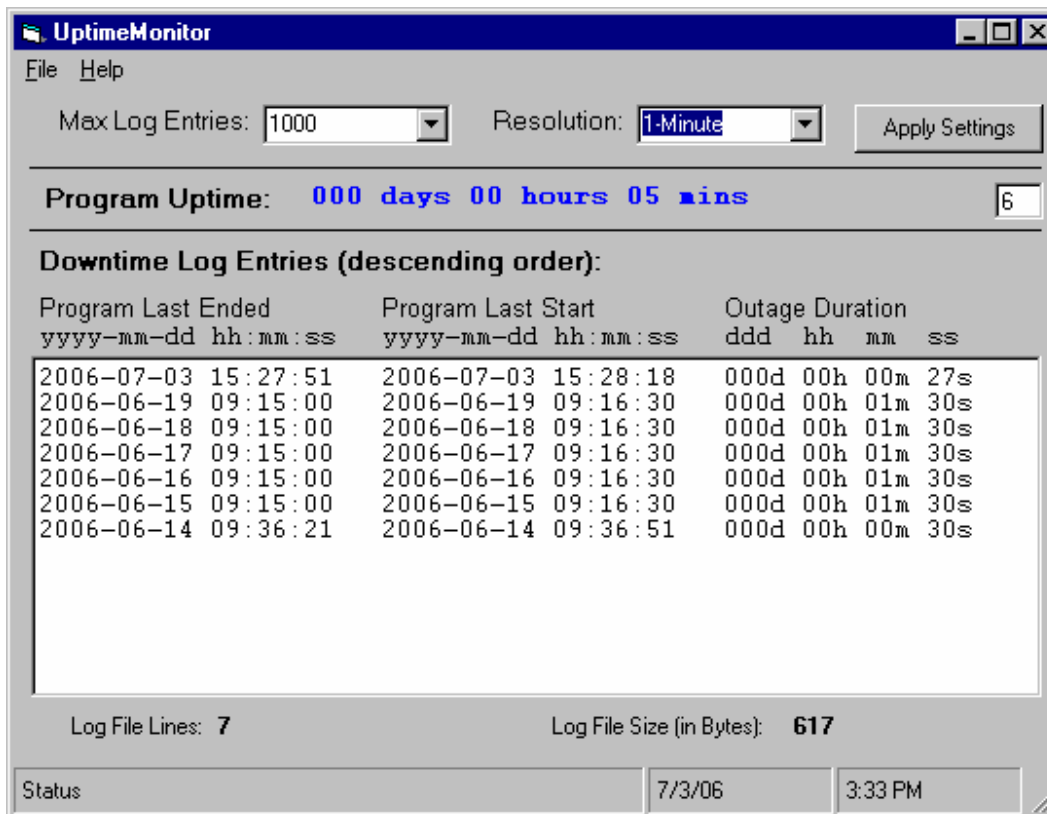

Figure 3-9 System Uptime Monitor Screen

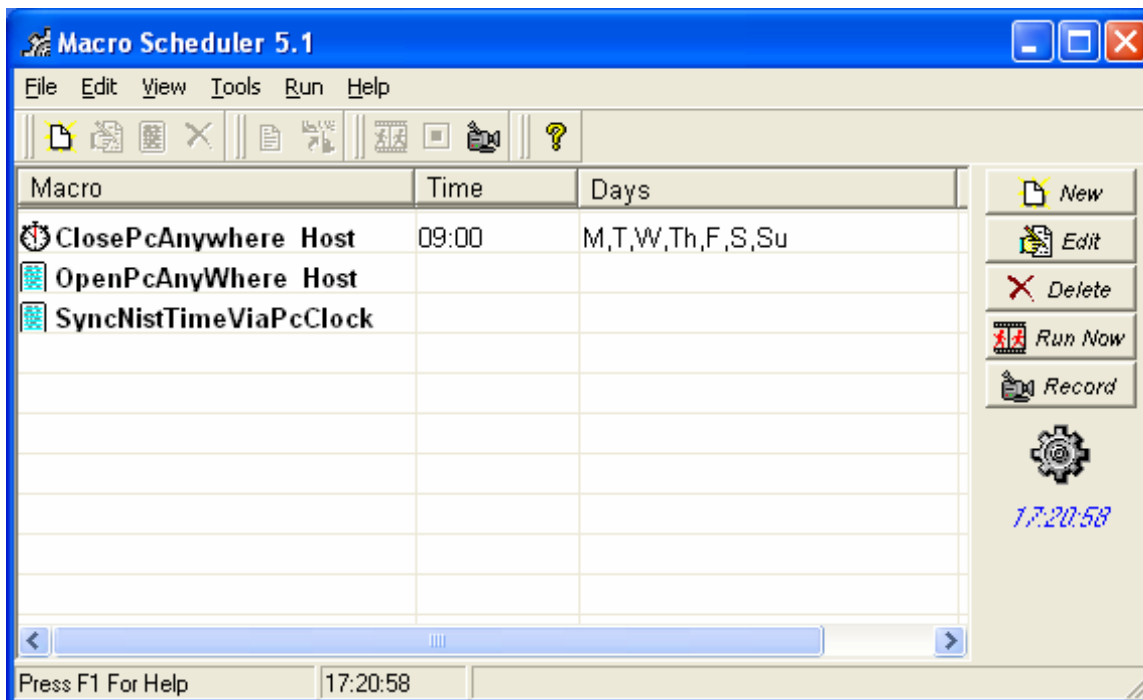

Figure 3-10 Macro Scheduler Software

3.3 Brewer-to-PC Communications Interface

The Brewer Spectrophotometer communicates with the control PC via RS-232 serial communications link. If the distance between the Brewer and PC is more than 25 feet, a RS-485 converter is used to increase data transmission capabilities over longer cable lengths.

3.3.1 RS-232

Each Brewer Instrument has a RS-485 converter installed inside the chassis. When the Brewer is configured for RS-232 communications, the RS-485 converter is by-passed by reconfiguring the wiring harness connected to the RS-485 converter as shown in [Figure 3-11](#).

To enable the RS-485 Converter, the cable (socket connector) with the red, orange, and black wires is connected to J2 on the Brewer Computer CPU card. The socket originally connected to J2 on the CPU card is connected to the plug that connects to the units' four-position terminal block as shown in [Figure 3-12](#)

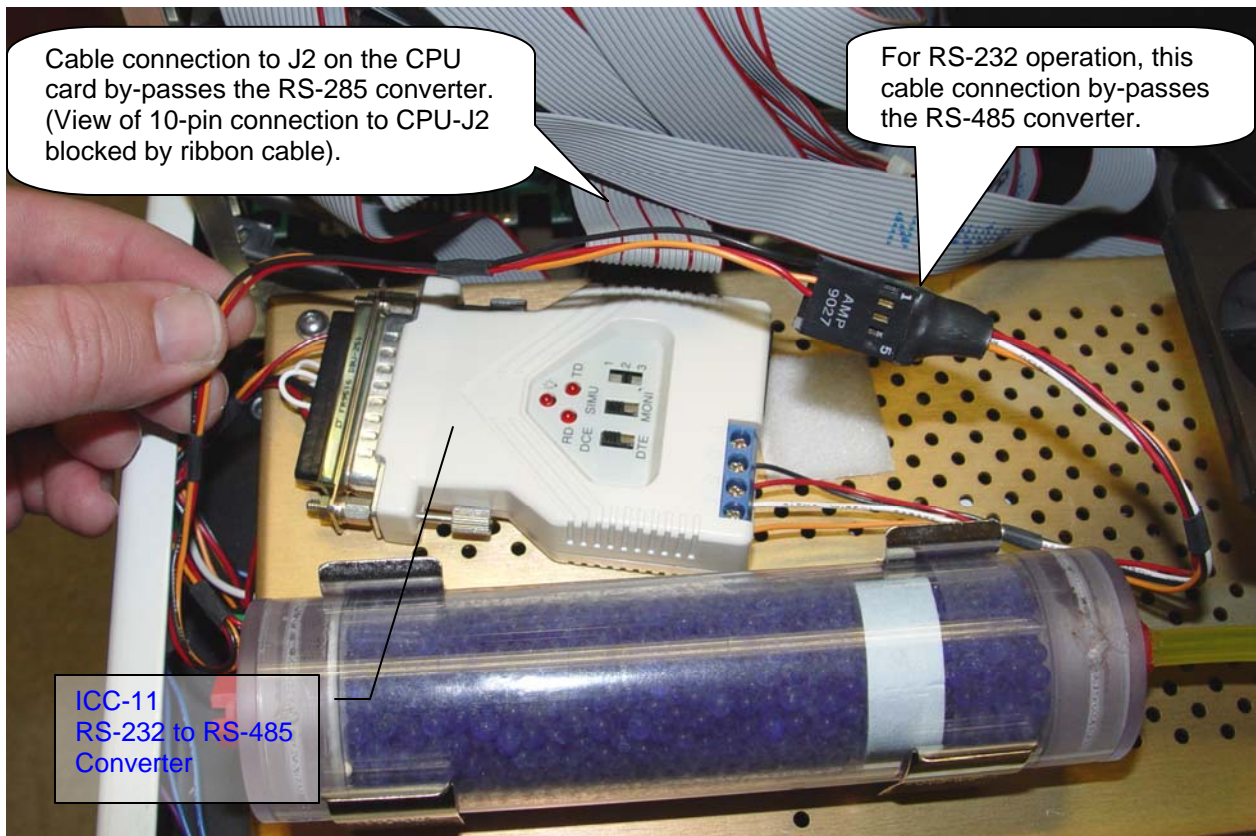

Figure 3-11 RS-485 Converter By-Passed in Brewer Chassis

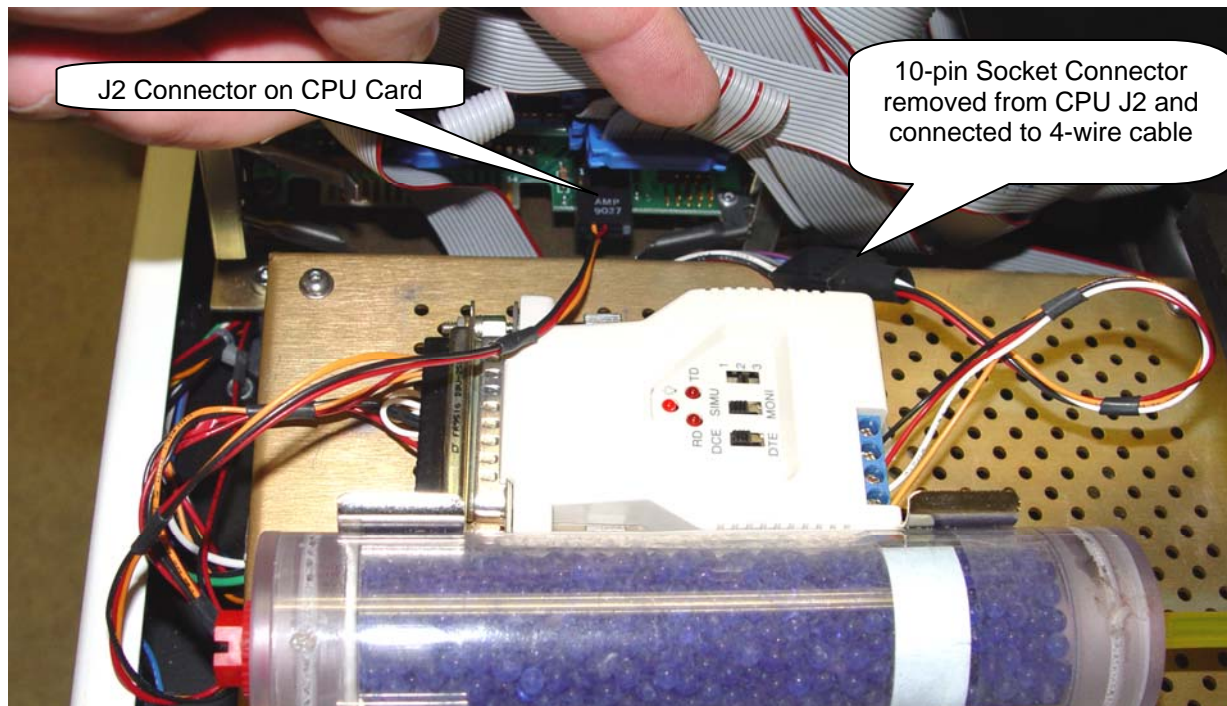

Figure 3-12 RS-485 Converter Connected in the Brewer Chassis

3.3.2 RS-485 Converters

3.3.2.1 ICC-11 RS-232-RS485 Converter

If an ICC-11 is used inside the Brewer Chassis, it draws its power from the DB-25F connector. The required RS-232 hand-shaking signals are looped-back to the ICC-11 via the DB-25F connector. See [Figure 3-13](#) for the wiring diagram of the ICC-11.

If an ICC-11 is connected to the Brewer Control Computer, the ICC-11 will require an external 9 VDC power supply. Depending on the serial port configuration of the Control Computer, gender changers and/or DB-25 to DE-9 adapters may be required to interface the serial port. See [Figure 3-13](#) for the wiring connections required at the Control Computer.

3.3.2.2 IC-485s RS-232-RS-485 Converter

If an IC-485s is used inside the Brewer Chassis, it draws its power from the DB-25F connector. The required RS-232 hand-shaking signals are looped-back to the IC-485s via the DB-25F connector. See [Figure 3-14](#) for the wiring diagram of the IC-485s.

If an IC-485s is connected to the Brewer Control Computer, the IC-485s will require an external 9 VDC power supply. Depending on the serial port configuration of the Control Computer, gender changers and/or DB-25 to DE-9 adapters may be required to interface with the PC serial port. See [Figure 3-14](#) for the wiring connections required at the Control Computer. The IC-485s requires the use of a hand-shaking loop-back adapter as shown in [Figure 3-14](#).

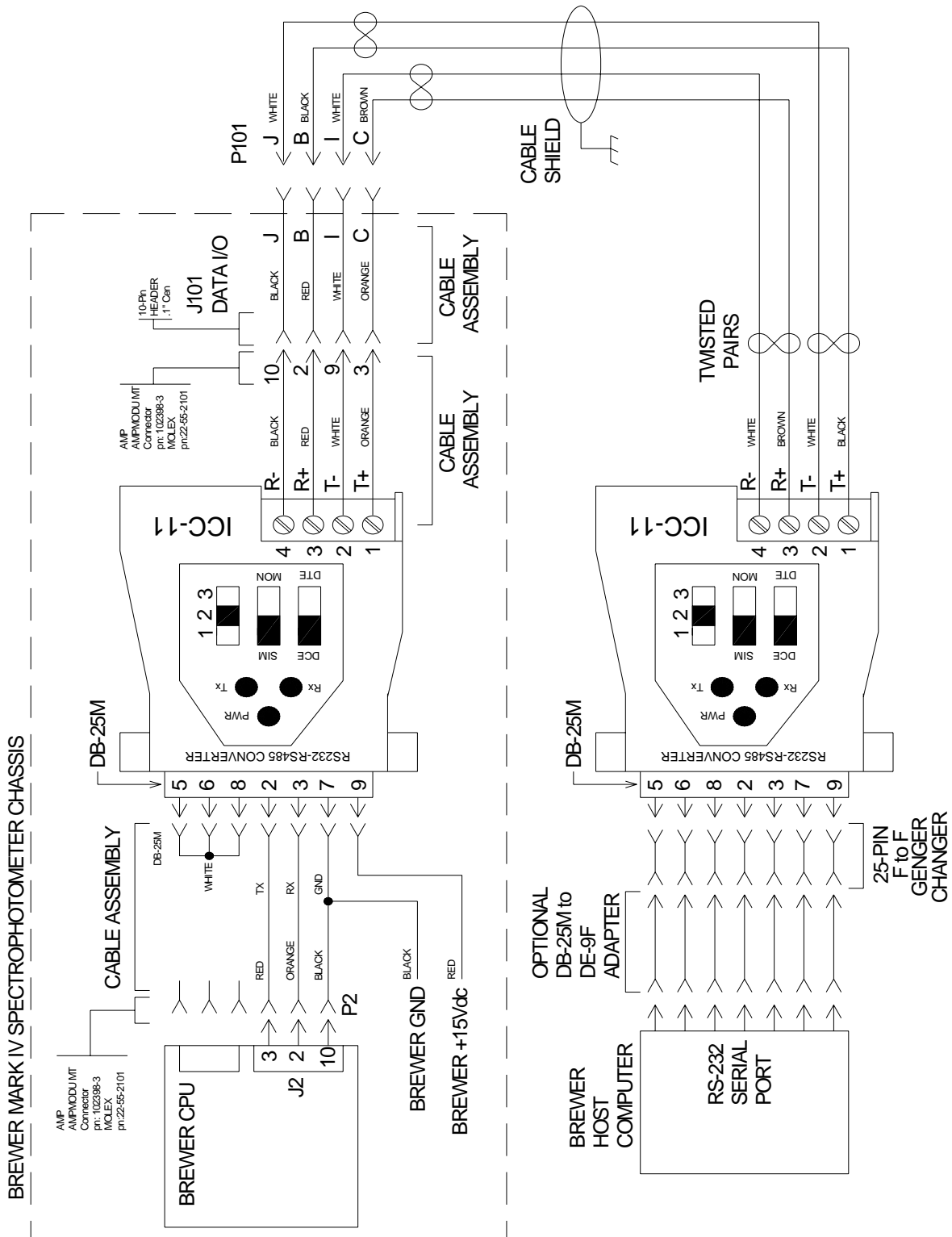

Figure 3-13 ICC-11 RS-485 Converter Wiring Diagram

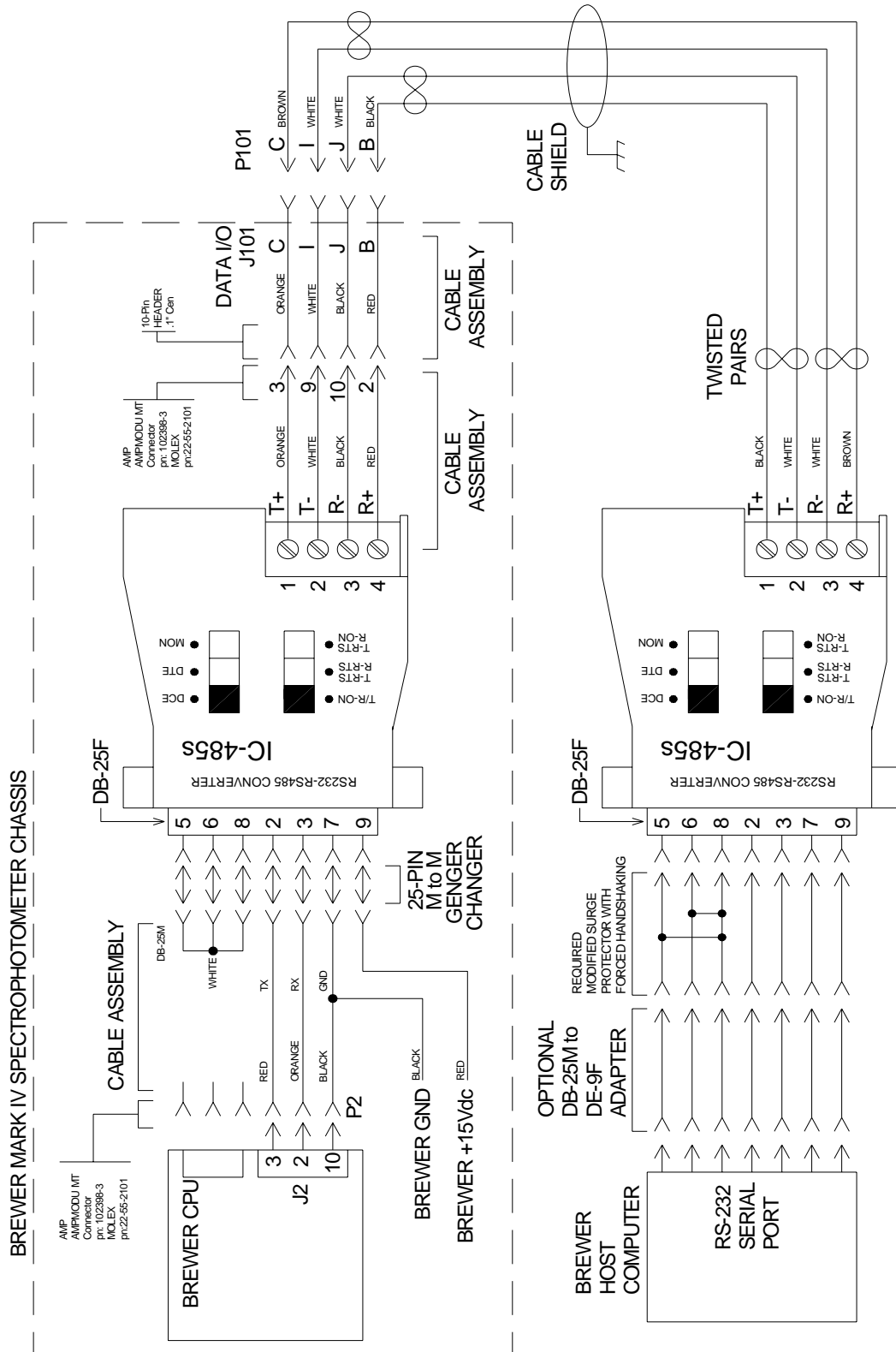

Figure 3-14 IC-485s RS-485 Converter Wiring Diagram

4 Brewer Spectrophotometer Maintenance

The day-to-day maintenance of the Brewer Spectrophotometer is fairly straight forward. The routine procedures include visual inspections and cleaning, checking humidity levels inside the case, changing desiccant bags as required, and periodically calibrating the instrument's tracking with a Sun Sighting Alignment. This section describes each of these tasks.

4.1 Cleaning External UV Dome and Quartz Window

For optimal accuracy, the UV Dome and Quartz Window should be kept free of dust and water spots. Using a mild window or glass cleaner such as Windex and paper towels, clean the UV Dome, Quartz Window and Viewing Window as shown in [Figure 4-1](#). Note any condensation inside the glass. Log the condition of the glass surfaces and the cleaning in the electronic log and site log book.



Figure 4-1 Brewer Routine Glass Cleaning

4.2 Enclosure Cover Removal and Maintenance

Before removing the Brewer enclosure cover, always install the UV Dome Protector as shown in [Figure 4-2](#). To remove the cover, rotate (CCW) the handle on each of the four latches, after the latch has been lifted away from the catch, rotate the latch handle (CW) to the tightened position (see [Figure 4-4](#)). This will prevent the latches from snagging on the catch when the cover is lifted. Lift the cover straight up, keeping the cover level. Once the cover has been removed, examine the weather strip on the inside of the cover. Make sure the weather stripping is seated properly as shown in [Figure 4-3](#). Place the cover flat on the ground (preferably on a clean dry surface) so that it can not tip over. If the latches are hard to turn, apply a drop of light-weight machine oil to each of the latches as shown in [Figure 4-4](#).



Figure 4-2 UV Dome Protector



Figure 4-3 Inside Cover Weather-Seal

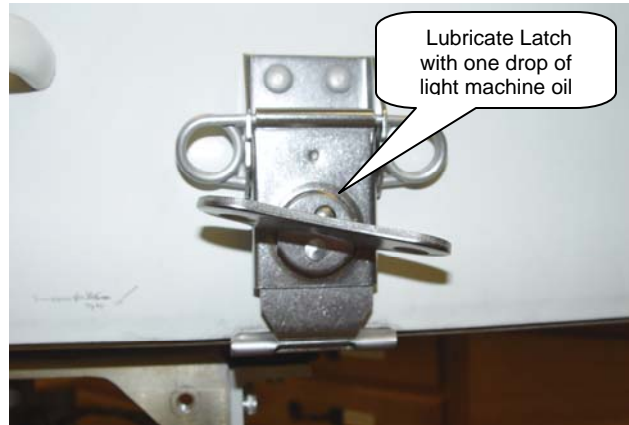

Figure 4-4 Latch Maintenance

4.3 Checking Humidity Indicators

Humidity is the enemy of the Brewer. Prolonged exposure to elevated humidity levels (greater than 20%) inside the Brewer enclosure may degrade performance or cause serious damage the mechanics and optics. The Brewer enclosure has a Humidity Monitor mounted in the Viewing Window that should be checked several times a week (see Figure 4-5). Other indicators of humidity include the Breather Tube located inside the Brewer enclosure (see Figure 4-7), and the Spectrometer Humidity Indicator mounted on the side of spectrometer case (see Figure 4-8). The Breather Tube and Spectrometer Humidity Indicators should be checked when ever there is a need to remove the cover from the Brewer for routine maintenance.

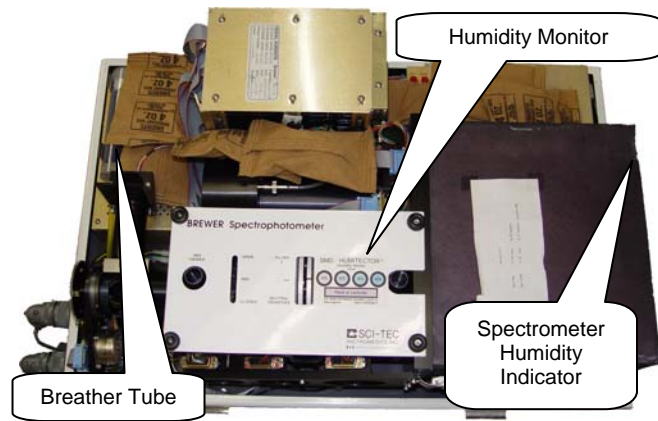

Figure 4-5 Humidity Indicator Locations

4.3.1 Humidity Monitor Strip

The Humidity Monitor is visible through the Viewing Window between Filter Wheel #1 and the Entrance Slit View Tube. The Humidity Indicator's circles change color from Blue to Lavender if the humidity has reached specified levels (see Figure 4-6). If the Humidity inside the Brewer is greater than 20%, follow the Desiccant Pack Replacement Procedure defined in Section 4.4.1. Make log entries noting the humidity indication and any desiccant changes.

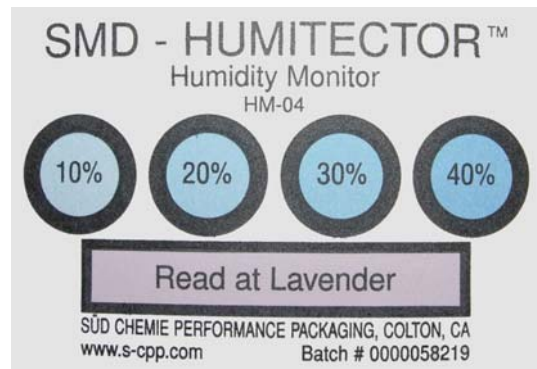

Figure 4-6 Humidity Monitor Strip

4.3.2 Breather Tube Desiccant

The breather tube vents the Brewer enclosure to the outside atmosphere. The desiccant in the breather tube is intended to remove moisture from air drawn into the enclosure by changes in barometric pressure. The desiccant beads inside the breather tube should be dark blue as shown in [Figure 4-7](#). If the beads start to turn pink, the breather tube should be replaced with a freshly dried breather tube. Breather Tube replacement procedure is defined in [Section 4.4.2](#).

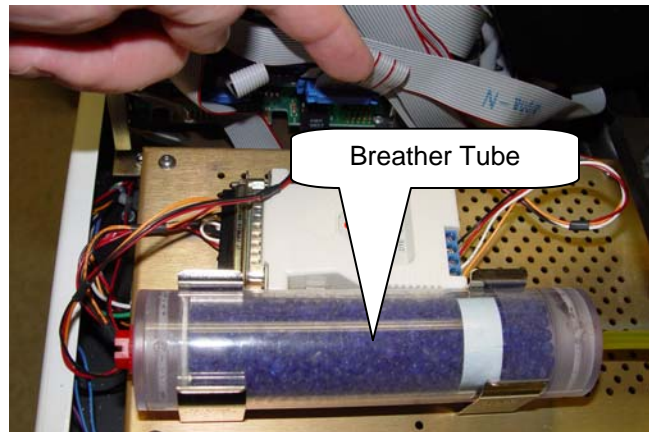

Figure 4-7 Breather Tube Desiccant

4.3.3 Spectrometer Humidity Indicator

The intent of the Spectrometer Humidity Indicator (see [Figure 4-8](#)) is to keep the moisture level down in the spectrometer compartment. The indicator is also a desiccant holder. Under normal circumstances, maintenance of this indicator will be done by NOAA service personnel during scheduled spectrophotometer calibrations.



Figure 4-8 Spectrometer Humidity Indicator

4.4 Desiccants

4.4.1 Changing Desiccant Packs

Reusable desiccant packs are placed inside the Brewer chassis. Six to eight packs may be used, depending on the environment where the Brewer is located. The packs should not obstruct the view of any optics and should be placed away from moving parts such as gears. The preferred location for desiccant packs is shown in [Figure 4-9](#). Replacement desiccant packs must be stored in an air-tight container such as a *Zip-Lock* bag. The **desiccant packs removed from the Brewer should not be discarded** and should be stored in an air-tight *Zip-Lock* bag. Fresh supplies of desiccant packs will be provided by NOAA personnel during scheduled calibration visits.

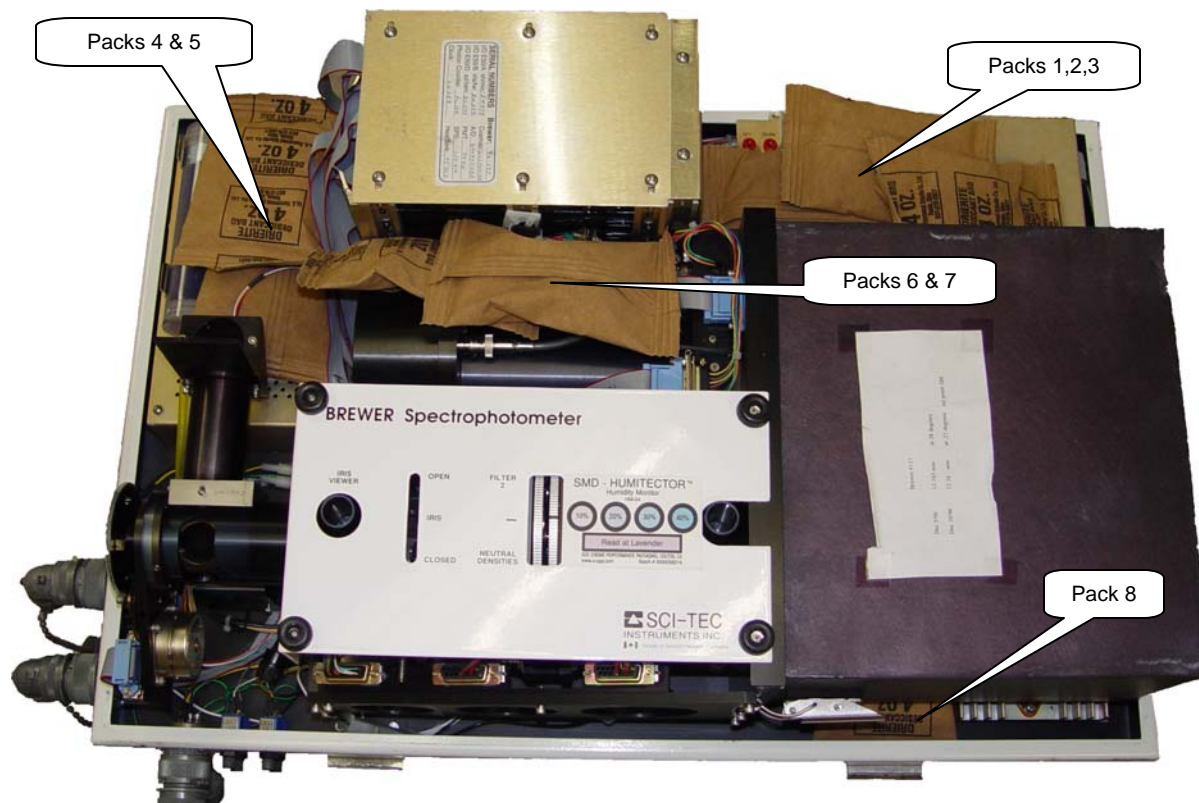

Figure 4-9 Desiccant Pack Locations

4.4.2 Changing Breather Tube Desiccant

To replace the breather tube, remove the tube from the mounting brackets, and unscrew the breather tube from the vent hose. Connect the vent hose to the replacement breather tube and secure the breather tube in the mounting brackets. Note the replacement activity in the electronic log and site log book.

4.5 Sun Sighting Alignment

Accurate measurements depend on the instrument being aligned very accurately to the Sun. Improper alignment, inaccurate computer clock, or inaccurate latitude/longitude, can affect polarization and the consistency of all measurements. This procedure assumes the Brewer's Tracker has been properly aligned towards North and accurately leveled during the installation process.

4.5.1 Procedure

This sun sighting procedure can only be done on a day when the intensity of sun light causes sharp shadow cast.

1. Verify the date and the time on the Brewer Control Computer is set as close as possible to the NIST time standard. Brewer sites that have internet access will have a NIST time program that should keep the time set very accurately.
2. On the Brewer Control Computer (see [Figure 4-10](#)), observe the current mode of operation, if the instrument is currently taking **HG** or **UX** measurements, do NOT interrupt the scan, wait for the scan to complete. Press the HOME key to terminate any measurement except **HG** or **UX** scans.

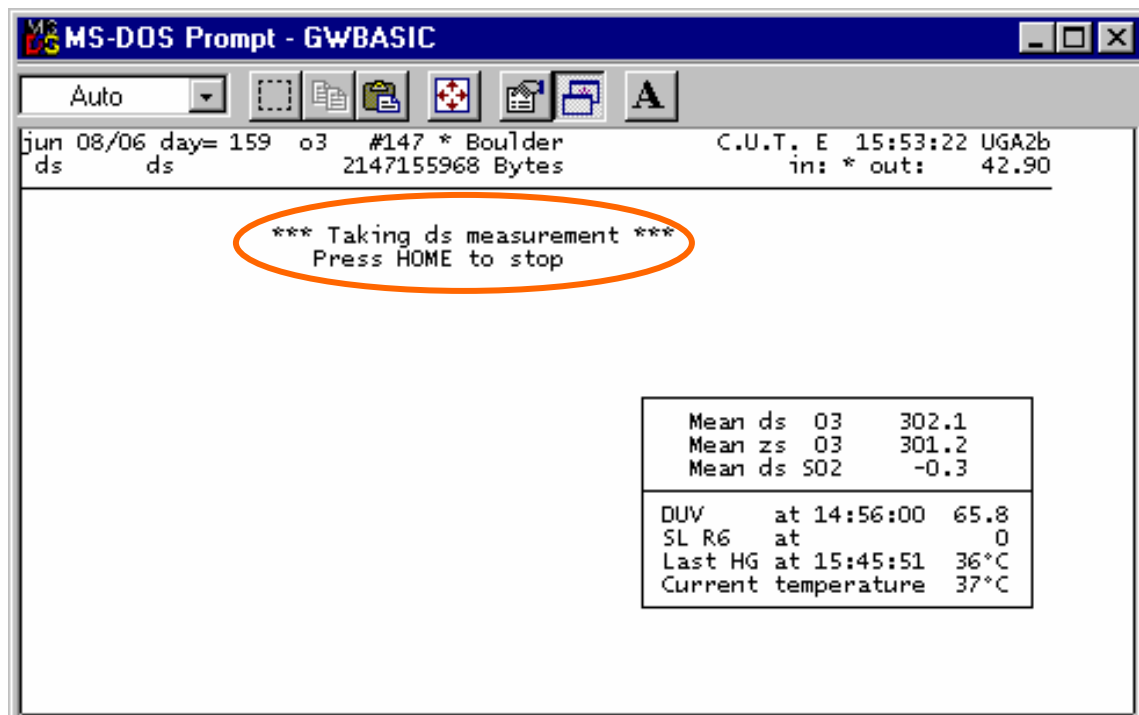

Figure 4-10 Brewer Computer Display

3. Zero the Azimuth Tracker by issuing an **AZ** command. This will cause the tracker to rotate to its zero position (North), and then repositions to track the Sun.
4. Zero the Zenith Prism by issuing a **ZE** command.
5. Enter Sun Sighting mode by issuing a **SI** command. The following screen is displayed (see [Figure 4-11](#)). At this time, the operator should proceed outside to the Brewer instrument.

```

Jun 08/06 day= 159   o3   #132 * Boulder           C.U.T. E 22:45:31 UGA2b
Si      --          2136672540 Bytes             in: * out:  47.56
-----
Keyboard Sighting
Press :-
Crsr up to raise zenith
Crsr down to lower zenith
Crsr right for azimuth clockwise
Crsr left for azimuth counterclockwise
Press CTRL-END when finished
Press K for keyboard
Press R for remote

REMOTE          Horizontal correction:
Step= 5         Old = 7 ;New = 7
                North correction:
                Old = 55 ;New = 55
    
```

Figure 4-11 Brewer SI Command Screen

The Brewer has two sighting tubes located on top of the instrument. The Iris View Tube is used to make course adjustments to the Sun tracking alignment. The Entrance Slit Tube is used to make fine adjustments to the Sun tracking alignment. [Figure 4-12](#) depicts how light enters the Brewer and projects onto the Iris and Entrance Slit Plate. The objective of the alignment procedure is to have the beam of light pass directly through the center of the Iris opening, and have the entrance slit centered horizontally and vertically within the beam of light.

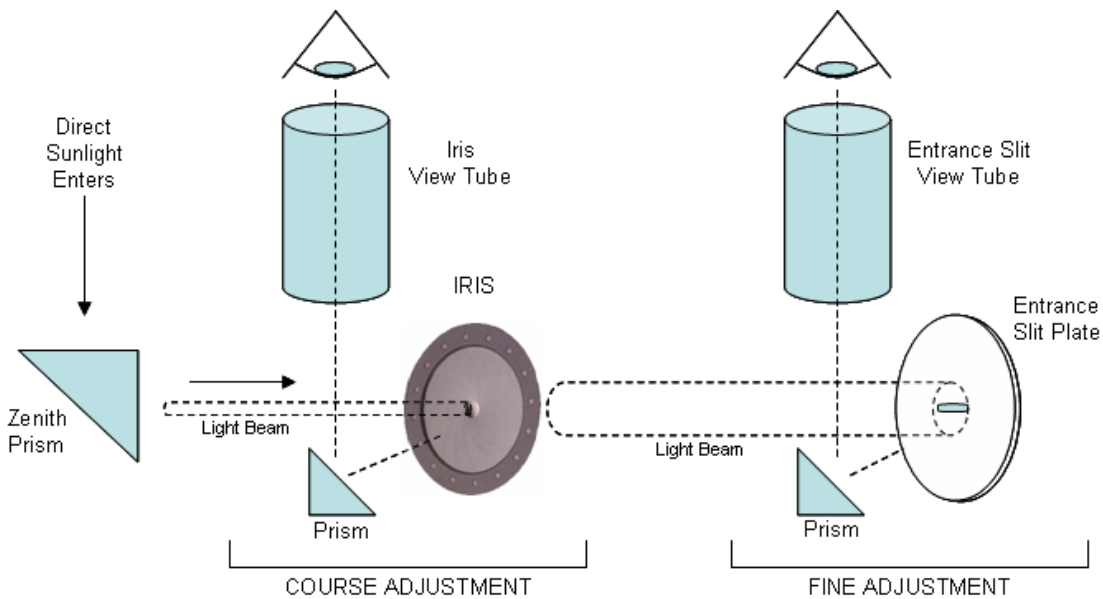

Figure 4-12 Overview of the Brewer Sun Sighting Mechanism

In some instances, the Brewer's alignment may be so far out of tolerance that no image of the Sun is visible in the Iris View Tube. In this case, the operator should employ a manual sighting technique that uses the Brewer's enclosure shape to cast a shadow next to the Quartz Window (refer to [Figure 4-13](#)).

- Press and hold the Brewer's Azimuth **CW** (clockwise) button. The tracker will begin to rotate in small increments. Observe the corner of the Brewer enclosure to the right of the Quartz Window. Continue to hold the CW button until a shadow appears next to the Quartz Window as shown in [Figure 4-13](#).
- Press and release the **CCW** button until brewer rotates counter-clockwise just enough to make the shadow disappear (similar to [Figure 4-14](#)).

Look down through the Iris View Tube (as shown in [Figure 4-16](#)) being careful not to block the sun from the Quartz Window with your shoulder. Use the Zenith UP/DOWN Buttons to attempt to position an image of the Sun on the Iris (see [Figure 4-18](#)).

The Zenith Prism shaft having finite rotation limits (see [Figure 4-15](#)) can be damaged if the operator attempts to rotate the Zenith Prism beyond these limits (-90° to 180°). To prevent possible damage to the Brewer, never manually rotate the Zenith Prism beyond 0° to 90° . Once the Sun's image is visible on the Iris proceed to step 8.



Figure 4-13 Visible shadow caused by Brewer's azimuth alignment being rotated too far in the clockwise (CW) direction



Figure 4-14 Brewer with proper azimuth alignment. No shadow may also indicate azimuth is rotated too far in the counter-clockwise (CCW) direction

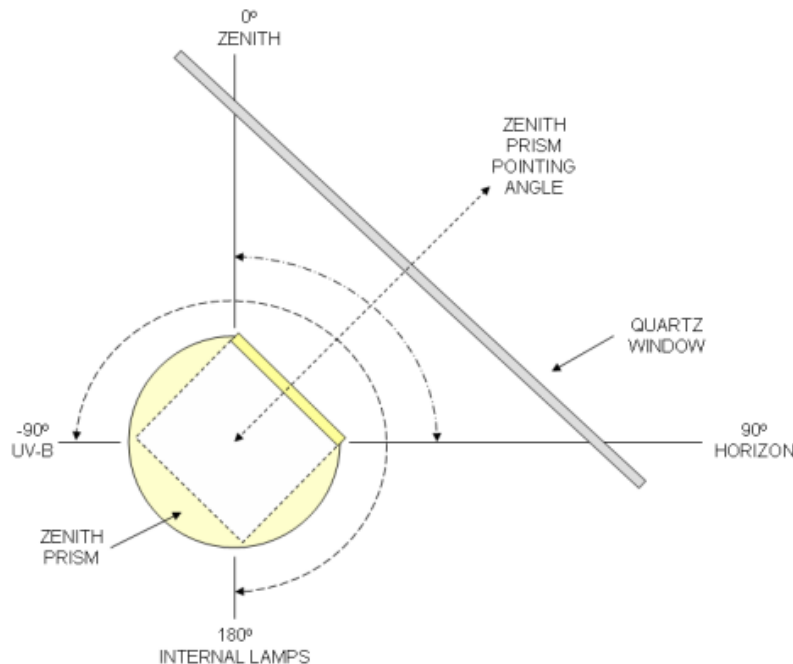

Figure 4-15 Zenith Prism Maximum Rotations

6. Position your body to the right of the Quartz Window, look through the Iris View Tube as shown in [Figure 4-16](#). Make sure not to block the sun from the Quartz Window.
7. Press the UP/DOWN buttons to move the Zenith Prism, press the CC (clock-wise) and CCW (counter clock-wise) buttons to rotate the Tracker. See [Figure 4-17](#) for the orientation of the UP/DOWN and CC/CCW buttons.

If the course-sighting of the instrument is slightly off, the image of the Sun would be projected on the face of the Iris and shown in [Figure 4-18](#). [Figure 4-19](#) shows the image of the Sun properly centered on the opening of the Iris. When the Sun is passing directly through the center of the Iris, there may be a slight orah of light surrounding the Iris opening, or there may be no visible indication of light.

8. Once the course sighting is completed, look down through the Entrance Slit View Tube (the right view tube on top of the Brewer). Once again, be very careful to position your body to the right of the Quartz Window so your shoulder does not block light from entering the Zenith Prism. If the alignment of the instrument is only slightly off, you would see an image similar to the one shown in [Figure 4-20](#). Use the UP/DOWN and CC/CCW buttons move the slit to the horizontal and vertical center of the circle of light and shown in [Figure 4-21](#).



Figure 4-16 Looking through sighting tubes without blocking the Quartz Window from the Sun



Figure 4-17 Locations of Tracker Sighting Adjustment Buttons

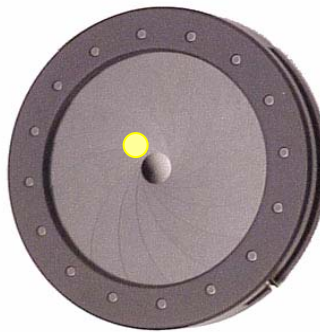

Figure 4-18 Image of Sun improperly aligned on the on face of the Iris

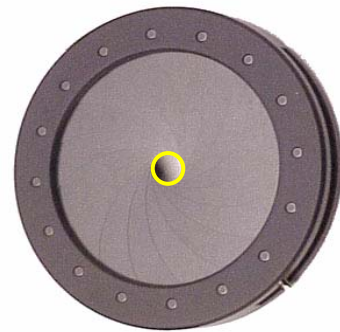

Figure 4-19 Image of Sun properly aligned on the face of the Iris

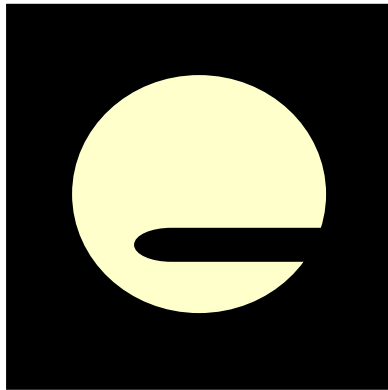

Figure 4-20 Entrance Slit improperly aligned

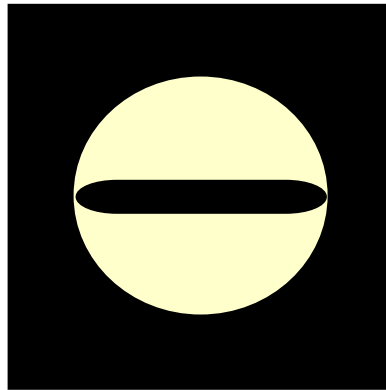

Figure 4-21 Entrance Slit properly aligned

9. Return to the Brewer Control Computer and press **CTRL-END** to end the Sun Sighting mode. Press **Y** to enter the new Horizontal and North Correction values.
10. Restore the Brewer to its automatic continuous schedule by issuing a **SKC <CR>** command. When prompted, enter **EPA96D <CR>** (the name of the Brewer schedule file).

4.5.2 Sun Sighting Troubleshooting

Symptom	Indication of Problem With...
North Correction numbers alternate between higher and lower numbers consistently from morning to afternoon.	Tracker may not be leveled Correctly. Or it may indicate a problem with the instrument, Tracker, or Optical Circuit Board.
Very inconsistent North Correction values from one sighting to another.	Tracker drive mechanism may be slipping.
Inconsistent Horizon Correction values.	Possible Zenith Prism slippage.
Constant drift in both Horizon and North corrections.	Site Latitude and/or Longitude coordinates are incorrect. Or the computer's date or time may not be set correctly.

5 Azimuth Tracker Maintenance

5.1 Tracker Mechanical Inspection

The Tracker/Tripod assembly should be inspected visually for mechanical integrity.

- Verify the tripod is securely fastened to the concrete slab.
- Check for loose nuts/bolts where the Tracker is bolted to the tripod.
- Verify that all four of the brewer head bolts are not loose or missing.
- Check the power and communication interface cables for signs of stress, binding, and serious deterioration.
- Verify that all military-style connectors are tightened (finger tight).

Correct any mechanical problems and log actions in the electronic log and site log book. If cables are damaged significantly, contact Patrick.Disterhoft@noaa.gov for further assistance.

5.2 Tracker Azimuth Wheel Maintenance

The Tracker's azimuth wheel requires periodic cleaning to keep the Brewer accurately tracking the Sun. The azimuth wheel is driven by a friction coupling to a drive shaft. Over time, the wheel and the shaft become dirty and slippage occurs. To clean the azimuth wheel, follow the procedure below:

1. On the Brewer Control Computer (see [Figure 5-1](#)), observe the current mode of operation, if the instrument is currently taking **HG** or **UX** measurements, do NOT interrupt the scan, wait for the scan to complete. Press the HOME key to terminate any measurement except **HG** or **UX** scans.

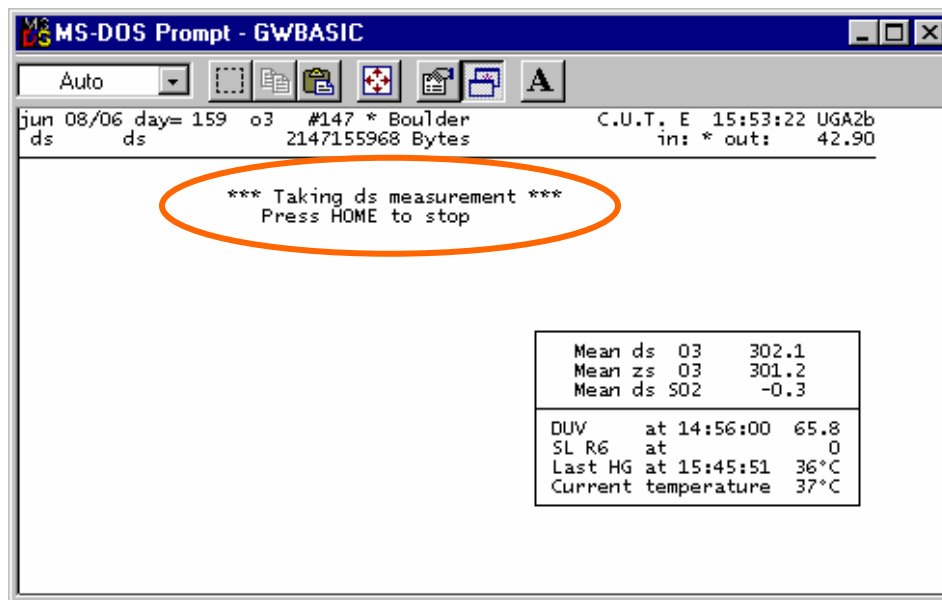

Figure 5-1 Brewer Computer Display

Azimuth Tracker Maintenance

2. Proceed out the Brewer instrument. Turn off power to the Tracker by pressing the power button on the lower side of the Tracker. The power to the Brewer Spectrophotometer can remain on.

3. Remove the Tracker's cover panel(s) by removing four 5/32" hex-head bolts. When the tracker's cover is removed, check the four captive-nuts in the inside of the panel (see Figure 5-2). Rotate the captive-nuts (CW) until they rotate freely and base of the hex-head bolts. This will ensure that the captive-nuts do not bind against the Tracker housing when the cover is re-attached.

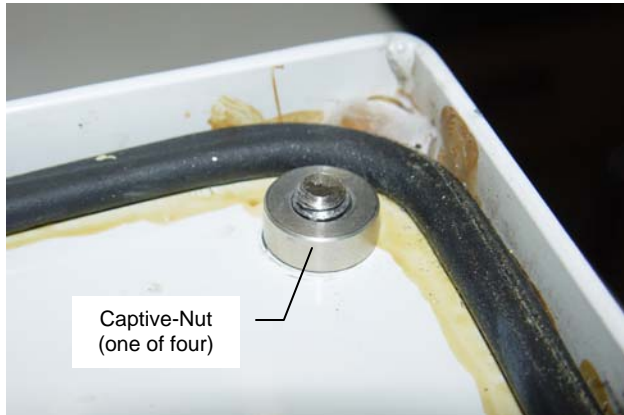

Figure 5-2 Tracker Cover Plate Captive-Nuts

4. To clean the entire azimuth wheel the Tracker will need to be rotated manually. Before continuing, note the relative orientation of the Tracker's azimuth, use this position as a reference-marker. Return the Tracker to this position once the cleaning is completed. The Tracker should be able to be manually rotated up to 180° left or right from the current azimuth. If the Tracker is rotated too far in one direction, the tension cable on the Over-Rotation Protection Switch will trip the internal toggle switch (see Section 5.3 for information about the Over-Rotation Protection Switch).

5. Using a paper towel and mild cleaner such as *Formula 409* or *Windex*, clean the edge of the full circumference of the aluminum azimuth wheel and stainless steel drive shaft as shown in Figure 5-3. The edge of the wheel and shaft should be smooth and shiny after cleaning is completed.

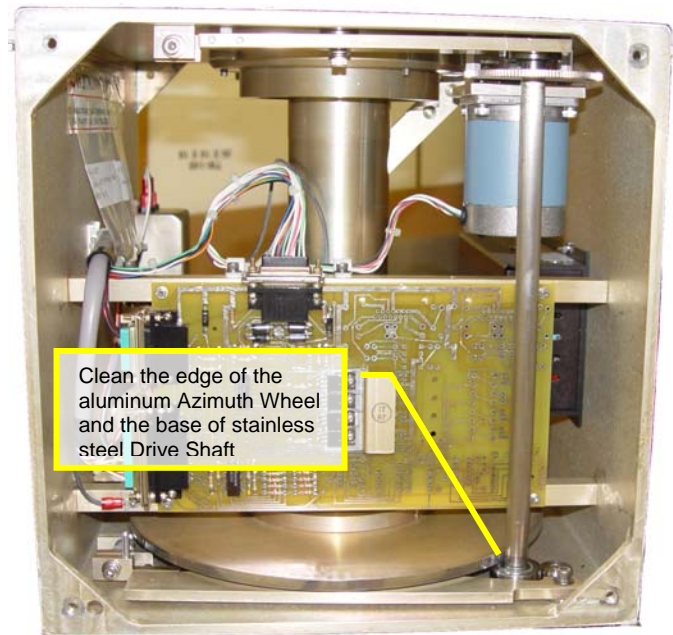

Figure 5-3 Tracker Azimuth Wheel Cleaning

6. Manually rotate the tracker to its original azimuth position. Install Tracker cover panels, and press the Power button to restore power the Tracker.

Azimuth Tracker Maintenance

7. Return to the Brewer Control Computer. Zero the Azimuth Tracker by issuing an **AZ** command. This will cause the tracker to rotate to its zero position (North), and then repositions to track the Sun.
8. Restore the Brewer to its automatic continuous schedule by issuing a **SKC** <CR> command. When prompted, enter **EPA96D** <CR> (the name of the Brewer schedule file).

5.3 Tracker Over-Rotation Protection Switch

Under certain circumstances such as a power-outage or brown-out, the Brewer can lose track of where it thinks the azimuth wheel is positioned. The Tracker Over-Rotation Protection Switch prevents the Brewer from damaging cables due cable binding. Inside the Tracker housing, a toggle switch is mounted on a fixed bracket. A cable attaches the Trackers center axle to the toggle switch lever. If the axle rotates too far the tension on the cable will flip the toggle switch which in turn kills power to the tracker.

During routine Tracker maintenance, the connections of the cable linking the Tracker Axle to the Over-Rotation switch should be inspected. The cable is connected to the toggle switch with fishing line. It is feasible for the knot in the fishing line to come undone. [Figure 5-4](#) depicts how the tension wire connects to the Over-Rotation Protection Switch, and the switch in its normal (operational) position.

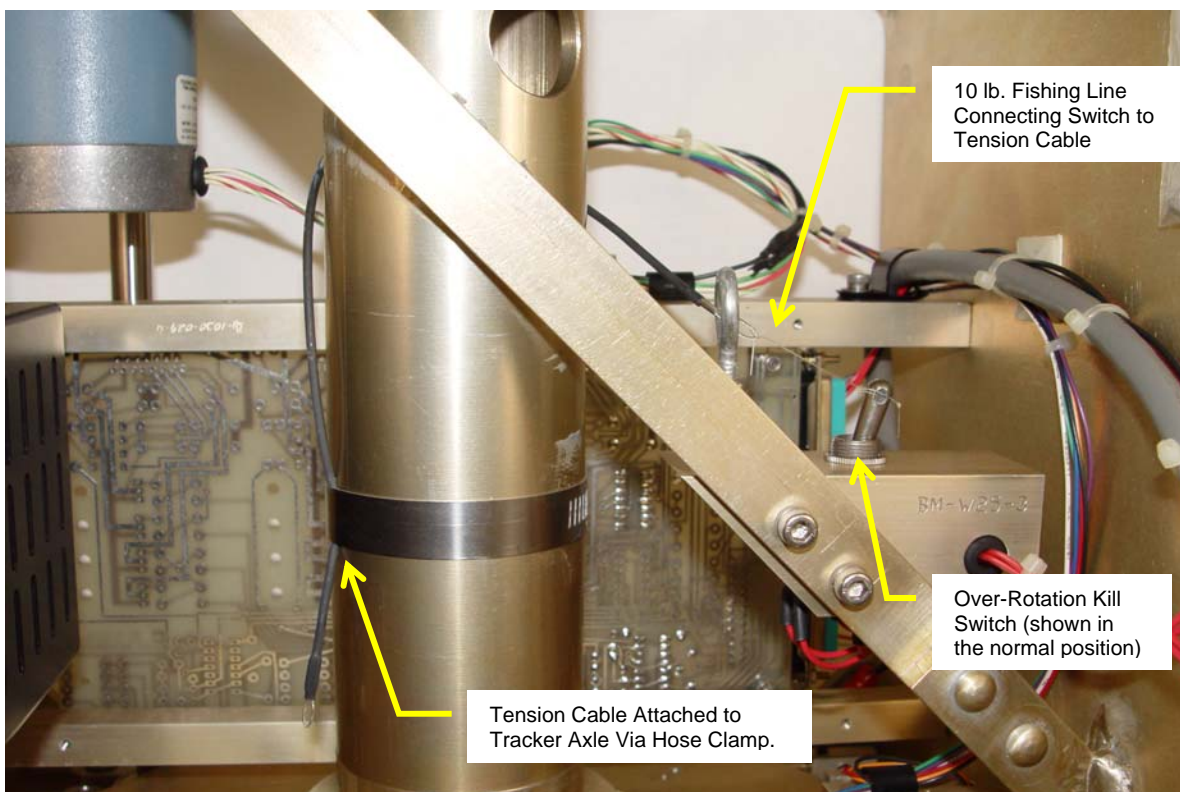

Figure 5-4 Tracker Over-Rotation Protection Switch

This page intentionally left blank

Day of Year Calendar (Perpetual)

Day	JAN	FEB	MAR	APR	MAY	JUN	JUL	AUG	SEP	OCT	NOV	DEC	Day
	1	2	3	4	5	6	7	8	9	10	11	12	
1	001	032	060	091	121	152	182	213	244	274	305	335	1
2	002	033	061	092	122	153	183	214	245	275	306	336	2
3	003	034	062	093	123	154	184	215	246	276	307	337	3
4	004	035	063	094	124	155	185	216	247	277	308	338	4
5	005	036	064	095	125	156	186	217	248	278	309	339	5
6	006	037	065	096	126	157	187	218	249	279	310	340	6
7	007	038	066	097	127	158	188	219	250	280	311	341	7
8	008	039	067	098	128	159	189	220	251	281	312	342	8
9	009	040	068	099	129	160	190	221	252	282	313	343	9
10	010	041	069	100	130	161	191	222	253	283	314	344	10
11	011	042	070	101	131	162	192	223	254	284	315	345	11
12	012	043	071	102	132	163	193	224	255	285	316	346	12
13	013	044	072	103	133	164	194	225	256	286	317	347	13
14	014	045	073	104	134	165	195	226	257	287	318	348	14
15	015	046	074	105	135	166	196	227	258	288	319	349	15
16	016	047	075	106	136	167	197	228	259	289	320	350	16
17	017	048	076	107	137	168	198	229	260	290	321	351	17
18	018	049	077	108	138	169	199	230	261	291	322	352	18
19	019	050	078	109	139	170	200	231	262	292	323	353	19
20	020	051	079	110	140	171	201	232	263	293	324	354	20
21	021	052	080	111	141	172	202	233	264	294	325	355	21
22	022	053	081	112	142	173	203	234	265	295	326	356	22
23	023	054	082	113	143	174	204	235	266	296	327	357	23
24	024	055	083	114	144	175	205	236	267	297	328	358	24
25	025	056	084	115	145	176	206	237	268	298	329	359	25
26	026	057	085	116	146	177	207	238	269	299	330	360	26
27	027	058	086	117	147	178	208	239	270	300	331	361	27
28	028	059	087	118	148	179	209	240	271	301	332	362	28
29	029		088	119	149	180	210	241	272	302	333	363	29
30	030		089	120	150	181	211	242	273	303	334	364	30
31	031		090		151		212	243		304		365	31
Day	JAN	FEB	MAR	APR	MAY	JUN	JUL	AUG	SEP	OCT	NOV	DEC	DAY

Day of Year Calendar (Leap Years)

Day	JAN 1	FEB 2	MAR 3	APR 4	MAY 5	JUN 6	JUL 7	AUG 8	SEP 9	OCT 10	NOV 11	DEC 12	Day
1	001	032	061	092	122	153	183	214	245	275	306	336	1
2	002	033	062	093	123	154	184	215	246	276	307	337	2
3	003	034	063	094	124	155	185	216	247	277	308	338	3
4	004	035	064	095	125	156	186	217	248	278	309	339	4
5	005	036	065	096	126	157	187	218	249	279	310	340	5
6	006	037	066	097	127	158	188	219	250	280	311	341	6
7	007	038	067	098	128	159	189	220	251	281	312	342	7
8	008	039	068	099	129	160	180	221	252	282	313	343	8
9	009	040	069	100	130	161	191	222	253	283	314	344	9
10	010	041	080	101	131	162	192	223	254	284	315	345	10
11	011	042	071	102	132	163	193	224	255	285	316	346	11
12	012	043	072	103	133	164	194	225	256	286	317	347	12
13	013	044	073	104	134	165	195	226	257	287	318	348	13
14	014	045	074	105	135	166	196	227	258	288	319	349	14
15	015	046	075	106	136	167	197	228	259	289	320	350	15
16	016	047	076	107	137	168	198	229	260	290	321	351	16
17	017	048	077	108	138	169	199	230	261	291	322	352	17
18	018	049	078	109	139	170	200	231	262	292	323	353	18
19	019	050	079	110	140	171	201	232	263	293	324	354	19
20	020	051	080	111	141	172	202	233	264	294	325	355	20
21	021	052	081	112	142	173	203	234	265	295	326	356	21
22	022	053	082	113	143	174	204	235	266	296	327	357	22
23	023	054	083	114	144	175	205	236	267	297	328	358	23
24	024	055	084	115	145	176	206	237	268	298	329	359	24
25	025	056	085	116	146	177	207	238	269	299	330	360	25
26	026	057	086	117	147	178	208	239	270	300	331	361	26
27	027	058	087	118	148	179	209	240	271	301	332	362	27
28	028	059	088	119	149	180	210	241	272	302	333	363	28
29	029	060	089	120	150	181	211	242	273	303	334	364	29
30	030		090	121	151	182	212	243	274	304	335	365	30
31	031		091		152		213	244		305		366	31
Day	JAN	FEB	MAR	APR	MAY	JUN	JUL	AUG	SEP	OCT	NOV	DEC	DAY

NOAA/EPA Brewer Network Site Health and Status Check List

Site Name:		Date/Time:	
Brewer Serial #:		Operator:	

Daily System Checks

Completed	Task Description	Results or Comments
<input type="checkbox"/>	Verify Brewer CUT (Coordinated Universal Time) is within several seconds of the NIST Time Standard. Refer to Section 2.2.1 of the Site Operators Hand Book.	
<input type="checkbox"/>	Verify Brewer Schedule is running. Record the Schedule Name and Brewer Software Version.	Schedule Name: _____ Brewer SW Version: _____
<input type="checkbox"/>	Clean UV Dome and Quartz Window with paper towel and window cleaner.	
<input type="checkbox"/>	Verify and record the Humidity Indicator Value. If Humidity is greater than 20% refer to Desiccant Replacement in Section 4.4 of the Site Operators Handbook.	Humidity Value: _____ ____ Desiccant Bags Replaced ____ Breather Tube Desiccant Cartridge Replaced
<input type="checkbox"/>	Verify Brewer is tracking the Sun.	
<input type="checkbox"/>	Verify the cables are not stressed or wrapped tightly around the Tracker/Tripod.	

Brewer Sun Sighting (Weekly)

Completed	Task Description	Results												
<input type="checkbox"/>	Perform the Sun Sighting Procedure defined in Section 4.5 of the Site Operators Handbook.	<table border="1" style="width: 100%; border-collapse: collapse; margin-left: auto; margin-right: auto;"> <thead> <tr> <th colspan="2" style="text-align: center;">Horizon Correction</th> <th colspan="2" style="text-align: center;">North Correction</th> </tr> <tr> <th style="text-align: center;">Old Value</th> <th style="text-align: center;">New Value</th> <th style="text-align: center;">Old Value</th> <th style="text-align: center;">New Value</th> </tr> </thead> <tbody> <tr> <td style="height: 20px;"></td> <td></td> <td></td> <td></td> </tr> </tbody> </table>	Horizon Correction		North Correction		Old Value	New Value	Old Value	New Value				
Horizon Correction		North Correction												
Old Value	New Value	Old Value	New Value											

Tracker Inspection and Maintenance (Bi-Monthly)

Completed	Task Description	Results or Comments				
<input type="checkbox"/>	Perform the Track Steps Per Revolution Test defined in Section 5 of the Site Operators Handbook.	<table border="1" style="width: 100%; border-collapse: collapse; margin-left: auto; margin-right: auto;"> <tr> <td style="text-align: center;">Previous SR Value:</td> <td style="width: 100px;"></td> </tr> <tr> <td style="text-align: center;">Latest SR Value:</td> <td></td> </tr> </table>	Previous SR Value:		Latest SR Value:	
Previous SR Value:						
Latest SR Value:						
<input type="checkbox"/>	Inspect and Clean the Tracker Friction Wheel as shown in Section 5 of the Site Operators Handbook.	Condition of Wheel and shaft:				
<input type="checkbox"/>	Inspect the Condition of the Rotation Protection Switch inside the Tracker Case. Verify Cable is attached securely.	Condition of Switch and Cable:				

Other Comments or Notes:
