

H  
QC  
851  
.U6  
T32  
no. 87-2

NOAA Techniques Development Laboratory  
Computer Program NWS TDL CP 87-2



PB 88-1 25570

---

## AFOS - ERA FORECAST VERIFICATION

Silver Spring, Md.  
July 1987

---

**U.S. DEPARTMENT OF  
COMMERCE**

National Oceanic and  
Atmospheric Administration

National Weather  
Service

## PREFACE

The Techniques Development Laboratory's (TDL's) computer program (CP) series is a subset of TDL's technical memorandum series. The CP series documents computer programs written at TDL primarily for the Automation of Field Operations and Services (AFOS) computers.

The format for the series follows that given in the AFOS Handbook 5, Reference Handbook, Volume 6: Applications Programs, Part 1: Policy and Procedures, published by the Office of Technical Services/AFOS Operations Division.

### NOAA Techniques Development Laboratory Computer Program NWS TDL

- CP 83-1 Cross Sectional Analysis of Wind Speed and Richardson Number. Gilhousen, Kemper, and Vercelli, May 1983. (PB83 205062)
- CP 83-2 Simulation of Spilled Oil Behavior in Bays and Coastal Waters. Hess, October 1983. (PB84 122597)
- CP 83-3 AFOS-Era Forecast Verification. Heffernan, Newton, and Miller, October 1983. (PB84 129303)
- CP 83-4 AFOS Monitoring of Terminal Forecasts. Vercelli, December 1983.
- CP 83-5 Generalized Exponential Markov (GEM) Updating Procedure for AFOS. Herrmann, December 1983.
- CP 84-1 AFOS Display of MDR Data on Local Map Background. Newton, July 1984.
- CP 84-2 AFOS Surface Observation Decoding. Perrotti, September 1984.
- CP 84-3 AFOS-Era Forecast Verification. Miller, Heffernan, and Ruth, September 1984.
- CP 85-1 AFOS Monitoring of Terminal Forecasts. Vercelli and Norman, May 1985.
- CP 85-2 AFOS Terminal Forecast Decoding. Vercelli, Norman, and Heffernan, October 1985.
- CP 85-3 AFOS-Era Forecast Verification. Ruth, Miller, and Heffernan, October 1985.
- CP 87-1 AFOS Terminal Aerodrome Forecast Formatting. Wantz and Eggers, July 1987.

H  
QC  
851  
.06  
T32  
no. 87-2

NOAA Techniques Development Laboratory  
Computer Program NWS TDL CP 87-2

# AFOS - ERA FORECAST VERIFICATION

David P. Ruth and Christine L. Alex

Techniques Development Laboratory  
Silver Spring, Md.  
July 1987

LIBRARY  
MAY 2 - 1989  
N.O.A.A.  
U.S. Dept. of Commerce

UNITED STATES  
DEPARTMENT OF COMMERCE  
Secretary of Commerce

National Oceanic and  
Atmospheric Administration  
Anthony J. Callo, Under Secretary

National Weather Service  
Richard E. Hallgren  
Assistant Administrator



TABLE OF CONTENTS

	Page
1. Introduction	1
2. Methodology and Software Structure	1
A. VERCREAT	2
B. VERIFY	3
3. Data Format	7
4. Procedures	8
A. VERCREAT	8
B. Manually Entered Forecasts	8
C. VERIFY	8
D. Quality Control	9
5. Cautions	10
6. References	10
7. Program Information and Procedures for Installation and Execution	11
I. Initialization Program for Local AFOS-era Forecast Verification Software	11
II. Collation Program for Local AFOS-era Forecast Verification Software	14
8. Tables	19
9. Figures	29
Appendix I. Description of VERccc File	43
A. Station/Cycle Information	43
B. Max/Min Temperature	43
C. 12-h PoP	44
D. Precipitation Type	44
E. 12-h Snow Amount	45
F. Cloud Amount	45
G. Ceiling Height	45
H. Visibility	46
I. Wind Direction and Speed	46
Appendix II. VERIFY Error Conditions	47

## AFOS-ERA FORECAST VERIFICATION

David P. Ruth and Christine L. Alex

### 1. INTRODUCTION

In 1983, the National Weather Service (NWS) implemented a national forecast verification system which utilizes the processing and communication capabilities of the Automation of Field Operations and Services (AFOS) system. This AFOS-era forecast verification (AEV) system is an integral part of the National Verification Plan (NWS, 1982a) and replaced two existing national verification programs (NWS, 1982b and NWS, 1973). Local and guidance forecasts of public and aviation elements are verified for two forecast cycles per day. The AEV system is designed to collect and collate forecasts and observations; to provide a local, quality controlled database; to transmit data to a central site; to provide a permanent central archive; and to produce local, regional, and national summaries. Fig. 1 shows an overview of this system. Functions are performed at two levels. At the (local) Weather Service Forecast Office (WSFO) level, forecasts and observations are collected and collated, archived for local use, and transmitted to a central site for use in national summaries. At the national level, the data sent from WSFO's are collected and archived. National summaries are produced semiannually by the Techniques Development Laboratory (TDL) in conjunction with the Office of Meteorology.

The software described here, which is implemented at WSFO's, creates and maintains the local database of collated forecasts and observations. It also transmits the locally collected forecasts and observations to NMC. The design of the local, long-term archive and the production of local summaries can be adjusted to suit local needs. Software to perform these functions has been developed at the regional and local levels and is not part of this package (see Barker, 1987, for an example).

This publication, TDL CP 87-2, supersedes the publications TDL CP 83-3, TDL CP 84-3, and TDL CP 85-3, which are now obsolete.

### 2. METHODOLOGY AND SOFTWARE STRUCTURE

The local AEV software is designed to extract the forecasts and observations for verification from the AFOS products automatically at the local (WSFO) level. All guidance (Model Output Statistics) forecasts and observations can be collected without manual effort. Some local forecasts, however, cannot be extracted from the forecast products; instead, these forecasts are manually entered into an AFOS product (Manually Entered Forecasts) from which the software collects them automatically. Table 1 shows the forecast elements selected for verification. Forecasts which must be manually entered are indicated. The projection times given are in relation to model run time (i.e., 0000 or 1200 GMT) for public elements, and in relation to the beginning of a scheduled terminal forecast (FT) valid period (e.g., 0900 GMT or 1800 GMT when standard time is in effect in the Eastern Time Zone) for aviation elements. In this document, we use "FT valid time" to mean the beginning of an FT valid period. A more detailed description of the forecasts and their verifying observations is given in Appendix I.

The local AEV software is composed of two programs: VERCREAT and VERIFY. VERCREAT is run just once at initialization time and defines which stations in the WSFO area are being verified. VERIFY is run twice daily to collect the forecasts and observations. It collates the forecasts of the past 5 days with the verifying observations, and it builds two AFOS products (Public Verification Matrix and Aviation Verification Matrix) and an RDOS disk file (VERccc) containing this information. The PVM and AVM can be quality controlled via the AFOS message composition feature. The RDOS disk file can be accessed by software developed locally or regionally for generating statistics. VERIFY also prepares and transmits to NMC matched sets of forecasts and observations that have been locally quality controlled. Fig. 2 illustrates the data flow for the local AEV software.

The AEV software is designed to be run twice a day: once for early morning (0000 GMT cycle) forecasts and once for evening (1200 GMT cycle) forecasts. Each cycle has a corresponding FT valid time. If a forecast cycle or cycles have been missed, the software allows processing of those cycles by searching back in the database for forecasts and verifying observations. Even if many previous cycles have been missed, the software has the flexibility to process the current cycle without necessarily including the missed cycles.

#### A. VERCREAT

VERCREAT is run once at the WSFO's Dasher to initialize three RDOS disk files for VERIFY. VERCREAT interactively requests from the user the name of the local WSFO followed by the stations to be verified. A maximum of 12 stations per WSFO is allowed. The first two stations in the list should be those stations that are participating in the national verification program. The software to produce local summaries (Barker, 1987) accesses up to 12 stations' data. The user is then requested to input the time zone of the WSFO. The program creates three files: VERIT, VERDIR, and VERccc, where ccc is the local WSFO AFOS ID.

The VERIT file is a verification information table. It keeps a record of when VERIFY runs and also keeps track of the time of the last surface airways observation (SAO) and surface synoptic report (SSM) read. VERIFY performs its bookkeeping through this file. The format of VERIT is given in Table 2. The VERDIR file is a directory file used to access the VERccc file which contains the collated forecasts and observations. The structure of VERDIR and its data content are given in Table 3.

The file containing the collated forecasts and observations is called VERccc. It is a random RDOS file whose length is dependent on the number of stations being verified. The structure of VERccc is given in Fig. 3. Each block of the file contains data for a maximum of three stations for one forecast cycle. Table 4 gives the data content for a station. The most recent forecasts are stored first in the file. Forecasts get progressively older as you go back in the file.

B. VERIFY

VERIFY reads the VERIT file to determine the cycle time and stations to process. There are three possible ways in which VERIFY can determine the desired cycle. The most frequent way is by adding 12 hours to the last cycle VERIFY processed. However, if VERCREAT has just been run, VERIFY checks the clock time and determines the cycle as follows:

<u>CLOCK TIME (GMT)</u>	<u>DAY</u>	<u>CYCLE</u>
0930 (1030 in PST) <HHMM<2130	Current	0000 GMT
HHMM<0930 (1030 in PST)	Current -1	1200 GMT
HHMM>2130	Current	1200 GMT

NOTE: For Pacific Standard Time (PST), the 0000 GMT cycle cannot be processed until after the 1100 GMT FT has been issued. In all other time zones, and during Daylight Time in the Pacific time zone, the 0000 GMT cycle can be processed any time after 0930 GMT.

The third way VERIFY determines the cycle occurs when the user invokes the override switch. The override switch allows the user to specify a particular cycle. For example, if you wish to run VERIFY on the 1200 GMT cycle of data from the first of March, you would enter at the AFOS console: RUN:VERIFY 30112/0, where "/0" invokes the override switch. This option allows you to reprocess the same cycle to include forecasts which were missing the first time. VERIFY discards all but the last run of duplicate cycles, so forecasts and verifying observations from earlier runs of a cycle are replaced. Note that if the override switch has been used, VERIFY will execute as usual the next time by adding 12 hours to the last cycle processed. So unless the override switch was used to repeat the current forecast cycle, the override switch will probably need to be used the next time to get VERIFY back to the current cycle.

VERIFY then accesses the AFOS database and retrieves the following products:

1. the combined cities forecast bulletin (CCF) for public forecasts,
2. the aviation terminal forecasts (FTA),
3. the manually entered forecasts (MEF),
4. the MOS guidance (FPC),
5. the surface synoptic reports (SSM), and
6. the surface airways observations (SAO).

Local forecasts of max/min temperature and 12-h PoP are taken from the CCF bulletin, along with the public forecaster number. Local forecasts of ceiling height, horizontal visibility, and wind direction and speed extending through the 15-h projection of the aviation forecast are taken from the FTA's. Wind forecasts in the remarks section are correctly obtained. Corrected FTA's are extracted by the software, rather than original "bad" FTA's. Amendments are not used, however. Local forecasts of precipitation type, cloud amount, snow amount, and 42-h significant wind are entered manually in the MEF, as is the aviation forecaster number. The corresponding MOS guidance forecasts are extracted from the FPC product. Verifying observations of snow amount are

obtained from the SSM's; observations of all other elements are obtained from the SAO's. The SSM's are also used as a backup source for retrieving the precipitation amount and daytime max/overnight min temperature observations. Corrected SAO's are extracted by the software, rather than original "bad" SAO's. A correction must be made within 23 hours after the original SAO in order for the software to identify the bad SAO and replace it. Corrections are used even if the corresponding bad SAO's are not found.

VERIFY creates a data file named VOBSxxx for each station, where xxx is a station's AFOS identifier. VERIFY inserts all the decoded SAO's for each xxx into the appropriate VOBSxxx file during its first execution or whenever the VOBSxxx file for a particular station does not already exist. During following runs, VERIFY first checks the create time of the most recent SAO in VOBSxxx, and only decodes SAO's from the AFOS database created subsequent to that time. These new decoded SAO's are then appended to the files. The number of SAO's added to VOBSxxx each run is listed in the MSG product for every station. VERIFY does not attempt to correct out of sequence create times for the SAO's in the AFOS database; it simply discontinues further SAO retrievals for that station. An indication of this problem is when the number of SAO's added to the VOBSxxx file and noted in the MSG product is fewer than should be. A local /S switch and a global /D switch enable the decoding of all SAO's if this problem occurs.

VOBSxxx contains a maximum of 120 decoded SAO's; as new SAO's are added which exceed this limit, the older SAO's are dropped. Retaining decoded SAO's in the VOBSxxx files for future VERIFY runs rather than decoding them again cuts execution times by more than 50%. The VOBSxxx files, however, are not required and VERIFY will run successfully should any of these files inadvertently be deleted. Table 5 gives the data content of the VOBSxxx files.

VERIFY automatically retrieves the correct MEF, CCF, FPC, and FTA from the database to match the selected cycle time. Product times corresponding to each cycle time are found in Table 6. The MEF product time, which is entered manually in the body of the product, is always identical to the cycle time. For the other products, a window about the expected product time is allowed.

VERIFY updates (or builds if just initialized) a public verification matrix product (PVM) and an aviation verification matrix product (AVM), each containing local forecasts and observations. The PVM also contains MOS forecasts, which the AVM does not, since, in general, the MOS guidance will not correspond to the verifying projections from the aviation forecast. Figs. 4 and 5 depict one page of the verification matrix for public and aviation forecasts, respectively. Each is a five-page (10-cycle) product. The first few pages of the product are incomplete with respect to the "observed" column since all events have not yet occurred. In the PVM, each cycle is identified by the day of the month and the GMT cycle time. The projections listed in this product are relative to the cycle time. In the AVM, each cycle is identified by the day of the month and the GMT FT valid time, and the projections are relative to the FT valid time. The user is able to edit either the PVM or the AVM to make corrections. Each time VERIFY executes, the PVM and AVM products are read to obtain previous cycles' forecasts and verifying observations. VERIFY sorts cycles of data in the PVM and AVM into chronological order so that the most recent cycle is always first. It ensures that there are data based on the same



cycles in the PVM and AVM for any particular station. If the date and cycle fields are blank, VERIFY deletes that cycle on the next run. So if a need exists to completely eliminate a cycle, it should be blanked out both in the PVM and AVM. Next, VERIFY updates the PVM and AVM products with the new forecast cycle's data and additional verifying observations which match previous forecasts. VERIFY also updates the VERccc file with the same information. The VERccc file serves as a backup for data in the PVM and AVM. Changes made to the PVM and AVM after VERIFY has run are placed into VERccc the next time VERIFY runs.

If the PVM and AVM products contain 10 cycles, VERIFY prepares the first two stations' data in the oldest cycle (now the 11th) of the VERccc file for transmission to NMC for central archive and inclusion in national summaries. These data are transmitted as a local product with the identifier, cccVERccc, where ccc is the local WSFO ID. The product is stored in the local database and can be displayed by entering VERccc. Fig. 6 shows an example cccVERccc product and Table 7 explains the format of the product.

### Switches

Thirteen switches are available for use with VERIFY. The first seven described below are local switches, while the final six are global switches.

The override switch permits the user to specify a particular cycle for which VERIFY should be run. This option allows the user to reprocess the same cycle to include forecasts which were missing; or, if VERIFY has not been run in several days, this option can be used to skip cycles for which forecasts and observations are no longer in the database. The command to enter at the AFOS console to activate the override switch is RUN:VERIFY MMDDCC/O, where MM is the month number, DD is the day of the month, and CC is the cycle to be processed.

Another local switch is available for stations in which city temperatures are more representative than airport reports for verifying local max/min temperature forecasts. The details of the algorithm for utilizing city reports are contained in Appendix I, Section B. Note that the station must have city reports in the SSM and hourly city temperatures in the SAO as a prerequisite for using the switch. The option is activated by the command RUN:VERIFY xxx/U, where xxx denotes the desired station. A message is written to the MSG product indicating that city temperatures have been initiated at the station. Once the city switch has been activated, observed city temperatures are used for that station in subsequent runs of VERIFY also, regardless of whether the switch is used with the later runs. To terminate city temperatures at a station and return to airport reports, the /A switch should be used. The command is RUN:VERIFY xxx/A. A message is written to the MSG product noting that city temperatures have been eliminated at the station.

A local switch has been included for the purpose of testing at national and regional headquarters. This switch permits the headquarters site to specify the WSFO for which testing is to be conducted; the command to enter is RUN:VERIFY ccc/H, where ccc is the desired WSFO. Note that when VERCREAT is run beforehand, the ccc identifier should be that of the headquarters site. Headquarters sites are able to test more than one WSFO by repeating the execution of VERCREAT and VERIFY for each WSFO. The RDOS files VERIT, VERDIR, and

VERccc where ccc identifies the headquarters site are renamed cccVERIT, cccVERDIR, and VERccc where ccc identifies the WSFO. VERCREAT need only be run once for each WSFO since the files are renamed the first time VERIFY is run. The /H switch prevents transmission of the cccVERccc product.

The /M local switch eliminates flagging of missing values in the PVM and AVM at a selected station. The corresponding messages in the MSG product are likewise withheld for missing values, and a message is written to the MSG product denoting that the switch has been invoked. Note that questionable data continue to be flagged. The /M switch is designed for stations which are routinely missing local forecasts or observations (e.g., part-time stations). The command to enter is RUN:VERIFY xxx/M, where xxx is the desired station. After the switch has been invoked, missing values are not flagged by later runs of VERIFY, regardless of whether the switch is subsequently used. The /N local switch is used to negate the /M switch and resume flagging of missing values for a station. The command is RUN:VERIFY xxx/N. The MSG product contains a message that this switch has been invoked.

The /S local switch decodes all SAO's in the AFOS database for station xxx, rather than only decoding SAO's which are more recent than those in the VOBSxxx file. This switch enables the software to work around non-sequential SAO create times in the AFOS database. The command to enter is RUN:VERIFY xxx/S, where xxx is the appropriate station. The MSG product contains a message that this switch has been invoked.

The /C switch is used to add new observations to the PVM's and AVM's. No new cycle of data is added and no data are transmitted with this option. The command is RUN:VERIFY/C. A message is written to the MSG product noting that VERIFY is being used to collate observations only.

If, for some reason, VERIFY runs, but the oldest cycle of the VERccc file is not successfully transmitted to NMC, you may transmit that particular cycle by using a switch. The command to enter at the AFOS console to accomplish this is RUN:VERIFY/T. This command activates only that software in VERIFY that sends the first two stations in the oldest cycle of the VERccc file to NMC. No matching of forecasts and verifying observations is performed. A message is written to the MSG product noting that VERIFY is being used to transmit data only.

The Revised Digital Guidance (RDG) matrix is no longer required for operation of the AEV software. An option is available, however, which writes MOS and local forecasts into an RDG matrix for each station. The RDG is not used as input by VERIFY, but serves only as an additional format in which to display the forecasts (without the verifying observations). The command for this option is RUN:VERIFY/R. Then enter d:RDGxxx to display the matrix. Be sure to include cccMCPRDG and cccRDGxxx in the AFOS database if this switch is used. A message is written to the MSG product acknowledging the creation of an RDG matrix.

The /X switch should only be used in response to a specific request from TDL. The function of this switch is to transmit three AFOS products (AVM, PVM, and MSG) via AFOS from the WSFO to the WSH AFOS facility, in addition to performing

the usual functions of VERIFY. The switch allows TDL to examine these products during testing periods (e.g., a new AEV software load) and to provide diagnostic assistance. The command is RUN:VERIFY/X. A message in the MSG product notes when these products are being transmitted.

The /B switch is used to signal to VERIFY that the backup VERccc file should be read rather than the PVM and AVM products. This switch is useful for cases in which the PVM and/or AVM are not up-to-date (such as following installation of a backup AFOS database), but the RDOS files are current. The most recent data can be saved by invoking this switch. The command is RUN:VERIFY/B. The MSG product contains a message noting that the current PVM and AVM products are ignored.

The /D switch causes all SAO's in the AFOS database to be decoded for all stations, rather than only decoding SAO's which are more recent than those in the VOBSxxx files. This switch is the global equivalent of the local /S switch. The command to enter is RUN:VERIFY/D. The MSG product contains a message that this switch has been invoked.

### Messages and Error Conditions

VERIFY writes messages which assist the forecaster in diagnosing its completion status. These messages include error conditions which have occurred during the execution of VERIFY, such as locating or decoding an AFOS product. Messages which assist in the quality control of data in the PVM and AVM are also recorded. For a complete description of possible errors, see Appendix II.

Messages are stored in an AFOS product named cccMSGVER. Fig. 7 displays an example cccMSGVER product. This product can be keyed to automatically trigger the alarm/alert upon completion of VERIFY so that by striking the button, the product is displayed on the ADM. To accomplish this, the key for cccMSGVER should be set to alarm/alert for the desired console group. Messages can also be displayed at any time by entering MSGVER at any AFOS console.

### 3. DATA FORMAT

The AFOS displayable products, cccPVMxxx and cccAVMxxx, contain the same information as the RDOS disk file VERccc in a different format. In addition, the VERccc file contains a complete set of MOS forecasts for each cycle for the aviation elements, which are not available in the AVM. For the aviation elements (ceiling, visibility, and wind direction and speed), the MOS forecast projections will not match the local forecast and observations projections. The MOS projections (12-, 15-, 18-, and 24-h) are relative to the cycle time (0000 GMT or 1200 GMT). The verifying projections for the local aviation forecast (0-, 3-, 6-, 9-, and 15-h) and observations are relative to the FT valid time, which varies with time zone and changes from daylight to standard time (or vice versa). For this reason, the MOS data are not included in the AVM product. However, they are available in both the VERccc and the cccVERccc. The PVM and AVM products are provided for easy reference and editing, if necessary. Any changes made to the products will cause the VERccc file to be updated the next time VERIFY executes. Figs. 4 and 5 show one page each of cccPVMxxx and cccAVMxxx products, respectively. These figures also describe the data content of the products.

The VERccc file contains the same 5 days (10 most recent cycles) of data as the database products and an additional eleventh cycle that was transmitted by VERIFY the last time it executed. This eleventh cycle is kept in case a retransmission of the data is necessary. A description of the data in VERccc is found in Appendix I.

#### 4. PROCEDURES

##### A. VERCREAT

The initialization software, VERCREAT, is activated at the Dasher by entering: VERCREAT. The software is run once and executes in 10K words in about 15 seconds. It requires as input the call letters of the local WSFO followed by the call letters of all stations to be verified. A maximum of 12 stations can be verified. The first two stations should be the ones that are participating in the national verification program. The software structure and load line for VERCREAT are given in Fig. 8.

##### B. Manually Entered Forecasts

Some local forecasts cannot be obtained automatically from the forecast products; these forecasts must be manually entered into an AFOS product which is named Manually Entered Forecasts (MEF). Fig. 9 displays a sample MEF product. For each station, there are eight forecasts for four weather elements which need to be inserted: 18-h, 30-h, and 42-h precipitation type; 12-h, 18-h, and 24-h cloud amount; 12 through 24-h snow amount; and 42-h significant wind. Note that these projection times are in relation to model run time (i.e., 0000 or 1200 GMT).

The MEF is a preformatted product which is stored in the local AFOS database as cccMEFccc. The forecaster(s) should fill in the MEF anytime prior to running VERIFY for the desired cycle. The forecaster accesses it by entering m:MEFccc at the AFOS console. After completing the header block, the forecaster enters the forecast cycle (identical to the model run time) and the aviation forecaster number at the top of the MEF. Then he/she inserts the station call letters and corresponding eight forecasts for each station to be verified, up to a maximum of twelve stations. A legend is provided at the bottom of the MEF to assist the user in entering the correctly coded forecasts. Notice that only a "Y" or "N" should be entered for 42-h significant wind; a threshold of 22 kt determines significance.

After all information has been filled in, the forecaster positions the cursor below that information and strikes the enter key to store the product. If further data need to be added later (perhaps by another forecaster) to complete that forecast cycle of the MEF, then he/she should do this by entering e:MEFccc at the AFOS console before running VERIFY. VERIFY then automatically extracts all data from the MEF.

##### C. VERIFY

VERIFY is initiated at the AFOS console by entering: RUN:VERIFY. As explained previously, 13 switches are available for use with VERIFY. The software executes in 32K words in about 5 minutes for three stations; it

requires VERDIR, VERIT, and VERccc (RDOS disk files) which are created by VERCREAT. In addition, Table 8 lists database products required to run VERIFY. The software structure and load line for VERIFY are given in Fig. 10.

#### D. Quality Control

Quality control of the verification data is a necessary step in the AEV system. Fig. 2 depicts how the quality control step fits into the data flow for the AEV software. The forecaster should examine the cccMSGVER product for diagnostics after VERIFY has run. VERIFY writes two types of messages into the product which identify problems in the PVM and AVM: messages which indicate missing or suspect data within one cycle and messages which flag inconsistent data between cycles. Messages caused by missing or suspect data within a cycle indicate the location of problems by specifying the product name, page number, and weather element. The missing or suspect data are also flagged with question marks in the PVM and AVM. Note that blanks are not flagged as missing observations until after the verifying time. Missing MOS values are not flagged at any time because under such circumstances MOS forecasts probably were not available to the forecaster as guidance in preparing his/her forecasts. Thus, missing MOS values need not be added to the PVM. Messages resulting from inconsistent data between cycles indicate the location of problems by specifying the station, cycle times, forecast projections, weather element, and their respective values. Inconsistent data are not flagged with question marks in the PVM and AVM.

If changes or additions are required to the PVM or AVM, they should be made by editing the products via AFOS message compositions. Missing observations which verify more than one cycle need only be added at one place; however, erroneous values must be corrected in each cycle in which they appear. Once VERIFY has obtained an observation in the PVM or AVM, it no longer searches the AFOS database on subsequent runs for corrections or discrepancies. Observations entered into the PVM or AVM are final. All corrections to verification data should be made here.

The PVM and AVM are preformatted AFOS products. To edit them enter e:PVMxxx or e:AVMxxx at the AFOS console. Then, make the required changes in any of the five pages of the products. Due to a deficiency in the AFOS software, hitting the previous page button while editing a preformatted product causes the product to become garbled. Do not hit the previous page button. If you need to go back to a previous page, terminate message composition either by hitting a display clear or by storing the product and then reenter message composition. To store a product, position the cursor in the brackets in the bottom right-hand corner of the last edited page and depress the enter button.

Garbling problems sometimes occur in the PVM or AVM after editing, usually starting with the page following the last edited page. A feature has been incorporated into the AEV software to alleviate these problems as follows. Each page of the PVM and AVM contains brackets in the bottom left-hand corner. Normally, an asterisk appears within those brackets; if garbling occurs and the data become shifted, however, then the asterisk also becomes shifted out of the bottom left-hand corner. As VERIFY reads each page of the PVM and AVM, it checks to see if the asterisk is in the proper position. If the asterisk is correctly placed, then VERIFY uses the data on that page of the PVM or AVM.

But if not, VERIFY uses the VERccc file (created the previous time VERIFY was run) as a backup to replace that page and all subsequent pages in the product. Thus, any garbling which results from editing a PVM or AVM during the quality control step is immediately eliminated during the next cycle of VERIFY. The beginning page of the replacement is specified in the MSG product. The only drawback is that quality control must be repeated after VERIFY has run if any pages which have been replaced had been edited.

#### 5. CAUTIONS

VERIFY decodes up to 120 surface airways observations (SAO's) and up to 12 surface synoptic reports (SSM's). An effort has been made to correct systematic errors that may occur in the decoding of observations. However, the decoders are not fail proof, and occasionally an SAO or SSM will contain errors and cause the decoding of that report to cease. When this happens, the observation that had the error is written to the MSG product. It is important that the forecaster supply the PVM and/or AVM product(s) with the missing information from that report.

#### 6. REFERENCES

Barker, T. W., 1987: AEV local verification for aviation, precipitation and temperature programs: AV, REL, TEM. Western Region Computer Programs and Problems, NWS WRCP - No. 42, National Oceanic and Atmospheric Administration, U. S. Department of Commerce. (In press).

National Weather Service, 1973: Combined aviation/public weather forecast verification. National Weather Service Operations Manual, Chapter C-73, National Oceanic and Atmospheric Administration, U.S. Department of Commerce, 14 pp.

\_\_\_\_\_, 1982a: National Verification Plan. National Oceanic and Atmospheric Administration, U.S. Department of Commerce, 81 pp.

\_\_\_\_\_, 1982b: Public forecast verification. National Weather Service Operations Manual, Chapter C-71, National Oceanic and Atmospheric Administration, U.S. Department of Commerce, 8 pp.

7. PROGRAM INFORMATION AND PROCEDURES FOR INSTALLATION AND EXECUTION

I. INITIALIZATION PROGRAM FOR LOCAL  
AFOS-ERA FORECAST VERIFICATION SOFTWARE

PART A: PROGRAM INFORMATION and INSTALLATION PROCEDURE

PROGRAM NAME: VERCREAT AAL ID: MSC006  
Revision No.: 01.00

FUNCTION: Creates the verification information table (VERIT) file, the verification directory (VERDIR) file, and the file containing collated forecasts and observations (VERccc) for a particular WSFO. Accepts WSFO call letters, stations to verify, and the time zone of the WSFO from the Dasher.

PROGRAM INFORMATION:

Development Programmer(s): Mary M. Heffernan	Maintenance Programmer(s): AFOS Applications Librarian
Location: Techniques Development Laboratory Phone: (FTS) 427-8065	Location: Techniques Development Laboratory Phone: (FTS) 427-8065
Language: FORTRAN IV/Revision 5.20	Type: Standard program
Save file creation dates: Original release/Revision 01.00	- August 29, 1983
Running time: 15 seconds	
Disk Space: Program files Data files	- 22 RDOS blocks - 11 RDOS blocks

PROGRAM REQUIREMENTS

Program files:

NAME

VERCREAT.SV

Data files:

<u>NAME</u>	<u>Disk location</u>	<u>READ/WRITE</u>	<u>COMMENTS</u>
VERIT	Master directory	W	Created by program
VERDIR	Master directory	W	Created by program
VERccc	Master directory	W	Created by program

AFOS Products: None

LOAD LINE

RLDR VERCREAT UTIL.LB FORT.LB

PROGRAM INSTALLATION

1. Move VERCREAT.SV to the master directory or an applications directory with links to the master directory.
2. Be prepared to give your WSFO's identifier (ccc), stations to be verified (xxx), and the time zone of your WSFO.



PART B: PROGRAM EXECUTION and ERROR CONDITIONS

PROGRAM NAME: VERCREAT

AAL ID: MSC006

Revision No.: 01.00

PROGRAM EXECUTION

NOTE: VERCREAT should be run only once: during initialization for the local software. VERCREAT.SV may be deleted after successful execution.

1. From the Dasher enter:

VERCREAT

2. Enter answers to questions asked.

A listing of the stations to be verified followed by the "R" prompt denotes successful execution of the program.

ERROR CONDITIONS

Error conditions occur only while manipulating files. These include opening channels to; setting position of; and reading, closing, creating, and writing to files. Error messages in all cases explain which file is being handled at the time of the problem.

II. COLLATION PROGRAM FOR LOCAL  
AFOS-ERA FORECAST VERIFICATION SOFTWARE

PART A: PROGRAM INFORMATION and INSTALLATION PROCEDURE

PROGRAM NAME: VERIFY

AAL ID: MSC006

Revision No.: 04.20

FUNCTION: Extracts local and MOS forecasts of public elements and local forecasts of aviation elements for each station being verified. Obtains the verifying observations to match the forecasts. Collates the forecasts and observations of the past 10 cycles (5 days). Builds two AFOS products (Public Verification Matrix and Aviation Verification Matrix) and an RDOS disk file (VERccc) containing these data. Transmits the eleventh (oldest) cycle of collated data for the first two stations to NMC.

PROGRAM INFORMATION:

Development Programmer(s):

Christine L. Alex  
David P. Ruth  
Robert L. Miller  
Mary M. Heffernan

Maintenance Programmer(s):

Christine L. Alex

Location: Techniques Development  
Laboratory

Phone: (FTS) 427-7639

Language: FORTRAN IV/Revision 5.20

Location: Techniques Development  
Laboratory

Phone: (FTS) 427-7639

Type: Overlay program

Save file creation dates:

Original release/Revision 01.00	-	May 9, 1984
First revision/Revision 02.00	-	July 24, 1984
Second revision/Revision 02.10	-	September 4, 1984
Third revision/Revision 02.11	-	September 24, 1984
Fourth revision/Revision 03.00	-	October 1, 1985
Fifth revision/Revision 03.10	-	November 17, 1986
Sixth revision/Revision 04.20	-	May 28, 1987
(Rev 04.21 in Western Region)		

Running time: 5 minutes for  
3 stations

Disk Space: Program files  
Data files

- 411 RDOS blocks  
- 30 RDOS blocks per 3 stations

PROGRAM REQUIREMENTS

Program files:

NAME

VERIFY.SV  
VERIFY.OL

Data files:

<u>NAME</u>	<u>Disk location</u>	<u>READ/WRITE</u>	<u>COMMENTS</u>
VERIT	Master directory	R/W	Created by VERCREAT
VERDIR	Master directory	R/W	Created by VERCREAT
VERccc	Master directory	R/W	Created by VERCREAT
VOBSxxx	Master directory	R/W	Created by VERIFY

AFOS Products:

<u>ID</u>	<u>ACTION</u>	<u>COMMENTS</u>
cccMEFccc	Accessed	Use m:MEFccc to enter forecasts prior to running VERIFY.
cccPVMxxx	Stored	Use d:PVMxxx to display.
cccAVMxxx	Stored	Use d:AVMxxx to display.
cccVERccc	Stored	Data from oldest cycle transmitted to NMC in this product.
cccMSGVER	Stored	Contains messages denoting the completion status of VERIFY, including error conditions.

LOAD LINE

```

RLDR VERIFY VEREV
[VSTART FILLVM NAFREAD IUANDEC, FTA CLD VSBLTY WTHR CHEKR LZOUT,
ROB FILTER STRING COBP COMTIM, UPVERCCC WVRDR TRMIT WIVT QMARK CPTYP]
[RCOMLN RIVT OPNVER RVRDR MGLOB GTCYC DTCYC MEF CCF DCCF,
SPCASE DCDFT GETRMK FPC MERGE,
REMDEC CLDCHK GETCLD RSATIM SORT BAKUP GETHT GETYPE LOHT,
INITVM PVM PTYPE AVM RDVERCC CONSIS IKRT CHEKP CHEKA MCNSIS,
SORTAP SORTIS INITIS TRANS DUPE CMPRE PRINT SSM IUNTN DSSM
OSOB RSOB WSOB CORSAO,
AIRDX INTGR CLOUD PRECIP SKY VSBYWX BLKCHK WIND TEMPDP DRSP REMARK
DECVIS WX MAXMIN INTALL IFAH ICEL BFILL POBS,
MATCH MMTEMP MMSAO POP12 PRECTYP SNOWAMT CLDAMT CIGVIS
WINDS PROJ SPECOB SPECSSM MAXSPD ADDHR,
WRDG WPVM WAVM FLLTB CONVERT]
GETCST GETOBS UPDATV SUBHR AFDTIM DCMPR SSEARCH COUNT CKEY CHKBAD MADM
STNDTM ROUND
UTIL.LB BG.LB FORT.LB

```

NOTE: THE FOLLOWING ROUTINES REQUIRE FPAFOS.FR DURING COMPILATION: CCF, FTA, SSM, WRDG, WAVM, WPVM.

PROGRAM INSTALLATION

1. Move VERIFY.SV and VERIFY.OL to the master directory or an applications directory with links to the master directory.
2. Store preformats cccMCPAVM, cccMCPVPM, and cccMCPMEF into the database.

PART B: PROGRAM EXECUTION and ERROR CONDITIONS

PROGRAM NAME: VERIFY

AAL ID: MSC006

Revision No.: 04.20

PROGRAM EXECUTION

1. From the AFOS console enter:

RUN:VERIFY/C/R/T/X/B/D MMDDCC/O ccc/H xxx/U xxx/A xxx/M xxx/N xxx/S

Definition of switches:

- /C = Adds new observations to the PVM's and AVM's without running a new cycle.
- /R = Writes MOS and local forecasts into the RDG product which serves as an additional format to display them.
- /T = Transmits the oldest cycle of the VERccc file to NMC without executing any other portions of VERIFY.
- /X = Transmits AVM, PVM, and MSG products to the WSH AFOS facility for TDL to monitor.
- /B = Reads backup VERccc file rather than the PVM and AVM products.
- /D = Decodes all SAO's in the AFOS database for all verification stations rather than decoding SAO's which are more recent than those in the VOBSxxx files.
- MMDDCC/O = Specifies the cycle which should be run; MM is the month number, DD is the day of the month, and CC is the cycle.
- ccc/H = Used for testing at national and regional headquarters; ccc is the WSFO that the headquarters site wants to test.
- xxx/U = Uses city temperatures rather than airport reports for verifying local max/min temperature forecasts at station xxx.
- xxx/A = Eliminates city temperatures and returns to airport reports at station xxx.
- xxx/M = Eliminates flagging of missing values in the PVM and AVM at a selected station (xxx). Once M is invoked, it remains "on" for following VERIFY runs until revoked by the N switch.
- xxx/N = Restores flagging of missing values--switches off the action of the M switch for station xxx.
- xxx/S = Decodes all SAO's in the AFOS database for station xxx, rather than only decoding SAO's which are more recent than those in the VOBSxxx file.

Defaults [Switch not present on RUN: command line]:

- /C = Runs VERIFY with a new cycle.
- /R = RDG product is not used.
- /T = Runs all of VERIFY.
- /X = Products are not transmitted to TDL.

/B = Reads PVM and AVM products.  
/D = Decodes verification SAO's that are more recent than those in the VOBSxxx files.  
/O = Runs cycle which is 12 hours after the previously run cycle.  
/H = Not a headquarters site.  
/U = City temperatures are not used.  
/A = City temperatures are not eliminated.  
/M = Flags missing values.  
/N = No negation of /M switch.  
/S = Decodes only recent SAO's.

2. The alarm/alert is triggered upon completion of the program; striking the alarm/alert results in the cccMSGVER product being displayed on the ADM.

#### ERROR CONDITIONS

For a complete description of possible errors, see Appendix II.

The most common error messages are related to decoding SAO's or SSM's. User action may be required to manually input an observation not in the PVM or AVM when the data cannot be decoded.

Table 1. Forecast elements to be verified. Projections given for public elements are in relation to model run time (0000 or 1200 GMT). Projections given for aviation elements are relative to the beginning of a scheduled FT valid period (e.g., 0900 or 1800 GMT when standard time is in effect in the Eastern Time Zone). Elements with asterisks must be manually entered into the MEF AFOS product.

Forecast Element	Projection (h)
<u>PUBLIC ELEMENTS</u>	
Maximum Temperature	12 - 24 and 36 - 48 (0000 GMT) 24 - 36 and 48 - 60 (1200 GMT)
Minimum Temperature	24 - 36 and 48 - 60 (0000 GMT) 12 - 24 and 36 - 48 (1200 GMT)
Probability of Precipitation	12 - 24, 24 - 36, and 36 - 48
Precipitation Type	18*, 30*, and 42*
Cloud Amount	12*, 18*, and 24*
Snow Amount	12 - 24*
Significant Wind ( $\geq$ 22 kt) [Y/N]	42*
<u>AVIATION ELEMENTS</u>	
Ceiling Height	3, 6, 9, and 15
Visibility	3, 6, 9, and 15
Wind Speed and Direction	3, 9, and 15

Table 2. Format of the VERIT file. Data type "A" indicates ASCII data; data type "B" indicates binary data.

Word Number	Information	Data Type
1-2	WSFO call letters	A
3	Number of stations to verify	B
4	Number of bytes of data per station	B
5-6	1st station call letters	A
7	Time zone of WSFO	B
8	Month * 100 + Day of last cycle VERIFY processed	B
9	Cycle time (0000 or 1200) of last cycle VERIFY processed	B
10	City temperature used for verifying observation? (YES = 1)	B
11	Flag missing values in PVM and AVM? (YES = 1)	B
12	Month * 100 + Day of last SAO read	B
13	Hour * 100 + Minute of last SAO read	B
14	Month * 100 + Day of last SSM read	B
15	Hour * 100 + Minute of last SSM read	B

Words 5 through 15 are repeated for up to twelve stations.



Table 3. Format of the VERDIR file. Current values of variables are shown in parentheses where appropriate. Data type "A" indicates ASCII data; data type "B" indicates binary data.

Word Number	Information	Data Type
1-2	WSFO call letters	A
3	Number of stations being verified (maximum is 12)	B
4	Spare	
5-6	1st station's call letters	A
7-8	2nd station's call letters	A
9-10	3rd station's call letters	A
11-12	4th station's call letters	A
13-14	5th station's call letters	A
15-16	6th station's call letters	A
17-18	7th station's call letters	A
19-20	8th station's call letters	A
21-22	9th station's call letters	A
23-24	10th station's call letters	A
25-26	11th station's call letters	A
27-28	12th station's call letters	A
29	Number of cycles in file for station 1	B
30	Number of cycles in file for station 2	B
31	Number of cycles in file for station 3	B
32	Number of cycles in file for station 4	B
33	Number of cycles in file for station 5	B
34	Number of cycles in file for station 6	B
35	Number of cycles in file for station 7	B
36	Number of cycles in file for station 8	B
37	Number of cycles in file for station 9	B
38	Number of cycles in file for station 10	B
39	Number of cycles in file for station 11	B
40	Number of cycles in file for station 12	B
41	Number of words of data reserved for each station (85)	B
42	Number of stations per block (3)	B
43	Spare	
44	Length of header information for each station (6)	B
45	Code for M/M temp (100)	B
46	Offset for M/M temp data/length of data (0016)	B
47	Code for 12-h PoP (200)	B
48	Offset for 12-h PoP data/length of data (1612)	B
49	Code for precip type (300)	B
50	Offset for precip type data/length of data (2812)	B
51	Code for 12-h snow amount (400)	B
52	Offset for 12-h snow amount data/length of data (4004)	B
53	Code for cloud amount (500)	B
54	Offset for cloud amount data/length of data (4412)	B
55	Code for ceiling height (600)	B
56	Offset for ceiling height data/length of data (5618)	B
57	Code for visibility (700)	B
58	Offset for visibility data/length of data (7418)	B
59	Code for wind (800)	B
60	Offset for wind data/length of data (9232)	B
61-68	Spare	

Table 4. Data content for one station for one forecast cycle in the VERccc file. Projection times for public elements and for all MOS forecasts are relative to model run (cycle) time. Projection times for aviation elements are relative to the beginning of a scheduled FT valid period (continued on next page).

Word Number	Information	
1-2	Station call letters	
3	Year/month	
4	Day/cycle	
5	Public forecaster #/aviation forecaster #	
6	Offset (HHMM) between cycle time and FT time	
7	MOS temp/local temp	12-24 h
8	Spare/observed daytime max or overnight min temp	
9	MOS temp/local temp	24-36 h
10	Spare/observed daytime max or overnight min temp	
11	MOS temp/local temp	36-48 h
12	Spare/observed daytime max or overnight min temp	
13	MOS temp/local temp	48-60 h
14	Spare/observed daytime max or overnight min temp	
15	MOS PoP/local PoP	12-24 h
16	Observed amount	
17	MOS PoP/local PoP	24-36 h
18	Observed amount	
19	MOS PoP/local PoP	36-48 h
20	Observed amount	
21	MOS precip type/local precip type	18 h
22	Verifying hour/2-h window	
23	MOS precip type/local precip type	30 h
24	Verifying hour/2-h window	
25	MOS precip type/local precip type	42 h
26	Verifying hour/2-h window	
27	MOS snow amount/local snow amount	12-24 h
28	Observed snow amount	
29	MOS cloud amount/local cloud amount	12 h
30	Observed cloud amount	
31	MOS cloud amount/local cloud amount	18 h
32	Observed cloud amount	
33	MOS cloud amount/local cloud amount	24 h
34	Observed cloud amount	
35	12-h MOS ceiling height/3-h local ceiling height	
36	0-h ceiling persistence	
37	3-h observed ceiling height	
38	15-h MOS ceiling height*/6-h local ceiling height	
39	6-h observed ceiling height	
40	18-h MOS ceiling height/9-h local ceiling height	
41	9-h observed ceiling height	
42	24-h MOS ceiling height/15-h local ceiling height	
43	15-h observed ceiling height	
44	12-h MOS visibility/3-h local visibility	
45	0-h visibility persistence	
46	0-h observed visibility	

Table 4. (continued).

Word Number	Information	
47	15-h MOS visibility*/6-h local visibility	
48	6-h observed visibility	
49	18-h MOS visibility/9-h local visibility	
50	9-h observed visibility	
51	24-h MOS visibility/15-h local visibility	
52	15-h observed visibility	
53	12-h MOS wind	
54	Local forecast wind	3-h
55	Observed wind at hour	
56	Peak sustained wind in 6-h window	
57	18-h MOS wind	
58	Local forecast wind	9-h
59	Observed wind at hour	
60	Peak sustained wind in 6-h window	
61	24-h MOS wind	
62	Local wind	15-h
63	Observed wind at hour	
64	Peak sustained wind in 6-h window	
65	42-h MOS wind	
66	Local wind forecast (significant or not)	42-h
67	Observed wind at hour	
68	Peak sustained wind in 6-h window	
69-85	Spare words	

\*Forecast is not currently available.

Table 5. Format of the VOBSxxx file. All data are binary.

Word Number	Information
1	Month * 100 + day the most recent SAO was created
2	Hour * 100 + minute the most recent SAO was created
3	Number of decoded SAO's stored in this file
4	Month * 100 + day of SAO observation time
5	Hour * 100 + minute of SAO observation time
6	SAO type/max or min temperature
7	Precip amount
8	Precip type
9	Cloud amount/ceiling height
10	Wind direction and speed
11	Visibility
12	Hourly temperature/city hourly temperature

Words 4 through 12 are repeated for up to 120 observations. The most recent observations appear first.

Table 6. Product time (GMT) required for each cycle processed by VERIFY.  
 Enclosed in parentheses is the allowed time range of products used in the program.

Product	Time Zone	Product Time	
		0000 GMT Cycle	1200 GMT Cycle
MEF	All	0000	1200
CCF	All	1000 (0200-1100)	2200 (1400-2300)
FPC	All	0400 (0100-0700)	1600 (1300-1900)
FTA			
	EST	0900 (0800-1000)	1800 (1700-1900)
	EDT	0800 (0700-0900)	1700 (1600-1800)
	CST	0900 (0800-1000)	1800 (1700-1900)
	CDT	0800 (0700-0900)	1700 (1600-1800)
	MST	1000 (0900-1100)	1900 (1800-2000)
	MDT	0900 (0800-1000)	1800 (1700-1900)
	PST	1100 (1000-1200)	2000 (1900-2100)
	PDT	1000 (0900-1100)	1900 (1800-2000)

Table 7. Format of the cccVERccc message. Data from two stations are transmitted in each bulletin. Projections for public elements and for all MOS forecasts are relative to model run (cycle) time. Projections for aviation elements are relative to the beginning of a scheduled FT valid period (continued on next page).

Line	Contents
100	Temperature: 16 pieces of information (°F) 1 - MOS forecast (calendar day max or min) 2 - Local 12-24 h forecast (daytime max or overnight min) 3 - Not used 4 - Daytime max/overnight min observation 5 - MOS forecast 6 - Local 24-36 h forecast 7 - Not used 8 - Daytime max/overnight min observation <p style="text-align: right;">Pattern repeats for 48- and 60-h fcsts</p>
200	Probability of Precipitation: 9 pieces of information 1 - MOS 12-24 h PoP 2 - Local 12-24 h PoP 3 - Observed precip amount (hundredths of inches, trace = -2) <p style="text-align: right;">Pattern repeats for 36- and 48-h fcsts</p>
300	Precipitation Type: 12 pieces of information 1 - MOS 18-h PoPT forecast (category 1, 2, 3) 2 - Local 18-h PoPT forecast (category 1, 2, 3) 3 - Observation in form XYZ where X = 0 (1) if no freezing (freezing occurred); Y = 0 (2) if no snow (snow occurred); and Z = 0 (3) if no liquid precip (liquid precip occurred). 4 - Same (XYZ) as 3 above except the obser- vation is for a 2-h window. <p style="text-align: right;">Pattern repeats for 30- and 42-h fcsts</p>
400	Snow Amount: 3 pieces of information 1 - MOS 12-24 h snow amount forecast (category 0, 2, 4, 6) 2 - Local 12-24 h snow amount forecast (inches) 3 - Observed snow amount (inches)
500	Cloud Amount: 9 pieces of information 1 - MOS 12-h forecast (category 1, 2, 3, 4) 2 - Local 12-h forecast (category 1, 2, 3, 4) 3 - Observed cloud amount (category 1, 2, 3, 4) <p style="text-align: right;">Pattern repeats for 18- and 24-h fcsts</p>

Table 7. (continued on next page).

Line	Contents
600	Ceiling Height: 13 pieces of information 1 - 0-h persistence observation (hundreds of feet) 2 - MOS 12-h forecast (category 1, 2, 3, 4, 5, 6) 3 - Local 3-h forecast (hundreds of feet) 4 - 3-h observed ceiling height (hundreds of feet) 5 - MOS 15-h forecast (category 1, 2, 3, 4, 5, 6)* 6 - Local 6-h forecast (hundreds of feet) 7 - 6-h observed ceiling height (hundreds of feet) 8 - MOS 18-h forecast (category 1, 2, 3, 4, 5, 6) 9 - Local 9-h forecast (hundreds of feet) 10 - 9-h observed ceiling height (hundreds of feet) 11 - MOS 24-h forecast (category 1, 2, 3, 4, 5, 6) 12 - Local 15-h forecast (hundreds of feet) 13 - 15-h observed ceiling height (hundreds of feet)
	96 = ceiling above 9000 feet 97 = unlimited ceiling
700	Visibility: 13 pieces of information 1 - 0-h persistence observation (hundredths of miles) 2 - MOS 12-h forecast (category 1, 2, 3, 4, 5, 6) 3 - Local 3-h forecast (miles and quarters of miles) 4 - 3-h observed visibility (hundredths of miles) 5 - MOS 15-h forecast (category 1, 2, 3, 4, 5, 6)* 6 - Local 6-h forecast (miles and quarters of miles) 7 - 6-h observed visibility (hundredths of miles) 8 - MOS 18-h forecast (category 1, 2, 3, 4, 5, 6) 9 - Local 9-h forecast (miles and quarters of miles) 10 - 9-h observed visibility (hundreds of miles) 11 - MOS 24-h forecast (category 1, 2, 3, 4, 5, 6) 12 - Local 15-h forecast (miles and quarters of miles) 13 - 15-h observed visibility (hundreds of miles)
	80 = local forecasts of visibilities greater than 7 miles 800 = observed visibility greater than 7 miles

Table 7. (continued).

Line	Contents	
800	Wind: 16 pieces of information	
	1 - MOS 12-h wind forecast (ddff)	
	2 - Local wind forecast (ddff)	3-h
	3 - Observed wind direction and speed (ddff)	
	4 - Observed peak sustained wind direction and speed in 6-h window (ddff)	
	5 - MOS 18-h wind forecast (ddff)	
	6 - Local wind forecast (ddff)	9-h
	7 - Observed wind direction and speed (ddff)	
	8 - Observed peak sustained wind direction and speed in 6-h window (ddff)	
	9 - MOS 24-h wind forecast (ddff)	
	10 - Local wind forecast (ddff)	15-h
	11 - Observed wind direction and speed (ddff)	
	12 - Observed peak sustained wind direction and speed in 6-h window (ddff)	
	13 - MOS 42-h wind forecast (ddff)	
	14 - Local wind forecast (ddff)	42-h
	15 - Observed wind direction and speed (ddff)	
	16 - Observed peak sustained wind direction and speed in 6-h window (ddff)	

Note: For local 42-h wind forecast, Y is coded as 2322 and N is coded as 2302.

\*Forecast is not currently available.

Table 8. AFOS database products required by the AEV software.

AFOS ID	Product Description	Fields Only	Purge Parameter
cccMCPVPM	Preformat for public verification matrix	0=1	001M
cccMCPAVM	Preformat for aviation verification matrix	0=1	001M
cccMCPMEF	Preformat for manually entered forecasts	0=1	001M
cccFPCxxx	MOS matrix for verification station		005M*
cccPVMxxx	Collated MOS, local public forecasts, and observations for station xxx for five days		002M
cccAVMxxx	Collated local public forecasts and observations for station xxx for five days		002M
cccCCFccc	Combined cities forecast bulletin-FP4		005M*
cccFTAxxx	Aviation terminal forecasts		010M*
cccSAOxxx	Surface airways observations		072M
cccSSMxxx	Synoptic observations		012M
cccVERccc	Station verification data to be transmitted to NMC		001M
cccMEFccc	Manually entered forecasts		005M*
cccMSGVER	Messages and error conditions which are output by AEV software		005M*
cccMCPRDG	Preformat for MOS and local forecast matrix (this product is optional)	0=1	001M
cccRDGxxx	MOS and local forecasts for station (this product is optional)		002M

\*The number of versions of these products stored can be reduced. These numbers provide flexibility in being able to run the AEV software for up to 2 days late.



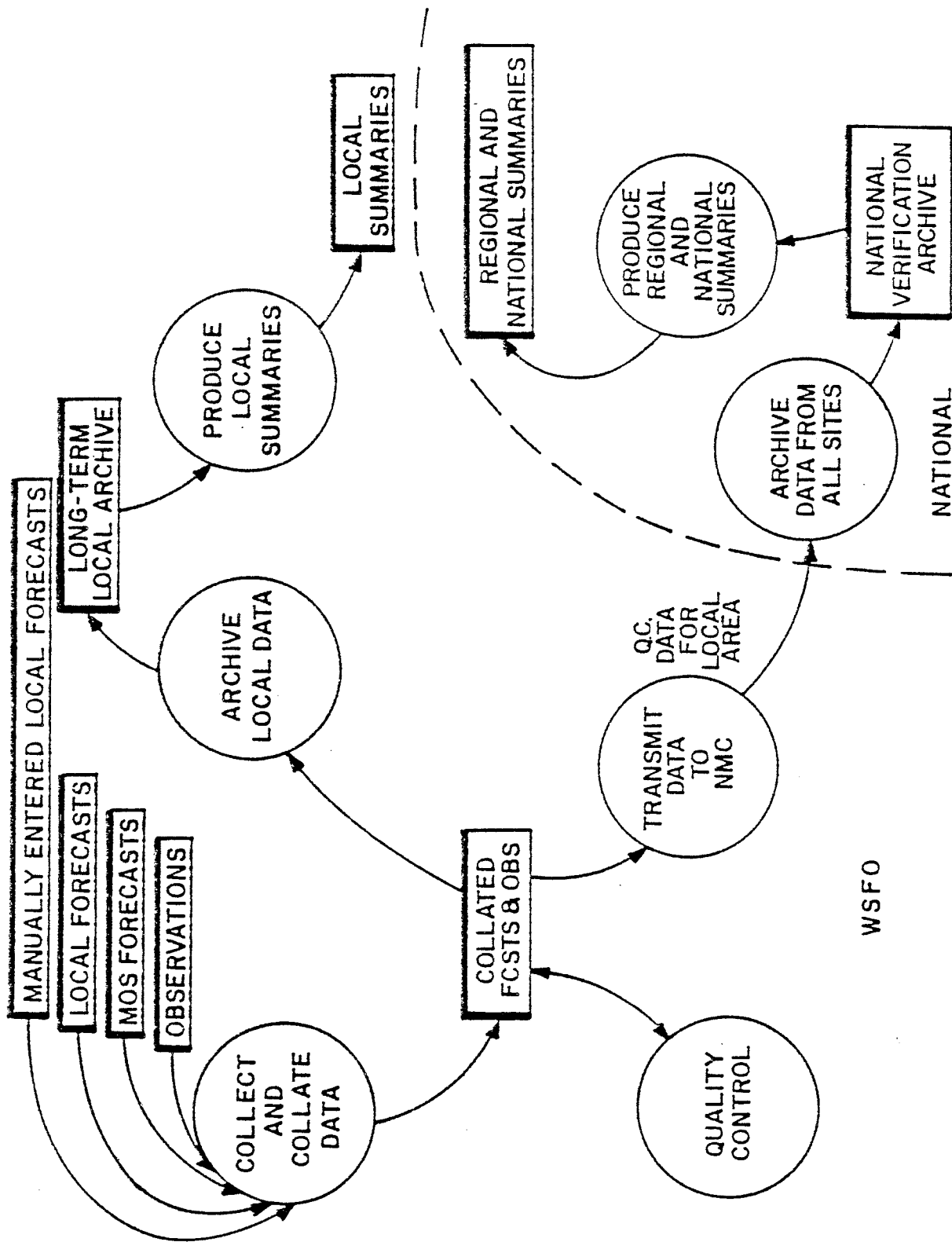

Figure 1. Overview of the AFOS-era verification system. Software described here is implemented at the WSFO and performs the functions of collecting and collating forecasts and observations and transmission of data to NMC.

WSFO

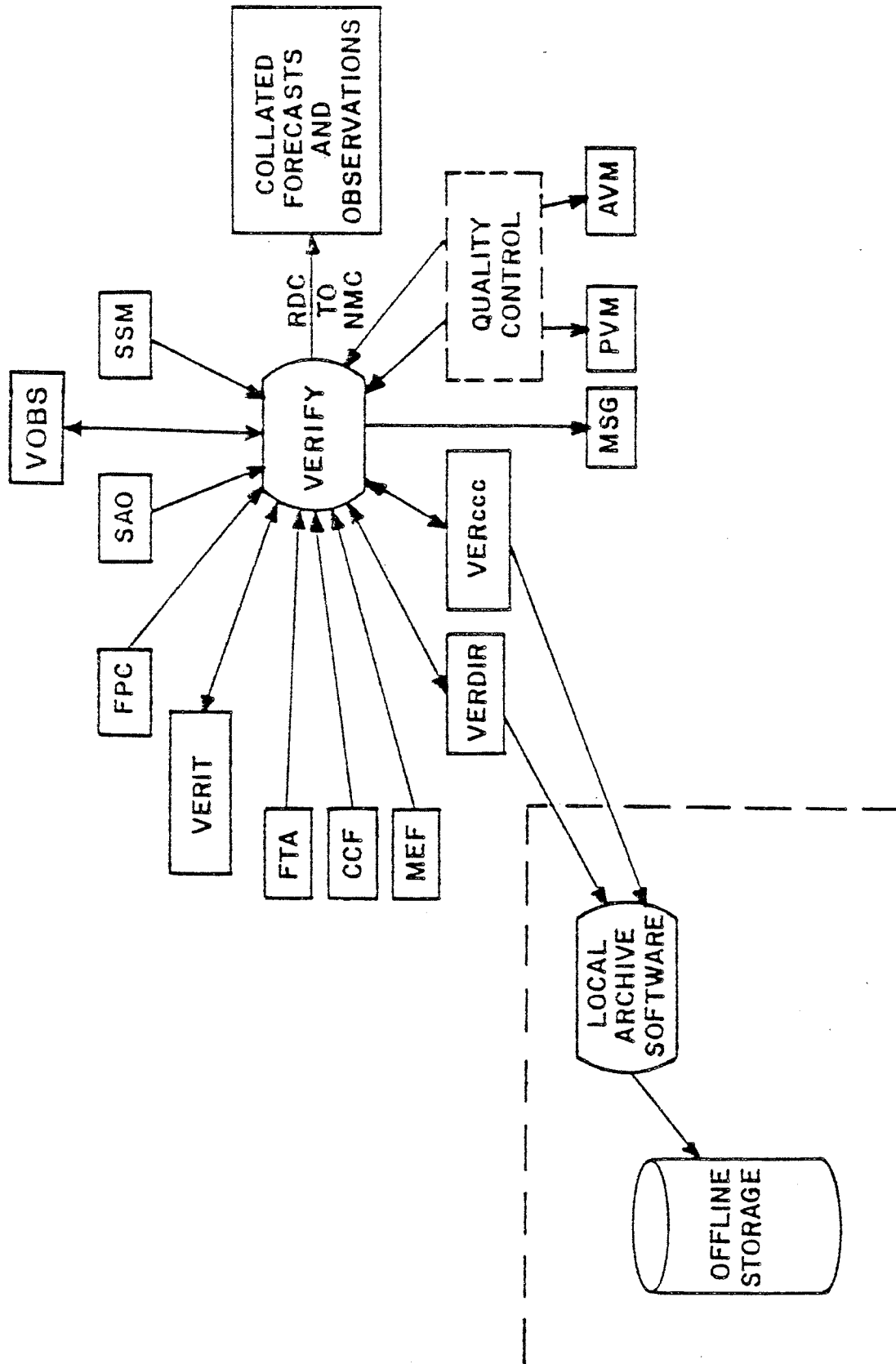

Figure 2. Data flow for the local AEV software.

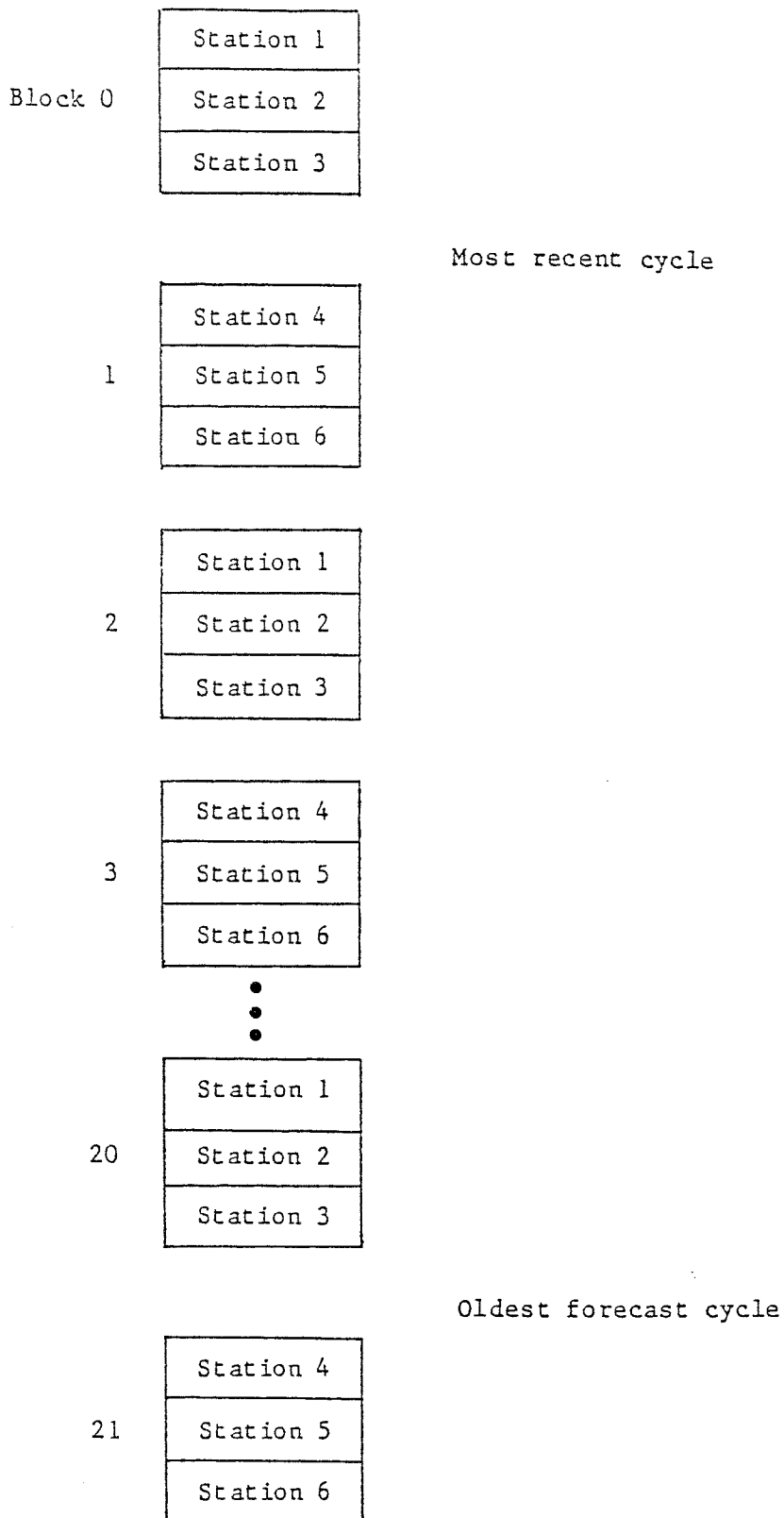

Figure 3. Format of VERccc file for most recent 11 forecast cycles of a WSFO archiving for 6 stations. For 3 or less stations the length would be 11 blocks; for 4 to 6 stations the length would be 22 blocks; and so on until for 10 to 12 stations the length would be 44 blocks.

LEX		1029	1200	FORECASTER 17		1029	0000	FORECASTER 15	
ELEMENT	PROJ	MOS	LOCAL	OBSERVED		MOS	LOCAL	OBSERVED	
TEMP M/M	12-24	47	54	45		68	62	54	
DEG F	24-36	64	64	60		52	49	45	
24H/12H	36-48	52	56	52		63	59	60	
	48-60	64	64	71		52	49	52	
12H POP	12-24	40	00	11		30	20	37	
PERCENT	24-36	70	00	2		70	70	11	
	36-48	70	00	1		00	00	2	
POPT	18(+1)	3	3	003	003	3	3	003	003
CTGY	30(+1)	3	3	000	000	3	3	003	003
Z/F/L	42(+1)	3	3	000	000	3	3	000	000
SNOW AMT	12-24	0	0	0		0	0	0	
CTGY/INCHES									
WINDS	42(+3)	0711	N	9610?	9610?	1212	N	0309	0612
SIG/DEG-KTS									
CLOUD AMT	12	4	4	4		3	4	4	
CTGY	18	4	4	4		3	4	4	
	24	4	4	4		4	4	4	

\*

[ ]  
PAGE 05

One page of a Public Verification Matrix (PVM) product for one station. The forecasts get progressively older as you page through this five-page product. The time referenced for each cycle in the PVM is the model run (cycle) time. All projections in the PVM are relative to the cycle time. A brief description of the data elements follows. For more details refer to Appendix I.

TEMP M/M--MOS and local forecasts are daytime max/overnight min temperatures. The observed temperature is the daytime max/overnight min derived by a comprehensive algorithm. All values are in degrees Fahrenheit.

PoP--MOS and local 12-h PoP forecasts are given in percent. The observed value is in hundredths of inches; a trace is coded as a minus 2. The observed amount is the sum of two 6-h amounts from the SAO's, or, if unavailable, the SSM's. If either 6-h period is missing from both the SAO and the SSM, the 12-h precipitation amount is reported as missing.

PoPT--Forecasts and observed values of precipitation type are categorical with a value of 1, 2, or 3 for freezing, frozen, and liquid precipitation, respectively. Three digits are reserved for each observed field which allows for a mixture of precipitation type to be recorded. The first observed field is from the routine surface observation at the verifying hour. The second observed field is a composite of precipitation for a 2-h window about the verifying hour.

SNOW AMT--MOS forecasts are categorical. The categories are 0)  $\leq 1$ , 2) 2-3, 4) 4-5, 6)  $\geq 6$  inches. Local forecasts and observed values are in whole inches. The observed snow amount is the sum of two 6-h amounts from the SSM's. If either 6-h period is missing, the 12-h snow amount is reported as missing.

Figure 4. Public Verification Matrix product (continued on next page).

WINDS--MOS wind forecasts and observed directions and speeds are given in tens of degrees/knots. Local wind forecasts are either a "Y" or "N" for significant wind according to a threshold of 22 kt. The first observed wind is from the routine surface observation at the verifying hour. The second observed wind is the highest sustained wind reported in a 6-h window about the verifying hour.

CLD AMT--Cloud amount forecasts and observations are categorical with values of 1 through 4. The categories are 1) CLR, -X, -SCT, -BKN, -OVC, 2) SCT, 3) BKN, 4) X, OVC.

---

Figure 4. (continued).

LEX		0603	FT 1700	FCSTR 07		0603	FT 0800	FCSTR 16
ELEMENT	PROJ	LOCAL		OBSERVED		LOCAL		OBSERVED
CEILING	0			25				55
CTGY/FEET	3	15		97		97		48
	6	15		97		80		70
	9	80		70		80		25
	15	96		41		80		97
VISIBILITY	0			700				800
CTGY/MILES	3	80		700		80		600
	6	80		700		80		700
	9	80		700		80		700
	15	80		700		80		700
WINDS	3(+3)	2907	2909	2909		0000	2003	3208
DEG-KTS	9(+3)	3108	2904	3305		2807	?	2909
	15(+3)	3607	3305	3305		2807	3305	2909

\*

[ ]

One page of an Aviation Verification Matrix (AVM) product for one station. The forecasts get progressively older as you page through this five-page product. The time referenced for each cycle in the AVM is the beginning of a scheduled FT valid period; all projections in the AVM are relative to this time. Note that the AVM does not contain MOS forecasts, since, in general, the MOS guidance will not correspond to the verifying projections from the FT. A brief description of the data elements follows. For more details, refer to Appendix I.

CIG--Local forecasts and observed heights are given in hundreds of feet with 96 for a ceiling above 9000 ft and 97 for an unlimited ceiling.

VIS--Local forecasts are two digits where the first is miles and the second is quarters of miles; visibilities over 7 miles are coded as 80. Observed visibilities are given in hundredths of miles; visibilities over 7 miles are coded as 800.

WINDS--Local wind forecasts and observed directions and speeds are given in tens of degrees/knots. The first observed wind is from the routine surface observation at the verifying hour. The second observed wind is the highest sustained wind reported in a 6-h window about the verifying hour.

---

Figure 5. Aviation Verification Matrix product.

```
SLCVERSLC
FPUSS5 KWBC SLC 2
SLC 87070100
100 92 94      93 65 63      62 91 91      93 63 62      62
200 20 10     0 10 10     0 5 10 0
300 3000000 3000000 3000000
400 0 0
500 233 221 331
600 97 6 97 96 97 97 6 97 97 6 97 97
700 800 6 80 800 80 800 6 80 800 6 80 800
800 1808 1506 1506 1411 1811 1610 1806 3412 3109 3308 3509 3412
    1811 2302 1713 3514
CDC 87070100
100 89 91      89 54 54      50 88 90      89 55 55
200 10 10     89 0 0     0 0 0 0
300 3000000 3000000 3000000
400 0 0
500 221 221 221
600 97 6 97 97 97 97 6 97 97 6 97 97
700 800 6 80 800 80 800 6 80 800 6 80 800
800 1707 0000 1307 1307 2115 2114 2315 2315 2115 2114 2410 2212
    2110 2302 3213 3213
```

Figure 6. Example cccVERccc product which is transmitted to NMC.

SDFMSGVER

```
AFOS-ERA VERIFICATION DIAGNOSTICS
!! VERIFY START CYCLE 11 02 1200
NO KEY FOUND - SDFSSMSDF
DECODE ERROR 4 - SDFSAOSDF 11 02 1847
16 NEW SAO(S) ADDED TO VOBSSDF
QUESTIONABLE OR MISSING VALUE(S) FOUND FOR SNOW AMOUNT ON PAGE 2 OF SDFPVMSDF
22 NEW SAO(S) ADDED TO VOBSEX
WARNING: NON-DIURNAL TEMPERATURE TRACE FOUND ON 11/02 AT LEX
USING TEMPERATURE OF 54 AS A BEST GUESS OF THE NIGHTTIME LOW
QUESTIONABLE OR MISSING VALUE(S) FOUND FOR WINDS ON PAGE 5 OF SDFPVMLEX
QUESTIONABLE OR MISSING VALUE(S) FOUND FOR WINDS ON PAGE 4 OF SDFAVMLEX
QUESTIONABLE OR MISSING VALUE(S) FOUND FOR CEILING ON PAGE 5 OF SDFAVMLEX
DATA TRANSMITTED FOR CYCLE 10 28 1200
!! VERIFY COMPLETE
```

PAGE 01

Figure 7. Example cccMSGVER product which consists of messages (including error conditions) that provide information regarding the completion status of VERIFY.

VERCREAT

MAIN PROGRAM

VERCREAT

SUBROUTINES

None

LOAD LINE

RLDR VERCREAT UTIL.LB FORT.LB

Figure 8. Software structure and load line for program VERCREAT.

```

EXFMCPMEF
WOUS00 KEX1 999999
FORECAST CYCLE(MMDDHH) 052212          AVIATION FORECASTER 13
STATION SAT              12H           18H           24H           30H           36H           42H
PRECIPITATION TYPE              3              3              3              3              3
SNOW AMOUNT                      00
CLOUD AMOUNT              3              2              2
SIGNIFICANT WINDS(Y/N)                                N

STATION IAH              12H           18H           24H           30H           36H           42H
PRECIPITATION TYPE              3              3              3              3              3
SNOW AMOUNT                      00
CLOUD AMOUNT              3              3              3
SIGNIFICANT WINDS(Y/N)                                Y

STATION BRO              12H           18H           24H           30H           36H           42H
PRECIPITATION TYPE              3              3              3              3              3
SNOW AMOUNT                      00
CLOUD AMOUNT              2              2              2
SIGNIFICANT WINDS(Y/N)                                N

PRECIP TYPE: 1=FREEZING 2=FROZEN 3=LIQUID   SNOW AMT: INCHES
CLOUD AMT: 1=CLR 2=SCT 3=BKN 4=OBS/OVC     SIG WINDS: N=LT 22KTS Y=GE 22KTS [ ]
                                           PAGE 01
  
```

Figure 9. Example cccMEFccc product which contains manually entered forecasts.



VERIFY

MAIN PROGRAM

VERIFY

SUBROUTINES

VEREV

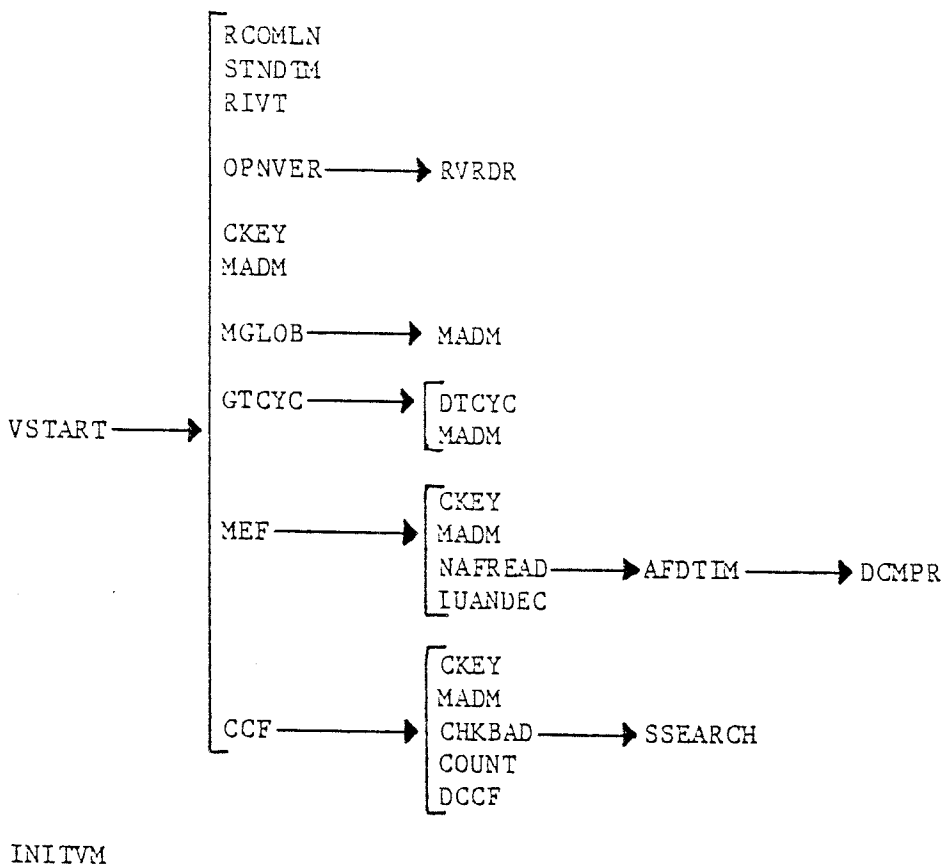

Figure 10. Software structure and load line for program VERIFY (continued on next page).

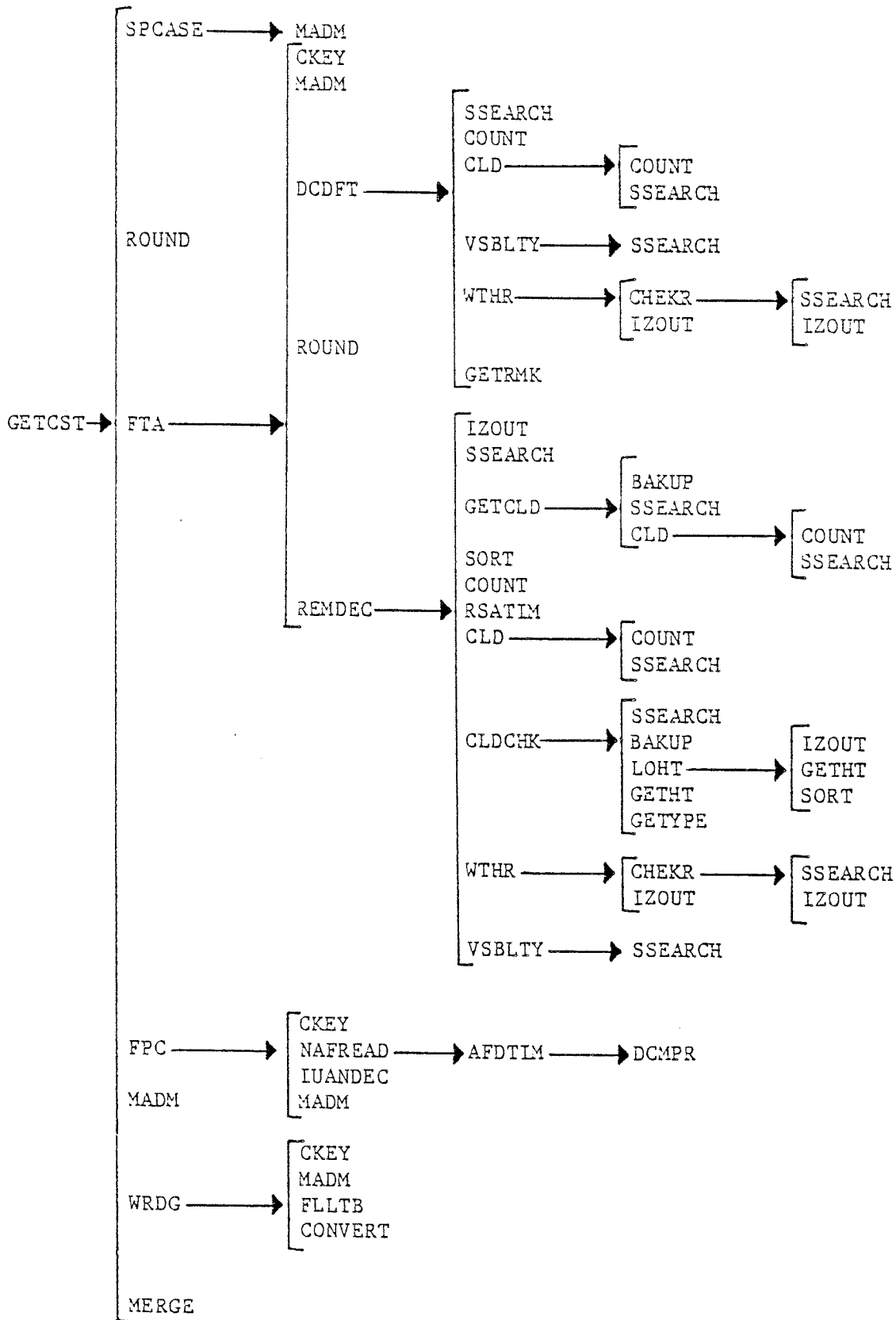

Figure 10. (continued).

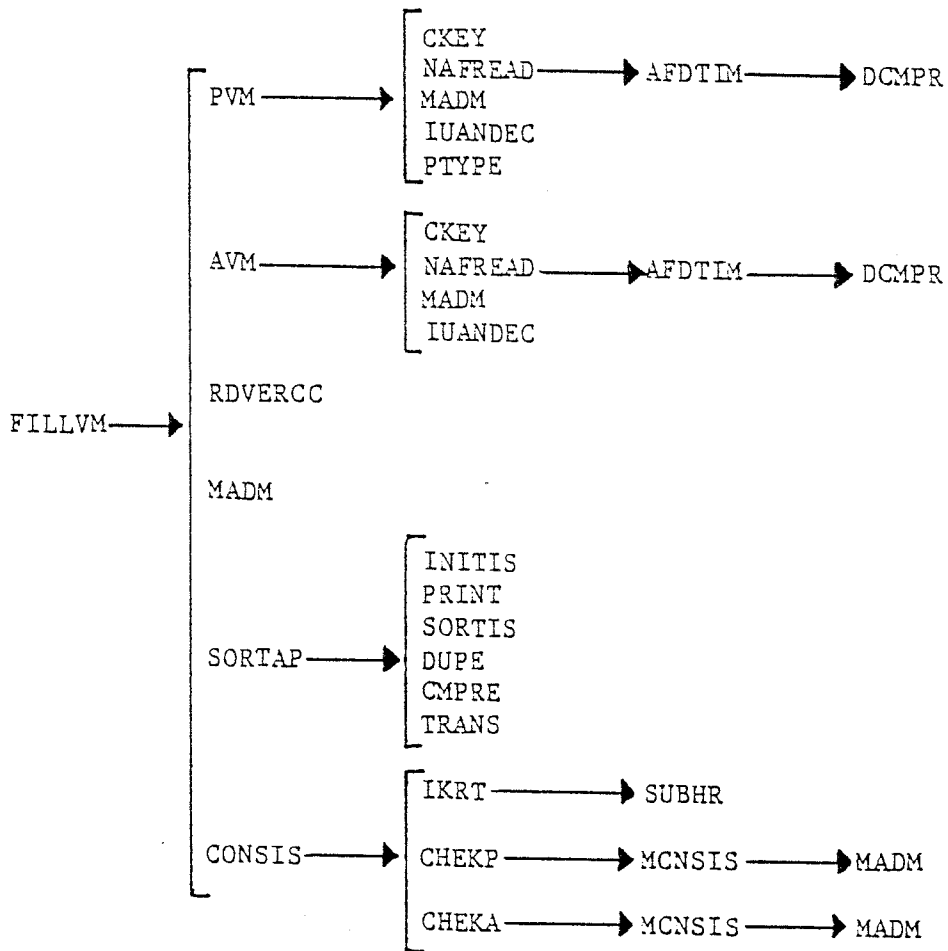

Figure 10. (continued).

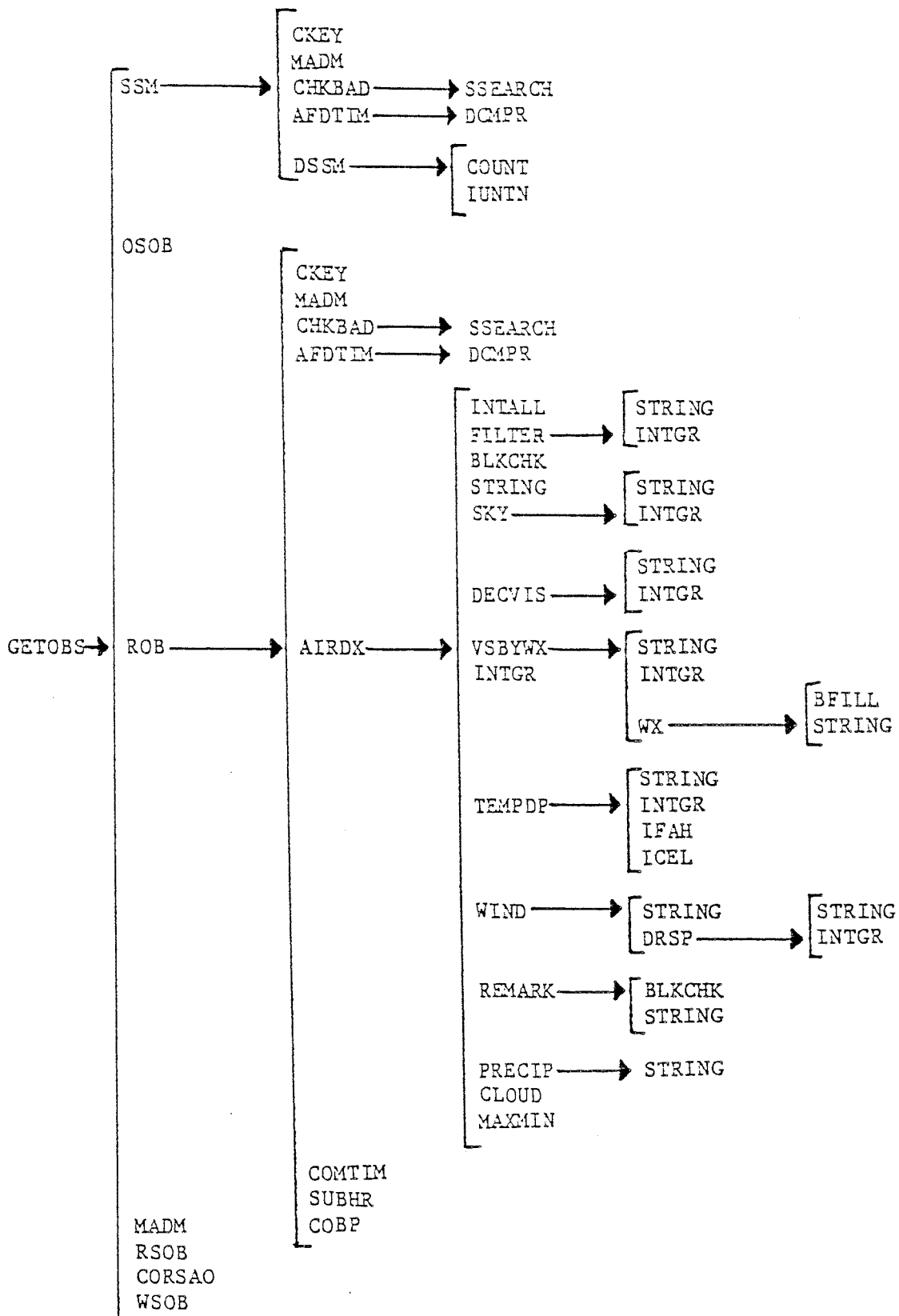

Figure 10. (continued).

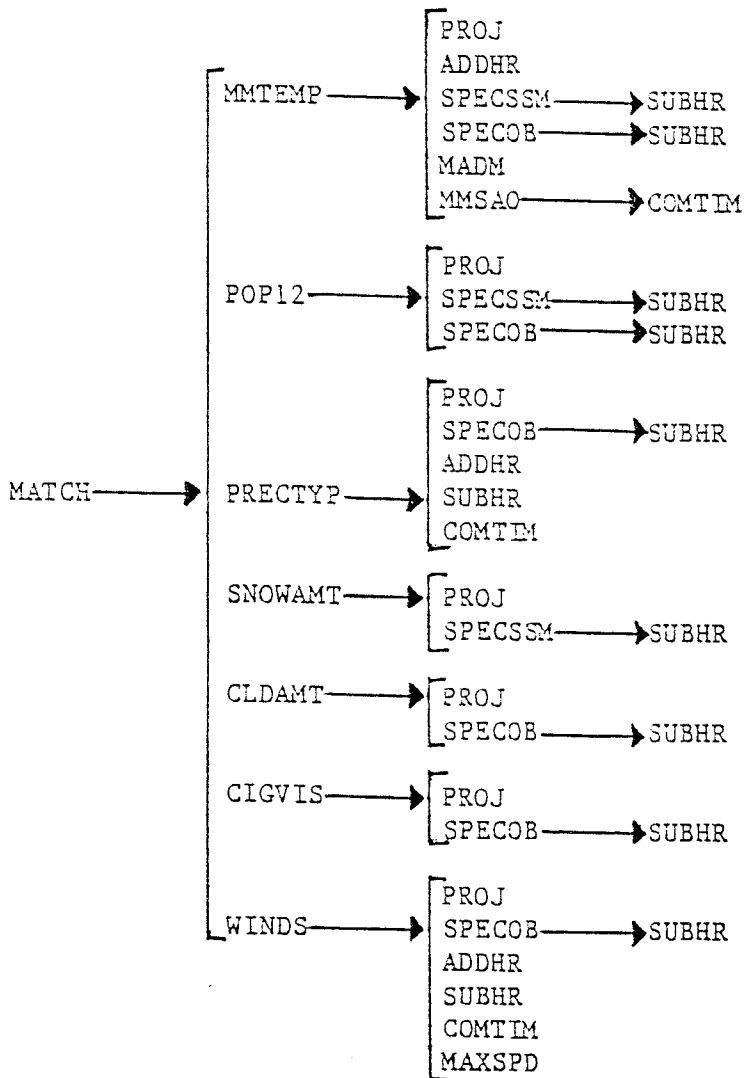
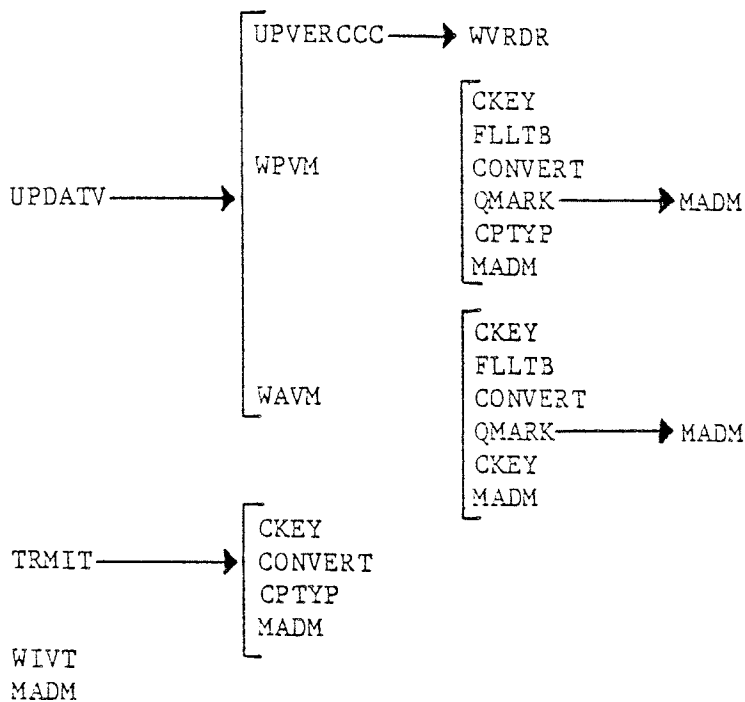

Figure 10. (continued).



LOAD LINE

```

RLDR VERIFY VEREV
[VSTART FILLVM NAFREAD IUANDEC, FTA CLD VSBLTY WTHR CHEKR IZOUT,
ROB FILTER STRING COBP COMTIM, UPVERCCC WVRDR TRMIT WIVT QMARK CPTYP]
[RCOMLN RIVT OPNVER RVRDR MGLOB GTCYC DTCYC MEF CCF DCCF,
SPCASE DCDFT GETRMK FPC MERGE,
REMDEC CLDCHK GETCLD RSATIM SORT BAKUP GETHT GETYPE LOHT,
INITVM PVM PTYPE AVM RDVERCC CONSIG IKRT CHEKP CHEKA MCNSIS,
SORTAP SORTIS INITIS TRANS DUPE CMPRE PRINT SSM IUNTN DSSM
OSOB RSOB WSOB CORSAO,
AIRDX INTGR CLOUD PRECIP SKY VSBYWX BLKCHK WIND TEMPDP DRSP REMARK
DECVIS WX MAXMIN INTALL IFAH ICEL BFILL POBS,
MATCH MMTEMP MMSAO POP12 PRECTYP SNOWAMT CLDAMT CIGVIS
WINDS PROJ SPECOB SPECSSM MAXSPD ADDHR,
WRDG WPVM WAVM FLLTB CONVERT]
GETCST GETOBS UPDATV SUBHR AFDTIM DCMPR SSEARCH COUNT CKEY CHKBAD MADM
STNDTM ROUND
UTIL.LB BG.LB FORT.LB
  
```

NOTE: THE FOLLOWING ROUTINES REQUIRE FPAFOS.FR DURING COMPILATION: CCF, FTA, SSM, WRDG, WAVM, WPVM.

Figure 10. (continued).

## APPENDIX I

### Description of VERccc File

The following information explains the data in the VERccc file (see Table 4). In many cases, to conserve space, two values are stored in one word. In these cases, the first value uses the upper 8 bits and the second uses the lower 8 bits. If a datum is missing, all bits in the field are set to one. For a full word field (16 bits), this corresponds to a -1 decimal or 177777 octal. For a one byte field (8 bits), the value is a 377 octal.

#### A. Station/Cycle Information

Station call letters - the AFOS assigned station call letters.

Year/month - last 2 digits of the year multiplied by 100 plus the month of the year.

Day/cycle - day of the month multiplied by 100 plus the cycle number (00 or 12) for the forecast being made.

Public forecaster number/aviation forecaster number - public forecaster number multiplied by 100 plus the aviation forecaster number.

FT offset time - difference in hours and minutes (HHMM) between the cycle time and the FT valid time. The FT offset time is calculated for each cycle using the time zone of the WSFO and whether daylight or standard time is in effect. To determine the FT valid time for each cycle, add the FT offset time to the cycle time.

#### B. Max/Min Temperature

MOS and local forecasts are for daytime max/overnight min temperature. The verifying observations are deduced via a comprehensive algorithm that examines reported max/min and hourly temperatures. Daytime is defined as 0700-1900 LST, and overnight as 1900-0800 LST. The highlights of the algorithm are described as follows. The 24-h max (min) temperature reported in the SAO's at 0600 (1800) GMT is compared with the 12-h max (min) temperature reported at 0000 (1200) GMT. If the values are identical, the 24-h max (min) temperature is inserted as the daytime max (overnight min) temperature, since the extreme occurred during the desired time period. If the 24-h max (min) is greater (less) than the 12-h max (min), then the hourly temperatures are checked to determine if the temperature followed a normal diurnal cycle. If the cycle is diurnal, then the 24-h max (min) is again used since the extreme must have occurred after the 12-h max (min) report but within the daytime (overnight) period. If the cycle is nondiurnal, then the greater (lesser) of the 12-h max (min) or highest (lowest) hourly temperature within the desired time period is recorded as the daytime max (overnight min) temperature. If a max/min temperature cannot be obtained for the comparison from the SAO's, then it is extracted from the SSM's if available.

The option exists to use city temperatures in deriving the verifying observation (see the section on Switches). A switch in the software is available to enable stations to use city reports if the local max/min temperature forecast made for the city, is climatologically inconsistent with airport reports. The algorithm is performed on the city reports to deduce the daytime max or overnight min temperature. The calendar day city max (18-h city min) reported in the SSM's at 1200 (0000) GMT is compared with the 12-h city max (min) reported at 0000 (1200) GMT. The type of checks made are the same as for the airport reports; hourly city temperatures reported in the SAO's are used to deduce if the cycle is diurnal.

Forecast and observed temperatures are recorded in whole degrees Fahrenheit plus 100. For example, 53°F is coded as 153.

C. 12-h PoP

MOS and local forecasts are given in percent rounded to the nearest tens of percent. For MOS there are also 2 and 5 percent forecasts. The observed precipitation amount is in hundredths of inches. For example, 3.15 inches is coded as 315. A trace is coded as a minus 2. Observed amounts are the sum of two 6-h amounts reported in the SAO's: the sum of the 1800 GMT and 0000 GMT reports for the 12-h period ending at 0000 GMT, and the sum of the 0600 GMT and 1200 GMT reports for the 12-h period ending at 1200 GMT. If precipitation amounts are unavailable from SAO's, they are extracted from synoptic reports, if possible. If either 6-h period is missing from both the SAO and the synoptic observation, the 12-h precipitation amount is reported as missing.

D. Precipitation Type

MOS and local forecasts for type of precipitation are recorded as 1, 2, or 3 for freezing, frozen, and liquid precipitation, respectively. MOS forecasts are available during the cool season only (September 16-April 30). There are two verifying values archived for each forecast projection. The first is type(s) of precipitation reported in the routine surface observation at the verifying hour. The second is a composite of precipitation type(s) reported in routine and special observations from the routine observation at an hour before the verifying hour to the routine observation at an hour after the verifying hour. The format of the word to store these two verifying values is shown below.

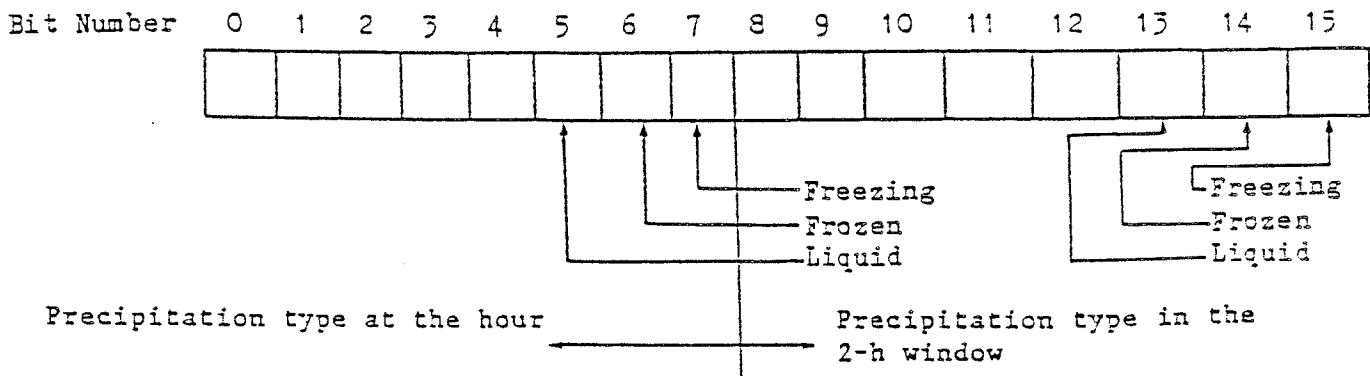



If a type of precipitation is reported, the corresponding bit is set to one. It is possible to have from 0 to 3 bits set in a field. For example, if the observation(s) reported ZR and R, then the freezing bit and liquid bit are set. If no precipitation is reported, all bits are zero. If either (or both) values are missing, all 8 (16) bits in the field are set to one.

The categories for freezing, frozen, and liquid precipitation are defined as follows:

Freezing	Frozen	Liquid
ZL, ZR	IC IP, IPW S, SG, SP, SW	L R, RW

#### E. 12-h Snow Amount

MOS forecasts are categorical. The categories are defined as follows:

Category	Snow Amount (inches)
0	$\leq 1$
2	2-3
4	4-5
6	$\geq 6$

MOS forecasts are available during the cool season only (September 16-April 30). Local forecasts and observed snow amount are entered in whole inches. The observed amount for the 0000 GMT cycle is the sum of the amounts reported in the 1800 GMT and 0000 GMT synoptic reports. For the 1200 GMT cycle, the 0600 GMT and 1200 GMT reports are used. If either 6-h period is missing, the 12-h snow amount is set to missing.

#### F. Cloud Amount

The forecasts and observed values are coded as 4 categories. The categories are defined as follows:

1	CLR, -X, -SCT, -BKN, -OVC
2	SCT
3	BKN
4	X, OVC

Observed values are coded from the routine surface observation at the verifying hour.

#### G. Ceiling Height\*

MOS forecasts are categorical. The categories are defined as follows:

1	< 200
2	200-400
3	500-900
4	1000-2900
5	3000-7500
6	> 7500

Local forecasts and observed ceiling heights are given in hundreds of feet with 96 for a ceiling above 9000 feet and 97 for an unlimited ceiling. Observed ceiling heights are taken from the routine surface observation at the verifying hour.

#### H. Visibility\*

MOS forecasts are categorical. The categories are defined as follows:

1	< 1/2
2	1/2-7/8
3	1-2 3/4
4	3-4
5	5-6
6	> 6

Local forecasts are two digits in which the first is miles and the second is quarters of miles. Visibilities over 7 miles are coded as 80. Observed visibilities are given in hundredths of miles up to 7 miles. Visibilities over 7 miles are coded as 800. Observed visibilities are taken from the routine surface observation at the verifying hour.

#### I. Wind Direction and Speed\*

MOS and local forecasts and observed directions and speeds are given in tens of degrees/knots. If the speed exceeds 100 knots, the tens and units digits are given and 50 is added to the direction. Note that the local 42-h wind forecast is limited, however, to only two values: 2422 for significant wind and 2402 for nonsignificant wind. A threshold of 22 kt determines significance.

Two verifying values are archived for each forecast projection. The first is the wind reported in the routine surface observation at the verifying hour. The second is the highest sustained wind reported in routine and special observations from the routine observation at 3 hours before the verifying hour to the routine observation at 3 hours after the verifying hour.

\* NOTE: For the aviation elements (ceiling, visibility, and wind direction and speed), the MOS forecast projections will not match the local forecast and observations projections. The MOS projections (12-, 15-, 18-, and 24-h) are relative to the cycle time (0000 GMT or 1200 GMT). The verifying projections for the local aviation forecast (0-, 3-, 6-, 9-, and 15-h) and observations are relative to the FT valid time, which varies with time zone and changes from daylight to standard time (or vice versa). For this reason, the MOS data are not included in the AVM product. However, they are available in both the VERccc and the cccVERccc.

APPENDIX II

VERIFY Error Conditions

MESSAGE

1- "DECODE ERROR N..."

MEANING

The product cannot be decoded. N identifies the type of error. Correct the error and rerun; or enter the correct data for the product into the PVM and AVM. Action is not required if the product is not used in the PVM or AVM.

FTA Product

- N = 1 FT is delayed.
- 2 Unable to find issue date/time field.
- 3 More time groups than allowed.
- 4 Unable to find valid time of forecast group.
- 5 Unknown number field of length greater than 4.
- 6 Invalid wind field.
- 7 Invalid gust field.
- 8 FT too long.

FTA Product Remark

- N = 1 Remark decoded with at least one error.
- 2 Remark decoded with at least one error and truncated.
- 3 Unable to decode due to excessive errors.
- 4 Same as above but remark came in truncated.
- 5 Remark decoded, but truncated.

SSM Product

- N = -1 Invalid block/station number group.
- 2 Unable to find date/time in text header.
- 3 Problem in the mandatory group containing the precip indicator. Not a five-character group.
- 4 Invalid precip indicator field.
- 5 Problem in a supplementary group. Not a five-character group.

- 6 Sign of max temperature is not a zero (for positive temperatures and zero) or a one (for negative temperatures).
- 7 Sign of min temperature is not a zero or a one.

SAO Product

- N = -4 Fatal decoding error - no call sign.
- 3 Fatal decoding error - obscure end of observation.
- 2 Fatal error in WMO header.
- 0 Fatal error - too many missing values.
- 2 File read error for ccc.
- 3 No appropriate time version.
- 4 Observation type could not be identified.
- 5 Observation time could not be identified.

CCF Product

- N = 1 Can't find the beginning of the forecast line in the product.

2- "UNABLE TO PROCESS THIS CYCLE YET..."

The 0000 GMT cycle cannot be processed until 0930 GMT of the same day in all time zones except the Pacific time zone during standard time (PST). During PST, the 0000 GMT cycle cannot be processed until after the 1100 GMT FT has been issued. The 1200 GMT cycle cannot be processed until 2130 GMT of the same day in all time zones. Wait until the proper time and rerun.

3- "NO KEY FOUND..."

The key for this product is not stored in the AFOS database. Add the key and rerun.

4- "NO DATA...CHECKING VERCCC FOR DATA"

The product is missing or cannot be read. The RDOS file VERccc is being used as a backup to retrieve the data, if available. Check the product.

5- "TROUBLE READING PRODUCT... CHECKING VERCCC..."

The product is not in the correct format. The RDOS file VERccc is being used as a backup to retrieve the data. Check the product.

- 6- "BAD DATA...CHECKING  
VERCCC..."  
The product contains data which have been shifted out of position. The RDOS file VERccc is being used as a backup to retrieve the data. Check the product; data which had been edited may need to be edited again.
- 7- "INCONSISTENT CYCLES  
BETWEEN AVM & PVM FOR  
..., CHECKING VERCCC  
FOR DATA"  
The cycle times stored in the PVM and AVM products do not correspond. The RDOS file VERccc is being used as a backup to retrieve the data. Check the products; data which had been edited may need to be edited again.
- 8- "TOO MANY CYCLES...  
CHECKING VERCCC FOR DATA"  
The number of cycles stored in the product exceeds the maximum number allowed. The RDOS file VERccc is being used as a backup to retrieve the data. No action is required.
- 9- "PRODUCT TOO LARGE..."  
The product size exceeds the maximum number of blocks allowed for it. Reduce the size of the product and rerun.
- 10- "READING BLOCK..."  
or  
"ERROR READING PRODUCT..."  
A block of the product cannot be read. Check the product, correct any errors, and rerun.
- 11- "REQUESTED VERSION NOT  
FOUND..."  
The version of the product which corresponds to the VERIFY cycle time cannot be found. Store the requested version and rerun.
- 12- "UNEXPECTED END OF  
TRANSMISSION..."  
The product ends in an unusual location. Check the product, correct any errors, and rerun.
- 13- "CAN'T FIND STATION  
NAME..."  
The station name cannot be found within the product as expected. Check the product, correct any errors, and rerun.
- 14- "FORECAST FOR STATION  
... NOT FOUND IN ...  
PRODUCT"  
The forecast for this station is not contained in the specified product as expected. Correct the product and rerun or enter the forecast directly into the PVM or AVM.
- 15- "NO TIME GROUPS..."  
The product does not contain needed time groups. Correct the error and rerun; or enter the correct data for the product into the PVM or AVM.

- 16- "IDENTICAL TIME PERIODS..." The product contains two or more groups with identical time periods. Correct the error and rerun; or enter the correct data for the product into the PVM or AVM.
- 17- "ERROR IN STORING PRODUCT..." Data from an RDOS file have not been successfully stored in an AFOS product. Check both the file and the product (including the product key), correct any errors, and rerun.
- 18- "ILLEGAL START CYCLE..." The cycle specified with the override switch is not possible. Rerun using the correct MMDDCC with the switch.
- 19- "24 HR...TEMPERATURE OF...  
REPORTED IN THE...IS NOT  
CONSISTENT WITH THE 12 HR...  
TEMP OF...REPORTED IN THE..." The two observed temperatures were compared as part of the algorithm which deduces the observed daytime max/overnight min temperature. The algorithm could not continue due to an apparent error in at least one of the observations. Correct the error and rerun, or enter the correct temperature in the PVM.
- 20- "WARNING: NON-DIURNAL  
TEMPERATURE TRACE FOUND ON..." The algorithm which deduces the observed daytime max/overnight min temperature scanned the hourly temperatures and found the trace was nondiurnal. The daytime max/overnight min temperature was estimated and placed in the PVM. Check the value and replace it if incorrect.
- 21- "QUESTIONABLE OR MISSING  
VALUE(S) FOUND FOR..." A forecast or observation in the PVM or AVM is missing or suspect. Each missing or questionable value is flagged with a question mark in the PVM or AVM. Find each question mark and enter the value if missing, or correct the value if in error.
- 22- "OB OF ... FOR ... HR  
PROJ OF ... ON ... Z  
IS INCONSISTENT WITH OB  
OF ... FOR ... HR PROJ  
OF ... ON ... Z AT ..." The same observation has conflicting values for different cycles in the PVM or AVM. This error can only result from incorrectly editing these products. Replace the erroneous value in the PVM or AVM.
- 23- "ERROR READING ... FILE" The VERIT, VERDIR, or VERccc file is missing or cannot be read. Check the location of the file (it must be on, or linked to, the master directory) and rerun.

