

RESEARCH ARTICLE

A rapid high-precision analytical method for triple oxygen isotope analysis of CO₂ gas using tunable infrared laser direct absorption spectroscopy

Nathan Perdue^{1,2} | Zachary Sharp¹  | David Nelson³ | Rick Wehr³ | Christoph Dyroff³

¹Department of Earth and Planetary Sciences, The Center for Stable Isotopes, University of New Mexico, Albuquerque, New Mexico, USA

²PerkinElmer, Inc., Waltham, Massachusetts, USA

³Aerodyne Research Inc., Billerica, Massachusetts, USA

Correspondence

Z. Sharp, Department of Earth and Planetary Sciences, The Center for Stable Isotopes, University of New Mexico, 200 Yale Boulevard, Albuquerque, NM 87131.
Email: zsharp@unm.edu

Funding information

National Science Foundation, Grant/Award Number: EAR 2025107; NOAA, Grant/Award Number: SBIRgrant#WC-133R-15-CN-0086

Rationale: The simultaneous analysis of the three stable isotopes of oxygen—triple oxygen isotope analysis—has become an important analytical technique in natural sciences. Determination of the abundance of the rare ¹⁷O isotope in CO₂ gas using magnetic sector isotope ratio mass spectrometry is complicated by the isobaric interference of ¹⁷O by ¹³C (¹³C¹⁶O¹⁶O and ¹²C¹⁶O¹⁷O, both have mass 45 amu). A number of analytical techniques have been used to measure the ¹⁷O/¹⁶O ratio of CO₂ gas. They either are time consuming and technically challenging or have limited precision. A rapid and precise alternative to the available analytical methods is desirable.

Methods: We present the results of triple oxygen isotope analyses using an Aerodyne tunable infrared laser direct absorption spectroscopy (TILDAS) CO₂ analyzer configured for ¹⁶O, ¹⁷O, and ¹⁸O combined with a custom gas inlet system. We evaluate the sensitivity of our results to a number of parameters. CO₂ samples with a wide range of δ¹⁸O values (from −9.28‰ to 39.56‰) were measured and compared to results using the well-established fluorination-gas source mass spectrometry method.

Results: The TILDAS system has a precision (standard error, 2σ) of better than ±0.03‰ for δ¹⁸O and ±10 per meg for Δ¹⁷O values, equivalent to the precision of previous analytical methods. Samples as small as 3 μmol CO₂ (equivalent to 300 μg CaCO₃) can be analyzed with a total analysis time of ~30 min.

Conclusions: We have successfully developed an analytical technique for the simultaneous determination of the δ¹⁷O and δ¹⁸O values of CO₂ gas. The precision is equal to or better than that of existing techniques, with no additional chemical treatments required. Analysis time is rapid, and the system is easily automated so that large numbers of samples can be analyzed with minimal effort.

This is an open access article under the terms of the [Creative Commons Attribution-NonCommercial-NoDerivs](https://creativecommons.org/licenses/by-nc-nd/4.0/) License, which permits use and distribution in any medium, provided the original work is properly cited, the use is non-commercial and no modifications or adaptations are made.

© 2022 The Authors. *Rapid Communications in Mass Spectrometry* published by John Wiley & Sons Ltd.

1 | INTRODUCTION

After the discovery of the temperature-dependent fractionation between calcite and water over 70 years,¹ numerous studies have used this relationship as a paleoclimate indicator to reconstruct ocean water temperatures. Despite the prevalence of measuring carbonates to reconstruct temperatures, researchers are still trying to develop new techniques to minimize the assumptions associated with carbonate palaeothermometry. These assumptions include the following: the original oxygen isotope composition of the ocean, the carbonate formed in oxygen isotope equilibrium with ocean water, and the carbonate is free of diagenetic alteration.²

New carbonate isotope techniques have been developed, including for clumped isotopes³ and triple oxygen isotopes.⁴ The relatively new field of triple oxygen isotopes for carbonates uses the rare stable isotope of oxygen, ¹⁷O, in addition to the traditional measurements of ¹⁸O and ¹⁶O, to evaluate the equilibrium conditions under which the carbonates precipitated. For terrestrial processes, oxygen isotopes undergo mass-dependent fractionations such that $\delta^{17}\text{O} \approx 0.5(\delta^{18}\text{O})$, where $\delta^x\text{O} = (R_{\text{sample}}/R_{\text{standard}} - 1) \times 1000$ in per mil (‰) notation and R is ¹⁷O/¹⁶O or ¹⁸O/¹⁶O. Because the $\delta^{17}\text{O}$ and $\delta^{18}\text{O}$ values of terrestrial materials are generally plotted with a slope of 1/2, it was assumed that the $\delta^{17}\text{O}$ value provided no additional information to the $\delta^{18}\text{O}$ value alone. It is now known that the $\delta^{17}\text{O}$ and $\delta^{18}\text{O}$ values of terrestrial materials deviate slightly from this near-linear relationship and that these deviations have geological or biological significance. Triple oxygen isotope data are presented in terms of $\Delta^{17}\text{O}$ (also called ¹⁷O excess), which are defined as follows:

$$\Delta^{17}\text{O} = (\delta^{17}\text{O} - \lambda \times \delta^{18}\text{O}) \quad (1)$$

in per mil (‰) notation and

$$\Delta^{17}\text{O} = (\delta^{17}\text{O} - \lambda \times \delta^{18}\text{O}) \times 1000 \quad (2)$$

in per meg notation, where λ is a reference slope (0.528 in this work) and $\delta^{17}\text{O}$ and $\delta^{18}\text{O}$ are linearized versions of $\delta^{17}\text{O}$ and $\delta^{18}\text{O}$ ($\delta^x\text{O} = 1000 \ln(\delta^x\text{O}/1000 + 1)$).⁵ The small but measurable $\Delta^{17}\text{O}$ values provide meaningful information on carbonates and other minerals.^{4,6-8}

The benefit of measuring both $\delta^{17}\text{O}$ and $\delta^{18}\text{O}$ of carbonates becomes apparent when plotted in triple oxygen isotope space with the carbonate–water isotope equilibrium curve.⁸ The triple oxygen isotope composition of marine carbonates can be used to assess the degree of postdepositional diagenesis and to estimate the temperature of deposition.⁸ Therefore, the triple oxygen isotope composition of carbonates provides us with an independent estimate of temperature and the ability to assess the preservation of a sample.

The development and wide usage of high-precision triple oxygen isotope measurements of carbonates ($\Delta^{17}\text{O} \pm 10$ per meg) is hindered by the difficulty using current available analytical techniques. Traditional measurements of carbonates for $\delta^{13}\text{C}$ and

$\delta^{18}\text{O}$ are made from CO₂ produced by phosphoric acid digestion.⁹ However, due to the isobaric interference at mass 45 between ¹³C¹⁶O₂ and ¹²C¹⁷O¹⁶O, the ¹⁷O contribution to CO₂ at mass 45 cannot be determined using conventional magnetic sector mass spectrometry. A number of techniques have been developed to overcome this problem, including the following: (a) high-temperature fluorination of CO₂ to O₂, which is then analyzed in a conventional gas source mass spectrometer¹⁰; (b) conversion of CO₂ to H₂O using Fischer–Tropsch process followed by fluorination of the resultant H₂O to O₂^{6,11}; (c) high-temperature Pt-catalyzed exchange between CO₂ and subordinate O₂ gas, in which the O₂ gas essentially “acquires” the isotopic composition of the CO₂ gas^{12,13}; and (d) analysis of the O⁺ fragment of CO₂ gas in an electron impact source ultrahigh-resolution mass spectrometer.¹⁴ None of these methods is ideal for measuring relatively large numbers of samples due to cost, time of analysis, or limited precision. See Passey and Levin¹⁵ for a full review.

New developments using laser-based spectrometry show significant progress toward high-precision triple oxygen isotope measurements directly from CO₂. Previous studies using tunable infrared laser direct absorption spectroscopy (TILDAS) have successfully measured ¹⁷O/¹⁶O and ¹⁸O/¹⁶O of CO₂ simultaneously but have not yet achieved the precision required for application to natural materials (~10 per meg for $\Delta^{17}\text{O}$).^{16,17}

Here we report the simultaneous analyses of ¹⁷O/¹⁶O and ¹⁸O/¹⁶O of CO₂ through the development of a new TILDAS instrument for high precision and rapid analysis of triple oxygen isotope composition. To obtain high-precision results, it is necessary to rapidly (on the order of 1–2 min) switch between the sample and reference gas (to calibrate drift), and it is critical to balance the mixing ratios and pressures of the sample and reference gases. A sample preparation system was constructed to meet these objectives. This new instrument and the sampling system significantly reduce the analysis time and sample size while achieving the necessary precision of 10 per meg for $\Delta^{17}\text{O}$. The cost of the triple oxygen CO₂ analyzer and the sampling system is less than that of a traditional mass spectrometer required to acquire such precision. The rapidity and ease of analysis, combined with the potential for full automation, allow for large numbers of samples to be analyzed with reasonable effort, opening up the technique to numerous applications in the physical sciences.

2 | EXPERIMENTAL

2.1 | Tunable infrared laser direct absorption spectroscopy

Spectroscopic analyses were performed using a TILDAS CO₂ isotope monitor for $\Delta^{17}\text{O}$ –CO₂ designed and manufactured by Aerodyne Research, Inc. (ARI, Billerica, MA, USA), configured for triple oxygen isotope analyses of CO₂. The TILDAS instrument uses a mid-infrared distributed-feedback interband-cascade laser (Nanoplus Nanosystems

and Technologies GmbH) tuned to sweep a 0.4 cm^{-1} wide spectral region near 2349 cm^{-1} to measure the absorption of CO_2 isotopologues 628 ($\text{C}^{12}\text{O}^{18}\text{O}^{16}$), 627 ($\text{C}^{12}\text{O}^{17}\text{O}^{16}$), and

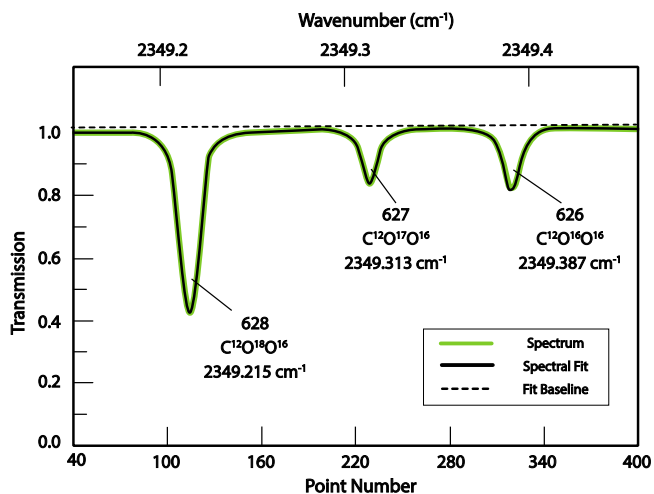

FIGURE 1 Sample CO_2 triple oxygen isotope spectrum. Measured (green) and fitted-model (black) transmission spectrum from the TILDAS (tunable infrared laser direct absorption spectroscopy) triple oxygen isotope analyzer for CO_2 [Color figure can be viewed at [wileyonlinelibrary.com](https://onlinelibrary.wiley.com)]

626 ($\text{C}^{12}\text{O}^{16}\text{O}^{16}$) (Figure 1). The notations 628, 627, and 626 used here follow those of the atmospheric database for high-resolution transmission molecular absorption.¹⁸

Analyses of the three stable isotopes of oxygen directly from CO_2 are possible using laser spectroscopy due to the well-determined spectral lines for each isotopologue, which result from their highly characteristic rotational-vibrational bands.¹⁹ Laser light is absorbed only when the frequency of the laser closely matches the absorption frequency of a CO_2 isotopologue, and the amount of absorption is proportional to the concentration of that isotopologue, per Beer-Lambert law²⁰:

$$A = L \times N \times \alpha \quad (3)$$

where A is the absorbance, L is the path length of the laser within the absorption cell 36 m,²¹ N is the concentration of the isotopologue, and α is the absorption coefficient, which differs for each isotopologue and the spectral region. The narrow spectral region of the laser was selected by ARI to include one well-determined spectral line for each isotopologue, all with similar absorbances at ambient concentrations (Figure 1).

The TILDAS instrument uses a scan rate of 2.4 kHz and averages the 2400 spectra acquired each second. The laser frequency is swept across the spectral region by ramping the electrical current supplied

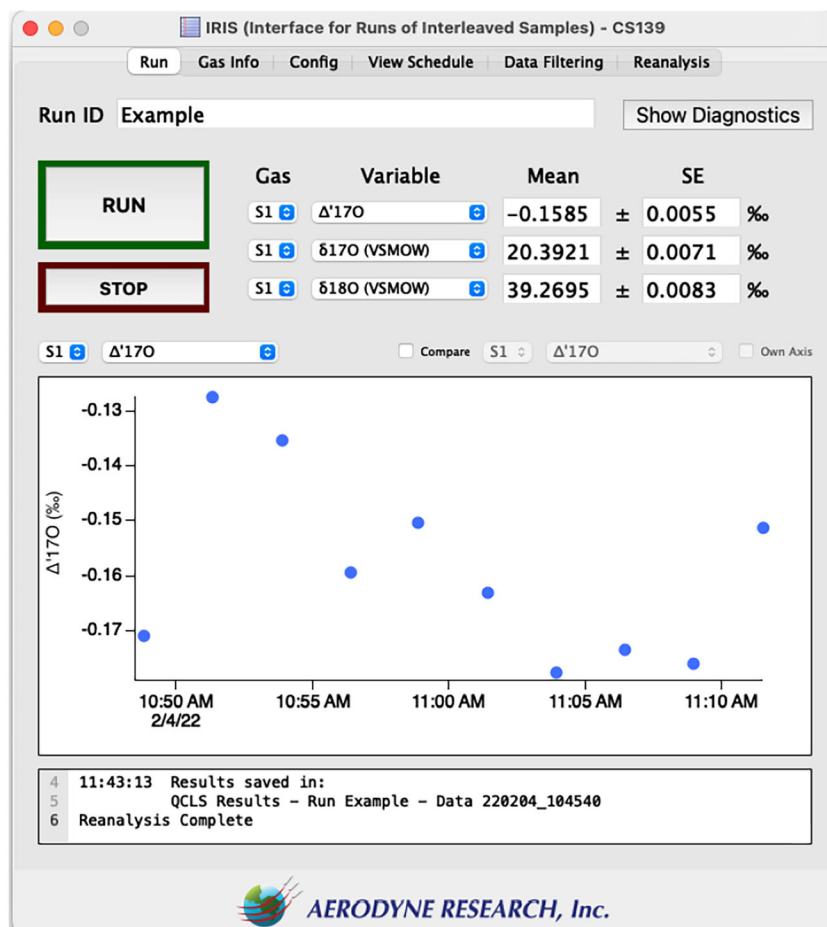

FIGURE 2 TILDAS (tunable infrared laser direct absorption spectroscopy) user interface. Sample image of the TILDAS user interface run in IgorPro. The user interface communicates with TDL Wintel, providing sampling system automation and real-time data analysis [Color figure can be viewed at [wileyonlinelibrary.com](https://onlinelibrary.wiley.com)]

to the laser, and the temperature of the laser is maintained within 0.005 K by thermoelectric coolers and a recirculating liquid chiller (Oasis T-Three Thermoelectric Chiller, Martinsried, Germany). The light signal is detected using a thermoelectrically cooled photovoltaic (HgCdTe) detector whose zero level is calibrated by briefly turning the laser off at the end of each sweep.

CO₂ absorbs the laser beam in an absorption cell where the laser beam bounces 182 times between two astigmatic mirrors to lengthen the absorption path and thereby increase sensitivity. Most ARI TILDAS instruments have a flow-through absorption cell that provides continuous monitoring of air. In the present configuration, the absorption cell was designed for discrete sampling: the cell was evacuated, filled with the sample or reference gas, and sealed for 30 s while the spectrum was measured. In this configuration, gas entered and exited the absorption cell through a single port to minimize the required sample volume. The optics outside the absorption cell (i.e., mirrors) were thermally stabilized and purged with nitrogen at a constant flow rate of 1 L/min to prevent any absorption of the laser light by CO₂ outside of the absorption cell.

Spectrometer control and data acquisition were performed using TDL Wintel, a dedicated piece of software produced by ARI to run all its TILDAS instruments. A separate graphical user interface called IRIS, created by ARI for discrete sampling applications, coordinated with TDL Wintel to automate the inlet system and perform real-time $\Delta^{17}\text{O}$ analysis (Figure 2). IRIS runs within the Igor Pro computing environment (Wavemetrics, Inc., Portland, OR, USA).

More details about the spectrometer design can be found in McManus et al.²² and Wang et al.,²³ which describe nearly identical instruments used for other isotopologues.

2.2 | Preparation of CO₂ from carbonate samples

Carbonates were converted to CO₂ using the well-established phosphoric acid digestion system.⁹ The minimum sample required for the present system was $\sim 3 \mu\text{mol CO}_2$, corresponding to 300 μg calcite. (For testing the precision of the TILDAS instrument, large samples [3 mg calcite] were reacted to minimize errors associated with the CO₂ extraction step. The gas was then cut by a factor of 10 for analysis. Smaller samples were easily introduced into the TILDAS system by quantitatively freezing the CO₂ gas into a cold finger in the mixing volume.) Calcite was loaded into a glass reaction vessel with a central glass divider; 1 mL of 100% phosphoric acid was loaded in the glass reaction vessel on the opposite side of the divider from the calcite. The vessel was evacuated and placed in a water bath held at a constant temperature of 25°C, and then phosphoric acid was introduced into the calcite section of the reaction vessel. The reaction vessel remained in the water bath at a constant temperature of 25°C for 16 h. The resulting gas was purified using a cryogenic trap to remove water and any noncondensable gases before the CO₂ was cryogenically transferred to a separate gas sampling tube for transfer to the TILDAS analyzer.

2.3 | Fluorination

To determine the actual $\delta^{17}\text{O}$ value of our reference gases, CO₂ was fluorinated to produce O₂ to be measured for triple oxygen isotopes using the conventional nickel bomb fluorination method by Sharma and Clayton,²⁴ modified by Wostbrock et al.¹⁰; 1 mL of CO₂ ($\sim 45 \mu\text{mol CO}_2$) was injected into the fluorination line through a septum and cryogenically transferred to a high-purity nickel reaction vessel; 30 times stoichiometric excess of bromine pentafluoride (BrF₅) was cryogenically transferred into the nickel reaction vessel with the CO₂. The nickel reaction vessel was sealed with a valve and heated to 700°C for 5 days to ensure quantitative conversion of CO₂ to O₂ by the reaction $\text{CO}_2 + 4/5\text{BrF}_5 = \text{O}_2 + \text{CF}_4 + 2/5\text{Br}_2$.

After the fluorination reaction, the reaction vessels were cooled with liquid nitrogen. The reaction by-products CF₄, Br₂, and unreacted BrF₅ remained frozen in the vessel, and the O₂ released from fluorination was purified by passing through two liquid nitrogen traps and then a 100°C NaCl trap to remove any F₂ by converting it to NaF and Cl₂ gas, which were then trapped in a third liquid nitrogen-cooled trap. The O₂ gas produced through fluorination was absorbed on a 5 Å molecular zeolite sieve cooled with liquid nitrogen. The molecular sieve containing the O₂ was then isolated from the fluorination line, and the O₂ was released into a stream of ultra-high-purity helium carrier gas and passed through a 5 Å molecular sieve gas chromatograph at a flow rate of 5 mL/min to remove any trace contamination of NF₃ and N₂. The O₂ in the helium carrier gas was then collected on a second liquid nitrogen-cooled molecular sieve attached to the inlet port of a MAT 253⁺ isotope ratio mass spectrometer (Thermo Fisher, Bremen, Germany) configured for triple oxygen isotope analyses. Helium was pumped away through the inlet pump on the mass spectrometer, and the molecular sieve was heated to release the absorbed O₂ into the sample bellows. The resultant O₂ was analyzed in dual-inlet mode relative to a reference gas calibrated to VSMOW (Vienna Standard Mean Ocean Water), providing a precision of better than $\pm 0.005\%$ (5 per meg) for $\Delta^{17}\text{O}$.¹⁰

Five CO₂ samples were analyzed in this study. They included three IAEA (International Atomic Energy Agency) calcite standards (NBS-18, NBS-19, and IAEA-603; see <https://nucleus.iaea.org/sites/ReferenceMaterials/Pages/Stable-Isotopes.aspx> and https://www-s.nist.gov/srmors/view_detail.cfm?srm=8544 for details) and two internal CO₂ standards (CSI-8628 and CSI-040711). CSI-8628 is a commercial CO₂ tank ($\delta^{18}\text{O} = 29.97\%$), and CSI-040711 is a very light sample produced by equilibrating CO₂ gas with water from an Antarctic ice core ($\delta^{18}\text{O} = -9.28\%$). The $\delta^{13}\text{C}$ and $\delta^{18}\text{O}$ values of CSI-8628 and CSI-040711 were measured on CO₂ gas (before fluorination) using a Thermo-Fisher 253⁺ dual-inlet isotope ratio mass spectrometer with a reference gas calibrated to IAEA standards NBS-18, NBS-19, and IAEA-603. All data are presented in Table 1.

TABLE 1 Triple oxygen isotope data for CO₂ standards

Sample	Analysis	Mole fraction CO ₂ (ppm)	δ ¹⁷ O	δ ¹⁸ O	δ ¹⁷ O	δ ¹⁸ O	Δ ¹⁷ O	δ ¹⁷ O _{corr} ^a	δ ¹⁸ O _{corr} ^a	δ ¹⁷ O _{corr} ^a	δ ¹⁸ O _{corr} ^a
CSI-8628 1	Fluorination	-	15.119	29.077	15.006	28.662	-128	15.584	29.970	15.464	29.530
CSI-8628 2	Fluorination	-	15.367	29.528	15.250	29.100	-115	15.597	29.970	15.477	29.530
CSI-8628 3	Fluorination	-	15.366	29.537	15.249	29.109	-121	15.591	29.970	15.471	29.530
Average		-	15.284	29.381	15.168	28.957	-121	15.591	-	15.470	-
±1σ		-	0.143	0.263	0.141	0.256	7	0.005	-	0.005	-
CSI-8628 1	TILDAS	451.620	15.618	30.017	15.497	29.575	-119	15.593	29.970	15.473	29.530
CSI-8628 2	TILDAS	455.650	15.621	29.996	15.500	29.555	-105	15.607	29.970	15.487	29.530
CSI-8628 3	TILDAS	456.900	15.556	29.876	15.436	29.438	-107	15.605	29.970	15.485	29.530
CSI-8628 4	TILDAS	458.760	15.594	29.963	15.474	29.523	-114	15.598	29.970	15.477	29.530
Average		455.733	15.597	29.963	15.477	29.523	-111	15.601	-	15.480	-
±1σ		3.025	0.030	0.062	0.029	0.060	6	0.006	-	0.006	-
CSI-040711 1	Fluorination	-	-4.189	-7.582	-4.198	-7.611	-179	-5.089	-9.280	-5.102	-9.323
CSI-040711 2	Fluorination	-	-4.244	-7.689	-4.253	-7.719	-178	-5.088	-9.280	-5.101	-9.323
CSI-040711 3	Fluorination	-	-4.877	-8.901	-4.889	-8.941	-168	-5.078	-9.280	-5.091	-9.323
Average		-	-4.437	-8.057	-4.447	-8.090	-175	-5.085	-	-5.098	-
±1σ		-	0.382	0.733	0.384	0.739	6	0.005	-	0.005	-
CSI-040711 1	TILDAS	462.420	-4.763	-8.783	-4.774	-8.822	-116	-5.026	-9.280	-5.039	-9.323
CSI-040711 2	TILDAS	460.600	-4.786	-8.844	-4.798	-8.884	-107	-5.017	-9.280	-5.030	-9.323
CSI-040711 3	TILDAS	457.650	-4.872	-9.013	-4.884	-9.054	-103	-5.013	-9.280	-5.026	-9.323
CSI-040711 4	TILDAS	458.490	-4.940	-9.091	-4.952	-9.132	-130	-5.040	-9.280	-5.053	-9.323
CSI-040711 5	TILDAS	452.470	-4.817	-8.907	-4.829	-8.947	-105	-5.015	-9.280	-5.028	-9.323
Average		458.326	-4.836	-8.928	-4.847	-8.968	-112	-5.022	-	-5.035	-
±1σ		3.765	0.071	0.125	0.071	0.126	11	0.010	-	0.010	-
IAEA-603 ^b	Fluorination	-	20.262	39.012	20.262	39.012	-147	20.262	39.012	20.052	38.270
IAEA-603 1	TILDAS	461.79	20.3869	39.2682	20.1819	38.5168	-155	20.254	39.012	20.052	38.270
IAEA-603 2	TILDAS	456.22	20.4034	39.2684	20.1980	38.5170	-139	20.270	39.012	20.068	38.270
IAEA-603 3	TILDAS	458.58	20.3903	39.2794	20.1852	38.5276	-157	20.252	39.012	20.049	38.270
IAEA-603 4	TILDAS	454.66	20.3571	39.192	20.1527	38.4435	-145	20.264	39.012	20.061	38.270
Average		457.813	20.384	39.252	20.179	38.501	-149	20.260	-	20.057	-
±1σ		3.103	0.020	0.040	0.019	0.039	9	0.008	-	0.007	-

(Continues)

TABLE 1 (Continued)

Sample	Analysis	Mole fraction CO ₂ (ppm)	$\delta^{17}\text{O}$	$\delta^{18}\text{O}$	$\delta^{17}\text{O}$	$\delta^{18}\text{O}$	$\Delta^{17}\text{O}$	$\delta^{17}\text{O}_{\text{corr}}^a$	$\delta^{18}\text{O}_{\text{corr}}^a$	$\delta^{17}\text{O}_{\text{corr}}^a$	$\delta^{18}\text{O}_{\text{corr}}^a$
NBS-18 ^b	Fluorination		9.114	17.524	9.233	17.649	-100	9.072	17.524	9.087	17.372
NBS-18 1	TILDAS	467.130	9.276	17.806	9.220	17.619	-86	9.128	17.524	9.089	17.372
NBS-18 2	TILDAS	461.160	9.262	17.776	9.208	17.580	-83	9.131	17.524	9.098	17.372
NBS-18 3	TILDAS	464.940	9.250	17.735	9.269	17.705	-74	9.140	17.524	9.093	17.372
NBS-18 4	TILDAS	460.580	9.312	17.863	9.232	17.638	-79	9.135	17.524	9.092	17.372
Average		463.453	9.275	17.795	9.232	17.638	-81	9.133	-	9.092	-
$\pm 1\sigma$		3.122	0.027	0.054	0.026	0.053	5	0.004	-	0.004	-
NBS-19-1 ^b	Fluorination		20.348	39.194	20.364	38.858	-155	20.348	39.194	20.146	38.445
NBS-19 1	TILDAS	435.890	20.573	39.623	20.316	38.799	-153	20.350	39.194	20.129	38.445
NBS-19 2	TILDAS	440.310	20.524	39.561	20.324	38.768	-170	20.333	39.194	20.154	38.445
NBS-19 3	TILDAS	451.920	20.532	39.529	20.312	38.780	-145	20.358	39.194	20.135	38.445
NBS-19 4	TILDAS	451.220	20.520	39.542	20.329	38.806	-164	20.339	39.194	20.138	38.445
NBS-19 5	TILDAS	453.390	20.537	39.569	20.329	38.806	-161	20.342	39.194	20.141	38.445
Average		446.546	20.537	39.565	20.329	38.802	-159	20.345	-	20.141	-
$\pm 1\sigma$		7.906	0.021	0.036	0.021	0.035	10	0.009	-	0.009	-

Notes: Results are provided for TILDAS and fluorination for CO₂ sample gas, and CO₂ extracted from carbonate standards using phosphoric acid digestion at 25°C. δ -values are reported in percentage relative to VSMOW, and $\Delta^{17}\text{O}$ is reported in per meg relative to VSMOW. TILDAS data are presented without any further correction using Equation (3). All values are relative to VSMOW.

Abbreviations: TILDAS, tunable infrared laser direct absorption spectroscopy; VSMOW, Vienna Standard Mean Ocean Water.

^aCorrected using the calibrated $\delta^{18}\text{O}$ value of the sample gas by phosphoric acid digestion and analysis of CO₂ by conventional mass spectrometry and the $\Delta^{17}\text{O}$ value from fluorination (see Section 3.1).

^bData from Westbrock et al.¹⁰

2.4 | TILDAS sample inlet system

A schematic of the sample system design is shown in Figure 3. The inlet system is represented by two primary components, the mixing volume (outlines in blue), the TILDAS (outlined in red), and the accompanying valves that are controlled through TDL Wintel (outlined in orange). The entire system was pumped by an oil-free scroll pump (Agilent IDP-15 Dry Scroll Pump, Santa Clara, CA, USA) to prevent any backflow of oil vapors into the vacuum line. The purpose of the mixing volume was to produce a CO₂ sample gas diluted in CO₂-free dry air to obtain a reproducible mixing ratio that matches that of the reference gas. The reference gas used in this study was prepared by filling an evacuated high-pressure gas tank with CO₂ and then dry CO₂-free air to achieve a mixing ratio of 456 ppm CO₂.

For analysis in the TILDAS system, CO₂ produced by phosphoric acid digestion from calcite standards NBS18, NBS19, and IAEA-603 and collected in glass sample tubes was connected to the sample inlet port using a glass vacuum seal. For standards CSI-8628 and CSI-040711, 0.07 mL of CO₂ was introduced into the line using a syringe and injected through a septum on the inlet port. The CO₂ was transferred into the mixing volume by freezing on a cold finger cooled with liquid nitrogen. The liquid nitrogen was removed, and the CO₂ was heated to room temperature and expanded into the mixing volume. Motor-controlled bellows 1 (salvaged from an old VG Prism II mass spectrometer) adjusted the bellows volume until a preset pressure for CO₂ was attained on pressure sensor 1 (Kurt J. Lesker 300 series convection vacuum gauge, Jefferson Hills, PA, USA). Zero air was then added to the mixing volume until the pressure on gauge 2 (Baratron 122AA-01000AD) reached the set pressure (~1 bar) that

produced a mixture of 456 ppm CO₂. (The convection vacuum gauge has a higher precision in the milliTorr to Torr range, whereas the Baratron has a higher precision in the range of 500–1000 Torr.) CO₂ and zero air were mixed for 20 min by alternately opening and closing bellows 1 and 2. Incomplete mixing was observed when mixing time was less than 10 min, as evidenced by a drift in the mixing ratio of the sample gas measured in the TILDAS between sample injections.

The TILDAS portion of the sampling system (Figure 3) includes the instrument and the automated valve process controlled through TDL Wintel and the IRIS interface developed by ARI. The operation procedure is outlined here. The optical cell and the sample aliquot volume were evacuated and flushed with nitrogen. The absorption cell was filled to 30 Torr with dry nitrogen, and a 15 s background measurement was recorded for subtraction from future measured spectra. The absorption cell was then evacuated, and the working reference was introduced through a 0.004 inch critical orifice (O'Keefe IC-PC4-4-SS precision metal orifice, Monroe, CT, USA) using an electronic valve automated to hit a target pressure of 38 Torr. Once the reference gas (or sample gas) was introduced into the absorption cell, the system was allowed to stabilize for 18 s, and then data were collected for 12 s. While the reference gas was being measured, an aliquot of the sample gas was prepared. The mixing volume pressure was adjusted by closing bellows 2 to hit a target pressure on pressure gauge 2 that would correspond to the same working pressure as the reference gas when expanded into the optical cell (38 Torr). Once the reference gas measurement was completed, the absorption cell was evacuated and then flushed with nitrogen and evacuated a second time. The sample aliquot was then expanded into the optical cell. After the sample measurement, the absorption cell

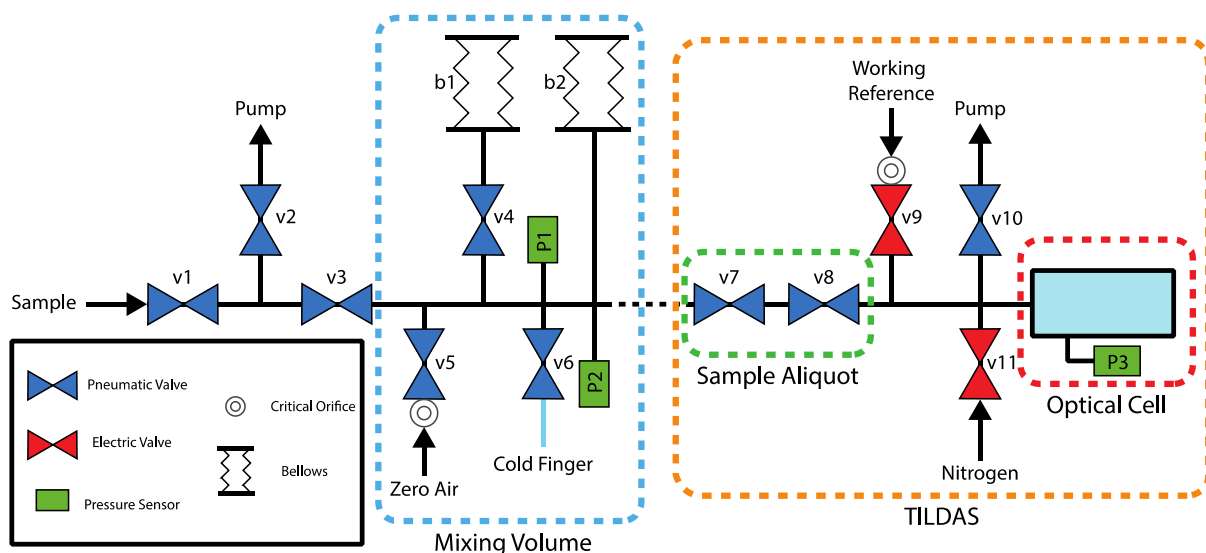

FIGURE 3 Schematic diagram of the sample gas inlet system for the TILDAS (tunable infrared laser direct absorption spectroscopy) spectrometer. The system consists of a mixing volume for sample preparation (blue box), a small volume between two pneumatic valves (Swagelok bellows valves) to acquire aliquots of sample gas from the mixing volume (green box), the automated valves actuated on a schedule by IRIS (orange box), and the absorption cell in the TILDAS instrument (red box) [Color figure can be viewed at wileyonlinelibrary.com]

was evacuated and flushed with nitrogen, and the process was repeated for 12 cycles. After the introduction of each sample gas, its pressure in the manifold was adjusted to the correct pressure by compressing the bellows. The isotope values of each sample measurement were determined relative to the reference gas by interpolating the prior and subsequent reference gas measurements in time. The total time required for 12 reference-sample cycles was 30 min.

3 | RESULTS AND DISCUSSION

3.1 | Fluorination

The $\Delta^{17}\text{O}$ values of CSI-8628 and CSI-040711 determined by fluorination are presented in Table 1. Both CSI-8628 and CSI-040711 were fluorinated thrice with an average $\Delta^{17}\text{O}$ of -121 and -111 per meg with standard deviations of ± 7 and ± 6 per meg, respectively. The $\delta^{17}\text{O}$ and $\delta^{18}\text{O}$ values from fluorination are generally slightly less than the correct value (due to incomplete fluorination of the CO_2 gas), but it has been shown that $\delta^{17}\text{O}$ and $\delta^{18}\text{O}$ covary with a λ value of 0.528, such that the $\Delta^{17}\text{O}$ value is constant and independent of the measured $\delta^{18}\text{O}$ value (see Wostbrock et al.¹⁰ for further details). Using the $\Delta^{17}\text{O}$ obtained using fluorination and the $\delta^{18}\text{O}$ measured from the CO_2 gas, we can back-calculate to determine the $\delta^{17}\text{O}$ value of our CO_2 standard gases. The fluorinated triple oxygen isotope values for IAEA-603, NBS-18, and NBS-19 of CO_2 produced by phosphoric acid digestion at 25°C referenced in this study are from Wostbrock et al.¹⁰ (Table 1), which was measured on the same extraction line.

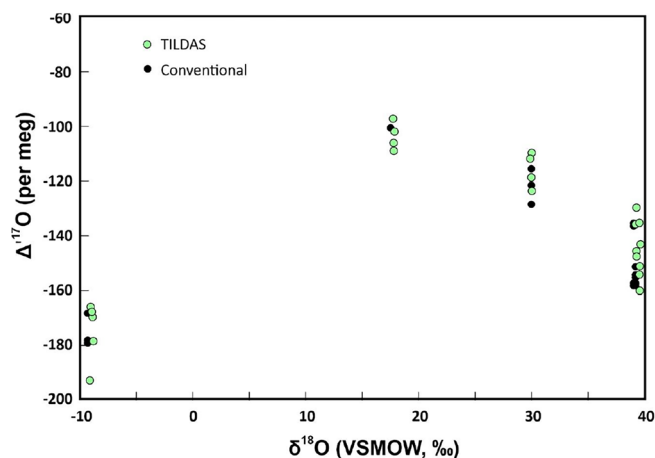

FIGURE 4 Results of TILDAS (tunable infrared laser direct absorption spectroscopy) $\delta^{18}\text{O}$ and $\Delta^{17}\text{O}$ measurements of CO_2 compared to those obtained using dual-inlet mass spectrometry. For dual inlet, the $\Delta^{17}\text{O}$ value was measured using conventional fluorination on O_2 , and the $\delta^{18}\text{O}$ value was measured using conventional phosphoric acid digestion and analysis of CO_2 gas. The $\Delta^{17}\text{O}$ values of the TILDAS data were corrected following Equation (4) [Color figure can be viewed at wileyonlinelibrary.com]

3.2 | TILDAS results

3.2.1 | Precision

The five standard gases calibrated using the VSMOW-SLAP (Standard Light Antarctic Precipitation) scale (CSI-8628, CSI-040711, IAEA-603, NBS-18, and NBS-19) were analyzed using TILDAS and inlet system described earlier. Each sample was analyzed four or five times, with an analysis consisting of 12 sample-reference cycles and a data filter threshold of 2σ . Comparison of the $\delta^{18}\text{O}$ - $\Delta^{17}\text{O}$ values obtained using TILDAS and conventional methods (phosphoric acid digestion for $\delta^{18}\text{O}$ and fluorination for $\Delta^{17}\text{O}$) is shown in Figure 4. The averaged $\delta^{18}\text{O}$ values reported using TILDAS agree with values calibrated by measuring CO_2 gas on the IRMS (Table 1) to within $\pm 0.03\text{‰}$ for all standards, except for CSI-040711, where the averaged $\delta^{18}\text{O}$ for all runs differs from the IRMS measurement by $\pm 0.35\text{‰}$. The standard deviations of the $\delta^{17}\text{O}$ and $\delta^{18}\text{O}$ values for CSI-040711 were $\pm 0.07\text{‰}$ and $\pm 0.12\text{‰}$ (standard error, 2σ), respectively. All other references analyzed using TILDAS had a standard deviation of $\leq 0.03\text{‰}$ for $\delta^{17}\text{O}$ and $\leq 0.06\text{‰}$ for $\delta^{18}\text{O}$. Despite the variation in the $\delta^{17}\text{O}$ and $\delta^{18}\text{O}$ values for CSI-040711, $\delta^{17}\text{O}$ and $\delta^{18}\text{O}$ covary (Figure 5), and the standard deviation for $\Delta^{17}\text{O}$ is 11 per meg over five analyses. The overall standard deviation of all analyses performed is ± 8 per meg for $\Delta^{17}\text{O}$.

3.2.2 | Testing analytical conditions for precision and accuracy

There are a number of variables that could affect the precision of the TILDAS system. These include the following: (a) fractionation during introduction of sample gas, (b) differences in the working pressure of the reference and sample gases, (c) differences in the CO_2 mole

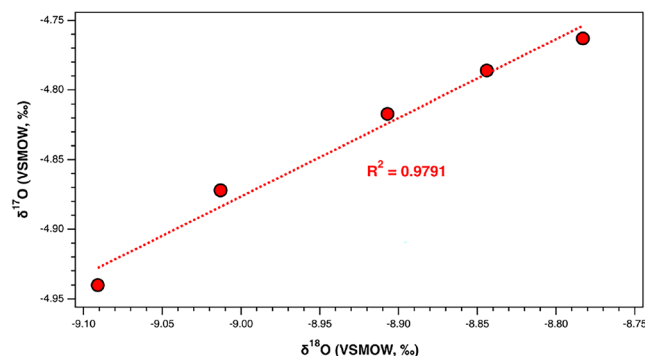

FIGURE 5 Covariance in $\delta^{17}\text{O}$ and $\delta^{18}\text{O}$ of CSI-040711. There is significant variation in the $\delta^{17}\text{O}$ and $\delta^{18}\text{O}$ values for subsequent analyses of CSI-040711, with a standard deviation of 0.07‰ and 0.12‰ , respectively. $\delta^{17}\text{O}$ and $\delta^{18}\text{O}$ covary, and the standard deviation for $\Delta^{17}\text{O}$ is 11 per meg for five analyses, giving us confidence in the $\Delta^{17}\text{O}$ values. Fluorination values are $\delta^{18}\text{O} = -9.28\text{‰}$ and $\delta^{17}\text{O} = -5.035\text{‰}$ [Color figure can be viewed at wileyonlinelibrary.com]

fraction of the reference and sample gases, and (d) extreme differences in the $\delta^{18}\text{O}$ values of reference and sample. We tested the sensitivity of the system to these parameters by intentionally measuring samples where the sample and reference values were different.

3.2.3 | Potential fractionation during introduction of sample gas

Potential fractionation associated with the inlet system and gas introduction process was assessed by filling the mixing volume with the working reference gas to act as the “sample gas” and running it against itself (a so-called zero enrichment measurement). The average $\delta^{17}\text{O}$ and $\delta^{18}\text{O}$ values of four zero enrichment analyses differ from the calibrated working reference value by $\pm 0.005\text{‰}$ for $\delta^{17}\text{O}$ and $\pm 0.007\text{‰}$ for $\delta^{18}\text{O}$ with standard deviations similar to those reported for the sample gases analyzed in this study ($\leq 0.024\text{‰}$ for $\delta^{17}\text{O}$ and $\leq 0.036\text{‰}$ for $\delta^{18}\text{O}$), excluding CSI-040711 (Table 2). The $\Delta^{17}\text{O}$ values have a precision of 9 per meg (standard error, 2σ). With the results of the zero enrichment and the four other standards analyzed having reproducible results, it does not appear that there is fractionation associated with the sampling system and analysis procedure.

3.2.4 | Total working pressure

The infrared-absorption lines follow well-established shapes whose mathematical fit is determined using a Voigt line shape profile. A limited range of working pressures for a given spectral region provides well-defined peaks with sufficient absorption for all isotopologues within the spectral region. Very low working pressure results in insufficient signal and poorly defined absorption lines, whereas very high working pressure results in broadening the absorption peaks and interference between isotopologue spectral lines.

TABLE 2 Sampling system zero enrichments

Sample	$\delta^{17}\text{O}$	$\delta^{18}\text{O}$	$\delta^{17}\text{O}$	$\delta^{18}\text{O}$	$\Delta^{17}\text{O}$
Zero 1	17.407	32.724	17.257	32.200	256
Zero 2	17.450	32.782	17.299	32.256	268
Zero 3	17.476	32.818	17.325	32.291	276
Zero 4	17.418	32.722	17.268	32.198	267
Zero 5	17.435	32.771	17.284	32.245	259
Zero 6	17.429	32.772	17.279	32.246	253
Average	17.436	32.765	17.285	32.239	263
$\pm 1\sigma$	0.025	0.037	0.024	0.035	9
Assumed working reference Value	17.445	32.779	17.295	32.253	265

Notes: Results for zero enrichment analysis, where working reference gas was loaded in the mixing volume of the inlet system and analyzed as “sample” to test potential fractionation associated with sample introduction.

To validate a range of acceptable working pressures, we conducted zero enrichment analyses at working pressures of 30, 34, and 38 Torr for both the sample and reference gases. Working reference gas was analyzed against itself for the three different working pressures. The results for the zero enrichments at 30, 34, and 38 Torr are shown in Figure 6. The results for each working pressure are within the error of the $\Delta^{17}\text{O}$ value of the working reference and a standard deviation of $< \pm 2$ per meg for the three analyses.

The consistency of results over a range of working pressures allows us to be flexible with sample size. All analyses were performed at 38 Torr, where an excess of the sample was reacted to allow for multiple analyses of the same gas. Reducing the working pressure from 38 to 30 Torr reduces the sample size required by approximately one-third.

3.2.5 | Working pressure mismatch

To determine the acceptable discrepancy between the sample and reference pressure, a series of zero enrichments were performed at mismatched pressures. The working pressure for the “sample gas” was adjusted for each subsequent aliquot over 12 measurement cycles, whereas the working reference pressure was held constant at 38 Torr. There is a strong linear relationship ($R^2 = 0.935$) between the difference in the measured $\Delta^{17}\text{O}$ from the accepted working reference value and the difference between the working pressure of the “sample” and the working reference (Figure 7).

The working pressure for the sample and reference gas during a measurement cycle must be within ± 23 mTorr to achieve a precision of ± 10 per meg (Figure 7). Using the bellows system in our sampling system, we can introduce the sample gas at a working pressure with high reproducibility (± 10 mTorr). Generally, the range in working pressure for both sample and reference over 12 measurement cycles is less than 40 mTorr.

There are instances in which there are anomalous spikes or drops in the working reference pressure. These deviations in pressure result from fluctuations in the backing pressure of the working reference

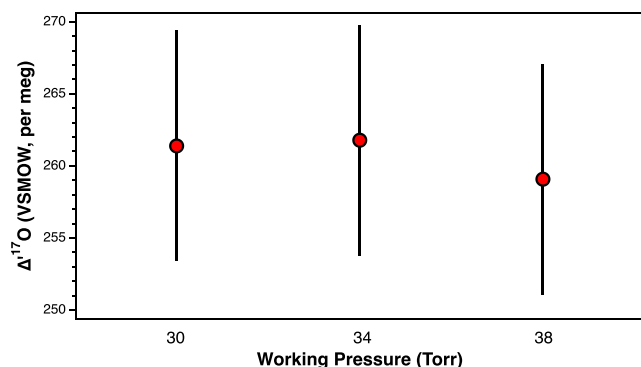

FIGURE 6 Effect of varying the working pressures in the sample cell. Results of zero enrichment analysis at working pressures of 30, 34, and 38 Torr. All analyses are within error of the accepted value of the working reference gas, $\Delta^{17}\text{O} = 265$ per meg. Error bars are $\pm 1\sigma$ (8 per meg) [Color figure can be viewed at wileyonlinelibrary.com]

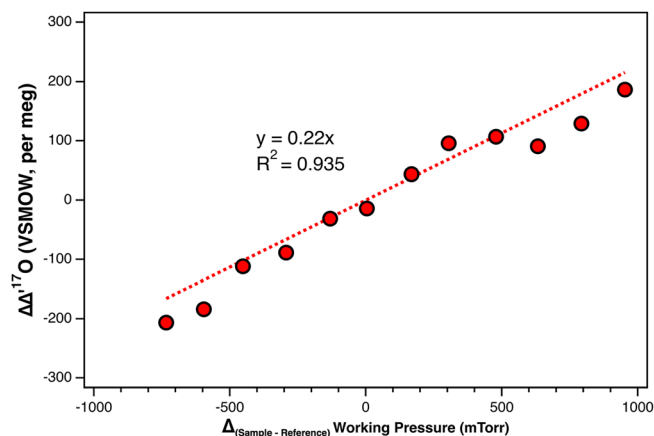

FIGURE 7 Sample versus working reference pressure effect. Graphical results for zero enrichment analysis illustrating the importance of matching the working pressure of the sample and reference gases. Each dot represents one sample-reference measurement (total 12 cycles). The working pressure of the sample was increased for each subsequent cycle, whereas the reference pressure remained constant. The y-axis is the difference between the measured $\Delta^{17}\text{O}$ value and the accepted $\Delta^{17}\text{O}$ value of the working reference. To achieve a precision of 10 per meg for $\Delta^{17}\text{O}$, the working pressure of the sample and reference pressure must match and be constant within ± 20 mTorr, which is easily achieved with our instrument [Color figure can be viewed at wileyonlinelibrary.com]

gas feeding through the critical orifice altering the flow rate, resulting in the valve being closed too early or late to hit the target pressure. Instances of spikes or drops in the working reference pressure are uncommon and, at most, occur for one reference measurement over a 12-cycle sample measurement. The difference between the reference pressure and the target pressure introduces an isotopic shift such that the data points calculated using the anomalous reference measurement are excluded from data analysis.

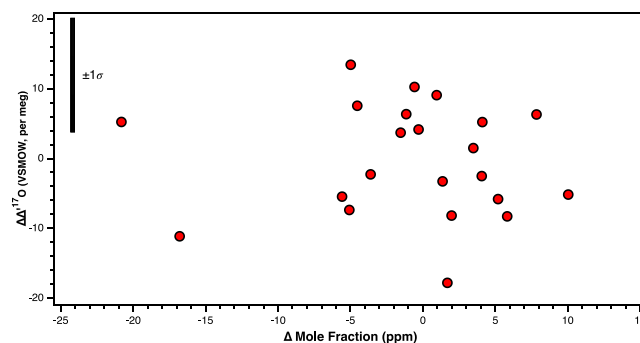

FIGURE 8 Sample versus working reference mole fraction. Dependence of $\Delta^{17}\text{O}$ based on the CO_2 mole fraction of the sample and working reference matching. The y-axis is the difference between the measured $\Delta^{17}\text{O}$ value of the analysis and the averaged $\Delta^{17}\text{O}$ for the standard from Table 1. The x-axis is the difference between the mole fraction of CO_2 in the sample gas (Table 1) and the mole fraction of CO_2 in the reference gas (456 ppm). Our sampling system reproducibly produces a sample gas within $\pm 2\%$ of the target CO_2 mole fraction, and differences in the CO_2 mole fraction of $\pm 2\%$ do not measurably affect the $\Delta^{17}\text{O}$ value [Color figure can be viewed at wileyonlinelibrary.com]

3.2.6 | Mole fraction

The TILDAS instrument must be operated with a near-ambient dilution of CO_2 in zero air (or dry N_2). The precise dilution is not important as long as it is constant: the reference and sample gases must use the same dilution to avoid an artifactual dependence of the measured isotope ratios on the sample gas CO_2 mole fraction. Such dependence arises not from the spectrometer per se but rather from the use of only a single reference gas for calibration. In general, TILDAS measurement error is partly multiplicative (i.e., gain error) and partly additive (i.e., zero-offset error), and a single reference gas can be used only to correct for one kind of error or the other. The super ratio used here to express a sample gas isotope ratio relative to the reference gas effectively assumes that all measurement error is multiplicative. The goal is therefore to minimize the impact of additive error by subtracting spectral background measurements (as mentioned earlier) and by keeping the sample and reference mole fractions as close as possible. When the sample and reference gas mole fractions are the same, the additive errors cancel out. Conversely, as the sample and reference gas mole fractions diverge, the additive errors cause increasing bias.

A major challenge in designing the sample system was the ability to mix a sample gas of CO_2 and dry air efficiently and reproducibly within several ppm CO_2 of the reference gas. The target mole fraction is ~ 450 ppm CO_2 in zero air (456 ppm in our system). To examine the effects of differences in the mole fraction between the sample and working reference gases, the mixing ratio of the sample gas was varied slightly above and below the target mole fraction. A mismatch of 20 ppm between the mixing ratio of reference and sample gases was found to have no apparent effect (Figure 8).

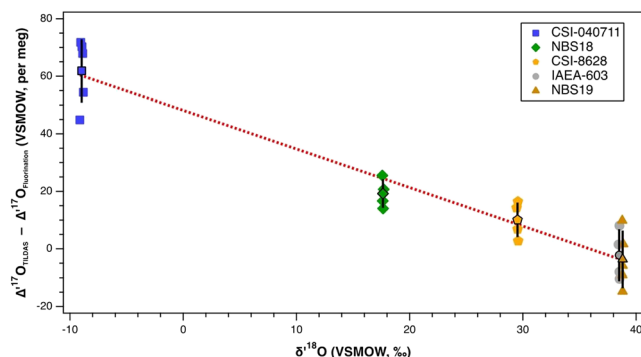

FIGURE 9 Effect of $\delta^{18}\text{O}$ on the $\delta^{18}\text{O}$ value of the sample relative to working gas; offset in the $\Delta^{17}\text{O}$ value reported from the TILDAS (tunable infrared laser direct absorption spectroscopy) and the accepted value from fluorination. The y-axis is the difference between the $\Delta^{17}\text{O}$ value from the TILDAS reference gas for each analysis and the accepted $\Delta^{17}\text{O}$ value from fluorination (Table 1). The lighter the $\delta^{18}\text{O}$ value of a sample (the more different from the reference gas value of 32.77‰), the greater the $\Delta^{17}\text{O}$ shifts from the actual value. The linear relationship between the measured $\delta^{18}\text{O}$ value and the shift in $\Delta^{17}\text{O}$ can be corrected using Equation (4) based on the linear best fit (red dashed curve) [Color figure can be viewed at wileyonlinelibrary.com]

3.2.7 | Effect of different isotope values for sample and reference

To test the “linearity” of the system related to extreme differences in the $\delta^{18}\text{O}$ values of the sample and reference on the measured $\Delta^{17}\text{O}$ value, the samples were specifically prepared to cover a wide $\delta^{18}\text{O}$ range of 48‰. Figure 9 shows the offset in the $\Delta^{17}\text{O}$ values measured in the TILDAS unit versus those obtained by fluorination as a function of the $\delta^{18}\text{O}$ value. There is a systematic difference between the $\Delta^{17}\text{O}$ values measured by both systems that vary linearly as a function of the difference between the $\delta^{18}\text{O}$ value of the sample and reference. The larger the difference between the two $\delta^{18}\text{O}$ values, the greater the $\Delta^{17}\text{O}$ value shifts from the true value. Over a range in $\delta^{18}\text{O}$ values from -9‰ to $+38\text{‰}$, $\Delta^{17}\text{O}$ shifts by ~ 65 per meg. The linear relationship between the measured $\delta^{18}\text{O}$ (per mil) and the offset in the $\Delta^{17}\text{O}$ (per meg) from the true value allows for using the equation (applicable to our instrument):

$$\Delta^{17}\text{O}_{\text{corrected}} = \Delta^{17}\text{O}_{\text{measured}} + 1.4513 \times (\delta^{18}\text{O}_{\text{measured}} - \delta^{18}\text{O}_{\text{reference gas}}) \quad (4)$$

The $\delta^{17}\text{O}$ value of the sample gas can then be back-calculated using the measured $\delta^{18}\text{O}$ and the corrected $\Delta^{17}\text{O}$ values. Over a period of 6 months, we have not observed any significant changes to this correction formula.

The shift in $\Delta^{17}\text{O}$ over a large range of $\delta^{18}\text{O}$ values is potentially a result of cross-correlation in the spectral fit between the isotopologues in the spectrum. Theoretically, the dependence in the

spectral fit between the isotopologues could be reduced or removed with improvements in the spectral fit and if the spectral lines for the isotopologues in the spectrum were completely independent from one another. But, due to subtle baseline curvature effects in the spectrum and spectral overlap between the isotopologues in the spectrum (Figure 1), the dependence in the spectral fit between the isotopologues cannot be determined, and calibration and correction of the $\Delta^{17}\text{O}$ values are necessary.

Additional considerations for the future involve the possibility of trace organic compounds in the CO_2 sample gas due to phosphoric acid digestion of organic-rich carbonates.²⁵ The effect of this possible contaminant has not yet been evaluated.

4 | CONCLUSION

We have demonstrated that the TILDAS (ARI) can measure the triple oxygen isotope composition of CO_2 with a precision of ± 10 per meg for $\Delta^{17}\text{O}$ and $\pm 0.03\text{‰}$ for $\delta^{18}\text{O}$ values. The system is accurate as long as the sample and reference gases have similar mixing ratios and $\delta^{18}\text{O}$ values. The effect of different $\delta^{18}\text{O}$ values between reference and sample is linear and small (~ 1 per meg $\Delta^{17}\text{O}$ per 1 per mil $\delta^{18}\text{O}$) and easily corrected for.

With our sampling system configuration for the TILDAS instrument, sample size is reduced to a tenth of that needed to perform traditional fluorination reactions for triple oxygen isotope analyses. A 70 μL injection of CO_2 needed for a 12-measurement cycle analysis is equivalent to 300 μg of pure carbonate reacted with phosphoric acid. The system can easily be modified to reduce the requirement to 200 μg carbonate equivalent.

The TILDAS instrument's ability to measure triple oxygen isotopes directly from CO_2 using laser spectroscopy removes the need to convert CO_2 to O_2 using methods such as fluorination to remove the isobaric interference at mass 45. Sample size (300 μg), analysis time (~ 30 min), and cost are significantly less using TILDAS, whereas precision for $\Delta^{17}\text{O}$ is ≤ 10 per meg, comparable to fluorination.

Operating parameters such as cell pressure and CO_2 - N_2 mixing ratio must be controlled to a high tolerance. We have developed an inlet system that allows for sample and reference gas cell pressures to be the same within 0.02 Torr and CO_2 mixing ratios within 2% of each other. Differences of $\pm 2\%$ between the sample and working reference CO_2 mixing ratios do not appreciably affect $\Delta^{17}\text{O}$, but further work should be done to test this effect when mixing ratios are larger than this. The system can be fully automated so that a large number of analyses can be made with minimal effort.

ACKNOWLEDGMENTS

This research was supported by National Science Foundation grant number EAR 2025107 to Z.S. and NOAA grant SBIRgrant#WC-133R-15-CN-0086 to DN. The authors thank Colin Carney and Christian Dietz for help with the construction of the bellows system. Catherine Peshek and Melina Vugrin aided in calibration of the system.

PEER REVIEW

The peer review history for this article is available at <https://publons.com/publon/10.1002/rcm.9391>.

DATA AVAILABILITY STATEMENT

The results of the paper are included in the tables. Additional information can be obtained by contacting the corresponding author.

ORCID

Zachary Sharp  <https://orcid.org/0000-0003-1902-5542>

REFERENCES

- Urey H. The thermodynamic properties of isotopic substances. *J Chem Soc (Resumed)*. 1947;562-581. doi:10.1039/jr9470000562
- Urey H, Lowenstam H, Epstein S, McKinney C. Measurement of Paleotemperatures and temperatures of the upper cretaceous of England, Denmark, and the southeastern United States. *GSA Bulletin*. 1951;62(4):399-416. doi:10.1130/0016-7606(1951)62[399:MOPATO]2.0.CO;2
- Eiler J. "Clumped-isotope" geochemistry—The study of naturally-occurring, multiply-substituted isotopologues. *Earth Planet Sci Lett*. 2007;262(3-4):309-327. doi:10.1016/j.epsl.2007.08.020
- Pack A, Herwartz D. The triple oxygen isotope composition of the earth mantle and understanding $\Delta^{17}\text{O}$ variations in terrestrial rocks and minerals. *Earth Planet Sci Lett*. 2014;390:138-145. doi:10.1016/j.epsl.2014.01.017
- Miller M. Isotopic fractionation and the quantification of ^{17}O anomalies in the oxygen three-isotope system: An appraisal and geochemical significance. *Geochim Cosmochim Acta*. 2002;66(11):1881-1889. doi:10.1016/S0016-7037(02)00832-3
- Passey B, Hu H, Ji H, et al. Triple oxygen isotopes in biogenic and sedimentary carbonates. *Geochim Cosmochim Acta*. 2014;141:1-25. doi:10.1016/j.gca.2014.06.006
- Sharp Z, Gibbons J, Maltsev O, et al. A calibration of the triple oxygen isotope fractionation in the $\text{SiO}_2\text{-H}_2\text{O}$ system and applications to natural samples. *Geochim Cosmochim Acta*. 2016;186:105-119. doi:10.1016/j.gca.2016.04.047
- Wostbrock J, Brand U, Coplen T, et al. Calibration of carbonate-water triple oxygen isotope fractionation: Seeing through diagenesis in ancient carbonates. *Geochim Cosmochim Acta*. 2020;288:369-388. doi:10.1016/j.gca.2020.07.045
- McCrea J. On the isotopic chemistry of carbonates and a Paleotemperature scale. *J Chem Phys*. 1950;18(6):849-857. doi:10.1063/1.1747785
- Wostbrock J, Cano E, Sharp Z. An internally consistent triple oxygen isotope calibration of standards for silicates, carbonates and air relative to VSMOW2 and SLAP2. *Chem Geol*. 2020;533:9.
- Brenninkmeijer C, Röckmann T. A rapid method for the preparation of O_2 from CO_2 for mass spectrometric measurement of $^{17}\text{O}/^{16}\text{O}$ ratios. *Rapid Commun Mass Spectrom*. 1998;12(8):479-483. doi:10.1002/(SICI)1097-0231(19980430)12:8<3C479::AID-RCM184%3E3.O.CO;2-R
- Mahata S, Bhattacharya S, Liang M. An improved method of high-precision determination of $\Delta^{17}\text{O}$ of CO_2 by catalyzed exchange with O_2 using hot platinum. *Rapid Commun Mass Spectrom*. 2016;30(1):119-131. doi:10.1002/rcm.7423
- Mahata S, Bhattacharya S, Wang C, Liang M. Oxygen isotope exchange between O_2 and CO_2 over hot platinum: An innovative technique for measuring $\Delta^{17}\text{O}$ in CO_2 . *Anal Chem*. 2013;85(14):6894-6901. doi:10.1021/ac4011777
- Adnew G, Hofmann M, Paul D, et al. Determination of the triple oxygen and carbon isotopic composition of CO_2 from atomic ion fragments formed in the ion source of the 253 ultra high-resolution isotope ratio mass spectrometer. *Rapid Commun Mass Spectrom*. 2019;33(17):1363-1380. doi:10.1002/rcm.8478
- Passey B, Levin N. Triple oxygen isotopes in meteoric waters, carbonates, and biological apatites: Implications for continental paleoclimate reconstruction. *Rev Mineral Geochem*. 2021;86(1):429-462. doi:10.2138/rmg.2021.86.13
- Sakai S, Matsuda S, Hikida T, et al. High-precision simultaneous $^{18}\text{O}/^{16}\text{O}$, $^{13}\text{C}/^{12}\text{C}$, and $^{17}\text{O}/^{16}\text{O}$ analyses for microgram quantities of CaCO_3 by tunable infrared laser absorption spectroscopy. *Anal Chem*. 2017;89(21):11846-11852. doi:10.1021/acs.analchem.7b03582
- Steur P, Scheeren H, Nelson D, McManus J, Meijer H. Simultaneous measurement of $\delta^{13}\text{C}$, $\delta^{18}\text{O}$ and $\delta^{17}\text{O}$ of atmospheric CO_2 —performance assessment of a dual-laser absorption spectrometer. *Atmos Meas Tech*. 2021;14(6):4279-4304. doi:10.5194/amt-14-4279-2021
- HITRAN. High-resolution transmission molecular absorption database. 2014.
- Hollas J. *Modern Spectroscopy*. John Wiley & Sons; 2004.
- Swinehart D. The beer-lambert law. *J Chem Educ*. 1962;39(7):333-335. doi:10.1021/ed039p333
- McManus J, Kebabian P, Zahniser M. Astigmatic mirror multipass absorption cells for long-path-length spectroscopy. *Appl Optics*. 1995;34(18):3336-3348. doi:10.1364/AO.34.003336
- McManus J, Nelson D, Zahniser M. Design and performance of a dual-laser instrument for multiple isotopologues of carbon dioxide and water. *Opt Express*. 2015;23(5):6569-6586. doi:10.1364/OE.23.006569
- Wang Z, Nelson D, Dettman D, et al. Rapid and precise analysis of carbon dioxide clumped isotopic composition by tunable infrared laser differential spectroscopy. *Anal Chem*. 2020;92(2):2034-2042. doi:10.1021/acs.analchem.9b04466
- Sharma T, Clayton R. Measurement of $\text{O}^{18}\text{O}^{16}$ ratios of total oxygen of carbonates. *Geochim Cosmochim Acta*. 1965;29(12):1347-1353. doi:10.1016/0016-7037(65)90011-6
- Brand WA, Geilmann H, Crosson ER, Rella CW. Cavity ring-down spectroscopy versus high-temperature conversion isotope ratio mass spectrometry; a case study on $\delta^2\text{H}$ and $\delta^{18}\text{O}$ of pure water samples and alcohol/water mixtures. *Rapid Commun Mass Spectrom*. 2009;23(12):1879-1884. doi:10.1002/rcm.4083

How to cite this article: Perdue N, Sharp Z, Nelson D, Wehr R, Dyroff C. A rapid high-precision analytical method for triple oxygen isotope analysis of CO_2 gas using tunable infrared laser direct absorption spectroscopy. *Rapid Commun Mass Spectrom*. 2022;36(21):e9391. doi:10.1002/rcm.9391