

Dr. Varanasi

QH104.5  
.C65M34  
1996

**Benthic invertebrates and  
sediment characteristics at  
10 dredged-material disposal  
areas (beach nourishment)  
in the lower Columbia River,  
1994-1995**

**CZES**

**Coastal Zone and  
Estuarine Studies  
Division**

by George T. McCabe, Jr.  
and Susan Hinton

**Northwest Fisheries  
Science Center**

February 1996

**National Marine  
Fisheries Service**

Seattle, Washington

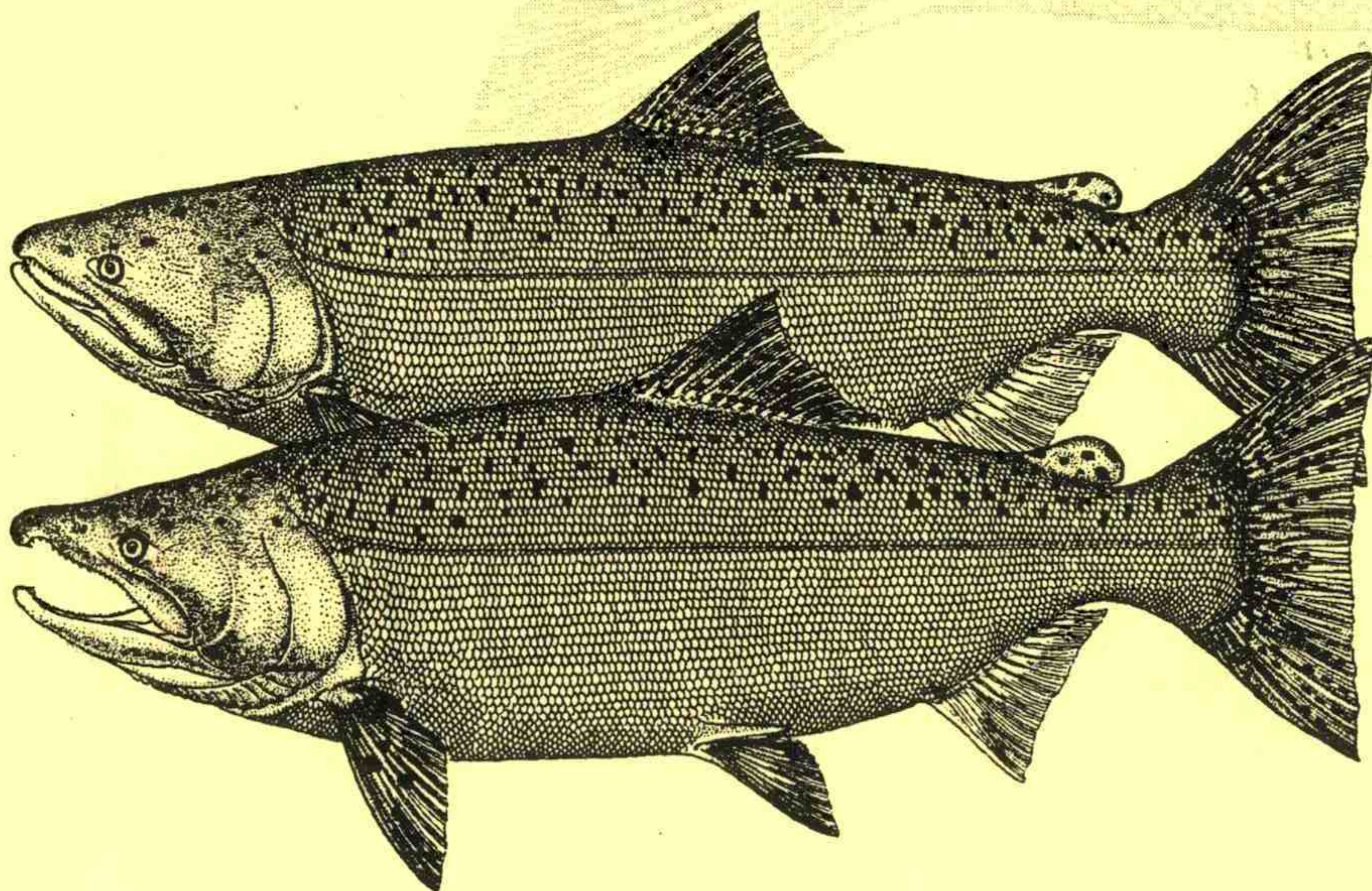

~~NWFS060~~

BENTHIC INVERTEBRATES AND SEDIMENT CHARACTERISTICS AT 10  
DREDGED-MATERIAL DISPOSAL AREAS (BEACH NOURISHMENT) IN THE  
LOWER COLUMBIA RIVER, 1994-1995

QH  
104.5  
C65  
M34  
1996

by  
George T. McCabe, Jr.  
and  
Susan A. Hinton

Funded by

U.S. Army Corps of Engineers  
Portland District  
P.O. Box 2946  
Portland, Oregon 97208  
(Contract E96940050)

and

Coastal Zone and Estuarine Studies Division  
Northwest Fisheries Science Center  
National Marine Fisheries Service  
National Oceanic and Atmospheric Administration  
2725 Montlake Boulevard East  
Seattle, Washington 98112

February 1996

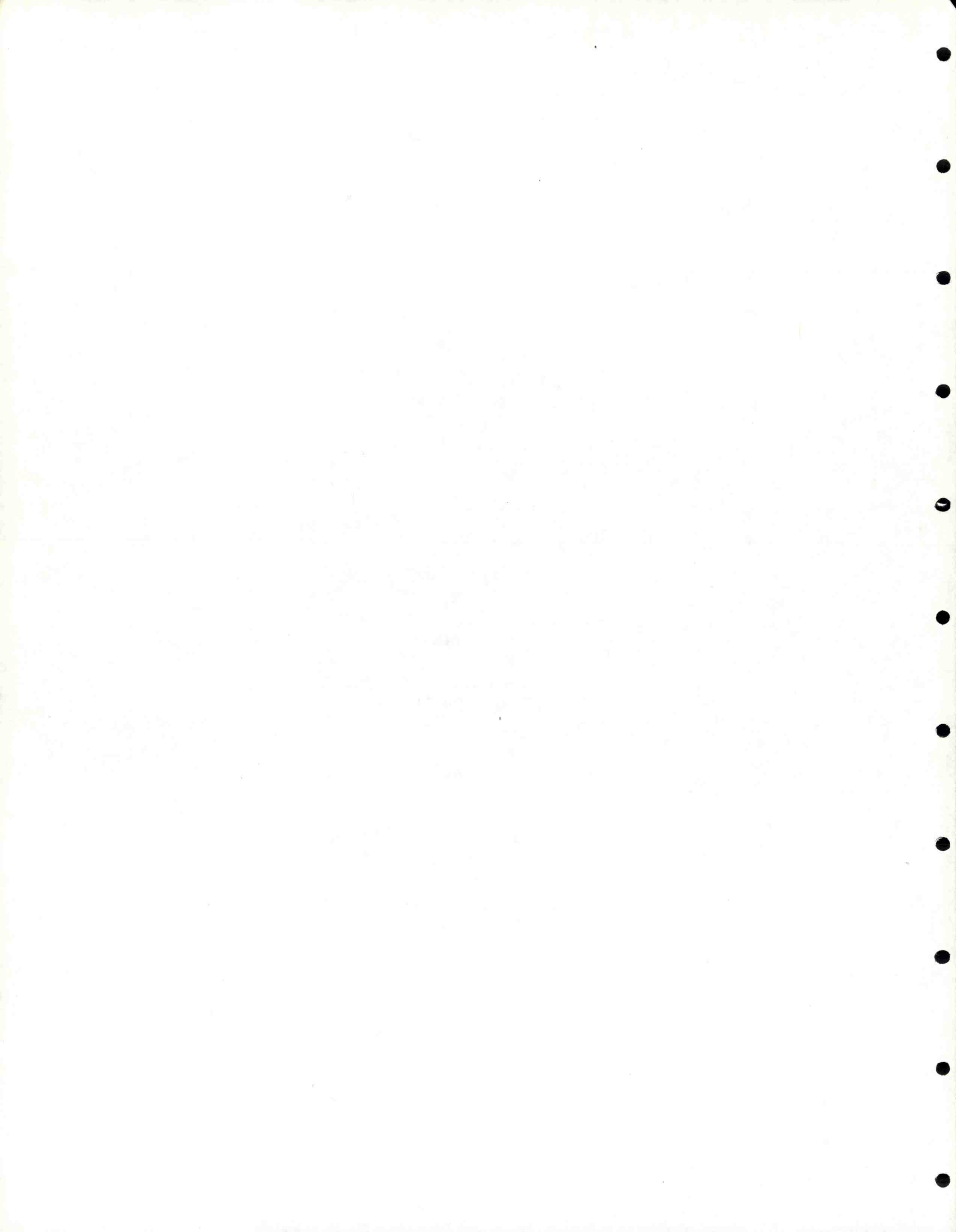

## EXECUTIVE SUMMARY

The disposal of dredged material in a narrow band (about 30 m) onto beaches in the lower Columbia River is commonly referred to as beach nourishment. In 1994, the Portland District of the U.S. Army Corps of Engineers (COE) contracted with the National Marine Fisheries Service (NMFS) to conduct four quarterly surveys at 10 beach nourishment areas in the lower Columbia River. All 10 disposal areas had been used in the past for the disposal of dredged material pumped from the bottom of the navigational channel. However, the COE is currently required to complete biological assessments prior to any future disposal of dredged material in these 10 areas.

The lower Columbia River is presently designated as critical habitat for endangered Snake River Pacific salmon (*Oncorhynchus* spp.). Benthic invertebrates, particularly the amphipod *Corophium salmonis*, found in intertidal and shallow subtidal habitats of the Columbia River estuary are seasonally important in the diet of juvenile salmonids. The overall goal of the study was to describe the benthic invertebrate communities at the beach nourishment areas. Specifically, we assessed benthic invertebrate species composition, standing crops, diversity, and equitability at each of the 10 areas. We also examined the relationship between sediment median grain size and standing crops of *Corophium* spp.

Benthic invertebrate and sediment samples were collected at the 10 beach nourishment areas in July and October 1994 and January and April 1995 with polyvinyl chloride (PVC) coring devices. The 10 areas were designated Beach Nourishment Areas O-34.0, W-40.9, W-43.8, O-44.0, W-45.0, O-45.1, O-47.8, O-57.0, W-70.1, and O-75.8. The "O" and "W"

refer to Oregon and Washington, and the succeeding number refers to the approximate location in river miles from the mouth of the river.

With the exceptions of Beach Nourishment Areas O-47.8 and O-75.8, total densities (i.e., standing crops) of benthic invertebrates in the beach nourishment areas were not significantly different ( $P > 0.05$ ) between the 4 months. Densities of *Corophium* spp., most of which were *C. salmonis*, were not significantly different ( $P > 0.05$ ) between months, except at Area O-75.8. In all areas except Area O-45.1, total benthic invertebrate and *Corophium* spp. densities were significantly higher ( $P < 0.05$ ) at sampling stations 30 m from the high tide mark on the beach than at stations 15 m from the high tide mark. Densities of *Corophium* spp. varied widely within and between areas, with densities at individual stations ranging from 0 to more than 82,000 organisms/m<sup>2</sup>. Mean numbers of taxa/categories (by month) collected in the beach nourishment areas were generally low, ranging from 2 to 8.

Major benthic invertebrate taxa collected in the 10 beach nourishment areas included nemertean, oligochaetes, *Fluminicola virens*, *Corbicula fluminea*, *Corophium salmonis*, *Corophium spinicorne*, Chironomidae larvae, and Ceratopogonidae larvae. Two measures of community structure, Diversity (H) and Equitability (E), were calculated for each area each month. At Beach Nourishment Areas W-43.8, W-45.0, O-57.0, and O-75.8, H values were significantly different by month ( $P < 0.05$ ); however, at the other six areas, there were no significant differences by month ( $P > 0.05$ ). With the exception of Beach Nourishment Area W-43.8, E values were not significantly different by month ( $P > 0.05$ ).

Three sediment characteristics--median grain size (mm), percent silt/clay, and percent volatile solids--were described and compared for each beach nourishment area. Median grain sizes were not significantly different by month ( $P > 0.05$ ) in any of the 10 beach nourishment

areas; however, at Beach Nourishment Areas O-34.0, W-40.9, W-45.0, and O-57.0, median grain sizes were significantly higher ( $P < 0.05$ ) at sampling stations located 15 m from the high tide mark on the beach than at stations 30 m from the high tide mark. The regression relationship for median grain size and *Corophium* spp. density was significant ( $P < 0.05$ ); however, median grain size was a poor predictor of *Corophium* spp. density, explaining only 5% of the variation in *Corophium* spp. density (transformed). Percent silt/clay values were not significantly different by month ( $P > 0.05$ ) in any of the 10 beach nourishment areas. At Beach Nourishment Areas O-34.0, W-40.9, W-43.8, W-45.0, and O-57.0, percent silt/clay values were significantly lower ( $P < 0.05$ ) at sampling stations located 15 m from the high tide mark on the beach than at stations 30 m from the high tide mark. Percent volatile solids were not significantly different by month ( $P > 0.05$ ), except at Beach Nourishment Areas W-40.9, W-43.8, O-44.0, and W-70.1. At Beach Nourishment Areas O-34.0, W-45.0, O-45.1, O-47.8, and O-57.0, percent volatile solids were significantly ( $P < 0.05$ ) lower at sampling stations located 15 m from the high tide mark on the beach than at stations 30 m from the high tide mark.

All 10 beach nourishment areas supported substantial standing crops of *Corophium* spp. at times, particularly at stations along the 30-m transects. Since *Corophium* spp. are important prey for juvenile salmonids, and juvenile salmonids migrate along the beach nourishment areas, it is important to insure that *Corophium* spp. populations in these areas are not adversely impacted.



## CONTENTS

EXECUTIVE SUMMARY .....	iii
INTRODUCTION .....	1
METHODS .....	3
Sampling .....	3
Data Analyses .....	5
Benthic Invertebrates .....	5
Sediments .....	6
RESULTS .....	7
Beach Nourishment Area O-34.0 .....	7
Benthic Invertebrates .....	7
Sediments .....	16
Beach Nourishment Area W-40.9 .....	16
Benthic Invertebrates .....	16
Sediments .....	19
Beach Nourishment Area W-43.8 .....	25
Benthic Invertebrates .....	25
Sediments .....	32
Beach Nourishment Area O-44.0 .....	35
Benthic Invertebrates .....	35
Sediments .....	42
Beach Nourishment Area W-45.0 .....	42
Benthic Invertebrates .....	42
Sediments .....	46
Beach Nourishment Area O-45.1 .....	52
Benthic Invertebrates .....	52
Sediments .....	57
Beach Nourishment Area O-47.8 .....	60
Benthic Invertebrates .....	60
Sediments .....	66



Beach Nourishment Area O-57.0 .....	66
Benthic Invertebrates .....	66
Sediments .....	76
Beach Nourishment Area W-70.1 .....	78
Benthic Invertebrates .....	78
Sediments .....	84
Beach Nourishment Area O-75.8 .....	84
Benthic Invertebrates .....	84
Sediments .....	93
Grain Size/ <i>Corophium</i> spp. Relationship .....	93
DISCUSSION .....	93
ACKNOWLEDGMENTS .....	99
REFERENCES .....	100
APPENDIX .....	105

## INTRODUCTION

The lower Columbia River is an important shipping channel in the Pacific Northwest, requiring the maintenance of a navigational channel from the mouth of the river to Portland, Oregon. Annually, the U.S. Army Corps of Engineers (COE) is responsible for removing and disposing of almost 6.9 million m<sup>3</sup> (9 million yd<sup>3</sup>) of material from the bottom of the navigational channel. The dredged material is disposed of at three types of sites: in water, upland, and in shoreline (beach) areas. The third type, disposal of dredged material in a narrow band (about 30 m) onto beaches in the lower Columbia River, is commonly referred to as beach nourishment. Habitats affected by beach nourishment typically include both intertidal and shallow subtidal habitats.

In 1994, the Portland District of the COE contracted with the National Marine Fisheries Service (NMFS) to conduct four quarterly surveys at 10 previously used beach nourishment areas in the lower Columbia River (Fig. 1). Because the lower Columbia River is presently designated as critical habitat for endangered Snake River Pacific salmon (*Oncorhynchus* spp.), the COE is required to complete biological assessments of the 10 areas prior to any future disposal of dredged material in these areas. Benthic invertebrates, particularly the amphipod *Corophium salmonis*, found in intertidal and shallow subtidal habitats of the Columbia River estuary are seasonally important in the diets of juvenile salmonids (McCabe et al. 1983, 1986; Kim et al. 1986). Muir and Emmett (1988) found that *C. salmonis* and *C. spinicorne* were the dominant prey for juvenile salmonids collected during the spring of 1984 at Bonneville Dam. The overall goal of the present study was to describe the benthic invertebrate communities at the 10 beach nourishment areas. Specifically, we assessed benthic invertebrate species composition, standing crops, diversity, and equitability.

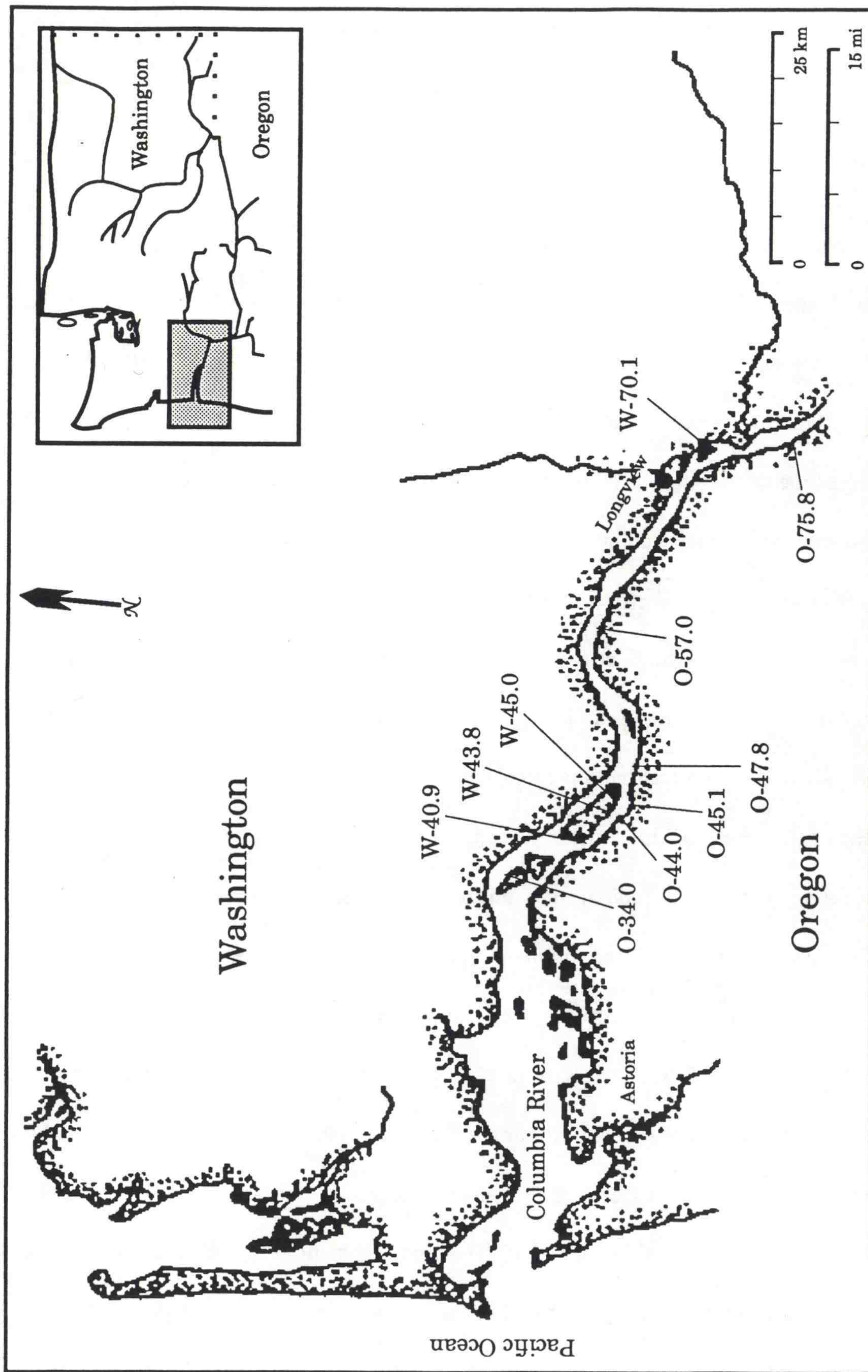

Figure 1. Locations of the 10 beach nourishment areas sampled in July and October 1994 and January and April 1995.

We also examined the relationship between sediment median grain size and standing crops of *Corophium* spp.

## METHODS

### Sampling

Benthic invertebrate and sediment samples were collected at the 10 beach nourishment areas in July and October 1994 and January and April 1995 (Fig. 1). At Beach Nourishment Area O-75.8, samples were actually collected on 1 August 1994, instead of in July. In addition, about 274 m (900 ft) of the upper end of Beach Nourishment Area O-74.5 is included with Beach Nourishment Area O-75.8. Each area is identified by an "O" or a "W," followed by a number. The "O" and "W" refer to Oregon and Washington, and the succeeding number refers to the approximate location in river miles from the mouth of the river (see U.S. Army Corps of Engineers 1991 for detailed navigational charts of the 10 beach nourishment areas).

Station locations (latitude and longitude) were established using the Global Positioning System, which also allowed stations to be easily reoccupied (Appendix Table 1). In each area, samples were collected along two parallel transects that were located about 15 m (50 ft) and 30 m (100 ft), respectively, from the high tide mark on the shore. The number of sampling stations along each transect in the 10 disposal areas varied depending upon the length and habitat diversity of the area (Table 1). Odd-numbered stations were located along the 15-m transect, and even-numbered stations along the 30-m transect. At Beach Nourishment Areas O-34.0 and O-57.0, two stations outside of the disposal areas were sampled to provide information about benthic invertebrates in undisturbed habitats.

Table 1. Numbers of sampling stations at 10 beach nourishment areas in the lower Columbia River, July 1994 through April 1995. The approximate lengths of the areas are also shown. In the "Area" column, the "O" and "W" refer to Oregon and Washington, and the succeeding number refers to the approximate location in river miles from the mouth of the river. Generally, 10 replicate samples were collected at each station.

Area	No. of stations	No. of station pairs <sup>a</sup>	Length of area (m)
O-34.0	10 <sup>b</sup>	5	1,524
W-40.9	6	3	762
W-43.8	8	4	1,219
O-44.0 <sup>c</sup>	18	9	3,658
W-45.0	10	5	1,585
O-45.1 <sup>c</sup>	4	2	457
O-47.8	6	3	914
O-57.0	8 <sup>b</sup>	4	1,265
W-70.1	14	7	2,896
O-75.8 <sup>d</sup>	8	4	1,524

<sup>a</sup> Each station pair consisted of two adjacent sampling stations located about 15 and 30 m, respectively, from the high tide mark.

<sup>b</sup> Does not include two sampling stations outside the beach nourishment area.

<sup>c</sup> Beach Nourishment Areas O-44.0 and O-45.1 are not separated by a line on the COE charts (U.S. Army Corps of Engineers 1991); 3,658 m of the combined area was defined as Area O-44.0 and 457 m of the combined area was defined as Area O-45.1.

<sup>d</sup> About 274 m of the upper end of Beach Nourishment Area O-74.5 is included with Beach Nourishment Area O-75.8.

Eleven core samples were taken at each of 96 stations (Fig. 1). Samples were collected with a polyvinyl chloride (PVC) coring device with an inside diameter of 3.85 cm, a penetrating depth of 15 cm, and a 174.6-cm<sup>3</sup> sample volume (Appendix Fig. 1). Samples were collected by commercial divers at depths greater than 0.9 m (3 ft). Ten core samples from each station were placed in labeled jars and preserved in a buffered formaldehyde solution ( $\geq 4\%$ ) containing rose bengal, a protein stain. In the laboratory, samples were washed with water through a 0.5-mm screen. All benthic invertebrates were sorted from each sample, identified to the lowest practical taxon, counted, and stored in 70% ethanol. The eleventh benthic sample from each station was placed in a labeled plastic bag and refrigerated for analysis of grain size, percent silt/clay, and percent volatile solids by the COE North Pacific Division Materials Laboratory, Troutdale, Oregon.

### Data Analyses

#### Benthic Invertebrates

Benthic invertebrate data were analyzed by station to determine species composition, densities (by taxon and total), and community structure (diversity and equitability). The Shannon-Wiener function (H) was used to determine diversity (Krebs 1978). Diversity is expressed as:

$$H = - \sum_{i=1}^s (p_i)(\log_2 p_i)$$

where  $p_i = n_i/N$  ( $n_i$  is the number of individuals of the  $i$ th taxon in the sample, and  $N$  is the total number of all individuals in the sample) and  $s$  = number of taxa.

Equitability (E) was the second community structure index determined; E measures the proportional abundances among the various taxa in a sample (Krebs 1978) and ranges from 0.00 to 1.00, with 1.00 indicating all taxa in the sample are numerically equal. Equitability is expressed as:

$$E = H/\log_2 s$$

where H = Shannon-Wiener function and s = number of taxa.

Both H and E were calculated for each sampling station.

At each of the 10 beach nourishment areas, total benthic invertebrate densities, *Corophium* spp. densities, H, and E were each compared between transects (15- and 30-m) and months using two-way analysis of variance (ANOVA) (Ryan et al. 1985); densities were transformed ( $\log_{10}(\text{density} + 1)$ ) prior to running ANOVA. Means from the 10 samples at each sampling station provided the basic data entries for all statistical tests.

### **Sediments**

Two-way ANOVA was used to compare median grain size between transects (15- and 30-m) and months. One high outlying value for median grain size (Area W-45.0, Station 5, July 1994) was removed prior to using ANOVA. Percent silt/clay and percent volatile solids values were compared using the Kruskal-Wallis test (Ryan et al. 1985) because of the non-normal distribution of the data.

The relationship between median grain size and *Corophium* spp. density was investigated by plotting the data from all 10 beach nourishment areas, and then using linear regression. *Corophium* spp. densities were transformed ( $\log_{10}(\text{density} + 1)$ ) prior to using regression. One regression was computed using data from all 4 months. The data were

combined in this manner because overall there were no significant differences ( $P > 0.05$ ) in *Corophium* spp. density or median grain size between months.

## RESULTS

### Beach Nourishment Area O-34.0

#### Benthic Invertebrates

At Beach Nourishment Area O-34.0, benthic invertebrate densities (total) were not significantly different between months (ANOVA,  $P > 0.05$ ) (Table 2); the lowest mean density occurred in July 1994 (14,113 organisms/m<sup>2</sup>) and the highest in January 1995 (29,246 organisms/m<sup>2</sup>) (Table 3). Benthic invertebrate densities were significantly different between the 15- and 30-m transects ( $P < 0.05$ ), with the highest densities occurring at stations along the 30-m transect (Tables 2 and 3). In the undisturbed area outside of the beach nourishment area (Stations 1 and 2), mean benthic invertebrate densities were lower than those in the beach nourishment area in all months (Table 3). No statistical analysis was performed because only two stations were sampled in the undisturbed area.

The mean numbers of taxa/categories collected in both the beach nourishment area and the undisturbed area were similar for each month, ranging from seven to eight (Table 4). Major benthic invertebrate taxa collected in the beach nourishment area included nemertean, oligochaetes, the bivalve *Corbicula fluminea*, *Corophium salmonis*, and Chironomidae larvae (Table 5). Summaries by station for all months and beach nourishment areas are available upon request from NMFS, Northwest Fisheries Science Center, Point Adams Biological Field Station, P.O. Box 155, Hammond, Oregon 97121.



Table 2. Results of two-way analysis of variance for selected benthic invertebrate parameters measured at Beach Nourishment Area O-34.0 in the lower Columbia River, July and October 1994 and January and April 1995. Five stations were sampled along both the 15-m and 30-m transects in the beach nourishment area; these parallel transects were located about 15 and 30 m from the high tide mark on the beach. A significant difference ( $P \leq 0.05$ ) is indicated with an \*.

Parameter	Source	Degrees of freedom	F	P value
Benthic invertebrate density ( $\log_{10}(\text{value} + 1)$ ), total	Month	3	0.49	0.689
	Transect	1	17.14	0.000*
	Total	39		
<i>Corophium</i> spp. density ( $\log_{10}(\text{value} + 1)$ )	Month	3	0.82	0.492
	Transect	1	19.59	0.000*
	Total	39		
Diversity (H)	Month	3	1.94	0.143
	Transect	1	0.00	0.953
	Total	39		
Equitability (E)	Month	3	2.08	0.122
	Transect	1	9.51	0.004*
	Total	39		

Table 3. Benthic invertebrate densities (number/m<sup>2</sup>) at Beach Nourishment Area O-34.0 and two stations (1 and 2) outside of the area in the lower Columbia River, July 1994 through April 1995. In the "Area" column, the "O" refers to Oregon, and the succeeding number refers to the approximate location in river miles from the mouth of the river. Generally, each density is the mean of 10 replicate samples collected at a station; the standard deviation (SD) is also shown for each density. Odd- and even-numbered stations were located about 15 and 30 m, respectively, from the high tide mark on the beach.

Area	Sta.	July		October		January		April	
		No./m <sup>2</sup>	SD	No./m <sup>2</sup>	SD	No./m <sup>2</sup>	SD	No./m <sup>2</sup>	SD
O-34.0	1	16,836	8,809	11,425	2,183	2,577	1,765	33,501	8,446
O-34.0	2	4,553	5,010	21,131	11,925	2,233	1,086	2,577	1,343
Mean		10,694		16,278		2,405		18,039	
O-34.0	3	2,663	2,607	3,608	1,934	1,718	1,280	1,374	724
O-34.0	4	5,927	3,301	23,622	7,886	93,974	25,412	66,658	8,965
O-34.0	5	5,068	2,160	16,664	6,644	6,271	2,027	35,734	6,632
O-34.0	6	71,382	31,529	75,076	53,620	73,530	63,438	96,722	33,014
O-34.0	7	5,841	3,359	5,154	2,218	1,288	928	3,608	2,555
O-34.0	8	26,629	12,958	27,745	9,651	51,625	13,463	35,820	11,142
O-34.0	9	344	601	258	415	344	444	0	0
O-34.0	10	4,381	2,819	6,528	2,722	3,350	6,120	430	607
O-34.0	11	3,007	2,783	4,381	2,933	3,951	2,112	1,374	1,526
O-34.0	12	15,891	6,570	31,697	13,536	56,407	12,201	11,768	3,190
Mean		14,113		19,473		29,246		25,349	

Table 4. Numbers of taxa/categories, Diversities (H), and Equitabilities (E) at Beach Nourishment Area O-34.0 and two stations (1 and 2) outside of the area in the lower Columbia River, July 1994 through April 1995. In the "Area" column, the "O" refers to Oregon, and the succeeding number refers to the approximate location in river miles from the mouth of the river. Odd- and even-numbered stations were located about 15 and 30 m, respectively, from the high tide mark on the beach.

Area	Sta.	July			October			January			April		
		No. taxa	H	E	No. taxa	H	E	No. taxa	H	E	No. taxa	H	E
O-34.0	1	9	1.02	0.32	7	1.33	0.47	8	2.53	0.84	9	0.87	0.27
O-34.0	2	7	1.96	0.70	7	1.16	0.41	9	2.92	0.92	7	2.42	0.86
Mean		8	1.49	0.51	7	1.25	0.44	8	2.72	0.88	8	1.64	0.56
O-34.0	3	5	1.80	0.78	5	1.67	0.72	6	1.98	0.77	6	2.13	0.82
O-34.0	4	7	2.51	0.90	9	1.78	0.56	11	0.83	0.24	12	1.06	0.30
O-34.0	5	10	2.33	0.70	10	2.04	0.61	7	2.69	0.96	15	1.57	0.40
O-34.0	6	9	0.75	0.24	17	1.29	0.31	12	1.27	0.35	15	1.09	0.28
O-34.0	7	4	1.30	0.65	4	1.65	0.82	6	2.23	0.86	4	1.49	0.75
O-34.0	8	14	2.11	0.55	8	2.16	0.72	11	0.82	0.24	12	1.36	0.38
O-34.0	9	2	0.81	0.81	2	0.92	0.92	2	0.81	0.81	0	0.00	0.00
O-34.0	10	8	2.03	0.68	7	2.33	0.83	4	1.32	0.66	2	0.72	0.72
O-34.0	11	4	1.60	0.80	5	1.22	0.53	4	1.16	0.58	4	1.19	0.59
O-34.0	12	9	1.99	0.63	15	1.99	0.51	15	1.64	0.42	7	1.33	0.48
Mean		7	1.72	0.67	8	1.71	0.65	8	1.48	0.59	8	1.19	0.47

Table 5. Mean densities (number/m<sup>2</sup>) and standard deviations (SD) of benthic invertebrates collected at Beach Nourishment Area O-34.0 and two stations (1 and 2) outside of the area in the lower Columbia River, July 1994 through April 1995. Five stations were sampled along both the 15-m and 30-m transects in the beach nourishment area; these parallel transects were located about 15 and 30 m from the high tide mark on the beach. Each density represents the mean of all samples collected along a particular transect. Any addition discrepancies in totals are due to rounding.

Taxon	July		October		January		April	
	No./m <sup>2</sup>	SD	No./m <sup>2</sup>	SD	No./m <sup>2</sup>	SD	No./m <sup>2</sup>	SD
<b>BEACH NOURISHMENT AREA (15-m)</b>								
Nemertea	309	689	567	1,106	189	359	172	521
Nematomorpha	0	0	0	0	17	122	0	0
Turbellaria	0	0	120	460	120	388	498	852
Oligochaeta	1,220	1,956	842	1,131	361	651	1,185	1,955
Fluminicola virens	309	1,080	292	663	189	529	0	0
Corbicula fluminea	550	993	1,873	1,914	928	1,645	464	761
Pisidium spp.	0	0	0	0	0	0	17	122
Ostracoda	17	122	34	170	0	0	309	710
Hyalella azteca	17	122	34	243	0	0	52	206
Corophium salmonis	498	1,345	1,873	3,785	464	871	5,291	10,891
Corophium spinicorne	0	0	0	0	0	0	86	313
Harpacticoida	0	0	17	122	0	0	17	122
Chironomidae larvae	120	348	17	122	0	0	34	170
Chironomidae pupae	17	122	0	0	0	0	0	0
Ceratopogonidae larvae	69	235	326	883	447	678	240	737
Trichoptera pupae	0	0	0	0	0	0	17	122
Ephemeroptera nymph	0	0	0	0	0	0	17	122
Collembola adult	258	986	0	0	0	0	0	0
Hydracarina	0	0	17	122	0	0	17	122
Total	3,384	3,082	6,013	6,565	2,714	2,594	8,418	14,196

Table 5. Continued.

Taxon	July		October		January		April	
	No./m <sup>2</sup>	SD	No./m <sup>2</sup>	SD	No./m <sup>2</sup>	SD	No./m <sup>2</sup>	SD
<b>BEACH NOURISHMENT AREA (30-m)</b>								
Nemertea	1,443	1,678	1,976	3,229	771	2,314	344	694
Nematomorpha	17	122	0	0	0	0	0	0
Turbellaria	155	376	309	667	210	512	344	950
Neanthes limnicola	17	122	52	206	0	0	0	0
Oligochaeta	13,486	28,195	13,795	31,263	14,200	34,732	17,575	34,645
Hirudinea	0	0	17	122	0	0	17	122
Juga plicifera	0	0	0	0	35	172	0	0
Fluminicola virens	584	942	1,134	1,756	421	896	258	434
Vorticifex effusus	0	0	34	170	0	0	0	0
Bivalvia	0	0	17	122	0	0	0	0
Corbicula fluminea	1,168	1,500	6,924	7,587	2,875	3,269	1,718	2,289
Pisidium spp.	0	0	292	912	210	755	481	1,277
Ostracoda	567	1,294	240	522	578	1,207	412	954
Hyaella azteca	0	0	34	170	105	334	206	564
Corophium spp.	189	583	0	0	0	0	0	0
Corophium salmonis	5,583	7,169	6,064	6,394	33,834	32,951	18,537	22,043
Corophium spinicorne	0	0	0	0	403	746	515	997
Pontoporeia hoyi	17	122	0	0	0	0	86	313
Ramellogammarus oregonensis	17	122	0	0	0	0	0	0
Asellus occidentalis	103	374	86	398	193	1,231	0	0
Harpacticoida	0	0	103	374	18	123	0	0
Chironomidae larvae	1,237	1,666	1,100	1,971	842	2,003	1,185	2,242
Chironomidae pupae	69	235	52	206	0	0	0	0
Ceratopogonidae larvae	120	348	309	689	316	600	430	700
Trichoptera larvae	0	0	155	449	35	172	17	122
Ephemeroptera nymph	0	0	69	340	123	351	137	402
Hydracarina	69	293	172	388	140	405	17	122
Total	24,842	29,022	32,934	33,464	55,308	43,312	42,280	39,010

Table 5. Continued.

Taxon	July		October		January		April	
	No./m <sup>2</sup>	SD	No./m <sup>2</sup>	SD	No./m <sup>2</sup>	SD	No./m <sup>2</sup>	SD
<b>OUTSIDE OF BEACH NOURISHMENT AREA (15-m)</b>								
Nemertea	86	272	0	0	0	0	258	580
Turbellaria	86	272	0	0	258	415	344	724
Neanthes limnicola	0	0	86	272	0	0	0	0
Oligochaeta	1,890	2,057	344	601	601	910	1,546	975
Fluminicola virens	0	0	258	580	86	272	0	0
Corbicula fluminea	258	415	2,921	1,471	430	607	945	1,429
Corophium salmonis	13,830	7,591	7,645	2,511	859	992	29,292	8,103
Corophium spiniorne	86	272	86	272	172	362	344	724
Pontoporeia hoyi	344	444	0	0	86	272	86	272
Chironomidae larvae	172	362	86	272	86	272	430	607
Ceratopogonidae larvae	86	272	0	0	0	0	258	415
Total	16,836	8,808	11,425	2,182	2,577	1,765	33,501	8,446
<b>OUTSIDE OF BEACH NOURISHMENT AREA (30-m)</b>								
Nemertea	2,405	4,701	0	0	515	601	601	580
Turbellaria	0	0	86	272	344	444	172	362
Neanthes limnicola	0	0	0	0	172	362	0	0
Oligochaeta	430	607	1,117	1,406	86	272	601	707
Fluminicola virens	86	272	1,374	1,864	258	415	0	0
Corbicula fluminea	86	272	1,374	1,471	344	601	773	945
Corophium salmonis	945	1,028	16,750	10,491	86	272	258	415
Harpacticoida	86	272	0	0	0	0	0	0
Chironomidae larvae	515	830	344	601	86	272	86	272
Ceratopogonidae larvae	0	0	86	272	344	444	86	272
Total	4,553	5,010	21,131	11,924	2,233	1,086	2,577	1,343

Densities of *Corophium* spp. were not significantly different (ANOVA,  $P > 0.05$ ) between months in Beach Nourishment Area O-34.0; however, densities were significantly higher ( $P < 0.05$ ) at stations along the 30-m transect compared to stations along the 15-m transect (Tables 2 and 5). Mean densities of *Corophium* spp. at stations along the 15-m transect ranged from 464 organisms/m<sup>2</sup> in January 1995 to 5,377 organisms/m<sup>2</sup> in April 1995. At stations along the 30-m transect, mean densities of *Corophium* spp. ranged from 5,772 organisms/m<sup>2</sup> in July 1994 to 34,237 organisms/m<sup>2</sup> in January 1995 (Table 5). Densities of *Corophium* spp. also varied spatially along each transect (Fig. 2). Mean densities of *Corophium* spp. along the 15-m transect in the undisturbed area (Station 1) outside of the beach area were higher than mean densities at stations along the 15-m transect in the beach nourishment area (Table 5). With the exception of October 1994, mean densities of *Corophium* spp. along the 30-m transect in the undisturbed area (Station 2) outside of the beach area were lower than mean densities at stations along the 30-m transect in the beach nourishment area.

Diversity (H) was not significantly different (ANOVA,  $P > 0.05$ ) between months or transects in Beach Nourishment Area O-34.0 (Table 2). Mean H values ranged from 1.19 in April 1995 to 1.72 in July 1994 (Table 4). Equitability (E) was not significantly different ( $P > 0.05$ ) between months; however, it was significantly higher ( $P < 0.05$ ) at stations along the 15-m transect (mean = 0.69) than at stations along the 30-m transect (mean = 0.50) (Tables 2 and 4). Diversity and Equitability did not follow any consistent monthly pattern in comparisons between the beach nourishment area and the undisturbed area outside of the beach nourishment area (Table 4).

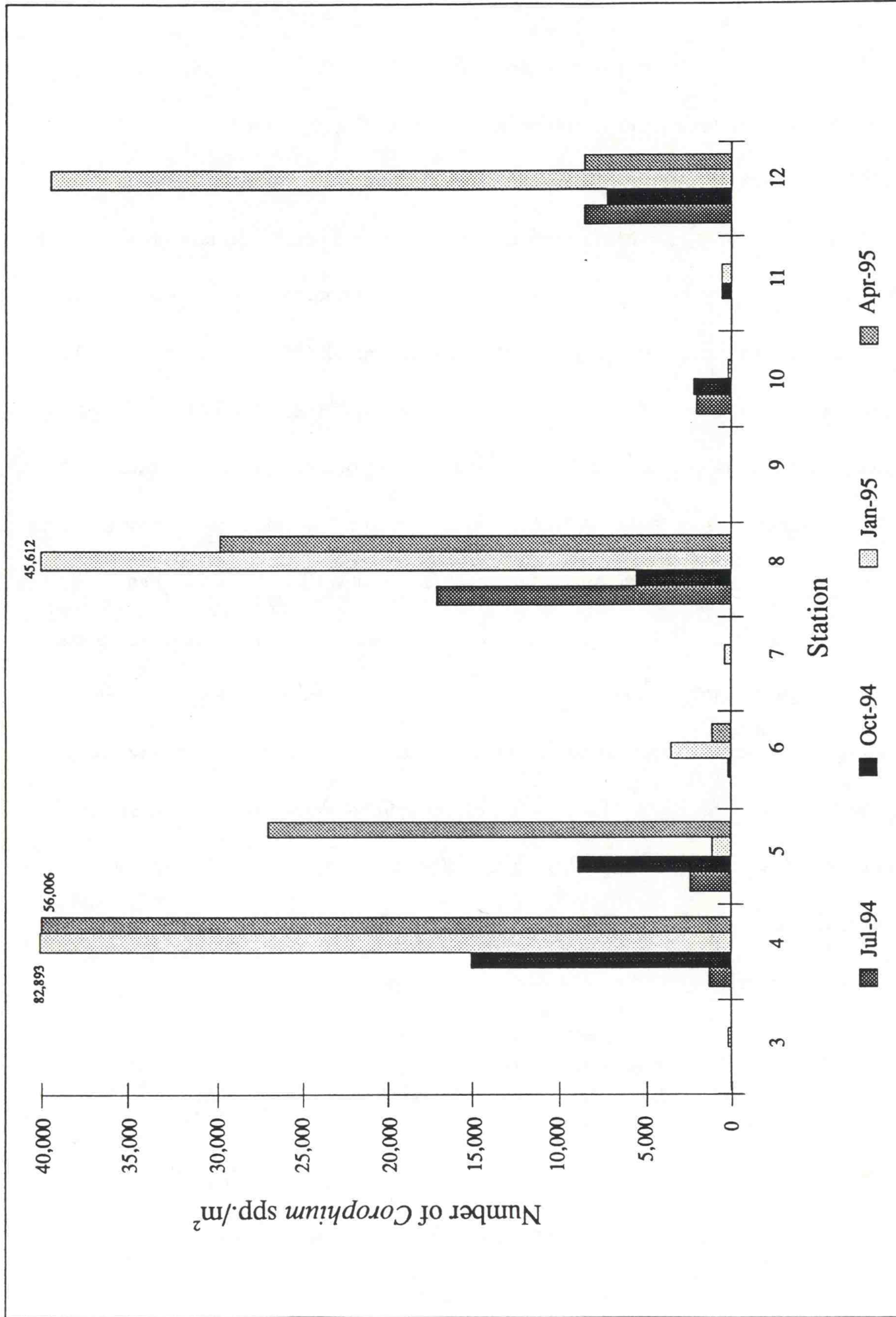

Figure 2. Number of *Corophium* spp./m<sup>2</sup> by station at Beach Nourishment Area O-34.0 in the lower Columbia River. Sampling was conducted in July and October 1994 and January and April 1995. Stations 1 and 2 were control stations outside the study area. Odd- and even-numbered stations were located about 15 and 30 m, respectively, from the high tide mark on the beach.



## **Sediments**

Median grain size was not significantly different (ANOVA,  $P > 0.05$ ) between months in Beach Nourishment Area O-34.0; however, it was significantly higher ( $P < 0.05$ ) at stations along the 15-m transect (mean = 0.39 mm) than at stations along the 30-m transect (mean = 0.26 mm) (Table 6). Mean median grain size in the beach nourishment area ranged from 0.31 mm in January 1995 to 0.33 mm in the other 3 months. Both percent silt/clay and percent volatile solids did not vary significantly between months (Kruskal-Wallis,  $P > 0.05$ ). Mean percent silt/clay ranged from 7.2% in July 1994 to 10.0% in April 1995, and mean percent volatile solids ranged from 0.8% in January and April 1995 to 1.3% in July 1994 (Table 6). At stations along the 15-m transect in the beach nourishment area, percent silt/clay and percent volatile solids were significantly lower (Kruskal-Wallis,  $P < 0.05$ ) than at stations along the 30-m transect. Mean median grain size was lower in the undisturbed area outside of the beach nourishment area compared to the beach nourishment area (Table 6). No statistical analysis was performed because only two stations were sampled in the undisturbed area. With the exception of July 1994, mean percent silt/clay values in the undisturbed area outside of the beach area were lower than mean values in the beach nourishment area. Mean percent volatile solids were 2.0% or less for both the undisturbed area and the beach nourishment area (Table 6).

### **Beach Nourishment Area W-40.9**

#### **Benthic Invertebrates**

At Beach Nourishment Area W-40.9, benthic invertebrate densities (total) were not significantly different between months (ANOVA,  $P > 0.05$ ) (Table 7); the lowest mean

Table 6. Sediment characteristics at Beach Nourishment Area O-34.0 and two stations (1 and 2) outside of the area in the lower Columbia River, July 1994 through April 1995. In the "Area" column, the "O" refers to Oregon, and the succeeding number refers to the approximate location in river miles from the mouth of the river.

Area	Sta.	Median grain size (mm)				silt/clay (%)				Volatile solids (%)			
		Jul	Oct	Jan	Apr	Jul	Oct	Jan	Apr	Jul	Oct	Jan	Apr
O-34.0	1	0.04	0.15	0.17	0.17	76.1	7.3	2.9	12.2	3.4	1.6	0.4	0.5
O-34.0	2	0.18	0.17	0.17	0.17	1.9	6.5	1.7	1.5	0.7	0.6	0.5	0.5
Mean		0.11	0.16	0.17	0.17	39.0	6.9	2.3	6.8	2.0	1.1	0.4	0.5
O-34.0	3	0.55	0.67	0.40	0.54	0.5	0.3	0.3	0.4	0.4	0.6	0.2	0.3
O-34.0	4	0.38	0.38	0.36	0.39	1.1	0.4	1.2	2.6	0.6	0.6	0.5	0.5
O-34.0	5	0.39	0.33	0.39	0.32	0.3	3.6	0.5	9.2	1.1	0.9	0.6	0.8
O-34.0	6	0.04	0.04	0.04	0.04	66.3	72.5	68.1	83.5	4.3	4.2	3.4	3.7
O-34.0	7	0.41	0.42	0.34	0.43	0.3	0.5	0.4	0.6	0.6	0.5	0.4	0.4
O-34.0	8	0.36	0.29	0.35	0.34	2.2	7.0	1.5	0.7	0.8	0.9	0.2	0.5
O-34.0	9	0.27	0.32	0.29	0.29	0.1	0.1	1.5	0.7	3.8	0.5	0.4	0.2
O-34.0	10	0.26	0.24	0.28	0.31	0.5	4.8	0.4	0.2	0.6	0.6	0.7	0.5
O-34.0	11	0.35	0.33	0.39	0.33	0.3	0.2	0.4	0.4	0.5	0.5	0.7	0.5
O-34.0	12	0.31	0.24	0.29	0.30	0.9	4.8	2.3	1.4	0.7	1.3	0.8	0.5
Mean		0.33	0.33	0.31	0.33	7.2	9.4	7.7	10.0	1.3	1.1	0.8	0.8

Table 7. Results of two-way analysis of variance for selected benthic invertebrate parameters measured at Beach Nourishment Area W-40.9 in the lower Columbia River, July and October 1994 and January and April 1995. Three stations were sampled along both the 15-m and 30-m transects in the beach nourishment area; these parallel transects were located about 15 and 30 m from the high tide mark on the beach. A significant difference ( $P \leq 0.05$ ) is indicated with an \*.

Parameter	Source	Degrees of freedom	F	P value
Benthic invertebrate density ( $\log_{10}(\text{value} + 1)$ ), total	Month	3	0.40	0.752
	Transect	1	17.51	0.001*
	Total	23		
<i>Corophium</i> spp. density ( $\log_{10}(\text{value} + 1)$ )	Month	3	0.39	0.763
	Transect	1	13.71	0.002*
	Total	23		
Diversity (H)	Month	3	0.48	0.700
	Transect	1	1.43	0.250
	Total	23		
Equitability (E)	Month	3	0.57	0.646
	Transect	1	3.28	0.089
	Total	23		

density occurred in July 1994 (9,635 organisms/m<sup>2</sup>) and the highest in January 1995 (25,426 organisms/m<sup>2</sup>) (Table 8). Benthic invertebrate densities were significantly different between the 15- and 30-m transects ( $P < 0.05$ ), with the highest densities generally occurring at stations along the 30-m transect (Tables 7 and 8).

The mean numbers of taxa/categories collected in the beach nourishment area were similar for each month, ranging from six to seven (Table 9). Major benthic invertebrate taxa collected in the beach nourishment area included nemerteans, oligochaetes, *Corbicula fluminea*, and *Corophium salmonis* (Table 10).

Densities of *Corophium* spp. were not significantly different (ANOVA,  $P > 0.05$ ) between months in Beach Nourishment Area W-40.9; however, densities were significantly higher ( $P < 0.05$ ) at stations along the 30-m transect compared to stations along the 15-m transect (Tables 7 and 10). Mean densities of *Corophium* spp. at stations along the 15-m transect ranged from 143 organisms/m<sup>2</sup> in July 1994 to 9,879 organisms/m<sup>2</sup> in January 1995. At stations along the 30-m transect, mean densities of *Corophium* spp. ranged from 10,050 organisms/m<sup>2</sup> in July 1994 to 30,609 organisms/m<sup>2</sup> in January 1995 (Table 10). Densities of *Corophium* spp. also varied spatially along each transect (Fig. 3).

Diversity (H) and Equitability (E) were not significantly different (ANOVA,  $P > 0.05$ ) between months or transects in Beach Nourishment Area W-40.9 (Table 7). Mean H values ranged from 1.31 in January 1995 to 1.72 in October 1994, and mean E values ranged from 0.58 in January 1995 to 0.76 in July 1994 (Table 9).

### Sediments

Median grain size was not significantly different (ANOVA,  $P > 0.05$ ) between months in Beach Nourishment Area W-40.9; however, it was significantly higher ( $P < 0.05$ ) at

Table 8. Benthic invertebrate densities (number/m<sup>2</sup>) at Beach Nourishment Area W-40.9 in the lower Columbia River, July 1994 through April 1995. In the "Area" column, the "W" refers to Washington, and the succeeding number refers to the approximate location in river miles from the mouth of the river. Generally, each density is the mean of 10 replicate samples collected at a station; the standard deviation (SD) is also shown for each density. Odd- and even-numbered stations were located about 15 and 30 m, respectively, from the high tide mark on the beach.

Area	Sta.	July		October		January		April	
		No./m <sup>2</sup>	SD	No./m <sup>2</sup>	SD	No./m <sup>2</sup>	SD	No./m <sup>2</sup>	SD
W-40.9	1	258	415	1,031	1,056	515	601	1,031	887
W-40.9	2	13,400	3,488	21,389	6,174	76,880	15,788	63,088	9,624
W-40.9	3	601	580	1,718	1,811	515	601	601	815
W-40.9	4	30,666	16,974	10,909	4,010	6,185	3,707	1,546	887
W-40.9	5	1,203	1,228	8,246	3,951	35,734	10,117	12,284	6,630
W-40.9	6	11,682	4,708	17,523	11,979	32,728	6,485	37,022	8,594
Mean		9,635		10,136		25,426		19,262	

Table 9. Numbers of taxa/categories, Diversities (H), and Equitabilities (E) at Beach Nourishment Area W-40.9 in the lower Columbia River, July 1994 through April 1995. In the "Area" column, the "W" refers to Washington, and the succeeding number refers to the approximate location in river miles from the mouth of the river. Odd- and even-numbered stations were located about 15 and 30 m, respectively, from the high tide mark on the beach.

Area	Sta.	July			October			January			April		
		No. taxa	H	E	No. taxa	H	E	No. taxa	H	E	No. taxa	H	E
W-40.9	1	3	1.58	1.00	3	1.38	0.87	2	0.65	0.65	6	2.13	0.82
W-40.9	2	9	2.09	0.66	8	1.07	0.36	9	0.65	0.20	7	0.64	0.23
W-40.9	3	3	1.45	0.91	4	1.96	0.98	3	1.58	1.00	3	1.38	0.87
W-40.9	4	9	1.90	0.60	7	1.76	0.63	7	2.42	0.86	8	2.77	0.92
W-40.9	5	3	1.26	0.80	8	1.96	0.65	10	1.05	0.32	6	0.54	0.21
W-40.9	6	8	1.73	0.58	10	2.18	0.66	9	1.52	0.48	10	1.93	0.58
Mean		6	1.67	0.76	7	1.72	0.69	7	1.31	0.58	7	1.56	0.60

Table 10. Mean densities (number/m<sup>2</sup>) and standard deviations (SD) of benthic invertebrates collected at Beach Nourishment Area W-40.9 in the lower Columbia River, July 1994 through April 1995. Three stations were sampled along both the 15-m and 30-m transects in the beach nourishment area; these parallel transects were located about 15 and 30 m from the high tide mark on the beach. Each density represents the mean of all samples collected along a particular transect. Any additional discrepancies in totals are due to rounding.

Taxon	July		October		January		April	
	No./m <sup>2</sup>	SD	No./m <sup>2</sup>	SD	No./m <sup>2</sup>	SD	No./m <sup>2</sup>	SD
<b>BEACH NOURISHMENT AREA (15-m)</b>								
Nemertea	0	0	0	0	29	157	29	157
Nematomorpha	29	157	0	0	0	0	0	0
Turbellaria	0	0	29	157	143	396	57	218
Oligochaeta	315	617	1,088	1,295	1,288	1,884	114	373
Planorbidae	0	0	29	157	0	0	0	0
Lymnaea spp.	0	0	0	0	29	157	0	0
Fluminicola virens	0	0	29	157	200	488	86	262
Vorticifex effusus	0	0	29	157	0	0	0	0
Corbicula fluminea	172	416	1,374	2,351	601	1,109	200	433
Corophium salmonis	143	396	773	1,066	9,850	14,951	4,066	6,384
Corophium spiniorne	0	0	0	0	29	157	0	0
Pontoporeia hoyi	0	0	0	0	0	0	29	157
Diptera pupae	0	0	0	0	29	157	0	0
Ceratopogonidae larvae	29	157	315	764	57	218	29	157
Trichoptera pupae	0	0	0	0	0	0	29	157
Total	687	885	3,665	4,141	12,255	17,808	4,638	6,660

Table 10. Continued.

Taxon	July		October		January		April	
	No./m <sup>2</sup>	SD	No./m <sup>2</sup>	SD	No./m <sup>2</sup>	SD	No./m <sup>2</sup>	SD
<b>BEACH NOURISHMENT AREA (30-m)</b>								
Nemertea	2,634	4,895	659	1,001	1,317	1,897	563	736
Turbellaria	0	0	200	665	172	350	296	619
Oligochaeta	2,863	2,475	1,489	1,371	4,266	4,277	2,992	2,583
Fluminicola virens	1,661	1,641	544	1,740	458	627	385	711
Corbicula fluminea	458	585	1,518	2,230	1,346	1,328	1,807	2,253
Ostracoda	143	396	29	157	0	0	0	0
Hyalella azteca	0	0	0	0	29	157	0	0
Corophium salmonis	10,050	8,021	10,795	6,579	30,380	30,851	25,533	24,295
Corophium spinicorne	0	0	29	157	229	501	267	404
Pontoporeia hoyi	0	0	0	0	0	0	681	2,401
Harpacticoida	0	0	0	0	29	157	0	0
Chironomidae larvae	258	460	0	0	0	0	89	266
Chironomidae pupae	115	297	0	0	0	0	0	0
Ceratopogonidae larvae	401	667	1,288	1,843	372	625	267	519
Hydracarina	0	0	57	218	0	0	0	0
<b>Total</b>	<b>18,583</b>	<b>13,270</b>	<b>16,607</b>	<b>8,985</b>	<b>38,597</b>	<b>31,212</b>	<b>32,879</b>	<b>26,468</b>



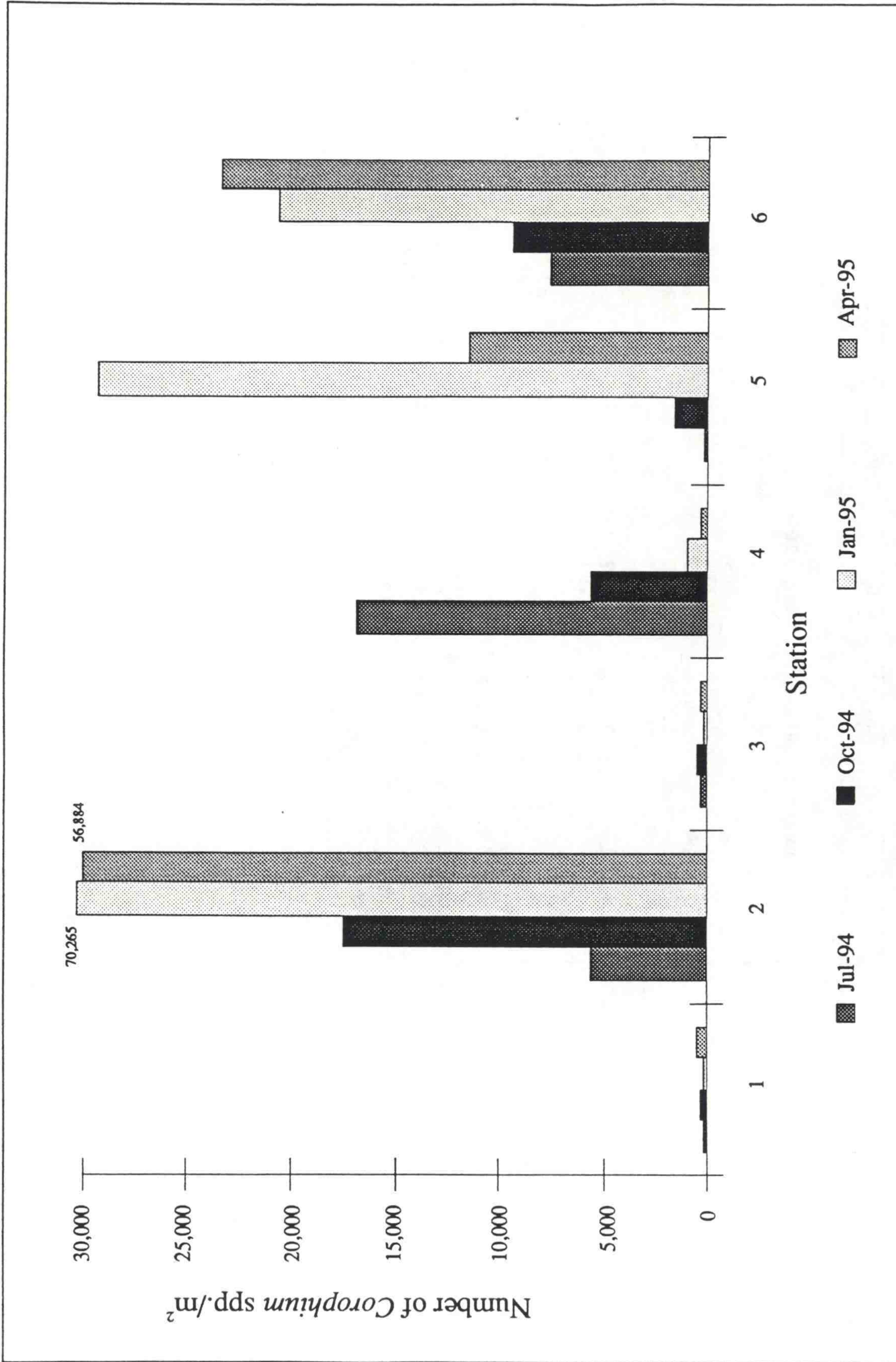

Figure 3. Number of *Corophium* spp./m<sup>2</sup> by station at Beach Nourishment Area W-40.9 in the lower Columbia River. Sampling was conducted in July and October 1994 and January and April 1995. Odd- and even-numbered stations were located about 15 and 30 m, respectively, from the high tide mark on the beach.

stations along the 15-m transect (mean = 0.37 mm) compared to stations along the 30-m transect (mean = 0.32 mm) (Table 11). Mean median grain size in the beach nourishment area ranged from 0.33 mm in January 1995 to 0.36 mm in October 1994. Percent silt/clay was not significantly different between months (Kruskal-Wallis,  $P > 0.05$ ), but was significantly lower at stations along the 15-m transect (Kruskal-Wallis,  $P < 0.05$ ) than at stations along the 30-m transect. Mean percent silt/clay ranged from 0.8% in July 1994 to 2.8% in April 1995 (Table 11). Percent volatile solids were significantly different between months (Kruskal-Wallis,  $P < 0.05$ ), but not significantly different between 15- and 30-m transects (Kruskal-Wallis,  $P > 0.05$ ). Mean percent volatile solids ranged from 0.4% in January 1995 to 0.8% in October 1994 (Table 11).

#### Beach Nourishment Area W-43.8

##### Benthic Invertebrates

At Beach Nourishment Area W-43.8, benthic invertebrate densities (total) were not significantly different between months (ANOVA,  $P > 0.05$ ) (Table 12); the lowest mean density occurred in July 1994 (3,060 organisms/m<sup>2</sup>) and the highest in January 1995 (27,273 organisms/m<sup>2</sup>) (Table 13). Benthic invertebrate densities were significantly different between the 15- and 30-m transects ( $P < 0.05$ ), with the highest densities generally occurring at stations along the 30-m transect (Tables 12 and 13).

The mean numbers of taxa/categories collected in the beach nourishment area were similar for each month, ranging from six to seven (Table 14). Major benthic invertebrate taxa collected in the beach nourishment area included nemertean, oligochaetes, *Corbicula fluminea*, *Corophium salmonis*, and Ceratopogonidae larvae (Table 15).

Table 11. Sediment characteristics at Beach Nourishment Area W-40.9 in the lower Columbia River, July 1994 through April 1995. In the "Area" column, the "W" refers to Washington, and the succeeding number refers to the approximate location in river miles from the mouth of the river.

Area	Sta.	Median grain size (mm)				silt/clay (%)				Volatile solids (%)			
		Jul	Oct	Jan	Apr	Jul	Oct	Jan	Apr	Jul	Oct	Jan	Apr
W-40.9	1	0.43	0.42	0.36	0.37	0.1	0.1	0.2	0.2	0.5	0.8	0.0	0.3
W-40.9	2	0.33	0.32	0.27	0.31	1.4	0.5	1.5	7.9	0.8	0.7	0.4	0.8
W-40.9	3	0.37	0.37	0.35	0.36	0.1	0.6	0.3	0.1	0.6	0.9	0.3	0.2
W-40.9	4	0.25	0.36	0.34	0.35	1.2	0.3	2.6	0.2	0.7	0.6	0.6	0.4
W-40.9	5	0.42	0.35	0.33	0.34	0.4	0.7	1.5	0.4	0.8	0.9	0.8	0.6
W-40.9	6	0.29	0.36	0.34	0.28	1.3	5.7	1.1	8.2	0.9	0.8	0.2	0.8
Mean		0.35	0.36	0.33	0.34	0.8	1.3	1.2	2.8	0.7	0.8	0.4	0.5

Table 12. Results of two-way analysis of variance for selected benthic invertebrate parameters measured at Beach Nourishment Area W-43.8 in the lower Columbia River, July and October 1994 and January and April 1995. Four stations were sampled along both the 15-m and 30-m transects in the beach nourishment area; these parallel transects were located about 15 and 30 m from the high tide mark on the beach. A significant difference ( $P \leq 0.05$ ) is indicated with an \*.

Parameter	Source	Degrees of freedom	F	P value
Benthic invertebrate density ( $\log_{10}(\text{value} + 1)$ ), total	Month	3	0.38	0.771
	Transect	1	7.42	0.012*
	Total	31		
<i>Corophium</i> spp. density ( $\log_{10}(\text{value} + 1)$ )	Month	3	1.01	0.404
	Transect	1	7.30	0.012*
	Total	31		
Diversity (H)	Month	3	5.58	0.005*
	Transect	1	0.30	0.591
	Total	31		
Equitability (E)	Month	3	4.51	0.012*
	Transect	1	1.66	0.210
	Total	31		

Table 13. Benthic invertebrate densities (number/m<sup>2</sup>) at Beach Nourishment Area W-43.8 in the lower Columbia River, July 1994 through April 1995. In the "Area" column, the "W" refers to Washington, and the succeeding number refers to the approximate location in river miles from the mouth of the river. Generally, each density is the mean of 10 replicate samples collected at a station; the standard deviation (SD) is also shown for each density. Odd- and even-numbered stations were located about 15 and 30 m, respectively, from the high tide mark on the beach.

Area	Sta.	July		October		January		April	
		No./m <sup>2</sup>	SD	No./m <sup>2</sup>	SD	No./m <sup>2</sup>	SD	No./m <sup>2</sup>	SD
W-43.8	1	1,718	859	8,113	2,652	1,288	1,581	2,749	1,504
W-43.8	2	4,639	2,333	14,221	7,252	1,288	928	4,467	3,359
W-43.8	3	1,031	1,391	601	580	86	272	430	730
W-43.8	4	4,896	3,032	18,382	4,691	48,705	25,119	64,854	15,098
W-43.8	5	1,718	1,620	3,178	2,106	60,902	24,462	1,288	1,090
W-43.8	6	3,350	1,485	18,125	7,112	86	272	43,379	12,109
W-43.8	7	859	1,620	773	752	57,123	12,417	773	634
W-43.8	8	6,271	6,630	13,744	6,567	48,705	14,482	38,483	7,617
Mean		3,060		9,642		27,273		19,553	

Table 14. Numbers of taxa/categories, Diversities (H), and Equitabilities (E) at Beach Nourishment Area W-43.8 in the lower Columbia River, July 1994 through April 1995. In the "Area" column, the "W" refers to Washington, and the succeeding number refers to the approximate location in river miles from the mouth of the river. Odd- and even-numbered stations were located about 15 and 30 m, respectively, from the high tide mark on the beach.

Area	Sta.	July			October			January			April		
		No. taxa	H	E	No. taxa	H	E	No. taxa	H	E	No. taxa	H	E
W-43.8	1	5	1.95	0.84	6	1.73	0.67	5	1.77	0.76	4	1.64	0.82
W-43.8	2	8	2.63	0.88	6	1.70	0.66	2	0.97	0.97	6	2.15	0.83
W-43.8	3	5	1.95	0.84	4	1.84	0.92	1	0.00	0.00	2	0.97	0.97
W-43.8	4	8	2.51	0.84	11	1.85	0.54	8	0.84	0.28	10	1.09	0.33
W-43.8	5	5	1.91	0.82	5	1.65	0.71	9	1.31	0.41	6	2.44	0.94
W-43.8	6	7	2.37	0.84	10	2.15	0.65	1	0.00	0.00	8	1.65	0.55
W-43.8	7	6	2.16	0.84	4	1.45	0.72	10	1.42	0.43	4	1.45	0.72
W-43.8	8	5	1.24	0.53	8	2.39	0.80	10	1.94	0.58	10	1.83	0.55
Mean		6	2.09	0.80	7	1.85	0.71	6	1.03	0.43	6	1.65	0.71

Table 15. Mean densities (number/m<sup>2</sup>) and standard deviations (SD) of benthic invertebrates collected at Beach Nourishment Area W-43.8 in the lower Columbia River, July 1994 through April 1995. Four stations were sampled along both the 15-m and 30-m transects in the beach nourishment area; these parallel transects were located about 15 and 30 m from the high tide mark on the beach. Each density represents the mean of all samples collected along a particular transect. Any additional discrepancies in totals are due to rounding.

Taxon	July		October		January		April	
	No./m <sup>2</sup>	SD	No./m <sup>2</sup>	SD	No./m <sup>2</sup>	SD	No./m <sup>2</sup>	SD
<b>BEACH NOURISHMENT AREA (15-m)</b>								
Nemertea	220	548	198	416	430	953	279	656
Turbellaria	0	0	22	138	279	563	236	476
Oligochaeta	308	502	220	471	880	1,436	43	190
Hirudinea	0	0	22	138	0	0	0	0
<i>Fluminicola virens</i>	44	192	22	138	880	1,396	43	272
<i>Corbicula fluminea</i>	419	707	1,079	1,497	2,255	2,967	22	136
<i>Corophium salmonis</i>	132	504	308	638	22,591	25,158	494	1,027
<i>Corophium spinicorne</i>	22	138	0	0	1,181	1,658	0	0
Harpacticoida	0	0	0	0	22	136	0	0
Tipulidae larvae	0	0	0	0	22	136	0	0
Chironomidae larvae	22	138	0	0	64	229	0	0
Ceratopogonidae larvae	154	388	1,167	2,118	1,246	2,358	193	363
Total	1,322	1,419	3,040	3,429	29,850	32,381	1,310	1,348

Table 15. Continued.

Taxon	July		October		January		April	
	No./m <sup>2</sup>	SD	No./m <sup>2</sup>	SD	No./m <sup>2</sup>	SD	No./m <sup>2</sup>	SD
<b>BEACH NOURISHMENT AREA (30-m)</b>								
Nemertea	601	1,641	1,300	2,047	1,095	3,836	1,654	2,959
Turbellaria	22	136	154	388	365	970	601	807
Neanthes limnicola	22	136	0	0	0	0	0	0
Oligochaeta	1,740	3,698	1,894	2,160	1,310	2,175	3,071	3,130
Gastropoda	22	136	44	192	0	0	0	0
Fluminicola virens	107	443	705	1,305	64	229	150	384
Corbicula fluminea	601	874	2,247	1,714	1,976	3,027	2,512	2,517
Pisidium spp.	0	0	0	0	0	0	43	272
Ostracoda	22	136	0	0	0	0	0	0
Corophium spp.	129	415	0	0	0	0	0	0
Corophium salmonis	859	933	7,797	5,502	18,103	22,309	26,736	21,234
Corophium sp. hoi	0	0	22	138	687	1,186	1,654	3,338
Pontoporeia hoyi	0	0	0	0	0	0	22	136
Harpacticoida	0	0	110	291	64	301	0	0
Chironomidae larvae	22	136	66	232	0	0	129	458
Ceratopogonidae larvae	644	842	1,828	1,410	1,009	1,480	1,224	1,081
Hydracarina	0	0	0	0	22	136	0	0
Total	4,789	3,890	16,167	6,574	24,696	28,029	37,796	24,148



Densities of *Corophium* spp. were not significantly different (ANOVA,  $P > 0.05$ ) between months in Beach Nourishment Area W-43.8; however, densities were significantly higher ( $P < 0.05$ ) at stations along the 30-m transect compared to stations along the 15-m transect (Tables 12 and 15). Mean densities of *Corophium* spp. at stations along the 15-m transect ranged from 154 organisms/m<sup>2</sup> in July 1994 to 23,772 organisms/m<sup>2</sup> in January 1995. At stations along the 30-m transect, mean densities of *Corophium* spp. ranged from 988 organisms/m<sup>2</sup> in July 1994 to 28,390 organisms/m<sup>2</sup> in April 1995 (Table 15). Densities of *Corophium* spp. also varied spatially along each transect (Fig. 4).

Diversity (H) and Equitability (E) were significantly different (ANOVA,  $P < 0.05$ ) between months, but not between transects in Beach Nourishment Area W-43.8 (Table 12). Mean H values ranged from 1.03 in January 1995 to 2.09 in July 1994, and mean E values ranged from 0.43 in January 1995 to 0.80 in July 1994 (Table 14).

### Sediments

Median grain size was not significantly different (ANOVA,  $P > 0.05$ ) between months or transects in Beach Nourishment Area W-43.8. Mean median grain size in the beach nourishment area ranged from 0.39 mm in July and October 1994 to 0.41 mm in January 1995 (Table 16). Percent silt/clay was not significantly different between months (Kruskal-Wallis,  $P > 0.05$ ), but was significantly lower at stations along the 15-m transect (Kruskal-Wallis,  $P < 0.05$ ) than at stations along the 30-m transect. Mean percent silt/clay ranged from 0.4% in January and April 1995 to 1.6% in October 1994 (Table 16). Percent volatile solids were significantly different between months (Kruskal-Wallis,  $P < 0.05$ ), but not significantly different between 15- and 30-m transects (Kruskal-Wallis,  $P > 0.05$ ). Mean percent volatile solids ranged from 0.3% in January 1995 to 1.1% in July 1994 (Table 16).

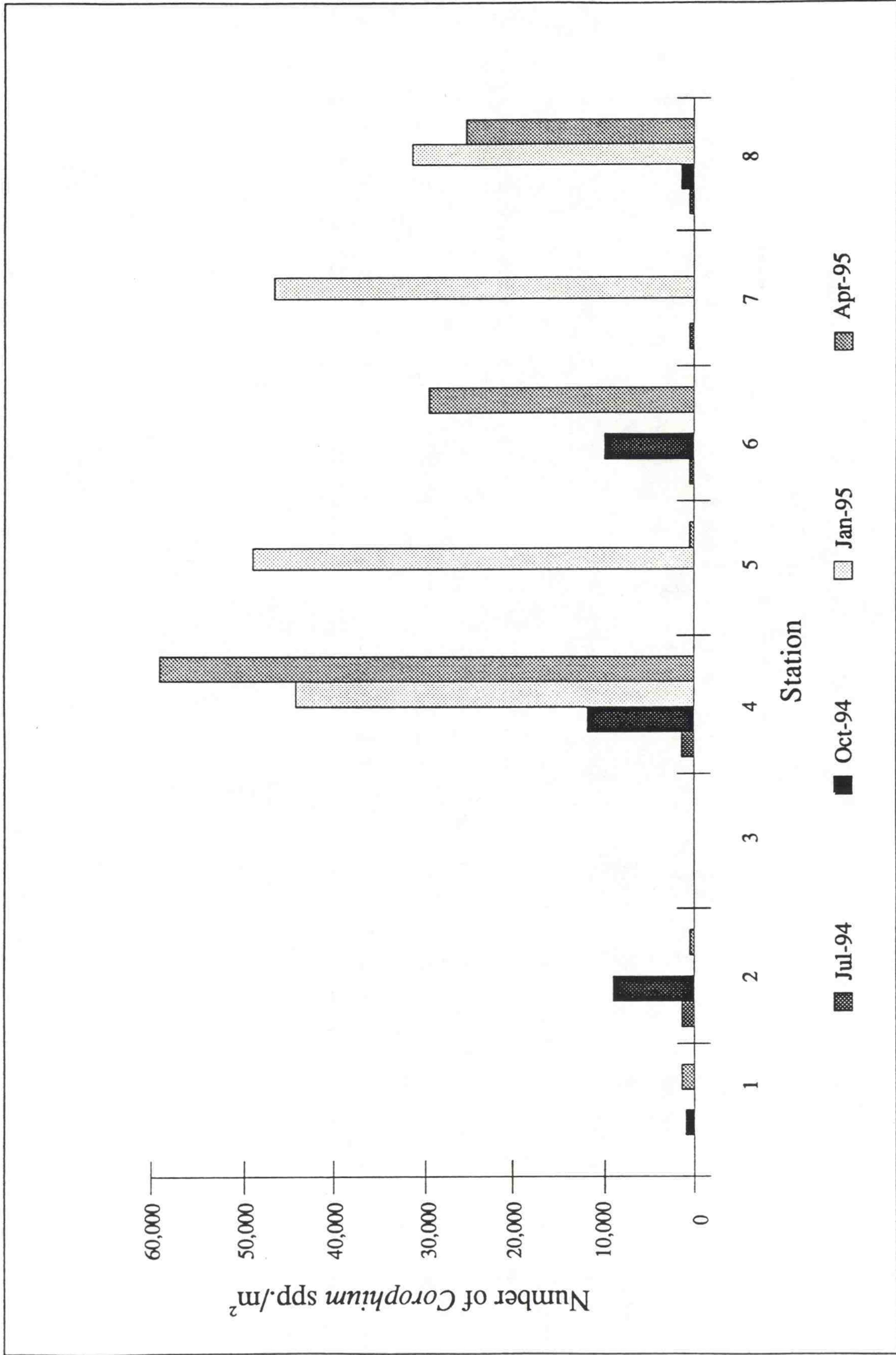

Figure 4. Number of *Corophium* spp./m<sup>2</sup> by station at Beach Nourishment Area W-43.8 in the lower Columbia River. Sampling was conducted in July and October 1994 and January and April 1995. Odd- and even-numbered stations were located about 15 and 30 m, respectively, from the high tide mark on the beach.

Table 16. Sediment characteristics at Beach Nourishment Area W-43.8 in the lower Columbia River, July 1994 through April 1995. In the "Area" column, the "W" refers to Washington, and the succeeding number refers to the approximate location in river miles from the mouth of the river.

Area	sta.	Median grain size (mm)				silt/clay (%)				Volatile solids (%)			
		Jul	Oct	Jan	Apr	Jul	Oct	Jan	Apr	Jul	Oct	Jan	Apr
W-43.8	1	0.39	0.38	0.34	0.34	0.3	0.4	0.1	0.2	2.8	0.4	0.4	0.4
W-43.8	2	0.36	0.33	0.33	0.39	0.3	4.3	0.1	0.6	0.7	0.5	0.5	0.5
W-43.8	3	0.40	0.33	0.35	0.36	0.7	0.5	0.3	0.1	0.7	0.6	0.2	0.5
W-43.8	4	0.25	0.45	0.55	0.57	8.6	2.9	0.5	0.3	2.0	0.5	0.5	0.4
W-43.8	5	0.38	0.37	0.45	0.34	0.0	0.2	0.4	0.1	0.7	0.6	0.3	0.3
W-43.8	6	0.58	0.37	0.34	0.41	0.2	3.5	0.1	0.6	0.5	0.3	0.0	0.7
W-43.8	7	0.34	0.35	0.43	0.39	0.3	0.3	1.1	0.2	0.6	0.7	0.0	0.5
W-43.8	8	0.44	0.51	0.48	0.44	1.3	0.8	1.0	1.4	0.7	0.5	0.5	0.7
Mean		0.39	0.39	0.41	0.40	1.5	1.6	0.4	0.4	1.1	0.5	0.3	0.5

### Beach Nourishment Area O-44.0

#### Benthic Invertebrates

At Beach Nourishment Area O-44.0, benthic invertebrate densities (total) were not significantly different between months (ANOVA,  $P > 0.05$ ) (Table 17); the lowest mean density occurred in October 1994 (2,802 organisms/m<sup>2</sup>) and the highest in January 1995 (6,826 organisms/m<sup>2</sup>) (Table 18). Benthic invertebrate densities were significantly different between the 15- and 30-m transects ( $P < 0.05$ ), with the highest densities generally occurring at stations along the 30-m transect (Tables 17 and 18).

The mean number of taxa/categories collected in the beach nourishment area in each month was four (Table 19). Major benthic invertebrate taxa collected in the beach nourishment area included oligochaetes, *Corbicula fluminea*, and *Corophium salmonis* (Table 20).

Densities of *Corophium* spp. were not significantly different (ANOVA,  $P > 0.05$ ) between months in Beach Nourishment Area O-44.0; however, densities were significantly higher ( $P < 0.05$ ) at stations along the 30-m transect than at stations along the 15-m transect (Tables 17 and 20). Mean densities of *Corophium* spp. at stations along the 15-m transect ranged from 10 organisms/m<sup>2</sup> in October 1994 to 95 organisms/m<sup>2</sup> in January and April 1995. At stations along the 30-m transect, mean densities of *Corophium* spp. ranged from 2,358 organisms/m<sup>2</sup> in October 1994 to 9,536 organisms/m<sup>2</sup> in January 1995 (Table 20). Densities of *Corophium* spp. also varied spatially along each transect (Fig. 5).

Diversity (H) and Equitability (E) were not significantly different (ANOVA,  $P > 0.05$ ) between months in Beach Nourishment Area O-44.0 (Table 17). Mean H values ranged from

Table 17. Results of two-way analysis of variance for selected benthic invertebrate parameters measured at Beach Nourishment Area O-44.0 in the lower Columbia River, July and October 1994 and January and April 1995. Nine stations were sampled along both the 15-m and 30-m transects in the beach nourishment area; these parallel transects were located about 15 and 30 m from the high tide mark on the beach. A significant difference ( $P \leq 0.05$ ) is indicated with an \*.

Parameter	Source	Degrees of freedom	F	P value
Benthic invertebrate density ( $\log_{10}(\text{value} + 1)$ ), total	Month	3	0.61	0.613
	Transect	1	20.49	0.000*
	Total	71		
<i>Corophium</i> spp. density ( $\log_{10}(\text{value} + 1)$ )	Month	3	0.58	0.628
	Transect	1	30.48	0.000*
	Total	71		
Diversity (H)	Month	3	0.57	0.639
	Transect	1	12.80	0.001*
	Total	71		
Equitability (E)	Month	3	1.06	0.373
	Transect	1	0.66	0.419
	Total	71		

Table 18. Benthic invertebrate densities (number/m<sup>2</sup>) at Beach Nourishment Area O-44.0 in the lower Columbia River, July 1994 through April 1995. In the "Area" column, the "O" refers to Oregon, and the succeeding number refers to the approximate location in river miles from the mouth of the river. Generally, each density is the mean of 10 replicate samples collected at a station; the standard deviation (SD) is also shown for each density. Odd- and even-numbered stations were located about 15 and 30 m, respectively, from the high tide mark on the beach.

Area	Sta.	July		October		January		April	
		No./m <sup>2</sup>	SD	No./m <sup>2</sup>	SD	No./m <sup>2</sup>	SD	No./m <sup>2</sup>	SD
O-44.0	1	172	362	945	945	1,031	975	3,694	2,220
O-44.0	2	15,977	4,567	14,603	5,106	48,018	11,995	34,102	5,784
O-44.0	3	2,491	2,307	4,381	3,632	1,546	789	3,178	1,767
O-44.0	4	8,075	4,638	3,350	2,271	2,004	1,288	4,209	2,271
O-44.0	5	258	415	1,374	1,774	430	453	945	752
O-44.0	6	4,295	1,811	12,112	4,517	31,267	9,937	26,972	5,061
O-44.0	7	1,890	2,057	687	543	773	854	859	573
O-44.0	8	515	601	859	906	1,203	1,008	2,062	1,414
O-44.0	9	172	543	1,374	830	3,522	4,625	859	810
O-44.0	10	12,026	7,049	7,130	2,865	23,794	4,343	32,728	6,421
O-44.0	11	430	607	191	379	344	444	86	272
O-44.0	12	430	453	86	272	515	830	430	607
O-44.0	13	430	453	172	362	687	887	86	272
O-44.0	14	258	415	258	415	1,031	1,610	344	601
O-44.0	15	0	0	172	362	172	362	86	272
O-44.0	16	773	634	1,203	1,630	773	752	1,117	1,218
O-44.0	17	344	444	172	362	258	580	0	0
O-44.0	18	3,722	2,648	1,374	1,008	5,498	1,471	1,031	543
		-----		-----		-----		-----	
Mean		2,903		2,802		6,826		6,266	

Table 19. Numbers of taxa/categories, Diversities (H), and Equitabilities (E) at Beach Nourishment Area O-44.0 in the lower Columbia River, July 1994 through April 1995. In the "Area" column, the "O" refers to Oregon, and the succeeding number refers to the approximate location in river miles from the mouth of the river. Odd- and even-numbered stations were located about 15 and 30 m, respectively, from the high tide mark on the beach.

Area	Sta.	July			October			January			April		
		No. taxa	H	E	No. taxa	H	E	No. taxa	H	E	No. taxa	H	E
O-44.0	1	1	0.00	0.00	4	1.28	0.64	5	1.96	0.84	5	1.15	0.49
O-44.0	2	10	2.05	0.62	10	1.49	0.45	11	1.29	0.37	8	0.93	0.31
O-44.0	3	4	1.89	0.94	6	1.53	0.59	3	1.25	0.79	7	2.39	0.85
O-44.0	4	9	2.23	0.70	6	2.31	0.89	5	1.97	0.85	6	1.86	0.72
O-44.0	5	2	0.92	0.92	4	1.76	0.88	3	1.37	0.86	4	1.82	0.91
O-44.0	6	7	2.21	0.79	6	1.32	0.51	8	1.18	0.39	7	0.95	0.34
O-44.0	7	1	0.00	0.00	2	0.81	0.81	2	0.50	0.50	4	1.72	0.86
O-44.0	8	4	1.79	0.90	3	0.92	0.58	5	1.87	0.81	3	1.14	0.72
O-44.0	9	1	0.00	0.00	4	1.80	0.90	7	2.19	0.78	3	1.36	0.86
O-44.0	10	6	1.69	0.65	8	2.42	0.81	7	1.47	0.52	8	1.10	0.37
O-44.0	11	3	1.52	0.96	2	1.00	1.00	2	0.81	0.81	1	0.00	0.00
O-44.0	12	3	1.52	0.96	1	0.00	0.00	4	1.92	0.96	3	1.52	0.96
O-44.0	13	2	0.72	0.72	2	1.00	1.00	3	1.30	0.82	1	0.00	0.00
O-44.0	14	3	1.58	1.00	3	1.58	1.00	3	0.82	0.52	3	1.50	0.95
O-44.0	15	0	0.00	0.00	2	1.00	1.00	2	1.00	1.00	1	0.00	0.00
O-44.0	16	3	1.22	0.77	3	1.09	0.69	5	2.06	0.89	3	1.53	0.96
O-44.0	17	2	1.00	1.00	1	0.00	0.00	2	0.92	0.92	0	0.00	0.00
O-44.0	18	5	1.29	0.56	5	2.11	0.91	4	1.17	0.58	4	1.61	0.81
Mean		4	1.20	0.64	4	1.30	0.70	4	1.39	0.73	4	1.14	0.56

Table 20. Mean densities (number/m<sup>2</sup>) and standard deviations (SD) of benthic invertebrates collected at Beach Nourishment Area O-44.0 in the lower Columbia River, July 1994 through April 1995. Nine stations were sampled along both the 15-m and 30-m transects in the beach nourishment area; these parallel transects were located about 15 and 30 m from the high tide mark on the beach. Each density represents the mean of all samples collected along a particular transect. Any addition discrepancies in totals are due to rounding.

Taxon	July		October		January		April	
	No./m <sup>2</sup>	SD	No./m <sup>2</sup>	SD	No./m <sup>2</sup>	SD	No./m <sup>2</sup>	SD
<b>BEACH NOURISHMENT AREA (15-m)</b>								
Nemertea	153	570	48	199	162	589	67	391
Turbellaria	0	0	126	379	67	265	172	391
Oligochaeta	325	925	376	697	296	982	477	1,116
Corbicula fluminea	124	304	434	1,256	258	522	162	480
Ostracoda	0	0	10	91	10	90	19	127
Corophium salmonis	76	306	10	91	95	396	95	374
Ceratopogonidae larvae	10	91	39	179	86	259	95	374
Collembola adult	0	0	10	91	0	0	0	0
Hydracarina	0	0	10	91	0	0	0	0
<b>Total</b>	<b>687</b>	<b>1,339</b>	<b>1,062</b>	<b>1,886</b>	<b>974</b>	<b>1,885</b>	<b>1,088</b>	<b>1,653</b>



Table 20. Continued.

Taxon	July		October		January		April	
	No./m <sup>2</sup>	SD	No./m <sup>2</sup>	SD	No./m <sup>2</sup>	SD	No./m <sup>2</sup>	SD
BEACH NOURISHMENT AREA (30-m)								
Nemertea	637	1,439	344	726	348	876	95	300
Nematomorpha	19	182	0	0	0	0	0	0
Turbellaria	29	156	57	216	174	433	258	624
Neanthes limnicola	0	0	10	90	0	0	0	0
Oligochaeta	743	1,533	439	1,000	1,390	2,390	954	1,482
Gastropoda	0	0	38	178	0	0	0	0
Fluminicola virens	19	128	10	90	10	91	0	0
Corbicula fluminea	367	592	1,002	1,230	849	1,204	200	408
Hyaella azteca	0	0	10	90	10	91	10	90
Eogammarus confervicolus	0	0	10	90	0	0	0	0
Corophium spp.	145	676	0	0	0	0	0	0
Corophium salmonis	2,741	3,574	2,348	4,378	9,343	13,561	8,771	12,822
Corophium spinicorne	10	91	10	91	193	590	439	1,346
Harpacticoida	19	128	0	0	0	0	0	0
Chironomidae larvae	48	199	10	90	29	156	143	392
Ceratopogonidae larvae	357	837	258	553	444	926	534	1,177
Ephemeroptera nymph	0	0	0	0	10	91	19	181
Collembola adult	0	0	0	0	0	0	10	90
Hydracarina	0	0	10	90	0	0	10	90
Total	5,135	6,351	4,553	5,784	12,798	17,425	11,444	14,636

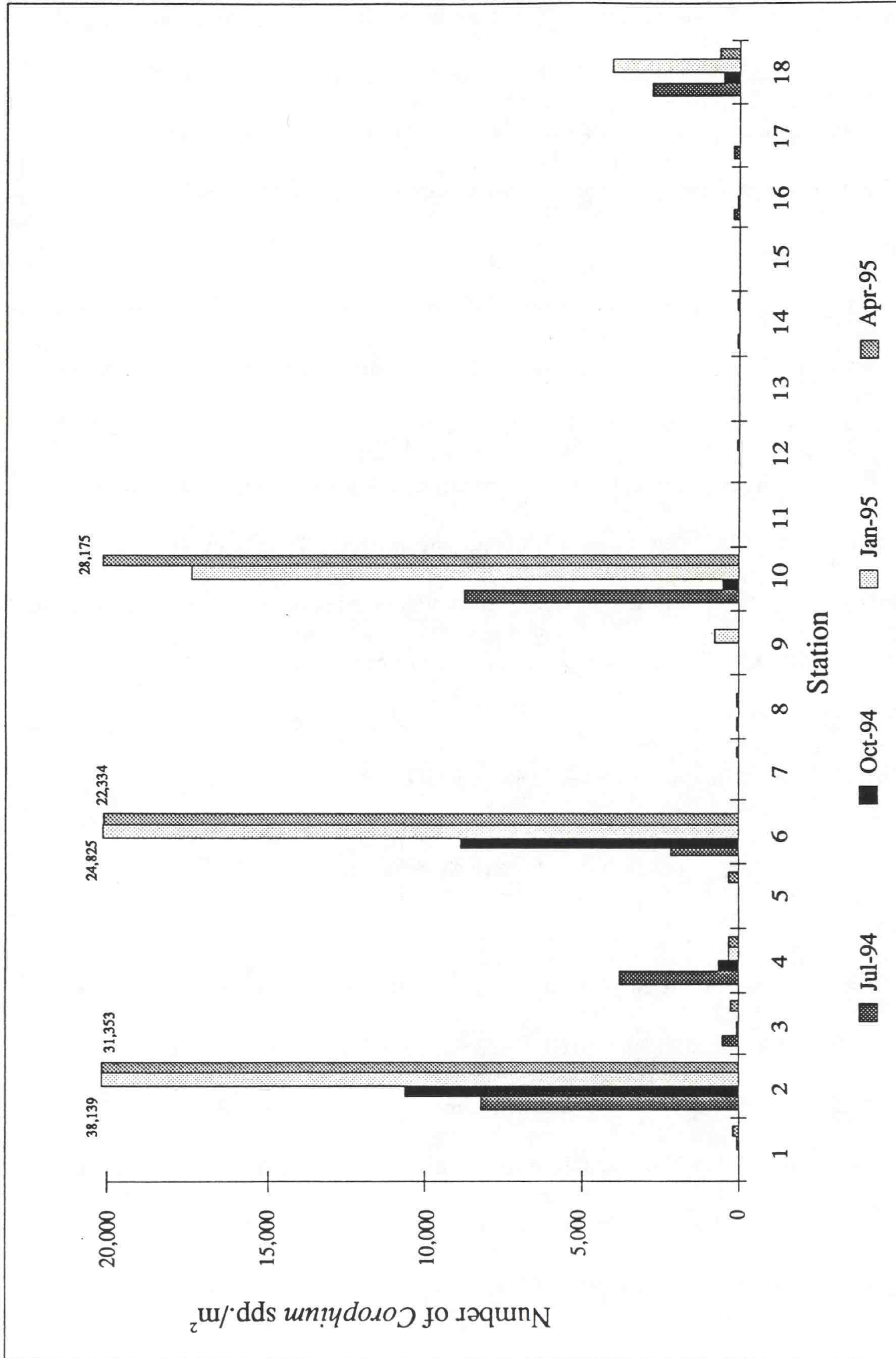

Figure 5. Number of *Corophium* spp./m<sup>2</sup> by station at Beach Nourishment Area O-44.0 in the lower Columbia River. Sampling was conducted in July and October 1994 and January and April 1995. Odd- and even-numbered stations were located about 15 and 30 m, respectively, from the high tide mark on the beach.

1.14 in April 1995 to 1.39 in January 1995, and mean E values ranged from 0.56 in April 1995 to 0.73 in January 1995 (Table 19). Diversity was significantly higher (ANOVA,  $P < 0.05$ ) at stations along the 30-m transect than at stations along the 15-m transect; however, E was not significantly different between transects.

### **Sediments**

Median grain size was not significantly different (ANOVA,  $P > 0.05$ ) between months or transects in Beach Nourishment Area O-44.0. Mean median grain size in the beach nourishment area ranged from 0.37 mm in October 1994 to 0.40 mm in January 1995 (Table 21). Percent silt/clay was not significantly different between months or transects (Kruskal-Wallis,  $P > 0.05$ ). Mean percent silt/clay ranged from 1.3% in July 1994 and April 1995 to 3.4% in October 1994 (Table 21). Percent volatile solids were significantly different between months (Kruskal-Wallis,  $P < 0.05$ ), but not significantly different between 15- and 30-m transects (Kruskal-Wallis,  $P > 0.05$ ). Mean percent volatile solids ranged from 0.4% in January 1995 to 0.6% in July and October 1994 (Table 21).

### **Beach Nourishment Area W-45.0**

#### **Benthic Invertebrates**

At Beach Nourishment Area W-45.0, benthic invertebrate densities (total) were not significantly different between months (ANOVA,  $P > 0.05$ ) (Table 22); the lowest mean density occurred in October 1994 (8,083 organisms/m<sup>2</sup>) and the highest in January 1995 (15,884 organisms/m<sup>2</sup>) (Table 23). Benthic invertebrate densities were significantly different between the 15- and 30-m transects ( $P < 0.05$ ), with the highest densities generally occurring at stations along the 30-m transects (Tables 22 and 23).

Table 21. Sediment characteristics at Beach Nourishment Area O-44.0 in the lower Columbia River, July 1994 through April 1995. In the "Area" column, the "O" refers to Oregon, and the succeeding number refers to the approximate location in river miles from the mouth of the river.

Area	Sta.	Median grain size (mm)				silt/clay (%)				volatile solids (%)			
		Jul	Oct	Jan	Apr	Jul	Oct	Jan	Apr	Jul	Oct	Jan	Apr
O-44.0	1	0.47	0.45	0.43	0.43	0.1	0.3	0.5	0.3	0.6	0.4	0.6	0.4
O-44.0	2	0.29	0.29	0.35	0.30	1.8	4.6	2.0	6.2	0.7	0.9	0.2	0.9
O-44.0	3	0.35	0.24	0.39	0.37	0.1	6.5	1.0	0.6	0.5	1.1	0.6	0.5
O-44.0	4	0.33	0.39	0.64	0.67	9.8	0.6	0.3	0.2	1.0	0.7	0.9	0.6
O-44.0	5	0.38	0.40	0.34	0.41	0.2	0.3	0.3	0.3	0.7	0.4	0.7	0.6
O-44.0	6	0.51	0.33	0.36	0.41	0.3	9.5	11.2	1.0	0.8	0.7	0.5	0.6
O-44.0	7	0.39	0.55	0.40	0.51	0.5	3.2	0.6	0.3	0.6	0.5	0.4	0.4
O-44.0	8	0.38	0.35	0.34	0.34	0.4	0.3	0.4	0.4	0.6	0.3	0.0	0.5
O-44.0	9	0.40	0.41	0.43	0.44	1.4	3.6	0.2	0.4	0.6	0.5	0.7	0.5
O-44.0	10	0.52	0.50	0.68	0.44	0.3	3.5	0.8	1.7	0.6	0.6	0.7	0.4
O-44.0	11	0.36	0.29	0.32	0.32	0.3	18.9	0.5	0.2	0.5	0.9	0.2	0.5
O-44.0	12	0.34	0.34	0.33	0.32	0.4	0.2	0.4	0.3	0.4	0.6	0.3	0.4
O-44.0	13	0.44	0.45	0.41	0.34	0.5	0.0	0.6	2.4	0.7	0.4	0.4	0.4
O-44.0	14	0.47	0.38	0.44	0.40	0.4	0.4	0.5	0.4	0.5	0.7	0.3	0.3
O-44.0	15	0.32	0.28	0.32	0.32	3.0	5.4	3.8	3.0	0.6	0.5	0.2	0.5
O-44.0	16	0.43	0.42	0.34	0.36	2.4	2.5	11.2	1.5	0.8	0.5	0.3	0.6
O-44.0	17	0.29	0.29	0.31	0.30	0.6	0.6	1.0	1.0	0.5	0.6	0.2	0.4
O-44.0	18	0.29	0.30	0.30	0.31	1.0	0.6	0.9	2.9	0.7	0.2	0.6	0.6
Mean		0.39	0.37	0.40	0.39	1.3	3.4	2.0	1.3	0.6	0.6	0.4	0.5

Table 22. Results of two-way analysis of variance for selected benthic invertebrate parameters measured at Beach Nourishment Area W-45.0 in the lower Columbia River, July and October 1994 and January and April 1995. Five stations were sampled along both the 15-m and 30-m transects in the beach nourishment area; these parallel transects were located about 15 and 30 m from the high tide mark on the beach. A significant difference ( $P \leq 0.05$ ) is indicated with an \*.

Parameter	Source	Degrees of freedom	F	P value
Benthic invertebrate density ( $\log_{10}(\text{value} + 1)$ ), total	Month	3	0.61	0.612
	Transect	1	21.20	0.000*
	Total	39		
<i>Corophium</i> spp. density ( $\log_{10}(\text{value} + 1)$ )	Month	3	0.30	0.829
	Transect	1	8.75	0.006*
	Total	39		
Diversity (H)	Month	3	3.30	0.033*
	Transect	1	1.24	0.274
	Total	39		
Equitability (E)	Month	3	1.78	0.170
	Transect	1	0.15	0.705
	Total	39		

Table 23. Benthic invertebrate densities (number/m<sup>2</sup>) at Beach Nourishment Area W-45.0 in the lower Columbia River, July 1994 through April 1995. In the "Area" column, the "W" refers to Washington, and the succeeding number refers to the approximate location in river miles from the mouth of the river. Generally, each density is the mean of 10 replicate samples collected at a station; the standard deviation (SD) is also shown for each density. Odd- and even-numbered stations were located about 15 and 30 m, respectively, from the high tide mark on the beach.

Area	Sta.	July		October		January		April	
		No./m <sup>2</sup>	SD	No./m <sup>2</sup>	SD	No./m <sup>2</sup>	SD	No./m <sup>2</sup>	SD
W-45.0	1	1,203	1,820	2,319	1,986	3,522	1,786	12,971	6,357
W-45.0	2	39,685	12,334	26,629	7,014	52,570	22,758	46,557	8,066
W-45.0	3	1,718	2,624	1,804	1,309	95	286	515	601
W-45.0	4	11,339	7,912	8,504	5,485	4,638	1,820	8,848	5,186
W-45.0	5	4,581	2,232	7,216	1,679	86	272	2,062	1,008
W-45.0	6	23,536	9,661	11,511	6,718	58,240	10,864	46,471	10,070
W-45.0	7	5,727	3,644	4,553	1,813	4,381	2,160	2,233	1,728
W-45.0	8	9,363	3,997	10,909	2,626	34,274	6,793	18,554	4,778
W-45.0	9	1,031	1,056	859	906	430	607	1,289	730
W-45.0	10	1,241	1,670	6,528	2,782	601	707	945	854
Mean		9,942		8,083		15,884		14,045	

The mean numbers of taxa/categories collected in the beach nourishment area were similar for each month, ranging from six to eight (Table 24). Major benthic invertebrate taxa collected in the beach nourishment area included nemerteans, oligochaetes, *Fluminicola virens*, *Corbicula fluminea*, and *Corophium salmonis* (Table 25).

Densities of *Corophium* spp. were not significantly different (ANOVA,  $P > 0.05$ ) between months in Beach Nourishment Area W-45.0; however, densities were significantly higher ( $P < 0.05$ ) at stations along the 30-m transect than at stations along the 15-m transect (Tables 22 and 25). Mean densities of *Corophium* spp. at stations along the 15-m transect ranged from 245 organisms/m<sup>2</sup> in January 1995 to 2,285 organisms/m<sup>2</sup> in April 1995. At stations along the 30-m transect, mean densities of *Corophium* spp. ranged from 4,945 organisms/m<sup>2</sup> in July 1994 to 23,347 organism/m<sup>2</sup> in January 1995 (Table 25). Densities of *Corophium* spp. also varied spatially along each transect (Fig. 6).

Diversity (H) was significantly different (ANOVA,  $P < 0.05$ ) between months, but not significantly different (ANOVA,  $P > 0.05$ ) between transects in Beach Nourishment Area W-45.0 (Table 22). Mean H values ranged from 1.28 in January 1995 to 2.15 in July 1994 (Table 24). Equitability (E) was not significantly different (ANOVA,  $P > 0.05$ ) between months or transects (Table 22). Mean E values ranged from 0.53 in January 1995 to 0.78 in July 1994 (Table 24).

### Sediments

Median grain size was not significantly different (ANOVA,  $P > 0.05$ ) between months in Beach Nourishment Area W-45.0; however, it was significantly higher ( $P < 0.05$ ) at stations along the 15-m transect (mean = 0.40 mm) than at stations along the 30-m transect (mean = 0.29 mm) (Table 26). The high outlying value for Station 5 in July 1994 was

Table 24. Numbers of taxa/categories, Diversities (H), and Equitabilities (E) at Beach Nourishment Area W-45.0 in the lower Columbia River, July 1994 through April 1995. In the "Area" column, the "W" refers to Washington, and the succeeding number refers to the approximate location in river miles from the mouth of the river. Odd- and even-numbered stations were located about 15 and 30 m, respectively, from the high tide mark on the beach.

Area	Sta.	July			October			January			April		
		No. taxa	H	E	No. taxa	H	E	No. taxa	H	E	No. taxa	H	E
W-45.0	1	5	2.16	0.93	7	2.16	0.77	7	2.59	0.92	8	1.41	0.47
W-45.0	2	15	2.53	0.65	13	1.93	0.52	11	0.94	0.27	10	0.73	0.22
W-45.0	3	4	1.53	0.77	4	1.55	0.77	1	0.00	0.00	3	1.46	0.92
W-45.0	4	7	1.85	0.66	7	2.27	0.81	5	2.17	0.93	8	2.45	0.82
W-45.0	5	7	2.15	0.77	5	1.33	0.57	1	0.00	0.00	6	1.83	0.71
W-45.0	6	14	2.94	0.77	8	2.27	0.76	11	1.43	0.41	12	1.28	0.36
W-45.0	7	10	2.81	0.85	6	1.89	0.73	6	2.02	0.78	6	2.44	0.94
W-45.0	8	10	2.33	0.70	7	2.28	0.81	10	1.52	0.46	8	1.41	0.47
W-45.0	9	3	1.46	0.92	3	0.92	0.58	3	1.52	0.96	1	0.00	0.00
W-45.0	10	5	1.70	0.73	5	2.00	0.86	2	0.59	0.59	3	1.44	0.91
Mean		8	2.15	0.78	7	1.86	0.72	6	1.28	0.53	6	1.44	0.58



Table 25. Mean densities (number/m<sup>2</sup>) and standard deviations (SD) of benthic invertebrates collected at Beach Nourishment Area W-45.0 in the lower Columbia River, July 1994 through April 1995. Five stations were sampled along both the 15-m and 30-m transects in the beach nourishment area; these parallel transects were located about 15 and 30 m from the high tide mark on the beach. Each density represents the mean of all samples collected along a particular transect. Any addition discrepancies in totals are due to rounding.

Taxon	July		October		January		April	
	No./m <sup>2</sup>	SD	No./m <sup>2</sup>	SD	No./m <sup>2</sup>	SD	No./m <sup>2</sup>	SD
<b>BEACH NOURISHMENT AREA (15-m)</b>								
Nemertea	179	662	155	333	631	1,286	240	650
Nematomorpha	18	124	0	0	0	0	0	0
Turbellaria	0	0	52	206	105	334	275	504
Oligochaeta	698	1,013	309	620	105	284	275	660
Fluminicola virens	197	509	0	0	333	652	189	469
Corbicula fluminea	734	1,202	1,907	2,170	280	508	498	651
Ostracoda	18	124	52	206	0	0	17	122
Corophium spp.	72	298	0	0	0	0	0	0
Corophium salmonis	286	738	515	868	245	464	2,285	4,821
Chironomidae larvae	90	265	0	0	0	0	0	0
Chironomidae pupae	36	174	0	0	0	0	0	0
Ceratopogonidae larvae	358	1,213	344	776	35	172	34	170
Collembola adult	72	298	0	0	0	0	0	0
Hydracarina	0	0	17	122	0	0	0	0
Total	2,756	2,996	3,350	2,762	1,736	2,262	3,814	5,486

Table 25. Continued.

Taxon	July		October		January		April	
	No./m <sup>2</sup>	SD	No./m <sup>2</sup>	SD	No./m <sup>2</sup>	SD	No./m <sup>2</sup>	SD
<b>BEACH NOURISHMENT AREA (30-m)</b>								
Nemertea	596		1,580	2,292	825	981	670	1,243
Nematomorpha	368		0	0	0	0	0	0
Turbellaria	18		34	170	258	528	258	498
Polychaeta	53		0	0	0	0	0	0
Neanthes limnicola	0		17	122	0	0	17	122
Oligochaeta	6,539		2,182	2,169	3,127	3,364	1,907	2,413
Gastropoda	35		17	122	17	122	0	0
Juga plicifera	0		17	122	0	0	0	0
Fluminicola virens	1,665		601	1,380	447	678	361	674
Corbicula fluminea	508		2,148	1,649	996	1,207	670	890
Pisidium spp.	53		120	425	69	340	17	122
Ostracoda	473		0	0	137	438	103	282
Corophium spp.	877		0	0	0	0	0	0
Corophium salmonis	4,050		5,257	6,038	22,677	22,115	18,949	18,382
Corophium spinicorne	18		0	0	670	1,088	670	1,486
Pontoporeia hoyi	0		0	0	0	0	17	122
Harpacticoida	18		0	0	17	122	17	122
Diptera pupae	18		0	0	0	0	0	0
Chironomidae larvae	1,490		86	313	137	471	120	348
Chironomidae pupae	105		0	0	0	0	0	0
Ceratopogonidae larvae	386		670	1,155	653	1,049	481	798
Trichoptera larvae	18		17	122	0	0	0	0
Ephemeroptera nymph	0		34	170	34	170	0	0
Coleoptera larvae	53		0	0	0	0	0	0
Hydracarina	18		34	170	0	0	17	122
Total	17,355	15,576	12,816	8,799	30,065	26,534	24,275	20,200

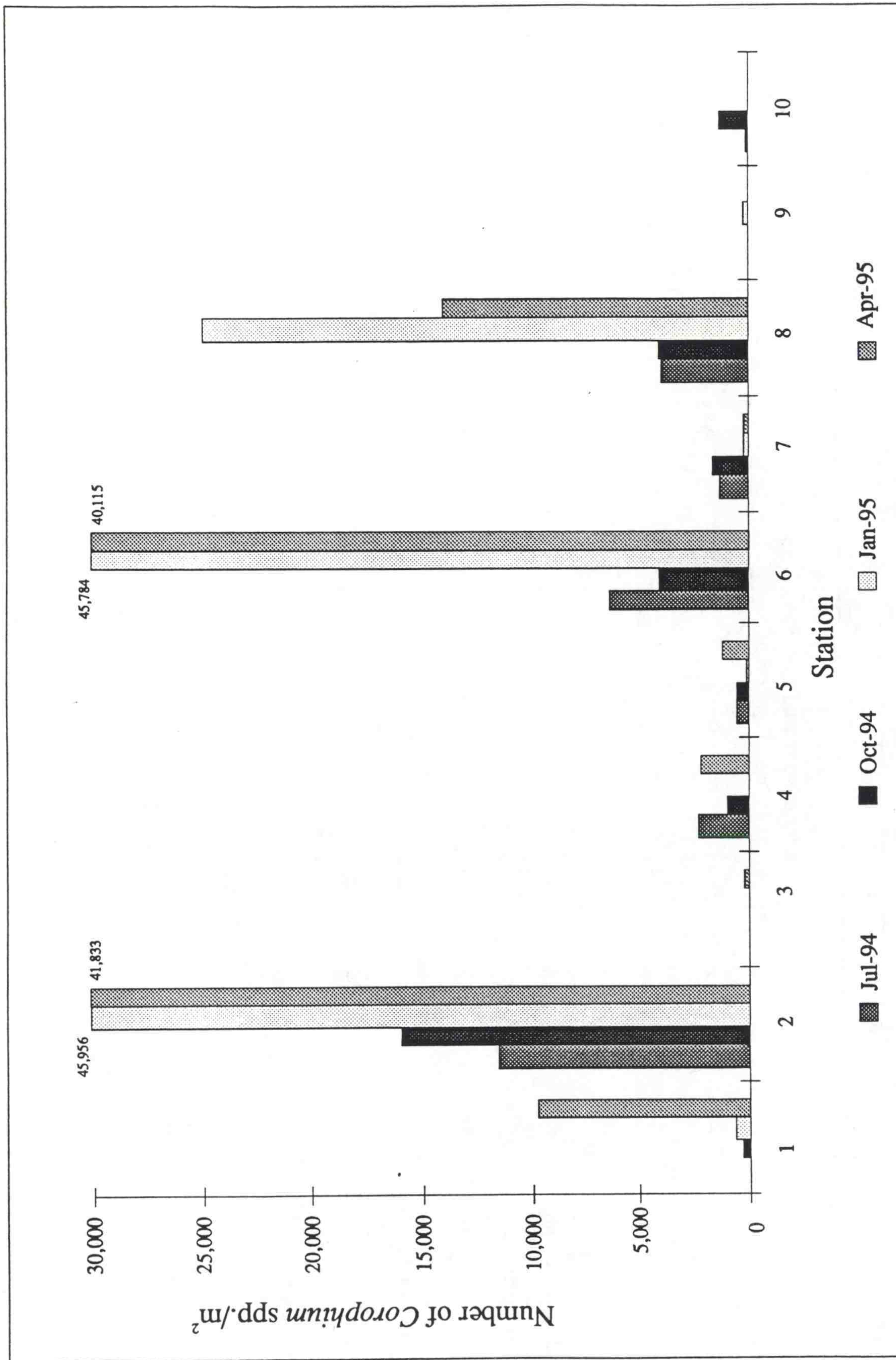

Figure 6. Number of *Corophium* spp./m<sup>2</sup> by station at Beach Nourishment Area W-45.0 in the lower Columbia River. Sampling was conducted in July and October 1994 and January and April 1995. Odd- and even-numbered stations were located about 15 and 30 m, respectively, from the high tide mark on the beach.

Table 26. Sediment characteristics at Beach Nourishment Area W-45.0 in the lower Columbia River, July 1994 through April 1995. In the "Area" column, the "W" refers to Washington, and the succeeding number refers to the approximate location in river miles from the mouth of the river.

Area	Sta.	Median grain size (mm)				silt/clay (%)				Volatile solids (%)			
		Jul	Oct	Jan	Apr	Jul	Oct	Jan	Apr	Jul	Oct	Jan	Apr
W-45.0	1	0.72	0.57	0.47	0.37	0.6	4.0	1.0	1.4	0.6	0.7	0.6	0.5
W-45.0	2	0.06	0.09	0.07	0.06	52.3	42.1	44.0	54.9	1.2	0.9	1.4	1.4
W-45.0	3	0.50	0.46	0.39	0.40	0.4	0.3	0.6	0.4	0.6	0.5	0.7	0.6
W-45.0	4	0.44	0.38	0.36	0.33	0.3	0.3	0.6	5.0	0.7	0.5	0.5	0.5
W-45.0	5	16.20	0.35	0.37	0.36	0.3	8.7	0.2	0.3	0.7	0.7	0.0	0.4
W-45.0	6	0.11	0.40	0.36	0.28	43.1	4.4	2.0	24.3	1.0	0.8	0.7	1.1
W-45.0	7	0.33	0.27	0.36	0.47	0.5	5.6	0.5	1.7	7.8	0.5	0.6	0.6
W-45.0	8	0.37	0.35	0.37	0.31	0.8	0.6	2.0	1.0	0.6	0.7	0.5	0.9
W-45.0	9	0.29	0.31	0.30	0.30	1.3	4.6	1.5	1.9	0.7	0.3	0.2	0.6
W-45.0	10	0.35	0.40	0.31	0.33	0.8	1.1	1.3	0.9	3.0	0.7	0.5	0.3
Mean		1.94	0.36	0.34	0.32	10.0	7.2	5.4	9.2	1.7	0.6	0.6	0.7

excluded from the statistical analysis. Mean median grain size in the beach nourishment area ranged from 0.32 mm in April 1995 to 1.94 mm (or 0.35 mm if the outlying value is excluded) in July 1994 (Table 26). Percent silt/clay was not significantly different between months (Kruskal-Wallis,  $P > 0.05$ ), but was significantly lower at stations along the 15-m transect (Kruskal-Wallis,  $P < 0.05$ ) than at stations along the 30-m transect. Mean percent silt/clay ranged from 5.4% in January 1995 to 10.0% in July 1994 (Table 26). Percent volatile solids were not significantly different between months (Kruskal-Wallis,  $P > 0.05$ ), but were significantly different between transects (Kruskal-Wallis,  $P < 0.05$ ). Mean percent volatile solids ranged from 0.6% in October 1994 and January 1995 to 1.7% in July 1994 (Table 26).

#### Beach Nourishment Area O-45.1

##### Benthic Invertebrates

At Beach Nourishment Area O-45.1, benthic invertebrate densities (total) were not significantly different between months or transects (ANOVA,  $P > 0.05$ ) (Table 27); the lowest mean density occurred in October 1994 (1,647 organisms/m<sup>2</sup>) and the highest in April 1995 (7,838 organisms/m<sup>2</sup>) (Table 28).

The mean numbers of taxa/categories collected in the beach nourishment area ranged from three to five (Table 29). Major benthic invertebrate taxa collected in the beach nourishment area included oligochaetes, *Corbicula fluminea*, *Corophium salmonis*, and *Corophium spinicorne* (Table 30).

Densities of *Corophium* spp. were not significantly different (ANOVA,  $P > 0.05$ ) between months or transects in Beach Nourishment Area O-45.1 (Table 27). Mean densities

Table 27. Results of two-way analysis of variance for selected benthic invertebrate parameters measured at Beach Nourishment Area O-45.1 in the lower Columbia River, July and October 1994 and January and April 1995. Two stations were sampled along both the 15-m and 30-m transects in the beach nourishment area; these parallel transects were located about 15 and 30 m from the high tide mark on the beach. A significant difference ( $P \leq 0.05$ ) is indicated with an \*.

Parameter	Source	Degrees of freedom	F	P value
Benthic invertebrate density ( $\log_{10}(\text{value} + 1)$ ), total	Month	3	0.09	0.966
	Transect	1	2.13	0.183
	Total	15		
<i>Corophium</i> spp. density ( $\log_{10}(\text{value} + 1)$ )	Month	3	0.28	0.837
	Transect	1	1.26	0.295
	Total	15		
Diversity (H)	Month	3	0.90	0.483
	Transect	1	1.32	0.284
	Total	15		
Equitability (E)	Month	3	0.31	0.817
	Transect	1	1.40	0.271
	Total	15		

Table 28. Benthic invertebrate densities (number/m<sup>2</sup>) at Beach Nourishment Area O-45.1 in the lower Columbia River, July 1994 through April 1995. In the "Area" column, the "O" refers to Oregon, and the succeeding number refers to the approximate location in river miles from the mouth of the river. Generally, each density is the mean of 10 replicate samples collected at a station; the standard deviation (SD) is also shown for each density. Odd- and even-numbered stations were located about 15 and 30 m, respectively, from the high tide mark on the beach.

Area	Sta.	July		October		January		April	
		No./m <sup>2</sup>	SD	No./m <sup>2</sup>	SD	No./m <sup>2</sup>	SD	No./m <sup>2</sup>	SD
O-45.1	1	172	543	172	362	430	607	258	415
O-45.1	2	172	362	344	830	687	887	172	362
O-45.1	3	2,062	1,087	573	960	773	854	344	444
O-45.1	4	10,566	4,111	5,498	3,465	15,032	22,982	30,580	13,703
Mean		3,243		1,647		4,230		7,838	

Table 29. Numbers of taxa/categories, Diversities (H), and Equitabilities (E) at Beach Nourishment Area O-45.1 in the lower Columbia River, July 1994 through April 1995. In the "Area" column, the "O" refers to Oregon, and the succeeding number refers to the approximate location in river miles from the mouth of the river. Odd- and even-numbered stations were located about 15 and 30 m, respectively, from the high tide mark on the beach.

Area	Sta.	July			October			January			April		
		No. taxa	H	E	No. taxa	H	E	No. taxa	H	E	No. taxa	H	E
O-45.1	1	2	1.00	1.00	1	0.00	0.00	3	1.37	0.86	2	0.92	0.92
O-45.1	2	2	1.00	1.00	2	1.00	1.00	3	1.50	0.95	1	0.00	0.00
O-45.1	3	6	1.73	0.67	3	1.46	0.92	5	2.20	0.95	3	1.50	0.95
O-45.1	4	5	0.89	0.38	5	1.49	0.64	8	0.78	0.26	6	0.89	0.34
Mean		4	1.16	0.76	3	0.99	0.64	5	1.46	0.76	3	0.83	0.55



Table 30. Mean densities (number/m<sup>2</sup>) and standard deviations (SD) of benthic invertebrates collected at Beach Nourishment Area O-45.1 in the lower Columbia River, July 1994 through April 1995. Two stations were sampled along both the 15-m and 30-m transects in the beach nourishment area; these parallel transects were located about 15 and 30 m from the high tide mark on the beach. Each density represents the mean of all samples collected along a particular transect. Any addition discrepancies in totals are due to rounding.

Taxon	July		October		January		April	
	No./m <sup>2</sup>	SD	No./m <sup>2</sup>	SD	No./m <sup>2</sup>	SD	No./m <sup>2</sup>	SD
<b>BEACH NOURISHMENT AREA (15-m)</b>								
Nemertea	0		90	271	86	264	86	264
Nematomorpha	43	192	0	0	0	0	0	0
Turbellaria	0		0	0	129	420	0	0
Oligochaeta	86	264	136	322	43	192	43	192
Fluminicola virens	0		0	0	0	0	43	192
Corbicula fluminea	43	192	0	0	215	472	86	264
Corophium salmonis	687	817	136	431	43	192	0	0
Chironomidae larvae	43	192	0	0	0	0	0	0
Ceratopogonidae larvae	215	473	0	0	43	192	43	192
Collembola adult	0		0	0	43	192	0	0
Total	1,117	1,280	362	720	601	743	301	420
<b>BEACH NOURISHMENT AREA (30-m)</b>								
Nemertea	0		0	0	43	192	0	0
Neanthes limnicola	86	384	0	0	43	192	43	192
Oligochaeta	172	449	386	762	129	315	472	902
Gastropoda	0		43	192	0	0	0	0
Corbicula fluminea	472	709	816	1,350	301	504	215	382
Corophium salmonis	4,467	5,196	1,632	2,538	6,700	15,312	12,885	15,328
Corophium spinicorne	129	315	43	192	472	1,379	1,374	2,483
Chironomidae larvae	0		0	0	129	420	386	590
Ceratopogonidae larvae	43	192	0	0	0	0	0	0
Hydracarina	0		0	0	43	192	0	0
Total	5,369	6,041	2,921	3,606	7,860	17,456	15,376	18,230

of *Corophium* spp. at stations along the 15-m transect ranged from 0 organisms/m<sup>2</sup> in April 1995 to 687 organisms/m<sup>2</sup> in July 1994. At stations along the 30-m transect, mean densities of *Corophium* spp. ranged from 1,675 organisms/m<sup>2</sup> in October 1994 to 14,259 organisms/m<sup>2</sup> in April 1995 (Table 30). Densities of *Corophium* spp. also varied spatially along each transect (Fig. 7).

Diversity (H) and Equitability (E) were not significantly different (ANOVA,  $P > 0.05$ ) between months or transects in Beach Nourishment Area O-45.1 (Table 27). Mean H values ranged from 0.83 in April 1995 to 1.46 in January 1995, and mean E values ranged from 0.55 in April 1995 to 0.76 in July 1994 and January 1995 (Table 29).

### Sediments

Median grain size was not significantly different (ANOVA,  $P > 0.05$ ) between months or transects in Beach Nourishment Area O-45.1. Mean median grain size in the beach nourishment area ranged from 0.23 mm in July 1994 and April 1995 to 0.24 mm in October 1994 and January 1995 (Table 31). Percent silt/clay was not significantly different between months or transects (Kruskal-Wallis,  $P > 0.05$ ). Mean percent silt/clay ranged from 22.8% in April 1995 to 24.8% in July 1994 (Table 31). Percent volatile solids were not significantly different between months (Kruskal-Wallis,  $P > 0.05$ ), but were significantly lower (Kruskal-Wallis,  $P < 0.05$ ) at stations along the 15-m transect than at stations along the 30-m transect. Mean percent volatile solids ranged from 1.0% in July 1994 to 1.4% in October 1994 (Table 31).

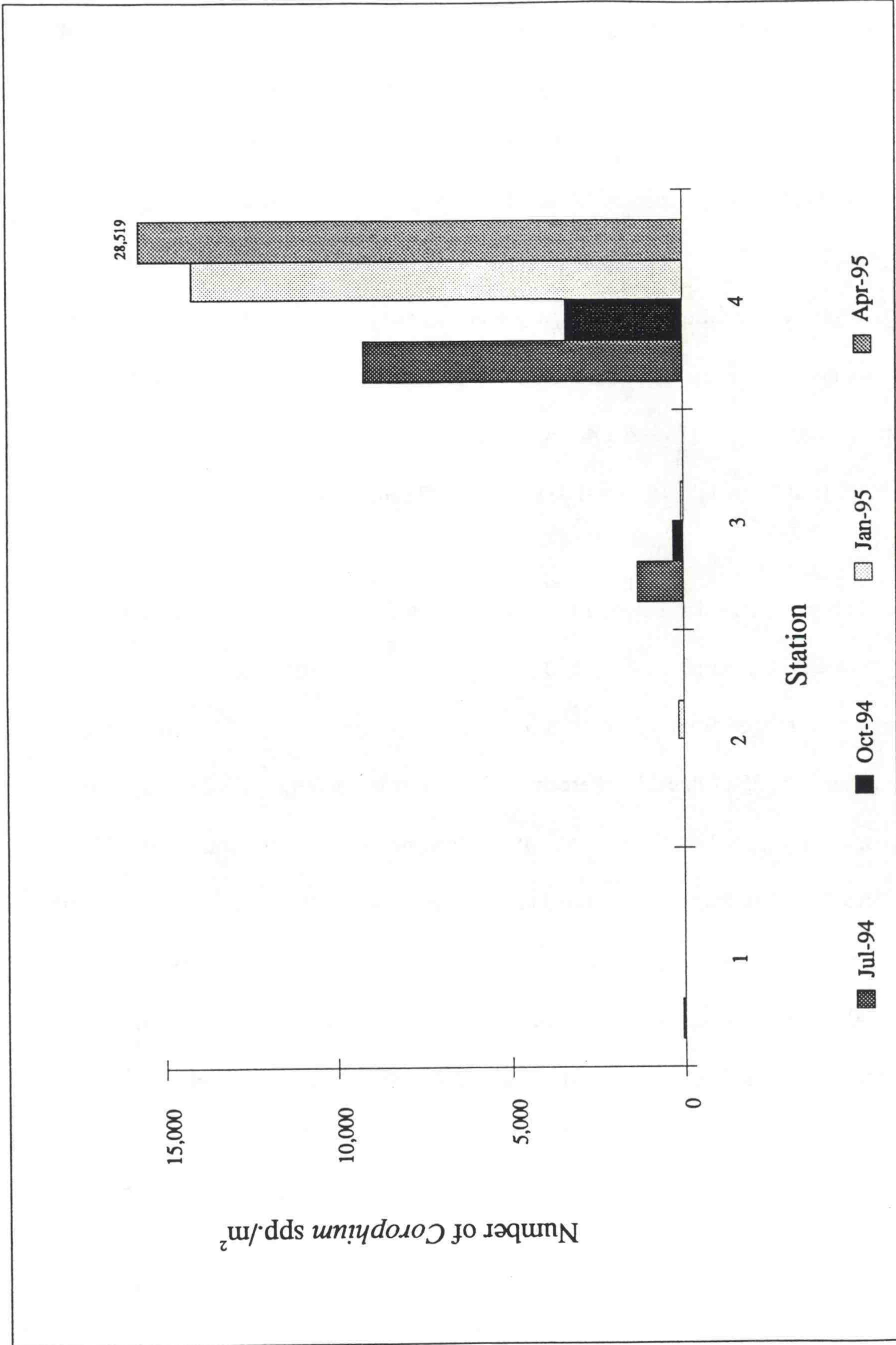

Figure 7. Number of *Corophium* spp./m<sup>2</sup> by station at Beach Nourishment Area O-45.1 in the lower Columbia River. Sampling was conducted in July and October 1994 and January and April 1995. Odd- and even-numbered stations were located about 15 and 30 m, respectively, from the high tide mark on the beach.

Table 31. Sediment characteristics at Beach Nourishment Area O-45.1 in the lower Columbia River, July 1994 through April 1995. In the "Area" column, the "O" refers to Oregon, and the succeeding number refers to the approximate location in river miles from the mouth of the river.

Area	Sta.	Median grain size (mm)				silt/clay (%)				volatile solids (%)			
		Jul	Oct	Jan	Apr	Jul	Oct	Jan	Apr	Jul	Oct	Jan	Apr
O-45.1	1	0.28	0.28	0.27	0.28	0.6	0.6	0.5	0.8	0.7	0.0	0.5	0.4
O-45.1	2	0.39	0.28	0.29	0.26	0.3	0.7	0.6	0.6	0.8	0.6	0.3	0.6
O-45.1	3	0.25	0.40	0.39	0.37	0.8	0.3	0.2	0.7	0.6	0.4	0.0	0.1
O-45.1	4	0.01	0.01	0.01	0.01	97.3	96.0	95.1	89.1	1.7	4.4	4.1	3.2
Mean		0.23	0.24	0.24	0.23	24.8	24.4	24.1	22.8	1.0	1.4	1.2	1.1

## Beach Nourishment Area O-47.8

### Benthic Invertebrates

At Beach Nourishment Area O-47.8, benthic invertebrate densities (total) were significantly different between months and transects (ANOVA,  $P < 0.05$ ) (Table 32); the lowest mean density occurred in October 1994 (1,306 organisms/m<sup>2</sup>) and the highest in April 1995 (12,613 organisms/m<sup>2</sup>) (Table 33). In all months, higher densities occurred at stations along the 30-m transect than those along the 15-m transect.

The mean numbers of taxa/categories (by month) collected in the beach nourishment area ranged from two to five (Table 34). Major benthic invertebrate taxa collected in the beach nourishment area included oligochaetes, *Corbicula fluminea*, *Corophium salmonis*, and Ceratopogonidae larvae (Table 35).

Densities of *Corophium* spp. were not significantly different (ANOVA,  $P > 0.05$ ) between months in Beach Nourishment Area O-47.8; however, densities were significantly higher ( $P < 0.05$ ) at stations along the 30-m transect compared to stations along the 15-m transect (Tables 32 and 35). Mean densities of *Corophium* spp. at stations along the 15-m transect ranged from 0 organisms/m<sup>2</sup> in July and October 1994 to 286 organisms/m<sup>2</sup> in January 1995. At stations along the 30-m transect, mean densities of *Corophium* spp. ranged from 487 organisms/m<sup>2</sup> in July 1994 to 19,413 organisms/m<sup>2</sup> in April 1995 (Table 35). Densities of *Corophium* spp. also varied spatially along each transect (Fig. 8).

Diversity (H) and Equitability (E) were not significantly different (ANOVA,  $P > 0.05$ ) between months (Table 32). Mean H values ranged from 0.73 in October 1994 to 1.20 in April 1995, and mean E values ranged from 0.45 in July 1994 to 0.67 in April 1995 (Table 34). Diversity was significantly higher (ANOVA,  $P < 0.05$ ) at stations along the 30-m

Table 32. Results of two-way analysis of variance for selected benthic invertebrate parameters measured at Beach Nourishment Area O-47.8 in the lower Columbia River, July and October 1994 and January and April 1995. Three stations were sampled along both the 15-m and 30-m transects in the beach nourishment area; these parallel transects were located about 15 and 30 m from the high tide mark on the beach. A significant difference ( $P \leq 0.05$ ) is indicated with an \*.

Parameter	Source	Degrees of freedom	F	P value
Benthic invertebrate density ( $\log_{10}(\text{value} + 1)$ ), total	Month	3	5.84	0.007*
	Transect	1	22.99	0.000*
	Total	23		
<i>Corophium</i> spp. density ( $\log_{10}(\text{value} + 1)$ )	Month	3	3.09	0.057
	Transect	1	34.97	0.000*
	Total	23		
Diversity (H)	Month	3	1.07	0.389
	Transect	1	22.08	0.000*
	Total	23		
Equitability (E)	Month	3	0.52	0.672
	Transect	1	1.43	0.249
	Total	23		

Table 33. Benthic invertebrate densities (number/m<sup>2</sup>) at Beach Nourishment Area O-47.8 in the lower Columbia River, July 1994 through April 1995. In the "Area" column, the "O" refers to Oregon, and the succeeding number refers to the approximate location in river miles from the mouth of the river. Generally, each density is the mean of 10 replicate samples collected at a station; the standard deviation (SD) is also shown for each density. Odd- and even-numbered stations were located about 15 and 30 m, respectively, from the high tide mark on the beach.

Area	Sta.	July		October		January		April	
		No./m <sup>2</sup>	SD	No./m <sup>2</sup>	SD	No./m <sup>2</sup>	SD	No./m <sup>2</sup>	SD
O-47.8	1	573	859	86	272	1,031	1,131	344	601
O-47.8	2	2,663	2,002	2,577	1,670	24,309	9,208	60,559	11,238
O-47.8	3	687	1,131	0	0	1,374	1,293	4,209	1,919
O-47.8	4	1,203	1,087	3,436	1,765	5,412	4,030	6,271	2,397
O-47.8	5	430	730	191	379	1,890	1,391	1,460	1,218
O-47.8	6	5,583	2,983	1,546	3,407	9,449	9,269	2,835	1,767
Mean		1,856		1,306		7,244		12,613	

Table 34. Numbers of taxa/categories, Diversities (H), and Equitabilities (E) at Beach Nourishment Area O-47.8 in the lower Columbia River, July 1994 through April 1995. In the "Area" column, the "O" refers to Oregon, and the succeeding number refers to the approximate location in river miles from the mouth of the river. Odd- and even-numbered stations were located about 15 and 30 m, respectively, from the high tide mark on the beach.

Area	Sta.	July			October			January			April		
		No. taxa	H	E	No. taxa	H	E	No. taxa	H	E	No. taxa	H	E
O-47.8	1	1	0.00	0.00	1	0.00	0.00	2	0.65	0.65	2	0.81	0.81
O-47.8	2	5	1.69	0.73	2	0.92	0.92	6	0.58	0.22	10	1.03	0.31
O-47.8	3	1	0.00	0.00	0	0.00	0.00	3	0.87	0.55	2	0.69	0.69
O-47.8	4	5	2.18	0.94	5	1.15	0.50	6	1.89	0.73	7	1.92	0.68
O-47.8	5	2	0.72	0.72	2	1.00	1.00	3	0.53	0.33	2	0.79	0.79
O-47.8	6	6	0.80	0.31	4	1.28	0.64	6	1.75	0.68	6	1.97	0.76
Mean		3	0.90	0.45	2	0.73	0.51	4	1.04	0.53	5	1.20	0.67



Table 35. Mean densities (number/m<sup>2</sup>) and standard deviations (SD) of benthic invertebrates collected at Beach Nourishment Area O-47.8 in the lower Columbia River, July 1994 through April 1995. Three stations were sampled along both the 15-m and 30-m transects in the beach nourishment area; these parallel transects were located about 15 and 30 m from the high tide mark on the beach. Each density represents the mean of all samples collected along a particular transect. Any addition discrepancies in totals are due to rounding.

Taxon	July		October		January		April	
	No./m <sup>2</sup>	SD	No./m <sup>2</sup>	SD	No./m <sup>2</sup>	SD	No./m <sup>2</sup>	SD
<b>BEACH NOURISHMENT AREA (15-m)</b>								
Nemertea	0	0	0	0	86	262	0	0
Turbellaria	0	0	0	0	86	262	458	739
Oligochaeta	533	901	30	160	945	1,222	1,518	1,828
Corbicula fluminea	30	160	59	222	29	157	0	0
Corophium salmonis	0	0	0	0	286	725	29	157
Total	563	897	89	266	1,432	1,283	2,004	2,108
<b>BEACH NOURISHMENT AREA (30-m)</b>								
Nemertea	115	297	86	262	773	992	143	326
Turbellaria	0	0	29	157	86	346	200	583
Neanthes limnicola	29	157	0	0	0	0	0	0
Oligochaeta	1,775	2,835	0	0	200	433	916	1,478
Fluminicola virens	0	0	0	0	29	157	0	0
Corbicula fluminea	458	773	258	512	458	739	1,088	1,234
Corophium salmonis	487	834	630	1,333	8,676	10,829	18,497	24,170
Corophium spinicorne	0	0	0	0	114	373	916	1,171
Pontoporeia hoyi	0	0	0	0	0	0	57	314
Chironomidae larvae	57	218	0	0	0	0	258	400
Chironomidae pupae	29	157	0	0	0	0	0	0
Ceratopogonidae larvae	200	370	1,518	2,297	2,692	4,577	1,002	1,011
Ephemeroptera nymph	0	0	0	0	29	157	86	346
Hydracarina	0	0	0	0	0	0	57	314
Total	3,150	2,793	2,520	2,460	13,057	11,239	23,221	27,660

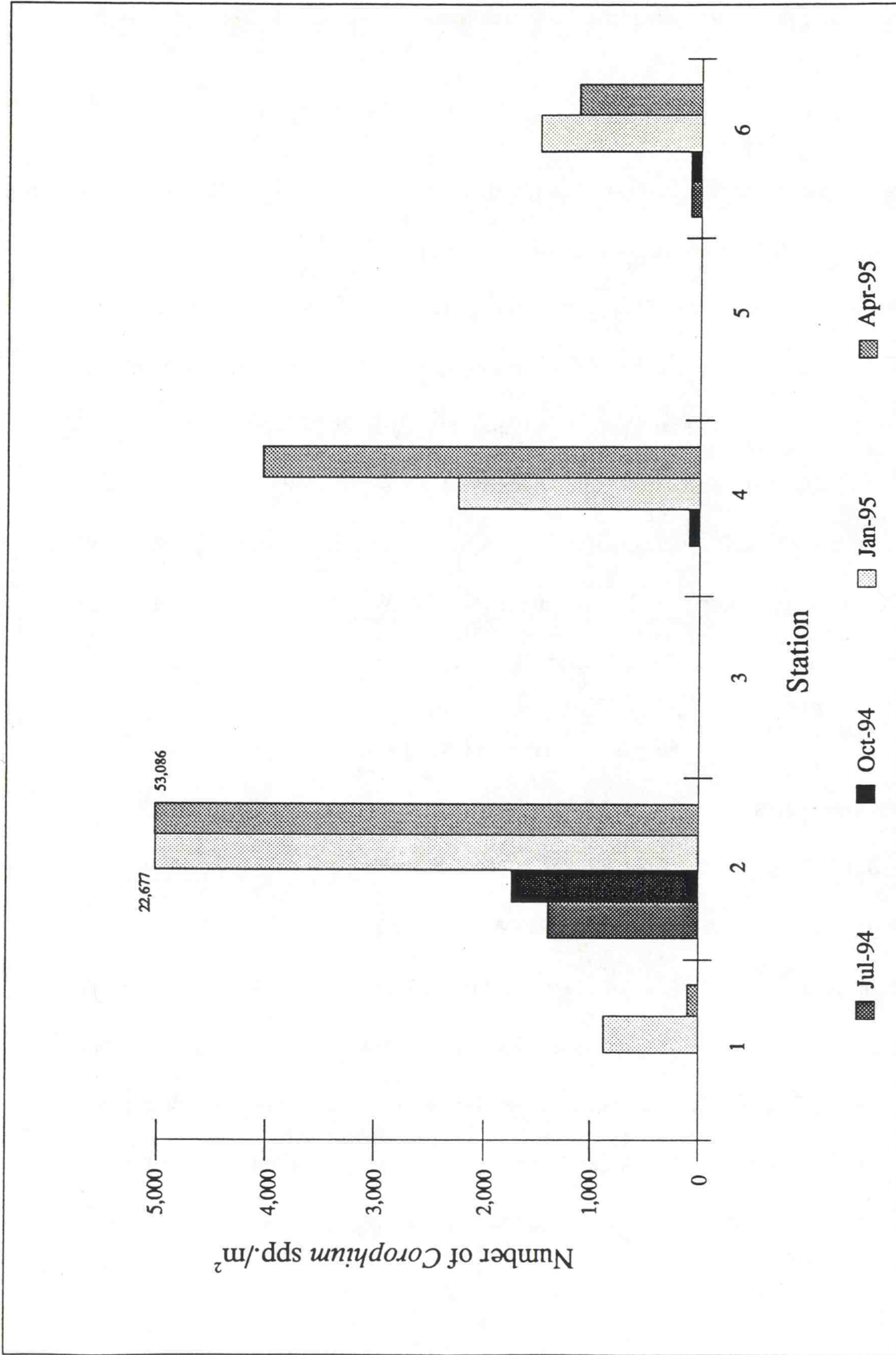

Figure 8. Number of *Corophium* spp./m<sup>2</sup> by station at Beach Nourishment Area O-47.8 in the lower Columbia River. Sampling was conducted in July and October 1994 and January and April 1995. Odd- and even-numbered stations were located about 15 and 30 m, respectively, from the high tide mark on the beach.

transect compared to stations along the 15-m transect; however, E was not significantly different between transects.

### **Sediments**

Median grain size was not significantly different (ANOVA,  $P > 0.05$ ) between months or transects in Beach Nourishment Area O-47.8. Mean median grain size in the beach nourishment area ranged from 0.32 mm in October 1994 to 0.58 mm in April 1995 (Table 36). Percent silt/clay was not significantly different between months or transects (Kruskal-Wallis,  $P > 0.05$ ). Mean percent silt/clay ranged from 0.3% in April 1995 to 2.7% in July 1994 (Table 36). Percent volatile solids were not significantly different between months (Kruskal-Wallis,  $P > 0.05$ ), but were significantly higher at stations along the 30-m transect than at stations along the 15-m transect (Kruskal-Wallis,  $P < 0.05$ ). Mean percent volatile solids ranged from 0.3% in January 1995 to 1.1% in July 1994 (Table 36).

### **Beach Nourishment Area O-57.0**

#### **Benthic Invertebrates**

At Beach Nourishment Area O-57.0, benthic invertebrate densities (total) were not significantly different between months (ANOVA,  $P > 0.05$ ) (Table 37); the lowest mean density occurred in October 1994 (14,041 organisms/m<sup>2</sup>) and the highest in July 1994 (22,065 organisms/m<sup>2</sup>) (Table 38). Benthic invertebrate densities were significantly different between the 15- and 30-m transects ( $P < 0.05$ ), with the highest densities generally occurring at stations along the 30-m transect (Tables 37 and 38). In the undisturbed area outside of the beach nourishment area (Stations 1 and 2), mean benthic invertebrate densities were lower

Table 36. Sediment characteristics at Beach Nourishment Area O-47.8 in the lower Columbia River, July 1994 through April 1995. In the "Area" column, the "O" refers to Oregon, and the succeeding number refers to the approximate location in river miles from the mouth of the river.

Area	Sta.	Median grain size (mm)				silt/clay (%)				Volatile solids (%)			
		Jul	Oct	Jan	Apr	Jul	Oct	Jan	Apr	Jul	Oct	Jan	Apr
O-47.8	1	0.40	0.24	0.23	0.43	0.1	2.9	0.4	0.1	0.7	0.5	0.2	0.4
O-47.8	2	0.16	0.16	0.22	1.45	15.2	10.9	1.3	0.7	3.6	0.8	0.6	0.3
O-47.8	3	0.38	0.36	0.41	0.44	0.3	0.0	0.0	0.4	0.2	0.2	0.2	0.3
O-47.8	4	0.45	0.40	0.73	0.38	0.1	0.4	0.4	0.1	0.6	0.5	0.3	0.3
O-47.8	5	0.41	0.39	0.36	0.45	0.2	0.5	0.5	0.3	0.6	0.4	0.4	0.3
O-47.8	6	0.47	0.39	0.42	0.35	0.4	0.5	0.8	0.0	0.8	0.6	0.3	0.5
Mean		0.38	0.32	0.40	0.58	2.7	2.5	0.6	0.3	1.1	0.5	0.3	0.4

Table 37. Results of two-way analysis of variance for selected benthic invertebrate parameters measured at Beach Nourishment Area O-57.0 in the lower Columbia River, July and October 1994 and January and April 1995. Four stations were sampled along both the 15-m and 30-m transects in the beach nourishment area; these parallel transects were located about 15 and 30 m from the high tide mark on the beach. A significant difference ( $P \leq 0.05$ ) is indicated with an \*.

Parameter	Source	Degrees of freedom	F	P value
Benthic invertebrate density ( $\log_{10}(\text{value} + 1)$ ), total	Month	3	0.20	0.899
	Transect	1	15.03	0.001*
	Total	31		
<i>Corophium</i> spp. density ( $\log_{10}(\text{value} + 1)$ )	Month	3	0.07	0.978
	Transect	1	7.39	0.012*
	Total	31		
Diversity (H)	Month	3	3.39	0.034*
	Transect	1	2.93	0.100
	Total	31		
Equitability (E)	Month	3	2.14	0.122
	Transect	1	10.20	0.004*
	Total	31		

Table 38. Benthic invertebrate densities (number/m<sup>2</sup>) at Beach Nourishment Area O-57.0 and two stations (1 and 2) outside of the area in the lower Columbia River, July 1994 through April 1995. In the "Area" column, the "O" refers to Oregon, and the succeeding number refers to the approximate location in river miles from the mouth of the river. Generally, each density is the mean of 10 replicate samples collected at a station; the standard deviation (SD) is also shown for each density. Odd- and even-numbered stations were located about 15 and 30 m, respectively, from the high tide mark on the beach.

Area	Sta.	July		October		January		April	
		No./m <sup>2</sup>	SD	No./m <sup>2</sup>	SD	No./m <sup>2</sup>	SD	No./m <sup>2</sup>	SD
O-57.0	1	4,810	2,752	6,271	5,075	5,498	2,073	3,436	1,403
O-57.0	2	16,750	4,847	14,002	3,190	18,984	7,794	14,087	3,344
Mean		10,780		10,137		12,241		8,762	
O-57.0	3	9,878	4,194	3,608	2,135	7,903	5,182	3,951	1,355
O-57.0	4	114,589	65,665	36,937	15,393	90,452	28,043	85,727	24,740
O-57.0	5	2,663	3,587	573	859	1,031	887	773	752
O-57.0	6	1,460	1,075	13,314	6,681	2,749	1,660	687	543
O-57.0	7	5,841	3,260	4,553	2,183	3,092	3,368	2,319	1,218
O-57.0	8	19,671	6,672	36,593	9,020	49,220	7,390	42,606	15,378
O-57.0	9	3,522	1,739	4,553	2,106	3,436	2,273	2,768	1,272
O-57.0	10	18,898	7,956	12,198	5,593	10,136	5,534	15,290	3,816
Mean		22,065		14,041		21,002		19,265	

than those in the beach nourishment area in all months (Table 38). No statistical analysis was performed because only two stations were sampled in the undisturbed area.

The mean numbers of taxa/categories (by month) collected in the beach nourishment area were similar, ranging from 6 to 8 (Table 39). In the undisturbed area, the mean numbers of taxa/categories (by month) collected ranged from 4 to 7. Major benthic invertebrate taxa collected in the beach nourishment area included nemerteans, oligochaetes, *Corbicula fluminea*, *Corophium salmonis*, Chironomidae larvae, and Ceratopogonidae larvae (Table 40).

Densities of *Corophium* spp. were not significantly different (ANOVA,  $P > 0.05$ ) between months in Beach Nourishment Area O-57.0; however, densities were significantly higher ( $P < 0.05$ ) at stations along the 30-m transect than at stations along the 15-m transect (Tables 37 and 40). Mean densities of *Corophium* spp. at stations along the 15-m transect ranged from 1,322 organisms/m<sup>2</sup> in April 1995 to 3,543 organisms/m<sup>2</sup> in July 1994. At stations along the 30-m transect, mean densities of *Corophium* spp. ranged from 4,274 organisms/m<sup>2</sup> in July 1994 to 14,602 organisms/m<sup>2</sup> in January 1995 (Table 40). Densities of *Corophium* spp. also varied spatially along each transect (Fig. 9). With the exception of July 1994, mean densities of *Corophium* spp. along the 15-m transect in the undisturbed area (Station 1) outside of the beach nourishment area were higher than mean densities at stations along the 15-m transect in the beach nourishment area (Table 40). In July 1994 and January 1995, mean densities of *Corophium* spp. along the 30-m transect in the undisturbed area (Station 2) outside of the beach nourishment area were higher than mean densities at stations along the 30-m transect in the beach nourishment area, whereas in October 1994 and April 1995, the reverse was true.

Table 39. Numbers of taxa/categories, Diversities (H), and Equitabilities (E) at Beach Nourishment Area O-57.0 and two stations (1 and 2) outside of the area in the lower Columbia River, July 1994 through April 1995. In the "Area" column, the "O" refers to Oregon, and the succeeding number refers to the approximate location in river miles from the mouth of the river. Odd- and even-numbered stations were located about 15 and 30 m, respectively, from the high tide mark on the beach.

Area	Sta.	July			October			January			April		
		No. taxa	H	E	No. taxa	H	E	No. taxa	H	E	No. taxa	H	E
O-57.0	1	5	1.32	0.57	4	0.92	0.46	4	0.71	0.35	3	0.75	0.47
O-57.0	2	9	1.47	0.47	9	1.48	0.47	7	0.72	0.26	5	0.98	0.42
Mean		7	1.40	0.52	7	1.20	0.47	6	0.72	0.30	4	0.86	0.44
O-57.0	3	6	1.02	0.39	5	1.88	0.81	5	1.60	0.69	4	1.25	0.63
O-57.0	4	8	0.36	0.12	10	1.92	0.58	12	1.35	0.38	13	1.26	0.34
O-57.0	5	2	0.35	0.35	4	1.92	0.96	4	1.78	0.89	4	1.66	0.83
O-57.0	6	4	1.32	0.66	6	1.59	0.61	5	1.61	0.69	4	1.81	0.91
O-57.0	7	6	1.43	0.55	6	1.50	0.58	7	2.25	0.80	7	1.81	0.65
O-57.0	8	8	1.17	0.39	9	1.37	0.43	11	1.32	0.38	13	1.38	0.37
O-57.0	9	7	2.22	0.79	6	2.20	0.85	6	2.41	0.93	5	2.17	0.93
O-57.0	10	6	1.57	0.61	7	1.64	0.58	6	1.89	0.73	10	1.76	0.53
Mean		6	1.18	0.48	7	1.75	0.68	7	1.78	0.69	8	1.64	0.65



Table 40. Mean densities (number/m<sup>2</sup>) and standard deviations (SD) of benthic invertebrates collected at Beach Nourishment Area O-57.0 and two stations (1 and 2) outside of the area in the lower Columbia River, July 1994 through April 1995.

Four stations were sampled along both the 15-m and 30-m transects in the beach nourishment area; these parallel transects were located about 15 and 30 m from the high tide mark on the beach. Each density represents the mean of all samples collected along a particular transect. Any addition discrepancies in totals are due to rounding.

Taxon	July		October		January		April	
	No./m <sup>2</sup>	SD	No./m <sup>2</sup>	SD	No./m <sup>2</sup>	SD	No./m <sup>2</sup>	SD
<b>BEACH NOURISHMENT AREA (15-m)</b>								
Nemertea	64	301	507	781	330	672	176	448
Turbellaria	0	0	22	138	66	232	66	232
Oligochaeta	1,052	2,017	242	481	462	878	507	730
Fluminicola virens	86	379	44	192	66	304	0	0
Corbicula fluminea	387	549	683	928	1,123	1,818	220	471
Ostracoda	22	136	0	0	22	138	0	0
Corophium spp.	64	229	0	0	0	0	0	0
Corophium salmonis	3,479	3,876	1,608	1,639	1,652	2,392	1,322	1,405
Chironomidae larvae	279	492	44	192	0	0	22	138
Ceratopogonidae larvae	43	190	242	556	154	478	132	371
Total	5,476	4,265	3,392	2,453	3,876	4,114	2,445	1,620

Table 40. Continued.

Taxon	July		October		January		April	
	No./m <sup>2</sup>	SD	No./m <sup>2</sup>	SD	No./m <sup>2</sup>	SD	No./m <sup>2</sup>	SD
<b>BEACH NOURISHMENT AREA (30-m)</b>								
Nemertea	22	136	451	953	730	882	322	539
Turbellaria	0	0	86	326	107	347	451	891
Polychaeta	22	136	0	0	0	0	0	0
Neanthes limnicola	43	190	22	136	0	0	43	272
Oligochaeta	32,577	54,434	10,673	11,923	19,907	28,811	19,112	28,980
Fluminicola virens	172	444	472	972	193	412	43	190
Corbicula fluminea	107	347	1,353	1,480	537	1,129	623	825
Pisidium spp.	0	0	22	136	43	190	43	272
Ostracoda	64	229	258	830	838	2,613	730	1,127
Hyalella azteca	0	0	0	0	22	136	0	0
Corophium salmonis	4,274	4,083	10,029	5,246	14,538	13,761	13,551	12,968
Corophium spinicorne	0	0	0	0	64	229	64	229
Harpacticoida	0	0	0	0	0	0	64	229
Diptera pupae	0	0	0	0	0	0	22	136
Chironomidae larvae	859	1,199	215	466	558	838	558	860
Chironomidae pupae	0	0	0	0	0	0	22	136
Ceratopogonidae larvae	494	931	1,009	2,292	408	1,167	236	514
Odonata nymph	0	0	0	0	0	0	22	136
Ephemeroptera nymph	22	136	64	301	150	384	107	347
Hydracarina	0	0	107	288	43	190	64	229
Total	38,655	55,190	24,760	15,458	38,139	38,173	36,078	35,696

Table 40. Continued.

Taxon	July		October		January		April	
	No./m <sup>2</sup>	SD	No./m <sup>2</sup>	SD	No./m <sup>2</sup>	SD	No./m <sup>2</sup>	SD
OUTSIDE OF BEACH NOURISHMENT AREA (15-m)								
Oligochaeta	601	1,075	258	580	172	362	344	601
Lymnaea spp.	0	0	0	0	86	272	0	0
Corbicula fluminea	172	362	859	906	430	453	172	362
Corophium salmonis	3,522	2,234	5,068	4,370	4,810	2,150	2,921	1,008
Chironomidae larvae	172	362	86	272	0	0	0	0
Ceratopogonidae larvae	344	1,086	0	0	0	0	0	0
Total	4,810	2,752	6,271	5,075	5,498	2,073	3,436	1,403
OUTSIDE OF BEACH NOURISHMENT AREA (30-m)								
Nemertea	0	0	0	0	86	272	86	272
Nematomorpha	86	272	0	0	0	0	0	0
Neanthes limnicola	0	0	86	272	0	0	0	0
Oligochaeta	1,976	1,672	2,319	1,406	601	707	1,460	1,571
Gastropoda	0	0	86	272	0	0	0	0
Fluminicola virens	258	580	258	580	172	362	258	580
Corbicula fluminea	344	830	1,460	1,284	1,117	1,218	859	1,071
Ostracoda	86	272	0	0	0	0	0	0
Corophium spp.	172	543	0	0	0	0	0	0
Corophium salmonis	12,198	3,922	9,535	3,914	16,836	6,656	11,425	3,437
Corophium spinicorne	0	0	0	0	86	272	0	0
Chironomidae larvae	859	1,403	86	272	0	0	0	0
Chironomidae pupae	0	0	86	272	0	0	0	0
Ceratopogonidae larvae	773	945	0	0	86	272	0	0
Odonata nymph	0	0	86	272	0	0	0	0
Total	16,750	4,846	14,002	3,190	18,984	7,794	14,087	3,344

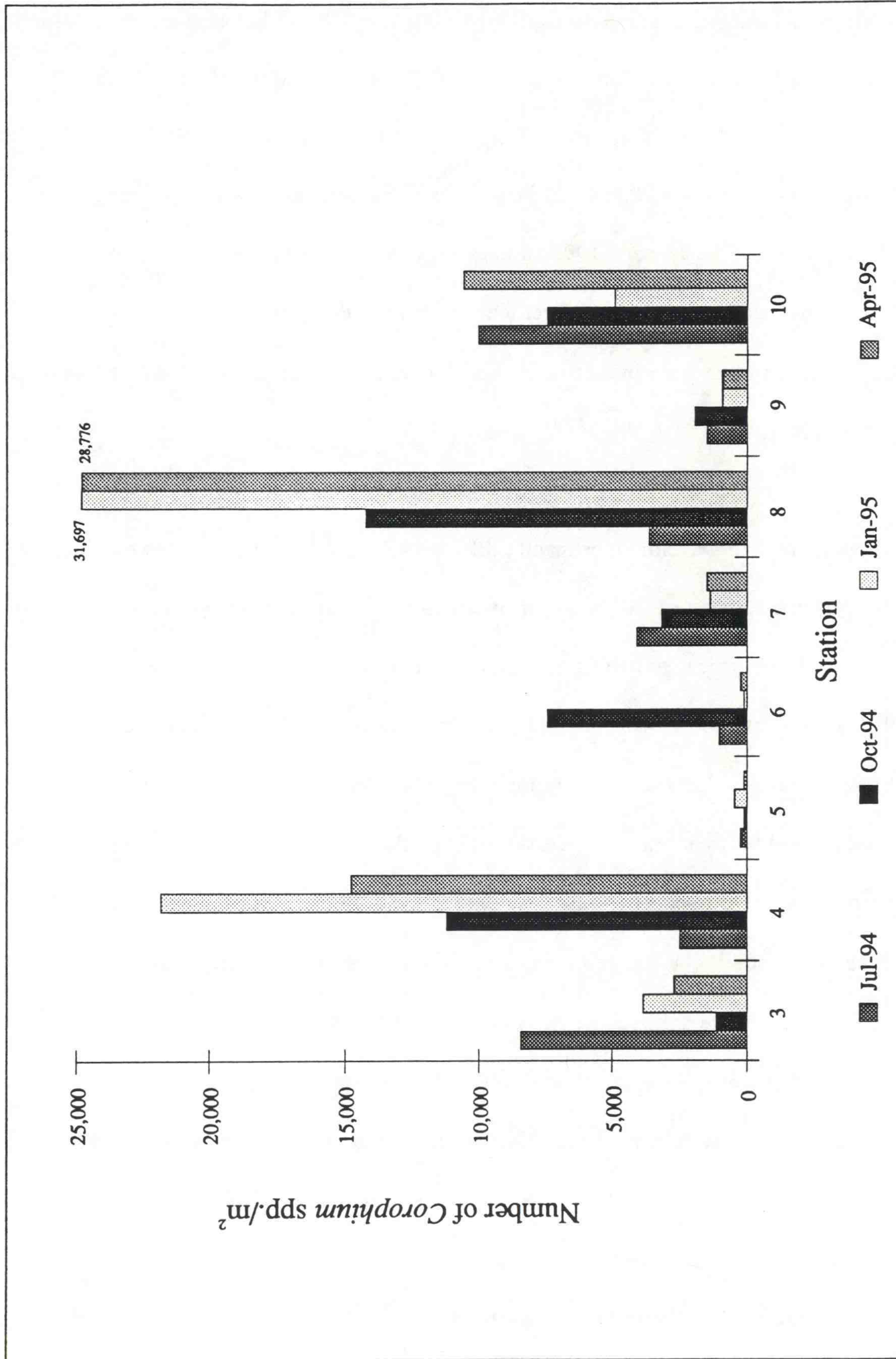

Figure 9. Number of *Corophium* spp./m<sup>2</sup> by station at Beach Nourishment Area O-57.0 in the lower Columbia River. Sampling was conducted in July and October 1994 and January and April 1995. Stations 1 and 2 were control stations outside the study area. Odd- and even-numbered stations were located about 15 and 30 m, respectively, from the high tide mark on the beach.

Diversity (H) was significantly different (ANOVA,  $P < 0.05$ ) between months, but not between transects in Beach Nourishment Area O-57.0 (Table 37). Mean H values ranged from 1.18 in July 1994 to 1.78 in January 1995 (Table 39). Equitability (E) was not significantly different (ANOVA,  $P > 0.05$ ) between months, with mean values ranging from 0.48 in July 1994 to 0.69 in January 1995. Equitability was significantly higher (ANOVA,  $P < 0.05$ ) at stations along the 15-m transect than at stations along the 30-m transect (Table 37). Mean H and E values were higher in the beach nourishment area than in the undisturbed area, except in July 1994 (Table 39).

### **Sediments**

Median grain size was not significantly different (ANOVA,  $P > 0.05$ ) between months in Beach Nourishment Area O-57.0; however, it was significantly higher ( $P < 0.05$ ) at stations along the 15-m transect (mean = 0.30 mm) than at stations along the 30-m transect (mean = 0.17 mm) (Table 41). Mean median grain size in the beach nourishment area ranged from 0.22 mm in January 1995 to 0.26 mm in July 1994. Percent silt/clay was not significantly different between months (Kruskal-Wallis,  $P > 0.05$ ), but was significantly lower at stations along the 15-m transect (Kruskal-Wallis,  $P < 0.05$ ) than at stations along the 30-m transect. Mean percent silt/clay ranged from 6.4% in July 1994 to 9.2% in January 1995 (Table 41). Percent volatile solids were not significantly different between months (Kruskal-Wallis,  $P > 0.05$ ), but were significantly lower ( $P < 0.05$ ) at stations along the 15-m transect than at stations along the 30-m transect (Table 41). In the beach nourishment area, mean percent volatile solids ranged from 0.8 to 0.9% throughout the study. Mean median grain size was lower in the undisturbed area outside of the beach nourishment area than in the beach nourishment area (Table 41). With the exception of July 1994, mean percent silt/clay values

Table 41. Sediment characteristics at Beach Nourishment Area O-57.0 and two stations (1 and 2) outside of the area in the lower Columbia River, July 1994 through April 1995. In the "Area" column, the "O" refers to Oregon, and the succeeding number refers to the approximate location in river miles from the mouth of the river.

Area	Sta.	Median grain size (mm)				silt/clay (%)				Volatile solids (%)			
		Jul	Oct	Jan	Apr	Jul	Oct	Jan	Apr	Jul	Oct	Jan	Apr
O-57.0	1	0.17	0.16	0.15	0.18	0.7	6.9	17.7	0.8	0.8	0.9	0.9	0.7
O-57.0	2	0.15	0.10	0.14	0.13	7.1	33.2	20.8	28.9	0.3	2.6	1.2	2.5
Mean		0.16	0.13	0.14	0.16	3.9	20.0	19.2	14.8	0.6	1.8	1.0	1.6
O-57.0	3	0.22	0.26	0.21	0.23	0.5	0.5	1.1	0.2	0.5	0.3	0.8	0.5
O-57.0	4	0.15	0.19	0.17	0.15	27.2	14.5	22.5	29.3	1.5	1.5	2.3	2.2
O-57.0	5	0.47	0.29	0.29	0.33	0.3	0.4	0.6	0.4	0.4	0.7	0.2	0.4
O-57.0	6	0.23	0.22	0.26	0.28	0.2	0.6	0.4	0.1	1.1	0.8	0.2	0.6
O-57.0	7	0.30	0.28	0.24	0.24	0.4	0.3	1.5	1.3	0.4	0.9	0.6	0.4
O-57.0	8	0.11	0.11	0.12	0.10	18.8	12.2	22.4	23.2	1.6	1.4	1.6	1.4
O-57.0	9	0.39	0.33	0.34	0.34	0.9	0.9	0.4	0.8	0.8	0.8	0.2	0.4
O-57.0	10	0.25	0.13	0.14	0.16	2.7	29.2	24.5	8.4	0.6	1.1	0.3	0.6
Mean		0.26	0.23	0.22	0.23	6.4	7.3	9.2	8.0	0.9	0.9	0.8	0.8

in the undisturbed area outside of the beach area were higher than mean values in the beach nourishment area. Mean percent volatile solids were 1.8% or less for both the undisturbed area and the beach nourishment area (Table 41).

### Beach Nourishment Area W-70.1

#### Benthic Invertebrates

At Beach Nourishment Area W-70.1, benthic invertebrate densities (total) were not significantly different between months (ANOVA,  $P > 0.05$ ) (Table 42); the lowest mean density occurred in January 1995 (3,561 organisms/m<sup>2</sup>) and the highest in July 1994 (5,541 organisms/m<sup>2</sup>) (Table 43). Benthic invertebrate densities were significantly different between the 15- and 30-m transects ( $P < 0.05$ ), with the highest densities generally occurring at stations along the 30-m transect (Tables 42 and 43).

The mean numbers of taxa/categories collected in the beach nourishment area were similar for each month, ranging from four to five (Table 44). Major benthic invertebrate taxa collected in the beach nourishment area included oligochaetes, *Corbicula fluminea*, and *Corophium salmonis* (Table 45).

Densities of *Corophium* spp. were not significantly different (ANOVA,  $P > 0.05$ ) between months in Beach Nourishment Area W-70.1; however, densities were significantly higher ( $P < 0.05$ ) at stations along the 30-m transect than at stations along the 15-m transect (Tables 42 and 45). Mean densities of *Corophium* spp. at stations along the 15-m transect ranged from 12 organisms/m<sup>2</sup> in January 1995 to 221 organisms/m<sup>2</sup> in July 1994. At stations along the 30-m transect, mean densities of *Corophium* spp. ranged from 3,067 organisms/m<sup>2</sup>

Table 42. Results of two-way analysis of variance for selected benthic invertebrate parameters measured at Beach Nourishment Area W-70.1 in the lower Columbia River, July and October 1994 and January and April 1995. Seven stations were sampled along both the 15-m and 30-m transects in the beach nourishment area; these parallel transects were located about 15 and 30 m from the high tide mark on the beach. A significant difference ( $P \leq 0.05$ ) is indicated with an \*.

Parameter	Source	Degrees of freedom	F	P value
Benthic invertebrate density ( $\log_{10}(\text{value} + 1)$ ), total	Month	3	0.13	0.940
	Transect	1	13.33	0.001*
	Total	55		
<i>Corophium</i> spp. density ( $\log_{10}(\text{value} + 1)$ )	Month	3	0.68	0.568
	Transect	1	14.08	0.000*
	Total	55		
Diversity (H)	Month	3	0.85	0.472
	Transect	1	6.78	0.012*
	Total	55		
Equitability (E)	Month	3	1.52	0.222
	Transect	1	2.08	0.156
	Total	55		



Table 43. Benthic invertebrate densities (number/m<sup>2</sup>) at Beach Nourishment Area W-70.1 in the lower Columbia River, July 1994 through April 1995. In the "Area" column, the "W" refers to Washington, and the succeeding number refers to the approximate location in river miles from the mouth of the river. Generally, each density is the mean of 10 replicate samples collected at a station; the standard deviation (SD) is also shown for each density. Odd- and even-numbered stations were located about 15 and 30 m, respectively, from the high tide mark on the beach.

Area	Sta.	July		October		January		April	
		No./m <sup>2</sup>	SD	No./m <sup>2</sup>	SD	No./m <sup>2</sup>	SD	No./m <sup>2</sup>	SD
W-70.1	1	1,117	815	2,233	1,864	687	887	773	1,028
W-70.1	2	1,374	1,471	2,663	1,245	1,203	1,950	1,117	910
W-70.1	3	86	272	172	362	1,804	1,485	945	634
W-70.1	4	2,921	1,908	1,031	1,056	2,004	2,612	3,436	1,856
W-70.1	5	2,062	1,630	2,062	1,774	1,031	789	430	453
W-70.1	6	12,112	4,900	3,350	1,739	1,374	1,471	3,436	1,670
W-70.1	7	86	272	0	0	344	724	172	362
W-70.1	8	172	362	86	272	773	854	1,117	1,406
W-70.1	9	35,133	35,812	945	854	430	607	172	362
W-70.1	10	6,872	2,920	21,217	5,218	31,095	7,797	26,715	6,497
W-70.1	11	687	975	3,951	2,368	859	810	1,031	1,056
W-70.1	12	14,517	6,960	15,376	5,193	7,903	6,165	14,087	4,114
W-70.1	13	86	272	95	286	86	272	86	272
W-70.1	14	344	444	945	1,105	258	415	3,092	2,503
Mean		5,541		3,866		3,561		4,044	

Table 44. Numbers of taxa/categories, Diversities (H), and Equitabilities (E) at Beach Nourishment Area W-70.1 in the lower Columbia River, July 1994 through April 1995. In the "Area" column, the "W" refers to Washington, and the succeeding number refers to the approximate location in river miles from the mouth of the river. Odd- and even-numbered stations were located about 15 and 30 m, respectively, from the high tide mark on the beach.

Area	Sta.	July			October			January			April		
		No. taxa	H	E	No. taxa	H	E	No. taxa	H	E	No. taxa	H	E
W-70.1	1	3	1.58	0.99	4	1.27	0.64	4	1.55	0.77	5	2.06	0.89
W-70.1	2	5	1.80	0.78	4	1.59	0.80	4	1.48	0.74	5	2.10	0.91
W-70.1	3	1	0.00	0.00	1	0.00	0.00	2	0.96	0.96	4	1.98	0.99
W-70.1	4	4	1.76	0.88	3	1.04	0.66	5	1.88	0.81	6	2.31	0.89
W-70.1	5	5	1.78	0.76	5	1.50	0.64	3	0.82	0.52	2	0.72	0.72
W-70.1	6	10	2.45	0.74	4	1.41	0.71	5	2.05	0.88	6	1.56	0.60
W-70.1	7	1	0.00	0.00	0	0.00	0.00	3	1.50	0.95	1	0.00	0.00
W-70.1	8	2	1.00	1.00	1	0.00	0.00	2	0.50	0.50	5	1.91	0.82
W-70.1	9	1	0.00	0.00	4	1.28	0.64	4	1.92	0.96	2	1.00	1.00
W-70.1	10	6	1.00	0.39	7	1.15	0.41	8	0.86	0.29	9	0.95	0.30
W-70.1	11	4	1.75	0.88	6	2.06	0.80	6	2.37	0.92	2	0.65	0.65
W-70.1	12	7	1.37	0.49	7	2.41	0.86	7	2.24	0.80	10	2.45	0.74
W-70.1	13	1	0.00	0.00	1	0.00	0.00	1	0.00	0.00	1	0.00	0.00
W-70.1	14	1	0.00	0.00	4	1.49	0.75	2	0.92	0.92	6	2.04	0.79
Mean		4	1.04	0.49	4	1.09	0.49	4	1.36	0.72	5	1.41	0.66

Table 45. Mean densities (number/m<sup>2</sup>) and standard deviations (SD) of benthic invertebrates collected at Beach Nourishment Area W-70.1 in the lower Columbia River, July 1994 through April 1995. Seven stations were sampled along both the 15-m and 30-m transects in the beach nourishment area; these parallel transects were located about 15 and 30 m from the high tide mark on the beach. Each density represents the mean of all samples collected along a particular transect. Any addition discrepancies in totals are due to rounding.

Taxon	July		October		January		April	
	No./m <sup>2</sup>	SD	No./m <sup>2</sup>	SD	No./m <sup>2</sup>	SD	No./m <sup>2</sup>	SD
<b>BEACH NOURISHMENT AREA (15-m)</b>								
Nemertea	0	0	261	798	24	144	37	175
Nematomorpha	12	103	0	0	0	0	0	0
Turbellaria	0	0	12	103	49	201	37	175
Oligochaeta	5,215	17,858	162	449	270	612	160	421
Gastropoda	0	0	0	0	0	0	24	205
Planorbidae	0	0	12	103	0	0	0	0
Fluminicola virens	0	0	12	103	24	144	12	103
Corbicula fluminea	110	324	647	1,154	319	640	184	483
Corophium salmonis	221	615	87	261	12	103	24	144
Chironomidae larvae	12	103	0	0	0	0	0	0
Ceratopogonidae larvae	37	175	174	479	37	175	24	144
Collembola adult	0	0	0	0	12	103	0	0
Hydracarina	0	0	0	0	0	0	12	103
Total	5,608	17,768	1,369	1,906	748	980	515	737

Table 45. Continued.

Taxon	July		October		January		April	
	No./m <sup>2</sup>	SD	No./m <sup>2</sup>	SD	No./m <sup>2</sup>	SD	No./m <sup>2</sup>	SD
<b>BEACH NOURISHMENT AREA (30-m)</b>								
Nemertea	393	1,525	577	1,140	336	694	368	896
Nematomorpha	25	205	0	0	0	0	0	0
Turbellaria	86	298	0	0	37	176	344	779
Oligochaeta	442	850	834	1,356	834	1,443	1,534	2,036
Planorbidae	0	0	0	0	0	0	12	103
<i>Fluminicola virens</i>	12	103	405	1,525	124	449	110	324
<i>Corbicula fluminea</i>	761	1,060	1,190	1,397	660	1,518	503	907
Ostracoda	0	0	24	144	0	0	12	103
<i>Corophium salmonis</i>	3,105	4,694	3,043	6,342	4,133	9,754	4,307	7,838
<i>Corophium spinicorne</i>	0	0	24	144	50	202	0	0
Harpacticoida	12	103	0	0	0	0	12	103
Chironomidae larvae	368	835	0	0	25	145	61	223
Ceratopogonidae larvae	258	660	282	616	187	689	294	525
Trichoptera larvae	0	0	0	0	0	0	12	103
Collembola adult	12	103	0	0	0	0	0	0
Hydracarina	0	0	0	0	50	202	0	0
Total	5,473	6,415	6,381	8,314	6,436	11,192	7,571	9,429

in October 1994 to 4,307 organisms/m<sup>2</sup> in April 1995 (Table 45). Densities of *Corophium* spp. also varied spatially along each transect (Fig. 10).

Diversity (H) and Equitability (E) were not significantly different (ANOVA,  $P > 0.05$ ) between months (Table 42). Mean H values ranged from 1.04 in July 1994 to 1.41 in April 1995, and mean E values ranged from 0.49 in July and October 1994 to 0.72 in January 1995 (Table 44). Diversity was significantly higher (ANOVA,  $P < 0.05$ ) at stations along the 30-m transect than at stations along the 15-m transect; however, E was not significantly different between transects (Table 42).

### **Sediments**

Median grain size was not significantly different (ANOVA,  $P > 0.05$ ) between months or transects in Beach Nourishment Area W-70.1. Mean median grain size in the beach nourishment area ranged from 0.45 mm in October 1994 and January 1995 to 0.52 mm in April 1995 (Table 46). Percent silt/clay was not significantly different between months or transects (Kruskal-Wallis,  $P > 0.05$ ). Mean percent silt/clay ranged from 0.6% in July 1994 to 1.7% in October 1994 (Table 46). Percent volatile solids were significantly different between months (Kruskal-Wallis,  $P < 0.05$ ), but were not significantly different between transects (Kruskal-Wallis,  $P > 0.05$ ). Mean percent volatile solids ranged from 0.4% in July 1994 and January and April 1995 to 0.7% in October 1994 (Table 46).

### **Beach Nourishment Area O-75.8**

#### **Benthic Invertebrates**

At Beach Nourishment Area O-75.8, benthic invertebrate densities (total) were significantly different between months (ANOVA,  $P < 0.05$ ) (Table 47); the lowest mean

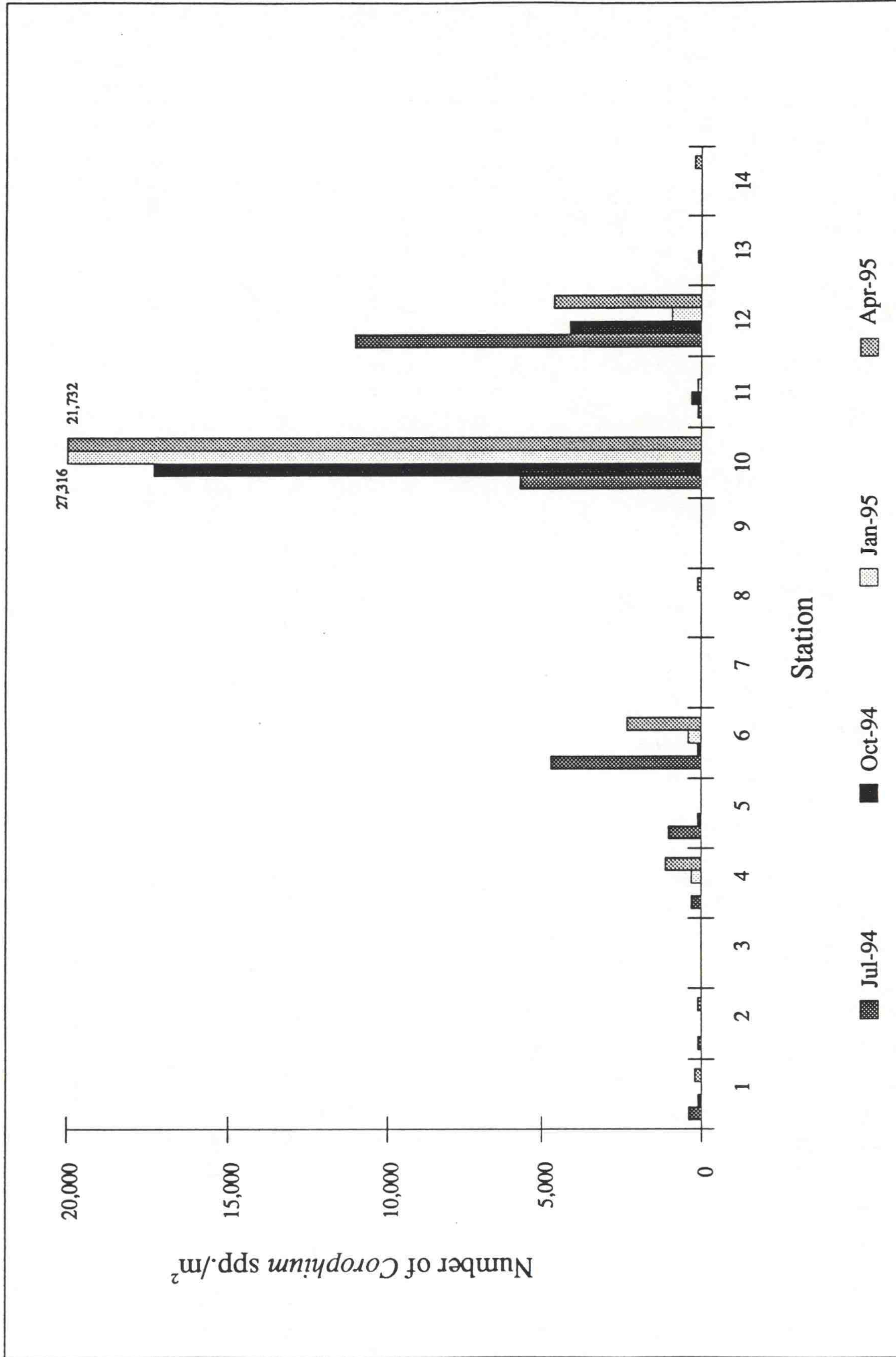

Figure 10. Number of *Corophium* spp./m<sup>2</sup> by station at Beach Nourishment Area W-70.1 in the lower Columbia River. Sampling was conducted in July and October 1994 and January and April 1995. Odd- and even-numbered stations were located about 15 and 30 m, respectively, from the high tide mark on the beach.

Table 46. Sediment characteristics at Beach Nourishment Area W-70.1 in the lower Columbia River, July 1994 through April 1995. In the "Area" column, the "W" refers to Washington, and the succeeding number refers to the approximate location in river miles from the mouth of the river.

Area	Sta.	Median grain size (mm)				Silt/clay (%)				Volatile solids (%)			
		Jul	Oct	Jan	Apr	Jul	Oct	Jan	Apr	Jul	Oct	Jan	Apr
W-70.1	1	0.41	0.34	0.59	0.56	0.2	0.4	0.2	0.4	0.6	0.5	0.5	0.3
W-70.1	2	0.97	0.95	0.49	0.73	0.2	0.1	0.1	0.2	0.3	0.5	0.6	0.3
W-70.1	3	0.26	0.27	0.28	0.27	0.3	0.5	0.3	0.3	0.5	0.7	0.7	0.4
W-70.1	4	0.26	0.28	0.35	0.38	0.5	0.6	0.4	1.1	0.5	0.5	0.2	0.4
W-70.1	5	0.40	0.40	0.43	0.72	0.5	0.2	0.3	0.3	0.6	0.6	0.6	0.5
W-70.1	6	0.88	0.59	0.66	0.60	0.2	0.3	0.2	0.2	0.3	1.0	0.4	0.5
W-70.1	7	0.38	0.35	0.41	0.47	0.3	0.6	0.6	0.5	0.2	0.7	0.6	0.4
W-70.1	8	0.38	0.36	0.39	0.57	0.3	0.7	0.5	0.5	0.3	0.2	0.2	0.4
W-70.1	9	0.44	0.74	0.37	0.34	0.5	4.1	0.9	0.6	0.5	0.8	0.3	0.4
W-70.1	10	0.38	0.27	0.32	0.30	3.1	5.9	1.5	1.0	0.5	1.2	0.6	0.6
W-70.1	11	0.55	0.36	0.44	0.49	0.4	4.8	0.5	0.6	0.5	0.6	0.1	0.2
W-70.1	12	0.44	0.42	0.37	0.36	0.6	4.8	7.0	3.4	0.6	0.8	0.6	0.6
W-70.1	13	0.42	0.43	0.50	0.63	0.5	0.3	0.6	0.1	0.4	0.5	0.2	0.3
W-70.1	14	0.64	0.47	0.66	0.90	0.2	0.3	0.1	0.2	0.4	0.5	0.3	0.3
Mean		0.49	0.45	0.45	0.52	0.6	1.7	0.9	0.7	0.4	0.7	0.4	0.4

Table 47. Results of two-way analysis of variance for selected benthic invertebrate parameters measured at Beach Nourishment Area O-75.8 in the lower Columbia River, July (all samples were collected on 1 August) and October 1994 and January and April 1995. About 274 m (900 ft) of the upper end of Beach Nourishment Area O-74.5 is included with Beach Nourishment Area O-75.8. Four stations were sampled along both the 15-m and 30-m transects in the beach nourishment area; these parallel transects were located about 15 and 30 m from the high tide mark on the beach. A significant difference ( $P \leq 0.05$ ) is indicated with an \*.

Parameter	Source	Degrees of freedom	F	P value
Benthic invertebrate density ( $\log_{10}(\text{value} + 1)$ ), total	Month	3	12.31	0.000*
	Transect	1	12.67	0.002*
	Total	31		
<i>Corophium</i> spp. density ( $\log_{10}(\text{value} + 1)$ )	Month	3	10.26	0.000*
	Transect	1	5.40	0.029*
	Total	31		
Diversity (H)	Month	3	4.55	0.012*
	Transect	1	5.00	0.035*
	Total	31		
Equitability (E)	Month	3	0.84	0.488
	Transect	1	0.61	0.441
	Total	31		



density occurred in January 1995 (1,611 organisms/m<sup>2</sup>) and the highest in July 1994 (8,622 organisms/m<sup>2</sup>) (Table 48). Benthic invertebrate densities were significantly different between the 15- and 30-m transects ( $P < 0.05$ ), with the highest densities generally occurring at stations along the 30-m transect (Tables 47 and 48).

The mean numbers of taxa/categories (by month) collected in the beach nourishment area ranged from three to six (Table 49). Major benthic invertebrate taxa collected in the beach nourishment area included oligochaetes, *Corbicula fluminea*, *Corophium salmonis*, and Ceratopogonidae larvae (Table 50).

Densities of *Corophium* spp. were significantly different (ANOVA,  $P < 0.05$ ) between months in Beach Nourishment Area O-75.8; the highest mean density occurred in October 1994 and the lowest in January 1995 (Table 50). In addition, mean densities of *Corophium* spp. were significantly higher ( $P < 0.05$ ) at stations along the 30-m transect than at stations along the 15-m transect (Tables 47 and 50). Mean densities of *Corophium* spp. at stations along the 15-m transect ranged from 0 organisms/m<sup>2</sup> in January 1995 to 3,672 organisms/m<sup>2</sup> in October 1994. At stations along the 30-m transect, mean densities of *Corophium* spp. ranged from 66 organisms/m<sup>2</sup> in January 1995 to 4,488 organisms/m<sup>2</sup> in July 1994 (Table 50). Densities of *Corophium* spp. also varied spatially along each transect (Fig. 11).

Diversity (H) was significantly different (ANOVA,  $P < 0.05$ ) between months, with mean H values ranging from 1.19 in January 1995 to 1.88 in April 1995 (Table 49). Diversity was significantly higher (ANOVA,  $P < 0.05$ ) at stations along the 30-m transect than at stations along the 15-m transect. Equitability (E) was not significantly different (ANOVA,  $P > 0.05$ ) between months or transects (Table 47). Mean E values ranged from 0.67 in July 1994 to 0.84 in April 1995 (Table 49).

Table 48. Benthic invertebrate densities (number/m<sup>2</sup>) at Beach Nourishment Area O-75.8 in the lower Columbia River, July 1994 through April 1995; about 274 m (900 ft) of the upper end of Beach Nourishment Area O-74.5 is included with Beach Nourishment Area O-75.8. In the "Area" column, the "O" refers to Oregon, and the succeeding number refers to the approximate location in river miles from the mouth of the river. Generally, each density is the mean of 10 replicate samples collected at a station; the standard deviation (SD) is also shown for each density. Odd- and even-numbered stations were located about 15 and 30 m, respectively, from the high tide mark on the beach.

Area	Sta.	July <sup>a</sup>		October		January		April	
		No./m <sup>2</sup>	SD	No./m <sup>2</sup>	SD	No./m <sup>2</sup>	SD	No./m <sup>2</sup>	SD
O-75.8	1	7,130	4,927	3,178	2,530	172	362	2,577	1,670
O-75.8	2	4,123	2,555	4,553	2,836	430	607	2,921	1,579
O-75.8	3	2,319	1,902	3,092	1,820	430	607	1,203	923
O-75.8	4	19,156	11,652	3,522	2,700	4,810	1,679	7,903	4,596
O-75.8	5	2,319	1,986	19,327	6,104	773	634	1,374	1,086
O-75.8	6	4,724	2,035	10,909	5,756	4,295	1,607	2,491	2,082
O-75.8	7	12,112	9,004	3,522	2,377	86	272	601	580
O-75.8	8	17,094	5,776	15,462	4,635	1,890	1,131	3,866	2,370
Mean		8,622		7,946		1,611		2,867	

<sup>a</sup> All samples were collected on 1 August 1994.

Table 49. Numbers of taxa/categories, Diversities (H), and Equitabilities (E) at Beach Nourishment Area O-75.8 in the lower Columbia River, July 1994 through April 1995; about 274 m (900 ft) of the upper end of Beach Nourishment Area O-74.5 is included with Beach Nourishment Area O-75.8. In the "Area" column, the "O" refers to Oregon, and the succeeding number refers to the approximate location in river miles from the mouth of the river. Odd- and even-numbered stations were located about 15 and 30 m, respectively, from the high tide mark on the beach.

Area	Sta.	July <sup>a</sup>			October			January			April		
		No. taxa	H	E	No. taxa	H	E	No. taxa	H	E	No. taxa	H	E
O-75.8	1	4	1.64	0.82	7	2.48	0.88	2	1.00	1.00	7	2.35	0.84
O-75.8	2	4	1.73	0.86	4	1.86	0.93	3	1.37	0.86	6	2.37	0.92
O-75.8	3	2	0.23	0.23	6	1.75	0.68	3	1.37	0.86	3	1.58	1.00
O-75.8	4	4	1.60	0.80	6	1.97	0.76	6	2.17	0.84	6	2.28	0.88
O-75.8	5	3	1.25	0.79	8	1.73	0.58	2	0.76	0.76	5	2.06	0.89
O-75.8	6	5	2.06	0.89	7	2.05	0.73	6	1.41	0.55	4	0.90	0.45
O-75.8	7	3	0.31	0.20	4	1.70	0.85	1	0.00	0.00	4	1.84	0.92
O-75.8	8	5	1.79	0.77	6	1.35	0.52	4	1.46	0.73	4	1.70	0.85
Mean		4	1.33	0.67	6	1.86	0.74	3	1.19	0.70	5	1.88	0.84

<sup>a</sup> All samples were collected on 1 August 1994.

Table 50. Mean densities (number/m<sup>2</sup>) and standard deviations (SD) of benthic invertebrates collected at Beach Nourishment Area O-75.8 in the lower Columbia River, July 1994 through April 1995; about 274 m (900 ft) of the upper end of Beach Nourishment Area O-74.5 is included with Beach Nourishment Area O-75.8. Four stations were sampled along both the 15-m and 30-m transects in the beach nourishment area; these parallel transects were located about 15 and 30 m from the high tide mark on the beach. Each density represents the mean of all samples collected along a particular transect. Any addition discrepancies in totals are due to rounding.

Taxon	July <sup>a</sup>		October		January		April	
	No./m <sup>2</sup>	SD	No./m <sup>2</sup>	SD	No./m <sup>2</sup>	SD	No./m <sup>2</sup>	SD
<b>BEACH NOURISHMENT AREA (15-m)</b>								
Nemertea	0		215	424	43	190	215	505
Turbellaria	0		22	136	0	0	129	366
Oligochaeta	4,338	6,052	773	1,114	43	190	279	596
Corbicula fluminea	472	700	1,696	2,063	43	190	150	384
Corophium salmonis	923	2,108	3,436	5,065	0	0	258	444
Corophium spinicorne	0		236	825	0	0	0	0
Harpacticoida	0		64	229	0	0	0	0
Chironomidae larvae	0		0	0	0	0	22	136
Ceratopogonidae larvae	236	645	838	1,409	236	476	386	513
Total	5,970	6,550	7,280	7,861	365	546	1,439	1,310
<b>BEACH NOURISHMENT AREA (30-m)</b>								
Nemertea	0		172	348	374	783	365	642
Turbellaria	0		22	136	132	314	150	330
Oligochaeta	3,951	4,270	494	580	573	952	430	992
Corbicula fluminea	752	916	2,448	2,403	374	584	773	969
Pisidium spp.	0		0	0	22	138	0	0
Corophium salmonis	4,488	4,957	3,973	4,331	66	232	1,009	1,149
Corophium spinicorne	0		129	311	0	0	0	0
Chironomidae larvae	107	398	86	326	0	0	22	136
Ceratopogonidae larvae	1,976	2,051	1,288	1,965	1,278	1,486	1,546	2,142
Total	11,274	9,498	8,611	6,356	2,819	2,212	4,295	3,528

<sup>a</sup> All samples were collected on 1 August 1994.

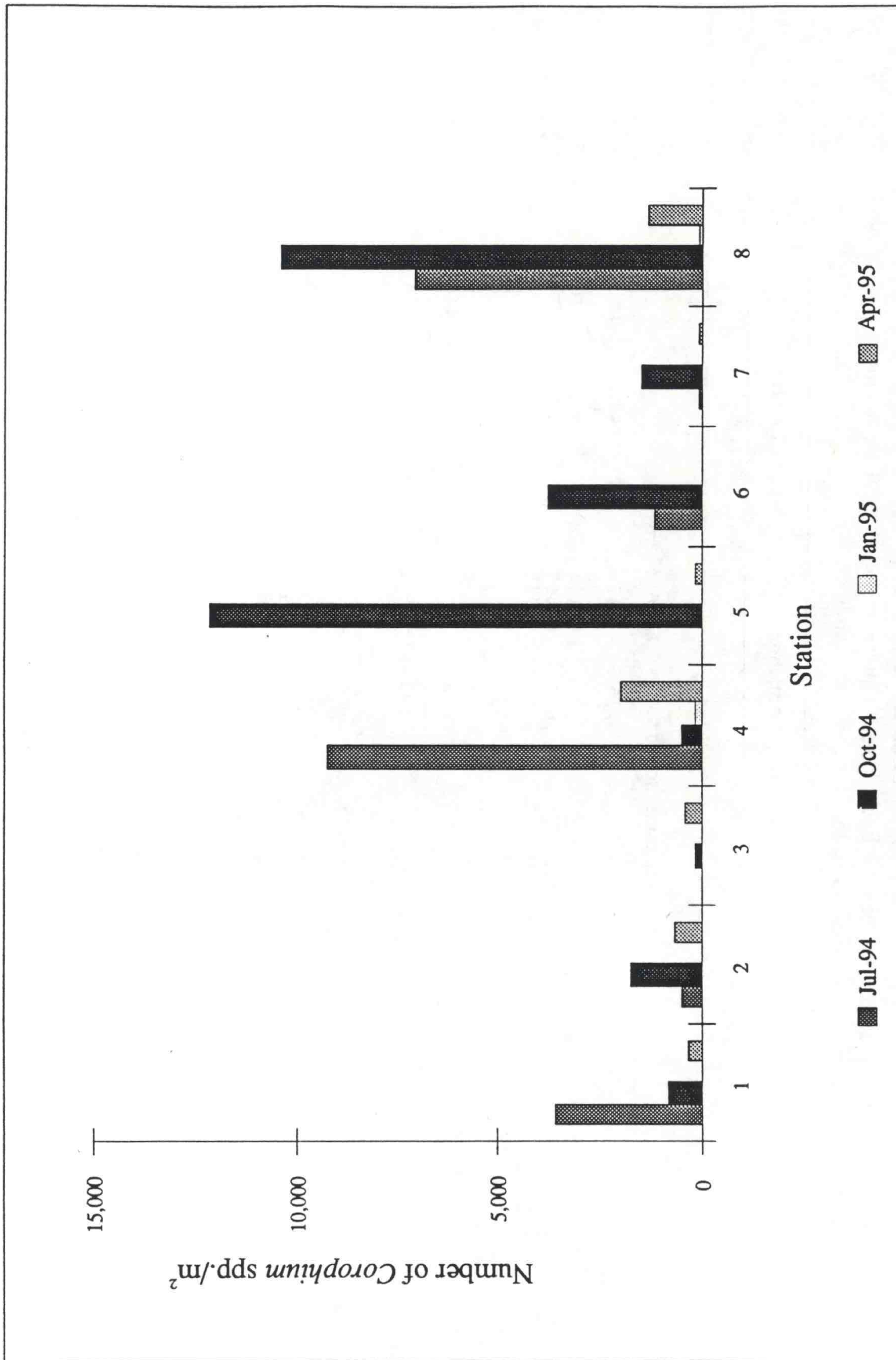

Figure 11. Number of *Corophium* spp./m<sup>2</sup> by station at Beach Nourishment Area O-75.8 in the lower Columbia River. Sampling was conducted in August and October 1994 and January and April 1995. Odd- and even-numbered stations were located about 15 and 30 m, respectively, from the high tide mark on the beach.

## Sediments

Median grain size was not significantly different (ANOVA,  $P > 0.05$ ) between months or transects in Beach Nourishment Area O-75.8. Mean median grain size in the beach nourishment area ranged from 0.40 mm in October 1994 to 0.51 mm in July 1994 (Table 51). Percent silt/clay and percent volatile solids were not significantly different between months or transects (Kruskal-Wallis,  $P > 0.05$ ). Mean percent silt/clay ranged from 0.4% in July 1994 and January 1995 to 2.9% in October 1994, and mean percent volatile solids ranged from 0.5% in January and April 1995 to 0.8% in October 1994 (Table 51).

### Grain Size/*Corophium* spp. Relationship

The regression relationship for median grain size and *Corophium* spp. density was significant ( $P < 0.05$ ). The regression equation was  $\log_{10}(\text{Corophium spp. density} + 1) = 3.13 - 2.51 \times \text{median grain size (mm)}$ ;  $F = 22.66$ ,  $P = 0.000$ , and  $r^2 = 0.05$ . Median grain size was a poor predictor of *Corophium* spp. density, explaining only 5% of the variation in *Corophium* spp. density (transformed).

## DISCUSSION

Assessing the standing crops of benthic invertebrates, particularly *Corophium* spp., in the lower Columbia River is one of the most important means of determining the habitat values of various areas for fishes, including migrating juvenile salmonids. *Corophium salmonis* is an important food for juvenile salmonids (McCabe et al. 1983, 1986; Kirn et al. 1986). *Corophium salmonis* and *C. spinicorne* were the dominant prey for juvenile salmonids collected during spring 1984 at Bonneville Dam (Muir and Emmett 1988). Benthic

Table 51. Sediment characteristics at Beach Nourishment Area O-75.8 in the lower Columbia River, July 1994 through April 1995; about 274 m (900 ft) of the upper end of Beach Nourishment Area O-74.5 is included with Beach Nourishment Area O-75.8. In the "Area" column, the "O" refers to Oregon, and the succeeding number refers to the approximate location in river miles from the mouth of the river.

Area	Sta.	Median grain size (mm)				silt/clay (%)				Volatile solids (%)			
		Jul <sup>a</sup>	Oct	Jan	Apr	Jul	Oct	Jan	Apr	Jul	Oct	Jan	Apr
O-75.8	1	0.79	0.44	0.36	0.40	0.4	5.8	0.3	1.8	0.4	1.7	0.2	0.5
O-75.8	2	0.40	0.38	0.42	0.92	0.8	5.4	0.2	0.6	1.2	0.4	0.4	0.5
O-75.8	3	0.61	0.57	0.41	0.41	0.3	0.3	0.5	0.6	0.4	0.8	0.2	0.4
O-75.8	4	0.36	0.27	0.42	0.22	0.4	6.3	0.5	4.9	0.8	0.5	0.7	0.5
O-75.8	5	0.82	0.40	0.39	0.38	0.2	0.4	0.5	0.4	0.4	0.7	0.6	0.5
O-75.8	6	0.41	0.54	0.59	0.37	0.3	0.2	0.3	0.2	0.5	0.3	0.6	0.5
O-75.8	7	0.41	0.29	0.37	0.29	0.4	1.6	0.6	0.0	0.5	0.7	0.3	0.5
O-75.8	8	0.30	0.28	0.34	0.32	0.4	3.5	0.2	0.3	0.5	0.9	0.7	0.7
Mean		0.51	0.40	0.41	0.41	0.4	2.9	0.4	1.1	0.6	0.8	0.5	0.5

<sup>a</sup> All sediment samples were collected on 1 August 1994.

invertebrate communities are relatively stable on a short-term basis, in contrast to fish communities, which can change rapidly. For example, large numbers of juvenile salmon may be present in a particular area of the river after hatchery releases, which are then followed by a dramatic decline as the juveniles migrate out of the area.

At times, *C. salmonis* is also an important prey for nonsalmonid fishes in the river, including American shad (*Alosa sapidissima*), peamouth (*Mylocheilus caurinus*), threespine stickleback (*Gasterosteus aculeatus*), and starry flounder (*Platichthys stellatus*) (McCabe et al. 1983). Also, juvenile white sturgeon (*Acipenser transmontanus*) in the lower Columbia River prey heavily on *C. salmonis* (Muir et al. 1988, McCabe et al. 1993).

Juvenile salmonids use both nearshore and main channel areas of the lower Columbia River as they migrate to the Pacific Ocean (McCabe et al. 1983, Dawley et al. 1986, Hinton and Emmett 1994). We would expect that juvenile salmonids would migrate along the 10 beach nourishment areas that we studied. In addition, we would expect juvenile salmonids to feed on the abundant populations of *Corophium* spp. in at least some of the these areas.

With the exception of Beach Nourishment Area O-75.8, *Corophium* spp. densities in the beach nourishment areas were not significantly different ( $P > 0.05$ ) between months. In a benthic invertebrate study between River Mile (RM) 25 and 26 in the Columbia River estuary, *Corophium* spp. densities were significantly higher ( $P < 0.05$ ) in May and September than in July 1993; however, densities for May and September were not significantly different ( $P > 0.05$ ) (Hinton et al. 1995). Densities of *C. salmonis* were significantly higher ( $P < 0.05$ ) in September than in July at three wetlands in the Columbia River estuary in 1992 (McCabe and Hinton 1993). At Cottonwood Island (RM 68-71) in the lower Columbia River, *C.*



*salmonis* densities were not significantly different ( $P > 0.05$ ) between July and November 1987, yet densities were significantly higher ( $P < 0.05$ ) in July 1988 than in December 1988 (McCabe et al. 1990).

Benthic invertebrate densities (total and *Corophium* spp.) were significantly higher ( $P < 0.05$ ) at stations along the 30-m transect than at stations along the 15-m transect except at Beach Nourishment Area O-45.1, where there was no significant difference ( $P > 0.05$ ) between transects. Apparently the habitat along the 30-m transects provides a better environment for benthic invertebrate colonization than does the habitat along the 15-m transects, which are closer to the high tide mark on the beach. Generally, the stations along the 30-m transects were in deeper water than stations along the 15-m transects (Appendix Table 1).

All 10 beach nourishment areas supported substantial standing crops of *Corophium* spp. (most of which were *C. salmonis*) at times, particularly at stations along the 30-m transects. To show the true value of these habitats it would have been ideal to have collected benthic invertebrate samples in channel areas away from the shoreline, and then to have compared these collections to those made in the beach nourishment areas. Unfortunately, there is little information available documenting standing crops of *C. salmonis* in channel areas away from the shoreline in the beach nourishment study area. Densities of *C. salmonis* in the 10 beach nourishment areas were generally much higher than densities in 8 channel areas (RM 28-131) during comparable seasons in 1988 and 1989 (McCabe et al. 1993) (Table 52). With the exception of RM 28, standing crops of *C. salmonis* in the 8 channel areas were usually less than 400 organisms/m<sup>2</sup>; whereas in the 10 beach nourishment areas, densities generally exceeded 1,100 organisms/m<sup>2</sup>.

Table 52. Mean densities of *Corophium salmonis* (number/m<sup>2</sup>) at various areas in the lower Columbia River. The eight areas sampled in April and September 1988 and 1989 were generally located in channel areas away from the shoreline (McCabe et al. 1993). Densities for the 10 beach nourishment areas sampled in October 1994 and April 1995 are also shown. The approximate location for an area is shown in River Miles (RM) or the name of the beach nourishment area is listed. The "O" and "W" refer to Oregon and Washington, and the succeeding number refers to the approximate location in river miles from the mouth of the river.

Area	April		September		Apr 1995	Oct 1994
	1988	1989	1988	1989		
RM 28	2,420	221	2,229	1,792	---	---
O-34.0	---	---	---	---	11,914	3,968
W-40.9	---	---	---	---	14,800	5,784
W-43.8	---	---	---	---	13,615	4,052
O-44.0	---	---	---	---	4,433	1,179
W-45.0	---	---	---	---	10,617	2,886
O-45.1	---	---	---	---	6,442	884
O-47.8	---	---	---	---	9,263	315
O-57.0	---	---	---	---	7,436	5,818
W-70.1	---	---	---	---	2,166	1,565
O-75.8	---	---	---	---	634	3,704
RM 75	46	4	44	39	---	---
RM 79	27	1	127	256	---	---
RM 88	117	29	11	651	---	---
RM 95	122	54	184	359	---	---
RM 114	5	5	43	8	---	---
RM 127	23	13	4	12	---	---
RM 131	116	241	79	141	---	---

In conclusion, densities of benthic invertebrates, including *Corophium* spp., generally varied spatially at the 10 beach nourishment sites, with the highest densities typically occurring at stations farthest from the high tide mark on the shore. Although some beach nourishment areas had higher standing crops of *Corophium* spp. than others, all areas supported substantial numbers of *Corophium* spp. at times. Since *Corophium* spp. are important prey for juvenile salmonids, and juvenile salmonids migrate along the beach nourishment areas, it is important to insure that *Corophium* spp. populations in these areas are not adversely impacted.

This report does not constitute formal comments of the NMFS under the Fish and Wildlife Coordination Act or the National Environmental Policy Act.

**ACKNOWLEDGMENTS**

We thank Lawrence Davis, Donald Gruber, and Nathan Cook for their assistance in sampling. We are especially appreciative of the efforts of Randall Cummings, COE, in coordinating and overseeing all the diving activities. The Portland District COE conducted the sediment analyses.

## REFERENCES

- Dawley, E. M., R. D. Ledgerwood, T. H. Blahm, C. W. Sims, J. T. Durkin, R. A. Kim, A. E. Rankis, G. E. Monan, and F. J. Ossiander. 1986. Migrational characteristics, biological observations, and relative survival of juvenile salmonids entering the Columbia River estuary, 1966-1983. Report to Bonneville Power Administration, Contract DE-A179-84BP39652, 256 p. (Available from Bonneville Power Administration, Division of Fish and Wildlife-PJ, P.O. Box 3621, Portland, OR 97208.)
- Hinton, S. A., and R. L. Emmett. 1994. Juvenile salmonid stranding in the lower Columbia River, 1992 and 1993. U.S. Dep. Commer., NOAA Tech. Memo. NMFS-NWFSC-20, 48 p.
- Hinton, S. A., G. T. McCabe, Jr., and R. L. Emmett. 1995. In-water restoration between Miller Sands and Pillar Rock Island, Columbia River: Environmental surveys, 1992-93. U.S. Dep. Commer., NOAA Tech. Memo. NMFS-NWFSC-23, 47 p.
- Kim, R. A., R. D. Ledgerwood, and A. L. Jensen. 1986. Diet of subyearling chinook salmon (*Oncorhynchus tshawytscha*) in the Columbia River estuary and changes effected by the 1980 eruption of Mount St. Helens. Northwest Sci. 60(3):191-196.

Krebs, C. J. 1978. Ecology: the experimental analysis of distribution and abundance.

Harper and Row. New York, 678 p.

McCabe, G. T., Jr., R. L. Emmett, and S. A. Hinton. 1993. Feeding ecology of juvenile white sturgeon (*Acipenser transmontanus*) in the lower Columbia River. Northwest Sci. 67(3):170-180.

McCabe, G. T., Jr., R. L. Emmett, W. D. Muir, and T. H. Blahm. 1986. Utilization of the Columbia River estuary by subyearling chinook salmon. Northwest Sci. 60(2):113-124.

McCabe, G. T., Jr., and S. A. Hinton. 1993. Benthic invertebrates and sediments in vegetated and nonvegetated habitats at three intertidal areas of the Columbia River estuary, 1992. Report to U.S. Army Corps of Engineers, Contract E9592012, 37 p. (Available from Northwest Fisheries Science Center, 2725 Montlake Blvd. E., Seattle, WA 98112.)

McCabe, G. T., Jr., S. A. Hinton, R. L. Emmett, and R. J. McConnell. 1990. Benthic invertebrates, sediment characteristics, and demersal fishes off Cottonwood Island, Columbia River, before and after rock-groin construction, 1987-1988. Report to U.S. Army Corps of Engineers, Contract DACW57-87-F-0641, 17 p. plus appendix. (Available from Northwest Fisheries Science Center, 2725 Montlake Blvd. E., Seattle, WA 98112.)

- McCabe, G. T., Jr., S. A. Hinton, and R. L. Emmett. 1993. Report P. Distribution, abundance, and community structure of benthic invertebrates in the lower Columbia River. *In* R. C. Beamesderfer and A. A. Nigro (editors), Status and habitat requirements of the white sturgeon populations in the Columbia River downstream from McNary Dam, p. 265-284. Report to Bonneville Power Administration, Contract DE-AI79-86BP63584, 421 p. (Available from Bonneville Power Administration, Division of Fish and Wildlife-PJ, P.O. Box 3621, Portland, OR 97208.)
- McCabe, G. T., Jr., W. D. Muir, R. L. Emmett, and J. T. Durkin. 1983. Interrelationships between juvenile salmonids and nonsalmonid fish in the Columbia River estuary. *Fish. Bull.*, U.S. 81(4):815-826.
- Muir, W. D., and R. L. Emmett. 1988. Food habits of migrating salmonid smolts passing Bonneville Dam in the Columbia River, 1984. *Regul. Rivers: Res. and Manage.* 2:1-10.
- Muir, W. D., R. L. Emmett, and R. J. McConnell. 1988. Diet of juvenile and subadult white sturgeon in the lower Columbia River and its estuary. *Calif. Fish and Game* 74(1):49-54.
- Ryan, B. F., B. L. Joiner, and T. A. Ryan, Jr. 1985. *Minitab handbook*, 2nd edition. PWS-KENT Pub., Boston, 386 p.

U.S. Army Corps of Engineers. 1991. Federal navigation projects: Columbia River maintenance disposal plan, main and side channels downstream of Bonneville Dam. Navigation Branch, Operations Division, Portland District, U.S. Army Corps of Engineers, Portland, OR, 161 p.





**APPENDIX**



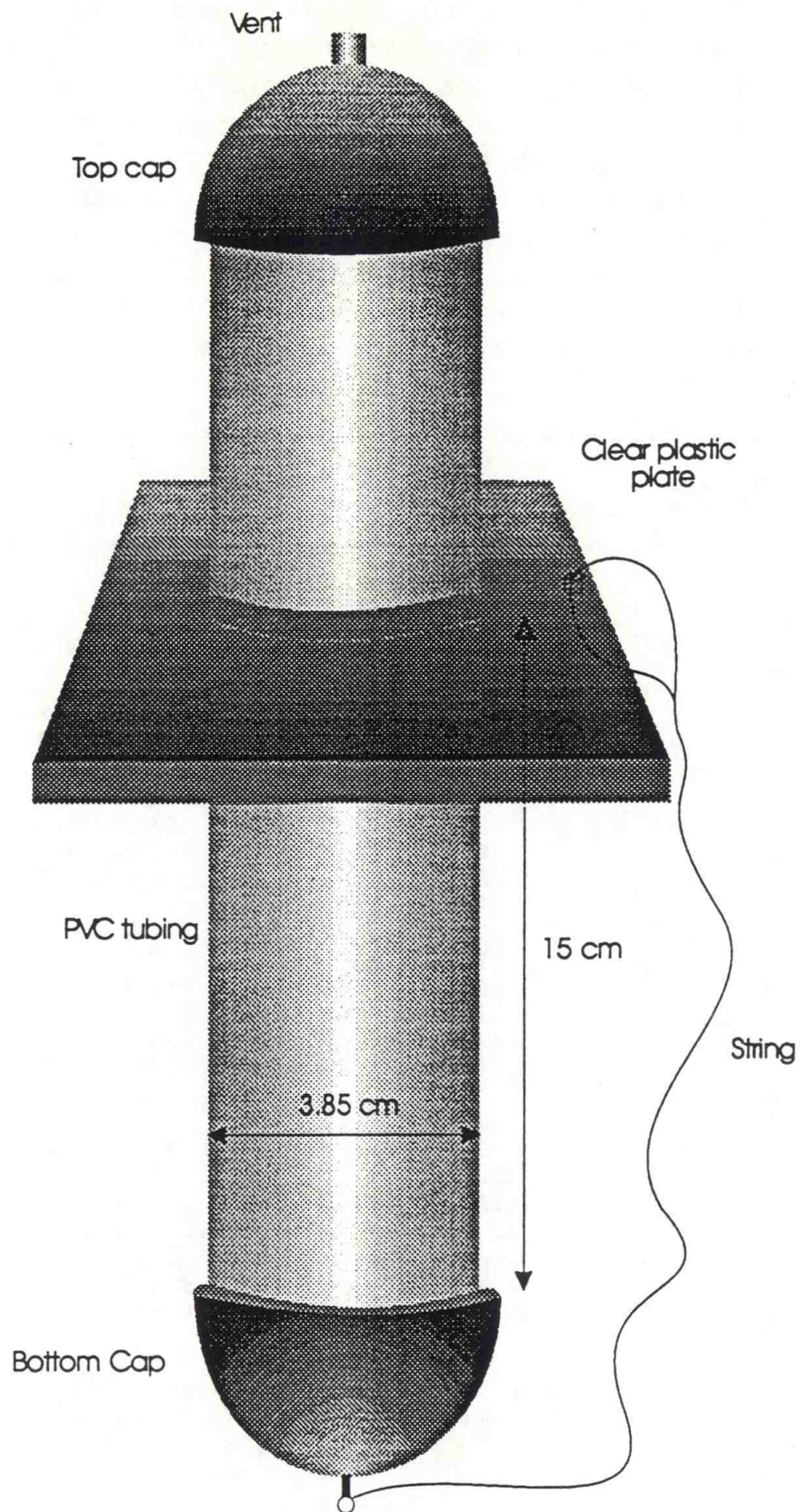

Appendix Figure 1. PVC coring device used to collect benthic invertebrate and sediment samples in 10 beach nourishment areas in the lower Columbia River, July 1994 through April 1995.

Appendix Table 1. Station locations at 10 beach nourishment areas in the lower Columbia River, July 1994 through April 1995. In the "Area" column, the "O" and "W" refer to Oregon and Washington, and the succeeding number refers to the approximate location in river miles from the mouth of the river. Odd- and even-numbered stations were located about 15 and 30 m, respectively, from the high tide mark on the shore. Within an area, the same geographic location is shown for station pairs (i.e., consecutive odd- and even-numbered stations) since the distance between the stations within a pair was less than the accuracy of the Global Positioning System (GPS) if the signal was degraded by the U.S. military. The depth (mean lower low water) is a mean from four surveys.

Area	Station	Mean depth (m)	Latitude	Longitude
O-34.0	1 <sup>a</sup>	2.1	46°15.516'N	123°28.823'W
	2 <sup>a</sup>	6.2	46°15.516'N	123°28.823'W
	3	0.3	46°15.454'N	123°28.307'W
	4	1.5	46°15.454'N	123°28.307'W
	5	0.5	46°15.365'N	123°28.109'W
	6	4.6	46°15.365'N	123°28.109'W
	7	0.1	46°15.273'N	123°27.898'W
	8	1.9	46°15.273'N	123°27.898'W
	9	0.0	46°15.191'N	123°27.692'W
	10	0.0	46°15.191'N	123°27.692'W
	11	0.0	46°15.046'N	123°27.538'W
	12	0.0	46°15.046'N	123°27.538'W
W-40.9	1	0.1	46°10.427'N	123°24.866'W
	2	4.1	46°10.427'N	123°24.866'W
	3	0.0	46°10.367'N	123°24.743'W
	4	3.7	46°10.367'N	123°24.743'W
	5	0.2	46°10.378'N	123°24.608'W
	6	3.7	46°10.378'N	123°24.608'W
W-43.8	1	0.6	46°09.073'N	123°22.314'W
	2	3.6	46°09.073'N	123°22.314'W
	3	0.0	46°09.027'N	123°22.077'W
	4	4.2	46°09.027'N	123°22.077'W
	5	0.0	46°09.013'N	123°21.820'W
	6	3.8	46°09.013'N	123°21.820'W
	7	0.1	46°08.979'N	123°21.686'W
	8	0.2	46°08.979'N	123°21.686'W
O-44.0	1	0.0	46°08.691'N	123°22.628'W
	2	1.7	46°08.691'N	123°22.628'W
	3	0.1	46°08.645'N	123°22.320'W
	4	0.6	46°08.645'N	123°22.320'W
	5	0.0	46°08.629'N	123°22.112'W
	6	1.4	46°08.629'N	123°22.112'W
	7	0.0	46°08.586'N	123°21.720'W
	8	0.1	46°08.586'N	123°21.720'W
	9	0.2	46°08.536'N	123°21.449'W
	10	2.3	46°08.536'N	123°21.449'W
	11	0.0	46°08.482'N	123°21.115'W
	12	0.0	46°08.482'N	123°21.115'W

Appendix Table 1. Continued.

Area	Station	Mean depth (m)	Latitude	Longitude
O-44.0	13	0.0	46°08.433'N	123°20.903'W
	14	0.0	46°08.433'N	123°20.903'W
	15	0.0	46°08.418'N	123°20.519'W
	16	0.0	46°08.418'N	123°20.519'W
	17	0.0	46°08.400'N	123°20.205'W
	18	0.2	46°08.400'N	123°20.205'W
W-45.0	1	0.0	46°08.931'N	123°21.157'W
	2	1.2	46°08.931'N	123°21.157'W
	3	0.0	46°08.900'N	123°20.859'W
	4	2.9	46°08.900'N	123°20.859'W
	5	0.0	46°08.891'N	123°20.590'W
	6	1.1	46°08.891'N	123°20.590'W
	7	0.1	46°08.905'N	123°20.388'W
	8	0.5	46°08.905'N	123°20.388'W
	9	0.0	46°08.921'N	123°20.084'W
	10	0.0	46°08.921'N	123°20.084'W
O-45.1	1	0.0	46°08.361'N	123°20.041'W
	2	0.0	46°08.361'N	123°20.041'W
	3	0.0	46°08.326'N	123°19.721'W
	4	0.0	46°08.326'N	123°19.721'W
O-47.8	1	0.2	46°08.536'N	123°17.320'W
	2	2.4	46°08.536'N	123°17.320'W
	3	0.0	46°08.573'N	123°17.064'W
	4	3.1	46°08.573'N	123°17.064'W
	5	0.0	46°08.609'N	123°16.821'W
	6	2.6	46°08.609'N	123°16.821'W
O-57.0	1 <sup>a</sup>	0.3	46°10.900'N	123°08.307'W
	2 <sup>a</sup>	1.1	46°10.900'N	123°08.307'W
	3	0.3	46°10.728'N	123°07.577'W
	4	1.8	46°10.728'N	123°07.577'W
	5	0.3	46°10.655'N	123°07.307'W
	6	5.2	46°10.655'N	123°07.307'W
	7	0.4	46°10.550'N	123°07.169'W
	8	2.5	46°10.550'N	123°07.169'W
	9	0.2	46°10.421'N	123°06.952'W
	10	0.4	46°10.421'N	123°06.952'W
W-70.1	1	0.4	46°04.630'N	122°53.413'W
	2	0.8	46°04.630'N	122°53.413'W
	3	0.1	46°04.399'N	122°53.293'W
	4	0.3	46°04.399'N	122°53.293'W
	5	0.4	46°04.246'N	122°53.136'W
	6	1.0	46°04.246'N	122°53.136'W
	7	0.0	46°04.024'N	122°53.025'W
	8	0.1	46°04.024'N	122°53.025'W
	9	0.3	46°03.777'N	122°52.842'W
	10	2.4	46°03.777'N	122°52.842'W
	11	0.5	46°03.573'N	122°52.784'W
	12	2.0	46°03.573'N	122°52.784'W
	13	0.0	46°03.372'N	122°52.647'W
	14	0.2	46°03.372'N	122°52.647'W

Appendix Table 1. Continued.

Area	Station	Mean depth (m)	Latitude	Longitude
O-75.8 <sup>b</sup>	1	1.2	46°00.412'N	122°51.498'W
	2	6.1	46°00.412'N	122°51.498'W
	3	0.4	46°00.160'N	122°51.387'W
	4	5.3	46°00.160'N	122°51.387'W
	5	1.1	45°59.945'N	122°51.205'W
	6	5.3	45°59.945'N	122°51.205'W
	7	0.2	45°59.706'N	122°51.232'W
	8	1.4	45°59.706'N	122°51.232'W

<sup>a</sup> Station was located outside of the beach nourishment area.

<sup>b</sup> About 274 m of the upper end of Beach Nourishment Area O-74.5 is included with Beach Nourishment Area O-75.8.