

NORTHEAST FISHERIES SCIENCE CENTER FISHERIES SAMPLING BRANCH OBSERVER OPERATIONS MANUAL 2016



U.S. Department of Commerce
NOAA Fisheries Service
National Marine Fisheries Service
Northeast Fisheries Science Center
Fisheries Sampling Branch
166 Water Street
Woods Hole, MA 02543

Table of Contents

Paperwork Reduction Act Statement	1
Introduction	2
Definitions	2
Benefits of Observing Commercial Fishing Trips.....	3
Observer Safety.....	7
Background Information	7
Be Prepared Even Before You Leave the Dock.....	7
Vessel Orientation Guide	9
Emergencies at Sea	10
Trip Overview.....	13
Trip Selection	13
Preparing for a Trip	13
Before the First Haul	14
During/After Each Haul	16
At the End of the Trip.....	18
Aborted/Broken/Transit Trips.....	19
Communication and Conflict Resolution	20
Gillnet and Beach Seine Fisheries	23
Definitions	23
Safety concerns	26
Gear information.....	26
Observing a Haul	28
Longline Fishery	32
Definitions	32
Safety concerns	34
Gear Information	34
Observing a Haul	37
Pot and Trap Fisheries.....	41
Definitions	41
Safety Concerns	42
Gear Information	42
Observing a Haul	46
Trawl Fisheries	50
Definitions	50
Safety concerns	53
Gear Information	54
Specialized Trawl Net Types.....	61
Observing a Haul	64
High Volume Fisheries	68
Definitions	68
Safety concerns	69
Gear Information	69
Observing a Haul	71
Scallop Fishery	76
Definitions	76

Safety concerns.....	81
Gear Information	81
Observing a Haul.....	82
Clam/Quahog Dredge Fishery.....	86
Definitions.....	86
Safety Concerns	88
Gear Information	88
Observing a Haul.....	89
Incidental Takes and Protected Species Information.....	92
Definitions.....	92
Safety Concerns	93
Being Prepared for an Incidental Take	93
Minimum Sampling.....	94
Marine Mammals	96
Sea Turtles	101
Seabirds	111
Sightings of Protected Species.....	113
Catch Estimation.....	115
Estimation Methods	115
Deckloading	126
Conveyor Strategies.....	131
Catch Composition.....	133
Marel Scales.....	140
Biological Sampling.....	146
Safety concerns.....	146
Individual Animals.....	146
Length Frequencies and Age Structures.....	147
Scallop Sampling.....	152
Clam/Quahog Sampling.....	154
Whelk Sampling	154
Crustacean Sampling	155

List of Figures

Figure 1. Anchored sink gillnet typical configuration.	23
Figure 2. Tie downs on gillnet gear.	23
Figure 3. Beach seine	25
Figure 4. Beach anchored gillnet	25
Figure 5. Marked buoy.	27
Figure 6. Common anchor types.	27
Figure 7. Sighting area for protected species watches.	29
Figure 8. Common hook types.	33
Figure 9. Characteristics of a demersal longline gear.	35
Figure 10. Typical pot/trap trawl gear configuration.	41
Figure 11. Typical lobster trap configuration.	43
Figure 12. Red crab trap.	44
Figure 13. Hagfish pots showing escape vents.	45
Figure 14. Basic bottom otter trawl configuration.	50
Figure 15. Sections of netting in a trawl gear.	50
Figure 16. Trawl doors, ground cable, bridles, headrope, and footrope.	51
Figure 17. Blowout panels on a midwater trawl net.	51
Figure 18. Example of a separator device (Nordmore grate) and escape outlet.	53
Figure 19. Kite panels on a midwater trawl gear.	53
Figure 20. Twin trawls with nets connected (left) and not connected (right).	55
Figure 21. 4-seam single midwater trawl.	55
Figure 22. Small boats pair trawling in mid-water.	56
Figure 23. Examples of mid-water nets designed with large meshes (a) and parallel ropes (b).	56
Figure 24. Various configurations of midwater trawl net panels.	57
Figure 25. Pair trawl rigging designs showing bridles, warp, and boat relations.	57
Figure 26. Diamond (left) and square (right) meshes.	58
Figure 27. Vernier calipers.	59
Figure 28. Examples of sweep gear.	60
Figure 29. Flounder trawl configurations.	61
Figure 30. Haddock separator trawl	62
Figure 31. Ruhle trawl.	62
Figure 32. A large mesh belly panel installed in a bottom trawl.	63
Figure 33. A sweepless raised footrope trawl.	64
Figure 34. Parts of a purse seine.	68
Figure 35. A purse seine net being pursed closed.	71
Figure 36. New Bedford style scallop dredge.	76
Figure 37. Standard scallop dredge frame	77
Figure 38. Parts of a scallop dredge frame.	77
Figure 39. Turtle deflector scallop dredge.	78

Figure 40. Scallop dredge apron.....	79
Figure 41. Scallop dredge with turtle chain mat.	80
Figure 42. Scallop dredge with spider chain mat.	80
Figure 43. An example of stern-rigged dredges on A-frames.....	86
Figure 44. Example of nozzles on the manifold section of a clam/quahog dredge.....	86
Figure 45. Example of a tow line attached to a dredge.....	87
Figure 46. Examples of different sorting machines used on clam/quahog vessels.....	87
Figure 47. Safety concerns displayed on a clam/quahog vessel	88
Figure 48. An example of a one-piece (left) and two-piece (right) dredge.	89
Figure 49. An example of a conveyor system set up to fill a specific section of cages on deck.....	89
Figure 50. Cetacean body measurements and sampling locations.	96
Figure 51. Pinniped body measurements and sampling locations.	96
Figure 52. Additional measurements (straight line) for bottlenose dolphins.	97
Figure 53. Marine mammal in dead, fresh condition.	100
Figure 54. Marine mammal in dead, moderately decomposed condition.....	100
Figure 55. Marine mammal in dead, severely decomposed condition. Right: close up of head.	100
Figure 56. Sea turtle body measurements and sampling locations.	101
Figure 57. Measuring turtle carapace length, notch to tip.....	101
Figure 58. Measuring turtle carapace length, notch to notch.....	102
Figure 59. Measuring turtle carapace width.	102
Figure 60. Sea turtle dorsal view, showing vertebral and costal (lateral) scutes.....	102
Figure 61. Sea turtle ventral view, showing inframarginal scutes.....	103
Figure 62. Head of sea turtles, showing pre-frontal scales.	103
Figure 63. Sea turtle Inconel tag applicator.	106
Figure 64. Properly applied Inconel tags to the rear flippers of a live sea turtle.	106
Figure 65. Scanning sea turtle for PIT tags.	107
Figure 66. Proper positioning of sea turtle for resuscitation.	109
Figure 67. An example of multiple checker pen shapes present on deck.....	119
Figure 68. An example of how to break down irregularly-shaped areas	120
Figure 69. An example of scallop deckloading ending with catch on deck.	130
Figure 70. An example of scallop deckloading starting with catch on deck.....	130
Figure 71. Conveyor belt with checker pen (on right) and discard chute (on left).	131
Figure 72. Marel scale showing location of serial number.....	140
Figure 73. An example of the finfish Length Frequency Board and Length Frequency strip	148
Figure 74. Example of where to mark the Length Frequency strip for a Fork Length measurement.	148
Figure 75. Cutting through a fish head to remove otoliths.	149
Figure 76. Accessing otoliths by cutting through the ventral side of the fish	149
Figure 77. Necessary angle to cut various fish to remove otoliths.	149
Figure 78. Examples of otoliths from a variety of fish.....	149
Figure 79. Location to take scales from yellowtail flounder.	150

Figure 80. Parts of the monkfish illicium.	150
Figure 81. Location of the monkfish illicium.	150
Figure 82. Age structure envelope.	151
Figure 83. Tyvek tags.	152
Figure 84. Examples of how to measure scallop shell height.	153
Figure 85. An example of obtaining a scallop meat weight volumetric measure.	153
Figure 86. An example of how to measure clam/quahog shell width.	154
Figure 87. An example of how to obtain width measurements using the Whelk Sampling board.	154
Figure 88. Taking carapace length for lobsters.	155
Figure 89. Measuring the carapace width of a crab.	155
Figure 90. Difference in the apron shape of male and female crabs.	156
Figure 91. First set of swimmerets in a male (left) and female (right) lobster.	156
Figure 92. Female crab with eggs.	157
Figure 93. Female lobster with eggs.	157
Figure 94. Newly extruded lobster eggs.	158
Figure 95. Eyed lobster eggs.	158
Figure 96. Hatching lobster eggs.	159
Figure 97. Lobster eggs spent.	159
Figure 98. Examples of lobsters with shell disease.	160
Figure 99. Drawing showing which telson on a female lobster should be v-notched.	160
Figure 100. Examples of new (a) and old (b) v-notches.	161
Figure 101. Examples of lobster molt stage.	162
Figure 102. Lobster with regenerating claws.	162

Paperwork Reduction Act Statement

Information collected through the observer program will be used to: (1) monitor catch and bycatch; (2) understand the population status and trends of fish stocks and protected species, as well as the interactions between them; (3) determine the quantity and distribution of net benefits derived from living marine resources; (4) predict the biological, ecological, and economic impacts of existing management actions and proposed management options; and (5) ensure that the observer programs can safely and efficiently collect the information required for the previous four uses. In particular, the observer program provides information that is used in analyses that support the conservation and management of living marine resources and that are required under the Magnuson-Stevens Fishery Conservation and Management Act (MSA), the Endangered Species Act (ESA), the Marine Mammal Protection Act (MMPA), the National Environmental Policy Act (NEPA), the Regulatory Flexibility Act (RFA), Executive Order 12866 (EO 12866), and other applicable law. Most of the information collected by observers is obtained through “direct observation by an employee or agent of the sponsoring agency or through non-standardized oral communication in connection with such direct observations”.

Under the Paperwork Reduction Act (PRA) regulations at 5 C.F.R. 1320.3(h)(3), facts or opinions obtained through such observations and communications are not considered to be “information” subject to the PRA. The public reporting burden for responding to the questions that observers ask and that are subject to the PRA is estimated to average 74 minutes per trip, including the time for hearing and understanding the questions, searching existing data sources, gathering and maintaining the data needed, and completing and reviewing the collection of information. However, depending on the fishery and trip duration, the public reporting burden can range from 4-250 minutes per trip. Send comments regarding this burden estimate or any other aspect of this collection of information, including suggestions for reducing this burden, to: Amy Martins, National Marine Fisheries Service, Northeast Fisheries Science Center, Fisheries Sampling Branch, 166 Water Street, Woods Hole, MA 02543-1026. Providing the requested information is mandatory under regulations at 50 C.F.R. 600.746 for the safety questions and at 50 C.F.R. §600.725, §600.746, §648.11; 16 U.S.C. 1387 §118; 16 U.S.C. 1531 *et seq.*, 16 U.S.C. 742a §222 for the other questions. All information collected by observers will be kept confidential as required under Section 402(b) of the MSA (18 U.S.C. 1881a(b)) and regulations at 50 C.F.R. Part 600, Subpart E. Notwithstanding any other provision of the law, no person is required to respond to, nor shall any person be subject to a penalty for failure to comply with a collection of information subject to the requirements of the Paperwork Reduction Act, unless that collection of information displays a currently valid OMB Control Number. This is an approved information collection under OMB Control No. 0648-0593 through 10/31/2018.

Introduction

The National Marine Fisheries Service (NMFS) Northeast Fisheries Science Center (NEFSC) Fisheries Sampling Branch (FSB) collects, maintains, and distributes data for scientific and management purposes in the northwest Atlantic Ocean. FSB manages three separate but related observer programs: the Northeast Fisheries Observer Program (NEFOP), the Industry Funded Scallop (IFS) Observer Program, and the At Sea Monitoring (ASM) Program. For the purposes of this manual, “observers” refers to any observer/monitor working for the FSB.

In 2014, FSB trained and deployed over 190 observers, provided coverage on a variety of fisheries, and completed over 13,000 sea days. Observed trips are required under many of the region's fishery management plans or by other federal laws and authorities, including, Magnuson-Stevens Fishery Conservation and Management Act, Marine Mammal Protection Act, the Endangered Species Act, the and the Sustainable Fisheries Act.

The purpose of this guide is to provide FSB observers, as well as end users of NEFSC Observer Program data, with a detailed description of the observer data collection protocols. For each fishery, background information is provided as well as definitions, common gear configurations, suggestions for sampling methodologies, and unusual circumstances that may be encountered.

In addition to this manual, the [NEFSC Observer Data Entry Manual](#) provides detailed instructions for each data field collected, and the [NEFSC Observer On-Deck Manual](#) provides summaries and tables intended to enable observers to quickly determine the correct sampling protocols and methods while at sea.

This manual represents a revision of the data forms, collection procedures, and protocols described in the [1996 NEFSC Observer Program Manual](#). For documentation of other changes see [Documentation of changes made to the NEFSC Fisheries Observer Program Manuals, 2016](#).

Definitions

Common Acronyms

NOAA: National Oceanic and Atmospheric Administration

NEFSC: Northeast Fisheries Science Center

FSB: Fisheries Sampling Branch

NEFOP: Northeast Fisheries Observer Program

IFS: Industry Funded Scallop Observer Program

ASM: At Sea Monitoring Program

Terminology Used in This Manual

Observer: Any person required or authorized to be carried on a vessel for conservation and management purposes by regulations or permits under the Magnuson Act

Deployment: Period of time during which an observer is assigned to a single vessel with the intention of fishing. A single deployment may be comprised of one or more trips. A deployment begins when the observer boards a vessel with the intent to observe fishing activity and ends when the observer disembarks from the vessel.

Trip: Period of time between when a vessel leaves port with the intention of fishing and/or transiting to another port (“trip begin”) to when the vessel lands in a port after fishing and/or transiting (“trip end”); not necessarily the same port.

Trip Data: All paperwork, biological samples, and electronic data (including photo uploads) collected by an observer during any one observed trip aboard a commercial fishing vessel

Landings: Total amount of fish kept and sold. Reported via vessel tracking information to the Federal Government.

Bycatch: Species which are not targeted, but are still harvested. May result in discards.

Stock: A species, sub-species, geographical grouping, or other category of fish capable of management.

Pelagic: Refers to species that spend most of their lives swimming in the water column, with little contact or dependency on the bottom.

Groundfish: Species that spend most of their lives on or near the sea bottom.

Haul: The deployment and subsequent retrieval of fishing gear.

Benefits of Observing Commercial Fishing Trips

Sampling Catches at Sea

Landings from commercial fishing trips have been sampled in Northeast ports for more than 100 years. However, identifying the species and numbers of fish landed and sold in our ports is only part of the story. Managing fisheries and the effects of fishing on the ecosystem requires information not only about what is landed, but also about what is not landed. We also need to know when and where, and in some cases, how these fish are caught. The objectives of the Fisheries Sampling Branch are to collect operational fishing data, biological data, and economic data from the various fisheries. Additionally, in support of the Marine Mammal Protection Act and the Endangered Species Act, observers record interactions with protected and endangered species to ensure continued survival of these animals.

Estimating Takes of Protected Species

Marine mammals, sea turtles, and seabirds are protected under a variety of federal statutes intended to reduce the risk of harm to these animals by fishing and other human activities at sea. Chief among these

statutes are the Marine Mammal Protection Act and the Endangered Species Act. FSB monitors marine fisheries to identify those that take protected species and, if necessary, help develop ways to reduce these takes. [Note: the term “take” is defined in the Marine Mammal Protection Act as “to harass, hunt, capture, or kill, or attempt to harass, hunt, capture, or kill any marine mammal”. It has a similar meaning under the Endangered Species Act, which applies to all wild plants and animals, including those in the ocean.] Fisheries observers document each take of a protected species during a fishing trip, as well as other catch and discard information, when possible. Total takes of protected species can be estimated from the samples obtained on observed trips in a particular fishery, and expanded to the whole fleet.

Estimating Discard of Fishery Resources

Catches brought aboard fishing vessels are typically sorted by marketable species and sizes, and the rest of the catch is thrown back, or discarded. Discarding may occur for a number of reasons: species may be smaller or larger than the allowable legal size, species may have little or no market value, species may not legally be possessed (*e.g.*, marine mammals and protected fish species), or the vessel may have already caught its limit for the trip. To get an accurate picture of the status of a fish stock and the influence of fishing on the ecosystem, it is important to gather biological information not only about what and how much is removed from the ecosystem through landings, but also about what is discarded.

Accompanying fishermen on regular commercial trips is the most reliable method of acquiring data on the quantity and species composition of discards, as well as information on the specific reasons why animals are discarded, and under what conditions discarding occurs. With these data, it is possible to better understand the effects of fishing on the whole stock, and to better estimate the potential biological and economic benefits of changes in methods of managing the fishery such as minimum legal sizes and trip quotas for individual species.

Getting Biological Information about the Catch

Biological information forms the basis of what we know about fish population changes over time. Examples include weights, lengths, and ages of individual fish. These data are collected annually from fisheries-independent scientific surveys conducted by the Northeast Fisheries Science Center. Information about these scientific surveys can be found on the NEFSC Ecosystems Survey Branch website. The Fisheries Sampling Branch collects fisheries-dependent data from the discarded, as well as retained, portion of a vessel's catch. This allows scientists to characterize catch by species, size, age, gender, and frequency, and then use that information, in conjunction with data from other sources, to compile a picture of the entire population.

Monitoring Experiments and Experimental Fisheries

The fishing industry is always looking for methods to reduce the incidental catch of unwanted species, including protected species. Conducting and evaluating the performance of a novel or experimental gear is another responsibility of fisheries observer programs. Sometimes it is possible to reduce unintended catch during fishing operations by changing the way gear is constructed and/or used. To properly evaluate new gear types and methods, an experimental version must be tested under a variety of conditions likely to be encountered during a typical commercial trip. Testing not only demonstrates what effects are achieved, but also whether the gear can be safely and efficiently used.

Learning about the Economics of Fishing

Revenue data (*e.g.*, landed value) collected from fishermen and dealers in the ports provide the income side of the economic equation. However, data on the costs of fishing are equally important. Observers gather information from vessel owners and captains regarding the costs of items used on a trip (*e.g.*, ice, fuel, supplies, bait, and estimated vessel and gear damage). Observer data is combined with data from other sources, such as economic surveys developed by the NEFSC Social Sciences Branch. The intent of these studies is to better understand the economic health and efficiency of fishing. This information is extremely important in the fishery management process because it allows quantitative analyses of economic impacts of various management options. Federal rules require that the economic benefits of regulation exceed the costs of such measures. Net economic benefits to the nation comprise benefits and costs to the producers (*e.g.*, fishermen), and benefits and costs to the consumers. Fisheries observer programs provide an important source of contact with knowledgeable individuals in the industry best able to provide these data.

Measuring Gear Performance and Characteristics

When fishery observers are deployed aboard commercial vessels, they take measurements of various attributes of the fishing gear, including how it is rigged and deployed. These measurements are important for two reasons. First: by documenting variables such as mesh size, number of hooks, time of trawl tow, hanging dimension (*e.g.*, square vs. diamond mesh) etc., in relation to catch attributes (*e.g.*, quantity, species composition, size distribution of catch), it is possible to conduct statistical analyses of the factors that result in high (or low) rates of discard, species mix, changes in catch rate, etc. Second: gear performance observations, when collected over time, can be used to better calibrate catch-per-unit-effort abundance measures. For example, if the average size of nets, duration of tow, etc., change over time, these may have a direct effect on catch per day fished by the fleet (even for same sized vessels). Given sufficient information, these factors can be included in stock assessment analyses to provide a more complete and accurate picture of fishing intensity and effectiveness.

Keeping up with Fishermen

The fisheries observer programs have always provided an excellent channel for communication between fishermen and fishery scientists. In the 1970s and 1980s, some scientists went along on commercial trips for specific experiments or simply to obtain first-hand knowledge of fishing operations. Although valuable to the scientists, the resulting data came from only a few dozen trips in a year. Today's observer programs are larger and more comprehensive in both the frequency of trips and the types of data collected. The programs remain an important link between scientists and fishermen. Ideas, complaints, and information communicated between observer, captain, and crew are a valuable source of information for all parties.

The fisheries observer program is a proven, valuable source of detailed information on the region's fisheries, unobtainable by any other means. Data acquired by this program have been important in identifying the species and size selectivity of several marine fisheries in the Northeast, and in reducing bycatch of protected species. Furthermore, these data have improved biological and economic assessments of the region's fisheries.

The cooperation of vessel owners, captains, and crew in taking observers onboard and supporting their data collection is instrumental in the success of this program. Most recognize that the goal of the program is to provide managers with the data needed to ensure a sustainable fishery for generations to come.

Observer Safety

Background Information

Commercial fishing is an inherently dangerous occupation, which is why observer safety is the number one priority of the Northeast Fisheries Observer Program (NEFOP). The safety training that you receive is invaluable and is intended to increase preparedness and competency and reduce reaction time during an emergency situation while at sea. In addition to training, you are encouraged to use the experience of your fellow observers and staff as a resource for safety issues. The knowledge and experience of the vessel's captain and crew can also be used for guidance on safety onboard their vessel. However, no matter how cautious the crew is, it is ***always your responsibility*** to keep yourself safe and know how to react properly in an emergency.

Be Prepared Even Before You Leave the Dock

At Home:

Before every deployment, you should monitor the NOAA weather forecast and buoy reports. Forecasts are predictions and may change, while buoy reports are the actual conditions recorded at buoy locations. Forecasts can be checked via weather radio or online. If you are unsure about what weather conditions are safe for a particular vessel, consult with local observers, your provider staff (area coordinators) and/or NEFOP staff (area leads).

You can access NOAA forecasts and buoy reports from:

<http://www.nws.noaa.gov/om/marine/home.htm>

First Aid and CPR

All FSB-certified observers are required to have current American Red Cross first-aid and CPR certificates and to review first-aid and CPR procedures regularly. It is recommended to bring a personal first-aid kit, in addition to all personal health items (medications, prescriptions, etc.) with you when are deployed to a vessel.

You must also maintain your personal survival gear. This entails testing the battery in your Personal Locator Beacon (PLB) on a monthly basis (refer to the owner's manual that you were issued with your PLB), inspecting your immersion suit and personal floatation device (PFD) for wear and tear, waxing your immersion suit zipper, and making sure that all immersion suit attachments (PLB, mirror, whistle and strobe) are untangled and in working order.

It is also important to be well rested and have clear directions for the time and location where you will be meeting the vessel. Long and/or late hours, the environment, the food, and the activities while onboard may be quite different from what your body is accustomed to. Two critically important factors in maintaining health in this environment are drinking plenty of water and eating enough food.

At the Dock:

FSB requires that you wear a PFD any time you embark or disembark a vessel. It is common to see vessels rafted (tied) to one another two or more deep in docking areas. ***Boarding vessels that are tied to the dock or are rafted is extremely dangerous!*** Falling between the dock and the vessel, or between one vessel and another, can result in serious injury or death. The distance between the vessel and the dock or between

vessels that are rafted can vary widely with the weather, tides and currents. To enhance your safety when boarding vessels:

- Always wear a PFD when crossing between boats and the dock.
- Notify someone on the vessel that you are about to board and/or disembark.
- Consider conditions such as icy and slippery decks and/or ladders, poor weather, darkness, wind, tides, currents and/or greater distances than you can manage.
- Do not try to carry all gear and luggage onboard at once. Balance is important and both your hands should be free while boarding or leaving a vessel. Ask for assistance from the crew when loading and unloading your gear.

Onboard:

Pre-Trip Vessel Safety Checklist

Federal law states that you receive a safety orientation when you board a vessel. During the safety orientation, you are mandated to check the vessel for specific safety items. This requirement is fulfilled by completing the Pre-Trip Vessel Safety Checklist (PTVSC). The PTVSC is a comprehensive list which includes all the safety items required by U.S. Coast Guard regulations that must be verified prior to departing on a trip. A copy of the most current PTVSC, as well as instructions for how to complete the fields, is located in the NEFSC Observer Data Entry Manual. These items must be current (not expired) and in working order:

- U.S. Coast Guard Commercial Fishing Vessel Safety Examination decal or certificate of compliance
- Emergency Position Indication Radio Beacon (EPIRB)
- Survival craft (with sufficient capacity for everyone onboard, including the observer)
- Signaling devices (flares)
- Fire extinguishers
- Immersion suits/PFDs
- Throwable flotation devices

During the orientation, it is also important to ask the captain or crew for a safe location to store your gear and conduct sampling duties. In addition, pay attention to the overall condition of the vessel. Refer to Vessel Orientation Guide for a broad list of conditions and/or things to consider when doing the vessel walk through.

Once the PTVSC is completed, continue to be aware of all the potential hazards while out on deck, including fishing gear (e.g., warps under tension, overhead blocks, net ramps, winches), hatch openings, and slick areas.

Always practice situational awareness! Any safety concerns should be recorded on the PTVSC and discussed with your area coordinator or FSB staff prior to departing on the trip.

If any of the items on the PTVSC are missing, not adequate, or expired, then by federal regulations you cannot deploy on the trip and must conduct NEFOP's Safety Deficiency Reporting (SDR) procedures. The SDR procedures are as follows:

- Fill out two copies of the NOAA Office of Law Enforcement (OLE) letter. Give one copy to the captain or vessel owner and mail in the other copy along with a completed copy of the PTVSC to FSB.

- Complete an Incident Report form online, which can be found on the FSB website, and submit it electronically.

If you cannot verify the safety requirements because of personal safety concerns (e.g., hazardous weather conditions), contact your provider and do not depart on the trip. Be aware that certain items on the safety checklist may not be required for vessels of certain sizes or vessels operating in certain geographic areas. For further information, refer to the U.S. Coast Guard publication “Federal Requirements for Commercial Fishing Industry Vessels,” or contact FSB area lead staff.

Vessel Orientation Guide

The following is a list of examples of important things to consider while doing a vessel walk through. It is a requirement for the captain or a designated crew member to conduct at least one of the following for an observer:

1. vessel orientation,
2. review safety instructions, or
3. conduct a safety drill.

The following list should assist you in determining the relative safety of a particular vessel. The list is not comprehensive, but one that is intended to start you thinking.

- Does the vessel seem well maintained? Is it neat, clean and being maintained by a careful and prepared crew?
- Are there any visible hydraulic leaks?
- Is the vessel being used for the purpose it was originally designed? Have significant changes been made?
- Do obvious hazards exist? Note potentially hazardous areas/conditions. ALWAYS USE CAUTION AROUND WINCHES.
- Identify water tight doors. Can they be secured in case of severe weather or emergencies?
- Are the hatches or passageways blocked or difficult to get to?
- Does the deck gear appear to be in good working condition? Identify unsafe areas. Note overhead wires or rusted/worn shackles or blocks.
- Is the vessel long overdue for a haul out (excessive growth at waterline or hull paint in poor condition)?
- How often is the bilge pump going on?
- How is the fish hold covered? Is hatch readily available and in good condition? Are there other openings in the deck and are good hatches in place or readily available?
- Would anything prevent you from abandoning ship from the living quarters?
- What are the escape routes from every part of the vessel you might find yourself?
- Visualize egress for all possible scenarios (fire, flooding, capsized, dark, etc.) and mentally note landmarks.
- What are the most combustible items onboard and where are they stored?
- Are there any exposed exhaust pipes/manifolds that might pose burn hazards?

- Is there heavy equipment on deck that is not latched down?
- Are there any exposed drive chains, pulleys or belts?
- Would you be able to access the life raft if conditions were icy or the wheelhouse was on fire?
- Wood hulls: Rust stains between planks?(may indicate weak fasteners). Protruding planks or inconsistencies in the hull? (may indicate broken frame/fasteners). Wood rot present? (if yes, likely to be worse in unseen areas).
- Are there safety issues involved with boarding?
- Is the number and size of the scuppers sufficient to be effective? Do they become plugged during fishing practices?
- Is there a station bill posted and is your role clear during all shipboard emergencies?
- Are there emergency instructions, or did the captain (or designee) give safety orientation, explaining the following: survival craft embarkation stations; survival craft assignments; fire/emergency/abandon ship signals; procedures for rough weather; procedures for recovering man overboard; procedures for fighting fire; essential actions required of each person in an emergency?

Emergencies at Sea

The U.S. Coast Guard should be contacted during and/or after any type of marine casualty or accident, even if the situation seems manageable or under control. This includes serious injuries or loss of life of any person, any occurrence involving a vessel which results in damage by or to the vessel, including its gear or cargo, collisions, groundings, strandings, foundering, heavy weather damage, fire, flooding, explosions, failure of gear and equipment, and any other damage which might affect or impair the seaworthiness of the vessel. Familiarize yourself with your role, and be aware of crew roles as indicated on the vessel station bill.

Illness and Accidents

If you become ill or injured while onboard a vessel, you should notify the captain of your condition and make notes about it in your field diary, especially if the injury or illness inhibits your job duties. When an injury, illness or ailment cannot be treated and pain or symptoms worsen or become unbearable, i.e., a medical emergency, the U.S. Coast Guard and your provider should be contacted. If you are in doubt about the seriousness of your situation, contact your provider for guidance.

- U.S. Coast Guard District 1 ME-NY (RCC Boston) [617-223-8555](tel:617-223-8555)
- U.S. Coast Guard District 5 NJ-NC (RCC Norfolk) [757-398-6390](tel:757-398-6390)
- If no phone service (cell phone or satellite phone), contact the U.S. Coast Guard via VHF radio (channel 16)

Sending a Mayday

A Mayday call is an emergency procedure used in situations of grave and imminent threat requiring immediate assistance. You should be familiar with the components of making a Mayday as you may be the person initiating the call in an emergency situation.

- Select channel 16 on the VHF radio
- MAYDAY MAYDAY MAYDAY (say three times)

- Vessel name
- Location
- Nature of the emergency
- How many people onboard
- Vessel description

Listen for a response. If there is none, repeat the message until it is acknowledged or you are forced to abandon ship.

Man Overboard

Everyone has an active role in a man overboard emergency. If you witness someone falling over, you must both notify the person operating the vessel and keep the victim in sight. Keep your eyes on and your arm pointing to the victim. Other duties that you can perform include throwing floating objects in the direction of the victim, readying equipment for a rescue swimmer and treating the victim for hypothermia or any injuries once recovered onboard. If you fall overboard, attract attention by yelling or using your whistle, assume the heat escape lessening position (H.E.L.P.), keep clothes and boots on (as they will increase your insulation and will not pull you down), grab any floating objects, and stay as still as you can.

Fire

If you are the person to discover a fire or indications of a fire, immediately sound an alarm and give the exact location of the fire. Additional duties that you can perform include gathering fire-fighting equipment (fire extinguishers, deck hoses), gathering survival gear, and providing communication. Your role is primarily to assist as needed.

Flooding

When a vessel is taking on water, the crew usually has time to try and stop or slow the problem. You can assist by locating damage control materials, closing weather and watertight doors and hatches, and being prepared for assistance with a dewatering pump. If the vessel is not equipped with a dewatering pump, a Mayday call should be made to the U.S. Coast Guard, as they can deliver a pump(s) from the air to the vessel. If need be, the pump will be delivered in a watertight, floatable container, along with gas and a detailed diagram of instructions on how to operate the pump. Your role is primarily to assist as needed.

Abandon Ship

When the call is made to abandon ship, you should use whatever time is available to:

- Activate your PLB.
- Prepare the life raft for launching.
 - Release the life raft canister from the cradle, and tie off the painter line to a secure point on the vessel.
 - Toss the life raft canister into the water, and pull the painter line until the raft inflates.
- Don immersion suit (or PFD, if immersion suit is not accessible).
- If possible, board the raft without getting wet. You can jump directly into the canopy opening or lower yourself with a ladder, net or line.

Notes

Trip Overview

Trip Selection

Call-in Fisheries

For some fisheries, vessels are required to notify the observer program before a trip. Depending on the fishery, a selection algorithm is used to determine whether an observer is required for that trip or not. For selected trips, your observer provider should give you: vessel information, expected date and port of departure, expected trip duration, fishery, and any additional details. In most cases, you will be expected to confirm this information with the captain or vessel owner prior to sailing. Vessels selected for observer coverage cannot sail without an observer.

Solicitation

For fisheries without pre-trip notification requirements, a trip may be directly solicited by the observer or observer provider. A selection letter should be given to the captain or vessel owner, notifying them of the observer coverage requirement. Vessels selected for observer coverage cannot sail without an observer. Typically these trips are selected based on the NEFOP Seaday Schedule, which prioritizes available funded seadays to strata (defined by gear, mesh size, and area) to achieve the required scientific precision for bycatch analysis.

Preparing for a Trip

Regardless of the trip selection method, you should confirm the trip details with the captain, and plan to arrive at the dock at least one hour before the intended sail time. Depending on the trip type, you may also be required to contact FSB for a pre-brief – a set of instructions/reminders for a particular fishery.

What to pack

On a typical trip, you might bring:

- Safety Gear
 - Personal Locator Beacon (PLB)
 - Personal Flotation Device (PFD)
 - Immersion suit with strobe, whistle, and signaling mirror
 - Portable life raft, if vessel life raft capacity is insufficient
- Foul Weather Gear
 - Jacket
 - Bibs
 - Gloves
 - Boots
 - Safety knife
- Catch Sampling Gear
 - Wrist watch
 - 5-gallon buckets
 - Orange bushel baskets
 - Depth stick for measuring volumes

- 12-lb and 100-lb spring scales
- Digital scale
- Calipers
- 10-ft and 50-ft measuring tapes
- Biological Sampling Gear
 - Tags and tagging equipment (pliers, zip-ties)
 - Knives
 - Biopsy punches
 - Forceps
 - Storage (vials, envelopes, bags)
 - Waterproof slates and worksheets
 - PIT Tag Scanner (turtles)
 - Length frequency board and strips
 - Temperature probe
 - Pinger Tester (gillnet trips)
 - Disposable backup camera
- Electronics
 - Electronic tablet (running Android OS) with charger
 - Digital camera with charger
- Guides and reference material
 - 2016 NEFSC Observer Operations Manual
 - 2016 NEFSC Observer Data Entry Manual
 - 2016 NEFSC Observer On Deck Reference Guide
 - Field identification guides
 - Regulatory compliance folder
 - Field diaries
 - Waterproof notebooks
- Personal Items
 - Clothes
 - Toiletries, including sunscreen, chap stick, and hand sanitizer
 - Sleeping bag
 - Music/DVD player
 - Snacks
 - Medications
 - Personal first aid kit
 - Flashlight
 - Closed toed boat shoes
 - On multiday trips: pillow, towel, and fitted bedsheet

Before the First Haul

You may not board the vessel before the captain has arrived. Introduce yourself to the captain and any crew members present, and then begin your Pre-Trip Vessel Safety Checklist. Make sure you know where all the safety equipment is and that the equipment is up to date. Stow your gear, keeping your immersion suit in a place that is easily accessible in case of an emergency.

The captain and crew will likely be busy while navigating out of the harbor. Be aware of this, and wait until an appropriate time before asking questions. Explain your duties as an observer, even if you have been on a particular vessel before. It is important to discuss factors such as sampling station location and what your responsibilities are in the case of an incidental take.

You should confirm pertinent vessel information such as permit and hull numbers, and fleet/sector associations. You will need to know what gear the captain intends to fish, as well as which species will be targeted. Review your data logs to find any other data fields that can be collected at the beginning of the trip.

Ideal Sampling Stations

The establishment of a proper sampling station is the foundation for effective and accurate sampling. The criteria for a good sampling station is one where you are safe, reasonably out of the way of the crew's operations, and can still have a good view point of all operations on deck. Since an observer's presence is not required on every trip, finding the best sampling station will often require some compromise between you and the crew. If you are new to observing multi-day trips, it is recommended that you take the first haul of the trip off, as an opportunity to observe how operations on this vessel will be conducted. This will facilitate the process of choosing an appropriate sampling station. You must have access to the catch (kept and discarded species) as well as have a clear and unobstructed view of the crew's operations.

When establishing the sampling station you must determine:

- What sample type and size to collect.
- Where to collect the sample.
- What sampling biases could occur in the collection process, and how to minimize said biases.
- How to collect the sample.
- How to work up the sample.

In some fisheries, it may be in the vessel's interest to discard species prior to you having a chance to take samples. This may be the case when dealing with protected species or strict Total Allowable Catch (TAC). This behavior creates biases within the data, and does not accurately represent the catch you are there to observe. It is your responsibility to educate the captain and crew of each vessel about what your job entails, and to remind them of these responsibilities if such interference occurs. If the interference continues, this activity must be documented in the field diary. You must be present during the sorting of the catch to ensure the sample is unbiased.

For all trips, you will need:

- Access to discarded species.
- An area for the length board to rest on.
- Access to your personal bucket or basket for weighing purposes.

Gillnet

- The ability to view the catch as it is brought onboard.
- A view of hauler (for pelagic species and incidental takes).

- The ability to view catch if it is shaken out of gear before coming on board.

Trawl

- The ability to view the entire contents of the catch pile.
- Access to measure the checker pen.
- The ability to take samples from the checker pen or conveyor chute.

Dredge

- The ability to view the entire contents of the catch pile.
- Access to measure the catch pile(s).
- The ability to take samples from the catch pile(s).

Longline/Handline/Autojig

- The ability to view hauler/crucifier that is not in the way should the captain/crew need to suddenly gaff fallen catch.
- An area that will have plenty of room to weight/measure catch (day longline boats are small).
- Access to catch (usually the crew will stand behind the captain at the hauler and dress fish immediately after it comes onboard).

Determining kept vs. discard

It is always the captain or crew that should be deciding if an animal is kept or discarded. Even if you think you know the size regulations, do not make those determinations yourself. Regulations can change overnight, or the vessel may be fishing under a exemption. Your job is to accurately record what the crew is doing; when you do the crew's job, you may be inadvertently introducing bias.

During/After Each Haul

Follow Sampling Priorities

The 2016 NEFSC Observer On Deck Reference Guide (ODRG) contains detailed sampling priorities for each fishery. In general, on each observed haul you will:

- Obtain haul information:
 - Which gear was fished
 - Time gear was set out, fished, and retrieved onboard (varies by fishery)
 - Environmental conditions (e.g., depth, weather; varies by program)
 - Condition of the gear that may affect catch rates
- Quantify the catch:
 - Determine which estimation method(s) or strategy you will employ.
 - Get actual weights on priority discards whenever possible:
 - ASM: groundfish
 - IFS: flatfish, scallops
 - NEFOP: groundfish, commercially important species, target species

Environmental data

In the 2015 NEFSC Strategic Plan (<http://www.nefsc.noaa.gov/rcb/stratplan>), Ecosystem Based Fisheries Management was identified as a core focus, including incorporating environmental data into fisheries stock assessments. Observers provide fine scale, location-specific environmental data, which can be used in conjunction with large scale tools, such as weather buoys and satellite data.

- Get actual weights or estimates on non-priority discards.
 - Bycatch like skates, dogfish, and crustaceans can be estimated via tally counts or subsampling.
 - Discards such as debris, sponges, empty shells, and starfish can be visually estimated.
- Get actual weights or estimates on kept catch.
 - Most of the time, kept catch will be sorted into totes or baskets, making it easy for you to use the basket count method.
 - If catch is being put directly into the hold, your only option may be to get an estimate from the captain. Be sure to ask if the captain's estimates are in round or dressed pounds.
- Take any required photographs for species verification. See the ODRG for the most recent Species Verification Program guidelines, and any additional fishery-specific requirements.
- Follow biological sampling requirements listed in the ODRG for the fishery and area you are observing. This may include length frequencies, age structures, shell heights, meat weights, and crustacean sampling.
- If an IAL species is present:
 - Photograph for identification.
 - On smaller animals, obtain an actual weight. On larger animals, use a visual or captain's estimate for the weight.
 - Take required length(s), if safe to do so, or estimate the length. Length types for each species are listed in the ODRG.
- If an incidental take occurs:
 - Follow minimum sampling priorities listed in the ODRG.
 - ASM: Incidental takes should not interfere with your catch sampling (i.e., the haul should still be observed).
 - NEFOP and IFS: The incidental take becomes your top priority (i.e., the haul may be unobserved).
- If a discarding event occurs:
 - Determine the reason (gear damage, mechanical malfunction, non-desired species).
 - Estimate the weight; typically a combination of observer and captain.
 - Record species composition as best as you can, to species group if needed (e.g., "herring-like fish").
 - A discarding event will generally result in an unobserved haul, but you should still record as much detail as possible.

Entering your data into logs and/or entry software can be time consuming, especially on multiday trips. It is recommended that you do as much as possible during the trip. This makes data transmission faster once you land, and can help you catch errors while you still have an opportunity to correct them.

Geographical and Statistical Areas

Almost all commercial fishing operations take place within the Exclusive Economic Zone (EEZ) of the U.S., a boundary to foreign fishing fleets approximately 200 nm from the coast line. In parts of the Gulf of Maine

where the EEZs of the U.S. and Canada would overlap, the Hague Line was created to define each country's proprietary waters.

Statistical areas are used to define particular habitat strata throughout the Northeast Region. It is important to be able to determine which statistical area fishing is taking place in, as that can affect the sampling priorities. It can also be used to assign catch rates to particular stocks, depending on the species. Statistical area can be determined once the geographical position is known. Most vessels will have GPS units in the wheelhouse for navigation, or you may use a NMFS-issued GPS device.

Definitions

Marine Protected Areas: National marine sanctuaries, national parks and wildlife refuges, many state parks and conservation areas, and a variety of fishery management closures.

Closed Areas and Exemption Areas: Highly productive habitats that have been closed completely or have restrictions with regards to fishing access.

Special Management Program (SMP): Management schemes which allow fishing to occur in Closed Areas, Exemption Areas, and Essential Fish Habitats with set and regulated TAC and/or a bycatch TAC.

Scallop Access Areas: Closed areas that allow fishing for scallops that have a scallop TAC; some areas have additional restrictions with yellowtail flounder TAC.

Restricted Gear Areas & Regulated Mesh Areas: Exemption areas that allow fishing for a specific species with specific gear characterizations.

Rotational Closures: Areas that are open part of the year and closed part of the year according to a rotational schedule. Designed to assist in the recovery of or prevent the depletion of strategic marine mammal stocks that interact with Category I and II fisheries

U.S./Canada Management Area: Four statistical areas within the U.S. EEZ where Canadian fishing vessels are permitted to fish. Catches in this area are shared amongst both countries, and access is restricted to certain fisheries and times of year.

At the End of the Trip

During the steam in, you should make sure you have gotten all the information from the captain that you need. This is a good time to follow-up with any unclear disposition reasons, confirm any remaining gear characteristics, and ask questions about final trip costs.

As a program requirement, you must offer the captain the opportunity to provide feedback to FSB via comment cards/logs and to obtain a copy of their data via a data release. Some captains are very involved with the data collection and will use these on every trip; others are not interested and may refuse to take them.

Do not share observer data

All data you collect on observed trips are confidential; you cannot share it with others. This includes any media taken (e.g., photos, videos, voice recordings). You should also avoid talking about one fisherman's data while on another's boat.

When you land, enter any remaining data onto your logs and/or entry software and review for errors. Submit your electronic and hard copy data following your program deadlines. Much of your data is used near-real time, and late data can have significant effects on fisheries operations. If you think you will need more time, contact your provider as soon as possible; they can request an extension from FSB.

What happens to your data

Electronic trips are reviewed (edited) and debriefed (if necessary) the same day they are received. After this preliminary review, data are made available to end-users and sector managers (for groundfish data). Once the paper logs arrive, an editor will review all data, compare to the electronic upload for correctness, and debrief you as necessary.

Editors check every field on each log on the trip to verify that all fields are formatted correctly and fall within the expected range of values. Unexpected values are investigated via debriefing(s), comparison with similar trips (by vessel, gear, and/or area), and comparison with other data sources (*e.g.*, Vessel Trip Reports, dealer reports, vessel tracking positions). All missing entries and unknown values are confirmed. Any calculations used to estimate species weights and methodologies are verified. All media submitted with the trip will be reviewed and used to verify gear configuration, catch estimation, and species identification. All biological samples are checked against the paper data, before being submitted to other branches for processing and analysis (*e.g.*, Age and Growth lab for age structures, Protected Species Branch for incidental takes).

Data not collected electronically are key-punched into a computer entry system, and a thorough audit is completed before loading to the master database. From there, data end users at the NEFSC perform analyses related to stock assessments, bycatch and discard rates, protected species interactions, and sea day requirements, among others. Users outside the NEFSC can request direct access (*e.g.*, Council staff) or aggregated data (*e.g.*, universities, non-governmental organizations). Vessel captains and owners can also request complete copies of trip data at any time.

Aborted/Broken/Transit Trips

Occasionally, a vessel may return to dock before or after beginning fishing activity, for various reasons (weather, gear malfunction, crew member injury, etc.). How you record those trips will depend on the exact scenario, and may differ from the broad guidelines described here. When in doubt, contact FSB staff for guidance. In all cases, the trip must be accounted for (*i.e.*, given a unique trip identifier and submitted according to protocol).

Aborted trip: When the vessel leaves port with the intention to fish, but the gear is not used (set, hauled, or washed), regardless of time on the water. Aborted trips will have no haul or catch data associated with them, but you will have to collect trip costs. If you are still assigned to the vessel when they resume fishing, the trips may be submitted together as one deployment.

Transit trip: When the vessel leaves port with no intention to fish, but travels to another port with no fishing activity in between. Reasons for doing this include picking up ice or a crew member in another port. Travel between docks within the same port do not constitute a transit trip. Each transit trip must be numbered and

submitted separately, typically as part of a deployment with one or more fished trips. Trip costs are not collected on transit trips.

Broken trip: When the vessel begins fishing activity, and then returns to the dock with the intention of returning to fish again before offloading catch. The most common scenario is a vessel coming in due to hazardous weather conditions; they may return to their home port or a sheltered port nearer to the fishing grounds. The first trip ends when the vessel lands in any port; if you stay with the vessel when they resume fishing activity, the second trip will be considered part of the same deployment.

Some of your duties only have to be performed once per deployment:

- Safety checklist and walkthrough¹
- Explanation of duties
- Gear measurements¹
- Offering comment cards and data release forms
- Biological sampling requirements must be met for the deployment; in other words, you do not have to start at '0' when fishing resumes after a broken trip.

You may also encounter *time lost* from fishing activity while at sea. This can be due to weather conditions (e.g., waiting out a storm at sea), gear damage repair, or Coast Guard boardings. Repairs due to normal wear and tear of fishing gear are not considered time lost. Follow your program guidelines for documenting these occurrences (see [2016 NEFSC Observer Data Entry Manual](#) for specifics).

Communication and Conflict Resolution

The captain commands the vessel and everyone onboard. Captains accept this role and expect the respect that goes with it. Crew members follow the commands of the captain. You, as an observer, are not a crew member. However, you follow the commands of the captain, especially as related to safety; Keep in mind that the job requires independent collection of data and information following specific guidelines.

Increasingly over the years, regulations have limited captains' abilities to fish exactly when, where, and how they want, while also requiring them to report. You must balance respecting the captain's job and doing your job. These can be in conflict. For example, you must record a marine mammal incidental take but the captain may not want to delay fishing to do so. You represent the Federal Government, and your data must be collected according to uniform methods and procedures. Good communication can help mitigate the potential conflicts between your observer duties and the fishermen's interests. At all times, respect the boundaries between observer and fisherman, and do your best to not let a dispute escalate. Many times it is best to back down from a conflict, rather than try to win the argument.

¹ Although the full Safety Checklist is only required once per deployment, if you leave the vessel for any reason between trips, you should ensure that no safety equipment has been removed or modified before going to sea again. Similarly for gear configuration, you should confirm with the captain that the net/dredge has not been altered or switched out.

The vessel design and fishing activities increase the possibility of disputes; normal communication methods may not work easily. These are some factors that may make communication difficult:

- Time pressure: Catching the tide, loading and offloading the vessel, leaving and arriving at the port, selling to market at a high price
- Limited space: Bumping into others, person in the way, cannot see around vessel
- Fatigue: Fishermen and observer may be working long hours and may be irritable, unsafe
- Noise: Cannot hear or be heard over engines; many fishermen have hearing damage
- Smells: Smoke, diesel, fish, decomposing marine mammal takes, bothersome body odor
- Visibility: Fog, ocean spray, nets = cannot see instructional gestures or what is happening
- Language: Fishing jargon and foreign language inhibit communication

If a dispute situation is escalating, drugs or weapons are involved, or if there is a bully, you must decide on the safest way to proceed. If methods to date have not worked, even though it can be difficult, it may be necessary to request that a vessel go to port, or to call for assistance.

At all times there is the possibility of a person being hurt, equipment failing, seas becoming rough, and vessels being damaged. You have a job to do, but you must also be mindful of safety and compromise as needed.

You will probably be unable to ask questions or obtain advice from your observer provider or NMFS once you are at sea. This must be done prior to leaving the dock, and if problems are unresolved, consider not making the trip. Available to you are: your regional lead, editor, trainers, OLE, and provider. The reference materials provided to you will assist in answering questions that may arise.

Practices on one vessel will not necessarily be successful on another vessel. There is an onboard culture that may differ from vessel to vessel. It will take time (that may not be available) to “fit in.”

Although efforts have been made to prepare you for all types of circumstances, there may be situations where you must choose the best course of action to be safe and still provide accurate, unbiased data. You answer to the captain, your provider, NMFS (staff, editor, enforcement), federal regulations and laws, Coast Guard (when boards/directs), yourself and the weather.

You need to be able to identify the line between: safe & unsafe, ranting & abuse, complaining & refusal.

Notes

Gillnet and Beach Seine Fisheries

Definitions

Gillnet: One net, or a series of nets (a.k.a. panels, bundles or shots), tied together (a.k.a. “the string”), made of monofilament nylon stretched between a weighted leadline and floatline creating a vertical barrier of netting in the water column (see Figure 1).

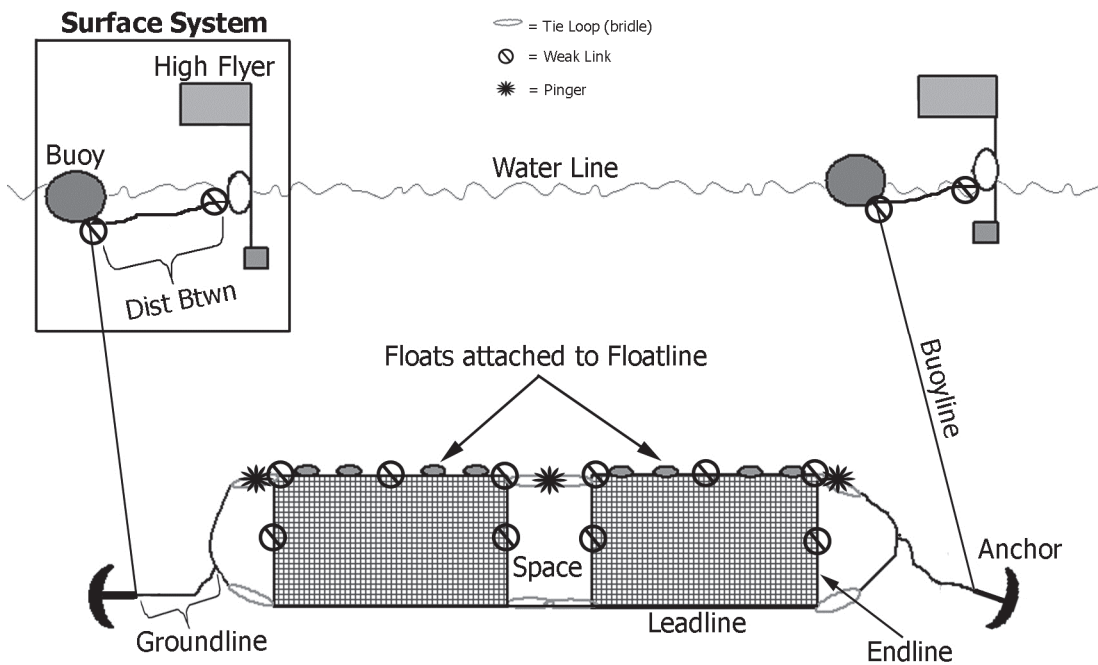

Figure 1. Anchored sink gillnet typical configuration.

Net length: Horizontal distance of a single net measured along the floatline.

Net height: Vertical distance of the line at the end of a net where the meshes are attached. Also called “frame,” “up and down,” or “endline” height of net.

Hanging ratio: Proportion of the length of the floatline for one net to the length that net would be if it was taken off the floatline and stretched out to its full capacity (i.e., how tightly the mesh is stretched horizontally along the floatline).

Floatline: Line along the top of the gillnet frame, typically composed of either polypropylene or buoyant foam core center.

Leadline: Weighted line along the bottom of a gillnet frame.

Tiedown: Vertical line that connects the floatline and leadline as a way to create a pocket or bag of netting. The tiedown length is the working height

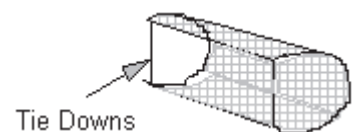

Figure 2. Tie downs on gillnet gear.

of the net, not to be confused with the net height (see Figure 2).

Space: A space greater than or equal to 2.5 feet between nets, continuous from the floatline to the leadline. This space may be caused by the way in which the net bridles are attached.

Bridles: The trailing ends of the floatline and leadline on an individual net, used to tie together individual net panels in a string, or attach anchors, groundlines, or buoylines.

Dropline: A line that connects floats on the water's surface to the floatline along the entire string with the purpose to suspend the gear at the desired depth in the water column. In areas with high recreational boating, droplines may also be placed along the string for visibility.

Active Marine Mammal Deterrent Device (MMDD): A device which emits a sound detectable by marine mammals to aid in detecting gillnet gear and avoid entanglement, referred to as "pingers."

Passive Marine Mammal Deterrent Device (MMDD): A device which provides a reflection of echolocation signals which allow marine mammals to detect gillnet gear and avoid entanglement.

Surface system: The configuration of high flyers and buoys and/or floats at the surface of the water that marks the gear (see Figure 1).

Buoyline: A line that connects the surface system to the gear (anchor or net) fishing in the water below. A line that connects the gear to the vessel is not considered a buoyline.

Groundline: A line that connects a gillnet, or gillnet bridle, to an anchor. If no anchor is used, there is no groundline.

Weak link: A breakable component of gear that will part when subjected to a certain tension load. Can also be called a "break-away."

Anchor vs drift:

An *anchored* gillnet uses a burying type of anchor (e.g., Danforth-style), or deadweight (e.g., railroad tie, battleship chain, cement blocks), to hold the gear in place.

A *drift* net does not use anchors, and may move freely with the water currents. A net with only a heavy leadline and/or sash weights is not considered anchored.

Sink vs float:

A *sink* net is set on the sea floor and targets demersal and semi-pelagic fish species.

Float gillnets can be fished anywhere within the water column, typically at or near the water's surface. If a net covers the entire water column, the categorization is determined by whether the net would sink or float in deeper water

Beach Seine: A vertical hanging net set from, and anchored to, the beach (see Figure 3). Sometimes incorrectly referred to as a haul seine.

Beach Anchored Gillnet: A vertical hanging net set from, and anchored to, the beach (see Figure 4).

Bunt: A short section (approximately 30ft) of twisted multifilament nylon. This section is located on the beach end of a beach seine net and is intended to trap fish, without gilling, so that they can be hauled up onto the beach.

Wash Net: A short section (approximately 10ft) of monofilament gillnet attached on the beach end of a beach seine net. This net is generally heavier twine and larger mesh than what is used in the wing. The intent of this net is to allow debris caught in the surf zone to pass through without being caught.

Wing: The main component of a beach seine net. It is a monofilament nylon gillnet. One, two, or more nets can be used in the wing. Fish can be gillnet in the wing or it can be hauled in such as manner as to corral the fish.

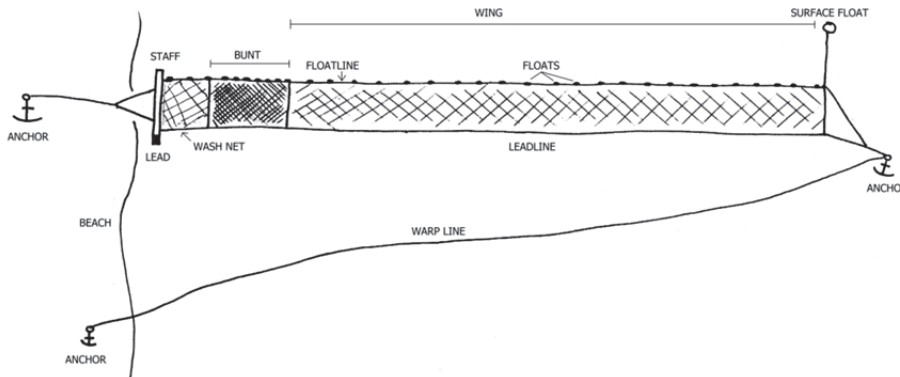

Figure 3. Beach seine (courtesy of M. Tork, U.S. National Marine Fisheries Service).

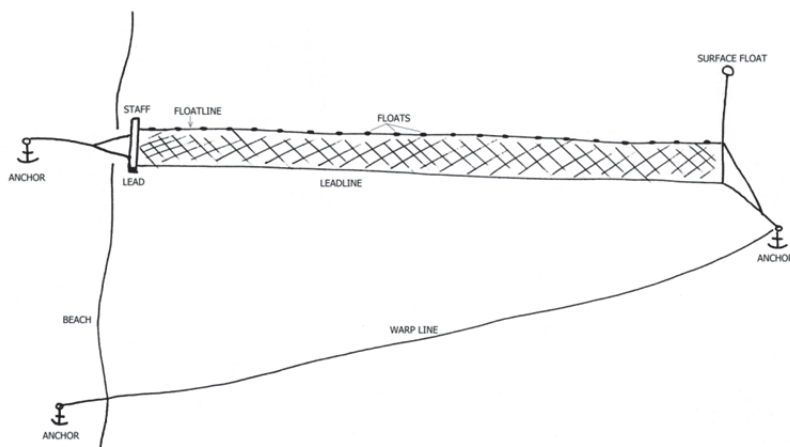

Figure 4. Beach anchored gillnet (courtesy of M. Tork, U.S. National Marine Fisheries Service).

Safety concerns

Limited deck space on gillnet vessels may present issues with observer operations, with regards to sampling, observing the gear, and safety. Fishermen make a quick operation of setting gillnet gear. You should be aware that the operator has limited ability to stop the gear going overboard. You should not be near the gear during deployment.

Gear is brought on deck quickly, resulting in the crew's need to work quickly and efficiently. The small space and fast pace present safety hazards. You need to be cautious, so as not to get clothing or limbs caught within winches or gear. Once onboard, nets are usually flaked into an area on the deck (if not set out immediately). The nets will move around on deck, if not in a set checker location. Special attention to slip hazards must be given.

- Rail Hauler/starboard hauler: Employs a roller and a hydraulic wheel mounted close to the rail. This spins and contains a series of hammers with gripping teeth that open and close on gillnet lines for hauling. These are more commonly seen in the Northeast region.
- Net Drum: Used for hauling gear from the stern of the vessel, similarly to net drums on trawl vessels. These are more commonly seen in the Mid-Atlantic region.

Fishermen work by habit, discarding unwanted catch quickly. As soon as catch is picked from the gear, it's quickly thrown overboard. Effective communication of observer duties with the crew is essential for both proper sampling and not getting hit accidentally with fish.

Due to the nature of gillnet vessels, appropriate sampling stations are limited and commonly cramped. You should attempt to find a sampling station that minimally interferes with fishing operations. However, a common location where you will find space for sampling will be in the direct path of discarded fish. The importance of effective communication with the crew cannot be stressed enough, to try and ensure that there are no accidental injuries. Occasionally, it may be necessary to look over the side of the vessel to monitor an incidental take or pelagic species coming onboard. You should be aware of vessels with low rails, and be careful not to lean your body over the gunnel. Also be aware of large engine exhaust pipes in the middle of the deck. Set up your sampling station away from these areas.

Gear information

The gillnet fishery uses mesh nets which retains fish by becoming enmeshed, entangled or gilled in one or more of the meshes. The term "gilling" refers to the way the fish gill covers or operculae act as barbs to prevent them from escaping. The effectiveness of this equipment is primarily due to its size selectivity, which is based on the net's mesh size. The fish can be either too small or too large to be retained by the mesh. As the fish swim through the net their heads can enter, but they cannot pass beyond the dorsal fin and the largest circumference of their body and become wedged. When the fish try to free themselves by twisting they become entangled, the twine of the mesh hooks behind the operculae and the gills, making it virtually impossible for the fish to move forward or backward.

The majority of gillnets observed by FSB are separated into four major gear types: anchored sink, anchored float, drift sink, or drift float gillnets. Gillnet gear operates as a passive fishing gear made of nylon

monofilament meshes, stretched between a weighted leadline on the bottom and a floatline on the top frame. Positive buoyancy of the floatline counteracts the weighted leadline creating a vertical barrier of netting within the water column.

Gillnets can be suspended at the surface, in mid-water, or on the bottom with specialized gear. Indicators of the use of specialized gears are: the number of droplines, the size and number of floats on the floatline, and the weight of the leadline and anchors.



The gear is typically configured as a series of nets (“string”) tied together by the bridles which may or may not have spaces between each net. Typically, there is a surface system at each end to mark the location and ownership of the gillnet gear to the vessel (see Figure 5). The surface system refers to the configuration of high flyers and/or buoys at the surface of the water. The high flyer is a gear vessel identifier and a locator tool. The metal on the radar reflector is captured on the vessel’s radar screen. The surface system attaches to the gillnet gear with a line called a buoyline. The end of the buoyline connects to either an anchor or directly to the bridles of the net. The surface system attaches to the gillnet gear by a buoyline, which leads to either an anchor or directly to the bridles of the last net (see Figure 1).

If anchors are used on the gear, a number of different objects can be used to hold the gear to the substrate (see Figure 6). Common types of anchors are: the Danforth-style anchor, dead weight anchor, or “other” types of digging anchor. The Atlantic Large Whale Take Reduction Plan has written the Danforth-style anchor into regulations, which is a burying type of anchor. The “other” type includes any other anchor style designed to dig or bury to hold into the substrate. Examples of this “other” type of anchor type include kedge and grapnel. The dead weight style anchor sits on the sea floor surface and uses “dead weight” to weigh down the net. Examples of this anchor type include mushroom style anchors, sections of railroad track, battleship chain, and round cement/metal cylinders.





 Danforth	DANFORTH - STYLE
 Railroad Track	
 Mushroom	DEAD WEIGHT
 Kedge	
 Grapnel	OTHER

Figure 6. Common anchor types.

Gillnets are sometimes configured with Marine Mammal Deterrent Devices (MMDD). MMDDs are devices that allow marine mammals to detect gillnet gear and avoid entanglement. The two types of MMDDs are Active and Passive Marine Mammal Deterrent Devices. An Active MMDD (e.g., pinger) is a device which emits a sound that is detectable by marine mammals, specifically harbor porpoise, to warn the animal of the nearby invisible gear. They are commonly found between each net and on the ends of the gear. A Passive MMDD provides a reflection of marine mammal echolocation signals (e.g., reflective mesh).

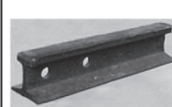
Gillnets are sometimes equipped with breakable components of the gear that will part when subjected to certain tension load, called weak links. The Large Whale Take Reduction Team plan mandates the use of weak

links on gillnet gear on both the surface system and on the gillnet string, depending on area, time of year, and gear type.

Setting a gillnet string begins as the vessel moves slowly forward through the water and the first buoy and/or high flyer is released over the stern, or side, of the vessel. The surface system and the buoyline are released overboard, and may be followed by an anchor and groundline, and finally the string of nets. Nearing the end of deployment of the gear, the end anchor, buoyline, and surface system are released overboard. The surface system is released only after a “stretch” is exerted on the entire string of nets, making it taut.

Gillnets are then left in the water to “soak” from anywhere between a few minutes to several days or weeks, before the vessel returns to “haul in” the gear. Gillnet strings are hauled with the aid of a hydraulic system, or entirely by hand. As the net comes onboard, the fish are removed from the net by the crew. The net is then wound up back onto a net drum or pulled up by a side hauler, then fed into net boxes or simply piled (“flaked”) onto the deck of the vessel. Once the entire string is onboard, the captain may reset the string in the same place, move to a different location to set, or not reset at all and leave the string onboard.

Beach Seines and Beach Anchored Gillnets

Beach-based fisheries are similar to standard gillnets in that they use a wall of webbing to catch fish, but the process of setting and hauling differs, as do some of the gear characteristics.

Beach seines and beach anchored gillnets are set perpendicular to the beach using a dory. At one end, a staff is anchored on the beach, and the other end is anchored offshore with an attached warp that leads back and is anchored to the beach. These nets can at times cover the entire water column.

A beach seine net will include a bunt section at the beach end. At times, a beach seine net may also include a wash net at the beach end. The seine is used primarily to encircle fish and corral them into a concentrated area.

A beach anchored gillnet will **not** include a bunt or wash net section but rather be comprised solely of monofilament gillnet. The gillnet traps individual fish within its meshes.

Observing a Haul

Catch Processing

Typically, catch is brought onboard one fish at a time. The crew may be in the habit of discarding fish as they are picked out of the net; this requires communication before the first haul, as you will need to sample the discarded catch.

There are two types of sampling programs for gillnet fisheries: limited fish sampling and complete fish sampling. The type of trip is determined before the trip begins and should be communicated to you by your provider.

Limited fish sampling

The main focus is to observe and record the interactions of marine protected species (marine mammal, sea turtle, and sea bird) with the gillnet gear. Set up a sampling station at a position located aft of the hauler, with a clear and unobstructed 180 degree view of the gear and surrounding area. During a protected species watch, maintain a continuous watch until the gear is completely onboard. (picture)

Remain at the same location during the entire watch, facing the gear, looking down along the line of the net as it exits the water and is brought up to the vessel. The primary focus should be along that line and where the net breaks the water's surface. Continuous scanning of the water surface, in the designated area to either side of the net, should be done with the naked eye.

Protected species watches are performed on **every haul** of limited fish sampling gillnet trips and all alternative platform sampling trips, regardless of weather conditions. Discarded catch is not recorded or sampled, except for animals that are recorded on the Individual Animal Log and Incidental Take Log. Kept catch weights will be recorded after each haul. Biological sampling of the kept catch should occur only for the last haul of the trip (day trips) after all gear has been brought onboard, or the last haul of each day (multi-day trips).

Complete fish sampling

Choose a sampling station that allows for a view of the catch as it is brought onboard, access to the discarded species, an area for your length board to rest on, access to your personal bucket or basket for weighing purposes, and the ability to throw discards overboard once sampling has been performed. It is imperative to sample catch while maintaining awareness of others. In many situations the crew may continue to throw bycatch species overboard if

deck space is limited and the observer appears occupied.

Every haul should be observed, i.e., complete catch information for both kept and discarded species is recorded. No protected species watches are conducted. The kept and discarded catch of all hauls should be biologically sampled, with priority given to discarded species.

Beach Seine and Beach Anchored Gillnet

The gear is typically left to soak for one tide cycle, or approximately 12 hours, and is hauled in during low tide. The gear is usually hauled up onto the beach by a 4-wheel drive vehicle pulling the offshore warp. As the warp is hauled, the fish are corralled into an ever shrinking inverted "U" shape. The majority of the catch is gilled in the wing or gillnet portion of the gear. For the beach seine, a large catch will be concentrated in the smaller mesh bunt section and simply dumped into totes on the beach. You should be able to obtain actual weights on

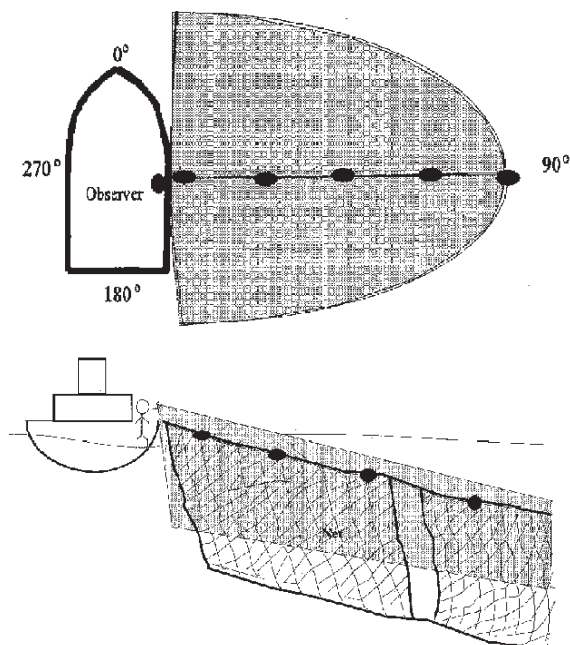

Figure 7. Sighting area for protected species watches. Top: aerial view. Bottom: side view

all kept and discarded fish caught in the net. You should also conduct a protected species watch during these hauls.

Occasionally, these gears are “fished-over” using the dory, instead of being hauled up onto the beach. In this method, the dory picks up one end of the net and leads it across the beam of the dory. The fishermen pick the fish out of the net and set it directly back into the water, without bringing the entire net onboard. If this is the case, you may only be able to weigh the kept catch. You should observe the net for any interactions of protected species, but you will not be able to fulfill the complete requirements for a protected species watch.

Alternative Platform Sampling

The Alternative Platform Program utilizes an independent vessel to observe small commercial fishing vessels in coastal gillnet fisheries that cannot accommodate an observer, to augment conventional observer coverage, or when observers are unavailable. When observing fishing activities from the alternative platform, you will record as much information as possible related to the vessel you are watching. Some information will not be available, e.g., if the fishing vessel had already begun fishing before your vessel arrived.

Sampling Strategies

Small volume discarded bycatch in haul: Completely sample all discards by collecting actual weights, lengths, and biological samples (program-dependent). Proceed to sample the kept catch throughout the haul as time permits.

Discarded bycatch of various species: Focus on the discarded species. Attempt to obtain actual weights for all discards, as well as biological sampling. Once the haul has ended, make an effort to sample the kept catch.

Large volume of uniform discarded bycatch: It would not be possible to obtain actual weights for all individuals, therefore employ the tally method to obtain an approximate total weight. This requires communication with the crew, such as asking them to give you 10-20 animals from the beginning, middle, and end of each haul. It is important to watch for other discards; they must be accounted for even if tossed over immediately.

Large number of IAL species on a limited sampling trip: Record these animals, without interference with the protected species watch. It may be necessary to stroke tally these animals and estimate lengths and weights.

Notes

Longline Fishery

Definitions

Types of Line Gear

Longline: A mainline (“string”) with spaced gangion lines attached which have baited hooks on the free end

Demersal longline: A string that fishes at, or near, the ocean bottom, uniquely configured to target specific demersal species. Generally, gear is a single mainline with pre-baited hooked gangions.

Pelagic longline: A string composed of several sections, and supported within the water column by various sized floats, uniquely configured to target specific pelagic, migratory species. Generally, gear will be several sections of steel cable with snap-on gangions. Dependent on targeted species, light sticks and other specialized gear will be used.

Handline: A weight, leader, and at least one hook that may be baited; attached to a line.

Jig: A type of fishing lure designed to resemble prey species. Typically consists of a heavy, barbed head with a ring attached to the line.

Auto Jig: An electronic mechanism that creates a vertical bobbing motion in the water column (jigging), to one or more artificial lures attached to a line. Auto jig gear should be distinguished from other electronic reels that do not impart a regular up and down jigging motion to the line.

Electronic Reels: Motorized cranking devices that, when started, will reel in line. Typically the unit will be plugged into a power supply on the rail.

Troll Line: One or more lines with hooks and bait, or lures, attached that are towed behind a moving vessel.

Parts of the Gear

Hooks: A piece of metal or other material that can be curved or bent at an angle to target specific types of fish (see Figure 8). There is no world or industry standard method of measuring hooks, but here in the United States, the measures go from the smallest size 32 and count down. As the number decreases, the size increases all the way down to a number 1 hook. At this point, the number changes to a designation of “aughts” or zeroes. A 1/0 hook is the next larger size to a number 1. A 2/0 is larger still, and this numbering scheme goes as high as 19/0.

J-Hook or O’SHAUGHNESSY: This hook is named for the specific design of the hook. It is a standard hook, forged with a very strong bend. This hook is relatively thick, very strong, and not likely to bend out of shape. Generally designed for saltwater, it is good for general bottom fishing use. Hook sizes range from #3 to as large as 19/0.

Circle Hook: Circle hooks promote healthy catch and release. The design of the hook itself, when used properly, prevents fish from being hooked in the gut. These hooks are designed to move to the corner of the fish’s mouth, and set themselves as the fish swims away.

Semi-Circle or Partial Circle Hook: The curve on these hooks makes them ideal for live bait. These hooks will bend if hung on the bottom of some structure. However, once a fish is hooked, the design of the hook prevents it from being straightened.

Weight: Small piece of heavy material (usually lead) that increases the rate at which the hook sinks within water.

Mainline: Primary line on the reel (rod & reel gears) or the string (longline gears). Attachments to it could include gangions, swivels and/ or hooks.

Groundline: A line that connects the anchors to the mainline.

Test: Dry breaking strength of a line.

Section: Each portion of the entire longline string, beginning with a high flyer, radio beacon, or beeper buoy, and ending with the next high flyer, radio beacon, or beeper buoy. Most demersal longline strings are composed of a single section, regardless of the number of tubs.

Gangion: A line and hook attached to the mainline. Gangions may vary in length and have up to 2 swivels, one below an AK snap (if present), and possibly another above the hook. May be referred to as “leaders.”

Leader: A relatively short section of monofilament nylon or steel wire placed between a swivel and the hook. It reduces bite-offs, makes the hook replacement easier, and helps maintain gangion length.

Swivel: A coupling mechanism between parts of gear that allows for free movement between them. Normally placed between mainline and gangion and/or gangion and hook to reduce tangling of gangions. Can be made from plastic or metal, and is made up of two rings connected to a pivoting mechanism.

Snap: A clip at the end of a gangion that makes it easier to remove from the mainline to allow for better storing of gear, unhooking of catch, and rebaiting of hooks.

Surface Gear

Buoyline: A line that connects the surface system to the gear at the anchor or mainline.

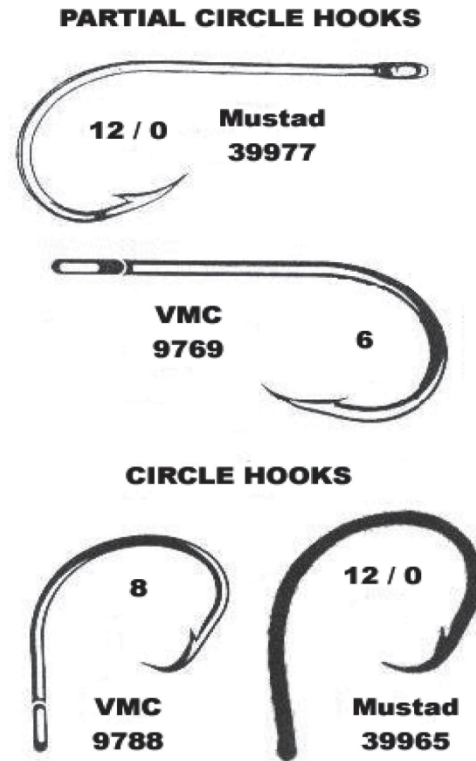

Figure 8. Common hook types.

Surface system: The configuration of high flyers and buoys and/or floats at the surface of the water.

Weak link: A breakable component of gear that will part when subjected to a certain tension load.

Dropline: A line that connects the floats on the water's surface to the mainline, referred to as a "floatline."

Radio beacons: Referred to as "radio buoys" or "beepers". Use radio signals and/or GPS to allow the fishing vessel to locate the gear. More sophisticated models of radio beacon buoys will only transmit when they receive a signal from the vessel, and the most recent versions will obtain a position from a global positioning satellite (GPS) system, and transmit location coordinates to a computerized plotter.

High flyer: Gear vessel identifier and locator tool. If the high flyer has radar reflective components, it can also be considered a radar reflector.

Radar reflectors: Marks location and ownership; visible to vessel's radar screen. Can also be considered a high flyer.

Hauling Terms

Crucifier: A mechanical hook removal component made up of two vertical steel rods.

Tending: When the vessel runs the line and only pulls hooks where floats are submerged; called "hotlining."

Rebaiting: Hooks are hauled, new bait is placed on hooks, and hooks are reset during a haul.

Safety concerns

The hauling station is typically separate from the back deck. Significant safety issues with observing this fishery includes limited and cramped deck space, limited ability to communicate due to fast pace of fishery, and many hooks along the gear.

Gear Information

In New England, longline vessels use gear colloquially known as "tub trawls" to target cod, haddock, hake, and pollock, as well as rays, and many flatfish, such as halibut. In the Mid-Atlantic, longline vessels target tilefish using a distinctly different longline configuration, setting from a reel of steel cable rather than out of totes.

Tub Trawls

Longline gear consists of three basic components: the mainline, the branch line, and the baited hook (see Figure 9). All of these parts are adaptable for targeting specific species through changes in materials, lengths, and deployment strategies. Baited hooks are attached to the free end of gangions which are secured to the mainline. A section of mainline may stand alone or connected to other sections, each distinguished by a high flyer/radar reflector, radio beacon, or beeper buoy on the end.

History of Longlining

The French introduced the longline fishery in the Northwest Atlantic Ocean Grand Banks cod fisheries in about 1789. Although it wasn't until the early 1840's that it came into attention of the local fishermen of Massachusetts who independently developed longlining for halibut. Over the next few years longline gear was adopted by many New Englanders for both cod and halibut.

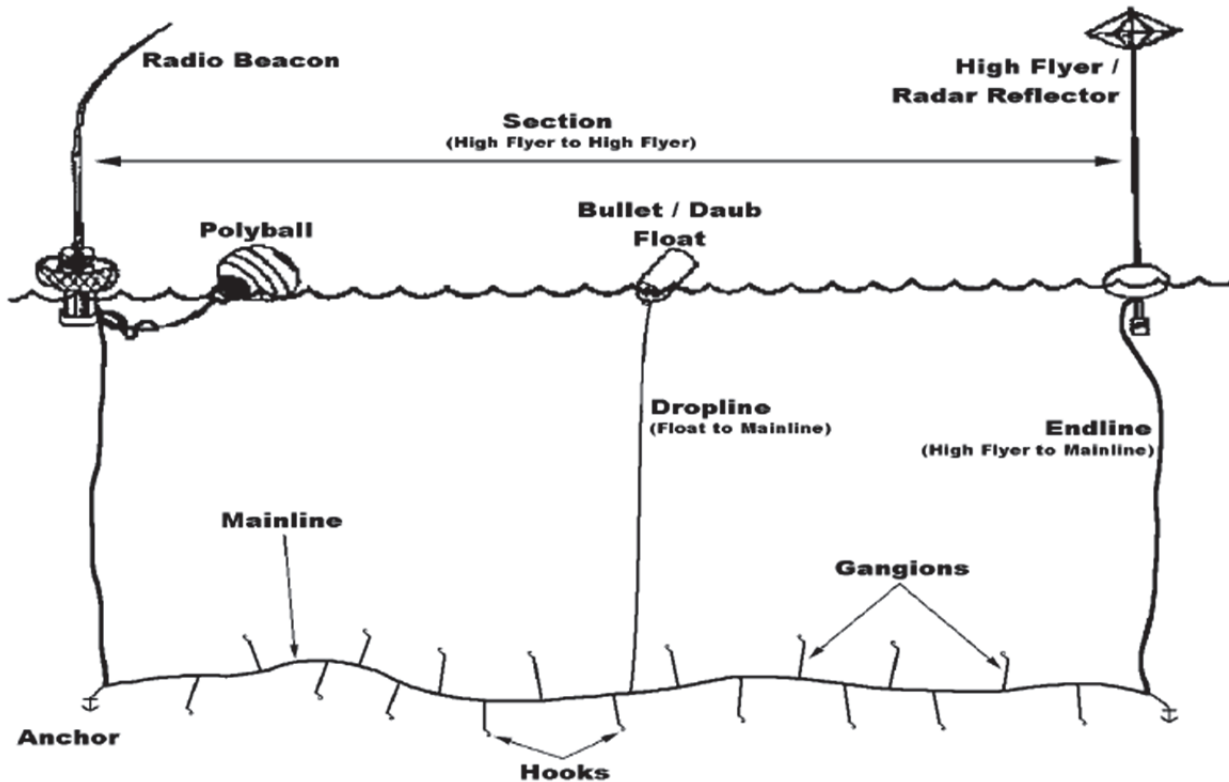

Figure 9. Characteristics of a demersal longline gear.

Setting of longline gear is generally a fast operation. A combination of high flyer and buoy are set on one end, followed by a line attached to the end of the mainline, generally with an anchor affixed. The mainline and baited hooks are then set out over the stern of the vessel into the water. Nearing the end of the line, and once the tension on the line is deemed appropriate, another anchor, buoyline, and surface system is placed into the water. This tension signifies that the anchors have dug into the bottom sediment, and the gear is set in place. Caution should be taken near the deployment of gear. With the rapid deployment of hooks, it is important to be off deck and out of the way of any lines while the gear is being set.

For tub trawl longline, although the mainline is set on the bottom, the gangions may use floats or frozen bait to allow the hooks to hang above the sea floor, protecting the bait against unwanted predators such as seastars, snails, or crabs. The gear is typically stored in totes, consisting of a segment of heavy mainline,

approximately 300 feet long, with gangion lines 1 to 3 feet in length tied on at intervals of about 6 feet. The totes or “tubs” are usually brought to shore for baiting between trips. Captains will sometimes set just one tub of line, but more commonly will tie several lines together to create one gear.

Longline Tilefish

Longline vessels targeting tilefish typically set between 10-25 nm of gear per day, and fish between 4000 and 4500 hooks per day. Gear is fished in about 60-80 fathoms depth of water. Gangions are snapped on by hand, and are made with either stainless steel or monofilament, depending on the length of the longline and the vessel horsepower in hauling; if hauled too fast the line will part. The hooks are typically baited with shortfin squid or frozen mackerel. Commonly, these longlines are not pre-baited, since trips are multi-day trips and fishermen will fish the string more than once per trip. Crew most likely will rebait lines during the trip; either all hooks at once or only pull lines partially and then rebait those particular hooks.

There is a large drum of wire cable on the back deck. A high flyer, typically with an accompanying buoy, is attached to the end and based on the water depth; a significant length of wire is let out over the stern of the vessel, acting as buoyline. After the desired length is set, an anchor is attached and the crew begins snapping on pieces of monofilament line with baited hooks at varying increments.

The captain sets the line either in a straight line, or in a zigzag like pattern. Once he has let out the desired length of mainline (e.g., number of hooks set out), an anchor is attached and another shot of line is let out, before attaching a surface system to the other end.

Handline

Handlines and jigs are generally configured with a weight, leader, and at least one hook attached to a line. These gears may use baited hooks or fish-shaped lures made of plastic or metal with a barb at the end, which vary according to target species. Handline gears generally target demersal species like Atlantic cod, pollock, haddock, and spiny dogfish but may also fish for pelagic species such as tuna, bluefish, and striped bass.

Although the gear is popular with recreational fishing, commercial handline vessels are usually smaller than other fisheries' vessels, averaging 30-50 feet in length. Trips on these vessels are usually single day trips, but some may stay out overnight, with a crew consisting of a captain and single deckhand. Handline, auto jig, or trolling may be either the primary gear on trips, or used to supplement catch on gillnet or longline trips. These gears can also be used to “test the waters” in the area the captain intends to fish before setting the main gear he has onboard, resulting in a multi-gear trip.

Handline gears all start with a long section of line on a spooled reel, but there are a couple of different configurations that are commonly used. The first is a simple configuration in which a weight is attached to a swivel towards the end of the line, then a short piece of line with a hook or jig attached. The second has one or multiple three-way swivels that are attached towards the end of the mainline. There are short pieces of line connected to the two free rings of the swivel; one with a weight at the end, the other with a hook or jig.

Handlines are not always held when fished; some are put into holders on the side rails and stern of the vessel. Handlines typically use a spooled reel to crank or wind catch from the water once hooked. There are some electronic reels that plug into an electrical source, which save the fishermen time and energy by reducing the

cranking motion, and will automatically reel the line in when they register tension on the lines. A single vessel may place one or more rod and reels on the side rails or stern, depending target species.

An auto jig is an electronic, computerized mechanism that creates a vertical bobbing motion in the water column (imitates jigging), not to be confused with an electronic reel. There may be one or more auto jigs used on the sides or stern of the vessel, and captain and/or crew will typically set the computer for depth of fishing and jig travel distance. Once a fish is hooked, the line will automatically be reeled in.

Troll fishing commonly uses one or more lines with live bait or artificial lure baited hooks or jigs. These are towed at 1-9 knots behind a moving vessel, depending on target species. There may be a kite at the very end of the mainline, which will use air resistance to make the hook(s) graze the water's surface to target species like tuna or bluefish. If the vessel is night fishing, the crew may attach light sticks to the gear. Troll lines typically have multiple hook sections attached to a mainline. The mainline may run to handlines, auto jigs, or outriggers on the vessel.

Observing a Haul

Catch Processing

Tub Trawl Longline Fishery

Hauling gear is quick, yet how fast will depend on the size of the catch. Once the surface system and anchor are retrieved, the line is brought onboard using a hydraulic hauler fed through metal rollers or "crucifiers." The hauling station is commonly a small, finite space, only allowing for 1 or 2 working crew members, and is usually separated from the back deck by a board or door. An ideal sampling location will be on the same side of the vessel as the hauler, just behind the board or door, near a work table. Hooks are brought onboard one at a time, so it is possible to sample all catch depending on the speed of the crew.

Longline Tilefish Fishery

The highflyer and/or buoy are hooked by a gaff and brought onboard. The line is fed through the hauler and over the drum, and begins to be wound up. When the anchor is retrieved, it is detached from the cable and stored for later use, and the hooks begin coming over the rail one at a time. The captain typically stands at the hauler, unhooking gangions as they come in, tossing it and any attached catch onto a work table. At the table, one crew member unhooks fish and rebaits hooks, while another crew member preps bait and dresses kept catch. The

History of the tilefish fishery

Currently, longline vessels account for more than 80% of the commercial catch of tilefish. Since the early 1900s, tilefish have been harvested off the Mid-Atlantic and New England coasts using longline gear, and to a lesser extent, otter trawls.

After World War II, a trawl fishery developed in New England and accounted for most of the landings through the mid-1960s. In the early 1970s, a directed commercial longline fishery rapidly developed and expanded in the Mid-Atlantic region. In the early 1980s, several New Jersey-based vessels switched to other fisheries such as swordfish. By the late 1980s and early 1990s, participants in the tilefish fishery were primarily from eastern Long Island, NY and had upgraded their vessels and adapted to newer technologies. These larger steel-hulled vessels were more resilient to bad weather and able to steam further offshore. Trip length increased and the fleet became more dedicated to tilefish fishing. Nearly all the tilefish landed in the Northeast region are gutted, iced, and trucked to New York City's Fulton Fish Market for redistribution and sale.

kept fish is then thrown into a water tank to be washed before it is placed in the fish hold. Typically, a third crew member is either present to help with the catch or in the cabin catching up on sleep.

Choose a sampling station at the rail on the same side of the vessel as the hauler. This will allow for full view of gear as it is coming out of the water so the observer can view and account for any larger species that cannot be brought onboard. Ideally, this station will also be close to the workbench where fish are being removed from hooks, and forward of the area fish are placed to keep.

Handline Fishery

Hauling gear is fast paced, depending on the size of the catch. Crew will be running along the sides, stern, and possibly around hydraulics of outriggers (trolling). Once a fish is hooked, it will typically be brought up immediately, and taken off the line. The hook will then be re-baited and set back into the water. Given time, the kept catch may be gutted immediately, then thrown into holding pens and iced. Discards are usually picked off the hook, and thrown overboard immediately.

A haul in the handline fishery is defined as a section of time that the gear is fished without a break, regardless of the number of times the line was reeled in. New hauls will begin when there is a break in fishing activity or the vessel has hauled in all gear and steamed to a different location.

Scenarios

Vessel sets gear, hauls part of it, resets that section or partial section, then hauls whole gear. This is one haul, one gear, with rebaited hooks. The number of hooks set and mainline length reflect the gear that is originally set in the water. The number of hooks rebaited will be the number added after the partial haul. The number of hooks hauled will be the number of hooks set plus the number of hooks rebaited, minus any hooks lost.

Vessel sets gear, hauls a portion of it, attaches highflyer to original string, sets hauled portion in new location, returns to original gear to haul and then hauls section that was separated. This would constitute 3 hauls, 2 gears. The first haul used the first gear, whole string, which will end when the piece of gear is sectioned off. The second haul begins when the vessel returns to the first gear to continue hauling, the number of hooks set and mainline length remain the same as the first haul, reflecting the original gear set, but the number of hooks hauled will reflect that the gear was shortened. The third haul will use the second gear, which is the small portion of the first gear that was cut off.

When in doubt, record each time gear is set and hauled separately, with many notes about the length of gear and number of hooks hauled. It is easier to combine hauls than to split them up.

Sampling Strategies

An ideal sampling station would be out of the way of the lines and crew, perhaps just outside the wheelhouse, in a corner deck area. If lines are placed on one side of the vessel, the opposite side of the rail would make for an ideal sampling station. Good communication between you and the captain/crew is imperative, in order to quantify catch.

Because the catch is brought in one hook at a time, it is manageable for the observer to weigh and biologically sample all species that come onboard. Communication with the captain and crew is essential so fish are not thrown overboard before sampling occurs. The crew's priority is unhooking, gutting and storing the kept catch, so prioritize completely sampling discarded catch while obtaining a tally count, basket count, or captain's estimate on kept catch.

If there are a lot of discards, the captain may just let them pop off the hook at the crucifier rather than bringing them onboard. In this situation, it is best to utilize tally method to quantify those discards, while other weights are obtained by actually weighing catch. You should request a number of discards for each species to obtain an average weight for a tally count; preferably these animals will be sampled throughout the haul to account for any size variation.

For hauls with large quantities of kept catch, it might be best to utilize tally method or captain's estimates on those species while directing attention to collecting actual weights on all discarded catch.

Catch that is too large to be brought onboard (e.g., sharks) is typically released by using a gaff with a knife affixed to the end to cut the monofilament line of the gangion. The hook generally remains in the mouth of the individual, but they usually swim away alive. The weight for these animals will have to be visually estimated.

Handline

Catch must be recorded separately for each rod and reel. This requires communication with the crew, who will probably be used to mixing kept catch from all lines. A common sampling set up on deck involves placing two containers (one for kept and one for discards) behind each gear, so the crew can easily throw catch into them.

Waterproof notebook organization is critical when recording data. It may be helpful to section off your notebook, according to how many handline/auto jig/troll line gear(s) there are. This may help you keep track of what catch came from what gear and haul.

Notes

Pot and Trap Fisheries

Definitions

Lobster, Crab, or Fish Pot Trawl: A series of traps attached to a groundline (“the trawl or string”, see Figure 10). Each trap contains a ballast, to ensure minimal movement on the ocean floor. The traps are generally baited and configured to allow entry, but not exit, of the desired size of the targeted species. Traps are configured to allow entry of target species and exit of undersized target species and non-desired species.

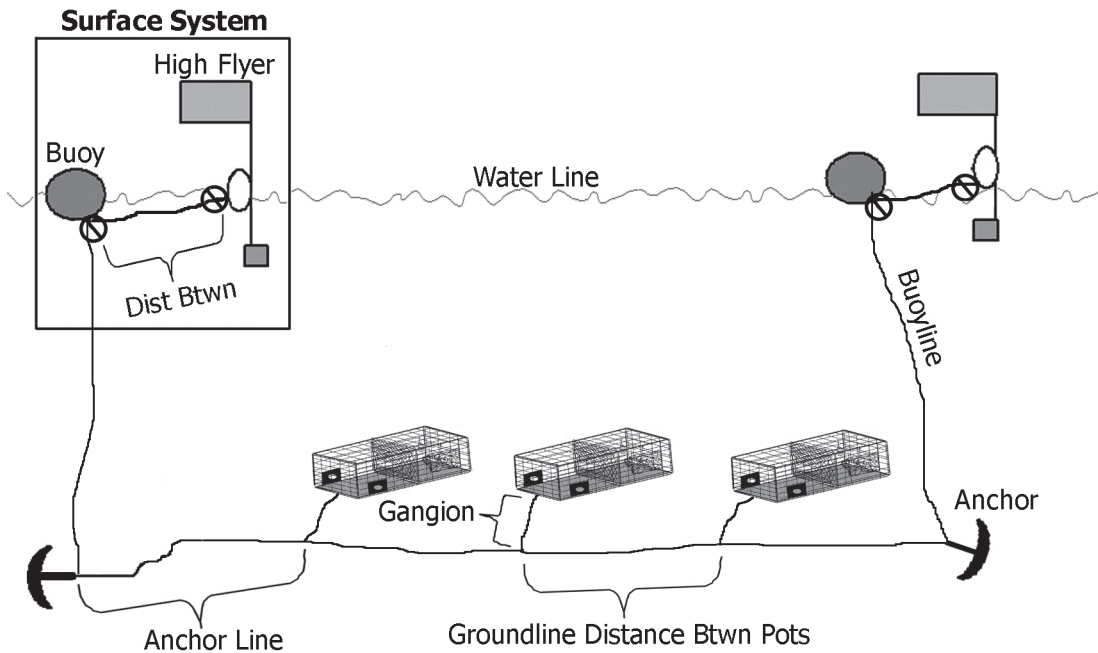

Figure 10. Typical pot/trap trawl gear configuration.

Kitchen: Section of the trap where the bait is located.

Parlor: Section of the trap from which animals are removed by the fisherman.

Collar: A non-return device in the shape of a funnel whose tapered end is directed away from the opening and into the catch/bait chamber. This device is common in crab, eel, and fish pots and is also called “the throat.”

Gear: An individual lobster, crab, or fish pot trawl (may also be used to describe a group of trawls that have been aggregated, see Observing a Haul).

Surface System: The configuration of high flyers and buoys/floats at the surface of the water.

Buoyline: A line that connects the surface system to the gear (anchor or pot/trap) fishing in the water below. A line that connects the gear to the vessel is not considered a buoyline.

Groundline: A line that connects the pot/traps to form a pot/trap trawl or string.

Gangion: A line that attaches a pot/trap to the groundline.

Anchor Line: A line that connects the anchor to the closest (first or last) gangion.

Weak link: A breakable component of gear that will part when subjected to a certain tension load. Common types of weaklinks are:

- *Rope of appropriate breaking strength*: Will break at a certain tension.
- *Off the shelf*: Commercially available and stamped with the breaking weight.
- *Overhand knot*: A line that is cut and retied back together with an overhand knot.
- *Hog rings*: Steel rings which are clamped down on a line that can be released with a certain amount of tension.

Safety Concerns

Boats in this fishery may be open stern; you should stay away from the stern of these vessels at all times.

When gear is being set, be aware of the location of the lines. Lines are usually coiled before gear is set, but all lines on pot/trap vessels pose a major safety risk. Once entangled, it could take some time to recover a man overboard and disentangle the line. Avoid being near lines at all times, but especially when gear is being deployed. Observers deployed on pot/trap trips should ALWAYS carry a knife.

Crabs and lobsters have strong, sharp pincers and should always be handled carefully. Most animals in a trap will be alive, so be careful to avoid teeth, spines, and claws. Always handle live catch carefully; kept animals may be sold alive, and fishermen will usually want to return live discards to the water as soon as possible to maximize survivability.

On hagfish trips, it is important to be aware of the large amounts of slippery slime produced by the hagfish.

Gear Information

The pot and trap fishery uses pots or traps, designed to catch a target species, by means of a system of entrances (metal ring, mesh outline, or unobstructed opening) and sectioned off portions of the trap. After the target species enters the trap, escape is often still possible by means of the escape vent (where applicable, and when size appropriate) or entrance. Pot/trap gear is able to catch a wide variety of species across a broad range of sizes. Selectivity of this gear is related to the sizes of the trap entrance and escape vent. Individuals that are too large to fit through the entrance are excluded from the gear, and individuals that are larger than the escape vent are retained by the trap. Vents are designed to release undersized target species and bycatch species after they have entered the trap, while retaining legal sized individuals. Animals can sometimes exit the trap through the entrance as well.

FSB observers are trained to cover a number of pot and trap fisheries, including lobster, mixed Jonah crab and lobster, whelk, fish, hagfish, and deep sea red crab. The design of pot and trap gear depends on the target species, resulting in many differences in gear configuration. The characteristics of pot and trap gear used to carry out these fisheries are described below.

Pot Characteristics

Pots and traps used in the fish, lobster, and crab fisheries are generally made of wire mesh, wood slats, or some combination of the two (see Figure 11). Pots and traps in the whelk fishery are made of different materials, depending on the region, including wire mesh, wood slats, plastic barrels, and nylon mesh. Hagfish are caught using large plastic barrels. Traps are often circular (crab, fish, whelk, hagfish) or rectangular (lobster, whelk, crab, fish), but come in other shapes (heart-shaped, conical, etc.) as well.

Pot and trap fisheries management

Pot and trap fisheries are managed by a combination of state, regional, and federal agencies. The Atlantic States Marine Fisheries Commission (ASMFC) manages the inshore lobster stock, in cooperation with state agencies. NOAA manages the offshore stock, and provides input into the ASMFC stock assessment process. The Atlantic Large Whale Take Reduction Plan (ALWTRP) is administered by NOAA, with the intent to reduce injuries and deaths of large whales due to entanglement in fishing gear. The ALWTRP specifies the configuration of pot/trap gear and is updated on a regular basis. The ALWTRP is also used to implement closures, exemptions and new definitions.

RECTANGULAR LOBSTER TRAP WIRE CONSTRUCTION

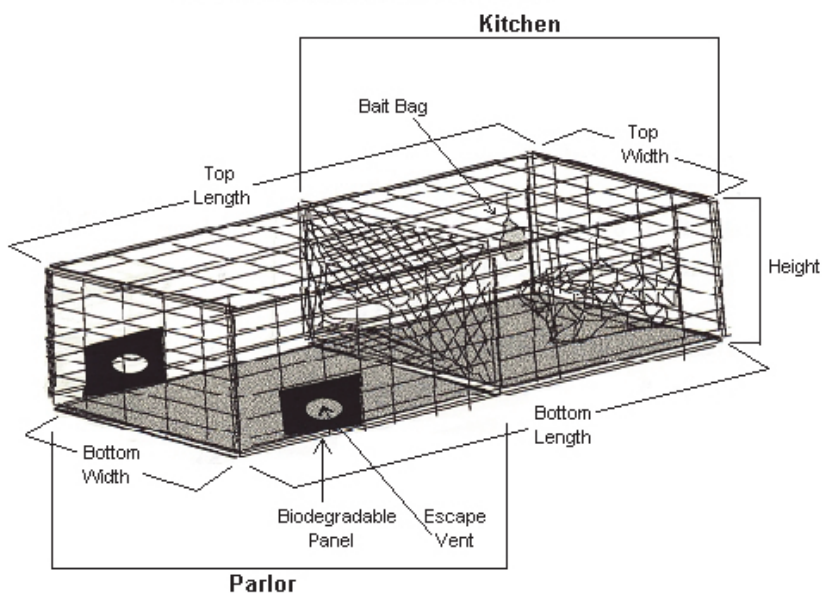

Figure 11. Typical lobster trap configuration.

Trap entrances vary in size, shape, and material. Lobster, crab, and some fish pots have metal or plastic rings located in the mouth of the trap entrance. Entrance rings are usually located on the sides or ends of the trap. Whelk pot entrances are usually not well defined, as traps are not entirely enclosed, remaining open on the top of the trap to permit whelks to enter. Hagfish pot entrances are conical in shape, with the widest portion of the cone located on the exterior of the pot, tapering to a point within the pot.

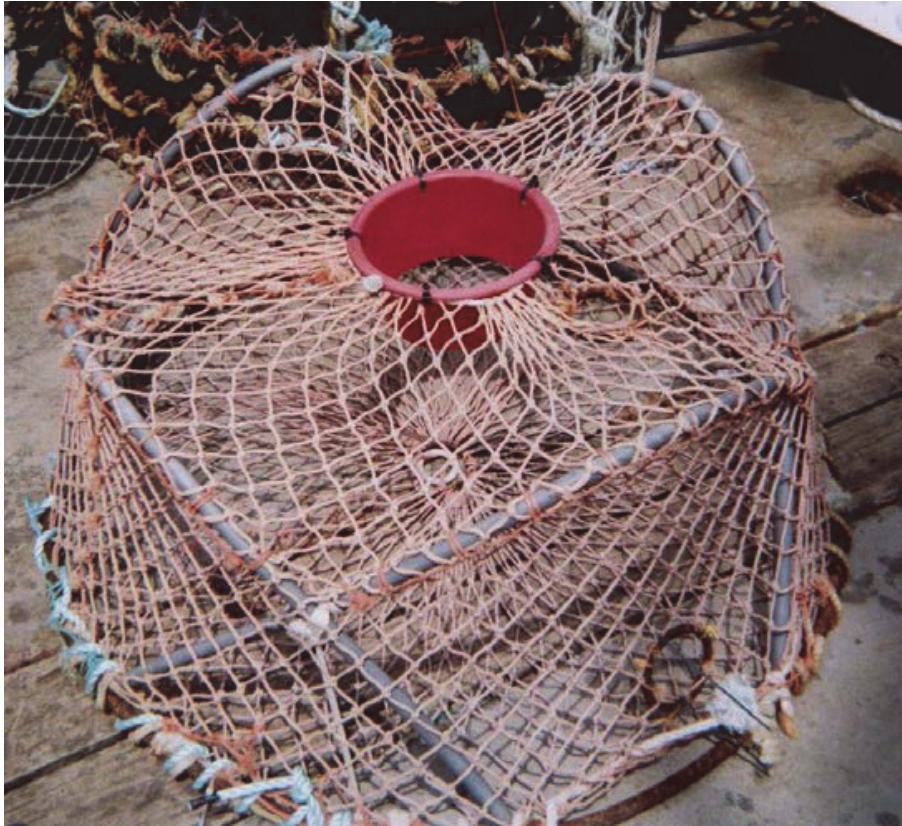

Figure 12. Red crab trap. Note entrance ring (red, top) and escape vent (brown, lower right-hand corner).

Traps used to catch lobster, crabs, fish, and hagfish usually have escape vents integrated within the trap. Escape vents in the fish, lobster, and crab fisheries are often made of hard biodegradable plastic material. These vents may be located on the side or top of the trap, depending on the age of the trap, and preference of the captain. Vents are usually oriented horizontally, but may sometimes be oriented vertically. Vents designed to release undersized lobsters are usually rectangular, while vents designed to release crab and fish are usually circular. Hagfish pot escape vents are small holes drilled into the sides of the plastic barrels. Whelk pots generally do not have escape vents.



Figure 13. Hagfish pots showing escape vents.

Lobster, crab, and fish pot escape vents are usually attached to the trap using a biodegradable material that prevents the trap from continuing to fish if it is lost. Materials used include iron hog rings, biodegradable plastic, wood, or uncoated wire. Many captains will use these materials in order to count the escape vent as their biodegradable panel. Traps must have a biodegradable panel in place to prevent the traps from continuing to fish if lost.

Lobster traps are often modified to fish for Jonah crabs by captains. Zip ties are attached to the escape vents, roughly in the middle of the vent, to prevent larger crabs from escaping. These traps often have circular crab escape vents, in addition to the standard rectangular lobster escape vents. Some traps (usually offshore lobster and crab) have concrete or wooden runners attached to the bottom of the trap for added weight.

Traps are usually baited in pot and trap fisheries, and may use bait bags, metal rings, string, or another method (including a combination) to secure the bait. Most fish pots are not baited. Remember to ask the captain about the bait used to catch the target species.

Trawl Characteristics

Across fisheries, traps may be fished singly or in trawls of traps, ranging from 2-200 per trawl. Single traps are fished using a single buoy or high flyer (sometimes both) attached to a buoyline (see Figure 10). Buoylines are typically made up of a combination of sinking/ neutrally buoyant and floating line, and are usually attached directly to the trap when fishing single traps. Trawls of traps are fished using buoys and/or high flyers. Some captains prefer to use only buoys, others only high flyers. Captains will often use a high flyer and a buoy on one, or both, ends of the trawl. High flyers and buoys are attached to both ends of a trawl on many offshore pot/trap trips and in areas with large tidal ranges or active mobile gear. When a buoy and high flyer are used on the same end of a trawl, the surface line connecting the high flyer and buoy is usually sinking/ neutrally

buoyant. Weak links are used in pot and trap fisheries as part of measures designed to reduce the likelihood of large whale entanglements. Weak links may be integrated with the buoyline and surface line (typically 1 weak link per each buoy and high flyer), but are not required in all fisheries or areas.

Some pot/trap gear includes anchors, other pot/trap gear does not. Anchors are most commonly used offshore, and in areas with strong tides. Some anchors are store bought Danforth-style anchors, others are custom made from dead weight (see Figure 6). Where anchors are used, anchor lines are often made of sinking/ neutrally buoyant materials. Anchor lines run from the anchor to the first trap. Some traps contain bricks, or some other weight, to keep the trap settled on the bottom; these are not considered anchors.

The groundline runs along the bottom, starting at the first trap in the trawl, and running to the last trap in the trawl. The groundline is often made of sinking/ neutrally buoyant materials. Each trap is attached to the groundline by means of a gangion. Gangions are usually sinking/ neutrally buoyant and are attached to the trap using a bridle. Some captains prefer to tie traps directly to the groundline and do not use gangions.

Setting the gear

Traps are set similarly across pot/trap fisheries. The vessel moves through the water, and one end of the surface system (surface line, high flyer, buoy) is deployed over the stern. This is followed by the anchor, anchor line, and groundline. Traps are usually stacked on deck by order of deployment, and are pulled off the stern by the weight of the deployed gear. At the end of the deployment, the other end of the surface system is deployed. Trawls or traps are usually deployed in a straight line; single pots and smaller trawls (1-3 pots) may be deployed in a line, staggered, or grouped.

Traps may be left to soak for anywhere from 1-29 days, depending on the fishery. Each unique set of gear is usually hauled once per trip, except in the offshore lobster fishery, where gear is often hauled twice per trip. Always ask the captain if gear will be hauled twice or more on an offshore pot/trap trip. If gear will be hauled more than once, gear numbers must be tracked throughout the trip. Note gear number, set coordinates, set time, and set date in a waterproof notebook when gear is re-set. When the gear is re-hauled later in the trip, use either the set coordinates or numbered polyball to match up the gear number and transfer the set information to the haul log.

Observing a Haul

See Crustacean Sampling for more details on biological sampling of crustaceans.

Catch Processing

Lobster pot/trap

In the lobster fishery, traps are brought on deck, and catch is sorted at a high rate of speed. Catch volume varies, depending on the time of year and location. The volume of catch, in addition to vessel layout, level of cooperation from the crew, and observer experience, will determine which sampling strategy works best. Communication with crew *before* fishing starts, as well as during fishing activity, is important to facilitate sample collection. Make sure crew members understand your sampling strategy, and which portions of the catch you require access to. Choose a sampling strategy based on how a particular trip (or portion of a trip, if offshore) is going, do not assume that a strategy will work for every trip or haul.

Mixed crab and lobster pot/trap trips

The mixed Jonah crab and lobster fishery is carried out by vessels from Maine to the Mid-Atlantic. The fishery is volume-based, meaning catch volumes must be high to make the fishery economically viable. This is a fast paced fishery, similar to the lobster fishery. Most of the catch, by number of individuals and total weight, consists of crabs. Lobster catch varies, sometimes only a trace amount, other times a large portion of the catch. Communication is key in this fishery to ensure sample collection.

Some captains sort the crab catch into kept and discarded (e.g., undersized, female, egg-bearing) categories, while others keep all crab caught. If crew is keeping all crabs, this simplifies total count and weight estimates. If lobster catches are light and crew is willing, you may ask the crew to either 1) set all the lobster catch aside for you to sample at the end of the haul or 2) verbally provide you with tallies of lobster catch per each trap by fish disposition code.

Whelk pot/trap

Vessels usually target 1 or 2 species of whelk, and the majority of the catch consists of one of the two species. Some vessels fish trawls of 10 or more pots, while others fish 1, 2, or 3 pot trawls. If the vessel is fishing trawls of 10 or more pots, try to observe as many hauls as possible.

If a large number of discarded undersized whelk are caught on a particular haul and time is a limiting factor, subsample the discarded whelk. Use the weight-to-weight ratio method to determine the multiplier (see Count-to-Count and Weight-to-Weight).

Catches are usually light enough to observe most hauls and record catch weights. Sample (weight and length frequency) any finfish catch or other bycatch.

Fish pot/trap

Many fish pot trips target a small amount of high quality catch for the live or high-end markets. Some trips target a mix of species, or operate under larger quotas. Hauling of gear and sorting of catch is fast paced, and vessels in the fish pot fishery are generally small. Biologically sample all finfish with an emphasis on the target species and commercially valuable or ACE species (including wolffish and ocean pout). Catches are usually manageable on fish pot trips, so obtain actual weights or basket count/tallies whenever possible.

Hagfish pot/trap

Hagfish pots are usually full of hagfish when hauled. Barrels come up quickly, and the sorting process is also fast. Obtain catch weights (kept and discarded) using an average weight per barrel, actual weights, basket count, or other acceptable method. Avoid captain's estimates and visual estimates if at all possible. Biologically sample hagfish and any finfish.

Deep sea red crab pot/trap

Traps come up quickly, and catch is sorted into tanks by crew quickly. Subsample discarded catch if necessary, and obtain actual weights where possible. Avoid captain's estimates or visual estimates.

Blue crab pot/trap

Traps come up quickly, and catch is sorted quickly by crew. Obtain actual or tally weights whenever possible, and try to avoid visual estimates or captain's estimates.

Scenarios

Aggregating trawls of traps

In the lobster, Jonah crab, and whelk fisheries, if the captain is fishing trawls of 1, 2, or 3 pots in a small geographic area or in a line, groups or lines of traps may be described as a single gear and haul, with catch combined for all traps. When aggregating smaller trawls of gear, the grouping should reflect the intent of the captain. Some captains set trawls in a line or group small trawls around an area known to contain the target species. Aggregated pot/trap gear should reflect these aggregations, and should not be arbitrarily grouped by you. Consult with the captain before aggregating trawls, to ensure gear and haul logs reflect the intention of the captain when setting gear. Strategies 2 or 3 may be used within grouped trawls if catch volume precludes sampling all catch.

Sampling Strategies

The strategies described below are designed for hauls targeting lobsters and/or Jonah crabs, but may be adapted for use in other pot/trap fisheries as needed. These strategies have been created based on feedback from observers and the fishing industry, to enable data collection from this challenging fishery. Always observe (obtain actual and/or estimated weights of all discarded and kept catch) at least 75% of the hauls during a trip.

Strategy 1 – Biologically sample all observed hauls: This strategy is most appropriate when observing a trip in an area with low catch volume, or at a point during the year where catch volume is relatively low. You will need cooperation from the crew to provide lobster catch, adequate deck space to store and sample the lobster catch, and time to complete sampling.

Strategy 2 – Biologically sample 50% of hauls: This strategy may be used on trawls of gear (or aggregated trawls of gear) when catch volume or deck space does not permit sampling all catch from every haul, but there is sufficient time and space to sample lobsters every other haul. Continue to collect lobster and fish catch weights from hauls where the lobster catch is not sampled.

Strategy 3 – Biologically sample a subsample of traps on each haul: Sample lobster catch from every 5th trap, or a greater percentage if time and space allows. Sample trawls at a consistent percentage once started. This way, sampling is representative of the entire trawl and over or under sampling does not occur. Actual or tallied weights for lobsters are preferred, but if deck space and other factors rule out these options, total weight by disposition can be extrapolated from the 20% of traps that were sampled. This strategy should only be used with trawls of traps (or aggregated smaller trawls) totaling 10 or more traps. This strategy is inappropriate for light catches. Note what percentage is sampled for clarity in data editing and processing.

Notes

Trawl Fisheries

Definitions

Gear: A trawl, commonly referred to as “the net.” This includes ground cables, headrope, footrope, floats, weights, codend/liner, and any attached equipment.

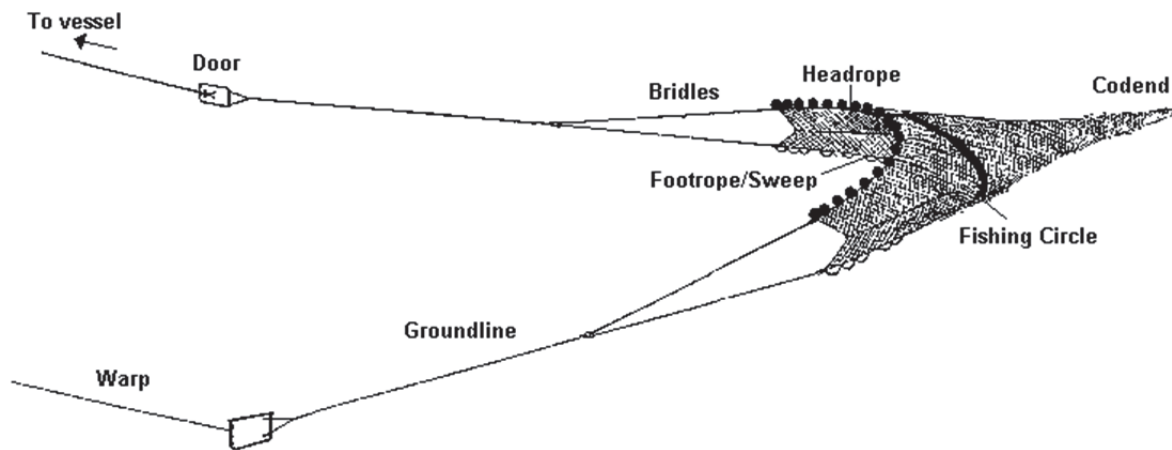

Figure 14. Basic bottom otter trawl configuration.

Square: The section of netting fitted between the top body and the two top wings, so that it partially overhangs the footrope (see Figure 15).

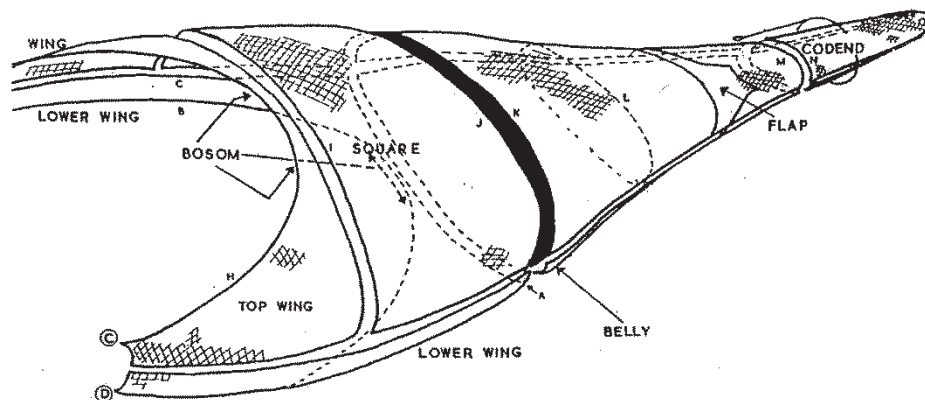

Figure 15. Sections of netting in a trawl gear.

Top Wings: Two sections of netting, usually shaped diagonally opposite one another, that form the upper mouth of the trawl (see Figure 15). The headrope is attached from one top wing end to the other, along the diagonal flymesh edges and across the bosom, or center part, of the square.

Lower Wings: Two narrow sections of netting fitted between the lower belly and the top wings to form the lower lip of the trawl net (see Figure 15). The footrope is attached from one wing end to the other, along the

flymesh edges and across the lower belly bosom meshes. The lower wings are subject to the most abrasion, and consequently they are the sections which have to be continually repaired or replaced when working rough bottom substrate.

Bridle: Connects the wings of the net to the ground cable, which eventually leads to the doors (see Figure 16). In the pair trawl fishery, the bridle is a line coming directly off a net wing, connecting to a warp.

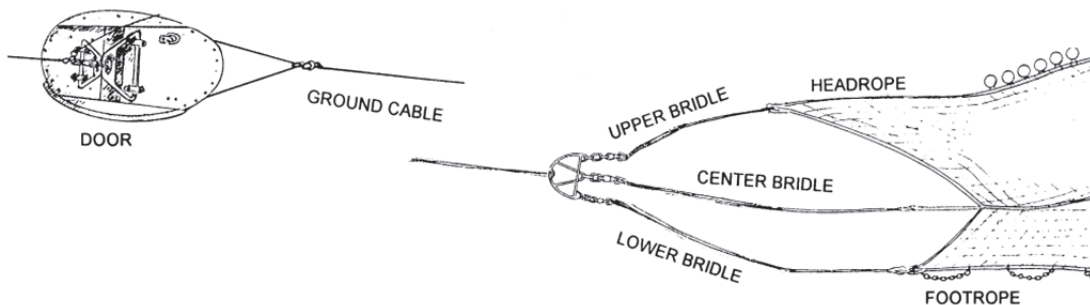

Figure 16. Trawl doors, ground cable, bridles, headrope, and footrope.

Blowout: Generally made with a lighter material than the rest of the net, these net sections are used for maintaining the net's shape and stability as it is pulled through the water (see Figure 17). Commonly seen in the pair trawl fisheries.

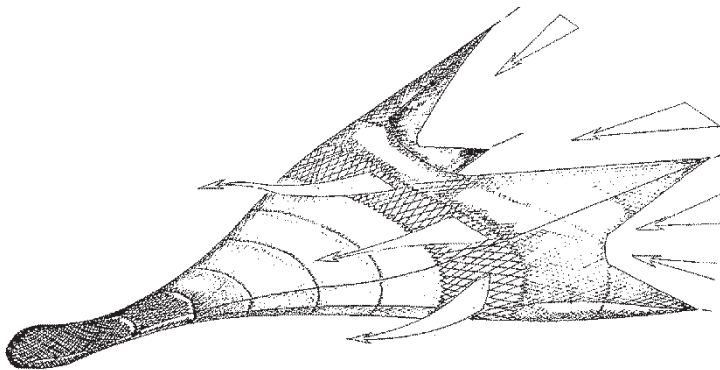

Figure 17. Blowout panels on a midwater trawl net.

Codend: Two rectangular pieces of netting made with heavy twine. The top edges are joined to the narrow end of the bellies, the selvages are laced together, and a codline or codend clip is woven through the lower meshes for securing the section into a bag where the fish are held, until released onboard the vessel. The codend is the section of the trawl net most often affected by mesh size regulations. The size of the codend depends on the species being targeted and regulations.

Codend Liner: A section of small mesh net sewn into the inside of the codend bag, the purpose of which is to restrict the escapement of smaller species, e.g., squid. On midwater trawls, the liner is referred to as a brailer, and may extend halfway up the belly of the net.

Fishing Circle: The section of the net located behind the wings and before the belly. It is the area which creates the largest opening in the net.

Headrope: The line, generally of fiber rope or steel wire rope, which fits along the top wings and center part of the square to form the upper lip of the trawl.

Chafing Gear: Protects the codend from rips and tears. Usually “horse hair,” but sometimes old codends are used.

Codend Strengtheners: Any material attached to the outside of the codend bag or liner to prevent a full net from bursting when it is being lifted onboard. This material may be in the form of strengthening ropes, which are attached lengthwise, and/or circumferentially, to restrict stretching of the codend, or a strengthening/lifting bag, which is a cylinder of netting surrounding the codend. A strengthening bag may also be considered chafing gear.

Transducer: Conveys information regarding the status of fishing activity. May be located on various parts of the fishing gear.

Excluder/Separator Device: A modification to a common bottom trawl that helps prevent the capture of non-target species. It can redirect or allow those species to naturally swim toward an escape outlet once inside trawl. Alternatively, it can inhibit some species from entering the trawl. An excluder/separator device may be present without an escape outlet.

Examples of Excluder/Separator Devices

A horizontal separator panel in the belly of the net separates upward- and downward-swimming species.

A panel of large meshes allows certain species to escape. Large meshes also function as an escape outlet.

A metal grate directs some species towards an escape outlet (see Figure 18).

A raised footrope, or drop chain sweep, excludes fish on the bottom from entering the trawl. Some nets are designed with a longer headrope than footrope to prevent capture of upward-swimming fishes.

Escape Outlet: An intentional opening in the net that allows non-target species to exit the trawl (see Figure 18). Escape outlets must be associated with a separator device; a torn hole in the net does not qualify as an outlet. Escape outlets may be located on various parts of the net (top, bottom, near the front, near the codend, etc.)

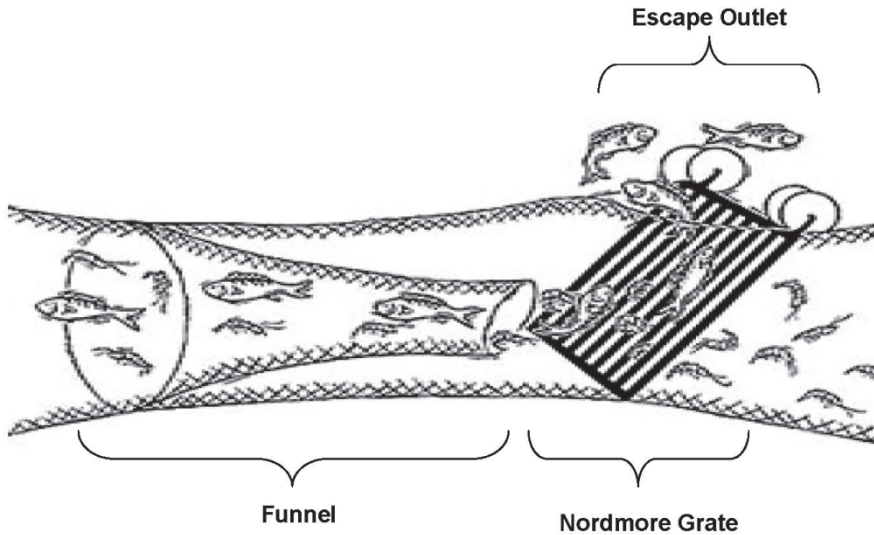

Figure 18. Example of a separator device (Nordmore grate) and escape outlet.

Kites: Canvas panels attached to the headrope to keep the mouth open (see Figure 19). The bag that holds the gear mounted electronics is not considered a kite.

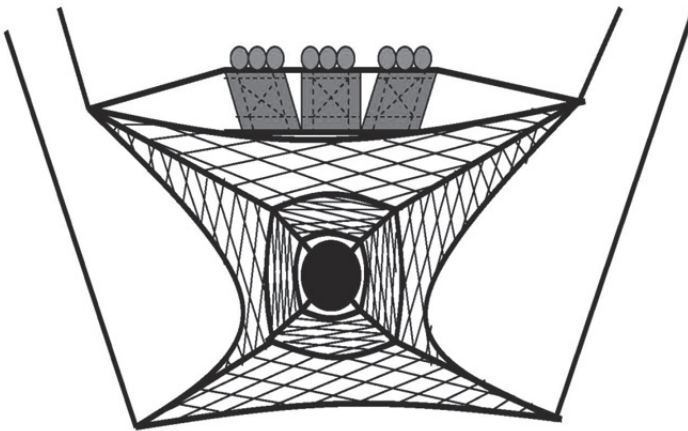

Figure 19. Kite panels on a midwater trawl gear.

Safety concerns

There are several safety hazards to be aware of when observing on a trawler. Usually during catch sorting, the vessel is setting gear back out, or has already set gear back out. Active fishing lines can be stretched on deck. Another safety issue is getting in and out of the checker pen. Boards can be thick and high, and getting in and out can be dangerous as the vessel is rolling. The crew will most likely be processing the pile with fish picks, and will be processing kept fish with knives.

Gear Information

Types of Trawls

Otter Trawl

The otter trawl is an active fishing gear that is towed through the water column, targeting benthic and pelagic species. It is constructed of twine webbing, so that when fully assembled and rigged, it will take the shape of a funnel while being towed along the bottom of the ocean (bottom otter trawl), or in the water column (midwater otter trawl). Floats on the headrope and a weighted footrope are used to keep the mouth of the net opened vertically. For nets being towed by a single vessel, the mouth of the net is held open horizontally by attaching each wing to an otter board or trawl door. Each door is fitted with chains that attach to the ground cables, which lead to the net. The doors are also attached to the towing vessel via steel cables, referred to as wires or warps. The resistance created by the forward motion of the doors in the water forces them to pull apart, opening in opposite directions, thus keeping the mouth of the net open.

The codend is the bag at the terminus of the net, comprised of heavy twine. The targeted fish collect in the codend, as the net is towed along the bottom at a typical speed of 2–5 knots. The depth of the net is controlled by increasing or decreasing the wire lengths. After a period of time spent fishing, the net is hauled back using hydraulic winches. The length of a tow depends on the vessel size, target species, fishing gear, and area fished, and is typically 30 minutes to several hours in duration. Once the net is hauled on to the fishing vessel, the catch is dumped on deck by releasing the codend via a slip knot or a pucker clip, which holds the codend closed as it is being towed.

Specialized gears may be used and/or required in certain fishing areas. Examples of specialized gear are Haddock Separators, Flounder Trawls, and Eliminator Trawls, to name a few. It is important to remember when encountering these types of specialized gear, to not only verify with the captain, but for yourself. Visually confirm specific modifications (separator panel, escape outlets, large mesh, etc.) as the gear is hauled, or ask the captain to point them out to you. Specialized nets may have different levels of catch and bycatch, but should be sorted and processed the same way as standard nets.

Twin Trawl

Two or more small trawls can provide the same towing area as that of one single trawl, while reducing the drag. This improved efficiency is the driving force behind the adoption of multi-rig trawl gear. The twin trawl principle of covering a wider area works most effectively when targeting groundfish species such as flatfish, monkfish, and shrimp.

Twin trawl nets can be connected via a clump or sled, as the vessel tows two doors. Alternately, the nets may not be connected at all, and the vessel tows two separate nets, each with their own set of doors.

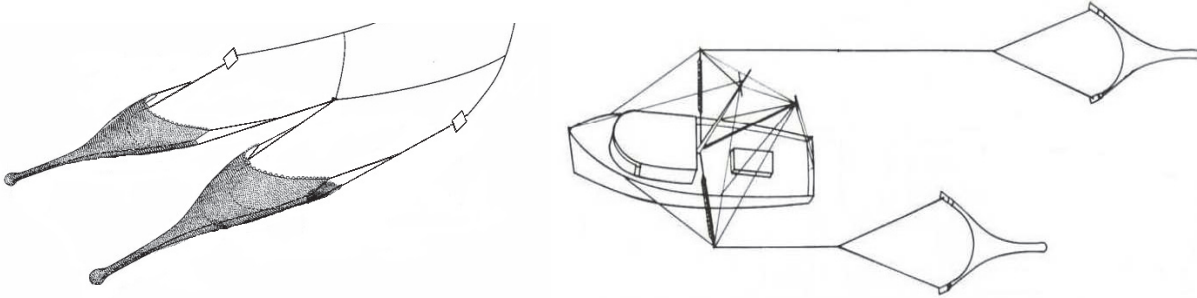

Figure 20. Twin trawls with nets connected (left) and not connected (right).

Scallop Trawl

Scallop trawlers generally use otter trawl nets to target sea scallops. Some vessels will tow two nets, similar to a twin trawl. See the Scallop Fishery section for more information on this type of gear.

Mid-Water Trawls

Mid-water trawls are similar to otter trawls, but are used to target species that run in schools near the surface of the water, such as mackerel or herring. A single midwater trawl gear is pulled by one boat and uses different trawl doors, designed to hold the mouth of the net open higher in the water column, as opposed to sliding across the seafloor (see Figure 21).

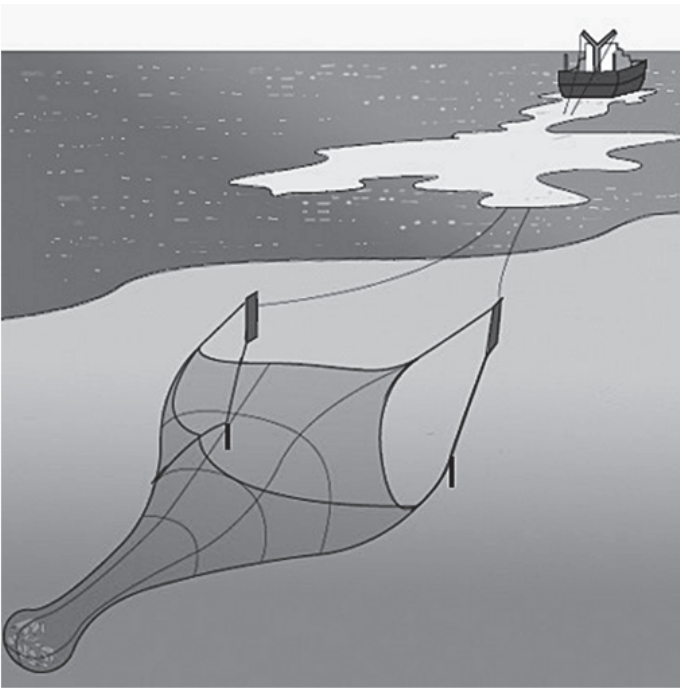

Figure 21. 4-seam single midwater trawl.

Some larger nets targeting schools of fish (herring and mackerel in particular) are towed by two vessels (see Figure 22). Towing a net using two vessels allows for an engine power equivalent to the combined horsepower of the pair. A pair of trawlers may tow a net nearly twice as large as one towed by a single vessel, and can fish

a much wider area than single trawlers twice their size. The long warps on either side of the net guide, or herd, the fish toward the mouth of the net.

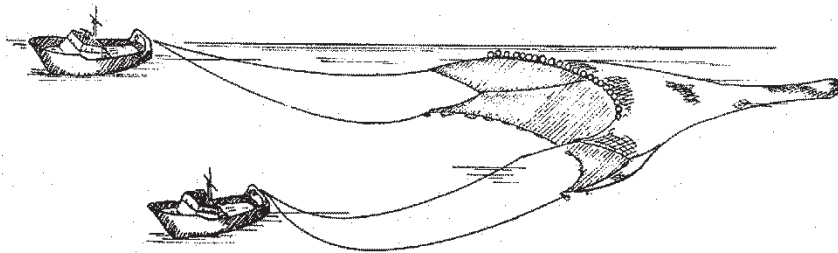

Figure 22. Small boats pair trawling in mid-water.

Pair and single mid-water trawl nets share many of the same characteristics. These large nets can be built in various configurations of netting panels (see Figure 24). The wings are generally made of very large meshes to reduce drag, but can also be made of parallel ropes to decrease water resistance even further (see Figure 23).

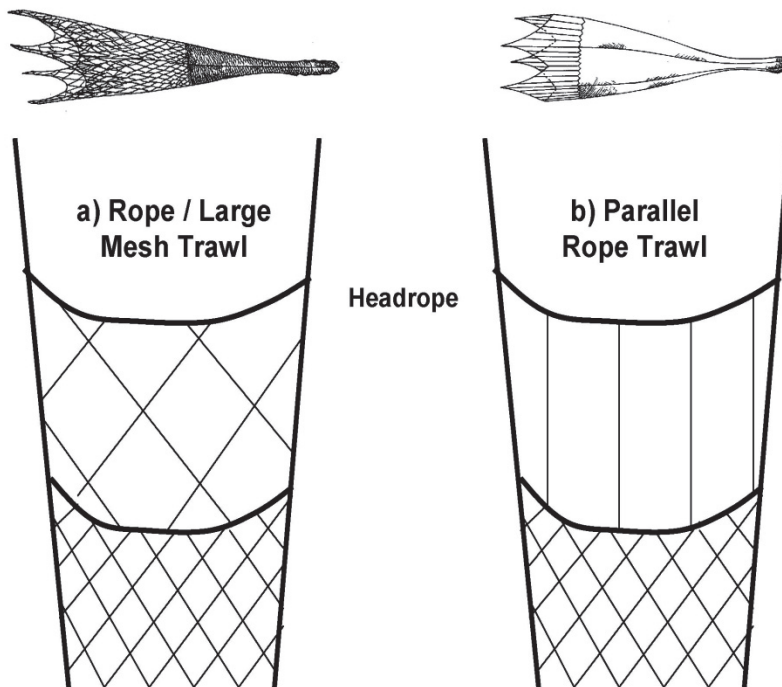

Figure 23. Examples of mid-water nets designed with large meshes (a) and parallel ropes (b).

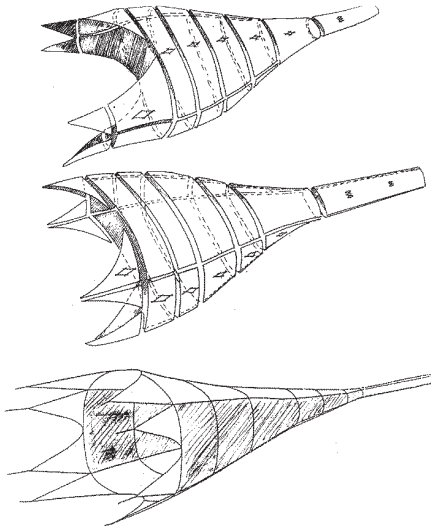

Figure 24. Various configurations of midwater trawl net panels. Top: 2-seam net. Middle: 4-seam net with unequal panels (sides are equal, top and bottom are equal, but sides are not equal to top and bottom). Bottom: 4-seam net with equal panels (sides and top and bottom all equal).

Transducers are often used on the headrope, and sometimes on the footrope or bridles, to monitor the gear configuration. The number and arrangement of bridles and warps can vary greatly (see Figure 25).

		Bridles/Warp	Bridles/Side	Warp/Boat
a)		2	2	1
b)		0	0	2
c)		1	2	2
d)		2	4	1
e)		2	4	2

Figure 25. Pair trawl rigging designs showing bridles, warp, and boat relations. Bridles shown in red and warps in blue.

See the High Volume Fisheries section for more information on observing mid-water gear.

Mesh Sizes

The size and orientation of the mesh affects catch selectivity (see Figure 26). Generally roundfish are targeted using diamond mesh, which stretches in a long, thin shape when towed. Flounders, on the other hand, are typically targeted with square mesh nets; the square mesh retains its shape while towing, which prevents the flatfish from exiting but can allow certain sized roundfish to get through.

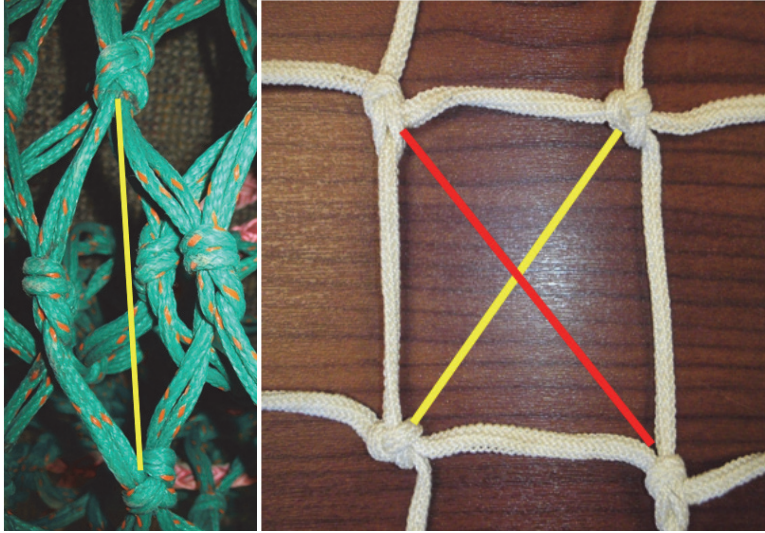

Figure 26. Diamond (left) and square (right) meshes. Colored lines indicate direction of mesh size measurement.

Mesh size regulations vary widely by fishery, area, and time of year. Each vessel may have more than one net or codend that can be swapped during the course of the trip to target different species. Mesh size can change within a net as well. Damaged and repaired meshes will be slightly larger or smaller than the original. A new net may be stiffer and have less variability. The act of fishing can stretch out the meshes, especially with very large catches. Conversely, a net that is left on deck during the winter can freeze, causing the meshes to stretch very little until thawed.

All these factors are important to keep in mind as you measure the codend and liner (if present) mesh sizes. Specifically:

- The net must be empty.
- The net should be laid flat on deck, not hanging from the net reel; ask the captain to lower the net for you.
- Measure the top side of the codend.
- Count at least 5 meshes up from the terminus of the codend and 5 meshes in from the side seam.
- Measure no higher than 20 meshes from the terminus (target the 15 meshes after the 5- mesh buffer).
- Measure only meshes that are unbroken (not mended).
- Measure meshes inside knot-to-knot in the direction the net is hung (see Figure 26).

The importance of mesh size accuracy

Accurate mesh measurements are essential when monitoring fisheries successfully. Most bycatch analyses stratify trips into groups with similar characteristics, one of which is mesh size. Mesh categories can be used to define fishing fleets, determine the proper amount of observer coverage necessary to monitor bycatch, and analyze the performance of different gear types.

- Frozen codend measurements should not be taken (comment if net is frozen or partially frozen).

FSB issues Vernier calipers² for measuring mesh sizes, using the inside jaws (see Figure 27, #2). Measurements must be taken while wearing gloves, and the mesh should be stretched as fully as possible using consistent pressure. Without removing the calipers from the mesh, read the lower slide bar at the “0” line (not the edge of the metal slide). The tick mark on the top ruler that corresponds to the “0” mark on the slide is the mesh size; if your calipers display both millimeters and inches, make sure you read the millimeters ruler.

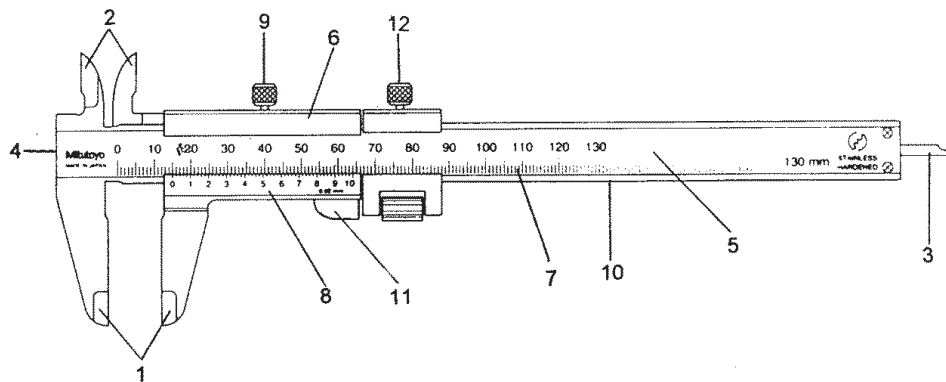

Figure 27. Vernier calipers.

Some trawl fisheries will use a liner inside the codend bag; liners are generally of smaller mesh and may be the same or different material and orientation as the codend. Measure both the codend and the liner, making sure to identify the layers correctly. Some vessels may use three layers of mesh: an inner liner, a middle codend, and an outer strengthener. If in doubt, measure all three layers separately and take pictures.

Other parts of Trawl Gear

Trawls that fish along the bottom will typically use one or more types of ground gear, such as rollers, rock hoppers, and rubber cookies (see Figure 28). These are designed to keep the net from becoming entangled or snagged on rocks or other debris on the ocean floor. Other gears will use a series of drop chains attached to the sweep, which keeps the net just off the bottom, and can exclude some species from entering the trawl.

² The Coast Guard or law enforcement agencies may use a weighted wedge to determine if the vessel is complying with fishing regulations. Observer data is used for scientific purposes, not regulatory compliance.

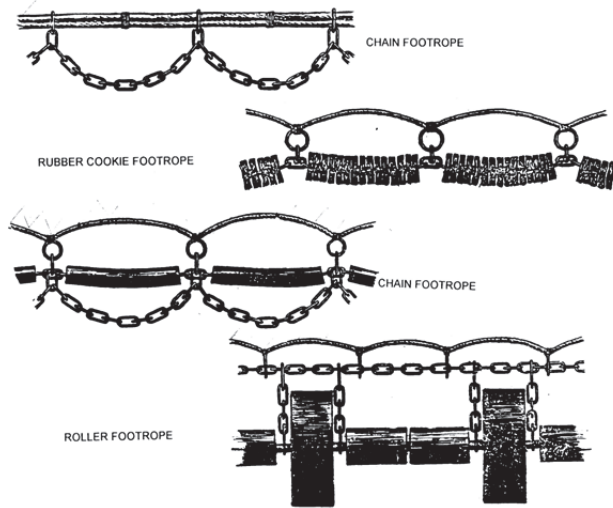

Figure 28. Examples of sweep gear.

Specialized Trawl Net Types

The following is a list of specialized net types that may be observed in the bottom trawl fishery. Other specialized net types may exist that are not included on this list, therefore it is very important to communicate with the captain on the specific type of net fished. **Never assume net types** or any other gear configurations; always confirm with the captain.

Flounder Trawl: May be either (1) A two-seam, low-rise net, where the headrope is at least 30 percent longer than the footrope³ or (2) a two-seam, low-rise net, where the top panel of the net contains a section of large meshes (at least 12-inch mesh) behind the headrope.⁴

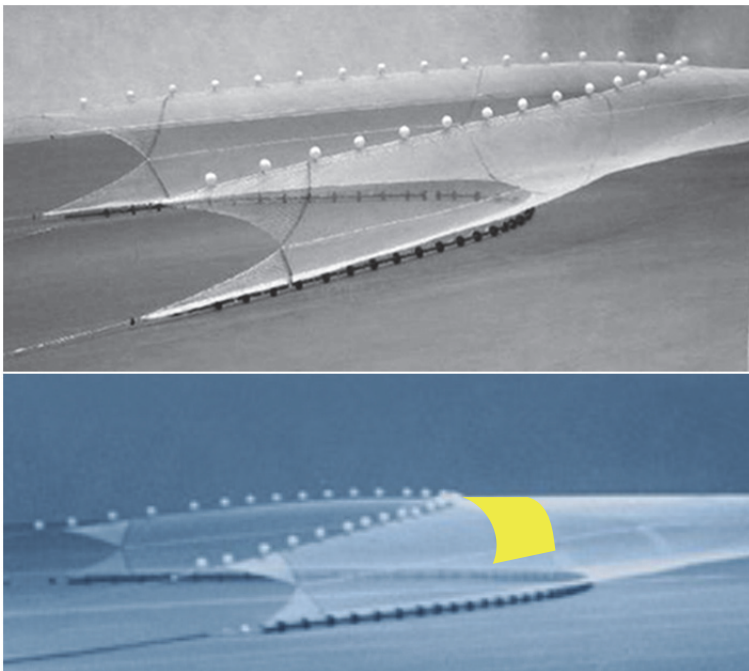

Figure 29. Flounder trawl configurations. Top: headrope longer than footrope; bottom: large mesh panel highlighted in yellow.

Flatfish Trawl: Any net used to target flatfish that does **not** meet the specific definition of a Flounder Trawl (above).

Haddock Separator Trawl: A groundfish trawl with two extensions arranged one over the other. A codend is attached to the upper extension, and the **bottom extension is left open** with no codend attached. A horizontal mesh panel separates the upper and lower extensions.⁵ In some cases, the separator may be sewn shut. Because the trawl is no longer functioning as a Haddock Separator, record it as a bottom trawl (gear code '050'), with no separator or escape outlet. Comment that the separator was sewn shut.

³Modified from 50 CFR § 648.85 (a)(3)(iii)(B)(1).

⁴Modified from 50 CFR § 648.85 (a)(3)(iii)(B)(2).

⁵Modified from 50 CFR § 648.85 (a)(3)(iii)(A).

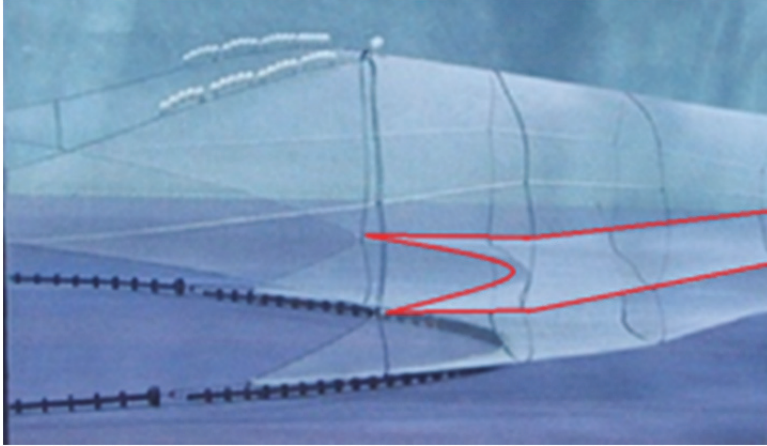

Figure 30. Haddock separator trawl with separator panel highlighted in red.

Ruhle Trawl: A four-seam groundfish net with large meshes (8-foot meshes) in the wings and bottom belly of the net. The trawl must have kite panels that meet the regulated minimum surface area.⁶ The Ruhle Trawl is a specific type of Eliminator Trawl.



Figure 31. Ruhle trawl.

Large Mesh Belly Trawl: A trawl with a large mesh (30-32") installed in the first belly for a total of about 8 feet of large mesh, attached 5 meshes behind the footrope and stretching from gore to gore.

⁶Modified from 50 CFR § 648.85 (b)(6)(iv)(J)(3).



Figure 32. A large mesh belly panel installed in a bottom trawl.

Eliminator Trawl: Typically a four-seam, three-bridle trawl with large mesh in the forward part of the net. Large meshes in the bottom belly act as a separator device for the escape of non-target groundfish species. Mesh sizes decrease as the net tapers towards the codend.

Rope Separator Trawl: A four-seam bottom trawl net modified to include both a horizontal separator panel (consisting of parallel lines of fiber rope) and an escape opening in the bottom belly of the net below the separator panel.⁷

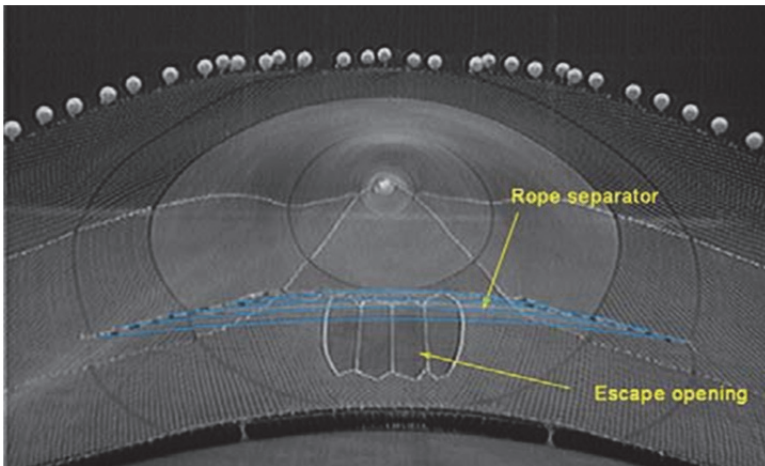

Raised Footrope Trawl: Trawl gear configured in such a way that, when towed, the gear is not in contact with the ocean bottom. Floats attached to the headrope provide lift. No ground gear is used (bare wire or chain sweep), and drop chains (12-inch or 42-inch) may be attached.⁸

⁷Modified from 50 CFR § 648.81 (n)(3)(i)(A).

Sweepless Trawl: A Raised Footrope Trawl in which there is no chain sweep and the drop chains are heavier.

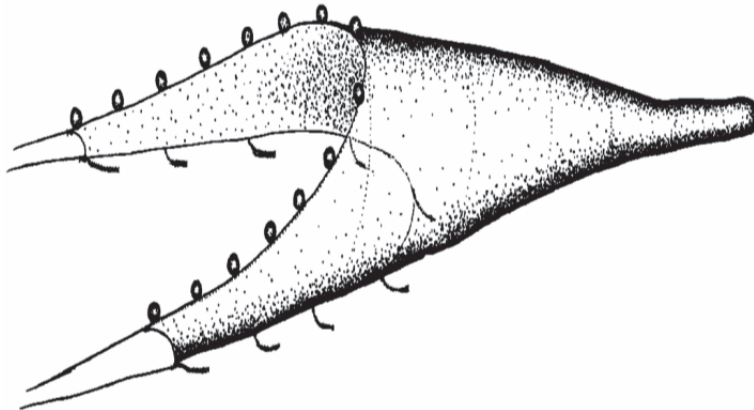

Figure 33. A sweepless raised footrope trawl.

Flynet: A high profiled trawl with large wing mesh sizes that slowly taper to smaller mesh sizes in the body extension and codend. The headrope is usually slightly larger than the footrope. Uses a large number of floats to keep the net slightly off the bottom.

Box Trawl: A four-seam, high-rise trawl.

Shuman Trawl: Contains very large meshes in the mouth and has a very high-opening net that may have canvas kites on the headline to keep the mouth open. Typically fished just off the bottom.

Millionaire Trawl: A four-seam trawl typically used in the squid fishery. Very large openings in the mouth and large large mesh in the wings. May be called “40-footers”.

Balloon Trawl: A two-seam trawl with a high mouth, lighter net material, and floats attached to the headrope so the footrope floats just above the bottom.

Shrimp Trawl: A very small mesh trawl used to target shrimp. Must have a grate consisting of parallel bars that excludes non-target species (see Figure 18).⁹

Observing a Haul

Catch Processing

In the trawl fishery, the catch is brought onboard all at once. The catch is concentrated in the codend, which is either dumped into a checker pen, or directly on the open deck. Several factors affect how you will process the catch: the size of the bag, the vessel set up, the species composition, and how the pile is sorted will affect how you achieve maximum sampling efficiency. The catch can be processed in a multitude of different ways.

⁸Modified from 50 CFR § 648.80 (a)(9)(ii).

⁹Modified from 50 CFR § 648.80 (a)(5)(ii).

Crew members typically pick the kept catch out, and push the discards overboard. Another common method is to pick the kept catch out as it moves along a conveyor belt, while the discards go down a chute and overboard.

The vessel may bring the bag up and determine that it is filled with unwanted catch, which could be due to market or regulations. At other times, the bag may be deemed too large to safely bring onboard. In times like these, the vessel will usually trip the codend and release the entire contents overboard.

Sampling Strategies

Several catch estimation methods can be used to quantify catch. Actual weights can typically be obtained for small species quantities. Tally counts can be used when discards are being tossed overboard individually (e.g., dogfish). Volume-to-Volume may be required when dealing with large volumes of catch, or when crew members are sorting the pile quickly.

The following situations detail some of the more common situations, and describe proper sampling adaptations. In all situations, it is imperative that the catch be sampled while maintaining awareness of what is going on around you. In many situations, the crew may immediately start sorting the pile before measurements and samples have been taken. It is important to communicate with the captain/crew about sampling procedures *before* the first haul. Everything brought up in the gear must be recorded in order for it to be considered an observed haul. Examples are listed below, with suggested methods for appropriately handling the situation:

Small volume of discarded bycatch in haul: Sample all discards completely, and then proceed to sample the kept catch throughout the haul as time permits. Basket and tote counts should be used for kept catch, or captain's estimates if counts are not possible.

Large volume of uniform discarded bycatch: If it is not possible to obtain actual weights for all individuals, use the tally method to obtain an approximate estimated total weight. Representative samples and actual counts of animals discarded are necessary. Basket and tote counts should be used for kept catch, or captain's estimates if counts are not possible.

Large volume of mixed discarded bycatch: Large, mixed hauls typically require the Volume-to-Volume method, especially if the crew is sorting catch quickly. The area of the checker pen(s) should be sketched and measured before the first haul. As soon as possible after the haul is dumped, before any catch sorting, take representative depth measurements and subsamples from throughout the pile. Sorting the subsamples will depend on the catch composition:

Easy to distinguish kept vs. discard: Separate and weigh the subsamples by species and disposition. Extrapolate these weights following standard Volume-to-Volume protocols. If better estimates are later available (e.g., able to weigh all individuals of a species/disposition, able to use basket count method on kept catch), use those estimates, but comment on the Volume-to-Volume extrapolated weights. This comparison can be helpful when evaluating accuracy of estimated weights.

Difficult to distinguish kept vs. discard: Weigh all individuals of each species in your subsample, not separated by disposition. Obtain an accurate estimate (actual weight, tally count, or basket/tote count) for the kept species. Subtract the kept estimate from the total extrapolated weight to calculate the estimated discard weight for each species.

Large volume of kept catch being dumped directly into the hold (typical on bottom trawl vessels targeting Atlantic herring): The vessel will haul back and dump the catch on deck. They will then open the deck plates, and the catch will drop directly into the hold. In many cases, the crew will shovel the catch into the hold through these openings. This poses a problem when using Volume-to-Volume, because you must obtain depth measurements *before* the catch starts flowing into the hold.

Communicate with the captain before the first haul to understand how the vessel operates. If you do not have the time or opportunity to gather depth measurements, or if the vessel is “splitting the bag,”¹⁰ take representative basket samples of the whole catch (beginning, middle, and end of processing), and extrapolate to the captain’s estimated total catch weight, following the catch composition method. If the bag is split, you should spread out baskets as evenly as possible across the splits to ensure a representative sample.

Deckloading: Occurs when the new haul’s catch is dumped on top of a previous haul’s catch. This is common in the redfish fishery, but can occur on any trip. The general method for handling deckloading is to take pile measurements of the pile remaining on deck *before* the next haul is brought up. Then, once the new catch is dumped on top, the total pile measurements should be taken. The new haul volume is estimated by subtracting the remainder volume from the total volume. If discards are low, and actual weights are obtainable, the cumulative sum method can be used.

¹⁰ The crew will section off the codend, dump the contents on deck, close the codend, and continue the process until the codend is empty. The catch is usually dumped on deck with the deck plates opened so there is sufficient room on deck for the next section to be dumped.

Notes

High Volume Fisheries

Definitions

Operational discards: Fish that cannot be pumped, and remain in the net at the end of pumping operations.¹¹

Slippage: Unobserved catch, i.e., catch that is discarded prior to being observed, sorted, sampled, and/or brought onboard the fishing vessel. Slippage can include the release of fish from a codend or seine prior to the completion of pumping, or the release of an entire catch or bag while the catch is still in the water.¹¹

On-effort: The observer is intentionally present to witness discards during the haul back.

Purse Seine

Purse Seine: A wall of netting equipped with rings (purse rings) along the lower edge, with a cable passing through these rings enabling the fishermen to close off the space surrounded by the net from below (see Figure 34). A single gear is composed of the seine (net and bunt) with an attached floatline and leadline, connected along the bottom with rings to a purse line.

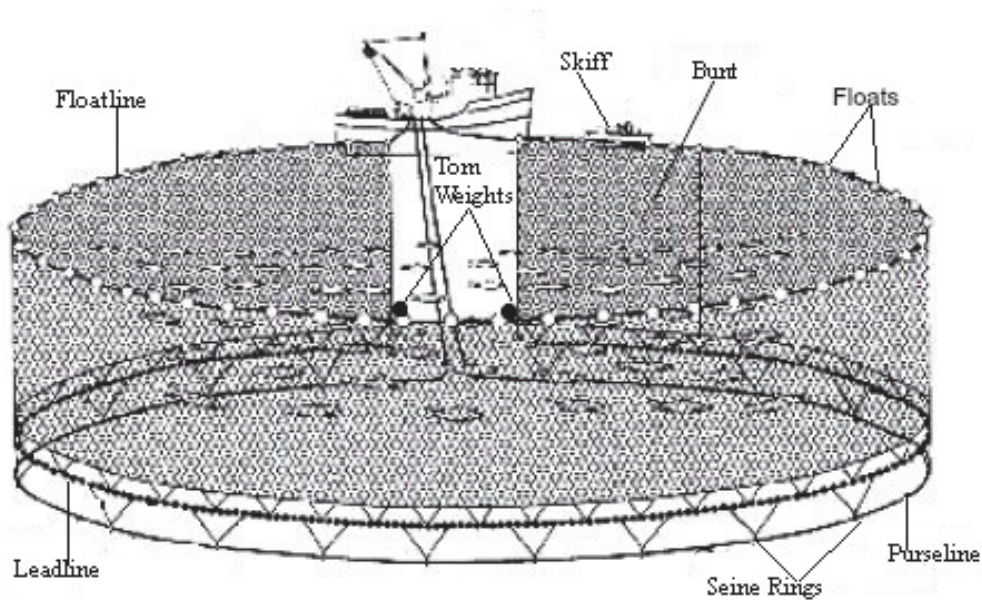

Figure 34. Parts of a purse seine. Source: http://www.iccat.int/Documents/SCRS/Manual/CH3/CHAP%203_1_1_PS_ENG.pdf, modified by FSB.

Purse line: The cable passing through the purse rings which, when drawn on, cinches the lower portion of the net closed.

¹¹ Based on Amendment 5 to the Atlantic Herring Fisheries Management Plan.

Bunt: A section of smaller mesh sewn into the net in the middle, or at either end, which forms a bag-shaped pocket for trapping fish during hauling. Also referred to as the “sack”.

Tom weight: A special sinker used to reduce the gap between the wings of the seine during the pursing stage. Also used to get the net to the bottom faster.

Power block: A wheel or pulley system used to haul in the purse seine.

Triplex: A triple roller winch system used to haul in the purse seine.

Safety concerns

These nets haul hundreds of thousands of pounds of fish. Since the net can't support this weight, vessels in the high volume fishery use thick ropes to take tension off the net. These high tension ropes run across the deck. Be aware of these ropes at all times. Find a safe place, away from these ropes, to set up a workstation, as well as an area to collect subsample baskets.

In addition, be aware of the pumping equipment. The hydraulic pumps used in this fishery are extremely heavy. Stand clear of the pump as it is being raised into/out of the net. Also, the industrial strength hoses that pump the fish have a high amount of stress on them; stand at a safe distance, in case the hoses leak or break suddenly.

Lifting correctly is another important safety issue in this fishery. Fish being pumped onboard come down chutes at a high velocity, and baskets can fill within seconds. A flush basket weighs about 80 pounds. If you cannot lift a full basket, ask the crew for assistance, or fill the basket using smaller amounts, until the basket is flush to the top.

During pumping, a large amount of catch mixed with seawater is being brought on deck. Wear appropriate gear on deck (e.g., oiler pants and jacket, boots, gloves and PFD). To reduce tripping, falling, or other serious injury, try and keep balance by shuffling slowly on deck.

With purse seining, the seine itself takes up a lot of room on the stern, and workspace may be limited. The skiff usually sits on top of the seine at the stern and has a high tension cable attached to it; stay in the wheelhouse during set. In addition, the snaps on the gear (usually made from steel or iron) are about 20-30 pounds each. These snaps swing loose while the crew is “flaking” the net after setting and should be avoided.

Gear Information

The High Volume Fisheries are defined by large catches of many small fish, which are typically pumped onboard using a high powered vacuum pump. Catch flows directly through a series of chutes in refrigerated sea water tanks in the holds. This flow can be as fast as 5000-7000 pounds per minute. Typical target species are Atlantic herring, Atlantic mackerel, and Atlantic menhaden. Common bycatch includes river herrings (alewife, blueback herring, and shads) and groundfish such as haddock.

Vessel are typically large (80-100 feet or more in length), and trips can last for several days, though much time can be spent searching for fish via electronic sounders.

See the Trawl Fisheries section for general information and definitions related to trawl nets.

Paired Midwater Trawl

This fishing method is possible only in relatively good weather, due to the nature of the fishing process, which requires the vessels to maintain uniform distance while towing. In addition, the two vessels need to come close together for hauling the catch or setting the net. To avoid frightening and dispersing targeted fish, the vessels do not travel across the schools, nor do they tow their warps through them. One of the disadvantages to fishing with two vessels is that they need to be of similar size and power, and the captains must work in close cooperation for successful fishing to occur.

Setting begins with one vessel putting the net over the stern. The second vessel then approaches, pulling alongside its sister ship to retrieve a line attached to the net bridle from the vessel setting the net. The receiving vessel will then attach the bridle to their steel wire and, at the specified signal, both vessels begin to pay out a certain amount of wire in unison. Communications throughout the operation are maintained over VHF radio. Once the wire is paid out, towing begins, with the vessels on parallel courses and about one half to one third the warp length apart.

Depth can be modified by increasing or decreasing wire length and towing speed. Other methods of adjusting the net depth include towing closer together or further apart than standard “half-warp” distance.

The vessels rely heavily on their sonar systems (sounders, fish finders) to locate the targeted schools of fish. In addition, sensors are used on the gear, to ensure the gear is fishing correctly and to monitor the catch in the net.

Haul back begins at a given signal, with the warps being pulled in until the legs are brought up to the vessels. The vessels come alongside each other once more. One of the vessels releases its cable and throws the line attached to the net bridle back to the hauling vessel, and the net is brought alongside at the surface to have the catch pumped onboard, into refrigerated salt water tanks.

Purse Seine

Purse seining involves the use of a seiner vessel and skiff working in cooperation to encircle dense aggregations of schooling pelagic fish. Some fisheries will use spotter planes to locate fish aggregations near the surface. This gear is very efficient at targeting shoaling species, with minimal to no impact on the bottom when fished properly.

Nets are very large (700-2100 feet on surface), and set in a circular pattern around the desired school of fish. One working vessel (typically a skiff) deploys the net from the aft region to surround the fish. The purse is then closed by hauling on the purse line, which is fed through a series of rings along the bottom of the net. As the net is pursed closed, the fish are corralled into a small area, and pumping can begin (see Figure 35).

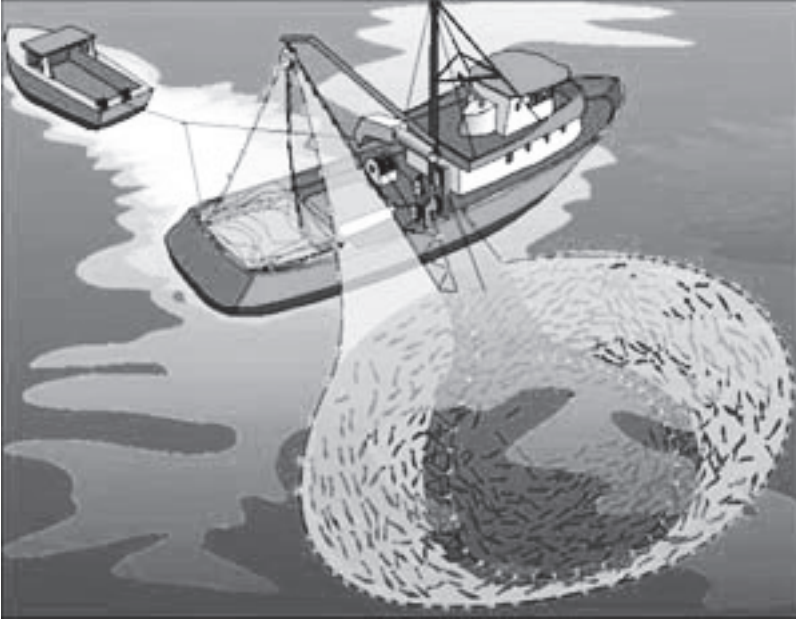

Figure 35. A purse seine net being pursed closed. Source: http://www.gma.org/herring/harvest_and_processing/

Observing a Haul

Catch Processing

Sampling Strategies

Due to the sizes of the catches, the commonly used estimation method in the High Volume Fisheries is Catch Composition. It is necessary to obtain basket samples from all portions of the catch each haul, in order to properly quantify the amount of fish caught. Catch composition also accounts for stratification that may occur within the net. You must have access to no less than 15 baskets (combination of yours and any available on the vessel) to accommodate any sampling situation. It is also imperative to properly maintain your equipment and carefully weigh subsampled catch to assure the most accurate data possible. When possible, digital Marel scales should be used on all High Volume trips (see Marel Scales). Most midwater trawl vessels carry a Marel scale onboard permanently, confirm with your observer provider or FSB staff. Report any issues with the scale to FSB staff immediately.

After the pumping process is completed, visually estimate any catch remaining in the net, and record the presence of larger or protected species in the codend or bunt. You should be able to see the act of the pump being detached from the codend to document any catch discarded. Make sure you have your digital camera on hand to document any operational discards, slipped catch, incidental takes, or large species that cannot be brought onboard for species identification. Ask the captain to bring the codend on board, if it is not already, so you can see the entire contents of the net.

Scenarios

Observed vs. Unobserved Hauls

The High Volume Fisheries follow the standard definition for observed hauls (all catch is recorded, regardless of disposition), with a few exceptions. Operational discards do not make a haul unobserved, even if accurate weights cannot be estimated for what is left in the net at the end of pumping. In these fisheries you will always record any discarded catch data, even on unobserved hauls.

Sample all catch brought onboard your vessel, regardless of whether or not the haul is observed. A complete sample includes basket subsampling, actual weights or tallies of any fish picked at the grate, and visual estimates of any operational discards.

If all the catch is pumped to your vessel and you are able to view and document all catch, then this haul is considered observed. If some or all of the catch is released or pumped to another vessel, the haul is considered unobserved. You should be on-effort for every haul of a High Volume trip, even if those hauls are unobserved.

Before deploying, inform the captain that you need to be able to view the codend or bunt at the end of each haul to verify the presence/absence of operational discards, as well as any interactions with protected species.

Comments describing all discarded catch are required. These comments should include:

- All discarded species. This includes fish brought onboard then discarded (e.g., dogfish picked at the grate then discarded) as well as those released directly into the water.
- Quantify each discarded species. This is especially important for discarding events involving operational discards, fully or partially released catch, and catch brought onboard then discarded (e.g., shoveled overboard after releasing on deck).
- Specific ID characteristics describing how the observer identified discarded species. This is specifically for fish released into the water that was never brought onboard.
- Details of how the observer estimated the amount of discarded species.
- Why species were discarded (e.g., gear problems, operational discards, non-desired species).

Example

The codend comes next to the vessel but is still submerged in the water. All catch is pumped onboard. The captain lifts the codend out of the water to uncouple the pump and observer is able to view the remaining contents. A relatively small amount of fish from the net is released into the water as the pump is removed (“operational discards”). You are able to visually estimate this to be approximately 80 lbs.

This haul is considered observed, and all catch (both kept and discarded, including the catch released from the codend) are recorded. Because you do not know the exact composition of the released catch, record it as “Fish NK”, but provide comments related to any species or groups you can identify.

Catch may be released before coming onboard, either partially or fully. A partial release involves a portion of the catch coming onboard and the rest discarded into the water without coming onboard. In a full release, all catch is discarded; none is brought onboard.

Example

The codend is hauled back and the catch is immediately released back into the water before any pumping begins. This haul is considered unobserved. You should provide comments on the reason for the release (gear malfunction, undesired species, etc.), an estimated weight for the entire bag, and any species or groups you are able to identify.

Example

The codend is hauled back and the pumping process begins. After part of the catch is pumped, the pump breaks and eventually the captain releases the rest of the catch back into the water. As you look over the side, you see a large patch of small silver fish floating on the surface with a dozen larger fish floating among them, that you can identify as striped bass, based on their shape, coloration, and unique striped pattern.

This haul is considered unobserved, and you should provide detailed comments on the reason for release. You should also provide estimates for the striped bass and the rest of the discards ("Fish NK", with a comment that they appeared to be herring-bodied fishes).

Pair Trawl - One vessel observed

If there is no observer on the paired vessel, you will have to communicate with the captain of the other vessel to obtain gear information. You should make every attempt to obtain codend and liner mesh measurements from the other vessel's gear, if used, after the trip. You should record all kept catch from both vessels, as well as any discarded catch you can see.

Pair Trawl - Both vessels observed

If there is another observer on the paired vessel, you will each record all gears and hauls on the trip. You will have to coordinate with the other observer to obtain their gear information and measurements, which will be copied onto your trip with appropriate comments. Both observers will collect haul information independently; do not copy any haul information from the other observer. Only document kept and discarded catch from your vessel; the other observer will be responsible for their vessel's catch. If there is slippage or a large discarding event, both observers will document any details they can observe. Communicate with the other observer to ensure discards are not being double counted.

Example

The codend is hauled back and brought alongside the vessel. Catch is pumped to both vessels, both of which have an observer onboard. There are no operational discards left in the net, and the net is brought onboard after the pumping is complete.

The haul is considered unobserved for both observers, and both will include a comment that catch was pumped to another vessel, including the vessel name. You will both sample all catch pumped to your vessel and record all catch (kept and discarded) on/from your boat. After the trip, you should contact the other observer to make sure you have not duplicated data.

Purse Seine

The captain will determine if a set is successful, and/or if any fish were lost. In some cases, a significant amount of the targeted school will not be captured due to gear or operational malfunction. Fish lost are not considered discards, and not quantified in the observer trip records. Hauls with fish lost can still be observed, if all other requirements for an observed haul are met.

Examples of fish lost

Floatline sank below water line and fish escaped over it.

Operator or gear malfunction, and part of the school was not encircled as a result.

A whale or large species is encircled in the set. The net is released to allow the animal to escape.

Notes

Scallop Fishery

Definitions

Limited Access: A category of scallop vessels that hold a certain type of permit. Trips are generally multiple days, up to two weeks, and go farther offshore.

Limited Access General Category: A category of scallop vessels that hold a “general category” permit. These are typically “day” boats, with trips lasting less than 48 hours, and are limited to fishing closer to shore.

Scallop Dredge: A frame that is towed by a vessel to collect sea scallops on the ocean floor (see Figure 36). A cutting bar is on the bottom of the dredge frame, and a chain bag for scallop collection is on the top. A club stick is attached to the end of the chain bag. There are two main types of dredge frames; Standard and Turtle Deflector Dredge.

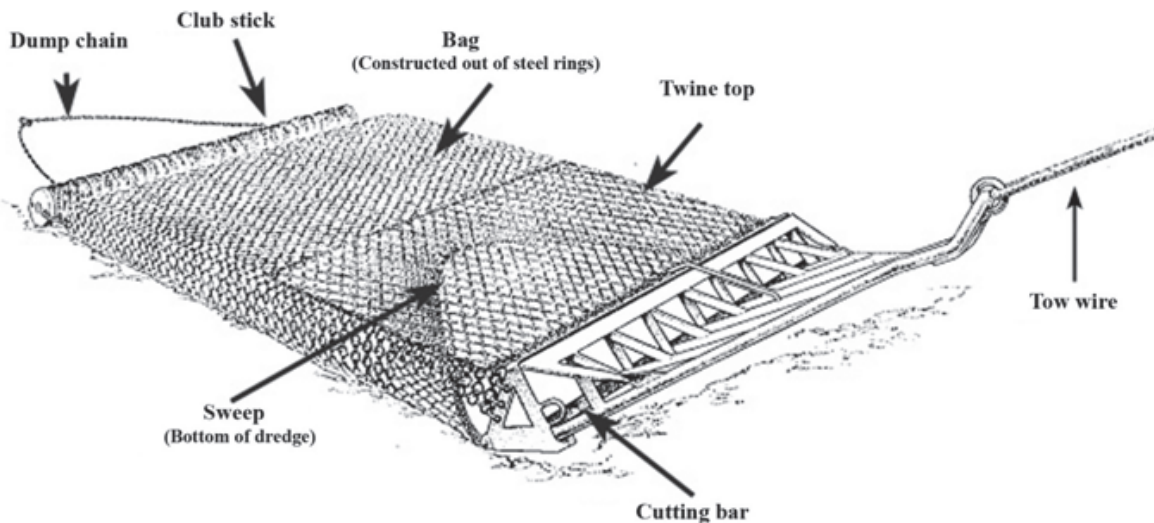

Figure 36. New Bedford style scallop dredge.

Standard Dredge Frame: A steel, triangular-shaped frame with a cutting bar, bale bars, and pressure plate. The pressure plate is mounted along the top of the frame and the cutting bar runs along the bottom of the frame. Generally, the upward-most angle of the pressure plate is located directly above the cutting bar, creating a straight line (frame height).

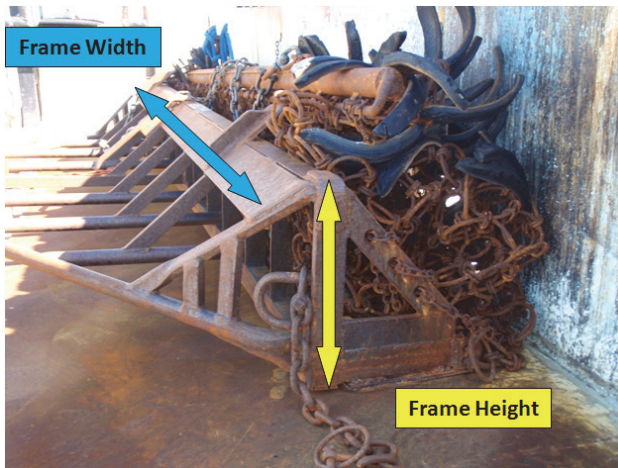

Figure 37. Standard scallop dredge frame showing height and width dimensions.

Turtle Deflector Dredge: Any frame where the following characteristics are met (see Figure 39):

- The cutting bar is located in front of the pressure plate.
- The angle between the front edge of the cutting bar and the top of the dredge frame is less than, or equal to, 45 degrees.
- There are no bale bars present, with the exception of the outer bars (single or double) and the center support beam, creating an otherwise unobstructed space between the cutting bar and the forward bale wheels, if present.
- The center support beam must be less than 6" wide.
- All dredges with a width 10'6" or greater must have a straight extension ("bump out") that is larger than 12" in length and connects the bale bars to the frame.
- For the purpose of flaring and safe handling of the dredge dredge, a small appendage (rod or "U" shaped), no part of which may exceed 12" in length, may be attached to the outer bale bar on each side of the dredge. It may not be closer than 12" to the cutting bar, as to avoid interfering with space created by the "bump out."
- Struts must be spaced no more than 12" apart from each other.

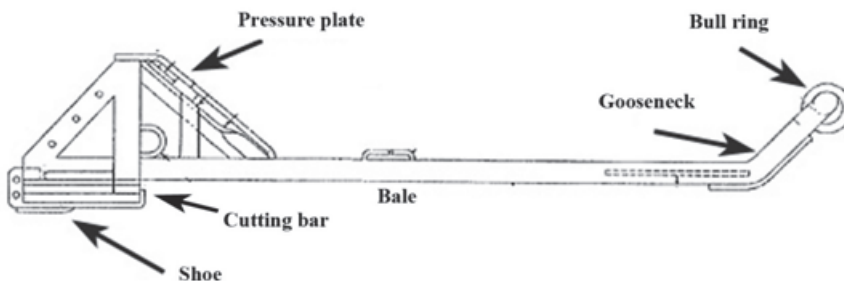

Figure 38. Parts of a scallop dredge frame.

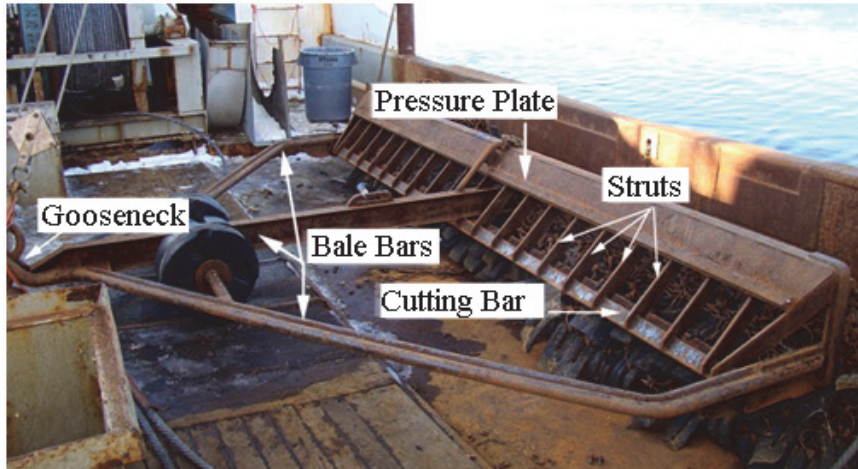

Figure 39. Turtle deflector scallop dredge.

Cutting bar: A piece of steel welded along the bottom of the dredge frame that helps pick up scallops off the sea floor.

Pressure plate: An angled piece of steel welded along the length of the top of the dredge frame. It uses downward pressure created by towing to keep the dredge on the sea floor, and helps the cutting bar make contact with scallops.

Shoe: Pieces of metal that are welded onto the bottom of the frame, under the cutting bar. They provide a buffer between the frame and the sea floor. These wear down throughout the course of a trip, and are frequently replaced.

Club Stick: A device that holds the shape of the dredge while it is towed, and helps with dumping the dredge on deck.

Bale Bars: Steel supports that run perpendicular to the dredge frame. One side of the bale bar is welded to the cutting bar, and the other side to the triangular frame.

Gooseneck: Steel end of the frame that connects the dredge to the tow wire and the vessel.

Twine top: Woven mesh panel on the top of the frame, as it is fishing on the sea floor. Generally hung from rings or chain links, which connect it to the frame. Helps finfish to escape from the gear.

Apron: Bottom of the chain bag where the catch is retained (see Figure 40).

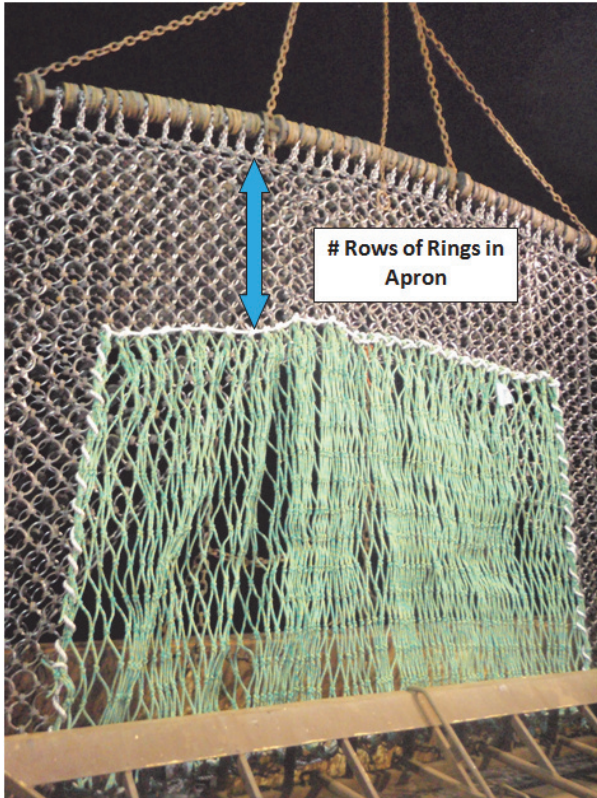

Figure 40. Scallop dredge apron.

Skirt: Section of rings that connect the twine top to the dredge frame.

Chafing Gear: Material attached to the bottom/apron of the chain bag used to “stir up” the bottom and aid in the collection of scallops. This can be “horse hair” or pieces of rubber.

Chain Bag: Collection area of a dredge composed of chains (“mat”) and mesh. “Rock chains” run vertically (perpendicular to the frame). “Tickler chains” run horizontally (parallel to the frame). Rock and tickler chains can be connected to each with shackles or links, or can be separate from each other. There are two configurations of chain mat: Turtle Chain Mat and Standard.

- *Turtle Chain Mat*: A modified chain arrangement composed of connected rock and tickler chains, configured such that the openings formed by the intersecting chains have no more than four sides, and each side may not exceed 14” in length (see Figure 41). The chains must be hung to cover the opening of the bag, such that the rock chains extend from the back of the cutting bar sweep.
- *Standard Configuration*: Chains may not be present, may have openings greater than 14”, and/or may not have 4 sides. Intersection points are not always connected. Grid openings can be inconsistent. “Spider chains” are an example of a standard configuration where the number of rock chains between each tickler chain varies, creating a “web-like” pattern.

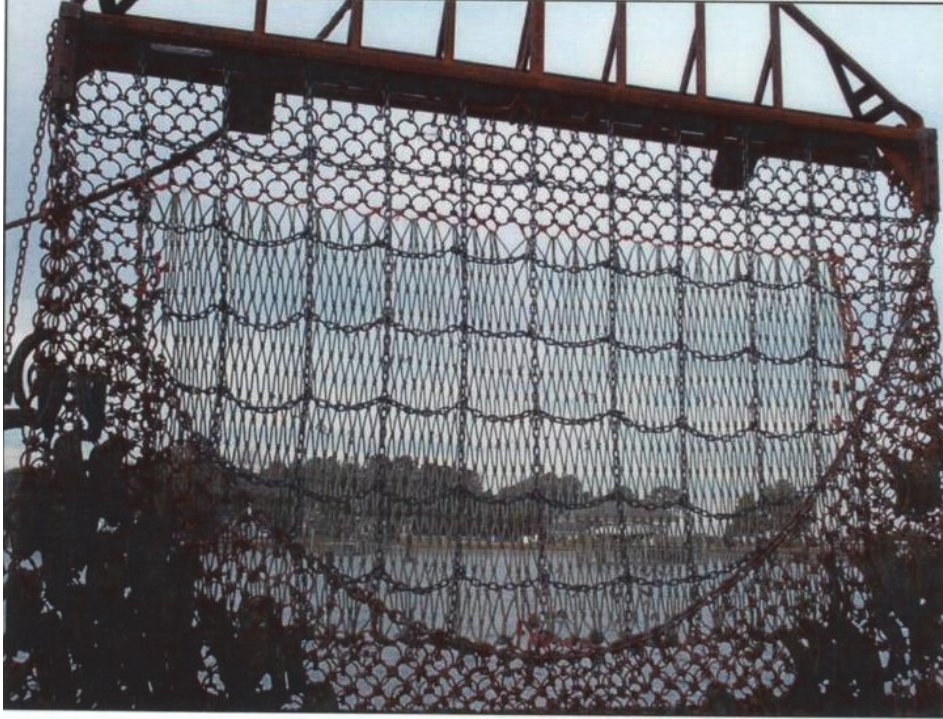

Figure 41. Scallop dredge with turtle chain mat.

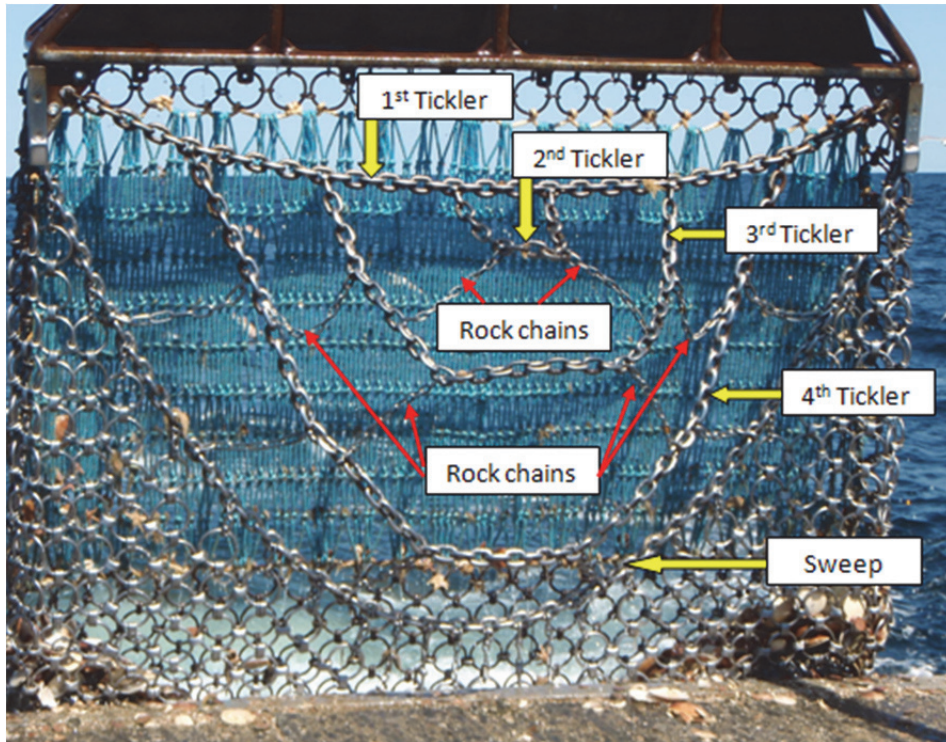

Figure 42. Scallop dredge with spider chain mat.

Deckloading: Occurs when catch from multiple hauls are dumped on top of each other.

For scallop trawl gear definitions, see the Trawl Fisheries section.

Safety concerns

Dredges swinging overhead can be a serious safety issue. You should never be on deck while the dredges are being hauled or deployed. Caution must also be exercised around wires and winches on deck. There is usually a good location on the back deck of the wheelhouse where the setting and hauling processes can be observed.

Gear Information

The fishery for sea scallops in the US is a limited access fishery, i.e., no new permits are being issued, but they may be bought and sold on the open market. The fleet is divided into two broad permit categories: Limited Access (LA) vessels and Limited Access General Category (LAGC) vessels. The majority of scallop landings are from the LA fleet, which are larger vessels (approximately 80-120ft) that spend multiple days at sea per fishing trip. These are often referred to as “trip” boats. The LAGC vessels are typically smaller (40-60ft), often fish scallop resources closer to shore, and will only go fishing for 1-2 days. These vessels are referred to as “day” boats.

Two types of fishing gears are most commonly used to harvest scallops: the scallop dredge and scallop trawl.

The major dredge components include a dredge frame, dredge shoes, pressure plate, cutting bar, chain sweep, chain bag, and a twine top mesh panel that allows fish bycatch escapement. Dredge ring sizes and twine top meshes must meet minimum sizes as specified by regulations. Many vessels deploy two scallop dredges to fish at the same time, with one on each side of the vessel. The maximum dredge width is also regulated; typically maximum width is a combined 31 feet for LA vessels and 10.5 feet for LAGC vessels, or vessels in the small dredge program. The traditional dredge frame is called a New Bedford style dredge. These dredges have multiple bale bars supporting the dredge; when fishing in hard bottom substrates, they will often be rigged with tickler and rock chains. These chains crisscross the opening of the chain bag in order to keep large boulders out of the dredge, and to stir up the bottom to increase catch.

Regulations may specify which type of dredge or chain configuration can be used in certain areas and time of year. However, you should be prepared for any situation, as regulations can change or vessels may be fishing under exemptions or experimental projects.

The offshore, or New Bedford-type dredge ([Figure 1](#)), is used by a good portion of the scallop dredge vessels fishing in waters

Scallop life history

Atlantic sea scallops are broadcast spawners with eggs fertilized externally in the water column; adult females can release 270 million eggs per year. After a brief period of settlement, fertilized eggs develop into free swimming larval stages that can swim and drift in the water column. Settlement of spat occurs after 1-2 months. Scallops can be active swimmers to avoid predators or find more suitable habitat. Tagged scallops have traveled as far as 48km in a 2-year period. Scallops may live up to 20 years of age. Scallops are filter feeders, straining suspected phytoplankton, zooplankton, and organic matter from the water column.

Atlantic sea scallops inhabit US waters, including the area of the Gulf of Maine, Georges Bank, and the Mid-Atlantic Bight. Large aggregations of scallops are referred to as “beds.” They can occur in shallow coastal waters in northern New England and Canada where waters are cool, but also throughout the Northeast U.S. continental shelf as far south as Cape Hatteras, North Carolina. Although they have been reported in waters exceeding 110 meters, they are most commonly found at depths ranging from 45-75 meters. Sea scallops are found in the highest concentrations on sand, gravel, or shell-hash substrate.

deeper than 40 meters. The dredge consists of a heavy steel bale welded to a rectangular frame. The top of the bag (Figure 2) consists of a mesh twine top that allows small fish to escape, followed by a steel ring section called the apron. The bottom of the frame (Figure 3) consists of a rectangular steel cutting bar which rests on steel-plate shoes. The ends of a sweep chain are attached near each shoe. Attached to the top of the frame is a forward-angled pressure plate that aids in keeping the dredge in contact of the bottom when it is being towed. Various chain configurations are sometimes used across the opening of the bag to exclude larger or undesirable objects from entering the dredge bag. The bottom of the bag, behind the sweep chain, is made entirely of steel rings. The rings of the bag are connected using steel links. Different numbers of links may be used for different areas of the bag, depending on wear from substrate and stress on the rings. The number of links between rings also affects selectivity of the dredge. At the bottom of the chain bag, a club stick is attached, which holds the bag's shape and facilitates dumping the catch on deck.

Scallop Fishery Management

Atlantic sea scallops, *Placopecten magellanicus*, are currently the most valuable fishery in the United States. Data from 2013 indicate that sea scallop landings were approximately 41 million pounds, valued at over \$467 million. The vast majority of scallops are hand-shucked at sea, but a small market for live sea scallops is also available.

The Atlantic sea scallop fishery is managed by the New England Fishery Management Council (NEFMC), a regional body charged with conserving and managing fishery resources from 3 to 200 miles off the coast of Maine, New Hampshire, Massachusetts, Rhode Island, and Connecticut. The NEFMC has developed a comprehensive Fishery Management Plan (FMP) for Atlantic sea scallops, and works in conjunction with NOAA Fisheries to develop necessary regulations, and for the collection of scientific data to support timely and proper management. The scallop fishing year runs from March 1st through the end of February.

Observing a Haul

Most vessels fish 24 hours a day, towing two dredges at the same time from hanging blocks suspended from gallow frames on each side of the vessel. Tow duration depends on the bottom type and scallop density, but most tows are between thirty and ninety minutes long. During haul back, each dredge is winched up over the rail using a boom spotted for that purpose. When the dredge frames are on deck, the hook is coupled to the dumping chain attached to the club stick, and each bag is lifted to dump its contents. The bag ends are then immediately swung overboard and the dredge frames are lifted back over the rail and reset. Often, only 5 to 20 minutes elapse between hauling, dumping, and redeployment of the gear.

The crew hand-sorts and culls the catch. Scallops and marketable fish are removed from the catch piles that are created when the dredge contents are dumped on deck. Marketable-sized scallops are placed in plastic bushel baskets and emptied into cutting boxes; sometimes discarded scallops or clappers may be mixed in as well. The remaining discard piles on deck (including unwanted fish and under-sized scallops) are shoveled out the scuppers to clear deck space for the catch of the next haul. To prevent spoilage, the scallops are usually cut at sea. The adductor muscle meat is separated from the viscera and shell, washed in cold sea water, packed in muslin bags to weigh approximately 40-60lbs, and stored with ice in the hold.

Catch processing

General Category trips – All hauls should be observed, with complete catch information for both kept and discarded species, unless the vessel is fishing for an extended period of time (over 12 hours).

Limited Access trips – A minimum of 50% of the hauls should be observed, following a regular watch schedule.

- 8-10 hour watches allow for observing both daytime and nighttime activity throughout the trip.
- 12-hour watches require a shift switch halfway through the trip, accomplished by working two 6-hour watches at the expected midpoint of the trip.

The steam to the fishing grounds can be anywhere from 45 minutes to 24hrs, depending on the targeted fishing grounds. Gear information and measurements can be taken during the steam, with the exception of mesh sizes, which must be taken after the gear has been fished. Communicate with the crew, letting them know that you will need a shucked basket of scallops once per watch, and that you will need to weigh or estimate discards before they kick them out the scuppers.

The crew will either pick the kept scallops out of the pile and into bushel baskets, or shovel the catch into baskets. A good strategy is to pick out finfish and get weights while the crew is sorting the scallops; be sure to get an accurate count of baskets from that haul only (often times there will still be baskets on deck from previous hauls, so be sure to avoid double counting).

Sampling Strategies

For the first haul of every watch, obtain the dressed meat weight and volume for a basket of kept scallops. First, take the round weight and shell height frequencies of all scallops in the basket. Then, ask the crew member to shuck the scallops, and collect the meats in your bucket. See Scallop Sampling for instructions on measuring scallop meat weight and volume. The kept meat weight per bushel will also be used as the average weight per basket for the basket count catch estimation method. This same number is used throughout the watch; if the vessel moves to a different area, changes catch processing methods (e.g., switches from picking to shoveling), or if kept meat sizes change significantly, you should re-take your scallop meat weights.

Ask the crew to notify you if they encounter grey meats and/or parasites (nematodes) while shucking. If affected meats are observed, increase your scallop biological sampling (shell heights, meat weight, and meat volume) to at least two times per on-watch. After shell heights are taken, have the crew shuck and separate the dressed scallops into two categories: the normal kept scallops and any poor quality scallops. Record separate meat weight and volume data for the kept and discarded (grey/parasite) scallops and use that information on all hauls in that watch period until another detailed biological scallop sample is collected. If any changes to scallop catch composition occurs during the on-watch period, you should take a new detailed biological sample. Additional sampling should be done as time allows. Prioritize this extra sampling *after* collecting actual weights per haul but *before* collecting shell heights for kept scallops. If the crew indicates that poor quality scallops are no longer present during a watch period, obtain another detailed biological sample for the “clean” scallops.

If nematodes are observed, freeze 3-4 of the affected meats per watch period in a bag, labeled with the haul information. For watch periods where grey meats are observed, freeze 3-4 of the affected meats in one bag and 3-4 “normal” (white) meats from the same haul in a separate bag for comparison; each must be appropriately tagged. See Submitting Frozen Samples for instructions on bagging and tagging samples.

If the vessel is *keeping* the poor quality scallop meats, the protocols for determining weights of grey/parasite meats per bushel should still be utilized, with a comment explaining the estimated weight of the poor quality meats.

In cases where deckloading is occurring, you may want to use the Cumulative Sum estimation method. See Deckloading: Scallop Fishery for more details on calculations.

Notes

Clam/Quahog Dredge Fishery



Figure 43. An example of stern-rigged dredges on A-frames.

Definitions

Dredge cage: Towed steel frame with a blade/knife on the bottom that passes through sediment and unearths clams/quahogs for retention. May have a manifold attached, which houses nozzles that spray pressurized sea water into the sediment to help unearth clams/quahogs before the blade/knife passes through.

Cage Bars: Bars on the bottom of the dredge.

Nozzles: Present on the manifold section of the dredge; emit pressurized water (see Figure 44).



Figure 44. Example of nozzles on the manifold section of a clam/quahog dredge.

Towline: Nylon line that tows the dredge once it has been set and is actively fishing (see Figure 45). Is able to go slack (compared to tow wire), and allows gear to move over the sea floor without getting snagged and causing damage.



Figure 45. Example of a tow line attached to a dredge.

Chain Bag: Section of the gear that retains kept clams/quahogs (see Figure 48). Smaller, immature individuals are able to fall through the rings that make up the bag.

Sorter: A mechanical sorting machine that helps clear the catch of shells and small debris, before it passes onto the conveyor belt (see Figure 46). Water is often used as well, to help clean sand from the catch.



Figure 46. Examples of different sorting machines used on clam/quahog vessels.

Safety Concerns

There are a number of safety concerns associated with observing clam/quahog dredge vessels. In addition to the loud hydraulics and heavy gear, there are also moving deck plates and open cages on deck. Getting access to the catch, without climbing over the cages, may be difficult. Most vessels have a small walk-way between the center deck space and the sides of the vessel that can be accessed. However, it is important to keep in mind that most clam/quahog vessels have low vessel sides, and sit low in the water.

Vessel stability is another safety concern in the clam/quahog dredge fishery. As cages are filled, a great deal of weight is added to the vessel. In addition, the dredge(s) add a significant amount of weight to the stern of the vessel (see Figure 47). Cages are filled in a particular order to try to off-set the stability concerns, and most vessels do not fish in poor weather conditions, to avoid setting and hauling heavy dredges in less than ideal conditions.

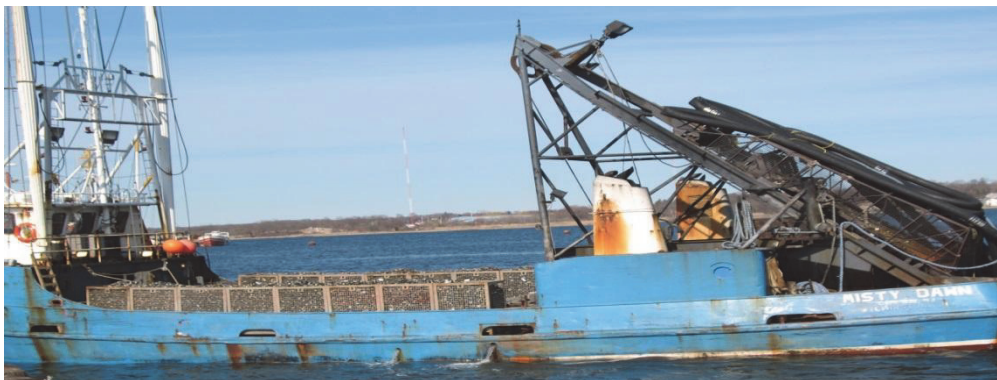

Figure 47. Safety concerns displayed on a clam/quahog vessel: heavy filled cages, low sides of the vessel, large dredge on the A-frame.

Gear Information

The clam/quahog dredge fishery ranges from Maine to North Carolina, but is mostly concentrated in Southern New England, the Mid-Atlantic region, and a portion of Georges Bank. Most trips land in either New Bedford, MA or Atlantic City, NJ.

The major target species for the fishery are Ocean Quahogs and Atlantic Surf Clams, which burrow in a variety of substrates. There is also a smaller subset of the fishery that targets Maine Mahogany Quahogs, which are genetically identical to Ocean Quahogs, but are smaller and found closer to shore.

The clam/quahog fishery is managed under an Individual Transferable Quota (ITQ) system. Vessels may have permits to catch both Ocean Quahogs and Surf Clams, but they are not typically targeted at the same time, as the beds that they are found in don't usually overlap. Clams/quahogs are stored on vessels in standard-size (60 ft³) cages, typically below deck. They are landed round, and offloaded to processing plants.

Clam/quahog vessels range from 60 to 160 ft., and typically fish with one or two dredges. Vessels are limited by the number of cages and ITQ tags they are issued, as well as the amount of time they have to land the

product in good condition. Vessels will fish around the clock, in order to get back to the dock on schedule. Trips are typically 36-48 hours in duration.

Dredges will have either a one- or two-piece design (see Figure 48), meaning that the dredge is either one complete steel cage, or it has a chain bag connected to the end portion of the dredge. The two-piece design is less common in the current fleet, as it is thought to cause more impact on the ocean bottom, and requires more gear maintenance.



Figure 48. An example of a one-piece (left) and two-piece (right) dredge.

Dredges may also be either hydraulic or non-hydraulic. Hydraulic dredges use pressurized sea water to temporarily liquefy sediment and unearth clams/quahogs from the sea bed, before a dredge blade passes through and scoops the catch up. Non-hydraulic dredges do not use pressurized water to unearth clams/quahogs from the sea bed. Instead, the blade passes through the sediment in short, rapid motions and unearths the clams/quahogs. Non-hydraulic dredges are also known as “dry dredges,” and are most common in the in-shore Maine Mahogany Quahog fishery.

Observing a Haul



Figure 49. An example of a conveyor system set up to fill a specific section of cages on deck.

Catch Processing

If they are using two dredges, they will set one completely before setting the other, and then fish them both at the same time. The hose is deployed before the dredge(s). The dredge(s) are deployed off the A-frame(s) using tow wire, then actively towed in the water using nylon towline. Pressurized sea water pumps from the vessel down to the manifold on the dredge via the hose, and pumps through nozzles. This temporarily liquefies the sediment, and allows the knife on the dredge to unearth and scoop up the clams/quahogs.

Smaller individuals fall through bar openings in the bottom of the dredge cage and/or through rings in the chain bag (if used). Tows are typically short in duration. At the end of the haul, winches engage to bring back the tow wire. Dredges are hauled one at a time (if fished together). Once hauled up the A-frame, the bottom of a dredge will be tripped open and the catch dumps into a “hopper.” Dredge(s) will be almost immediately re-deployed.

Once the catch has been dumped into the hopper, it moves through a mechanical sorting machine of some kind (e.g., shaker or tumbler). Water is also typically used in the sorting process – which helps eliminate small debris (sand, shells, sand dollars, etc.). There will be discard chutes dumping the debris at this point.

After going through the sorter, the catch moves along a conveyor belt (see Figure 49). Crew members remove any other unwanted debris, and direct kept catch into the appropriate cages. They fill cages one at a time, and alternate between port and starboard side, to try to maintain stability.

Sampling Strategies

When observing a haul, the best sampling location will be one where you have access to the discards being picked off the conveyor belt, and a view of the catch coming through the sorter. The location of the sampling station will likely vary throughout the course of a trip, as they move deck plates to access different empty cages. You should be able to obtain actual weights on most discard species. Kept catch will be accounted for by converting the number of filled cages into a basket weight.

Notes

Incidental Takes and Protected Species Information

Definitions

Incidental Take: If at any time during an observed trip a marine mammal, sea turtle, or sea bird directly contacts the vessel, or the vessel's fishing gear AND any part of the animal is entangled, snagged, ensnared, caught, hooked, collided with, hit, injured, or killed by the vessel or its gear, regardless of the final condition and release of the animal, it is considered an incidental take. Includes articulated marine mammal, sea turtle, or sea bird skeletons ($\geq 75\%$ of skeleton).

Sighting: A marine mammal or sea turtle observed during a deployment, which you determine not to be an incidental take. An animal must not be double-counted as both an incidental take and a protected species sighting. If a dead or injured marine mammal, sea turtle, or sea bird is seen in the water during, or immediately after a haulback, you must decide if the animal was once entangled in the gear of the vessel, i.e., whether the animal(s) is (are) determined to be an incidental take. Gear or gear marks on the animal and/or damage to the fishing gear may help to distinguish incidental takes from sightings. This information is critical in determining the temporal and spatial distribution of protected species, and the relative abundance and behavior of animals in the vicinity of fishing operations. Seabirds are not recorded as sightings.

Entanglement: The animal's initial situation at the first observation. Includes where and how the animal is trapped/caught in the gear, any gear wrapped around or ingested by the animal, or how/when the animal fell from the gear.

Condition: The status of the animal **when you release it**. If alive, includes any fishing gear remaining on the animal. If dead, includes severity of decomposition.

Per ESA Permit requirements and the FSB protocols, you are required to make every effort to revive all sea turtles incidentally taken during commercial fishing operations that come onboard, and are comatose (unconscious) or inactive. A resuscitated turtle is any turtle that was comatose (i.e., no signs of life; unconscious; non-responsive) and later became active, possibly as a result of placing the turtle into a recovery position.

PSID or PSID #: Protected Species Identification number, sequentially assigned to all incidental takes throughout the trip.

Onboard: It is important to know if an animal was physically brought onboard the vessel, or was released/fell prior to coming onboard.

An animal that is removed from the gear and handled by a crewmember would be considered onboard, regardless of whether it touched the deck (e.g., seabirds removed by hand from trawl gear while being brought onboard, and then returned to the water).

An animal that is cut from the gear but is never handled by a crewmember would not be considered onboard (e.g., a marine mammal cut from a gillnet before coming in contact with the hauler).

Safety Concerns

Protected species, both live and dead, can pose serious safety concerns. Always wear gloves when working with these animals. You should also wear a face shield if there is any possibility of blood or other fluids coming into contact with your eyes, mouth, or skin.

Live cetaceans are very large and powerful and can thrash around violently on deck. Live pinnipeds, while smaller, can still be very powerful, and have sharp teeth and claws. Never attempt to handle live mammals; let the crew take care of getting them off the deck.

Live sea turtles have powerful jaws. Always keep clear of the head and wear durable footwear when working around them on deck. Sea turtles of all species, except leatherbacks, have claws on their flippers. Keep clear of flapping flippers, especially if the animal is on its back. Avoid straddling animals when you are working with them.

Live birds have sharp beaks and claws. Do not attempt to handle these animals yourself; let the crew take care of getting them out of the gear and off the deck. If you do handle a live seabird, keep your face away from the bill (wear glasses or a face guard). See Handling live seabirds for more information.

Dead animals can carry and transmit microbes which may cause illness in humans and other animals. In addition to gloves and face shields, always wash your hands and other areas of contact thoroughly after contact. Wash your sampling gear after each use. Report any animal bite, scratch, or other significant exposure to marine animal blood, saliva, or excretions. Tell your physician that you work with marine animals.

Being Prepared for an Incidental Take

Communication

At the beginning of the trip, explain to the captain what your duties are if an incidental take should occur. It is important to have this conversation every trip, because the vessel may be covered by different programs with different sampling priorities. Do not wait until an incidental take occurs; by that time it may be too late to get all the information you need.

Tag Supply, Distribution, and Tracking

Prior to each deployment, ensure that you have an adequate supply of sea turtle and marine mammal carcass tags. **Always** carry a minimum of five tags of each type, and associated gear for fastening (e.g., zip ties, pliers). All tags should be signed out from FSB staff. You are responsible for all tags issued to you. **Transfer of tags to the vessel operator or anyone else, including other observers, is not allowed.** You should be supportive of other organizations' tag and release programs, and tagging efforts of crew members. Upon separation from the program, all tag types must be returned to FSB. Each group of Inconel tags will normally be packaged with the tag numbers listed on the outside. Documentation of lost tags is very important to help improve tracking of tag resources. Notify FSB of all lost or malfunctioning tags.

If the animal is dead and a tag or band is present, remove the tag (if possible) and send it in with the trip data. If the tag cannot be removed, photograph the tag or band, and record details (e.g., color, tagging program) in COMMENTS. Tag all dead marine mammals with a yellow marine mammal carcass tag supplied by FSB.

If the animal is alive, do not attempt to remove any tags or bands. Photograph the tag or band (if possible) and record details in COMMENTS.

Digital and Backup Cameras

Incidental takes can happen quickly, and if the animal is not brought onboard, you may only see it for a few moments. Always have your charged digital camera on you while on deck. You should also have a backup disposable film camera as part of your incidental take sampling kit. These may be used when there is a malfunction with the digital camera.

The On Deck Reference Guide lists what photographs are needed for each animal. If there are multiple animals, make sure you can distinguish them in the photo series. For example, you could write the PSID in your field notebook and take a picture of that page, to remind you later where each photo sequence began.

Minimum Sampling

It is important to follow the sampling requirements for each animal, as described in the FSB Observer On-Deck Reference Guide. All animals must have photographs, video (if possible), and descriptions of identifying characteristics, condition, tags, behavior, and release (if not retained); some animals have additional media requirements. Comments are required even if photographs are taken; cameras can be lost and digital files can be corrupted. Depending on the program, body measurements and tagging procedures may be required.

Comments that are needed for Incidental Takes

Record any additional information regarding the incidental take(s), especially when data are unable to be collected. The comments should include a list of identifying characteristics, details on the entanglement situation, and a description of the overall condition of the animal. Reference each comment with its corresponding field name and PSID. Also, include any other relevant information regarding the incidental take, such as for dredge/trawl gear if the animal was seen in the dredge/net prior to dumping on deck.

If an animal falls from the gear (alive or dead), record additional comments regarding the “fallout,” (e.g., the specifics of how the animal was entangled, whether the animal sank or floated away, etc.)

For marine mammals, comment on whether the animal was released with gear. Include a description of the gear (type, material, any buoys/floats, etc.), how the animal was entangled, and how much gear remained upon release. For sea turtles, comment on whether the animal slid out or escaped from the gear. Comment on if, and how, the turtle was hooked and/or entangled. If any gear was left on the animal when released, thoroughly describe the amount of gear, including linear feet. For seabirds, comment when animals are seen diving near setting/hauling of gear, if chasing bait, offal (entrails and internal organs of processed species), or fallouts near gear, or any details relative to how the animal(s) became entangled.

Comments that can help determine the animal condition include:

- How much of the animal was examined (*e.g.*, only dorsal and lateral sides seen).
- Descriptions of any new and/or healed wounds, including size, shape, texture, depth, and location; also if fresh blood is seen, or if unusual tissue marks are present.
- Descriptions of the amount and location of scavenger damage and/or decomposition, the firmness and coloration of tissues, condition of the skin (*e.g.*, cracked, sloughing, dull, glossy), the presence or absence of blood (record if bleeding), and any missing parts.
- Descriptions about the animal's behavior on deck and upon release (*e.g.*, lethargic, active, calm, vocalizing, struggling, swam away, sank, floated at surface, righted itself, dove, breathing patterns, etc.).
- Descriptions of the amount and location of gear remaining on the animal, and for sea turtles, the time required for resuscitation.

For **each marine mammal**, document how much of the animal was examined (*e.g.*, only dorsal and lateral sides observed). Thoroughly sketch and describe identifying characteristics, new and/or healed wounds, the amount and location of scavenger damage and/or decomposition, the firmness and coloration of tissues, condition of the skin (*e.g.*, cracked, sloughing, dull, glossy), the presence or absence of blood (record if bleeding), any missing parts, and smell. Include comments about the animal's behavior on deck and upon release (lethargic, active, calm, vocalizing, struggling, swam away, sank, floated at surface, righted itself, dove, etc.). Also record the amount and location of gear remaining on the animal. Reference each description with the animal's unique PSID#, and be sure to circle which side of the animal is illustrated. Record any additional information regarding the marine mammal incidental take(s), especially when data are unable to be collected. Reference each comment with its corresponding field name.

For **each sea turtle**, document how much of the animal was examined (*e.g.*, only dorsal and lateral sides seen). Thoroughly sketch and describe identifying characteristics (including scute counts), new and/or healed wounds, the amount and location of scavenger damage and/or decomposition, the coloration of tissues, condition of the skin (*i.e.*, cracked, cut), the presence or absence of blood (record if bleeding), any missing parts, and odor. Also, sketch the tag and biopsy location(s). Include comments about the animal's behavior on deck and upon release (lethargic, active, calm, struggling, swam away, sank, floated at surface, righted itself, dove, etc.). Provide details of animal's retrieval, and details of the release (lethargic, active, calm, struggling, swam away, sank, floated at surface, righted itself, dove, etc.). Also record the amount and location of gear remaining on the animal, and the time required for resuscitation. Record any additional information regarding the sea turtle incidental take(s), especially when data are unable to be collected. Reference each comment with its corresponding field name.

Additional sampling instructions

The following sections provide more detailed instructions for the sampling protocols described in the [FSB Observer On-Deck Reference Guide](#). Always follow the guide for the appropriate practices for each animal type and program.

Marine Mammals

Body Measurements

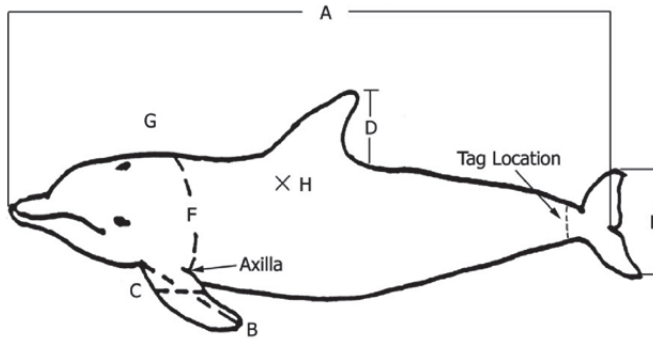

- A. Total Length - snout tip to fluke notch
- B. Flipper Length
- C. Flipper Width, maximum
- D. Height of Dorsal Fin
- E. Fluke Width, from tips of flukes
- F. Girth at Axilla (circumference)
- G. Blubber Thickness
- H. Body Temperature

Figure 50. Cetacean body measurements and sampling locations.

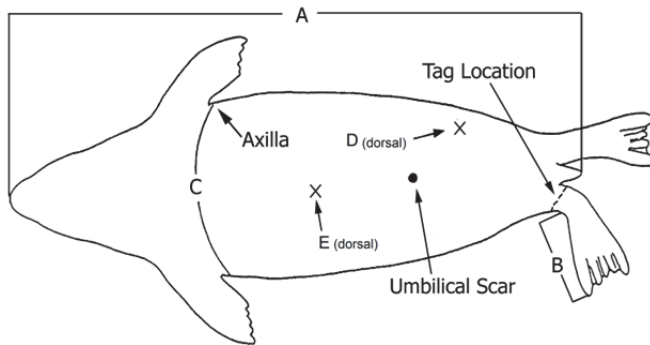

- A. Total Length - snout to tip of tail
- B. Rear Flipper Length
- C. Girth at Axilla (circumference)
- D. Blubber Thickness (ventral)
- E. Body Temperature (dorsal)

Figure 51. Pinniped body measurements and sampling locations.

Body

temperature: As soon as possible after the animal is brought onboard, and before cutting into the animal, take the **lateral dorsal musculature** temperature. To take a temperature, always insert the probe gently, and keep probe entry sites consistent.

Blubber thickness: On cetaceans, make an incision two to three inches behind the blow hole. On pinnipeds, make an incision in the dorsal surface just above the hip. Measure from where the blubber meets the muscle, up to and including the skin

Total length: Lay the tape measure on the ground parallel to the animal, not draped over it, to obtain a straight line measurement. Using a straight edge, create a perpendicular point from the tape on each end of the animal to obtain the measurement. On cetaceans, measure from the tip of the jaw (top or bottom, whichever is longer) to the fluke notch. On pinnipeds, measure from the snout to the tip of the tail.

Axillary girth: The girth is the circumference of animal at the axilla. On cetaceans, measure just under the pectoral flippers; on pinnipeds, measure just under the fore flippers. If the animal is too difficult to move (e.g., very large size), measure half the girth and record it as a comment. The preferred measurement is from the middle of the dorsal surface to the middle of the ventral surface.

Hind flipper or pectoral flipper length: On cetaceans, measure the longest length along one of the pectoral flippers, taken from the anterior (outside) edge of the flipper to the tip of the flipper. On pinnipeds, measure the length along one of the **rear** flippers, taken from the anterior (outside) edge at the joint where the flipper connects to the body to the tip of the flipper. The joint is best located by flexing the flipper forward and measuring from the point where the flipper flexes.

Additional Measurements for Cetaceans only

Pectoral flipper width: Measure the straight line width at the widest part of the same flipper on which the length was measured.

Dorsal fin height: Measure the straight line height of the dorsal fin from the posterior tip of the fin to the insertion at the body.

Fluke width: Measure the width of the flukes from one tip to the other. If only half of the fluke is present, measure it and record it as a comment.

Additional Measurements for Bottlenose Dolphins only

In addition to the body measurements required for all incidentally taken cetaceans, the following four measurements are to be taken for all bottlenose dolphins greater than 2 meters (approximately 7 feet) in total length: **snout to center of eye**, **snout to ear**, **snout to center of blowhole**, and **snout to flipper anterior insertion**. All measurements are **straight**, made parallel to longitudinal body axis.

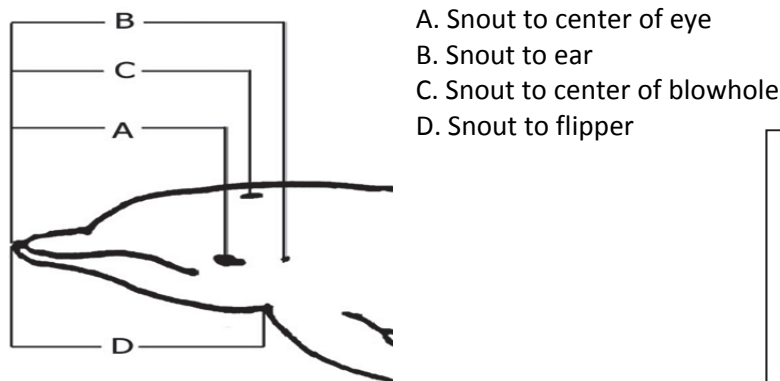

Figure 52. Additional measurements (straight line) for bottlenose dolphins.

Bottlenose dolphin identification

In our area, the inshore and offshore populations of bottlenose dolphins may overlap; therefore it is important that each bottlenose dolphin take be fully documented for proper identification. This includes the head measurements shown and photographs of both sides of the animal's dorsal fin.

Keep in mind that these additional measurements need to be taken before the head is removed. If time constraints necessitate choosing between taking the head or taking these additional measurements, take the head.

Biological Samples

Whenever possible, whole animal samples should be collected. This requires a great deal of communication with the captain, your provider, and FSB staff for storage and transport. If the whole animal cannot be retained, other biological samples can provide a lot of detail for scientists.

Head/Skull: Using a knife, remove the head/skull by cutting at base of skull where skull fuses with vertebrae. If the animal is badly decomposed, do not collect this sample.

Jaw/Teeth: Remove a lower half of the jaw for pinnipeds or ~4 teeth from cetaceans.

Whiskers: Remove the 3 longest whiskers from the lower part of the upper jaw (pinnipeds only).

Blubber: Remove approximately a 5cm x 5cm sample of blubber. If the animal is badly decomposed, do not collect this sample.

Fetus: If the fetus is aborted on deck, collect the whole fetus. Do not cut into the mother to remove a fetus.

Animal Condition - Marine Mammals

Dead, Fresh

- Normal appearance (as if the animal was still alive).
- Skin/fur cannot be easily pulled or separated from underlying tissue.
- Carcass not bloated with gas and/or when body punctured—no sound of gas escaping.
- Eyes, when present, may be clear, cloudy blue/white, or red.
- Lacking proximal odor
- Tongue and penis not bloated and/or protruding.
- May have white foam seeping from mouth/blowhole.
- Body, muscles, and blubber firm to the touch.
- May have fresh scavenger damage with tissue missing, but remaining muscle—firm, pink/red; blubber—firm, creamy white to pink; skin—firm with normal coloration; and organs still easily distinguishable.
- Muscle tissue appearance close to that of meat for human consumption.
- Blubber creamy white or pinkish coloration, no evidence of liquefying fat.
- Easily recognizable or identifiable to species.

Dead, Moderately Decomposed

- Does not appear as if it was “just alive” or “swimming”.
- Muscle tissues likely to be soft and poorly defined and pinkish white/gray in coloration.
- Carcass may be bloated with decomposition gases and/or likely to have gas escape or body cavity collapse if body cavity can be punctured.
- Organs/musculature mostly intact but different types may not be easily distinguishable.
- Carcass may be intact but collapsed due to internal tissue/organ deterioration.
- Tongue and/or penis may be bloated and protruding from orifices.
- Skin cracked and sloughing, may be easily separated from underlying body tissue.
- Tissues usually smell strongly of rotting flesh; distal odor evident.
- Hair may easily be separated from underlying tissue without tugging or stroking.
- May be fragile but can usually be moved mostly intact.
- Edges of wounds/tissue damage likely to be soft, mushy with grayish/whitish coloration.
- Recognizable by species (even though body parts may be missing).

Dead, Severely Decomposed

- Any remaining skin/hair is easily separated from underlying tissue.
- Tissues/organs exuding from body are dull in coloration with little visible distinction between tissue/organ type.
- Where skin/hair is gone, exposed blubber and other soft tissue is mushy and ill-defined.
- Carcass may be collapsed and deteriorating or partially intact.
- Muscle/blubber may be liquefied and/or falling off bones.
- Connective tissue holding bones together is soft and deteriorating.
- Muscle tissue usually uniform in coloration and texture with no distinct fibers visible.
- Unrecognizable to species or species group by typical coloration, patterns, or markings. Teeth may be used to identify species, if still intact.



Figure 53. Marine mammal in dead, fresh condition. Illustration is of a pregnant female.



Figure 54. Marine mammal in dead, moderately decomposed condition.

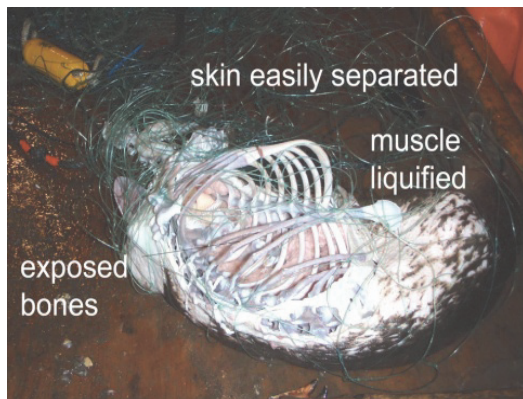

Figure 55. Marine mammal in dead, severely decomposed condition. Right: close up of head.

Sea Turtles

Body Measurements

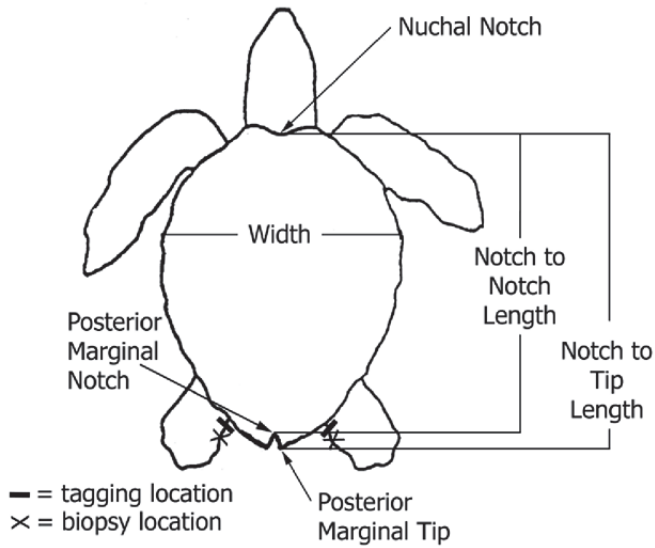

Figure 56. Sea turtle body measurements and sampling locations.

Notch to tip length: Measure the carapace from the center of the nuchal notch to the longest posterior tip.



Figure 57. Measuring turtle carapace length, notch to tip.

Notch to notch length: Measure the carapace from the center of the nuchal notch to the center of the two posterior tips.



Figure 58. Measuring turtle carapace length, notch to notch.

Carapace width: Measure the carapace across the widest part of the shell, perpendicular to the centerline of the carapace.



Figure 59. Measuring turtle carapace width.

Sea Turtle Identification Criteria

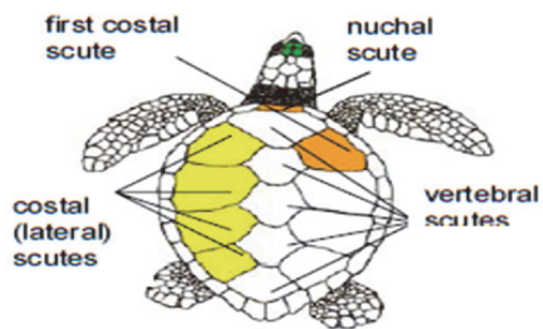

Figure 60. Sea turtle dorsal view, showing vertebral and costal (lateral) scutes.

Vertebral scutes: The plates that run down the middle of the carapace.

Lateral scutes: The plates that run on either side of the midline vertebral scutes.

Inframarginal scutes: A series of small scutes covering the bridge bones, between the carapacial marginal and the sides of the adjacent plastral scutes.



Figure 61. Sea turtle ventral view, showing inframarginal scutes.

Pre-frontal scales: The scales between the eyes of the turtle. There should be either one or two pairs.

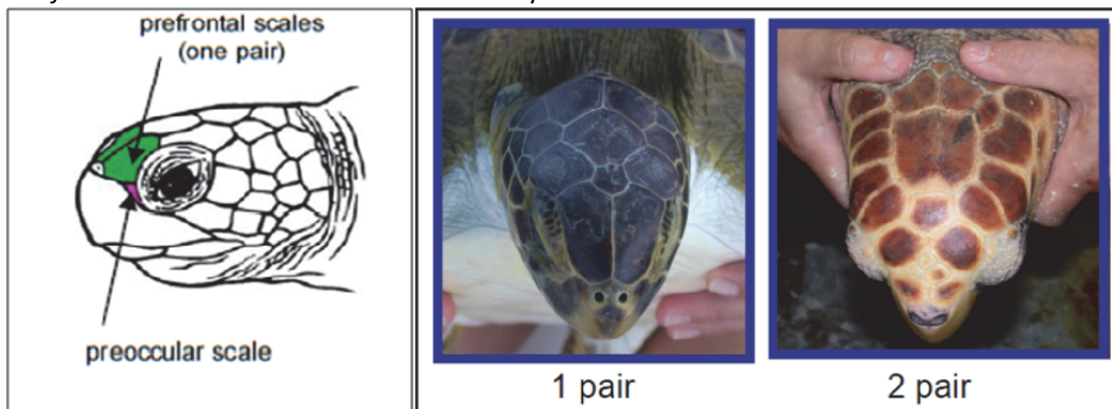

Figure 62. Head of sea turtles, showing pre-frontal scales.

Sea Turtle Safe Handling

Wear gloves, and clean and disinfect any cuts or abrasions incurred when handling sea turtles. Sea turtles have powerful jaws. Always keep clear of the head and wear durable footwear when working around them on deck. Sea turtles of all species, except leatherbacks, have claws on their flippers. Keep clear of flapping flippers, especially if the animal is on its back (carapace). Avoid straddling animals when you are working with them. Never pick up sea turtles by the flippers, head, or tail. For all turtles, except leatherbacks, pick them up by placing one hand at the front and back of the carapace or one hand at each side of the carapace. Extra care should be taken when handling leatherback turtles since they are covered with skin. Leatherback turtles should never be turned over on their carapace and should always be picked up by their plastron, e.g., by supporting their underneath instead of just picking up by their carapace. Since leatherback turtles can be large, you might need assistance when moving them - do not try to drag or push them. Placing a clean, damp cloth over an agitated turtle's head/eyes can sometimes have a calming effect. Be careful not to cover the nares (nasal openings) and possibly suffocate the animal. Turtles brought on deck should be protected from adverse weather conditions as much as possible. If it is sunny and hot, turtles should be covered with a clean

damp cloth/towel and kept in the shade. If it is cold, turtles should be insulated with available clean dry material and kept out of the weather.

Sea Turtle Biological Sampling

Genetic Sampling Protocols

Genetic samples provide valuable information on stock structure. Small skin biopsies provide a simple method to obtain tissue samples for genetic studies from live and dead sea turtles. For live or comatose turtles larger than 25 cm notch to tip carapace length, and all dead turtles, tissue samples large enough for genetic analysis can be obtained using a disposable biopsy punch.

This tool consists of a plastic handle that supports a sharp circular blade. Tissue samples should be preserved in 5 ml vials filled with saturated saltwater. The use of latex gloves is required throughout the sampling procedure.

1. The best method is to leave the turtle carapace up, with a damp cloth over the head (careful not to cover nares).
2. Put on a pair of latex gloves, and thoroughly wipe the ventral and dorsal surfaces of the rear flipper with a Betadine wipe. This area is along the trailing edge of the flipper and is just past (away from the body) the Inconel tag location, which is near the first scale closest to the body. The betadine must remain on a minimum of 5 minutes.
3. Use an alcohol swab to wipe the hard surface (plastic dive slate, biopsy vial cap, or other available clean surface) that will be used under the flipper. Allow alcohol to evaporate, and then place this surface underneath the Betadine treated flipper.
4. Holding a new biopsy punch by the thumb and index finger, press the biopsy punch firmly into the flesh. Make sure the biopsy punch goes past the flipper edge, creating a 3/4 crescent shaped biopsy. Rotate the punch one or two complete turns. This technique promotes quicker healing. The biopsy tool has a sharp cutting edge, so exercise caution at all times. Wipe the punched area with a Betadine swab.
5. Repeat the procedure to the other rear flipper using the same biopsy punch. You will now have two samples from this turtle in the same biopsy punch.
6. Place the plugs directly into a vial containing saturated saltwater. Remove the tissue plugs by using a pair of tweezers cleaned with alcohol wipes, a clean toothpick, or by tapping the punch on the edge of the vial. It is important that the tissue samples do not come into contact with any other surface or materials during collection.
7. Secure the vial cap. Using a fine point permanent marker (Sharpie), label the vial with the same PSID number used on your Sea Turtle Biological Sample Log and the trip number. Then cover the writing with a piece of clear tape to prevent smearing. After capping, tightly wrap a piece of Parafilm around the vial cap and place it in a Whirl-pak. Include a completed tyvek tag with all relevant information, except for disposition code.
8. Be sure to indicate that biopsy samples were taken on the Sea Turtle Biological Sample Log.
9. Dispose of the used biopsy punch. It is very important to use a new punch for each animal to avoid cross contamination.

10. Submit the vial with your data. It can be mailed in with your paper trip.
11. Maintain all biopsy equipment in a clean and dry condition in the biopsy sample kit. Ensure that the kit has all necessary supplies. Notify the Area Coordinator or FSB Incidental Take Lead for additional supplies. Air dry all equipment once you land from trip.

Tagging Sea Turtles with Inconel Tags

Live or Comatose Sea Turtles:

1. All turtles should be examined for existing external tags, prior to applying new Inconel tags. All existing tags should be recorded accurately. Inconel and other external tags are recorded on the Marine Mammal, Sea Turtle, and Seabird Incidental Take Log. Prior to release, each turtle **larger than 26 cm Notch to Tip carapace length** should have two well attached and clearly legible external Inconel tags, one on each rear flipper.
2. The best method is to leave the turtle carapace up, with a damp cloth over the head (careful not to cover nares).
3. Put on a pair of latex gloves and thoroughly wipe the ventral and dorsal surfaces of the rear flipper with a Betadine wipe. This area is along the trailing edge of the flipper on the first scale closest to the body. The betadine must remain on a minimum of 5 minutes. Record the tag identification number prior to placing it into the applicator. Place the pointed (piercing) side of the tag up and place the end of your index finger inside the tag against the bend. Pull the tag straight back into the open jaws of the applicator, aligning the pointed side of the tag opposite to the side of the pliers that has the small depression (see Figure 63). Do not squeeze the pliers before you are ready to tag, or the tag will fall out.
4. Position the Inconel tag so that it extends slightly past the trailing edge of the rear flipper (approximately 1/3 the length of the tag). For leatherback turtles, tag 5cm from base of tail. For all other turtles, tag in the soft tissue between body and the first scale. It should not be cinched in too tight against the flipper without room to move freely. Also avoid positioning the tag close to edge of the flipper where it can rip out. See Figure 64.
5. Due to tag loss, double tagging is standard procedure. If the recommended tagging site is damaged, or is for some reason unsuitable for tag application, then an alternative site along the trailing edge of the front flipper may be used.
6. There are two distinct motions involved in applying Inconel tags. The first step is to squeeze the applicator so the tag point pierces the flipper. The second step, a moment later, involves applying greater force to drive the point through the tag hole, and make it bend over completely. Use both hands and squeeze in a firm, steady manner to ensure that the tag will fully lock. The handles of the applicator should always be gripped as far back as possible to gain maximum leverage. The tag point should pierce the flipper and lock into place with the tip bending securely over by 3-5 mm. After attachment, feel the tag with your finger and visually inspect to make sure the point has bent over into a fully locked position. Repeat the procedure, and apply a second tag on the other rear flipper. All live turtles should be double tagged in this manner. If possible, use consecutive tag numbers on the same turtle.
7. In the event that the Inconel tag does not lock, fit the pliers back around the tag and apply greater pressure. Tags that fail to lock when applied to a turtle are difficult, frustrating, and sometimes impossible to properly correct, even when using additional tools. Improperly applied tags can be shed quickly. A tag that malfunctions should be removed, recorded as being destroyed, and replaced with a new tag. If you are having persistent problems when attempting to apply Inconel tags, please contact the FSB staff for help or additional training.

8. When you have finished working with one turtle, clean and disinfect the applicator (pliers) to avoid cross contamination between turtles. Maintain the tag applicators so they continue to work properly by washing them in fresh water after use, drying them thoroughly, spraying the spring and pivot surface with WD40, and storing them in a sealed plastic bag once dried.
9. In order to ensure that Inconel tags remain clean and sterile, keep them in that bag, and remove them one at a time as needed. Inconel tags are expensive; take care of them, and do not pass them on to other observers. Any lost tags should be reported to FSB personnel.



Figure 63. Sea turtle Inconel tag applicator.



Figure 64. Properly applied Inconel tags to the rear flippers of a live sea turtle.

All Dead Sea Turtles:

Tag all dead sea turtles with a single Inconel tag following the above guidelines, and take a biopsy from all dead sea turtles following the protocols previously described for live or comatose sea turtles. Any animals that cannot be brought ashore whole will be released at sea following the same release guidelines followed for live or comatose turtles. You are requested to retain all dead sea turtles if possible. Whole sea turtle carcasses can provide important information about the health of the animal at the time of death. Fresh dead turtles observed being taken during fishing activities provide a rare necropsy opportunity for trained professionals. On single day trips, you should request that all dead sea turtles be brought back to the dock. On multi-day trips, you should request space in the fish hold so that dead turtles can be brought back to the dock. It may

not be possible to accommodate larger turtles. Using the heaviest bags available, double bag salvaged turtles, and take all appropriate measures to absolutely ensure that fish are not contaminated or spoiled by contact with the turtle. Fill out two Tyvek tags, using a permanent marker (Sharpie). Fill in all fields, except for the disposition code. Attach one Tyvek tag directly to the flipper of the dead sea turtle and a second to the outside of the bag. Before you return to the dock, contact your Program Manager or Area Coordinator to notify them that you have a dead sea turtle. Contact FSB staff at (508) 566-6071 if there are any specific sampling questions.

PIT Tag Scanning Guidelines

All turtles should be scanned for PIT tags. Many turtle research projects now routinely use PIT tags in addition to external tags.



Figure 65. Scanning sea turtle for PIT tags.

1. Keep your PIT tag scanner inside a plastic zip lock bag whenever you use it. PIT tag scanners are expensive, and since they are not waterproof, this will help protect them from water or slime. Even the smallest amount of water will destroy a PIT tag scanner, so please be careful when using and/or storing the scanner. Placing the scanner in a plastic bag during use will not affect its performance. However, do not store the scanner in a plastic bag, since condensation may develop inside the plastic bag.
2. Scan the provided sample PIT tag, attached to the scanner, to verify that the batteries are good and that the PIT tag scanner is working properly. Be sure to hold/keep the sample tag well out of the way when you are scanning a sea turtle. Test the scanner periodically. Avoid situations where you are unable to properly scan turtles because of dead batteries.
3. Place the PIT tag reader scanning surface directly on the skin of the turtle and **SLOWLY** scan the dorsal (top) surface of both front flippers, including the "shoulder," "armpit," and neck areas. For the scanner to work properly, you will need to hold the button down while scanning. It is important to move the reader slowly, since it cycles through different tag types and frequencies. An overlapping circular motion has been shown to increase tag detection over a straight swiping motion. Scan the entire area multiple times to ensure that you have not missed a tag. Repeat the same procedure for both rear flippers. See Figure 65.
4. For all turtles, EXCEPT leatherbacks, gently place the turtle on its carapace and scan the ventral (bottom) surface of all flippers, following the procedures outlined above. Also check the area of plastron, between the front and rear flippers.

5. If a PIT tag is detected, record the identification code, exactly as it appears on the PIT tag scanner display. Codes may be all numbers or alpha-numeric. Record all hyphens, which may appear as part of the code. Double check to make sure you have recorded the code exactly as it appears on the scanner display.
6. Retain the turtle and notify the FSB Incidental Take Lead if a tag is detected. We will be able to learn more about the history of the PIT tag. If the turtle is dead, make all attempts to retain it, since additional information may be obtained from the PIT tagged turtle.

Handling and Resuscitation Requirements

Any live sea turtle taken incidentally taken during the course of commercial fishing or scientific research activities must be handled with care to prevent injury. Incidentally taken sea turtles should be observed for activity, and then returned to the water according to the following procedures: Resuscitation must be attempted on sea turtles that are comatose or inactive, but not dead, by placing the turtle right side up (on plastron) and elevating the hindquarter 20° for a period of 4 to 24 hours (refer to Figure 66). Periodically rock the turtle from side to side by holding the outer edge of the carapace and lifting one side about 3 inches, alternate lifting from one side to the other. This allows the lungs to drain off water. Sea turtles being resuscitated must be protected from the elements at all times. If it is sunny and warm, then shade the turtle and keep it moist by using clean sea water or clean damp towels. If it is cold, then keep the turtle out of the weather and warm by insulating with clean rags or other suitable material.

Important: Do not assume that an inactive turtle is dead. The onset of rigor mortis, or the rotting of flesh, is often the only definitive indication that a turtle is dead. Otherwise, the turtle is determined to be comatose or inactive and resuscitation attempts are necessary.

There are five methods that may elicit a reflex response from an inactive animal:

Cloaca or tail reflex: Stimulate the tail with a light touch. This may cause a retraction or side movement of the tail.

Eye reflex: Lightly touch the upper eyelid. This may cause an inward pulling of the eyes, flinching, or blinking response.

Nose reflex: Press the soft tissue around the nose, which may cause a retraction of the head or neck region, or an eye reflex response.

Tail/flipper pinch: Pinch the tail or flippers, which may cause a retraction response.

Splash small amount of water on face: This may cause a retraction of the head or neck region, or an eye reflex response.

Sea turtles that are alive or dead (if not retained) must be released over the stern of the vessel. In addition, they must be released only when fishing gear is not in use, when the engine gears are in neutral position, and in areas where they are unlikely to be recaptured or injured by fishing gear or vessels. ALL animals should be released as close to the water surface as possible.

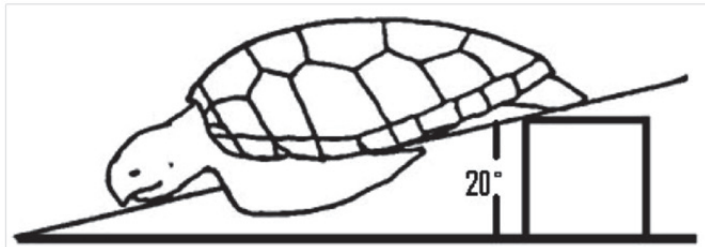

Figure 66. Proper positioning of sea turtle for resuscitation.

Transfer of Injured Sea Turtles for Rehabilitation

Turtles can sustain a variety of life threatening injuries when they interact with fishing gear. Beyond resuscitation, you are not trained or expected to administer medical aid. When injured animals are released, it is likely that a number of them die. With treatment and rehabilitation by trained professionals, these animals have a higher probability to survive, and be released back into the wild. When possible, you are requested to transfer live, injured turtles to a cooperating U.S. Coast Guard vessel, or to deliver them to a NMFS permitted member of the Sea Turtle Stranding and Salvage Network (STSSN) in the state where the vessel lands. This can be found in the on-deck reference sheets. On single day trips, all injured turtles should be brought in whenever possible. On multi-day trips, arrangements should only be made to bring in injured turtles, if the observed fishing vessel will land within a 36 hour period. If the observed vessel will not be landing within the 36 hour period, contact FSB staff at (508) 566-6071 to make arrangements for a U.S. Coast Guard at sea pick up. Keep in mind that these plans should be discussed with the captain first.

A plan for the exchange of an injured turtle needs to be established before making the decision to bring an injured turtle in to the dock. You may need to request the use of the vessel's satellite phone or radio to contact FSB staff or the STSSN. Vessels will be reimbursed for all incurred costs. Turtles should not be brought in for rehabilitation unless the STSSN can meet you at the dock when the vessel lands. It is not your responsibility to deliver the turtle to a rehabilitation facility. If you are unable to establish contact with the STSSN, then the animal should be released. Contact FSB staff at (508) 566-6071 before releasing, as FSB staff may be able to help you contact the STSSN. It is understood that any request to transfer or bring in a turtle is contingent on the cooperation of the vessel operator. You are advised to make a polite request of the vessel operator, and to be aware that a number of factors may prevent the vessel operator's cooperation. In that case, the turtle should be released following the above release guidelines. The behavior of the released turtle must be noted.

Animal Condition - Sea Turtles

Dead, Fresh

- Normal appearance (as if the animal was still alive) but has not responded to stimulus tests for more than 24 hours and/or rigor mortis has set in.
- Skin cannot easily be pulled or separated from underlying tissue.
- Carcass not bloated with gas and/or when body punctured—no sound of gas escaping.
- Eyes—when present may be clear, cloudy blue/white, or red.
- If hardshelled, scutes are not flaking or disintegrating.
- May have fresh scavenger damage with tissue missing, but remaining muscle—firm, pink/red; blubber—firm; skin—firm
- Muscles and blubber firm. with normal coloration; and organs still easily distinguishable.
- Muscle tissue pink or red in coloration.
- Easily recognizable or identifiable to species.
- Blubber creamy with no evidence of liquefying fat.

Dead, Moderately Decomposed

- Does not appear as if it was “just alive” or “swimming”.
- Muscle tissues likely to be soft and poorly defined and pinkish white/grey in coloration.
- Carcass possibly bloated with decomposition gases.
- Organs/musculature mostly intact but different types may not be easily distinguishable.
- If body cavity punctured—likely to have gas escaping or body cavity collapses.
- Carcass may be intact but collapsed due to internal tissue/organ deterioration.
- Tissue may be bloated and protruding from cracks/openings in the shell.
- Tissues usually smell strongly of rotting flesh.
- Scutes may be sloughing, may be easily separated from underlying body tissue.
- May be fragile but can usually be moved mostly intact.
- Edges of wounds/tissue damage likely to be soft, or mushy with greyish/whitish coloration.
- Recognizable by species (even though body parts may be missing).

Dead, Severely Decomposed

- Any remaining scutes and/or skin are easily separated from underlying tissue.
- Tissues/organs exuding from body are dull in coloration with little visible distinction between tissue/organ types.
- Where scutes and/or skin is gone, exposed blubber and other soft tissue is mushy and ill-defined.
- Carcass may be collapsed and deteriorating or partially intact.
- Muscle/blubber may be liquefied and/or falling off bones.
- Connective tissue holding bones together is soft and deteriorating.
- Muscle tissue usually uniform in coloration and texture with no distinct fibers visible.
- Unrecognizable to species or species group by typical coloration, patterns, or markings.

Seabirds

Handling live seabirds

Occasionally, you may encounter situations where seabirds interact with fishing gear as it is being hauled and entangled birds come aboard alive. This occurs most often in fisheries targeting herring, mackerel, and squid. If it is safe to be on deck and you are comfortable doing so, assisting the crew with disentangling birds in a gentle manner is appropriate and can significantly increase a seabird's chance of survival. Additionally, assessing a live bird's condition before release and allowing stunned birds the benefit of a brief recovery period will also contribute to their survival. In general, birds are sensitive to handling and their bones can be easily broken, yet larger birds, particularly Northern Gannets, can inflict injury with powerful bills. If handled with care and caution risk of injury to both birds and observers can be avoided. The following guidelines should be followed if time and captain permits.

When removing a bird from the gear, preferably lift it with a net (longline) to bring it onboard. Avoid pulling the bird up with line tension. Support the body of the bird while disentangling. Extract the bird from the gear as gently as possible, avoiding tugging on the neck or wings. Evaluate whether the bird is releasable (active and alert) or may benefit from a brief rest on deck, if space is available.

To restrain a bird, wrap its head in a towel and cover its eyes to keep it calm. Hold the back of the head, avoiding the soft neck, and don't cover the nostrils. Be aware that birds may vomit when stressed; if regurgitating, briefly release the bill or the bird may suffocate. Carefully fold the wings. If necessary, hold the bird firmly but do not squeeze the chest area.

If the bird is water logged and exhausted, let it rest in a quiet, dry area, such as a crate or box with holes, for an hour or two on a quiet part of the deck. Do not feed the animal. Check it every half hour. If the bird is dry, holds head erect, and stands with wings in a normal folded position, it is ready for release.

To release a bird, ask the captain to slow the vessel. Slowly lower the bird by hand to the water. **Do not** toss birds into the air.

Animal Condition - Seabirds

Dead, Fresh

- Feather, skin of legs, feet & bill coloration close to or same as that of live bird.
- May have fresh scavenger damage with tissue missing, but remaining muscle—firm, pink/red; blubber—firm; skin—firm with normal coloration; and organs still easily distinguishable.
- Feathers resist being separated from skin.
- Exposed muscle tissue firm and pink/red coloration.
- Eyes may be plump or dessicated/sunken.
- Skin on feet/legs firm and not separated easily from bone.
- Easily recognizable or identifiable to species.

Dead, Moderately Decomposed

- Feathers easily separated from body tissue.
- Feathers usually waterlogged.
- Usually faded/discolored facial tissue, feet, legs, and beak.
- Body organs/tissue smells like rotting flesh.
- Muscle tissue usually soft to mushy and poorly defined, with light pink to grey coloration.
- Recognizable by species (even though body parts may be missing).

Dead, Severely Decomposed

- Beak may be separating from the head/body.
- Remaining tissue is usually sparse and is very mushy or liquefied.
- Feathers easily falling/or pulled out of skin.
- Tissue falling off bones and skeleton disarticulating due to disintegration of connective tissue.
- Skin on feet/legs falling off bones.
- Unrecognizable to species.
- Skin separated from other body tissues and mushy; tears easily.

Sightings of Protected Species

Often you will see marine mammals and sea turtles near the vessel but not coming in contact with the gear. In the NEFOP and IFS programs, these are recorded as sightings, rather than incidental takes. Sighting data is used to determine temporal and spatial distribution of protected species, and the relative abundance and behavior of animals in the vicinity of fishing operations. Seabird observations are not considered sightings.

In some fisheries and programs, such as the limited gillnet sampling protocols, you will be conducting dedicated protected species watches (see Limited fish sampling). These provide information related to the frequency of occurrence relative to the time spent actively watching for sightings. In contrast, opportunistic sightings may happen at any time and in any fishery. These can occur while the gear is being fished, while the crew is processing catch, or even during transit in or out of harbors. Sightings may not be associated with a particular haul, so you must record the time, location, and conditions for each event.

Comments must be provided that include all field characteristics you were able to actually see and use to make an identification of the animal. If the animal is far from the vessel, you may have difficulty observing all criteria needed for an exact identification. Take as many pictures as possible for the best chance of capturing the animal.

Any unusual marks, scars, or coloration on the animal should be noted. If possible, attempt to estimate the size of the animal. If there are multiple animals that cannot be counted accurately, include a range estimate, and a separate count of any calves. Include comments on the behavior of the animal, such as swimming speed and direction, and any other activities noted while the animal was observed.

Notes

Catch Estimation

Collecting accurate weights is extremely important. It will be possible to obtain actual weights in many situations. In some cases (*e.g.*, extremely large catches, rough weather, limited time and/or space), it may be necessary to estimate the catch or a portion of the catch. Estimated weights more than 1 pound are always rounded to a whole pound for reporting; actual weights or weights less than 1 pound may be rounded to the nearest tenth of a pound.

Each species and disposition encountered on a haul must have a corresponding weight. If you see a species but do not have an opportunity to weigh it, you must provide an estimated weight using one of the methods listed below.

Estimation Methods

Actual Weights

An actual weight is a weight taken using a measuring scale provided by FSB or an observer provider. All individuals of a species and disposition must be actually weighed to be recorded as an actual weight. It is important that scales are well-maintained and zeroed before being used. There are currently two types of approved scales:

Spring Scales: A handheld scale that measures the tension on a coiled spring. Issued in both small (maximum weight of 10-12lbs) and large (maximum weight of about 100lbs).

Electronic Scales: A scale with electronic weight readout. FSB currently uses Marel digital motion-compensating marine scales (see Marel Scales). Issued in both small (maximum weight of 60lbs) and large (maximum weight of 150lbs) versions.

Tally Counts

In some situations, catch may be coming onboard too quickly, or in such quantities, that actual weights are not possible. To take a tally count, obtain actual weights of a representative sample (approximately 20%) of a particular species and disposition, in order to determine an average weight per individual. This average is multiplied by the actual count of individuals to estimate the total weight of that species and disposition in the haul. Be sure to obtain your sample from the beginning, middle, and end of the haul, to stay representative of the catch.

Example

The crew is tossing spiny dogfish overboard quickly. The captain says he does not want to keep any of them. You weigh 30 animals with a total weight of 172 pounds, and count a total of 247 animals.

Average weight per animal = $172\text{lbs} \div 30 \text{ animals} = 5.73\text{lbs}$, rounded to 5.7lbs per animal

Total estimated weight = $5.7\text{lbs/animal} \times 247 \text{ animals} = 1407.9\text{lbs}$, rounded to 1408lbs

Remember to keep an accurate count by species and disposition. It may be necessary to account for size differences between sexes (e.g., male vs pregnant female spiny dogfish). In these cases, obtain a separate average weight for each grouping, and later combine into a total weight for the species and disposition.

Basket/Tote Counts

Basket/tote counts are similar to tally, in that an average weight is multiplied by an actual count of something. To take a basket or tote count, first ensure that the containers all contain one species with the same disposition. Obtain an average weight of at least 20% of the containers. This average weight can then be multiplied by the number of baskets or totes that were filled with that species/disposition. Be sure to account for the weight of the containers by taring your scale or subtracting the weight of an empty container. The average weight should always be rounded to the nearest tenth of a pound. Only count full containers; do not estimate portions of a container (e.g., one half basket). The weight of partial containers can be added to the weight calculated of full containers for a total estimated weight. Adding actual weights of partial containers is expected when using this method, and do not constitute a combination method.

Example

The crew fills 42 full flush baskets with kept redfish. The last basket is only partially full and weighs 37 pounds (actual weight). You weigh 8 full baskets.

Individual basket weights = 66, 65, 64, 67, 66, 67, 67, and 68lbs

Average weight per basket = 66.25lbs, rounded to 66.3lbs

Estimated weight = 66.3lbs x 42 baskets = 2784.6lbs, rounded to 2785lbs

Total weight = 2785lbs (full baskets) + 37lbs (partial basket) = 2822lbs

Captain's Estimates

Captain's estimates are provided by the vessel captain when you are unable to weigh or estimate a species or portion of the catch. Captain's estimates may be used for unobserved hauls, or for catch that cannot be weighed (e.g., very large rocks). This method can also be used if the catch is being immediately put into the fish hold and you cannot access it.

In some cases, the captain may provide an estimated number of baskets, or an estimated weight per basket. Document which portion of the estimate was provided by the captain and which was actually weighed/counted. You can also ask the captain for an estimate to use as a comparison to your own estimates. If there are large discrepancies, document the situation in comments.

Visual Estimates

Visual estimates are made without weighing, counting, or subsampling. Visual estimates may be based on observer experience, but should not be used unless there is no other way of estimating the weight. Visual estimates may be used for trash and debris that comes up in the gear. If possible, record an estimate of the number of individuals or volume observed (e.g., "3 lobsters thrown over before I could weigh them; approximately 3lbs each" or "About 1 tote's worth of skates washed out scuppers").

Subsampling Methods

Several subsample extrapolation methods are available when preferred estimation methods (e.g., actual weights or tally/basket/tote counts) are no longer attainable. Extrapolation involves applying a known subsample to an unknown total, with the assumption that the subsample is representative of the total. A unit-less multiplier is calculated by dividing the total amount by the subsample amount; each weight in the subsample can then be extrapolated using the multiplier. The resulting estimate is dependent on many factors, such as:

- How accurate the total and subsample units are,
- The proportion of the total that was subsampled, and
- How representative the subsample is of the whole, which in turn is dependent on the relative composition of the species within the catch.

Almost any units can be used, as long as the units for the total and subsample are the same. For all subsampling, a target of at least 20% (i.e., one fifth of the total catch) has been determined to give the best accuracy when sampling catches typically seen on NEFSC observed trips.

Count-to-Count and Weight-to-Weight

As their names imply, the Count-to-Count and Weight-to-Weight methods use a ratio of individual animals or pounds, respectively. To determine the multiplier, divide the total by the subsample, making sure that the units are the same. To extrapolate the subsample weights, multiply the weight of each species/disposition in the subsample by the multiplier.

Example of Count-to-Count

The crew is discarding a large amount of mixed skates. You cannot separate and weigh each species individually, but you tally count a total of 93 individuals, and collect a random subsample of 20 individuals, which you sort and weigh by species.

Multiplier = 93 individuals (total) ÷ 20 individuals (subsample) = 4.65
 Winter skate: 85lbs (subsample) x 4.65 = 395.25lbs, rounded to 396lbs
 Little skate: 78lbs (subsample) x 4.65 = 362.7lbs, rounded to 363lbs
 Unidentifiable small skates: 4lbs (subsample) x 4.65 = 18.6lbs, rounded to 19lbs

Example of Weight-to-Weight

The crew is keeping a large amount of mixed conch species. You cannot separate and weigh each species individually, but you can obtain a total weight of 125 pounds, and a random subsample of 19.3 pounds, which you sort and weigh by species.

Multiplier = 125lbs (total) ÷ 19.3lbs (subsample) = 6.47
 Channeled Whelk: 15.4lbs (subsample) x 6.47 = 99.64lbs, rounded to 100lbs
 Knobbed Whelk: 2.8lbs (subsample) x 6.47 = 18.12lbs, rounded to 18lbs
 Lightning Whelk: 1.1lbs (subsample) x 6.47 = 7.12lbs, rounded to 7lbs

Volume-to-Volume

Volume-to-Volume is used when factors such as time and space become limited on deck. This usually occurs with very large volumes of mixed catch that are being processed quickly by the crew. Volume-to-Volume may be used on all catch on a particular haul, or only on a portion of the catch (e.g., only for discards, only for certain species).

The Volume-to-Volume method uses subsamples taken in containers with known volumes, such as orange bushel baskets (1.47ft³) and black fish totes (2.65ft³). The total volume can be determined by filling standard containers, as long as you can obtain an accurate count of the total.

Example

The crew fills 15 totes with mixed skate species. You sample 3 totes, and weigh each species.

Sample Weight Multiplier = 15 totes ÷ 3 totes = 5.00

Subsample:

Winter Skate (kept) = 157lbs x 5.00 = 785lbs total

Little Skate (kept) = 109lbs x 5.00 = 545lbs total

If the catch is too large to shovel into baskets, you will have to measure the dimensions of the catch (length, width, depths, etc.) and apply standard geometric formulas to calculate the volume. This involves more math than other methods; the following steps have been devised to help you through the process.

Step 1: Be organized and prepared

There are many factors to keep in mind when using Volume-to-Volume. Organization and familiarity with your sampling tools will help you succeed when using this method. Communication with the captain and crew will be essential. You will need to convey your duties and needs to them, in order to ensure getting access to the catch pile before it is altered in any way (e.g., before they flood the checker pen, before the scuppers are opened, before they start sorting the catch). You should also communicate with them about where the best sampling location will be for you, and if you will have access to extra baskets, totes, or checker pens on deck. You should also communicate with the captain about how they process the catch on deck, and where they typically dump the catch (if there are multiple checker pens present).

Once you have worked out a game plan with the fishermen, and before the catch is dumped on deck, you should take time to measure all available checker pen shapes, in order to prepare yourself for using Volume-to-Volume effectively. You should determine the checker pen shapes that are present, and collect all possible area measurements. It is best to collect as many dimensions as possible, in case they remove checker boards during the trip, and alter the shape of the pen (see Figure 67).



Figure 67. An example of multiple checker pen shapes present on deck. Note the ropes attached to each board, which allow the fishermen to manipulate the size and shape of the checker pen, as needed.

You should record all measurements in your notebook, so you will be able to reference it as needed.

Break down irregularly-shaped areas into smaller areas (e.g., rectangles and trapezoids) for measuring and calculating (see Figure 68).

Rectangle: The lengths along the top and bottom of the checker pen or fish bins are equal, and the widths along the sides are equal.

Trapezoid: Two sides of the checker pen or fish bin are parallel, but unequal, in length; the other two sides may be straight or angled, and may or may not be equal in length.

Triangle: The checker pen or fish bin has three sides. This shape is typically seen in combination with other shapes.

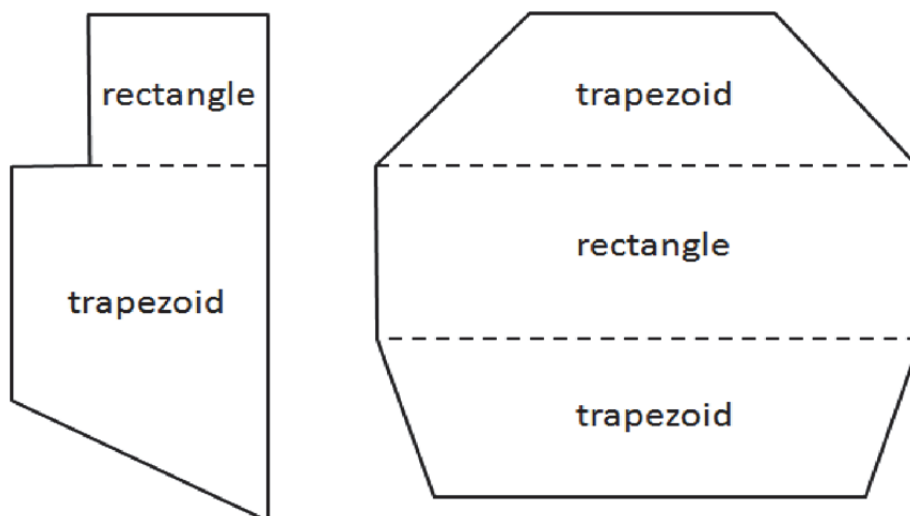

Figure 68. An example of how to break down irregularly-shaped areas into smaller areas for measuring and calculating.

You should also collect potential depth measurements (e.g., halfway to the top of the checker pen, up to the top of the checker pen, up to the top of a scupper) and apply them to your area measurements, in order to determine a range of potential catch volumes. You can refer to the following table to determine how many baskets and/or totes you will need to collect for a representative subsample, once the catch is onboard.

Table 1. Guidelines for determining how many baskets and/or totes you will need to obtain for an appropriate subsample.

Approximate Size	Est. Catch Volume	# Baskets OR # Totes needed for 10-20% subsample	
5' x 5' x 1' or 5' x 10' x 0.5'	25ft ³	2 - 3	1 - 2
5' x 5' x 2' or 5' x 10' x 1'	50ft ³	3 - 7	2 - 4
5' x 10' x 1.5' or 10' x 10' x 0.8'	75ft ³	5 - 10	3 - 6
5' x 10' x 2' or 10' x 10' x 1'	100ft ³	7 - 14	4 - 8
5' x 10' x 2.5' or 10' x 10' x 1.3'	125ft ³	9 - 17	5 - 9
10' x 10' x 1.5' or 10' x 15' x 1'	150ft ³	10 - 20	6 - 11

Reminder: Examples are rounded for simplicity. Always use actual measurements in your calculations.

Example

On the steam out, you measure a checker pen dimensions as 5.6ft x 11.2ft. As a marker, you note that the top of the first checkerboard is 0.8ft high.

To prepare yourself before catch is dumped, you look in the table to find the nearest approximate size (5' x 10' x 1') and note that a 20% subsample for that size is 7 baskets or 4 totes.

Once catch is dumped, you can adjust by taking more or fewer baskets, depending on whether the catch is above or below the checkerboard you originally measured.

Step 2: Measure the pile

After the catch has been dumped on deck, you will need to assess the catch pile shape. If it is dumped in a checker pen, you can use the same area measurements that you already obtained. However, you will need to ensure that nothing has been altered since you took your measurements, and that the catch pile occupies the entire pen shape. If not, you will need to obtain new area measurements, to prevent over-extrapolating the volume calculation.

Be careful when obtaining measurements for trapezoids. Ensure that the length measurement is perpendicular to the width measurements (rather than a diagonal measurement).

If the catch is dumped on deck, rather than in a checker pen, it will typically fall into an oval or half-oval shaped pile. You may be able to adjust the shape of the pile by shoveling or kicking it into more defined areas.

Oval: The catch is dumped on deck in an irregular pile with roughly rounded edges. The edges are not bounded by the deck or other vertical surface.

Half-Oval: The catch is dumped on deck against the side of the vessel (or another vertical surface). The edge that is not against the vessel has roughly rounded edges.

Next, you will obtain depth measurements from throughout the catch pile, in order to calculate an average depth. You should utilize your depth stick when possible, as it will allow you to reach to the bottom of the catch pile, and obtain more accurate depth readings. Be sensitive as to how you are operating the depth stick within the catch pile. Try to avoid forcefully moving the stick through the catch, potentially damaging the quality of the fishermen's product.

If the catch pile is not bounded by all sides (e.g., not dumped within a checker pen), then you will need to include a depth of 0 feet as one of your 10 measurements. Avoid targeting especially high or low points within the catch pile. Be representative, without biasing the data. It may help to visually separate the pile into a grid, like a tic-tac-toe board, and take a depth in every square.

Step 3: Obtain and sort a subsample

Once you have obtained all of your volume measurements, you will need to collect a representative subsample from throughout the catch. You should aim for at least ~20% of the total catch volume for your subsample, in order to get an accurate picture of what is present in the catch pile. Factors such as time, space,

weather, and species composition may affect your ability to achieve this target. Use the range of volumes that you calculated before the haul to determine how many baskets and/or totes of catch you should remove from the pile, to achieve a representative subsample. You can also visually approximate 1/5th of the total catch volume to determine an approximate subsample needed.

If a subsample is too small, or not randomly collected, total weight estimates may be over- or under-extrapolated, giving a false representation of catch composition. Always ensure that your subsample is representative of your total volume (e.g., do not extrapolate a subsample of only discarded fish to a volume of kept and discards). Large or rare individuals should be removed before taking your subsample to avoid over- or under-extrapolating these species. Taking as many actual weights as possible before subsampling will address priorities, make subsampling easier (especially when removing larger species first), and reduce inflating weight estimations from choosing fish that occur at a low frequency.

Be sure to sample from the top, middle, and bottom of the pile to account for possible stratification of catch species. Always fill subsample containers flush to the top; under- or over-filling baskets will make the sample volume smaller or larger than the expected standard volume used in calculations.

Standard subsample volumes:

Orange Basket

$$V = (W_1 + W_2)^2 \times D \times 0.196$$

FSB Standard:

$$W_1 = 1.42\text{ft } W_2 = 1.12\text{ft } D = 1.17\text{ft}$$

$$V = 1.47\text{ft}^3$$



Fish Tote

$$V = (W_1 + W_2) \times L \times D \div 2$$

FSB Standard:

$$W_1 = 1.31\text{ft } W_2 = 1.39\text{ft}$$

$$L = 2.16\text{ft } D = 0.91\text{ft}$$

$$V = 2.65\text{ft}^3$$



55-Gallon Barrel/Cylinder

$$V = (\text{Circumference}^2 \times \text{Height}) \div 12.56$$

Example (no FSB standard):

$$\text{Circumference} = 6.03\text{ft } D = 2.92\text{ft}$$

$$V = 8.45\text{ft}^3$$



Non-Standard Volumes

You can use the above formulas to calculate the volume of other containers used (e.g., milk crates, 5-gallon buckets).

You can also ask the crew if you can use an extra checker pen for your subsample, and measure the volume of that pen as your subsample volume.

After you have removed your subsample from the catch pile, you will need to communicate with the captain to determine disposition for each species. Separate the catch by species and disposition, before obtaining subsample weights for each separate grouping.

You must obtain an actual weight for each grouping with an FSB-approved scale.

If available, and with the captain's permission, you can use extra baskets, totes, or checker pens to aid with the sorting through the catch.

Step 4: Extrapolate the weights

Once you have finished working up the catch, you will need to calculate the Total Volume and Subsample Volume for the haul, following the calculations on the Catch Estimation Worksheet. The calculated ratio between these volumes is called the Sample Weight Multiplier, and is used to extrapolate all subsample weights for the haul. For each species grouping, you will multiply the subsample weight by the Sample Weight Multiplier to determine the total estimated weight.

Example

Before the first haul, you measure and record the length and width of a rectangular checker pen. When the haul is dumped, you note that the catch pile fills the entire checker pen. You obtain 10 representative depths from throughout the catch pile, and fill 8 subsample baskets from throughout the pile.

Total Volume = 5.2ft (length) x 8.7ft (width) x 1.40ft (avg depth) = 63.34ft³

Subsample Volume = 8 baskets x 1.47ft³ = 11.76ft³

Sample Weight Multiplier = 63.34ft³ ÷ 11.76ft³ = 5.39

Subsample:

Monkfish (kept) = 126lbs x 5.39 = 679lbs total

Winter Skate (discarded) = 78lbs x 5.39 = 420lbs total

Step 5: "Reality check" the situation

You should take time to reflect on the extrapolated weights you calculated, and determine if they make sense to you, based on what you witnessed on deck. You can also record a captain's Estimate as a comment if you feel there is a discrepancy between what occurred and how the numbers were extrapolated. You should also comment on any challenges associated with using Volume-to-Volume, or anything that could have contributed to potential math error. Your editor will work with you to ensure that your calculated numbers are as accurate as possible. Make sure you record clear and thorough notes, so you can refer back to them as needed. Always check to be sure you followed the correct math formulas.

Table 2. Troubleshooting guide for common problems with Volume-to-Volume.

Problem	Possible Solutions
Measuring checker pen area	Be prepared - calculate area on steam out, before fishing activity “Keep it simple” - stick to shapes listed on catch estimation worksheet Measure all dimensions to the tenths place
Obtaining depths	Visualize a grid (tic-tac-toe) and take a depth from each section Push depth stick in at angle until it hits the deck, then stand upright Measure down from the top of the checker pen boards, if easier
Conveyor belts Deckloading Fast-working crew	Communicate with crew before fishing starts Review sampling strategies; Have a plan, and back-up plan Get subsamples as soon and as quickly as possible
Collecting subsample	Plan ahead - estimate volume of checker pen and determine how many baskets/totes will be needed (see table below) Visualize a grid (tic-tac-toe) overlaid on the pile and collect subsamples from each section
Storing subsample	Communicate with crew about sampling area Use totes instead of baskets Store sample in an unused checker or pen
Sorting subsample	Communicate with captain/crew Sort by species, then ask crew to sort by kept/discard Account for <u>all</u> species
Calculations/Documentation	Closely read formulas (trapezoids, ovals) Follow decimal place guides on worksheet Double-check calculations Compare to captain/visual estimates, comment when significantly different Avoid excessive species name abbreviations

Cumulative Sum

Cumulative Sum is a method of distributing an actual weight amongst several hauls. It is used when catches from multiple hauls are mixed, and it is no longer feasible to account for catch on a haul-by-haul basis. However, it is possible to obtain an actual weight for the total catch from a number of hauls.

This method can be applied as either a distribution of an actual weight, or as a combination with another estimation method (e.g., basket/tote count or captain’s estimate). In either case, you will divide the total weight of each species grouping, and apply it to all of the hauls that are included. Every haul in the period will have an identical estimated weight record for the species grouping.

Cumulative Sum can be applied to a number of scenarios. However, it should be used after all other preferred methods have been eliminated as options, and catch can no longer be accounted for on a haul-by-haul basis.

Most commonly, it is used when Deckloading occurs, and catch from multiple hauls are dumped on top of each other, without the deck being cleared in between hauls.

Example

During a scallop trip, the crew deckloads for 7 hauls, and then lays up to shuck. You are able to obtain an actual weight on all of the discarded Yellowtail Flounder in the pile after they clear the deck completely.

Yellowtail Flounder (discarded) = 27.4lbs ÷ 7 hauls = 3.9lbs, rounded to 4lbs per haul

Example

During a Redfish trip, the crew deckloads for 3 hauls, then lays up to clear the deck. As they clear the deck, you keep track of the number of baskets being removed, and obtain an average basket weight for each haul. After the deck is cleared, you combine your basket count math.

Redfish, NK (kept) basket count: 43 baskets for the 3 hauls

Redfish average basket weight: (66.3lbs + 67.1lbs + 67.0lbs) ÷ 3 = 200.4lbs ÷ 3 = 66.8lbs

Multiply average basket weight x basket count: 66.8lbs x 43 baskets = 2872.4lbs

Divide total weight by number of hauls: 2872.4lbs ÷ 3 hauls = 957.4lbs, rounded to 957lbs per haul

Combination Estimates

Combination describes a situation where two or more estimation methods are used for a single species and disposition. Always document the methods used as a comment.

Example

You count 87 baskets of kept scallops over a period of 4 hauls. Your scallop meat weight per basket for this watch is 7.2lbs.

87 baskets x 7.2lbs/basket = 626.4lbs

626.4lbs ÷ 4 hauls = 156.6lbs, rounded to 157lbs per haul

Record 157lbs on each of the 4 hauls as a combination estimate.

If weights from two or more estimation methods are added together, document the calculations used to determine each partial weight and record the total weight.

Example

You actually weigh 87lbs of haddock, and visually estimate another 15lbs that were discarded before you could weigh them. Record 102lbs as a combination estimate.

Deckloading

Deckloading occurs when catch from multiple hauls are dumped on top of each other in rapid succession, before the deck is completely cleared. Deckloading may occur for a number of reasons, including weather concerns, or when targeting large schools of fish. It can be an efficient way for crews to fish, as it allows them to reduce the amount of time they are actively operating their equipment. Deckloading allows them to fish hard for a period of time, and then lay up while they process the catch onboard. Catch may or may not be partially cleared between hauls (e.g., crew may be shoveling some baskets, but not clearing the entire deck before the next haul back).

It is important to communicate with the fishermen, to determine if they are targeting a species that is commonly deckloaded (e.g., Sea Scallops, Redfish, NK, etc.). You will also want to determine what your best possible options are for accounting for all of the catch within the deckloading period. The easiest method involves being present for, and observing, all of the hauls within the deckloading period. Keep in mind, the deckloading period will eventually end. The vessel will be limited by factors such as weather and available deck space. The fishermen will not want to leave their kept catch on deck for an extended period of time, allowing the quality to degrade. This is especially a factor during the summer and winter months.

You will need to keep organized notes during the deckloading period. How you handle the catch will vary, depending on which fishery you are in.

Deckloading: Groundfish Fishery

The preferred estimation method for dealing with deckloading on a groundfish trip will be Volume-to-Volume, as it will allow you obtain a subsample from each haul, and account for catch on a haul-by-haul basis. It will be essential that you sample catch from each haul properly. If you do not have enough time to sort through your subsample in between hauls in the deckloading period, you will need to develop an organizational system that will allow you to distinguish between each haul's subsample (e.g., label baskets, draw a diagram of where each haul's subsample is located, etc.).

You will need to keep track of your pile measurements for each part of the deckloading period. You will need to measure the first pile that is dumped on deck, remove a representative subsample, then measure the remainder pile before the next haul is dumped on top. When the next haul is dumped on top, you will re-measure the entire pile (previous haul + current haul). You will then remove a representative subsample from the top portion of the catch pile, to ensure only the current haul is sampled. You will continue this process as long as the deckloading period continues.

If you are able to keep track of the number of baskets and/or totes that are removed from each haul (before the next haul is dumped), then you can calculate the Remainder Volume that way, rather than measuring the remainder pile. Make sure you account for all catch that is removed by you and the crew.

Example

Haul 3 Total Haul Volume = 87.42ft^3 .

You removed 4 baskets for a subsample and the crew removed 10 baskets of kept catch.

Remainder volume for next haul = $14 \text{ baskets} \times 1.47\text{ft}^3 = 20.58\text{ft}^3$

For each haul, sort the subsample by species and disposition, and obtain actual subsample weights. Use Volume-to-Volume calculations to extrapolate to total catch weight estimates. You will continue this process for as long as the deckloading period continues. Once you begin using Volume-to-Volume to estimate weights during a deckloading period, you will need to continue using the method until the deckloading period is over. Keep in mind, you will fill out a Catch Estimation Worksheet and calculate a new Sample Weight Multiplier for each haul in the deckloading period. You will also be calculating the Total Haul Volume for each haul.

Example

You measure a Total Pile Volume of 117.37ft^3 after the current haul is dumped on top of the previous haul. You had measured a remainder volume of 66.86ft^3 after the previous haul.

Current haul's Total Haul Volume =

$$117.37\text{ft}^3 \text{ (Total Pile Volume)} - 66.86\text{ft}^3 \text{ (Remainder Pile Volume)} = 50.51\text{ft}^3$$

If you are unable to utilize Volume-to-Volume for the deckloading period, the other (less preferred) option is Cumulative Sum. Keep in mind that you can use Cumulative Sum as a straight distribution of an actual weight across hauls, or as a combination with other estimation methods (e.g., basket/tote count).

Deckloading: Scallop Fishery

The preferred estimation method for dealing with deckloading on a scallop trip is Cumulative Sum, because it will allow you to obtain actual weights on important bycatch species (e.g., Yellowtail Flounder). It is possible for you to adjust your watch schedule, so you can be present for all hauls in a deckloading period. This can be done, as long as you are still able to achieve your sampling requirements for the trip. You will need to communicate with the captain, to determine if it is feasible for you to start and end your watch schedule with a clear deck. It will benefit both you and the captain if this can be achieved, as it will allow you to use preferred estimation methods (e.g., basket/tote counts, Cumulative Sum) that will result in more accurate weights, rather than having to use extrapolation. If it is possible, you will follow the sampling strategies for Scenario #1.

Scenario #1: Start and end with a clear deck.

Use a basket count for kept scallops (or Volume-to-Volume if necessary), both during the deckloading period, and once they have stopped fishing and have cleared the deck.

Record actual weights on all other species (if feasible), both during the deckloading period, and once they have stopped fishing and have cleared the deck. Keep in mind that Volume-to-Volume is not a preferred estimation method for deckloading in the scallop fishery.

Apply Cumulative Sum to all weights at the end of the deckloading period to determine the estimated weight per haul.

Example

Hauls 4-6 are deckloaded. At the end of Haul 6, the crew sorts through the catch and clears the deck. You count 63 baskets of kept scallops, and weigh a total of 14lbs of Yellowtail Flounder, 46.3lbs of small scallops, and 21.2lbs of sponge.

The meat weight for the On-Watch period is 6.7lbs.

Sea Scallop (kept): 63 baskets x 6.7lbs meat weight = 422.1lbs

$422.1\text{lbs} \div 3 \text{ hauls} = 140.7\text{lbs}$, rounded to 141lbs per haul

Yellowtail Flounder (discarded) = 14.0lbs \div 3 hauls = 4.66lbs, rounded to 5lbs per haul

Sea Scallop (discarded) = 46.3lbs \div 3 hauls = 15.4lbs, rounded to 15lbs per haul

Sponge (discarded) = 21.2lbs \div 3 hauls = 7.1lbs, rounded to 7lbs per haul

If you are not able to adjust your watch schedule to achieve a clear deck at the start and end of your watch, then you will need to adjust your sampling strategies to deal with Scenario #2 or #3 (as applicable). This may occur if the vessel is deckloading for an extended period of time, and you unable to stay on deck for the entire period due to exhaustion, or if safety becomes a concern and you are not able to stay working on deck.

Scenario #2: Start with a clear deck and end with a remainder pile.

Keep track of kept scallops and other catch throughout entire deckloading period (as in Scenario #1).

Measure the remainder pile before going Off-Watch, to determine a remainder volume. Collect a representative subsample from the entire pile (top, middle, and bottom) (see Figure 69).

Use Volume-to-Volume to extrapolate weights for the remainder pile, and then combine extrapolated weights with weights obtained during the deckloading period. You will need to remember to convert the volume of kept scallops on deck into a basket count, and combine with the baskets already counted. This entire basket count should be converted to a dressed weight.

Use Cumulative Sum to divide all weights across the deckloading period (may have combination estimation methods).

Example

You are scheduled to go Off-Watch on Haul 150. Hauls 147-149 have been deckloaded, and the crew tells you they will not be clearing the deck for at least another 5 hauls. You decide you are too tired to stay on deck for that much extra time, so decide to account for the catch that is present, and go Off-Watch as planned.

Measure the remainder pile volume.

Collect, sort, and weigh your subsample (which represents 3 hauls worth of catch).

Extrapolate the weights using Volume-to-Volume.

Divide all extrapolated weights by 3 and apply all estimated weights to Hauls 147-149.

Scenario #3: Start with a remainder pile on deck.

You will need to adjust your sampling strategy to ensure that catch from the remainder pile is not accounted for on new observed hauls.

Measure the remainder pile (that is present before you are On-Watch), to determine a remainder volume. Measure the total pile, after the first pile of the On-Watch period is dumped on top of the remainder pile. Calculate the volume for the current haul by subtracting the remainder volume from the total volume.

Collect a representative subsample, from the top portion of the catch (so as to avoid the catch from the remainder pile) (see Figure 70).

Use Volume-to-Volume to extrapolate out the weights.

Continue to repeat process for all hauls in the deckloading period (must continue using Volume-to-Volume until the deck is cleared).

Be organized with your notes, so you can keep all of the pile measurements in order.

Keep in mind, if standard volumes are removed from the pile (e.g., baskets and/or totes), then you can use those to calculate remainder volume (rather than re-measuring the pile each time). Be sure all removed catch is accounted for.

Example

You come On-Watch for Haul 33, even though there is still a fairly large pile on deck. The crew tells you that they will not be laying up to shuck and clear the deck for at least another 4 or 5 hauls. You decide that since the weather is supposed to worsen later in the day, that you should aim to observe as many hauls as you can before safety becomes an issue.

The remainder pile when you come On-Watch has a volume of 121.45ft³.

After Haul 33's catch is dumped on deck, you re-measure the total pile and calculate a volume of 154.67ft³.

Total Haul Volume (for Haul 33): 154.67ft³ – 121.45ft³ = 33.22ft³

You collect a 6 basket subsample from the top of the pile, and extrapolate the weights.

To determine the remainder pile volume before the next haul, you subtract the number of baskets you took as a subsample (6) and the number of baskets of kept catch that the crew removed (23).

29 baskets x 1.47ft³/basket = 42.63ft³

154.67ft³ – 42.63ft³ = 112.04ft³ remainder pile volume

Continue using Volume-to-Volume until deck is cleared.

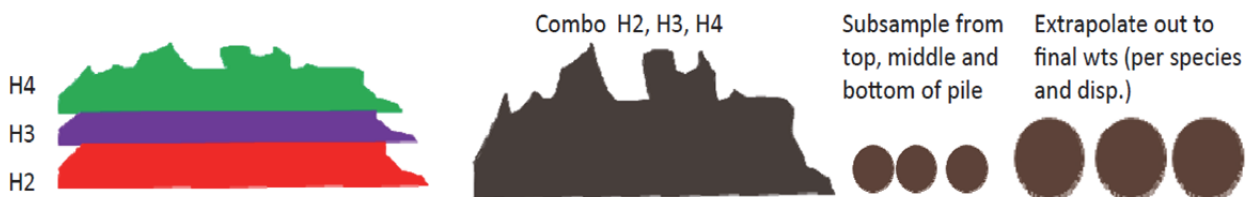

Figure 69. An example of scallop deckloading ending with catch on deck.

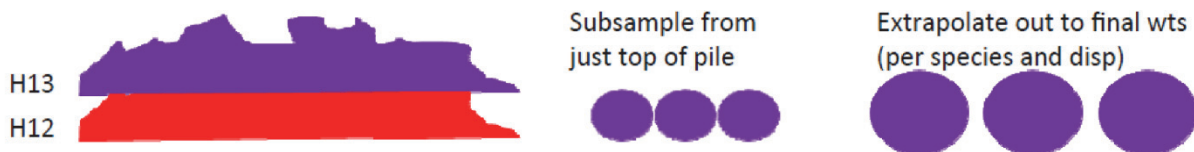

Figure 70. An example of scallop deckloading starting with catch on deck.

Conveyor Strategies

Some trawl vessels will use a conveyor belt to speed up the catch sorting process. The conveyor will start with a “hopper” in the checker pen. The crew will put the deck hose in the checker pen to flood the pen, and facilitate catch moving toward the conveyor belt. Catch will run along the conveyor and down a chute. Depending on the situation, the chute can be set up to direct discards back into the ocean, or in some cases may be moved to send kept catch directly into the fish hold (see Figure 71). Catch estimation on these vessels may present some unique challenges. Effective communication between you and the vessel crew will be crucial.

In an ideal situation, the crew will be picking discarded catch from the conveyor, which can then be set aside for you to weigh or subsample. Basket/tote counts can then be used to obtain kept catch weights. If this is not possible, use one of the three strategies below to estimate catch, listed in order of preference.

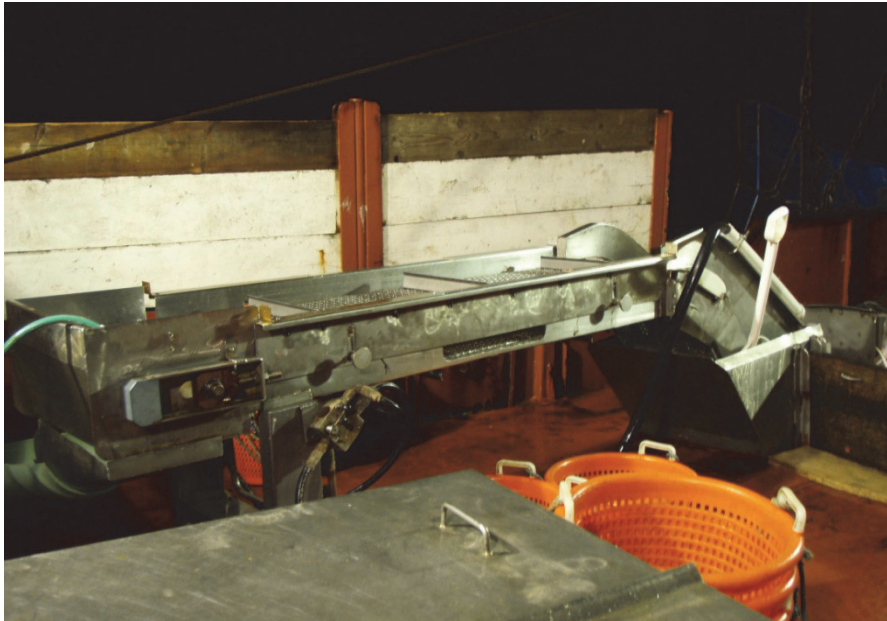

Figure 71. Conveyor belt with checker pen (on right) and discard chute (on left).

Strategy 1

This strategy can be used when the crew is picking kept catch from the conveyor, and the discard chute can be removed. Collect all discards in full flush baskets/totes from the end of the conveyor. Keep an accurate count of all discard baskets. If there is a large volume of discards, periodically set a basket aside as a subsample, aiming for 20%, or 1 in 5 baskets. Be sure to distribute baskets evenly throughout the sorting process to ensure accurate representation. Use the Volume-to-Volume method to extrapolate discarded catch weights.

Example

The captain and crew take off the discard chute for you before sorting operations commence. You fill one basket of discards from the end of the conveyor. When it is full, set that basket aside and begin filling a second basket. When the second basket is full, discard the contents into the water, and do the same for the next 3 baskets. When the 6th basket is full, keep it aside, and begin filling a new basket. Repeat until the end of the sorting period, and then sort and weigh your subsample.

At the end, you have collected 6 subsample baskets out of a total of 32 baskets discarded. Your sample weight multiplier is $32 \div 6 = 5.33$. Apply this multiplier to the weights of discarded catch in your subsample. Obtain actual weights for the kept catch, or use one of the other estimation methods.

Strategy 2

This strategy can be used if the volume of discards is too great to keep 1 out of 5 baskets, or if you cannot keep an accurate count of the total number of baskets discarded. If this is the case, you can estimate the volume of discarded catch. Measure the total volume of the catch in the checker pen **before the pen is flooded**. Obtain subsample baskets of discarded catch throughout the entire sorting process.

Determine the volume of kept catch by recording the exact numbers of baskets and totes of kept catch, and multiplying by the known volume of the container used. You can also use these numbers to estimate the kept weights. Estimate the discard volume by subtracting the volume of kept catch. Extrapolate the discard subsample weights to the estimated discard volume, following the Volume-to-Volume calculations.

Baskets and totes of kept catch must be **round** catch to provide an accurate volume estimation. Dressed kept catch should not be used to estimate volume for this strategy. Captain's estimates should also not be used for this strategy.

Example

You calculate the total volume of all catch as 87.56ft^3 . The crew has filled 23 flush totes of round kept catch. You collected 4 baskets of discards.

Volume of kept catch = $23 \times 2.65 = 60.95\text{ft}^3$

Volume of discarded catch = $87.56 - 60.95 = 26.61\text{ft}^3$

Subsample volume = $4 \text{ baskets} \times 1.47\text{ft}^3 = 5.88\text{ft}^3$

Sample weight multiplier = $26.61 \div 5.88 = 4.53$

Apply this multiplier to the discarded catch in your subsample.

Strategy 3

This strategy should be used when it is not possible to collect a subsample at the end of the conveyor. Measure the checker pen **before it is flooded**, and obtain ten representative depths to calculate the total catch volume. Collect a subsample of the mixed kept and discarded catch from the checker pen. This subsample will be used to extrapolate catch weights with Volume-to-Volume. Kept catch weights should be

obtained by actual weights or basket/tote counts, but you should include kept catch weights generated by Volume-to-Volume in the comments section for comparison.

For species that the crew is both keeping and discarding, either

- a. Have the crew sort through the subsample to distinguish kept and discarded individuals, or
- b. Keep kept and discarded as one unit, extrapolate the total weight using Volume-to-Volume, and then subtract the weight of calculated kept catch. (Only use for species with one discarded disposition code)

Example

The crew tells you they are keeping some of a particular species, and discarding some that are too small for market. There are 220 pounds total of that species in the subsample. The sample weight multiplier has been calculated as 5.70.

Total pounds in catch pile (kept and discarded): $220\text{lbs} \times 5.70 = 1254\text{lbs}$

Total pounds minus estimated kept weight: $1254\text{lbs} - 1021\text{lbs kept} = 233\text{lbs discarded}$

Catch Composition

Catch composition is a technique intended for the sampling of hauls where the size of the catch, or the method in which it is handled, precludes the use of all other sampling-based estimation methods. This method will most commonly be used on purse seine and midwater trawl hauls targeting Atlantic herring. It may also occur on exceptionally large hauls in the bottom otter trawl fishery, most often when the vessel is targeting shortfin squid, Atlantic longfin squid, scup, or Atlantic herring.

The exact protocols for catch composition vary, depending on whether catch is being brought onboard in the codend, or pumped out of the net while the codend is still in the water. On midwater vessels, the fish may be pumped onboard or hauled onboard into holding pens. The fish are then directed through a series of chutes into fish holds and stored in running seawater tanks for transport back to port.

Notify the captain at the beginning of the trip that you need to view all catch, regardless of whether it is brought onboard the vessel or not.

Catch Pumped Onboard

On most purse seiners and midwater trawlers, as well as some bottom trawlers, catch will not be brought onboard in the codend or bunt section of the net. Rather, the crew will bring the codend or bunt up alongside the vessel in the water, and insert a mechanical pump into the net to pump the fish onboard. The fish will be pumped up through a flexible tube and deposited into the fish hold, however, sometimes catch is processed through a series of chutes along the way.

In some cases, the crew will pass the pumped catch through a grate prior to the fish hold to remove large species (e.g., dogfish, groundfish, lobster). If large fish are being picked out at the grate, request that the crew keep them aside for you to weigh and sample after pumping operations are complete. Basket subsamples should be collected before fish pass through any other sorting devices.

On a pumping vessel, once the codend or bunt has been brought up alongside the vessel, after haul back but prior to pumping, ask the captain what the estimated pumping session duration will be for that haul. If pumping operations are paused at any time due to clogging or readjusting of the pump, position yourself on the side of the vessel with a clear view of the pump to observe any large animals, such as incidental takes.

Estimating Pumping Time

Vessels commonly have sensors placed on various parts of the net, often called “eggs.” These devices send data electronically to the wheelhouse to indicate how much catch is contained within the net. Based on the percentage of catch within the net, the captain can estimate how much catch is present and how long it will take to pump the entire catch onboard.

First, place ten empty baskets on deck near the chute where fish will enter into the fish hold. Next, divide the estimated pumping time by ten to obtain a reference sampling interval; sometimes the fish will begin to flow immediately, other times there will be only water for the first few minutes. As soon as fish begin to come onboard, record the time, and hold a basket under the stream of fish, until the basket is filled flush to the top. If catch volume or the location of the sample collection station precludes collection of full baskets, fill two half baskets and combine. Hold the basket firmly so that it does not fall into the fish hold.

Timing of each successive sample begins after the first basket, using the sampling interval calculated. This process of filling sample baskets and using the sampling interval continues after each basket is filled, until the pumping process is complete.

Example

The captain estimates that it will take 20 minutes to pump the catch onboard. By dividing 20 minutes by ten baskets, you achieve a sampling interval of two minutes between samples. Pumping begins at 13:30, however for the first five minutes only water comes onboard. At 13:35, you see fish begin to come down the chute.

Firmly hold your basket over the hatch opening to the fish hold until the basket is full, and set it aside on the deck. Fill additional baskets at 13:37, 13:39, 13:41, 13:43, 13:45, 13:47, 13:49, 13:51, and 13:53. At 13:54, the last of the catch comes aboard, and the pump shuts off.

In practice, sampling from a fish pump is rarely quite that smooth. The pumping process usually does not proceed uninterrupted from the first fish to the last fish, and the captain’s estimated pumping time is usually, at best, a rough estimate.

When there is an interruption in the pumping process that causes fish to stop being pumped onboard, your sampling interval is also disrupted. Once the pumping process begins again, resume taking basket samples following your sampling strategy prior to the interruption.

Example

The captain estimates it will take one hour to pump the catch onboard. Sixty minutes divided by ten baskets is six minutes between samples for your sampling interval. Fish begin coming onboard at 16:40 and you obtain the first basket. You take additional baskets at 16:46 and 16:52, with the next sample scheduled for 16:58. However, at 16:54, fish stop coming through the pump. You check with the captain and crew to see if fishing has concluded or an issue has occurred (e.g., the pump is clogged by an incidental take).

The issue seems to be that the pump requires lower placement in the net to access where the fish are located. The crew makes the necessary adjustments, and fish begin coming through the pumping system again at 16:57. If it weren't for the interruption, you would have taken your fourth basket at 16:58. However, since there were three minutes when fish were not being pumped onboard, you must omit these three minutes from your sampling interval between the third and fourth baskets.

Provided that there are no further problems, you obtain your fourth basket at 17:01, return to the six-minute sampling intervals, and take successive baskets at 17:07, 17:13, 17:19, 17:25, 17:31, and 17:37.

Fewer than 10 basket samples taken

If the captain overestimates the pumping time, the pumping process will finish prior to the completion of your ten basket sample. This is acceptable, since you followed protocol and could not have foreseen this situation. It is important that you remain with your established sampling intervals, and do not reduce your sampling interval in the middle of the pumping process to increase your sample size. Catch is often stratified in the net, and an even sampling interval is necessary to ensure that some parts of the catch are not over-sampled.

Example

The captain estimates pumping will take thirty minutes; your calculated sampling interval is three minutes. You collect your first basket when the first fish come onboard, at 12:03. You collect additional baskets at 12:06, 12:09, and 12:12, and 12:16. The pump shuts off at 12:18, leaving you with only half of your sample with five baskets.

More than 10 basket samples required

If the captain underestimates the pumping time, you will have filled all ten of your baskets prior to the completion of the pumping process. If you have access to extra baskets, continue to fill baskets at the determined sampling interval until the end of the pumping process. However, if pumping continues and you run out of baskets, you will have to revise your sampling interval collection scheme.

First, dump all even-numbered baskets you have already collected into the fish hold without sampling them, beginning with the second basket. The sampling interval time between baskets will then be doubled. Employ

this revised sampling interval immediately by utilizing the newly emptied baskets. Continue to collect baskets on the new sampling interval until pumping has finished.

Do not attempt to free up baskets by sorting and weighing your samples while pumping is still in progress, as you are required to monitor the grate and pump head to ensure that you do not miss any large fish or incidental takes.

Example

The captain tells you that pumping will take 20 minutes, or a two minute sampling interval. You collect the first basket when the first fish come onboard at 14:00, and collect additional baskets at 14:02, 14:04, 14:06, 14:08, 14:10, 14:12, 14:14, 14:16, and 14:18. By 14:20, pumping is still not complete; fortunately, you have three extra baskets available. You fill them at 14:20, 14:22, and 14:24. However, pumping is still not complete at 14:26, so you begin to empty the baskets collected at 14:02, 14:06, 14:10, 14:14, 14:18, and 14:22 directly into the fish hold.

Your sampling interval now doubles from two minutes to four minutes. Since the last basket collected and kept was filled at 14:24, you collect a basket at 14:28. You fill additional baskets at 14:32, 14:36, and 14:40. Pumping finishes at 14:43. In total, you have baskets collected at 14:00, 14:04, 14:08, 14:12, 14:16, 14:20, 14:24, 14:28, 14:32, and 14:36.

Remember to always write down the time at which each basket is sampled. Also record the times of any breaks in the pumping process, along with the reasons for those breaks.

Example

The captain tells you pumping will take ten minutes, or one minute sampling interval. Pumping begins at 03:57, but no fish come aboard until 04:00. You collect baskets at 04:00, 04:01, 04:02, 04:03, 04:04, 04:05, 04:06, 04:07, 04:08, and 04:09. Pumping continues, so you fill three spare baskets at 04:10, 04:11, and 04:12. The pump is still running at 04:14, and you are out of baskets, so you dump the baskets you took at 04:01, 04:03, 04:05, 04:07, 04:09, and 04:11. You fill five more baskets at 04:14, 04:16, 04:18, and 04:20.

At 04:20, you smell smoke, and pumping stops. The engineer identifies a burnt-out component in the pumping system, which will be repaired at sea. While he is working, you keep an eye on the net for marine mammal interactions. The repairs are completed at 05:13, and pumping resumes. Fish begin coming through the system again at 05:17. You wait until 05:19, the point at which fish have been coming through the system for two minutes since your last sample, and fill basket number twelve. You fill your thirteenth basket at 05:21. Pumping continues.

You have baskets from 04:00, 04:02, 04:04, 04:06, 04:08, 04:10, 04:12, 04:14, 04:16, 04:18, 04:20, 05:19, and 05:21, so you dump the baskets collected at 04:02, 04:06, 04:10, 04:14, 04:18, and 05:19. You fill up one more basket at 05:25, four minutes after your previous one at 05:21. You now have eight baskets. At 05:26, the deck boss tells you that pumping will be complete in another minute, and tells you to hurry up if you want to fill your last two baskets. You explain that it is more important to have the baskets evenly spaced through the pumping process than to fill all ten. Pumping finishes at 05:28. The baskets you still have were collected every four minutes of actual pumping, at 04:00, 04:04, 04:08, 04:12, 04:16, 04:20, 05:21, and 05:25.

Catch Hauled Onboard

When a large volume of catch is hauled onboard and dumped on deck, first consider using the Volume-to-Volume method. If this method is not an option, as fish are immediately being pushed through deck plates into the hold prior to obtaining depths, the Catch Composition method will be necessary.

In these cases, the crew will usually have to “split the bag” in order to bring the entire catch onboard. This means that the rearmost portion of the catch within the codend will be hauled onboard with a crane, while the bulk of the catch remains in the net within the water. Once a portion of the catch has been dumped on deck, the codend will be closed again and returned to the water. The net will then be drawn further up the reel, forcing more fish into the codend. The process of splitting the bag will be repeated until all catch is onboard.

Employ the catch composition sampling strategy, by dividing the ten baskets amongst the estimated number of split bags. The resulting number of baskets will then be taken from each new pile of fish. When calculating baskets per split bag, it is possible to have partial baskets per pile.

Example

The captain of a bottom trawler catches a very large, clean haul of scup. After seeing the net at the surface, he estimates he will need to split the bag four times in order to safely get all his catch onboard. Because the catch is so clean, he decides he will open the deck plates and push the catch directly into the fish hold, instead of picking through it. Four bag splits divided by ten baskets is 2.5 baskets per split bag pile. After the first bag is dumped on deck, you fill two baskets completely, and fill a third basket halfway. After the second bag is dumped, you fill the rest of your half-full basket, and then fill two more baskets completely. You repeat this process with the third and fourth bags.

As with Volume-to-Volume, obtain a representative sample that incorporates fish from several parts of each pile. Unlike pumped catch, catch from split bags may be sampled while you are waiting for the crew to bring the next part of the bag onboard, however only if it is safe to do so. Additionally, bottom trawlers will have many more baskets available than the type of vessels that usually pump their catch. Running out of baskets should therefore not be an issue in most cases. If you do run out of baskets, free some up by dumping them in a manner that maintains the most even distribution of samples across the haul as possible.

Mixed, Unsorted Kept Catch

Catch Composition may sometimes be the most efficient method for sampling large quantities of mixed kept catch that is being sold unsorted, even when the catch is brought onboard in a single bag. The most common situation is barrels of mixed little and winter skates. After the crew has separated mixed kept catch from the discards and any other kept catch, collect ten baskets or approximately 20% of the kept catch, whichever is less. As always when subsampling, sample representatively and do not collect all samples from the same location.

Final Catch Calculations

After all kept catch has been stowed, ask the captain to estimate the weight of kept catch, and convert his answer to pounds. One truck, the measure typically used in the herring fishery, is 40,000lbs¹². If the captain gives you the estimate in tons, clarify whether it is using short tons (2000lbs) or long/metric tons (2200/2205lbs). While short tons are much more common, river herring avoidance programs require captains to report their catch in metric tons, and the captain may give you this value.

To calculate the weight of each species in the haul, first sum the total weight of each species across all basket samples. Next, sum the total weight of all species from all sample baskets. Divide the weight of each species by the total weight of all species to determine the proportion of your sample made up of that species. Finally, multiply the calculated proportion of each species by the captain's total weight estimate to determine the weight of each species in the kept catch.

¹² Must be confirmed with the captain.

Example

You add up the weights for each species across all basket subsamples to obtain the following totals:

Atlantic herring = 759lbs

Blueback herring = 8.1lbs

Atlantic mackerel = 35.2lbs

The total weight of all species in all baskets is $759 + 8.1 + 35.2 = 802.3$ lbs

Divide each species weight by the total to obtain the proportion:

Atlantic herring = $759 \div 802.3 = 0.9460$

Blueback herring = $8.1 \div 802.3 = 0.0101$

Atlantic mackerel = $35.2 \div 802.3 = 0.0439$

The captain tells you the total pumped weight was approximately 200,000lbs. Multiply each proportion by this estimate to obtain the final estimated weight for each species:

Atlantic herring = $0.9460 \times 200,000 = 189,200$ lbs

Blueback herring = $0.0101 \times 200,000 = 2,020$ lbs

Atlantic mackerel = $0.0439 \times 200,000 = 87,800$ lbs

Species in the basket samples are extrapolated across the entire catch, and should represent what is being pumped into the fish hold. If you think that the total amount extrapolated will not be representative, include a comment with a tally or visual estimate so you can discuss with FSB staff at the end of the trip. Do not remove fish weights from your subsample calculations.

Marel Scales

Marel scales are electronic, motion-compensating digital scales designed for use in the marine environment. While these scales can give a more accurate weight readout on a moving boat (compared to spring scales), they require additional maintenance and troubleshooting procedures. These scales come in two sizes: one larger that is heavier but can handle a larger load, and one smaller and lighter than can handle a smaller load.

The complete Marel scale package consists of:

- The Marel scale itself,
- A pelican case with laser-cut foam for protect during transport and storage,
- A 5kg calibration weight,
- 3 sets of batteries (stored in Ziploc bags),
- 1 tube of Silicone grease, and
- A paperwork packet consisting of additional Marel Scale Worksheets, instruction form, and laminated reference guide.

Marel scales are tracked by the serial number located on the **display face of the unit** (see Figure 72). There is an additional number on the metal handle that should not be used. The pelican case is also numbered and associated with the specific Marel scale contained within. The case number is located on the lid, on top of the pelican case next to the handle, and on the inside of the case. Scales should never be swapped between cases.



Figure 72. Marel scale showing location of serial number.

A fully packed scale in its case weighs 76.5lbs (large scale) or 39.5lbs (small scale). The case will float if dropped overboard and is water-tight, assuming all latches are fully secured. Although the scale is designed for marine use, it should never be stored in standing water. The scale should be transported at all times in the pelican case. Calibration weights should only be taken out of the pelican case when being used. Dead batteries should be discarded immediately and not stored in the case. The foam is also water proof; if water enters the case, leave it upside down to drain.

Setting up the scale for use

Take the scale out of the case and remove the weigh pan. Put the batteries in the battery casing and attach to the scale. Before attaching the battery casing, apply a small amount of silicon grease to the threads and O-ring of the casing and the unit. The battery casing should be screwed on finger tight only. **Do not overtighten**. This is a weak point and overtightening can cause the casing to break or become stuck.

Press any button to activate the scale. It will then read "Press Up". Press the ^ UP button to turn the scale on. The scale should read "U2 – 3.70"; this means it is booting up. Place the weigh pan back on the scale. The lower left display may blink between "1" and "CAL". If it's not, that's okay. Anytime the lower left flashes "CAL" a calibration should be performed.

Calibrate the scale **every haul**. Place the calibration weight on the weigh pan, and record the weight readout. The acceptable calibration weight range is 11.00 to 11.10 lbs. If it is out of range, perform a daily test.

Do not use the scale if it has sustained major damage, or any part of the scale is broken. If this happens during a trip, stop using the scale and switch to your spring scales.

Daily Tests

This test must be performed and recorded once every observed day. In certain cases (e.g., bad weather), several tests must be done.

1. Start the test.
 - a. Press 'MENU' and 'ZERO' simultaneously. Do not place anything on the scale at this time.
 - b. Wait until the scale reads 'PUT 5'.
 - c. Place the 5 kg calibration weight on the scale and press 'PRINT'.
 - d. The scale should display a fit value between 0-99. For example, it will read 'FIT 2'.
 - i. The lower the fit the better. The best fit possible is '0'. The worst fit value that may be displayed is '99'. If the fit value is above 99 an Error message will generate (E-91).
 - ii. Calm weather fit value: < **25** in order to proceed.
 - iii. Rough weather fit value: < **70** in order to proceed.
 - e. If the fit exceeds the above values, repeat the test. Depending on the conditions, multiple tests may be needed before an acceptable fit value is achieved.
2. Remove the calibration weight.
 - a. The scale should read '0.00'.
 - b. If it doesn't read '0.00' make sure nothing is touching the scale, especially the sides, and that it has been zeroed.
 - c. If it does not read '0.00' after zeroing, repeat the test.
3. Put calibration weight back on the scale.
 - a. The acceptable calibration weight range is 11.00-11.10 lbs.
 - b. If out of range, repeat the test up to 3 times before switching to spring scales.

Once the calibration weight and fit value are within the acceptable ranges, the scale is ready to be used.

Storing the scale on deck

It is your responsibility to communicate with the captain and crew when setting up a station (e.g., don't set the scale up in an unused checker pen assuming that catch will not be dumped there). Find a safe but reasonable sampling station to set up the scale and leave it there. When possible, set the scale up in a sheltered location. The scale is designed to compensate for motion, but it is susceptible to wind.

Make sure that nothing is touching the scale from the top or the sides. Any object leaning up against the scale will affect the performance of the scale. The scale may be tied down by the feet or the holes drilled into the handles, to keep it from sliding. Putting the feet through the holes of a rubber mat may keep it from sliding around on deck.

Maintenance

In between hauls, the scale can be placed in sleep mode. To do this, press 'Menu' and 'Down' simultaneously (the scale is set to go in sleep mode after period of inactivity). This will conserve battery power. To 'wake' it up, press any button. Find a secure location to stow the scale in between hauls. In decent weather the scale may be secured and left on deck. In bad weather, the scale should be stowed off deck in a secure location.

After the trip, wash the scale with **fresh water and a mild soap** (e.g., dish soap). Use a soft sponge or cloth to wipe down the display screen. **DO NOT** use a scouring pad; this will damage the face and make it difficult to read. Use a green scouring pad to remove any rust spots on metal parts if necessary. Remove the weigh pan, and rinse and clean the entire scale with fresh water. Allow the scale to air dry outside of the case.

Inspect all cables and the battery casing for signs of damage. Wash the pelican case with fresh water. Use a mild soap when needed. Turn the case upside down and allow to air dry.

Challenges

- Logistics:
 - This is a bulky and heavy piece of equipment. At times, it will require the assistance of the crew or your employer to load/unload.
 - If possible, use a mechanical advantage when loading/unloading (e.g. crane or winch). When doing this make sure that you use as many points on the pelican case as possible. If using a rope, loop the rope through a minimum of 2 handles. The pelican case is rugged, but the durability is unknown and poses a safety hazard.
 - Crossing several boats to get the scale on is challenging and dangerous. When possible, communicate with the captain for a possible alternate location to load your gear (e.g. ice house, dealer).
- Housing Situation:
 - If there is no room where you're staying, **DO NOT LEAVE YOUR SCALE IN AN UNSECURED LOCATION!**
 - You may store your scale in a company office or storage locker.
 - If you have a storage shed, garage, or enclosed porch, lock it up there.
- Vehicle Accommodation:

- If your vehicle can't accommodate the scale, coordinate with your company for assistance delivering your scale to a vessel.
- If the scale can be secured on the vessel, drop it off prior to departure whenever possible.
- Small Vessels:
 - Using the larger scale on smaller vessels can be a challenge. The smaller scales can typically be brought on small boats.
- Boarding a vessel by skiff:
 - Do not put yourself in danger. Communicate with the captain to see if he will bring the boat to the dock. If he refuses, do not take the scale in the skiff.
- Boarding a vessel in a location with big tides:
 - Do this only if you can safely lower or raise the scale to the vessel.
 - Some docks have a crane available to fishermen that may be used to load /unload the scale. Observers should not be operating machinery. This must be coordinated with the captain/crew or dock personnel.
- Leaving the scale in your vehicle:
 - Be sure to properly secure the scale in your vehicle if you must leave it. Lock all doors and cover the case with a blanket, tarp, etc.
 - When possible, coordinate with your employer to pick it up. Some observers have also been able to leave it in a port office or storage shed.
 - Do not leave the scale in the back of a pickup truck!
 - Be proactive. If you're able to speak with the captain or visit the vessel prior to sailing, find out if you are able to bring the scale before you are due to sail.
- Screen display is difficult to read in direct sunlight:
 - Hang the edge of the basket over the display screen to shade the screen.
 - Place in a shaded location.
 - Use your hand, clipboard, etc. to shade the screen.
- Sudden impacts:
 - The scale is especially sensitive to side impacts. If your scale sustains a sudden impact (someone kicks or tips over it, a basket/tote slams into the side, it's dropped), check to make sure there is no visible damage and recalibrate before use.
 - Avoid dropping weight on the scale, especially from a height. The scale is designed to sustain these types of impacts, but it may throw the calibration off. Check for visible damage and recalibrate.
- The scale is not achieving a reasonable fit, multiple error codes are displayed, the scale will not zero, or the display reads significant fluctuations:
 - If anything is touching the sides of the scale, it will not work properly. Ensure it is free and clear of all objects.
 - If anything is pressed up on either of the load cells, the scale will not work properly. Ensure the load cells are clear and moving freely.

Tips

To reset the scale, press “MENU”, “UP”, and “0” simultaneously (referred to as “the claw”). This is the preferred method for resetting a scale, but you can also unscrew the battery casing and reconnect it.

To put the scale to sleep, press “MENU” and “DOWN” simultaneously.

If you get a message that says “CODE”, it is likely that “0” and “TARE” were pressed instead of “0” and “MENU”. To exit this, press “MENU”, pause, and press “MENU” again.

To clear an error message, press “MENU”, possibly several times. Do this slowly, allowing at least 5 seconds before pressing “MENU” again.

Once the scale is calibrated, it can be picked up and moved if necessary. Care should be taken when moving the scale. It is heavy and may pose a safety hazard when moving on deck.

The laminated reference guide included in the case contains:

- Upkeep and Maintenance Instructions
- Error Code list
- Calibration instructions
- Daily Test instructions
- Quick Fixes
- FSB Contact Information

Notes

Biological Sampling

Safety concerns

While sampling portions of the catch, you will be handling live marine life. Be aware that many species have sharp teeth and spines that can cause puncture wounds. Always use caution when handling catch on deck. In addition, you may need to use a knife to obtain age structures from certain species. This can present some additional safety concerns while on a moving vessel. Remember to keep your knife sharp and in good working order.

Individual Animals

Individual Animals include all pelagics, sturgeons, tagged fish, and shellfish. These species should take priority over other catch information, except for Incidental Takes. All Individual Animals should be photographed.

“Pelagics” include, but are not limited to:

- Swordfish
- Atlantic Needlefish
- Torpedo Rays
- Billfish
- Tuna
- Cutlassfish
- Sharks
- Bonito
- Wahoo

It is important to ensure that a weight is recorded for every animal (except chunked fish carcasses and only heads of animals).

If a terrapin is encountered in any fishery, record it as an Individual Animal. Do not record it as an Incidental Take.

Individual Animals must be recorded for every haul (whether observed or unobserved). For each Individual Animal, an actual or estimated weight should be obtained. In general, the types of weights you should be able to obtain are as follows:

- Kept Pelagic Species: The dealer’s actual dressed individual animal weight for those species tagged and carcass weights obtained dockside, *e.g.*, swordfish, billfish, tuna, bonito, sharks, etc.
- Discarded Pelagic Species: The observer’s estimated round individual animal weight for those species discarded, *e.g.*, swordfish, billfish, tuna, bonito, sharks, etc. When possible, record round weights before the animal is gutted, filleted, etc.
- Upgraded or High Graded animals: when a previously kept fish or shark is discarded and replaced with one that is larger (or of higher quality/value), change the original kept record to a discard with the upgraded disposition, and the new kept animal on the haul in which it was caught.

Length Measurements

It is important to collect at least one measurement from each Individual Animal (some species may require two), and determine the sex of as many animals as possible. If an Individual Animal has been dressed before you can measure it, do not try to piece the animal back together. If the biological standards are missing on the animal, record any length measurements in comments.

Example: Measurements can be collected on a shark that is missing its dorsal fin. Measurements cannot be collected on a shark that is missing its caudal fin.

See the [FSB Observer On-Deck Reference Guide](#) for specific sampling requirements by species.

Check all Individual Animals for tags.

These tags may be from:

- a) A kept pelagic fish tagged with a carcass tag. This tag allows you to uniquely identify each kept fish carcass, for the purpose of recording its actual, dressed weight at the dealer. Record the tag number as it appears on the carcass tag.
- b) A tag recaptured fish or shark. If the animal is kept by the vessel, record both the recaptured animal tag number, and the carcass tag number in this field.
- c) A data storage tag. These are small computers attached to fish that can collect temperature and pressure data. Tag numbers are usually written on the backs of the tags.

Length Frequencies and Age Structures

Length frequencies and age structures can aid in determining the effect of fishing effort on catch size and species distribution. These data are also useful in establishing length-weight relationships, ageing, migration patterns, food habits, and other valuable ecological correlations. Biological sampling should generally occur during or after every other observed haul, as specified in the [FSB Observer On-Deck Reference Guide](#). Whenever possible, observers should sample every haul.

For those hauls that are biologically sampled, length frequencies and age structures are to be collected on kept and discarded catch, based on the priorities assigned to that fishery, program, and statistical area. Additional samples may be taken at times - these include specialty sampling requests from end users. If time is limited, it is appropriate to focus on discarded catch first, as discard data can only be collected by observers. It is also appropriate to focus on achieving sampling targets for one species and disposition, before moving on to the next, when possible. This allows for a more robust data set for the end users. Since every fishery, every trip, and every haul may be different, sampling procedures must be adapted to each unique situation.

Make sure you weigh the fish that you measure, before either discarding them or giving them back to the crew. If you are measuring multiple individuals of the same species and disposition code, they can be weighed as an aggregate, and then measured one by one. Also note that for some species, NEFOP and IFS observers will need to separate the individuals by sex before measuring them. Information on what species should be separated by sex can be found in the [FSB Observer On-Deck Reference Guide](#).

Before measuring fish species, insert a Length Frequency strip into the Finfish Length Frequency Board (see Figure 73).

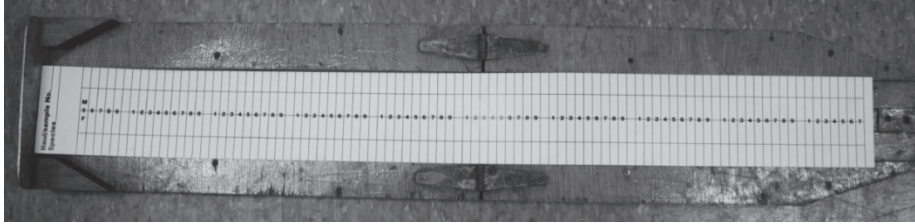

Figure 73. An example of the finfish Length Frequency Board and Length Frequency strip being used in conjunction with each other.

Check the [FSB Observer On-Deck Reference Guide](#) for the required length type for the species you are measuring. Once you have determined the appropriate type of length measurement that is required, you should place the individual's head at the tall edge of the length board, and measure to the appropriate location for that species (whether it be a fork length, total length, etc.). Mark the length on the length frequency strip or record in a waterproof notebook (see Figure 74).



Figure 74. Example of where to mark the Length Frequency strip for a Fork Length measurement.

Age Structure Sample Collection

Check the [FSB Observer On-Deck Reference Guide](#) for the required age structure type for the species you are measuring. Age structures are not required for all species, fisheries, or programs.

Taking otoliths requires cutting through either the head (see Figure 75) or gills (see Figure 76).



Figure 75. Cutting through a fish head to remove otoliths.

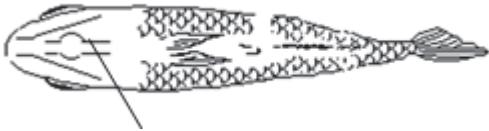
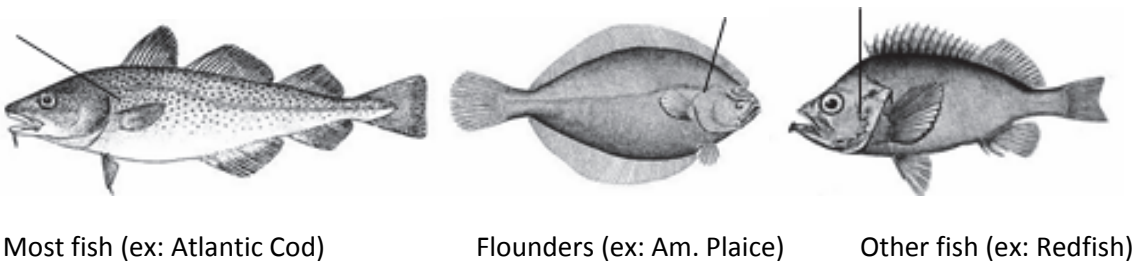

Figure 76. Accessing otoliths by cutting through the ventral side of the fish (gills may have to be removed).

The angle of the head cut varies by fish type (see Figure 77). You should remove both otoliths (see Figure 78) from the same animal and place in a single age sample envelope.



Most fish (ex: Atlantic Cod)

Flounders (ex: Am. Plaice)

Other fish (ex: Redfish)

Figure 77. Necessary angle to cut various fish to remove otoliths.

	ATLANTIC COD		REDFISH
	POLLOCK		SILVER HAKE
	BUTTERFISH		ATLANTIC HERRING
	WHITE HAKE		HADDOCK (>65cm)
	WITCH FLOUNDER		WINTER FLOUNDER (>35cm)

Figure 78. Examples of otoliths from a variety of fish.

Scale samples are taken by running your knife against the scales from rear to front in the specified area (see Figure 79). Do your best to remove mucus, debris, and epidermis from the fish before collecting scales. Only scales collected from the proper locations can be used for aging. Always take multiple scales from each animal, and place in a single age structure envelope.

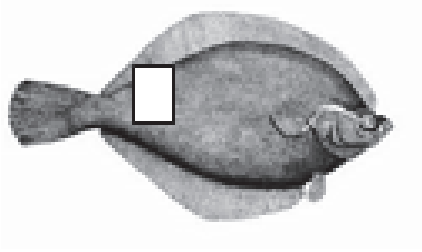

Figure 79. Location to take scales from yellowtail flounder.

To sample monkfish, lift the first fin ray (illicium) and use tweezers to grab at the bulb of the base. Then cut below the tweezers, being sure to include the base in your sample. The entire illicium, including the esca (the “fishing lure” at the end), should be put in a Ziplock bag with a fully completed tag and frozen. If the illicium is missing or broken, sample the second fin ray instead. (method from Duarte 1997)

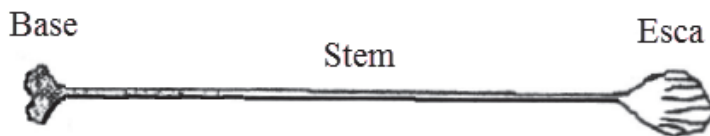

Figure 80. Parts of the monkfish illicium.

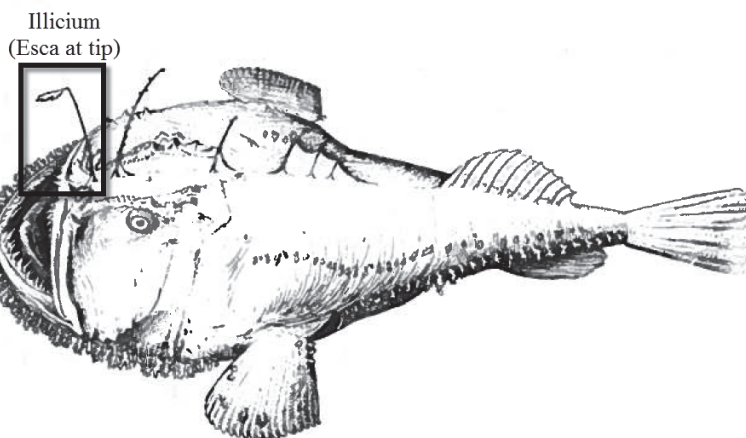

Figure 81. Location of the monkfish illicium.

Submitting Scales and Otoliths

NOAA/NMFS FISHERIES OBSERVER PROGRAM			
Obs./Trip ID	A03099-		
Haul #	15		
Haul Date	05 / 11 / 13		
Statistical Area	539		
Species	Yellowtail Flounder		
Length	32 cm		
Disposition		Sex	
Discarded	0 12	Unknown	0
Kept	1	Male	1
Transferred	2	Female	2 X

Figure 82. Age structure envelope used for collecting scale and otolith samples.

Place samples from a single animal in an age structure envelope (see Figure 82) with a liner (a short piece of paper folded in half). If collecting otoliths, be careful not to crush them.

Group sample envelopes from each haul, species, and disposition code, and rubber band them together. The first envelope ("header") should be completely filled out, in pencil. After the header envelope, only the length needs to be filled out.

Thoroughly dry all envelopes before bagging for shipment. Keep all scales and otoliths at room temperature; do not freeze. Place the bundles of envelopes inside a plastic bag, and submit them with your trip paperwork.

Submitting Frozen Samples

Some sample types must be frozen before shipment. These include monkfish illicium, heads taken in lieu of otoliths, and DNA samples.

Place each sample in a separate Ziploc bag with a fully completed Tyvek tag (see Figure 83). Tags must always be filled out front and back using a fine-point permanent marker. Arrange the tag so that it can be read from the outside of the bag. For marine mammal tissue samples, place this bag inside a second Ziploc bag with a second fully completed Tyvek tag ("double bag, double tag").

Group age samples from a single haul and disposition together, and place them in a larger Ziploc bag. Freeze solid before placing in cooler, and use sufficient ice packs (at least 2) and crumpled newspaper.

Submitting Large Samples

If an entire marine mammal is retained, a biological sample tag should be completed and attached to the animal's lower jaw or caudal peduncle, in addition to the yellow carcass tag.

If an entire turtle is retained, a biological sample tag should be completed and attached to the animal's flipper, in addition to tagging the rear flipper with one Inconel tag.

All protected species samples must be double bagged and double tagged.

NMFS FISHERIES OBSERVER PROGRAM

TripID _____ Land mm/yy _____ Gear Code _____

Species _____ PSID/Seq# _____

Haul# _____ Haul Date mm/dd/yy _____ Stat Area _____

Tag# _____ Length _____ Disp _____

SAMPLE CATEGORY (check all that apply):

SPEC. VERIF. PROG. AGE STRUCTURE TRAINING
 INC. TAKE SPECIAL PROGRAM

SPECIAL PROGRAM: _____ OTHER: _____

SAMPLE TYPE:

WHOLE <input type="checkbox"/>	FEATHER <input type="checkbox"/>	KIDNEY <input type="checkbox"/>	DNA: FIN CLIP <input type="checkbox"/> FLIPPER <input type="checkbox"/> BIOPSY <input type="checkbox"/> SKIN <input type="checkbox"/>
HEAD <input type="checkbox"/>	WHISKER <input type="checkbox"/>	LIVER <input type="checkbox"/>	
JAW <input type="checkbox"/>	BLUBBER <input type="checkbox"/>	MUSCLE <input type="checkbox"/>	
VERTEBRA <input type="checkbox"/>	STOMACH <input type="checkbox"/>	REP. ORG. <input type="checkbox"/>	
ILLCIUM <input type="checkbox"/>	HEART <input type="checkbox"/>	FETUS <input type="checkbox"/>	
OTHER: _____			

Figure 83. Tyvek tags.

Scallop Sampling

When observing scallop dredge and scallop trawl trips, you will be collecting additional catch information that is used to look at correlations between dressed and round scallops. This additional information includes scallop shell height frequencies, scallop meat weights, and volumetric measurements of scallop meats. For more detailed information on scallop sampling, including how often sampling should occur, refer to the [FSB Observer On-Deck Reference Guide](#).

To obtain scallop shell heights, first insert the waterproof Shellfish Tally Sheet into the Shellfish Length Frequency Board. Place a scallop on the board, with the flat side on the board and the hinge of the shell against the bottom of the board. Slide the scallop along the board, until the top edge of the shell fits into one of the indicated ranges to mark the height measurement of the shell. Place a tally mark in the box for that range (see Figure 84).



Figure 84. Examples of how to measure scallop shell height.

To obtain a scallop meat weight, ask the captain or crew to dress (shuck) the scallops that you have measured. These scallops should be dressed into a separate bucket and returned to you for weighing. Drain as much excess liquid as possible without damaging the meats, and weigh the scallop meats to the tenths place. It is important to remember that only the captain or crew should be shucking scallops, in order to provide end users with the most accurate representation of what the dressed meat weights are in relation to the round weights.

To obtain a volumetric measurement, measure the dressed meats (that you obtained a weight for) in your issued plastic volumetric cup. Record the volume to the nearest 50 mL increment (see Figure 85).



Figure 85. An example of obtaining a scallop meat weight volumetric measure.

Clam/Quahog Sampling

To obtain clam/quahog shell widths, first insert the waterproof Shellfish Tally Sheet into the Shellfish Length Frequency Board. Place a clam/quahog on the board, with the hinge side of the shell on the left side of the board and the side of shell against the bottom of the board. Slide the clam/quahog along the board until the top edge of the shell fits into one of the indicated ranges to mark the widest measurement of the shell. Place a tally mark in the box for that range (see Figure 86).



Figure 86. An example of how to measure clam/quahog shell width.

Whelk Sampling

Place whelk into the Whelk Sampling board so that one edge rests on the outer edge. Adjust the moveable piece of the board until it rests against the other edge of the shell. Avoid twisting or moving the shell while obtaining the width measurement (see Figure 87).



Figure 87. An example of how to obtain width measurements using the Whelk Sampling board.

Crustacean Sampling

On some trips, you may be sampling crustaceans. This is usually done on deployments where lobsters or crabs are being targeted, but it can also be done on other deployments, as the biological sampling priorities specify, and as time permits. This sampling will include carapace measurements, sex of each individual, presence of eggs and stage, presence of V-notch and type, molt stage, number of claws present, and presence of shell disease. Hauls where lobsters are sampled must also be observed.

Carapace Measuring

For lobsters, measure the length of the carapace in whole millimeters (from the back of the eye socket to where carapace ends at the base of the abdomen, see Figure 88). For crabs, measure the width of the carapace in whole millimeters (across the widest part of the carapace, see Figure 89). These measurements should be taken using the large jaws of your Vernier calipers.

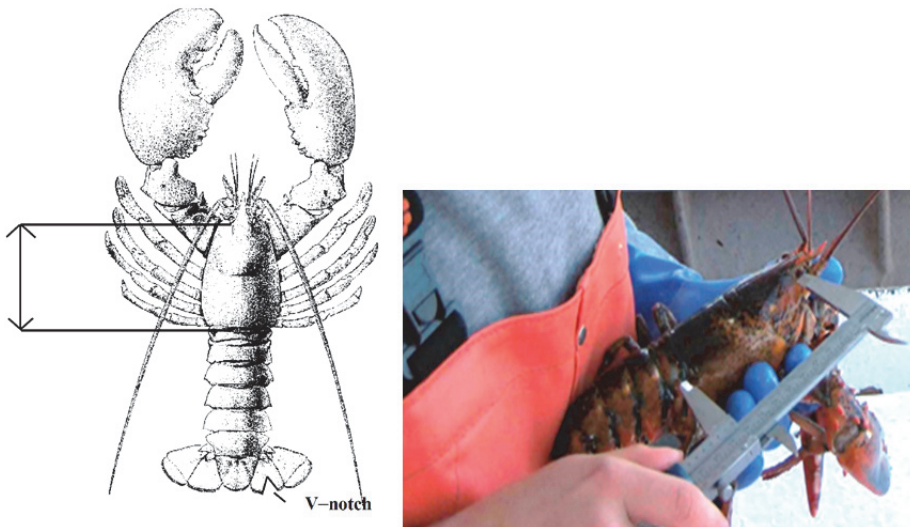

Figure 88. Taking carapace length for lobsters.

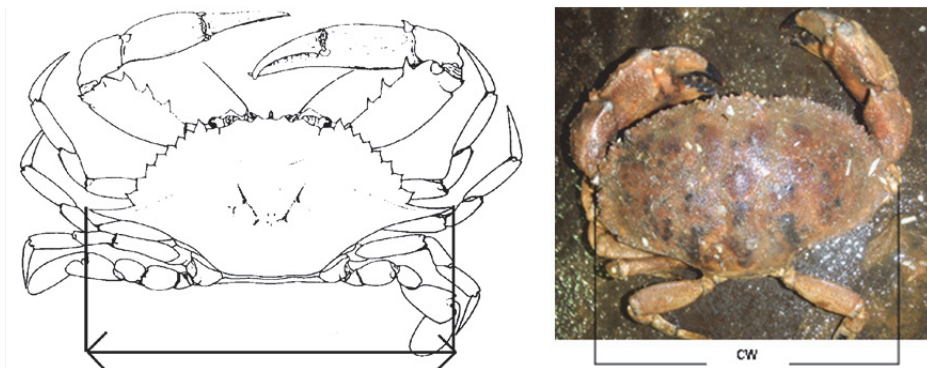

Figure 89. Measuring the carapace width of a crab.

Sex

This will differ between crabs and lobsters. While sampling crabs, look at the shape of the apron, located on the abdomen. The apron will be tall and narrow on males, and much wider on females (to accommodate the presence of eggs) (see Figure 90). While sampling lobsters, look at the first pair of swimmerets, located directly below the walking legs. The first pair of swimmerets will be hard and rigid in a male lobster, and flexible and feathery in a female lobster (see Figure 91).

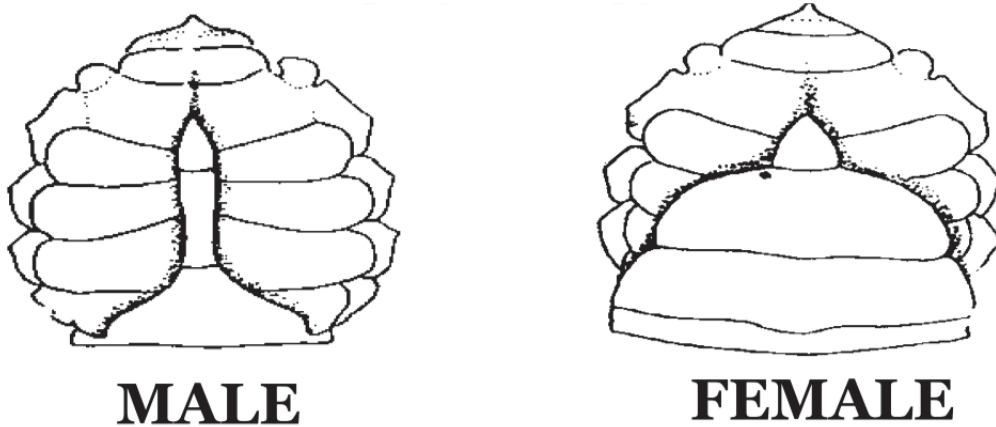

Figure 90. Difference in the apron shape of male and female crabs.

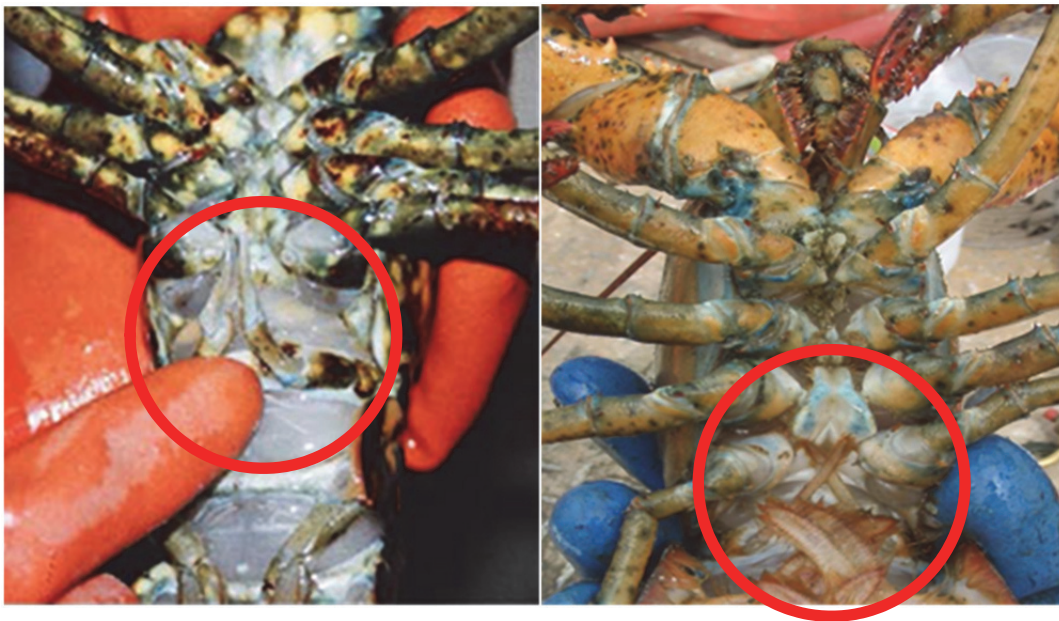

Figure 91. First set of swimmerets in a male (left) and female (right) lobster.

Eggs

To determine whether a crustacean has eggs or not, look at the underside of the body. Crab eggs are orange to black and carried under the apron (see Figure 92).



Figure 92. Female crab with eggs.

Lobster eggs are light green to black and carried on the underside of the tail (see Figure 93).



Figure 93. Female lobster with eggs.

There are 5 stages of lobster egg development:

Newly extruded

Eggs are generally uniform in color and no eye spots are visible.



Figure 94. Newly extruded lobster eggs.

Eyed eggs

At first, eye spots will be just barely visible as small black specks. This can be very difficult to distinguish from newly extruded eggs. As they mature, the eye spots turn turquoise in color and the eggs will have a dark green/purple appearance. When they are almost ready to hatch, eggs will be a reddish/brown color and have turquoise eyes.



Figure 95. Eyed lobster eggs.

Hatching eggs

When the eggs have started to hatch, they will take on a blue appearance, with brownish fuzz. When the eggs are almost spent, there will be fewer eggs on the abdomen. The eggs will be bluish in color and fibrous material will be present.

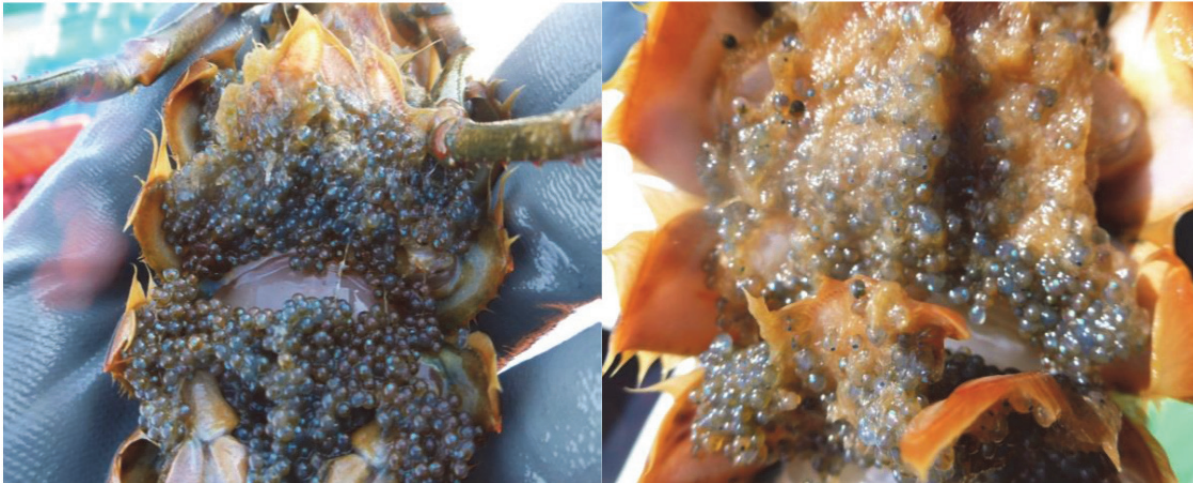

Figure 96. Hatching lobster eggs.

Spent

When the eggs are spent, there will be a furry appearance of the setae on the underside of the lobster, caused by cementum, a sticky substance that holds the eggs to the lobster's abdomen.



Figure 97. Lobster eggs spent.

Shell Disease

Shell disease is an infection of the lobster carapace, which causes dark necrotic spots or lesions. Check all lobsters¹³ for shell disease. Look for rust-colored spotting spread over the carapace (see Figure 98). Take photos and document the individual(s) exhibiting shell disease, when possible.

¹³ You may also encounter crabs with shell disease. If so, take photographs and record comments about the number of animals affected.



Figure 98. Examples of lobsters with shell disease.

V-Notch

A v-notch is a triangular, 1/8"-1/4" deep cut in the tail of a lobster. It is usually on the lobster's right-hand side (on the second telson from the edge of the tail), and may last for 2-3 molts. The marking identifies a breeding female, and is intended to protect her from being harvested through additional molts (see Figure 99). You should verify with the captain/crew if a v-notch is present (or if it is some type of natural mutilation).

V-notches should be classified as old or new (see Figure 100). Old v-notches will have uneven edges, possible infected areas, and smooth shell. New v-notches will have clean edges with a distinctive V shape and a cracked shell with a thin black line of scar tissue along the edge of the wound.

Other manmade mutilations can be considered v-notches, such as:

- Up to 50% of the flipper cut off horizontally or obliquely with a knife
- Complete removal of the flipper

Natural mutilations can be difficult to distinguish from v-notches. The wounds may not be straight edged, appearing jagged or irregular. They may also appear as a small nick or indentation on the side or edge of the flipper, or may extend to adjoining flippers. When uncertain, ask the captain.

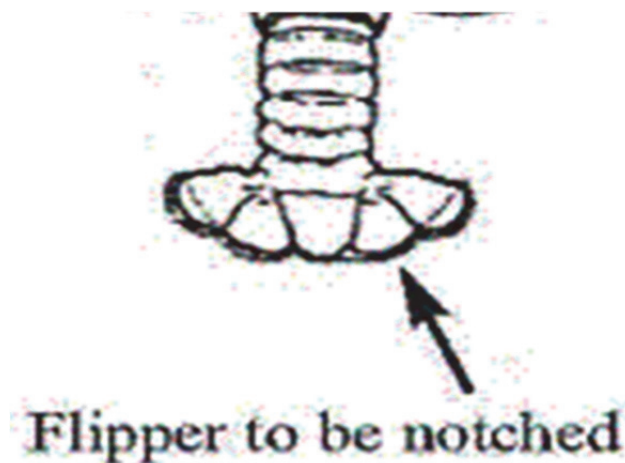

Figure 99. Drawing showing which telson on a female lobster should be v-notched.

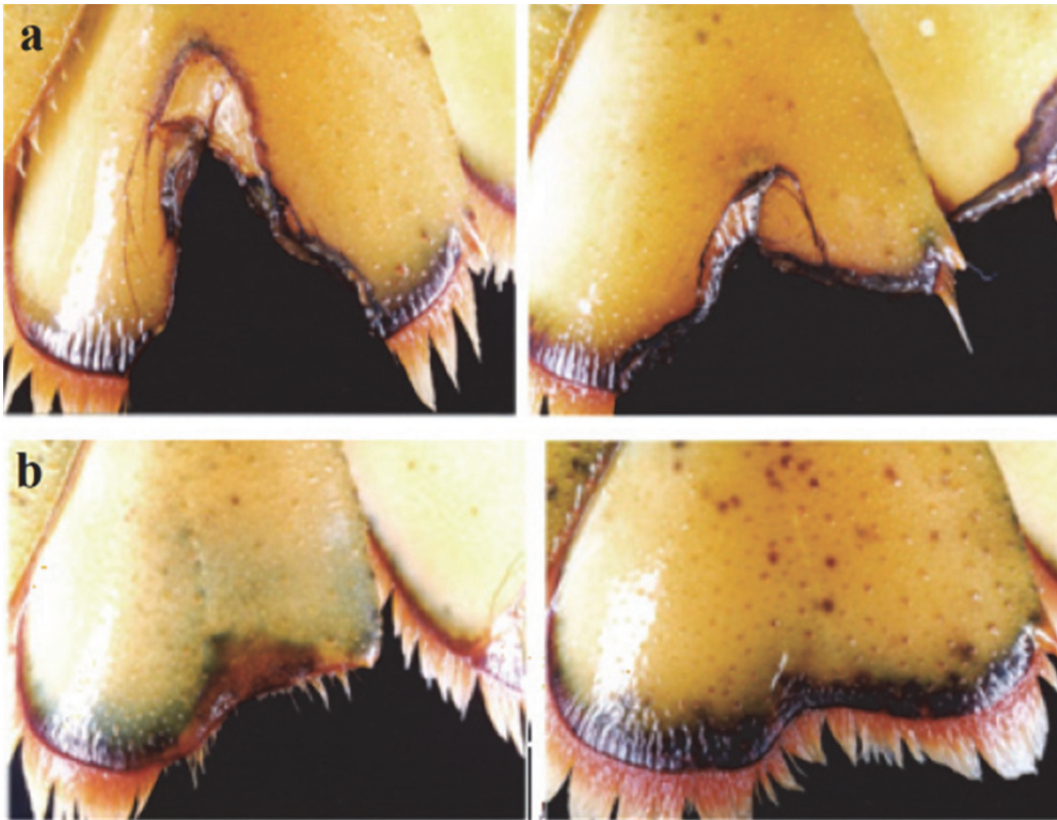

Figure 100. Examples of new (a) and old (b) v-notches.

Molt Stage

Since their shells are hard and inelastic, crustaceans need to shed their old shell (molt) periodically, in order to continue growing. To determine the molt stage of lobsters, use these guidelines (in reference to how the carapace feels when pressure is applied to it) (see Figure 101):

Soft: The lobster feels gelatinous. Barely a shell, very fragile; does not spring back after applying lateral pressure.

Paper: The lobster has the beginnings of a hard shell, but the shell crinkles like a soda can when pressed.

Hard: The lobster has a hard shell and will feel rigid; withstands lateral pressure.

Splitter: The lobster has a hard shell, with a splitting line going down the center of its body (in preparation to molt).



Figure 101. Examples of lobster molt stage . Top left = soft. Top right = paper. Bottom left = hard. Bottom right = splitter.

Number of Claws

Count how many front claws are present on the lobster being sampled. To be counted, claws must have a shell, regardless of size or shell condition. Do not count regenerating claws, which are small, fleshy appendages with no shell (see Figure 102).



Figure 102. Lobster with regenerating claws that should not be included in the count of number of claws present.

Notes

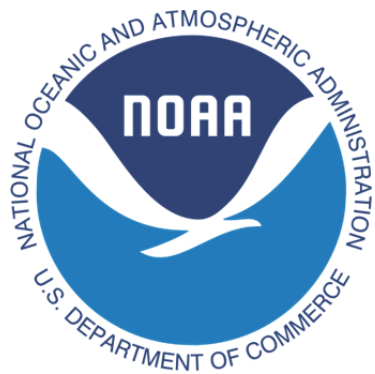

Revised 05/01/2016