

**NATIONAL MARINE FISHERIES SERVICE  
ENDANGERED SPECIES ACT SECTION 7  
BIOLOGICAL OPINION**

**Title:** Biological Opinion and Conference for the Construction, Operation, Maintenance, and Decommissioning of the Coastal Virginia Offshore Wind Commercial Project (Lease OCS-A 0483)

**Consultation Conducted By:** Endangered Species Act (ESA) Interagency Cooperation Division, Office of Protected Resources, National Marine Fisheries Service, National Oceanic and Atmospheric Administration, U.S. Department of Commerce

**Action Agencies:** Bureau of Ocean Energy Management  
Bureau of Safety and Environmental Enforcement  
National Marine Fisheries Service, Office of Protected Resources  
U.S. Army Corps of Engineers  
U.S. Coast Guard  
U.S. Environmental Protection Agency

**Publisher:** Office of Protected Resources, National Marine Fisheries Service, National Oceanic and Atmospheric Administration, U.S. Department of Commerce

**Approved:** DAMON  
RANDALL.KIMBERLY.BETH.13658  
21093

Digitally signed by DAMON  
RANDALL.KIMBERLY.BETH.1365821093  
Date: 2023.09.18 11:01:43 -04'00'

---

Kim Damon-Randall  
Director, Office of Protected Resources

**Date:** September 18, 2023

**Consultation Tracking Number:** OPR-2023-02218

**TABLE OF CONTENTS**

**1 Introduction..... 9**

    1.1 *Regulatory Authorities* ..... 9

**2 Consultation History And Approach To The Assessment ..... 12**

**3 Description Of The Proposed Actions On Which Consultation Was Requested..... 13**

    3.1 *Overview of Proposed Federal Actions* ..... 13

    3.2 *Construction*..... 15

        3.2.1 *Seafloor Clearance* ..... 17

        3.2.2 *Foundations, Wind Turbine Generators (WTG) and Offshore Substations (OSS)* .. 18

        3.2.3 *Cable Installation* ..... 24

        3.2.4 *Cable Landfall Connection* ..... 25

        3.2.5 *Vessels* ..... 26

    3.3 *Operations and Maintenance (O&M)*..... 30

        3.3.1 *Vessel Operations* ..... 33

    3.4 *Decommissioning*..... 33

    3.5 *High-Resolution Geophysical (HRG) Surveys*..... 35

    3.6 *Fisheries Monitoring Plans* ..... 37

        3.6.1 *Whelk Surveys* ..... 38

        3.6.2 *Black Sea Bass Surveys* ..... 39

    3.7 *Minimization and Monitoring Measures that are part of the Proposed Action* ..... 40

    3.8 *MMPA Incidental Take Authorization (ITA) Proposed for Issuance by NMFS*..... 42

        3.8.1 *Amount of Take Proposed for Authorization* ..... 43

        3.8.2 *Mitigation Measures Included in the Proposed ITA*..... 44

    3.9 *Action Area* ..... 45

**4 Species and Critical Habitat Not Likely to be Adversely Affected ..... 45**

    4.1 *Blue Whale (Balaenoptera musculus)*..... 46

    4.2 *Rice’s Whale (Balaenoptera ricei)*..... 47

    4.3 *Atlantic Salmon (Salmo salar) - Gulf of Maine DPS*..... 48

    4.4 *Oceanic Whitetip Shark (Carcharhinus longimanus)*..... 48

    4.5 *Scalloped Hammerhead Shark (Sphyrna lewini)* ..... 49

    4.6 *Shortnose Sturgeon (Acipenser brevirostrum)*..... 49

    4.7 *Gulf Sturgeon (Acipenser oxyrinchus desotoi)* ..... 50

    4.8 *Hawksbill Sea Turtle (Eretmochelys imbricata)*..... 50

    4.9 *Giant Manta Ray (Manta birostris)* ..... 51

4.10	<i>North Atlantic Right Whale Critical Habitat</i> .....	52
4.11	<i>Atlantic Sturgeon Critical Habitat for All Listed Distinct Population Segments</i> .....	53
4.12	<i>Critical Habitat in the Gulf of Mexico</i> .....	53
<b>5</b>	<b>Status of the Species Likely to be Adversely Affected</b> .....	<b>54</b>
5.1	<i>Fin Whale (Balaenoptera physalus)</i> .....	54
5.1.1	Life History.....	55
5.1.2	Population Dynamics .....	55
5.1.3	Status.....	57
5.1.4	Critical Habitat.....	57
5.1.5	Recovery Goals.....	57
5.2	<i>North Atlantic Right Whale (Eubalaena glacialis)</i> .....	58
5.2.1	Life History.....	59
5.2.2	Population Dynamics .....	60
5.2.3	Status.....	62
5.2.4	Factors Outside the Action Area Affecting the Status of the Right Whale: Fishery Interactions and Vessel Strikes in Canadian Waters.....	64
5.2.5	Critical Habitat.....	68
5.2.6	Recovery Goals.....	68
5.3	<i>Sei Whale (Balaenoptera borealis)</i> .....	69
5.3.1	Life History.....	70
5.3.2	Population Dynamics .....	70
5.3.3	Status.....	71
5.3.4	Critical Habitat.....	71
5.3.5	Recovery Goals.....	71
5.4	<i>Sperm Whale (Physeter macrocephalus)</i> .....	72
5.4.1	Life History.....	73
5.4.2	Population Dynamics .....	73
5.4.3	Status.....	74
5.4.4	Critical Habitat.....	74
5.4.5	Recovery Goals.....	74
5.5	<i>Green Sea Turtle (Chelonia mydas, North Atlantic DPS)</i> .....	74
5.5.1	Life History.....	76
5.5.2	Population Dynamics .....	76
5.5.3	Status.....	78
5.5.4	Critical Habitat.....	78
5.5.5	Recovery Goals.....	79
5.6	<i>Leatherback Sea Turtle (Deromchelys coriacea)</i> .....	79
5.6.1	Life History.....	80
5.6.2	Population Dynamics .....	82
5.6.3	Status.....	85
5.6.4	Critical Habitat.....	85
5.6.5	Recovery Goals.....	85

5.7 *Loggerhead Sea Turtle (Caretta caretta, Northwest Atlantic Ocean DPS)*..... 86

    5.7.1 Life History..... 87

    5.7.2 Population Dynamics..... 89

    5.7.3 Status..... 92

    5.7.4 Critical Habitat..... 93

    5.7.5 Recovery Goals..... 94

5.8 *Kemp’s Ridley Sea Turtle (Lepidochelys kempii)*..... 94

    5.8.1 Life History..... 95

    5.8.2 Population Dynamics..... 96

    5.8.3 Status..... 97

    5.8.4 Critical Habitat..... 98

    5.8.5 Recovery Goals..... 98

5.9 *Atlantic Sturgeon (Acipenser oxyrinchus oxyrinchus)*..... 98

    5.9.1 Life History..... 100

    5.9.2 Population Dynamics..... 102

    5.9.3 Status..... 105

    5.9.4 Critical Habitat..... 106

    5.9.5 DPS Specific Information..... 106

**6 Environmental Baseline..... 115**

    6.1 *Physical Environment*..... 116

    6.2 *Underwater Noise*..... 117

        6.2.1 Vessel Sound..... 118

        6.2.2 Seismic Surveys..... 119

    6.3 *Climate Change*..... 120

    6.4 *Fishing Activity in the Action Area*..... 123

        6.4.1 Fishery Interactions and Entanglement..... 123

        6.4.2 Federally Managed Fisheries..... 125

    6.5 *Vessel Traffic & Interactions*..... 128

        6.5.1 Vessel Traffic in the Lease Area and Surrounding Waters..... 129

        6.5.2 Vessel Impacts to ESA-listed Species..... 131

    6.6 *Military Operations*..... 133

    6.7 *Scientific Research*..... 133

    6.8 *Marine Debris and Pollution*..... 134

    6.9 *Offshore Wind Development*..... 135

        6.9.1 Site Assessment, Site Characterization, and Surveys..... 136

        6.9.2 Consideration of Construction, Operation, and Decommissioning of Other OSW Projects..... 136

**7 Effects of the Action..... 136**

    7.1 *Underwater Noise and Acoustic Thresholds*..... 137

        7.1.1 Whale Acoustic Thresholds..... 138

7.1.2	Sea Turtle Acoustic Thresholds .....	140
7.1.3	Fish Acoustic Thresholds.....	141
7.2	<i>Stressors Not Likely to Adversely Affect</i> .....	141
7.2.1	Goal Post Pile Installation.....	141
7.2.2	Cofferdam Installation .....	144
7.2.3	Controlled Flow Excavation .....	146
7.2.4	HRG Surveys .....	147
7.2.5	Vessel and Cable Installation Noise .....	153
7.2.6	WTG Operational Noise .....	157
7.2.7	Noise Impacts to Prey .....	161
7.2.8	Presence of Physical Structures .....	162
7.2.9	Changes in Oceanographic and Hydrological Conditions .....	166
7.2.10	Water Quality Effects .....	177
7.2.11	Electromagnetic Fields and Heat during Cable Operation .....	182
7.2.12	Fishery Monitoring Surveys .....	186
7.2.13	Potential Shifts in Fisheries .....	186
7.2.14	Project Decommissioning.....	189
7.3	<i>Stressors Likely to Adversely Affect</i> .....	191
7.3.1	Pile driving WTG and OSS Foundations.....	191
7.3.2	Vessel Strike .....	201
7.4	<i>Summary of Adverse Effects</i> .....	211
7.4.1	Pile-Driving.....	211
7.4.2	Vessel Strike .....	211
7.5	<i>Consideration of the Effects of the Action in the Context of Predicted Climate Change</i> 211	
<b>8</b>	<b>Cumulative Effects</b> .....	<b>214</b>
<b>9</b>	<b>Integration and Synthesis</b> .....	<b>215</b>
9.1	<i>North Atlantic Right Whales</i> .....	215
9.2	<i>Fin Whales</i> .....	217
9.3	<i>Sei Whales</i> .....	219
9.4	<i>Sperm Whales</i> .....	220
9.5	<i>Sea turtles</i> .....	222
9.5.1	Loggerhead, Northwest Atlantic Ocean DPS .....	224
9.5.2	Kemp’s Ridley .....	225
9.5.3	Green, North Atlantic DPS .....	226
9.5.4	Leatherback.....	226
9.6	<i>Atlantic sturgeon</i> .....	227
9.6.1	New York Bight DPS.....	228
9.6.2	Chesapeake Bay DPS.....	228
9.6.3	South Atlantic DPS .....	229

9.6.4 Carolina DPS ..... 229

9.6.5 Gulf of Maine DPS ..... 229

**10 Conclusion ..... 230**

**11 Incidental Take Statement ..... 230**

    11.1 Amount or Extent of Take ..... 231

    11.2 Reasonable and Prudent Measures ..... 232

    11.3 Terms and Conditions ..... 232

**12 Conservation Recommendations ..... 246**

**13 Reinitiation Notice ..... 247**

**14 Literature Cited ..... 249**

**15 Appendix A: Proposed mitigation, monitoring, and reporting measures in the BA.. 295**

    15.1 Copy of Table 1-7 in BOEM’s BA: Mitigation, monitoring, and reporting measures committed to by the Applicant..... 295

    15.2 Copy of Table 1-8 in BOEM’s BA: Additional proposed mitigation, monitoring, and reporting measures proposed by BOEM..... 308

**16 Appendix B: Mitigation, Monitoring, and Reporting Measures in the Proposed MMPA Authorization..... 324**

**List of Tables**

**Table 1. Summary of pile strikes, piling progression, and pile strikes for the three WTG foundation installation scenarios..... 19**

**Table 2. Proposed pile-driving installation schedule for CVOW-C Project..... 20**

**Table 3. Pile strikes and progression for the Offshore Substation Foundation Installation..... 23**

**Table 4. Summary of offshore vessels for construction in the Proposed Action ..... 26**

**Table 5. Expected oil/lubricants for WTGs ..... 31**

**Table 6. Expected Oil/Fuel/Lubricants for OSSs..... 32**

**Table 7. Summary of decommissioning methods and assumptions ..... 34**

**Table 8. HRG Acoustic Sources and their Operational Parameters..... 35**

**Table 9. Proposed HRG Survey Schedule for the CVOW-C Project..... 37**

**Table 10. Proposed clearance and exclusion zones. .... 41**

**Table 11. Total Take of ESA-Listed Species by Level A Harassment and Level B Harassment Proposed for Authorization through the MMPA ITA..... 43**

<b>Table 12. Take of ESA-Listed Species by Level A and B Harassment Proposed for Authorization through the MMPA ITA Resulting from Vibratory and Impact Pile Driving of WTG and OSS Foundations</b>	<b>44</b>
<b>Table 13. Take of ESA-Listed Species by Level B Harassment Proposed for Authorization through the MMPA ITA Resulting from HRG Surveys.</b>	<b>44</b>
<b>Table 14. Descriptions of Atlantic sturgeon life history stages</b>	<b>101</b>
<b>Table 15. Calculated population estimates based upon the NEAMAP survey swept area model, assuming 50% efficiency</b>	<b>102</b>
<b>Table 16. Exempted take from other current section 7 fisheries consultations on the U.S. Atlantic coast.</b>	<b>126</b>
<b>Table 17. Estimated average annual turtle interactions in select commercial fishing gears in the Mid-Atlantic and Georges Bank regions. Numbers in parentheses are adult equivalents.</b>	<b>128</b>
<b>Table 18. Onset of PTS and TTS for Low and Mid Frequency Cetaceans from Impulsive Sources.</b>	<b>139</b>
<b>Table 19. Onset of PTS and TTS for Low and Mid Frequency Cetaceans from Non-Impulsive Sources.</b>	<b>139</b>
<b>Table 20. Onset of Behavioral Disturbance for Marine Mammals (70 FR 1871)</b>	<b>140</b>
<b>Table 21. Onset of PTS and TTS for Sea Turtles from Impulsive Sources.</b>	<b>140</b>
<b>Table 22. Onset of PTS and TTS for Sea Turtles from Non-Impulsive Sources.</b>	<b>140</b>
<b>Table 23. Onset of Behavioral Disturbance for Sea Turtles.</b>	<b>140</b>
<b>Table 24. Onset of Physical Injury for Impulsive Sources for Fishes (FHWG 2008)</b>	<b>141</b>
<b>Table 25. Maximum ranges (m) to PTS and behavioral thresholds for cetaceans during impact pile driving of up to 2 goal post piles per day.</b>	<b>142</b>
<b>Table 26. Estimated number of ESA-listed cetaceans exposed to noise above PTS or behavioral thresholds from goal post impact pile driving.</b>	<b>142</b>
<b>Table 27. Maximum ranges (m) to PTS and behavioral thresholds for sea turtles during impact pile driving of up to 2 goal post piles per day.</b>	<b>143</b>
<b>Table 28. Maximum distances (m) to PTS and behavioral thresholds for cetaceans during vibratory pile driving of cofferdams.</b>	<b>144</b>
<b>Table 29. Estimated number of ESA-listed cetaceans exposed to noise above behavioral thresholds from vibratory pile driving of cofferdams.</b>	<b>145</b>
<b>Table 30. Maximum distances (m) to PTS and behavioral thresholds for sea turtles during vibratory pile driving of cofferdams.</b>	<b>146</b>
<b>Table 31. Largest PTS Exposure Distances from mobile HRG Sources at Speeds of 4.5 knots – Fish and Sea Turtles.</b>	<b>148</b>
<b>Table 32. Largest disturbance distances by equipment type – Sea Turtles and Fish</b>	<b>148</b>
<b>Table 33. Summary of Representative HRG Survey Equipment Distances to the Level B Harassment Threshold</b>	<b>149</b>
<b>Table 34. Maximum distances (m) for WTG and OSS foundation installation scenarios with 10 dB noise mitigation to PTS and behavioral thresholds for cetaceans.</b>	<b>192</b>

**Table 35. Mean seasonal density estimates (animals/km<sup>2</sup>) for ESA-listed cetacean species in the project-buffered (8.9 km) lease Area..... 193**

**Table 36. Annual estimated number of ESA-listed cetaceans exposed to PTS and behavioral threshold noise during pile driving installation of WTG and OSS foundations using both impact and vibratory pile driving with 10 dB noise mitigation..... 193**

**Table 37. Maximum distances (m) to sea turtle thresholds for WTG and OSS foundation pile driving scenarios with 10 dB noise mitigation..... 196**

**Table 38. Estimated seasonal densities (animals/km<sup>2</sup>) for sea turtle species occurring in the Project area 197**

**Table 39. Annual estimated number of sea turtles exposed to PTS or behavioral-level noise from WTG and OSS foundation pile-driving with 10-dB noise mitigation. .... 197**

**Table 40. Maximum modeled distances (m) to physical injury and behavioral thresholds to fish (≥2 g) from impact and vibratory pile driving during installation of the WTG and OSS foundations with 10 dB noise mitigation..... 201**

**Table 41. Records of sea turtles with vessel strike and blunt force trauma injuries from 2013 to 2020 in Virginia..... 206**

**Table 42. Sea turtles vessel strike mortalities from 2013 to 2020 in Virginia, corrected for estimate of unobserved cases..... 207**

**Table 43. Annual project vessel transits and percent increase in Chesapeake Bay entrance transits. 207**

**Table 44. Estimates of sea turtles impacted by vessel strike..... 208**

**Table 45. Reports of dead Atlantic sturgeon attributed to vessel strike in the Chesapeake Bay, VA. 209**

**Table 46. Estimates of Atlantic sturgeon impacted by vessel strike..... 210**

**Table 47. Vessel strike estimates apportioned to Atlantic sturgeon DPSs..... 211**

**Table 48. Clearance and Shutdown Zones for ESA-listed Species..... 245**

**List of Figures**

**Figure 1. CVOW-C lease development area and export cable corridor..... 14**

**Figure 2. Conceptual Project Schematic..... 15**

**Figure 3. Proposed Construction Schedule..... 16**

**Figure 4. Schematic of installed foundation and assembled WTG..... 21**

**Figure 5. CVOW-C WTG and offshore substation layout..... 22**

**Figure 6. Scaled representation of CVOW-C’s proposed Offshore Project components and common vessel types relative to WTG rotor diameter and 0.75 nautical mile turbine spacing..... 23**

**Figure 7. Representative turbine and cable array in A. Example of depth stratified subareas for fishery pot survey sites in B..... 39**

**Figure 8. Range of the fin whale ..... 55**

**Figure 9. Approximate historic range and currently designated U.S. critical habitat of the NARW58**



**Figure 10. Lobster fishing areas in Atlantic Canada** (<https://www.dfo-mpo.gc.ca/fisheries-peches/commercial-commerciale/atl-arc/lobster-homard-eng.html>) ..... 66

**Figure 11. Range of the sei whale** ..... 70

**Figure 12. Range of the sperm whale** ..... 72

**Figure 13. Geographic range of the North Atlantic DPS of green turtles, with location and abundance of nesting females (Seminoff et al. 2015a)** ..... 76

**Figure 14. Number of green sea turtle nests counted on core index beaches in Florida from 1989-2021** (<https://myfwc.com/research/wildlife/sea-turtles/nesting/beach-survey-totals/>) ..... 78

**Figure 15. Range of endangered leatherback turtle; adapted from Wallace et al. 2013** ..... 80

**Figure 16. Number of leatherback sea turtle nests on core index beaches in Florida from 1989-2021** (<https://myfwc.com/research/wildlife/sea-turtles/nesting/>)..... 84

**Figure 17. Range of the Northwest Atlantic Ocean DPS loggerhead sea turtles**..... 87

**Figure 18. Annual nest counts of loggerhead sea turtles on Florida core index beaches in peninsular Florida, 1989-2021** (<https://myfwc.com/research/wildlife/sea-turtles/nesting/beach-survey-totals/>) 90

**Figure 19. Annual nest counts of loggerhead sea turtles on index beaches in the Florida Panhandle, 1997-2021** (<https://myfwc.com/research/wildlife/sea-turtles/nesting/beach-survey-totals/>)..... 91

**Figure 20. Map identifying designated critical habitat for the Northwest Atlantic Ocean DPS of loggerhead turtle** ..... 93

**Figure 21. Kemp’s ridley sea turtle geographic range**..... 95

**Figure 22. Kemp's ridley nest totals from Mexican beaches (Gladys Porter Zoo nesting database 2019)** 97

**Figure 23. U.S. range of Atlantic sturgeon DPSs** ..... 99

**Figure 24. Chesapeake Bay port vessel traffic in calendar year 2019 from the** ..... 129

## 1 INTRODUCTION

This constitutes NOAA's National Marine Fisheries Service's (NMFS) biological opinion and conference (Opinion) issued to the Bureau of Ocean Energy Management (BOEM), as the lead Federal agency, in accordance with section 7 of the Endangered Species Act of 1973 (ESA), as amended, on the effects of its approval with conditions of the Construction and Operations Plan (COP) authorizing the construction, operation, maintenance, and decommissioning of the Coastal Virginia Offshore Wind Commercial (CVOW-C) Project under the Outer Continental Shelf Lands Act (OCSLA). The applicant, the Virginia Electric and Power Company, doing business as Dominion Energy Virginia (Dominion Energy) is proposing to construct, operate, and eventually decommission a commercial-scale offshore wind energy facility within Lease Area OCS-A 0483 that would consist of 176 wind turbine generators (WTG), three offshore substations, and associated inter-array cabling as well as export cabling to bring electricity to land.

BOEM is the lead Federal agency for purposes of section 7 consultation; the other action agencies for the Project's components include the Bureau of Safety and Environmental Enforcement (BSEE), the U.S. Army Corps of Engineers (USACE), the U.S. Coast Guard (USCG), the U.S. Environmental Protection Agency (EPA), and NMFS Office of Protected Resources (OPR)<sup>1</sup> each of whom is taking action under their respective statutory and regulatory authorities related to approval of the COP and its conditions and therefore have corresponding ESA section 7 consultation responsibilities. This Opinion considers effects of the proposed Federal actions (collectively referred to in this Opinion as the proposed action) on ESA-listed whales, sea turtles, fish, and designated and proposed critical habitat that occur in the action area (as defined in Section 3.9 of this Opinion). A complete administrative record of this consultation will be kept on file at our Greater Atlantic Regional Fisheries Office.

### 1.1 Regulatory Authorities

The Energy Policy Act of 2005 (EPAAct), Public Law 109-58, added section 8(p)(1)(c) to the Outer Continental Shelf Lands Act. The EPAAct authorized the Secretary of Interior to issue leases, easements, and rights-of-way (ROW) on the Outer Continental Shelf (OCS) for renewable energy development, including wind energy. The Secretary delegated this authority to the former Minerals Management Service, and later to BOEM. Final regulations implementing this authority (30 CFR part 585) were promulgated on April 22, 2009 and amended in 2023. These regulations prescribe BOEM's responsibility for determining whether to approve, approve with modifications, or disapprove CVOW-C's COP. CVOW-C filed their COP with BOEM on December 17, 2020, with subsequent updates in June 17, 2021, October 30, 2021, December 3, 2021, May 6, 2022, February 28, 2023, and July 31, 2023<sup>2</sup>. BOEM issued a Notice of Intent to prepare an Environmental Impact Statement (EIS) under the National Environmental Policy Act

---

<sup>1</sup> The NMFS Office of Protected Resources Permits and Conservation Division is proposing to issue an Incidental Take Authorization under the MMPA and is thus an action agency responsible for consulting under Section 7 of the ESA, whereas NMFS Office of Protected Resources Interagency Cooperation Division is the consulting agency, under ESA regulations at 50 C.F.R. part 402.

<sup>2</sup> The COP and appendices are available online at: <https://www.boem.gov/renewable-energy/state-activities/coastal-virginia-offshore-wind-project-construction-and>  
Last accessed July 17, 2023.

(NEPA) (42 USC § 4321 et seq.) on July 2, 2021, to assess the potential biological and physical environmental impacts of the Proposed Action and Alternatives (86 FR 35329). A draft EIS (DEIS) was published on December 16, 2022.<sup>3</sup>

BSEE's mission is to enforce safety, environmental, and conservation compliance with any associated legal and regulatory requirements during project construction and future operations. BSEE will be in charge of the review of Facility Design and Fabrication and Installation Reports, oversee inspections/enforcement actions as appropriate, oversee closeout verification efforts, oversee facility removal inspections/monitoring, and oversee bottom clearance confirmation. BSEE's approvals and activities are included as elements of the proposed action in this Opinion.

USACE issued a Public Notice (NAE-2013-00418)<sup>4</sup> describing its consideration of CVOW-C's request for a permit pursuant to Section 10 of the Rivers and Harbors Act of 1899 (33 U.S.C. 403) and Section 404 of the Clean Water Act (33 U.S.C. 1344) on September 15, 2022. In the USACE notice, the applicant's proposal includes 176 WTGs and three offshore substations (OSSs) connected by a network of inter-array cables. Offshore export cables will extend from the lease area to an onshore cable landing area. USACE's permit is included as an element of the proposed action in this Opinion.

EPA is proposing to issue an OCS Air Permit to CVOW-C. Dominion Energy submitted an application on March 15, 2022 and the permit application was deemed complete on February 7, 2023. As of August 2023, no draft permit has been issued for public comment. This permit will be issued pursuant to the provisions of Section 328 of the Clean Air Act (CAA) and the Code of Federal Regulations (C.F.R.) Title 40, Part 55, and will be effective until surrendered. EPA anticipates including emission limits, operating requirements and work practices, and testing, recordkeeping, and reporting requirements. Anticipated air emission sources are the marine vessels to be used to support construction and operation/maintenance, and any generators or other emission sources at the WTGs and offshore substation. EPA's OCS Air permit is included as an element of the proposed action in this Opinion.

The USCG administers the permits for private aids to navigation (PATON) located on structures positioned in or near navigable waters of the United States. PATONS and Federal aids to navigation (ATONS), including radar transponders, lights, sound signals, buoys, and lighthouses are located throughout the Project area. It is anticipated that USCG approval of additional PATONs during construction of the WTGs, OSS, and along the offshore export cable corridor may be required. These aids serve as a visual reference to support safe maritime navigation. Federal regulations governing PATON are found within 33 CFR part 66 and address the basic requirements and responsibilities. USCG's proposal to permit installation of additional aids to navigation are included as elements of the proposed action in this Opinion.

---

<sup>3</sup> The DEIS is available online at: <https://www.boem.gov/renewable-energy/state-activities/coastal-virginia-offshore-wind-commercial-cvow-c-draft>

Last accessed July 17, 2023.

<sup>4</sup>Public Notice is online at <https://www.nao.usace.army.mil/Media/Public-Notices/Article/3247305/nao-2013-00418-cvow/>

Last accessed July 17, 2023.

The Marine Mammal Protection Act of 1972 (MMPA) as amended, and its implementing regulations (50 CFR part 216) allow, upon request, the incidental take of small numbers of marine mammals by U.S. citizens who engage in a specified activity (other than commercial fishing) within a specified geographic region assuming certain statutory and regulatory findings are made. To “take” is defined under the MMPA (50 CFR § 216.3) as,

to harass, hunt, capture, collect, or kill, or attempt to harass, hunt, capture, collect, or kill any marine mammal. This includes, without limitation, any of the following: The collection of dead animals, or parts thereof; the restraint or detention of a marine mammal, no matter how temporary; tagging a marine mammal; the negligent or intentional operation of an aircraft or vessel, or the doing of any other negligent or intentional act which results in disturbing or molesting a marine mammal; and feeding or attempting to feed a marine mammal in the wild.

“Incidental taking” means “an accidental taking. This does not mean that the taking is unexpected, but rather it includes those takings that are infrequent, unavoidable, or accidental.” (50 C.F.R. §216.103). NMFS OPR has received a request for Incidental Take Regulations (ITR) and associated Letter of Authorization (LOA) from Dominion Energy for the incidental take of marine mammals during the construction of the CVOW-C project.<sup>5</sup>The requested ITR would govern the authorization of take, by both Level A and Level B harassment<sup>6</sup>, but no mortality or serious injury of marine mammals over a 5-year period incidental to construction-related pile driving activities (impact and vibratory) and high-resolution geophysical (HRG) site characterization surveys. A final ITR would allow for the issuance of a Letter of Authorization (LOA) to CVOW-C for a 5-year period.

The CVOW-C project obtained a Letter of Acknowledgment from NMFS for their 2023 black sea bass surveys and expects to obtain an additional Letter of Acknowledgment for the proposed whelk survey activities. A Letter of Acknowledgment acknowledges, but does not authorize, certain activities as scientific research conducted from a scientific research vessel. (See 50 CFR §600.745(a)). Scientific research activities are activities that would meet the definition of fishing under the Magnuson-Stevens Fishery Conservation and Management Act (Magnuson-Stevens Act), but for the statutory exemption provided for scientific research. (16 USC § 1802(16)). Such activities are statutorily exempt from any and all regulations promulgated under the Magnuson-Stevens Act, provided they continue to meet the definition of scientific research activities conducted from a scientific research vessel. To meet the definition of a scientific research vessel, the vessel must be conducting a scientific research activity and be under the direction of one of the following: Foreign government agency; U.S. Government agency; U.S. state or territorial agency; University (or other educational institution accredited by a recognized national or international accreditation body); International treaty organization; or, Scientific institution. In order to meet this definition, vessel activity must be dedicated to the scientific research activity, and cannot include commercial fishing. Scientific research activity includes, but is not limited to,

---

<sup>5</sup> Application, Notice of Receipt of Application, Proposed Rule, and Supporting Materials are available online at: <https://www.fisheries.noaa.gov/action/incidental-take-authorization-dominion-energy-virginia-construction-coastal-virginia> ; Last accessed July 17, 2023

<sup>6</sup> Level A harassment means any act of pursuit, torment, or annoyance that has the potential to injure a marine mammal or marine mammal stock in the wild. Level B harassment refers to acts that have the potential to disturb (but not injure) a marine mammal or marine mammal stock in the wild by disrupting behavioral patterns, including, but not limited to, migration, breathing, nursing, breeding, feeding, or sheltering.

sampling, collecting, observing, or surveying the fish or fishery resources within the Exclusive Economic Zone. Research topics include taxonomy, biology, physiology, behavior, disease, aging, growth, mortality, migration, recruitment, distribution, abundance, ecology, stock structure, bycatch or other collateral effects of fishing, conservation engineering, and catch estimation of fish species considered to be a component of the fishery resources. The issuance of a Magnuson-Stevens Act related Letter of Acknowledgment by NMFS is not a Federal action subject to section 7 consultation, and it is not an authorization or permit to carry out an activity. However, as BOEM's action we are consulting on includes some surveys that may be carried out with a Magnuson-Stevens Act Letter of Acknowledgement, and these surveys' effects would not occur but for the CVOW-C project, it is appropriate to consider them in this Opinion and, to the extent the surveys cause incidental take, in this Opinion's Incidental Take Statement.

## **2 CONSULTATION HISTORY AND APPROACH TO THE ASSESSMENT**

As the lead Federal action agency, and on behalf of BSEE, USACE, EPA, and the USCG, BOEM submitted a request for this ESA section 7 formal consultation with a draft Biological Assessment (BA) on February 3, 2023. We requested additional information from BOEM that was necessary to initiate the consultation in correspondence dated March 2, 2023. On March 23, 2023, we received a revised BA from BOEM. On April 4, 2023, we received a request for ESA section 7 consultation from NMFS OPR and a draft *Notice of Proposed Incidental Take Regulations for the Taking of Marine Mammals Incidental to the Coastal Virginia Offshore Wind Commercial Project*. Formal consultation was initiated on April 4, 2023. Prior to receiving BOEM's request for initiation of consultation, we provided technical assistance to BOEM including review of a preliminary draft BA submitted to us on September 19, 2022; those comments were submitted to BOEM on November 22, 2022. After formal consultation was initiated, we submitted questions to BOEM on July 17, 2023 to help clarify the proposed activities and they provided a BA Addendum on August 3, 2023.

To harmonize various regulatory reviews, increase certainty among developers regarding anticipated regulatory timelines, and allow sufficient time for NMFS' production of a final biological opinion, BOEM and NMFS have agreed to a standardized ESA section 7 formal consultation timeline under the offshore wind program that allocates 150 days for consultation and production of a biological opinion for each proposed offshore wind project, unless an extension is necessary. The completion and issuance of the CVOW-C biological opinion was scheduled for on or before September 1, 2023; 150 days from the April 4, 2023 initiation date.

### **Consideration of the 2019 and Pre-2019 ESA Regulations**

On July 5, 2022, the U.S. District Court for the Northern District of California issued an order vacating the 2019 regulations that were revised or added to 50 CFR part 402 in 2019 ("2019 Regulations," see 84 FR 44976, August 27, 2019) without making a finding on the merits. On September 21, 2022, the U.S. Court of Appeals for the Ninth Circuit granted a temporary stay of the district court's July 5 order. On November 14, 2022, the Northern District of California issued an order granting the government's request for voluntary remand without vacating the 2019 regulations. The District Court issued a slightly amended order two days later on November 16, 2022. As a result, the 2019 regulations remain in effect, and we are applying the 2019 regulations here. For purposes of this consultation and in an abundance of caution, we considered whether the substantive analysis and conclusions articulated in this Opinion and its

incidental take statement would be any different under the pre-2019 regulations. We have determined that our analysis and conclusions would not be any different.

### **3 DESCRIPTION OF THE PROPOSED ACTIONS ON WHICH CONSULTATION WAS REQUESTED**

In this section and throughout the Opinion we use a number of different terms to describe different geographic areas of interest. For clarity, we define those terms here. The Wind Development Area (WDA) is the area consisting of the location of the WTGs, offshore substations, interarray cables, and the cable corridors between the offshore substations (OSS) and the landfall sites in Virginia. The Wind Farm Area (WFA) is that portion of CVOW-C's lease (OCS-A 0483) where the WTGs and OSSs will be installed and operated (i.e., the offshore portion of the WDA minus the cable routes to shore). The project area is the area consisting of the location of the WTGs, OSSs, interarray cables, and the cable corridors to shore, as well as all vessel transit routes to ports in Virginia (i.e., the WDA plus these transit routes). The action area is defined in Section 3.9 below and includes the project area, WDA, and WFA as well as the portion of the U.S. EEZ used by project vessels transiting from ports in the Gulf of Mexico, Canada, and Europe.

#### **3.1 Overview of Proposed Federal Actions**

BOEM is the lead Federal agency for the project for purposes of this ESA consultation and coordination under NEPA and other statutes. As described in Section 2 of this Opinion, BOEM requested consultation on its proposal to approve<sup>7</sup> a COP to authorize the construction, operation and maintenance, and eventual decommissioning of the CVOW-C Project. BSEE will work with BOEM to enforce safety, environmental, and conservation compliance with any associated legal and regulatory requirements during project construction and operations; oversee inspections/enforcement actions, as appropriate; oversee closeout verification efforts; oversee facility removal and inspections/monitoring; and oversee bottom clearance confirmation.

BOEM's request for consultation also included: EPA's proposal to issue an Outer Continental Shelf Air Permit; the USACE's proposal to issue a permit for in-water work, structures, and fill under Section 10 of the Rivers and Harbors Act of 1899 and Section 404 of the Clean Water Act; and the USCG proposal to issue a Private Aids to Navigation (PATON) Authorization. BOEM addressed NMFS OPR's proposal to issue a MMPA Incidental Take Authorization (ITA) in their request for consultation and NMFS OPR submitted a separate request for consultation. BOEM indicated it will require, through COP approval, all Project construction vessels to adhere to existing state and Federal regulations related to ballast and bilge water discharge, including USCG ballast discharge regulations (33 CFR §151.2025) and EPA National Pollutant Discharge Elimination System (NPDES) Vessel General Permit standards.

The information presented here reflects the proposed action described by BOEM in their March 23, 2023, BA and the proposed MMPA ITA (88 *Federal Register* 28656; May 4, 2023). Here, for simplicity, we may refer to BOEM's proposed action when that proposed action may also

---

<sup>7</sup> BOEM's regulations state at 30 CFR § 585.628(f): "Upon completion of our technical and environmental reviews and other reviews required by Federal law (e.g., CZMA), BOEM may approve, disapprove, or approve with modifications your COP."

include other Federal actions (e.g., construction of the wind turbines requires authorizations from BOEM, USACE, EPA, USCG, and NMFS OPR).

The project design envelope described in the COP includes up to 202 WTGs and 3 OSSs. Prior to the initiation of formal ESA consultation, the scope of the project was reduced to 176 WTGs due to technical and environmental constraints related to the availability of turbine positions and the Virginia State Corporation Commission’s approval, by issuance of a certificate of public convenience and need, of the construction of the project with 176 WTGs. The proposed action described in the BA and proposed MMPA ITA and analyzed in this Opinion thus consists of 176 WTGs with a capacity of approximately 14-16 megawatts (MW) per turbine (anticipated 14.7 MW), three OSSs, and a submarine transmission cable network connecting the WTGs to the OSSs, all of which will be located in BOEM Renewable Energy Lease Area OCS-A 0483, located within the Virginia Wind Energy Area. As described in more detail below, the WTG foundations will be 31 feet (ft; 9.5 meters [m]) diameter monopiles and the three OSSs will be installed on 9.2 ft (2.8 m) diameter pin pile foundations. The proposed action considers up to 183 independent piling events for monopile installation as Dominion Energy has determined they may need up to 7 WTGs re-piled in alternate positions due to unstable sediment conditions.

The Lease Area is located in Federal waters of the OCS, approximately 27 miles (44 kilometers [km]) east of Virginia Beach, Virginia. The proposed location of the WFA and the EC installation corridor are shown in Figure 1.

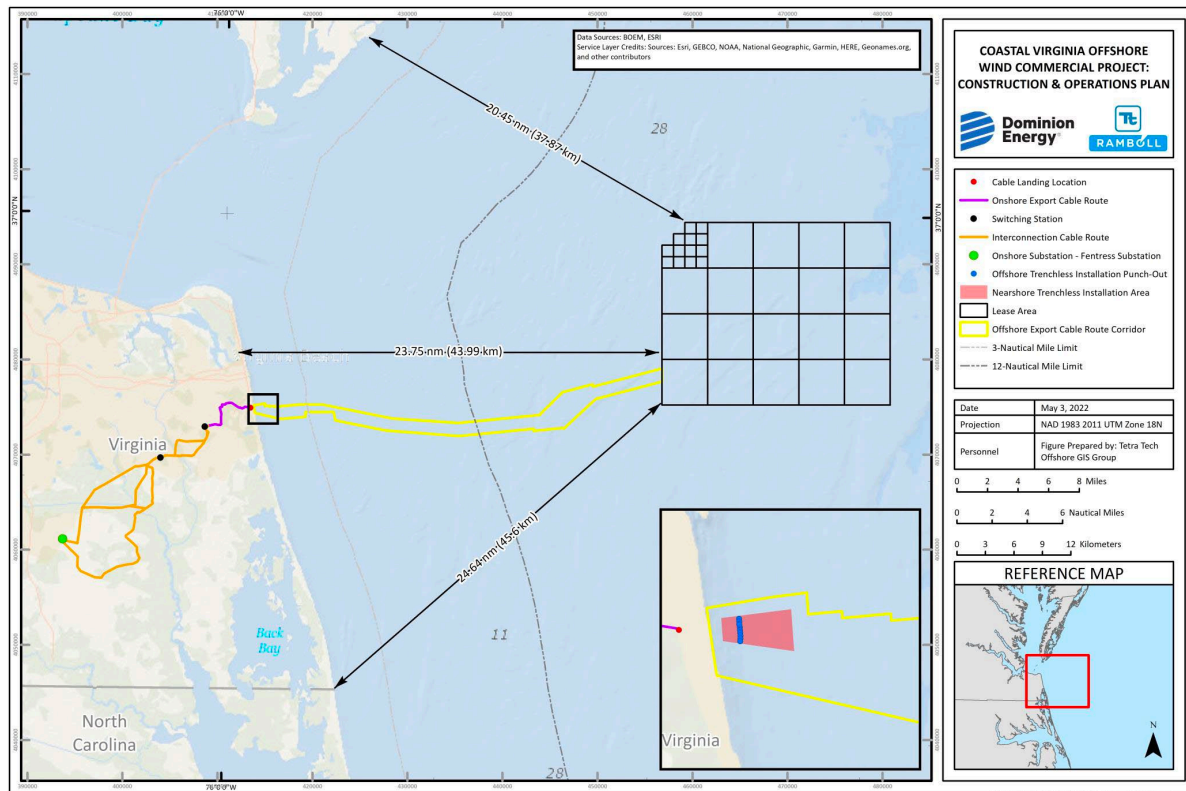

(Source: Figure 1-1 in BOEM’s BA)

**Figure 1. CVOW-C lease development area and export cable corridor.**



The EC will be a High Voltage Alternating Current (HVAC) electric cable that will be buried (see Cable Installation Section 3.2.3) to a target depth of 3.3 to 16.4 ft (1 to 5 m) below the seafloor in Federal waters and Virginia State territorial waters. The EC will connect the WFA to the electric grid in Virginia Beach, Virginia. Along with the cable landing location, onshore components of the project include the Onshore Substation, interconnection cables, switching station, and onshore export cables. A generalized schematic that represents the offshore and onshore components, as well as the connections is shown in Figure 2.

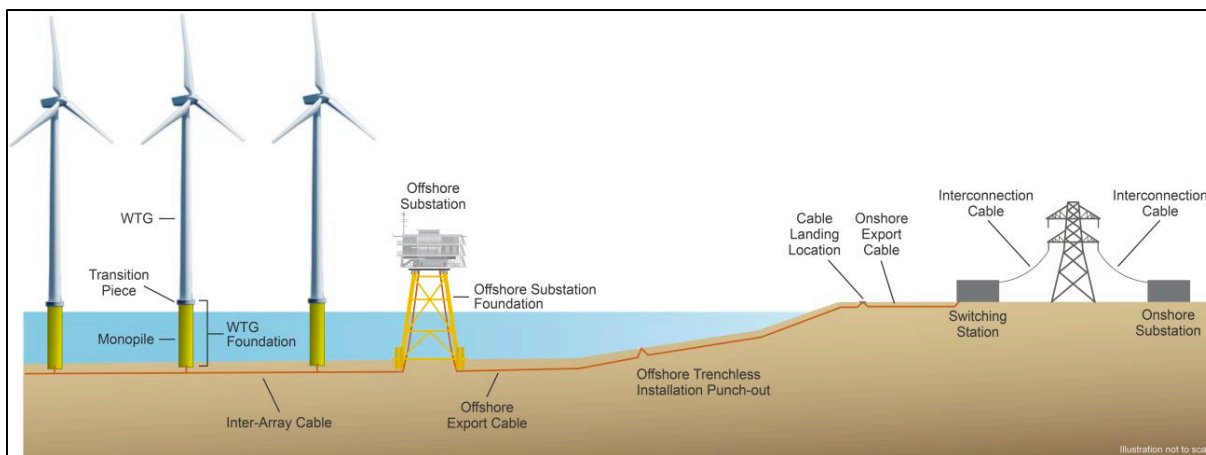

(Source: Figure 1-3 in BOEM's BA)

**Figure 2. Conceptual Project Schematic**

The project also includes high-resolution geophysical surveys (HRG), and a Fisheries Monitoring Plan to conduct biological research surveys. These survey activities will occur during the pre-construction, construction, and operation and maintenance phases of the project.

### 3.2 Construction

The CVOW-C project will begin with land-based construction in the fourth quarter of 2023 and construction of the offshore components would begin as soon as the first quarter of 2024. Commissioning, the process of components becoming operational and generating electricity, is planned for 2024 through 2027. The proposed general construction schedule is displayed in Figure 3 below.



Activity	2023		2024				2025				2026				2027	
	Q3	Q4	Q1	Q2	Q3	Q4	Q1	Q2	Q3	Q4	Q1	Q2	Q3	Q4	Q1	Q2
Scour Protection Pre-Installation			X	X	X	X										
Monopile and transition piece transport and onshore staging		X	X	X	X	X	X	X	X	X	X					
Monopile Installation (piling between May 1 and October 31) <sup>1</sup>				X	X	X		X	X	X						
Scour Protection Post-Installation							X	X	X	X						
Transition Piece Installation				X	X	X	X	X	X	X	X					
WTG pre-assembly and Installation								X	X	X	X	X	X	X	X	X
Inter-Array Cable Installation								X	X	X	X	X				
Offshore Substation Installation (piling between May 1 and October 31)					X	X	X	X	X							
Offshore Export Cable Installation		X	X	X	X	X	X	X								
Onshore Export and Interconnection Cable Installation	X	X	X	X	X	X	X	X	X							
Switching Station Construction	X	X	X	X	X	X	X	X								
Onshore Substation Upgrade Construction	X	X	X	X	X	X	X	X								
Commissioning				X	X	X	X	X	X	X	X	X	X	X	X	X

**Figure 3. Proposed Construction Schedule**

Source: Construction and Operations Plan Table 1.1-2 (Dominion Energy 2023)

WTG = wind turbine generator

<sup>a</sup> Dominion Energy anticipates that all WTG monopile and offshore substation jacket foundations will be installed by October 31, 2025. However, as a contingency to account for the potential for delays due to weather, other unanticipated events, or both, Dominion Energy has proposed installation of up to 15 foundations in 2026. If required to accommodate delays in the installation schedule, the 15 installations would occur between May 1 and September 30, 2026.

<sup>b</sup> Activities planned prior to March 2024 that could result in harassment of marine mammals include the unexploded ordnance (UXO) identification HRG surveys covered in the authorized UXO Survey Incidental Harassment Authorization (IHA) (Authorized May 27, 2022 to May 26, 2023) and HRG surveys planned for December 2023 to March 2024 that would be covered under a separate IHA, which would terminate with the start of the LOA approval. HRG Surveys preceding the start date of the LOA in March 2024 are not included.

### 3.2.1 Seafloor Clearance

Prior to installation of the jacket or monopile foundations, the site will be checked and cleared for debris, large boulders, and potential hazards. Based on the lack of encounters with boulders and rocks during extensive survey activities already conducted, Dominion Energy does not anticipate the need for boulder removal but has included the possibility that it may be needed following further detailed engineering and installation planning.

Route clearance will be performed along the offshore export cable route corridor and inter-array cable routes prior to installations, including surveys (see 3.5 for HRG surveys) and pre-lay grapnel runs to identify and remove as appropriate any obstructions within the cable installation corridors.

Boulder clearance or relocation is not currently anticipated under the Proposed Action; however, if determined to be necessary, the following would occur:

- At least 90 days prior to inter-array cable corridor preparation and cable installation (e.g., boulder relocation, pre-cut trenching, cable crossing installation, cable lay and burial) and foundation site preparation (e.g., scour protection installation), the Lessee must provide DOI with a boulder relocation plan.
- The plan shall include the following:
  - Areas where boulders >6.6 ft (>2 m) in diameter are anticipated to occur, and areas where boulders are expected to be relocated for project purposes.
  - Methods to minimize the quantity of seafloor obstructions from relocated boulders into areas identified as active (within the last 5 years) bottom trawl fishing areas.
- The USCG would be notified of all relocated boulders/seafloor obstructions. These locations would be marked by the USCG and a Notice to Mariners would be issued.

Boulder picking and boulder plowing are listed as contingency vessel roles in Table 4, summary of offshore vessels for construction, which could be used to relocate/remove surface or partially embedded boulders and debris. Boulder picking would be done with a grab that is lowered by crane to the seafloor, over the targeted boulder and once “grabbed,” the boulder is relocated a short distance away. For the boulder plow, boulder clearance is completed by a high-bollard pull vessel, with a towed plow generally forming an extended V-shaped configuration, splaying from the rear of the main chassis. The V-shaped configuration displaces any boulders to the extremities of the plow, thus establishing a clear corridor; multiple passes may be necessary. The size of the plow and extent of displacement may vary, and the area may not be regraded once cable installation is complete. If boulders are encountered during cable installation, they will be moved from the cable route while using a Hydroplow that is pulled by a vessel and contains a jetting system.

### Unexploded Ordnances

Unexploded ordnances (UXOs) are explosive weapons (bombs, bullets, shells, grenades, mines, etc.) that did not explode when they were employed and still pose a risk of detonation. Ocean disposal of munitions was also an accepted international practice until 1970, when it was prohibited by the Department of Defense. After analysis of preliminary survey data and available information, Dominion Energy has concluded that potential UXOs can be avoided through micrositing and non-detonation measures. Potential detonation of UXOs is not anticipated and is not included in the Proposed Action.

Dominion Energy intends to microsite around all UXOs to the maximum extent practicable. UXO identification surveys will be completed to allow for foundation micrositing and rerouting of the cable as necessary to avoid identified features where clearance is not possible. If micrositing is not feasible, personnel/contractors with UXO expertise will confirm that the UXO is “safe to handle,” meaning the risk of accidental detonation is as

low as reasonably possible given that industry standard handling procedures are followed before any manipulation is done to relocate the UXO to a safe location. The qualifications for UXO expertise and criteria for safe handling will be included in a UXO Disposition Plan that will be submitted to BOEM and BSEE in the fourth quarter of 2023. Confirmed UXOs will not be brought to the water surface, since exposure to the environment could raise the potential for accidental detonation. The seabed disturbance footprint for UXO mitigation, which will entail relocation of UXO that cannot be avoided by micrositing and rerouting, is anticipated to be approximately 161.5 ft<sup>2</sup> (15 m<sup>2</sup>) per mitigation of one UXO. Relocation of UXO will be done by first using a suction pump to uncover and reconfirm the classification of the UXO, then using a work-class remotely operated vessel's (aka WROV) articulated arm to place slings underneath the UXO, and finally lifting it and shifting it to a safe location. The UXO relocation would not be more than ~50 m from the original position, and the USCG would be notified of all relocated UXO. The USCG and NOAA will determine the most appropriate method of charting the UXO hazards on NOAA navigational charts. The offshore export cable route corridor and lease area may be designated on NOAA navigational charts as restricted areas and notated to indicate the presence of UXO, or each individual UXO location may be marked on the chart, or some combination of the two.

### 3.2.2 Foundations, Wind Turbine Generators (WTG) and Offshore Substations (OSS)

Scour protection will be installed at WTG foundation sites prior to the installation of the monopiles. Scour protection helps prevent seafloor erosion and scour from natural hydrodynamic processes. Scour protection will consist of small and large rocks sourced in the U.S. and/or from Canada, and will be installed with a dynamic positioning (DP) vessel equipped with a fallpipe that extends from the vessel toward the seabed and controls the fall of rock to land onto a targeted site. At some sites, a second layer might be installed after installation of the WTG monopile foundation, depending on the need for large-sized stones at those locations for scour protection. The total estimated area of disturbance for the 176 WTG foundations and associated scour protection could range from 30 to 102 acres (12 to 41 hectares).

The OSS foundations are not expected to need scour protection installed around the base of the piled jackets. However, if detailed engineering indicates the need for scour protection, it is estimated that up to 2.86 acres (1.16 hectares) of scour protection could be installed for each OSS foundation.

Dominion Energy would mount the WTGs on monopile foundations consisting of two parts: a lower foundation pile (monopile) driven into the seabed and an upper transition piece mounted on top of the monopile (together referred to as the WTG foundation), which have a maximum diameter of 31 ft (9.5 m). During installation, the monopile foundations will be lifted off by the on-board crane of the installation vessel with a dedicated lifting tool and placed on the seabed atop the pre-installed scour protection layers. It is estimated that a maximum of 55.7 acres (22.5 hectares) of seafloor will be temporarily disturbed by the jack-up vessels, from the spuds and anchoring, during WTG foundation installation. Each foundation will be initially installed to the target penetration depth via vibratory pile driving to reduce the risk of pile run, followed by impact pile driving using a maximum 4,000-kilojoule (kJ) impact hammer to complete the installation to the target depth of 82 – 165 ft (25 – 55 m), possibly up to a maximum of 197 ft (60 m) into the seabed. Monopiles will be installed by either one or more DP heavy lift vessels (HLVs) or jack-up vessels with sufficient crane capacity. Monopiles would be installed in two years (with a third year as contingency) between May 1 and October 31 to avoid the months with the highest density of North Atlantic right whales (NARW) in the project area (see Section 5.2, NARW). The piling schedule considers the following three scenarios, using comparable hammer energies for all scenarios:

**Scenario 1 (Standard Driving Schedule):** One monopile foundation is installed in a 24-hour period using a vibratory pile driving for a duration of 60 minutes followed by 85 minutes of impact pile driving.

**Scenario 2 (Hard-to-Drive Schedule):** One monopile foundation is installed in a 24-hour period using a “hard-to-drive” schedule where additional time is required to reach the target penetration requiring up to 30 minutes of vibratory pile driving followed by 99 minutes of impact pile driving.

**Scenario 3 (One Standard and One Hard-to-Drive Schedule):** Two monopile foundations are installed in a 24-hour period, one using the Standard Driving Schedule, and the other following the Hard-to-Drive Schedule which totals up to 90 minutes of vibratory pile driving followed by 184 minutes of impact pile driving for both foundations.

The primary indicator between the Standard Driving Schedule and Hard-to-Drive Schedule would be the local substrate conditions at the foundation installation which may require additional pile strikes with the impact hammer to reach pile stability and the target penetration depth. The number of strikes at each associated hammer energy are provided in Table 1.

**Table 1. Summary of pile strikes, piling progression, and pile strikes for the three WTG foundation installation scenarios**

Piling Scenario	Hammer Energy (%)	Hammer Energy (J)	Duration (minutes)	Strikes per Minute	Total Number of Strikes
Scenario 1 (Standard Driving Schedule)	20	800	8	42	324
	40	1,600	32	40	1,296
	80	3,200	36	36	1,296
	100	4,000	9	36	324
Scenario 2 (Hard-to-Drive Schedule)	20	800	13	42	558
	40	1,600	19	40	744
	80	3,200	31	36	1,116
	100	4,000	36	36	1,302
Scenario 3 (One Standard and One Hard-to-Drive Schedule)	20	800	21	42	882
	40	1,600	51	40	2,040
	80	3,200	67	36	2,412
	100	4,000	45	36	1,626

(Table 1-2 in BOEM's BA).

The exact number of WTG foundations requiring the piling schedule in each scenario is not known at this time; however, for the purposes of the modeling conducted for the COP (Appendix Z; Dominion Energy 2023) and the LOA application (Tetra Tech 2022b), a proposed pile installation schedule was developed using preliminary seabed data available for the wind farm area. The anticipated pile installation schedule, which includes the number of foundations installed under each of the three scenarios noted above is provided in Table 2.

**Table 2. Proposed pile-driving installation schedule for CVOW-C Project**

Year	Month	Total Number of Foundations Installed	Number Standard WTG Installations	Number Hard-to-Drive WTG Installations	Number of Days with Two WTGs Installed
2024	May	18	5	13	1
	June	25	6	19	6
	July	26	7	19	6
	August	2 WTGs, 12 OSSs	1	1	1
	September	13	3	10	0
	October	11	1	10	0
<b>2024 Total</b>		<b>95 WTGs, 12 OSSs</b>	<b>23</b>	<b>72</b>	<b>14</b>
2025	May	16	6	10	1
	June	22	8	14	6
	July	24	8	16	6
	August	20	6	14	6
	September	5	2	3	0
	October	1	1	0	0
<b>2025 Total</b>		<b>88 WTG</b>	<b>31</b>	<b>57</b>	<b>19</b>

(Table 1-3 in BOEM's BA) OSS = offshore substation; WTG = wind turbine generator.

After the lower foundation pile (monopile) is driven into the seabed, an upper transition piece is mounted on top of the monopile. The transition piece is connected to the WTG tower above and to the monopile below with bolted flanges. The transition piece also has a grout-filled skirt that acts to prevent water ingress to the monopile-transition piece bolted flange, access ladders, boat landing, and platforms.

Fully assembled towers will be the first components to be installed on the foundations, followed by the nacelle and blades. The project WTGs will have a traditional design with three blades and a horizontal rotor axis. The blades will be connected to a central hub, forming a rotor that turns a shaft connected to the generator. The generator will be located within the containing structure known as the nacelle situated adjacent to the rotor hub. The nacelle will be able to rotate or “yaw” on the vertical axis to face the oncoming wind direction. The power output is controlled by pitch regulation. The rotor speed is variable and is designed to maximize aerodynamic efficiency. A schematic of an installed foundation and assembled WTG is shown in Figure 4.

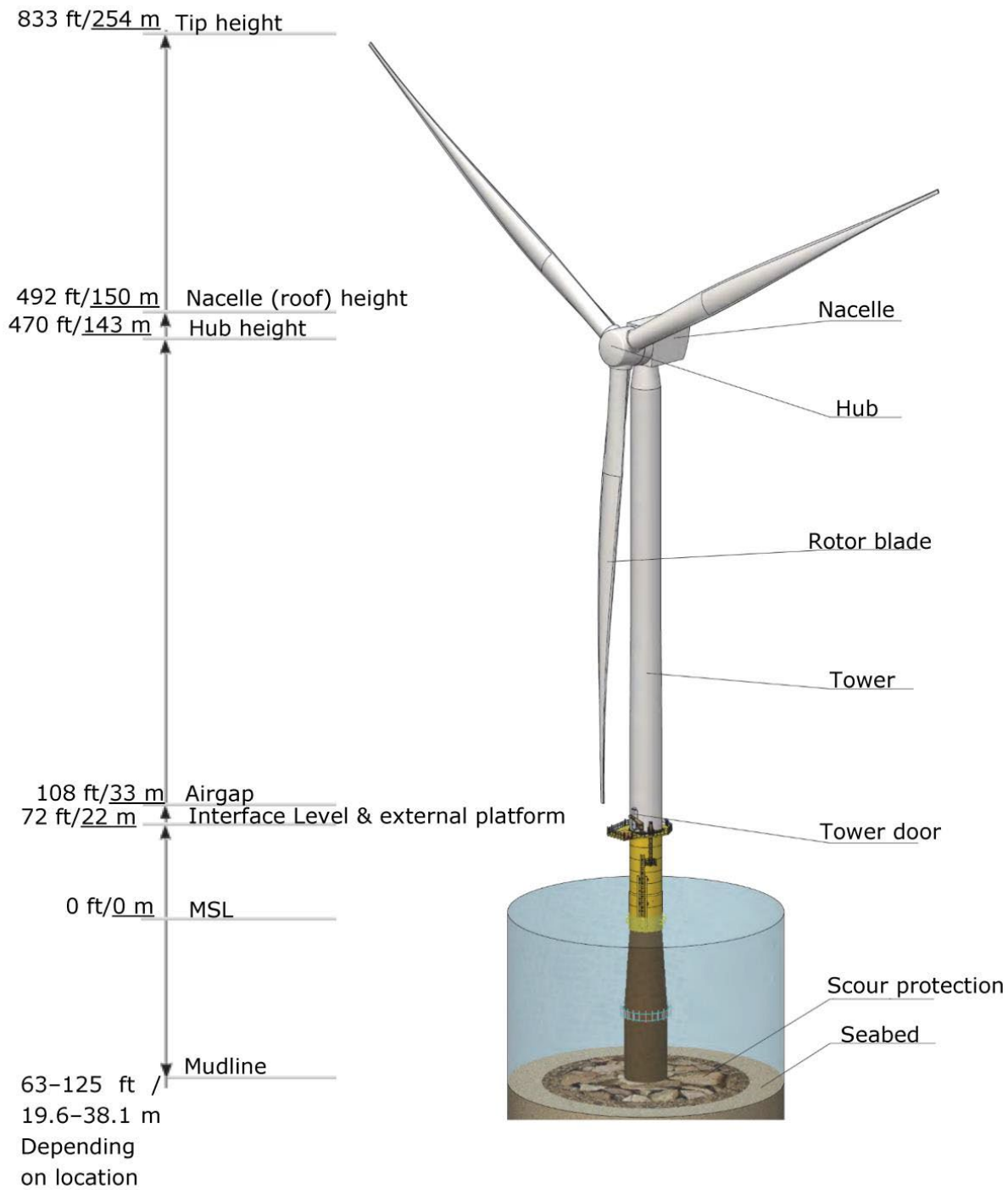

(Figure 3.3-1 in the COP)

**Figure 4. Schematic of installed foundation and assembled WTG.**

The final WTG layout (Figure 5) would be arranged in a grid pattern oriented at 35 degrees to minimize wake losses within the wind farm. WTGs would be spaced approximately 0.75 nautical mile (1.39 km) in an east-west direction and 0.93 nautical mile (1.72 km) in a north-south direction. The distances between some turbines in the final WTG layout may be slightly larger or smaller, as a result of the need to microsite, with some WTG foundation installation locations possibly shifting up to 500 ft (152 m) to avoid obstructions, sensitive cultural and natural resources, and due to local site condition variations. Turbine tip height as measured from mean sea level would be between 804 ft (245 m) and 869 ft (265 m). The distance from the bottom of the turbine tip to the highest astronomical tide would be between 82 ft (25 m) and 115 ft (35 m). A scaled representation of CVOW-C’s offshore components and WTG spacing are shown in Figure 6.

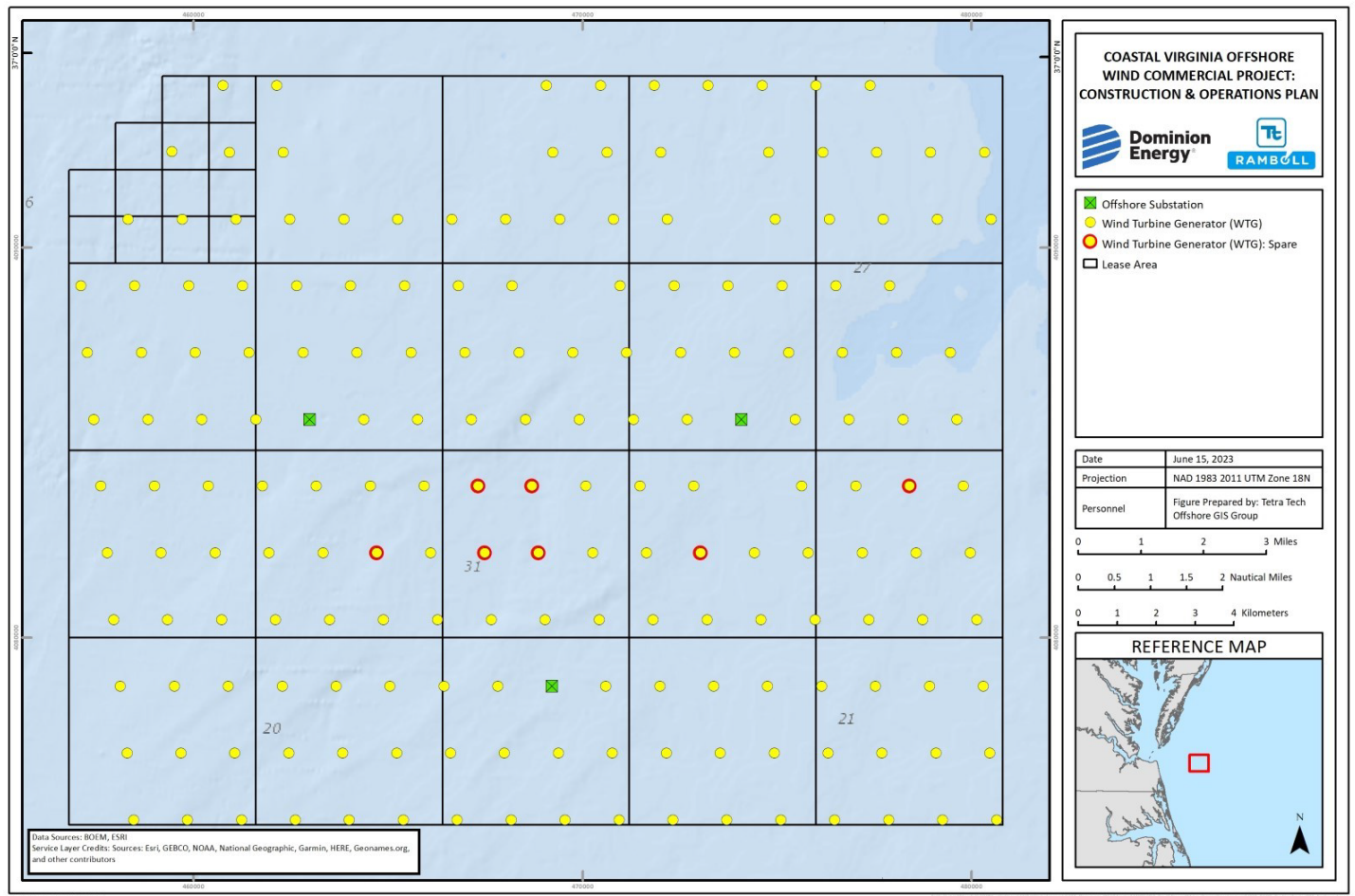

(Figure 1-6 in BOEM’s BA)

**Figure 5. CVOW-C WTG and offshore substation layout.**

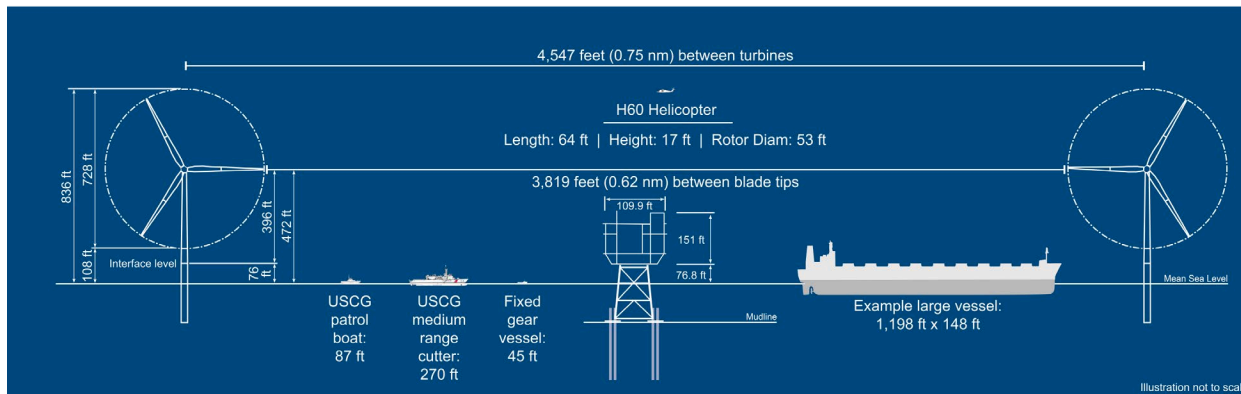

(Figure 1-7 in BOEMs BA)

**Figure 6. Scaled representation of CVOW-C’s proposed Offshore Project components and common vessel types relative to WTG rotor diameter and 0.75 nautical mile turbine spacing.**

Dominion Energy proposes to construct three OSSs. An OSS is an offshore platform containing the electrical components necessary to collect the power generated by the WTGs (via the Inter-Array Cable system) and transform it to a higher voltage for transmission and transport of that power to the Project’s onshore electricity infrastructure (via the Offshore Export Cables).

The OSSs would comprise two main components: a foundation attached to the seafloor and a topside to contain the decks holding the main electrical and support equipment. Dominion Energy is also considering adding a helideck to support monitoring and maintenance to each of the OSSs for normal and emergency access by helicopters. Dominion Energy is proposing to use pre-installed, piled, jacket foundations, which comprise four pin piles each with a maximum diameter of 9 ft (2.7 m) to support the OSSs.

Once the construction and installation location has been prepared, the jacket will be brought to the site using a feeder barge or vessel. The jacket will be lifted and placed in the designated target position via a floating DP HLV, which may temporarily disturb up to 3.6 acres (1.5 hectares) of seafloor during installation. The offshore substation jacket foundation piles will be installed before the jacket is placed on the seabed (i.e., pre-installed), so a piling template will be lowered onto the location where the jacket will be installed. It is estimated that a total of 1.9 acres (0.8 hectare) of seafloor will be temporarily disturbed by the pin pile template during installation. The OSS jacket foundations will be placed into the template and then will first be installed via vibratory pile driving to reduce the risk of pile run, followed by impact pile driving using a maximum 3,000-kJ impact hammer to complete the installation to the desired target penetration depth of 230 to 269 ft (70 to 82 m). The piling schedule scenario for the OSS includes up to two pin piles installed per day, requiring up to 120 minutes of vibratory pile driving followed by 410 minutes of impact pile driving for both pin piles. The number of strikes and associated hammer energies are provided in Table 3.

**Table 3. Pile strikes and progression for the Offshore Substation Foundation Installation**

Piling Scenario	Hammer Energy (%)	Hammer Energy (J)	Duration (minutes)	Strikes per Minute	Total Number of Strikes
Scenario 4 (OSS Piled Jacket Foundation)	20	600	36	42	1,512
	40	1,200	38	40	1,512
	80	2,400	84	36	3,024



Piling Scenario	Hammer Energy (%)	Hammer Energy (J)	Duration (minutes)	Strikes per Minute	Total Number of Strikes
	100	3,000	252	36	9,072

(Table 1-4 BOEM's BA).

It is currently proposed that all 12 jacket pin piles for the OSS will be installed during August 2024. However, like the WTG monopile foundations, any changes to the schedule would remain between May and October of each year to avoid the months with the greatest densities of NARWs.

### 3.2.3 Cable Installation

The inter-array cable system would be composed of a series of cable “strings” that interconnect a small grouping of WTGs to the offshore substations. The inter-array cables would consist of strings of three-core copper, aluminum conductor, or both, with a rated voltage of 72.5 kV and an operating voltage of 66 kV, connecting up to six WTGs per string. The WTG strings would be connected to each other via link/switch, and each OSS would be tied to a WTG string. Dominion Energy anticipates approximately 12 WTG strings would be connected to each OSS, for a total of 36 WTG strings. However, the number of WTGs per string, the number of WTG strings, or both connecting to each OSS may be modified given the final layout of WTGs.

The offshore export cables would transfer the electricity from the OSS to the cable landing location in Virginia Beach, Virginia. Electricity would be transferred from each of the three OSSs to the cable landing location via three three-core copper, aluminum-conductor 230-kV subsea cables, or both, for a total of nine offshore export cables. The offshore export cable route corridor width associated with the three cables originating from each OSS would be 1,280 ft (390 m). Upon exiting the Lease Area, the three offshore export cable route corridors originating at the OSS would merge to become one overall offshore export cable route corridor containing all nine offshore export cables. The offshore export cable route corridor between the western edge of the Lease Area and the cable landing location would range in width from 1,970 ft (600 m) to 9,400 ft (2,865 m).

Variability in the offshore export cable route corridor width would be driven by several external constraints, including existing telecommunications cable and transmission cable crossings; the U.S. Department of Defense exclusion area to the south; the vessel traffic lane and proposed Atlantic Coast Port Access Study safety fairway to the north; the Dam Neck Ocean Disposal Site; obstructions, exclusion areas, and seabed conditions identified from existing data and ongoing surveys; potential risks due to the use of the area by third parties; and the approach to the horizontal directional drilling at the cable landing location. Within the offshore export cable route corridor, the nine offshore export cables would generally be spaced approximately 164 to 2,716 ft (50 to 828 m) apart and constrained at times to be spaced 164 to 328 ft (50 to 100 m) apart.

Dominion Energy has proposed several cable installation methods for the inter-array and offshore export cables. The most likely cable burial methods being considered for the project include jet plow, jet trenching, hydroplow (simultaneous lay and burial), vertical injector, trenching ROV, mechanical plowing (simultaneous lay and burial), or a combination of these technologies. Final installation methods would be determined by the final engineering design process that is informed by detailed geotechnical data, risk assessments, and coordination with stakeholders. For all the proposed installation methods, a narrow temporary trench is created into which the cable is bed while the equipment is towed along the seabed. Inter-array cables would be up to 7.1 inches (in; 180 millimeters [mm]) in diameter. Offshore export cables would have an outside diameter up to 11.4 in (290 mm). Inter-array cables would be buried to a depth of between 3.9 and 9.8 ft (1.2 and 3 m); however, the exact depth would be dependent on the substrate encountered along the route. The offshore export cables would be buried to a target depth of between 3.3 and 16.4 ft (1 and 5 m), which is consistent with the recommendations from the preliminary Cable Burial Risk Assessment (COP Appendix W; Dominion Energy 2023). Post-lay

surveys will be conducted using a remotely operated vehicle or burial assessment sled to determine the need for secondary cable protection measures such as rocks, geotextile sand containers, basalt sand containers, or concrete mattresses.

Dominion Energy has identified three in-service fiber optic telecommunications cables within the offshore export cable route corridor that would be crossed by the offshore export cables at three locations and at the Omega joint location between mile posts 13 and 17 (kilometer posts 21 and 28). It is anticipated that the presence of the fiber optic cables may make it difficult to reach the desired cable burial depth for the CVOW project export cable at those crossings and so cable protection may be needed for the existing infrastructure and the offshore export cables. The protection and crossing method would be determined on a case-by-case basis. At a minimum, it is expected that each asset crossing would include two layers of cable protection installed prior to and post offshore export cable installation, and a potential third layer of protection if stabilization and scour protection is deemed necessary.

### **3.2.4 Cable Landfall Connection**

Dominion Energy would install both temporary goal posts and temporary cofferdams, requiring pile driving, during construction to support the connection of the offshore cable with the onshore cable, approximately 1,000 m (3,281 ft) offshore of the State Military Reservation in Virginia Beach, Virginia. The goal posts and cofferdams require pile driving to be installed, once installed they would support work associated with installing casing pipes housing the export cables. Dominion Energy would install 9 casing pipes approximately 15.2 m (50 ft) apart from each other at the cable landfall construction site using a Trenchless Installation, a tunneling approach similar to horizontal directional drilling.

The goal posts would consist of 1.07 m (42 in) steel pipe piles that would be installed using an impact hammer for up to 130 minutes daily (a maximum of 2 installed per day). The duration of each strike of the impact hammer would be between 0.5 - 2 seconds in duration and necessitate approximately 260 strikes per pile. There are 12 goal posts per each of the nine direct pipe locations, a total of 108 piles would be installed. Up to 2 piles would be installed per day, there could be 520 strikes per day. To install all goal posts, Dominion Energy would conduct pile driving for 54 days.

Once installed, the goal posts can be removed using equipment not expected to generate any underwater acoustic noise as the majority of the force applied would be to overcome the skin friction of the material that is embedded in the substrate. This is expected to consist of pulling/tugging of the piles using mechanical or hydraulic equipment and take a similar amount of time of installation (i.e., a total of 54 days for removal, although no take is expected). Based on Dominion Energy's schedule, which includes both installation and removal of the goal posts, these activities are expected to occur in 2024, between May 1<sup>st</sup> and October 31<sup>st</sup>, and necessitate approximately 6 months for complete installation and removal.

Up to nine temporary cofferdams may be necessary during cable landfall connection construction activities, which would be installed and removed via vibratory pile driving. Each temporary cofferdam would consist of 30 to 40 steel sheet piles measuring 0.51 m (20 in) in diameter arranged in a predetermined configuration (270 to 360 steel sheet piles total for all nine cofferdams). Vibratory pile drivers would be used to both install and remove the steel sheet piles. Each sheet pile would necessitate approximately 2 to 3 minutes of active drive time for installation, at a maximum installation rate of 20 sheet piles per day (up to 40 - 60 minutes daily). Dominion Energy assumes installation will take approximately 3 days (180 minutes total) per cofferdam. Removal of these sheet piles would also occur by a vibratory driver and is estimated to take approximately the same amount of time to remove as it was to install for a total of 3 days per cofferdam. A single cofferdam would take a total of 6 days to install and remove. In total, pile driving (installation and removal) associated with all cofferdams would

occur over 54 non-consecutive days. In the event cofferdams are not feasible, Dominion Energy proposes using utilize a controlled flow excavation (CFE) tool to excavate a targeted area to expose each Direct Pipe conduit “pipe” for the respective cable pull-ins. The use of jets of water to move sand means the substrate is not entrained or removed. If Dominion Energy utilizes the CFE methodology, an estimated total disturbed area of less than 1.0 acre (0.4 Hectares) is expected for the nine (9) punch-out installations. Disturbance associated with the CFE methodology would occur within the 8.8 ac (3.6 Hectares) temporary workspace area presented in the COP and EIS.

### 3.2.5 Vessels

Various types of vessels will be used during construction and installation, O&M, and decommissioning. The construction and decommissioning phases will involve more intensive periods of activity over a few years, whereas O&M related vessel traffic would occur intermittently over the life of the project.

The construction and installation phase would use both construction and support vessels. Details and specifications on vessels expected to be used during construction are in Table 4, based on the information in COP Section 3.4.1.5 (Dominion Energy 2023). Daily estimated vessel trips would average 46 trips per day through the duration of construction, but it would be dependent on the construction period and activities, with a range of three trips per day minimum to a maximum of 95 trips per day. Construction vessels would travel between the project area and various ports identified in Table 4, depending on the vessel role. Dominion Energy and the Port of Virginia have executed a lease agreement for a portion of the existing PMT facility in the city of Portsmouth, Virginia to serve as a construction port for the majority of construction vessels. The port would be used to store monopile and transition pieces and to store and pre-assemble WTG components. Table 4 presents the available information of vessels and transits that are currently anticipated for the Proposed Action as described in BOEM’s BA. We also note that BOEM has indicated that a single vessel trip from the Gulf of Mexico is anticipated as Dominion has commissioned the construction of a purpose built offshore wind support vessel from a manufacturer in Texas. This is the only vessel transit from a port in the Gulf of Mexico that is considered part of the proposed action.

**Table 4. Summary of offshore vessels for construction in the Proposed Action**

Vessel Role	Vessel Class	# of Vessels	Width (ft)	Length (ft)	Draft (ft)	Most Likely Operation Period	Frequency of Transit	Transit Origin to Project Area
Scour Protection Installation	Fall Pipe Vessel	1	106	507	25	10/2023 to 12/2024 and 02/2025 to 10/2025	Weekly	Canada/USA
Transport monopile/transition pieces from U.S. port to installation site	U.S. barge	2	130	400	20	04/2024 to 12/2025	$(188+17)/2 = 103$ cycles in total for all barges	Portsmouth, VA
Tugs for MP/TP transport barges	U.S. ocean-going tug	3	41	132	18	04/2024 to 12/2025	$103 + 52 = 155$ cycles in total	Portsmouth, VA
Monopile/transition piece/Offshore Substation Installation	HLV	1	161	711	36	04/2024 to 12/2025	Monthly	Europe/ Hampton Roads, VA

Vessel Role	Vessel Class	# of Vessels	Width (ft)	Length (ft)	Draft (ft)	Most Likely Operation Period	Frequency of Transit	Transit Origin to Project Area
Noise Monitoring	CTV	2	34	84	7	05/2024 to 10/2024 and 05/2025 to 10/2025	Daily	Portsmouth, VA
Noise Mitigation	Platform Support Vessel	1	100	454	29	05/2024 to 10/2024 and 05/2025 to 10/2025	2 cycles in total + X due to bad weather	Portsmouth, VA
Crew Transfer	CTV	1	23	65	6	04/2024 to 12/2025	Every 2 <sup>nd</sup> day	Portsmouth, VA
Jacket Installation	DP HLV	1	161	710	36	N/A	Monthly	Europe/ Hampton Roads, VA
Noise Monitoring for Jacket Installation	CTV	2	34	84	7	N/A	Daily	Portsmouth, VA
Noise Mitigation for Jacket Installation	Platform Support Vessel	1	100	454	29	N/A	Daily	Portsmouth, VA
Transport jackets/topsides from EU port to installation site	HLV	1	138	568	35	11/2024 to 04/2025	3 cycles in total	Europe
Assist tugboat for topside installation	U.S. ocean-going tug	1	35	112	19	12/2024 to 04/2025	Daily	Hampton Roads, VA
Offshore Cable Commissioning (CONTINGENCY VESSEL)	DP2 JUV	2	230	132	20	11/2024 to 07/2025	Monthly	N/A
Nearshore Trenchless Installation	Drill Rig spread	2	40	9	N/A	09/2023 to 02/2024	N/A (Staged at the 9 direct pipe punchout locations)	Hampton Roads, VA
Nearshore Marine assistance	U.S. Multi-Purpose Support Vessel (Multicat)	2	40	92	14	09/2023 to 02/2024	Weekly	Portsmouth, VA
Nearshore Marine assistance	U.S. tug (small)	1	35	112	19	09/2023 to 02/2024	Daily – with intermittent periods between each of the 9 installation areas to support HDPE pull-in	Portsmouth, VA
Landfall	Landfall Beach spread	1	N/A	N/A	N/A	01/2023 to 04/2024 and 07/2024 to 09/2025	Weekly	Hampton Roads, VA

Vessel Role	Vessel Class	# of Vessels	Width (ft)	Length (ft)	Draft (ft)	Most Likely Operation Period	Frequency of Transit	Transit Origin to Project Area
Shore pull-in	U.S. Pull-in support barge	1	105	400	20	01/2023 to 04/2024 and 07/2024 to 09/2025	Weekly	Portsmouth, VA
Shore pull-in	U.S. workboat (tug)	4	41	132	18	01/2023 to 04/2024 and 07/2024 to 09/2025	Weekly	Portsmouth, VA
Cable Lift Jack-Up Installation Vessel – CONTINGENCY VESSEL	JUV	1	105	144	13	01/2023 to 04/2024 and 07/2024 to 09/2025	N/A	N/A
Pre-lay Grapnel Run	Multipurpose Support Vessel	1	59	266	19	01/2023 to 04/2024 and 07/2024 to 09/2025	Weekly	Portsmouth, VA
Pre-Installation Survey	Survey Vessel	1	34	87	10	01/2023 to 04/2024 and 07/2024 to 09/2025	Weekly	Portsmouth, VA
Cable Laying and Burial	Shallow-draft Cable Lay Vessel	1	110	401	18	01/2023 to 04/2024 and 07/2024 to 09/2025	Monthly	Europe/Hampton Roads, VA
Anchor handling	Multi-Purpose Support Vessel (Multicat)	2	40	92	14	01/2023 to 04/2024 and 07/2024 to 09/2025	Daily	Hampton Roads, VA
Transport Cable	Multipurpose Support Vessel	3	79	289	15	01/2023 to 04/2024 and 07/2024 to 09/2025	Single Trip	Europe/Hampton Roads, VA
Cable Burial	Hydro-plow (Jetting)	1	20	53	14	01/2023 to 04/2024 and 07/2024 to 09/2025	N/A	Europe/Hampton Roads, VA
Crew Transfer	CTV	1	34	87	10	01/2023 to 04/2024 and 07/2024 to 09/2025	Every 2 <sup>nd</sup> day	Portsmouth, VA
As-built Survey	Survey Vessel	1	34	87	10	01/2023 to 04/2024 and 07/2024 to 09/2025	Weekly	Portsmouth, VA
Pre-lay Survey (Offshore Export Cable)	Survey Vessel	1	34	87	10	01/2023 to 04/2024 and 07/2024 to 09/2025 and 11/2025 to 02/2026	Weekly	Portsmouth, VA

Vessel Role	Vessel Class	# of Vessels	Width (ft)	Length (ft)	Draft (ft)	Most Likely Operation Period	Frequency of Transit	Transit Origin to Project Area
Cable Laying and burial (Offshore Export Cable)	Deep-draft Cable Lay Vessel	1	106	528	22	01/2023 to 04/2024 and 07/2024 to 09/2025	Monthly	Hampton Roads, VA
Cable Laying and burial (Offshore Export Cable)	Deep-draft Cable Lay Vessel	1	39	110	9	01/2023 to 04/2024 and 07/2024 to 09/2025	Monthly	Europe/Hampton Roads, VA
Cable Burial (Offshore Export Cable)	Trenching Support or cable laying Vessel	1	105	529	25	01/2023 to 04/2024 and 07/2024 to 09/2025	Monthly	Europe/Hampton Roads, VA
Cable Burial (Offshore Export Cable)	Trenching Support Vessel or Cable laying Vessel	1	112	561	28	01/2023 to 04/2024 and 07/2024 to 09/2025	Monthly	Europe/Hampton Roads, VA
Cable Burial (Offshore Export Cable)	Burial tool (Post-lay Jetting)	2	25	46	19	01/2023 to 04/2024 and 07/2024 to 09/2025	Monthly	Europe/Hampton Roads, VA
Offshore Jointing Vessel (Offshore Export Cable)		1	23	565	6	01/2023 to 04/2024 and 07/2024 to 09/2025	Monthly	Europe/Hampton Roads, VA
Pre-lay Grapnel Run (Inter-Array Cable)	Multipurpose Support Vessel	1	26	92	9	01/2023 to 04/2024 and 11/2024 to 05/2026	Weekly	Portsmouth, VA
Pre-lay Survey (Inter-Array Cable)	Survey Vessel	1	23	85	5	01/2023 to 04/2024 and 11/2024 to 05/2026	Weekly	Portsmouth, VA
Cable Laying and burial (Inter-Array Cable)	Deep-draft Cable Lay Vessel	1	106	528	25	01/2023 to 04/2024 and 11/2024 to 05/2026	Every 60 days	Europe/Hampton Roads, VA
Multipurpose Service Vessel (Inter-Array Cable)	W2W	2	76	292	18	01/2023 to 04/2024 and 11/2024 to 05/2026	Monthly	Hampton Roads, VA
Crew Transfer (Inter-Array Cable)	CTV	2	23	65	6	01/2023 to 04/2024 and 11/2024 to 05/2026	Every 2 <sup>nd</sup> day	Portsmouth, VA
Cable Burial (Inter-Array Cable)	Trenching Support Vessel or Cable Laying Vessel	1	105	529	37	01/2023 to 04/2024 and 11/2024 to 05/2026	Every 60 days	Hampton Roads, VA

Vessel Role	Vessel Class	# of Vessels	Width (ft)	Length (ft)	Draft (ft)	Most Likely Operation Period	Frequency of Transit	Transit Origin to Project Area
Cable Burial (Inter-Array Cable)	Burial tool (Post-lay Jetting)	1	25	46	19	01/2023 to 04/2024 and 11/2024 to 05/2026	Every 60 days	Hampton Roads, VA
As-built Survey (Inter- Array Cable)	Deep-draft Cable Lay Vessel	1	106	528	25	01/2023 to 04/2024 and 11/2024 to 05/2026	Weekly	Portsmouth, VA
WTG Installation	JUV	1	184	472	23	08/2025 to 02/2027	Every 10-14 days	Portsmouth, VA
Transport WTGs from U.S. port to installation site	U.S. barge	2	100	400	20	08/2025 to 02/2027	Approximately every 3 days	Portsmouth, VA
Transport WTGs from U.S. port to installation site	U.S. ocean going tug	2	41	132	18	08/2025 to 02/2027	Approximately every 3 days	Portsmouth, VA
Assist tugboat	U.S. ocean going tug	1	35	112	19	08/2025 to 02/2027	Approximately every 3 days	Hampton Roads, VA
Commissioning spread	Multirole subsea Support Vessel with W2W	1	52	354	18	08/2025 to 04/2027	Bi-weekly	Portsmouth, VA
Site Security	Safety vessel, Nearshore Trenchless Installation	1	var	var	var	09/2023 to 08/2027	Bi-weekly	Portsmouth, VA
Boulder Picking (CONTINGENCY VESSEL)	Anchor Handling Tug + crane barge	2	46	146	21	2023	Weekly	Portsmouth, VA
Boulder Plowing (Contingency Vessel)	Anchor Handling Tug + towed plow	1	36	190	11	2023	Weekly	Portsmouth, VA
Crossing Protection (concrete mattresses)	Fall Pipe Vessel or Deep Draft Cable Lay Vessel	1	46	146	21	2024 to 2026	Between 3 and 27 cycles	Portsmouth, VA

AHT = anchor handling tug; CTV = crew transfer vessel; HLV = heavy lift vessel; JUV = jack-up vessel; N/A/ = not applicable; VA = Virginia, W2W = walk-to-work vessel

### 3.3 Operations and Maintenance (O&M)

The commercial lifespan of the CVOW-C project is expected to be up to 33 years, based on the operations term of the project specified in the Lease. Dominion Energy intends to lease an existing O&M facility with the preferred location at Lambert's Point, located on a brownfield site in Norfolk, Virginia. The O&M facility would monitor operations and would include office space, a control room, warehouse, shop, and pier space.

The project O&M plan will be finalized as a component of the required Facility Design Report/Fabrication Installation Report, and planned and unplanned inspections, including preventive maintenance based on

statutory requirements, original equipment manufacturers' guidelines, and industry best practices. Dominion Energy will develop and implement a Safety Management System and an Oil Spill Response Plan prior to construction and installation activities in coordination with BOEM and the Bureau of Safety and Environmental Enforcement (COP, Appendices A and Q; Dominion Energy 2023).

Primary offshore O&M activities will include:

- Inspections of Offshore Project components for signs of corrosion, quality of coatings, and structural integrity of the WTG components.
- Inspections and maintenance of the WTG and OSS electrical components/equipment.
- Surveys of the offshore export cable and inter-array cable routes, to confirm the cables have not become exposed or that any cable protection measures have not worn away. Dominion Energy anticipates that post-installation cable surveys will occur once per year, which could be done with ROVs or HRG equipment. However, the final frequency and schedule of these surveys will be determined in coordination with the applicable agencies.
- Sampling and testing (of lubricating oils, etc.).
- Replacement of consumable items (such as filters and hydraulic oils).
- Repair or replacement of worn, failed, or defective systems (such as WTG blades, bolts, corrosion protection systems, protective coatings, cables, etc.), realigning machinery, renewing cable protection using additional rock dumping or mattress placement, etc.
- Updating or improving systems (such as control systems, sensors, etc.).
- Disposal of waste materials and parts (in line with best practice and regulatory requirements).

The WTGs would be monitored through a supervisory control and data acquisition system and offshore export cables and inter-array cables would be monitored through distributed temperature sensing equipment to provide real-time detection of possible faults. Dominion Energy would repair or replace components in the event of a fault or failure. The duration of repair time for offshore components could vary greatly depending on the severity of the repair fault or failure; however, Dominion Energy has estimated repair duration ranges of up to 8 days for work related to WTGs or OSSs, and could be up to 21 days for cables. It is anticipated that the repair vessel would remain in the lease area or cable corridor for the duration of the repair. Vessels would not be transiting in and out of port each day.

Appropriate safety systems would be included on all WTGs, including fire detection and an audible and visible warning system, painting and marking, lightning protection, and aids to navigation in accordance with USCG requirements, with required lighting for the aviation and maritime industries.

Each of the WTGs will require various oils and lubricants to operate, Table 5 provides a summary with anticipated volumes. Dominion Energy does not anticipate the need for fuel during the operation of the WTGs.

**Table 5. Expected oil/lubricants for WTGs**

WTG Component	Oil/Lubricant	Type	Expected Amount
Nacelle	Grease (lubrication systems)	Optipit (Castrol), Mobilith 007	82 gallons (gal, 310 liters [1])
	Water/glycol (cooling fluid)	BASF Glysantin G30-91	476 gal (1,800 l)



	Gear oil (yaw gears)	Castrol Optigear Synthetic X 320	63 gal (238 l)
	Ester Oil (Transformer)	Midel 7131	1,717 gal (6,500 l)
Hollow shaft (Generator)	Hydraulic oil (hydraulic system)	Castrol Hyspin AWH-M32	132 gal (500 l)
Hub	Grease (lubrication systems)	Shell Rhodina BBZ	48 gal (180 l)
	Hydraulic oil (pitch system hydraulic accumulators)	Castrol Hyspin AWH-M32	92 gal (350 l)
	Nitrogen (pitch system hydraulic accumulators)	Nitrogen	16,643 gal (63,000 l)
Tower	Water/Glycol or Heavy Liquid (damping liquid)	BASF Glysantin G30-91 (33% volume wise) or DAMLES ACI Density 450	3,698 gal (14,000 l) a/

Note: a/ Final volume and type are subject to Project-specific WTG configuration

Each of the OSSs will require various oils, fuels, and lubricants to operate, Table 6, provides a summary with anticipated volumes. Sulfur hexafluoride (SF<sub>6</sub>) gas would also be used for electrical insulation purposes.

**Table 6. Expected Oil/Fuel/Lubricants for OSSs**

Offshore Substation Component	Oil/Fuel/Lubricant	Type	Expected Amount
Transformer	Mineral oil	Shell Diala S4 ZX-1	55,500 gallons (gal) (210,000 liters [l])
Shunt Reactor	Mineral oil	-	26,400 gal (100,000 l)
Earthing Transformer	Dielectric insulating fluid	MIDEL 7131	4,200 gal (15,750 l)
66 kV Gas Insulated Switchgear	Sulfur hexafluoride gas	-	4,409 pounds (lb) (2,000 kilograms [kg])
235 kV Gas Insulated Switchgear	Sulfur hexafluoride gas	-	5,070 lb (2,300 kg)
Diesel Generator Tank	Marine Diesel	-	6,604 gal (24,999 l)

The WTGs and OSS topside designs are expected to minimize the potential for spills and leaks through the implementation of containment measures. The spill containment strategy consists of preventive, detective, and containment measures (see Appendix Q, Oil Spill Response Plan; Dominion Energy 2023). The WTGs and OSSs will have sensors to indicate any failures based on remote monitoring. In addition, the service operations vessel will perform routine maintenance with an anticipated frequency of one trip every two weeks. Personnel on this vessel will include credentialed mariners capable of identifying a sheen or emulsion in the water. Each OSS will also contain a collection and sump system with an oil water separator system. The OSSs will have closed cooling systems and will not have any water withdrawals or process water discharges. Each fluid source within a WTGs or OSSs has drip trays, pans, or other systems to collect any discharged/released fluids. Each pan or tray has a drain system leading down the tower to a collection point in the lower storage space. Dominion Energy will have a contractor transfer, and dispose of recovered oil and oil-contaminated materials and to ensure that all disposal is in accordance with Federal, State, and local requirements.

### **3.3.1 Vessel Operations**

Crew transfer vessels and service operation vessels would be used to support O&M activities offshore. A helicopter is also being considered to support the Project's commissioning activities, with an estimated 588 round trips to the Norfolk International Airport.

Dominion Energy anticipates 365 operating days for a single service operations vessel (SOV) and two crew transfer vessels (CTVs), with 26 annual round trips per vessel to the O&M port. In addition, Dominion Energy estimates 6 annual round trips to the O&M port for one survey vessel, as well as 2 annual round trips to the O&M port for one WTG maintenance jack-up vessel. Dominion Energy also estimates 4 annual round trips each to the O&M port for one scour protection vessel and one cable lay vessel.

### **3.4 Decommissioning**

In accordance with 30 CFR 585 and other BSEE and BOEM requirements, Dominion Energy would be required to remove or decommission all Project infrastructure and clear the seabed of all obstructions following the end of the Project's O&M activities. Unless otherwise authorized by BOEM or BSEE, Dominion Energy will achieve complete decommissioning within two years of termination of the lease and either reuse, recycle, or responsibly dispose of all materials removed. If the COP is approved or approved with modifications, Dominion Energy would have to submit a bond that would be held by the U.S. government to cover the cost of decommissioning the entire facility if Dominion Energy would not otherwise be able to decommission the facility.

Details on removal methods and assumptions in Table 7 are applicable based on current understanding of available decommissioning approaches. Dominion Energy would also perform site clearance surveys after the project material is removed to confirm all components have been properly removed and the project area is cleared of obstructions. Although the Proposed Action has a designated lifespan of 33 years, some installations and components may remain fit for continued service after this time. Dominion Energy would have to apply for an extension to operate the Proposed Action for more than the operations term.

In general, the decommissioning process for the WTGs and OSSs is anticipated to be the reverse of construction and installation, with turbine components or the OSS topside structure removed prior to foundation removal. Removal of all WTG components include the rotor, nacelle, blades, and tower. Materials would be brought onshore for recycling and disposal. WTG monopile foundations and the OSS piled jacket foundations would be removed by cutting below the mud line and lifting the foundation off by a heavy lift vessel to a barge. All foundations would need to be removed to 15 ft (4.6 m) below the mudline (30 CFR 585.910(a)). The steel

used in the foundations and towers would be recycled. The scour protection placed around the base of each foundation, if used, would be removed unless leaving in place is deemed appropriate through consultation with appropriate authorities. Offshore export cables and inter-array cables would be reeled in or lifted out and then cut into pieces and then recycled, or cables would be retired in place; Dominion Energy would need to obtain separate and subsequent approval from BOEM to retire any portion of the project in place (Dominion Energy 2023). The number and type of vessels required for project decommissioning would be similar to those used during project construction, with the exception that impact pile driving would not be required. As such, while the same class of vessel used for foundation installation may be used for decommissioning, that vessel would not be equipped with an impact hammer. BOEM has not identified the number of likely vessel transits that would be necessary to support decommissioning activities; however, based on descriptions of conceptual decommissioning for similar projects, BOEM anticipates that vessel transits during decommissioning would be similar to those during construction. Ports of origin and destinations for those vessels are currently unknown.

**Table 7. Summary of decommissioning methods and assumptions**

<b>Project Component</b>	<b>Removal Method</b>	<b>Comments and Assumptions</b>
Wind Turbine Generator (WTG)	Removal of the WTGs is done using a reversed construction and installation method. Decommissioning of the turbines and towers is assumed to include removal of the rotor, nacelle, blades and tower to be removed in the reverse construction and installation order.	Materials brought onshore to U.S. port for recycling and disposal; Steel in the tower is assumed to be recycled; and The blades are assumed to be recycled.
WTG Monopile Foundation	Removal of the monopiles is done using a reversed construction and installation method. Removal of the monopile is assumed to be cut off below the mud line and be lifted off by a heavy lift vessel (HLV) to a barge prior to decommissioning.	Monopile to be cut at or just below mudline and transported to U.S. port for recycling; and Steel is assumed to be recycled.
Offshore Substation topside	Removal of the Offshore Substation topside is done using a reversed construction and installation method. The Offshore Substation topside is assumed to be lifted off by a HLV to a barge prior to decommissioning.	Transported to U.S. port for recycling and disposal; and Steel from the topside is assumed to be recycled.
Offshore Substation Jacket Foundation	The Offshore Substation Jacket Foundation piles are assumed to be cut below the mud line, before the jacket is lifted off in one section by a HLV to a barge prior to decommissioning.	Cut below mudline and transported to U.S. port for recycling; and Steel from the jacket and piles is assumed to be recycled.

<b>Project Component</b>	<b>Removal Method</b>	<b>Comments and Assumptions</b>
Cables	The Offshore Export Cables and Inter-Array Cables are assumed to be lifted out and cut into pieces or reeled in.	Total removal of cable and transported to U.S. port for recycling; and Core material to be recycled.
Scour protection and rock filling	Alternatives: Removal of scour protection and rock filling; and Leave scour protection in place, as undisturbed as possible.	Assumed to be removed unless leaving in place is deemed appropriate through consultation with the appropriate authorities.

(Similar to Table 1-6 in BOEM’s BA and COP, Section 3.6; Dominion Energy 2023)

BOEM and BSEE would require Dominion Energy to submit a decommissioning application upon the earliest of the following dates: two years before the expiration of the lease, 90 days after completion of the commercial activities on the commercial lease, or 90 days after cancellation, relinquishment, or other termination of the lease (see 30 CFR 585.905). Upon completion of the technical and environmental reviews, BOEM and BSEE may approve, approve with conditions, or disapprove the lessee’s decommissioning application. This process would include an opportunity for public comment and deliberations with municipal, state, and Federal management agencies. Dominion Energy would need to obtain separate and subsequent approval from BSEE and BOEM to retire in place any portion of the proposed Project. Approval of such activities would require compliance under the National Environmental Policy Act and other Federal statutes and implementing regulations.

### 3.5 High-Resolution Geophysical (HRG) Surveys

Surveys using HRG equipment will be conducted prior to, during, and after construction. The HRG surveys use a combination of sonar-based methods to map shallow geophysical features. Data collected provides information to identify seafloor hazards, important resources, and to support micro-siting of the WTG and OSS foundations and all cable routes. Data is collected after construction to ensure that all underwater project components have been properly installed.

Dominion Energy anticipates the HRG surveys may utilize acoustic equipment such as multibeam echosounders, side scan sonars, shallow penetration sub-bottom profilers (SBPs) (e.g., Compressed High-Intensity Radiated Pulses (CHIRPs) non-parametric SBP), medium penetration sub-bottom profilers (e.g., sparkers and boomers), ultra-short baseline positioning equipment, and marine magnetometers. Representative survey equipment is identified in Table 8 that may be used during the CVOW-C project. The survey equipment is typically towed behind a moving survey vessel attached with a cable. HRG survey vessels move slowly, with typical operational speeds of approximately less than 4 knots.

**Table 8. HRG Acoustic Sources and their Operational Parameters**

<b>Equipment Classification</b>	<b>Representative Equipment</b>	<b>Operating Frequencies (kHz)</b>	<b>L<sub>p</sub></b>	<b>L<sub>p,pk</sub></b>	<b>Primary Beam Width (degrees)</b>	<b>Pulse Duration (millisecond)</b>
Subsea Positioning /	Sonardyne Ranger 2 USBL	35 - 55	188	191	90	1

ultra-short baseline (USBL)	EvoLogics S2CR	48 - 78	178	186	Horizontally Omnidirectional	500 - 600
	ixBlue Gaps	20 - 30	191	194	200	9 - 11
Multibeam Echosounder	R2Sonics 2026	170 - 450	191	221	0.45 x 0.45 - 1 x 1	0.015 – 1.115
Synthetic Aperture Sonar (SAS), combined bathymetry/ sidescan <sup>a</sup>	Kraken Aquapix	337	210	213	>135 vertical, 1 horizontal	1 - 10
Side Scan Sonar <sup>a</sup>	EdgeTech 4200 dual frequency	300 and 600	206 <sup>b</sup>	212 <sup>b</sup>	140	5 - 10
Parametric SBP	Innomar SES-2000 Medium 100	2 - 22	241	247	2	0.07 - 1
NonParametric SBP	EdgeTech 216 CHIRP	2 - 16	193	196	15 – 25	5 - 40
	EdgeTech 512 CHIRP	0.5 - 12	177 <sup>c</sup>	191 <sup>c</sup>	16 – 41	20
Medium Penetration Seismic	Geo Marine Dual 400 Sparker 800J	0.25 - 4	200 <sup>d</sup>	210 <sup>d</sup>	Omnidirectional	0.5 - 0.8
	Applied Acoustics S-Boom (Triple Plate Boomer 1000J)	0.5 - 3.5	203 <sup>e</sup>	213 <sup>e</sup>	60 <sup>f</sup>	10
Magnetometer (Towed)	Geometrics G882	200	192	190	7	1.13

(From MMPA Proposed Rule 88 FR 28656)

Note: dB re 1  $\mu$ Pa m – decibels referenced to 1 MicroPascal at 1 m; kHz – kilohertz

a - The operating frequencies of these sources are above all relevant marine mammal hearing thresholds (&gt;180 kHz) and are not expected to cause take by harassment of marine mammals.

b - The source level is based on data from Crocker and Fratantonio (2016) using the EdgeTech 4200 at 100% power and 100 kHz as a proxy.

c - The source level is based on data from Crocker and Fratantonio (2016) using the EdgeTech 512i at 100% power as a proxy.

d - The source level is based information provided by the source manufacturer in the supplemental attachment to the ITA application called “Noise Level Stacked 400 - tuned”

e - The source level is based on data from Crocker and Fratantonio (2016) using the Applied Acoustic S-Boom with CSP-N Energy Source set at 1,000 joules as a proxy.

f - The beam width is based on data from Crocker and Fratantonio (2016) using the Applied Acoustics S-Boom as a proxy.

The HRG surveys would utilize between two or three vessels working concurrently in different sections of the Lease Area and Export Cable Routes. All vessels would be operating several kilometers apart at any one time. On average, 58 km (36 mi) would be surveyed each survey day, per vessel, at a speed of approximately 2.4 km/hour (1.3 kts) on a 24-hour basis although some vessels may only operate during daylight hours (survey vessels operating for 12-hours). During the 5 years the proposed MMPA ITA would be effective an estimated area of 64,264 km<sup>2</sup> (24,812.5 mi<sup>2</sup>; 15,879,980.2 acres) will be surveyed across the CVOW-C project area.

HRG site characterization surveys would occur annually and throughout the five years of the proposed authorization with duration dependent on the activities occurring in that year (i.e., construction versus non-construction year). The purpose of surveying during non-construction years is to monitor seabed levels and scour protection, identify any risks to inter-array and export cable integrity, and conduct seabed clearance surveys prior to maintenance/repair.

The HRG survey schedule assumes 24-hour operations and does account for periods of potential downtime due to inclement weather or technical malfunctions. HRG surveys are anticipated to operate at any time of year for a maximum of 1,108 active sound source days (i.e., days in which an acoustic source would be used) over the five-year project. Up to 65 days are anticipated pre-construction, 307 are anticipated to occur during the primary construction years (2025 and 2026), and 736 would occur during the post-construction years. An approximated schedule for Dominion Energy's HRG survey effort is shown in Table 9. As Dominion Energy is not sure of the exact geographic locations of the survey effort, these values cannot be decisively broken up between the Lease Area and the Export Cable Routes. However, the values presented in Table 9 provide a comprehensive accounting by Dominion Energy of the total survey effort anticipated to occur annually.

**Table 9. Proposed HRG Survey Schedule for the CVOW-C Project**

Survey Segment	Year	Duration (Days) <sup>a</sup>
Pre-Lay Surveys	2024	65
As-Built Surveys and Pre-Lay Surveys	2025	249
As-Built Surveys	2026	58
Post-Construction Surveys	2027	368
Post-Construction Surveys	2028	368

(From MMPA Proposed Rule 88 FR 28656)

a - As multiple vessels (i.e., two survey vessels) may be operating concurrently across the project area, each day that a survey vessel is operating counts as a single survey day. For example, if two vessels are operating in one of the Export Cable Routes and one is operating in the Lease Area, but both are operating concurrently, this counts as two survey days.

### 3.6 Fisheries Monitoring Plans

Proposed activities for the CVOW-C project include research based surveys for Fisheries Monitoring. These Fisheries Monitoring Plans have been developed in consideration of both BOEM's guidelines for providing information on fisheries for offshore wind projects (BOEM 2019) and Responsible Offshore Science Alliance (ROSA) guidance for overarching principles and recommended elements for experimental protocols in the design and implementation of offshore wind monitoring projects (ROSA 2021).

### 3.6.1 Whelk Surveys

These surveys will acquire 2 years of pre-construction data at the Project Lease Area with a focus on whelk (*Busycon spp.*). Whelk surveys will use pots (traps) common to the whelk fisheries deployed and left at the fishing location and hauled at intervals (approximately 3 days), and then re-baited and set again. Sampling will occur twice a month during times of traditionally high fishing activity (November to March) and once a month during times of traditionally low fishing activity (April to October) (21 cruises [4 in year one and 17 in year two]). It is anticipated to deploy 8 strings of 12 pots. The approximate length of each trawl will be 1,800 ft (149 m) with 150 ft (45 m) spacing between the pots. Baited pots are weighted allowing them to remain on the seafloor. Typically, this fishery deploys single pots along the seafloor with static vertical buoy lines to mark the position at the surface. The pots for this study will be deployed in strings (or trawls) of multiple pots along the seafloor, which are connected by sinking groundlines. Ropeless (aka “on demand”) systems will be used for the duration of the study to reduce the potential for entanglement of a variety of nontarget species (e.g., marine mammals and sea turtles) by eliminating the need for static vertical buoy lines in the water column. A Global Positioning System (GPS) will be used to mark the location of deployed gear. Different technologies may be tested for recovery such as timed or acoustic release mechanisms for components to raise to the surface, or grappling for the groundlines as a secondary method of retrieval.

Two subareas within the Project Lease Area, composed of three turbine locations each, will be targeted throughout the whelk sampling study. These areas will be chosen based on examining relevant fishery, oceanographic and biological data, and through discussions between stakeholders and Dominion Energy. The two subareas will be stratified by depth, with one area less than 30 m and the second area greater than 30 m (Figure 7). One turbine within each of the two subareas will be randomly selected with four distance strata chosen from that turbine location. For each sampling event, pots will be deployed within a randomly chosen portion of each one of four distance strata (Figure 7). The first three distance strata will be informed by the literature. The fourth distance strata will be far enough from the turbine to be outside the Project Lease Area to function similarly as a control site where no turbine effect is anticipated.

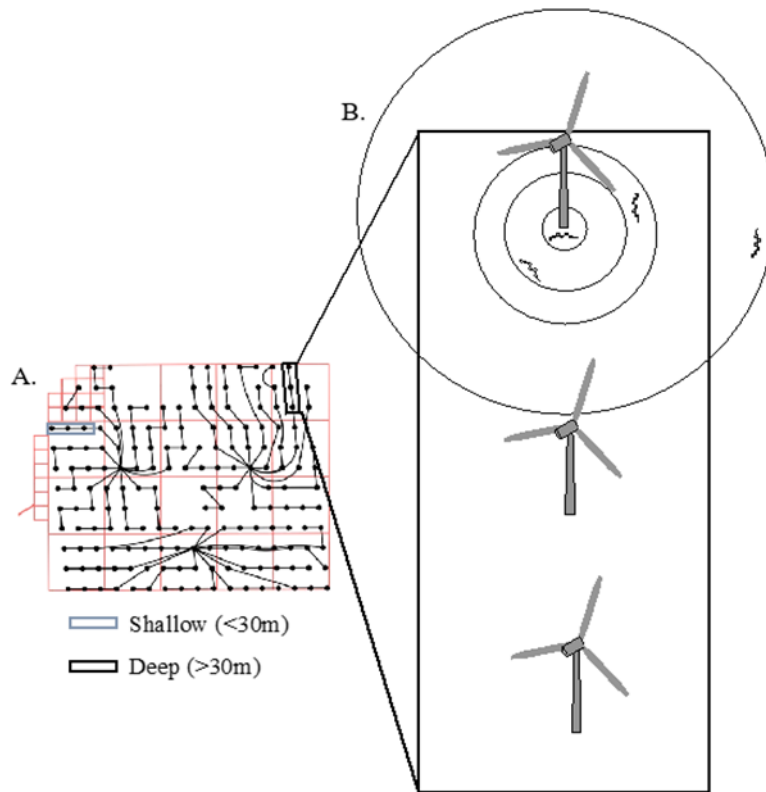

Figure 7. Representative turbine and cable array in A. Example of depth stratified subareas for fishery pot survey sites in B.

### 3.6.2 Black Sea Bass Surveys

These surveys will acquire 2 years of pre-construction data at the Project Lease Area with a focus on black sea bass (*Centropristes striata*). Sampling will be conducted with fish pots (traps) common in the black sea bass fishery that are typically deployed on strings (or trawls) of multiple pots along the seafloor, which are connected by sinking groundlines. Typically at the end of each string, there is a static vertical buoy line that is attached to mark the gear's position at the surface. Similar to the whelk surveys, (GPS) will be used to mark the location of deployed gear and ropeless (aka "on demand") systems will be used for the duration of the study to reduce the potential for entanglement of a variety of nontarget species (e.g., marine mammals and sea turtles) by eliminating the need for static vertical buoy lines in the water column.

Pots will be constructed so as to be consistent with regional efforts with respect to design elements of the gear (i.e., trap material, volume, entrance funnels, and escape vent configuration). It is anticipated to construct eight strings of six pots for deployment. The approximate length of each trawl will be 660 ft (201 m) including the anchor line, with 60 ft (18 m) spacing between the pots. In an effort to characterize both the underlying population demographics of the sampled black sea bass resource and the catches of the commercial fishery, a combination of ventless and vented (consistent with current regulatory requirements) pots randomly placed within a string will be utilized.

Sampling locations will be conducted in the same manner as the whelk surveys, with two subareas composed of three turbine locations, with one area less than 30 m and the second area greater than 30 m (Figure 7). These



areas will be chosen based on examining relevant fishery, oceanographic and biological data, and through discussions with stakeholders and Dominion Energy. For each sampling event, one turbine within each of the two subareas will be randomly selected with four distance strata chosen from that turbine location. The first three distance strata will be informed by the literature and other fishery monitoring studies for black sea bass in the region. The fourth distance strata will be farther from the turbine (outside of the Project Lease Area) to function similarly as a control site where no turbine effect is anticipated.

### **3.7 Minimization and Monitoring Measures that are part of the Proposed Action**

There are a number of measures that the CVOW-C project, through its COP, is proposing to take and/or BOEM is proposing to require as conditions of COP approval that are designed to avoid, minimize, or monitor effects of the action on ESA-listed species. For the purpose of this consultation, the mitigation and monitoring measures proposed by BOEM and/or USACE and identified in the BA as part of the action that BOEM is requesting consultation on are considered part of the proposed action. The MMPA ITA proposed by NMFS OPR includes a number of measures to avoid, minimize, or monitor effects, which are also considered as part of the proposed action for this consultation. The ITA only proposes mitigation and monitoring measures for marine mammals, which includes the threatened and endangered whales considered in this Opinion. It is worth noting that some measures in the proposed ITA, e.g., pile driving soft-start, may also reduce potential impacts to other listed species (turtles and fish). In addition to the conditions of the proposed ITA, the measures considered as part of the proposed action are as described in Table 1-7 and 1-8 in BOEM's BA and for ease of reference are copied into Appendix A of this Opinion. We note that the final MMPA ITA may contain measures that include requirements that may differ from the proposed rule; as explained in this Opinion's Incidental Take Statement (ITS), compliance with the conditions of the final MMPA ITA is necessary for the ESA take exemption to apply.

A fundamental strategy to reduce potential effects from underwater noise caused by foundation installations is through the use of a noise abatement system during pile driving. Dominion Energy proposes using near-to-pile noise mitigation systems such as the Hydro Sound Damper, the Noise Mitigation Sleeve, or the AdBm Noise Mitigation System; or far-from-pile noise mitigation systems, such as a double big bubble curtain (DBBC); or possibly both systems, to achieve, at minimum, a 10 dB noise reduction (Bellmann et al. 2020). The proposed MMPA ITA stipulates that if a single system is used, it must be a DBBC. Bubble curtain systems are compressed air systems that create air bubble barriers for sound absorption in water. Sound stimulation of air bubbles at or close to their resonance frequency effectively reduces the loudness of the radiated sound wave (i.e., the noise produced during pile driving) by means of scattering and absorption effects. The DBBC hoses will be deployed before the foundation installation vessel is in position. Two air hoses would be placed in a circular or elliptical shape at radii of approximately 591 ft (180 m) and 755 ft (230 m) from the monopile installation location. DBBCs will be pre-deployed at two to three foundation installation locations that are close to one another, recovered as soon as the piling is completed, and re-deployed at other foundation installation locations to reduce the number of times the curtain has to be moved. Approximately 125.9 to 148.1 acres (50.9 to 59.9 hectares) of sea floor will be temporarily disturbed during the DBBC installation and removal with the platform supply vessel.

BOEM has previously completed a programmatic ESA consultation with NMFS for OSW site assessment activities that includes HRG surveys (NMFS 2021f). As described in the CVOW-C project BA, BOEM will require CVOW-C to comply with all relevant programmatic survey and monitoring PDCs and BMPs included in the 2021 programmatic ESA consultation.

The proposed action includes clearance zones for whale and turtle species before initiating pile driving and shutdown zones during pile driving. More information is provided in the *Effects of the Action* section of this Opinion. These zones are summarized in Table 10. There will also be a minimum visibility requirement for pile driving; 1,750 m for pile driving foundations and 1,000 for pile driving goal posts was proposed in the BA. However, in the conditions of the proposed MMPA ITA, that zone size is increased to 2,000 m for WTG monopile and OSS pin pile installation. During all foundation installation, Dominion Energy must ensure that the entire minimum visibility zone (as based on the installation activity occurring) is visible ( i.e., not obscured by dark, rain, fog, etc.) for a full 60 minutes immediately prior to commencing vibratory or impact pile driving for foundation installation and 30 minutes for all other pile driving (trenchless installation). In addition, the entire clearance zone must be visually clear of marine mammals prior to commencing vibratory or impact pile driving. The clearance zone is the area around the pile that must be declared “clear” of marine mammals and sea turtles prior to the activity commencing. The size of the zone is measured as the radius with the impact activity (i.e., pile) at the center. For sea turtles, the area is “cleared” by visual observers determining that there have been no sightings of sea turtles in the identified area for a prescribed amount of time. For marine mammals, both visual observers and passive acoustic monitoring (PAM, which detects the sound of vocalizing marine mammals) will be used; the area is determined to be “cleared” when visual observers have determined there have been no sightings of marine mammals in the identified area for a prescribed amount of time and, for NARWs in particular, if no right whales have been visually observed in any area beyond the minimum clearance zone that the visual observers can see. Further, the PAM operator will declare an area “clear” if they do not detect the sound of vocalizing right whales within the identified PAM clearance zone for the identified amount of time. Pile driving cannot commence until all of these clearances are made.

Once pile driving begins, the shutdown zone applies. If a marine mammal or sea turtle is observed by a visual PSO entering or within the respective shutdown zones after pile driving has commenced, an immediate shutdown of pile driving will be implemented unless CVOW-C project personnel and/or its contractor determines shutdown is not feasible due to an imminent risk of injury or loss of life to an individual or risk of damage to a vessel that creates risk of injury or loss of life for individuals. For right whales, shutdown is also triggered by: the visual PSO observing a right whale at any distance (i.e., even if it is outside the shutdown zone identified for other whale species), and a detection by the PAM operator of a vocalizing right whale at any distance. There are two scenarios, approaching pile refusal and pile instability, where this imminent risk could be a factor. Pile refusal occurs when the pile driving sensors indicate the pile is approaching refusal, and a shutdown would lead to a stuck pile which then poses an imminent risk of injury or loss of life. Pile instability occurs when the pile is unstable and unable to stay standing if the piling vessel were to “let go.” During these periods of instability, the lead engineer may determine a shutdown is not feasible because the shutdown combined with impending weather conditions may require the piling vessel to “let go”, which then poses an imminent risk of injury or loss of life. In any of these situations, if a shutdown is called for but the lead engineer determines shutdown is not feasible due to risk of injury or loss of life, then hammer energy must be reduced. BOEM and CVOW-C anticipate a low likelihood of occurrence for the pile refusal/stuck pile or pile instability scenario.

**Table 10. Proposed clearance and exclusion zones.<sup>8</sup>**

Species	Clearance Zone (m)	Shutdown Zone (m)
---------	--------------------	-------------------

<sup>8</sup> Note that these are in addition to the minimum visibility zone of 1,750 m for WTG and OSS foundation installation and 1,000 m for goal post installation.

<b>Impact Pile Driving of Foundations</b>		
NARW – visual detection	Minimum visibility zone plus any additional distance observable by the visual PSOs	Minimum visibility zone plus any additional distance observable by the visual PSOs
NARW – Passive Acoustic Monitoring (PAM)	any distance	any distance
Fin, Sei, and Sperm Whale – WTG	5,100 <sup>a</sup>	1,750
Sea Turtles	1,000	100
<b>Vibratory Pile Driving of Foundations or Cofferdams</b>		
NARW- visual detection	any distance	any distance
Fin, Sei, and Sperm Whale	1,000	1,000
Sea Turtles	1,000	100
<b>Impact Pile Driving of Goal Post Piles</b>		
NARW - visual detection	any distance	any distance
Fin, Sei, and Sperm Whale	1,000	1,000
Sea Turtles	1,000	100
<b>HRG Surveys</b>		
NARW - visual detection	500	500
Fin, Sei, and Sperm Whale	500	500
Sea Turtles	500	100

<sup>a</sup> Distance for a one pile per day scenario. The two pile per day scenario is 6,500 m. All other categories have the same values for either one or two piles per day.

### **3.8 MMPA Incidental Take Authorization (ITA) Proposed for Issuance by NMFS**

In response to their application, NMFS OPR has proposed to issue the CVOW-C project an ITA for the take of small numbers of marine mammals incidental to construction of the project with a proposed duration of five years. More information on the proposed Incidental Take Regulation ITR and associated LOA, including Dominion Energy’s application is available online (<https://www.fisheries.noaa.gov/action/incidental-take-authorization-dominion-energy-virginia-construction-coastal-virginia>). As described in the Notice of Proposed Rule (88 FR 28656; May 4, 2023), take of marine mammals may occur incidental to the construction of the project due to in-water noise exposure resulting from Project activities likely to result in incidental take including pile driving (impact and vibratory) and vessel-based site assessment surveys using high-resolution geophysical (HRG) equipment

### 3.8.1 Amount of Take Proposed for Authorization

The proposed ITA would be effective for a period of five years, and, if issued as proposed, would authorize Level A and Level B harassment as the only type of take expected to result from activities during the construction phase of the project. Section 3(18) of the Marine Mammal Protection Act defines “harassment” as any act of pursuit, torment, or annoyance, which (i) has the potential to injure a marine mammal or marine mammal stock in the wild (Level A harassment); or (ii) has the potential to disturb a marine mammal or marine mammal stock in the wild by causing disruption of behavioral patterns, including, but not limited to, migration, breathing, nursing, breeding, feeding, or sheltering (Level B harassment). It is important to note that the MMPA definition of harassment is not the same as harassment under the ESA. This issue is discussed in further detail in the *Effects of the Action* section of this Opinion.

The methodology for estimating marine mammal exposure and incidental take is described fully in the Notice of Proposed ITA and discussed further in the *Effects of the Action*. For the purposes of the proposed ITA, NMFS OPR estimated the amount of take by considering: (1) acoustic thresholds above which NMFS OPR determined the best available scientific information indicates marine mammals will be behaviorally harassed or incur some degree of permanent hearing impairment; (2) the area or volume of water that will be ensonified above these levels in a day; (3) the density or occurrence of marine mammals within these ensonified areas; and, (4) the number of days of activities. NMFS OPR is proposing to authorize MMPA take of ESA-listed species due to noise exposure from impact pile driving for foundation installations, and HRG surveys (see Table 11).

**Table 11. Total Take of ESA-Listed Species by Level A Harassment and Level B Harassment Proposed for Authorization through the MMPA ITA.**

Species	Total	
	Level A	Level B
North Atlantic Right Whale	0	17
Fin Whale	7	208
Sei Whale	2	8
Sperm Whale	0	6

As described in the Notice of Proposed ITA, modeling was completed to estimate the sound fields associated with a number of noise producing activities and to estimate the number of individuals likely to be exposed to noise above identified thresholds. Table 12 shows the proposed take to be authorized resulting from vibratory and impact pile driving associated with 183 WTG (assumes 183 monopile installation events and 176 WTGs installed) and 3 OSS Total Installation impact pile driving, all assuming 10 dB attenuation (as required by conditions of the proposed ITA). The number of Level A and Level B takes proposed to be authorized for NARW, fin, sei, and sperm whales varies by species and, as noted, applies only to pile driving for WTG and OSS. No take resulting from goal post pile driving or cofferdam installation and removal is proposed to be authorized. Only Level B take is proposed to be authorized for HRG surveys (Table 13).

**Table 12. Take of ESA-Listed Species by Level A and B Harassment Proposed for Authorization through the MMPA ITA Resulting from Vibratory and Impact Pile Driving of WTG and OSS Foundations**

Species	Total	
	Level A	Level B
North Atlantic Right Whale	0	12
Fin Whale	7	202
Sei Whale	2	5
Sperm Whale	0	6

**Table 13. Take of ESA-Listed Species by Level B Harassment Proposed for Authorization through the MMPA ITA Resulting from HRG Surveys.**

Species	Level B
North Atlantic Right Whale	5
Fin Whale	5
Sei Whale	3
Sperm Whale	0

### 3.8.2 Mitigation Measures Included in the Proposed ITA

The proposed ITA includes a number of minimization and monitoring methods that are designed to ensure that the proposed project has the least practicable adverse impact upon the affected species or stocks and their habitat and would be required to be implemented by the CVOW-C project. The proposed ITA, inclusive of the proposed mitigation requirements, has been published in the Federal Register (88 FR 28656). The proposed mitigation measures include restrictions on pile driving, establishment of clearance zones, shutdown measures, soft-start of pile driving, ramp up of HRG sources, noise mitigation for impact pile driving, and vessel strike avoidance measures. For the purposes of this section 7 consultation, all minimization and monitoring measures included in the ITA proposed by NMFS OPR are considered as part of the proposed action for this consultation. We note that some of the measures identified here overlap or are duplicative with the measures described by BOEM in the BA as part of the proposed action (Appendix A as referenced above). The mitigation measures included in the May 2023 Proposed ITA are listed in Appendix B.

### 3.9 Action Area

The action area is defined in 50 CFR 402.02 as “all areas to be affected directly or indirectly by the Federal action and not merely the immediate area involved in the action.” Effects of the action “are all consequences to listed species or critical habitat that are caused by the proposed action, including the consequences of other activities that are caused by the proposed action. A consequence is caused by the proposed action if it would not occur but for the proposed action and it is reasonably certain to occur. Effects of the action may occur later in time and may include consequences occurring outside the immediate area involved in the action.”

The action area includes the WDA (see Figure 1) where construction, operations and maintenance, and decommissioning activities will occur and the surrounding areas ensounded by noise from project activities; the cable corridors; and the areas where HRG and biological resource surveys will take place. Additionally, the action area includes the US EEZ along the Atlantic and Gulf coasts; this includes the vessel transit routes between the WDA and ports in Virginia; and the routes used by vessels transporting manufactured components from ports in the Gulf of Mexico to the project site.

BOEM and Dominion Energy have described vessel transits from ports in eastern Canada and Europe, including approximately 102 round trips to/from overseas ports in Nova Scotia, Canada for the fall pipe vessel, 3 cycles of 1 HLV for transporting jackets from European ports to the installation site, and use of 1 DP HLV for jacket installation to/from Europe. These trips could occur at some time during the 2-year construction phase. The amount of these transits is likely to be substantially less than from domestic ports but the specific amount of these trips is currently not known. The ports that vessels will originate from in Canada and Europe, and the vessel routes from those port facilities to the project site are unknown and will be variable and depend, on a trip-by-trip basis, on weather and sea-state conditions, other vessel traffic, and any maritime hazards. These vessels are expected to enter the US EEZ along the Atlantic Coast and then travel along established traffic lanes and fairways until they approach the lease area. Because the ports of origin and vessel transit routes are unknown, we are not able to identify what areas outside the US EEZ will be affected directly or indirectly by the Federal action; that is, while we recognize that there will be vessel trips outside of the US EEZ that would not occur but for the approval of CVOW-C’s COP, we cannot identify what areas vessel transits will occur as a result of BOEM’s proposed approval of CVOW-C’s COP. Though these vessel transits may be caused by the proposed action, without specific information including the ports of origin, and the location, timing and routes of vessel transit, we cannot predict that specific consequences of these activities on listed species<sup>9</sup> are reasonably certain to occur, and they are therefore not considered effects of the proposed action (50 CFR 402.17[a]-[b]). Therefore, the action area is limited to the US EEZ off the Gulf and Atlantic coasts of the United States.

## 4 SPECIES AND CRITICAL HABITAT NOT LIKELY TO BE ADVERSELY AFFECTED

NMFS uses two criteria to identify ESA-listed species and critical habitats that are not likely to be adversely affected by the Federal agency’s proposed action, as well as the effects of activities that are consequences of the proposed action. The first criterion is exposure, or some reasonable expectation of physical co-occurrence, between 1 or more potential stressors associated with the proposed activities and ESA-listed species or

---

<sup>9</sup> In an abundance of caution, we have considered the risk that these vessel trips may pose to ESA-listed species that may occur outside the US EEZ. We have determined that these species fall into two categories: (1) species that are not known to be vulnerable to vessel strike and therefore, we would not expect a project vessel to strike an individual regardless of the location of the vessel; or (2) species that may generally be vulnerable to vessel strike but outside the US EEZ, co-occurrence of project vessels and individuals of those ESA-listed species are expected to be extremely unlikely due to the seasonal distribution and dispersed nature of individuals in the open ocean, and intermittent presence of project vessels. These factors make it extremely unlikely that there would be any effects to ESA-listed species from the operation of project vessels outside the EEZ.

designated critical habitat. If we conclude that an ESA-listed species or designated critical habitat is not likely to be exposed to the proposed activities, we must also conclude that the species or critical habitat is not likely to be adversely affected by those activities.

The second criterion is the probability of a response given exposure. ESA-listed species or designated critical habitat that co-occur with a stressor of the action but are not likely to respond to the stressor are also not likely to be adversely affected by the proposed action.

The probability of an effect on a species or designated critical habitat is a function of exposure intensity and susceptibility of a species to a stressor's effects (i.e., probability of response). An action warrants a "may affect, not likely to be adversely affected" finding when its effects are wholly beneficial, insignificant or discountable. Beneficial effects have an immediate positive effect without any adverse effects to the species or habitat.

*Insignificant* effects relate to the size or severity of the impact and include those effects that are undetectable, not measurable, or so minor that they cannot be meaningfully evaluated. Insignificant is the appropriate effect conclusion when plausible effects are going to happen, but will not rise to the level of constituting an adverse effect. *Discountable* effects are those that are extremely unlikely to occur. For an effect to be discountable, there must be a plausible adverse effect (i.e., a credible effect that could result from the action and that would be an adverse effect if it did impact an ESA-listed species), but it is very unlikely to occur.

In the subsections that follow, we evaluate the likelihood of effects from the proposed action's potential stressors to ESA-listed and proposed species or designated and proposed critical habitat that may be affected, but are not likely to be adversely affected by the proposed action.

In the BA (see BA Section 2.3 and edited Table 4-1), BOEM concludes that the proposed action is not likely to adversely affect the blue whale, Rice's whale, Gulf of Maine DPS of Atlantic salmon, oceanic whitetip shark, scalloped hammerhead shark, shortnose sturgeon, hawksbill sea turtle, and giant manta ray. BOEM also concludes that the proposed action is not likely to adversely affect critical habitat designated for NARWs, critical habitat for all listed DPSs of Atlantic sturgeon, and critical habitat in the Gulf of Mexico. We concur with BOEM's determination that the proposed action is not likely to adversely affect these species and critical habitat, as discussed below, as well as conclude that Gulf sturgeon are not likely to be adversely affected by the action; we conclude consultation informally for these species and critical habitat designations. BOEM concluded the project was not likely to adversely affect Atlantic sturgeon. NMFS does not concur with this determination and completed an analysis of the stressors we determined are likely to adversely affect these species. Effects to fin whales, NARWs, sei whales, sperm whales, green sea turtles, leatherback sea turtles, loggerhead sea turtles, Kemp's ridley sea turtles, and Atlantic sturgeon are addressed in Section 7.0 of this Opinion.

#### **4.1 Blue Whale (*Balaenoptera musculus*)**

Blue whales are known to occur offshore of Virginia but are not expected to occur in the project area due to the location of preferred habitat outside the lease area and export cable routes, based on the best available information. They typically occur in deeper, offshore areas, and data suggest they are rare in the U.S. Mid-Atlantic shelf due to preference for high latitude feeding areas (Hayes et al. 2020; Lesage et al. 2017; Pike et al. 2009). Blue whale distribution is driven largely by food requirements; blue whales are more likely to occur in waters with dense concentrations of their primary food source, krill. While they can be found in coastal waters, they are thought to prefer waters further offshore. In the North Atlantic Ocean, the blue whale range extends from the subtropics to the Greenland Sea. They are most frequently sighted in waters off eastern Canada with a majority of sightings taking place in the Gulf of St. Lawrence. Blue whales do not regularly occur within the

U.S. EEZ and typically occur further offshore in areas with depths of 100 m or more (Waring et al. 2010). Blue whales were not observed during HRG surveys conducted by Dominion Energy in and around Virginia from 2018–2021 based on monitoring reports received for previously issued high-resolution site characterization IHAs (85 FR 55415, September 8, 2020; 85 FR 81879, December 17, 2020; 86 FR 21298, April 22, 2021), for the construction of the CVOW Pilot Project (85 FR 30930, May 21, 2020) or Unexploded Ordnance/Munitions and Explosives of Concern (UXO/MEC)-specific surveys (83 FR 39062, August 8, 2018). Blue whales have not been documented in the WDA<sup>10</sup> and are not expected to occur in the WDA. Therefore, based on the best available information cited herein, which supports a conclusion that blue whales are extremely unlikely to occur in the WDA, we conclude that blue whales are extremely unlikely to be exposed to any effects of project activities in the WDA (e.g., foundation and cable installation); therefore, effects of those activities, including construction, operations, and decommissioning, inclusive of associated surveys, are discountable.

Based on their distribution, the only project activity blue whales could be exposed to is vessel operation in offshore portions of the U.S. EEZ as they travel between the WDA and Canadian or European ports. BOEM and Dominion Energy anticipate approximately 102 round trips to/from overseas ports in Nova Scotia, Canada for the fall pipe vessel, 3 cycles of 1 HLV for transporting jackets from European ports to the installation site, and use of 1 DP HLV for jacket installation to/from Europe. There are recorded sightings of blue whales in the northern portion of the transit route from ports in Canada that may be used during the construction phase. The rarity of observations in this area is consistent with the conclusion in Waring et al. (2010) that the blue whale is at most considered as an occasional visitor in the U.S. Atlantic EEZ waters and would be rare along the vessel transit route from Canada. Given the limited number and frequency of project vessel transits to/from Canada and Europe, and low numbers and dispersed nature of blue whales in this area, it is extremely unlikely that any blue whales will co-occur with project vessels. As such, effects to blue whales from vessel operations are also extremely unlikely to occur and effects are discountable. No take is anticipated. As all effects of the proposed action will be discountable, the proposed action is not likely to adversely affect the blue whale.

#### **4.2 Rice's Whale (*Balaenoptera ricei*)**

Rice's whale distribution is limited to the Gulf of Mexico. Rosel (2021) reported that based on a compilation of sighting and stranding data from 1992 to 2019, the primary habitat of the Rice's whale is the northeastern Gulf of Mexico, particularly the De Soto Canyon area. Core distribution area and proposed critical habitat incorporate the areas of known Rice's whale occurrence and are useful to assess potential overlap between Rice's whales and project vessels (88 FR 47453, Kiszka et al. 2023; Rosel 2021; Soldevilla et al. 2022). Rice's whale core distribution area occurs off the coast of Alabama and Florida in the eastern Gulf of Mexico, between 100 m and 400 m deep from approximately Pensacola, Florida to Mobile Bay, Alabama (84 FR 15446, 04/15/2019). Rice's whale critical habitat is proposed between the 100 and 400-m isobaths in the northern Gulf of Mexico (88 FR 47453, 07/24/2023). The majority of sightings are confined to the northeastern Gulf of Mexico; however, it is possible the species had a broader distribution.

The only overlap between Rice's whale and the proposed action area would be from vessels transiting from the Gulf of Mexico to the project area. If vessels transit from Texas or Louisiana, their transit routes would not be expected to overlap with Rice's whale core habitat; however, vessels transiting from any Gulf of Mexico port would cross within the 100-m to 400m depths of proposed critical habitat. Only a single vessel trip from the Gulf of Mexico is anticipated as Dominion Energy has commissioned the construction of a purpose built offshore wind support vessel from a manufacturer in Texas.

---

<sup>10</sup> Available sightings data at: <http://seamap.env.duke.edu/species/180528>. Last accessed September 13, 2023.



All vessels would adhere to vessel strike avoidance measures, including use of observers to maintain the 100-m separation distance from any sighted ESA-listed whale and compliance with speed restrictions. Considering there is only one vessel transit from a port in the Gulf of Mexico as a part of the proposed action, and the measures to observe and avoid vessel strike, it is extremely unlikely that the Rice's whale would be affected by vessel strike and, therefore, it is discountable. We conclude that this action may affect, but is not likely to adversely affect Rice's whale.

#### **4.3 Atlantic Salmon (*Salmo salar*) - Gulf of Maine DPS**

The only remaining populations of Gulf of Maine DPS Atlantic salmon are in Maine. Smolts migrate from their natal rivers in Maine north to foraging grounds in the Western North Atlantic off Canada and Greenland (Fay et al. 2006). After 1 or more winters at sea, adults return to their natal river to spawn. Atlantic salmon do not occur in the lease area or along the cable corridors or in the portion of the action area that will experience increased noise during project construction, operations, or decommissioning or where surveys will occur.

Atlantic salmon in the action area would only be encountered during vessel transits from ports in Europe and Nova Scotia, Canada. However, the likelihood of Project vessels encountering Atlantic salmon in the Gulf of Maine during transits is low since vessel strikes are not often reported for this species. There is no evidence of interactions between vessels and Atlantic salmon, and vessel strikes are not identified as a threat in the listing determination (74 FR 29344) or the recent recovery plan (NMFS and USFWS 2019). Atlantic salmon migrate at depths below the draft of project vessels. Vessel transits would not disturb any freshwater habitats where spawning occurs. The potential for Atlantic salmon to be exposed to vessel noise or vessel strikes is extremely unlikely, and therefore discountable. Therefore, Atlantic salmon are not likely to be adversely affected by the proposed action.

#### **4.4 Oceanic Whitetip Shark (*Carcharhinus longimanus*)**

In the western Atlantic, the oceanic whitetip shark is distributed worldwide in tropical and subtropical waters, usually found in open ocean and near the outer continental shelf, including the Caribbean and Gulf of Mexico (Young et al. 2018; Young and Carlson 2020). This highly migratory species is usually found offshore in the open ocean, on the outer continental shelf, or around oceanic islands (Bonfil et al. 2008; Young et al. 2018). Oceanic whitetip sharks can be found at the water's surface, but most frequently stay between 25.5 to 50 m (83.7 to 164 ft) depth (Young et al. 2018). In the Western Atlantic Ocean, oceanic whitetip sharks occur from Maine to Argentina, including the Caribbean Sea and Gulf of Mexico.

Although oceanic whitetip sharks could potentially interact with the proposed activities, these sharks are typically found farther offshore and in deeper water than the proposed study area. There have not been any observed interactions between the commercial fisheries covered by the Northeast Fisheries Science Center (NEFSC) Observer Program and oceanic whitetip sharks since the beginning of the program in 1989. There were 56 records of oceanic whitetip sharks in the Gulf of Mexico from 1975 through 1995 caught by commercial longline vessels as part of the NMFS Southeast Fisheries Science Center Pelagic Longline Observer Program (Kohler et al. 1998). All records are for captures beyond 200 m depth (656.2 ft), the majority of which were mature-sized individuals near the 2,000 m (6,568.17 ft) bathymetry line within Federal waters of the Gulf of Mexico out to the Exclusive Economic Zone of the U.S.

Most project activities are shoreward of the typical water depth range for this species. The lease area and cable corridors, as well as the area where noise from project construction, operation, and decommissioning, and where survey activities will occur is outside of the deep offshore areas where oceanic whitetip sharks occur. The only portion of the action area that overlaps with their distribution is the open ocean waters that may be

transited by vessels from Europe. Vessel strikes are not identified as a threat in the status review (Young et al. 2018), listing determination (83 FR 4153) or the recovery outline (NMFS 2018b). Considering the lack of any reported vessel strikes, their swim speed and maneuverability (Papastamatiou et al. 2018), and the slow speed of ocean-going vessels, vessel strikes are extremely unlikely even if migrating individuals occur along the vessel transit routes.

The likelihood that the proposed action would interact with oceanic whitetip sharks is extremely unlikely to occur, and thus discountable. Therefore, we conclude that this action may affect, but is not likely to adversely affect oceanic whitetip sharks.

#### **4.5 Scalloped Hammerhead Shark (*Sphyrna lewini*)**

Scalloped hammerhead sharks (*Sphyrna lewini*) is a circumglobal, highly mobile species that lives in coastal warm temperate and tropical seas and occurs over continental and insular shelves, as well as adjacent deep waters (NMFS 2020d). Scalloped hammerhead individuals from the Eastern Atlantic DPS (which includes the eastern Atlantic and Mediterranean Sea) and the Central and Southwest Atlantic DPS (the western Atlantic as far north as central Florida, as well as the Caribbean and waters off the east coast of South America) may occur in the action area but are not expected to occur within the project area. The Northwest Atlantic and Gulf of Mexico DPS, whose distribution encompasses the project area, is not listed under the ESA (79 FR 38213). ESA-listed scalloped hammerhead sharks in the action area would only be encountered by vessel transits to and from Europe and the Gulf of Mexico. Due to the number of vessels transiting from Europe and the Gulf of Mexico, and the degree of spatial overlap between transit routes and DPS ranges, the potential for listed scalloped hammerhead sharks to be exposed to vessel noise or vessel strikes is extremely unlikely, and therefore discountable. Therefore, scalloped hammerhead sharks are not likely to be adversely affected by the proposed action.

#### **4.6 Shortnose Sturgeon (*Acipenser brevirostrum*)**

Shortnose sturgeon are benthic fish that mainly occupy the deep channel sections in large coastal rivers of eastern North America. They range from as far south as the St. Johns River, Florida (possibly extirpated from this system) to as far north as the Saint John River in New Brunswick, Canada. Shortnose sturgeon are believed to spend most of their lives in their natal rivers, but occasionally migrate relatively short distances along the coast. Shortnose sturgeon are considered an amphidromous fish species which migrates between fresh and saltwater. Unlike anadromous and catadromous fish, which migrate explicitly for the purposes of breeding, amphidromous fish migrate for other purposes such as feeding. During their coastal migrations, they tend to stay nearshore and enter neighboring river systems as they move (Bemis and Canard 1997; SSSRT 2010). These movements are generally limited by geographic distance between river mouths, with greater movement between geographically proximate rivers. Movement between larger groups of rivers at greater geographic distance rarely occurs (King et al. 2001; Kynard et al. 2000). When coastal migrations have been documented, shortnose sturgeon do not appear to spend significant time in the marine environment and generally stay close to shore (Altenritter et al. 2018).

Based on the best available information, we consider it extremely unlikely that the proposed activities would interact with shortnose sturgeon. Within the Mid-Atlantic Region, shortnose sturgeon are found in Chesapeake Bay and populations in the Delaware River and the Potomac River, both of which are outside the action area (Kynard et al. 2016). Shortnose sturgeon do not occur in the lease area, and therefore would not be exposed to impacts limited to the project area (e.g., ensonified areas). If some shortnose sturgeon move from 1 river to another and overlap with part of the action area (including cable corridor and vessel transit routes), any effects of the action on shortnose sturgeon would be extremely unlikely. Coast movements of shortnose sturgeon are

rare in light of genetic differentiation, the paucity of tagged fish discovered outside their usual river systems, and a physiology-based avoidance of marine waters. Vessel strikes are also considered extremely unlikely to occur. Shortnose sturgeon are primarily demersal, occupying the bottom of the water column, and would rarely be at risk from moving vessels, which need sufficient water to navigate without encountering the bottom (NMFS 2021d). Given the species distribution, there is very limited potential overlap with the small number of vessels participating in the proposed action considered in this Opinion.

In summary, given the extremely low abundance of shortnose sturgeon within the action area and the extremely unlikely (i.e., discountable) co-occurrence with stressors associated with the proposed action, we conclude that the proposed action may affect, but is not likely to adversely affect shortnose sturgeon.

#### **4.7 Gulf Sturgeon (*Acipenser oxyrinchus desotoi*)**

The Gulf sturgeon is an anadromous fish found in riverine, estuarine, and nearshore marine environments of coastal states along the Gulf of Mexico. Adult Gulf sturgeon occupy freshwater during the warm months, which is when spawning occurs, and migrate into estuarine and marine waters in the fall to forage and overwinter. Historically, Gulf sturgeon occurred from the Mississippi River east to Tampa Bay. Their present range extends from Lake Pontchartrain and the Pearl River system in Louisiana and Mississippi, respectively, east to the Suwannee River in Florida. When in open waters of the Gulf of Mexico, sturgeon are generally thought to remain near the shoreline, although factors such as water depth or prey distribution may be more important than distance from land. For example, Gulf sturgeon have been observed off the Suwannee River area as far as 9 NM (16.7 km) from shore (67 FR 39105).

The only overlap between Gulf sturgeon occurrence and the action area would be vessels transiting from ports in the Gulf of Mexico. Gulf sturgeon would not occur in the project area. Only a single vessel trip from the Gulf of Mexico is anticipated as Dominion Energy has commissioned the construction of a purpose built offshore wind support vessel from a manufacturer in Texas. Considering there is only one vessel transit from a port in the Gulf of Mexico considered part of the proposed action, the likelihood of Gulf sturgeon being affected by vessel strike is discountable and, therefore, are not likely to be adversely affected.

#### **4.8 Hawksbill Sea Turtle (*Eretmochelys imbricata*)**

The hawksbill sea turtle is typically found in tropical and subtropical regions of the Atlantic, Pacific, and Indian Oceans, including the coral reef habitats of the Caribbean and Central America. Hawksbill turtles generally do not migrate north of Florida and their presence north of Florida is rare (NMFS and USFWS 1993). Hawksbill sea turtles are rarely observed in the Gulf of Mexico, with Florida and Texas being the only Gulf States with regular sightings (Hildebrand 1983; Keinath et al. 1991; Lee and Palmer 1981; NMFS and USFWS 1993; Parker 1995; Plotkin 1995; Rabalais and Rabalais 1980; Rester and Condrey 1996; Witzell 1983). Two records of Atlantic hawksbill sea turtles have been reported offshore Virginia (Keinath et al. 1991; Lockhart et al. 2014). Given their rarity in waters north of Florida, hawksbill sea turtles are highly unlikely to occur in the project area in the mid-Atlantic.

In the action area, hawksbill sea turtles would be most likely to be encountered by vessels transiting between the project area and ports in the Gulf of Mexico. Hawksbill sea turtles regularly occur in the Gulf of Mexico and the southeastern U.S. Atlantic coast, particularly off the coasts of southern Florida and Texas (NMFS and USFWS 1993). Considering there is only one vessel transit from a port in the Gulf of Mexico and observers will be used to maintain vessel separation distances (50 m for sea turtles), the likelihood of hawksbill turtles being affected by vessel strikes are discountable, and the proposed action is not likely to adversely affect the hawksbill sea turtle.

#### 4.9 Giant Manta Ray (*Manta birostris*)

The giant manta ray inhabits temperate, tropical, and subtropical waters worldwide, primarily between 35° N and 35° S latitudes. In the western Atlantic Ocean, this includes waters off South Carolina south to Brazil and Bermuda. Giant manta rays also occur in the Gulf of Mexico. On the U.S. Atlantic coast, nearshore distribution is limited to areas off the Florida coast; otherwise, distribution occurs in offshore waters at the shelf edge. Giant manta rays are commonly found offshore in oceanic waters, but are sometimes found feeding in shallow waters (less than 10 m) during the day (Lawson et al. 2017; Miller and Klimovich 2017). Giant manta rays can dive to depths of over 1,000 m, and also conduct night descents to between 200 and 450 m deep (Miller and Klimovich 2017). Giant manta rays frequently feed in waters 656 to 1,312 ft (200 to 400 m) in depth (NMFS 2019c). The species has also been observed in estuarine waters, oceanic inlets, and within bays, estuaries, and intercoastal waterways in the southern U.S. and Gulf of Mexico (Farmer et al. 2022).

Occasionally, manta rays are observed as far north as Long Island (Farmer et al. 2021; Miller and Klimovich 2017); however, these sightings are in offshore waters along the continental shelf edge, and the species is considered rare in waters north of Cape Hatteras. Distribution of giant manta rays is limited by their thermal tolerance and influenced by depth. Off the U.S. East Coast, giant manta rays are commonly found in waters from 66 to 72°F (19 to 22°C) from Florida to the Carolinas, whereas those off the Yucatan peninsula and Indonesia are commonly found in waters between 77 to 86°F (25 to 30°C, Farmer et al. 2022). Cold winter air and sea surface temperatures in the western North Atlantic Ocean likely create a physiological barrier to manta rays that restricts the northern boundary of their distribution (Farmer et al. 2021).

Giant manta rays are regularly sighted within the Mid-Atlantic during standardized surveys. Giant manta rays are most commonly detected in nearshore or shelf-edge habitats, and in productive areas, as identified by thermal fronts, bathymetric slope, and high chlorophyll-a concentration (Farmer et al. 2022). Farmer et al. (2022) predicted the highest occurrence north of Cape Hatteras during warmer months when sea temperatures are highest (May to October). For the lease area, species distribution models in Farmer et al. (2022) predict potential giant manta ray occurrence during May to October, while nearly zero probability of occurrence during other months; however, the authors note that while their models predicted high concentrations of manta rays in Chesapeake and Delaware Bays, there are no reported sightings in these areas and the prediction is likely confounded by high chlorophyll a concentrations (Farmer et al. 2022). SEAMAP data from numerous databases substantiates that sightings and density of giant manta ray are low in the lease area; most sightings are farther offshore and beyond where effects specific to the project area (e.g., noise) would occur (Barco 2014; Barco 2015a; Barco 2015b; Halpin et al. 2009; Kenney 2013; Mallette S. and Barco 2017; Mallette et al. 2016; McLellan 2016a; McLellan 2016b; McLellan 2017).

Giant manta rays occur in the action area; however, based on the documented distribution of the species, giant manta rays are not anticipated to occur in the lease area or in areas that will experience project noise. The only portion of the action area that overlaps with the distribution of Giant manta rays are the vessel transit routes to the south and where vessels travel across the continental shelf edge.

Giant manta rays can be frequently observed traveling just below the surface and will often approach or show little fear toward humans or vessels (Coles 1916), which may also make them vulnerable to vessel strikes (Deakos 2010). Vessel strikes can injure or kill giant manta rays, decreasing fitness or contributing to non-natural mortality (Couturier et al. 2012; Deakos et al. 2011). However, vessel strikes are considered rare. Information about interactions between vessels and giant manta rays is limited. The geographic area considered to have the highest risk of vessel strikes for giant manta ray is nearshore coastal waters and inlets along the east coast of Florida where recreational vessel traffic is concentrated; vessels transiting from the project area to the Gulf of Mexico would not be expected to overlap with this area nearshore. Given the few instances of

confirmed or suspected strandings of giant manta rays attributed to vessel strike injury, the risk of giant manta rays being struck by vessels is considered low. This lack of documented mortalities could also be the result of other factors that influence carcass detection (i.e., wind, currents, scavenging, decomposition etc.); however, giant manta rays appear to be able to be fast and agile enough to avoid most moving vessels, as anecdotally evidenced by videos showing rays avoiding interactions with high-speed vessels (Barnette 2018). The speed and maneuverability of giant manta rays, the dispersed nature of giant manta ray distribution in the open ocean area where these vessels will operate, and the implementation of vessel strike avoidance measures make any vessel strike effects of the proposed action extremely unlikely to occur.

#### 4.10 North Atlantic Right Whale Critical Habitat

Critical habitat for NARWs was designated in 1994 and expanded in 2016 (81 FR 4837). Presently, NARW designated critical habitat includes 2 major units: Unit 1 which is located in the Gulf of Maine and Georges Bank Region, and Unit 2 which is located off the coast of North Carolina, South Carolina, Georgia, and Florida. Units 1 and 2 are both outside the project area, but within the action area. The only project activity that would overlap with right whale critical habitat is the potential transit of project vessels from Canada (Unit 1) or the Gulf of Mexico (Unit 2).

As identified in the final rule (81 FR 4837), the physical and biological features essential to the conservation of the NARW that provide foraging area functions in Unit 1 are: The physical oceanographic conditions and structures of the Gulf of Maine and Georges Bank region that combine to distribute and aggregate *C. finmarchicus* for right whale foraging, namely prevailing currents and circulation patterns, bathymetric features (basins, banks, and channels), oceanic fronts, density gradients, and temperature regimes; low flow velocities in Jordan, Wilkinson, and Georges Basins that allow diapausing *C. finmarchicus* to aggregate passively below the convective layer so that the copepods are retained in the basins; late stage *C. finmarchicus* in dense aggregations in the Gulf of Maine and Georges Bank region; and diapausing *C. finmarchicus* in aggregations in the Gulf of Maine and Georges Bank region.

We have considered whether the proposed action would have any effects to right whale critical habitat. Copepods in critical habitat originate from Jordan, Wilkinson, and George's Basin. Vessels transiting from Canada may have routes through this area; however, this limited number of vessels is not expected to have effects that would prevent right whales' ability to forage and utilize the features of critical habitat. The proposed action will also not affect any of the physical or oceanographic conditions that serve to aggregate copepods in designated critical habitat. As required by Federal regulations, all vessels would maintain 1,640 ft (500 m) or greater from any sighted NARW, which helps ensure the proposed action would not interfere with right whales' ability to access select features within their critical habitat.

Offshore wind farms can reduce wind speed and wind stress which can lead to less mixing, lower current speeds, and higher surface water temperature (Afsharian and Taylor 2019), cause wakes that will result in detectable changes in vertical motion and/or structure in the water column (e.g., Broström 2008; Christiansen and Hasager 2005), as well as detectable wakes downstream from a wind farm by increased turbidity (Vanhellemont and Ruddick 2014). Wind farms may also have an opposite effect in which the associated wind wake generates strong horizontal shear wind stress, which creates wind stress curl that produces upwelling and downwelling dipoles in the ocean (Broström 2008; van Berkel et al. 2020). However, there is no information to suggest that effects from the CVOW-C project would extend to Unit 1. The CVOW-C project is roughly 378 nautical miles (700 km) from Unit 1 right whale critical habitat and 217 nautical miles (400 km; straight line distance) from Unit 2 and, thus, it is not anticipated to affect the oceanographic features of that critical habitat. Therefore, we have determined that effects of the proposed action on right whale critical habitat would be insignificant and not likely to adversely affect. For more information on potential effects of the CVOW-C wind

farm on oceanographic conditions, please refer to the Changes in Oceanographic and Hydrological Conditions section of the Stressors Not Likely to Adversely Affect Listed Species or Habitat (Section 7.2.9).

As identified in the NARW critical habitat designation final rule (81 FR 4837), the physical and biological features essential to the conservation of the NARW that provide calving area functions in Unit 2 are: (i) Sea surface conditions associated with Force 4 or less on the Beaufort Scale; (ii) Sea surface temperatures of 7 °C to 17 °C; and, (iii) Water depths of 6 to 28 m, where these features simultaneously co-occur over contiguous areas of at least 231 nmi<sup>2</sup> of ocean waters during the months of November through April. When these features are available, they are selected by right whale cows and calves in dynamic combinations that are suitable for calving, nursing, and rearing, and which vary, within the ranges specified, depending on factors such as weather and age of the calves. While a minimal number of vessels may transit from the Gulf of Mexico to the project area, they are unlikely to transit through the coastal habitat designated at Unit 2 because they would be expected to transit farther offshore. It is extremely unlikely, and therefore we consider potential effects discountable, that the proposed action would affect Unit 2 of right whale critical habitat.

#### **4.11 Atlantic Sturgeon Critical Habitat for All Listed Distinct Population Segments**

Critical habitat has been designated for all 5 DPSs of Atlantic sturgeon (82 FR 39160; effective date September 18, 2017). The project area does not overlap with any Atlantic sturgeon critical habitat but is adjacent to the Chesapeake Bay DPS tributaries. Vessel transits are the only project activity that could overlap with Atlantic sturgeon critical habitat in the action area.

Vessel transit would not include the rivers identified for the Gulf of Maine, New York Bight, Carolina, or South Atlantic DPS critical habitats because vessels in these areas would only transit in offshore waters. Vessels transiting to the ports of Portsmouth, Virginia, and Norfolk, Virginia would not travel through critical habitat of any Chesapeake Bay Atlantic sturgeon DPS; although these ports are close to the James River critical habitat boundary (82 FR 39253), ports used as part of the proposed action would be outside critical habitat. No project vessel would transit within the James River. Therefore, it is extremely unlikely the proposed action would affect any essential physical and biological features in this critical habitat, and the potential for adverse effects from the proposed action is discountable.

#### **4.12 Critical Habitat in the Gulf of Mexico**

Critical habitat currently designated within the U.S. Gulf of Mexico includes: (1) Gulf sturgeon (*Acipenser oxyrinchus desotoi*) critical habitat (68 FR 13370) which comprises 14 geographic areas including freshwater rivers and tributaries and nearshore marine and estuarine habitats between the mouth of the Mississippi to the Suwannee River in Florida; (2) smalltooth sawfish (*Pristis ectinotea*) critical habitat designated in 2 coastal areas of south Florida in the Charlotte Harbor Estuary and the Ten Thousand Islands/Everglades (74 FR 45353); and (3) breeding, overwintering, nearshore reproductive, and *Sargassum* habitat for the northwest Atlantic Ocean DPS of loggerhead sea turtles (*Caretta caretta*) (79 FR 9855).

The only proposed activity that would occur in the Gulf of Mexico would be a single vessel transit. No anchoring or other activities that could disturb the seafloor would occur as part of the action within the designated critical habitats in the Gulf of Mexico. Both Gulf sturgeon and smalltooth sawfish critical habitats are close to the coast in shallow waters, and vessel transit for a large offshore wind support vessel would not be expected to traverse these areas.

Critical habitat in the Gulf of Mexico for the northwest Atlantic Ocean DPS of loggerhead sea turtles includes breeding, overwintering, nearshore reproductive, and *Sargassum* habitat. The single vessel transit within the Gulf of Mexico would not be expected to alter temperatures, depths, ocean currents, convergence zones, nesting

beaches, prey abundance, or availability of any of the critical habitat types. Vessels could be a source of minimal lighting, but not to a level that would be expected to interfere with sea turtle transit through surf and towards open water. Vessel operators would avoid transiting through areas of floating *Sargassum* lines or mats. In the event that operational safety prevents avoidance of such areas, vessels would slow to 4 knots while transiting through such areas. Considering the precautionary measures and there is only one vessel transit proposed, effects to sea loggerhead turtle habitat in the Gulf of Mexico would be insignificant.

Critical habitat has been proposed for green sea turtles (*Chelonia mydas*), which includes habitat in the Atlantic and Gulf of Mexico for the North Atlantic DPS (88 FR 46572). The proposed critical habitat includes 4 types of physical and biological features: reproductive, migratory, benthic foraging/resting, and surface-pelagic foraging/resting (“*Sargassum*”). Proposed critical habitat for the North Atlantic DPS of green sea turtles includes areas on the coasts of North Carolina, Florida, Texas, and Puerto Rico, as well as larger areas in the Atlantic and Gulf of Mexico when *Sargassum* habitat occurs. The proposed green sea turtle critical habitat is very similar in its components and potential stressors to loggerhead sea turtle critical habitat, discussed above. Therefore, the same conclusions as for loggerhead sea turtles would be expected, so effects to green sea turtle habitat in the Gulf of Mexico would be insignificant.

Critical habitat for Rice’s whale (*Balaenoptera ricei*) has been proposed in the Gulf of Mexico on the Gulf of Mexico continental shelf and slope associated waters between the 100 and 400 m isobaths (88 FR 47453). Proposed Rice’s whale critical habitat includes “sufficiently quiet conditions for normal use and occupancy, including intraspecific communication, navigation, and detection of prey, predators, and other threats.” Other aspects of the proposed critical habitat include small demersal and vertically migrating prey species, ocean productivity, and bottom temperatures. The only activity proposed for the Gulf of Mexico is one vessel transit, therefore the effects of the proposed action on Rice’s whale proposed critical habitat would be insignificant.

## 5 STATUS OF THE SPECIES LIKELY TO BE ADVERSELY AFFECTED

This opinion examines the status of the following ESA-listed species (or DPSs) that are likely to be adversely affected by the proposed action: fin whale, NARW, sei whale, sperm whale, green turtle – North Atlantic DPS; leatherback sea turtle; loggerhead sea turtle – Northwest Atlantic DPS; and Kemp’s ridley sea turtle.

The evaluation of adverse effects in this opinion begins by summarizing the biology and ecology of those species that are likely to be adversely affected and what is known about their life histories in the action area. The status of these ESA-listed species is determined by the level of risk they face based on parameters considered in documents such as recovery plans, status reviews, and listing decisions. This helps to inform the description of the species’ current “reproduction, numbers, or distribution,” which is part of the process of determining whether an action is likely to jeopardize the continued existence of listed species (50 C.F.R. §402.02).

More detailed information on the status and trends of these ESA-listed species, and their biology and ecology can be found in the listing regulations and critical habitat designations published in the Federal Register, status reviews, recovery plans, and on NMFS’ website: (<https://www.fisheries.noaa.gov/find-species>).

One factor affecting the range wide status of marine mammals, sea turtles, and aquatic habitat at large is climate change. Climate change will be discussed in the Environmental Baseline section.

### 5.1 Fin Whale (*Balaenoptera physalus*)

Globally there is 1 species of fin whale, *Balaenoptera physalus*. Fin whales occur in all major oceans of the Northern and Southern Hemispheres (NMFS 2010a, Figure 8). Within this range, 3 subspecies of fin whales are



recognized: *B. p. physalus* in the Northern Hemisphere, and *B. p. quoyi* and *B. p. patachonica* (a pygmy form) in the Southern Hemisphere (NMFS 2010c). For management purposes in the northern Hemisphere, the United States divides, *B. p. physalus*, into 4 stocks: Hawaii, California/Oregon/Washington, Alaska (Northeast Pacific), and Western North Atlantic (Hayes et al. 2019; NMFS 2010c).



**Figure 8. Range of the fin whale**

Fin whales are distinguishable from other whales by a sleek, streamlined body, with a V-shaped head, a tall hooked dorsal fin, and a distinctive color pattern of a black or dark brownish-gray body and sides with a white ventral surface. The lower jaw is gray or black on the left side and creamy white on the right side. The fin whale was listed as endangered on December 2, 1970 (35 FR 18319).

Information available from the recovery plan (NMFS 2010c), recent stock assessment reports (Carretta et al. 2019a; Hayes et al. 2022a; Muto et al. 2019), the five-year status review (NMFS 2019b), as well as the recent International Union for the Conservation of Nature's (IUCN) fin whale assessment (Cooke 2018b) were used to summarize the life history, population dynamics and status of the species as follows.

### 5.1.1 Life History

Fin whales can live, on average, 80 to 90 years. They have a gestation period of less than 1 year, and calves nurse for 6 to 7 months. Sexual maturity is reached between 6 and 10 years of age with an average calving interval of 2 to 3 years. They mostly inhabit deep, offshore waters of all major oceans. They winter at low latitudes, where they calve and nurse, and summer at high latitudes, where they feed, although some fin whales appear to be residential to certain areas.

### 5.1.2 Population Dynamics

The pre-exploitation estimate for the fin whale population in the entire North Atlantic was approximately 30,000-50,000 animals (NMFS 2010c), and for the entire North Pacific Ocean, approximately 42,000 to 45,000 animals (Ohsumi and Wada 1974). In the Southern Hemisphere, prior to exploitation, the fin whale population was approximately 40,000 whales (Mizroch et al. 1984a). In the North Atlantic Ocean, fin whales were heavily exploited from 1864 to the 1980s; over this timeframe, approximately 98,000 to 115,000 fin whales were killed (IWC 2017). Between 1910 and 1975, approximately 76,000 fin whales were recorded taken by modern



whaling in the North Pacific; this number is likely higher as many whales killed were not identified to species or while killed, were not successfully landed (Allison 2017). Over 725,000 fin whales were killed in the Southern Hemisphere from 1905 to 1976 (Allison 2017).

In the North Atlantic Ocean, the IWC has defined 7 management stocks of fin whales: (1) North Norway (2) East Greenland and West Iceland (EGI); (3) West Norway and the Faroes; (4) British Isles, Spain and Portugal; (5) West Greenland and (6) Nova Scotia, (7) Newfoundland and Labrador (Donovan 1991; NMFS 2010c). Based on 3 decades of survey data in various portions of the North Atlantic, the IWC estimates that there are approximately 79,000 fin whales in this region. Under the present IWC scheme, fin whales off the eastern United States, Nova Scotia and the southeastern coast of Newfoundland are believed to constitute a single stock; in U.S. waters, NMFS classifies these fin whales as the Western North Atlantic stock (Donovan 1991; Hayes et al. 2019; NMFS 2010c). NMFS' best estimate of abundance for the Western North Atlantic Stock of fin whales is 6,802 individuals ( $N_{\min}=5,573$ ); this estimate is the sum of the 2016 NOAA shipboard and aerial surveys and the 2016 Canadian Northwest Atlantic International Sightings Survey (Hayes et al. 2022a). Currently, there is no population estimate for the entire fin whale population in the North Pacific (Cooke 2018b). However, abundance estimates for 3 stocks in U.S. Pacific Ocean waters do exist: Northeast Pacific ( $N=3,168$ ;  $N_{\min}=2,554$ ), Hawaii ( $N=154$ ;  $N_{\min}=75$ ), and California/Oregon/Washington ( $N=9,029$ ;  $N_{\min}=8,127$ ; Nadeem et al. 2016). Abundance data for the Southern Hemisphere stock remain highly uncertain; however, available information suggests a substantial increase in the population has occurred (Thomas et al. 2016).

In the North Atlantic, estimates of annual growth rate for the entire fin whale population in this region is not available (Cooke 2018b). However, in U.S. Atlantic waters NMFS has determined that until additional data are available, the cetacean maximum theoretical net productivity rate of 4.0% will be used for the Western North Atlantic stock (Hayes et al. 2019). In the North Pacific, estimates of annual growth rate for the entire fin whale population in this region is not available (Cooke 2018b). However, in U.S. Pacific waters, NMFS has determined that until additional data are available, the cetacean maximum theoretical net productivity rate of 4.0% will be used for the Northeast Pacific stock (Muto et al. 2019; NMFS 2016b). Overall population growth rates and total abundance estimates for the Hawaii stock of fin whales are not available at this time (Carretta et al. 2018). Based on line transect studies between 1991-2014, there was estimated a 7.5% increase in mean annual abundance in fin whales occurring in waters off California, Oregon, and Washington; to date, this represents the best available information on the current population trend for the overall California/Oregon/Washington stock of fin whales (Carretta et al. 2019a; Nadeem et al. 2016).<sup>11</sup> Since 2005, the fin whale abundance increase has been driven by increases off northern California, Oregon, and Washington; numbers off Central and Southern California have remained stable (Nadeem et al. 2016). For Southern Hemisphere fin whales, as noted above, overall information suggests a substantial increase in the population; however, the rate of increase remains poorly quantified (Cooke 2018b).

Archer et al. (2013) examined the genetic structure and diversity of fin whales globally. Full sequencing of the mitochondrial DNA genome for 154 fin whales sampled in the North Atlantic Ocean, North Pacific Ocean, and Southern Hemisphere, resulted in 136 haplotypes, none of which were shared among ocean basins suggesting differentiation at least at this geographic scale. However, North Atlantic fin whales appear to be more closely related to the Southern Hemisphere population, as compared to fin whales in the North Pacific Ocean, which may indicate a revision of the subspecies delineations is warranted. Generally, haplotype diversity was found to

---

<sup>11</sup> Since 2005, the fin whale abundance increase has been driven by increases off northern California, Oregon, and Washington; numbers off Central and Southern California have remained stable Carretta, J. 2021. Fin Whale (*Balaenoptera physalus velifera*): California/Oregon/Washington Stock. Pages 196-203 in Pacific Marine Mammal Stock Assessments 2020 Final, Nadeem, K., J. E. Moore, Y. Zhang, and H. Chipman. 2016. Integrating population dynamics models and distance sampling data: A spatial hierarchical state-space approach. *Ecology* 97(7):1735-1745..

be high both within and across ocean basins (Archer et al. 2013). Such high genetic diversity and lack of differentiation within ocean basins may indicate that despite some populations having small abundance estimates, the species may persist long-term and be somewhat protected from substantial environmental variance and catastrophes. Archer et al. (2019) suggests that within the Northern Hemisphere, populations in the North Pacific and North Atlantic oceans can be considered at least different subspecies, if not different species.

### **5.1.3 Status**

The fin whale is endangered because of past commercial whaling. Prior to commercial whaling, hundreds of thousands of fin whales existed. Fin whales may be killed under “aboriginal subsistence whaling” in Greenland, under Japan’s scientific whaling program, and Iceland’s formal objection to the IWC’s ban on commercial whaling. Additional threats include vessel strikes, reduced prey availability due to overfishing or climate change, and sound. The species’ overall large population size may provide some resilience to current threats, but trends are largely unknown. The total annual estimated average human-caused mortality and serious injury for the western North Atlantic fin whale for the period 2015–2019 is 1.85: 1.45 incidental fishery interactions and 0.40 vessel collisions (Henry et al. 2022). Hayes et al. (2022a) notes that these represent a minimum estimate of human-caused mortality, which is almost certainly biased low.

### **5.1.4 Critical Habitat**

No critical habitat has been designated for the fin whale.

### **5.1.5 Recovery Goals**

The goal of the 2010 Recovery Plan for the fin whale (NMFS 2010c) is to promote the recovery of fin whales to the point at which they can be downlisted from endangered to threatened status, and ultimately to remove them from the list of Endangered and Threatened Wildlife and Plants, under the provisions of the ESA. The intermediate goal is to reclassify the species from endangered to threatened. The recovery plan also includes downlisting and delisting criteria. Key elements for the recovery program for fin whales are:

1. Coordinate state, Federal, and international actions to implement recovery actions and maintain international regulation of whaling for fin whales;
2. Determine population discreteness and population structure of fin whales;
3. Develop and apply methods to estimate population size and monitor trends in abundance;
4. Conduct risk analysis;
5. Identify, characterize, protect, and monitor habitat important to fin whale populations in U.S. waters and elsewhere;
6. Investigate causes and reduce the frequency and severity of human-caused injury and mortality;
7. Determine and minimize any detrimental effects of anthropogenic noise in the oceans;
8. Maximize efforts to acquire scientific information from dead, stranded, and/or entrapped fin whales; and,
9. Develop post-delisting monitoring plan.

In February 2019, NMFS published a Five-Year Review for fin whales. This 5-year review indicates that, based on a review of the best available scientific and commercial information, that the fin whale should be downlisted

from endangered to threatened. The review also recommended that NMFS consider whether listing at the subspecies or distinct population segment level is appropriate in terms of potential conservation benefits and the use of limited agency resources (NMFS 2019b). To date, no changes to the listing for fin whales have been proposed.

## 5.2 North Atlantic Right Whale (*Eubalaena glacialis*)

There are 3 species classified as right whales (genus *Eubalaena*): North Pacific (*E. japonica*), Southern (*E. australis*), and North Atlantic (*E. glacialis*). The NARW is the only species of right whale that occurs in the North Atlantic Ocean (Figure 9) and, therefore, is the only species of right whale that may occur in the action area.

NARWs occur primarily in the western North Atlantic Ocean. However, there have been acoustic detections, reports, and/or sightings of NARWs in waters off Greenland (east/southeast), Newfoundland, northern Norway, and Iceland, as well as within Labrador Basin (Hamilton et al. 1998; Jacobsen et al. 2004; Knowlton et al. 1992b; Mellinger et al. 2011). These latter sightings/detections are consistent with historic records documenting NARWs south of Greenland, in the Denmark straits, and in eastern North Atlantic waters (Kraus et al. 2007). There is also evidence of possible historic NARW calving grounds in the Mediterranean Sea (Rodrigues et al. 2018), an area not currently considered as part of this species' historical range.

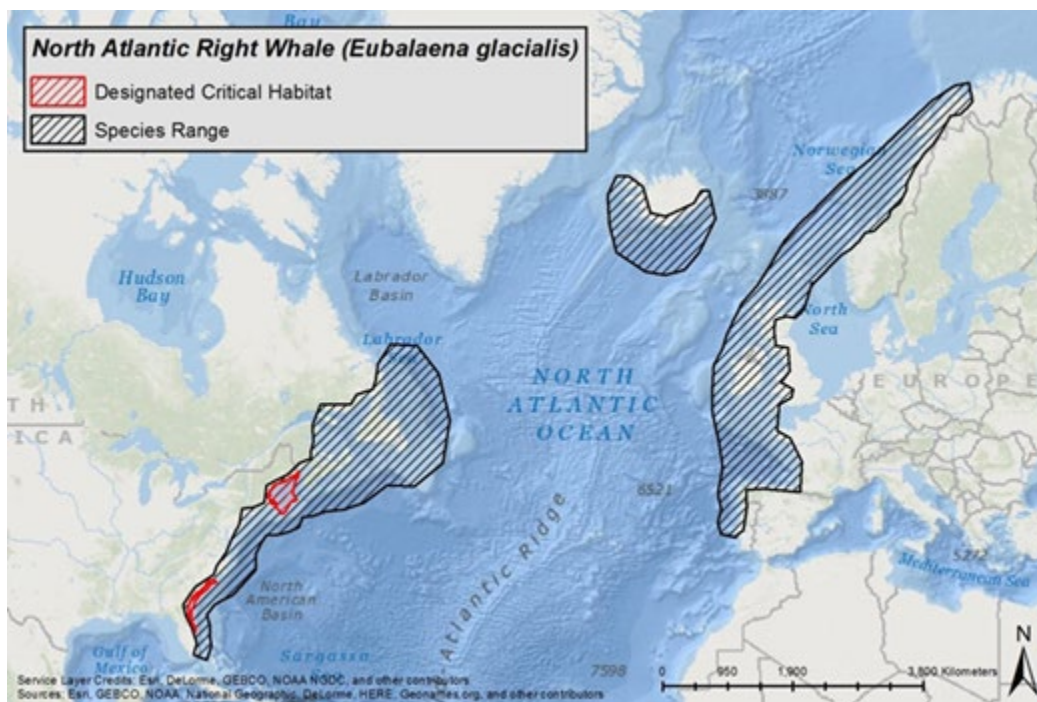

Figure 9. Approximate historic range and currently designated U.S. critical habitat of the NARW

The NARW is distinguished by its stocky body and lack of a dorsal fin. The species was listed as endangered on December 2, 1970. We used information available in the most recent five-year review for NARWs (NMFS 2022d), the most recent stock assessment report (Hayes et al. 2022a; Hayes et al. 2023), and the scientific literature to summarize the status of the species, as follows.

### 5.2.1 Life History

The maximum lifespan of NARWs is unknown, but 1 individual reached at least 70 years of age (Hamilton et al. 1998; Kenney 2009). Previous modeling efforts suggest that in 1980, females had a life expectancy of approximately 51.8 years of age, which was twice that of males at the time (Fujiwara and Caswell 2001); however, by 1995, female life expectancy was estimated to have declined to approximately 14.5 years (Fujiwara and Caswell 2001). Most recent estimates indicate that NARW females are only living to 45 and males to age 65 (<https://www.fisheries.noaa.gov/species/north-atlantic-right-whale>). Females, ages 5+, have reduced survival relative to males, ages 5+, resulting in a decrease in female abundance relative to male abundance (Pace et al. 2017). Specifically, state-space mark-recapture model estimates show that from 2010-2015, males declined just under 4.0%, and females declined approximately 7% (Pace et al. 2017).

Gestation is estimated to be between 12 and 14 months, after which calves typically nurse for around 1 year (Cole et al. 2013; Kenney 2009; Kraus and Hatch 2001; Lockyer 1984). After weaning a calf, females typically undergo a ‘resting’ period before becoming pregnant again, presumably because they need time to recover from the energy deficit experienced during lactation (Fortune et al. 2013; Fortune et al. 2012; Pettis et al. 2017a). From 1983 to 2005, annual average calving intervals ranged from 3 to 5.8 years with an overall average of 4.23 years (Kraus et al. 2007). Between 2006 and 2015, annual average calving intervals continued to vary within this range, but in 2016 and 2017 longer calving intervals were reported: 6.3 to 6.6 years in 2016 and 10.2 years in 2017 (Hayes et al. 2018; Pettis and Hamilton 2015; Pettis and Hamilton 2016; Pettis et al. 2018; Pettis et al. 2020). There were no calves recorded in 2018. Annual average calving interval between 2019 and 2022 ranged from a low of 7 in 2019 to a high of 9.2 in 2021 (Pettis et al. 2022). The calving index is the annual percentage of reproductive females assumed alive and available to calve that was observed to produce a calf. This index averaged 47% from 2003 to 2010 but has dropped to an average of 17% since 2010 (Moore et al. 2021). The percentage of available females that had calves ranged from 11.9% to 30.5% from 2019-2022 (Pettis et al. 2022). Females have been known to give birth as young as 5 years old, but the mean age of a female first giving birth is 10.2 years old (n=76, range 5 to 23; (Moore et al. 2021). Taken together, changes to inter-birth interval and age to first reproduction suggest that both parous (having given birth) and nulliparous (not having given birth) females are experiencing delays in calving. These calving delays correspond with the recent distribution shifts. The low reproductive rate of right whales is likely the result of several factors including nutrition (Fortune et al. 2013; Moore et al. 2021). Evidence also indicates that NARWs are growing to shorter adult lengths than in earlier decades (Stewart et al. 2021) and are in poor body condition compared to southern right whales (Christiansen et al. 2020). As stated in the draft 2023 SAR, all these changes may result from a combination of documented regime shifts in primary feeding habitats (Meyer-Gutbrod et al. 2021; Meyer-Gutbrod and Greene 2014; Record et al. 2019), and increased energy expenditures related to non-lethal entanglements (Pettis et al. 2017b; Rolland et al. 2016; van der Hoop et al. 2017b). As noted in the 2022 Five-Year Review (NMFS 2022d), poor body condition, arrested growth, and maternal body length have led to reduced reproductive success and are contributors to low birth rates for the population over the past decade (Christiansen et al. 2020; Reed et al. 2022; Stewart et al. 2022; Stewart et al. 2021).

Pregnant NARWs migrate south, through the mid-Atlantic region of the U.S., to low latitudes during late fall where they overwinter and give birth in shallow, coastal waters (Kenney 2009; Krzystan et al. 2018). During spring, these females and new calves migrate to high latitude foraging grounds where they feed on large concentrations of copepods, primarily *C. finmarchicus* (Mayo et al. 2018; NMFS 2017b). Some non-reproductive NARWs (males, juveniles, non-reproducing females) also migrate south, although at more variable times throughout the winter. Others appear to not migrate south and remain in the northern feeding grounds year round or go elsewhere (Bort et al. 2015; Mayo et al. 2018; Morano et al. 2012; NMFS 2017b; Stone et al. 2017). Nonetheless, calving females arrive to the southern calving grounds earlier and stay in the area more than twice

as long as other demographics (Krzystan et al. 2018). Little is known about NARW habitat use in the mid-Atlantic, but recent acoustic data indicate near year round presence of at least some whales off the coasts of New Jersey, Virginia, and North Carolina (Davis et al. 2017a; Hodge et al. 2015; Salisbury et al. 2016; Whitt et al. 2013). While it is generally not known where NARWs mate, some evidence suggests that mating may occur in the northern feeding grounds (Cole et al. 2013; Matthews et al. 2014).

## 5.2.2 Population Dynamics

Today, NARWs are primarily found in the western North Atlantic, from their calving grounds in lower latitudes off the coast of the southeastern United States to their feeding grounds in higher latitudes off the coast of New England and Nova Scotia (Hayes et al. 2018). Beginning in 2010, a change in seasonal residency patterns has been documented through visual and acoustic monitoring with declines in presence in the Bay of Fundy, Gulf of Maine, and Great South Channel, and more animals being observed in Cape Cod Bay, the Gulf of Saint Lawrence, the mid-Atlantic, and south of Nantucket, Massachusetts (Daoust et al. 2018; Davies et al. 2019; Davis et al. 2017b; Hayes et al. 2018; Hayes et al. 2019; Meyer-Gutbrod et al. 2018; Moore et al. 2021; Pace et al. 2017; Quintana-Rizzo et al. 2021). Right whales have been observed nearly year round in the area south of Martha's Vineyard and Nantucket, with highest sightings rates between December and May (Leiter et al. 2017; O'Brien et al. 2022; Quintana-Rizzo et al. 2021; Stone et al. 2017). Increased detections of right whales in the Gulf of St. Lawrence have been documented from late spring through the fall (Cole et al. 2016; DFO 2021; Simard et al. 2019).

There are 2 recognized populations of NARWs, an eastern, and a western population. Very few individuals likely make up the population in the eastern Atlantic, which is thought to be functionally extinct (Best et al. 2001). However, in recent years, a few known individuals from the western population have been seen in the eastern Atlantic, suggesting some individuals may have wider ranges than previously thought (Kenney 2009). Specifically, there have been acoustic detections, reports, and/or sightings of NARWs in waters off Greenland (east/southeast), Newfoundland, northern Norway, and Iceland, as well as within Labrador Basin (Jacobsen et al. 2004; Knowlton et al. 1992a; Mellinger et al. 2011). It is estimated that the North Atlantic historically (i.e., pre-whaling) supported between 9,000 and 21,000 right whales (Monsarrat et al. 2016). The western population may have numbered fewer than 100 individuals by 1935, when international protection for right whales came into effect (Kenney et al. 1995).

Genetic analyses, based upon mitochondrial and nuclear DNA analyses, have consistently revealed an extremely low level of genetic diversity in the NARW population (Hayes et al. 2018; Mcleod and White 2010; Schaeff et al. 1997). Waldick et al. (2002) concluded that the principal loss of genetic diversity occurred prior to the 18th century, with more recent studies hypothesizing that the loss of genetic diversity may have occurred prior to the onset of Basque whaling during the 16th and 17th century (Mcleod 2008; Rastogi et al. 2004; Reeves et al. 2007; Waldick et al. 2002). The persistence of low genetic diversity in the NARW population might indicate inbreeding; however, based on available data, no definitive conclusions can be reached at this time (Hayes et al. 2019; Radvan 2019; Schaeff et al. 1997). By combining 25 years of field data (1980-2005) with high-resolution genetic data, Frasier et al. (2013) found that NARW calves born between 1980 and 2005 had higher levels of microsatellite (nuclear) heterozygosity than would be expected from this species' gene pool. The authors concluded that this level of heterozygosity is due to postcopulatory selection of genetically dissimilar gametes and that this mechanism is a natural means to mitigate the loss of genetic diversity, over time, in small populations (Frasier et al. 2013).

In the western North Atlantic, NARW abundance was estimated to be 270 animals in 1990 (Pace et al. 2017). From 1990 to 2011, right whale abundance increased by approximately 2.8% per year, despite a decline in 1993 and no growth between 1997 and 2000 (Pace et al. 2017). However, since 2011, when the abundance peaked at

481 animals, the population has been in decline, with a 99.99% probability of a decline of just under 1% per year (Pace et al. 2017). Between 1990 and 2015, survival rates appeared relatively stable, but differed between the sexes, with males having higher survivorship than females (males:  $0.985 \pm 0.0038$ ; females:  $0.968 \pm 0.0073$ ) leading to a male-biased sex ratio (approximately 1.46 males per female; Pace et al. 2017).

As reported in the most recent final SAR (Hayes et al. 2023), the western NARW stock size is estimated based on a published state-space model of the sighting histories of individual whales identified using photo-identification techniques (Pace et al. 2017; Pace et al. 2021). Sightings histories were constructed from the photo-ID recapture database as it existed in December 2021 and included photographic information up through November 2020. Using the hierarchical, state-space Bayesian open population model of these histories produced a median abundance value (Nest) as of November 30, 2020 of 338 individuals (95% CI: 325–350) and a minimum population estimate of 332 (Hayes et al. 2023).

Each year, scientists at NMFS' Northeast Fisheries Science Center estimate the right whale population abundance and share that estimate at the North Atlantic Right Whale Consortium's annual meeting in a "Report Card." This estimate is considered preliminary and undergoes further review before being included in the draft North Atlantic Right Whale Stock Assessment Report. Each draft stock assessment report is peer-reviewed by 1 of 3 regional Scientific Review Groups, revised after a public comment period, and published. The 2022 "Report Card" (Pettis et al. 2022) data reports a preliminary population estimate for 2021 using data as of August 30, 2022 is 340 (+/- 7). Pettis et al. (2022) also report that 15 mother calf pairs were sighted in 2022, down from 18 in 2021. There were no first time mothers sighted in 2022. Initial analyses detected at least 16 new entanglements in 2022: 5 whales seen with gear and 11 with new scarring from entanglements. Additionally, there was 1 non-fatal vessel strike detected. No carcasses were detected. Of the 15 calves born in 2022, 1 is known to have died and another is thought likely to have died. During the 2022-2023 season, there were 11 mothers with associated calves and one newborn documented alone that was later found dead.

In addition to finding an overall decline in the NARW population, Pace et al. (2017) also found that between 1990 and 2015, the survival of age 5+ females relative to 5+ males has been reduced; this has resulted in diverging trajectories for male and female abundance. Specifically, there was an estimated 142 males (95% CI=143-152) and 123 females (95% CI=116-128) in 1990; however, by 2015, model estimates show the species was comprised of 272 males (95% CI=261-282) and 186 females (95% CI=174-195; Pace et al. 2017). Calving rates also varied substantially between 1990 and 2015 (i.e., 0.3% to 9.5%), with low calving rates coinciding with 3 periods (1993-1995, 1998-2000, and 2012-2015) of decline or no growth (Pace et al. 2017). Using generalized linear models, Corkeron et al. (2018) found that between 1992 and 2016, NARW calf counts increased at a rate of 1.98% per year. Using the highest annual estimates of survival recorded over the time series from Pace et al. (2017), and an assumed calving interval of approximately 4 years, Corkeron et al. (2018) suggests that the NARW population could potentially increase at a rate of at least 4% per year if there was no anthropogenic mortality.<sup>12</sup> This rate is approximately twice that observed, and the analysis indicates that adult female mortality is the main factor influencing this rate (Corkeron et al. 2018). Right whale births remain significantly below what is expected and the average inter-birth interval remains high (Pettis et al. 2022). Additionally, there were no first-time mothers in 2022, underscoring recent research findings that fewer adult, nulliparous females are becoming reproductively active (Reed et al. 2022).

---

<sup>12</sup> Based on information in the North Atlantic Right Whale Catalog, the mean calving interval is 4.69 years Corkeron, P., and coauthors. 2018. The recovery of North Atlantic right whales, *Eubalaena glacialis*, has been constrained by human-caused mortality. *Royal Society Open Science* 5(11):180892.. Ibid. assumed a 4 year calving interval as the approximate mid-point between the North Atlantic Right Whale Catalog calving interval and observed calving intervals for southern right whales (i.e., 3.16 years for South Africa, 3.42 years for Argentina, 3.31 years for Auckland Islands, and 3.3 years for Australia).

### 5.2.3 Status

The NARW is listed under the ESA as endangered. Anthropogenic mortality and sublethal stressors (i.e., entanglement) that affect reproductive success are currently affecting the ability of the species to recover (Corkeron et al. 2018; Stewart et al. 2021). Currently, none of the species recovery goals (see below) have been met. With whaling now prohibited, the 2 major known human causes of mortality are vessel strikes and entanglement in fishing gear (Hayes et al. 2018). Estimates of total annual anthropogenic mortality (i.e., ship strike and entanglement in fishing gear), as well as the number of undetected anthropogenic mortalities, for NARWs are presented in the annual stock assessment reports. These anthropogenic threats appear to be worsening (Hayes et al. 2018).

On June 7, 2017, NMFS declared an Unusual Mortality Event (UME) for the NARW, as a result of 17 observed right whale mortalities in the U.S. and Canada. Under the Marine Mammal Protection Act, a UME is defined as "a stranding that is unexpected; involves a significant die-off of any marine mammal population; and demands immediate response." As of July 2023, there are 36 confirmed mortalities for the UME, 33 serious injuries, and 29 sublethal injuries or illness (for more information on UMEs, see <https://www.fisheries.noaa.gov/national/marine-mammal-protection/marine-mammal-unusual-mortality-events>). Mortalities are recorded as vessel strike (12), entanglement (9), perinatal (2), unknown/undetermined (3), or not examined (10)<sup>13</sup>.

The NARW population continues to decline. As noted above, between 1990 to 2011, right whale abundance increased by approximately 2.8% per year; however, since 2011 the population has been in decline (Pace et al. 2017). The draft 2023 SAR reports an overall abundance decline between 2011 and 2020 of 29.7% (Hayes et al. 2023). Recent modeling efforts indicate that low female survival, a male biased sex ratio, and low calving success are contributing to the population's current decline (Pace et al. 2017). For instance, 5 new calves were documented in 2017 calving season, zero in 2018, and 7 in 2019 (Pettis et al. 2018; Pettis et al. 2020), these numbers of births are well below the number needed to compensate for expected mortalities. More recently, there were 10 calves in the 2020 calving season, 18 calves in 2021, and 15 in 2022. Two of the 2020 calves and 1 of the 2021 calves died or were seriously injured due to vessel strikes. Two additional calves were reported in the 2021 season, but were not seen as a mother/calf pair. One animal stranded dead with no evidence of human interaction and initial results suggest the calf died during birth or shortly thereafter. The second animal was an anecdotal report of a calf off the Canary Islands. Two calves in 2022 are suspected to have died, with the causes of death unknown. As of July 13, 2023, 12 mother-calf pairs have been sighted in the 2022-2023 calving season (<https://www.fisheries.noaa.gov/national/endangered-species-conservation/north-atlantic-right-whale-calving-season-2023>).

Long-term photographic identification data indicate new calves rarely go undetected (Kraus et al. 2007; Pace et al. 2017). While there are likely a multitude of factors involved, low calving has been linked to poor female health (Rolland et al. 2016) and reduced prey availability (Devine et al. 2017; Johnson et al. 2017; Meyer-Gutbrod et al. 2018; Meyer-Gutbrod and Greene 2014). A recent study comparing NARWs to other right whale species found that juvenile, adult, and lactating female NARWs all had lower body condition scores compared to the southern right whale populations, with lactating females showing the largest difference; however, NARW calves were in good condition (Christiansen et al. 2020). While some of the difference could be the result of genetic isolation and adaptations to local environmental conditions, the authors suggest that the magnitude indicates that NARW females are in poor condition, which could be suppressing their growth, survival, age of

---

<sup>13</sup> <https://www.fisheries.noaa.gov/national/marine-life-distress/2017-2023-north-atlantic-right-whale-unusual-mortality-event>; last accessed July 12, 2023

sexual maturation and calving rates. In addition, they conclude that the observed differences are most likely a result of differences in the exposure to anthropogenic factors (Christiansen et al. 2020). Furthermore, entanglement in fishing gear appears to have substantial health and energetic costs that affect both survival and reproduction (Hayes et al. 2018; Lysiak et al. 2018; Pettis et al. 2017b; Robbins et al. 2015; Rolland et al. 2017; van der Hoop et al. 2017a).

Kenney (2018) projected that if all other known or suspected impacts (e.g., vessel strikes, calving declines, climate change, resource limitation, sublethal entanglement effects, disease, predation, and ocean noise) on the population remained the same between 1990 and 2016, and none of the observed fishery related mortality and serious injury occurred, the projected population in 2016 would be 12.2% higher (506 individuals). Furthermore, if the actual mortality resulting from fishing gear is double the observed rate (as estimated in (Pace et al. 2017), eliminating all mortalities (observed and unobserved) could have resulted in a 2016 population increase of 24.6% (562 individuals) and possibly over 600 in 2018 (Kenney 2018).

Given the above information, NARWs' resilience to future perturbations affecting health, reproduction, and survival is expected to be very low (Hayes et al. 2018). The observed (and clearly biased low) human-caused mortality and serious injury was 7.7 right whales per year from 2015 through 2019 (Hayes et al. 2022a). Using the refined methods of Pace et al. (2021), the estimated annual rate of total mortality for the period 2014–2018 was 27.4, which is 3.4 times larger than the 8.15 total derived from reported mortality and serious injury for the same period (Hayes et al. 2022a). The 2023 SAR reports the observed human-caused mortality and serious injury was 8.1 right whales per year from 2016 through 2020 (Hayes et al. 2023). Using the refined methods of Pace et al. (2021), the estimated annual rate of total mortality for the period 2015–2019 was 31.2, which is 4.1 times larger than the 7.7 total derived from reported mortality and serious injury for the same period. Using a matrix population projection model, it is estimated that by 2029 the population will decline from 160 females to the 1990 estimate of 123 females if the current rate of decline is not altered (Hayes et al. 2018).

Climate change poses a significant threat to the recovery of NARWs. The information presented here is summarized from a more complete description of this threat in the 2022 5-Year Review (NMFS 2022d). The documented shift in NARW summer habitat from the Gulf of Maine to waters further north in the Gulf of St. Lawrence in the early 2010s is considered to be related to an oceanographic regime shift in Gulf of Maine waters linked to a northward shift of the Gulf Stream which caused the availability of the primary NARW prey, the copepod *Calanus finmarchicus*, to decline locally, forcing NARWs to forage in areas further north (Meyer-Gutbrod et al. 2021; Record et al. 2019; Sorochan et al. 2019). The shift of NARW distribution into waters further north also created policy challenges for the Canadian government, which had to implement new regulations in areas that were not protected because they were not documented as right whale habitat in the past (Davies and Brilliant 2019; Meyer-Gutbrod et al. 2018; Record et al. 2019).

When prey availability is low, NARW calving rates decline, a well-documented phenomenon through periods of low prey availability in the 1990s and the 2010s; without increased prey availability in the future, low population growth is predicted (Meyer-Gutbrod et al. 2018). Prey densities in the Gulf of St. Lawrence have fluctuated irregularly in the past decade, limiting suitable foraging habitat for NARWs in some years and further limiting reproductive rates (Bishop et al. 2022; Gavrillchuk et al. 2020; Gavrillchuk et al. 2021; Lehoux et al. 2020).

Recent studies have investigated the spatial and temporal role of oceanography on copepod availability and distribution and resulting effects on foraging NARWs. Changes in seasonal current patterns have an effect on the density of *Calanus* species in the Gulf of St. Lawrence, which may lead to further temporal variations over time (Sorochan et al. 2021a). Brennan et al. (2019) developed a model to estimate seasonal fluctuations in *C. finmarchicus* availability in the Gulf of St. Lawrence, which is highest in summer and fall, aligning with



NARW distribution during those seasons. Pendleton et al. (2022) found that the date of maximum occupancy of NARWs in Cape Cod Bay shifted 18.1 days later between 1998 and 2018 and was inversely related to the spring thermal transition date, when the regional ocean temperature surpasses the mean annual temperature for that location, which has trended towards moving earlier each year as an effect of climate change. This inverse relationship may be due to a “waiting room” effect, where NARWs wait and forage on adequate prey in the waters of Cape Cod Bay while richer prey develops in the Gulf of St. Lawrence, and then migrate directly there rather than following migratory pathways used previously (Ganley et al. 2022; Pendleton et al. 2022). Although the date of maximum occupancy in Cape Cod Bay has shifted to later in the spring, initial sightings of individual NARWs have started earlier, indicating that they may be using regional water temperature as a cue for migratory movements between habitats (Ganley et al. 2022).

NARWs rely on late stage or diapause copepods, which are more energy-rich, for prey; diving behavior is highly reliant on where in the vertical strata *C. finmarchicus* is distributed (Baumgartner et al. 2017). There is evidence that *C. finmarchicus* are reaching the diapause phase at deeper depths to account for warming water on the Newfoundland Slope and Scotian Shelf, forcing NARWs to forage deeper and further from shore (Krumhansl et al. 2018; Sorochan et al. 2021a).

Several studies have already used the link between *Calanus* distribution and NARW distribution to determine suitable habitat, both currently and in the future (Gavrilchuk et al. 2020; Pershing et al. 2021; Silber et al. 2017; Sorochan et al. 2021b). Plourde et al. (2019) used suitable habitat modeling using *Calanus* density to confirm new NARW hot spots for summer feeding in Roseway Basin and Grand Manan and identified other potential aggregation areas further out on the Scotian Shelf. Gavrilchuk et al. (2021) determined suitable habitat for reproductive females in the Gulf of St. Lawrence, finding declines in foraging habitat over a 12- year period and indicating that the prey biomass in the area may become insufficient to sustain successful reproduction over time. Ross et al. (2021) used suitable habitat modeling to predict that the Gulf of Maine habitat would continue to decline in suitability until 2050 under a range of climate change scenarios. Similarly, models of future copepod density in the Gulf of Maine have predicted declines of up to 50% under high greenhouse gas emission scenarios by 2080 – 2100 (Grieve et al. 2017). It is clear that climate change does and will continue to have an impact on the availability, supply, aggregation, and distribution of *C. finmarchicus*, and NARW abundance and distribution will continue to vary based on those impacts. However, more research must be done to better understand these factors and associated impacts (Sorochan et al. 2021b). Climate change will likely have other secondary effects on NARWs, such as an increase in harmful algal blooms of the toxic dinoflagellate *Alexandrium catenella* due to warming waters, increasing the risk of NARW exposure to neurotoxins (Boivin-Rioux et al. 2021; Pershing et al. 2021).

#### **5.2.4 Factors Outside the Action Area Affecting the Status of the Right Whale: Fishery Interactions and Vessel Strikes in Canadian Waters**

In Canada, right whales are protected under the Species at Risk Act (SARA) and the Fisheries Act. The right whale was considered a single species and designated as endangered in 1980. SARA includes provisions against the killing, harming, harassing, capturing, taking, possessing, collecting, buying, selling, or trading of individuals or its parts (SARA section 32) and damage or destruction of its residence (SARA section 33). In 2003, the species was split to allow separate designation of the NARW, which was listed as endangered under SARA in May 2003. All marine mammals are subject to the provisions of the marine mammal regulations under the Fisheries Act. These include requirements related to approach, disturbance, and reporting. In the St. Lawrence estuary and the Saguenay River, the maximum approach distance for threatened or endangered whales is 1,312 ft (400 m).

NARWs have died or been seriously injured in Canadian waters by vessel strikes and entanglement in fishing gear (DFO 2014). Serious injury and mortality events are rarely observed where the initial entanglement occurs. After an event, live whales or carcasses may travel hundreds of miles before ever being observed, including into U.S. waters given prevailing currents. It is unknown exactly how many serious injuries and mortalities have occurred in Canadian waters historically. However, at least 14 right whale carcasses and 20 injured right whales were sighted in Canadian waters between 1988 and 2014 (Davies and Brilliant 2019); 25 right whale carcasses were first sighted in Canadian waters or attributed to Canadian fishing gear from 2015 through 2019. In the sections to follow, information is provided on the fishing and shipping industry in Canadian waters, as well as measures the Canadian government is taking (or will be taking) to reduce the level of serious injuries and mortalities to North Atlantic rights resulting from incidental entanglement in fishing gear or vessel strikes.

#### **5.2.4.1 Fishery Interactions in Canadian Waters**

There are numerous fisheries operating in Canadian waters. Rock and toad crab fisheries, as well as fixed gear fisheries for cod, Atlantic halibut, Greenland halibut, winter flounder, and herring have historically had few interactions. While these fisheries deploy gear that pose some risk, this analysis focuses on fisheries that have demonstrated interactions with ESA-listed species (i.e., lobster, snow crab, mackerel, and whelk). Based on information provided by the Department of Fisheries and Oceans Canada (DFO), a brief summary of these fisheries is provided below.

The American lobster fishery is DFO's largest fishery, by landings. It is managed under regional management plans with 41 Lobster Fisheries Areas (Figure 10); in which 10,000 licensed harvesters across Atlantic Canada and Quebec participate. In addition to the one permanent closure in Lobster Fishery Area 40 (Figure 10), fisheries are generally closed during the summer to protect molts. Lobster fishing is most active in the Gulf of Maine, Bay of Fundy, Southern Gulf of St. Lawrence, and coastal Nova Scotia. Most fisheries take place in shallow waters less than 130 ft (40 m) deep and within 8 nmi (15 km) of shore, although some fisheries will fish much farther out and in waters up to 660 ft. (200 m) deep. Management measures are tailored to each Area and include limits on the number of licenses issued, limits on the number of traps, limited and staggered fishing seasons, limits on minimum and maximum carapace size (which differs depending on the Area), protection of egg-bearing females (females must be notched and released alive), and ongoing monitoring and enforcement of fishing regulations and license conditions. The Canadian lobster fisheries use trap/pot gear consistent with the gear used in the American lobster fishery in the U.S. While both Canada and the U.S. lobster fisheries employ similar gears, the two nations employ different management strategies that result in divergent prosecution of the fisheries.

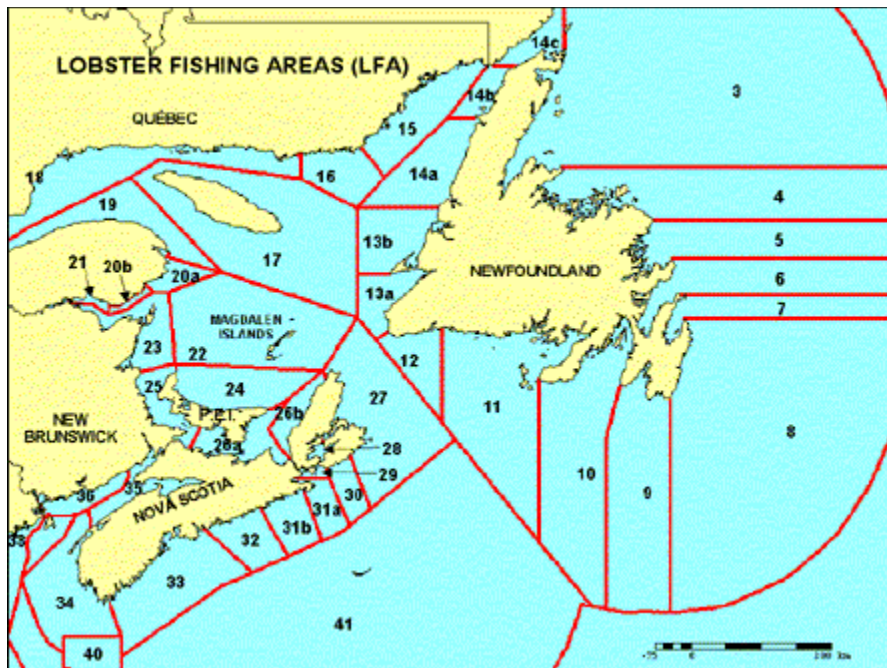

Figure 10. Lobster fishing areas in Atlantic Canada (<https://www.dfo-mpo.gc.ca/fisheries-peches/commercial-commercial/atl-arc/lobster-homard-eng.html>)

The snow crab fishery is DFO's second largest fishery, by landings. It is managed under regional management plans with approximately 60 Snow Crab Management Areas in Canada spanning four regions (Scotia-Fundy, Southern Gulf of St. Lawrence, Northern Gulf of St. Lawrence, and Newfoundland and Labrador).

Approximately 4,000 crab fishery licenses are issued annually.<sup>14</sup> The management of the snow crab fishery is based on annual total allowable catch, individual quotas, trap and mesh restrictions, minimum legal size, mandatory release of female crabs, minimum mesh size of traps, limited seasons, and areas. Protocols are in place to close grids when a percentage of soft-shell crabs in catches is reached. Harvesters use baited conical traps and pots set on muddy or sand-mud bottoms usually at depths of 230-460 ft. (70-140 m). Annual permit conditions have been used since 2017 to minimize the impacts to North Atlantic right whales, as described below.

DFO manages the Atlantic mackerel fishery under one Atlantic management plan, established in 2007. Management measures include fishing seasons, total allowable catch, gear, Safety at Sea fishing areas, licensing, minimum size, fishing gear restrictions, and monitoring. The plan allows the use of the following gear: gillnet, handline, trap net, seine, and weir. When established, the DFO issued 17,182 licenses across four regions, with over 50% of these licenses using gillnet gear. In 2020, DFO issued 7,812 licenses; no gear information was available. Commercial harvest is timed with the migration of mackerel into and out of Canadian waters. In Nova Scotia, the gillnet and trap fisheries for mackerel take place primarily in June and July. Mackerel generally arrive in southwestern Nova Scotia in May and Cape Breton in June. Migration out of the Gulf of St. Lawrence begins in September, and the fishery can continue into October or early November. They may enter the Gulf of St. Lawrence, depending on temperature conditions. The gillnet fishery in the Gulf

<sup>14</sup> <https://www.dfo-mpo.gc.ca/stats/commercial/licences-permis/licences-permis-atl-eng.htm#Species>; Last accessed February 12, 2023

of St. Lawrence also occurs in June and July. Most nets are fixed, except for a drift fishery in Chaleurs Bay and the part of the Gulf between New Brunswick, Prince Edward Island, and the Magdalen Islands.

Conservation harvesting plans are used to manage waved whelk in Canadian waters, which are harvested in the Gulf of St. Lawrence, Quebec, Maritimes, and Newfoundland and Labrador regions. The fishery is managed using quotas, fishing gear requirements, dockside monitoring, traps limits, seasons, tagging, and area requirements. In 2017, there were 240 whelk license holders in Quebec; however, only 81 of them were active. Whelk traps are typically weighted at the bottom with cement or other means and a rope or other mechanism is positioned in the center of the trap to secure the bait. Between 50 and 175 traps are authorized per license. The total number of authorized traps for all licenses in each fishing area varies between 550 and 6,400 traps, while the number of used or active traps is lower, with 200 to 1,700 traps per fishing area.

Since 2017, the Government of Canada has implemented measures to protect right whales from entanglement. These measures have included seasonal and dynamic closures for fixed gear fisheries, changes to the fishing season for snow crab, reductions in traps in the mid-shore fishery in Crab Fishing Area 12, and license conditions to reduce the amount of rope in the water. Measures to better track gear, require reporting of gear loss, require reporting of interactions with marine mammals, and increased surveillance for right whales have also been implemented. Measures to reduce interactions with fishing gear are adjusted annually. In 2021, mandatory closures for non-tended fixed gear fisheries, including lobster and crab, will be put in place for 15 days when right whales are sighted. If a whale is detected on days 9-15 of the closure, the closure will be extended. In the Bay of Fundy and the critical habitats in the Roseway and Grand Manan basins, this extension will be for an additional 15 days. If a right whale is detected in the Gulf of St. Lawrence, the closure will be season-long (until November 15, 2021). Outside the dynamic area, closures are considered on a case-by-case basis. There are also gear marking and reporting requirements for all fixed gear fisheries. The Government of Canada will also continue to support industry trials of innovative fishing technologies and methods to prevent and mitigate whale entanglement. This includes authorizing ropeless gear trials in closed areas in 2021. Measures to implement weak rope or weak-breaking points were delayed and will be implemented by 2024. Measures related to maximum rope diameters, sinking rope between traps and reductions in vertical and floating rope will be implemented after 2022. More information on these measures is available at <https://www.dfo-mpo.gc.ca/fisheries-peches/commercial-commercial/atl-arc/narw-bnan/management-gestion-eng.html>.

In August 2016, NMFS published the MMPA Import Provisions Rule (81 FR 54389, August 15, 2016), which established criteria for evaluating a harvesting nation's regulatory program for reducing marine mammal bycatch and the procedures for obtaining authorization to import fish and fish products into the United States. Specifically, to continue in the international trade of seafood products with the United States, other nations must demonstrate that their marine mammal mitigation measures for commercial fisheries are, at a minimum, equivalent to those in place in the United States. A five-year exemption period (beginning January 1, 2017) was created in this process to allow foreign harvesting nations time to develop, as appropriate, regulatory programs comparable in effectiveness to U.S. programs at reducing marine mammal bycatch. To comply with its requirements, it is essential that these interactions are reported, documented, and quantified. To guarantee that fish products have access to the U.S. markets, DFO must implement procedures to reliably certify that the level of mortality caused by fisheries does not exceed U.S. standards. DFO must also demonstrate that the regulations in place to reduce accidental death of marine mammals are comparable to those of the United States.

#### **5.2.4.2 Vessel Strikes in Canadian Waters**

Vessel strikes are a threat to right whales throughout their range. In Canadian waters where right whales are present, vessels include recreational and commercial vessels, small and large vessels, and sail, and power vessels. Vessel categories include oil and gas exploration, fishing and aquaculture, cruise ships, offshore

excursions (whale and bird watching), tug/tow, dredge, cargo, and military vessels. At the time of development of the Gulf of St. Lawrence management plan, approximately 6,400 commercial vessels transited the Cabot Strait and the Strait of Belle Isle annually. This represents a subset of the vessels in this area as it only includes commercial vessels (DFO 2013). To address vessel strikes in Canadian waters, the International Maritime Organization (IMO) amended the Traffic Separation Scheme in the Bay of Fundy to reroute vessels around high use areas. In 2007, IMO adopted and Canada implemented a voluntary seasonal Area to Be Avoided (ATBA) in Roseway Basin to further reduce the risk of vessel strike (DFO 2021). In addition, Canada has implemented seasonal speed restrictions and developed a proposed action plan to identify specific measures needed to address threats and achieve recovery (DFO 2021).

The Government of Canada has also implemented measures to mitigate vessel strikes in Canadian waters. Each year since August 2017, the Government has implemented seasonal speed restrictions (maximum 10 knots) for vessels 20 m or longer in the western Gulf of St. Lawrence. In 2019, the area was adjusted and the restriction was expanded to apply to vessels greater than 13 m. Smaller vessels are encouraged to respect the limit. Dynamic area management has also been used in recent years. Currently, there are two shipping lanes, south and north of Anticosti Island, where dynamic speed restrictions (mandatory slowdown to 10 knots) can be activated when right whales are present. In 2020 and 2021, the Government of Canada also implemented a trial voluntary speed restriction zone from Cabot Strait to the eastern edge of the dynamic shipping zone at the beginning and end of the season and a mandatory restricted area in or near Shediac Valley mid-season. More information is available at <https://www.tc.gc.ca/en/services/marine/navigation-marine-conditions/protecting-north-atlantic-right-whales-collisions-ships-gulf-st-lawrence.html>. Modifications to measures in 2021 include refining the size, location, and duration of the mandatory restricted area in and near Shediac Valley and expanding the speed limit exemption in waters less than 20 fathoms to all commercial fishing vessels. In 2022, a variety of measures were put in place to reduce the risk of vessel strike including vessel speed limits and restricted access areas.

### **5.2.5 Critical Habitat**

Critical habitat for NARWs has been designated in U.S. waters as described in the section of this Opinion on Species and Critical Habitat Not Likely to be Adversely Affected (Section 4).

### **5.2.6 Recovery Goals**

Recovery is the process of restoring endangered and threatened species to the point where they no longer require the safeguards of the Endangered Species Act. A recovery plan serves as a road map for species recovery—the plan outlines the path and tasks required to restore and secure self-sustaining wild populations. It is a non-regulatory document that describes, justifies, and schedules the research and management actions necessary to support recovery of a species.

The goal of the 2005 Recovery Plan for the NARW (NMFS 2005) is to promote the recovery of NARWs to a level sufficient to warrant their removal from the List of Endangered and Threatened Wildlife and Plants under the ESA. The intermediate recovery goal is to reclassify the species from endangered to threatened. The recovery strategy identified in the Recovery Plan focuses on reducing or eliminating deaths and injuries from anthropogenic activities, namely shipping and commercial fishing operations; developing demographically-based recovery criteria; the characterization, monitoring, and protection of important habitat; identification and monitoring of the status, trends, distribution and health of the species; conducting studies on the effects of other potential threats and ensuring that they are addressed, and conducting genetic studies to assess population structure and diversity. The plan also recognizes the need to work closely with state, other Federal, international and private entities to ensure that research and recovery efforts are coordinated. The recovery plan includes the

following downlisting criteria, the achievement of which would demonstrate significant progress toward full recovery:

North Atlantic right whales may be considered for reclassifying to threatened when all of the following have been met: 1) The population ecology (range, distribution, age structure, and gender ratios, etc.) and vital rates (age-specific survival, age-specific reproduction, and lifetime reproductive success) of right whales are indicative of an increasing population; 2) The population has increased for a period of 35 years at an average rate of increase equal to or greater than 2% per year; 3) None of the known threats to North Atlantic right whales (summarized in the 5 listing factors) are known to limit the population's growth rate; and 4) Given current and projected threats and environmental conditions, the right whale population has no more than a 1% chance of quasi-extinction in 100 years.

Specific criteria for delisting NARWs are not included in the recovery plan; as described in the recovery plan, conditions related to delisting are too distant and hypothetical to realistically develop specific criteria. The current abundance of NARWs is currently an order of magnitude less than an abundance at which NMFS would even consider delisting the species. The current dynamics indicate that the NARW population is in decline, rather than recovering, and decades of population growth at rates considered typical for large whales would be required before the population could attain an abundance that may suggest that delisting was appropriate to consider. Specific criteria for delisting NARWs will be included in a future revision of the recovery plan well before the population is at a level when delisting becomes a reasonable decision (NMFS 2005).

The most recent five-year review for right whales was completed in 2022 (NMFS 2022d). The recommendation in that plan was for the status to remain as endangered. As described in the report, the NARW faces continued threat of human-caused mortality due to lethal interactions with commercial fisheries and vessel traffic. As stated in the 5-Year Review, there is also uncertainty regarding the effect of long-term sublethal entanglements, emerging environmental stressors including climate change, and the compounding effects of multiple continuous stressors that may be limiting NARW calving and recovery. In addition, the NARW population has been in a state of decline since 2010. Management measures in the United States have been in place for an extended period of time and continued modifications are underway/anticipated, and measures in Canada since 2017 also suggest continued progress toward implementing conservation regulations. Despite these efforts to reduce the decline and promote recovery, progress toward right whale recovery has continued to regress.

### **5.3 Sei Whale (*Balaenoptera borealis*)**

Globally there is 1 species of sei whale, *Balaenoptera borealis borealis*. Sei whales occur in subtropical, temperate, and subpolar marine waters across the Northern and Southern Hemispheres (Figure 11; (Cooke 2018a; NMFS 2011b). For management purposes, in the Northern Hemisphere, the United States recognizes 4 sei whale stocks: Hawaii, Eastern North Pacific, and Nova Scotia (NMFS 2011b).



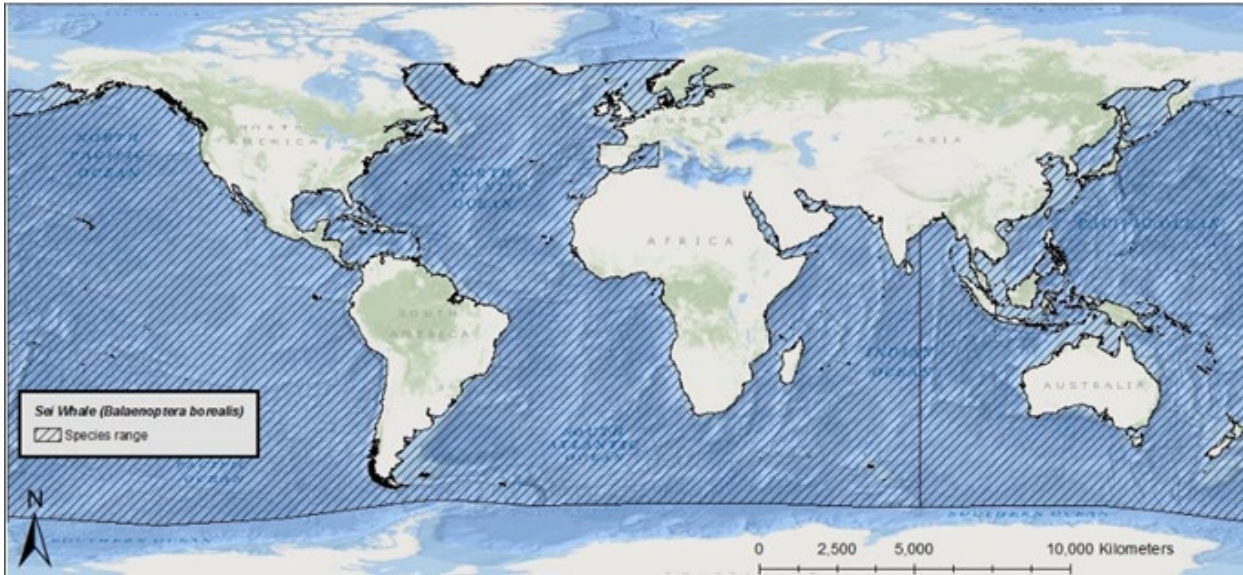

**Figure 11. Range of the sei whale**

Sei whales are distinguishable from other whales by a long, sleek body that is dark bluish-gray to black in color and pale underneath, and a single ridge located on their rostrum. The sei whale was listed as endangered on December 2, 1970 (35 FR 18319).

Information available from the recovery plan (NMFS 2011b), recent stock assessment reports (Carretta et al. 2019a; Hayes et al. 2022a; Hayes et al. 2017), 5-Year Review (NMFS 2021g), as well as the recent IUCN sei whale assessment (Cooke 2018a) were used to summarize the life history, population dynamics and status of the species as follows.

### 5.3.1 Life History

Sei whales can live, on average, between 50 and 70 years. They have a gestation period of 10 to 12 months, and calves nurse for 6 to 9 months. Sexual maturity is reached between 6 and 12 years of age with an average calving interval of 2 to 3 years. Sei whales mostly inhabit continental shelf and slope waters far from the coastline. They winter at low latitudes, where they calve and nurse, and summer at high latitudes, where they feed on a range of prey types, including: plankton (copepods and krill), small schooling fishes, and cephalopods.

### 5.3.2 Population Dynamics

There are no estimates of pre-exploitation sei whale abundance in the entire North Atlantic Ocean; however, approximately 17,000 sei whales were documented caught by modern whaling in the North Atlantic (Allison 2017). In the North Pacific, the pre-whaling sei abundance was estimated to be approximately 42,000 (Tillman 1977 as cited in NMFS 2011b). In the Southern Hemisphere, approximately 63,100 to 65,000 occurred in the Southern Hemisphere prior to exploitation (Mizroch et al. 1984b; NMFS 2011b).

In 1989, the entire North Atlantic sei whale population was estimated to be 10,300 whales (Cattanach et al. 1993 as cited in NMFS 2011b). While other surveys have been completed in portions of the North Atlantic since 1989, the survey coverage levels in these studies are not as complete as those done in Cattanach et al. (1993; Cooke 2018a). As a result, to date, updated abundance estimates for the entire North Atlantic population of sei whales are not available. However, in the western North Atlantic, Palka et al. (2017) has provided a

recent abundance estimate for the Nova Scotia stock of sei whales. Based on survey data collected from Halifax, Nova Scotia, to Florida between 2010 and 2013, it is estimated that there are approximately 6,292 sei whales ( $N_{\min}=3,098$ ; Palka et al. 2017); this estimate is considered the best available scientific information for the Nova Scotia stock (NMFS 2021g). In the North Pacific, an abundance estimate for the entire North Pacific population of sei whales is not available. However, in the western North Pacific, it is estimated that there are 35,000 sei whales (Cooke 2018a). In the eastern North Pacific (considered east of longitude 180°), 2 stocks of sei whales occur in U.S. waters: Hawaii and Eastern North Pacific. Abundance estimates for the Hawaii stock are 391 sei whales ( $N_{\min}=204$ ), and for Eastern North Pacific stock, 519 sei whales ( $N_{\min}=374$ ; Carretta et al. 2019a). In the Southern Hemisphere, recent abundance of sei whales is estimated at 9,800 to 12,000 whales. Population growth rates for sei whales are not available at this time as there are little to no systematic survey efforts to study sei whales; however, in U.S. waters, NMFS has determined that until additional data is available, the cetacean maximum theoretical net productivity rate of 4.0% will be used for the Hawaii, Eastern North Pacific, and Hawaii stocks of sei whales (Hayes et al. 2019).

Based on genetic analyses, there appears to be some differentiation between sei whale populations in different ocean basins. In an early analysis of genetic variation in sei whales, some differences between Southern Ocean and the North Pacific sei whales were detected (Wada and Numachi 1991). However, more recent analyses of mitochondrial DNA control region variation show no significant differentiation between Southern Ocean and the North Pacific sei whales, though both appear to be genetically distinct from sei whales in the North Atlantic (Huijser et al. 2018). Within each ocean basin, there appears to be intermediate to high genetic diversity and little genetic differentiation despite there being different managed stocks (Danielsdottir et al. 1991; Kanda et al. 2011; Kanda et al. 2006; Kanda et al. 2015; Kanda et al. 2013).

### **5.3.3 Status**

The sei whale is endangered because of past commercial whaling. Now, only a few individuals are taken each year by Japan. Current threats include vessel strikes, fisheries interactions (including entanglement), climate change (habitat loss and reduced prey availability), and anthropogenic sound. Given the species' overall abundance, they may be somewhat resilient to current threats. However, trends are largely unknown, especially for individual stocks, many of which have relatively low abundance estimates. The most recent 5-year average human-caused mortality and serious injury rate for sei whales in the North Atlantic is 0.80 (0.4 incidental fishery interactions, 0.2 vessel collisions, 0.2 other human-caused mortality; Hayes et al. 2022). These represent a minimum estimate of human-caused mortality, which is almost certainly biased low.

### **5.3.4 Critical Habitat**

No critical habitat has been designated for the sei whale.

### **5.3.5 Recovery Goals**

The 2011 Recovery Plan for the sei whale (NMFS 2011b) indicates that, “because the current population status of sei whales is unknown, the primary purpose of this Recovery Plan is to provide a research strategy to obtain data necessary to estimate population abundance, trends, and structure and to identify factors that may be limiting sei whale recovery.” The goal of the Recovery Plan is to promote the recovery of sei whales to the point at which they can be downlisted from Endangered to Threatened status, and ultimately to remove them from the list of Endangered and Threatened Wildlife and Plants, under the provisions of the ESA. The intermediate goal is to reclassify the species from endangered to threatened. The recovery plan incorporates an adaptive management strategy that divides recovery actions into 3 tiers. Tier I involves: 1) continued international regulation of whaling (i.e., a moratorium on commercial sei whaling); 2) determining population



size, trends, and structure using opportunistic data collection in conjunction with passive acoustic monitoring, if determined to be feasible; and 3) continued stranding response and associated data collection.

NMFS completed the most recent five-year review for sei whales in 2021 (NMFS 2021g). In that review, NMFS concluded that the listing status should remain unchanged. They also concluded that recovery criteria outlined in the sei whale recovery plan (NMFS 2011b) do not reflect the best available and most up-to date information on the biology of the species. The 5-Year review states that currently, there is insufficient data to undertake an assessment of the sei whale's present status due to a number of uncertainties and unknowns for this species: (1) lack of scientifically reliable population estimates for the North Atlantic and Southern Hemisphere; (2) lack of comprehensive information on status and trends; (3) existence of critical knowledge gaps; and (4) emergence of potential new threats. Thus, further research is needed to fill critical knowledge gaps.

#### 5.4 Sperm Whale (*Physeter macrocephalus*)

Globally there is 1 species of sperm whale, *Physeter macrocephalus*. Sperm whales occur in all major oceans of the Northern and Southern Hemispheres (NMFS 2010b; Figure 12). For management purposes, in the Northern Hemisphere, the United States recognizes 6 sperm whale stocks: California/Oregon/Washington, Hawaii, North Pacific, North Atlantic, Northern Gulf of Mexico, and Puerto Rico and the U.S. Virgin Islands (NMFS 2010d); see NMFS Marine Mammal Stock Assessment Reports: <https://www.fisheries.noaa.gov/national/marine-mammal-protection/marine-mammal-stock-assessment-reports-species-stock>.



Figure 12. Range of the sperm whale

In the western North Atlantic, sperm whales range from Greenland south into the Gulf of Mexico and the Caribbean, where they are common, especially in deep basins off of the continental shelf (Romero et al. 2001; Wardle et al. 2001). Sperm whales are the most common large whale in the northern Gulf of Mexico, found throughout this area year-round (Fulling et al. 2003; Maze-Foley and Mullin 2006; Mullin and Fulling 2004; Mullin and Hoggard 2000; Mullin et al. 2004; Mullin et al. 1994), with particularly high concentrations along the continental slope in or near cyclonic cold-core eddies due to enhanced productivity (Davis et al. 2007; O'herm and Biggs 2009; Palka and Johnson 2007). Aerial surveys confirm that sperm whales are present in the northern Gulf of Mexico in all seasons (Mullin et al. 1994).

Sperm whales have a strong preference for waters deeper than 1,000 m (Reeves and Whitehead 1997; Watkins 1977), and they are rarely found in waters less than 300 m in depth (Clarke 1956; Rice 1989). When they are found closer to shore, it is usually associated with sharp increases in topography where upwelling occurs and biological production is high, indicating the presence of a good food supply (Clarke 1956). Such areas include oceanic islands and along the outer continental shelf.

The sperm whale is the largest toothed whale and distinguishable from other whales by its extremely large head, which takes up 25 to 35% of its total body length and a single blowhole asymmetrically situated on the left side of the head near the tip. The sperm whale was originally listed as endangered on December 2, 1970 (35 FR 18319).

Information available from the recovery plan (NMFS 2010d), recent stock assessment reports (Carretta et al. 2018; Hayes et al. 2020; Muto et al. 2019), status review (NMFS 2015c), as well as the recent IUCN sperm whale assessment (Taylor et al. 2019) were used to summarize the life history, population dynamics and status of the species as follows.

#### **5.4.1 Life History**

The average lifespan of sperm whales is estimated to be at least 50 years (Whitehead 2009). They have a gestation period of 1 to 1 and a half years, and calves nurse for approximately 2 years, though they may begin to forage for themselves within the first year of life (Tønnesen et al. 2018). Sexual maturity is reached between 7 and 13 years of age for females with an average calving interval of 4 to 6 years. Male sperm whales reach full sexual maturity in their 20s. Sperm whales mostly inhabit areas with a water depth of 600 m or more, and are uncommon in waters less than 300 m deep. They winter at low latitudes, where they calve and nurse, and summer at high latitudes, where they feed primarily on squid; other prey includes octopus and demersal fish (including teleosts and elasmobranchs).

#### **5.4.2 Population Dynamics**

Pre-whaling, the global population of sperm whales was estimated to be approximately 1,100,000 animals (Taylor et al. 2019; Whitehead 2002). By 1880, due to whaling, the population was approximately 71% of its original level (Whitehead 2002). In 1999, ten years after the end of large-scale whaling, the population was estimated to be about 32% of its original level (Whitehead 2002).

The most recent global sperm whale population estimate is 360,000 whales (Whitehead 2009). There are no reliable estimates for sperm whale abundance across the entire (North and South) Atlantic Ocean. However, estimates are available for 2 of 3 U.S. stocks in the western North Atlantic Ocean; the Northern Gulf of Mexico stock is estimated to consist of 763 individuals ( $N_{\min}=560$ ; Waring et al. 2016) and the North Atlantic stock is estimated to consist of 4,349 individuals ( $N_{\min}=3,451$ ; Hayes et al. 2019). There are insufficient data to estimate abundance for the Puerto Rico and U.S. Virgin Islands stock. Similar to the Atlantic Ocean, there are no reliable estimates for sperm whale abundance across the entire (North and South) Pacific Ocean. However, estimates are available for 2 of 3 U.S. stocks that occur in the eastern Pacific; the California/Oregon/ Washington stock is estimated to consist of 1,997 individuals ( $N_{\min}=1,270$ ; Carretta et al. 2019b), and the Hawaii stock is estimated to consist of 4,559 individuals ( $N_{\min}=3,478$ ; Carretta et al. 2019a). We are aware of no reliable abundance estimates for sperm whales in other major oceans in the Northern and Southern Hemispheres. Although maximum net productivity rates for sperm whales have not been clearly defined, population growth rates for sperm whale populations are expected to be low (i.e., no more than 1.1% per year; Whitehead 2002). In U.S. waters, NMFS determined that, until additional data is available, the cetacean maximum theoretical net productivity rate of 4.0% will be used for, among others, the North Atlantic, Northern Gulf of Mexico, and

Puerto Rico and the U.S. Virgin Islands stocks of sperm whales (Carretta et al. 2019a; Carretta et al. 2019b; Hayes et al. 2019; Muto et al. 2019; Waring et al. 2010; Waring et al. 2016).

Ocean-wide genetic studies indicate sperm whales have low genetic diversity, suggesting a recent bottleneck, but strong differentiation between matrilineally related groups (Lyrholm and Gyllensten 1998). Consistent with this, 2 studies of sperm whales in the Pacific Ocean indicate low genetic diversity (Mesnick et al. 2011; Rendell et al. 2012). Furthermore, sperm whales from the Gulf of Mexico, the western North Atlantic Ocean, the North Sea, and the Mediterranean Sea all have been shown to have low levels of genetic diversity (Engelhaupt et al. 2009). As none of the stocks for which data are available have high levels of genetic diversity, the species may be at some risk to inbreeding and ‘allee’ effects (i.e., Allee effects are broadly characterized as a decline in individual fitness in populations with a small size or density), although the extent to which is currently unknown. Sperm whales have a global distribution and can be found in relatively deep waters in all ocean basins. While both males and females can be found in latitudes less than 40 degrees, only adult males venture into the higher latitudes near the poles.

### 5.4.3 Status

The sperm whale is endangered as a result of past commercial whaling. Although the aggregate abundance worldwide is probably at least several hundred thousand individuals, the extent of depletion and degree of recovery of populations are uncertain. Commercial whaling is no longer allowed, however, illegal hunting may occur. Continued threats to sperm whale populations include vessel strikes, entanglement in fishing gear, competition for resources due to overfishing, loss of prey and habitat due to climate change, and sound. The Deepwater Horizon Natural Resource Damage Assessment Trustees assessed effects of oil exposure on sea turtles and marine mammals. Sperm whales in the Gulf of Mexico were impacted by the oil spill with 3% of the stock estimated to have died (Westerholm and Rauch 2016). The most recent SAR for sperm whales in the North Atlantic notes that there were no documented reports of fishery-related mortality or serious injury to the North Atlantic stock in the U.S. EEZ during 2013–2017 (Hayes et al. 2020); there are also no reports in NMFS records from 2018-2023. The species’ large population size shows that it is somewhat resilient to current threats.

### 5.4.4 Critical Habitat

No critical habitat has been designated for the sperm whale.

### 5.4.5 Recovery Goals

The goal of the Recovery Plan is to promote recovery of sperm whales to a point at which they can be downlisted from endangered to threatened status, and ultimately to remove them from the list of Endangered and Threatened Wildlife and Plants, under the provisions of the ESA. The primary purpose of the Recovery Plan is to identify and take actions that will minimize or eliminate effects of human activities that are detrimental to the recovery of sperm whale populations. Immediate objectives are to identify factors that may be limiting abundance, recovery, and/or productivity, and cite actions necessary to allow the populations to increase. The Recovery Plan includes downlisting and delisting criteria (NMFS 2010d).

The most recent Five-Year Review for sperm whales was completed in 2015 (NMFS 2015c). In that review, NMFS concluded that no change to the listing status was recommended.

## 5.5 Green Sea Turtle (*Chelonia mydas*, North Atlantic DPS)

The green turtle was listed under the ESA on July 28, 1978 (43 FR 32800). The species was separated into 2 ESA-listing designations: endangered for breeding populations in Florida and the Pacific coast of Mexico and

threatened in all other areas throughout its range. On April 6, 2016, NMFS listed 11 DPSs of green sea turtles as threatened or endangered under the ESA (81 FR 20057).

The North Atlantic DPS of green turtle, which is the only DPS that overlaps with the action area, is ESA-listed as threatened. The North Atlantic DPS of green turtle is found in the North Atlantic Ocean and Gulf of Mexico. Green turtles from the North Atlantic DPS range from the boundary of South and Central America (7.5° N, 77° W) in the south, throughout the Caribbean, the Gulf of Mexico, and the U.S. Atlantic coast to New Brunswick, Canada (48° N, 77° W) in the north (Figure 13). The range of the DPS then extends due east along latitudes 48° N and 19° N to the western coasts of Europe and Africa. Nesting occurs primarily in Costa Rica, Mexico, Florida, and Cuba.

The green turtle is globally distributed and commonly inhabits nearshore and inshore waters, occurring throughout tropical, sub-tropical and, to a lesser extent, temperate waters (Seminoff et al. 2015a). The green turtle is the largest of the hard-shell marine turtles, growing to a weight of approximately 350 lbs. (159 kg) and a straight carapace length of greater than 3.3 ft (1 m), while hatchlings are just 2 inches (50 millimeters [mm]) long.

Green turtles have a smooth carapace with 4 pairs of lateral (or costal) scutes and a single pair of elongated prefrontal scales between the eyes. They typically have a black dorsal surface and a white ventral surface, although the carapace of green turtles in the Atlantic Ocean has been known to change in color from solid black to a variety of shades of gray, green, or brown and black in starburst or irregular patterns (Lagueux 2001). Adult green turtles are unique among sea turtles in that they are herbivorous, feeding primarily on sea grasses and algae. This diet is thought to give them greenish colored fat from which they take their name.

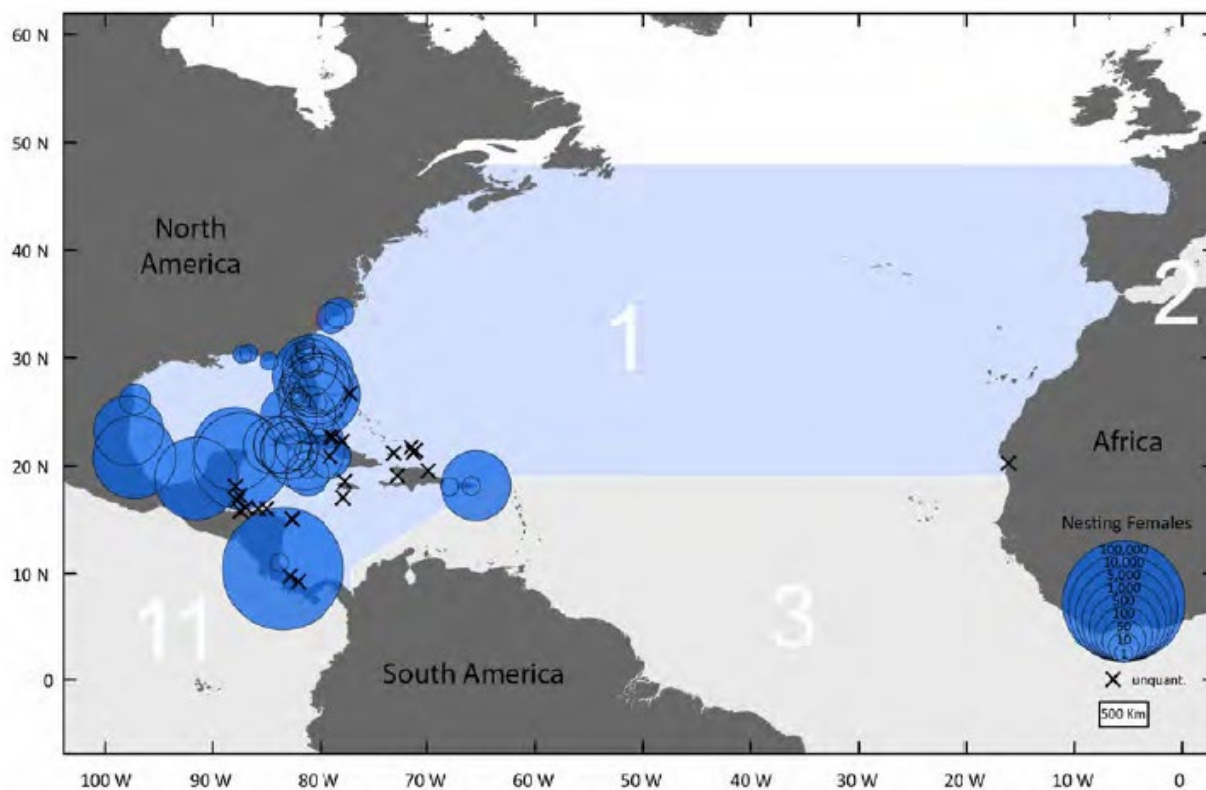

**Figure 13. Geographic range of the North Atlantic DPS of green turtles, with location and abundance of nesting females (Seminoff et al. 2015a)**

We used information available in the 2015 Status Review (Seminoff et al. 2015a), relevant literature, and recent nesting data from the Florida Fish and Wildlife Conservation Commission's Fish and Wildlife Research Institute (FWRI) to summarize the life history, population dynamics and status of the species, as follows.

**5.5.1 Life History**

Sea turtles are long-lived animals. Size and age at sexual maturity have been estimated using several methods, including mark-recapture, skeletochronology, and marked known-aged individuals. Estimates vary widely among studies and populations, and methods continue to be developed and refined (Avens and Snover 2013). Early mark-recapture studies in Florida estimated the age at sexual maturity 18-30 years (Frazer and Ehrhart 1985; Goshe et al. 2010; Mendonca 1981). More recent estimates of age at sexual maturity are as high as 35–50 years (Avens and Snover 2013; Goshe et al. 2010), with lower ranges reported from known age (15–19 years) turtles from the Cayman Islands (Bell et al. 2005) and Caribbean Mexico (12–20 years; Zurita et al. 2012). A study of green turtles that use waters of the southeastern United States as developmental habitat found the age at sexual maturity likely ranges from 30 to 44 years (Goshe et al. 2010). Green turtles in the Northwestern Atlantic mature at 2.8-33+ ft (85–100+ centimeters [cm]) straight carapace lengths (SCL; Avens and Snover 2013).

Costa Rica (Tortuguero), Mexico (Campeche, Yucatan, Quintana Roo), United States (Florida) and Cuba support nesting concentrations of particular interest in the North Atlantic DPS (Seminoff et al. 2015a). The largest nesting site in the North Atlantic DPS is in Tortuguero, Costa Rica, which hosts 79% of nesting females for the DPS (Seminoff et al. 2015a). In the southeastern United States, females generally nest between May and September (Seminoff et al. 2015a; Witherington et al. 2006). Green sea turtles lay an average of 3 nests per season with an average of 1 hundred eggs per nest (Hirth 1997; Seminoff et al. 2015a). The remigration interval (period between nesting seasons) is 2 to 5 years (Hirth 1997; Seminoff et al. 2015a). Nesting occurs primarily on beaches with intact dune structure, native vegetation, and appropriate incubation temperatures during the summer months.

After emerging from the nest, hatchlings swim to offshore areas and go through a post-hatchling pelagic stage where they are believed to live for several years. During this life stage, green turtles feed close to the surface on a variety of marine algae and other life associated with drift lines and debris. Adult sea turtles exhibit site fidelity and migrate hundreds to thousands of kilometers from nesting beaches to foraging areas. Green turtles spend the majority of their lives in coastal foraging grounds, which include open coastlines and protected bays and lagoons. Adult green turtles feed primarily on seagrasses and algae, although they also eat jellyfish, sponges, and other invertebrate prey (Seminoff et al. 2015a).

**5.5.2 Population Dynamics**

The North Atlantic DPS of green turtle has a unique haplotype, which was a factor in defining the discreteness of the population for the DPS. Evidence from mitochondrial DNA studies indicates that there are at least 4 independent nesting sub-populations in Florida, Cuba, Mexico, and Costa Rica (Seminoff et al. 2015a). More recent genetic analysis indicates that designating a new western Gulf of Mexico management unit might be appropriate (Shamblin et al. 2016).

The green sea turtle occupies the coastal waters of over 140 countries worldwide; nesting occurs in more than 80 countries. Our knowledge of sea turtle population dynamics, status, and trends is inferred from shifts in the abundance of females returning to their natal beach for nesting. Worldwide, nesting data at 464 sites indicate that 563,826 to 564,464 females nest each year (Seminoff et al. 2015a). Compared to other DPSs, the North



Atlantic DPS exhibits the highest nester abundance, with approximately 167,424 females at 73 nesting sites, and available data indicate an increasing trend in nesting (Seminoff et al. 2015a). Counts of nests and nesting females are commonly used as an index of abundance and population trends, even though there are doubts about the ability to estimate the overall population size. The largest nesting site in the North Atlantic DPS is in Tortuguero, Costa Rica, which hosts 79% of nesting females for the DPS (Seminoff et al. 2015a).

There are no reliable estimates of population growth rate for the DPS as a whole, but estimates have been developed at a localized level. The status review for green sea turtles assessed population trends for 7 nesting sites with more than 10 years of data collection in the North Atlantic DPS. The results were variable with some sites showing no trend and others increasing. However, all major nesting populations (using data through 2011-2012) demonstrated increases in abundance (Seminoff et al. 2015a).

Recent data is available for the southeastern United States. The FWRI monitors sea turtle nesting through the Statewide Nesting Beach Survey (SNBS) and Index Nesting Beach Survey (INBS). Since 1979, the SNBS has surveyed approximately 215 beaches to collect information on the distribution, seasonality, and abundance of sea turtle nesting in Florida. Since 1989, the INBS has been conducted on a subset of SNBS beaches to monitor trends through consistent effort and specialized training of surveyors. The INBS data uses a standardized data-collection protocol to allow for comparisons between years and is presented for green, loggerhead, and leatherback sea turtles. The index counts represent 27 core index beaches and do not represent Florida's total annual nest counts because they are collected only on a subset of Florida's beaches (27 out of 224 beaches) and only during a 109-day time window (15 May through 31 August). The index nest counts represent approximately 67% of known green turtle nesting in Florida (<https://myfwc.com/research/wildlife/sea-turtles/nesting/beach-survey-totals/>).

Green turtle nest counts have increased eightyfold since standardized nest counts began in 1989 (Figure 14). In 2021, green turtle nest counts on the 27-core index beaches reached more than 24,000 nests recorded. Nesting green turtles tend to follow a two-year reproductive cycle and, typically, there are wide year-to-year fluctuations in the number of nests recorded. Green turtles set record highs in 2011, 2013, 2015, 2017, and 2019. The nest count in 2021 did not set another record high but was only marginally higher than 2020, an unusually high "low year." FWRI reports that changes in the typical two-year cycle have been documented in the past as well (e.g., 2010-2011) and are not reason of concern.

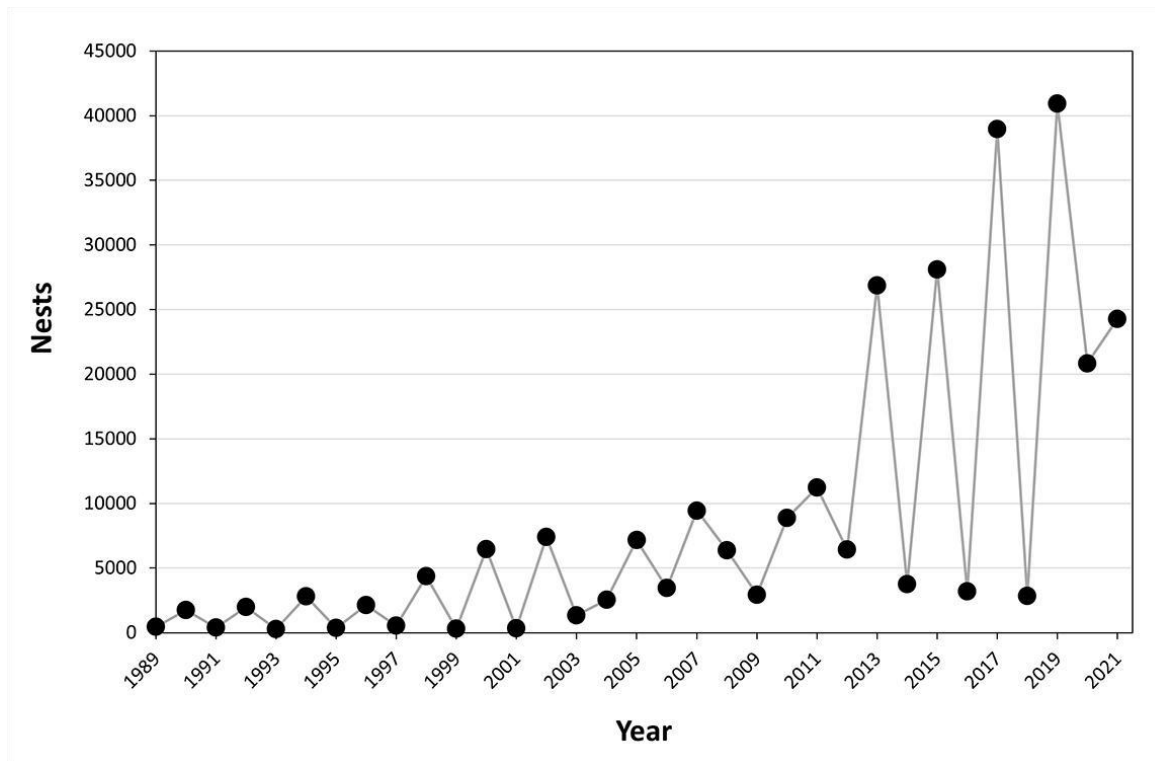

Figure 14. Number of green sea turtle nests counted on core index beaches in Florida from 1989-2021 (<https://myfwc.com/research/wildlife/sea-turtles/nesting/beach-survey-totals/>)

### 5.5.3 Status

Once abundant in tropical and sub-tropical waters worldwide, green turtles exist at a fraction of their historical abundance as a result of over-exploitation. Globally, egg harvest, the harvest of females on nesting beaches, and directed hunting of sea turtles in foraging areas remain the 3 greatest threats to their recovery. In addition, bycatch in drift-net, long-line, set-net, pound-net, and trawl fisheries kill thousands of green turtles annually. Increasing coastal development (including beach erosion and re-nourishment, construction and artificial lighting) threatens nesting success and hatchling survival. On a regional scale, the different DPSs experience these threats as well, to varying degrees. Differing levels of abundance combined with different intensities of threats and effectiveness of regional regulatory mechanisms make each DPS uniquely susceptible to future perturbations.

Historically, green sea turtles in the North Atlantic DPS were hunted for food, which was the principal cause of the population's decline. Apparent increases in nester abundance for the North Atlantic DPS in recent years are encouraging but must be viewed cautiously, as the datasets represent a fraction of a green turtle generation, which is between 30 and 40 years, up to 50 years. While the threats of pollution, habitat loss through coastal development, beachfront lighting, and fisheries bycatch continue, the North Atlantic DPS appears to be somewhat resilient to future perturbations (Seminoff et al. 2015a).

### 5.5.4 Critical Habitat

Critical habitat for the North Atlantic DPS of green sea turtles surrounds Culebra Island, Puerto Rico (66 FR 20058, April 6, 2016), which is outside the action area. On July 19, 2023, NMFS published a proposed rule to designate specific areas in the marine environment as critical habitat for six DPSs of the green sea turtle,

including the North Atlantic DPS (88 FR 46572). The proposed critical habitat includes 4 types of physical and biological features: reproductive, migratory, benthic foraging/resting, and surface-pelagic foraging/resting (“*Sargassum*”). Proposed critical habitat for the North Atlantic DPS of green sea turtles includes areas on the coasts of North Carolina, Florida, Texas, and Puerto Rico, as well as larger areas in the Atlantic and Gulf of Mexico when *Sargassum* habitat occurs.

### 5.5.5 Recovery Goals

The most recent Recovery Plan for the U.S. population of green sea turtles in the Atlantic was published in 1991. The goal of the 1991 Recovery Plan is to delist the species once the recovery criteria are met (NMFS 1991). The recovery plan includes criteria for delisting related to nesting activity, nesting habitat protection, and reduction in mortality. Priority actions to meet the recovery goals include:

1. Providing long-term protection to important nesting beaches.
2. Ensuring at least a 60% hatch rate success on major nesting beaches.
3. Implementing effective lighting ordinances/plans on nesting beaches.
4. Determining distribution and seasonal movements of all life stages in the marine environment.
5. Minimizing commercial fishing mortality.
6. Reducing threat to the population and foraging habitat from marine pollution.

### 5.6 Leatherback Sea Turtle (*Deromchelys coriacea*)

The leatherback turtle is unique among sea turtles for its large size, wide distribution (due to thermoregulatory systems and behavior), and lack of a hard, bony carapace. Leatherback turtles are the largest living sea turtle, reaching lengths of 1.8 m long, and weighing up to 1 ton. Leatherback turtles have a distinct black leathery skin covering their carapace with pinkish white skin on their belly.

The leatherback turtle has the most extensive global distribution of any reptile and is distributed from tropical to sub-polar latitudes, worldwide (Figure 15). Leatherback turtles spend the majority of their lives at sea, where they develop, forage, migrate, and mate, nesting on beaches on every continent except Europe and Antarctica, and several islands of the Caribbean and the Indo-Pacific (Eckert et al. 2012; NMFS and USFWS 2020). Seven populations are currently recognized: (1) Northwest Atlantic; (2) Southeast Atlantic; (3) Southwest Atlantic; (4) Northeast Indian; (5) Southwest Indian; (6) West Pacific; and (7) East Pacific Ocean populations (NMFS and USFWS 2020). For purposes of this Opinion, we focus on the Northwest Atlantic population.



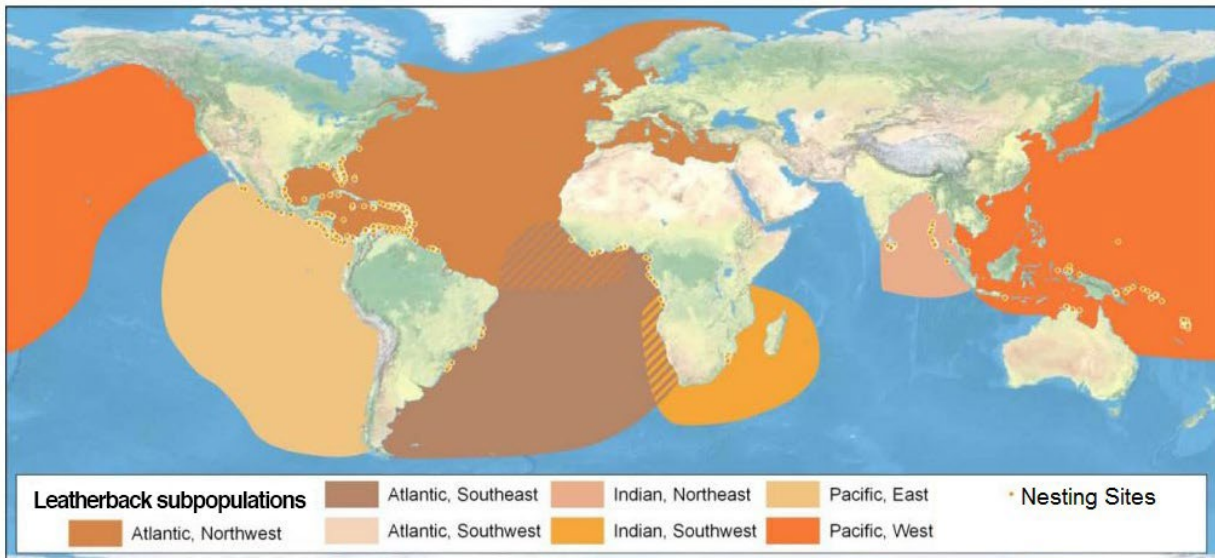

**Figure 15. Range of endangered leatherback turtle; adapted from Wallace et al. 2013**

Leatherback sea turtles are listed as endangered under the ESA throughout their global range. The species was first listed under the Endangered Species Conservation Act and listed as endangered under the ESA since 1973. In 2020, seven leatherback populations that met the discreteness and significance criteria of the distinct population segment policy were identified (NMFS and USFWS 2020). The population found within the action area is the Northwest Atlantic population segment (NW Atlantic). NMFS and USFWS concluded that the seven populations, which met the criteria for DPSs, all met the definition of an endangered species. However, NMFS and USFWS determined that the listing of DPSs was not warranted; leatherbacks continue to be listed at the global level (85 FR 48332, August 10, 2020). Therefore, information is presented on the range-wide status. We used information available in the five-year review (NMFS and USFWS 2013b), the critical habitat designation (44 FR 17710, March 23, 1979), the most recent status review (NMFS and USFWS 2020), relevant literature, and recent nesting data from the Florida FWRI to summarize the life history, population dynamics and status of the species, as follows.

### 5.6.1 Life History

Leatherbacks are a long-lived species that delay age of maturity, have low and variable survival in the egg and juvenile stages, and have relatively high and constant annual survival in the subadult and adult life stages (Heppell et al. 2003; Spotila et al. 1996; Spotila et al. 2000). While a robust estimate of the leatherback sea turtle's life span does not exist, the current best estimate for the maximum age is 43 (Avens et al. 2009). It is still unclear when leatherbacks first become sexually mature, with estimates ranging from 5 to 29 years (Avens et al. 2009; Spotila et al. 1996).

Preferred nesting grounds are in the tropics; though, nests span latitudes from 34 °S in western Cape, South Africa to 38 °N in Maryland (Eckert 2012) (Eckert et al. 2015). Females lay an average of 5 to 7 clutches (range: 1-14 clutches) per season, with 20 to over 100 eggs per clutch and eggs weighing greater than 80 grams (Eckert et al. 2012; Reina et al. 2002; Wallace et al. 2007). The average clutch frequency for the Northwest Atlantic population segment is 5.5 clutches per season (NMFS and USFWS 2020). In the western Atlantic, leatherbacks lay about 82 eggs per clutch. Remigration intervals are 2-4 years for most populations (range 1-11 years; Eckert et al. 2015; NMFS and USFWS 2020); the remigration interval for the Northwest Atlantic population segment is approximately 3 years (NMFS and USFWS 2020). The number of leatherback hatchlings

that make it out of the nest on to the beach (i.e., emergence success) is approximately 50% worldwide (Eckert et al. 2012).

The number of leatherback turtle hatchlings that make it out of the nest on the beach (i.e., emergent success) is approximately 50% worldwide (Eckert et al. 2012). Eggs hatch after 60 to 65 days, and the hatchlings have white striping along the ridges of their backs and on the edges of the flippers. Leatherback hatchlings weigh approximately 1.5 to 2 ounces (40 to 50 grams), and are approximately 2 to 3 inches (51 to 76 mm) in length, with fore flippers as long as their bodies. Hatchlings grow rapidly with reported growth rates for leatherbacks from 2.5 to 27.6 inches (six to 70 cm) in length, estimated at 12.6 inches (32 cm) per year (Jones et al. 2011). Females nest every 1 to 7 years. Natal homing, at least within an ocean basin, results in reproductive isolation between 5 broad geographic regions: eastern and western Pacific, eastern and western Atlantic, and Indian Ocean.

Age at sexual maturity has been challenging to obtain given the species physiology and habitat use (Avens et al. 2019). Past estimates ranged from 5-29 years (Avens et al. 2009; Spotila et al. 1996). More recently, Avens et al. (2020) used refined skeletochronology to assess the age at sexual maturity for leatherback sea turtles in the Atlantic and the Pacific. In the Atlantic, the mean age at sexual maturity was 19 years (range 13-28) and the mean size at sexual maturity was 4.2 ft (129.2 cm) CCL (range 3.7-5 ft [112.8-153.8 cm]). In the Pacific, the mean age at sexual maturity was 17 years (range 12-28) and the mean size at sexual maturity was 4.2 ft (129.3 cm) CCL (range 3.6- 5 ft [110.7-152.3 cm]; Avens et al. 2019).

Leatherbacks have a greater tolerance for colder waters compared to all other sea turtle species due to their thermoregulatory capabilities (Paladino et al. 1990; Shoop and Kenney 1992; Wallace and Jones 2008). Evidence from tag returns, satellite telemetry, and strandings in the western Atlantic suggests that adult leatherback sea turtles engage in routine migrations between temperate/boreal and tropical waters (Bond and James 2017; Dodge et al. 2015; Eckert 2006; James et al. 2005a; James et al. 2005b; James et al. 2005c). Tagging studies collectively show a clear separation of leatherback movements between the North and South Atlantic Oceans (NMFS and USFWS 2020).

Leatherback sea turtles undertake the longest migrations of any sea turtle, migrating long, transoceanic distances between their tropical nesting beaches and the highly productive temperate waters where they forage. During migrations or long distance movements, leatherbacks maximize swimming efficiency by traveling within 15 ft of the surface (Eckert 2002).

Leatherback sea turtles feed primarily on gelatinous zooplankton such as cnidarians (jellyfish and siphonophores) and tunicates (salps and pyrosomas; Bjorndal 1997; USFWS 1998). These gelatinous prey are relatively nutrient-poor, such that leatherback turtles must consume large quantities to support their body weight and energetic needs. Leatherback sea turtles feed from near the surface to depths exceeding 1,000 m, including nocturnal feeding on tunicate colonies within the deep scattering layer (Spotila 2004). Although leatherback sea turtles can dive deeper than any other reptile, most foraging dives are less than 80 m (Shillinger et al. 2011). Leatherback turtles weigh about 33% more on their foraging grounds than at nesting, indicating that they probably catabolize fat reserves to fuel migration and subsequent reproduction (Aguirre et al. 2006; James et al. 2005b; Wallace et al. 2006). Studies on the foraging ecology of leatherbacks in the North Atlantic show that leatherbacks off Massachusetts primarily consumed lion's mane, sea nettles, and ctenophores (Dodge et al. 2011). Juvenile and small subadult leatherbacks may spend more time in oligotrophic (relatively low plant nutrient usually accompanied by high dissolved oxygen) open ocean waters where prey is more difficult to find (Dodge et al. 2011). Sea turtles must meet an energy threshold before returning to nesting beaches. Therefore, their remigration intervals (the time between nesting) are dependent upon foraging success and duration (Hays 2000; Price et al. 2004).

## 5.6.2 Population Dynamics

Leatherback distribution is global, with nesting beaches in the Pacific, Atlantic, and Indian Oceans. Leatherbacks occur throughout marine waters, from nearshore habitats to oceanic environments (NMFS and USFWS 2020; Shoop and Kenney 1992). Movements are largely dependent upon reproductive and feeding cycles and the oceanographic features that concentrate prey, such as frontal systems, eddy features, current boundaries, and coastal retention areas (Benson et al. 2011).

Analyses of mtDNA from leatherback sea turtles indicates a low level of genetic diversity (Dutton et al. 1999). Further analysis of samples taken from individuals from rookeries in the Atlantic and Indian Oceans suggest that each of the rookeries represent demographically independent populations (NMFS and USFWS 2013b). Using genetic data,, combined with nesting, tagging, and tracking data, researchers identified seven global regional management units (RMU) or subpopulations: Northwest Atlantic, Southeast Atlantic, Southwest Atlantic, Northwest Indian, Southwest Indian, East Pacific, and West Pacific (Wallace et al. 2010). The status review concluded that the RMUs identified by (Wallace et al. 2010) are discrete populations and, then, evaluated whether any other populations exhibit this level of genetic discontinuity (NMFS and USFWS 2020).

To evaluate the RMUs and fine-scale structure in the Atlantic, Dutton et al. (2013) conducted a comprehensive genetic re-analysis of rookery stock structure. Samples from eight nesting sites in the Atlantic and one in the southwest Indian Ocean identified seven management units in the Atlantic and revealed fine scale genetic differentiation among neighboring populations. The mtDNA analysis failed to find significant differentiation between Florida and Costa Rica or between Trinidad and French Guiana/Suriname (Dutton et al. 2013). While Dutton et al. (2013) identified fine-scale genetic partitioning in the Atlantic Ocean, the differences did not rise to the level of marked separation or discreteness (NMFS and USFWS 2020). Other genetic analyses corroborate the conclusions of Dutton et al. (2013). These studies analyzed nesting sites in French Guiana (Molfetti et al. 2013), nesting and foraging areas in Brazil (Vargas et al. 2019), and nesting beaches in the Caribbean (Carreras et al. 2013). These studies all support three discrete populations in the Atlantic (NMFS and USFWS 2020). While these studies detected fine-scale genetic differentiation in the NW, SW, and SE Atlantic populations, the status review team determined that none indicated that the genetic differences were sufficient to be considered marked separation (NMFS and USFWS 2020).

Population growth rates for leatherback sea turtles vary by ocean basin. An assessment of leatherback populations through 2010 found a global decline overall (Wallace et al. 2013). Using datasets with abundance data series that are 10 years or greater, they estimated that leatherback populations have declined from 90,599 nests per year to 54,262 nests per year over three generations ending in 2010 (Wallace et al. 2013).

Several more recent assessments have been conducted. The Northwest Atlantic Leatherback Working Group (NALWG) was formed to compile nesting abundance data, analyze regional trends, and provide conservation recommendations. The IUCN Red List assessment for the Northwest Atlantic Ocean subpopulation estimated 20,000 mature individuals and approximately 23,000 nests per year (estimate to 2017; NALWG 2019). Annual nest counts show high inter-annual variability within and across nesting sites (NALWG 2018). Using data from 24 nesting sites in 10 nations within the Northwest Atlantic population segment, the leatherback status review estimated that the total index of nesting female abundance for the Northwest Atlantic population segment is 20,659 females (NMFS and USFWS 2020). This estimate only includes nesting data from recently and consistently monitored nesting beaches. An index (rather than a census) was developed given that the estimate is based on the number of nests on main nesting beaches with recent and consistent data and assumes a 3-year remigration interval. This index provides a minimum estimate of nesting female abundance (NMFS and USFWS 2020). This index of nesting female abundance is similar to other estimates. The TEWG estimated approximately 18,700 (range 10,000 to 31,000) adult females using nesting data from 2004 and 2005 (TEWG

2007b). As described above, the IUCN Red List Assessment estimated 20,000 mature individuals (male and female). The estimate in the status review is higher than the estimate for the IUCN Red List assessment, likely due to a different remigration interval, which has been increasing in recent years (NMFS and USFWS 2020).

Previous assessments of leatherbacks concluded that the Northwest Atlantic population was stable or increasing (NALWG 2019; TEWG 2007b). However, based on more recent analyses, leatherback nesting in the Northwest Atlantic is showing an overall negative trend, with the most notable decrease occurring during the most recent period of 2008-2017 (NALWG 2018). The analyses for the IUCN Red List assessment indicate that the overall regional, abundance-weighted trends are negative (NALWG 2019) (NALWG 2018). The dataset for trend analyses included 23 sites across 14 countries/territories. Three periods were used for the trend analysis: long-term (1990-2017), intermediate (1998-2017), and recent (2008-2017) trends. Overall, regional, abundance-weighted trends were negative across the periods and became more negative as the time-series became shorter. At the stock level, the NALWG evaluated the NW Atlantic – Guianas-Trinidad, Florida, Northern Caribbean, and the Western Caribbean. The NW Atlantic – Guianas-Trinidad stock is the largest stock and declined significantly across all periods, which was attributed to an exponential decline in abundance at Awala-Yalimapo, French Guiana as well as declines in Guyana, Suriname, Cayenne, and Matura. Declines in Awala-Yalimapo were attributed, in part, due to beach erosion and a loss of nesting habitat (NALWG 2018). The Florida stock increased significantly over the long-term, but declined from 2008-2017. The Northern Caribbean and Western Caribbean stocks also declined over all three periods. The NALWG report also includes trends at the site-level, which varied depending on the site and time period, but were generally negative especially in the recent time period. The NALWG identified anthropogenic sources (fishery bycatch, vessel strikes), habitat loss, and changes in life history parameters as possible drivers of nesting abundance declines (NALWG 2018). Fisheries bycatch is a well-documented threat to leatherback turtles. The NALWG discussed entanglement in vertical line fisheries off New England and Canada as potentially important mortality sinks. They also noted that vessel strikes result in mortality annually in feeding habitats off New England. Off nesting beaches in Trinidad and the Guianas, net fisheries take leatherbacks in high numbers (~3,000/year; Eckert 2013; NALWG 2018).

Similarly, the leatherback status review concluded that the Northwest Atlantic population segment exhibits decreasing nest trends at nesting aggregations with the greatest indices of nesting female abundance. Significant declines have been observed at nesting beaches with the greatest historical or current nesting female abundance, most notably in Trinidad and Tobago, Suriname, and French Guiana. Though some nesting aggregations (see status review document for information on specific nesting aggregations) indicated increasing trends, most of the largest ones are declining. The declining trend is considered to be representative of the population segment (NMFS and USFWS 2020). The status review found that fisheries bycatch is the primary threat to the Northwest Atlantic population (NMFS and USFWS 2020).

Leatherback sea turtles nest in the southeastern United States. From 1989-2019, leatherback nests at core index beaches in Florida have varied from a minimum of 30 nests in 1990 to a maximum of 657 in 2014 (<https://myfwc.com/research/wildlife/sea-turtles/nesting/beach-survey-totals/>). Leatherback nest numbers reached a peak in 2014 followed by a steep decline (2015-2017) and a promising increase (2018-2021) (<https://myfwc.com/research/wildlife/sea-turtles/nesting/beach-survey-totals/>) (Figure 16). The status review found that the median trend for Florida from 2008-2017 was a decrease of 2.1% annually (NMFS and USFWS 2020). Surveyors counted 435 leatherback nests on the 27 core index beaches in 2021. These counts do not include leatherback nesting at the beginning of the season (before May 15), nor do they represent all the beaches in Florida where leatherbacks nest; however, the index provided by these counts remains a representative reflection of trends. However, while green turtle nest numbers on Florida's index beaches continue to rise, Florida hosts only a few hundred nests annually and leatherbacks can lay as many as 11

clutches during a nesting season. Thus, fluctuations in nest count may be the result of a small change in number of females. More years of standardized nest counts are needed to understand whether the fluctuation is natural or warrants concern.

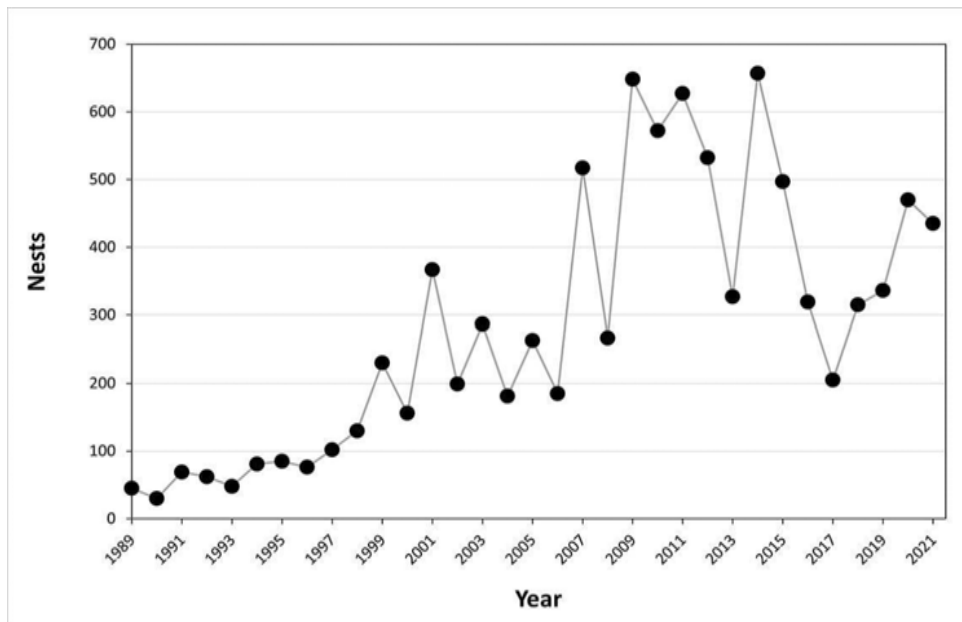

**Figure 16. Number of leatherback sea turtle nests on core index beaches in Florida from 1989-2021**  
<https://myfwc.com/research/wildlife/sea-turtles/nesting/>

For the SW Atlantic population segment, the status review estimates the total index of nesting female abundance at approximately 27 females (NMFS and USFWS 2020). This is similar to the IUCN Red List assessment that estimated 35 mature individuals (male and female) using nesting data since 2010. Nesting has increased since 2010 overall, though the 2014-2017 estimates were lower than the previous three years. The trend is increasing, though variable (NMFS and USFWS 2020). The SE Atlantic population segment has an index of nesting female abundance of 9,198 females and demonstrates a declining nest trend at the largest nesting aggregation (NMFS and USFWS 2020). The SE population segment exhibits a declining nest trend (NMFS and USFWS 2020).

Populations in the Pacific have shown dramatic declines at many nesting sites (Mazaris et al. 2017) (Santidrián-Tomillo et al. 2017; Santidrián Tomillo et al. 2007; Sarti Martinez et al. 2007; Tapilatu et al. 2013). For an IUCN Red List evaluation, datasets for nesting at all index beaches for the West Pacific population were compiled (Tiwari 2013). This assessment estimated the number of total mature individuals (males and females) at Jamursba-Medi and Wermon beaches to be 1,438 turtles (Tiwari 2013). Counts of leatherbacks at nesting beaches in the western Pacific indicate that the subpopulation declined at a rate of almost 6% per year from 1984 to 2011 (Tapilatu et al. 2013). More recently, the leatherback status review estimated the total index of nesting female abundance of the West Pacific population segment at 1,277 females, and the population exhibits low hatchling success (NMFS and USFWS 2020). The total index of nesting female abundance for the East Pacific population segment is 755 nesting females. It has exhibited a decreasing trend since monitoring began with a 97.4% decline since the 1980s or 1990s, depending on nesting beach (Wallace et al. 2013). The low productivity parameters, drastic reductions in nesting female abundance, and current declines in nesting place the population segment at risk (NMFS and USFWS 2020).

Population abundance in the Indian Ocean is difficult to assess due to lack of data and inconsistent reporting. Available data from southern Mozambique show that approximately 10 females nest per year from 1994 to 2004, and about 296 nests per year were counted in South Africa (NMFS and USFWS 2013b). A 5-year status review in 2013 found that, in the southwest Indian Ocean, populations in South Africa are stable (NMFS and USFWS 2013b). More recently, the 2020 status review estimated that the total index of nesting female abundance for the SW Indian population segment is 149 females and that the population is exhibiting a slight decreasing nest trend (NMFS and USFWS 2020). While data on nesting in the NE Indian Ocean populations segment is limited, the population is estimated at 109 females. This population has exhibited a drastic population decline with extirpation of the largest nesting aggregation in Malaysia (NMFS and USFWS 2020).

### **5.6.3 Status**

The leatherback sea turtle is an endangered species whose once large nesting populations have experienced steep declines in recent decades. There has been a global decline overall. For all population segments, including the Northwest Atlantic population, fisheries bycatch is the primary threat to the species (NMFS and USFWS 2020). Leatherback turtle nesting in the Northwest Atlantic showed an overall negative trend through 2017, with the most notable decrease occurring during the most recent time frame of 2008 to 2017 (NALWG 2018). Though some nesting aggregations indicated increasing trends, most of the largest ones are declining. Therefore, the leatherback status review in 2020 concluded that the NW Atlantic population exhibits an overall decreasing trend in annual nesting activity (NMFS and USFWS 2020). Threats to leatherback sea turtles include loss of nesting habitat, fisheries bycatch, vessel strikes, harvest of eggs, and marine debris, among others (NALWG 2018). Because of the threats, once large nesting areas in the Indian and Pacific Oceans are now functionally extinct (Tiwari et al. 2013) and there have been range-wide reductions in population abundance. The species' resilience to additional perturbation both within the NW Atlantic and worldwide is low.

### **5.6.4 Critical Habitat**

Critical habitat has been designated for leatherback sea turtles in the waters adjacent to Sandy Point, St. Croix, U.S. Virgin Islands (44 FR 17710, March 23, 1979) and along the U.S. West Coast (77 FR 4170, January 26, 2012), both of which are outside the action area.

### **5.6.5 Recovery Goals**

There are separate recovery plans for the U.S. Caribbean, Gulf of Mexico, and Atlantic (NMFS and USFWS 1992) and the U.S. Pacific (NMFS and USFWS 1998) populations of leatherback sea turtles. As with other sea turtle species, the recovery plans for leatherbacks include criteria for considering delisting. These criteria relate to increases in the populations, nesting trends, nesting beach and habitat protection, and implementation of priority actions. Criteria for delisting in the recovery plan for the U.S. Caribbean, Gulf of Mexico, and Atlantic are described here.

Delisting criteria:

1. Adult female population increases for 25 years after publication of the recovery plan, as evidenced by a statistically significant trend in nest numbers at Culebra, Puerto Rico; St. Croix, U.S. Virgin Islands; and the east coast of Florida.
2. Nesting habitat encompassing at least 75% of nesting activity in the U.S. Virgin Islands, Puerto Rico, and Florida is in public ownership.

3. All priority-one tasks have been successfully implemented (see the recovery plan for a list of priority 1 tasks).

Major recovery actions in the U.S. Caribbean, Gulf of Mexico, and Atlantic include actions to:

1. Protect and manage terrestrial and marine habitats.
2. Protect and manage the population.
3. Inform and educate the public.
4. Develop and implement international agreements.

The 2013 Five-Year Review (NMFS and USFWS 2013b) concluded that the leatherback turtle should not be delisted or reclassified and notes that the 1991 and 1998 recovery plans are dated and do not address the major, emerging threat of climate change. The following items were the top 5 recovery actions identified to support in the Leatherback Five Year Action Plan:

- Reduce fisheries interactions.
- Improve nesting beach protection and increase reproductive output.
- International cooperation.
- Monitoring and research.
- Public engagement.

### **5.7 Loggerhead Sea Turtle (*Caretta caretta*, Northwest Atlantic Ocean DPS)**

Loggerhead turtles are circumglobal and are found in the temperate and tropical regions of the Pacific, Indian, and Atlantic Oceans. The loggerhead sea turtle is distinguished from other turtles by its reddish-brown carapace, large head and powerful jaws. The species was first listed as threatened under the Endangered Species Act in 1978 (43 FR 32800, July 28, 1978). On September 22, 2011, the NMFS and USFWS designated nine distinct population segments of loggerhead sea turtles, with the Northwest Atlantic Ocean DPS listed as threatened (76 FR 58868). Northwest Atlantic Ocean DPS of loggerhead turtles are found along eastern North America, Central America, and northern South America. The Northwest Atlantic DPS occurs throughout the northwest Atlantic Ocean, Caribbean, and Gulf of Mexico (Figure 17).





**Figure 17. Range of the Northwest Atlantic Ocean DPS loggerhead sea turtles**

We used information available in the 2009 Status Review (Conant et al. 2009), the final listing rule (76 FR 58868, September 22, 2011), the relevant literature, and recent nesting data from the FWRI to summarize the life history, population dynamics and status of the species, as follows.

### 5.7.1 Life History

Loggerhead turtles return to their natal region for mating and nesting. Loggerhead sea turtles reach maturity between 20 and 38 years of age, though the age appears to vary widely among populations (Frazer and Ehrhart 1985; NMFS 2001). The mating season occurs from late March to early June, and eggs are laid throughout the summer months. Females do not nest every year. The average remigration interval is 3.7 years (Tucker 2010). Mean clutch size along the southeastern U.S. coast varies from 100 to 126 eggs (Dodd Jr. 1988). Nesting occurs on beaches, where warm, humid sand temperatures incubate the eggs. There is a 54% emergence success rate (Conant et al. 2009). As with other sea turtles, temperature determines the sex of the turtle during the middle of the incubation period.

Loggerhead sea turtles spend the post-hatchling stage in pelagic waters. The juvenile stage is spent first in the oceanic zone and later in the neritic zone (i.e., coastal waters). Some juveniles may periodically move between the oceanic zone and coastal waters (Bolten and Witherington 2003; Conant et al. 2009; Mansfield 2006;



Morreale and Standora 2005; Witzell 2002). Coastal waters provide important foraging habitat, inter-nesting habitat, and migratory habitat for adult loggerhead turtles. Individuals from multiple nesting colonies can be found on a single feeding ground. In both the oceanic zone and coastal waters, loggerheads are primarily carnivorous, although they do consume some plant matter as well (Conant et al. 2009). Loggerheads have been documented to feed on crustaceans, mollusks, jellyfish and salps, and algae (Bjorndal 1997; Donaton et al. 2019; Seney and Musick 2007). Avens et al. (2015) used 3 approaches to estimate age at maturation. Mean age predictions associated with minimum and mean maturation straight carapace lengths were 22.5-25 and 36-38 years for females and 26-28 and 37-42 years for males. Male and female sea turtles have similar post-maturation longevity, ranging from 4 to 46 (mean 19) years (Avens et al. 2015).

Loggerhead sea turtles are generally thought to circumnavigate the North Atlantic Gyre as pelagic post hatchlings and early juveniles (often occurring in *Sargassum* drift lines or other convergence zones) and may lead a pelagic existence for as long as 7 to 12 years (Bolten et al. 1998). At some point, individuals shift to a different midwater feeding habitat, which in the eastern North Atlantic Ocean is believed to be the waters surrounding the Azore and Madeira Islands. Other oceanic waters include the Grand Banks (Newfoundland, Canada) and the Mediterranean Sea. Juvenile and adult loggerheads most often occur on the continental shelf and shelf edge of the U.S. Atlantic and Gulf coasts, but are also known to inhabit coastal estuaries and bays along both coasts (CETAP 1982; Shoop and Kenney 1992). However, the results of recent studies suggest that not all loggerhead turtles follow this model (Laurent et al. 1998) and some turtles may remain in the pelagic habitat in the North Atlantic longer than hypothesized or move back and forth between pelagic and coastal habitats (Witzell 2002).

Loggerhead hatchlings from the western Atlantic disperse widely, most likely using the Gulf Stream to drift throughout the Atlantic Ocean. Mitochondrial DNA evidence demonstrates that juvenile loggerheads from southern Florida nesting beaches comprise the vast majority (71%-88%) of individuals found in foraging grounds throughout the western and eastern Atlantic: Nicaragua, Panama, Azores and Madeira, Canary Islands and Andalusia, Gulf of Mexico, and Brazil (Masuda 2010). LaCasella et al. (2013) found that loggerheads, primarily juveniles, caught within the Northeast Distant (NED) waters of the North Atlantic mostly originated from nesting populations in the southeast United States and, in particular, Florida. They found that nearly all loggerheads caught in the NED came from the Northwest Atlantic DPS (mean = 99.2%), primarily from the large eastern Florida rookeries. There was little evidence of contributions from the South Atlantic, Northeast Atlantic, or Mediterranean DPSs (LaCasella et al. 2013).

A more recent analysis assessed sea turtles captured in fisheries in the Northwest Atlantic and included samples from 850 (including 24 turtles caught during fisheries research) turtles caught from 2000-2013 in coastal and oceanic habitats (Stewart et al. 2019). The turtles were primarily captured in pelagic longline and bottom otter trawls. Other gears included bottom longline, hook and line, gillnet, dredge, and dip net. Turtles were identified from 19 distinct management units; the western Atlantic nesting populations were the main contributors with little representation from the Northeast Atlantic, Mediterranean, or South Atlantic DPSs (Stewart et al. 2019). There was a significant split in the distribution of small ( $\leq 2$  ft [63 cm] SCL) and large ( $> 2$  ft [63 cm] SCL) loggerheads north and south of Cape Hatteras, North Carolina. North of Cape Hatteras, large turtles came mainly from southeast Florida (44%±15%) and the northern United States management units (33%±16%); small turtles came from central east Florida (64%±14%). South of Cape Hatteras, large turtles came mainly from central east Florida (52%±20%) and southeast Florida (41%±20%); small turtles came from southeast Florida (56%±25%). The authors concluded that bycatch in the western North Atlantic would affect the Northwest Atlantic DPS almost exclusively (Stewart et al. 2019).

### 5.7.2 Population Dynamics

A number of stock assessments and similar reviews (Conant et al. 2009; Ehrhart et al. 2014; FFWCC 2023; NMFS 2009a; TEWG 2009; Wallace et al. 2008) have examined the stock status of loggerheads in the Atlantic Ocean, but none have been able to develop a reliable estimate of absolute population size. As with other species, counts of nests and nesting females are commonly used as an index of abundance and population trends, even though there are doubts about the ability to estimate the overall population size.

The Northwest Atlantic Ocean's loggerhead nesting aggregation is considered the largest in the world (Casale and Tucker 2017). The global abundance of nesting female loggerhead turtles is estimated at 43,320 to 44,560. Using a stage/age demographic model, the adult female population size of the Northwest Atlantic Ocean DPS is estimated at 20,000 to 40,000 females, and 53,000 to 92,000 nests annually (NMFS 2009a). In 2010, there were estimated to be approximately 801,000 loggerhead turtles (greater than 30 cm in size, interquartile range of approximately 521,000–1,111,000) in the northwestern Atlantic continental shelf region based on aerial surveys (NMFS 2011a). More recently, Ceriani and Meylan (2017) reported a 5-year average (2009-2013) of more than 83,717 nests per year in the southeast United States and Mexico (excluding Cancun, Quintana Roo, Mexico).

Based on genetic information, the Northwest Atlantic Ocean DPS of loggerhead turtle is further categorized into 5 recovery units corresponding to nesting beaches: Northern, Peninsular Florida, Dry Tortugas, Northern Gulf of Mexico, and Greater Caribbean (Conant et al. 2009). A more recent analysis using expanded mitochondrial DNA sequences revealed that rookeries from the Gulf and Atlantic coasts of Florida are genetically distinct, and that rookeries from Mexico's Caribbean Sea coast express high haplotype diversity (Shamblin et al. 2014). The recent genetic analyses suggest that the Northwest Atlantic Ocean DPS should be considered as 10 management units: (1) South Carolina and Georgia, (2) central eastern Florida, (3) southeastern Florida, (4) Cay Sal, Bahamas, (5) Dry Tortugas, Florida, (6) southwestern Cuba, (7) Quintana Roo, Mexico, (8) southwestern Florida, (9) central western Florida, and (10) northwestern Florida (Shamblin et al. 2012).

The Northwest Atlantic Ocean's loggerhead nesting aggregation is considered the largest in the world (Casale and Tucker 2017). Using data from 2004-2008, the adult female population size of the DPS was estimated at 20,000 to 40,000 females (NMFS 2009a). More recently, Ceriani and Meylan (2017) reported a 5-year average (2009-2013) of more than 83,717 nests per year in the southeast United States and Mexico (excluding Cancun (Quintana Roo, Mexico). These estimates included sites without long-term ( $\geq 10$  years) datasets. When they used data from 86 index sites (representing 63.4% of the estimated nests for the whole DPS with long-term datasets, they reported 53,043 nests per year. Trends at the different index nesting beaches ranged from negative to positive. In a trend analysis of the 86 index sites, the overall trend for the Northwest Atlantic DPS was positive (+2%) (Ceriani and Meylan 2017). Uncertainties in this analysis include, among others, using nesting females as proxies for overall population abundance and trends, demographic parameters, monitoring methodologies, and evaluation methods involving simple comparisons of early and later 5-year average annual nest counts. However, the authors concluded that the subpopulation is well monitored and the data evaluated represents 63.4 % of the total estimated annual nests of the subpopulation and, therefore, are representative of the overall trend (Ceriani and Meylan 2017).

About 80% of loggerhead nesting in the southeast United States occurs in six Florida counties (NMFS and USFWS 2008). The Peninsula Florida Recovery Unit and the Northern Recovery Unit represent approximately 87% and 10%, respectively of all nesting effort in the Northwest Atlantic DPS (Ceriani and Meylan 2017) (NMFS and USFWS 2008). As described above, FWRI's INBS collects standardized nesting data. The index nest counts for loggerheads represent approximately 53% of known nesting in Florida. There have been three distinct intervals observed: increasing (1989-1998), decreasing (1998-2007), and increasing (2007-2021). At core index beaches in Florida, nesting totaled a minimum of 28,876 nests in 2007 and a maximum of 65,807

nests in 2016 (<https://myfwc.com/research/wildlife/sea-turtles/nesting/beach-survey-totals/>). In 2019, more than 53,000 nests were documented. In 2020, loggerhead turtles had another successful nesting season with more than 49,100 nests documented. The nest counts in Figure 18 represent peninsular Florida and do not include an additional set of beaches in the Florida Panhandle and southwest coast that were added to the program in 1997. Nest counts at these Florida Panhandle index beaches have an upward trend since 2010 (Figure 19).

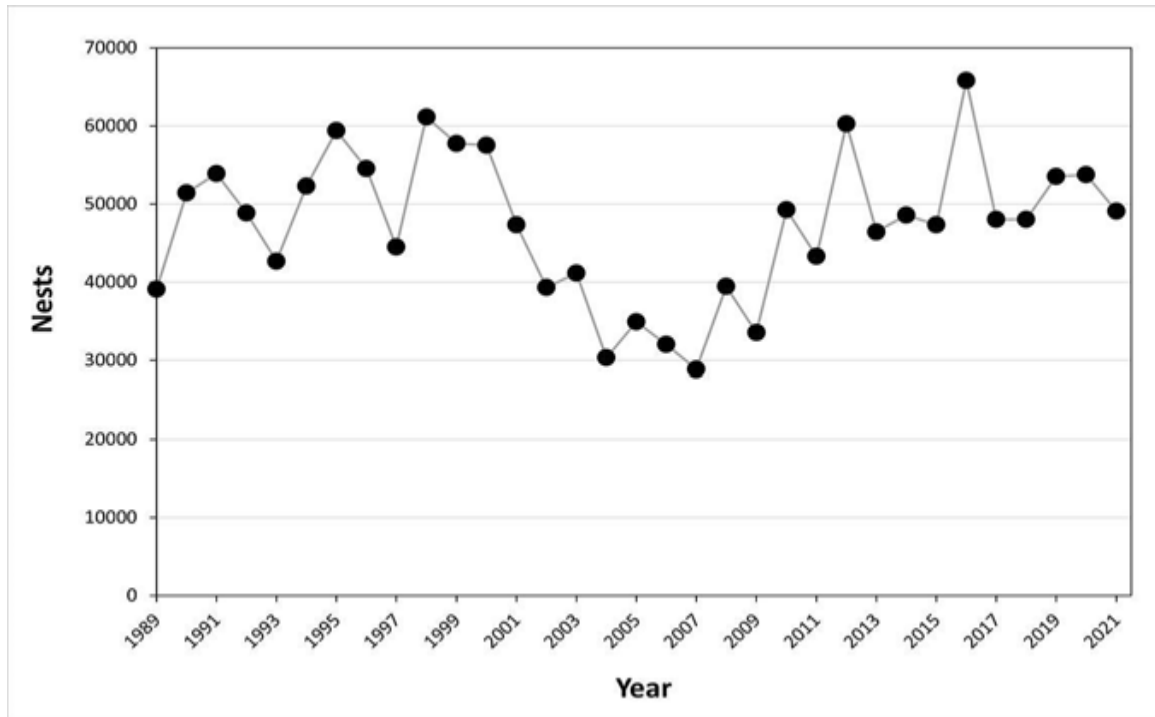
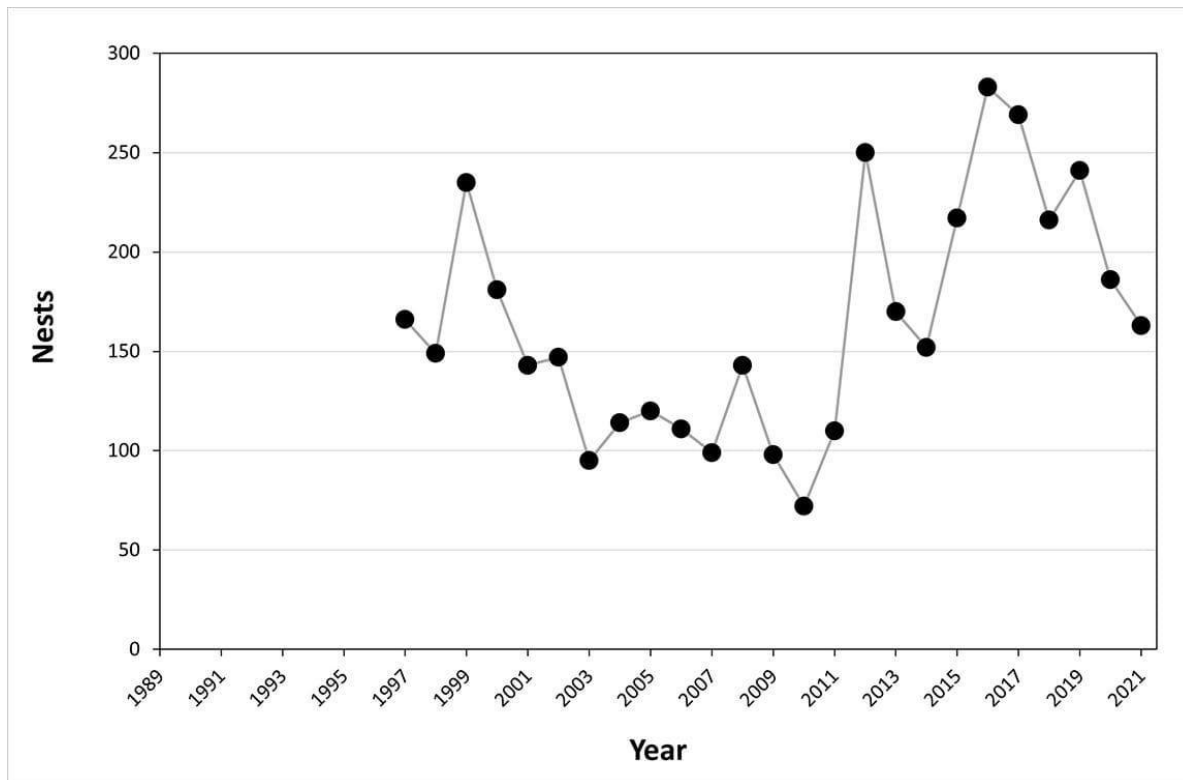

Figure 18. Annual nest counts of loggerhead sea turtles on Florida core index beaches in peninsular Florida, 1989-2021 (<https://myfwc.com/research/wildlife/sea-turtles/nesting/beach-survey-totals/>)



**Figure 19. Annual nest counts of loggerhead sea turtles on index beaches in the Florida Panhandle, 1997-2021**  
[\(https://myfwc.com/research/wildlife/sea-turtles/nesting/beach-survey-totals/\)](https://myfwc.com/research/wildlife/sea-turtles/nesting/beach-survey-totals/)

The annual nest counts on Florida’s index beaches fluctuate widely, and we do not fully understand what drives these fluctuations. In assessing the population, Ceriani and Meylan (2017) and Bolten et al. (2019) looked at trends by recovery unit. Trends by recovery unit were variable.

The Peninsular Florida Recovery Unit extends from the Georgia-Florida border south and then north (excluding the islands west of Key West, Florida) through Pinellas County on the west coast of Florida. The Peninsular Florida Recovery Unit constitutes the large majority of nesting effort in the Northwest Atlantic Ocean DPS. Bolten et al. (2019) reported annual nest counts from 1989 to 2018 ranged from a low of 28,876 in 2007 to a high of 65,807 in 1998. More recently (2008-2018), counts have ranged from 33,532 in 2009 to 65,807 in 2016 (Bolten et al. 2019). From 1989 to 2018, this unit averaged an estimated 70,935 nests annually based on the Florida Fish and Wildlife Conservation Commission Statewide Nesting Beach Survey, and 47,433 nests annually based on the Florida Index Nesting Beach Survey (Ceriani et al. 2019). Nest counts taken at index beaches in Peninsular Florida showed a significant decline in loggerhead nesting from 1989 to 2007, most likely attributed to mortality of oceanic-stage loggerheads caused by fisheries bycatch (Witherington et al. 2009). Trend analyses have been completed for various periods. From 2009 through 2013, a 2% decrease for this recovery unit was reported (Ceriani and Meylan 2017). Using a longer time series from 1989-2018, there was no significant change in the number of annual nests (Bolten et al. 2019). It is important to recognize that an increase in the number of nests has been observed since 2007. The recovery team cautions that using short-term trends in nesting abundance can be misleading and trends should be considered in the context of 1 generation (50 years for loggerheads; Bolten et al. 2019).

The Northern Recovery Unit, ranging from the Florida-Georgia border through southern Virginia, is the second largest nesting aggregation in the Northwest Atlantic Ocean DPS. Bolten et al. (2019) reported annual nest

totals for this recovery unit from 1983 to 2019 have ranged from a low of 520 in 2004 to a high of 5,555 in 2019. From 2008 to 2019, counts have ranged from 1,289 nests in 2014 to 5,555 nests in 2019 (Bolten et al. 2019). Nest counts at loggerhead nesting beaches in North Carolina, South Carolina, and Georgia declined at 1.9% annually from 1983 to 2005 (NMFS and USFWS 2008). Recently, the trend has been increasing. Ceriani and Meylan (2017) reported a 35% increase for this recovery unit from 2009 through 2013. A longer-term trend analysis based on data from 1983 to 2019 indicates that the annual rate of increase is 1.3% (Bolten et al. 2019).

The Dry Tortugas Recovery Unit includes all islands west of Key West, Florida. A census on Key West from 1995 to 2004 (excluding 2002) estimated a mean of 246 nests per year, or about 60 nesting females (NMFS and USFWS 2008). No trend analysis is available because there was not an adequate time series to evaluate the Dry Tortugas recovery unit (Ceriani et al. 2019; Ceriani and Meylan 2017), which accounts for less than 1% of the Northwest Atlantic DPS (Ceriani and Meylan 2017).

The Northern Gulf of Mexico Recovery Unit is defined as loggerheads originating from beaches in Franklin County on the northwest Gulf coast of Florida through Texas. From 1995 to 2007, there were an average of 906 nests per year on approximately 300 km of beach in Alabama and Florida, which equates to about 221 females nesting per year (NMFS and USFWS 2008). Annual nest totals for this recovery unit from 1997-2018 have ranged from a low of 72 in 2010 to a high of 283 in 2016 (Bolten et al. 2019). Evaluation of long-term nesting trends for the Northern Gulf of Mexico Recovery Unit is difficult because of changed and expanded beach coverage. However, there are now over 20 years of Florida index nesting beach survey data. A number of trend analyses have been conducted. From 1995 to 2005, the recovery unit exhibited a significant declining trend (Conant et al. 2009; NMFS and USFWS 2008). Nest numbers have increased in recent years (Bolten et al. 2019; see <https://myfwc.com/research/wildlife/sea-turtles/nesting/beach-survey-totals/>). In the 2009-2013 trend analysis by Ceriani and Meylan (2017), a 1% decrease for this recovery unit was reported, likely due to diminished nesting on beaches in Alabama, Mississippi, Louisiana, and Texas. A longer-term analysis from 1997-2018 found that there has been a non-significant increase of 1.7% (Bolten et al. 2019).

The Greater Caribbean Recovery Unit encompasses nesting subpopulations in Mexico to French Guiana, the Bahamas, and the lesser and Greater Antilles. The majority of nesting for this recovery unit occurs on the Yucatán Peninsula, in Quintana Roo, Mexico, with 903 to 2,331 nests annually (Zurita et al. 2003). Other significant nesting sites are found throughout the Caribbean, including Cuba, with approximately 250 to 300 nests annually (Ehrhart et al. 2003), and over 100 nests annually in Cay Sal in the Bahamas (NMFS and USFWS 2008). In the trend analysis by Ceriani and Meylan (2017), a 53% increase for this Recovery Unit was reported from 2009 through 2013.

### 5.7.3 Status

Due to declines in nest counts at index beaches in the U.S. and Mexico, and continued mortality of juveniles and adults from fishery bycatch, the Northwest Atlantic Ocean DPS of loggerhead turtle is at risk and likely to decline in the foreseeable future (Conant et al. 2009). Fisheries bycatch is the highest threat to the Northwest Atlantic DPS of loggerhead sea turtles (Conant et al. 2009). Other threats include boat strikes, marine debris, coastal development, habitat loss, contaminants, disease, and climate change. Nesting trends for each of the loggerhead sea turtle recovery units in the Northwest Atlantic Ocean DPS are variable. Overall, short-term trends have shown increases; however, the DPS is considered stable over the long-term, as reported in the NMFS Fiscal Year 2019-2020 ESA Report to Congress (NMFS 2022e).

### 5.7.4 Critical Habitat

On July 10, 2014, NMFS and the U.S. Fish and Wildlife Service designated critical habitat for the Northwest Atlantic Ocean DPS of loggerhead turtles along the U.S. Atlantic and Gulf of Mexico coasts from North Carolina to Mississippi (79 FR 39856; Figure 20). Critical habitat for the Northwest Atlantic DPS of the loggerhead sea turtle includes 38 occupied marine areas within the range of the Northwest Atlantic DPS that contain at least one, or a combination of, the following habitat types: nearshore reproductive habitat, winter area, breeding area, constricted migratory corridor, and *Sargassum* habitat.

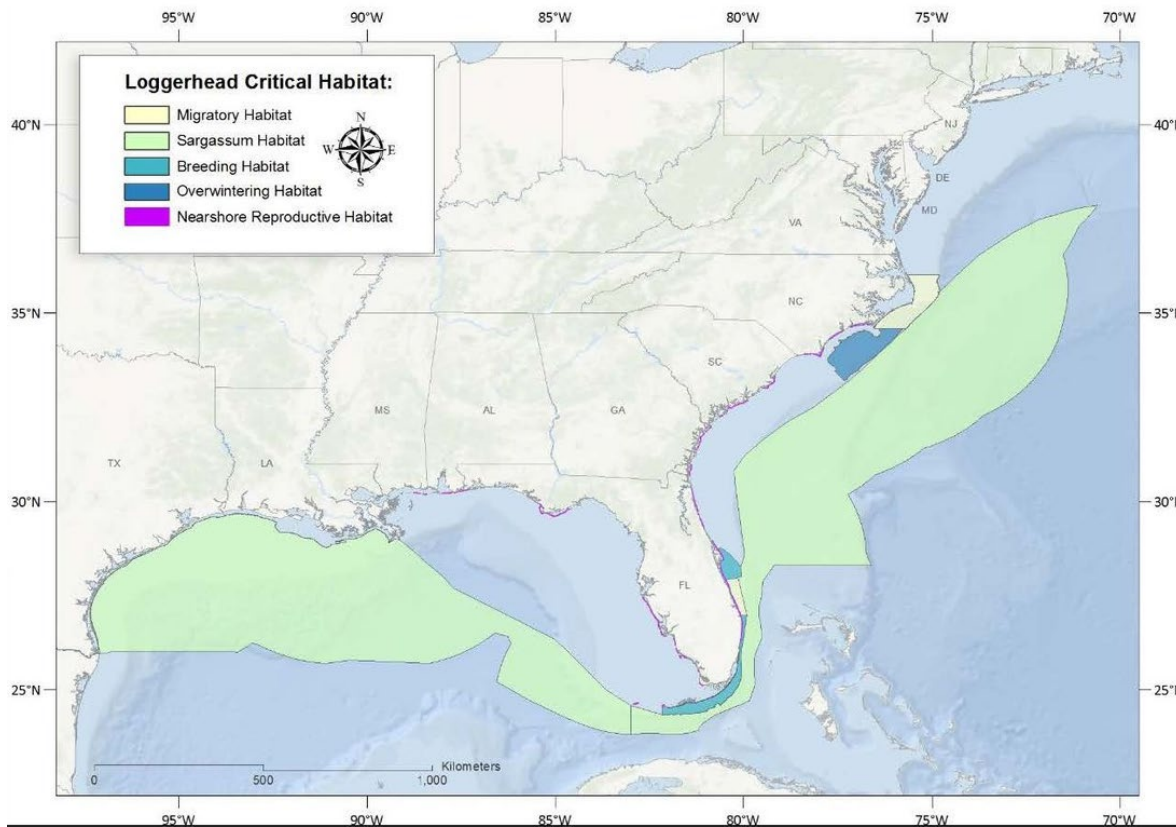

**Figure 20. Map identifying designated critical habitat for the Northwest Atlantic Ocean DPS of loggerhead turtle**

NMFS identified physical and biological features (PBFs) essential for the conservation of loggerhead sea turtles for each of these habitat types as follows:

- **Nearshore Reproductive Critical Habitat:** 1) Nearshore waters with direct proximity to nesting beaches that support critical aggregations of nesting turtles (e.g., highest density nesting beaches) to 1.6 km (1 mile) offshore, 2) waters sufficiently free of obstructions or artificial lighting to allow transit through the surf zone and outward toward open water, and 3) waters with minimal manmade structures that could promote predators (i.e., nearshore predator concentration caused by submerged and emergent offshore structures), disrupt wave patterns necessary for orientation, and/or create excessive longshore currents.
- **Winter Critical Habitat:** 1) Water temperatures above 10° C during the colder months of November through April, 2) continental shelf waters in proximity to the western boundary of the Gulf Stream, and 3) water depths between 20 and 100 m.

- Constricted Migratory Critical Habitat: 1) Constricted continental shelf area relative to nearby continental shelf waters that concentrate migratory pathways, and 2) passage conditions to allow for migration to and from nesting, breeding, and/or foraging areas.
- *Sargassum* Critical Habitat: 1) Convergence zones, surface-water downwelling areas, and other locations where there are concentrated components of the *Sargassum* community in water temperatures suitable for the optimal growth of *Sargassum* and inhabitation of loggerheads, 2) *Sargassum* in concentrations that support adequate prey abundance and cover, 3) available prey and other material associated with *Sargassum* habitat such as, but not limited to, plants and cyanobacteria and animals endemic to the *Sargassum* community such as hydroids and copepods, and 4) sufficient water depth and proximity to available currents to ensure offshore transport, and foraging and cover requirements by *Sargassum* for post-hatchling loggerheads, i.e., > 10 m depth to ensure not in surf zone.

### 5.7.5 Recovery Goals

The recovery goal for the Northwest Atlantic loggerhead is to ensure that each recovery unit meets its recovery criteria, alleviating threats to the species so that protection under the ESA is not needed. The recovery criteria relate to the number of nests and nesting females, trends in abundance on the foraging grounds, and trends in neritic strandings relative to in-water abundance. The 2008 Final Recovery Plan for the Northwest Atlantic Population of Loggerheads includes the complete downlisting/delisting criteria (NMFS and USFWS 2008). The recovery objectives to meet these goals include:

- Ensure that the number of nests in each recovery unit is increasing and that this increase corresponds to an increase in the number of nesting females.
- Ensure the in-water abundance of juveniles in both neritic and oceanic habitats is increasing and is increasing at a greater rate than strandings of similar age classes.
- Manage sufficient nesting beach habitat to ensure successfully nesting.
- Manage sufficient feeding, migratory, and interesting marine habitats to ensure successful growth and reproduction.
- Eliminate legal harvest.
- Implement scientifically based nest management plans.
- Minimize nest predation.
- Recognize and respond to mass/unusual mortality or disease event appropriately.
- Develop and implement local, state, Federal, and international legislation to ensure long-term protection of loggerhead sea turtles and their terrestrial and marine habitats.
- Minimize bycatch in domestic and international commercial and artisanal fisheries.
- Minimize trophic changes from fishery harvest and habitat alteration.
- Minimize marine debris ingestions and entanglement.
- Minimize vessel strike mortality.

### 5.8 Kemp's Ridley Sea Turtle (*Lepidochelys kempii*)

The Kemp's ridley sea turtle was first listed under the Endangered Species Conservation Act, a precursor to the ESA, in 1970 (35 FR 18319, December 2, 1970). The species has been listed as endangered under the ESA since 1973. Internationally, the Kemp's ridley is considered the most endangered sea turtle (Groombridge 1982; TEWG 2000; Zwinenberg 1977).

The range of Kemp's ridley sea turtles extends from the Gulf of Mexico to the Atlantic coast (Figure 21). They have occasionally been found in the Mediterranean Sea, which may be due to migration expansion or increased



hatchling production (Tomas and Raga 2008). They are the smallest of all sea turtle species, with a nearly circular top shell and a pale yellowish bottom shell.

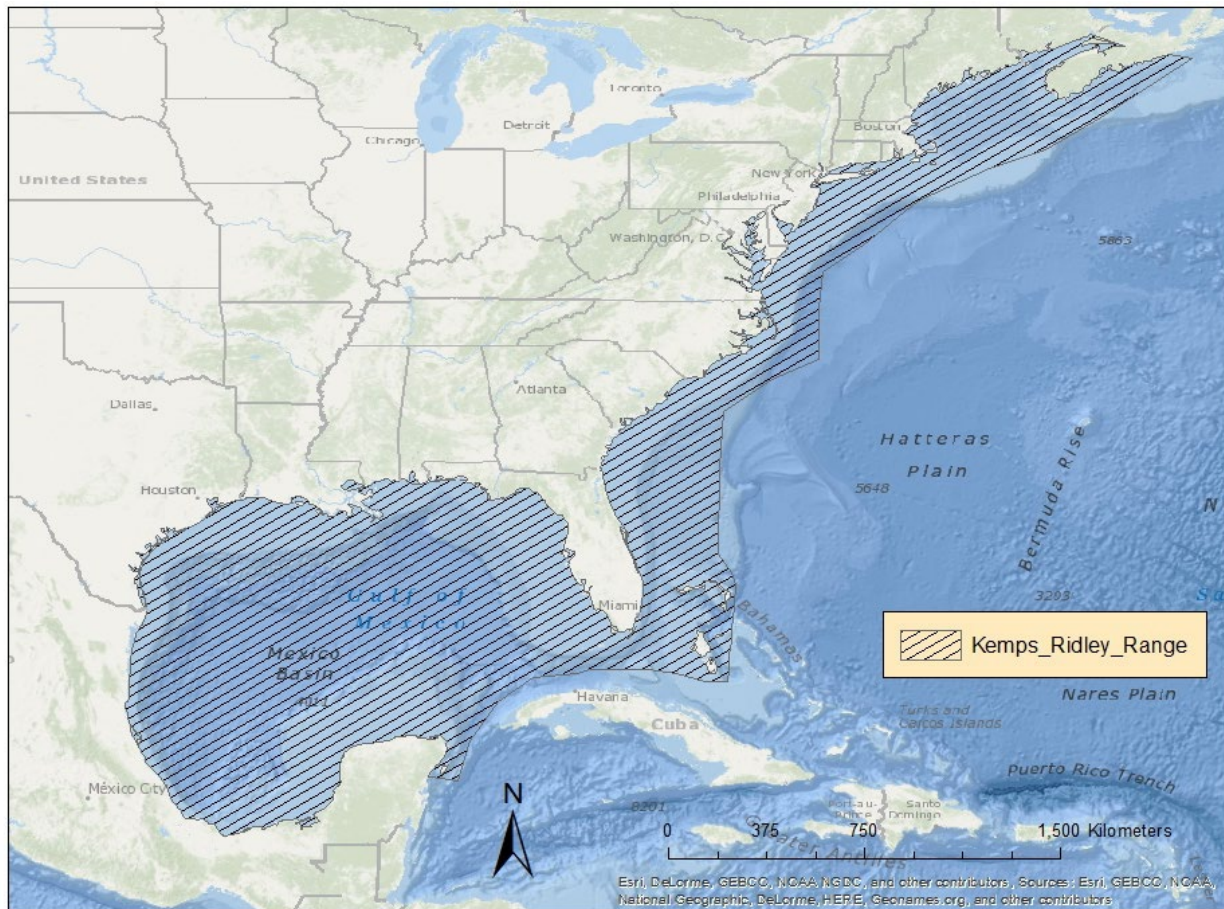

**Figure 21. Kemp's ridley sea turtle geographic range**

We used information available in the revised recovery plan (NMFS et al. 2011), the five-year review (NMFS and USFWS 2015b), and the scientific literature to summarize the life history, population dynamics, and status of the species, as follows.

### 5.8.1 Life History

Kemp's ridley nesting is essentially limited to the western Gulf of Mexico. Approximately 97% of the global population's nesting activity occurs on a 90-mile (146-km) stretch of beach that includes Rancho Nuevo in Mexico (Wibbels and Bevan 2019). In the United States, nesting occurs primarily in Texas and occasionally in Florida, Alabama, Georgia, South Carolina, and North Carolina (NMFS and USFWS 2015b). Nesting occurs from April to July in large arribadas (synchronized large-scale nesting), primarily at Rancho Nuevo, Mexico (Wibbels and Bevan 2019). Females mature at 12 years of age. The average remigration interval is 2 years, although intervals of 1 and 3 years are not uncommon (NMFS et al. 2011; TEWG 1998; TEWG 2000). Females lay an average of 2.5 clutches per season (NMFS et al. 2011). The annual average clutch size is 95 to 112 eggs per nest (NMFS and USFWS 2015b). The nesting location may be particularly important because hatchlings can more easily migrate to foraging grounds in deeper oceanic waters, where they remain for approximately 2 years before returning to nearshore coastal habitats (Epperly et al. 2013; NMFS and USFWS 2015b; Snover et al. 2007).



Modeling indicates that oceanic-stage Kemp's ridley turtles are likely distributed throughout the Gulf of Mexico into the northwestern Atlantic (Putman et al. 2013). Kemp's ridley nearing the age when recruitment to nearshore waters occurs are more likely to be distributed in the northern Gulf of Mexico, eastern Gulf of Mexico, and the western Atlantic (Putman et al. 2013). Juvenile Kemp's ridley turtles use these nearshore coastal habitats from April through November, but move towards more suitable overwintering habitat in deeper offshore waters (or more southern waters along the Atlantic coast) as water temperature drops. Adult habitat largely consists of sandy and muddy areas in shallow, nearshore waters less than 37 m deep, although they can also be found in deeper offshore waters. As adults, Kemp's ridley turtles forage on swimming crabs, fish, jellyfish, mollusks, and tunicates (NMFS et al. 2011).

Several studies, including those of captive turtles, recaptured turtles of known age, mark-recapture data, and skeletochronology, have estimated the average age at sexual maturity for Kemp's ridleys between 5 to 12 years (captive only; Bjorndal et al. 2014), 10 to 16 years (Chaloupka and Zug 1997; Schmid and Witzell 1997; Zug et al. 1997), 9.9 to 16.7 years (Snover et al. 2007), 10 and 18 years (Shaver and Wibbels 2007), 6.8 to 21.8 years (mean 12.9 years; Avens et al. 2017).

During spring and summer, juvenile Kemp's ridleys generally occur in the shallow coastal waters of the northern Gulf of Mexico from south Texas to north Florida and along the U.S. Atlantic coast from southern Florida to the Mid-Atlantic and New England. In the fall, most Kemp's ridleys migrate to deeper or more southern, warmer waters and remain there through the winter. As adults, many turtles remain in the Gulf of Mexico, with only occasional occurrence in the Atlantic Ocean (NMFS et al. 2011). Adult habitat largely consists of sandy and muddy areas in shallow, nearshore waters less than 120 ft (37 m) deep (Seney and Landry 2008; Shaver and Rubio 2008; Shaver et al. 2005), although they can also be found in deeper offshore waters. As larger juveniles and adults, Kemp's ridleys forage on swimming crabs, fish, mollusks, and tunicates (NMFS et al. 2011).

### **5.8.2 Population Dynamics**

Of the sea turtle species in the world, the Kemp's ridley has declined to the lowest population level. Nesting aggregations at a single location (Rancho Nuevo, Mexico) were estimated at 40,000 females in 1947. By the mid-1980s, the population had declined to an estimated 300 nesting females. From 1980 through 2003, the number of nests at 3 primary nesting beaches (Rancho Nuevo, Tepehuajes, and Playa Dos) increased 15% annually (Heppell et al. 2005). However, due to recent declines in nest counts, decreased survival of immature and adult sea turtles, and updated population modeling, this rate is not expected to continue and the overall trend is unclear (Caillouet et al. 2018; NMFS and USFWS 2015b). In 2019, there were 11,090 nests, a 37.61% decrease from 2018, and a 54.89% decrease from 2017, which had the highest number (24,587) of nests (Figure 22; unpublished data). The reason for this recent decline is uncertain. In 2021, 198 Kemp's ridley nests were found in Texas – the largest number recorded in Texas since 1978 was in 2017, when 353 nests were documented.

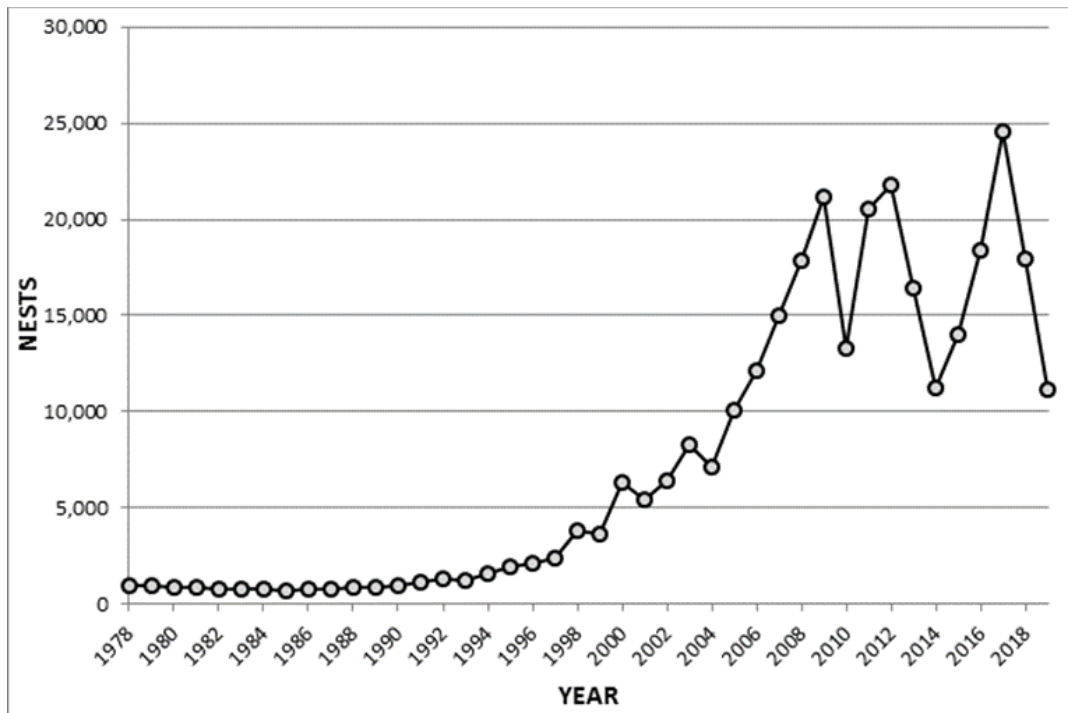

Figure 22. Kemp's ridley nest totals from Mexican beaches (Gladys Porter Zoo nesting database 2019)

Using the standard IUCN protocol for sea turtle assessments, the number of mature individuals was recently estimated at 22,341 (Wibbels and Bevan 2019). The calculation took into account the average annual nests from 2016-2018 (21,156), a clutch frequency of 2.5 per year, a remigration interval of 2 years, and a sex ratio of 3.17 females: 1 male. Based on the data in their analysis, the assessment concluded the current population trend is unknown (Wibbels and Bevan 2019). Genetic variability in Kemp's ridley turtles is considered to be high, as measured by nuclear DNA analyses (i.e., microsatellites; NMFS et al. 2011). If this holds true, rapid increases in population over 1 or 2 generations would likely prevent any negative consequences in the genetic variability of the species (NMFS et al. 2011). Additional analysis of samples taken from Kemp's ridley turtles at Padre Island, Texas, showed 6 distinct haplotypes, with 1 found at both Padre Island and Rancho Nuevo (Dutton et al. 2006).

### 5.8.3 Status

The Kemp's ridley was listed as endangered in response to a severe population decline, primarily the result of egg collection. In 1973, legal ordinances in Mexico prohibited the harvest of sea turtles from May to August, and in 1990, the harvest of all sea turtles was prohibited by presidential decree. In 2002, Rancho Nuevo was declared a sanctuary. Nesting beaches in Texas have been re-established. Fishery interactions are the main threat to the species. Other threats include habitat destruction, oil spills, dredging, disease, cold stunning, and climate change. The current population trend is uncertain. While the population has increased, recent nesting numbers have been variable. In addition, the species' limited range and low global abundance make it vulnerable to new sources of mortality as well as demographic and environmental randomness, all of which are often difficult to predict with any certainty. Therefore, its resilience to future perturbation affecting survival and nesting success is low.

#### 5.8.4 Critical Habitat

Critical habitat has not been designated for Kemp's ridley sea turtles.

#### 5.8.5 Recovery Goals

In response to the current threats facing the species, NMFS developed goals to recover Kemp's ridley turtle populations. These threats will be discussed in further detail in the environmental baseline section of this Opinion. See the 2011 Final Bi-National (U.S. and Mexico) Revised Recovery Plan for Kemp's ridley turtles for complete downlisting/delisting criteria for each of their respective recovery goals (NMFS et al. 2011). The following items were identified as priorities to recover Kemp's ridley turtles:

- Protect and manage nesting and marine habitats.
- Protect and manage populations on the nesting beaches and in the marine environment.
- Maintain a stranding network.
- Manage captive stocks.
- Sustain education and partnership programs.
- Maintain, promote awareness of and expand U.S. and Mexican laws.
- Implement international agreements.
- Enforce laws.

As with other recovery plans, the goal of the 2011 Kemp's ridley recovery plan (NMFS et al. 2011) is to conserve and protect the species so that the listing is no longer necessary. The recovery criteria relate to the number of nesting females, hatchling recruitment, habitat protection, social and/or economic initiatives compatible with conservation, reduction of predation, TED or other protective measures in trawl gear, and improved information available to ensure recovery. In 2015, the bi-national recovery team published a number of recommendations including 4 critical actions (NMFS and USFWS 2015b). These include: (a) continue funding by the major funding institutions at a level of support needed to run the successful turtle camps in the State of Tamaulipas, Mexico, in order to continue the high level of hatchling production and nesting female protection; (b) increase turtle excluder device (TED) compliance in U.S. and MX shrimp fisheries; 3 (c) require TEDs in U.S. skimmer trawl fisheries and other trawl fisheries in coastal waters where fishing overlaps with the distribution of Kemp's ridleys; (d) assess bycatch in gillnets in the Northern Gulf of Mexico and State of Tamaulipas, Mexico, to determine whether modifications to gear or fishing practices are needed. The most recent Five-Year Review was completed in 2015 (NMFS and USFWS 2015b) with a recommendation that the status of Kemp's ridley sea turtles should remain as endangered. In the Plan, the Services recommend that efforts continue towards achieving the major recovery actions in the 2015 plan with a priority for actions to address recent declines in the annual number of nests.

The most recent Five-Year Review was completed in 2015 (NMFS and USFWS 2015b) with a recommendation that the status of Kemp's ridley sea turtles should remain as endangered. In the Plan, the Services recommend that efforts continue towards achieving the major recovery actions in the 2015 plan with a priority for actions to address recent declines in the annual number of nests.

#### 5.9 Atlantic Sturgeon (*Acipenser oxyrinchus oxyrinchus*)

An estuarine-dependent anadromous species, Atlantic sturgeon occupy ocean and estuarine waters, including sounds, bays, and tidal-affected rivers from Hamilton Inlet, Labrador, Canada, to Cape Canaveral, Florida (ASSRT 2007; Figure 23). On February 6, 2012, NMFS listed 5 DPSs of Atlantic sturgeon under the ESA: Gulf of Maine (GOM), New York Bight (NYB), Chesapeake Bay (CB), Carolina, and South Atlantic (77 FR 5880

and 77 FR 5914). The Gulf of Maine DPS is listed as threatened, and the New York Bight, Chesapeake Bay, Carolina, and South Atlantic DPSs are listed as endangered.

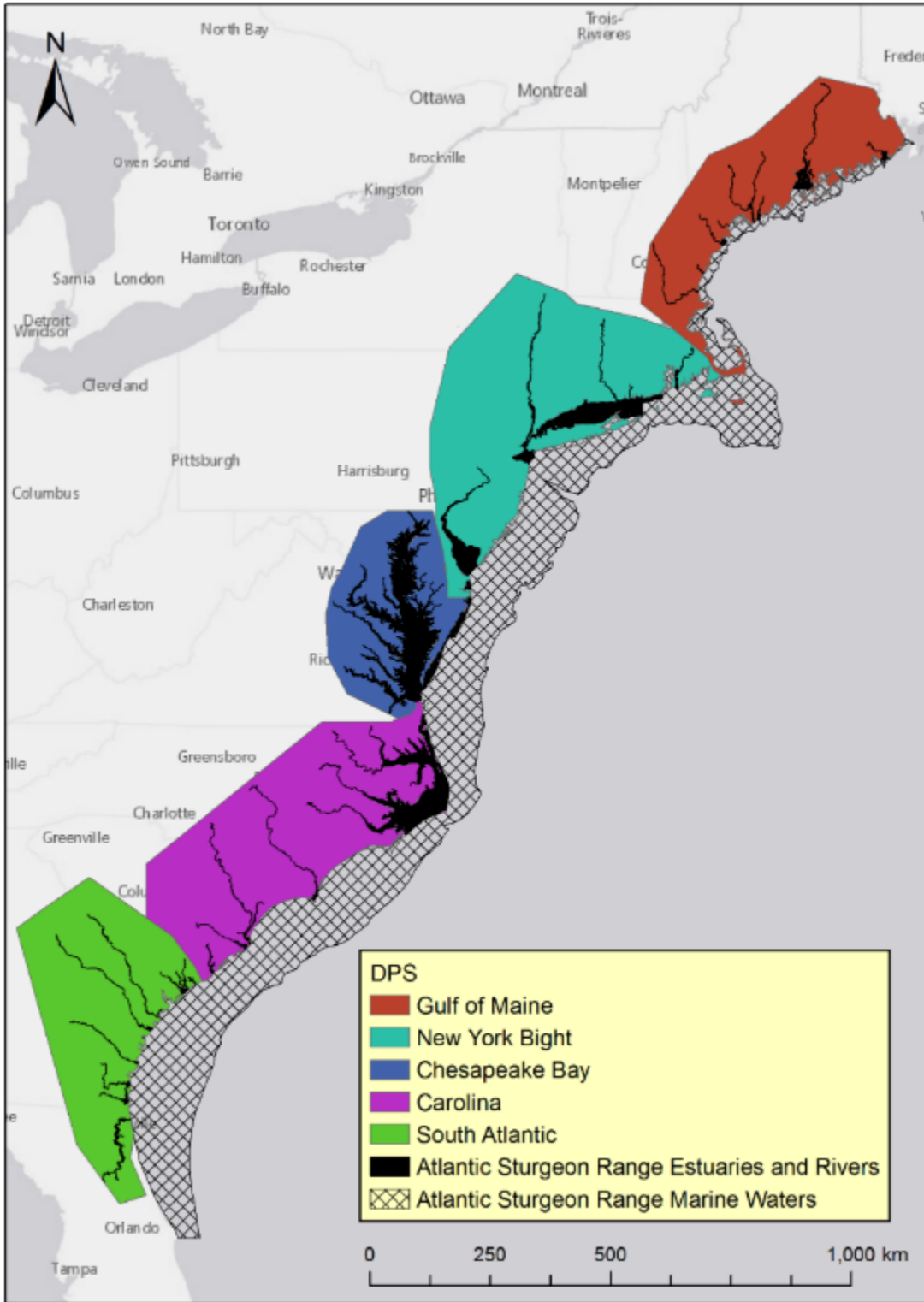

Figure 23. U.S. range of Atlantic sturgeon DPSs

Information available from the 2007 Atlantic sturgeon status review (ASSRT 2007), 2017 ASMFC benchmark stock assessment (ASMFC 2017), final listing rules (77 FR 5880 and 77 FR 5914; February 6, 2012), material supporting the designation of Atlantic sturgeon critical habitat (NMFS 2017a), and Five-Year Reviews completed for the Gulf of Maine, New York Bight, and Chesapeake Bay DPSs (NMFS 2022a; NMFS 2022b; NMFS 2022c) were used to summarize the life history, population dynamics, and status of the species.

### 5.9.1 Life History

Atlantic sturgeon are a late maturing, anadromous species (ASSRT 2007; Balazik et al. 2010; Dadswell 2006; Hilton et al. 2016). Atlantic sturgeon have been aged to 60 years, but this should be taken as an approximation because the age validation studies conducted to date show ages cannot be reliably estimated after 15-20 years as annuli become harder to read accurately (Stevenson and Secor 1999). Sexual maturity is reached between the ages of 5 to 34 years. Sturgeon originating from rivers in lower latitudes (e.g., South Carolina rivers) mature faster than those originating from rivers located in higher latitudes (e.g., Saint Lawrence River) (NMFS 2017a).

Fecundity of Atlantic sturgeon is correlated with age and body size, ranging from approximately 400,000 to 2 million eggs (Dadswell 2006; Mitchell et al. 2020; Van Eenennaam and Doroshov 1998). The average age at which 50% of maximum lifetime egg production is achieved is estimated to be 29 years, approximately 3 to 10 times longer than for other bony fish species examined (Boreman 1997). Spawning intervals range from 1 to 5 years for male Atlantic sturgeon (Collins et al. 2000a; Smith 1985) and 2 to 5 years for females (Breece et al. 2021; Hager et al. 2020; Schueller and Peterson 2010; Secor et al. 2000). For Atlantic sturgeon from the York River, Virginia, Hager et al. (2020) found that both males and females return to spawn at more frequent intervals than has been reported in the literature (males once every 1.13 years and females once every 2.19 years, on average). Similarly, Breece et al. (2021) reported mean spawning intervals for Hudson River Atlantic sturgeon of 1.66 years for females and 1.28 years for males, Breece et al. (2021) with many fish spawning in consecutive years.

Atlantic sturgeon spawn in freshwater (ASSRT 2007) at sites with flowing water and hard bottom substrate (Bain et al. 2000; Balazik et al. 2012b; Gilbert 1989; Greene et al. 2009) (Hatin et al. 2002; Mohler 2003; Smith and Clugston 1997; Vladykov and Greeley 1963). Water depths of spawning sites are highly variable, but may be up to 88.5 ft (27 m) (Bain et al. 2000; Crance 1987; Leland 1968; Scott and Crossman 1973). Based on tagging records, Atlantic sturgeon return to their natal rivers to spawn (ASSRT 2007), with spawning intervals ranging from one to five years in males (Caron et al. 2002; Collins et al. 2000b; Smith 1985) and two to five years in females (Stevenson and Secor 1999; Van Eenennaam et al. 1996; Vladykov and Greeley 1963). Some Atlantic sturgeon river populations may have up to two spawning seasons comprised of different spawning adults (Balazik and Musick 2015; Collins et al. 2000b), although the majority likely have just one, either in the spring or fall.<sup>15</sup> There is evidence of spring and fall spawning for the South Atlantic DPS (77 FR 5914, February 6, 2012, (Collins et al. 2000b; NMFS 1998) (Collins et al. 2000b), spring spawning for the Gulf of Maine and New York Bight DPSs (NMFS 2017a), and fall spawning for the Chesapeake and Carolina DPSs (Balazik et al. 2012a; Smith et al. 1984). While spawning has not been confirmed in the James River (Chesapeake Bay DPS), telemetry and empirical data suggest that there may be two potential spawning runs: a spring run from late March to early May and a fall run around September after an extended staging period in the lower river (Balazik et al. 2012a; Balazik and Musick 2015).

---

<sup>15</sup> Although referred to as spring spawning and fall spawning, the actual time of Atlantic sturgeon spawning may not occur during the astronomical spring or fall season Balazik, M. T., and J. A. Musick. 2015. Dual annual spawning races in Atlantic sturgeon. PLOS ONE 10(5):e0128234.

Following spawning, males move downriver to the lower estuary and remain there until outmigration in the fall (Bain et al. 2000; Bain 1997; Balazik et al. 2012a; Breece et al. 2013; Dovel and Berggren 1983; Ingram et al. 2019a; Smith 1985). Females move downriver and may leave the estuary and travel to other coastal estuaries until outmigration to marine waters in the fall (Bain et al. 2000; Bain 1997; Balazik et al. 2012a; Breece et al. 2013; Dovel and Berggren 1983; Greene et al. 2009; NMFS 2017a; Smith 1985). Atlantic sturgeon deposit eggs on hard bottom substrate. They hatch into the yolk sac larval stage approximately 94 to 140 hours after deposition (Mohler 2003; Murawski and Pacheco 1977; Smith et al. 1980; Van Den Avyle 1984; Vladykov and Greeley 1963). Once the yolk sac is absorbed (eight to twelve days post-hatching), sturgeon are larvae. Shortly after, they become young-of-the-year and then juveniles. The juvenile stage can last months to years in the brackish waters of the natal estuary (ASSRT 2007; Calvo et al. 2010; Collins et al. 2000a; Dadswell 2006; Dovel and Berggren 1983; Greene et al. 2009; Hatin et al. 2007; Holland and Yelverton 1973; Kynard and Horgan 2002; Mohler 2003; Schueller and Peterson 2010; Secor et al. 2000; Waldman et al. 1996a). Size and age that individuals leave their natal river for the marine environment is variable at the individual and geographic level; age and size of maturity is similarly variable. Upon reaching the sub-adult phase, individuals enter the marine environment, mixing with adults and sub-adults from other river systems (Bain 1997; Dovel and Berggren 1983; Hatin et al. 2007; Mccord et al. 2007; NMFS 2017a). Once sub-adult Atlantic sturgeon have reached maturity/the adult stage, they will remain in marine or estuarine waters, only returning far upstream to the spawning areas when they are ready to spawn (ASSRT 2007; Bain 1997; Breece et al. 2016; Dunton et al. 2012; Dunton et al. 2015; Savoy and Pacileo 2003).

The life history of Atlantic sturgeon can be divided up into seven general categories as described in Table 14 below (adapted from ASSRT 2007). Note that the size and duration information presented in the table below should be considered a generalization and there is individual and geographic variation.

**Table 14. Descriptions of Atlantic sturgeon life history stages**

Age Class	Typical Size	General Duration	Description
<b>Egg</b>	~2 mm – 3 mm diameter (Van Eenennaam et al. 1996)(p. 773)	Hatching occurs ~3-6 days after egg deposition and fertilization (ASSRT 2007)(p. 4))	Fertilized or unfertilized
<b>Yolk-sac larvae (YSL)</b>	~6mm – 14 mm (Bath et al. 1981)(pp. 714-715))	8-12 days post hatch (ASSRT 2007)(p. 4))	Negative photo-taxis, nourished by yolk sac
<b>Post yolk-sac larvae (PYSL)</b>	~14mm – 37mm (Bath et al. 1981)(pp. 714-715))	12-40 days post hatch	Free swimming; feeding; Silt/sand bottom, deep channel; fresh water
<b>Young of Year (YOY)</b>	0.3 grams <410mm TL	From 40 days to 1 year	Fish that are > 40 days and < one year; capable of capturing and consuming live food

<b>Juveniles</b>	>410mm and <760mm TL	1 year to time at which first coastal migration is made	Fish that are at least age 1 and are not sexually mature and do not make coastal migrations.
<b>Subadults</b>	>760 mm and <1500 mm TL	From first coastal migration to sexual maturity	Fish that are not sexually mature but make coastal migrations
<b>Adults</b>	>1500 mm TL	Post-maturation	Sexually mature fish

Atlantic sturgeon feed primarily on soft-bodied benthic invertebrates like polychaetes, isopods, and amphipods in the saltwater environment, while in freshwater, they feed on oligochaetes, gammarids, mollusks, insects, and chironomids (Brosse et al. 2002; Collins et al. 2008; Guilbard et al. 2007; Haley 1998; Haley 1999; Johnson et al. 1997; Moser and Ross 1995; Savoy 2007). The sturgeon "roots" in the sand or mud with its snout, like a pig, to dislodge worms and mollusks that it sucks into its protrusible mouth, along with considerable amounts of mud. The Atlantic sturgeon has a stomach with very thick, muscular walls that resemble the gizzard of a bird. This enables it to grind such food items as mollusks and gastropods (MSPO 1993). Diets vary latitudinally and seasonally, though universally researchers have found that polychaetes constitute a major portion of Atlantic sturgeon diets. In North Carolina, Moser and Ross (1995) determined Atlantic sturgeon fed on 32% polychaetes, 28% isopods, 12% mollusks, and then other items.

## 5.9.2 Population Dynamics

A population estimate was derived from the NEAMAP trawl surveys, which have been conducted (spring and fall) since fall 2007 from Cape Cod, Massachusetts to Cape Hatteras, North Carolina in nearshore waters at depths up to 60 ft. (18.3 m) across 150 stations. For this Opinion, we are relying on the population estimates derived from the NEAMAP swept area biomass assuming a 50% catchability (i.e., net efficiency x availability) rate. We consider that the NEAMAP surveys sample an area utilized by Atlantic sturgeon but do not sample all the locations and times where Atlantic sturgeon are present. We also consider that the trawl net captures some, but likely not all, of the Atlantic sturgeon present in the sampling area. Therefore, we assume that net efficiency and the fraction of the population exposed to the NEAMAP surveys in combination result in a 50% catchability (NMFS 2013). The 50% catchability assumption reasonably accounts for the robust, yet not complete, sampling of the Atlantic sturgeon oceanic temporal and spatial ranges and the documented high rates of encounter with NEAMAP survey gear. As these estimates are derived directly from empirical data with fewer assumptions than have been required to model Atlantic sturgeon populations to date, we believe these estimates continue to serve as the best available information.

Based on the above approach, the overall abundance of Atlantic sturgeon in U.S. Atlantic waters is estimated to be 67,776 fish (see table 16 in Kocik et al. 2013). Based on genetic frequencies of occurrence in the sampled area, this overall population estimate was subsequently partitioned by DPS (Table 15). Given the proportion of adults to subadults in the NMFS NEFSC observer data (approximate ratio of 1:3), we have also estimated the number of adults and subadults originating from each DPS. However, this cannot be considered an estimate of the total number of subadults because it only considers those subadults that are of a size that are present and vulnerable to capture in commercial trawl and gillnet gear in the marine environment.

### **Table 15. Calculated population estimates based upon the NEAMAP survey swept area model, assuming 50% efficiency**

<b>DPS</b>	<b>Estimated Ocean Population Abundance</b>	<b>Estimated Ocean Population of Adults</b>	<b>Estimated Ocean Population of Subadults (of size vulnerable to capture in fisheries)</b>
Gulf of Maine	7,455	1,864	5,591
New York Bight	34,566	8,642	25,925
Chesapeake Bay	8,811	2,203	6,608
Carolina	1,356	339	1,017
South Atlantic	14,911	3,728	11,183
Canada	678	170	509

It is important to note, the NEAMAP-based estimates do not include young-of-the-year (YOY) fish and juveniles in the rivers; therefore, the NEAMAP-based estimates underestimate the total population size as they do not account for multiple year classes of Atlantic sturgeon that do not occur in the marine environment where the NEAMAP surveys take place. The NEAMAP surveys are conducted in waters that include the preferred depth ranges of subadult and adult Atlantic sturgeon and take place during seasons that coincide with known Atlantic sturgeon coastal migration patterns in the ocean. However, the estimated number of subadults in marine waters is a minimum count because it only considers those subadults that are captured in a portion of the action area and are present in the marine environment, which is only a fraction of the total number of subadults. In regards to adult Atlantic sturgeon, the estimated population in marine waters is also a minimum count as the NEAMAP surveys sample only a portion of the action area, and therefore a portion of the Atlantic sturgeon's range.

Precise estimates of population growth rate (intrinsic rates) are unknown for the 5 listed DPSs of Atlantic sturgeon due to a lack of long-term abundance data. The Commission's 2017 stock assessment referenced a population viability assessment (PVA) that was done to determine population growth rates for the 5 DPSs based on a few long-term survey programs, but most results were statistically insignificant or utilized a model for which the available did not or poorly fit. In any event, the population growth rates reported from that PVA ranged from -1.8% to 4.9% (ASMFC 2017).

The genetic diversity of Atlantic sturgeon throughout its range has been well-documented (ASSRT 2007; Bowen and Avise 1990; O'Leary et al. 2014; Ong et al. 1996; Waldman et al. 1996b; Waldman and Wirgin 1998). Overall, these studies have consistently found populations to be genetically diverse, and the majority can be readily differentiated. Relatively low rates of gene flow reported in population genetic studies (Fritts et al. 2016; Savoy et al. 2017) indicate that Atlantic sturgeon return to their natal river to spawn, despite extensive mixing in coastal waters.



The marine range of U.S. Atlantic sturgeon extends from Labrador, Canada, to Cape Canaveral, Florida. The Atlantic sturgeon's historic range included major estuarine and riverine systems that spanned from Hamilton Inlet on the coast of Labrador, Canada, to the Saint Johns River in Florida (ASSRT 2007; Smith and Clugston 1997). Atlantic sturgeon have been documented as far south as Bermuda and Venezuela. Historically, Atlantic sturgeon were present in approximately 38 rivers in the United States from St. Croix, Maine, to the Saint Johns River, Florida, of which 35 rivers have been confirmed to have had historic spawning populations. Atlantic sturgeon presence is currently documented in 36 rivers, and spawning occurs in at least 21 of these (ASSRT 2007). Other estuaries along the U.S. Atlantic Coast formed by rivers that do not support Atlantic sturgeon spawning populations may still be important as rearing habitats. (Lee et al. 1980). As Atlantic sturgeon travel long distances in these waters, all 5 DPSs of Atlantic sturgeon have the potential to be anywhere in this marine range.

Based on a recent genetic mixed stock analysis by Kazyak et al. (2021), in which the CVOW-C project area falls within the "MID Offshore" area described in that paper, we expect Atlantic sturgeon in the portions of the action area north of Cape Hatteras to originate from the 5 DPSs at the following frequencies: New York Bight (55.3%), Chesapeake (22.9%), South Atlantic (13.6%), Carolina (5.8%), and Gulf of Maine (1.6%) DPSs. It is possible that a small fraction (0.7%) of Atlantic sturgeon in the area may be Canadian origin (Kazyak et al. 2021); Canadian-origin Atlantic sturgeon are not listed under the ESA. This represents the best available information on the likely genetic makeup of individuals occurring in the lease area, the cable routes and vessel transit routes north of Cape Hatteras. The portion of the action area south of Cape Hatteras falls with the "SOUTH" region described in Kazyak et al. (2021); Atlantic sturgeon in this portion of the action area are expected to be nearly all from the South Atlantic DPS (91.2%) and the Carolina DPS (6.2%), with few individuals from the Chesapeake Bay and New York Bight DPSs.

Based on fishery-independent, fishery dependent, tracking, and tagging data, Atlantic sturgeon appear to primarily occur inshore of the 164 ft (50 m) depth contour (Dunton et al. 2012; Dunton et al. 2010; Erickson et al. 2011; Laney et al. 2007; O'Leary et al. 2014; Stein et al. 2004a; Waldman et al. 2013; Wirgin et al. 2015a; Wirgin et al. 2015b). However, they are not restricted to these depths and excursions into deeper (e.g., 250 ft [75 m]) continental shelf waters have been documented (Colette and Klein-MacPhee 2002; Collins and Smith 1997; Erickson et al. 2011; Stein et al. 2004a; Timoshkin 1968). Data from fishery-independent surveys and tagging and tracking studies also indicate that some Atlantic sturgeon may undertake seasonal movements along the coast (Dunton et al. 2010; Erickson et al. 2011; Hilton et al. 2016; Oliver et al. 2013; Post et al. 2014; Wippelhauser 2012). For instance, studies found that satellite-tagged adult sturgeon from the Hudson River concentrated in the southern part of the Mid-Atlantic Bight, at depths greater than 66 ft (20 m), during winter and spring; while, in the summer and fall, Atlantic sturgeon concentrations shifted to the northern portion of the Mid-Atlantic Bight at depths less than 66 ft (20 m) (Erickson et al. 2011).

In the marine range, several marine aggregation areas occur adjacent to estuaries and/or coastal features formed by bay mouths and inlets along the U.S. eastern seaboard (i.e., waters off North Carolina; Chesapeake Bay; Delaware Bay; New York Bight; Massachusetts Bay; Long Island Sound; and Connecticut and Kennebec River Estuaries). Depths in these areas are generally no greater than 82 ft (25 m) (Bain et al. 2000; Dunton et al. 2010; Erickson et al. 2011; Laney et al. 2007; O'Leary et al. 2014; Oliver et al. 2013; Savoy and Pacileo 2003; Stein et al. 2004a; Waldman et al. 2013; Wippelhauser 2012; Wippelhauser and Squiers 2015). Although additional studies are still needed to clarify why Atlantic sturgeon aggregate at these sites, there is some indication that they may serve as thermal refugia, wintering sites, or marine foraging areas (Dunton et al. 2010; Erickson et al. 2011; Stein et al. 2004a).

### 5.9.3 Status

Atlantic sturgeon were once present in 38 river systems and, of these, spawned in 35 (ASSRT 2007). They are currently present in 36 rivers and are probably present in additional rivers that provide sufficient forage base, depth, and access (ASSRT 2007). The benchmark stock assessment evaluated evidence for spawning tributaries and sub-populations of U.S. Atlantic sturgeon in 39 rivers. They confirmed (eggs, embryo, larvae, or YOY observed) spawning in ten rivers, considered spawning highly likely (adults expressing gametes, discrete genetic composition) in nine rivers, and suspected (adults observed in upper reaches of tributaries, historical accounts, presence of resident juveniles) spawning in six rivers. Spawning in the remaining rivers was unknown (10) or suspected historical (4) (ASMFC 2017). The decline in abundance of Atlantic sturgeon has been attributed primarily to the large U.S. commercial fishery, which existed for the Atlantic sturgeon through the mid-1990s. Based on management recommendations in the ISFMP, adopted by the Commission in 1990, commercial harvest in Atlantic coastal states was severely restricted and ultimately eliminated from most coastal states (ASMFC 1998a). In 1998, the Commission placed a 20-40 year moratorium on all Atlantic sturgeon fisheries until the spawning stock could be restored to a level where 20 subsequent year classes of adult females were protected (ASMFC 1998a; ASMFC 1998c). In 1999, NMFS closed the U.S. EEZ to Atlantic sturgeon retention, pursuant to the ACA (64 FR 9449; February 26, 1999). However, many state fisheries for sturgeon were closed prior to this.

The most significant threats to Atlantic sturgeon are incidental catch, dams that block access to spawning habitat in southern rivers, poor water quality, dredging of spawning areas, water withdrawals from rivers, and vessel strikes (NMFS 2022b; NMFS 2022c; SSSRT 2010). Climate change related impacts on water quality (e.g., temperature, salinity, dissolved oxygen, contaminants) also have the potential to affect Atlantic sturgeon populations using impacted river systems.

The Atlantic States Marine Fisheries Commission released a benchmark stock assessment for Atlantic sturgeon in October 2017 (ASMFC 2017). Based on historic removals and estimated effective population size, the 2017 stock assessment concluded that all 5 Atlantic sturgeon DPSs are depleted relative to historical levels. However, the 2017 stock assessment does provide some evidence of population recovery at the coastwide scale, and mixed population recovery at the DPS scale (ASMFC 2017). The 2017 stock assessment also concluded that a variety of factors (i.e., bycatch, habitat loss, and ship strikes) continue to impede the recovery rate of Atlantic sturgeon (ASMFC 2017).

Despite the depleted status, the Commission's assessment did include signs that the coastwide index is above the 1998 value (95% probability). Total mortality from the tagging model was very low at the coastwide level. Small sample sizes made mortality estimates at the DPS level more difficult. By DPS, the assessment concluded that there was a 51% probability that the Gulf of Maine DPS abundance has increased since 1998 but a 74% probability that mortality for this DPS exceeds the mortality threshold used for the assessment. There is a relatively high (75%) probability that the New York Bight DPS abundance has increased since 1998, and a 31% probability that mortality exceeds the mortality threshold used for the assessment. There is also a relatively high (67%) probability that the Carolina DPS abundance has increased since 1998, and a relatively high probability (75%) that mortality for this DPS exceeds the mortality threshold used in the assessment. However, the index from the Chesapeake Bay DPS (highlighted red) only had a 36% chance of being above the 1998 value and a 30% probability that the mortality for this DPS exceeds the mortality threshold for the assessment. There was not enough information available to assess the abundance for the South Atlantic DPS relative to the 1998 moratorium, but the assessment did conclude that there was 40% probability that the mortality for this DPS exceeds the mortality threshold used in the assessment (ASMFC 2017).

#### 5.9.4 Critical Habitat

Critical habitat has been designated for the 5 DPSs of Atlantic sturgeon (82 FR 39160, August 17, 2017) in rivers of the eastern United States; however, critical habitat is not designated in the action area (82 FR 39160).

#### 5.9.5 DPS Specific Information

##### 5.9.5.1 Gulf of Maine DPS

The Gulf of Maine DPS includes the following: all anadromous Atlantic sturgeons that are spawned in the watersheds from the Maine/Canadian border and, extending southward, all watersheds draining into the Gulf of Maine as far south as Chatham, MA. The Gulf of Maine DPS historically supported at least 4 spawning subpopulations in the Androscoggin, Kennebec, Merrimack, Penobscot, and Sheepscot Rivers (ASSRT 2007). However, today it is suspected that only 2 extant subpopulations exist (Penobscot and Kennebec; ASSRT 2007). Spawning occurs in the Kennebec River. The capture of a larval Atlantic sturgeon in the Androscoggin River below the Brunswick Dam in the spring of 2011 indicates spawning may also occur in that river. Despite the presence of suitable spawning habitat in a number of other rivers, there is no evidence of recent spawning in the remaining rivers. Atlantic sturgeons that are spawned elsewhere continue to use habitats within all of these rivers as part of their overall marine range (ASSRT 2007). The movement of subadult and adult sturgeon between rivers, including to and from the Kennebec River and the Penobscot River, demonstrates that coastal and marine migrations are key elements of Atlantic sturgeon life history for the Gulf of Maine DPS (ASSRT 2007; Fernandes et al. 2010).

The current status of the Gulf of Maine DPS is affected by historical and modern fisheries dating as far back as the 1800s (ASMFC 2007; Squiers and Smith 1979; Stein et al. 2004b). Incidental capture of Atlantic sturgeon in state and Federal fisheries continues today. As explained above, we have estimates of the number of subadults and adults that are killed as a result of bycatch in fisheries authorized under Northeast Fishery Management Plans. At this time, we are not able to quantify the impacts from other threats or estimate the number of individuals killed as a result of other anthropogenic threats. Habitat disturbance and direct mortality from anthropogenic sources are the primary concerns.

Some of the impacts from the threats that contributed to the decline of the Gulf of Maine DPS have been removed (e.g., directed fishing), or reduced as a result of improvements in water quality and removal of dams (e.g., the Edwards Dam on the Kennebec River in 1999, the Veazie Dam on the Penobscot River). There are strict regulations on the use of fishing gear in Maine state waters that incidentally catch sturgeon. In addition, there have been reductions in fishing effort in state and Federal waters, which most likely would result in a reduction in bycatch mortality of Atlantic sturgeon. A significant amount of fishing in the Gulf of Maine is conducted using trawl gear, which is known to have a much lower mortality rate for Atlantic sturgeon caught in the gear compared to sink gillnet gear (ASMFC 2007). Atlantic sturgeon from the GOM DPS are not commonly taken as bycatch in areas south of Chatham, MA, with only 8% (e.g., 7 of the 84 fish) of interactions observed in the Mid Atlantic/Carolina region being assigned to the Gulf of Maine DPS (Wirgin and King 2011). Tagging results also indicate that Gulf of Maine DPS fish tend to remain within the waters of the Gulf of Maine and only occasionally venture to points south. However, data on Atlantic sturgeon incidentally caught in trawls and intertidal fish weirs fished in the Minas Basin area of the Bay of Fundy (Canada) indicate that approximately 35% originated from the Gulf of Maine DPS (Wirgin et al. 2012).

Studies have shown that in order to rebuild, Atlantic sturgeon can only sustain low levels of bycatch and other anthropogenic mortality (ASMFC 2007; Boreman 1997; Brown and Murphy 2010; Kahnle et al. 2007). NMFS has determined that the Gulf of Maine DPS is at risk of becoming endangered in the foreseeable future

throughout all of its range (i.e., is a threatened species) based on the following: (1) significant declines in population sizes and the protracted period during which sturgeon populations have been depressed; (2) the limited amount of current spawning; and, (3) the impacts and threats that have and will continue to affect recovery.

In 2018, we announced the initiation of a 5-year review for the Gulf of Maine DPS. We reviewed and considered new information for the Gulf of Maine DPS that has become available since this DPS was listed as threatened in February 2012. We completed the 5-year review for the Gulf of Maine DPS in February 2022 (NMFS 2022b). Based on the best scientific and commercial data available at the time of the review, we concluded that no change to the listing status is warranted.

#### **5.9.5.2 New York Bight DPS**

The New York Bight DPS includes the following: all anadromous Atlantic sturgeon spawned in the watersheds that drain into coastal waters from Chatham, MA to the Delaware-Maryland border on Fenwick Island. Within this range, Atlantic sturgeon historically spawned in the Connecticut, Delaware, Hudson, and Taunton Rivers (ASSRT 2007; Murawski and Pacheco 1977; Secor 2002). The New York Bight, ranging from Cape Cod to the Delmarva Peninsula, historically supported 4 or more spawning subpopulations, but currently this DPS only supports 2 known spawning subpopulations: Delaware River and Hudson River. There is no recent evidence (within the last 15 years) of spawning in the Taunton River (ASSRT 2007). Atlantic sturgeon that are spawned elsewhere continue to use habitats within the Connecticut and Taunton Rivers as part of their overall marine range (ASSRT 2007; Savoy 2007; Wirgin and King 2011).

In 2014, several presumed age-0 Atlantic sturgeon were captured in the Connecticut River; the available information indicates that successful spawning took place in 2013 by a small number of adults. Genetic analysis of the juveniles indicates that the adults were likely migrants from the South Atlantic DPS (Savoy et al. 2017). As noted by the authors, this conclusion is counter to prevailing information regarding straying of adult Atlantic sturgeon. As these captures represent the only contemporary records of possible natal Atlantic sturgeon in the Connecticut River and the genetic analysis is unexpected, more information is needed to establish the frequency of spawning in the Connecticut River and whether there is a unique Connecticut River population of Atlantic sturgeon.

The abundance of the Hudson River Atlantic sturgeon riverine population prior to the onset of expanded exploitation in the 1800s is unknown but has been conservatively estimated at 10,000 adult females (Secor 2002). Current abundance is likely at least one order of magnitude smaller than historical levels (ASSRT 2007; Kahnle et al. 2007; NMFS 2007; Secor 2002). As described above, an estimate of the mean annual number of mature adults (863 total; 596 males and 267 females) was calculated for the Hudson River riverine population based on fishery-dependent data collected from 1985-1995 (Kahnle et al. 2007). Kahnle et al. (1998; 2007) also showed that the level of fishing mortality from the Hudson River Atlantic sturgeon fishery during the period of 1985-1995 exceeded the estimated sustainable level of fishing mortality for the riverine population and may have led to reduced recruitment. A decline in the abundance of young Atlantic sturgeon appeared to occur in the mid to late 1970s followed by a secondary drop in the late 1980s (ASMFC 2010; Kahnle et al. 1998; Sweka et al. 2007). At the time of listing, catch-per-unit-effort (CPUE) data suggested that recruitment remained depressed relative to catches of juvenile Atlantic sturgeon in the estuary during the mid-late 1980s (ASMFC 2010; Sweka et al. 2007). In examining the CPUE data from 1985-2007, there are significant fluctuations during this time. There appears to be a decline in the number of juveniles between the late 1980s and early 1990s while the CPUE is generally higher in the 2000s as compared to the 1990s. Given the significant annual fluctuation, it is difficult to discern any trend. Despite the CPUEs from 2000-2007 being generally higher than those from 1990-1999, they are low compared to the late 1980s. Standardized mean catch per net set from the

NYSDEC juvenile Atlantic sturgeon survey have had a general increasing trend from 2006 – 2015, with the exception of a dip in 2013.

Kazyak et al. (2020) used side scan sonar technology in conjunction with detections of previously tagged Atlantic sturgeon to estimate a Hudson River spawning run size of 466 sturgeon (95% CRI = 310-745) in 2014. The estimates of effective population size for the Hudson River spawning population range from 144 to 198 (NMFS 2022c). Long-term surveys indicate that the Hudson River subpopulation has been stable and/or slightly increasing since 1995 (ASSRT 2007). Recent analyses suggest that the abundance of juvenile Atlantic sturgeon belonging to the Hudson River spawning population has increased, with double the average catch rate for the period from 2012-2019 compared to the previous 8 years, from 2004-2011 (Pendleton and Adams 2021).

In addition to capture in fisheries operating in Federal waters, bycatch and mortality also occur in state fisheries; however, the primary fishery (shad) that impacted juvenile sturgeon in the Hudson River, has now been closed and there is no indication that it will reopen soon. In the Hudson River, sources of potential mortality include vessel strikes and entrainment in dredges. Impingement at water intakes, including the Danskammer, Roseton, and Indian Point power plants has been documented in the past; all three of these facilities have recently shut down. Recent information from surveys of juveniles (see above) indicates that the number of young Atlantic sturgeon in the Hudson River is increasing compared to recent years, but is still low compared to the 1970s. There is currently not enough information regarding any life stage to establish a trend for the entire Hudson River population.

There is no abundance estimate for the Delaware River population of Atlantic sturgeon. Harvest records from the 1800s indicate that this was historically a large population with an estimated 180,000 adult females prior to 1890 (Secor 2002; Secor and Waldman. 1999). Sampling in 2009 to target young-of- the year (YOY) Atlantic sturgeon in the Delaware River (i.e., natal sturgeon) resulted in the capture of 34 YOY, ranging in size from 178 to 349 mm TL (Fisher 2009) and the collection of 32 YOY Atlantic sturgeon in a separate study (Brundage and O'Herron in Calvo et al. 2010)(Brundage and O'Herron in Calvo et al. 2010)(Brundage and O'Herron in Calvo et al. 2010)(Brundage and O'Herron in Calvo et al. 2010)(Brundage and O'Herron in Calvo et al. 2010)(Brundage and O'Herron in Calvo et al. 2010). Genetics information collected from 33 of the 2009-year class YOY indicates that at least three females successfully contributed to the 2009-year class (Fisher 2011). Therefore, while the capture of YOY in 2009 provides evidence that successful spawning is still occurring in the Delaware River, the relatively low numbers suggest the existing riverine population is limited in size. Hale et al. (2016) suggests that a spawning population of Atlantic sturgeon exists in the Delaware River and that some level of early juvenile recruitment is continuing to persist despite current depressed population levels. They estimated that 3,656 (95% confidence interval from 1,935 to 33,041) juveniles (ages 0 to 1) used the Delaware River estuary as a nursery in 2014. These findings suggest that the Delaware River spawning subpopulation contributes more to the New York Bight DPS than was formerly considered. The estimates of effective population size for the Delaware River spawning population range from 40 to 109 (NMFS 2022c).

Some of the impacts from the threats that contributed to the decline of the New York Bight DPS have been removed (e.g., directed fishing) or reduced as a result of improvements in water quality since passage of the Clean Water Act (CWA). In addition, there have been reductions in fishing effort in state and Federal waters, which may result in a reduction in bycatch mortality of Atlantic sturgeon. Nevertheless, areas with persistent, degraded water quality, habitat impacts from dredging, continued bycatch in state and Federally managed fisheries, and vessel strikes remain significant threats to the New York Bight DPS.

In the marine range, New York Bight DPS Atlantic sturgeon are incidentally captured in Federal and state managed fisheries, reducing survivorship of subadult and adult Atlantic sturgeon (ASMFC 2007; Stein et al.

2004a). Currently available estimates indicate that at least 4% of adults may be killed as a result of bycatch in fisheries authorized under Federal Northeast FMPs. Based on mixed stock analysis results presented by (Wirgin and King 2011), over 40% of the Atlantic sturgeon bycatch interactions in the Mid Atlantic Bight region were sturgeon from the New York Bight DPS. Individual-based assignment and mixed stock analysis of samples collected from sturgeon captured in Canadian fisheries in the Bay of Fundy indicated that approximately 1-2% were from the New York Bight DPS. At this time, we are not able to quantify the impacts from other threats or estimate the number of individuals killed as a result of other anthropogenic threats.

Riverine habitat may be impacted by dredging and other in-water activities, disturbing spawning habitat, and altering the benthic forage base. Both the Hudson and Delaware rivers have navigation channels that are maintained by dredging. Dredging is also used to maintain channels in the nearshore marine environment. Dredging outside of Federal channels and in-water construction occurs throughout the New York Bight region. While some dredging projects operate with observers present to document fish mortalities many do not. We have reports of 1 Atlantic sturgeon entrained during hopper dredging operations in Ambrose Channel, New Jersey, and a number of Atlantic sturgeon have been killed during Delaware River channel maintenance and deepening activities.

In the Hudson and Delaware Rivers, dams do not block access to historical habitat. The Holyoke Dam on the Connecticut River blocks further upstream passage; however, the extent that Atlantic sturgeon would historically have used habitat upstream of Holyoke is unknown. Connectivity may be disrupted by the presence of dams on several smaller rivers in the New York Bight region. Because no Atlantic sturgeon occur upstream of any hydroelectric projects in the New York Bight region, passage over hydroelectric dams or through hydroelectric turbines is not a source of injury or mortality in this area.

New York Bight DPS Atlantic sturgeon may also be affected by degraded water quality. In general, water quality has improved in the Hudson and Delaware over the past decades (Lichter et al. 2006). Both the Hudson and Delaware rivers, as well as other rivers in the New York Bight region, were heavily polluted in the past from industrial and sanitary sewer discharges. While water quality has improved and most discharges are limited through regulations, many pollutants persist in the benthic environment. This can be particularly problematic if pollutants are present on spawning and nursery grounds as developing eggs and larvae are particularly susceptible to exposure to contaminants.

Vessel strikes occur in the Delaware and Hudson rivers. Delaware State University (DSU) collaborated with the Delaware Division of Fish and Wildlife (DDFW) in an effort to document vessel strikes in 2005. Approximately 200 reported carcasses with over half being attributed to vessel strikes based on a gross examination of wounds have been documented through 2019 (DiJohnson 2019). One hundred thirty-eight (138) sturgeon carcasses were observed on the Hudson River and reported to the NYSDEC between 2007 and 2015. Of these, 69 are suspected of having been killed by vessel strike. Genetic analysis has not been completed on any of these individuals to date, given that the majority of Atlantic sturgeon in the Hudson River belong to the New York Bight DPS; we assume that the majority of the dead sturgeon reported to NYSDEC belonged to the New York Bight DPS. Given the time of year in which the fish were observed (predominantly May through July), it is likely that many of the adults were migrating through the river to the spawning grounds.

Studies have shown that to rebuild, Atlantic sturgeon can only sustain low levels of anthropogenic mortality (ASMFC 2007; Boreman 1997; Brown and Murphy 2010; Kahnle et al. 2007). There are no empirical abundance estimates of the number of Atlantic sturgeon in the New York Bight DPS. We determined that the New York Bight DPS is currently at risk of extinction due to: (1) precipitous declines in population sizes and the protracted period in which sturgeon populations have been depressed; (2) the limited amount of current spawning; and (3) the impacts and threats that have and will continue to affect population recovery.

The New York Bight DPS demographic risk is categorized as “high” due to its low productivity (e.g., relatively few adults compared to historical levels and irregular spawning success), low abundance (e.g., only a few known spawning populations and low DPS abundance, overall), and limited spatial distribution (e.g., limited spawning habitat within each of the few known rivers that support spawning; NMFS 2022c). The New York Bight DPS’ potential to recover is, however, also high because man-made threats that have a major impact on the species’ ability to persist have been identified (e.g., bycatch in Federally-managed fisheries, vessel strikes), the DPS’ response to those threats are well understood, management or protective actions to address major threats are primarily under U.S. jurisdiction or authority, and management or protective actions are technically feasible with respect to reducing fisheries bycatch even if they require further testing (e.g., gear modifications to minimize dredge or fishing gear interactions; NMFS 2022c).

In 2018, we announced the initiation of a 5-year review for the New York Bight DPS. We reviewed and considered new information for the New York Bight DPS that has become available since this DPS was listed as endangered in February 2012. We completed the 5-year review for the DPS in February 2022 (NMFS 2022c). Based on the best scientific and commercial data available at the time of the review, we concluded that no change to the listing status is warranted.

### **5.9.5.3 Chesapeake Bay DPS**

The Chesapeake Bay DPS includes the following: all anadromous Atlantic sturgeon that spawn or are spawned in the watersheds that drain into the Chesapeake Bay and into coastal waters from the Delaware-Maryland border on Fenwick Island to Cape Henry, Virginia. The marine range of Atlantic sturgeon from the Chesapeake Bay DPS extends from Hamilton Inlet, Labrador, Canada, to Cape Canaveral, Florida. Historically, Atlantic sturgeon were common throughout the Chesapeake Bay and its tributaries (Kahnle et al. 1998). Atlantic sturgeon historically spawned in the Susquehanna, Potomac, James, York, Rappahannock, and Nottoway Rivers (ASSRT 2007). Based on U.S. Fish Commission landings data, approximately 20,000 adult female Atlantic sturgeon inhabited the Chesapeake Bay and its tributaries prior to development of a commercial fishery in 1890 (NMFS 2007). Based on the review by (Oakley 2003), 100% of Atlantic sturgeon habitat is currently accessible in these rivers since most of the barriers to passage (i.e., dams) are located upriver of where spawning is expected to have historically occurred (ASSRT 2007).

At the time of listing, the James River was the only known spawning river for the Chesapeake Bay DPS (ASSRT 2007; Balazik et al. 2012a; Hager 2011). Since the listing, evidence has been provided of both spring and fall spawning populations for the James River, as well as fall spawning in the Pamunkey River, a tributary of the York River, and fall spawning in Marshyhope Creek, a tributary of the Nanticoke River (Balazik and Musick 2015; Hager et al. 2014; Richardson and D. 2016). Kahn (2019) estimated a spawning run size of up to 222 adults (but with yearly variability) in the Pamunkey River, a tributary of the York River in Virginia, based on captures of tagged adults from 2013-2018. Detections of acoustically-tagged adult Atlantic sturgeon along with historical evidence suggests that Atlantic sturgeon belonging to the Chesapeake Bay DPS may be spawning in the Mattaponi and Rappahannock rivers as well (ASMFC 2017; Hilton et al. 2016; Kahn 2019). However, information for these populations is limited and the research is ongoing. New information for the Nanticoke River system suggests a small adult population based on a small total number of captures (i.e., 26 sturgeon) and the high rate of recapture across several years of study (Secor et al. 2021).

Several threats play a role in shaping the current status of Chesapeake Bay DPS Atlantic sturgeon. Historical records provide evidence of the large-scale commercial exploitation of Atlantic sturgeon from the James River and Chesapeake Bay in the 19th century (ASMFC 1998b; ASSRT 2007; Bushnoe et al. 2005; Secor 2002; Vladykov and Greely 1963) as well as subsistence fishing and attempts at commercial fisheries as early as the 17th century (ASSRT 2007; Balazik et al. 2010; Bushnoe et al. 2005; Secor 2002). Habitat disturbance caused

by in-river work, such as dredging for navigational purposes, is thought to have reduced available spawning habitat in the James River (ASSRT 2007; Bushnoe et al. 2005). At this time, we do not have information to quantify this loss of spawning habitat.

Decreased water quality also threatens Atlantic sturgeon of the Chesapeake Bay DPS, especially since the Chesapeake Bay system is vulnerable to the effects of nutrient enrichment due to a relatively low tidal exchange and flushing rate, large surface-to-volume ratio, and strong stratification during the spring and summer months (ASMFC 1998b; ASSRT 2007; Pyzik et al. 2004). These conditions contribute to reductions in dissolved oxygen levels throughout the Bay. The availability of nursery habitat, in particular, may be limited given the recurrent hypoxia (low dissolved oxygen) conditions within the Bay (Niklitschek and Secor 2005). Heavy industrial development during the 20th century in rivers inhabited by sturgeon impaired water quality and impeded these species' recovery. Although there have been improvements in some areas of the Bay's health, the ecosystem remains in poor condition. At this time, we do not have sufficient information to quantify the extent that degraded water quality affects habitat or individuals in the Chesapeake Bay watershed.

More than 100 Atlantic sturgeon carcasses have been salvaged in the James River since 2007 and additional carcasses were reported but could not be salvaged (Greenlee et al. 2019). Many of the salvaged carcasses had evidence of a fatal vessel strike. In addition, vessel struck Atlantic sturgeon have been found in other parts of the Chesapeake Bay DPS's range including in the York and Nanticoke river estuaries, within Chesapeake Bay, and near the mouth of the Bay since the DPS was listed as endangered (NMFS Sturgeon Salvage Permit Reporting; Secor et al. 2021).

In the marine and coastal range of the Chesapeake Bay DPS from Canada to Florida, fisheries bycatch in Federally and state-managed fisheries poses a threat to the DPS, reducing survivorship of subadults and adults and potentially causing an overall reduction in the spawning population (ASMFC 2007; ASSRT 2007; Stein et al. 2004a).

Areas with persistent, degraded water quality, habitat impacts from dredging, continued bycatch in U.S. state and Federally managed fisheries, Canadian fisheries, and vessel strikes remain significant threats to the Chesapeake Bay DPS of Atlantic sturgeon. Of the 35% of Atlantic sturgeon incidentally caught in the Bay of Fundy, about 1% were Chesapeake Bay DPS fish (Wirgin et al. 2012). Studies have shown that Atlantic sturgeon can only sustain low levels of bycatch mortality (ASMFC 2007; Boreman 1997; Kahnle et al. 2007). The Chesapeake Bay DPS is currently at risk of extinction given (1) precipitous declines in population sizes and the protracted period in which sturgeon populations have been depressed; (2) the limited amount of current spawning; and, (3) the impacts and threats that have and will continue to affect the potential for population recovery.

In 2018, we announced the initiation of a 5-year review for the Chesapeake Bay DPS. We reviewed and considered new information for the Chesapeake Bay DPS that has become available since this DPS was listed as endangered in February 2012. We completed the 5-year review for the Chesapeake Bay DPS in February 2022 (NMFS 2022a). Based on the best scientific and commercial data available at the time of the review, we concluded that no change to the listing status is warranted.

#### **5.9.5.4 Carolina DPS**

The Carolina DPS ranges from the Albemarle Sound to the Santee-Cooper River and consists of 7 extant subpopulations; 1 subpopulation (Sampit) is believed to be extirpated. The Carolina DPS includes all Atlantic sturgeon that spawn or are spawned in the watersheds (including all rivers and tributaries) from Albemarle Sound southward along the southern Virginia, North Carolina, and South Carolina coastal areas to Charleston



Harbor. The marine range of Atlantic sturgeon from the Carolina DPS extends from the Hamilton Inlet, Labrador, Canada, to Cape Canaveral, Florida. The current abundance of these subpopulations is likely less than 3% of their historical abundance based on 1890s commercial landings data (ASSRT 2007; Secor 2002).

Rivers in the Carolina DPS considered to be spawning rivers include the Neuse, Roanoke, Tar-Pamlico, Cape Fear, and Northeast Cape Fear rivers, and the Santee-Cooper and Pee Dee river (Waccamaw and Pee Dee rivers) systems. Historically, both the Sampit and Ashley Rivers were documented to have spawning populations at 1 time. However, the spawning population in the Sampit River is believed to be extirpated and the current status of the spawning population in the Ashley River is unknown. We have no information, current or historical, of Atlantic sturgeon using the Chowan and New Rivers in North Carolina. Recent telemetry work by Post et al. (2014) indicates that Atlantic sturgeon do not use the Sampit, Ashley, Ashepoo, and Broad-Coosawhatchie Rivers in South Carolina. These rivers are short, coastal plains rivers that most likely do not contain suitable habitat for Atlantic sturgeon. Fish from the Carolina DPS likely use other river systems than those listed here for their specific life functions.

Historical landings data indicate that between 7,000 and 10,500 adult female Atlantic sturgeon were present in North Carolina prior to 1890 (Armstrong and Hightower 2002; Secor 2002). Secor (2002) estimates that 8,000 adult females were present in South Carolina during that same period. Reductions from the commercial fishery and ongoing threats have drastically reduced the numbers of Atlantic sturgeon within the Carolina DPS. Currently, the Atlantic sturgeon spawning population in at least 1 river system within the Carolina DPS has been extirpated, with a potential extirpation in an additional system. The ASSRT estimated the remaining river populations within the DPS to have fewer than 300 spawning adults; this is thought to be a small fraction of historic population sizes (ASSRT 2007).

The Carolina DPS was listed as endangered under the ESA as a result of a combination of habitat curtailment and modification, overutilization (i.e., being taken as bycatch) in commercial fisheries, and the inadequacy of regulatory mechanisms in ameliorating these impacts and threats. The modification and curtailment of Atlantic sturgeon habitat resulting from dams, dredging, and degraded water quality is contributing to the status of the Carolina DPS. Dams have curtailed Atlantic sturgeon spawning and juvenile developmental habitat by blocking over 60% of the historical sturgeon habitat upstream of the dams in the Cape Fear and Santee-Cooper River systems. Water quality (velocity, temperature, and dissolved oxygen [DO]) downstream of these dams, as well as on the Roanoke River, has been reduced, which modifies and curtails the extent of spawning and nursery habitat for the Carolina DPS. Dredging in spawning and nursery grounds modifies the quality of the habitat and is further curtailing the extent of available habitat in the Cape Fear and Cooper Rivers, where Atlantic sturgeon habitat has already been modified and curtailed by the presence of dams. Reductions in water quality from terrestrial activities have modified habitat utilized by the Carolina DPS.

Water quality issues represent either a moderate or moderately high risk for most subpopulations within this DPS (ASSRT 2007). In the Pamlico and Neuse systems, nutrient-loading and seasonal anoxia are occurring, associated in part with concentrated animal feeding operations (CAFOs). Heavy industrial development and CAFOs have degraded water quality in the Cape Fear River. Water quality in the Waccamaw and Pee Dee rivers have been affected by industrialization and riverine sediment samples contain high levels of various toxins, including dioxins. Additional stressors arising from water allocation and climate change threaten to exacerbate water quality problems that are already present throughout the range of the Carolina DPS. The removal of large amounts of water from the system will alter flows, temperature, and DO. Existing water allocation issues will likely be compounded by population growth and potentially, by climate change. Climate change is also predicted to elevate water temperatures and exacerbate nutrient-loading, pollution inputs, and lower DO, all of which are current stressors to the Carolina DPS.

Commercial bycatch was a concern for all of the subpopulations examined by the Atlantic Sturgeon Status Review Team. Continued overutilization of Atlantic sturgeon as bycatch in commercial fisheries is an ongoing impact to the Carolina DPS. Overutilization of Atlantic sturgeon from directed fishing caused initial severe declines in Atlantic sturgeon populations in the Southeast, from which they have never rebounded. Further, continued overutilization of Atlantic sturgeon as bycatch in commercial fisheries is an ongoing impact to the Carolina DPS. Little data exists on bycatch in the Southeast and high levels of bycatch underreporting are suspected. Stress or injury to Atlantic sturgeon taken as bycatch but released alive may result in increased susceptibility to other threats, such as poor water quality (e.g., exposure to toxins and low DO). This may result in reduced ability to perform major life functions, such as foraging and spawning, or even post-capture mortality. The Cape Fear and Santee-Cooper rivers were found to have a moderately high risk (greater than 50%) of becoming endangered within the next 20 years due to impeded habitat from dams. The Cape Fear and Santee-Cooper are the most impeded rivers along the range of the species, where dams are located in the lower coastal plain and impede between 62% to 66% of the habitat available between the fall line and mouth of the river (ASSRT 2007). The Atlantic Sturgeon Status Review Team concluded that the limited habitat in which sturgeon could spawn and utilize for nursery habitat in these rivers likely leads to the instability of these subpopulations and to the entire DPS being at risk of endangerment.

As a wide-ranging anadromous species, Carolina DPS Atlantic sturgeon are subject to numerous Federal (U.S. and Canadian), state and provincial, and inter-jurisdictional laws, regulations, and agency activities. While these mechanisms have addressed impacts to Atlantic sturgeon through directed fisheries, there are currently no mechanisms in place to address the significant risk posed to Atlantic sturgeon from commercial bycatch. Though statutory and regulatory mechanisms exist that authorize reducing the impact of dams on riverine and anadromous species, such as Atlantic sturgeon, and their habitat, these mechanisms have proven inadequate for preventing dams from blocking access to habitat upstream and degrading habitat downstream. Further, water quality continues to be a problem in the Carolina DPS, even with existing controls on some pollution sources. Current regulatory regimes are not necessarily effective in controlling water allocation issues (e.g., no restrictions on interbasin water transfers in South Carolina, the lack of ability to regulate nonpoint source pollution, etc.).

#### **5.9.5.5 South Atlantic DPS**

The South Atlantic DPS includes all Atlantic sturgeon that spawn or are spawned in the watersheds (including all rivers and tributaries) of the Ashepoo, Combahee, and Edisto Rivers (ACE) Basin southward along the South Carolina, Georgia, and Florida coastal areas to the St. Johns River, Florida. This DPS historically supported 8 spawning subpopulations but currently supports 5 extant spawning populations (ASSRT 2007). Rivers known to have current spawning populations within the range of the South Atlantic DPS include the Combahee, Edisto, Savannah, Ogeechee, Altamaha, St. Marys, and Satilla Rivers. Telemetry work by Post et al. (2014) indicates that Atlantic sturgeon do not use the Sampit, Ashley, Ashepoo, and Broad-Coosawhatchie Rivers in South Carolina. These rivers are short, coastal plains rivers that most likely do not contain suitable habitat for Atlantic sturgeon. Post et al. (2014) also found Atlantic sturgeon only use the portion of the Waccamaw River downstream of Bull Creek. Due to manmade structures and alterations, spawning areas in the St. Johns River are not accessible and therefore do not support a reproducing population.

Secor (2002) estimates that 8,000 adult females were present in South Carolina prior to 1890. Prior to the collapse of the fishery in the late 1800s, the sturgeon fishery was the third largest fishery in Georgia. Secor (2002) estimated from U.S. Fish Commission landing reports that approximately 11,000 spawning females were likely present in the state prior to 1890.

Reductions from the commercial fishery and ongoing threats have drastically reduced the numbers of Atlantic sturgeon within the South Atlantic DPS. Currently, the Atlantic sturgeon spawning population in at least 1 river system within the South Atlantic DPS has been extirpated. The Altamaha River population of Atlantic sturgeon, with an estimated 343 adults spawning annually, is believed to be the largest population in the Southeast, yet is estimated to be only 6% of its historical population size. The ASSRT estimated the abundances of the remaining river populations within the DPS, each estimated to have fewer than 300 spawning adults, to be less than 1% of what they were historically (ASSRT 2007). The South Atlantic DPS was listed as endangered under the ESA as a result of a combination of habitat curtailment and modification, overutilization (i.e., being taken as bycatch) in commercial fisheries, and the inadequacy of regulatory mechanisms in ameliorating these impacts and threats.

The modification and curtailment of Atlantic sturgeon habitat resulting from dredging and degraded water quality is contributing to the status of the South Atlantic DPS. Maintenance dredging is currently modifying Atlantic sturgeon nursery habitat in the Savannah River and modeling indicates that the proposed deepening of the navigation channel will result in reduced DO and upriver movement of the salt wedge, curtailing spawning habitat. Dredging is also modifying nursery and foraging habitat in the St. Johns River. Reductions in water quality from terrestrial activities have modified habitat utilized by the South Atlantic DPS. Nonpoint source inputs are causing low DO in the Ogeechee River and in the St. Marys River, which completely eliminates juvenile nursery habitat in summer. Low DO has also been observed in the St. Johns River in the summer. Sturgeon are more sensitive to low DO and the negative (metabolic, growth, and feeding) effects caused by low DO increase when water temperatures are concurrently high, as they are within the range of the South Atlantic DPS. Additional stressors arising from water allocation and climate change threaten to exacerbate water quality problems that are already present throughout the range of the South Atlantic DPS. Large withdrawals of over 240 million gallons per day of water occur in the Savannah River for power generation and municipal uses. However, users withdrawing less than 100,000 gallons per day are not required to get permits, so actual water withdrawals from the Savannah and other rivers within the range of the South Atlantic DPS are likely much higher. The removal of large amounts of water from the system will alter flows, temperature, and DO. Water shortages and “water wars” are already occurring in the rivers occupied by the South Atlantic DPS and will likely be compounded in the future by population growth and potentially by climate change. Climate change is also predicted to elevate water temperatures and exacerbate nutrient-loading, pollution inputs, and lower DO, all of which are current stressors to the South Atlantic DPS.

Overutilization of Atlantic sturgeon from directed fishing caused initial severe declines in Atlantic sturgeon populations in the Southeast, from which they have never rebounded. Further, continued overutilization of Atlantic sturgeon as bycatch in commercial fisheries is an ongoing impact to the South Atlantic DPS. The loss of large subadults and adults as a result of bycatch impacts Atlantic sturgeon populations because they are a long-lived species, have an older age at maturity, have lower maximum fecundity values, and a large percentage of egg production occurs later in life. Little data exist on bycatch in the Southeast and high levels of bycatch underreporting are suspected. Further, a total population abundance for the DPS is not available, and it is therefore not possible to calculate the percentage of the DPS subject to bycatch mortality based on the available bycatch mortality rates for individual fisheries. However, fisheries known to incidentally catch Atlantic sturgeon occur throughout the marine range of the species and in some riverine waters as well. Because Atlantic sturgeon mix extensively in marine waters and may access multiple river systems, they are subject to being caught in multiple fisheries throughout their range. In addition, stress or injury to Atlantic sturgeon taken as bycatch but released alive may result in increased susceptibility to other threats, such as poor water quality (e.g., exposure to toxins and low DO). This may result in reduced ability to perform major life functions, such as foraging and spawning, or even post-capture mortality.

As a wide-ranging anadromous species, Atlantic sturgeon are subject to numerous Federal (U.S. and Canadian), state and provincial, and inter-jurisdictional laws, regulations, and agency activities. While these mechanisms have addressed impacts to Atlantic sturgeon through directed fisheries, there are currently no mechanisms in place to address the significant risk posed to Atlantic sturgeon from commercial bycatch. Though statutory and regulatory mechanisms exist that authorize reducing the impact of dams on riverine and anadromous species, such as Atlantic sturgeon, and their habitat, these mechanisms have proven inadequate for preventing dams from blocking access to habitat upstream and degrading habitat downstream. Further, water quality continues to be a problem in the South Atlantic DPS, even with existing controls on some pollution sources. Current regulatory regimes are not necessarily effective in controlling water allocation issues (e.g., no permit requirements for water withdrawals under 100,000 gallons per day in Georgia, no restrictions on interbasin water transfers in South Carolina, and the lack of ability to regulate nonpoint source pollution.)

#### **5.9.5.6 Recovery Planning**

A recovery plan has not been completed for the listed Atlantic sturgeon DPSs. However, a recovery outline has been prepared (NMFS 2018c) to serve as an initial recovery-planning document. In this, the recovery vision is stated, “Subpopulations of all five Atlantic sturgeon DPSs must be present across the historical range. These subpopulations must be of sufficient size and genetic diversity to support successful reproduction and recovery from mortality events. The recruitment of juveniles to the subadult and adult life stages must also increase and that increased recruitment must be maintained over many years. Recovery of these DPSs will require conservation of the riverine and marine habitats used for spawning, development, foraging, and growth by abating threats to ensure a high probability of survival into the future.” The recovery outline also includes steps that are expected to serve as an initial recovery action plan. These include protecting extant subpopulations and the species’ habitat through reduction of threats; gathering information through research and monitoring on current distribution and abundance; and addressing vessel strikes in rivers, the effects of climate change and bycatch.

## **6 ENVIRONMENTAL BASELINE**

The “environmental baseline” refers to the condition of the listed species or its designated critical habitat in the action area, without the consequences to the listed species or designated critical habitat caused by the proposed action. The environmental baseline includes the past and present impacts of all Federal, state, or private actions and other human activities in the action area, the anticipated impacts of all proposed Federal projects in the action area that have already undergone formal or early section 7 consultation, and the impact of state or private actions which are contemporaneous with the consultation in process (50 C.F.R. §402.02). The consequences to listed species or designated critical habitat from ongoing agency activities or existing agency facilities that are not within the agency’s discretion to modify are part of the environmental baseline (50 C.F.R. §402.02; 84 FR 44976 published August 27, 2019). The following information summarizes the principal natural and human-caused phenomena in the action area believed to affect the survival and recovery of the ESA-listed species.

There are a number of existing activities that regularly occur in various portions of the action area, including operation of vessels and Federal and state authorized fisheries. Other activities that occur occasionally or intermittently include scientific research, military activities, and geophysical and geotechnical surveys. There are also environmental conditions caused or exacerbated by human activities (i.e., water quality and noise) that may affect listed species in the action area. Some of these stressors result in mortality or serious injury to individual animals (e.g., vessel strike, fisheries), whereas others result in non-lethal impacts or impacts that are indirect. For all of the listed species considered here, given their extensive movements in and out of the action area and throughout their range, as well as the similarities of stressors throughout the action area and other parts

of their range, the status of the species in the action area is the same as the rangewide status presented in the Status of the Species section of this Opinion. Below, we describe the conditions of the action area, present a summary of the best available information on the use of the action area by listed species, and address the impacts to listed species of Federal, state, and private activities in the action area that meet the definition of “environmental baseline.” Future offshore wind projects, as well as activities caused by aspects of their development and operation, that are not the subjects of a completed consultation are not in the Environmental Baseline for the CVOW-C project. Rather, as a section 7 consultation is completed on a wind project, the effects of the action associated with that project would be considered in the Environmental Baseline for the next one in line for consultation.

## 6.1 Physical Environment

As described above in the description of the action area, the action area includes the project area, offshore export cable route corridors, project-related vessel routes (including to/from Europe, Canada, and the Gulf of Mexico) and the geographic extent of effects caused by project-related activities in those areas. The CVOW project area is located within multiple defined marine areas. The broadest area, the U.S. Northeast Shelf Large Marine Ecosystem, extends from the Gulf of Maine to Cape Hatteras, North Carolina (Kaplan 2011). The WFA and export cable routes are located within the Southern Mid-Atlantic Bight sub-region of the U.S. Northeast Shelf Ecosystem, which is distinct from other regions based on differences in productivity, species assemblages and structure, and habitat features (Cook and Auster 2007). The physical oceanography of this region is influenced by the seafloor, freshwater input from multiple rivers and estuaries, large-scale weather patterns, and tropical or winter coastal storm events. Weather-driven surface currents, tidal mixing, and estuarine outflow all contribute to driving water movement through the area (Kaplan 2011).

Sediments in the action are characterized by fine sand and gravel and sand/silt mixes. Prominent bottom features of the Mid-Atlantic Bight include a series of ridges and troughs. Water depths in the lease area range from 57 to 139 ft (18 to 42 m) mean lower low water and water depths along the offshore export cable route corridor range from 9.5 to 95.1 ft (2.9 to 29 m) mean lower low water (Dominion Energy 2022).

Sea surface temperatures in the lease area, as reported by the EPA (EPA 2012), ranged from 32°F to 88°F (0°C to 31°C), which corresponds to a depth-averaged annual water temperature of 56.39°F (13.55°C) as reported by Dominion Energy (Dominion Energy 2022). From the Naval Air Station Oceana, Dam Neck Annex range in Virginia state waters near the lease area, mean temperatures ranged from 43.34°F to 76.64°F (6.3°C to 24.8°C), depending on season and water depth (Dominion Energy 2022).

Seasonally, the Mid-Atlantic region experiences one of the largest transitions in stratification in any part of the ocean around the world, from the cold, well-mixed conditions in winter months to one of the largest top-to-bottom temperature differences in the summer (Castelao et al. 2010; Houghton et al. 1982; Miles et al. 2021). From spring through early summer, a strong thermocline develops across the length of the Mid-Atlantic Bight, isolating a continuous mid-shelf “cold pool” of water that extends from Nantucket to Cape Hatteras (Houghton et al. 1982; Kaplan 2011; Miles et al. 2021). Through summer, the thermocline strengthens and the cold pool becomes more stable as a result of surface heating and freshwater runoff (Castelao et al. 2010). The stable summer cold pool is a relatively slow-moving feature, which moves back and forth between the coast and shelf in response to surface wind forcing during periods of upwelling and downwelling. During the fall, more frequent strong wind events and decreasing surface heat over increasingly shorter daily daylight hours shifts the balance between heat input and vertical mixing. This results in reduced stratification, which ultimately breaks down the cold pool (Bigelow 1933; Castelao et al. 2010; Lentz 2017; Miles et al. 2021). These cold pool “seasons” of spring setup, summer stability, and fall breakdown are associated with and drivers of important biological and ecological processes, such as foraging and migration amongst marine vertebrates (Scales et al.

2014).

## 6.2 Underwater Noise

The ESA-listed species that occur in the action area are regularly exposed to several sources of sounds in the action area. Ambient noise includes the combination of biological, environmental, and anthropogenic sounds occurring within a particular region. In temperate marine environments including the WDA, major contributors to the overall acoustic ambient noise environment include the combination of surface wave action (generated by wind), weather events such as rain, lightning, marine organisms, and anthropogenic sound sources.

Anthropogenic sources include, but are not limited to maritime activities, vessel sounds, seismic surveys (exploration and research), and marine construction (dredging and pile-driving as well as the construction, operation, and decommissioning of offshore structures). These activities occur to varying degrees throughout the year. Many researchers have described behavioral responses of marine mammals to sounds produced by boats and vessels, as well as other sound sources such as dredging and construction (reviewed in Gomez et al. 2016; Nowacek et al. 2007). Most observations have been limited to short-term behavioral responses, which included avoidance behavior and temporary cessation of feeding, resting, or social interactions; however, in terrestrial species habitat abandonment can lead to more long-term effects, which may have implications at the population level (Barber et al. 2010). Cetaceans generate and rely on sound to navigate, hunt, and communicate with other individuals and anthropogenic sound can interfere with these important activities (Nowacek et al. 2007). Noise generated by human activity has the potential to affect sea turtles as well, although effects to sea turtles are not well understood. ESA-listed species may be impacted by either increased levels of anthropogenic-induced background sound or high intensity, short-term anthropogenic sounds.

Despite the potential for these impacts to affect individual ESA-listed marine mammals and sea turtles, information is not currently available to determine the potential population level effects of anthropogenic sound levels in the marine environment (MMC 2007). For example, we currently lack empirical data on how sound impacts growth, survival, reproduction, and vital rates, nor do we understand the relative influence of such effects on the population being considered. As a result, the consequences of anthropogenic sound on ESA-listed marine mammals and sea turtles at the population or species scale remain uncertain, although recent efforts have made progress establishing frameworks to consider such effects (NAS 2017).

The project area lies within a dynamic ambient noise environment, with natural background noise contributed by natural wind and wave action, a diverse community of vocalizing cetaceans, and other organisms. Anthropogenic noise sources, including commercial shipping traffic in high-use shipping lanes in proximity to the action area, also contribute ambient sound. Salisbury et al. (2018) used passive acoustic monitoring to explore ambient sound as part of a study of marine mammals specifically within the Virginia Offshore WEA. They found that ambient noise levels were relatively consistent among sites with some site variation, but data did not support seasonal drivers, rather some other combination of variables. Median 50% noise values across WEA sites were in the 70-100 dB range from 10-1000 Hz (Salisbury et al. 2018). In the right whale frequency band (71-224 Hertz), ambient noise exceeded 110 dB 50% of the time and 115 dB 14% of the time. Noise levels in the fin whale frequency band (18-28 Hertz) were lower than the other whale species, with noise levels exceeding 100 dB 50% of the time. Salisbury et al. (2018) note that the noise levels measured in the Virginia WEA for the right whale frequency band were louder than those found by Rice et al. (2014) at multiple sites in the Western North Atlantic.

Other studies off the coast of nearby states, provide additional ambient underwater noise measurements within the action area. Kraus et al. (2016) surveyed the ambient underwater noise environment in the RI/MA WEA, north of the CVOW-C project area, as part of a broader study of large whale and sea turtle use of marine habitats in the WEA. Acoustic monitoring sensor locations in and around the RI/MA WEA had water depths

ranging from approximately 98 to 197 ft (30 to 60 m), similar to the Project area, where water depths vary from 43 to 112 ft (13 to 34 m). Depending on location, ambient underwater sound levels within the RI/MA WEA varied from 96 to 103 dB in the 70.8- to 224-Hertz frequency band at least 50% of the recording time, with peak ambient noise levels reaching as high as 125 dB in proximity to the Narraganset Bay and Buzzards Bay shipping lanes (Kraus et al. 2016). Similar to the conclusions of Rice et al. (2014) for New Jersey, low-frequency sound from large marine vessel traffic in these and other major shipping lanes to the east (Boston Harbor) and south (New York) were the dominant sources of underwater noise in the RI/MA WEA.

Similarly, Bailey et al. (2018) conducted a 3-year passive acoustic monitoring study in and around the Maryland WEA to determine marine mammal habitat use and ambient noise levels. Equipment was deployed 11 – 64 km offshore of Ocean City, Maryland, at depths 20 – 42 m. Bailey et al. (2018) found that ambient noise levels varied by site and by season. Survey sites inshore and on the western edge of the WEA had median noise values ranging between 107.2 – 110.5 dB, whereas sites along the eastern edge of the WEA had median noise values ranging between 115.3 – 116.1 dB. All of the surveyed sites had noise levels exceeding the regulatory Marine Mammal Protection Act (MMPA) exposure thresholds for continuous noise sources threshold <less than 20% of the time during the 3-year survey. They point to elevated noise levels occurred low frequency bands (< 200 Hertz) and proximity of the survey area to shipping lanes as evidence anthropogenic noise, in particular shipping noise, as a main cause of ambient noise in the area (Bailey et al. 2018). The project and action areas for CVOW-C are similarly high traffic shipping areas (Aschettino et al. 2020; Salisbury et al. 2018).

Short-term increases in noise in the action area associated with vessel traffic and other activities, including geotechnical and geophysical surveys that have taken place in the past and will continue in the future in the portions of the action area that overlap with other offshore wind lease areas and/or potential cable routes. Exposure to these noise sources can result in temporary masking or temporary behavioral disturbance; however, in all cases, these effects are expected to be temporary and short-term (e.g., the seconds to minutes it takes for a vessel to pass by) and not result in any injury or mortality in the action area.

### **6.2.1 Vessel Sound**

Much of the increase in sound in the ocean environment is due to increased shipping, as vessels become more numerous and of larger tonnage (Hildebrand 2009; McKenna et al. 2012; NRC 2003). Commercial shipping continues to be a major source of low-frequency sound in the ocean, particularly in the Northern Hemisphere where the majority of vessel traffic occurs.

Although large vessels emit predominantly low frequency sound, studies report broadband sound from large cargo vessels above 2 kiloHertz. The low frequency sounds from large vessels overlap with many mysticetes' predicted hearing ranges (7 Hertz to 35 kiloHertz) and may mask their vocalizations and cause stress (NOAA 2018; Rolland et al. 2012). The broadband sounds from large vessels may interfere with important biological functions of odontocetes, including foraging (Blair et al. 2016; Holt 2008). At frequencies below 300 Hertz, ambient sound levels are elevated by 15 to 20 dB when exposed to sounds from vessels at a distance (McKenna et al. 2013). Analysis of sound from vessels revealed that their propulsion systems are a dominant source of radiated underwater sound at frequencies less than 200 Hertz (Ross 1976). Additional sources of vessel sound include rotational and reciprocating machinery that produces tones and pulses at a constant rate. Other commercial and recreational vessels also operate within the action area and may produce similar sounds, although to a lesser extent given their much smaller size.

Vessels produce unique acoustic signatures, although these signatures may change with vessel speed, vessel load, and activities that may be taking place on the vessel. Peak spectral levels for individual commercial vessels are in the frequency band of 10 to 50 Hertz and range from 195 dB re:  $\mu\text{Pa}^2\text{-s}$  at 1 m for fast-moving

(greater than 37 km per hour [20 knots]) supertankers to 140 dB re:  $\mu\text{Pa}^2\text{-s}$  at 1 m for small fishing vessels (NRC 2003). Small boats with outboard or inboard engines produce sound that is generally highest in the mid-frequency (1 to 5 kiloHertz) range and at moderate (150 to 180 dB re: one  $\mu\text{Pa}$  at 1 m) source levels (Erbe 2002; Gabriele et al. 2003; Kipple and Gabriele 2004). On average, sound levels are higher for the larger vessels, and increased vessel speeds result in higher sound levels. Measurements made over the period 1950 through 1970 indicated low frequency (50 Hertz) vessel traffic sound in the western North Atlantic Ocean was increasing by 0.55 dB per year (Ross 1976; Ross 1993; Ross 2005). Whether or not such trends continue today is unclear. Most data indicate vessel sound is likely still increasing (Hildebrand 2009). However, the rate of increase appears to have slowed in some areas (Chapman and Price 2011), and in some places, ambient sound including that produced by vessels appears to be decreasing (Miksis-Olds and Nichols 2016). Efforts are underway to better document changes in ambient sound (Haver et al. 2018), which will help provide a better understanding of current and future impacts of vessel sound on ESA-listed species. NOAA is working cooperatively with the ship building industry to find technologically-based solutions to reduce the amount of sound produced by commercial vessels.

Haver et al. (2019) compared underwater soundscapes at four U.S. national parks and marine sanctuaries. They found that the northwest Atlantic site (Stellwagen Bank National Marine Sanctuary, near Boston, MA) had highest sound levels [dBRMS(50 Hz–1.5 kHz) re 1  $\mu\text{Pa}$ ] compared to sites in the Northeast Pacific, South Pacific, and Caribbean, in part due to vessel traffic. Similar vessel traffic, and its associated noise, occur along the U.S. Atlantic coasts, particularly at ports. Discussion of vessel traffic in the lease area is further discussed in Section 6.5.1.

### 6.2.2 Seismic Surveys

There are seismic survey activities, including those that involve towed airgun arrays that may occur within the action area, but outside the project area. They are the primary exploration technique to locate hydrocarbon deposits, fault structure, and other geological hazards. Airguns contribute a massive amount of anthropogenic energy to the world's oceans ( $3.9 \times 10^{13}$  Joules cumulatively), second only to nuclear explosions (Moore and Angliss 2006). Although most energy is in the low-frequency range, airguns emit a substantial amount of energy up to 150 kiloHertz (Goold and Coates 2006). Seismic airgun noise can propagate substantial distances at low frequencies (e.g., Nieuwkirk et al. 2004). These activities may produce noise that could impact whales and sea turtles within the action area.

These airgun arrays generate intense low-frequency sound pressure waves capable of penetrating the seafloor and are fired repetitively at intervals of ten to 20 seconds for extended periods (NRC 2003). Most of the energy from the airguns is directed vertically downward, but significant sound emission also extends horizontally. Peak sound pressure levels from airguns usually reach 235 to 240 dB at dominant frequencies of five to 300 Hertz (NRC 2003). Most of the sound energy is at frequencies below 500 Hertz, which is within the hearing range of baleen whales and sperm whales (Nowacek et al. 2007). In the U.S., seismic surveys involving the use of airguns with the potential to take marine mammals are generally covered by incidental take authorizations under the MMPA, and if they involve ESA-listed species, undergo formal ESA section 7 consultation. In addition, when BOEM, the National Science Foundation (NSF), and U.S. Geological Survey (USGS) authorize, fund, and/or conduct these seismic survey activities in domestic, international, and foreign waters, and in doing so, consults with NMFS to ensure their actions do not jeopardize the continued existence of ESA-listed species or adversely modify or destroy designated critical habitat. More information on the effects of these activities on ESA-listed species, including authorized takes, can be found in recent biological opinions associated with these consultations.



The NSF funded and L-DEO conducted seismic surveys in the Northwest Atlantic Ocean on the R/V *Atlantis* in 2018 and R/V *Marcus G. Langseth* in 2014 through 2015 and recently off the coast of North Carolina on the R/V *Marcus G. Langseth* in 2023. The NSF plans to fund and L-DEO plans to conduct a high-energy seismic survey in the Northwest Atlantic Ocean off North Carolina and on the Blake Plateau on the R/V *Marcus G. Langseth* in 2023. The USGS funded and conducted seismic surveys in the Northwest Atlantic Ocean on the R/V *Marcus G. Langseth* in 2014 through 2015 and R/V *Hugh R. Sharp* in 2018. The biological opinions and subsequent monitoring reports for these activities concluded that effects from the airgun array would only result in ESA harassment of ESA-listed cetaceans and sea turtles. In 2018, we issued an opinion on the Bureau of Ocean Energy Management's issuance of 5 oil and gas permits for geological and geophysical seismic surveys off the U.S. coast of the Atlantic Ocean and NMFS Permits Division's issuance of associated IHAs. Presently, no oil and gas development is planned for the Mid-Atlantic Ocean and South Atlantic Ocean region as leasing consideration for waters off North Carolina, South Carolina, Georgia, and Florida were withdrawn. Each seismic survey includes a MMPA IHA and each is subject to a separate ESA section 7 consultation. The finalized consultations all resulted in a "no jeopardy" opinion.

### 6.3 Climate Change

There is a large and growing body of literature on past, present, and anticipated future impacts of global climate change, exacerbated and accelerated by human activities. Effects of climate change include sea level rise, increased frequency and magnitude of severe weather events, changes in air and water temperatures, and changes in precipitation patterns, all of which are likely to impact ESA-listed resources. NOAA's climate information portal provides basic background information on these and other measured or anticipated climate change effects (see <https://www.climate.gov>).

This section provides some examples of impacts to ESA-listed species and their habitats that have occurred or may occur in the action area as the result of climate change. Climate change, despite being a global phenomenon, is discussed in this section and in the cumulative effects section, because it is a current and ongoing effect which influences environmental quality within the action area now and in the future. NMFS's policy guidance with respect to climate change when evaluating an agency's action is to project climate effects over the timeframe of the action's consequences. We address climate change as it has affected ESA-listed species and continues to affect species, and we look to the foreseeable future to consider effects that we anticipate will occur as a result of ongoing activities. While it is difficult to accurately predict the consequences of climate change to a particular species or habitat, a range of consequences are expected that are likely to change the status of the species and the condition of their habitats both within and outside of the action area.

The 2022 Sixth Assessment Report reviews key developments since the Fifth Assessment Report (IPCC 2022). The following are the overarching conclusions from the whole of the assessment:

1. The magnitude of observed impacts and projected climate risks indicate the scale of decision-making, funding and investment needed over the next decade if climate resilient development is to be achieved.
2. Climate risks are appearing faster and will get more severe sooner (high confidence). Impacts cascade through natural and human systems, often compounding with the impacts from other human activities. Feasible, integrated mitigation and adaptation solutions can be tailored to specific locations and monitored for their effectiveness while avoiding conflict with sustainable development objectives and managing risks and tradeoffs (high confidence).
3. Available evidence on projected climate risks indicates that opportunities for adaptation to many climate risks will likely become constrained and have reduced effectiveness should 1.5 degree Celsius global

warming be exceeded and that, for many locations on Earth, capacity for adaptation is already significantly limited. The maintenance and recovery of natural and human systems will require the achievement of mitigation targets.

The globally-averaged combined land and ocean surface temperature data, as calculated by a linear trend, show a warming of approximately 1.0°C from 1901 through 2016 (Hayhoe et al. 2018). The *IPCC Special Report on the Impacts of Global Warming* (IPCC 2018) noted that human-induced warming reached temperatures between 0.8 and 1.2°C above pre-industrial levels in 2017, likely increasing between 0.1 and 0.3°C per decade. Warming greater than the global average has already been experienced in many regions and seasons, with most land regions experiencing greater warming than over the ocean (Allen et al. 2018). Global average sea levels are expected to continue to rise by at least several inches in the next 15 years and by 1 to 4 ft (0.3 to 1.2 m) by 2100. Sea level rise will be higher than the global average on the East and Gulf Coasts of the United States (Wuebbles et al. 2017). Climate change has been linked to changing ocean currents as well.

In general, waters in the Mid-Atlantic are warming and are expected to continue to warm. However, waters in the North Atlantic Ocean have warmed more slowly than the global average or slightly cooled. This is because of the Gulf Stream's role in the Atlantic Meridional Overturning Circulation (AMOC). Warm water in the Gulf Stream cools, becomes dense, and sinks, eventually becoming cold, deep waters that travel back equatorward, spilling over features on the ocean floor and mixing with other deep Atlantic waters to form a southward current approximately 1500 m beneath the Gulf Stream (IPCC 2021). Globally averaged surface ocean temperatures are projected to increase by approximately 0.7 °C by 2030 and 1.4 °C by 2060 compared to the 1986-2005 average (IPCC 2014), with increases of closer to 2°C predicted for the geographic area that includes the action area.

Specifically within Virginia, temperatures have risen more than 1.5°F since the beginning of the 20<sup>th</sup> century, and precipitation is trending upward since 1995 and predicted to increase (Runkle et al. 2022). Globally since 1900, sea level has risen about 7-8 inches; however, along the Virginia coast, sea level has risen 17 inches between 1927 and 2020 at Sewells Point (Runkle et al. 2022).

Climate change has the potential to influence species abundance, geographic distribution, migration patterns, and susceptibility to disease and contaminants, as well as the timing of seasonal activities and community composition and structure (Evans and Bjørge 2013; IPCC 2014; MacLeod 2009; McMahon and Hays 2006; Robinson et al. 2009). Though predicting the precise consequences of climate change on highly mobile marine species is difficult (Becker et al. 2018; Silber et al. 2017; Simmonds and Isaac 2007), recent research has indicated a range of consequences already occurring. The loss of habitat because of climate change could be accelerated due to a combination of other environmental and oceanographic changes such as an increase in the frequency of storms and/or changes in prevailing currents (Antonelis et al. 2006; Baker et al. 2006). Furthermore, the effects of climate change on ESA-listed species will not occur independently from other stressors. Rather, the anthropogenic stressors already affecting fitness and survival will be compounded by the anticipated effects of climate change.

In ocean and coastal ecosystems, risk of biodiversity loss ranges between moderate and very high by 1.5°C global warming level and is moderate to very high by 2°C but with more ecosystems at high and very high risk, and increases to high to very high across most ocean and coastal ecosystems by 3°C (depending on ecosystem). Very high extinction risk for endemic species in biodiversity hotspots is projected to at least double from 2% between 1.5°C and 2°C global warming levels and to increase at least tenfold if warming rises from 1.5°C to 3°C (IPCC 2022).

Ocean acidification may cause a variety of species- and ecosystem-level effects in high latitude ecosystems. Species-level effects may include reductions in the calcification rates of numerous planktonic and benthic

species, alteration of physiological processes such as pH buffering, hypercapnia, ion transport, acid-base regulation, mortality, metabolic suppression, inhibited blood-oxygen binding, and reduced fitness and growth (Fabry et al. 2008). Ecosystem effects could include altered species compositions and distributions, trophic dynamics, rates of primary productivity, and carbon and nutrient cycling (Fabry et al. 2008). Additionally, as the ocean becomes more acidic, low frequency sounds (1 to 3 kiloHertz and below) travel farther because the concentrations of certain ions that absorb acoustic waves decrease with decreasing pH (Brewer and Hester 2009).

Changes in the marine ecosystem caused by global climate change (e.g., ocean acidification, salinity, oceanic currents, dissolved oxygen levels, nutrient distribution) could influence the distribution and abundance of lower trophic levels (e.g., phytoplankton, zooplankton, submerged aquatic vegetation, crustaceans, mollusks, forage fish), ultimately affecting primary foraging areas of ESA-listed species including marine mammals, sea turtles, and fish. Marine species ranges are expected to shift as they align their distributions to match their physiological tolerances under changing environmental conditions (Doney et al. 2012). McMahon and Hays (2006) predicted increased ocean temperatures will expand the distribution of leatherback turtles into more northern latitudes. Changes in core habitat area means some species are predicted to experience gains in available core habitat and some are predicted to experience losses (Hazen et al. 2012).

Climate-related changes in important prey species populations are likely to affect predator populations. For example, blue whales, as predators that specialize in eating krill, are likely to change their distribution in response to changes in the distribution of krill (Clapham et al. 1999; Payne et al. 1986; Payne et al. 1990). The distribution, abundance and migration of baleen whales reflects the distribution, abundance and movements of dense prey patches (e.g., copepods, euphausiids or krill, amphipods, shrimp), which have in turn been linked to oceanographic features affected by climate change (Learmonth et al. 2006). Pecl and Jackson (2008) predicted climate change will likely result in squid that hatch out smaller and earlier, undergo faster growth over shorter life-spans, and mature younger at a smaller size. This could have negative consequences for species such as sperm whales, whose diets can be dominated by cephalopods. Changes in plankton distribution, abundance, and composition are closely related to ocean climate, including temperature. Changes in conditions may directly alter where foraging occurs by disrupting conditions in areas typically used by species and can result in shifts to areas not traditionally used that have lower quality or lower abundance of prey. For ESA-listed species that undergo long migrations, if either prey availability or habitat suitability is disrupted by changing ocean temperatures regimes, the timing of migration can change or negatively impact population sustainability (Simmonds and Elliott 2009).

In sea turtles, sex is determined by the ambient sand temperature (during the middle third of incubation) with female offspring produced at higher temperatures and males at lower temperatures within a thermal tolerance range of 25 to 35°C (Ackerman 1997). Increases in global temperature could skew future sex ratios toward higher numbers of females (Patrício et al. 2021). Over time, this can reduce genetic diversity, or even population viability, if males become a small proportion of populations (Hulin et al. 2009). Sea surface temperatures on loggerhead foraging grounds have also been linked to the timing of nesting, with higher temperatures leading to earlier nesting (Mazaris et al. 2009; Schofield et al. 2009). Green sea turtles emerging from nests at cooler temperatures likely absorb more yolk that is converted to body tissue than do hatchlings from warmer nests (Ischer et al. 2009). Impacts on sea turtle nesting from loss of habitat will likely be exacerbated by sea level rise. The loss of leatherback nesting habitat because of climate change could be accelerated due to a combination of other environmental and oceanographic changes such as an increase in the frequency of storms and/or changes in prevailing currents, both of which could lead to increased beach loss via erosion (Antonelis et al. 2006; Baker et al. 2006). These impacts will be exacerbated by sea level rise. This loss of habitat because of climate change could be accelerated due to a combination of other environmental and

oceanographic changes such as an increase in the frequency of storms and/or changes in prevailing currents, both of which could lead to increased beach loss via erosion (Antonelis et al. 2006; Baker et al. 2006).

Information on current effects of global climate change on Atlantic sturgeon is not available. While it is speculated that future climate change may affect sturgeon and that sturgeon may be highly vulnerable to climate change, it is difficult to predict the magnitude and scope of those potential impacts. Atlantic sturgeon could be affected by changes in river ecology resulting from increases in precipitation and changes in water temperature which may affect recruitment and distribution in these rivers. Changes in oceanic conditions could also affect the marine distribution of Atlantic sturgeon or their marine and estuarine prey resources. Rising sea level may result in the salt wedge moving upstream in affected rivers. Atlantic sturgeon spawning occurs in fresh water reaches of rivers because early life stages have little to no tolerance for salinity. Climate change is also predicted to elevate water temperatures and exacerbate nutrient-loading, pollution inputs, and lower DO, all of which are current stressors to the Atlantic sturgeon.

#### **6.4 Fishing Activity in the Action Area**

Commercial and recreational fishing occurs throughout the action area. Commercial fishing in the U.S. The lease area and cable corridor occupies a portion of NMFS statistical area 631. The area that may be transited by vessels from Europe overlap with a number of offshore statistical areas, while transit routes to other ports, including those in New York, the Delaware River, South Carolina and Virginia overlap with a number of other statistical areas (see, <https://www.fisheries.noaa.gov/resource/map/greater-atlantic-region-statistical-areas>). EEZ portion of the action area is authorized by the individual states or by NMFS under the Magnuson-Stevens Fishery Conservation and Management Act. Fisheries that operate pursuant to the MSFCMA have undergone consultation pursuant to section 7 of the ESA. These biological opinions are available online (available at: <https://www.fisheries.noaa.gov/new-england-mid-atlantic/consultations/section-7-biological-opinions-greater-atlantic-region>).

##### **6.4.1 Fishery Interactions and Entanglement**

Given that fisheries occurring in the action area are known to interact with large whales, the past and ongoing risk of entanglement in the action area is considered here. The degree of risk in the future may change in association with fishing practices and accompanying regulations. It is important to note that in nearly all cases, the location where a whale first encountered entangling gear is unknown and the location reported is the location where the entangled whale was first sighted. The risk of entanglement in fishing gear to fin, sei, blue, and sperm whales in the lease area appears to be low given the low interaction rates in the U.S. EEZ as a whole.

We have reviewed the most recent data available on reported entanglements for the ESA-listed whale stocks that occur in the action area (Hayes et al. 2022a; Hayes et al. 2020; Henry et al. 2022). As reported in Hayes et al. (2022a), for the most recent 5-year period of review (2015-2019) in the U.S. Atlantic, the minimum rate of serious injury or mortality resulting from fishery interactions as 5.7/year for right whales, 1.45/year for fin whales, and 0.4 for sei whales. The minimum rate of serious injury or mortality resulting from fishery interaction is zero for blue and sperm whales as reported in the most recent SAR for blue whales and sperm whales in the North Atlantic (Hayes et al. 2020). In all cases, the authors note that this is a minimum estimate of the amount of entanglement and resultant serious injury or mortality. These data represent only known mortalities and serious injuries; more, undocumented mortalities and serious injuries have likely occurred and gone undetected due to the offshore habitats where large whales occur. Hayes et al. (2020) notes that no confirmed fishery-related mortalities or serious injuries of sei whales have been reported in the NMFS Sea Sampling bycatch database and that a review of the records of stranded, floating, or injured sei whales for the period 2015 through 2019 on file at NMFS found 3 records with substantial evidence of fishery interaction

causing serious injury or mortality, which results in the annual serious injury and mortality rate from fishery interactions noted above. Hayes et al. (2020) reports that sperm whales have not been documented as bycatch in the observed U.S. Atlantic commercial fisheries. Hayes et al. (2021) reported gear entanglements of right whales and fin whales along the northwestern Atlantic coast from 2014 to 2018, including both serious injuries and mortalities.

As explained in the Status of the Species section of this Opinion, there is an active UME for NARWs (<https://www.fisheries.noaa.gov/national/marine-life-distress/2017-2021-north-atlantic-right-whale-unusual-mortality-event>). Of the 115 right whales in the UME as of August 15, 2023, 9 mortalities are attributed to entanglement as well as 31 serious injuries and 36 sublethal injuries. Off the coast of Virginia, Henry et al. (2022) documented a fin whale injury (July 2016) and a right whale mortality (January 2018) from entanglement; however, numerous others occurred within the larger action area beyond Virginia.

Given the co-occurrence of fisheries and large whales in the action area, it is assumed that there have been entanglements in the action area in the past and that this risk will persist at some level throughout the life of the project. However, it is important to note that several significant actions have been taken to reduce the risk of entanglement in fisheries that operate in the action area including ongoing implementation of the Atlantic Large Whale Take Reduction Plan. The goal of the ALWTRP is to reduce injuries and deaths of large whales due to incidental entanglement in fishing gear. The ALWTRP is an evolving plan that changes as NMFS learns more about why whales become entangled and how fishing practices might be modified to reduce the risk of entanglement. It has several components including restrictions on where and how gear can be set; research into whale populations and whale behavior, as well as fishing gear interactions and modifications; outreach to inform and collaborate with fishermen and other stakeholders; and a large whale disentanglement program that seeks to safely remove entangling gear from large whales whenever possible. While there have been delays to implementation of some recently developed ALWTRP measures, the risk of entanglement within the action area is expected to decrease over the life of the action due to compliance of state and Federal fisheries with new ALWTRP measures. All states that regulate fisheries in the U.S. portion of the action area codify the ALWTRP measures into their state fishery regulations.

Past directed commercial fisheries contributed to the steady decline in the population abundance of many ESA-listed anadromous fish species, including Atlantic sturgeon. Between 1890 and 1905, Atlantic sturgeon populations were drastically reduced due to overfishing for sale of meat and caviar. Harvest records indicate that fisheries for sturgeon were conducted in every major coastal river along the Atlantic coast at one time, with fishing effort concentrated during spawning migrations (Smith 1985). The sturgeon fishery during the early years (1870 to 1920) was concentrated in the Delaware River and Chesapeake Bay systems. During the 1970s and 1980s, sturgeon fishing efforts shifted to the South Atlantic, which accounted for nearly 80% of total U.S. landings (64 metric tons). NMFS closed the EEZ to Atlantic sturgeon take in 1999. Poaching of Atlantic sturgeon continues and is a potentially significant threat to the species, but the present extent and magnitude of such activity is largely unknown.

Although directed fishing for Atlantic sturgeon is prohibited under the ESA, large numbers are still captured as bycatch in fishing operations targeting other species. The available bycatch data for FMP fisheries indicate that sink gillnets and bottom otter trawl gear pose the greatest risk to Atlantic sturgeon; although, Atlantic sturgeon are also caught by hook and line, fyke nets, pound nets, drift gillnets and crab pots (ASMFC 2017). Atlantic sturgeon are captured as bycatch in trawl and gillnet fisheries. An analysis of the NEFOP/ASM bycatch data from 2000-2015 (ASMFC 2017) found that most trips that encountered Atlantic sturgeon were in depths less than 20 m and water temperatures between 45-60°F. Average mortality in bottom otter trawls was 4% and mortality averaged 30% in gillnets (ASMFC 2017). Incidental capture of Atlantic sturgeon is expected to

continue in the action area at a similar rate over the life of the proposed action, and bycatch is expected to be the primary source of mortality of Atlantic sturgeon in the Atlantic Ocean portion of the action area.

Commercial fisheries bycatch also represents a significant threat to sea turtles throughout the action area, as sea turtles are highly vulnerable to incidental capture in many fisheries gears including gillnets, trawls, and longlines. Finkbeiner et al. (2011) compiled cumulative estimates of sea turtle bycatch across fisheries of the United States between 1990 and 2007, before and after implementation of fisheries-specific bycatch mitigation measures. Pre- and post-regulatory strata were identified for each fishery based on the first year a sea turtle bycatch mitigation strategy was mandated. For the Atlantic region, an annual mean of 345,800 turtle interactions and 70,700 deaths was estimated for the pre-regulatory strata across all fisheries included in this study. By comparison, an annual mean of 137,700 turtle interactions and 4,500 deaths was estimated for the post-regulatory strata.

Leatherback sea turtles are particularly vulnerable to entanglement in vertical lines. Since 2005, 379 leatherbacks have been reported entangled in vertical lines in the Northeast Region. In response to high numbers of leatherback sea turtles found entangled in the vertical lines of fixed gear in the Northeast Region, NMFS established the Northeast Atlantic Coast Sea Turtle Disentanglement Network (STDN). Formally established in 2002, the STDN is an important component of the National Sea Turtle Stranding and Salvage Network. The STDN works to reduce serious injuries and mortalities caused by entanglements and is active throughout the action area responding to reports of entanglements. Where possible, turtles are disentangled and may be brought back to rehabilitation facilities for treatment and recovery. This helps to reduce the rate of death from entanglement. The Southeast STDN provides similar services in the South Atlantic and Gulf of Mexico. Sea turtles are also captured in fisheries operating in the Gulf of Mexico and in offshore areas where pelagic fisheries such as the Atlantic Highly Migratory Species (HMS) fishery occurs. Sea turtles are also vulnerable to interactions with fisheries occurring off the U.S. South Atlantic coast including the Atlantic shrimp trawl fishery. For all fisheries for which there is a fishery management plan (FMP) or for which any Federal action is taken to manage that fishery, the impacts have been evaluated via section 7 consultation. Past consultations have addressed the effects of Federally-permitted fisheries on ESA-listed species, sought to minimize the adverse impacts of the action on ESA-listed species, and, when appropriate, have authorized the incidental taking of these species. Incidental capture and entanglement of sea turtles is expected to continue in the action area at a similar rate over the life of the proposed action. Safe release and disentanglement protocols help to reduce the severity of impacts.

#### **6.4.2 Federally Managed Fisheries**

In the Northwest Atlantic, NMFS Greater Atlantic Regional Office (GARFO) manages Federal fisheries from Maine to Cape Hatteras, North Carolina; however, the management areas for some of these fisheries range from Maine through Virginia, while others extend as far south as Key West, Florida. The NMFS Southeast Regional Office (SERO) manages Federal fisheries from Cape Hatteras, North Carolina to Texas, including Puerto Rico and the U.S. Virgin Islands. Both NMFS regional offices have conducted ESA section 7 consultation on all Federal fisheries authorized under their jurisdiction.

Each of the most recent GARFO and SERO fishery consultations considered adverse effects to ESA-listed species and concluded that the ongoing action was not likely to jeopardize the continued existence of ESA-listed species. Each of these opinions included an ITS exempting a certain amount of lethal or non-lethal take resulting from interactions with the fisheries. Table 16 shows the exempted take from other current section 7 fisheries consultations on the U.S. Atlantic coast.

**Table 16. Exempted take from other current section 7 fisheries consultations on the U.S. Atlantic coast.**

<b>Fishery Management Plan</b>	<b>Date</b>	<b>Loggerhead turtle</b>	<b>Kemp’s ridley turtle</b>	<b>Green turtle</b>	<b>Leatherback turtle</b>	<b>Atlantic sturgeon</b>	<b>Giant manta ray</b>	<b>Oceanic whitetip shark</b>	<b>Scalloped hammer-head shark</b>
American lobster (NMFS 2014)	July 31, 2014	1 (lethal or non-lethal)	0	0	7 (lethal or non-lethal)				
Atlantic sea scallop (NMFS 2021c)	June 17, 2021	Dredge: 1,095 (385 lethal); Trawl: 13 (6 lethal)	Dredge: 28 (5 observed; 11 lethal, 4 observed) Trawl: 2 (1 lethal)	Dredge: 1 (observed; 1 lethal); Trawl: 1 (1 lethal)	Dredge: 1 (observed; 1 lethal); Trawl: 1 (1 lethal)	Dredge and trawl (combined): 5 (1 lethal every 20 years)			
Coastal migratory pelagics (NMFS 2015b)	June 18, 2015, amended 2017	27 over 3 years (7 lethal)	8 over 3 years (2 lethal)	31 over 3 years (9 lethal)*	1 over 3 years (1 lethal)	12 sublethal every 3 years, 0 lethal across all DPSs			
South Atlantic snapper-grouper (NMFS 2016a)	December 1, 2016	629 (208 lethal) over 3 years	180 (59 lethal) over 3 years	111 (42 lethal) over 3 years	6 (5 lethal) over 3 years				
Southeastern U.S. shrimp (NMFS 2021b)	April 26, 2021	72,670 (2,150 lethal) over 5 years	84,495 (8,505 lethal) over 5 years	21,214 (1,700 lethal) over 5 years	130 (5 lethal) over 5 years	Gulf of Maine DPS 2 sublethal, 0 lethal; New York Bight DPS 7 sublethal, 2 lethal; Chesapeake DPS 19 sublethal, 4 lethal; Carolina DPS 66 sublethal,	8,390 captures (0 lethal)		

						15 lethal; S. Atlantic DPS 103 sublethal, 24 lethal			
HMS fisheries, excluding pelagic longline (NMFS 2020b)	May 15, 2020	91 (51 lethal) over 3 years	22 (11 lethal) over 3 years	46 (21 lethal) over 3 years	7 (3 lethal) over 3 years	Gulf of Maine DPS 34 sublethal, 8 lethal; New York Bight DPS 170 sublethal, 36 lethal; Chesapeake DPS 40 sublethal, 9 lethal; Carolina DPS 10 sublethal, 5 lethal; S. Atlantic DPS 75 sublethal, 19 lethal	9 (0 lethal)	6 (3 lethal)	7 (4 lethal)
HMS, pelagic longline (NMFS 2020c)	May 15, 2020	1080 (280 lethal) over 3 years	21 (8 lethal) combined Kemp's ridley, green (includes N. Atlantic and S. Atlantic DPS), hawksbill, or olive ridley over 3 years	996 (275 lethal) over 3 years			366 (6 lethal) over 3 years	1,362 (498 lethal)	576 (249 lethal)

In addition to the values in the table, the Southeastern U.S. shrimp biological opinion (NMFS 2021b) exempted 5 captures (1 lethal) of Gulf sturgeon, and the HMS pelagic longline biological opinion (NMFS 2020c) exempted 3 takes (3 lethal) of sperm whales.



Table 17 shows the estimated average annual turtle interactions in select commercial fishing gears in the Mid-Atlantic and Georges Bank regions. The 2017 Atlantic Sturgeon Benchmark Stock Assessment (ASMFC 2017) estimated that, on average, 1,139 Atlantic sturgeon (295 lethal; 25%) were caught in gillnet fisheries and 1,062 (41 lethal; 4%) were caught in otter trawl fisheries each year from 2000-2015. Atlantic sturgeon bycatch estimates for Northeast gillnet and trawl gear from 2011-2015 (approximately 761 fish per year for gillnets, 777 per year for trawls) are substantially lower than those from 2006-2010 (approximately 1,074 fish per year for gillnets, 1,016 per year for trawls) (ASMFC 2017).

**Table 17. Estimated average annual turtle interactions in select commercial fishing gears in the Mid-Atlantic and Georges Bank regions. Numbers in parentheses are adult equivalents.**

Gear	Years	Area	Estimated Interactions (adult equivalents)	Mortalities (adult equivalents)	Source
Sea Scallop Dredge	2009-2014	Mid-Atlantic	Loggerhead: 22 (2)	9-19* (1-2)	(Murray 2015)
Sink Gillnet	2012-2016	Mid-Atlantic	Loggerhead: 141(3.8) Kemp's ridley: 29 Leatherbacks: 5.4 Unid. hardshell: 22.4	Loggerhead: 111.4 Kemp's ridley: 23 Leatherbacks: 4.2 Unid. hardshell: 17.6	(Murray 2018)
Bottom Trawl	2014-2018	Mid-Atlantic and Georges Bank	Loggerhead: 116.6 (36.4) Kemp's ridley: 9.2 Green: 3.2 Leatherbacks: 5.2	Loggerhead: 54.4 (17.4) Kemp's ridley: 4.6 Green: 1.6 Leatherbacks: 2.6	(Murray 2020)

\*Of these interactions, 9-19 would result in mortality depending on whether loggerheads that interacted with chain mats without being captured (the unobservable but quantifiable interactions) survived.

## 6.5 Vessel Traffic & Interactions

The action area is used by a variety of vessels ranging from small recreational fishing vessels to large commercial cargo ships. Commercial vessel traffic in the action area includes research, tug/barge, liquid tankers, cargo, military and search-and-rescue vessels, and commercial fishing vessels. Recreational vessel traffic includes cruise ships, sailboats, and charter boats.

The open ocean portion of the action area is used primarily by large cargo and tanker vessels as well as some fishing and research vessels, cruise ships, and military vessels. Trans-Atlantic vessel traffic mainly consists of tankers, container ships, and passenger vessels. Vessel traffic along the southern U.S. coast mainly consists of tug and barge, fishing vessels, tankers, container ships, and passenger vessels; military vessels also transit the

area conducting training and operations. Vessels typically travel offshore before entering a traffic separation scheme heading into port. Traffic generally travels in a north to south or south to north direction. Throughout the Mid-Atlantic, commercial vessel traffic is significant throughout the year with a number of major U.S. ports located along the coast. Vessel traffic is heaviest in the nearshore waters, near major ports, in the shipping lanes. Recreational vessel traffic is high throughout these areas but is generally close to shore compared to commercial vessel travel.

### 6.5.1 Vessel Traffic in the Lease Area and Surrounding Waters

Information from the DEIS (BOEM 2022), the Navigational Safety Risk Assessment (NSRA) prepared to support the COP (Anatec Limited 2022), and Port Access Route Study: Approaches to the Chesapeake Bay, VA (USCG 2021a) helps to establish the baseline vessel traffic in the lease areas and surrounding nearby waters. The project area coincides with high traffic shipping areas (Figure 24), located approximately 41.5 nautical miles (77 km) from the Port of Virginia and approximately 33 nautical miles (61 km) east of the U.S. Navy's Little Creek Base (Aschettino et al. 2020; BOEM 2022; Salisbury et al. 2018). Norfolk is the third busiest port on the U.S. Atlantic Coast, and such ports near the WEA and project area result in vessel activity and the associated traffic and noise (Salisbury et al. 2018). Furthermore, coastal Virginia supports both commercial and recreational fisheries, with associated vessel traffic.

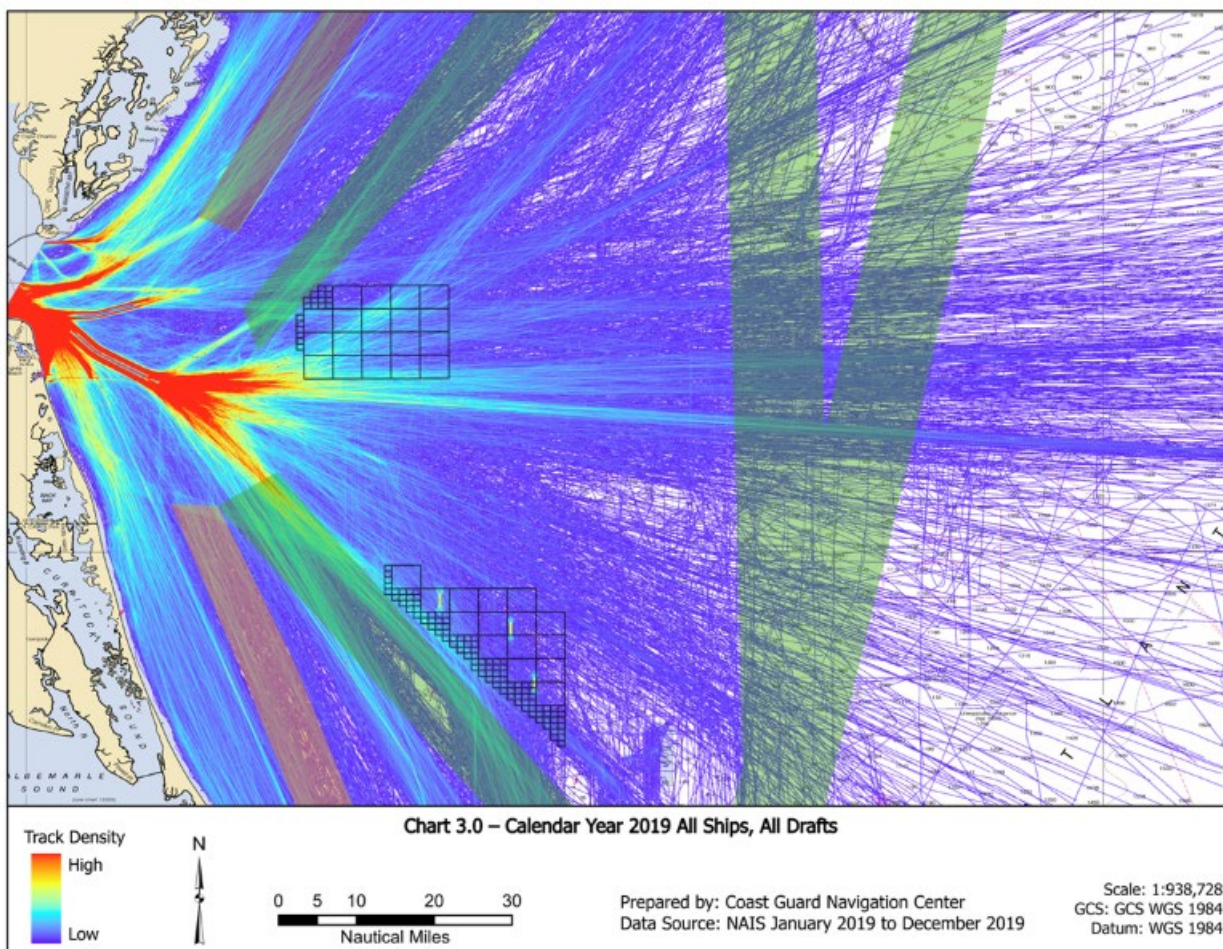

Figure 24. Chesapeake Bay port vessel traffic in calendar year 2019 from the Chesapeake Bay Port Access Route Study AIS Traffic Density Maps (USCG 2021b)

The Chesapeake Bay Traffic Separation Scheme (TSS) regulates vessel traffic in and out of Chesapeake Bay (Anatec Limited 2022). The lease area overlaps with approximately 135 acres (55 hectares; 0.5 km<sup>2</sup>) of the “Chesapeake Bay to Delaware Bay: Eastern Approach Cutoff Fairway,” described in the USCG Port Access Route Study (USCG 2021a), which includes the customary route taken by vessels transiting between the Port of Virginia; the Port of Baltimore, Maryland; the Port of Philadelphia, Pennsylvania; and the Port of Wilmington, Delaware.

The NSRA analyzed navigation and vessel traffic in an area within a 10-nautical mile (18.5 km) buffer of the lease area associated with the CVOW-C project and the CVOW pilot project to cover TSS lanes, staging areas, routes, and areas within 2 nautical miles (3.7 km) of export cable corridors (Anatec Limited 2022). Vessel traffic in the analysis area was busiest during May and September and quietest in December, with an average of approximately 22 to 23 unique vessel transits/day and speed of 10.2 knots (Anatec Limited 2022; BOEM 2022). Vessels during the survey were primarily cargo vessels (75%), followed by military vessels (10%), tankers (6%), recreational vessels (4%), and passenger vessels (2%). Density of vessel traffic was higher along the export cable corridor study area than the overall study area (Anatec Limited 2022).

To comply with the Ship Strike Reduction Rule (50 CFR 224.105), all vessels greater than or equal to 65 ft (19.8 m) in overall length and subject to the jurisdiction of the United States and all vessels greater than or equal to 65 ft in overall length entering or departing a port or place subject to the jurisdiction of the United States must slow to speeds of 10 knots or less in seasonal management areas (SMA). Mid-Atlantic SMAs in the vicinity of the project area include the entrance to the Chesapeake Bay. All vessels 65 ft or longer that transit the SMAs from November 1 – April 30 each year (the period when right whale abundance is greatest) must operate at 10 knots or less. Mandatory speed restrictions of 10 knots or less are required in all of the SMAs along the U.S. East Coast during times when right whales are likely to be present; a number of these SMAs overlap with the portion of the action area that may be used by project vessels. The purpose of this regulation is to reduce the likelihood of deaths and serious injuries to these endangered whales that result from collisions with ships. On August 1, 2022, NMFS published proposed amendments to the North Atlantic vessel strike reduction rule (87 FR 46921). The proposed rule would: (1) modify the spatial and temporal boundaries of current speed restriction areas referred to as Seasonal Management Areas (SMAs), (2) include most vessels greater than or equal to 35 ft (10.7 m) and less than 65 ft (19.8 m) in length in the size class subject to speed restriction, (3) create a Dynamic Speed Zone framework to implement mandatory speed restrictions when whales are known to be present outside active SMAs, and (4) update the speed rule's safety deviation provision. Changes to the speed regulations are proposed to reduce vessel strike risk based on a coast-wide collision mortality risk assessment and updated information on right whale distribution, vessel traffic patterns, and vessel strike mortality and serious injury events. To date, the rule has not been finalized.

Restrictions are in place on how close vessels can approach right whales to reduce vessel-related impacts, including disturbance. NMFS rulemaking (62 FR 6729, February 13, 1997) restricts vessel approach to right whales to a distance of 500 yards. This rule is expected to reduce the potential for vessel collisions and other adverse vessel-related effects in the environmental baseline. The Mandatory Ship Reporting System (MSR) requires ships entering the northeast and southeast MSR boundaries to report the vessel identity, date, time, course, speed, destination, and other relevant information. In return, the vessel receives an automated reply with the most recent right whale sightings or management areas and information on precautionary measures to take while in the vicinity of right whales.

SMAs are supplemented by Dynamic Management Areas (DMAs) that are implemented for 15-day periods in areas in which right whales are sighted outside of SMA boundaries (73 FR 60173; October 10, 2008). DMAs can be designated anywhere along the U.S. eastern seaboard, including the action area, when NOAA aerial

surveys or other reliable sources report aggregations of three or more right whales in a density that indicates the whales are likely to persist in the area. DMAs are put in place for two weeks in an area that encompass an area commensurate to the number of whales present. Mariners are notified of DMAs via email, the internet, Broadcast Notice to Mariners (BNM), NOAA Weather Radio, and the Mandatory Ship Reporting system (MSR). NOAA requests that mariners navigate around these zones or transit through them at 10 knots or less. In 2021, NMFS supplemented the DMA program with a new Slow Zone program, which identifies areas for recommended 10-knot speed reductions based on acoustic detection of right whales. Together, these zones are established around areas where right whales have been recently seen or heard, and the program provides maps and coordinates to vessel operators indicating areas where they have been detected. Compliance with these zones is voluntary.

## **6.5.2 Vessel Impacts to ESA-listed Species**

Within the action area, vessel interactions pose a threat to ESA-listed species. Atlantic sturgeon, sea turtles, and ESA-listed whales are all vulnerable to vessel strike, although the risk factors and areas of concern are different. Vessels have the potential to affect animals through strikes, sound, and disturbance associated with their physical presence. Responses to vessel interactions include interruption of vital behaviors and social groups, separation of mothers and young, and abandonment of resting areas (Boren et al. 2001; Constantine 2001; Mann et al. 2000; Nowacek et al. 2001; Samuels et al. 2000).

Vessel strikes are considered a serious and widespread threat to ESA-listed marine mammals (especially large whales) and sea turtles and are the most well-documented “marine road” interaction with large whales (Pirotta et al. 2019). This threat is increasing as commercial shipping lanes cross important breeding and feeding habitats and as whale populations recover and populate new areas or areas where they were previously extirpated (Swingle et al. 1993; Wiley et al. 1995).

### **6.5.2.1 Vessel Interactions with Whales in the Action Area**

As reported in Hayes et al. (2022b), for the most recent 5-year period of review (2015-2019) in the North Atlantic, the minimum rate of serious injury or mortality resulting from vessel interactions is 2.0/year for right whales, 0.40/year for fin whales, 0.2 for sei whales. No vessel strikes for blue or sperm whales have been documented (Hayes et al. 2020). A review of several sources of available data on serious injury and mortality determinations for sei, fin, sperm, and right whales for 2000-2022 (Hayes et al. 2021; Henry et al. 2022, <https://www.fisheries.noaa.gov/national/marine-life-distress/2017-2023-north-atlantic-right-whale-unusual-mortality-event>) documents numerous injuries and mortalities due to vessel strikes along the Atlantic coast. This includes 2 fin whales documented on the bow of ships (Port Elizabeth, NJ in 2014 and Elberon, NJ in 2020); 3 other fin whale mortalities (off Manasquan, NJ in 2014; Port Newark, NJ in 2017; and Cape Cod Bay in 2018); 4 sei whales documented on the bow of a ships (Newark, NJ in 2016 and 2 in the Hudson River and 1 in the Delaware River discovered when entering port) and 1 that stranded live in the James River and died; 28 vessel strike mortalities to humpback whales; and 12 mortalities (between 2017 to August 2023), 2 serious injuries (2020 and 2021) and 2 cases of morbidity (2020 and 2022) to right whales from vessel strikes. Even for cases where individuals were reported as fresh dead, there is often no information on where the whales were hit. Hayes et al. (2020) reports only four recorded ship strikes of sperm whales.

As vessels become faster and more widespread, an increase in vessel interactions with cetaceans is to be expected. All sizes and types of vessels can hit whales, but most lethal and severe injuries are caused by vessels 80 m (262.5 ft) or longer (Laist et al. 2001). For whales, studies show that the probability of fatal injuries from vessel strikes increases as vessels operate at speeds above 14 knots (26 km per hour; Laist et al. 2001). Evidence suggests that not all whales killed as a result of vessel strike are detected, particularly in offshore

waters, and some detected carcasses are never recovered while those that are recovered may be in advanced stages of decomposition that preclude a definitive cause of death determination (Glass et al. 2010). The vast majority of commercial vessel strike mortalities of cetaceans are likely undetected and unreported, as most are likely never reported. Most animals killed by vessel strike likely end up sinking rather than washing up on shore (Cassoff et al. 2011). Kraus et al. (2005) estimated that 17% of vessel strikes are actually detected. Therefore, it is likely that the number of documented cetacean mortalities related to vessel strikes is much lower than the actual number of mortalities associated with vessel strikes, especially for less buoyant species such as blue, humpback, and fin whales (Rockwood et al. 2017).

#### **6.5.2.2 Vessel Interactions with Sea Turtles in the Action Area**

Propeller and collision injuries from private and commercial vessels are also a significant threat to ESA-listed sea turtles. All sea turtles must surface to breathe and several species are known to bask at the sea surface for long periods. Turtles swimming or feeding at or just beneath the surface of the water are particularly vulnerable to vessel strikes, which can result in serious injury and death (Hazel et al. 2007). Turtles may use auditory cues to react to approaching vessels rather than visual cues, making them more susceptible to strike as vessel speed increases (Hazel et al. 2007). Although sea turtles can move somewhat rapidly, they apparently are not adept at avoiding vessels that are moving at more than 2.6 knots (4 km per hour); most vessels move far faster than this in open water (Hazel and Gyuris 2006; Hazel et al. 2007; Work et al. 2010). Both live and dead sea turtles are often found with deep cuts and fractures indicative of a collision with a vessel hull or propeller (Hazel et al. 2007). Hazel et al. (2007) suggests that green turtles may use auditory clues to react to approaching vessels rather than visual cues, making them more susceptible to vessel strike or vessel speed increases.

Many recovered turtles display injuries that appear to result from interactions with vessels and their associated propulsion systems (Work et al. 2010). This is particularly true in nearshore areas with high vessel traffic along the U.S. Atlantic and Gulf of Mexico coasts. From 1997 to 2005, nearly 15% of all stranded loggerheads in the U.S. Atlantic and Gulf of Mexico were documented as having sustained some type of propeller or collision injury; although it is not known what proportion of these injuries were post or ante-mortem. In one study from Virginia, Barco et al. (2016) found that all 15 dead loggerhead turtles encountered with signs of acute vessel interaction were apparently normal and healthy prior to human-induced mortality.

The incidence of propeller wounds of stranded turtles from the U.S. Atlantic and Gulf of Mexico doubled from about 10% in the late 1980s to about 20% in 2004. Singel et al. (2007) reported a tripling of boat strike injuries in Florida from the 1980's to 2005. Over this time period, in Florida alone over 4,000 (~500 live; ~3500 dead) sea turtle strandings were documented with propeller wounds, which represents 30% of all sea turtle strandings for the state (Singel et al. 2007). These studies suggest that the threat of vessel strikes to sea turtles may be increasing over time as vessel traffic continues to increase in the southeastern U.S.

The Sea Turtle Stranding and Salvage Network reports a large number of vessel interactions (propeller injury) with sea turtles off coastal states such as New Jersey and Florida, where there are high levels of vessel traffic. The Virginia Aquarium & Marine Science Center Strandings Program reported an average of 62.3 sea turtle strandings per year in Virginia waters due to boat strikes from 2009-2014 (Barco et al. 2015). The large majority of these (~ 87%) were dead strandings. By sea turtle species, 73.3% of Virginia vessel strike strandings from 2009-2014 were loggerhead, 20.3% Kemp's ridley, 3.5% green, and 2.9% leatherback (Barco et al. 2015).

#### **6.5.2.3 Vessel Interactions with Sturgeon in the Action Area**

Atlantic sturgeon are struck and killed by vessels in at least some portions of their range. Risk is thought to be highest in areas with reduced opportunity for escape and from vessels operating at a high rate of speed or with

propellers large enough to entrain sturgeon. The factors relevant to determining the risk to sturgeon from vessel strikes are likely related to size and speed of the vessels, navigational clearance (i.e., depth of water and draft of the vessel) in the area where the vessel is operating, and the behavior of sturgeon in the area (e.g., foraging, migrating, etc.). Multiple studies have shown that Atlantic sturgeon are unlikely to move away from vessels or avoid areas with vessel activity (Balazik et al. 2020; DiJohnson 2019; Reine et al. 2014).

In 2012, when Atlantic sturgeon were listed, vessel strikes were considered a primary threat to the New York Bight and Chesapeake Bay DPSs. In particular, sturgeon from the Hudson River spawning population were likely to be impacted by vessel strikes from large commercial vessels in the Delaware and James rivers due to the sturgeon's use of those non-natal estuaries. The ASSRT determined Atlantic sturgeon in the Delaware River are at a moderately high risk of extinction because of vessel strikes, and sturgeon in the James River are at a moderate risk from vessel strikes (ASSRT 2007). Balazik et al. (2012a) estimated up to 80 sturgeon were killed by vessel strike between 2007 and 2010 in these two river systems combined. Brown and Murphy (2010) examined 28 dead Atlantic sturgeon from the Delaware River from 2005 through 2008 and found that 50% of the mortalities resulted from apparent vessel strikes, and 71% of these (10 out of 14) had injuries consistent with being struck by a large vessel. Eight of the fourteen vessel-struck sturgeon were adult-sized fish which, given the time of year the fish were observed, were likely migrating through the river to or from the spawning grounds. Based on evidence of Atlantic sturgeon vessel strikes since the listing, it is now apparent that vessel strikes are also occurring in the Hudson River (NMFS 2022c). Reported vessel strikes represent only minimum counts of the number of Atlantic sturgeon that are actually struck and killed by vessels because the majority of carcasses are either not found or not reported. While the action area does not include upstream riverine areas or sturgeon spawning habitat, ports used for the proposed action are near mouths of rivers used for sturgeon spawning.

## **6.6 Military Operations**

The WEA is located between the North and South areas of U.S. Navy Virginia Capes Range Complex Operations Area, and the offshore export cable route corridor overlaps with the southern area (Anatec Limited 2022; Salisbury et al. 2018). These areas, as well as other U.S. Navy training and testing activities in other areas were subject to consultation: in 2018, NMFS issued a biological opinion (with revised ITS issued in October 2019) on the U.S. Navy Atlantic Fleet's military readiness training and testing activities and the promulgation of regulations for incidental take of marine mammals (NMFS 2018a; NMFS 2019a). The action area includes the Gulf of Mexico and the western Atlantic, with some activities overlapping the action area for the proposed action. Military activities in the area include vessel training operations, aerial overflights, weapons training, submarine activity, and mine detonation exercises. NMFS concluded that the action is not likely to jeopardize the continued existence of any ESA-listed species. The ITS listed takes that are exempted for this action for NARW, blue whale, Rice's whale, fin whale, sei whale, sperm whale, green sea turtle, hawksbill sea turtle, Kemp's ridley sea turtle, loggerhead sea turtle, and leatherback sea turtle from impulsive and non-impulsive acoustic stressors, ship shock trials, and vessel strike (Tables 1 through 3 of NMFS 2019a). The 2018 opinion also anticipates the take of no more than 6 Atlantic sturgeon (up to 1 from the Gulf of Maine DPS, 1 from the New York Bight DPS, 6 from the Chesapeake Bay DPS, 6 from the Carolina DPS, and 1 from the South Atlantic DPS) combined from all DPSs over a 7-year period. The ITS did not specify the amount or extent of take of Atlantic sturgeon, but rather used a surrogate expressed as a distance to reach effects in the water column with injury and sub-injury from acoustic stresses.

## **6.7 Scientific Research**

Numerous scientific surveys, including fisheries and ecosystem surveys carried out by NMFS operate in the action area. Regulations issued to implement section 10(a)(1)(A) of the ESA allow issuance of permits



authorizing take of ESA-listed species for the purposes of scientific research. Prior to the issuance of such a permit, an ESA section 7 consultation must take place. No permit can be issued unless the proposed research is determined to be not likely to jeopardize the continued existence of any listed species. Scientific research permits are issued by NMFS for ESA-listed whales and Atlantic sturgeon; the U.S. Fish and Wildlife Service is the permitting authority for ESA-listed sea turtles. The primary objective of most of these field studies has generally been monitoring populations or gathering data for behavioral and ecological studies. Research on ESA-listed whales, sea turtles, and sturgeon has occurred in the action area in the past and is expected to continue over the life of the proposed action.

In Atlantic waters off the coast of Virginia there are 23 active 10(a)(1)(A) permitted research projects potentially affecting the ESA-listed species discussed in this Opinion: 10 related to whales species, 4 related to sturgeon species, 8 related to sea turtles, and 1 including both sturgeon and turtles. Authorized research on ESA-listed whales includes close vessel and aerial approaches, photographic identification, photogrammetry, photograph/video, thermal imaging, biopsy sampling, fecal sampling, skin sampling, tagging, ultrasound, exposure to acoustic activities, breath sampling, behavioral observations, use of remote vehicles, passive acoustic recording, tracking, and underwater observation. No lethal interactions are anticipated in association with any of the permitted research. Authorized research for ESA-listed sea turtle research includes aerial or vessel survey, approach, capture, handling, restraint, tagging, measurements, photograph/video, carapace marking, biopsy, blood or tissue sampling, ultrasound, imaging, tracking, use of remote vehicles, laparoscopy, epibiota removal, necropsy, and captive experiments. Most authorized take is sublethal with limited amounts of incidental mortality authorized in some permits (i.e., no more than 1 or 2 incidents per permit and only a few individuals overall). Authorized research for Atlantic and shortnose sturgeon includes capture, collection, handling, restraint, internal and external tagging, blood or tissue sampling, gastric lavage, borescope, laparoscopy, ultrasound, egg and sperm collection, use of gill nets, photograph/video, necropsy, and collection of morphometric information. Most authorized take of Atlantic sturgeon for research activities is sublethal with small amounts of incidental mortality authorized (i.e., no more than 1 or 2 incidents per permit and only a few individuals overall).

## **6.8 Marine Debris and Pollution**

Whales, sea turtles, and fish are exposed to a number of other stressors in the action area that are widespread and not unique to the action area, which makes it difficult to determine to what extent these species may be affected by past, present, and future exposure within the action area. These stressors include marine debris and pollution.

Marine debris is an ecological threat that is introduced into the marine environment through ocean dumping, littering, or hydrologic transport of these materials from land-based sources (Gallo et al. 2018). Even natural phenomena, such as tsunamis and continental flooding, can cause large amounts of debris to enter the ocean environment (Watters et al. 2010). Marine debris affects marine habitats and marine life worldwide, primarily by entangling or choking individuals that encounter it, which can lead to injury, infection, reduced mobility, increased susceptibility to predation, decreased feeding ability, fitness consequences, and mortality for ESA-listed species in the action area (Derraik 2002; Gall and Thompson 2015). Marine debris in some form is present in nearly all parts of the world's oceans, including the action area. While the action area is not known to aggregate marine debris as occurs in some parts of the world (e.g., The Great Pacific garbage patch, also described as the Pacific trash vortex, a gyre of marine debris particles in the north central Pacific Ocean), marine debris, including plastics that can be ingested and cause health problems in whales and sea turtles is expected to occur in the action area. Law et al. (2010) presented a time series of plastic content at the surface of the western North Atlantic Ocean and Caribbean Sea from 1986 through 2008. More than 60 of 6,136 surface

plankton net tows collected small, buoyant plastic pieces. Data on marine debris in some locations of the action area is largely lacking; therefore, it is difficult to draw conclusions as to the extent of the problem and its impacts on populations of ESA-listed species in the Atlantic Ocean, but we assume similar effects from marine debris documented within other ocean basins could also occur to species from marine debris.

Listed cetacean species in the action area are known to be negatively impacted by marine debris. Over half of cetacean species (including sperm whales) are known to ingest marine debris (mostly plastic), with up to 31% of individuals in some populations containing marine debris in their guts and being the cause of death for up to 22% of individuals found stranded on shorelines (Baulch and Perry 2014). Entanglement records have clearly been attributed to marine debris for humpback, right, and sperm whales, among others (Baulch and Perry 2012; Laist 1997; NOAA 2014). Given the limited knowledge about the impacts of marine debris on marine mammals, it is difficult to determine the extent of the threats that marine debris poses to marine mammals. However, marine debris is consistently present and has been found in marine mammals in and near the action area. For example, a sei whale stranded and dies in the James River, VA after ingesting a plastic DVD case; this ingestion of plastic debris was the proximate cause of death (Hayes et al. 2021). Butterworth et al. (2012) identified the eastern coast of the U.S. as an entanglement hotspot for humpback and NARWs.

Marine debris is a significant concern for ESA-listed sea turtles in particular because the same processes that draw turtles' buoyant food sources also accumulate large volumes of marine debris, such as plastics and lost fishing gear, in ocean gyres (Carr 1987). Ingestion of plastic debris can block the digestive tract which can cause turtle mortality as well as sublethal effects including dietary dilution, reduced fitness, and absorption of toxic compounds (Laist et al. 1999; Lutcavage et al. 1997). In addition to ingestion risks, sea turtles can also become entangled in marine debris such as fishing nets, monofilament line, and fish-aggregating devices (Laist et al. 1999; Lutcavage et al. 1997; NRC 1990). Schuyler et al. (2016) synthesized the factors influencing debris ingestion by turtles into a global risk model and identified the U.S. east coast (overlapping significantly with the action area) as a region of highest risk globally.

Within the action area, pollution poses a threat to ESA-listed species. Pollution can come in the form of marine debris, pesticides, contaminants, and hydrocarbons. Anthropogenic sources of marine pollution, while difficult to attribute to a specific Federal, state, local, or private action, may affect ESA-listed species in the action area. Sources of pollutants in the action area include atmospheric loading of pollutants (e.g., polychlorinated biphenyls or PCBs); storm water runoff from coastal towns, cities, and villages; runoff into rivers emptying into bays; groundwater discharges; sewage treatment plant effluents; and oil spills. Oil spills, resulting from anthropogenic activities (e.g., commercial vessel traffic/shipping), directly and indirectly affect all components of the marine ecosystem. Degraded water quality from point and nonpoint sources can impact protected species. Run-off can introduce pesticides, herbicides, and other contaminants into the system on which these species depend. Contaminants could degrade habitat if pollution and other factors reduce the food available to marine animals.

## **6.9 Offshore Wind Development**

The action area includes a number of areas that have been leased by BOEM for offshore wind development or that are being considered for lease issuance; additionally, the action area overlaps with the action area identified in a number of biological opinions issued for offshore wind projects. As noted above, in the Environmental Baseline section of a biological opinion, we consider the past and present impacts of all Federal, state, or private activities and the anticipated impacts of all proposed Federal actions that have already undergone section 7 consultation. In the context of offshore wind development, past and present impacts in the action area are limited to the effects of pre-construction surveys to support site characterization, site assessment, and data collection to support the development of Construction and Operations Plans (COPs), as well as ongoing effects



of construction of the South Fork and Vineyard Wind 1 projects. To date, we have completed section 7 consultation to consider the effects of construction, operation, and decommissioning of multiple commercial scale offshore wind project in the action area (Vineyard Wind 1, South Fork Wind, Revolution Wind, Ocean Wind 1, Empire Wind), and to date, construction has only started for South Fork Wind and Vineyard Wind 1. We have also completed ESA section 7 consultation on two smaller scale offshore wind projects that occur in the action area, the Block Island project, and Dominion's Coastal Virginia Offshore Wind Demonstration Project (CVOW pilot project); these projects are in the operations and maintenance phase.

### **6.9.1 Site Assessment, Site Characterization, and Surveys**

A number of geotechnical and geophysical surveys to support wind farm siting have occurred and will continue to occur in the action area. Additionally, data collection buoys have been installed. Effects of these activities on ESA-listed species in the action area are related to potential exposure to noise associated with survey equipment, survey vessels, and habitat impacts. Given the characteristics of the noise associated with survey equipment and the use of best management practices to limit exposure of listed species, including protected species observers, effects of survey noise on listed species have been determined to be extremely unlikely or insignificant. There is no information that indicates that the noise sources used for these surveys has the potential to result in injury, including hearing impairment, or mortality of any ESA-listed species in the action area. Similarly, we have not anticipated any adverse effects to habitats or prey and do not anticipate any ESA-listed species to be struck by survey vessels; risk is reduced by the slow speeds that survey vessels operate at, the use of lookouts, and incorporation of vessel strike avoidance measures.

Surveys to obtain data on fisheries resources have been undertaken in the larger action area to support OSW development. Some gear types used, including gillnet, trawl, and trap/pot, can entangle or capture ESA-listed sea turtles, fish, and whales. Risk can be reduced through avoiding certain times/areas, minimizing soak and tow times, and using gear designed to limit entanglement or reduce the potential for serious injury or mortality.

### **6.9.2 Consideration of Construction, Operation, and Decommissioning of Other OSW Projects**

We have completed ESA consultation for a number of OSW projects to date. Complete information on the assessment of effects of these projects is found in their respective biological opinions (Block Island - NMFS 2015a; CVOW - pilot project NMFS 2016c; South Fork Wind - NMFS 2021a; Vineyard Wind 1 - NMFS 2021e; Ocean Wind 1 - NMFS 2023a; Empire Wind - NMFS 2023b; Revolution Wind - NMFS 2023c). CVOW-C project vessels will transit near the CVOW pilot project. The Block Island, South Fork Wind, Vineyard Wind 1, Ocean Wind 1, Revolution Wind, and Empire Wind lease areas and the geographic areas that may be affected by their project operations are outside of the CVOW-C project area. Also, the geographic extent of noise during construction of these projects will not extend into the CVOW-C lease area. The only portion of those action areas that overlap with the CVOW-C action area is a portion of the vessel transit routes, including vessel transit routes to ports in the U.S. Mid-Atlantic, Canada, and the Gulf of Mexico.

## **7 EFFECTS OF THE ACTION**

Effects of the action are all consequences to listed species or critical habitat that are caused by the proposed action, including the consequences of other activities that are caused by the proposed action. A consequence is caused by the proposed action if it would not occur but for the proposed action and it is reasonably certain to occur. Effects of the action may occur later in time and may include consequences occurring outside the immediate area involved in the action (50 CFR §402.02 and § 402.17).

The primary action is BOEM's proposed approval of the COP with conditions. The ITA proposed by NMFS OPR to authorize incidental take of ESA-listed marine mammals under the MMPA and other permits proposed

to be issued by USACE and EPA are considered effects of the action because they are consequences of BOEM's proposal to approve CVOW-C's COP and they are also Federal actions that may affect ESA-listed species, therefore requiring section 7 consultation.

The purpose of the CVOW-C project is to provide between 2,500 and 3,000 MW of offshore wind generated energy; displacing electricity generated by fossil fuel-powered plants with renewable energy to Virginia and North Carolina consumers. We are not aware of any new actions demanding electricity that would not be developed but for the CVOW-C project specifically. This project supports Virginia's environmental goals by obtaining energy that is cleaner and renewable.

We examine the activities associated with the proposed action and determine what the consequences of the proposed action are to listed species or critical habitat. The effects analysis describes the potential stressors associated with the proposed action that are not likely to adversely affect ESA-listed species or critical habitat. A "not likely to adversely affect" determination is appropriate when an effect is expected to be discountable, insignificant, or completely beneficial. The effects analysis then identifies stressors considered likely to adversely affect ESA-listed species and the probability of exposure to these stressors based on the best scientific and commercial evidence available, and the probable responses of those resources (given probable exposures) based on the available evidence. Take as defined under the ESA means "to harass, harm, pursue, hunt, shoot, wound, kill, trap, capture, or collect, or to attempt to engage in any such conduct." Incidental take is an unintentional, but not unexpected, taking. NMFS interprets "harass" as "Create the likelihood of injury to wildlife by annoying it to such an extent as to significantly disrupt normal behavioral patterns which include, but are not limited to, breeding, feeding, or sheltering."

For any responses that would be expected to reduce an individual's fitness (i.e., growth, survival, annual reproductive success, or lifetime reproductive success), we then consider the risk posed to the viability of the population(s) those individuals comprise and to the ESA-listed species those populations represent in the Integration and Synthesis, section 9. The purpose of this assessment and, ultimately, of this consultation is to determine if it is reasonable to expect the proposed action to have effects on ESA-listed species that could appreciably reduce their likelihood of surviving and recovering in the wild.

Stressors not likely to adversely affect ESA-listed species (discussed in Section 7.2) include the following: goal post pile installation, cofferdam installation, controlled flow evacuation, HRG surveys, vessel and cable installation noise, WTG operational noise, noise impacts to prey, presence of physical structures, changes in oceanographic and hydrological conditions, water quality effects, electromagnetic fields and heat, fishery monitoring surveys, potential shifts in fisheries, and project decommissioning. Multiple of these stressors may cause turbidity and suspended sediments; these effects are described together within the water quality section (Section 7.2.10). Stressors determined likely to adversely affect ESA-listed species (Section 7.3) in the action area include pile driving during WTG and OSS installation and vessel strikes.

## **7.1 Underwater Noise and Acoustic Thresholds**

Anthropogenic sounds cover a broad range of frequencies and sound levels and can have a range of highly variable impacts on marine life, from none or minor to potentially severe behavioral responses, depending on received levels, duration of exposure, behavioral context, and various other factors. Underwater sound from active acoustic sources can have one or more of the following effects: temporary or permanent noise-induced hearing loss, non-auditory physical or physiological effects (including injury and mortality), behavioral disturbance, stress, and masking (Gordon et al. 2003; Gotz et al. 2009; Nowacek et al. 2007; Richardson et al. 1995; Southall et al. 2007a). The degree of effect is intrinsically related to the signal characteristics, received level, distance from the source, and duration of the sound exposure, as well as the hearing range and behavioral

state of the animal. In general, sudden, high level sounds can cause hearing loss, as can longer exposures to lower level sounds.

Threshold shift is the loss of hearing sensitivity at certain frequency ranges (Finneran 2015). It can be permanent (permanent threshold shift: PTS), in which case the loss of hearing sensitivity is not fully recoverable, or temporary (temporary threshold shift: TTS), in which case the animal's hearing threshold would recover over time (Southall et al. 2007a). PTS is an auditory injury, which may vary in degree from minor to significant. Loss of hearing will occur almost exclusively for noise within an animal's hearing range, if the noise threshold is exceeded. Behavioral disturbance may include a variety of effects, including subtle changes in behavior (e.g., minor or brief avoidance of an area or changes in vocalizations), more conspicuous changes in similar behavioral activities, and more sustained and/or potentially severe reactions, such as displacement from or abandonment of high-quality habitat.

BOEM's BA included noise exposure estimates for PTS and behavioral effects; however, the separation of noise exposure estimates above the behavioral threshold that could have potential for TTS (which represents a stronger exposure) was not provided by the action agencies. Therefore, absent additional information, our analyses discuss effects relative to PTS and behavioral thresholds with the assumption that TTS would be similar to behavioral thresholds and we indicate the distance to TTS thresholds because of noise from pile driving in our effects analyses for ESA-listed whales, sea turtles, and fish.

In order to analyze underwater noise and the potential for effects to protected species, NMFS has developed acoustic thresholds using the best available science. To determine which threshold is appropriate, NMFS characterizes sound sources as impulsive or non-impulsive (for hearing threshold shifts) and intermittent or continuous (for behavioral disturbance). Impulsive sound sources produce sounds that are typically transient, brief (less than one second), broadband, and consist of high peak sound pressure with rapid rise time and rapid decay. Impulsive sounds can occur in repetition (e.g., seismic airguns, impact pile driving) or as a single event (e.g., explosives). Non-impulsive sound sources can be continuous or intermittent, and produce sounds that can be broadband, narrowband or tonal, and brief or prolonged. Non-impulsive sources do not have the high peak sound pressure with rapid rise time typical of impulsive sounds. Examples of non-impulsive sources include drilling, vibratory pile driving, and certain active sonars. Continuous sound sources emit sound with a sound pressure level that remains above ambient sound during the entire observation period. Examples of continuous sound sources include drilling and vibratory pile driving. Intermittent sound sources have interrupted levels of low or no sound or bursts of sound separated by silent periods. Typically, intermittent sounds have a more regular (predictable) pattern of bursts of sounds and silent periods (i.e., duty cycle). Examples of intermittent sound sources include scientific sonar, high-resolution geophysical survey equipment (i.e., sub-bottom profilers), and impact pile driving.

### 7.1.1 Whale Acoustic Thresholds

The NMFS 2018 Revision to *Technical Guidance for Assessing the Effects of Anthropogenic Noise on Marine Mammal Hearing*<sup>16</sup> compiles, interprets, and synthesizes scientific literature to produce updated acoustic thresholds to assess how anthropogenic, or human-caused, sound affects the hearing of all marine mammals under NMFS jurisdiction (NOAA 2018). Thresholds are designated by hearing group to acknowledge that not all marine mammal species have identical hearing or susceptibility to noise-induced hearing loss. The NARW, fin and sei whales are grouped with all the other baleen whales in the Low-Frequency Cetaceans hearing group

---

<sup>16</sup> <https://www.fisheries.noaa.gov/national/marine-mammal-protection/marine-mammal-acoustic-technical-guidance>

that has a generalized hearing range<sup>17</sup> of 7 Hz to 35 kHz. The sperm whale is a part of the Mid-Frequency Cetaceans hearing group that has a generalized hearing range of 150 Hz to 160 kHz. The received levels at which individual marine mammals are predicted to experience changes in their hearing sensitivity, PTS or TTS, from impulsive underwater sound are shown in Table 18 and for non-impulsive underwater sound shown in Table 19.

**Table 18. Onset of PTS and TTS for Low and Mid Frequency Cetaceans from Impulsive Sources.**

Hearing Group	Permanent Threshold Shift Onset	Temporary Threshold Shift Onset
Low-Frequency Cetaceans (LF: baleen whales)	$L_{pk,flat}$ : 219 dB $L_{E,LF,24h}$ : 183 dB	$L_{pk,flat}$ : 213 dB $L_{E,LF,24h}$ : 168 dB
Mid-Frequency Cetaceans (MF: sperm whales)	$L_{pk,flat}$ : 230 dB $L_{E,MF,24h}$ : 185 dB	$L_{pk,flat}$ : 224 dB $L_{E,MF,24h}$ : 170 dB

Note: Peak sound pressure level ( $L_{pk,flat}$ ) has a reference value of 1  $\mu$ Pa, and weighted cumulative sound exposure level ( $L_E$ ) has a reference value of 1  $\mu$ Pa<sup>2</sup> s. In this table, thresholds are abbreviated to be more reflective of International Organization for Standardization standards (ISO 2017). The subscript “flat” is being included to indicate peak sound pressure are flat weighted or unweighted within the generalized hearing range of marine mammals (i.e., 7 Hz to 160 kHz). The subscript associated with cumulative sound exposure level thresholds indicates the designated marine mammal auditory weighting function (LF and MF cetaceans) and that the recommended accumulation period is 24 hours. The weighted cumulative sound exposure level thresholds could be exceeded in a multitude of ways (i.e., varying exposure levels and durations, duty cycle).

**Table 19. Onset of PTS and TTS for Low and Mid Frequency Cetaceans from Non-Impulsive Sources.**

Hearing Group	Permanent Threshold Shift Onset	Temporary Threshold Shift Onset
Low-Frequency Cetaceans (LF: baleen whales)	$L_{E,LF,24h}$ : 199 dB	$L_{E,LF,24h}$ : 179 dB
Mid-Frequency Cetaceans (MF: sperm whales)	$L_{E,MF,24h}$ : 198 dB	$L_{E,MF,24h}$ : 178 dB

The thresholds for impulsive sounds are a dual metric, with one threshold based on peak sound pressure level (0-pk SPL) that does not incorporate the duration of exposure, and another based on cumulative sound exposure level (SEL<sub>cum</sub>) that does incorporate exposure duration. Peak sound pressure (also referred to as zero-to-peak sound pressure or 0-pk) is the maximum instantaneous sound pressure measurable in the water at a specified distance from the source. Cumulative SEL represents the total energy accumulated by a receiver over a defined time window or during an event. The cumulative sound exposure criteria incorporate auditory weighting functions, which estimate a species group’s hearing sensitivity, and thus susceptibility to TTS and PTS, over the exposed frequency range, whereas peak sound exposure level criteria do not incorporate any frequency dependent auditory weighting functions.

<sup>17</sup> Represents the generalized hearing range for the entire group as a composite (i.e., all species within the group), where individual species’ hearing ranges are typically not as broad. Generalized hearing range chosen based on approximately 65 dB threshold from normalized composite audiogram, with the exception for lower limits for LF cetaceans Southall, B. L., and coauthors. 2007a. Marine mammal noise and exposure criteria: initial scientific recommendations. *Aquatic Mammals* 33:411-521..

The received levels at which individual marine mammals are predicted to experience the onset of behavioral disturbance are shown in Table 20. The thresholds for behavioral disturbance are applied across all marine mammal hearing groups. The behavioral threshold,  $L_{RMS}$ , is the root mean square sound pressure level. It is not cumulative and does not incorporate any weighting.

**Table 20. Onset of Behavioral Disturbance for Marine Mammals (70 FR 1871)**

Source type	Threshold ( $L_{RMS}$ )
Continuous	120 dB re 1 $\mu$ Pa
Non-explosive impulsive or intermittent	160 dB re 1 $\mu$ Pa

### 7.1.2 Sea Turtle Acoustic Thresholds

In order to evaluate the effects of underwater noise exposure to sea turtles, NMFS relies on acoustic thresholds developed by the U.S. Navy for Phase III of their programmatic approach to evaluating the environmental effects of their military readiness activities (U.S. Navy 2017). The Navy used the best available information on sea turtle hearing and employed the same methodologies to derive thresholds as NMFS for the technical guidance for auditory injury of marine mammals (NOAA 2018).

The received levels at which individual sea turtles are predicted to experience changes in their hearing sensitivity, PTS or TTS, from impulsive underwater sound are shown in Table 21 and for non-impulsive underwater sound shown in Table 22. The received levels at which individual marine mammals are predicted to experience the onset of behavioral disturbance are shown in Table 23.

**Table 21. Onset of PTS and TTS for Sea Turtles from Impulsive Sources.**

Hearing Group	Permanent Threshold Shift	Temporary Threshold Shift
Sea Turtles	$L_{E,p, TU,24h}$ : 204 dB re: 1 $\text{Pa}^2 \cdot \text{s}$ $SEL_{cum}$ $L_{p,0-pk,flat}$ : 232 dB re: 1 $\mu$ Pa SPL (0-pk)	$L_{E,p, TU,24h}$ : 189 dB re: 1 $\mu\text{Pa}^2 \cdot \text{s}$ $SEL_{cum}$ $L_{p,0-pk,flat}$ : 226 dB re: 1 $\mu$ Pa SPL (0-pk)

Note: Peak sound pressure level ( $L_{p,0-pk}$ ) has a reference value of 1  $\mu$ Pa, and weighted cumulative sound exposure level ( $L_{E,p}$ ) has a reference value of 1  $\mu\text{Pa}^2\text{s}$ . In this table, thresholds are abbreviated to be more reflective of International Organization for Standardization standards (ISO 2017). The subscript “flat” is being included to indicate peak sound pressure are flat weighted or unweighted within the generalized hearing range of sea turtles (i.e., below 2 kHz). The subscript associated with cumulative sound exposure level thresholds indicates the designated sea turtle weighting function and that the recommended accumulation period is 24 hours. The weighted cumulative sound exposure level thresholds could be exceeded in a multitude of ways (i.e., varying exposure levels and durations, duty cycle).

**Table 22. Onset of PTS and TTS for Sea Turtles from Non-Impulsive Sources.**

Hearing Group	Permanent Threshold Shift	Temporary Threshold Shift
Sea Turtles	$L_{E,p, TU,24h}$ : 220 dB re: 1 $\text{Pa}^2 \cdot \text{s}$ $SEL_{cum}$	$L_{E,p, TU,24h}$ : 200 dB re: 1 $\mu\text{Pa}^2 \cdot \text{s}$ $SEL_{cum}$

**Table 23. Onset of Behavioral Disturbance for Sea Turtles**

Source type	Threshold
All sources*	$L_{RMS}$ 175 dB

### 7.1.3 Fish Acoustic Thresholds

The Fisheries Hydroacoustic Working Group (FHWG) was formed in 2004 and consists of biologists from NMFS, USFWS, FHWA, USACE, and the California, Washington and Oregon DOTs, supported by national experts on underwater sound producing activities that affect fish and wildlife species of concern. In June 2008, the agencies signed an agreement documenting criteria for assessing physiological effects of impact pile driving on fish. The criteria were developed for the acoustic levels at which physiological effects to fish could be expected. It should be noted that these criteria are for the onset of physiological effects (Stadler and Woodbury 2009), not levels at which fish are necessarily mortally damaged. The criteria in Table 24 were developed to apply to all fish species.

**Table 24. Onset of Physical Injury for Impulsive Sources for Fishes (FHWG 2008)**

<b>Fish Size</b>	<b>Received Level</b>
<b>Fishes &gt; 2 g</b>	<i>L<sub>p</sub></i> ,0-pk,flat: 206 dB <i>L<sub>E,p</sub></i> ,12h: 187 dB
<b>Fishes &lt; 2 g</b>	<i>L<sub>p</sub></i> ,0-pk,flat: 206 dB <i>L<sub>E,p</sub></i> ,12h: 183 dB

Note: For fishes, generally, the accumulation period can be reset to zero after a 12-h period of no pile driving, especially in a river or tidally-influenced waterway when the fish should be moving. Note: The accumulation period for marine mammals and sea turtles is 24-h. Furthermore, NMFS does not have physical injury thresholds for non-impulsive sources, except tactical sonar.

At this time, these criteria represent the best available information on the thresholds at which physiological effects to sturgeon are likely to occur. It is important to note that physiological effects may range from minor injuries from which individuals are anticipated to completely recover with no impact to fitness to significant injuries that will lead to death. The severity of injury is related to the distance from the pile being installed and the duration of exposure. The closer to the source and the greater the duration of the exposure, the higher likelihood of significant injury.

NMFS uses 150 dB re: 1  $\mu$ Pa RMS as a threshold starting point for examining the potential for behavioral responses by individual listed fish to noise. This is supported by information provided in a number of studies (Andersson et al. 2007; Purser and Radford 2011; Wysocki et al. 2007). Responses to temporary exposure of noise of this level is expected to be a range of responses indicating that a fish detects the sound, these can be a brief startle response or a greater response could be some level of avoidance of the area ensonified above 150 dB re: 1  $\mu$ Pa rms. Popper et al. (2014) does not identify a behavioral threshold but notes that the potential for behavioral disturbance decreases with the distance from the source.

## 7.2 Stressors Not Likely to Adversely Affect

We evaluated the potential stressors and determined those discussed in the following subsections may affect, but are not likely to adversely affect ESA-listed resources. Stressors anticipated to have adverse consequences are identified in the next section (Section 7.3). The applicable standard to find that a proposed action is not likely to adversely affect ESA-listed species or designated critical habitat is that all of the effects of the action are expected to be discountable, insignificant, or wholly beneficial, as discussed in Section 4, Species and Critical Habitat Not Likely to be Adversely Affected.

### 7.2.1 Goal Post Pile Installation

As described in the proposed action section of this Opinion, up to 108, 42-in (1.07-m), steel pipe piles would be installed using impact pile driving (an impulsive source) for goal posts to support trenchless installation of the offshore export cable connection to the cable landing location approximately 1,000 m (3,281 ft) offshore of the State Military Reservation in Virginia Beach. Sound fields were modeled at a representative location assuming two posts would be installed per day requiring up to 260 strikes per pile for a total of 130 minutes to install both

piles (Dominion Energy 2023). All goal post piles would be installed between May 1 and October 31 in 2024 and would occur over a total of 24 days for all 108 piles. No noise mitigation will be used during this activity. Goal post pile installation may also result in turbidity and suspended sediment, which is discussed further in Section 7.2.10.

## Whales

The ranges to the PTS and behavioral thresholds for low and mid-frequency cetaceans during impact pile driving of goal post piles are provided in Table 25.

**Table 25. Maximum ranges (m) to PTS and behavioral thresholds for cetaceans during impact pile driving of up to 2 goal post piles per day.**

LFC			MFC		
PTS (Lpk)	PTS (SEL <sub>24h</sub> )	Behavior (SPL)	PTS (Lpk)	PTS (SEL <sub>24h</sub> )	Behavior (SPL)
2	591	1,450	0	21	1,450

LFC = low-frequency cetacean; Lpk = peak sound pressure level in units of dB referenced to 1 micropascal; MFC = mid-frequency cetacean; PTS = permanent threshold shift; SEL<sub>24h</sub> = sound exposure level over 24 hours in units of dB referenced to 1 micropascal squared second; SPL = root-mean-square sound pressure level in units of dB referenced to 1 micropascal. Source: Tetra Tech (2022b)

The number of ESA-listed whales potentially exposed to above threshold noise during installation of the goal post piles was estimated by multiplying the average seasonal density for each species by the harassment zone by the number of days of pile driving (Tetra Tech 2022a). The harassment zone represents the maximum ensonified area calculated as  $\pi r^2$  where r is the threshold range. Densities were obtained from habitat-based spatial density models produced by the Duke University Marine Geospatial Ecology Laboratory (Roberts et al. 2022). The density data were selected based on where they overlapped with the project area, and the maximum densities for each month were averaged by season for the construction period (Table 26). Results of the exposure estimates during goal post pile installation are provided in Table 26. Noise mitigation systems are not commonly applied during nearshore installation activities such as the goal post pile installations and the exposure estimates assume that no noise mitigation is applied during construction (Tetra Tech 2022a).

**Table 26. Estimated number of ESA-listed cetaceans exposed to noise above PTS or behavioral thresholds from goal post impact pile driving.**

Species	Average Seasonal Density (animals/100 km <sup>2</sup> )	PTS and Behavioral Exposures
Fin whale	0.041	0
NARW	0.024	0
Sei whale	0.015	0
Sperm whale	0.001	0

Source: (Tetra Tech 2022a).

km<sup>2</sup> = square kilometers

There are no exposures to noise during installation of the goal post piles expected to occur above the PTS, TTS, or behavioral thresholds for any of the ESA-listed cetaceans. Due to the nearshore location of this activity, approximately 1,000 m (3,281 ft) from the shore, there are low densities of the cetaceans predicted to occur within the area ensonified above the acoustic thresholds. NMFS OPR has reviewed the exposure analysis and is not proposing to authorize any MMPA take from noise during installation of the goal post piles.

The PTS threshold distances for peak sound pressure level are so small that exposure would not be realized for sperm whales (0 m) or baleen whales (2 m) even if they were expected to be in the area. The PTS threshold distances for cumulative sound exposures are still small for sperm whales (21 m) but increase for the baleen whales (591 m). The proposed shutdown for goal post pile driving at any distance for NARW and 1,000 m for the other ESA-listed cetaceans would avoid exposure, especially of the duration needed for a cumulative PTS threshold, even if they were expected to be in the area. The behavioral threshold distance for cetaceans (1,450 m) extends beyond the 1,000-m shutdown but considering these ESA-listed whales are not expected to be using the area, an unlikely exposure is not expected to cause a disturbance that has any meaningful consequence to important behaviors such as breeding, feeding, or migration. The lack of exposure to sound above the acoustic thresholds makes it extremely unlikely that ESA-listed cetaceans will be harmed or harassed from noise during installation of the goal post piles and therefore the effect of that noise is discountable.

### Sea Turtles

Results of the modeling for distances to the PTS and behavioral thresholds for sea turtles during impact pile driving installation of the goal post piles are provided in Table 27. No animal movement or exposure modeling was conducted for this activity.

**Table 27. Maximum ranges (m) to PTS and behavioral thresholds for sea turtles during impact pile driving of up to 2 goal post piles per day.**

PTS (Lpk)	PTS (SEL <sub>24h</sub> )	Behavior (SPL)
0	0	156

Lpk = peak sound pressure level in units of dB referenced to 1 micropascal; SEL<sub>24h</sub> = sound exposure level over 24 hours in units of dB referenced to 1 micropascal squared second; SPL = root-mean-square sound pressure level in units of dB referenced to 1 micropascal  
Source: Dominion Energy 2022

Dominion Energy provided the source levels expected to be produced during impact pile driving of the goal post piles: 210 dB re 1  $\mu$ Pa m, expressed as Lpk, and 183 dB re 1  $\mu$ Pa<sup>2</sup>m<sup>2</sup> s, expressed as SEL (COP Appendix Z; Dominion Energy 2023). These source levels are below both the Lpk and SEL<sub>24h</sub> thresholds for PTS and TTS in Table 21, indicating this activity would not meet or exceed the sound energy sufficient to result in hearing threshold shifts for sea turtles at any distance from the source.

The modeled behavioral threshold may be met or exceeded out to 512 ft (156 m) during installation of the goal post piles. The proposed goal post pile driving shutdown for sea turtles (100 m) would reduce the potential for sea turtles to be exposed to sound above the behavioral threshold, especially sound closer to the source which would be a more intense exposure than sound beyond 100 m. The amount of time the area beyond 100 m would be ensonified is limited to 130 minutes over the course of an installation day, leaving most of the day without that source of sound. The proposed clearance zone for sea turtles prior to goal post pile driving is 1,000 m. Prior to the start of goal post pile driving the clearance zone around the piles to be driven will be monitored by a PSO for at least 30 minutes. Any visual detection of sea turtles within the 1000m clearance zone will trigger a delay in pile installation. The clearance procedures further reduce the already low likelihood of exposure of sea turtles to these noise sources. Limited chances of exposure at lower intensities are not expected to create any



significant behavioral disturbances for sea turtles that would harass the animal enough to result in injurious effects.

The lack of exposure to underwater sound above the sea turtle PTS or TTS thresholds for impulsive sound makes the effects from goal post pile driving discountable for harm to sea turtles. The limited potential for behavioral disturbance makes the effects from goal post pile driving insignificant for harassment to sea turtles.

**Atlantic Sturgeon**

The sound source levels expected to be produced during impact pile driving of the goal post piles, 210 dB re 1  $\mu$ Pa m, expressed as Lpk, and 183 dB re 1  $\mu$ Pa<sup>2</sup>m<sup>2</sup> s, expressed as SEL (COP Appendix Z; Dominion Energy 2023), are below both the Lpk and SEL<sub>12h</sub> thresholds for physical injury to fish weighing greater than two grams in Table 24. Atlantic sturgeon in the action area are expected to weigh greater than two grams indicating this activity would not meet or exceed the sound energy sufficient to result in injury to Atlantic sturgeon at any distance from the source.

Results of the acoustic modeling indicate the maximum range (m) to the fish behavioral threshold (see Section 7.1.3) during installation of up to 2 goal post piles per day using impact pile driving would be 1,450 m (Appendix Z; Dominion Energy 2023). Atlantic sturgeon are most likely to be in the ocean portion of the action area during winter (Kahn 2023, unpublished manuscript), when the impact pile driving of the goal post piles would not be occurring. There is some potential for overlap in May and in October. The limited duration of the goal post pile driving each day of installation (130 minutes for 2 piles), leaves most of the day without that source of sound being able to have any effect on transiting Atlantic sturgeon. The nearshore location limits the intrusion of sound at levels that could cause some level of disturbance into offshore areas used by Atlantic sturgeon for overwinter foraging.

The lack of exposure to underwater sound above the thresholds for physical injury to fish makes the effects from goal post pile driving discountable for harm to Atlantic sturgeon. The limited potential for behavioral disturbance makes the effects from goal post pile driving insignificant for harassment to Atlantic sturgeon.

**7.2.2 Cofferdam Installation**

As described in the proposed action section of this Opinion, up to nine temporary cofferdams may be necessary during cable landfall connection construction activities, which would be installed and removed via vibratory pile driving. Each temporary cofferdam would consist of 30 to 40 steel sheet piles, for a total of 270 to 360 steel sheet piles for all nine cofferdams. Each sheet pile would necessitate approximately 2 to 3 minutes of active vibratory pile drive time for installation, at a maximum installation rate of 20 sheet piles per day (up to 40 - 60 minutes daily). Each cofferdam would take a total of 6 days to install and remove between May 1 and October 31 in 2024. Cofferdam installation may also result in turbidity and suspended sediment, which is discussed further in Section 7.2.10.

**Whales**

The ranges to the PTS and behavioral thresholds for low and mid-frequency cetaceans during cofferdam installation.

**Table 28. Maximum distances (m) to PTS and behavioral thresholds for cetaceans during vibratory pile driving of cofferdams.**

LFC		MFC	
PTS (SEL <sub>24h</sub> )	Behavior (SPL)	PTS (SEL <sub>24h</sub> )	Behavior (SPL)

108	3,097	0	3,097
-----	-------	---	-------

dB = decibel; LFC = low-frequency cetacean; MFC = mid-frequency cetacean; SEL<sub>24h</sub> = sound exposure level over 24 hours in units of dB referenced to 1 micropascal squared second; SPL = root-mean-square sound pressure level in units of dB referenced to 1 micropascal; PTS = permanent threshold shift. Source: Tetra Tech (2022b)

As a result of the small threshold ranges and relatively low densities of large whales likely to be present (see Table 29 below) during installation of the cofferdams, no PTS exposures are expected to occur. The PTS threshold would not be exceeded for MFC at any distance. The range to the PTS threshold for LFC, 354 ft (108 m), may be exceeded but BOEM concluded that PTS is not likely to be realized given the nearshore location of this activity and the proposed mitigation, which we agree is a reasonable determination. The nearshore location greatly reduces the likelihood of these large whale species being in close proximity, as large whales are rarely present in shallow nearshore waters. Vibratory pile driving for the cofferdams would also not occur between May 1 and October 31 to avoid times when NARW occurrence in the project area is more likely. The clearance and shutdown zones for NARW will extend to any distance from the cofferdam and all other LFC species will have a clearance and shutdown zone that extends out to 3,281 ft (1,000 m), which is well beyond the 108-m PTS threshold distance for vibratory pile driving of the cofferdams. The resulting potential for PTS exposures resulting from vibratory pile driving of cofferdams is highly unlikely and, therefore, discountable.

The number of ESA-listed marine mammal species potentially exposed to noises above the behavioral thresholds from vibratory pile driving of cofferdams were estimated using the same methods as those described in the previous section for the goal post piles and are summarized in Table 29, with the average seasonal densities used to estimate the exposures.

**Table 29. Estimated number of ESA-listed cetaceans exposed to noise above behavioral thresholds from vibratory pile driving of cofferdams.**

Species	Average Seasonal Density (animals/100 km <sup>2</sup> )	Behavioral Exposures
Fin whale	0.041	1
NARW	0.024	0
Sei whale	0.015	0
Sperm whale	0.001	0

Km<sup>2</sup> = square kilometers Source: Tetra Tech (2022a).

Exposures to noise above the behavioral threshold were only predicted to occur for a single fin whale; all other species had zero exposures estimated. This is largely due to the low densities of the animals predicted to occur around the cofferdam installation location. The nearshore location greatly reduces the likelihood of a fin whale being in close proximity. The shutdown zone for fin whales is 1,000 m, which does not cover the whole 3,097 m behavioral threshold distance but it will reduce the potential for a fin whale to be exposed to sound above the behavioral threshold, especially sound closer to the source which would be a more intense exposure than sound beyond 1,000 m. The amount of time the area beyond 1000 m would be ensonified is limited to 40-60 minutes over the course of an installation day, leaving most of the day without that source of sound. The proposed clearance zone for fin whales prior to vibratory pile driving of cofferdams is 1,000 m. Any visual detection of fin whales within the 1000 m clearance zone will trigger a delay in the sheet pile installation. The clearance procedures further reduce the likelihood of exposure of fin whales to this noise source. A limited chance of exposure at a lower intensity is not expected to create any significant behavioral disturbances for a fin whale

that would harass the animal enough to result in injurious effects and, therefore, sound from vibratory pile driving of cofferdams above the behavioral threshold for cetaceans would be insignificant.

### Sea Turtles

Results of the modeling for distances to the PTS and behavioral thresholds for sea turtles during vibratory pile driving installation of cofferdams are provided in Table 30.

**Table 30. Maximum distances (m) to PTS and behavioral thresholds for sea turtles during vibratory pile driving of cofferdams.**

PTS (SEL <sub>24h</sub> )	Behavior (SPL)
0	0

PTS = permanent threshold shift; SEL<sub>24h</sub> = sound exposure level over 24 hours in units of dB referenced to 1 micropascal squared second; SPL = root-mean-square sound pressure level in units of dB referenced to 1 micropascal Source: Dominion Energy 2022

The modeling assumed a source level of 195 dB re 1  $\mu\text{Pa}^2\text{m}^2\text{s}$ , expressed as SEL over 1 second, which is below the thresholds for PTS and TTS in Table 22, indicating this activity will not meet or exceed the sound energy sufficient to result in hearing threshold shifts for sea turtles at any distance from the source.

Modeling results show behavioral thresholds are also not likely to be met or exceeded at any range. The source levels in root mean square sound pressure levels were not provided in the modeling information report; so we cannot assume the source level was below threshold, but it is likely low enough because the propagation range to the 175 dB re 1  $\mu\text{Pa}$  threshold resulted in an effective threshold range of 0 m. At that range, no exposure to sound from vibratory pile driving during installation of the temporary cofferdams is expected for sea turtles.

The lack of exposure to sound from vibratory pile driving installation of cofferdams that could be considered to harm or harass sea turtles makes those effects discountable from this activity.

### Atlantic Sturgeon

NMFS does not have physical injury thresholds for non-impulsive sources<sup>18</sup> like vibratory pile driving for Atlantic sturgeon. The result of the underwater noise modeling for the distance to the SPL<sup>19</sup> behavioral threshold for fish during vibratory pile driving installation of cofferdams was 248 m.

As previously mentioned, Atlantic sturgeon are most likely to be in the ocean portion of the action area during winter (Kahn 2023, unpublished manuscript), when the vibratory pile driving of cofferdams would not be occurring. There is some potential for overlap in May and in October. The limited duration of the vibratory pile driving of cofferdams each day of installation (40-60 minutes), leaves most of the day without that source of sound causing any effect on transiting Atlantic sturgeon. The nearshore location limits the intrusion of sound at levels that could cause disturbance into offshore areas used by Atlantic sturgeon for overwinter foraging. The limited potential for behavioral disturbance makes the effects from vibratory pile driving of cofferdams insignificant for Atlantic sturgeon.

### 7.2.3 Controlled Flow Excavation

In the event cofferdams are determined not to be feasible, Dominion Energy proposes to utilize a controlled flow excavation (CFE) tool to excavate a targeted area to expose each Direct Pipe conduit “pipe” for the

<sup>18</sup> Except for tactical sonar.

<sup>19</sup> SPL = root mean-square sound pressure level in units of dB referenced to 1 micropascal.

respective cable pull-ins. If Dominion Energy utilizes the CFE methodology, an estimated total disturbed area of less than 1.0 acre (0.4 Hectares) is expected for the nine (9) punch-out installations.

The CFE uses jets of water to move sand and does not come into contact with the substrate. Given that there is no contact with the substrate and the substrate is not entrained or otherwise removed through the CFE there is not expected to be any risk of impingement, entrainment, capture, or other sources of injury associated with the CFE. As such, effects to listed species from the CFE are extremely unlikely to occur and therefore discountable.

#### 7.2.4 HRG Surveys

CVOW-C plans to conduct HRG survey activities from the time of LOA issuance throughout the construction timeline, including pre-lay surveys prior to construction, as-built surveys during construction, and post-construction surveys. Surveys would occur annually, with durations dependent on the activities occurring in that year (i.e., construction years versus operational years). Equipment planned for use includes multibeam echosounders, single beam depth sounders, sidescan sonar, compressed high-intensity radiated pulse (CHIRPs), parametric sub-bottom profilers, boomers, and sparkers. No air guns are proposed for use. Up to 65 days of surveys are planned in 2024, 249 are planned in 2025, 58 are planned in 2026, and 368 survey days are planned annually in each of 2027 and 2028. No surveys are planned to occur in 2029. These surveys may occur across the entire CVOW-C lease area and export cable routes and may take place at any time of year.

A number of measures to minimize effects to ESA-listed species during HRG operations are included as part of the proposed action. Measures include daytime visual monitoring by PSOs, soft-start procedures, pre-start clearance, and shutdown if ESA-listed animals are observed within the clearance zone. Clearance and shutdown zones that would be implemented are: 1,640-ft (500-m) clearance and shutdown zone for NARW, 1,640-ft (500-m) clearance zone and shutdown zone for all ESA-listed marine mammal species, and 3,280-ft (1,000-m) clearance zone and a 328-ft (100-m) shutdown zone for sea turtles.

Operation of some survey equipment types is not reasonably expected to result in any effects to ESA-listed species in the area. The single beam and multibeam echosounders (MBES), side-scan sonar, and the magnetometer that may be used in these surveys all have operating frequencies >180 kHz and are therefore outside the general hearing range of ESA-listed species that may occur in the survey area. Due to the characteristics of non-impulsive sources (i.e., Ultra-Short BaseLine (USBL), Innomar, and other parametric sub-bottom profilers), these sources have operating characteristics like very narrow beam width that limit acoustic propagation. USBL positioning systems produce extremely small acoustic propagation distances in their typical operating configuration. Parametric sub-bottom profilers (SBP), also called sediment echosounders, generate short, very narrow-beam ( $1^{\circ}$  to  $3.5^{\circ}$ ) signals at high frequencies (generally around 85-100 kHz). The narrow beam width significantly reduces the potential that an individual animal could be exposed to the signal, while the high frequency of operation means that the signal is rapidly attenuated in seawater. All noise producing survey equipment is secured to the survey vessel or towed behind a survey vessel and is only turned on when the vessel is traveling along survey transects; thus, the area ensounded is constantly moving, making survey noise transient and intermittent.

BOEM completed a desktop analysis of nineteen HRG sources in Crocker and Fratantonio (2016) to evaluate the distance to thresholds of concern for listed species. Equipment types or frequency settings that would not be used for the survey purposes by the offshore wind industry were not included in this analysis. To provide the maximum impact scenario for these calculations, the highest power levels and most sensitive frequency setting for each hearing group were used when the equipment had the option for multiple user settings. All sources were analyzed at a tow speed of 2.315 m/s (4.5 knots), which is the expected speed vessels will travel while towing equipment. BOEM has conservatively used the highest power levels for each sound source reported in

Crocker and Fratantonio (2016). The modeling approach used does not consider the tow depth and directionality of the sources; therefore, these are likely overestimates of actual disturbance distances but still within reason. Distances to potential onset of injury and behavioral disturbance thresholds were determined for sea turtles and Atlantic sturgeon, as presented in Table 31 and Table 32 below. Note that for sea turtle PTS distances were calculated for 203 cSEL and 230 dB peak criteria from (U.S. Navy 2017) and Fisheries Hydroacoustic Working Group (2008) for fish. Rows with “NA” indicate not applicable due to the sound source being out of the hearing range for the group. The calculated distance to the 150 dB rms threshold for the Applied Acoustics Dura-Spark is 1,996 m; however, the distances for other equipment in this category is significantly smaller.

**Table 31. Largest PTS Exposure Distances from mobile HRG Sources at Speeds of 4.5 knots – Fish and Sea Turtles**

HRG Source	PTS distance (m)				
	Highest Source Level (dB re 1 µPa)	Sea Turtles		Fish	
<i>Mobile, Impulsive, Intermittent Sources</i>					
		<i>Peak</i>	<i>SEL</i>	<i>Peak</i>	<i>SEL</i>
Boomers, Bubble Guns	176 dB SEL 207 dB RMS 216 PEAK	0	0	3.2	0
Sparkers	188 dB SEL 214 dB RMS 225 PEAK	0	0	9	0
Chirp Sub-Bottom Profilers	193 dB SEL 209 dB RMS 214 PEAK	NA	NA	NA	NA
<i>Mobile, Non-impulsive, Intermittent Sources</i>					
Multi-beam echosounder (100 kHz)	185 dB SEL 224 dB RMS 228 PEAK	NA	NA	NA	NA
Multi-beam echosounder (>200 kHz) (mobile, non-impulsive, intermittent)	182 dB SEL 218 dB RMS 223 PEAK	NA	NA	NA	NA
Side-scan sonar (>200 kHz) (mobile, non-impulsive, intermittent)	184 dB SEL 220 dB RMS 226 PEAK	NA	NA	NA	NA

**Table 32. Largest disturbance distances by equipment type – Sea Turtles and Fish**

HRG Source	Disturbance Distance (m)
------------	--------------------------

	<b>Highest Source Level (dB re 1uPa)</b>	<b>Sea Turtles (175 dB re 1uPa rms)</b>	<b>Fish (150 dB re 1uPa rms)</b>
Boomers, Bubbles Guns	176 dB $L_{E,24h}$ 207 dB $L_{rms}$ 216 $L_{pk}$	40	708
Sparkers	188 dB $L_{E,24h}$ 214 dB $L_{rms}$ 225 $L_{pk}$	90	1,996
Chirp Sub-Bottom Profilers	193 dB $L_{E,24h}$ 209 dB $L_{rms}$ 214 $L_{pk}$	2	2
Multi-beam echosounder (100 kHz)	185 dB $L_{E,24h}$ 224 dB $L_{rms}$ 228 $L_{pk}$	NA	NA
Multi-beam echosounder (>200 kHz)	182 dB $L_{E,24h}$ 218 dB $L_{rms}$ 223 $L_{pk}$	NA	NA
Side-scan sonar (>200 kHz)	184 dB $L_{E,24h}$ 220 dB $L_{rms}$ 226 $L_{pk}$	NA	NA

As described in the Notice of Proposed ITA, modeling was carried out, using the source levels described in Crocker and Fratantonio (2016) to estimate distances to the Level B harassment thresholds for marine mammals (see Table 23 in the Notice of Proposed ITA, reproduced in part as Table 33 below). Note that operating frequencies are above marine mammal hearing thresholds for the multibeam and bathymetric/sidescan sonar.

**Table 33. Summary of Representative HRG Survey Equipment Distances to the Level B Harassment Threshold**

<b>Equipment classification</b>	<b>Survey equipment</b>	<b>Distance (m) to Level B harassment threshold</b>
Multibeam Echosounder	R2Sonics 2026	0.3
Synthetic Aperture Sonar, combined bathymetric/sidescan	Kraken Aquapix	N/A
Sidescan Sonar	Edgetech 4200 dual frequency	N/A
Parametric SBP	Innomar SES-2000 Medium 100	0.7
Non-Parametric SBP	Edgetech 216 CHIRP	10.2
	Edgetech 512 CHIRP	2.4

Medium Penetration SBP	GeoMarine Dual 400 Sparker 800 J	100.0
	Applied Acoustics S-Boom (Triple Plate Boomer 1000 J)	21.9

## Whales

Of the types of HRG equipment operating at frequencies below 180 kHz (within the hearing range of marine mammals), the CHIRP sonar, sparkers, and boomers have the potential to produce sound at levels and distances that could expose marine mammals to sounds above established thresholds (Baker and Howsen 2021). Acoustic modeling in the BA, based on NMFS guidance, resulted in marine mammal LFC PTS thresholds of 0 ft (0 m) for CHIRPs, 0.33 ft (0.1 m) for sparkers, and 19.4 ft (5.9 m) for boomers. Marine mammal MFC thresholds were 0 ft (0 m) for CHIRPs, and 0.7 ft (0.2 m) for boomers. Ranges to the SPL 160 dB re 1  $\mu$ Pa behavioral thresholds were 33.5 ft (10.2 m) for CHIRP, for sparkers, and 72 ft (21.9 m) for boomers. This maximum distance of 328 ft (100 m) from the BA matches the maximum distance to Level B threshold in the MMPA ITA analysis.

In their ITA application, Dominion Energy requested Level B harassment take associated with HRG surveys during the 5-year effective period of the ITA. No Level A harassment was requested, proposed, or anticipated from HRG sources. During this period, a maximum of 1,108 active sound source days (i.e., days in which an acoustic source would be used) of HRG surveys are planned: up to 65 days are anticipated pre-construction, 307 are anticipated to occur during the primary construction years (2025 and 2026), and 736 would occur the post-construction years (368 survey days annually). The ITA proposes the take of 5 NARWs, 5 fin whales, and 3 sei whales due to exposure to noise associated with HRG survey equipment during the five-year effective period of the ITA. NMFS OPR is proposing to authorize this take. As described below, we do not expect that exposure of any ESA-listed whales to noise resulting from HRG surveys will result in any take as defined by the ESA. That is, as explained further below, while we expect that some ESA-listed whales may be exposed to noise above the Level B harassment threshold during HRG surveys, due to the very brief duration of exposure and the minor behavioral reactions, we expect all effects of exposure to HRG survey noise to be insignificant or extremely unlikely to occur. Extensive information on HRG survey noise and potential effects of exposure to ESA-listed whales is provided in NMFS June 29, 2021 programmatic ESA consultation on certain geophysical and geotechnical survey activities (NMFS 2021f). We summarize the relevant conclusions here.

Animals in the survey area during the HRG survey are unlikely to incur any hearing impairment due to the characteristics of the sound sources, considering the source levels and generally very short pulses and duration of the sound. Individuals would have to make a very close approach and also remain very close to vessels operating these sources (<1 m) in order to receive multiple exposures at relatively high levels, as would be necessary to have the potential to result in any hearing impairment. Kremser et al. (2005) noted that the probability of a whale swimming through the area of exposure when a sub-bottom profiler emits a pulse is small—because if the animal was in the area, it would have to pass the transducer at close range in order to be subjected to sound levels that could cause PTS and would likely exhibit avoidance behavior to the area near the transducer rather than swim through at such a close range. Further, the restricted beam shape of many of the HRG survey devices planned for use makes it unlikely that an animal would be exposed more than briefly during the passage of the vessel. The potential for exposure to noise that could result in PTS is even further reduced by the use of PSOs to monitor a clearance zone (1,640 ft [500 m] for ESA-listed whale, including the NARW and unidentified large whale, and 328 ft [100 m] for sperm whales and non-ESA-listed baleen whales)

and to call for a shutdown of equipment operating within the hearing range of ESA-listed whales should a whale be detected within 500 or 100 m. Based on these considerations, it is extremely unlikely that any ESA-listed whale will be exposed to noise that could result in PTS. Therefore, no injury, serious injury, or mortality of any ESA-listed whales is expected to occur as a result of exposure to pile driving noise.

Masking is the obscuring of sounds of interest to an animal by other sounds, typically at similar frequencies. Marine mammals are highly dependent on sound, and their ability to recognize sound signals amid other sounds is important in communication and detection of both predators and prey (Tyack 2000). Although masking is a phenomenon which may occur naturally, the introduction of loud anthropogenic sounds into the marine environment at frequencies important to marine mammals increases the severity and frequency of occurrence of masking. The components of background noise that are similar in frequency to the signal in question primarily determine the degree of masking of that signal. In general, little is known about the degree to which marine mammals rely upon detection of sounds from conspecifics, predators, prey, or other natural sources. In the absence of specific information about the importance of detecting these natural sounds, it is not possible to predict the impact of masking on marine mammals (Richardson et al. 1995). In general, masking effects are expected to be less severe when sounds are transient than when they are continuous. Masking is typically of greater concern for those marine mammals that utilize low-frequency communications, such as baleen whales, because of how far low-frequency sounds propagate. In the Notice of Proposed ITA, NMFS OPR concluded that marine mammal communications would not likely be masked by the sub-bottom HRG survey equipment types planned for use for the types of surveys considered here and the brief period when an individual mammal is likely to be within its beam. Because effects of masking, if any, will be so small that they cannot be meaningfully measured, evaluated, or detected, any effects of masking on ESA-listed whales will be insignificant.

The area ensonified by noise greater than 160 dB re: 1uPa rms will extend no further than 100 m from the source (Table 33). Given that the distance to the 160 dB re: 1 uPa rms threshold is completely encompassed by the required shutdown zone for all ESA-listed whale species except for sperm whales (1,640 ft [500 m] for ESA-listed whale, including the NARW and unidentified large whale, and 328 ft [100 m] for sperm whales and non-ESA-listed baleen whales), we would not expect exposure to such noise.

It is possible that sperm whales will be exposed to potentially disturbing levels of noise during the surveys considered here, as the shutdown zone is less than that for other species. In the case that there is exposure at the edge of the 100-m distance where the distance to acoustic impacts and shutdown zone meet, we have determined that in this case the exposure to noise above the MMPA Level B harassment threshold (160 dB re: 1uPa rms) will result in ESA effects that are insignificant. We expect that the result of this exposure would be, at worst, temporary avoidance of the area with underwater noise louder than this threshold, which is a reaction that is considered to be of low severity and with no lasting biological consequences (e.g., Ellison et al. 2011). The noise source itself will be moving. This means that any co-occurrence between a whale, even if stationary, will be brief and temporary. Given that exposure will be short (no more than a few seconds, given that the noise signals themselves are short and intermittent and because the vessel towing the noise source is moving) and that the reaction to exposure is expected to be limited to changing course and swimming away from the noise source only far/long enough to get out of the ensonified area (100 m or less, depending on the noise source), the effect of this exposure and resulting response will be so small that it will not be able to be meaningfully detected, measured or evaluated and, therefore, is insignificant. Further, the potential for disruption to activities such as feeding (including nursing), resting, and migrating is extremely unlikely given the very brief exposure to any noise (given that the source is traveling and the area ensonified at any given moment is so small). Any brief interruptions of these behaviors are not anticipated to have any lasting effects. Additionally, given the extremely short duration of any behavioral disruption and the very small distance any animal would have to swim to avoid



the noise it is extremely unlikely that the behavioral response would increase the risk of exposure to other threats including vessel strike or entanglement in fisheries gear. Because the effects of these temporary behavioral changes are so minor as to be insignificant, it is not reasonable to expect that, under the NMFS' ESA definition of harassment, they are equivalent to an act that would "create the likelihood of injury to wildlife by annoying it to such an extent as to significantly disrupt normal behavior patterns which include, but are not limited to, breeding, feeding, or sheltering."

### **Sea Turtles**

Although acoustic modeling was not conducted specifically for sea turtles or fish for HRG surveys, it is expected that the injury and behavioral threshold ranges would be smaller than those noted for marine mammals. Sea turtles generally have a lower sensitivity to underwater noise than marine mammals (Finneran et al. 2017; Popper and Hawkins 2014). Analysis for sea turtles in Baker and Howsen (2021), based on Crocker and Fratantonio (2016), estimated the PTS thresholds for sea turtles would not be met or exceeded at any distance for any HRG source type, and the maximum behavioral disturbance threshold range would extend out to 295 ft (90 m) for sparkers. This assessment assumed the maximum power and source settings for each type of equipment, which is not the case for the proposed action, so expected disturbance from the proposed action would be less.

The proposed action includes shutdowns of HRG survey activities when sea turtles are sighted within 328 ft (100 m) of the source. The clearance zone and shutdown zones, therefore, fully cover the area over which both the PTS and behavioral threshold ranges for sea turtles are met or exceeded, reducing the likelihood of sea turtles being exposed. Based on the modeling conducted by Baker and Howsen (2021), PTS thresholds for sea turtles would only be met or exceeded within a few meters (<5 m) of the source. The small area of impact reduces the likelihood that a sea turtle would enter the area during HRG survey operations. Based on clearance and shutdown zones, the transient nature of the surveys and affected areas, as well as the small area exposed to sound levels above the PTS threshold, it is extremely unlikely ESA-listed sea turtles would be exposed to HRG survey noise. Therefore, the effects of survey noise are discountable and not likely to adversely affect ESA-listed sea turtles.

### **Atlantic Sturgeon**

Although acoustic modeling was not conducted specifically for fish for HRG surveys, it is expected that the injury and behavioral threshold ranges would be smaller than those noted for marine mammals. Fish are more sensitive to particle motion than sound pressure, and the swim bladder of Atlantic sturgeon is not directly connected to their hearing, so they are less sensitive to underwater sound than marine mammals (Popper and Hawkins 2014).

Baker and Howsen (2021) estimated the PTS thresholds for fish to extend to 30 ft (9 m) for sparker equipment, and the maximum behavioral disturbance threshold range would extend out to 6,549 ft (1,996 m) for sparkers. However, this assessment assumed the maximum power and source settings were used for each type of equipment, whereas the HRG surveys proposed would be at lower settings. Threshold ranges for boomers were estimated to be 10.5 ft (3.2 m) for the physiological injury threshold and 2,323 ft (708 m) for the behavioral threshold. Threshold ranges for the CHIRPs were estimated to be 0 ft (0 m) for the physiological injury thresholds and 105 ft (32 m) for the behavioral threshold (Baker and Howsen 2021).

CHIRP systems produce frequencies starting around 2 kHz depending on the source, which can be detected by fish but is outside their main sensitivity range. Sparker and boomer HRG equipment to be used in the proposed action would produce noise in frequencies below 1 kHz, which overlaps with hearing sensitivity for fish. Baker

and Howsen (2021) estimate sparker equipment could produce noise exceeding the physiological injury threshold for fish at up to 30 ft (9 m). Soft-start measures, in addition to the transient nature of the sound effects from mobile HRG surveys, result in low likelihood of individual fish being exposed to sufficient sound energy for sufficient duration to cause injury. The possibility for HRG noise to cause injury is therefore discountable.

The range of behavioral thresholds from HRG surveys is approximately 1.2 miles (2 km) (Baker and Howsen 2021). The area where increased underwater noise will be experienced is transient (because the survey vessel towing the equipment is moving), increased underwater noise will only be experienced in a particular area for a short period of time. Given the transient and temporary nature of the increased noise, we expect any effects to behavior to be minor and limited to a temporary disruption of normal behaviors, potential temporary avoidance of the ensonified area and minor additional energy expenditure spent while swimming away from the noisy area. If foraging, resting, or migrations are disrupted, we expect that these behaviors will quickly resume once the survey vessel has left the area (i.e., in seconds to minutes). Therefore, no fish will be displaced from a particular area for more than a few minutes. While the movements of individual fish will be affected by the sound associated with the survey, these effects will be temporary and localized. These fish are not expected to be excluded from any particular area, and there will be only a minimal impact on foraging, migrating, or resting behaviors. Sustained shifts in habitat use, distribution, or foraging success are not expected. Effects to individual fish from brief exposure to potentially disturbing levels of noise are expected to be limited to a brief startle or short displacement and will be so small that they cannot be meaningfully measured, detected, or evaluated; therefore, effects of exposure to survey noise are insignificant. Therefore, HRG surveys are not likely to adversely impact Atlantic sturgeon species.

### **7.2.5 Vessel and Cable Installation Noise**

Vessel noise is considered a continuous noise source that will occur intermittently. Vessels transmit noise through water primarily through propeller cavitation, although other ancillary noises may be produced. The intensity of noise from vessels is roughly related to ship size and speed. Large ships tend to be noisier than small ones, and ships underway with a full load (or towing or pushing a load) produce more noise than unladen vessels. Radiated noise from ships varies depending on the nature, size, and speed of the ship. Vessel noise typically dominates the total ambient sound for frequencies between 20 and 300 Hz. McKenna et al. (2012) determined that container ships produced broadband source levels around 177 to 188 dB re 1  $\mu$ Pa and a typical fishing vessel radiates noise at a source level of about 158 dB re 1  $\mu$ Pa (Mintz and Filadelfo 2011; Richardson et al. 1995; Urick 1983). Noise levels generated by larger construction and installation and O&M would have an approximate  $L_{rms}$  source level of 170 dB re 1  $\mu$ Pa-m (Denes et al. 2020). Smaller construction and installation and O&M vessels, such as CTVs, are expected to have source levels of approximately 160 dB re 1  $\mu$ Pa-m, based on observed noise levels generated by working commercial vessels of similar size and class (Kipple and Gabriele 2003; Takahashi et al. 2019).

Typical large vessel ship-radiated noise is dominated by tonals related to blade and shaft sources at frequencies below about 50 Hz and by broadband components related to cavitation and flow noise at higher frequencies, approximately around the one-third octave band centered at 100 Hz (Mintz and Filadelfo 2011; Richardson et al. 1995; Urick 1983). The acoustic signature produced by a vessel varies based on the type of vessel (e.g., tanker, bulk carrier, tug, container ship) and vessel characteristics (e.g., engine specifications, propeller dimensions and number, length, draft, hull shape, gross tonnage, speed). Bulk carrier noise is predominantly near 100 Hz while container ship and tanker noise is predominantly below 40 Hz (McKenna et al. 2012). Small craft types will emit higher-frequency noise (between 1 kHz and 50 kHz) than larger ships (below 1 kHz). Large shipping vessels and tankers produce lower frequency noise with a primary energy near 40 Hz and underwater SLs for these commercial vessels generally range from 177 to 188 decibels referenced to 1

micropascal at 1 m (dB re 1  $\mu$ Pa m) (McKenna et al. 2012). Smaller vessels typically produce higher frequency sound (1,000 to 5,000 Hz) at SLs of 150 to 180 dB re 1  $\mu$ Pa m (Kipple and Gabriele 2003; Kipple and Gabriele 2004).

As part of various construction related activities, including cable laying and construction material delivery, dynamic positioning thrusters may be utilized to hold vessels in position or move slowly. Sound produced through use of dynamic positioning thrusters is similar to that produced by transiting vessels, and dynamic positioning thrusters are typically operated either in a similarly predictable manner or used for short durations around stationary activities. Dynamically positioned (DP) vessels use thrusters to maneuver and maintain station, and generate substantial underwater noise with apparent SLs ranging from SPL 150 to 180 dB re 1  $\mu$ Pa depending on operations and thruster use (BOEM 2014; McPherson et al. 2016). Acoustic propagation modeling calculations for DP vessel operations were completed by JASCO Applied Sciences, Inc. for two representative locations for pile foundation construction at the South Fork Wind Farm SFWF based on a 107 m DP vessel equipped with six thrusters (Denes et al. 2021). Unweighted root-mean square sound pressure levels (SPLrms) ranged from 166 dB re one  $\mu$ Pa at 50 m from the vessel (CSA 2021). Noise from vessels used for the CVOW-C project are expected to be similar in frequency and source level.

CVOW-C cable burial methods may include jet plow, jet trenching, hydroplow, and mechanical plowing. Noise produced during cable laying includes DP thruster use. Nedwell et al. (2003) reports a sound source level for cable trenching operations in the marine environment of 178 dB re 1 $\mu$ Pa at a distance of 1m from the source. Hale (2018) reports on unpublished information for cable jetting operations indicating a comparable sound source level, concentrated in the frequency range of 1 kHz to 15 kHz and notes that the sounds of cable burial were attributed to cavitation bubbles as the water jets passed through the leading edge of the burial plow. Noise produced during cable installation is dominated by the vessel noise; therefore, we consider these together. Cable installation may also result in turbidity and suspended sediment, which is discussed further in Section 7.2.10.

## Whales

The frequency range for vessel noise (10 to 1000 Hz; MMS 2007) overlaps with the generalized hearing range for blue, sei, fin, and right whales (7 Hz to 35 kHz) and sperm whales (150 Hz to 160 kHz) and would therefore be audible. As described in the BA, larger barges and commissioning vessels would produce sound near 40 Hz from 177 to 200 dB re 1  $\mu$ Pa m, smaller crew transfer vessels would produce higher frequency noise (1,000 to 5,000 Hz) between 150 and 180 dB re 1  $\mu$ Pa m (Kipple and Gabriele 2003; Kipple and Gabriele 2004), and vessels using DP thrusters generate sound ranging from 150 to 180 dB re 1  $\mu$ Pa m (McPherson et al. 2016). Given that the noise associated with the operation of project vessels is below the thresholds that could result in injury, no injury is expected. Noise produced during cable installation is dominated by the vessel noise; therefore, we consider these together.

Marine mammals may experience masking due to vessel noises. For example, right whales were observed to shift the frequency content of their calls upward while reducing the rate of calling in areas of increased anthropogenic noise (Parks et al. 2007a) as well as increasing the amplitude (intensity) of their calls (Parks et al. 2011; Parks et al. 2009). Right whales also had their communication space reduced by up to 84% in the presence of vessels (Clark et al. 2009). Although humpback whales did not change the frequency or duration of their vocalizations in the presence of ship noise, their source levels were lower than expected, potentially indicating some signal masking (Dunlop 2016).

Vessel noise can potentially mask vocalizations and other biologically important sounds (e.g., sounds of prey or predators) that marine mammals may rely on. Potential masking can vary depending on the ambient noise level within the environment, the received level and frequency of the vessel noise, and the received level and

frequency of the sound of biological interest. In the open ocean, ambient noise levels are between about 60 and 80 dB re 1  $\mu$ Pa in the band between 10 Hz and 10 kHz due to a combination of natural (e.g., wind) and anthropogenic sources (Urick 1983), while inshore noise levels, especially around busy ports, can exceed 120 dB re 1  $\mu$ Pa. When the noise level is above the sound of interest, and in a similar frequency band, masking could occur. This analysis assumes that any sound that is above ambient noise levels and within an animal's hearing range may potentially cause masking. However, the degree of masking increases with increasing noise levels; a noise that is just detectable over ambient levels is unlikely to cause any substantial masking.

Vessel noise has the potential to disturb marine mammals and elicit an alerting, avoidance, or other behavioral reaction. These reactions are anticipated to be short-term, likely lasting the amount of time the vessel and the whale are in close proximity (e.g., Magalhaes et al. 2002; Richardson et al. 1995; Watkins 1981), and not consequential to the animals. We also note that we do not anticipate any project vessels to occur within close proximity of any ESA-listed whales; project vessels would maintain separation distances of at least 1,640 ft (500 m) from any sighted ESA-listed whale, including the NARW and unidentified large whales and at least 328 ft (100 m) from sperm whales and non-ESA-listed baleen whales. Vessels will also adhere to the vessel strike avoidance measures, including vessel speed restrictions and use of PSOs, which are expected to ensure no project vessels operate in close proximity to any whales in the action area. Additionally, short-term masking could occur. Masking by passing ships or other sound sources transiting the action area would be short-term and intermittent, unlikely to result in any substantial costs or consequences to individual animals or populations, and therefore insignificant.

Based on the best available information, ESA-listed marine mammals are either not likely to respond to vessel noise or are not likely to measurably respond in ways that would significantly disrupt normal behavior patterns that include, but are not limited to, breeding, feeding or sheltering. Therefore, the effects of vessel noise on ESA-listed marine mammals are insignificant (i.e., so minor that the effect cannot be meaningfully evaluated or detected).

## **Sea Turtles**

The vessels used for the proposed project will produce low-frequency, broadband underwater sound below 1 kHz (for larger vessels), and higher-frequency sound between 1 kHz to 50 kHz (for smaller vessels), although the exact level of sound produced varies by vessel type. Noise produced during cable installation is dominated by the vessel noise; therefore, we consider these together.

ESA-listed turtles could be exposed to a range of vessel noises within their hearing abilities. Depending on the context of exposure, potential responses of green, Kemp's ridley, leatherback, and loggerhead sea turtles to vessel noise disturbance, would include startle responses, avoidance, or other behavioral reactions, and physiological stress responses. Very little research exists on sea turtle responses to vessel noise disturbance. Currently, there is nothing in the available literature specifically aimed at studying and quantifying sea turtle response to vessel noise. However, a study examining vessel strike risk to green sea turtles suggested that sea turtles may habituate to vessel sound and may be more likely to respond to the sight of a vessel rather than the sound of a vessel, although both may play a role in prompting reactions (Hazel et al. 2007). Regardless of the specific stressor associated with vessels to which turtles are responding, they only appear to show responses (avoidance behavior) at approximately 10 m or closer (Hazel et al. 2007).

Therefore, the noise from vessels is not likely to affect sea turtles from further distances, and disturbance may only occur if a sea turtle hears a vessel nearby or sees it as it approaches. These responses appear limited to non-injurious, minor changes in behavior based on the limited information available on sea turtle response to vessel noise.

For these reasons, vessel noise is expected to cause minimal disturbance to sea turtles. If a sea turtle detects a vessel and avoids it or has a stress response from the noise disturbance, these responses are expected to be temporary and only endure while the vessel transits through the area where the sea turtle encountered it. Furthermore, vessels will maintain separation distances of 164 ft (50 m) for sea turtles. Therefore, sea turtle responses to vessel noise disturbance are considered insignificant (i.e., so minor that the effect cannot be meaningfully evaluated), and a sea turtle would be expected to return to normal behaviors and stress levels shortly after the vessel passes by.

### **Atlantic Sturgeon**

The vessels used for the proposed project will produce low-frequency, broadband underwater sound below 1 kHz (for larger vessels), and higher-frequency sound between 1 kHz to 50 kHz (for smaller vessels), although the exact level of sound produced varies by vessel type. Noise produced during cable installation is dominated by the vessel noise; therefore, we consider these together. As described in the BA, vessels using DP thrusters generate sound ranging from 150 to 180 dB re 1  $\mu$ Pa m (McPherson et al. 2016).

In general, information regarding the effects of vessel noise on fish hearing and behaviors is limited. Some TTS has been observed in fishes exposed to elevated background noise and other white noise, a continuous sound source similar to noise produced from vessels. Caged studies on sound pressure sensitive fishes show some TTS after several days or weeks of exposure to increased background sounds, although the hearing loss appeared to recover (e.g., Scholik and Yan 2002; Smith et al. 2006; Smith et al. 2004). Smith et al. (2004) and Smith et al. (2006) exposed goldfish (a fish with hearing specializations, unlike any of the ESA-listed species considered in this Opinion) to noise with a sound pressure level of 170 dB re 1  $\mu$ Pa and found a clear relationship between the amount of TTS and duration of exposure, until maximum hearing loss occurred at about 24 hours of exposure. A short duration (e.g., 10-minute) exposure resulted in 5 dB of TTS, whereas a three-week exposure resulted in a 28 dB TTS that took over two weeks to return to pre-exposure baseline levels (Smith et al. 2004). Recovery times were not measured by researchers for shorter exposure durations, so recovery time for lower levels of TTS was not documented.

Vessel noise may also affect fish behavior by causing them to startle, swim away from an occupied area, change swimming direction and speed, or alter schooling behavior (Engås et al. 1998; Engås et al. 1995; Mitson and Knudsen 2003). Physiological responses have also been documented for fish exposed to increased boat noise. Nichols et al. (2015) demonstrated physiological effects of increased noise (playback of boat noise) on coastal giant kelpfish. The fish exhibited acute stress responses when exposed to intermittent noise, but not to continuous noise. These results indicate variability in the acoustic environment may be more important than the period of noise exposure for inducing stress in fishes. However, other studies have also shown exposure to continuous or chronic vessel noise may elicit stress responses indicated by increased cortisol levels (Scholik and Yan 2001; Wysocki et al. 2006). These experiments demonstrate physiological and behavioral responses to various boat noises that have the potential to affect species' fitness and survival, but may also be influenced by the context and duration of exposure. It is important to note that most of these exposures were continuous, not intermittent, and the fish were unable to avoid the sound source for the duration of the experiment because this was a controlled study. In contrast, wild fish are not hindered from movement away from an irritating sound source, if detected, so are less likely to be subjected to accumulation periods that lead to the onset of hearing damage as indicated in these studies. In other cases, fish may eventually become habituated to the changes in their soundscape and adjust to the ambient and background noises.

All fish species can detect vessel noise due to its low-frequency content and their hearing capabilities. Because of the characteristics of vessel noise (sound levels typically below physical injury thresholds for fish; see Table 24), sound produced from vessels is unlikely to result in direct injury, hearing impairment, or other trauma to

Atlantic sturgeon. In addition, in the near field, fish are able to detect water motion as well as visually locate an oncoming vessel. In these cases, most fishes located in close proximity that detect the vessel either visually, via sound and motion in the water would be capable of avoiding the vessel or move away from the area affected by vessel sound. Thus, fish are more likely to react to vessel noise at close range than to vessel noise emanating from a greater distance away. These reactions may include physiological stress responses, or avoidance behaviors. Auditory masking due to vessel noise can potentially mask biologically important sounds that fish may rely on.

However, impacts from vessel noise would be intermittent, temporary, and localized, and such responses would not be expected to compromise the general health or condition of individual fish from continuous exposures. Instead, the only impacts expected from exposure to project vessel noise for Atlantic sturgeon may include temporary auditory masking, physiological stress, or minor changes in behavior.

Therefore, similar to marine mammals and sea turtles, exposure to vessel noise for fishes could result in short-term behavioral or physiological responses (e.g., avoidance, stress). Vessel noise would only result in brief periods of exposure for fishes and would not be expected to accumulate to the levels that would lead to any injury, hearing impairment or long-term masking of biologically relevant cues. For these reasons, exposure to vessel noise is not expected to significantly disrupt normal behavior patterns (i.e., cause harassment) of Atlantic sturgeon in the action area or harm the species. The effects are so minor that they cannot be meaningfully measured, detected, or evaluated. Therefore, the effects of vessel noise on Atlantic sturgeon are considered insignificant.

## **7.2.6 WTG Operational Noise**

### *Summary of Available Information on WTG Operational Noise*

Once operational, offshore wind turbines produce continuous, non-impulsive underwater noise, primarily in the lower-frequency bands (below 1 kHz; Thomsen et al. 2006a); vibrations from the WTG drivetrain and power generator would be transmitted into the steel monopile foundation generating underwater noise. Most of the currently available information on operational noise from turbines is based on monitoring of existing wind farms in Europe. Although useful for characterizing the general range of WTG operational noise effects, this information is drawn from studies of older generation WTGs that operate with gearboxes and is not necessarily representative of current generation direct-drive systems (Elliott et al. 2019; Tougaard et al. 2020). Studies indicate that the typical noise levels produced by older-generation WTGs with gearboxes range from 110 to 130 dB RMS with 1/3-octave bands in the 12.5- to 500-Hz range, sometimes louder under extreme operating conditions such as higher wind conditions (Betke et al. 2004; Jansen and de Jong 2016; Madsen et al. 2006b; Marmo et al. 2013; Nedwell and Howell 2004; Tougaard et al. 2020). Operational noise increases concurrently with ambient noise (from wind and waves), meaning that noise levels usually remain indistinguishable from background within a short distance from the source under typical operating conditions.

Tougaard et al. (2020) concluded that operational noise from multiple WTGs could elevate noise levels within a few kilometers of large wind farm operations under very low ambient noise conditions. Tougaard et al. (2020) caution that their analysis is based on monitoring data for older generation WTG designs that are not necessarily representative of the noise levels produced by modern direct-drive systems, which are considerably quieter. However, even with these louder systems, Tougaard further stated that the operational noise produced from WTGs is static in nature and is lower than noise produced from passing ships; operational noise levels are likely lower than those ambient levels already present in active shipping lanes, meaning that any operational noise levels would likely only be detected at a very close proximity to the WTG (Thomsen et al. 2006b; Tougaard et al. 2020).

Stober and Thomsen (2021) summarized data on operational noise from offshore wind farms with 0.45 – 6.15 MW turbines based on published measurements and simulations from gray literature then used modeling to predict underwater operational noise levels associated with a theoretical 10 MW turbine. Using generic transmission loss calculations, they then predicted distances to various noise levels including 120 dB re 1uPa RMS. The authors note that there is unresolved uncertainty in their methods because the measurements were carried out at different water depths and using different methods that might have an effect on the recorded sound levels. Given this uncertainty, it is questionable how reliably this model predicts actual underwater noise levels for any operating wind turbines. The authors did not do any in-field measurements to validate their predictions. Additionally, the authors noted that all impact ranges (i.e., the predicted distance to thresholds) come with very high uncertainties.

Using this methodology, they used the sound levels reported for the Block Island Wind Farm turbines in Elliott et al. (2019) and estimated the noise that would be produced by a theoretical 10 MW direct-drive WTG would be above the 120 dB re 1uPa RMS at a distance of up to 1.4 km from the turbine. However, it is important to note that this desktop calculation, using values reported from different wind farms under different conditions, is not based on in situ evaluation of underwater noise of a 10 MW direct-drive turbine. Further, we note that context is critical to the reported noise levels evaluated in this study as well as for any resulting predictions. Without information on soundscape, water depth, sediment type, wind speed, and other factors, it is not possible to determine the reliability of any predictions from the Stober and Thomsen (2021) paper to the CVOW-C project or any other 10 MW or larger turbine. Further, as noted by Tougaard et al. (2020), as the turbines also become higher with larger capacity, the distance from the noise source in the nacelle to the water becomes larger too, and with the mechanical resonances of the tower and foundation likely to change with size as well, it is not straightforward to predict changes to the noise with increasing sizes of the turbines. Therefore, for the reasons provided above, Stober and Thomsen (2021) is not considered the best available scientific information. We also note that Tougaard et al. (2020) and Stober and Thomsen (2021) both note that operational noise is less than shipping noise; this suggests that in areas with consistent vessel traffic, such as the CVOW-C lease area, operational noise may not be detectable above ambient noise.

Elliott et al. (2019) summarized findings from hydroacoustic monitoring of operational noise from the Block Island Wind Farm (BIWF). The BIWF is composed of five GE Haliade 150 6-MW direct-drive WTGs on jacketed foundations located approximately 350 miles (566 km) northeast of the proposed CVOW-C WFA. We note that Tougaard et al. (2020) reported that in situ assessments have not revealed any systematic differences between noise from turbines with different foundation types (Madsen et al. 2006a); thus, the difference in foundation type is not expected to influence underwater noise from operations. Underwater noise monitoring took place from December 20, 2016 – January 7, 2017 and July 15 – November 3, 2017. Elliott et al. (2019) also presents measurements comparing underwater noise associated with operations of the direct-drive turbines at the BIWF to underwater noise reported at wind farms in Europe using older WTGs with gearboxes and conclude that absent the noise from the gears, the direct-drive models are quieter.

The WTGs proposed for CVOW-C will use the newer, direct-drive technology. Elliott et al. (2019) is the only available data on in-situ measurements of underwater noise from operational direct-drive turbines. As such, and given the issues with modeled predictions outlined above, it represents the best available data on operational noise that can be expected from the operation of the CVOW-C turbines. We acknowledge that as the CVOW-C turbines will have a greater capacity (up to 16 MW) than the turbines at Block Island there is some uncertainty in operational noise levels. However, we note that even the papers that predict greater operational noise note that operational noise is less than shipping noise; this suggests that in areas with consistent vessel traffic, such as the CVOW-C lease area, operational noise may not be detectable above ambient noise and, therefore, would be unlikely to result in any behavioral response by any whale, sea turtle, or sturgeon.

Elliott et al. (2019) presented a representative high operational noise scenario at an observed wind speed of 15 m/s (approximately 54 km/h, two to three times the expected average annual wind speed in the CVOW-C lease area. The BIWF WTGs produced frequency weighted instantaneous noise levels of 103 and 79 dB SEL for the LFC (NARW, fin whale, sei whale) and MFC (sperm whale) marine mammal hearing groups in the 10-Hz to 8-kHz frequency band, respectively. Frequency weighted noise levels for the LFC and MFC hearing groups were higher for the 10-Hz to 20-kHz frequency band at 122.5- and 123.3-dB SEL, respectively.

Elliott et al. (2019) also summarizes sound levels sampled over the full survey duration. These averages used data sampled between 10 PM and 10 AM each day to reduce the risk of sound contamination from passing vessels. The loudest noise recorded was 126 dB re 1uPa at 50 m from the turbine when wind speeds exceeded 56 km/h; at wind speeds of 43.2 km/h and less, measured noise did not exceed 120 dB re 1uPa at 50 m from the turbine. As indicated by data from the nearby Cape Henry station maintained by NOAA's National Ocean Service Physical Oceanographic Real Time System Program (PORTS), average monthly wind speeds are around 15 to 30 km/hr (data from 2006 – 2012 ), and instances of wind speeds exceeding 56 km/h in the lease area are expected to be rare, with wind speeds exceeding 40 km/h less than 3-6% of the time across a year (data from 2007 – 2022) (NDBC 2023).

### **Effects of WTG Operation**

Many of the published measurements of underwater noise levels produced by operating WTGs range from older geared WTGs and are not expected to be representative of newer direct-drive WTGs, like those that will be installed for the CVOW-C project. Elliott et al. (2019) reports underwater noise monitoring at the BIWF, which has direct-drive GE Haliade 150-6 MW turbines; this is the best available data for estimating operational noise of the CVOW-C turbines.

In considering the potential effects of operational noise on ESA-listed species we consider the expected noise levels from the operational turbines and the ambient noise (i.e., background noise that exists without the operating turbines) in the lease area. Ambient noise is a relevant factor because if the operational noise is not louder than ambient noise we would not expect an animal to react to it.

Ambient noise includes the combination of biological, environmental, and anthropogenic sounds occurring within a particular region. In temperate marine environments including the WDA, major contributors to the overall acoustic ambient noise environment include the combination of surface wave action (generated by wind), weather events such as rain, lightning, marine organisms, and anthropogenic sound sources such as ships. Salisbury et al. 2018 monitored ambient noise off the coast of Virginia in consideration of the hearing frequencies of a number of marine mammal species. In the right whale frequency band (71-224 Hz), ambient noise exceeded 110 dB 50% of the time and 115 dB 14% of the time. Noise levels in the fin whale frequency band (18-28 Hz) were lower than the other whale species, with noise levels exceeding 100 dB 50% of the time.

Elliott et al. (2019) notes that the direct-drive turbines measured at BIWF generated operational noise above background sound levels at the measurement location of 50 m (164 ft) from the foundation. The authors also conclude that even in quiet conditions (i.e., minimal wind or weather noise, no transiting vessels nearby), operational noise at any frequency would be below background levels within 0.6 miles (1 km) of the foundation. This information suggests that in quiet conditions, an animal located within 1 km of the foundation may be able to detect operational noise above ambient noise conditions. However, given the typical ambient noise in the WDA, we expect these instances of quiet to be rare. Regardless, detection of the noise does not mean that there would be measurable effects to the individual.



Elliott et al. (2019) conclude that based on monitoring of underwater noise at the Block Island site, under worst-case assumptions, no risk of temporary or permanent hearing damage (PTS or TTS) could be projected even if a whale or sea turtle remained in the water at 50 m (164 ft) from the turbine for a full 24-hour period. As such, we do not expect any PTS, TTS, or other potential injury to result from even extended exposure to the operating WTGs. The loudest noise recorded by Elliott et al. (2019) was 126 dB re 1uPa at 50 m from the turbine when wind speeds exceeded 56 km/h; at wind speeds of 43.2 km/h and less, measured noise did not exceed 120 dB re 1uPa at 50 m from the turbine (Elliott et al. 2019). As noted above, based on wind speed records from the Cape Henry buoy (2007 – 2022), instances of wind speeds exceeding 56 km/h in the lease area are expected to be rare, with wind speeds exceeding 43.2 km/h about 4 – 5% of the time across a year and wind speeds exceeding 56 km/h occurring even less frequently.

Given the conditions necessary to result in noise above 120 dB re 1uPa only occur 0-6% of the time on an annual basis, and that in such windy conditions ambient noise is also increased, we do not anticipate the underwater noise associated with the operations noise of the direct-drive WTGs to result in avoidance of an area any larger than 50m from the WTG foundation. As such, even if ESA-listed marine mammals avoided the area with noise above ambient, any effects would be so small that they could not be meaningfully measured, detected, or evaluated, and are therefore insignificant.

We recognize that the data from Elliott et al. (2019) represents WTGs that are of a smaller capacity than those proposed for use at CVOW-C. We also recognize the literature that has predicted larger sound fields for larger turbines. However, we also note that Tougaard et al. (2020) and Stober and Thomsen (2021) both indicate that operational noise is less than shipping noise; this suggests that in areas with consistent vessel traffic, such as the CVOW-C lease area, operational noise is not expected to be detectable above ambient noise at a distance more than 50 m from the foundation. Additionally, while there are no studies documenting distribution of large whales in an area before and after construction of a wind farm, data from other marine mammals (harbor porpoise) indicates that any reduction in abundance in the wind farm area that occurred during the construction period resolves and that harbor porpoise are as abundant in the wind farm area during project operations as they were before. This supports our determination that effects of operational noise are likely to be insignificant for ESA-listed whale species.

Elliott et al. (2019) conclude that based on monitoring of underwater noise at the Block Island site, under worst-case assumptions, no risk of temporary or permanent hearing damage (PTS or TTS) for sea turtles could be projected even if an animal remained in the water at 50 m (164 ft) from the turbine for a full 24-hour period. As underwater noise associated with the operation of the WTGs is below the thresholds for considering behavioral disturbance, and considering that there is no potential for exposure to noise above the peak or cumulative PTS or TTS thresholds, effects to sea turtles exposed to noise associated with the operating turbines are extremely unlikely to occur and are therefore discountable.

Elliott et al. (2019) note that based on monitoring of underwater noise at the Block Island site, the noise levels identified in the vicinity of the turbine are far below any numerical criteria for adverse effects on fish. As underwater noise associated with the operation of the WTGs is expected to be below the thresholds for injury or behavioral disturbance for Atlantic sturgeon, we do not expect any impacts to any Atlantic sturgeon due to noise associated with the operating turbines. Additionally, we note that many studies of fish resources within operating wind farms, including the Block Island Wind Farm, and wind farms in Europe with the older, louder geared turbines report localized increases in fish abundance during operations (due to the reef effect; e.g., Methratta and Dardick 2019; Stenberg et al. 2015; Wilber et al. 2022). This data supports the conclusion that operational noise is not likely to result in the displacement or disturbance of Atlantic sturgeon and any effects are therefore insignificant.

Similarly, we expect that any effects of operational noise on the prey of ESA-listed species to be extremely unlikely or so small that they cannot be meaningfully measured, detected, or evaluated and thus insignificant. As described above, many of the published measurements of underwater noise levels produced by operating WTGs are from older geared WTGs and are not expected to be representative of newer direct-drive WTGs, like those that will be installed for the CVOW-C project. Elliott et al. (2019) note that based on monitoring of underwater noise at the Block Island site, the noise levels identified in the vicinity of the turbine are far below any numerical criteria for adverse effects on fish. As underwater noise associated with the operation of the WTGs is expected to be below the thresholds for injury or behavioral disturbance for fish species, we do not expect any impacts to any fish species due to noise associated with the operating turbines. There is no information to indicate that operational noise will affect krill, copepods, or other zooplankton. Additionally, many studies of fish and benthic resources within operating wind farms, including those with the older, louder geared turbines report localized increases in fish and benthic invertebrate abundance during operations (due to the reef effect; e.g., Methratta and Dardick 2019; Stenberg et al. 2015; Wilber et al. 2022). This data supports the conclusion that operational noise is not likely to result in the displacement or disturbance of prey; therefore, effects to ESA-listed whales, sea turtles, and fish via prey disturbance would be insignificant.

### 7.2.7 Noise Impacts to Prey

The ESA-listed whales, sea turtles and Atlantic sturgeon in the WDA forage in varying frequencies and intensities on a range of prey from small fish to wide variety of invertebrates like zooplankton, including copepods and krill, or benthic arthropods, mollusks and annelids. Green sea turtles have more of an emphasis on seagrass and algae in their diets which is found in more shallow embayments and lagoons which are unlikely areas to be affected from project noise.

Generally, there is very little information available on the effects of underwater noise on many prey species. Effects to fish, such as schooling fish preyed upon by whales or species preyed upon by sea turtles are likely to be similar to the effects determined using criteria for ESA-listed fish (Section 7.1.3). Squid are another important prey resource for ESA-listed whales and sea turtles that may also school like prey fish species. Prey fish and squid species could be relatively abundant in the project area at some point in time which could overlap when underwater noise from the project could be highest (e.g., during pile driving of WTG and OSS foundations, see Section 7.3.1), which creates the potential for injurious effects to some of those fishes and squid if they happen to be close to the noise source when it occurs. The use of a soft-start to ramp up the noise from foundation pile driving should help to avoid these prey species being in close proximity when the full force is being used and greatest sound is produced. If any prey fish or squid do experience injurious effects it is likely to be a small fraction in close proximity to pile driving and not expected to affect the abundance or distribution of prey fish or squid in any substantial way and not removing any significant prey resources to the ESA-listed species in that forage in the area.

Most benthic invertebrates have limited mobility or move relatively slowly as compared to the prey fish species and hence may have less ability to move away from adverse noise sources. As such, there may be some small reductions in benthic invertebrate prey. However, these reductions are expected to be limited to the areas immediately surrounding the piles being installed and not expected to affect the abundance or distribution of benthic invertebrate prey in any substantial way and not remove any significant prey resources to the ESA-listed species in that forage in the area.

We are not aware of information on the effects of pile driving noise, which is the largest source of noise for the project, exposure to krill, copepods, or other zooplankton. McCauley et al. (2017) documented mortality of juvenile krill exposed to seismic airguns but that is not proposed for the CVOW-C project. We are not aware of any evidence that any other noise sources considered in this Opinion are likely to result in the mortality of

zooplankton. If any zooplankton prey do experience injurious effects it is likely to be a small fraction in close proximity to pile driving and not expected to affect the abundance or distribution of zooplankton prey in any substantial way and not removing any significant prey resources to the ESA-listed cetaceans that may forage in the area. Therefore, effects to ESA-listed species via noise impacts to their prey would be insignificant.

### **7.2.8 Presence of Physical Structures**

CVOW-C would comprise 202 potential WTG foundation sites (likely scenario of 176 WTGs installed) laid out in an offset grid-like pattern with spacing of 0.75 to 0.93 nautical miles between turbines. The physical presence of structures in the water column has the potential to disrupt the movement of listed species but also serve as an attractant for prey resources and subsequently listed species. Structures may also provide habitat for some marine species, in the form of refuge habitat and/or by creating a reef effect. The foundations and generation of wind energy may affect the in-water and in-air conditions, which can result in changes to ecological conditions in the marine environment. Here, we consider the best available data that is currently available to address the potential effects on ESA-listed species from the CVOW-C project.

#### **Structure Presence**

The only wind turbines currently in operation in U.S. waters are the 5 WTGs that make up the Block Island Wind Farm and the 2 WTGs that are part of the Coastal Virginia Offshore Wind pilot project. We have not identified any reports or publications that have examined or documented any changes in listed species distribution or abundance at the Block Island or Virginia wind projects and have no information to indicate that the presence of these WTGs has resulted in any change in distribution of any ESA-listed species. It is also not clear whether any monitoring results from such small wind farms may be used to predict responses to the larger scale project currently under consideration here.

Consistent with information from other coastal areas that are not aggregation areas, we generally expect individual Atlantic sturgeon to be present in the WFA for short periods of time (Ingram et al. 2019b; Rothermel et al. 2020). Because Atlantic sturgeon carry out portions of their life history in rivers, they are frequently exposed to structures in the water such as bridge piers and pilings. There is ample evidence demonstrating that sturgeon routinely swim around and past large and small structures in waterways, often placed significantly closer together than even the minimum distance of the closest WTGs. As such, we do not anticipate that the presence of the WTGs or the OSS will measurably affect the distribution of Atlantic sturgeon in the action area or their ability to move through the action area and thus, would be insignificant.

Given their distribution largely in the open ocean, whales and sea turtles may rarely encounter large fixed structures in the water column such as the turbine foundations; thus, there is little information to evaluate the effects that these structures will have on the use of the area by these species. Sea turtles are often sighted around oil and gas platforms and fishing piers in the Gulf of Mexico which demonstrates they do not have an aversion to structures and may utilize them to forage or rest (Lohofener et al. 1990; Rudloe and Rudloe 2005). Given the monopiles' large size (31 ft [9.5 m] diameter) and presence above and below water, we expect that whales and sea turtles will be able to visually detect the structures and, as a result, we do not expect whales or sea turtles to collide with the stationary foundations. Listed whales are the largest species that may encounter the foundations in the water column. Of the listed whales, blue whales are the largest species at up to 90 ft. Based on the spacing of the foundations (1 x 1 nm grid) relative to the sizes of the listed species that may be present in the WFA, we do not anticipate that the foundations would create a barrier or restrict the ability of any listed species to move through the area freely.

While there is currently no before/after data for any of the ESA-listed species that occur in the action area in the context of wind farm development, data is available for monitoring of harbor porpoises before, during, and after construction of three offshore wind projects in Europe. We consider that data here.

Horns Rev 1 in the North Sea consists of 80 WTGs laid out as an oblique rectangle of 5 km x 3.8 km (8 horizontal and 10 vertical rows). The distance between turbines is 560 m in both directions. The project was installed in 2002 (Tougaard et al. 2006). The turbines used at the Horns Rev 1 project are older geared WTGs and not more modern direct-drive turbines, which are quieter (Elliott et al. 2019; Tougaard et al. 2020). The Horns Rev 1 project had significantly fewer foundations compared to the CVOW-C project (80 foundations compared to 202 potential foundation), and turbine spacing is significantly closer together (0.27 nm [0.5 km] compared to at least 0.75 nm [1.39 km]). Pre-construction baseline data was collected with acoustic recorders and with ship surveys beginning in 1999; post-construction acoustic and ship surveys continued until the spring of 2006. In total, there were seven years of visual/ship surveys and five years of acoustic data. Both sets of data indicate a weak negative effect on harbor porpoise abundance and activity during construction, which has been tied to localized avoidance behavior during pile driving, and no effects on activity or abundance linked to the operating wind farm (Tougaard et al. 2006).

Teilmann et al. (2007) reports on continuous acoustic harbor porpoise monitoring at the Nysted wind project (Baltic Sea) before, during, and after construction. The results show that echolocation activity significantly declined inside Nysted Offshore Wind Farm since the pre-construction baseline during and immediately after construction. Teilmann and Carstensen (2012) update the dataset to indicate that echolocation activity continued to increase as time went by after operations began. Thompson et al. (2010) reported similar results for the Beatrice Demonstrator Project, where localized (1-2 km) responses of harbor porpoises were found through PAM, but no long-term changes were found. Scheidat et al. (2011) reported results of acoustic monitoring of harbor porpoise activity for one year prior to construction and for two years during operation of the Dutch offshore wind farm Egmond aan Zee. The results show an overall increase in acoustic activity from baseline to operation, which the authors note is in line with a general increase in porpoise abundance in Dutch waters over that period. The authors also note that acoustic activity was significantly higher inside the wind farm than in the reference areas, indicating that the occurrence of porpoises in the wind farm area increased during the operational period, possibly due to an increase in abundance of prey in this area or as refuge from heavy vessel traffic outside of the wind farm area.

Teilmann and Carstensen (2012) discuss the results of these three studies and are not able to determine why harbor porpoises reacted differently to the Nysted project. One suggestion is that as the area where the Nysted facility occurs is not particularly important to harbor porpoises, animals may be less tolerant of disturbance associated with the operations of the wind farm. It is important to note that the only ESA-listed species that may occur within the WFA that uses echolocation is the sperm whale. Baleen whales, which includes NARWs, fin, blue, and sei whales, do not echolocate. Sperm whales use echolocation primarily for foraging and social communication (Miller et al. 2004; NMFS 2010b; NMFS 2015c; Watwood et al. 2006); sperm whales are expected to be rare in the WFA due to the shallow depths and more typical distribution near the continental shelf break and further offshore. Sperm whale foraging is expected to be limited in the lease area because sperm whale prey occurs in deeper offshore waters, 500-1,000 m (NMFS 2010b). Therefore, even if there was a potential for the presence of the WTGs or foundations to affect echolocation, it is extremely unlikely that this would have any effect on sperm whales given their rarity in the WFA.

Absent any information on the effects of wind farms or other foundational structures on the local abundance or distribution of listed species, it is difficult to predict how listed species will respond to the presence of the foundations in the water column. However, considering just the physical structures themselves, given the

spacing between the turbines we do not expect that the physical presence of the foundations alone will affect the distribution of whales or sea turtles in the action area or affect how these animals move through the area. Additionally, the available data on harbor porpoises supports the conclusion that, if there are decreases in abundance during wind farm construction, those are not sustained during the operational period. Therefore, effects of structure presence to ESA-listed whales and sea turtles would be insignificant.

### **Habitat Conversion and Reef Effect**

Long-term habitat alteration would result from the installation of the foundations, scour protection around the WTG and OSS foundations, as well as cable protection. The footprint of WTG foundations and OSS foundations and associated scour protection, as well as offshore export cable protection, would permanently modify the seabed by converting current soft-bottom to new hard-bottom habitat. In total, permanent habitat disturbance of 232.2 to 259.1 acres (0.94 to 1.05 km<sup>2</sup>) is anticipated to result from the project. The addition of the WTGs and an OSS is expected to result in a habitat shift in the area immediately surrounding each monopile from soft sediment, open water habitat system to a structure-oriented system, including an increase in fouling organisms. Overall, construction of the CVOW-C foundations, cables, and associated scour protection would transform up to 259.1 acres (1.05 km<sup>2</sup>) of soft bottom habitat into coarse, hard bottom habitat (compared to the entire CVOW-C lease area of approximately 112,799 acres [45,658 hectares; 456 km<sup>2</sup>]). Over time (weeks to months), the areas with scour protection are likely to be colonized by sessile or mobile organisms (e.g., sponges, hydroids, crustaceans). This results in a modification of the benthic community in these areas from primarily infaunal organisms (e.g., amphipods, polychaetes, bivalves).

Hard-bottom and vertical structures in a soft-bottom habitat can create artificial reefs, thus inducing the “reef” effect (Taormina et al. 2018). The reef effect is usually considered a beneficial impact, associated with higher densities and biomass of fish and decapod crustaceans in the area immediately surrounding the new structure (Taormina et al. 2018). This could provide a potential increase in available forage items for sea turtles compared to the surrounding soft-bottoms; however, this change in distribution/aggregation of some species does not necessarily increase overall biomass. In the North Sea, Coolen et al. (2018) sampled epifaunal organisms at offshore oil and gas platforms and compared data to samples from the Princess Amalia Wind Farm (PAWF) and natural rocky reef areas. The 60 PAWF monopile turbine foundations with rock scour protection were deployed between November 2006 and March 2007 and surveys were carried out in October 2011 and July 2013. This study demonstrated that the WTG foundations and rocky scour protection acted as artificial reef with a rich abundance and diversity of epibenthic species, comparable to that of a natural rocky reef.

Stenberg et al. (2015) studied the long-term effects of the Horns Rev 1 offshore wind farm (North Sea) on fish abundance, diversity, and spatial distribution. Gillnet surveys were conducted in September 2001, before the WTGs were installed, and again in September 2009, 7 years post-construction at the wind farm site and at a control site 6 km away. The three most abundant species in the surveys were whiting (*Merlangius merlangus*), dab (*Limanda limanda*), and sand lance (*Ammodytidae spp.*). Overall fish abundance increased slightly in the area where the wind farm was established but declined in the control area 6 km away. None of the key fish species or functional fish groups showed signs of negative long-term effects due to the wind farm. Whiting and the fish group associated with rocky habitats showed different distributions relative to the distance to the artificial reef structures introduced by the turbines. Rocky habitat fishes were most abundant close to the turbines while whiting was most abundant away from them. The authors also note that the wind farm development did not appear to affect the sand-dwelling species dab and sand lance, suggesting that the direct loss of habitat (<1% of the area around the wind farm) and indirect effects (e.g. sediment composition) were too low to influence their abundance. Species diversity was significantly higher close to the turbines. The authors conclude that the results indicate that the WTG foundations were large enough to attract fish species with a

preference for rocky habitats, but not large enough to have adverse negative effects on species inhabiting the original sand bottom between the turbines. However, more research is still needed within offshore wind farm areas because each offshore wind farm area contains different environmental characteristics. For instance, research from Daewel et al. (2022) suggest changes in organic sediment distribution and quantity could have an effect on the habitat quality for benthic species such as *Ammodytes* spp. (e.g., sand lance) that live in the sediments within wind farm areas.

Methratta and Dardick (2019) carried out a meta-analysis of studies in Europe to examine finfish abundance inside wind farms compared to nearby reference sites. The overall effect size was positive and significantly different from zero, indicating greater abundance of fish inside of wind farm areas compared to the reference sites. More specifically, the study determined increases were experienced for species associated with both soft-bottom and complex-bottom habitat but changes in abundance for pelagic species were not significantly different from zero. The authors report that no significant negative effects on abundance were identified.

Hutchison et al. (2020) describes benthic monitoring that took place within the Block Island Wind Farm (Rhode Island) to assess spatiotemporal changes in sediment grain size, organic enrichment, and macrofauna, as well as the colonization of the jacket foundation structures, up to four years post-installation. The greatest benthic modifications occurred within the footprint of the foundation structures through the development of mussel aggregations. Additionally, based on the presence of juvenile crabs (*Cancer* sp.), the authors conclude that the BIWF potentially serves as a nursery ground, as suggested from increased production rates for crabs (*Cancer pagurus*) at European OWFs (Krone et al. 2017). The dominant mussel community created three-dimensional habitat complexity on an otherwise smooth structure, benefiting small reef species such as cunner (*Tautoglabrus adspersus*), while at a larger scale, the turbine structures hosted abundant black sea bass (*Centropristis striata*) and other indigenous benthopelagic fish.

For the CVOW-C project, effects to listed species from the loss of soft bottom habitat and conversion of soft bottom habitat to hard bottom habitat may occur if this habitat shift resulted in changes in use of the area (considered below) by listed species or resulted in changes in the availability, abundance, or distribution of forage species.

The only forage fish species we expect to be impacted by the loss of soft-bottom habitat would be sand lance (*Ammodytes* spp.). The ESA-listed species in the WDA that may forage on sand lance include Atlantic sturgeon, fin, and sei whales. As sand lance are strongly associated with sandy substrate, and the project would result in a loss of such soft bottom, there would be a reduction in availability of habitat for sand lance that theoretically could result in a localized reduction in the abundance of sand lance in the action area. However, even just considering the lease area, which is dominated by sandy substrate, the loss or conversion of soft bottom habitat is very small, approximately 0.23% of the lease area (and less of the action area). The results from Stenberg et al. (2015; summarized above) suggest that this loss of habitat is not great enough to impact abundance in the area and that there may be an increase in abundance of sand lance despite this small loss of habitat. However, even in a worst case scenario assuming that the reduction in the abundance of sand lance is directly proportional to the amount of soft substrate lost, we would expect a 0.23% reduction in availability of sand lance in the lease area and an even smaller reduction across the action area in the sand lance available as forage for fin and sei whales and Atlantic sturgeon in the action area. Given this small, localized reduction in sand lance and that sand lance are only one of many species the fin and sei whales and Atlantic sturgeon may feed on in the action area, any effects to these species are expected to be so small that they cannot be meaningfully measured, evaluated, or detected and are, therefore, insignificant.

Based on the available information (e.g., Methratta and Dardick 2019; Stenberg et al. 2015), we expect that there may be an increase in abundance of schooling fish in the WFA that sei or fin whales may prey on but that

this increase may be a result of redistribution of species to the WFA rather than a true increase in abundance. Either way, at the scale of the action area, the effects of any increase in abundance of schooling fish resulting from the reef effect will be so small that the effects to sei or fin whales cannot be meaningfully measured, evaluated, or detected. Similarly, we expect that there may be an increase in jellyfish and other gelatinous organism prey of leatherback sea turtles but that at the scale of the action area, any effects to leatherback sea turtles will be so small that they cannot be meaningfully measured, evaluated, or detected. Because we expect sperm whale foraging to be limited in the WFA (due to the shallow depths and location inshore of the shelf break), any effects to sperm whale foraging as a result of localized changes in the abundance or distribution of potential prey items are extremely unlikely.

Atlantic sturgeon would experience a reduction in infaunal benthic organisms, such as polychaete worms, in areas where soft substrate is lost or converted to hard substrate. As explained above, the action area is not an aggregation area or otherwise known to be a high use area for foraging. Any foraging by Atlantic sturgeon is expected to be limited to opportunistic occurrences. Similar to the anticipated reduction in sand lance, the conversion of soft substrate to hard substrate may result in a proportional reduction in infaunal benthic organisms that could serve as forage for Atlantic sturgeon. Assuming that the reduction in the abundance of infaunal benthic organisms in the action area is directly proportional to the amount of soft substrate lost, we would expect an extremely small (0.23% of the lease area and an even smaller percentage of the total action area) reduction in the abundance of these species as forage for Atlantic sturgeon in the action area. Given that any reduction in potential prey items for Atlantic sturgeon will be small, localized, and patchy and that the WDA is not an area that sturgeon are expected to be dependent on for foraging, any effects to Atlantic sturgeon are expected to be so small that they cannot be meaningfully measured, evaluated, or detected and are, therefore, insignificant. Also, to the extent that epifaunal species richness is increased in the WFA due to the reef effect of the WTGs and their scour protection, and to the extent that sturgeon may feed on some of these benthic invertebrates, any negative effects may be offset.

The available information suggests that the prey base for Kemp's ridley and loggerhead sea turtles may increase in the action area due to the reef effect of the WTGs, associated scour protection, and an increase in crustaceans and other forage species. However, given the small size of the area impacted and any potential resulting increase in available forage, any effects of this patchy and localized increase in abundance are likely to be so small that they cannot be meaningfully measured, evaluated, or detected and, thus, would be insignificant. No effects to the forage base of green sea turtles are anticipated as no effects on marine vegetation are anticipated.

No effects to copepods that serve as the primary prey for right whales are anticipated to result from the reef effect considered here. In Section 7.2.9 below on changes to oceanographic conditions, we explain how the physical presence of the foundations may affect ecological conditions that could impact the distribution, abundance, or availability of copepods.

As described above, changes in use of the area by ESA-listed species and changes to their prey species due to habitat conversion because of the project are expected to be insignificant; thus, effects to ESA-listed species would be insignificant.

### **7.2.9 Changes in Oceanographic and Hydrological Conditions**

The proposed project area is located within the Mid-Atlantic Bight. Here, we consider the best available information on how the presence and operation of WTGs and the OSSs from the proposed CVOW-C project may affect the oceanographic and atmospheric conditions in the action area and whether there will be any consequences to listed species. A number of theoretical, model-based, and observational studies have been conducted to help inform the potential effects offshore wind farms may have on the oceanic and atmospheric

environment; summaries of several of these studies are described in this section. In 2022, NMFS contracted with EA Engineering to prepare a literature review on this topic. Much of the information in this section of the biological opinion is based on that review. In general, most of these studies discuss local scale effects (within the area of the wind farm) and are focused in Europe where commercial-scale offshore wind farms are already in operation. At various scales, documented effects include increased turbulence, changes in sedimentation, reduced water flow, and changes in hydrodynamics, wind fields, stratification, water temperature, nutrient upwelling, and primary productivity (van Berkel et al. 2020).

Two turbines were installed offshore Virginia in the summer of 2020 where the weather and hydrodynamic conditions were measured during the installation period; however, no additional reports or literature about oceanographic or atmospheric impacts during operation has been published (HDR 2020). Similarly, no reports or literature about oceanographic or atmospheric impacts during operation of the 5 turbines at the Block Island Wind Farm have been published.

### **Background Information on Oceanic and Atmospheric Conditions in the Project Area**

The broadest area, the U.S. Northeast Shelf Large Marine Ecosystem, extends from the Gulf of Maine to Cape Hatteras, North Carolina (Kaplan 2011). The WDA is located within the Southern Mid-Atlantic Bight sub-region of the Northeast U.S. Shelf Ecosystem, which is distinct from other regions based on differences in productivity, species assemblages and structure, and habitat features (Cook and Auster 2007). The physical oceanography of this region is influenced by the seafloor, freshwater input from multiple rivers and estuaries, large-scale weather patterns, and tropical or winter coastal storm events. Weather-driven surface currents, tidal mixing, and estuarine outflow all contribute to driving water movement through the area (Kaplan 2011).

A variety of existing oceanographic research and monitoring is conducted in the region by state and Federal agencies, academic institutions, and non-governmental organizations using an array of platforms including ships, autonomous vehicles, buoys, moorings, and satellites. Research and monitoring efforts include measuring the physical and biological structure of the ocean environment including variables such as temperature, chlorophyll, and salinity at a range of depths as well as long-term shelf-wide surveys that provide data used to estimate spawning stock biomass, overall fish biodiversity, zooplankton abundance, information on the timing and location of spawning events, and insight to detect changes in the environment. Prominent bottom features of the Mid-Atlantic Bight include a series of ridges and troughs.

On a seasonal scale, the greater Mid-Atlantic Bight region experiences one of the largest transitions in stratification in the entire ocean (Castelao et al. 2010). Starting in the late spring, a strong thermocline develops at approximately 20 m depth across the middle to outer shelf, and forms a thermally isolated body of water known as the “cold pool” which shifts annually but generally extends from the waters of southern New England (in some years, the WDA is on the northern edge of the cold pool) to Cape Hatteras. Starting in the fall, the cold pool breaks down and transitions to cold and well-mixed conditions that last through the winter (Houghton et al. 1982). The cold pool is particularly important to a number of demersal and pelagic fish and shellfish species in the region, but also influences regional biological oceanography as wind-assisted transport and stratification have been documented to be important components of plankton transport in the region (Checkley et al. 1988; Cowen et al. 1993; Grothues et al. 2002; Hare and Cowen 1996; Munroe et al. 2016; Narváez et al. 2015; Sullivan et al. 2006)

The region also experiences upwelling in the summer driven by southwest winds associated with the Bermuda High (Glenn et al. 2004; Glenn and Schofield 2003). Cold nutrient-rich water from the cold pool can be transported by upwelling events to surface and nearshore waters. At the surface, this cold water can form large phytoplankton blooms, which support many higher trophic species (Sha et al. 2015).



The cold pool supports prey species for ESA-listed species, both directly through providing habitat and indirectly through its influence on regional biological oceanography, which supports a productive ecosystem (Chen et al. 2018; Kane 2005; Winton et al. 2018). Lower-trophic plankton species are well adapted to take advantage of the variable seasonality of the regional ecosystem, and support the upper food web for species such as pelagic fish, sea turtles, and marine mammals (Kenney and Vigness-Raposa 2010; Pershing and Stamieszkin 2019). Though plankton exhibit movement behavior, physical and oceanographic features (e.g. tidal mixing fronts, thermal fronts, freshwater plumes, internal waves, stratification, horizontal and vertical currents, and bathymetry) are the primary drivers that control aggregations and concentrate them by orders of magnitude (Pershing and Stamieszkin 2019).

Many marine species including fish, sea turtles, and marine mammals forage around these physical and oceanographic features where prey is concentrated. Physical and oceanographic features are the primary drivers that control aggregations and concentrations of plankton. ESA-listed species in the region primarily feed on five prey resources: zooplankton, pelagic fish, gelatinous organisms, marine vegetation, and benthic mollusks. Of the listed species in the area, NARWs and blue whales are the only obligate zooplanktivores (i.e., they eat only zooplankton). Blue whale presence in the WFA is expected to be rare and foraging is not anticipated. Sei and fin whales may be present in the WFA, however in addition to plankton both species eat small schooling fish. The influence of this bathymetric feature on prey is particularly relevant to NARWs and leatherback sea turtles as their prey is planktonic (calanoid copepods and gelatinous organisms), as described above physical and oceanographic features are the primary drivers that control aggregations and concentrations of plankton. Other listed species, which eat fish, cephalopods, crustaceans, and marine vegetation, are not as closely tied to physical oceanographic features that concentrate prey, given those species' prey are either more stationary on the seafloor or are more able to move independent of typical ocean currents.

### **Effects on Water Temperature**

A modeling study was conducted for the Great Lakes region of the U.S. to simulate the impact of 432 9.5 MW (4.1 GW total) offshore wind turbines on Lake Erie's dynamic and thermal structure. Model results showed that the wind farms did have an impact on the area they were built in by reducing wind speed and wind stress, which led to less mixing, lower current speeds and higher surface water temperature (Afsharian et al. 2020). The model demonstrated reduced wind speed and stress leading to less mixing, lower current speeds, and higher surface water temperatures (1-2.8°C, depending on the month). No changes to temperatures below the surface are reported. The authors note that these impacts were limited to the vicinity of the wind farm. Though modeled in a lake environment, these results may be informative for predicting effects in the marine environment as the presence of structures and interactions with wind and water may act similarly; however, given the scale of the model and specificity of the modeled conditions and outputs to Lake Erie it is not possible to directly apply the results to an offshore wind project in the action area generally or the CVOW-C project in particular.

Some literature is available that considers the potential impacts of wind power development on temperature. Miller and Keith (2018) developed a model to better understand climatic impacts due to wind power extraction; however, the paper addresses how a modeled condition would affect average surface temperatures over the continental U.S. and does not address offshore wind turbines or any effects on ocean water temperatures. Wang and Prinn (2010 and 2011) carried out modeling to simulate the potential climatic effects of onshore and offshore wind power installations; they found that while models of large scale onshore wind projects resulted in localized increases in surface temperature (consistent with the pattern observed in the Miller and Keith paper), the opposite was true for models of offshore wind projects. The authors found a local cooling effect, of up to 1°C, from similarly sized offshore wind installations. The authors provide an explanation for why onshore and offshore turbines would result in different localized effects.

Golbazi et al. (2022) simulated the potential changes to near-surface atmospheric properties caused by large offshore wind farms equipped with offshore wind turbines of 10 and 15 MW. In the model, they simulated 30 GW of offshore wind turbines located in identified lease and planning areas in the U.S. Atlantic. The model results show that, at hub height, an average wind speed deficit of 0.5 m/s extends up to 50 km downwind from the edge of the farms with an average wind speed reduction at the surface that is 0.5 m/s or less (a 10% maximum reduction) within the project footprint. This results in a slight cooling, up to  $-0.06$  K, at the surface in the summer. The authors conclude that, on average, meteorological changes at the surface induced by 10-15 MW offshore wind turbines will be nearly imperceptible in the summer. They also note that future research is needed to explore changes in other seasons.

If the effects predicted by the model in Golbazi et al. and Wang and Prinn are realized as a result of the CVOW-C project, minor cooling of waters in the action area in the summer months would be expected. We do not anticipate that any minor cooling of waters in the action area in the summer months would have any effects to the abundance or distribution of listed species or the abundance or distribution of prey. Based on the available information, any effects to listed species from any changes in water temperature (if there are any at all) will be so small that they cannot be meaningfully measured, evaluated, or detected and are therefore, insignificant.

### **Ocean-Atmosphere and Wind Field Interactions**

Studies have examined the wind wakes produced by turbines and the subsequent turbulence and reductions in wind speed, both in the atmosphere and at the ocean surface. Alterations to wind fields and the ocean-atmosphere interface have the potential to modify both atmospheric and hydrodynamic patterns, potentially on large spatial scales up to dozens of miles from the offshore wind facility (Christiansen et al. 2022; Dorrell et al. 2022; Gill et al. 2020). Interactions between the ocean and the atmosphere in the presence of wind turbine structures are highly variable based on ambient wind speed, the degree of atmospheric stability, and the number of turbines in operation. In general, as an air current moves towards and past a turbine, the structure reduces air velocities downstream and has the potential to generate turbulence near the ocean surface. This relative velocity deficit and increased turbulence near turbine structures create a cone-shaped wake of wind change (known as wind wake) in the downstream region. Studies elucidating the relationship between offshore wind facilities and the atmospheric boundary layer, meteorology, downstream areas, and the interface with the ocean are still emerging. As noted above, no in-situ studies have been carried out in the U.S. to date.

Generally, a wind energy facility is expected to reduce average wind speeds both upstream and downstream; however, studies report a wide range of values for average wind speed deficits, in terms of both magnitude and spatial extent. Upstream of a large, simulated offshore wind facility, Fitch et al. (2012) found wind blocking effects to reduce average wind speeds by 1% as far as 9 miles (15 km) ahead of the facility. Downstream of an offshore wind facility, wind speeds may be reduced up to 46%, with wind wakes ranging from 3 to 43 miles (5 to 70 km) from the turbine or array (Cañadillas et al. 2020; Carpenter et al. 2016; Christiansen and Hasager 2005; Floeter et al. 2022; Platis et al. 2018; van Berkel et al. 2020). Wind speed deficit is greatest at hub height downstream of the facility, with the deficit decreasing closer to the ocean surface (Golbazi et al. 2022). Simulations of multiple clustered, large offshore wind facilities in the North Sea suggest that wind wake may extend as far as 62 miles (100 km) (Siedersleben et al. 2018). In the northeast shelf, wind wakes emerging from simulations of full lease area buildouts were shown to combine and extend as far as 93 miles (150 km) on certain days (Golbazi et al. 2022). Wind speed reduction may occur in an area up to 100 times larger than the offshore wind facility itself (van Berkel et al. 2020). A recent study has investigated long-range wind wake deficit potential in the New York Bight offshore development area using weather research and forecasting (WRF) offshore wind facility parameterization. ArcVera Renewables (2022) determined that expert literature

that used engineering wake loss models has under-predicted wind wakes, and their study describes wind wakes that extend up to or greater than 62 miles (100 km) downstream of large offshore wind facilities.

A study on the effect of large offshore wind farms (~ 80 turbines) in Europe on the local wind climate using satellite synthetic aperture radar found that a decrease of the mean wind speed is found as the wind flows through the wind farms, leaving a velocity deficit of 8–9% on average, immediately downstream of the wind turbine arrays. Wind speed was found to recover to within 2% of the free stream velocity over a distance of 5–20 km past the wind farm, depending on the ambient wind speed, the atmospheric stability, and the number of turbines in operation (Christiansen and Hasager 2005). Using an aircraft to measure wind speeds around turbines, Platis et al. (2018) found a reduction in wind speed within 10km of the turbine.

### **Ocean-Atmosphere Responses to Wind Field Interactions**

The disturbance of wind speed and wind wakes from wind farms can cause oceanic responses such as upwelling, downwelling, and desertification (Dorrell et al. 2022; Floeter et al. 2022; van Berkel et al. 2020). According to Broström (2008), a wind farm can cause a divergence/convergence in the upper ocean due to a strong horizontal shear in the wind stress and resulting curl of the wind stress. This divergence and convergence of wind wakes can cause upwelling and downwelling. Upwelling can have significant impacts on local ecosystems due to the influx of nutrient rich, cold, deep water that increases biological productivity and forms the basis of the lower trophic level. Broström (2008) indicates that the induced upwelling by a wind farm will likely increase primary production, which may affect the local ecosystem. Oceanic response to an altered wind field is predicted to extend several kilometers around offshore wind facilities and to be strong enough to influence the local pelagic ecosystem (Broström 2008; Floeter et al. 2022; Ludewig 2015). Floeter et al. (2022) conducted the first observations of wind wake-induced upwelling/downwelling dipoles and vertical mixing downstream of offshore wind facilities in the North Sea. The study identified two characteristic hydrographic signatures of wind wake-induced dipoles. First, distinct changes in mixed layer depth and water column potential energy anomaly were observed over more than 3 miles (5 km). Second, the thermocline exhibited diagonal excursions, with maximum vertical displacement of 46 ft (14 m) over a dipole dimension of 6–7 miles (10–12 km). Additionally, preliminary research by Daewel et al. (2022) suggests that ongoing offshore wind energy developments can have a significant impact on coastal marine ecosystems. This study deduced that wind wakes of large offshore wind energy clusters in the North Sea cause large-scale changes in annual primary production with local changes of up to 10%. These changes occur within the immediate vicinity of the offshore wind energy cluster and travel over a wider region (up to 1–2 km outside the cluster of projects).

Wave amplitude within and surrounding offshore wind energy facilities may be altered by changes to the wind field. A decrease in surface roughness can be observed in optical and radar images at considerable distances down-wind of a wind farm under certain conditions (Forster 2018). Johnson et al. (2021) analyzed localized turbulence effects of various proposed offshore wind build-out scenarios using a three-dimensional model from Cape Hatteras to offshore Cape Cod, with a finer mesh embedded in the Massachusetts/Rhode Island wind energy area. Results of the hydrodynamic modeling suggested that the extraction of wind energy by offshore wind facilities in the Massachusetts/Rhode Island wind energy area could reduce current magnitude and wave height. By modifying the sea surface wind shear stress, wind energy extraction affected the wind field within and beyond the modeled facility (comprising a full build-out of the wind energy area with 1,063 turbines, each 12-MW). Relative to the modeled baseline, significant wave height was reduced by up to 2.46 ft (0.75 m) inside the facility, by up to 1.48 ft (0.45 m), just outside the facility, and up to 0.49 ft (0.15 m) at the coast.

The regional impact of wind wakes is challenging to quantify due to natural spatiotemporal variability of wind fields, sea levels, and local ocean surface currents in the northeast shelf (Floeter et al. 2022). Individual dipole patterns can either superimpose or decrease airflow velocities, for example depending on the spatial orientation

of the tidal ellipse in relation to the direction of the wind wake (Floeter et al. 2022). Increased airflow velocities near the water surface result in decreased water surface elevation of a 2-mm magnitude, while decreased airflow velocities result in increased water surface elevation of a similar magnitude (Christiansen et al. 2022). This magnitude may be negligible in the context of the substantial year-to-year changes in annually averaged coastal sea level in the northeast shelf (i.e., 650 mm), which is attributed to the region's existing along-shelf wind stress (Andres et al. 2013; Li et al. 2014). Christiansen et al. (2022) modeled sea surface velocity changes downstream of multiple offshore arrays in the North Sea and found that induced changes equated to a "substantial" 10–25% of the interannual and decadal sea surface velocity variability in the region.

### **Hydrodynamic Interactions**

The introduction of offshore wind energy facilities into ocean waters influences adjacent ocean flow characteristics, as turbine foundation structures and currents, tides, etc. interact. The dynamics of ocean flow past vertical structures has received relatively more study in well-mixed seas than in strongly stratified seas (Dorrell et al. 2022). Most studies on wake and turbulence caused by foundation structures are gleaned from modeled simulations, as field studies are challenging due to the numerous variables and natural variability in flow (Schultze et al. 2020). Only two studies to date have observed in situ the response of stratified waters to the presence of offshore wind energy facilities (Floeter et al. 2017; Schultze et al. 2020).

Hydrodynamic effects of offshore wind facilities and their secondary effects are only beginning to be studied within United States shelf waters. Johnson et al. (2021) prepared a hydrodynamic modeling study investigating the potential impacts of offshore wind energy development on oceanographic conditions in the northeast shelf, assessing the changes in hydrodynamic conditions resulting from a theoretical modeled offshore wind facility in the Massachusetts-Rhode Island offshore wind energy area. The results suggest that introduction of 1,063 12 MW WTGs would influence the thermal stratification by introducing additional mixing. The model suggests a relative deepening in the thermocline compared to baseline temperatures of approximately 3.3 to 6.6 ft (1 to 2 m) and retention of colder water within the footprint of the modeled wind facility through the summer months (Johnson et al. 2021). The study also suggested that the thermocline would on average move deeper in both the spring and summer models, with more cold water retained within the footprint of the offshore wind facility (Johnson et al. 2021).

The results of Johnson et al. (2021) contrast with a European field study by Floeter et al. (2017) in the German North Sea, which found a doming of the thermocline and enhanced mixing, or more uniform temperatures, in the layer below the thermocline. While the Floeter et al. (2017) study observed changes in vertical mixing, and enhanced local upwelling, these changes may be due to natural variability. Additionally, there are numerous differences between the sites in Southern New England and the German North Sea. First, the climate setting and hydrodynamic conditions differ (e.g., offshore wind facility locations relative to the shelf, general circulation around the offshore wind facilities, temperature and stratification regime, depth, and solar radiation and heat transfer). Second, the operational status of the actual and modeled offshore wind facilities differs (i.e., there being no current speed reduction due to wind wake loss in the German North Sea study) (Johnson et al. 2021). Additionally, while Johnson et al. (2021) conclude that the introduction of the offshore wind energy structures modifies temperature stratification by introducing additional mixing, the model did not include influences from strong storms, which are a primary component of mixing in the Southern New England region. The authors acknowledge that the model's single year of simulations would require additional years to assess year-to-year variability of the model parameters and that modeling of this nature is more suited for a review of differences between scenarios rather than absolute accuracy of individual scenarios.

Using remote sensing, Vanhellefont and Ruddick (2014), showed that offshore wind farms can have impacts on suspended sediments. Wakes of turbidity from individual foundations were observed to be in the same

direction as tidal currents, extending 30–150 m wide, and several km in length. However, the authors indicate the environmental impact of these wakes and the source of the suspended material were unknown. Potential effects could include decreased underwater light field, sediment transport, and downstream sedimentation (Vanhellemont and Ruddick 2014).

The primary structure-induced hydrodynamic effects of wind turbine foundations are friction and blocking, which increase turbulence, eddies, sediment erosion, and turbidity in the water column (van Berkel et al. 2020). A number of studies have investigated the impacts of offshore wind farms on stratification and turbulence (Carpenter et al. 2016; Dorrell et al. 2022; Schultze et al. 2020). As water moves past wind turbine foundations the foundations generate a turbulent wake that will contribute to a mixing of a stratified water column or may disperse aggregations of plankton. These studies have demonstrated decreased flow and increased turbulence extending hundreds of meters from turbine foundations. However, the magnitude is highly dependent on the local conditions (e.g. current speed, tides, and wind speed), with faster flow causing greater turbulence and extending farther from the foundation. Carpenter et al. (2016) used a combination of numerical models and in situ measurements from two wind farms (Bard 1 and Global Tech 1) to conduct an analysis of the impact of increased mixing in the water column due to the presence of offshore wind structures on the seasonal stratification of the North Sea. Based on the model results and field measurements, estimates of the time scale for how long a complete mixing of the stratification takes was found to be longer, though comparable to, the summer stratification period in the North Sea. The authors concluded that it is unlikely the two wind farms would alter seasonal stratification dynamics in the region. The estimates of mixing were found to be influenced by the pycnocline thickness and drag of the foundations of the wind turbines. For there to be a significant impact on stratification from the hydrodynamic impacts of turbine foundations over a large area, large regions (length of 100 km) of the North Sea would need to be covered with wind farms; however the actual threshold was not defined (Carpenter et al. 2016). Schultze et al. (2020) found similar results in the same area of the German Bight of the North Sea.

Monopiles were found to increase localized vertical mixing due to the turbulence from the wakes generated from monopiles, which in turn could decrease localized seasonal stratification and could affect nutrient cycling on a local basis. Using both observational and modeling methods to study impacts of turbines on turbulence, Schultze et al. (2020) found through modeling simulations that turbulent effects remained within the first 100 m of the turbine foundation under a range of stratified conditions. Field measurements at the OWF DanTysk in the German Bight of the southern North Sea, observed a wake area 70 m wide and 300 m long from a single monopile foundation during weak stratification (0.5°C surface-to bottom temperature difference). No wake or turbulence was detected in stronger thermal stratification (~3°C surface-to-bottom temperature difference) (Schultze et al. 2020). The OWF DanTysk is composed of 6 m diameter monopiles. Similarly, a laboratory study measured peak turbulence within 1 monopile diameter distance from the foundation and that downstream effects (greater than 5% of background) persisted for 8–10 monopile diameters distances from the foundation (Miles et al. 2017).

Impacts on stratification and turbulence could lead to changes in the structure, productivity, and circulation of the oceanic regions; however, the scale and degree of those effects is dependent in part on location. If wind farms are constructed in areas of tidal fronts, the physical structure of wind turbine foundations may alter the structure of fronts, which could affect distribution of prey and lead to effects to the marine vertebrates that use these oceanic structures for foraging (Cazenave et al. 2016). As areas of frontal activity are often pelagic biodiversity hotspots, altering their structure may decrease efficient foraging opportunities for listed species. In an empirical biophysical study, Floeter et al. (2017) used a remotely operated vehicle to record conductivity, temperature, depth, oxygen, and chlorophyll-a measurements of an offshore wind farm. Vertical mixing was found to be increased within the wind farm, leading to a doming of the thermocline and a subsequent transport

of nutrients into the surface mixed layer. Though discerning a wind farm-induced relationship from natural variability is difficult, wind farms may cause enhanced mixing, and due to the interaction between turbulence levels and the growth of phytoplankton, this could have cascading effects on nutrient levels, ecosystems, and marine vertebrates (Carpenter et al. 2016; Floeter et al. 2017). Water flowing around turbine foundations may also cause eddies to spawn, potentially resulting in more retention of plankton in the region when combined daily vertical migration of the plankton (Chen et al. 2016; Nagel et al. 2018). However, it is important to note that these conclusions from Chen et al. (2016) are hypothesized based on a modeling study and not observed in the region.

Van Berkel et al. (2020) investigated available information on the effects of offshore wind farms on hydrodynamics and implications for fish. The authors report that changes in the demersal community have been observed close to wind farms (within 50 m) and that those changes are related to structure-based communities at the wind farm foundations (e.g., mussels). The authors also report on long-term studies of fish species at the Horns Reef project (North Sea) and state that no significant changes in abundance or distribution patterns of pelagic and demersal fish have been documented between control sites and wind farm sites or inside/between the foundations at wind farm sites. They report that any observed changes in density were consistent with changes in the general trend of species reflected in larger scale stock assessment reports (see also Stenberg et al. 2015).

Modeling experiments have demonstrated that the introduction of monopiles could have an impact on the M2 amplitude (semidiurnal tidal component due to the moon) and phase duration. Modeling showed the amplitude increased between 0.5 and 7% depending on the preexisting amphidrome, defined as the geographical location, which has zero tidal amplitude for 1 harmonic constituent of the tide. Changes in the tidal amplitude may increase the chances of coastal flooding in low-lying areas. However, we have no information to suggest that any potential effects on M2 amplitude would have any effects on marine resources generally or ESA-listed species specifically.

### **Primary Production and Plankton Distribution**

As water flows around turbine and OSS foundations there is the potential that aggregations of planktonic prey may be dispersed due to the increased mixing caused by water moving around foundations; however, it is also possible that foundations act to trap prey if eddies form in the wake of turbine foundations or concentrate prey in a convergent current situation. However, decreased mixing could also cause increased stratification and subsequently affect the exchange of nutrients, heat, and trap prey.

A few studies have been conducted to evaluate how altered hydrodynamic patterns around offshore wind projects could affect primary production as well as upper trophic levels. Floeter et al. (2017) demonstrated with empirical data from the southern North Sea that increased vertical mixing at an offshore wind farm resulted in the transport of nutrients to the surface mixed layer and subsequent uptake by phytoplankton in the photic zone. Increased primary production could increase the productivity of bivalves and other macrobenthic suspension feeders that are expected to be a major component of artificial reef communities that form on turbine foundations (Daewel et al. 2022; Mavraki et al. 2020; Slavik et al. 2019). The results of analyses conducted by Floeter et al. (2017) and Friedland et al. (2021) suggest that wind farm effects on phytoplankton and zooplankton might extend to upper trophic level impacts, potentially modifying the distribution and abundance of finfish and invertebrates. However, the spatial scale of these effects remains unknown but could range from localized within individual farms to broader spatial scales (Bakhoday-Paskyabi et al. 2018; Carpenter et al. 2016).

Wang et al. (2018) evaluated pre and post-construction water column properties (water temperature, dissolved oxygen, and suspended matter concentration) and zooplankton community structure at an offshore wind farm in China. The wind farm consisted of 70 WTGS (232 MW total) located in the intertidal zone less than 11 km from the shore in the Yellow Sea. The goal of this study was to examine the responses of the zooplankton community to the establishment of an OWF, the causes of any observed effects, and their relation to environmental factors in the study area. The analysis documented changes in the zooplankton community (e.g., seasonal increases and decreases in macro- and micro-zooplankton). However, given that there are significant differences in the location and conditions between the site in China and the CVOW-C location (e.g., tidal flat/intertidal zone vs. well offshore) and the layout of the site (WTGs are much closer together at the China site) it is not clear that the results of this study will be informative for the CVOW-C project.

Daewel et al. (2022) used modeling to demonstrate the effects of wind wake from offshore wind projects in the North Sea on primary productivity. The model results show that the systematic modifications of stratification and currents alter the spatial pattern of ecosystem productivity; annual net primary production (netPP) changes in response to OWF wind wake effects in the southern North Sea show both areas with a decrease and areas with an increase in netPP of up to 10%. There was a decrease in netPP in the center of the large OWF clusters in the inner German Bight and at Dogger Bank, which are both situated in highly productive frontal areas, and an increase in areas around these clusters in the shallow, near-coastal areas of the German Bight and at Dogger Bank. The authors note that additional work is needed to identify the robustness of these patterns with respect to different weather conditions and interannual variations. They also note that when integrated over a larger area, the estimated positive and negative changes tend to even out. Besides the changes in the pelagic ecosystem, the model results highlight a substantial impact on sedimentation and seabed processes. The overall, large-scale reduction in average current velocities results in reduced bottom-shear stress to up to 10% locally; however, averaged over larger areas the effect is less pronounced with only a 0.2% increase North Sea wide. The model also indicates an impact of OWF on bottom water oxygen in the southern North Sea. In an area with a bathymetric depression (Oyster Grounds), the dissolved oxygen concentrations in late summer and autumn were further reduced by about 0.3 mg l<sup>-1</sup> on average and up to 0.68 mg l<sup>-1</sup> locally. In other areas of the southern North Sea, the effect was estimated to be less severe, or even showing an increase in dissolved oxygen concentration, for example along the edges of Dogger Bank.

### **Consideration of Potential Effects of the CVOW Wind Farm**

In general, the studies referenced above describe varying scales of impacts on the oceanographic and atmospheric processes as a resultant effect of offshore wind turbine development. These impacts include increased turbulence generated by the presence of turbine foundations, extraction of wind by turbine operations reducing surface wind stress and altering water column turbulence, and upwelling and downwelling caused by the divergence and convergence of wind wakes (Miles et al. 2021). Oceanographic and atmospheric effects are possible at a range of temporal and spatial scales, based on regional and local oceanographic and atmospheric conditions as well as the size and locations of wind farms. However, discerning a wind farm-induced relationship from natural variability is difficult and very specific to local environmental conditions where the wind farm is located. As described above, the particular effects and magnitudes can vary based on a number of parameters, including model assumptions and inputs, study site, oceanographic and atmospheric conditions, turbine size, and wind farm size and orientation (Miles et al. 2021). Here, we consider the information presented above, incorporate the layout and parameters of the CVOW-C project and local oceanographic and atmospheric conditions and evaluate effects to ESA-listed species. We note that while we are using the best available information to assess effects of the CVOW-C project, there is significant uncertainty about how offshore wind farms in the action area may alter oceanographic processes and the biological systems that rely on them. The available information suggests that some impacts require very large scale wind development before they would

be realized; as such, we note that the conclusions reached here are specific to the scope of the CVOW-C project (up to 202 WTGs and their foundations, up to 3 OSSs and their foundations, and total approximate capacity of up to 3,000 MW) and may not be reflective of the consequences of larger scale development in the region or even a single project in a different location.

As explained above, based on the available information, we do not see any evidence that installation of up to 202 WTGs and their foundations and up to 3 OSSs and their foundations for the CVOW-C project would lead to ocean warming that could affect ESA-listed whales, sea turtles or fish or that there is the potential for the CVOW-C project to contribute to or exacerbate warming ocean conditions; if anything, the project may result in minor, localized cooling. The available information suggests that the CVOW-C project will produce wind wake from operation of the turbines and that the foundations themselves will lead to disruptions in local conditions. The scale of these effects is expected to range in distance, with effects to turbulence, eddies, and turbidity extending around 100 m (van Berkel et al. 2020) and changes in mixed layer depth and thermocline conditions extending up to 12 km (Floeter et al. 2022), while alterations to wind fields and the ocean-atmosphere interface have the potential to modify both atmospheric and hydrodynamic patterns, potentially on large spatial scales up to dozens of miles (Christiansen et al. 2022; Gill et al. 2020). As noted above, oceanic response to an altered wind field is predicted to extend several kilometers around offshore wind facilities and to be strong enough to influence the local pelagic ecosystem (Broström 2008; Floeter et al. 2022; Ludewig 2015).

When applying studies conducted outside the Mid-Atlantic Bight region to our consideration of the potential effects of the CVOW-C project on environmental conditions, it should be noted that the seasonal stratification over the summer, particularly in the studies conducted in the North Sea, is much less than the peak stratification seen in the summer over the Mid-Atlantic Bight. The conditions in the North Sea are more representative of weaker stratification, similar to conditions seen in the Mid-Atlantic Bight during the spring or fall. Because of the weaker stratification during the spring and fall, the Mid-Atlantic Bight ecosystem may be more susceptible to changes in hydrodynamics due to the presence of structures during the spring and fall than during highly stratified conditions in the summer.

Offshore wind energy development has the potential to alter the atmospheric and the physical and biological oceanographic environment due to the influence of the wind turbines on the wind stress at the ocean surface and the physical presence of the in-water turbine foundations could influence the flow and mixing of water. Resultant, increased stratification could affect the timing and rate of breakdown of the cold pool in the fall, which could have cascading effects on species in the region. However, as described above, the available information (Carpenter et al. 2016; Schultze et al. 2020) indicates that in order to see significant impacts on stratification, large regions had to be covered by wind turbines. Given the scale of the CVOW-C project (up to 202 WTGs and 2 OSSs), any effects of stratification are not expected to reach the scale that they would affect the timing and rate of breakdown of the cold pool in the fall.

Due to the linkages between oceanography and food webs, lower-trophic level prey species that support protected species may be affected by changes in stratification and vertical mixing. Information on which to base an assessment of the degree that the proposed project will result in any such impacts is limited. No utility scale offshore wind farms exist in the region nor along either coast of the United States to evaluate potential impacts of the proposed Project, thus we primarily have results from research conducted on offshore wind projects in other countries available to evaluate potential impacts on the oceanographic and atmospheric environment, and potential subsequent effects on protected species and their prey.

Results of in-situ research, and modeling and simulation studies, show that offshore wind farms can reduce wind speed and wind stress which can lead to less mixing, lower current speeds, and higher surface water temperature (Afsharian et al. 2020); increase localized vertical mixing due to the turbulence from the wakes



produced from water flowing around turbine foundations (Miles et al. 2017; Schultze et al. 2020); cause wind wakes that will result in detectable changes in vertical motion and/or structure in the water column (upwelling and downwelling) (Broström 2008; Christiansen and Hasager 2005); and result in detectable sediment wakes downstream from a wind farm by increased turbidity (Vanhellemont and Ruddick 2014). We have considered if these factors could result in disruption of prey aggregations, primarily of planktonic organisms transported by currents such as copepods and gelatinous organisms (salps, ctenophores, and jellyfish medusa).

This possible effect is primarily relevant to NARWs and leatherback sea turtles as their planktonic prey (calanoid copepods and gelatinous organisms) are the only listed species' prey in the region whose aggregations are primarily driven by hydrodynamic processes. As aggregations of plankton, which provide a dense food source for listed species to efficiently feed upon, are concentrated by physical and oceanographic features, increased mixing may disperse aggregations and may decrease efficient foraging opportunities for listed species. Potential effects of hydrodynamic changes in prey aggregations are specific to listed species that feed on plankton, whose movement is largely controlled by water flow, as opposed to other listed species which eat fish, cephalopods, crustaceans, and marine vegetation, which are either more stationary on the seafloor or are more able to move independent of typical ocean currents.

Relative to the Mid-Atlantic Bight as a whole, the scale of the proposed Project (no more than 202 WTG foundations and 36 pin pile foundations for the 3 OSSs) and the footprint of the WFA (112,799 acres, 456 km<sup>2</sup>) with project foundations occupying only a small fraction of that) is small. Based on the available information, we do not expect the scope of hydrodynamic effects to be large enough to influence regional conditions that could affect the distribution of prey, mainly plankton, or conditions that aggregate prey in the local area off the coast of Virginia or broader Mid-Atlantic Bight. However, we do expect localized impacts to oceanic conditions that would extend 5-12 km from the border of the lease area.

Although uncertainty remains as to the magnitude and intensity of effects offshore wind farms may have on altering oceanographic processes, studies demonstrate increased turbulence may occur in the wake of turbine (and OSS) foundations. These turbulence wakes have been detected up to 300 m from the turbine foundation (Miles et al. 2017; Schultze et al. 2020). Peak turbulence area is expected within the distance equivalent to the diameter of a single monopole, with turbulence measurable (greater than 5% above background) within a distance equivalent to 8-10 times the diameter of a single monopole (Miles et al. 2017); based on a maximum monopile diameter of 31 ft (9.5 m) for the CVOW-C project that would be a distance of 248 to 310 ft (76 to 95 m). We would expect that any effects on the distribution of prey due to turbulence from the foundation would be limited to the area where changes in turbulence would be experienced. These anticipated localized changes at the WFA and water down-current of the foundations of the wind turbines could result in localized changes in plankton distribution and abundance. Given the available information, we expect these changes to be limited to the area within approximately 1 km of any single foundation (Floeter et al. 2017). Based on the spacing of the turbines (1 nm x 1 nm), the available information suggests limited opportunity for these areas to interact and overlap, which may limit the impact on the distribution of plankton to largely the WFA and up to 1 km around its border. Based on the available information, we do not expect the changes from the CVOW-C project to affect the oceanographic forces transporting zooplankton into the WFA from outside the WFA. Therefore, while there may be changes in the distribution of plankton within the WFA, we do not expect any overall reduction in biomass of plankton. Thus, because we do not anticipate any change in the biomass of zooplankton, we do not anticipate any higher trophic level impacts; that is, we do not anticipate any associated effects to gelatinous organisms, pelagic fish, or benthic invertebrates that depend on plankton as forage.

Right whales are the only ESA-listed obligate zooplanktivores in the project area, feeding exclusively on copepods, which are primarily aggregated by physical and oceanographic features. While we do not expect the

CVOW-C WTGs and the foundations to affect the abundance of copepods in the WFA area or any broader area, the distribution of copepods in the WFA footprint may be affected; however, given the limited foraging by right whales in the WFA and surrounding area that may be affected by changes in ecological conditions, any limited impacts on the distribution of copepods would have effects on right whales that are so small that they cannot be meaningfully measured, evaluated, or detected. Similarly, we do not expect any changes in the abundance of leatherback sea turtle's jellyfish prey, and anticipate that any changes in distribution of jellyfish would have effects on leatherbacks that are so small that they cannot be meaningfully measured, evaluated, or detected. We do not anticipate a larger disruption to conditions that would aggregate prey in the lease area due to the small scale of the project and the distance from frontal features.

Given the localized and patchy effects anticipated to the distribution and aggregation of prey, and that we do not expect any overall reduction in the amount of prey in the action area, any effects to foraging individual right whales or leatherback sea turtles are expected to be so small that they cannot be meaningfully measured, evaluated, or detected and are therefore, insignificant. Additionally, as Atlantic sturgeon in the marine environment primarily feed on benthic invertebrates and small fish such as sand lance, which are either free swimming or live on the seafloor, hydrodynamic effects are not likely to impact the distribution or availability of their prey, and therefore any effects to Atlantic sturgeon are extremely unlikely to occur and thus discountable. Effects to the benthic prey base of green, Kemp's ridley, and loggerhead sea turtles are also extremely unlikely to occur, due to their benthic nature, and thus discountable. As discussed above, we do not expect any impacts to the abundance or distribution of the cephalopods on which sperm whales forage. As a result, any effects to sperm whales are extremely unlikely to occur and thus discountable.

We note that as the scale of offshore wind development in the Mid-Atlantic Bight increases and the area occupied by wind turbines increases, the scope and scale of potential hydrodynamic impacts may also increase and influence the environmental baselines for future projects. Such impacts may require additional research and analysis to support future assessments. Biological opinions prepared for the Vineyard Wind 1, South Fork, Ocean Wind 1, Revolution Wind, and Empire Wind projects assessed the construction, operation, and decommissioning of the project and concluded that there may be localized changes at the wind farms and waters within a few hundred meters down-current of the foundations of the wind turbines. The Vineyard Wind 1 project will consist of up to 100 WTGs, the South Fork project 14 WTGs, the Ocean Wind 1 project 98 WTGs, the Revolution Wind 1 project 100 WTGs, the Empire Wind project 57 WTGs. The closest of these projects to CVOW-C, however, is Ocean Wind 1, at a distance of over 200 km away. Given the distance between these projects to the proposed CVOW-C project, it is not likely any oceanographic or atmospheric effects from the two projects would be magnified, interact, or overlap with the CVOW-C project.

## **7.2.10 Water Quality Effects**

### **Sediment Disturbance and Turbidity**

Sediments in the action are characterized by fine sand and gravel and sand/silt mixes, which make it likely that construction and decommissioning activities could increase turbidity. Seafloor-disturbing activities like pile driving for WTG and OSS installation, placement of scour protection, vessel anchoring, controlled flow evacuations, and burial of the inter-array and offshore export cables may result in increases in suspended sediment. Any sediment sidecast or accumulated along cable trenches could be resuspended. Turbidity caused by installation of WTG and OSS installation or scour protection would be expected to be limited to the area immediately around the foundation or scour area, and the potential for scour is expected to be minimized once installation of scour protection is complete. Atlantic clam surveys would be limited in extent, and any increase in turbidity would be expected to be very small-scale and localized.

Cable installation activities disrupt bottom habitat and suspend sediment in the water column. Cable installation would involve jet plow, jet trenching, chain cutting, trench former, hydroplow, mechanical plowing, pre-trenching, and mechanical trenching. Vinhateiro et al. (2018) modeled anticipated total suspended solids (TSS) levels and the time required to dissipate those levels to ambient conditions. As described in the BA, sediment dispersion modeling was conducted for the COP, which indicated that sediments suspended during trenching would settle quickly to the seabed within the trench and that potential plumes would be limited to right above the seabed. Potential suspended sediment plumes greater than 10 mg/L would be short in duration (up to 4 hours) and limited to within approximately 2,625 ft (800 m) of the center of the trench during flood conditions, and within 1,148 ft (350 m) during ebb conditions. However, Vinhateiro et al. (2018) modeled offshore turbidity levels during the proposed installation of an inter-array cable at 100 mg/L and up to 131 ft (40 m) from the source, with turbidity returning to ambient levels within 0.3 hours post cable installation. Jet plow activities in nearshore areas would be similar to the modeling results for other shallow-water areas where the mostly fine sediment (silts and clays) were projected to persist for 2-days at very low levels of 10 mg/L above background levels (Normandeau 2015).

Effects from seafloor preparation on marine mammals are expected to be short-term and low intensity. Dredging, sandwave leveling, and boulder clearance is expected to be extremely localized at any given time, and it is unlikely that any ESA-listed species would be exposed at levels or durations that would result in adverse effects.

### ***Turbidity Effects on Whales***

In a review of dredging impacts to marine mammals, Todd et al. (2015) found that direct effects from turbidity have not been documented in the available scientific literature. Because whales breathe air, some of the concerns about impacts of TSS on fish (i.e., gill clogging or abrasion) are not relevant. Cronin et al. (2017) suggest that vision may be used by NARWs to find copepod aggregations, particularly if they locate prey concentrations by looking upwards. However, Fasick et al. (2017) indicate that NARWs certainly must rely on other sensory systems (e.g. vibrissae on the snout) to detect dense patches of prey in very dim light (at depths >160 m or at night). Because ESA-listed whales often forage at depths deeper than light penetration, which suggests that vision is not relied on exclusively for foraging, TSS that reduces visibility would not be expected to affect foraging ability. Data are not available regarding whales' avoidance of localized turbidity plumes; however, Todd et al. (2015) conclude that since marine mammals often live in turbid waters and frequently occur at depths without light penetration, impacts from turbidity are not anticipated to occur. As such, any effects to ESA-listed whales from exposure to increased turbidity are extremely unlikely to occur. If turbidity-related effects did occur, they would likely be so small that they cannot be meaningfully measured, evaluated, or detected and would therefore be insignificant.

### ***Turbidity Effects on Sea Turtles***

Similar to whales, because sea turtles breathe air, some of the concerns about impacts of TSS on fish (i.e., gill clogging or abrasion) are not relevant. There is no scientific literature available on the effects of exposure of sea turtles to increased TSS. Michel et al. (2013) indicates that since sea turtles feed in water that varies in turbidity levels, changes in such conditions are extremely unlikely to inhibit sea turtle foraging even if they use vision to forage. Based on the available information, we expect that any effects to sea turtles from exposure to increased turbidity are extremely unlikely to occur. If turbidity-related effects did occur, they would likely be so small that they could not be meaningfully measured, evaluated, or detected and would therefore be insignificant.

### ***Turbidity Effects on Atlantic Sturgeon***

Atlantic sturgeon are adapted to natural fluctuations in water turbidity through repeated exposure (e.g., high water runoff in riverine habitat, storm events) and are adapted to living in turbid environments (Hastings 1983). Atlantic sturgeon forage at the bottom by rooting in soft sediments meaning that they are routinely exposed to high levels of suspended sediments. Few data have been published reporting the effects of suspended sediment on sturgeon. Garakouei et al. (2009) calculated Maximum Allowable Concentrations (MAC) for total suspended solids in a laboratory study with *Acipenser stellatus* and *A. persicus* fingerlings (7-10 cm TL). The MAC value for suspended sediments was calculated as 853.9 mg/L for *A. stellatus* and 1,536.7 mg/L for *A. persicus*. All stellate sturgeon exposed to 1,000 and 2,320 mg/L TSS for 48 hours survived. All Persian sturgeon exposed to TSS of 5,000, 7,440, and 11,310 mg/L for 48 hours survived. Given that Atlantic sturgeon occupy similar habitats as these sturgeon species, we expect them to be a reasonable surrogate for Atlantic sturgeon. Wilkens et al. (2015) contained young of the year Atlantic sturgeon (100-175 mm TL) for a 3-day period in flow-through aquaria, with limited opportunity for movement, in sediment of varying concentrations (100, 250 and 500 mg L<sup>-1</sup> TSS) mimicking prolonged exposure to suspended sediment plumes near an operating dredge. Four-percent of the test fish died; 1 was exposed to 250 TSS and 3 to 500 TSS for the full three-day period. The authors concluded that the impacts of sediment plumes associated with dredging are minimal where fish have the ability to move or escape. As tolerance to environmental stressors, including suspended sediment, increases with size and age (ASMFC 2012); we expect that the subadult and adults in the action area would be less sensitive to TSS than the test fish used in both of these studies.

Any Atlantic sturgeon within 40 m of the cable laying operations for the inter-array cable would be exposed to TSS greater than 100 mg/L (Vinhateiro et al. 2018). These elevated TSS levels are not expected to persist for more than 0.3 hours. Atlantic sturgeon within 800 m of the cable laying operations for the CVOW-C in Federal waters would be exposed to TSS at or below 10 mg/L. Elevated TSS levels associated with CVOW-C cable installation are not expected to persist for more than 4 hours. Based on the information summarized above, any exposure to TSS would be below levels that would be expected to result in any effects to the subadult or adult Atlantic sturgeon occurring in the action area. As such, Atlantic sturgeon are extremely unlikely to experience any physiological or behavioral responses to exposure to increased TSS and, thus, effects would be discountable.

### ***Turbidity Effects on Prey Species***

Sediment disturbance and exposure to increased TSS could affect prey of whales, sea turtles, and Atlantic sturgeon. Here, we provide a brief summary of the prey that the various listed species forage on and then consider the effects on those prey. We conduct this analysis to consider whether listed species could be exposed to adverse effects due to adverse consequences to species on which they forage.

### ***Summary of Information of Feeding of ESA-listed Species***

Right whales feed almost exclusively on copepods, a type of zooplankton. Of the different kinds of copepods, NARWs feed especially on late stage *Calanus finmarchicus*, a large calanoid copepod (Baumgartner et al. 2007), as well as *Pseudocalanus spp.* and *Centropages spp.* (Pace and Merrick 2008). Because a right whale's mass is ten or eleven orders of magnitude larger than that of its prey (late stage *C. finmarchicus* is approximately the size of a small grain of rice), right whales are very specialized and restricted in their habitat requirements – they must locate and exploit feeding areas where copepods are concentrated into high-density patches (Pace and Merrick 2008).

Fin whales in the North Atlantic eat pelagic crustaceans (mainly euphausiids or krill, including *Meganyctiphanes norvegica* and *Thysanoessa inerrnis*) and schooling fish such as capelin (*Mallotus villosus*), herring (*Clupea harengus*), and sand lance (*Ammodytes spp.*) (NMFS 2010a). Fin whales feed by lunging into schools of prey with their mouth open, using their 50 to 100 accordion-like throat pleats to gulp large amounts of food and water. A fin whale eats up to 2 tons of food every day during the summer months.

An average sei whale eats about 2,000 lbs of food per day. They can dive 5 to 20 minutes to feed on plankton (including copepods and krill), small schooling fish, and cephalopods (including squid) by both gulping and skimming.

Sperm whales hunt for food during deep dives with feeding occurring at depths of 500–1000 m depths (NMFS 2010b). Deepwater squid make up the majority of their diet (NMFS 2010b). Given the shallow depths of the area where the cable will be installed (less than 50 m), it is extremely unlikely that any sperm whales would be foraging in the area affected by the cable installation and extremely unlikely that any potential sperm whale prey would be affected by cable installation or dredging activities.

Blue whales feed exclusively on krill. Given the rarity of blue whales in the area where project activities will occur, it is extremely unlikely that any blue whales would be foraging in the area where increased turbidity would occur and extremely unlikely that any potential blue whale prey would be affected by cable installation or dredging activities.

Green sea turtles feed primarily on sea grasses and may feed on algae. Loggerhead turtles feed on benthic invertebrates such as gastropods, mollusks, and crustaceans. Diet studies focused on North Atlantic juvenile stage loggerheads indicate that benthic invertebrates, notably mollusks and benthic crabs, are the primary food items (Burke and Standora 1993; Seney 2003; Youngkin 2001). Limited studies of adult loggerheads indicate that mollusks and benthic crabs make up their primary diet, similar to the more thoroughly studied neritic juvenile stage (Youngkin 2001). Kemp's ridleys primarily feed on crabs, with a preference for portunid crabs including blue crabs; crabs make up the bulk of the Kemp's ridley diet (NMFS et al. 2011).

Leatherback sea turtles feed exclusively on jellyfish. A study of the foraging ecology of leatherbacks off the coast of Massachusetts indicates that leatherbacks foraging off Massachusetts primarily consume the scyphozoan jellyfishes, *Cyanea capillata* and *Chrysaora quinquecirrha*, and ctenophores, while a smaller proportion of their diet comes from holoplanktonic salps and sea butterflies (*Cymbuliidae*) (Dodge et al. 2011); we expect leatherbacks in the CVOW-C area to be foraging on similar species.

Atlantic sturgeon are opportunistic benthivores that feed primarily on mollusks, polychaete worms, amphipods, isopods, shrimps and small bottom-dwelling fishes (Dadswell 2006; Smith 1985). A stomach content analysis of Atlantic sturgeon captured off the coast of New Jersey indicates that polychaetes were the primary prey group consumed; although the isopod *Politolana concharum* was the most important individual prey eaten (Johnson et al. 1997). The authors determined that mollusks and fish contributed little to the diet and that some prey taxa (i.e., polychaetes, isopods, amphipods) exhibited seasonal variation in importance in the diet of Atlantic sturgeon. Novak et al. (2017) examined stomach contents from Atlantic sturgeon captured at the mouth of the Saco River, Maine and determined that American Sand Lance *Ammodytes americanus* was the most common and most important prey.

### ***Effects to Prey Species***

#### ***Copepods***

Copepods exhibit diel vertical migration; that is, they migrate downward out of the euphotic zone at dawn, presumably to avoid being eaten by visual predators, and they migrate upward into surface waters at dusk to graze on phytoplankton at night (Baumgartner and Fratantoni 2008; Baumgartner et al. 2011). Baumgartner et al. (2011) concludes that there is considerable variability in this behavior and that it may be related to stratification and presence of phytoplankton prey with some copepods in the Gulf of Maine remaining at the surface and some remaining at depth. Because copepods even at depth are not in contact with the substrate, we do not anticipate any burial or loss of copepods during installation of the cable. We were unable to identify any scientific literature that evaluated the effects to marine copepods of exposure to TSS. Based on what we know about the effects of TSS on other aquatic life, it is possible that high concentrations of TSS could negatively affect copepods. However, given that: the expected TSS levels are below those that are expected to result in effects to even the most sensitive species evaluated; the sediment plume will be transient and temporary (i.e., persisting in any one area for no more than three hours); elevated TSS is limited to the bottom of the water column near the seafloor, while copepods tend to inhabit higher levels of the water column; and will occupy only a small portion of the WFA at any given time, any effects to copepod availability, distribution, or abundance on foraging whales would be so small that they could not be meaningfully evaluated, measured, or detected. Therefore, the effects are insignificant.

### *Fish*

Anticipated TSS levels are below the levels expected to result in the mortality of fish that are preyed upon by fin or sei whales or Atlantic sturgeon. In general, fish can tolerate at least short-term exposure to high levels of TSS. Wilber and Clarke (2001) reviews available information on the effects of exposure of estuarine fish and shellfish to suspended sediment. In an assessment of available information on sublethal effects to non-salmonids, they report that the lowest observed concentration–duration combination eliciting a sublethal response in white perch was 650 mg/L for 5 d, which increased blood hematocrit (Wilber and Clarke 2001). Regarding lethal effects, Atlantic silversides and white perch were among the estuarine fish with the most sensitive lethal responses to suspended sediment exposures, exhibiting 10% mortality at sediment concentrations less than 1,000 mg/L for durations of 1 and 2 days, respectively (Wilber and Clarke 2001). Forage fish in the action area will be exposed to maximum TSS concentration-duration combinations far less than those demonstrated to result in sublethal or lethal effects of the most sensitive non-salmonids for which information is available. Based on this, we do not anticipate the mortality of any forage fish; therefore, we do not anticipate any reduction in fish as prey for fin or sei whales or Atlantic sturgeon and, thus, the effects are insignificant.

### *Benthic Invertebrates*

Area disturbed during cable installation is likely to result in the mortality of some benthic invertebrates in the path of the jet plow. Immediately following cable installation, this area will likely be devoid of any benthic invertebrates. However, given the narrow area, we expect recolonization to occur from adjacent areas that were not disturbed; therefore, this reduction in potential forage will be temporary.

Because polychaete worms live in the sediment, we do not expect any effects due to exposure to elevated TSS in the water column. Wilber and Clarke (2001) reviewed available information on effects of TSS exposure on crustacean and report that in experiments shorter than 2 weeks, nearly all mortality of crustaceans occurred with exposure to concentrations of suspended sediments exceeding 10,000 mg/L and that the majority of these mortality levels were less than 25%, even at very high concentrations. Wilber and Clarke (2001) also noted that none of the crustaceans tested exhibited detrimental responses at dosages within the realm of TSS exposure anticipated in association with dredging. Based on this information, we do not anticipate any effects to crustaceans resulting from exposure to TSS. Given the thin layer of deposition associated with the settling of

TSS out of the water column, we do not anticipate any effects on benthic invertebrates. Based on this analysis, we expect any impact of the loss of benthic invertebrates to foraging Kemp's ridley and loggerhead sea turtles and Atlantic sturgeon due to turbidity to be so small that they cannot be meaningfully measured, evaluated, or detected and, therefore, are insignificant.

### *Jellyfish*

A literature search revealed no information on the effects of exposure to elevated TSS on jellyfish. However, given the location of jellyfish typically higher in the water column and the sediment plume being limited to the bottom of the water column near the seafloor, we expect any exposure of jellyfish to TSS to be minimal. Based on this analysis, effects to leatherback sea turtles resulting from effects to their jellyfish prey are extremely unlikely to occur and thus discountable.

### **Oil/Chemical Release**

Increased use of vessels and other equipment in the action area results in the potential for accidental release of contaminants into the marine environment. Vessels could generate exhaust fumes and release petroleum-based contaminants during use or refueling. Project vessels also have the potential to generate operational wastes that could affect water quality in the action area. ESA-listed animals could be exposed to these contaminants and degraded water quality. Exposure to aquatic contaminants can cause lethal or sublethal effects to listed species, including physical injury or changes, decreased body condition and fitness, and reduced growth (e.g., Ackleh et al. 2017; Croce and Stagg 1997; Free et al. 2013; Gall and Thompson 2015; Mearns et al. 2017). Such impacts could also impact listed species' prey.

All project vessels would comply with USGS and BOEM requirements for the prevention and control of oil and fuel spills and would implement proposed best management practices (BMPs) for waste management and mitigation to avoid and minimize accidental release of aquatic contaminants. Vessels, particularly those transiting from foreign ports, would also utilize BMPs for ballast or bilge water releases. Training regarding BMPs proposed for waste management and mitigation of marine debris would be provided for project personnel. Dominion Energy will have an Oil Spill Response Plan in place.

Adhering to regulations and implementing BMPs would minimize the likelihood and effects to ESA-listed animals from fuel, hazardous materials, or waste. Such contaminant releases, if any, would occur infrequently, at discrete locations, and vary widely in space and time, such that they could not be meaningfully measured. Therefore, effects from the release of water quality contaminants from project vessels would be insignificant.

### **7.2.11 Electromagnetic Fields and Heat during Cable Operation**

Electromagnetic fields (EMF) are generated by current flow passing through power cables during operation and can be divided into electric fields (called E-fields, measured in volts per meter, V/m) and magnetic fields (called B-fields, measured in  $\mu\text{T}$ ) (Taormina et al. 2018). Buried cables reduce, but do not entirely eliminate, EMF (Taormina et al. 2018). When electric energy is transported, a certain amount is lost as heat by the Joule effect, leading to an increase in temperature at the cable surface and a subsequent warming of the sediments immediately surrounding the cable; for buried cables, thermal radiation can warm the surrounding sediment in direct contact with the cable, even at several tens of centimeters away from it (Taormina et al. 2018).

To minimize EMF generated by cables, all cabling would be contained in electrical shielding to prevent detectable direct electric fields. CVOW-C would bury inter-array cables to a depth of between 3.9 and 9.8 ft (1.2 and 3 m) and offshore export cables to a target depth of between 3.3 and 16.4 ft (1 and 5 m). The electrical shielding and burial are expected to control the intensity of EMF. However, magnetic field emissions cannot be

reduced by shielding, although multiple-stranded cables can be designed so that the individual strands cancel out a portion of the fields emitted by the other strands. Normandeau et al. (2011) compiled data from a number of existing sources, including 19 undersea cable systems in the U.S., to characterize EMF associated with cables consistent with those proposed for wind farms. The dataset considers cables consistent with those proposed by CVOW-C. In the paper, the authors present information indicating that the maximum anticipated magnetic field would be experienced directly above the cable (i.e., 0 m above the cable and 0 m lateral distance), with the strength of the magnetic field dissipating with distance. Based on this data, the maximum anticipated magnetic field would be 7.85  $\mu\text{T}$  at the source, dissipating to 0.08  $\mu\text{T}$  at a distance of 10 m above the source and 10 m lateral distance. By comparison, the Earth's geomagnetic field strength ranges from approximately 20 to 75  $\mu\text{T}$  (Bochert and Zettler 2006b).

When electric energy is transported, a certain amount gets lost as heat, leading to an increased temperature of the cable surface and subsequent warming of the surrounding environment (OSPAR 2009). As described in Taormina et al. (2018), the only published field measurement study results are from the 166 MW Nysted wind energy project in the Baltic Sea (maximal production capacity of about 166 MW), in the proximity of 233 and 132 kV AC cables buried approximately 1 m deep in a medium sand area. In situ monitoring showed a maximal temperature increase of about 2.5 °C at 50 cm directly below the cable and did not exceed 1.4°C in 20 cm depth above the cable (Meißner et al. 2006). Taormina et al. (2018) caution that application of these results to other locations is difficult, considering the large number of factors affecting thermal radiation including cable voltage, sediment type, burial depth, and shielding. The authors note that the expected impacts of submarine cables would be a change in benthic community makeup with species that have higher temperature tolerances becoming more common. Taormina et al. conclude at the end of their review of available information on thermal effects of submarine cables that considering the narrowness of cable corridors and the expected weakness of thermal radiation, impacts are not considered to be significant. Based on the available information summarized here, and lacking any site-specific predictions of thermal radiation from the CVOW-C inter-array cable and CVOW-C export cable, we expect that any impacts will be limited to a change in species composition of the infaunal benthic invertebrates immediately surrounding the cable corridor. As such, we do not anticipate thermal radiation to change the abundance, distribution, or availability of potential prey for any species. As any increase in temperature will be limited to areas within the sediment around the cable where listed species do not occur, we do not anticipate any exposure of listed species to an increase in temperature associated with the cable.

## Whales

The current literature suggests that cetaceans can sense the Earth's geomagnetic field and use it to navigate during migrations but not for directional information (Normandeau et al. 2011). It is not clear whether they use the geomagnetic field solely or in addition to other regional cues. It is also not known which components of the geomagnetic field cetaceans are sensing (i.e. the horizontal or vertical component, field intensity or inclination angle). Marine mammals appear to have a detection threshold for magnetic intensity gradients (i.e. changes in magnetic field levels with distance) of 0.1% of the earth's magnetic field or about 0.05 microtesla ( $\mu\text{T}$ ) (Kirschvink 1990). Assuming a 50-mG (5  $\mu\text{T}$ ) sensitivity threshold (Normandeau et al. 2011), marine mammals could theoretically be able to detect EMF effects from the inter-array and CVOW-C export cables, but only in close proximity to cable segments lying on the bed surface. Individual marine mammals would have to be within 3 ft (0.9 m) or less of those cable segments to encounter EMF above the 50-mG detection threshold.

As described in Normandeau et al. (2011), there is no scientific evidence as to what the response to exposures to the detectable magnetic field would be. However, based on the evidence that magnetic fields have a role in navigation it is reasonable to expect that any effects would be related to migration and movement. Given the



limited distance from the cable that the magnetic field will be detectable, the potential for effects is extremely limited. Even if listed whales did avoid the corridor along the cable route in which the magnetic field is detectable, the effects would be limited to minor deviations from normal movements. As such, any effects are likely to be so small that they cannot be meaningfully measured, detected, or evaluated and are therefore insignificant.

### **Sea Turtles**

Sea turtles are known to possess geomagnetic sensitivity (but not electro sensitivity) that is used for orientation, navigation, and migration. They use the Earth's magnetic fields for directional or compass-type information to maintain a heading in a particular direction and for positional or hemap-type information to assess a position relative to a specific geographical destination (Lohmann et al. 1997). Multiple studies have demonstrated magneto sensitivity and behavioral responses to field intensities ranging from 0.0047 to 4000  $\mu\text{T}$  for loggerhead turtles, and 29.3 to 200  $\mu\text{T}$  for green turtles (Normandeau et al. 2011). While other species have not been studied, anatomical, life history, and behavioral similarities suggest that they could be responsive at similar threshold levels. For purposes of this analysis, we will assume that leatherback and Kemp's ridley sea turtles are as sensitive as loggerhead sea turtles.

Sea turtles are known to use multiple cues (both geomagnetic and nonmagnetic) for navigation and migration. However, conclusions about the effects of magnetic fields from power cables are still hypothetical, as it is not known how sea turtles detect or process fluctuations in the earth's magnetic field. In addition, some experiments have shown an ability to compensate for "miscues," so the absolute importance of the geomagnetic field is unclear.

Based on the demonstrated and assumed magneto sensitivity of sea turtle species that occur in the action area, we expect that sea turtles in the action area will be able to detect the magnetic field. As described in Normandeau et al. (2011), there is no scientific evidence as to what the response to exposures to the detectable magnetic field would be. However, based on the evidence that magnetic fields have a role in navigation it is reasonable to expect that effects would be related to migration and movement; however, the available information indicates that any such impact would be very limited in scope. As noted in Normandeau et al. (2011), while a localized perturbation in the geomagnetic field caused by a power cable could alter the course of a turtle, it is likely that the maximum response would be some, probably minor, deviation from a direct route to their destination. While large numbers of buried cables are present within the U.S. EEZ, we are not aware of any scientific information suggesting that the large body of existing cables has caused measurable or detectable changes to sea turtle navigation. Based on the available information, effects to sea turtles from the magnetic field associated with the CVOW-C inter-array cable and export cables are expected to be so small that they cannot be meaningfully measured, detected, or evaluated and are, therefore, insignificant.

### **Marine Fish**

A number of fish species are suspected of being sensitive to EMF because they have magnetosensitive or electrosensitive tissues, have been observed to use electrical signals in seeking prey, or use the Earth's magnetic field for navigation during migration (EPRI 2013; Gill et al. 2012; Normandeau et al. 2011). Information on the impacts of magnetic fields on fish is limited.

Multiple studies regarding EMF effects have focused in particular on sturgeon species. Sturgeons are electrosensitive and use electric signals to locate prey. Atlantic sturgeon have specialized electrosensory organs capable of detecting electrical fields on the order of 0.5 mV/m (Normandeau et al. 2011). Exponent Engineering (2018) calculated that the maximum induced electrical field strength from inter-array and export cables would

be 0.43 mV/m or less, which is slightly below the detection threshold for this species. However, this analysis only considered EMF associated with buried cable segments. Based on relative magnetic field strength, the induced electrical field in cable segments that are covered by electrical armoring is expected to exceed the 0.5-mV/m threshold. This suggests that Atlantic sturgeon and giant manta ray would be able to detect the induced electrical fields in immediate proximity to those cable segments.

Bevelhimer et al. (2013) examined the behavioral responses of Lake Sturgeon to electromagnetic fields. The authors also report on a number of studies, which examined magnetic fields associated with AC cables consistent with the characteristics of the cables proposed by South Fork Wind and report that in all cases magnetic field strengths are predicted to decrease to near-background levels at a distance of 10 m from the cable. Like Atlantic sturgeon, Lake Sturgeon are benthic oriented species that can utilize electroreceptor senses to locate prey; therefore, they are a reasonable surrogate for Atlantic sturgeon in this context. Bevelhimer et al. (2013) carried out lab experiments examining behavior of individual lake sturgeon while in tanks with a continuous exposure to an electromagnetic source mimicking an AC cable and examining behavior with intermittent exposure (i.e., turning the magnetic field on and off). Lake sturgeon consistently displayed altered swimming behavior when exposed to the variable magnetic field. By gradually decreasing the magnet strength, the authors were able to identify a threshold level (average strength ~ 1,000–2,000  $\mu$ T) below which short-term responses disappeared.

The anticipated maximum exposure of an Atlantic sturgeon to the proposed cable would range from 9.1 to 76.6 milligauss (.91 to 7.66  $\mu$ T). This is several orders of magnitude below the levels that elicited a behavioral response in the Bevelhimer et al. (2013) study. Induced field strength would decrease effectively to 0 mG within 25 ft of each cable (Exponent Engineering 2018). By comparison, the earth's natural magnetic field is more than 5 times the maximum potential EMF effect from the project. Background electrical fields in the action area are on the order of 1 to 10 mG from the natural field effects produced by waves and currents; this is several times higher than the EMF anticipated to result from the project's cables. As such, it is extremely unlikely that there will be any measurable effects to Atlantic sturgeon and other marine fish species due to exposure to the electromagnetic field from the proposed cable. Therefore, effects of EMF produced by the proposed action would be insignificant.

### **Effects to Prey**

We have considered whether magnetic fields associated with the operation of the transmission line could impact benthic organisms that serve as prey to listed species. Effects to forage fish, jellyfish, copepods, and krill are extremely unlikely to occur given the limited distance into the water column that any magnetic field associated with the transmission line is detectable. Information presented in the BA summarizes a number of studies on the effects of exposure of benthic resources to magnetic fields. According to these studies, the survival and reproduction of benthic organisms are not thought to be affected by long-term exposure to static magnetic fields (Bochert and Zettler 2006a; Normandeau et al. 2011). Results from the 30-month post-installation monitoring for the Cross Sound Cable Project in Long Island Sound indicated that the benthos within the transmission line corridor for this project continues to return to pre-installation conditions. The presence of amphipod and worm tube mats at a number of stations within the transmission line corridor suggest construction and operation of the transmission line did not have a long-term negative effect on the potential for benthic recruitment to surface sediments (Ocean Surveys 2005). Therefore, no measurable impacts (short-term or long-term) of magnetic fields on prey for any listed species in the action area are expected, so effects from the proposed action would be insignificant.

### 7.2.12 Fishery Monitoring Surveys

Proposed activities for the CVOW-C project include research based surveys for whelk and black sea bass (see Section 3.6). These surveys will utilize commercial fishing gear to capture the target species. One of the greatest concerns for effects from the application of commercial fishing gear is entanglement of cetaceans and sea turtles in vertical lines, such as for buoys, often used to mark gear location and retrieval. Entanglement could also occur in gill nets for cetaceans, sea turtles, and Atlantic sturgeon. Trawl nets also pose a risk of incidental capture of sea turtles and Atlantic sturgeon.

No trawl nets or gill nets will be used for the CVOW-C fishery monitoring surveys. The only gear to be used is pot traps (like a cage) set on bottom that are used in the whelk and black sea bass commercial fisheries. Sea turtles may attempt to eat the bait or catch inside traps; however, these depredation attempts do not commonly lead to injury or entrapment because of the size and configuration of the traps in comparison to the size of sea turtles in the action area. Since pot traps will be used to target fish, they can be considered to pose a risk of incidental capture for Atlantic sturgeon. Fish traps and pots were not recorded as potential sources for incidental capture of Atlantic sturgeon in data from the Northeast Fisheries Observer Program (Dunton et al. 2015) which has a long history of gear-based monitoring. The lack of Atlantic sturgeon captures in pot traps indicates that incidental captures during the proposed surveys are unlikely.

Typically, commercial pot traps use vertical buoy lines to identify and retrieve the gear. Ropeless (aka “on demand”) systems will be used for the duration of the study to eliminate the need for static vertical buoy lines in the water column. The required ropeless systems makes the potential for entanglement of ESA-listed whales and sea turtles highly unlikely.

The lack of potential for incidental capture or entanglement makes the effects from the proposed whelk and black sea bass surveys discountable.

### 7.2.13 Potential Shifts in Fisheries

Fisheries in and near the lease area are managed at the Federal, state, and regional level. Fishing activity includes a variety of vessel and gear types, including fixed gear (e.g. gillnets, longlines, pot/traps) and mobile gear fisheries (e.g., otter and shrimp trawls), dredge (clam and scallop), hook and line, and spearfishing (BOEM 2022). The primary commercial fishery in the project area is the pot and trap fishery targeting black sea bass and whelk/conch (Buccinidae/Strombidae), and top species by revenue in the project area include black sea bass, channeled whelk, *Illex* sp. squid, summer flounder, longfin squid, Atlantic croaker, red crab, pandalid shrimp, brown shrimp and other shellfish (BOEM 2022). Recreational fisheries’ catch in Virginia includes spot (*Leiostomus xanthurus*), Atlantic croaker, cobia, spotted sea trout (*Cynoscion nebulosus*), black seabass, Spanish mackerel (*Scomberomorus cavalla*), southern kingfish (*Menticirrhus americanus*), red drum, bluefish, striped bass, and tunas (BOEM 2022). Fishing effort is highly variable due to factors including target species distribution and abundance, environmental conditions, fishing regulations, season, and market value. As addressed in the Status of the Species and Environmental Baseline sections of this Opinion, interactions between fishing gear (e.g., bycatch, entanglement) and listed whales, sea turtles, and Atlantic sturgeon occur throughout their range and may occur in the action area.

Here, we consider how the potential shift or displacement of fishing activity from the lease area and cable corridors, because of the proposed project, may affect ESA-listed whales, sea turtles, and Atlantic sturgeon. Potential impacts to fishing activities in the lease area and along the cable corridors during the construction phase of the proposed project are primarily related to accessibility. During the construction and decommissioning phases, potential effects to fishing operations include displacement of vessel transit routes and

shifts in fishing effort due to disruption in access to fishing grounds in the areas where construction activities will occur due to the presence of project vessels and construction activities. Impacts to fishing operations during the operational phase may result from changes in habitat conditions and perceived or real access challenges.

While changes in distribution and abundance of species targeted by commercial fisheries could occur during construction due to exposure to increased sediment, noise, and vibration, these effects are anticipated to be short-term and localized and not result in any changes in abundance or distribution of target species that would be great enough to result in changes in patterns of fishing activity. To the extent that construction has negative effects on the reproductive success of commercial fish species, there is the potential for a decrease in fish abundance and future consequences on fishing activity. Impacts during the decommissioning phase of the Project are expected to be similar. Displacement of fishing vessels and shifts in operations during the construction and decommissioning phases that are related to a shift or change in target species distribution and abundance are expected. Although the magnitude of the shifts is unknown based on the naturally variability of the fisheries, fisheries impacts related to habitat impacts are likely to be related to the footprint of temporary and permanent disturbance (up to 10,270.9 acres of temporary disturbance and 269.1 acres of permanent disturbance) impacted by construction or decommissioning and relatively short construction and decommissioning periods (4-5 years each).

During the operational phase of the project, the potential impacts to fishing activity are primarily anticipated from potential accessibility issues due to the presence and spacing of WTGs and the OSSs as well as potential avoidance of the inter-array and export cable routes due to concerns related to avoiding the potential for snags or other interactions with the cable or cable protection. Additionally, there may be localized impacts on the abundance and distribution of some target species due to changes in habitat conditions (e.g., foundations and scour protection, noise and vibration associated with turbine operations, consequences of reef effect resulting in changes in localized species composition). While there are no restrictions proposed for fishing activity in the WDA, the presence and spacing of structures (less than 1x1 nautical miles) may impede fishing operations for certain gear types. Additionally, the structures will provide new hard bottom habitat in the WDA creating a “reef effect” that may attract fish and, as a result, fishermen, particularly recreational anglers and party/charter vessels. This could create vessel congestion and could dissuade commercial vessels from fishing among the structures.

The potential for shifts in fishing effort due to the proposed project is expected to vary by gear type and vessel size. Of the gear types that fish within the lease area and cable corridors, bottom tending mobile gear is more likely to be displaced than fixed gear, with larger fishing vessels using dredges and trawl gear more likely to be displaced compared to smaller fishing vessels using similar gear types that may be easier to maneuver. However, even without any area use restrictions, there may be different risk tolerances among vessel captains that could lead to at least a temporary reduction in fishing effort in the lease area and along the cable corridors during construction and decommissioning activities, and longer-term reduction of fishing effort during the operational phase of the project. Space use conflicts due to displacement of commercial fishing activity from the lease area to surrounding waters could cause a temporary or permanent reduction in such fishing activities within the lease area and an increase in fishing activities elsewhere. Additionally, there could be increased potential for gear conflicts within the lease area as commercial fisheries and for-hire and private recreational fishing compete for space between turbines, especially if there is an increase in recreational fishing for structure-affiliated species attracted to the foundations (e.g., black sea bass). Fixed gear fisheries, such as the monkfish and spiny dogfish gillnet fishery, may resume or even increase fishing activity in the lease area and along the cable corridors shortly after construction because these fisheries are relatively static (i.e., relatively stationary in location), though there may be small shifts in gear placement to avoid areas very close to project infrastructure. Mobile fisheries, such as surfclam and sea scallop dredging fisheries may take longer to resume

fishing activity within the lease area or along the cable corridors as the physical presence of the new project infrastructure may alter the habitat, behavior of fishing vessels, and target species. However, for all fisheries, any changes in fishing location are expected to be limited to moves to nearby, geographically adjacent areas, particularly on the fringes of the lease area, given the distribution of target species and distance from home ports, all of which limit the potential for significant geographic shifts in distribution of fishing effort.

Fishing vessel activity (transit and active fishing) is high throughout the Mid-Atlantic Bight as a whole, with higher levels of effort occurring outside of the WDA than within the WDA. As noted in the DEIS, the lease area is considered the “least-fished” of the WEAs on the East Coast in terms of fishing intensity (BOEM 2022; Kirkpatrick et al. 2017). The scale of the proposed Project (no more than 205 foundations) and the footprint of the lease area (112,799 acres), with project foundations and associated scour protection occupying only a small fraction of that) relative to the size of available fishing area are small. Fishing activity will not be legally restricted within the lease area and the proposed spacing of the turbines could allow for fishing activity to occur, depending on the risk tolerance of the operator and weather conditions. Any reduction in fishing effort in the lease area would reduce the potential for interactions between listed species and fishing gear in the lease area, yet any beneficial effect would be expected to be so small that it cannot be meaningfully measured, evaluated, or detected. Similarly, any effects to listed species from shifts of fishing effort to areas outside of the WDA are also expected to be so small that they cannot be meaningfully measured, evaluated, or detected. This is because any potential shifts are expected to be limited to small changes in geographic area and any difference in the risk of interaction between fishing gear and listed species is expected to be so small that it cannot be meaningfully measured, detected, or evaluated.

The presence of new structures (e.g., WTGs and OSS foundations) may also act as artificial reefs and could theoretically attract a range of species, including listed species such as sea turtles and sturgeon if the foundations serve to aggregate their prey. Any changes in biomass around the foundations are expected to be so small and localized that they would have insignificant effects on the distribution, abundance, and use of the lease area by listed sea turtles or Atlantic sturgeon. We do not expect that any reef effect would result in any increase in species preyed on by North Atlantic right, fin or sei whales and note that sperm and blue whales are generally not expected to forage in the shallow waters of the lease area. As noted previously, we do not expect any effects on the distribution, abundance, or use of the lease area by ESA-listed whales that would be attributable to the physical presence of the foundations.

This potential increase in biomass around the new structures of the CVOW-C project may result in an increase in recreational anglers targeting structure affiliated fish species and subsequently may increase incidental interactions between recreational anglers and listed species. At the Block Island Wind Farm (Rhode Island), and other offshore wind farms in Europe, recreational fishermen have expressed a generally positive sentiment about the wind farm as an enhanced fishing location due to the structures as there are no other offshore structures or artificial reefs in surrounding waters (Hooper et al. 2017; Smythe et al. 2021; ten Brink and Dalton 2018). Interactions between listed species, particularly sea turtles, and recreational fishing do occur, especially in areas where target species and listed species co-occur (Cook et al. 2020; Rudloe and Rudloe 2005; Seney 2016; Swingle et al. 2017). Listed sea turtles may be attracted to the structures of the foundations to forage and seek refuge and also may be attracted to bait used by anglers, depending on species.

In the area where the proposed CVOW-C project is planned to be built, the habitat is primarily characterized by fine sand and gravel and sand/silt mixes. If there is an increase in recreational fishing in the lease area, it is likely that this will represent a shift in fishing effort from areas outside the lease to within the lease and/or an increase in overall effort to take advantage of the additional hard structure habitat the project would provide. Given the number of foundations (up to 202 WTGs and 3 OSSs) proposed to be installed and vessel safety

concerns regarding being too close to foundations and other vessels, the likelihood of a significant number of recreational fishermen aggregating around the same turbine foundation at the same time is low. It is not likely that targeted recreational fishing pressure will increase to a point of causing a heightened risk of negative impact for any listed species; that is, effects will be so small that they cannot be meaningfully measured, evaluated, or detected and are, therefore, insignificant.

Whales colliding/hitting vessels, primarily recreational vessels engaged in fishing activities is uncommon to begin with, but can happen, primarily when prey of whales and species targeted by fishermen co-occur. It is expected whales will be able to transit the lease area freely given the spacing between turbine foundations, and turbine foundations are not expected to cause an increase in prey that would then result in greater co-occurrence of prey, target species, whales, and vessels and thus risk of whales colliding with vessels engaged in fishing. We expect the risk posed to whales from any shifts and/or displacement of recreational fishing effort caused by the action to be so small that they cannot be meaningfully measured, evaluated, or detected and are therefore, insignificant. For the same reasons, we do not expect any increased vessel strike risk from fishing vessels and Atlantic sturgeon or sea turtles.

In summary, we expect the risks of entanglement, bycatch, or incidental hooking interactions due to any shifts or displacement of recreational or commercial fishing activity caused by the proposed project to be so small that they cannot be meaningfully measured, evaluated, or detected and, thus, the effects are insignificant.

#### **7.2.14 Project Decommissioning**

According to 30 CFR Part 585 and other BOEM requirements, CVOW-C would be required to remove or decommission all installations and clear the seabed of all obstructions created by the proposed project within 2 years of the termination of its lease. All project components would need to be removed 15 ft (4.6 m) below the mudline (30 CFR § 585.910(a)). BOEM expects that WTGs would be disassembled and the piles cut below the mudline. Dominion Energy would clear the area after all components have been decommissioned and perform site clearance bottom surveys to ensure that no unauthorized debris remains on the seabed and the area is cleared of obstructions (Dominion Energy 2023). Offshore export cables and inter-array cables would be removed from the seabed or retired in place; Dominion Energy would need to obtain separate and subsequent approval from BOEM to retire any portion of the project in place (Dominion Energy 2023).

Information on the proposed decommissioning is limited to the information available to us in the BA, DEIS, and COP. Here, we evaluate the information that is available on the decommissioning. We note that prior to decommissioning, CVOW-C would be required to submit a decommissioning plan to BOEM upon the earliest of the following dates: two years before the expiration of the lease, 90 days after completion of the commercial activities on the commercial lease, or 90 days after cancellation, relinquishment, or other termination of the lease (see 30 CFR 585.905). Potential impacts would be re-evaluated at that time. According to BOEM, this approval process would independent of the proposed COP approval. The approval process will include an opportunity for public comment and consultation with municipal, state, and Federal management agencies. CVOW-C would have to apply for an extension to operate the proposed action for more than the operations term or would need to obtain separate and subsequent approval from BOEM to retire any portion of the proposed action in place. Given that approval of the decommissioning plan will be a discretionary Federal action, albeit one related to the present action, we anticipate that a determination will be made based on the best available information at that time whether reinitiation of this consultation is necessary to consider effects of decommissioning that are different from those considered here.

Activities and impacts from project decommissioning are expected to be similar or less than those of construction and installation. Avoidance, minimization, mitigation, and monitoring measures implemented

during decommissioning are expected to be similar to those during construction and installation. It is anticipated that the equipment and vessels used during decommissioning will likely be similar to those used during construction and installation (Dominion Energy 2023). Effects of the vessel traffic anticipated for decommissioning are expected to be consistent with those experiences during construction and installation and are addressed in the vessel effects section of this Opinion. As described below, we have determined that all other effects of decommissioning will be insignificant.

The decommissioning and removal of project components would occur in the reverse sequence as construction and installation, with turbine components or the OSS topside structure removed prior to foundation removal. The WTGs and OSSs decommissioning would include disassembly and removal of the blades, rotor, nacelle, and tower and transport for recycling using vessels and cranes similar to those used during construction. The WTG and OSS foundations would be cut off 15 ft (4.6 m) below the mud line and lifted off by a heavy lift vessel to a barge. It is anticipated that the steel tower and blades will be recyclable. Cables would be lifted out and cut into pieces or reeled in, then transported to port for recycling. We determined that acoustic and habitat based effects of cable installation would be insignificant or extremely unlikely to occur; as the cable removal will essentially follow the same process as cable installation except in reverse, we expect that effects will be the same and therefore would also be insignificant or extremely unlikely to occur.

BOEM did not provide any estimates of underwater noise associated with pile cutting, and we did not identify any reports of underwater noise monitoring of pile cutting with the proposed methods. Hinzmann et al. (2017) reports on acoustic monitoring of removal of a met-tower monopile associated with the Amrumbank West offshore wind project in the North Sea off the coast of Germany. Internal jet cutting (i.e., the cutter was deployed from inside the monopile) was used to cut the monopile approximately 2.5 m below the mudline. The authors report that the highest sound levels were between 250 and 1,000 Hz. Frequent stopping and starting of the noise suggests that this is an intermittent, rather than continuous noise source. The authors state that values of 160 dB SELcum and 190 dB Peak were not exceeded during the jet cutting process. At a distance of 750 m from the pile, noise attenuated to 150.6 dB rms. For purposes of this consultation, and absent any other information to rely on, we assume that these results are predictive of the underwater noise that can be expected during pile removal during project decommissioning. As such, using these numbers, we would not expect any injury to any listed species because the expected noise levels are below the injury thresholds for whales, sea turtles, and Atlantic sturgeon. We also do not expect any exposure to noise that could result in behavioral disturbance of sea turtles or whales because the noise is below the levels that may result in behavioral disturbance.

Any Atlantic sturgeon within 750 m of the pile being cut would be exposed to underwater noise that is expected to elicit a behavioral response. Exposure to that noise could result in short-term behavioral or physiological responses (e.g., avoidance, stress). Exposure would be brief, just long enough to detect and swim away from the noise, and consequences limited to avoidance of the area within 750 m of the pile during. As such, effects to Atlantic sturgeon will be so small that they cannot be meaningfully measured, evaluated, or detected, and would be insignificant.

Scour protection around the base of each foundation would be removed unless consultation with appropriate authorities deems leaving it in place is appropriate. Removal of the scour protection at foundations and along the cable route would reverse the conversion of soft bottom habitat to hard bottom habitat that would occur as a result of project construction. Removal of the foundations would remove the potential for reef effects in the lease area. As we determined that effects of habitat conversion due to construction would be insignificant, we expect the reverse to also be true and would expect that effects of habitat conversion back to pre-construction conditions would also be insignificant.

### 7.3 Stressors Likely to Adversely Affect

We evaluated the potential stressors that are likely to adversely affect ESA-listed species and discuss those stressors in the following subsections. These stressors include noise from pile driving WTG and OSS foundations that are likely to adversely affect NARWs, fin whales, sei whales, sperm whales, Northwest Atlantic DPS loggerhead sea turtles, North Atlantic DPS green sea turtles, Kemp's ridley sea turtles and leatherback sea turtles; and project-related vessel strike that is likely to adversely affect Northwest Atlantic DPS loggerhead sea turtles, North Atlantic DPS green sea turtles, Kemp's ridley sea turtles and leatherback sea turtles. We also determined that project related vessel strike is likely to adversely affect Atlantic sturgeon, while BOEM's effect determination is that vessel strike is not likely to adversely affect Atlantic sturgeon.

#### 7.3.1 Pile driving WTG and OSS Foundations

The most potentially harmful sources of underwater noise generated by the CVOW-C project is from pile driving during installation of the WTG and OSS foundations, both vibratory and impact pile driving will be used to install monopiles and pin piles. Dominion Energy used acoustic propagation modeling of the various foundation installation scenarios to determine distances to the established PTS and behavioral disturbance thresholds (see Section 7.1 for thresholds) for ESA-listed species (Appendix Z; Dominion Energy 2023). Installation of both foundation types would occur in two years, 2024 and 2025, with a third year as contingency, see schedule in Table 2. The foundation pile driving will only occur between May and October of each year to avoid the time of the year NARWs have an increased presence in the region.

All WTG monopile foundations would first be installed using vibratory pile-driving methods (non-impulsive noise) prior to impact pile driving (impulsive noise) to reduce the risk of pile run. The modeling by Dominion Energy assumed installation of a monopile under one of the three following scenarios (see Section 3.2.2) using comparable hammer energies for all scenarios: Scenario 1 considered the Standard Driving Schedule of one monopile foundation installed (60 min vibratory, 85 min impact) in a 24-hour period; Scenario 2 considered the Hard-to-Drive Schedule of one monopile foundation is installed (30 min vibratory, 99 min impact) in a 24-hour period where additional impact pile driving time is required to reach the target penetration; Scenario 3 considered a combination of One Standard and One Hard-to-Drive Schedule where two monopile foundations are installed in a 24-hour period, one using the Standard Driving Schedule, and the other following the Hard-to-Drive Schedule, with a total of 90 min vibratory pile driving and 184 min impact pile driving for both foundations.

The OSS foundations will be installed using similar methods of vibratory pile driving prior to impact pile driving to reduce the risk of pile run, when a pile unexpectedly penetrates the seabed at an uncontrolled speed. The modeling assumed up to two pin piles would be installed per day, requiring up to 120 minutes of vibratory pile driving followed by 410 minutes of impact pile driving for both pin piles.

Sound fields for the WTG were modeled at two representative locations (a shallow and deep location) in the Lease Area and sound fields for the OSS foundations were modeled at the location where the greatest sound propagation was expected out of the three proposed OSS locations. The underwater sound propagation will vary depending on the location of the WTG, but the maximum reported ranges assumed the deeper water depth for all WTG foundations, providing the maximum potential underwater area filled with sound from installation pile driving. Soft-start procedures (Appendix A, copy of Table 1-7) were incorporated into the modeling for all WTG scenarios and the OSS scenario using the piling schedule. Inclusion of the soft-start procedure in the modeling accounts for the acoustic propagation and overall sound field produced from the entire pile driving effort. The modeling does not use any aversion or fleeing behavior to account for any potential mitigative effects that the soft-start procedure would have on ESA-listed species. The propagation modeling assumes a 10



dB noise reduction from the pile source due to the use of proposed noise abatement systems. The modeled distance ranges indicate the area over which noise produced by the project activity may exceed a given threshold following a single impact hammer strike or 1 second of vibratory hammering (for Lpk and SPL metrics) and for 24-hours of pile driving activity based on predefined piling schedules (for SEL<sub>24h</sub> metric).

Exposure modeling was conducted to estimate the number of animals expected to receive sound levels above established acoustic thresholds, which combines animal movement modeling with the sound fields produced by each pile type and scenario using an Acoustic Integration Model© (Marine Acoustics, Inc.). The modeling used the pile driving installation schedule in Table 2. Simulations were run for each species and pile driving scenario in which simulated animals (i.e., animats) were randomly distributed throughout the modeling environment and the predicted received level was recorded every 30 seconds for each animat to create a sound exposure history. Animats are modeled to move throughout the simulated environment following known behavioral rules for each species based on available studies (Tetra Tech 2022b). The sound exposure histories are then subsampled based on the expected duration of the activity (e.g., a monopile foundation may take up to 3 hours to install so 3-hour exposure histories were extracted from each scenario for each species) and then applied to the relevant species' density estimates.

### Whales

The maximum modeled ranges for each pile type and scenario are summarized in Table 34 for the ESA-listed cetaceans (see Table 35 for the density estimates used). The resulting estimated number of ESA-listed cetacean species exposed to PTS or behavioral-level noise from the foundation pile driving are summarized in Table 36.

**Table 34. Maximum distances (m) for WTG and OSS foundation installation scenarios with 10 dB noise mitigation to PTS and behavioral thresholds for cetaceans.**

Scenario	Installation Method	Marine Mammal Hearing Group					
		LFC			MFC		
		PTS (SEL <sub>24h</sub> )	PTS (Lpk)	Behavior (SPL)	PTS (SEL <sub>24h</sub> )	PTS (Lpk)	Behavior (SPL)
WTG Monopile 1 – Standard Installation	Impact	4,396	132	6,182	170	29	6,182
	Vibratory	141	NA	8,866	0	NA	8,866
WTG Monopile 2 – Hard-to-drive Installation	Impact	4,980	132	6,182	187	29	6,182
	Vibratory	113	NA	8,866	0	NA	8,866
WTG Monopile 3 – One Standard and One Hard-to-drive	Impact	5,663	132	6,182	226	29	6,182
	Vibratory	158	NA	8,866	0	NA	8,866
OSS Foundation	Impact	2,680	0	2,172	48	0	2,172
	Vibratory	75	NA	3,601	0	NA	3,601

Source: Dominion Energy 2022

dB = decibel; LFC = low-frequency cetacean; Lpk = peak sound pressure level in units of dB referenced to 1 micropascal; MFC = mid-frequency cetacean; NA = not applicable for this installation method; OSS = offshore substation; PTS = permanent threshold shift; SEL<sub>24h</sub> = sound exposure level over 24 hours in units of dB referenced to 1 micropascal squared second; SPL = root-mean-square sound pressure level in units of dB referenced to 1 micropascal; WTG = wind turbine generator.

**Table 35. Mean seasonal density estimates (animals/km<sup>2</sup>) for ESA-listed cetacean species in the project-buffered (8.9 km) lease Area.**

Species	Spring (May)	Summer (June – August)	Fall (September – October)
Fin whale	0.00069	0.00036	0.00019
NARW	0.00015	0.00004	0.00005
Sei whale	0.00021	0.00001	0.00004
Sperm whale	0.00003	0.00000	0.00000

Source: Tetra Tech (2022a).

**Table 36. Annual estimated number of ESA-listed cetaceans exposed to PTS and behavioral threshold noise during pile driving installation of WTG and OSS foundations using both impact and vibratory pile driving with 10 dB noise mitigation.**

Species	Construction Year	PTS Exposures	Behavioral Exposures
Fin whale	2024	4	112
	2025	3	90
<b>Total</b>		<b>7</b>	<b>202</b>
NARW	2024	0 <sup>a</sup>	6
	2025	0 <sup>a</sup>	6
<b>Total</b>		<b>0</b>	<b>12</b>
Sei Whale	2024	1	3
	2025	1	2
<b>Total</b>		<b>2</b>	<b>5</b>
Sperm whale	2024	0	3
	2025	0	3
<b>Total</b>		<b>0</b>	<b>6</b>

dB = decibels; ESA = Endangered Species Act; OSS = offshore substation; PTS = permanent threshold shift; WTG = wind turbine generator. Source: Tetra Tech (2022a).

<sup>a</sup> One PTS exposure was estimated for NARWs, but due to mitigation measures proposed by the Applicant, no PTS (Level A takes) exposures are not expected by BOEM and no Level A takes have been requested for the ITA.

Up to seven fin whales and two sei whales were estimated as exposed to underwater noise levels above PTS thresholds from pile-driving noise. The threshold distances to PTS are up to several kilometers for impact pile driving but, at most, 158 m for vibratory pile driving (Table 34), and, as a non-impulsive sound source, the vibratory pile driving does not have a peak threshold. Impact hammer installation of the pile foundations produces the most intense underwater noise, especially for the WTG monopiles, with the greatest potential to cause PTS effects on marine mammals. The potential for serious injury is reduced by the implementation of pre-clearance, shutdown zones, and soft-starts for impact pile-driving operations. These measures also make it less likely that any ESA-listed cetacean will be exposed to pile driving that would result in serious injury, such as severe hearing impairment, and would be more likely to result in more moderate and mild forms of PTS (i.e., minor degradation of hearing capabilities at some hearing thresholds). Soft-starts could deter cetaceans from impact pile-driving activities because marine mammals are expected to move away from a sound source that is annoying, thereby avoiding more intense exposures that could result in a serious injury (Southall 2016; Southall et al. 2007a). Studies on soft-starts of marine seismic surveys (i.e., airgun arrays) have shown mixed results for efficacy and seem to be highly contextual (Barkaszi et al. 2012; Barkaszi and Kelly 2019; Dunlop 2016). Therefore, soft-start procedures may be effective in reducing high-level exposure but cannot be assumed to be fully effective. The proposed requirement that impact pile driving can only commence when the pre-clearance zones (Table 10) are fully visible to PSOs helps ensure the ability to detect cetaceans and implement these zones to avoid serious injury. Another consideration is the commitment to achieve at least a 10 dB reduction in pile driving noise using noise abatement systems. It is possible that a greater than 10 dB reduction could be achieved and, if that was only 1 or 2 dBs less, because it is a logarithmic scale it would further reduce the level of potentially harmful noise propagation.

The peak sound pressure PTS threshold distance is small, 132 m, and it is unlikely the large ESA-listed cetaceans will approach the pile driving activities that closely. The clearance and shutdown zones are at least ten times that distance (Table 10). The cumulative PTS distances consider total estimated daily exposure, meaning a cetacean would have to remain within that threshold distance over the entire duration of the noise during the day of exposure to experience PTS. It is unlikely that a whale would stay in the noise field for an extended duration. Additionally, the clearance zone for fin and sei whales is 5,100 m for a single monopile and 6,500 m for a two pile per day scenario, covering the entirety of the cumulative PTS distances to help avoid that level of exposure. The shutdown of 1,750 m for fin and sei whales does not cover the cumulative PTS distances but is expected to reduce the severity of potential exposures to that level of noise. The considerable distances that will be used for clearance and shutdown zones will help avoid exposure and reduce the intensity of any sound exposure that does occur above the PTS threshold for sei and fin whales, but we cannot rule out that some PTS may occur for these whales. Because of the required measures in the ITA and the conditions of the COP designed to minimize exposure or effects of exposure, including the clearance and shutdown zones, we do not expect severe hearing impairment or serious injury to fin and sei whales. We believe the measures to reduce the received levels of noise and the short duration of exposure, if whales were to be within the threshold distance to PTS, minimize the risk that animals would suffer PTS. However, 2 sei and 7 fin whales could experience PTS over the two years of pile driving activities for WTG and OSS foundation installation.

No PTS exposures were estimated for sperm whales. The low density of sperm whales (Table 35) and the small distances to the PTS thresholds for MFC (Table 34) make the occurrence of PTS effects for sperm whales resulting from WTG and OSS foundation pile driving highly unlikely and therefore, discountable.

One PTS exposure per year was estimated from the exposure modeling for NARWs during foundation installation pile driving (Tetra Tech 2022a). However, BOEM considers the proposed mitigation measures outlined in Appendix A (copies of Tables 1-7 and 1-8) to eliminate the potential for NARWs to suffer PTS from exposure to noise from pile driving WTG and OSS foundation installations. For the same reason, no Level A

MMPA take is requested or proposed for NARWs in the ITA. The following measures are considered in making this decision:

- Foundation installation will only occur between May and October, which avoids the winter and spring seasons when NARW presence is likely greater;
- Pre-clearance monitoring and shutdowns during foundation installation will occur at any distance from the source if a NARW is detected visually or acoustically;
- PSOs will visually monitor from the foundation construction vessel and a minimum of two PSO monitoring vessels will be required to fully monitor the maximum 6-km PTS range estimated for LFC;
- A real-time PAM system will be designed and deployed to supplement visual monitoring and PAM operators would review data from at least 24 hours prior to pile driving;
- Daily monitoring of NARW sighting databases;
- A soft-start procedure will be implemented.

These measures minimize exposure of NARWs by restricting installation to the period when fewer animals are likely to be present, increase the opportunity to detect NARWs, and help reduce the amount of time an individual could receive acoustic energy above the PTS onset threshold, lowering the risk of cumulative exposure that could result in PTS. Because these measures are designed to minimize exposure or effects of exposure, we do not expect severe hearing impairment or serious injury to NARW. We believe the measures to reduce the received levels of noise and the short duration of exposure, if whales were to be within the threshold distance to PTS, make it extremely unlikely that animals would suffer PTS and, thus, the effects are discountable.

Exposure modeling estimates that up to 202 fin whales, 12 NARWs, 5 sei whales, and 6 sperm whales could be exposed to noise that meets or exceeds the behavioral thresholds during installation of the WTG monopile and OSS jacket foundations (Table 36). How these whales will react to exposure and the consequences of those reactions could vary widely. Potential effects associated with exposure above the behavioral threshold include temporary behavioral modifications, most likely in the form of avoidance behavior or potential alteration of vocalizations. In addition to behavioral response, these individuals may experience TTS, which represents primarily tissue fatigue and is reversible (Henderson et al. 2008). While experiencing TTS, the hearing threshold rises, and a sound must be at a higher level in order to be heard; that is, the animal experiences a temporary loss of hearing sensitivity. Hearing sensitivity can be regained within minutes or up to a few days of exposure (Finneran 2015), and is not expected to affect the health of any whale or its long-term ability to migrate or forage (Southall et al. 2007a).

There are reports of mid-frequency cetaceans having behavioral reactions of short-term avoidance or displacement from pile-driving sites (Branstetter et al. 2018; Goldbogen et al. 2013; Graham et al. 2017; Wursig et al. 2000). There is a lack of species-specific studies of mysticete behavioral responses to pile-driving activities. Some avoidance and displacement of baleen whales have been documented during other impulsive noise-generating activities such as marine seismic surveys, which may be used as a proxy to determine the potential behavioral reactions. The distance at which responses occur to seismic airguns depends on many factors, including the volume of the airgun (and consequently sound source level), as well as the hearing sensitivity, behavioral state, and even life stage of the animal (Southall et al. 2021).

If animals are exposed to underwater noise above behavioral thresholds, it could result in displacement of individuals from a localized area around a pile (up to 8.9 km; Table 34). Displacement could be temporary for the duration of activity, not quite 5 hours per 24-hour period for both vibratory and impact pile driving of two piles per day, or displacement could extend beyond the duration of the activity. Cetaceans could resume their previous behavior following the cessation of active pile driving. An animal that was migrating through the area

and was exposed to pile driving noise above the behavioral threshold could make minor alterations to their route, taking them a few kilometers out of their way.

Modeling results indicate that dominant frequencies of impact pile-driving activities for the proposed action were concentrated below 1 kHz (Appendix Z; Dominion Energy 2023), which overlaps with the hearing sensitivity of LFC species, indicating that acoustic masking can occur. This also overlaps with the frequency range of sperm whale hearing and vocalizations but it is not within their peak sensitivity range. Thus, there would be fewer effects of masking possible for MFC because they are more tuned to noise outside the range of pile driving. There is evidence that some marine mammals can compensate for the effects of acoustic masking by changing their vocalization rates (Blackwell et al. 2013; Cerchio et al. 2014; Di Iorio and Clark 2010), increasing call amplitude (Holt et al. 2009; Scheifele et al. 2005), or shifting the dominant frequencies of their calls (Lesage et al. 1999; Parks et al. 2007b). When effects of masking cannot be compensated for, increasing noise could affect the ability to locate and communicate with other individuals. Considering that the pile-driving will occur intermittently during construction for less than 5 hours per day, auditory masking, if any occurs, would have limited durations.

Sei and sperm whales are most likely to occur in deeper water slopes and canyon environments, and their densities are expected to be low in the project area (see Table 35). Behavioral reactions to noise exposures above the behavioral thresholds are less likely for these species because their preferred habitat is farther offshore. The separation of noise exposure estimates above the behavioral threshold that also have the potential to cause TTS, which represents a stronger exposure, was not provided by the action agencies. Because we do not have the separate TTS exposure estimate information, we cannot rule out the occurrence of harassment for sei and sperm whales because of foundation pile driving noise.

The proposed mitigation measures are expected to reduce the occurrence and intensity of exposure to sound above behavioral thresholds for ESA-listed cetaceans, but, due to the size of the behavioral threshold distance range (2.2 to 8.9 km), behavioral exposures will not be completely avoided. Some level of harassment of up to 202 fin whales, 12 NARWs, 5 sei whales, and 6 sperm whales is expected from exposure to foundation pile driving noise above behavioral thresholds. Measurable behavioral responses of these whales will largely be temporary avoidance and displacement but masking is also possible during pile driving for WTG and OSS foundation piles.

### Sea Turtles

The maximum modeled distances to sea turtle acoustic thresholds for each foundation pile driving scenario are summarized in Table 37 (see Table 38 for the density estimates used). Estimates from exposure modeling for sea turtle species exposed to noise from the foundation pile driving are summarized in Table 39.

**Table 37. Maximum distances (m) to sea turtle thresholds for WTG and OSS foundation pile driving scenarios with 10 dB noise mitigation.**

Scenario	Installation Method	PTS (Lpk)	PTS (SEL <sub>24h</sub> )	TTS (Lpk)	TTS (SEL <sub>24h</sub> )	Behavior (SPL)
WTG Monopile 1 - Standard Installation	Impact	10	1,044	67	3,575	2,146
	Vibratory	NA	6	NA	179	82

Scenario	Installation Method	PTS (Lpk)	PTS (SEL <sub>24h</sub> )	TTS (Lpk)	TTS (SEL <sub>24h</sub> )	Behavior (SPL)
WTG Monopile 2 - Hard-to-drive Installation	Impact	10	1,142	67	3,902	2,146
	Vibratory	NA	0	NA	132	82
WTG Monopile 3 - One Standard and One Hard-to-drive	Impact	10	1,410	67	4,812	2,146
	Vibratory	NA	8	NA	200	82
OSS Foundation	Impact	0	653	0	2,303	742
	Vibratory	NA	0	NA	94	7

dB = decibel; Lpk = peak sound pressure level in units of dB re 1 micropascal; OSS = offshore substation; PTS = permanent threshold shift; SEL<sub>24h</sub> = sound exposure level over 24 hours in units of dB referenced to 1 micropascal squared second; SPL = root-mean-square sound pressure level in units of dB referenced to 1 micropascal; TTS = temporary threshold shift; WTG = wind turbine generator. Source: Dominion Energy 2022

**Table 38. Estimated seasonal densities (animals/km<sup>2</sup>) for sea turtle species occurring in the Project area**

Species	Spring (May)	Summer (June through August)	Fall (September and October)
Green sea turtle <sup>a</sup>	0.04584	0.06558	0.04584
Kemp’s ridley sea turtle	0.05472	0.05472	0.05472
Leatherback sea turtle	0.00301	0.00137	0.00301
Loggerhead sea turtle <sup>b</sup>	2.514	1.385	1.289

Source: Table 8, (COP Appendix GG; Dominion Energy 2023).

<sup>a</sup> Population data were insufficient to determine an individual species density estimate for the green sea turtles in the Department of the Navy (2007) dataset. However, the available data for the green sea turtles were included in the hard-shelled guild density estimate. Thus, the hard-shelled turtle guild density estimate was used as a surrogate density for the green sea turtles.

<sup>b</sup> Densities for loggerhead sea turtles use data from Barco et al. (2018) rather than the Department of the Navy (2007) dataset which was used for all other species in the table.

**Table 39. Annual estimated number of sea turtles exposed to PTS or behavioral-level noise from WTG and OSS foundation pile-driving with 10-dB noise mitigation.**

Species	Construction Year	PTS Exposures	Behavioral Exposures
Green sea turtles	2024	24	114

	2025	22	101
<b>Total</b>		<b>46</b>	<b>215</b>
Kemp's ridley sea turtle	2024	24	112
	2025	20	91
<b>Total</b>		<b>44</b>	<b>203</b>
Leatherback sea turtle	2024	1	5
	2025	1	3
<b>Total</b>		<b>2</b>	<b>8</b>
Loggerhead sea turtle	2024	657	3,134
	2025	557	2,630
<b>Total</b>		<b>1,214</b>	<b>5,764</b>

Source: COP Appendix GG; Dominion Energy (2023). dB = decibel; ESA = Endangered Species Act

Due to a lack of at-sea density estimates available for green turtles, they were included in the “hard shelled guild” density dataset used by the U.S. Navy (2007). The seasonal density estimates from this guild as a whole were used as surrogate densities for the green sea turtle representing the best available data for this area and, as a result, the exposures may be overestimated for green sea turtles.

Modeling results for sea turtle PTS threshold distances range from 0 to 8 m (0 to 26 ft) for vibratory pile driving of foundations (Table 37). We agree with BOEM that the potential effects of PTS from vibratory pile driving of foundations are discountable for sea turtles because the distances from the noise source to the PTS threshold are so small they are extremely unlikely to result in exposures because animals are unlikely to be so close to pile driving activities. Modeling results from impact pile driving to the sea turtle PTS distances (Table 37) for the peak sound pressure level threshold range from 0 m for the OSS pin piles to 10 m (33 ft) for WTG monopiles, and, for the cumulative sound exposure level, range from 653 (2,142 ft) for the OSS pin piles to 1,410 m (4,625 ft) for the WTG monopiles. The distance to the peak pressure threshold is so small that is extremely unlikely to result in exposures to sea turtles because animals are unlikely to remain close to pile driving activities.

Estimated exposures resulting from impact pile driving to sound at or above the cumulative PTS cumulative threshold were the highest for loggerhead sea turtles at 1,214 individuals total for 2024 and 2025 (Table 39). The loggerhead densities were from Barco et al. (2018), which has more recent data than the density source for the other sea turtle species from the U.S. Navy (2007). Barco et al. (2018) applied a seasonal detectability correction factor that is considered to provide the maximum potential value for loggerhead sea turtles in the area.

The proposed clearance zone for sea turtles during impact pile driving is 1,000 m with a shutdown range of 100 m. Sea turtles are considerably smaller than the ESA-listed whales considered in this Opinion and much more inconspicuous due to a limited profile at the surface of the water. In good visibility conditions, it may be possible to detect sea turtles at 500 m using powerful binoculars, but the effective range for reliable and consistent visual detection of sea turtles from vessels is often less than that (Barkaszi and Kelly 2019; Smultea Environmental Sciences 2020; Vandeperre et al. 2019). Under the proposed measures of PSOs using Big Eye binoculars on the raised construction vessel and up to two PSO vessels circling the pile location, the ability to

effectively clear the entire PTS isopleth area for sea turtles is still uncertain, thus the risk of PTS exposure remains. The proposed mitigation and monitoring measures (clearance, ramp up, shutdowns) will reduce the risk of PTS occurrence and the severity of PTS that could occur for sea turtles but will not eliminate the risk. Because the proposed clearance zone does not fully encompass the PTS range from impact pile driving of foundations and the proposed shutdown zone is significantly smaller than that, the likelihood for sea turtles to experience PTS-level exposures during impact pile driving of foundations cannot be discounted. The cumulative threshold considers total estimated daily exposure, requiring a sea turtle to remain within that threshold distance over the entire duration of that noise during the day of exposure to experience the effects of PTS. A sea turtle is more likely to move away, especially if pile driving sound is perceived as an unpleasant noise, than to remain for the duration, which reduces the potential for PTS effects to occur. If PTS were to occur, it constitutes harm under the ESA because it results in injury to the individual.

Unlike PTS, TTS is non-permanent and is recoverable. Effects of TTS could disrupt sea turtle behavior and functions because of auditory fatigue, but disruption would be temporary. Neither Dominion Energy nor BOEM modeled the number of sea turtles expected to be exposed to noise above the TTS threshold, thus, we do not have exposure estimates to evaluate but we can calculate distances to sea turtle TTS thresholds.

Results for the sea turtle TTS distances for the peak sound pressure level threshold from impact pile driving range from 0 m for the OSS pin piles to 67 m (220 ft) for WTG monopiles (Table 37). Exposure to sound at this level is expected to be rare because sea turtles are not expected to be close to operating equipment because equipment presence is likely to cause turtles to leave the area, and the use of PSOs and shutdown zones will minimize the likelihood for turtles to be present in the zone during pile driving activity. The peak pressure TTS threshold distances are small and shorter than the shutdown distance (100 m), so sea turtle exposure to the effects of TTS from foundation impact pile peak pressure is expected to be rare.

Results for the cumulative TTS threshold distances for sea turtles from vibratory pile driving range for 94 m (308 ft) for the OSS pin piles to 200 m (656 ft) for WTG monopiles (Table 37). A sea turtle would have to remain within that threshold distance over the entire duration of exposure to experience effects of TTS. The clearance distance (1,000 m) is much greater than the threshold, and the shutdown distance (100 m) covers all of the distance for monopiles and at least half the threshold distance for the pin piles. A sea turtle is more likely to move away, especially if the noise is perceived as unpleasant or aversive, than to remain for the duration of pile driving activities. For these reasons, exposure at the cumulative TTS threshold for sea turtles from vibratory pile driving of foundations is expected to be limited.

Modeled distances to the cumulative TTS threshold for sea turtles from impact pile driving range from 2,303 m (7,555 ft) for the OSS pin piles to 4,812 m (15,787 ft) for WTG monopiles (Table 37). These distances are beyond the shutdown (100 m) and clearance (1,000 m) zones for sea turtles. As previously mentioned, a sea turtle is more likely to move away, especially from aversive noise, than to remain for the duration needed to reach the cumulative threshold, although the distance to this threshold means the possibility of TTS effects cannot be completely ruled out. A portion of sea turtles exposed to sound from foundation impact pile driving could experience some degree of TSS.

Sea turtles do not use sound to communicate and are not known to depend heavily on acoustic cues for vital biological functions (Nelms et al. 2016b; Popper and Hawkins 2014). Instead, sea turtles may rely on senses other than hearing for interacting with their environment, such as vision (Narazaki et al. 2013) and magnetic orientation (Avens and Lohmann 2003; Putman et al. 2015). As such, it is unlikely that the temporary loss of hearing sensitivity in a sea turtle would affect its fitness (i.e., survival or reproduction) if sea turtles are exposed at TTS threshold sound levels. It is possible that sea turtles use acoustic cues such as waves crashing, wind, vessel and/or predator noise to perceive the environment around them. If such cues increase survivorship (e.g.,



aid in avoiding predators, navigation), temporary loss of hearing sensitivity may affect individual sea turtle fitness. TTS of sea turtles is expected to only last for several days following the initial exposure (Moein et al. 1994). Given this short period of time, and that sea turtles are not known to rely heavily on acoustic cues, we do not anticipate single TTS exposures would have long-term effects on the health or reproductive capacity of individual sea turtles.

Model results for sea turtle behavioral threshold distances range from 7 to 82 m (22 to 269 ft) for vibratory piling of foundations (Table 37). Because these are relatively short distances and the proposed shutdown zone of 100 m extends beyond the maximum distance, the potential for exposure to sound above the behavioral threshold for vibratory pile driving of foundations is highly unlikely for sea turtles because animals would have to remain in the immediate vicinity of pile driving activities, meaning behavioral effects from vibratory pile driving are discountable.

Model results for distances to the sea turtle behavioral threshold from impact pile driving (Table 37) range from 742 to 2,146 m (2,434 to 7,041 ft). Estimated exposures resulting from impact pile driving to sound at or above the behavioral threshold are in Table 39, the greatest was for loggerhead sea turtles at 5,764 individuals total for 2024 and 2025, because of higher loggerhead densities than other sea turtles in the project area. Total estimates across the two years for other turtle species were 215 for leatherback sea turtles, 203 for Kemp's ridley sea turtles, and 8 for leatherback sea turtles.

Studies reporting behavioral reactions of sea turtles to underwater sounds are limited, and, of those that are available, most have been conducted in a laboratory or caged setting. Potential behavioral effects may include altered submergence patterns, startle responses (e.g., diving, swimming away), short-term displacement of feeding or migrating activity, and a temporary stress response, if animals are present within the ensonified area (Samuel et al. 2005; USGS and NSF 2011). Lenhardt (1994) demonstrated that avoidance reactions of sea turtles in captivity were elicited when the animals were exposed to low frequency tones. There is no evidence to suggest that any behavioral response would persist beyond the duration of the sound exposure, which could be up to approximately 184 min for impact pile driving for both foundations. For migrating sea turtles, it is unlikely that this temporary disturbance, which would likely result in a change in swimming direction, would have long-term effects on an animal. Resting sea turtles are expected to resume resting once they escape the noise. Foraging sea turtles would resume foraging once suitable forage is located outside the area of noise.

Behavioral disturbances can happen at lower levels of sound exposure than for TTS, so it is reasonable to assume TTS requires being in closer proximity to the sound source. The behavioral threshold ranges use the SPL metric, a root mean-square sound pressure level based on the acoustic energy produced by a single hammer strike on the pile. As stated, TTS ranges based on the SEL<sub>24h</sub> metric require accumulation of acoustic energy for the full duration of the pile installation. Based on the distances in Table 37, it appears sea turtles would reach a TTS SEL<sub>24h</sub> threshold level of sound before reaching the behavioral threshold level of sound, which seems counter to the assumption of closer, more intense, exposure although the duration of time for the cumulative TTS metric makes the distance not comparable to the SPL distance. Exposure at a greater distance than the behavioral threshold (less intense sound) can lead to TTS (a more intense effect), but it takes an extensively longer time to achieve.

Based on the distances to PTS, TTS, and behavioral thresholds, exposure of green, Kemp's ridley, loggerhead and leatherback sea turtles to sound levels that produce injury, temporary hearing loss or measurable behavioral change may occur as a result of pile driving activities, particularly impact pile driving.

## Atlantic Sturgeon

Modeled results for the distance ranges to the acoustic thresholds for fish (see Section 7.1) provided in Table 40 resulting from the various modeled impact and vibratory pile driving scenarios of the WTG and OSS foundations. Atlantic sturgeon in the action area are expected to weigh more than two grams; therefore, the thresholds for below two grams are not applicable.

**Table 40. Maximum modeled distances (m) to physical injury and behavioral thresholds to fish ( $\geq 2$  g) from impact and vibratory pile driving during installation of the WTG and OSS foundations with 10 dB noise mitigation.**

Scenario	Installation Method	Injury (Lpk)	Injury (SEL <sub>12h</sub> )	Behavior (SPL)
WTG Monopile 1 - Standard Installation	Impact	445	4,501	15,010
	Vibratory	NA <sup>1</sup>	NA <sup>1</sup>	903
WTG Monopile 2 - Hard-to-drive Installation	Impact	445	5,085	15,010
	Vibratory	NA <sup>1</sup>	NA <sup>1</sup>	903
WTG Monopile 3 - One Standard and One Hard-to-drive	Impact	445	5,880	15,010
	Vibratory	NA <sup>1</sup>	NA <sup>1</sup>	903
OSS Foundation	Impact	94	2,959	5,530
	Vibratory	NA <sup>1</sup>	NA <sup>1</sup>	393

dB = decibel; Lpk = peak sound pressure level in units of dB referenced to 1 micropascal; OSS = offshore substation; SEL<sub>12h</sub> = sound exposure level over 12 hours in units of dB referenced to 1 micropascal squared second; SPL = root-mean-square sound pressure level in units of dB referenced to 1 micropascal; WTG = wind turbine generator. NA = Not Applicable. Source: Dominion Energy 2022

<sup>1</sup> NMFS does not have physical injury thresholds for non-impulsive sources, except tactical sonar.

The potential for Atlantic sturgeon exposure to the peak sound pressure level above the injury threshold is less than 500 m. The cumulative threshold for injury is up to 5.9 km but requires that Atlantic sturgeon stay within the area with sound above that level for the duration of the pile driving in an installation day. The distance to the behavioral criteria level of sound goes just past 15 km.

As discussed in Section 5.9, Atlantic sturgeon move in the spring from saltwater to estuaries. Estuaries provide foraging opportunities for subadult and adult Atlantic sturgeon, in addition to providing access to spawning habitat. Atlantic sturgeon reverse direction in the fall, moving back into the marine environment for the winter. Atlantic sturgeon are not likely to be in the ocean portion of the action area during the time period beginning in May and continuing into October when the foundation pile driving would be occurring (Kahn 2023, unpublished manuscript), meaning sturgeon are unlikely to be exposed to noise from pile driving.

The lack of exposure to underwater sound above the thresholds for physical injury or potential behavioral disturbance makes the effects from goal post pile driving discountable for Atlantic sturgeon.

### 7.3.2 Vessel Strike

Vessel collisions are a known source of injury and mortality for ESA-listed species, see discussion in the Vessel Traffic section of the Environmental Baseline (Section 6.5). As noted, there may be vessel transit associated

with the action from Canada or Europe, but we do not have enough detail to thoroughly analyze the consequences. However, after considering the risk that these vessel trips may pose to ESA-listed species that may occur outside the US EEZ, we have determined that these species fall into two categories: (1) species that are not known to be vulnerable to vessel strike and therefore, we would not expect a project vessel to strike an individual regardless of the location of the vessel; or (2) species that may generally be vulnerable to vessel strike but outside the US EEZ, co-occurrence of project vessels and individuals of those ESA-listed species are expected to be extremely unlikely due to the seasonal distribution and dispersed nature of individuals in the open ocean, and intermittent presence of project vessels. These factors make it extremely unlikely that there would be any effects to ESA-listed species from the operation of project vessels outside the EEZ. The following consideration of potential vessel strike is organized by species group (i.e., whales, sea turtles and Atlantic sturgeon) because the risk factors and effectiveness of strike avoidance measures are different for each species group.

### **Whales**

Studies of vessel strike impacts on whales found that a greater rate of mortality and serious injury to large whales correlates with greater vessel speed at the time of a ship strike (Laist et al. 2001; Vanderlaan and Taggart 2007 as cited in Aerts and Richardson 2008). Vessels transiting at speeds >10 knots present the greatest potential collision hazard (Jensen and Silber 2004; Silber et al. 2009). Vanderlaan and Taggart (2007) demonstrated that, between vessel speeds of 8.6 and 15 knots, the probability of a lethal vessel strike increases from 21% to 79%. In assessing records with known vessel speeds, Laist et al. (2001) found a direct relationship between the occurrence of a whale strike and the speed of the vessel involved in the collision. The authors concluded that most deaths occurred when a vessel was traveling in excess of 24.1 km/h (14.9 mph; 13 knots [kn]).

It is reasonable to consider the increase in vessel traffic resulting from the CVOW-C project would pose an increased risk in vessel strike to ESA-listed cetaceans, but several factors result in our determination that any hypothetical increase in vessel strike will not occur. There are measures in place to manage vessel speed to reduce strike risk to NARWs and measures incorporated into the proposed action designed to reduce the likelihood of striking ESA-listed cetaceans more broadly, such as monitoring via PSOs visually and PAM, maintaining separation distances, and speed restrictions.

In an effort to reduce the likelihood and severity of fatal collisions with NARWs, NMFS established vessel speed restrictions in specific locations, primarily at key port entrances, and during certain times of the year; these areas are referred to as Seasonal Management Areas (SMA). A 10-knot speed restriction applies to vessels 65 ft and greater in length operating within any SMA (73 FR 60173, October 10, 2008). As noted above, NMFS published proposed modifications to these regulations that would increase the scope of the speed restrictions in 2022 (87 FR 46921; August 1, 2022).

In the 2008 regulations, NMFS established a Dynamic Management Area (DMA) program whereby vessels are requested, but not required, to either travel at 10 knots or less or route around locations when certain aggregations of NARWs are detected outside SMAs. These temporary protection zones are triggered when three or more whales are visually sighted within 2-3 miles of each other outside of active SMAs. The size of a DMA is larger if more whales are present. A DMA is a rectangular area centered over whale sighting locations and encompasses a 15-nautical mile buffer surrounding the sightings' core area to accommodate the whales' movements over the DMA's 15-day lifespan. The DMA lifespan is extended if three or more whales are sighted within 2-3 miles of each other within its bounds during the second week the DMA is active. Only verified sightings are used to trigger or extend DMAs; however, DMAs can be triggered by a variety of sources, including dedicated surveys, or reports from mariners.

Acoustically triggered Slow Zones were implemented in 2020 to complement the visually triggered DMAs. The protocol for the current acoustic platforms that are implemented in the Slow Zone program specify that 3 upcalls must be detected (and verified by an analyst) to consider NARWs as “present” or “detected” during a specific time period. Acknowledging that visual data and acoustic data differ, experts from NMFS’ NARW Northeast Implementation Team, including the Northeast Fisheries Science Center and Woods Hole Oceanographic Institute staff, developed criteria for accepting detection information from acoustic platforms. To indicate NARW presence acoustically (and be used for triggering notifications), the system must meet the following criteria: (1) evaluation has been published in the peer-reviewed literature, (2) false detection rate is 10% or lower over daily time scales, and (3) missed detection rate is 50% or lower over daily time scales. Acoustically triggered Slow Zones extend approximately 20 nm from the detection source (87 FR 46921). Consistent with visual triggered DMAs, acoustically triggered Slow Zones are active for 15 days when NARWs are detected and can be extended with additional detections.

Conn and Silber (2013) assessed when the vessel restrictions were and were not in effect, and estimated the speed restrictions required by the ship strike rule reduced total ship strike mortality by 80 to 90%. In 2020, NMFS published a report evaluating the conservation value and economic and navigational safety impacts of the 2008 NARW vessel speed regulations. The report found that the level of mariner compliance with the speed rule increased to its highest level (81%) from 2018 to 2019. In most SMAs, more than 85% of vessels subject to the rule maintained speeds under 10 knots, but, in some portions of SMAs, mariner compliance is low, with rates below 25% for the largest commercial vessels outside four ports in the southeast. Evaluations of vessel traffic in active SMAs revealed a reduction in vessel speeds over time, even during periods when SMAs were inactive. An assessment of the voluntary DMA program found limited mariner cooperation that fell well short of levels reached in mandatory SMAs. The report examined AIS-equipped vessel traffic (<65 ft in length, not subject to the rule) in SMAs, in the four New England SMAs, more than 83% of all <65 ft vessel traffic transited at 10 knots or less, while in the New York, Delaware Bay, and Chesapeake SMAs, less than 50% of transit distance was below 10 knots. The southern SMAs were more mixed with 55-74% of <65 ft vessel transit distance at speeds under 10 knots (NMFS 2020a). The majority of AIS-equipped <65 ft. vessel traffic in active SMAs came from four vessel types: pleasure, sailing, pilot, and fishing vessels (NMFS 2020a).

There is a Mid-Atlantic SMA near the entrance to the Chesapeake Bay, which is relevant to the project area and would apply for project vessels traveling to Norfolk, Port of Virginia, the base port to support construction and operations. All vessels 65 ft or longer that transit the SMA from November 1 – April 30 each year (the period when NARW abundance is greatest) must operate at 10 knots or less. Most of the project vessels for CVOW-C are 65 ft or longer in length (see Table 4).

Measures required by BOEM for the project (see Appendix A, Copy of Table 1-7) will require project vessels of all sizes transiting between port and the lease area/cable corridors to operate at 10 knots or less between November 1 and April 30. Additionally, vessels of all sizes will be required to reduce speeds to 10 knots or less in any SMA, DMA, or Slow Zone, regardless of time of year.

In rulemaking, NMFS has concluded, based on the best available scientific evidence, that a maximum speed of 10 knots, measured as “speed over ground,” in certain times and locations, is the most effective and practical approach to reducing the threat of ship strikes to NARWs. A 10-knot speed restriction is likely to reduce the risk to other whale species. Substantial evidence (e.g., Jensen and Silber 2003; Kelley et al. 2020; Laist et al. 2001; Vanderlaan and Taggart 2007) indicates that vessel speed is an important factor affecting the likelihood and lethality of whale/vessel collisions. The speed restrictions provide a considerable reduction in risk of vessel strike because it both provides for greater opportunity for a whale to evade the vessel but also greater opportunity for vessels to notice a whale and make evasive maneuvers in time to avoid a collision.

In previous MMPA authorizations for OSW, NMFS OPR has required and proposing to require for CVOW-C, that, in order for vessels traveling between the lease area and the project port facilities to go over 10 knots, a PAM system must be deployed in the transit corridor and the lease area. A semi-permanent acoustic network comprising near real-time bottom mounted and/or mobile acoustic monitoring platforms will be installed such that confirmed NARW detections are regularly transmitted to a central information portal and disseminated through the project communication network. The transit corridor and OWA will be divided into action zones and detections of NARWs, or a whale that cannot be identified as other than a NARW, in an action zone would trigger a slow-down to 10 knots or less in the respective zone for the following 12 hours. Each subsequent detection would trigger a 12-hour reset. This condition will apply to areas or times of year not already covered by the speed reduction requirements in place for SMAs and DMAs.

Measures will be in place to maximize the likelihood that during all times of the year and across various conditions, if a whale is in the vicinity of a project vessel, the whale can be detected and the captain/operator can be notified to take action to avoid a strike (such as slowing down further and/or altering course). Vessel operators and crews will receive protected species identification training that covers species' identification, as well as making observations in good and bad weather. All vessel operators and crews must maintain a vigilant watch for all marine mammals and slow down, stop their vessel, or alter course (as appropriate) regardless of vessel size, to avoid striking any marine mammal. During any vessel transits within or to/from the CVOW-C project area, such as for crew transfers, an observer would be stationed at the best vantage point of the vessel(s) to ensure that the vessel(s) are maintaining the appropriate separation distance from marine mammals. A PSO or crew lookout must be posted during all times a vessel is underway (transiting or surveying) to monitor for listed species. During the vessel transit, these lookouts will have no other duty than to monitor for listed species and, if one is sighted, communicate to the vessel captain to slow down and take measures to avoid the sighted animal. Visual observers will also be equipped with alternative monitoring technology (e.g., devices for night vision, infrared and thermal imaging) for periods of low visibility (e.g., darkness, rain, fog, etc.). At all times, the lookout will be monitoring for presence of whales and ensuring that the vessel stays at least 500 m away from any NARW or unidentified large whale. If any whale is detected within 500 m of the vessel, speed will be reduced to less than 10 knots; if any NARW is observed within any distance from the vessel, speed will be reduced to less than 10 knots.

Year-round, all vessel operators will monitor WhaleAlert, US Coast Guard VHF Channel 16, and the NMFS Right Whale Sighting Advisory System (RWSAS) for the presence of NARWs once every 4-hour shift during project-related activities. The PSO monitoring teams for all activities will also monitor these systems no less than every 12 hours. If a vessel operator is alerted to a NARW detection within the project area, they will immediately convey this information to the PSO teams. All vessel operators must check for information regarding mandatory or voluntary ship strike avoidance (DMAs/Slow Zones and SMAs) and daily information regarding right whale sighting locations. Active monitoring of right whale sightings information provides situational awareness for monitoring of NARWs in the area of vessel activities.

In summary, despite the increase in vessel traffic that will result from the proposed action, because of the multi-faceted measures that will be in place, particularly the vessel speed restrictions and extensive monitoring measures, we expect that any ESA-listed whale that may be in the path of a project vessel will be detected with enough time to allow for vessel operators to avoid any such whales. Based on the best available information on the risk factors associated with vessel strikes of large whales (e.g., vessel speed), and the measures required to reduce risk, the probability that any project vessel will strike an ESA-listed whale during any phase of the proposed project is expected to be low. Thus, we consider vessel strike of ESA-listed whales to be extremely unlikely to occur and, therefore, discountable.

## Sea Turtles

Sea turtles are vulnerable to vessel collisions because they regularly surface to breathe, and often rest at or near the surface. Therefore, the sea turtle species found in the action area are at risk of vessel strikes.

Hazel et al. (2007) examined vessel strike risk to green sea turtles and suggested that sea turtles may habituate to vessel sound and are more likely to respond to the sight of a vessel rather than the sound of a vessel, although both may play a role in eliciting responses (Hazel et al. 2007). Regardless of what vessel-associated stressor turtles are responding to, they only appear to show responses (avoidance behavior) at approximately 10 m or closer (Hazel et al. 2007). This is a concern because faster vessel speeds have the potential to result in more serious injuries (Work et al. 2010). Although sea turtles can move quickly, Hazel et al. (2007) concluded that, at vessel speeds above 4 km/hour (2.1 knots), vessel operators cannot rely on turtles to actively avoid being struck. Thus, sea turtles are not considered to reliably move out of the way of vessels moving at speeds greater than 2.1 knots.

Stranding networks that keep track of sea turtles that wash up dead or injured have consistently recorded vessel propeller strikes, skeg (a section of a vessel's keel) strikes, and blunt force trauma as a cause or possible cause of death (Chaloupka et al. 2008). Vessel strikes can cause permanent injury or death from bleeding or other trauma, paralysis and subsequent drowning, infection, or inability to feed. Much of what has been documented about recovery from vessel strikes on sea turtles has been inferred from observation of individual animals for some duration of time after a strike occurs (Hazel et al. 2007; Lutcavage et al. 1997). In the U.S., the percentage of strandings that were attributed to vessel strikes increased from approximately 10% in the 1980s to 20.5% in 2004 (USFWS and NMFS 2007).

Vessel strike has been identified as a threat in recovery plans prepared for all sea turtle species in the action area. As described in the Recovery Plan for loggerhead sea turtles (NMFS and USFWS 2008), propeller and collision injuries from boats and ships are common in sea turtles. From 1997 to 2005, 14.9% of all stranded loggerheads in the U.S. Atlantic and Gulf of Mexico were documented as having sustained some type of propeller or collision injuries, although it is not known what proportion of these injuries were post or ante-mortem. The proportion of vessel-struck sea turtles that survive is unknown. In some cases, it is not possible to determine whether documented injuries on stranded animals resulted in death or were post-mortem injuries. However, the available data indicate that post-mortem vessel strike injuries are uncommon in stranded sea turtles. Based on data from off the coast of Florida, there is good evidence that, when vessel strike injuries are observed as the principle finding for a stranded turtle, the injuries were both ante-mortem and the cause of death (Foley et al. 2019). Foley et al. (2019) found that the cause of death was vessel strike or probable vessel strike in approximately 93% of stranded turtles with vessel strike injuries. Sea turtles found alive with concussive or propeller injuries are frequently brought to rehabilitation facilities; some are later released and others are deemed unfit to return to the wild and remain in captivity. Sea turtles in the wild have been documented with healed injuries so at least some sea turtles survive without human intervention.

### *Exposure Analysis*

In order to determine the potential for vessel strike of sea turtles from project-related vessel traffic, we first gathered reports of sea turtle strandings in the action area with evidence of impacts known to occur from vessel strikes (e.g., propeller scars, blunt trauma). We then looked for data to assess vessel traffic in the area going in and out of the Chesapeake Bay, to and from the ocean inlet in VA. The relation of total traffic and amount of sea turtle strikes is used to infer a vessel strike rate for sea turtles in the area. We then estimated the amount of annual vessel trips from project construction and operations to understand how much the traffic to and from the

Chesapeake Bay will increase because of the project. The expected project traffic increase is used to estimate potential vessel strikes of turtles from project vessels.

We queried the NMFS' Sea Turtle Stranding and Salvage Network (STSSN) database for records of sea turtles with injuries consistent with vessel strike (recorded as definitive vessel and blunt force trauma in the database) from 2013 to 2022 for areas of Virginia that included Norfolk, the lower Chesapeake Bay and in the vicinity of the ocean inlet. We selected this geographic area because it represents the waters that will be transited by project vessels traveling to/from the lease area/cable corridors and facilities in the Port of Virginia. The results from this query are presented in Table 41.

**Table 41. Records of sea turtles with vessel strike and blunt force trauma injuries from 2013 to 2020 in Virginia.**

Sea turtle	Loggerhead	Kemp's Ridley	Green	Leatherback
Record Range	23-51	13-23	0-6	0-3
Average	41.7	17.2	2.5	0.8
Percent of total records	67.0%	27.7%	4.0%	1.3%
93% of annual average <sup>a</sup>	39	16	2	1

<sup>a</sup>Adjustment based on Foley et al. 2019

There was a total of 622 records that resulted from the query, for an average of 62.2 cases a year over the 10-year span, which is similar to the average reported by the Virginia Aquarium & Marine Science Center Strandings Program of 62.3 sea turtle strandings per year in Virginia waters due to boat strikes from 2009-2014 (Barco et al. 2015). The majority (~ 87%) were dead strandings. The reports in Barco et al. (2015) by sea turtle species were 73.3% were loggerhead, 20.3% Kemp's ridley, 3.5% green, and 2.9% leatherback. The relative proportion of cases by sea turtle species was also similar between the 2009-2014 time series and the 2013-2020 time series, with the majority being loggerheads, followed by Kemp's ridley, and much less for greens and leatherbacks. Because the 2013-2020 time series includes more recent data, we use the yearly average and sea turtle percentages from that data set for our vessel strike estimates. Based on the findings of Foley et al. (2019), vessel strike was the cause of death in 93% of strandings with indications of vessel strike. Therefore, we adjusted the records to 93% of the annual average for each species in Table 41 and rounded to the nearest whole number (see the last row in that table).

The data in Table 41 are based on observed stranding records, which represent only a portion of the total at-sea mortalities of sea turtles. Sea turtle carcasses typically sink upon death, and float to the surface only when enough accumulation of decomposition gasses cause the body to bloat (Epperly et al. 1996). To estimate unobserved vessel strike mortalities, we relied on available estimates from the literature. Based on data reviewed in Murphy (1989), only six of 22 loggerhead sea turtle carcasses tagged within the South Atlantic and Gulf of Mexico region were reported in stranding records, indicating that stranding data represent approximately 27% of at-sea mortalities. In comparing estimates of at-sea fisheries induced mortalities to estimates of stranded sea turtle mortalities due to fisheries, (Epperly et al. 1996) estimated that strandings represented 7 to 13% of all at-sea mortalities.

Based on these two studies, both of which include waters of the U.S. East Coast, stranding data likely represent 7 to 27% of all at-sea mortalities. While there are additional estimates of the percent of at-sea mortalities likely to be observed in stranding data for locations outside the action area (Koch et al. 2013; Peckham et al. 2008), we did not rely on these since stranding rates depend heavily on beach survey effort, current patterns, weather, and seasonal factors among others, and these factors vary greatly with geographic location (Hart et al. 2006).

Thus, based on the mid-point between the lower estimate provided by Epperly et al. (1996) of 7%, and the upper estimate provided by Murphy (1989) of 27%, we assume that the STSSN stranding data represent approximately 17% of all at sea mortalities. This estimate closely aligns with an analysis of drift bottle data from the Atlantic Ocean by Hart et al. (2006), which estimated that the upper limit of the proportion of sea turtle carcasses that strand is approximately 20%.

To estimate the annual average vessel strike mortalities corrected for unobserved vessel strike mortalities, we adjusted our calculated total presumed vessel mortality with the detection value of 17%. In using the 17% correction factor, we assume that all sea turtle species and at-sea mortalities are equally likely to be represented in the STSSN dataset. That is, sea turtles killed by vessel strikes are just as likely to strand or be observed at sea and be recorded in the STSSN database (i.e., 17%) as those killed by other activities, such as interactions with fisheries, and the likelihood of stranding once injured or killed does not vary by species. The resulting adjusted number of vessel strike mortalities for each species is in Table 42.

**Table 42. Sea turtles vessel strike mortalities from 2013 to 2020 in Virginia, corrected for estimate of unobserved cases.**

Sea turtle	Loggerhead	Kemp’s Ridley	Green	Leatherback
Corrected Average	229	94	12	6

A Port Access Route Studies (PARS) report by the USCG (2023) included a traffic analysis conducted by the USCG Navigation Center. It evaluated annual trends relating to the quantity, characteristics, and routes of the vessels transiting the mouth of the Chesapeake Bay entrance. The entrance is delineated as a line from Cape Charles Light to Cape Henry Light. Data for the traffic analysis was gathered from vessel Automatic Identification System (AIS) archives and was analyzed for three years. Vessels recorded as crossing the Chesapeake Bay entrance, inbound or outbound, totaled 12,192 for 2017, 15,947 for 2018, and 16,811 for 2019. The average for the three years was 14,983 vessel transits and we used this to characterize the vessel traffic that is occurring prior to the construction and operations of the CVOW-C project for our analysis.

Based on the information provided in the construction vessel table (Table 4), project schedule (Figure 2) and description of vessel activity during the proposed operations and maintenance (Section 3.3.1), annual estimates of project-related vessel transits were made (Table 43). The estimated annual project vessel transits were used to determine a percent increase over the total of 14,983 average annual vessel transits occurring through the entrance of the Chesapeake Bay without the project (Table 43). The percentage increase in vessel traffic was then used to estimate how many more sea turtles could be impacted from vessel strike (Table 44), considering the corrected average annual sea turtle stranding mortalities attributed to vessel strike prior to the project in Table 42.

**Table 43. Annual project vessel transits and percent increase in Chesapeake Bay entrance transits.**

Construction year	2023	2024	2025	2026	2027	Annual O&M
Project vessel transits	624	2,596	3,193	816	126	94
% increase in Chesapeake entrance transits	4.2 %	17.3%	21.3%	5.4%	0.8%	0.6%



The formula used to generate the estimate of project vessel strikes over the construction and decommissioning periods is annual baseline sea turtle species strike mortalities multiplied by the percent increase in project phase traffic multiplied by the years of the project phase). Estimates in Table 44 include the five years of vessel traffic information provided for the proposed project, along with 2 years of decommissioning, which was described as the same as expected for vessel usage during project installation, so a doubling of years 2024 and 2025. The estimates also include 33 years of O&M, at the rate of 0.6% increase in annual vessel traffic for each year of O&M.

**Table 44. Estimates of sea turtles impacted by vessel strike.**

Loggerhead	Kemp's Ridley	Green	Leatherback	Project year
10	4	0	0	2023
40	16	2	1	2024
49	20	3	1	2025
12	5	1	0	2026
2	1	0	0	2027
40	16	2	1	1st year decommissioning
49	20	3	1	2nd year decommissioning
47	19	2	1	33 years of O&M
249	101	13	5	Total

The totals in Table 44 (bottom row) span 40 years. These estimates assume a sea turtle mortality is the result of a strike. The years with the greatest number of vessel transits, 2024 and 2025, have the greatest number of estimated vessel strikes for sea turtles. The majority of the estimates over the 40-year period are for loggerhead turtles, 249 total, which is indicative of the species being the most abundant sea turtle species in the action area. The next highest total is for Kemp's ridley sea turtles, 101. We calculated only 13 total vessel strikes for green sea turtles and 5 for leatherbacks.

There are a number of proposed measures designed to minimize the potential for strike of a protected species that will be implemented over the life of the project. These include the use of look outs and slowing down to 4 knots if a sea turtle is sighted within 100 m of the operating vessel's forward path, and, if a sea turtle is sighted within 50 m of the forward path of the operating vessel, the vessel operator must shift to neutral when safe to do so and then proceed away from the individual at a speed of 4 knots or less. Vessel captains/operators will also avoid transiting through areas of visible jellyfish aggregations or floating *Sargassum* lines or mats. While we expect that these measures will help to reduce the risk of vessel strike of sea turtles, individual sea turtles can be difficult to spot from a moving vessel at a sufficient distance to avoid strike due to their low-lying appearance and size. With this information in mind, we expect that the risk reduction measures that are part of the proposed action will reduce collision risk overall but will not eliminate that risk. We are not able to quantify any reduction in risk that may be realized and expect that any reduction in risk may be relatively small.

In summary, we anticipate vessel strike will occur as a result of project construction, operation, and decommissioning and that strike will result in mortality of the individual sea turtles struck by a vessel. Based on density estimates, loggerhead sea turtles are the most likely to be struck followed by Kemp's ridley sea turtles.

## Atlantic Sturgeon

Atlantic sturgeon are known to be struck and killed by vessels in rivers and in estuaries adjacent to spawning rivers and vessel strike of sturgeon has been reported for the James River in Virginia (Balazik et al. 2012a). Dead Atlantic sturgeon wash up around Virginia Beach<sup>20</sup> and Norfolk<sup>21</sup>, VA with signs of vessel strike; e.g., deep cuts, or severed head, tail or fins. The seasonal movement of Atlantic sturgeon from the ocean into the Chesapeake Bay in spring and then into spawning rivers, and the return trip in fall to overwinter back in the marine environment, is likely when the greatest risk of exposure to vessel strike occurs.

### *Exposure Analysis*

The Sturgeon Salvage Program<sup>22</sup> is a network run by NMFS to help conserve Atlantic and shortnose sturgeon. Information regarding deceased sturgeon that wash up on riverbanks and ocean beaches is sent to NMFS through this network. Using data from the reports received through the Sturgeon Salvage Program network, we estimated Atlantic sturgeon vessel strike that could occur from the project vessel transits.

We analyzed reports of dead Atlantic sturgeon from the VA portion of the Chesapeake Bay. Reports had notes of obvious slashes typical of vessel propellers and often seemed to be from large propellers, as opposed to cuts that may be observed from small recreational vessels.

Areas near river mouths and in the vicinity of the ocean inlet were included, but we did not include reports from locations farther upriver; for example, the Newport News area was included due to the Port of Virginia facilities located there, but we did not include Jamestown and farther upriver. Upriver locations receive large commercial vessels, such as for shipping, but are more narrow and may pose a different type of vessel strike risk than the river mouths and lower Chesapeake Bay. Also, project vessels are not expected to transit upriver. We tallied the reports for 2015 through 2020 to get an average annual Atlantic sturgeon vessel strike mortality for the area we analyzed, see Table 45.

**Table 45. Reports of dead Atlantic sturgeon attributed to vessel strike in the Chesapeake Bay, VA.**

Year	2015	2016	2017	2018	2019	2020	Average
Reports	12	6	5	8	9	13	9

Several studies have noted that reporting of deceased Atlantic sturgeon is likely not representative of all of the cases of vessel strike that occurs; therefore, the actual rate of lethal vessel strike is underestimated (Balazik et al. 2012a; Brown and Murphy 2010; Fox et al. 2020). The Balazik et al. (2012a) study of Atlantic sturgeon on the James River, VA, estimated that 31% (5 out of 16) deceased sturgeon released in the river were eventually reported. However, the carcass reporting rate from the Balazik et al. (2012a) study likely underestimated the number of unobserved mortalities. We base this on the following: the study occurred over a short time (approximately 4 weeks) in a single year, the sample size was small (16 deployments), and the researchers were actively searching for the carcasses, which is different from opportunistic sightings and receiving reports from the public.

A newer study by Fox et al. (2020) from Delaware State University in partnership with the USFWS and Delaware Natural Resources, estimated Atlantic sturgeon carcass reporting rates for the Delaware River and

<sup>20</sup> <https://chesapeakebaymagazine.com/endangered-dinosaur-fish-washing-up-in-virginia-beach/>

<sup>21</sup> <https://www.wtkr.com/2018/07/15/sturgeon-fish-found-on-norfolk-beach>

<sup>22</sup> <https://www.fisheries.noaa.gov/new-england-mid-atlantic/endangered-species-conservation/report-stranded-injured-or-dead-sturgeon>

Estuary. A total of 168 carcasses were released for the study seasonally over two years, providing a greater sample size and temporal distribution than previous studies. Additionally, Fox et al. (2020) relied on multiple sources of reporting and was not based on researchers actively searching for the carcasses. Estimated reporting rates varied from 2.0% (spring 2018) to 12.5% (summer and fall 2018) with a reporting rate of 4.76% when they combined the data for all seasons over the two years (2018 and 2019) of the study. Because this is the best available information, we use the 4.76% Atlantic sturgeon carcass reporting rate to adjust the annual average reports of dead Atlantic sturgeon attributed to vessel strike in Table 45. This results in an annual average, adjusted for under-reporting, of 189 dead Atlantic sturgeon attributed to vessel strike.

The percentage increase in vessel traffic from the project (Table 43) was used to estimate the potential increase in the number of Atlantic sturgeon struck by vessels (Table 46), considering the average of 9 annual dead Atlantic sturgeon attributed to vessel strike prior to the project (Table 45). Similar to what was done for sea turtle vessel strike estimates, the formula used to generate the estimate of project vessel strikes for Atlantic sturgeon over the construction and decommissioning periods is: annual baseline Atlantic sturgeon strike mortalities multiplied by % increase in project phase traffic multiplied by years of project phase).

**Table 46. Estimates of Atlantic sturgeon impacted by vessel strike.**

Atlantic sturgeon	Project year
7	2023
33	2024
39	2025
10	2026
1	2027
33	1st year decommissioning
39	2nd year decommissioning
39	33 years of O&M
201	Total

Estimates in Table 46 include the five years of vessel traffic information provided for the proposed project, along with 2 years of decommissioning, which was described as the same as expected for vessel usage during project installation, so a doubling of years 2024 and 2025. The estimates also include 33 years of O&M at the rate of 0.6% increase in annual vessel traffic for each year of O&M.

The totals in Table 46 (bottom row) span 40 years. These estimates assume Atlantic sturgeon mortality is the result of a strike. The years with the greatest amount of vessel transits, 2024 and 2025, have the greatest amount of estimated vessel strikes for Atlantic sturgeon.

Atlantic sturgeon are listed under the ESA as five DPSs. Kazyak et al. (2021), conducted a genetic mixed stock analysis relevant to the region where project vessels will be transiting back and forth between the Chesapeake Bay and the ocean lease area that can be used to attribute portions (see DPS % in Table 47) of the vessel strikes estimates to each of the five DPSs (Table 47). The majority of the total estimates are for the New York Bight DPS, which includes sturgeon from the Hudson River, NY, and the Delaware River, DE. It is possible that a small fraction (0.7%) of Atlantic sturgeon in the area may be of Canadian origin (Kazyak et al. 2021), but they are not listed under the ESA and, at that small percentage, there would likely not be any vessel strike for Atlantic sturgeon from Canada.

**Table 47. Vessel strike estimates apportioned to Atlantic sturgeon DPSs.**

Atlantic sturgeon DPS	DPS %	2023	2024	2025	2026	2027	1 year Decommissioning	2 year Decommissioning	33 years O&M	Total
New York Bight	55.3	4	18	22	6	1	18	22	22	113
Chesapeake Bay	22.9	2	8	9	2	0	8	9	9	47
South Atlantic	13.6	1	4	5	1	0	4	5	5	25
Carolina	5.8	0	2	2	1	0	2	2	2	11
Gulf of Maine	1.6	0	1	1	0	0	1	1	1	5

Because Atlantic sturgeon are fish and do not need to breathe air or surface to do so, there is a lack of opportunity to observe them from a vessel. The proposed measures for the project, such as observers, vessel speed restrictions and separation distances from protected species, are not expected to reduce the risk of vessel strike to Atlantic sturgeon.

#### 7.4 Summary of Adverse Effects

The implementation of the action, particularly pile driving using an impact hammer and vessel traffic during project construction, operation, and decommissioning, is expected to result in the take of ESA-listed whales, sea turtles, and fish.

##### 7.4.1 Pile-Driving

During the two years, 2024 and 2025, of pile driving for installation of WTG and OSS foundations, we estimate that PTS of 2 sei and 7 fin whales could occur (Table 36). We also estimate that behavioral harassment and/or TTS of 202 fin, 12 NARW, 5 sei, and 6 sperm whales (Table 36). We estimate that PTS of 1,214 Northwest Atlantic Ocean DPS loggerhead, 44 Kemp's ridley, 46 North Atlantic DPS green, and 2 leatherback sea turtles could occur as a result of OSS and WTG foundation installation (Table 39). We also estimate behavioral harassment and/or TTS of 5,764 Northwest Atlantic Ocean DPS loggerhead, 203 Kemp's ridley, 215 North Atlantic DPS green, and 8 leatherback sea turtles (Table 39).

##### 7.4.2 Vessel Strike

We estimate that vessel strike associated with the operation of project vessels during construction, operation, and decommissioning over the 40-year project timeframe will result in the mortality of 249 loggerhead, 101 Kemp's ridley, 13 green, and 5 leatherback sea turtles (Table 44); and 113 New York Bight DPS, 47 Chesapeake Bay DPS, 25 South Atlantic DPS, 11 Carolina DPS, and 5 Gulf of Maine DPS Atlantic sturgeon (Table 47).

#### 7.5 Consideration of the Effects of the Action in the Context of Predicted Climate Change

In general, waters in the Mid-Atlantic are warming and are expected to continue to warm over the 33-year operational life of the CVOW-C project. However, waters in the North Atlantic Ocean have warmed more slowly than the global average or slightly cooled because of the Gulf Stream's role in the Atlantic Meridional

Overturning Circulation. Warm water in the Gulf Stream cools as it travels farther north, becomes dense, and sinks, eventually becoming cold, deep waters that travel back equatorward, spilling over features on the ocean floor and mixing with other deep Atlantic waters to form a southward current approximately 1,500 m beneath the Gulf Stream (IPCC 2021). Globally averaged surface ocean temperatures are projected to increase by approximately 0.7 °C by 2030 and 1.4 °C by 2060 compared to the 1986-2005 average (IPCC 2014), with increases of closer to 2°C predicted for the geographic area that includes the action area. Ocean acidification is also expected to increase over the life of the project (Hare et al. 2016), which may affect the prey of a number of ESA-listed species. Ocean acidification is contributing to reduced growth and the decline of zooplankton and other invertebrates that have calcareous shells (PMEL 2020).

We considered whether it is reasonable to expect ESA-listed species whose northern distribution does not currently overlap with the action area to occur in the action area over the project life due to a northward shift in distribution. We determined that it is not reasonable to expect this to occur. This is largely because water temperature is only one factor that influences species' distribution. Even with warming waters, we do not expect hawksbill sea turtles to occur in the WDA because there will still not be any sponge beds or coral reefs that hawksbills depend on and are key to their distribution (NMFS and USFWS 2013a). We also do not expect giant manta ray or oceanic whitetip shark to occur in the WDA. Oceanic whitetip shark is a deepwater species (typically in depths greater than 184 m) that occurs beyond the shelf edge on the high seas (Young et al. 2018). Giant manta ray also occur in deeper, offshore waters and occurrence in shallower nearshore waters is coincident with the presence of coral reefs that they rely on for important life history functions (Miller and Klimovich 2017). Smalltooth sawfish do not occur north of Florida. Their life history depends on shallow estuarine habitats fringed with vegetation, usually red mangroves (Norton et al. 2012); such habitat does not occur in the WDA and would not occur even with ocean warming over the course of the proposed action. As such, regardless of the extent of ocean warming that may be reasonably expected in the action area over the life of the project, the habitat will remain inconsistent with habitats used by ESA-listed species that currently occur south of the lease area. Therefore, we do not anticipate that any of these species will occur in the lease area over the life of the proposed action.

We also considered whether climate change will result in changes in the use of the action area by Atlantic sturgeon or sea turtles and ESA-listed whales considered in this consultation. In a climate vulnerability analysis, Hare et al. (2016) concluded that Atlantic sturgeon are relatively invulnerable to distribution shifts. Given the extensive range of the species along nearly the entire U.S. Atlantic Coast and into Canada, it is unlikely that Atlantic sturgeon would shift out of the action area over the life of the project. If there were shifts in the abundance or distribution of sturgeon prey, it is possible that use of the lease area by foraging sturgeon could become more or less common. However, even if the frequency and abundance of use of the lease area by Atlantic sturgeon increased over time, we would not expect different effects to Atlantic sturgeon than those considered in this Opinion based on the current distribution and abundance of Atlantic sturgeon in the action area.

Use of the action area by sea turtles is driven, at least in part by, sea surface temperature, with sea turtles generally leaving the WDA in late fall and returning mid-spring due to colder water temperatures. An increase in water temperature could result in an expansion of the time of year that sea turtles are present in the action area and could increase the frequency and abundance of sea turtles in the action area. However, even with a 2°C increase in water temperatures, winter and early spring mean sea surface temperatures in the WDA are still likely to be too cold to support sea turtles. In the lease area, mean sea surface temperatures currently drop below 15°C (59°F) starting in November and back above that starting in May (Dominion Energy 2002). Therefore, any expansion in annual temporal distribution in the action area is expected to be small and on the order of days or potentially weeks, but not months. Any changes in distribution of prey would also be expected to affect

distribution and abundance of sea turtles, and that could be a negative or positive change. Based on the available information, we expect that any increase in the frequency and abundance of use of the lease area by sea turtles due to increases in mean sea surface temperature would be small. Regardless of this, we would not expect different effects to sea turtles than those considered in this Opinion. Further, given that any increase in frequency or abundance of sea turtles in the action area is expected to be small, we do not expect there to be an increase in risk of vessel strike above what has been considered based on current known distribution and abundance.

The distribution, abundance and migration of baleen whales reflects the distribution, abundance and movements of dense prey patches (e.g., copepods, euphausiids or krill, amphipods, shrimp), which have been linked to oceanographic features affected by climate change (Learmonth et al. 2006). Changes in plankton distribution, abundance, and composition are closely related to ocean climate, including temperature. Changes in conditions may directly alter where foraging occurs by disrupting conditions in areas typically used by species, and can result in shifts to areas not traditionally used that have lower quality or lower abundance of prey.

Climate change is unlikely to affect the frequency or abundance of sperm or sei whales in the action area. The species' rarity in the WDA is expected to continue over the life of the project because the area is inward of the shelf edge and shallower than the open ocean deepwater areas typically frequented by sei and sperm whales. Two of the significant potential prey species for fin whales in the lease area are sand lance and Atlantic herring. Hare et al. (2016) concluded that climate change is likely to negatively impact sand lance and Atlantic herring but noted that there was a high degree of uncertainty in this conclusion. The authors noted that higher temperatures may decrease productivity and limit habitat availability. A reduction in small schooling fish such as sand lance and Atlantic herring in the WDA could result in a decrease in the use of the area by foraging fin whales. The distribution of copepods in the North Atlantic, including in the WDA, is driven by a number of factors that may be impacted by climate change. Record et al. (2019) suggest that recent changes in the distribution of North Atlantic right whales are related to recent rapid changes in climate and prey and note that, while right whales may be able to shift their distribution in response to changing oceanic conditions, the ability to forage successfully in those new habitats is also critically important. Warming in the deep waters of the Gulf of Maine is negatively impacting the abundance of *Calanus finmarchicus*, a primary prey for right whales. *C. finmarchicus* is vulnerable to the effects of global warming, particularly on the Northeast U.S. Shelf, which is in the southern portion of its range (Grieve et al. 2017). Grieve et al. (2017) used models to project *C. finmarchicus* densities into the future under different climate scenarios considering predicted changes in water temperature and salinity. Based on their results, by the 2041–2060 period, 22 – 25% decreases in *C. finmarchicus* density are predicted across all regions of the Northeast U.S. shelf. A decrease in abundance of right whale prey in the WDA could be expected to result in a similar decrease in abundance of right whales in the WDA over the same time scale; however, whether the predicted decline in *C. finmarchicus* density is great enough to result in a decrease in right whale presence in the action area over the life of the project is unknown.

Based on the available information, it is difficult to predict how the use of the action area by fin, right, and other large whales may change over the operational life of the project. Changes in habitat may be related to a northward shift in distribution of prey species due to warming waters. There could be a decreased abundance of prey in the WDA. It is also possible that reductions in prey in other areas will result in more frequent foraging in the WDA over time. However, this would require shifts in distribution of prey species to the WDA or other changes in the species targeted by large whales that are not reasonably certain to occur. Based on the information available at this time, it seems most likely that the use of the WDA by large whales will decrease or remain stable. As such, we do not expect any changes in abundance or distribution that would result in different effects of the action than those considered in the *Effects of the Action* section of this Opinion. To the extent new

information on climate change, listed species, and their prey becomes available in the future indicating that the effects of the action may have changed, reinitiation of this consultation may be necessary.

## 8 CUMULATIVE EFFECTS

“Cumulative effects” are those effects of future state or private activities, not involving Federal activities, that are reasonably certain to occur within the action area of the Federal action subject to consultation (50 C.F.R. §402.02). Future Federal actions that are unrelated to the proposed action are not considered in this section because they require separate consultation pursuant to section 7 of the ESA. It is important to note that, while there may be some overlap, the ESA definition of cumulative effects is not equivalent to the definition of “cumulative impacts” as described in the CVOW-C DEIS. Under NEPA, “cumulative effects...are the impact on the environment resulting from the incremental impact of the action when added to other past, present, and reasonably foreseeable future actions.” While the effects of past and ongoing Federal projects for which consultation has been completed are evaluated in both the NEPA and ESA processes (Section 6.0 *Environmental Baseline*), reasonably foreseeable future actions by Federal agencies must be considered (see 40 CFR 1508.7) in the NEPA process but not the ESA section 7 process.

We reviewed the list of cumulative impacts identified by BOEM in the CVOW-C DEIS and determined that most (e.g., other future offshore wind energy development activities, EMF from submarine power cables, new cable emplacement and maintenance, biological/fisheries monitoring surveys, and Federal fisheries use and management) do not meet the ESA definition of cumulative effects because we expect that, if any of these activities were proposed in the action area, or proposed elsewhere yet were to have future effects inside the action area, they would require at least one Federal authorization or permit and would, therefore, be subject to the ESA section 7 consultation requirements. BOEM identifies global climate change as a cumulative impact in the DEIS. Because global climate change is not a future state or private activity, we do not consider it a cumulative effect for the purposes of this consultation. Rather, future state or private activities reasonably certain to occur and contribute to climate change’s effects in the action area are relevant. However, given the difficulty of parsing out climate change effects due to past and present activities from those of future state and private activities, we discussed the effects of the action in the context of climate change in the Effects of the Action section (Section 7).

It is important to note that, because any future offshore wind project will require section 7 consultation, these future wind projects do not fit within the ESA definition of cumulative effects. However, in each successive consultation, the effects on listed species of other offshore wind projects under construction or completed would be considered to the extent they influence the status of the species and environmental baseline in the action area for each consultation according to the best available scientific and commercial information. We presented information on the South Fork, Vineyard Wind, Ocean Wind 1, Revolution Wind, and Empire Wind projects in the Environmental Baseline of this Opinion for this reason.

During this consultation, we searched for information on future state, tribal, local, or private (non-Federal) actions reasonably certain to occur in the action area or have effects in the action area. We did not find any information about non-Federal actions other than what has already been described in the Environmental Baseline, most of which we expect would continue into the future. Non-Federal activities that we are reasonably certain will continue to have effects in the action area include recreational fisheries, fisheries authorized by states, use of the action area by private vessels, commercial and private anthropogenic noise sources, and coastal development authorized by state and local governments. Any coastal development that requires a Federal authorization, inclusive of a permit from the USACE, would require future section 7 consultation and would not be considered a cumulative effect.

An increase in the above activities could similarly increase the magnitude of their effects on ESA-listed species. For many of the activities and associated threats identified in the environmental baseline, and other unforeseen threats, the magnitude of increase and the significance of any anticipated effects remain unknown. The best scientific and commercial data available provide little specific information on any long-term effects of these potential sources of disturbance on populations of ESA-listed species. We do not have any information to indicate that effects of these activities over the life of the proposed action will have different effects than those considered in the Status of the Species and Environmental Baseline sections of this Opinion, inclusive of how those activities may contribute to climate change. We expect aspects described in the Environmental Baseline will continue to impact ESA-listed resources into the foreseeable future.

## 9 INTEGRATION AND SYNTHESIS

The *Integration and Synthesis* section is the final step in our assessment of the effects and corresponding risk posed to ESA-listed species and designated critical habitat affected as a result of implementing the proposed action. In this section, we add the *Effects of the Action* (Section 7) with the *Status of the Species* (Section 5), the *Environmental Baseline* (Section 6), and the *Cumulative Effects* (Section 8), to formulate the agency's biological opinion as to whether the proposed action "reasonably would be expected, directly or indirectly, to reduce appreciably the likelihood of both the survival and recovery of an ESA-listed species in the wild by reducing its numbers, reproduction, or distribution" (50 CFR §402.02; the definition of "jeopardize the continued existence of"). The purpose of this analysis in this Opinion is to determine whether the action is likely to jeopardize the continued existence of the NARW, fin, sei, or sperm whales, the five DPSs of Atlantic sturgeon, and sea turtles: loggerhead Northwest Atlantic DPS, green North Atlantic DPS, leatherback and Kemp's ridley.

Below, for the listed species that may be adversely affected by the proposed action (i.e. those species affected by the action and for which *all* effects are not extremely unlikely (discountable) and/or insignificant) we summarize the status of the species and consider whether the action will result in reductions in reproduction, numbers, or distribution of these species. We then consider whether any reductions in reproduction, numbers, or distribution resulting from the action would reduce appreciably the likelihood of both the survival and recovery of these species, consistent with the definition of "jeopardize the existence of" (50 C.F.R. §402.02) for purposes sections 7(a)(2) and 7(b) of the Federal Endangered Species Act and its implementing regulations.

In addition, we use the following guidance and regulatory definitions related to survival and recovery to guide our jeopardy analysis. In the NMFS/USFWS Section 7 Handbook, for the purposes of determining whether jeopardy is likely, survival is defined as, "the species' persistence as listed or as a recovery unit, beyond the conditions leading to its endangerment, with sufficient resilience to allow for the potential recovery from endangerment. Said in another way, survival is the condition in which a species continues to exist into the future while retaining the potential for recovery. This condition is characterized by a species with a sufficient population, represented by all necessary age classes, genetic heterogeneity, and number of sexually mature individuals producing viable offspring, which exists in an environment providing all requirements for completion of the species' entire life cycle, including reproduction, sustenance, and shelter." Recovery is defined in regulation as, "Improvement in the status of listed species to the point at which listing is no longer appropriate under the criteria set out in Section 4(a)(1) of the Act." 50 C.F.R. §402.02

### 9.1 North Atlantic Right Whales

The endangered NARW is in decline in the western North Atlantic (Pace et al. 2017; Pace et al. 2021) and experiencing an unusual mortality event (Daoust et al. 2018). The population estimate in the most recent Stock Assessment Report (Hayes et al. 2022b) is 368 individuals (95% CI: 403-424) based on information through



November 2019. The most recent SAR (Hayes et al. 2023) uses photographic data up through December 2021 to produce a median abundance value ( $N_{est}$ ) of 338 individuals (95% CI: 325–350) and a minimum population estimate of 332. Modeling indicates that low female survival, a male-biased sex ratio, and low calving success are contributing to the population's current decline (Pace et al. 2017). Entanglement and vessel strikes are currently understood to be the most significant threats to NARWs and that continues to occur in U.S. and Canadian waters. Entanglement in fishing gear appears to have had substantial health and energetic costs that affect both survival and reproduction of right whales (van der Hoop et al. 2017a). Typical of small populations, NARWs have low genetic diversity and hence the ability to adapt and be resilient to future perturbations is likely limited (Hayes et al. 2018). The death of any individual is expected to have measurable effects in the projections on its population status, trend, and dynamics.

As explained in the Effects section (Section 7) in this Opinion, the only adverse effects to NARWs expected to result from the CVOW-C project are temporary behavioral disturbance and/or temporary threshold shift in hearing from exposure to pile driving noise during installation of WTG and OSS foundations. We consider these adverse effects as harassment under the ESA. Up to 6 individual NARWs a year, for a total of 12 individuals over two years (Table 36), exposed to noise above the behavioral threshold from foundation pile driving noise. No mortality or permanent injury (auditory or other) is expected from exposure to any aspect of the proposed action during the construction, operations, or decommissioning phases of the project.

The proposed activities include several measures expected to reduce the occurrence and intensity of noise exposure from foundation pile-driving operations. Foundation pile driving installation would only occur between May and October, which avoids the winter and spring seasons when NARW presence is expected to be greater. Monitoring includes daily review of NARW sighting databases. The PSOs will visually monitor from the foundation construction vessel and from PSO monitoring vessels. A real-time PAM system will be used to supplement visual monitoring and PAM has been shown to be particularly effective when used in conjunction with visual observations, increasing the overall capability to detect marine mammals (Van Parijs et al. 2021). Pre-clearance monitoring and shutdowns during foundation installation will occur at any distance from the source if a NARW is detected visually or acoustically. The use of a soft-start creates an opportunity for a lower level sound to serve as an aversive stimulus and allow for the whale to start moving away from the source before more intense sound is emitted at levels that could cause hearing loss (Southall et al. 2007b; Southall et al. 2016).

There would likely be an energetic cost associated with any temporary displacement or change in migratory route and disruption of a single foraging event, but, unless disruptions occur over long durations or over subsequent days, which we do not expect, we do not anticipate this movement to be consequential to the animal over the long-term (Southall et al. 2007a). Similarly, the disruption of a single foraging event lasting for a few hours on a single day is not expected to affect the health of an animal, even an animal in poor condition. The energetic consequences of the evasive behavior and delay in resting or foraging are not expected to affect any individual's ability to successfully obtain enough food to maintain their health, or impact the ability of any individual to make seasonal migrations or participate in future breeding or calving. Stress responses are also anticipated to occur as a result of noise exposure and the accompanying behavioral response. However, the available literature suggests these acoustically induced stress responses will be of short duration (similar to the duration of exposure), and not result in a chronic increase of stress that could result in physiological consequences to the animal (Southall et al. 2007a). Given the intermittent periods of time during which elevated noise from foundation pile driving could be experienced, we do not anticipate long duration exposures to occur, and we do not anticipate the associated stress of exposure to result in significant costs to affected individuals. As such, we do not expect any reductions in reproduction or overall number of NARWs.

Short-term behavioral responses or TTS from potential exposure to WTG and OSS foundation pile driving noise experienced by a NARW is not anticipated to have any lingering consequences to the individual's fitness. Considering the lack of significant impacts to individual NARW fitness, we do not expect any reduced capacity for survival or future reproductive output. Any effects to NARW distribution will be limited to short-term alterations to normal movements by individuals to avoid disturbing levels of noise. Any effects from exposure to pile driving noise will not change the overall distribution of NARW. Thus, we do not expect an appreciable reduction in the survival of NARWs in the wild as a result of this project.

The goal of the 2005 Recovery Plan for the NARW (NMFS 2005) is to promote the recovery of NARWs to a level sufficient to warrant their removal from listing under the ESA. The intermediate recovery goal is to reclassify the species from endangered to threatened. The recovery strategy identified in the Recovery Plan focuses on reducing or eliminating deaths and injuries from anthropogenic activities, such as shipping and commercial fishing operations. The recovery plan includes the following downlisting criteria, the achievement of which would demonstrate significant progress toward full recovery:

- 1) The population ecology (range, distribution, age structure, and gender ratios, etc.) and vital rates (age-specific survival, age-specific reproduction, and lifetime reproductive success) of right whales are indicative of an increasing population;
- 2) The population has increased for a period of 35 years at an average rate of increase equal to or greater than 2% per year;
- 3) None of the known threats to NARWs (summarized in the 5 listing factors) are known to limit the population's growth rate; and
- 4) Given current and projected threats and environmental conditions, the right whale population has no more than a 1% chance of quasi-extinction in 100 years.

Population growth rates are crucial to species recovery. No consequences are anticipated to NARW population growth rates from this OSW energy development project. Thus, the proposed action will not appreciably reduce the likelihood of recovery in the wild for NARWs.

## 9.2 Fin Whales

Rangewide, there are over 100,000 fin whales occurring primarily in the North Atlantic Ocean, North Pacific Ocean, and Southern Hemisphere (Cooke 2018b). Fin whales off the eastern US are classified by NMFS as the Western North Atlantic stock (Donovan 1991; Hayes et al. 2019; NMFS 2010c). Estimated abundance for the Western North Atlantic Stock of 6,802 individuals fin whales ( $N_{\min}=5,573$ ) is the sum of the 2016 NOAA shipboard and aerial surveys and the 2016 Canadian Northwest Atlantic International Sightings Survey, although there is not enough information available to conduct a population trend analysis (Hayes et al. 2022a). Similar to NARWs, contemporary leading threats for fin whales include entanglement in fishing gear and vessel strikes. The species' overall large population size may provide some resilience to current threats, but population trends are largely unknown.

As explained in the Effects section (Section 7) in this Opinion, the only adverse effects to fin whales from the CVOW-C project are expected to result from exposure to pile driving noise during installation of WTG and OSS foundations. It was estimated that over the course of two years (see Table 36), up to 202 fin whales could experience temporary behavioral disturbance and/or TTS in hearing considered as harassment under the ESA, and up to 7 fin whales could experience effects of PTS, which is an auditory injury and therefore considered

harm under the ESA. No mortality or permanent non-auditory injury is expected for fin whales from any aspect of the proposed action during the construction, operations, or decommissioning phases of the project.

The seven fin whales exposed to sound above the PTS threshold are not expected to experience severe or serious effects of PTS because the large pre-clearance zone reduces the chance that a fin whale will be in proximity of PTS level noise when pile driving commences. The soft-start at a lower level sound allows time for the whale to start moving away from the source before more intense sound is emitted. If a fin whale happens to approach the pile driving activities, the shutdown zone will be implemented to reduce the duration and intensity of noise exposure. The PTS threshold distance of concern is a cumulative threshold (peak pressure is small or not applicable) and it is unlikely a whale will stay within proximity of the noise for the entire duration needed for PTS to be realized. If PTS does occur for a fin whale, it is not expected to impair more than a minor portion of the individual's hearing range, and not impact the ability to continue life functions that would be expected to reduce the whale's survival. This determination is consistent with NMFS OPR's conclusion in the proposed ITA that if PTS hearing impairment occurs from exposure to pile driving noise, it is most likely that the affected animal would lose a few decibels in its hearing sensitivity, which, given the limited impact to hearing sensitivity, is not likely to meaningfully affect its ability to forage and communicate with conspecifics.

If fin whales are exposed to underwater noise above the behavioral threshold, it could result in displacement of individuals from a localized area around a pile (up to 8.9 km; Table 34). Displacement could be temporary for the duration of activity, not quite 5 hours per 24-hour period for both vibratory and impact pile driving of two monopiles per day and less than 3 hours if just one monopile. The OSS foundation take longer to pile drive, not quite 9 hours per day for both vibratory and impact pile driving of two pin piles, but the distance to the behavioral threshold level of sound (up to 3.6 km) is less than half the distance compared to the monopiles and there are only 12 pin piles total to be installed over 6 days. There is evidence indicating whales resume normal behavior quickly after the cessation of sound exposure (Goldbogen et al. 2013; Melcon et al. 2012). If effects of TTS occur for fin whales from foundation pile driving noise, it is recoverable and any temporary loss of hearing sensitivity can be regained within minutes or up to a few days of exposure (Finneran 2015), and is not expected to affect the health of any whale or its ability to migrate or forage (Southall et al. 2007a). We do not expect a change in the overall distribution of fin whales because of exposure to pile driving noise.

There would likely be an energetic cost associated with any temporary disruption in foraging or displacement in migratory path, but short-term disruptions are not anticipated to be consequential to the animal over the long-term (Southall et al. 2007a). The energetic consequences of the evasive behavior are not expected to affect any individual's ability to successfully obtain enough food to maintain their health, or impact the ability of any individual to make migrations or participate in future breeding or calving. Stress responses are also anticipated with each of these instances of disruption. However, the available literature suggests these acoustically induced stress responses will be of short duration (similar to the duration of exposure), and not result in a chronic increase in stress that could result in physiological consequences to the animal (Southall et al. 2007a). Given the intermittent periods of time during which elevated noise from foundation pile driving could be experienced, we do not anticipate the associated stress of exposure to result in significant costs to affected individuals. As such, we do not expect any reductions in reproduction or overall number of fin whales. Thus, we do not expect an appreciable reduction in the survival of fin whales in the wild as a result of this project.

The 2010 Recovery Plan (NMFS 2010c) for fin whales included two criteria for consideration for reclassifying the species from endangered to threatened:

1. Given current and projected threats and environmental conditions, the fin whale population in each ocean basin in which it occurs (North Atlantic, North Pacific and Southern Hemisphere) satisfies the risk

analysis standard for threatened status (has no more than a 1% chance of extinction in 100 years) and has at least 500 mature, reproductive individuals (consisting of at least 250 mature females and at least 250 mature males) in each ocean basin. Mature is defined as the number of individuals known, estimated, or inferred to be capable of reproduction. Any factors or circumstances that are thought to substantially contribute to a real risk of extinction that cannot be incorporated into a Population Viability Analysis will be carefully considered before downlisting takes place; and,

2. None of the known threats to fin whales are known to limit the continued growth of populations. Specifically, the factors in 4(a)(1) of the ESA are being or have been addressed: A) the present or threatened destruction, modification or curtailment of a species' habitat or range; B) overutilization for commercial, recreational or educational purposes; C) disease or predation; D) the inadequacy of existing regulatory mechanisms; and E) other natural or manmade factors.

Population growth rates are crucial to species recovery and no consequences are anticipated to fin whale population growth rates from this OSW energy development project. Thus, the proposed action will not appreciably reduce the likelihood of recovery in the wild for fin whales.

### 9.3 Sei Whales

Sei whales occur in all major oceans and sei whales in the western North Atlantic are a part of the Nova Scotia stock. Based on survey data collected from Halifax, Nova Scotia, to Florida between 2010 and 2013, it is estimated that there are approximately 6,292 sei whales ( $N_{\min}=3,098$ ) in the Nova Scotia stock (Palka et al. 2017). This is considered the best available data for the Nova Scotia stock of sei whales because it was derived from surveys covering the largest proportion of the range (Halifax, Nova Scotia to Florida), during the season when they are the most prevalent in U.S. waters (in spring), using only recent data (2010–2013), and correcting aerial survey data for availability bias (Hayes et al. 2022b). However, as described in Hayes et al. (2022b) (the most recent stock assessment report), there is considerable uncertainty in this estimate, and there are insufficient data to determine population trends for the Nova Scotia stock of sei whales (Hayes et al. 2021). As described in the Status of the Species, a robust estimate of worldwide abundance is not available. The most recent abundance estimate for the North Atlantic is an estimate of 10,300 whales in 1989 (Cattanach et al. 1993 as cited in NMFS 2011b). The species' abundance overall may provide some resilience to current threats, for example, in the western North Pacific, it is estimated that there are 35,000 sei whales (Cooke 2018a); however population trends are largely unknown. Similar to the other baleen whales in this Opinion, contemporary leading threats for sei whales include entanglement in fishing gear and vessel strikes.

As explained in the Effects section (Section 7) in this Opinion, the only adverse effects to sei whales from the CVOW-C project are expected to result from exposure to pile driving noise during installation of WTG and OSS foundations. It was estimated that, over the course of two years (see Table 36), up to 5 sei whales could experience temporary behavioral disturbance and/or TTS in hearing consider harassment under the ESA, and up to 2 sei whales could experience effects of PTS which is an auditory injury and, therefore, considered harm under the ESA. No mortality or permanent non-auditory injury is expected for sei whales from any aspect of the proposed action during the construction, operations, or decommissioning phases of the project.

The two sei whales estimated to be exposed to sound above the PTS threshold are not expected to experience severe or serious effects of PTS because of the measures to minimize the effects of sound that are part of the proposed action. The soft-start at a lower level sound allows time for the whale to start moving away from the source before more intense sound is emitted. If a sei whale happens to approach the pile driving activities, the shutdown zone will be implemented to reduce the duration and intensity of noise exposure. The PTS threshold

distance of concern is a cumulative threshold (peak pressure is small or not applicable) and it is unlikely a whale will stay within proximity of the noise for the entire duration needed for PTS to be realized. If PTS does occur for a sei whale, it is not expected to impair more than a minor portion of the individual's hearing range, which should not impact the ability to continue life functions that would be expected to reduce the whale's survival. This determination is consistent with NMFS OPR's conclusion in the proposed ITA that, if PTS hearing impairment occurs from exposure to pile driving noise, it is most likely that the affected animal would lose a few decibels in its hearing sensitivity, which, given the limited impact to hearing sensitivity, is not likely to meaningfully affect its ability to forage and communicate with conspecifics.

If sei whales are exposed to underwater noise above the behavioral threshold, it could result in displacement of individuals from a localized area around a pile (up to 8.9 km; Table 34). Displacement could be temporary for the duration of activity, not quite 5 hours per 24-hour period for both vibratory and impact pile driving of two monopiles per day and less than 3 hours if just one monopile. The OSS foundation take longer to pile drive, not quite 9 hours per day for both vibratory and impact pile driving of two pin piles, but the distance to the behavioral threshold level of sound (up to 3.6 km) is less than half the distance compared to the monopiles and there are only 12 pin piles total to be installed over 6 days. There is evidence indicating whales resume normal behavior quickly after the cessation of sound exposure (Goldbogen et al. 2013; Melcon et al. 2012). If effects of TTS occur for sei whales from foundation pile driving noise, it is recoverable and any temporary loss of hearing sensitivity can be regained within minutes or up to a few days of exposure (Finneran 2015), and is not expected to affect the health of any whale or its ability to migrate or forage (Southall et al. 2007a). We do not expect a change in the overall distribution of sei whales because of exposure to pile driving noise. In addition, as described in the previous sections, we do not expect any temporary energetic costs or stress responses will result in a reduction in numbers or reproduction of sei whales. Thus, we do not expect an appreciable reduction in the survival of sei whales in the wild as a result of this project.

The most recent five-year review for sei whales (NMFS 2021g) concluded that recovery criteria outlined in the sei whale recovery plan (NMFS 2011b) do not reflect the best available and most up-to-date information on the biology of the species. The 5-Year review states that currently, there are insufficient data to undertake an assessment of the sei whale's present status due to a number of uncertainties and unknowns for this species, including: (1) lack of scientifically reliable population estimates for the North Atlantic and Southern Hemisphere; (2) lack of comprehensive information on status and trends; (3) existence of critical knowledge gaps; and (4) emergence of potential new threats. Thus, further research is needed to fill critical knowledge gaps.

Despite the need for a revised recovery plan, population growth rates are crucial to species recovery. No consequences are anticipated to sei whale population growth rates from this OSW energy development project. Thus, the proposed action will not appreciably reduce the likelihood of recovery in the wild for sei whales.

#### **9.4 Sperm Whales**

The most recent global sperm whale population estimate is 360,000 whales (Whitehead 2009). There are no reliable estimates for sperm whale abundance across the entire North Atlantic Ocean. However, the North Atlantic stock is estimated to consist of 4,349 individuals ( $N_{\min}=3,451$ ), (Hayes et al. 2019).

Similar to the other baleen whales in this Opinion, contemporary leading threats for sperm whales include entanglement in fishing gear and vessel strikes. The species' abundance overall may provide some resilience to current threats; however, population trends are largely unknown.

As explained in the Effects section (Section 7) in this Opinion, the only adverse effects to sperm whales from the CVOW-C project are expected to result from exposure to pile driving noise during installation of WTG and OSS foundations. It was estimated that over the course of two years (see Table 36), up to 6 sperm whales could experience temporary behavioral disturbance and/or TTS in hearing that would be considered harassment under the ESA. No mortality or any injury is expected for sperm whales from any aspect of the proposed action during the construction, operations, or decommissioning phases of the project.

The proposed activities include measures expected to reduce the occurrence and intensity of noise exposure from foundation pile-driving operations, such as the PSOs that will monitor visually and the use of real-time PAM system to supplement visual monitoring. The pre-clearance monitoring zones and shutdown zones extend beyond the PTS threshold distances for sperm whales. The use of a soft-start creates an opportunity for a lower level sound to serve as an aversive stimulus and allow for the whale to start moving away from the source before more intense sound is emitted at levels that could cause hearing loss (Southall et al. 2007b; Southall et al. 2016).

If sperm whales are exposed to underwater noise above the behavioral threshold, it could result in displacement of individuals from a localized area around a pile (up to 8.9 km; Table 34). Displacement could be temporary for the duration of activity, not quite 5 hours per 24-hour period for both vibratory and impact pile driving of two monopiles per day and less than 3 hours if just one monopile. The OSS foundation take longer to pile drive, not quite 9 hours per day for both vibratory and impact pile driving of two pin piles, but the distance to the behavioral threshold level of sound (up to 3.6 km) is less than half the distance compared to the monopiles and there are only 12 pin piles total to be installed over 6 days. There is evidence indicating whales resume normal behavior quickly after the cessation of sound exposure (Goldbogen et al. 2013; Melcon et al. 2012). If effects of TTS occur for sperm whales from foundation pile driving noise, it is recoverable and any temporary loss of hearing sensitivity can be regained within minutes or up to a few days of exposure (Finneran 2015), and is not expected to affect the health of any whale or its ability to migrate or forage (Southall et al. 2007a). We do not expect a change in the overall distribution of sperm whales because of exposure to pile driving noise. In addition, as described Sections 9.1 and 9.2, we do not expect any temporary energetic costs or stress responses will result in a reduction in numbers or reproduction of sperm whales. Thus, we do not expect an appreciable reduction in the survival of sei whales in the wild as a result of this project.

The 2010 Recovery Plan for sperm whales (NMFS 2010d) contains downlisting and delisting criteria that may be considered for reclassifying sperm whales to threatened when all of the following have been met:

1. Given current and projected threats and environmental conditions, the sperm whale population in each ocean basin in which it occurs (Atlantic Ocean/Mediterranean Sea, Pacific Ocean, and Indian Ocean) satisfies the risk analysis standard for threatened status (has no more than a 1% chance of extinction in 100 years) and the global population has at least 1,500 mature, reproductive individuals (consisting of at least 250 mature females and at least 250 mature males in each ocean basin). Mature is defined as the number of individuals known, estimated, or inferred to be capable of reproduction. Any factors or circumstances that are thought to substantially contribute to a real risk of extinction that cannot be incorporated into a Population Viability Analysis will be carefully considered before downlisting takes place; and,
2. None of the known threats to sperm whales is known to limit the continued growth of populations. Specifically, the factors in 4(a)(1) of the ESA are being or have been addressed: A) the present or threatened destruction, modification or curtailment of a species' habitat or range; B) overutilization for commercial, recreational or educational purposes; C) disease or predation; D) the inadequacy of existing regulatory mechanisms; and E) other natural or manmade factors.

As for the other whale species considered in this Opinion, population growth rates are crucial to species recovery and no consequences are anticipated to sperm whale population growth rates from this OSW energy development project. The proposed action will not appreciably reduce the likelihood of recovery in the wild for sperm whales.

## 9.5 Sea turtles

Most sea turtle populations have suffered reductions from human harvesting of multiple sea turtle life stages (from eggs to adult sea turtles), degradation of beach nesting habitats, as well as bycatch in fishing industries worldwide.

As explained in the Effects section (Section 7) in this Opinion, adverse effects to sea turtles from the CVOW-C project are expected to result from exposure to pile driving noise during installation of WTG and OSS foundations and from project vessel strike. Effects to sea turtles from pile driving noise include PTS, an auditory injury considered harm under the ESA, and temporary behavioral disturbance and/or TTS, considered harassment under the ESA (see Table 39 for acoustic exposure estimates). Estimates of vessel strike for sea turtles are assumed to result in mortality (see Table 44 for vessel strike estimates).

The proposed measures for PSOs to visually monitor a pre-clearance zone and a shutdown zone are expected to reduce the occurrence and intensity of noise exposure from foundation pile-driving operations, assuming observers are able to see turtles prior to their entry into areas where sound exposure as a result of pile driving will occur. The peak sound pressure level PTS threshold distances for sea turtles are only a maximum of 10 m, but the cumulative PTS distance is out to 1.4 km, which is not completely covered by the 1,000 m clearance zone and beyond the proposed 100 m shutdown zone. Similarly for TTS, the peak sound pressure threshold distance is a maximum of 67 m but the cumulative threshold goes out to 4.8 km, beyond both the clearance zone and shutdown zones for sea turtles. The behavioral threshold distance for sea turtles is out to 2.1 km, which is also beyond the 1,000 m clearance zone and 100 m shutdown zone. These distances are also well beyond the distance to which an observer may be able to sight a sea turtle given the size of the animals. The soft-start/ramp up for foundation pile driving may provide an opportunity for a lower level sound to serve as an aversive stimulus and allow for the sea turtle to start moving away from the source before more intense sound is emitted at levels that could cause hearing loss. Distances that will be used for clearance and shutdown zones will help avoid exposure to injurious sound levels and reduce exposure intensity to sound above acoustic thresholds for sea turtles, but some level of PTS, TTS and behavioral disturbance may still occur for sea turtles.

The cumulative PTS threshold considers total estimated daily exposure, requiring a sea turtle to remain within that threshold distance over the entire duration of noise during the day of exposure to experience the effects of PTS. A sea turtle is more likely to move away, especially if perceived as an unpleasant noise, than to remain for the duration, which reduces the potential for PTS effects to occur. However, the possibility for sea turtles to experience PTS-level exposures during impact pile driving remains because the proposed clearance and shutdown zone does not fully encompass the cumulative PTS range. The 1,000 m clearance zone does cover most of the 1.4 km cumulative PTS distance, which will help reduce the probability of sea turtles in the vicinity of the pile before driving starts. The soft-start at a lower level sound allows time for sea turtles to start moving away from the source before more intense sound is emitted. The 100 m shutdown zone will reduce the intensity of noise received by sea turtles. Considering the cumulative duration of exposure needed and the mitigation measures, effects from PTS to sea turtles are expected to be rare and not severe. Sea turtles are considered to have relatively poor auditory sensitivity and are not known to rely heavily on sound for life functions or to use sound for communication (Nelms et al. 2016; Popper et al. 2014). Sea turtles may rely primarily on senses other than hearing, for interacting with their environment, such as vision (Narazaki et al. 2013) and magnetic orientation (Avens and Lohmann 2003; Putman et al. 2015). Considering the lack of acoustic stimulus

dependence for sea turtles, it is unlikely that a minor loss of hearing (partial loss at a certain frequency range) would have significant effects on its fitness and reproductive potential and will not reduce the numbers of sea turtles of each species considered in the effects analysis.

Although we do not have TTS estimates to evaluate because that exposure was not modeled for sea turtles, we expect sea turtles could be exposed to noise above the TTS threshold considering that the cumulative threshold distance extends out to 4.8 km, farther than the cumulative PTS threshold distance. Some portion of sea turtles exposed to sound from foundation impact pile driving could experience some degree of TSS, a form of auditory fatigue that is non-permanent and recoverable. Considering the cumulative duration of exposure needed and the mitigation measures previously mentioned, such as pre-clearance, shutdowns and soft-start, any effects from TTS to sea turtles are expected to be mild. Effects of TTS could potentially hinder normal sea turtle behavior and functions temporarily, but this is not expected to have any significant consequences to individual sea turtle fitness and reproductive potential, and will not reduce the numbers of sea turtles of each species considered in the effects analysis.

If sea turtles are exposed to underwater noise above the behavioral threshold, it could result in displacement of individuals from a localized area around a pile (up to 2.1 km; Table 37). Displacement would be temporary for the duration of activity, not quite 5 hours per 24-hour period for both vibratory and impact pile driving of two monopiles per day and less than 3 hours if just one monopile. The OSS foundation takes longer to pile drive, not quite 9 hours per day for both vibratory and impact pile driving of two pin piles, but the distance to the behavioral threshold level of sound is small, only up to 82 m.

Lenhardt (1994) demonstrated that avoidance reactions of sea turtles in captivity were elicited when the animals were exposed to low frequency tones. Along with avoidance, there could be short-term displacement of feeding or migrating activity, and a temporary stress response (Samuel et al. 2005; USGS and NSF 2011). There is no evidence to suggest that any behavioral response would persist beyond the duration of the sound exposure and sea turtles are expected to resume previous behaviors once the noise has stopped or they have swum out of range. Foraging sea turtles could resume foraging once suitable forage is located outside the area of noise. The energetic consequences of the evasive behavior are not expected to affect any individual's ability to successfully obtain enough food to maintain their health, or impact the ability of any individual to make migrations or participate in future breeding. Given the intermittent periods of time during which elevated noise from foundation pile driving could be experienced, we do not anticipate the associated stress of exposure to result in significant energetic or reproductive costs to affected individuals.

We do not expect reduced numbers or capacity for future reproductive output for any sea turtle species from PTS. Short-term behavioral responses or TTS from potential exposure to WTG and OSS foundation pile driving noise experienced by sea turtles is not anticipated to have any lingering consequences to the individual's fitness. We also do not expect changes in the overall distribution of any of the turtle species considered in this Opinion because of exposure to pile driving noise.

Recovery plans for the sea turtles in this opinion all cite the need to protect nesting habitat and most of them also mention protecting marine habitats. None of the proposed activities are expected to have impacts on sea turtle nesting habitat. Feeding is a main component of marine habitats for sea turtles. As described, potential disruptions of feeding by sea turtles are expected to be temporary and sea turtles are expected to be able to resume feeding in the area when the pile driving noise ceases.

In addition to sublethal impacts from acoustic stressors discussed above, mortalities are expected to occur from vessel strikes. The estimates of vessel strike for sea turtles assume mortality (see Table 44 for vessel strike estimates). It is possible that a vessel strike could just result in an injury to a sea turtle but the estimates were



based on reports of dead sea turtles. Death of an individual sea turtle would result in a reduction in their absolute population number, and would eliminate the reproductive potential it might have contributed. For a population to remain stable, sea turtles must successfully reproduce at least once over the course of their reproductive lives and at least one offspring must survive to reproduce. If the hatchling survival rate to maturity is greater than the mortality rate of the population, the loss of breeding individuals would be exceeded through recruitment of new breeding individuals from successful reproduction of the remaining sea turtles. There is general agreement that the number of nesting females provides a useful index of the species' population size and stability. Adult nesting females often account for less than 1% of total population numbers (Bjorndal et al. 2005). Vessel strike estimates are for a 40-year time span; 5 years of construction plus 33 years of operations and 2 years of decommissioning. The following subsections discuss the take estimated for each of the sea turtles species in this Opinion.

### **9.5.1 Loggerhead, Northwest Atlantic Ocean DPS**

The global abundance of nesting female loggerhead sea turtles is estimated at 43,320 to 44,560. Over 90% of loggerhead sea turtle nesting in the U.S. occurs in Florida (Ceriani et al. 2021). Using a stage/age demographic model, the adult female population size of the Northwest Atlantic Ocean DPS is estimated at 20,000 to 40,000 females, and 53,000 to 92,000 nests annually (NMFS 2009b). In 2010, there were estimated to be approximately 801,000 loggerhead turtles (greater than 30 cm in size, interquartile range of approximately 521,000–1,111,000) in the northwestern Atlantic continental shelf region based on aerial surveys (NMFS 2011a). Since 1989, the Fish and Wildlife Research Institute has coordinated the Index Nesting Beach Survey (INBS), a detailed sea turtle nesting-trend monitoring program. Witherington and others (2009) analyzed an 18-year time series (1989–2006) of INBS nest-count data and, although there appears to be a net decrease over the series, nesting on Florida Panhandle index beaches, which represent the largest nesting assemblage for this DPS, have trended upward since 2012, increasing to levels comparable to the late 1990s, with a record number of nests in 2016 (FFWCC 2018). The AMAPPS surveys and sea turtle telemetry studies conducted along the U.S. Atlantic coast in the summer of 2010 provided a preliminary regional abundance estimate of about 588,000 loggerheads along the U.S. Atlantic coast, with an interquartile range of 382,000-817,000 (NMFS 2011a). The estimate increases to approximately 801,000 (interquartile range of 521,000-1,111,000) when based on known loggerheads and a portion of unidentified sea turtle sightings (NMFS 2011a). Although there is much uncertainty in these population estimates, they provide some context for evaluating the size of the likely population of loggerheads in the Northwest Atlantic, which is an indication of the size of the Northwest Atlantic DPS.

The estimated 249 mortalities from vessel strike of loggerhead sea turtles are for a 40-year time. Mortalities were not estimated to be greater than 49 loggerhead sea turtles for any one year and, most years during the period of O&M vessel activity, may have only 1 or 2 mortalities. Considering the size estimates for Northwest Atlantic Ocean DPS population and nesting, this DPS of loggerheads is expected to be resilient to the loss of a few individual sea turtles a year. The loss of 40 individual loggerheads one year and then 49 the next year during the most active construction years is more substantial than just one or two, but this is limited to those two construction years and numbers are much lower for the majority of the time until decommissioning, which has the same estimates as the two years of construction. The decommissioning would be 35 years later and that span of time is unlikely to compound the impact from a loss of individuals during construction years. Considering estimates of several hundred thousand to possibly a million loggerheads in the northwestern Atlantic region (NMFS 2011a), the highest single year estimate of 49 loggerhead sea turtle vessel strike mortalities for any one year is a relatively small portion of the loggerheads in this population. Likewise, 249 mortalities spread out over 40 years is not expected to have a measurable effect on population-level reproduction or the trend in nesting abundance.

As previously discussed, the only adverse effects to sea turtles from the CVOW-C project besides vessel strike are from pile driving noise during installation of WTG and OSS foundations, which could affect up to 6,978 loggerhead sea turtles, mostly due to exposure to pile driving noise over the behavioral threshold but also PTS. We conclude that noise exposure will not result in a decrease in numbers or a loss of reproductive capacity or reduce the overall distribution of the species. Therefore, the proposed action is not reasonably expected to cause an appreciable reduction in the likelihood of survival in the wild of loggerhead turtles from the Northwest Atlantic DPS loggerhead sea turtles.

The criteria in the 2008 Final Recovery Plan for the Northwest Atlantic Population of Loggerheads (NMFS and USFWS 2008) focus on sustained increases in the number of nests laid and the number of nesting females protecting habitats, minimizing and managing predation and disease, and minimizing anthropogenic mortalities. As previously discussed, none of the proposed activities are expected to have a measurable effect on population-level reproduction or the trend in nesting abundance. We acknowledge there are losses of individual loggerheads expected but that the actions are not expected to have long term impacts on the future population growth of the DPS or its potential for recovery. We do not expect impacts on sea turtle nesting habitat. Feeding is a main component of marine habitats for sea turtles and as described, potential disruptions of feeding by sea turtles are expected to be temporary. The proposed action will not appreciably reduce the likelihood of recovery for Northwest Atlantic DPS of Loggerheads.

### **9.5.2 Kemp's Ridley**

Kemp's ridley sea turtles occur in the Atlantic Ocean and Gulf of Mexico, but the only major nesting site known for Kemp's ridleys is Rancho Nuevo, Mexico, where large aggregations (arribadas) have occurred, estimated at 40,000 females in 1947. The region declined significantly to 300 nesting females by the mid-80's. However, more recent nesting counts in this same region show an increase. In 2014, there were an estimated 10,987 nests and 519,000 hatchlings released from three primary nesting beaches in Mexico (NMFS and USFWS 2015a). The number of nests in Padre Island, Texas has increased over the past two decades, with one nest observed in 1985, four in 1995, 50 in 2005, 197 in 2014 (NMFS and USFWS 2015a).

The estimated 101 mortalities from vessel strike of Kemp's ridley sea turtles are for a 40-year time. Sea turtle mortalities were not estimated to be greater than 20 Kemp's ridley sea turtles for any one year, and many of the 33 years of just O&M vessel activity may only have one or zero mortalities of this species. The increased nesting trend for the species demonstrates a capacity for this population to rebound and to be resilient. The loss of 20 individual loggerheads one year and then 16 the next year are the largest annual losses, which are during the most active construction years, but numbers are significantly lower for the majority of the project until decommissioning, which has the same estimates of vessel strike mortality as the two years of construction. The decommissioning would be 35 years later and that span of time is unlikely to compound impacts to the species from vessel strike mortality during the construction years. The loss of 101 Kemp's ridley sea turtles over 40 years is not expected to have a measurable effect on population-level reproduction or the trend in nesting abundance.

As previously discussed, the only adverse effects to sea turtles from the CVOW-C project besides vessel strike are from pile driving noise during installation of WTG and OSS foundations, which could affect up to 247 Kemp's ridley sea turtles, mostly due to exposure to sound over the behavioral threshold but also due PTS. We conclude that noise exposure will not result in a decrease in numbers of reproductive capacity or reduce the overall distribution of the species. Therefore, the proposed action is not reasonably expected to cause an appreciable reduction in the likelihood of survival of Kemp's ridley sea turtles in the wild.

Priority recovery goals in the 2011 Final Bi-National (U.S. and Mexico) Revised Recovery Plan for Kemp's ridley sea turtles (NMFS et al. 2011) increasing the population size, specifically nesting females and the recruitment of hatchlings, increasing in the number of nests and preserving nesting beaches, and maintaining sufficient habitat for foraging and migration. As previously discussed, none of the proposed activities are expected to have a measurable effect on population-level reproduction or the trend in nesting abundance. We acknowledge there are losses of individual Kemp's ridley sea turtles expected but that the actions are not expected to have long term impacts on the future population growth of the species or its potential for recovery. We do not expect impacts on sea turtle nesting habitat. Potential disruptions of feeding or migrations by Kemp's ridley sea turtles are expected to be temporary. The proposed action will not appreciably reduce the likelihood of recovery for Kemp's ridley sea turtles.

### **9.5.3 Green, North Atlantic DPS**

The North Atlantic DPS of green sea turtles is the largest of the 11 green turtle DPSs with an estimated abundance of over 167,000 adult females from 73 nesting sites. All major nesting populations demonstrate long-term increases in abundance (Seminoff et al. 2015b).

The estimated 13 mortalities from vessel strike of green sea turtles are for a 40-year time. Mortalities were not estimated to be greater than 3 green sea turtles for any one year and many years, such as the 33 years of just O&M vessel activity, may only have one or zero mortalities. Considering the estimates for the North Atlantic DPS population and nesting, the loss of 13 green sea turtles over 40 years is not expected to have a measurable effect on population-level reproduction or the trend in nesting abundance.

As previously discussed, the only adverse effects to sea turtles from the CVOW-C project besides vessel strike are from pile driving noise during installation of WTG and OSS foundations, which could affect 261 green sea turtles, mostly due to exposure to noise over the behavioral threshold but also due to PTS. We conclude that noise exposure will not result in a decrease in numbers or reproductive capacity or reduce the overall distribution of the species. Therefore, the proposed action is not reasonably expected to cause an appreciable reduction in the likelihood of survival of green sea turtles in the wild.

The goals of the 1991 Recovery Plan for the U.S. population of green sea turtles in the Atlantic is (NMFS 1991) include criteria related to nesting activity, nesting habitat protection, and reduction in commercial fishing bycatch mortality. As previously discussed, none of the proposed activities are expected to have a measurable effect on population-level reproduction or the trend in nesting abundance. We acknowledge there are losses of individual green sea turtles expected but that the actions are not expected to have long term impacts on the future population growth of the species or its potential for recovery. We do not expect impacts on green sea turtle nesting habitat from the proposed action. Potential disruptions of feeding or migrations by Kemp's ridley sea turtles are expected to be temporary. The proposed action will not appreciably reduce the likelihood of recovery for North Atlantic DPS green sea turtles.

### **9.5.4 Leatherback**

Due to the scarcity of leatherback sea turtles in the project vicinity and the limited number of vessel strike-related stranding reports, the estimate of project vessel strike resulted in only 5 leatherbacks being struck over the 40-year time span of vessel strike analysis. No more than one leatherback sea turtle vessel strike mortality is expected in any year and most years would have zero vessel strike mortalities. Based on estimates calculated from nest count data, there are between 34,000 and 94,000 adult leatherbacks in the North Atlantic (TEWG 2007a). The total index of nesting female abundance for the leatherback population in the Northwest Atlantic is 20,659 females (NMFS and USFWS 2020), which is only a portion of the total population. The loss of 5

leatherback sea turtles over 40 years is not expected to have a measurable effect on the population, its reproductive capacity or nesting abundance.

As previously discussed, the only adverse effects to sea turtles from the CVOW-C project besides vessel strike are from pile driving noise during installation of WTG and OSS foundations, which could affect 10 leatherback sea turtles, mostly due to behavioral harassment. We conclude that noise exposure will not result in a decrease in numbers or reproductive capacity or reduce the overall distribution of the species. Therefore, the proposed action is not expected to cause an appreciable reduction in the survival of leatherback sea turtles in the wild.

The goals of the recovery plan for the U.S. Caribbean, Gulf of Mexico, and Atlantic (NMFS and USFWS 1992) populations of leatherback sea turtles include criteria related to increasing the adult female population, and protection for nesting and marine habitats. As previously discussed, none of the proposed activities are expected to have a measurable effect on population-level reproduction or the trend in nesting abundance. We acknowledge there are losses of a few individual leatherback sea turtles expected but that the actions are not expected to have long term impacts on the future population growth of the species or its potential for recovery. We do not expect impacts on leatherback sea turtle nesting habitat from the proposed action. Potential disruptions of feeding or migrations by leatherback sea turtles are expected to be temporary. The proposed action will not appreciably reduce the likelihood of recovery for leatherback sea turtles.

## 9.6 Atlantic sturgeon

In 2012, NMFS listed 5 DPSs of Atlantic sturgeon (Gulf of Maine, New York Bight, Chesapeake Bay, Carolina, and South Atlantic) based on low population sizes and the level of continuing threats such as degraded water quality, habitat impacts from dredging, bycatch in state and Federally-managed fisheries, and vessel strikes.

As explained in the Population Dynamics for Atlantic sturgeon (Section 5.9.2), a population estimate was derived from the NEAMAP trawl surveys that estimate an overall abundance of Atlantic sturgeon in U.S. Atlantic waters to be 67,776 fish (see table 16 in Kocik et al. 2013). Based on genetic frequencies of occurrence in the sampled area, this overall population estimate was subsequently partitioned by DPS (Table 15). However, this cannot be considered an estimate of the total number of subadults because it only considers those subadults that are of a size that are present and vulnerable to capture in commercial trawl and gillnet gear in the marine environment. The estimate also does not capture younger fish that have not made it out to the marine environment yet. Despite these limitations, this represents the best information for an overall population estimate.

As explained in the Effects section (Section 7) in this Opinion, the only adverse effects to Atlantic sturgeon from the CVOW-C project are expected to result from project vessel strike. Estimates of vessel strike for Atlantic sturgeon assume strike results in mortality (see Table 44 for vessel strike estimates). Vessel strike estimates are for a 40-year time span; 5 years of construction plus 33 years of operations and 2 years of decommissioning. It is possible that a vessel strike could just result in an injury to an Atlantic sturgeon but the estimates were based on reports of dead Atlantic sturgeon. Death of an individual Atlantic sturgeon would result in a reduction in their absolute population number, and eliminate the reproductive potential it might have contributed. For a population to remain stable, Atlantic sturgeon must successfully reproduce at least once over the course of their reproductive lives and at least one offspring must survive to reproduce. If the spawning survival rate to maturity is greater than the mortality rate of the population, the loss of breeding individuals would be exceeded through recruitment of new breeding individuals from successful reproduction of the remaining Atlantic sturgeon.

No recovery plans have been developed for Atlantic sturgeon. Population growth rates are crucial to species recovery. No consequences to Atlantic sturgeon population growth rates are anticipated from this OSW energy development project. The following subsections discuss the mortality estimated from vessel strike for each of the Atlantic sturgeon DPSs in this Opinion.

### **9.6.1 New York Bight DPS**

The estimated 113 mortalities for New York Bight DPS Atlantic sturgeon are for a 40-year time span of vessel strike. No one year was estimated to have more than 22 New York Bight DPS Atlantic sturgeon mortalities, most years, 33 years of just O&M vessel activity, may have only 1 or zero mortalities. The New York Bight DPS is expected to be the most abundant in the area and also has the largest population estimate (8,642 adults and 34,566 total; Table 15), which indicates a capacity for resilience to the loss of a few individual New York Bight DPS Atlantic sturgeon on an annual basis. The loss of 18 individual New York Bight DPS Atlantic sturgeon one year and then 22 the next year during the most active construction years is more substantial than just one a year, but this is limited to those two construction years and numbers are much lower, only one or none, for the majority of the time until decommissioning, which has the same estimates as for those two years of construction. The decommissioning would be 35 years later and that span of time is unlikely to compound the impact from those construction years. Considering it has the largest population estimate of all the Atlantic sturgeon DPSs (Table 15), the highest single year estimate of 22 New York Bight DPS Atlantic sturgeon vessel strike mortalities is a relatively small portion of the Atlantic sturgeon in this population. Likewise, the loss of 113 animals over 40 years is not expected to have a measurable effect on population-level reproduction or the trend in abundance of the New York Bight DPS, or affect distribution of the DPS.

The only adverse effect expected from the proposed action is vessel strike for the New York Bight DPS Atlantic sturgeon and it is not reasonably expected to cause an appreciable reduction in the likelihood of survival of Atlantic sturgeon from the New York Bight DPS in the wild. Similarly, the proposed action is not reasonably expected to cause an appreciable reduction in recovery in the wild for the New York Bight DPS because the loss of a small number of individuals annually will not affect trends in population growth rates.

### **9.6.2 Chesapeake Bay DPS**

The estimated 47 mortalities for Chesapeake Bay DPS Atlantic sturgeon are for the 40-year time span of vessel strike. No more than 9 mortalities are expected any single year and, for the majority of years, such as the 33 years of just O&M vessel activity, there would be zero or 1 mortality. The loss of 8 individual Chesapeake Bay DPS Atlantic sturgeon one year and then 9 the next year during the most active construction years is more substantial than just one a year, but this is limited to those two construction years and numbers are much lower, only one or none, for the majority of the time until decommissioning, which has the same estimates as for those two years of construction. The decommissioning would be 35 years later and that span of time is unlikely to compound the impact from those construction years. Considering the population estimate of the Chesapeake Bay DPS (2,203 adults and 8,811 total; Table 15), the highest single year estimate of 9 Chesapeake Bay DPS Atlantic sturgeon vessel strike mortalities is a relatively small portion of the Atlantic sturgeon in this population. Likewise, the loss of 47 Atlantic sturgeon across 40 years is not expected to have a measurable effect on population abundance or on the reproductive potential of the Chesapeake Bay DPS, or affect distribution of the DPS.

The only adverse effect expected from the proposed action is vessel strike for the Chesapeake Bay DPS Atlantic sturgeon and it is not reasonably expected to cause an appreciable reduction in the likelihood of survival of Atlantic sturgeon from the Chesapeake Bay DPS in the wild. Similarly, the proposed action is not reasonably

expected to cause an appreciable reduction in recovery in the wild for the Chesapeake Bay DPS because the loss of a small number of individuals annually will not affect trends in population growth rates.

### **9.6.3 South Atlantic DPS**

The estimated 25 mortalities for South Atlantic DPS Atlantic sturgeon are for the 40-year time span of vessel strike. No more than 5 mortalities are expected any single year and, for the many of years during O&M vessel activity, there would be no mortalities. The loss of 5 individual South Atlantic DPS Atlantic sturgeon one year and then 4 the next year during the most active construction years is limited to those two years and numbers are much lower, only one or none, for the majority of the time until decommissioning, which has the same estimates as for those two years of construction. The decommissioning would be 35 years later and that span of time is unlikely to compound the impact from those construction years. Considering it the population estimate of the South Atlantic DPS (3,728 adults and 14,911 total; Table 15), the highest single year estimate of 5 South Atlantic DPS Atlantic sturgeon vessel strike mortalities is a relatively small portion of the Atlantic sturgeon in this population. Likewise, the loss of 25 individual Atlantic sturgeon is not expected to have a measurable effect on population abundance or on the reproductive potential of the South Atlantic DPS, or affect distribution of the DPS.

The only adverse effect expected from the proposed action is vessel strike for the South Atlantic DPS and it is not reasonably expected to cause an appreciable reduction in the likelihood of survival of Atlantic sturgeon from the South Atlantic DPS in the wild. Similarly, the proposed action is not reasonably expected to cause an appreciable reduction in recovery in the wild for the South Atlantic DPS because the loss of a small number of individuals annually will not affect trends in population growth rates.

### **9.6.4 Carolina DPS**

The estimated 11 mortalities for Carolina DPS Atlantic sturgeon are for the 40-year time span of vessel strike. No more than 2 mortalities are expected any single year and during the 33 years of O&M vessel activity there would be only 2 mortalities. The loss of 2 individual South Atlantic DPS Atlantic sturgeon one year and then 2 the next year is limited to the most active construction years and then again during decommissioning, which has the same estimates as for those two years of construction. The decommissioning would be 35 years later and that span of time is unlikely to compound the impact from those construction years. Considering the population estimate of the South Atlantic DPS (339 adults and 1,356 total; Table 15), the highest single year estimate of 2 South Atlantic DPS Atlantic sturgeon vessel strike mortalities is a relatively small portion of the Atlantic sturgeon in this population. Likewise, the loss of 11 individual Atlantic sturgeon across 40 years is not expected to have a measurable effect on population abundance, or the reproductive potential, or affect distribution of the DPS.

The only adverse effect expected from the proposed action is vessel strike for the Carolina DPS and it is not reasonably expected to cause an appreciable reduction in the likelihood of survival of Atlantic sturgeon from the Carolina DPS in the wild. Similarly, the proposed action is not reasonably expected to cause an appreciable reduction in recovery in the wild for the Carolina DPS because the loss of a small number of individuals annually will not affect trends in population growth rates.

### **9.6.5 Gulf of Maine DPS**

The estimated 5 mortalities for Gulf of Maine Atlantic sturgeon are during the 40-year time span of vessel strike. No more than 1 mortality is expected any single year and during the 33 years of O&M vessel activity

there would be only 1 mortality. Considering the population estimate of the Gulf of Maine DPS (1,864 adults and 7,455 total; Table 15), the highest single year estimate of 1 Atlantic sturgeon vessel strike mortality is a very small portion of the Atlantic sturgeon in this population. Likewise, the loss of 5 individual Atlantic sturgeon across 40 years is not expected to have a measurable effect on population abundance or on the reproductive potential of the Gulf of Maine DPS, or affect distribution of the DPS.

The only adverse effect expected from the proposed action is vessel strike for the Gulf of Maine DPS and it is not reasonably expected to cause an appreciable reduction in the likelihood of survival of the Gulf of Maine DPS Atlantic sturgeon in the wild. Similarly, the proposed action is not reasonably expected to cause an appreciable reduction in recovery in the wild for the Gulf of Maine DPS because the loss of a small number of individuals annually will not affect trends in population growth rates.

## 10 CONCLUSION

After reviewing the current status of the ESA-listed species, the environmental baseline within the action area, the effects of the proposed action, and cumulative effects, it is our opinion that the proposed action is not likely to jeopardize the continued existence of the fin, sei, sperm, or NARWs or the Northwest Atlantic DPS of loggerhead sea turtles, North Atlantic DPS of green sea turtles, Kemp's ridley or leatherback sea turtles, or any of the five DPSs of Atlantic sturgeon.

NMFS has also determined that the proposed action may affect, but is not likely to adversely affect the following listed species and designated or proposed critical habitat: blue whale, Rice's whale, Gulf of Maine DPS Atlantic salmon, oceanic whitetip shark, scalloped hammerhead shark (Eastern Atlantic DPS and Central & Southwest Atlantic DPS), shortnose sturgeon, hawksbill sea turtle, giant manta ray, Gulf sturgeon and its critical habitat, NARW critical habitat, all listed DPSs Atlantic sturgeon critical habitats, Northwest Atlantic DPS loggerhead sea turtle critical habitat, proposed critical habitat for North Atlantic DPS of green sea turtles, and proposed critical habitat for Rice's whale.

## 11 INCIDENTAL TAKE STATEMENT

Section 9 of the ESA and Federal regulations pursuant to section 4(d) of the ESA prohibit the take of endangered and threatened species, respectively, without a special exemption. In the case of threatened species, section 4(d) of the ESA leaves it to the Secretary's discretion whether and to what extent to extend the statutory 9(a) "take" prohibitions, and directs the agency to issue regulations it considers necessary and advisable for the conservation of the species.

"Take" is defined as to harass, harm, pursue, hunt, shoot, wound, kill, trap, capture or collect, or to attempt to engage in any such conduct. Harm is further defined by regulation to include significant habitat modification or degradation that results in death or injury to ESA-listed species by significantly impairing essential behavioral patterns, including breeding, feeding, or sheltering. NMFS has not yet defined "harass" under the ESA in regulation, but has issued guidance on the term "harass," defining it as to "create the likelihood of injury to wildlife by annoying it to such an extent as to significantly disrupt normal behavior patterns which include, but are not limited to, breeding, feeding, or sheltering" (NMFS PD 02-110-19). We considered NMFS' definition of harassment in evaluating whether the proposed activities are likely to result in harassment of ESA-listed species. Incidental take statements serve a number of functions, including providing reinitiation triggers for all anticipated take, providing exemptions from the section 9 prohibitions against take, and identifying reasonable and prudent measures that will minimize the impact of anticipated incidental take and monitor incidental take that occurs.

When an action will result in incidental take of ESA-listed marine mammals, ESA section 7(b)(4) requires that such taking be authorized under the MMPA section 101(a)(5) before the Secretary can issue an ITS for ESA-listed marine mammals and that an ITS specify those measures that are necessary to comply with Section 101(a)(5) of the MMPA. Section 7(b)(4), section 7(o)(2), and ESA regulations provide that taking that is incidental to an otherwise lawful activity conducted by an action agency or applicant is not considered to be prohibited taking under the ESA if that activity is performed in compliance with the terms and conditions of an ITS, including those specified as necessary to comply with the MMPA, Section 101(a)(5). Accordingly, the terms of this ITS and the exemption from section 9 of the ESA become effective only upon the issuance of MMPA authorization to take the marine mammals identified here. Absent such authorization, this ITS is inoperative for ESA-listed marine mammals. As described in this Opinion, Dominion Energy/CVOW-C has applied for an MMPA ITA; a decision regarding issuance of the ITA is expected in January 2024 following issuance of the Record of Decision for the project.

The measures described below must be undertaken by the action agencies so that they become binding conditions for the exemption in section 7(o)(2) to apply. BOEM and other action agencies have a continuing duty to regulate the activity covered by this ITS. If one or more of them: (1) fails to assume and implement the terms and conditions, or (2) fails to require the project sponsor or their contractors to adhere to the terms and conditions of the ITS through enforceable terms that are added to any COP approval, grants, permits and/or contracts, the protective coverage of section 7(o)(2) may lapse. The protective coverage of section 7(o)(2) also may lapse if the project sponsor fails to comply with the terms and conditions. In order to monitor the impact of incidental take, BOEM, other action agencies, and CVOW-C must report the progress of the action and its impact on the species to us as specified in the ITS [50 CFR §402.14(i)(3)] (See U.S. Fish and Wildlife Service and National Marine Fisheries Service's Joint Endangered Species Act Section 7 Consultation Handbook (1998) at 4-49).

### **11.1 Amount or Extent of Take**

Section 7 regulations require NMFS to specify the impact of any incidental take of endangered or threatened species; that is, the amount or extent of such incidental taking on the species (50 C.F.R. §402.14(i)(1)(i)). As explained in the Effects of the Action section, we anticipate pile driving during construction to result in auditory injury (PTS) and the harassment of fin and sei whales, and DPS green, Kemp's ridley, and leatherback sea turtles. We also anticipate pile driving during construction to result in the harassment of North Atlantic right and sperm whales. We anticipate the mortality of Northwest Atlantic DPS loggerhead, North Atlantic green, Kemp's ridley, and leatherback sea turtles due to vessel strikes during construction, operation, and decommissioning phases of the project. No other sources of incidental take are anticipated.

There is no incidental take anticipated to result from EPA's proposed issuance of an Outer Continental Shelf Air Permit or the USCG's proposed issuance of a Private Aids to Navigation (PATON) authorization. We anticipate no more than the amount and type of take indicated below to result from the construction, operation, and decommissioning of the CVOW-C project as proposed for approval by BOEM and pursuant to other permits, authorizations, and approvals by BSEE, USACE, and NMFS OPR.

The methodology used to estimate the amount of take resulting from the CVOW-C activities is summarized in Section 7.4 of this opinion. The number of whales likely to be injured (PTS) or harassed (TTS and/or Behavioral Disturbance) due to exposure to pile driving noise can be found in Table 36. The number of sea turtles likely to be injured (PTS) or harassed (TTS and/or Behavioral Disturbance) due to exposure to pile driving noise can be found in Table 39. The number of sea turtles likely to be impacted and suffer mortality from vessel strike can be found in Table 44. The number of Atlantic sturgeon likely to be impacted and suffer mortality from vessel strike can be found in Table 46 and Table 47.



## 11.2 Reasonable and Prudent Measures

We have determined the following RPMs are necessary and appropriate to minimize, document, and report the impacts of incidental take of threatened and endangered species that occurs during implementation of the proposed action:

1. Effects to ESA-listed species must be minimized during pile driving.
2. Effects to, or interactions with, ESA-listed Atlantic sturgeon, whales, and sea turtles must be documented during all phases of the proposed action, and all incidental take must be reported to NMFS GARFO.
3. Plans must be prepared that describe the implementation of activities or monitoring protocols for which the details were not available at the time this consultation was completed. All required plans must be submitted to NMFS GARFO with sufficient time for review, comment, and concurrence.
4. BOEM and BSEE must exercise their authorities to assess and ensure compliance with the implementation of measures to avoid, minimize, monitor and report incidental take of ESA-listed species during activities described in this Opinion. On-site observation and inspection must be allowed to gather information on the implementation of measures, and the effectiveness of those measures, to minimize and monitor incidental take during activities described in this Opinion, including its Incidental Take Statement.

## 11.3 Terms and Conditions

To be exempt from the prohibitions of section 9 of the ESA, the Federal action agencies (BOEM, BSEE, USACE, and NMFS OPR, each consistent with their own legal authority) – and CVOW-C (the lessee and applicant), must comply with the following terms and conditions (T&C), which implement the RPMs above. These include the take minimization, monitoring, and reporting measures required by the section 7 regulations (50 C.F.R. §402.14(i)). These terms and conditions are non-discretionary; that is, if the Federal agencies and/or CVOW-C fail to ensure compliance with these terms and conditions and the RPMs they implement, the protective coverage of section 7(o)(2) may lapse.

1. Establish a shutdown zone for sea turtles extending 500 m around any pile being installed during impact pile driving of WTG and OSS foundations. BOEM must ensure that there is sufficient PSO coverage to reliably document sea turtle presence within the 500 m shutdown zone. In the event that a PSO detects a sea turtle within the 500 m clearance zone, the shutdown procedures described as part of the proposed action must be implemented.
2. To implement the requirements of RPM 1 and 2 for ESA-listed whales, to the extent that the final MMPA ITA requires additional measures from those in the proposed ITA (which are incorporated into the proposed action) to minimize effects of pile driving on ESA-listed whales, CVOW-C must comply with those measures. To facilitate implementation of this requirement:
  - a. BOEM must require, through an enforceable condition of their approval of CVOW-C's Construction and Operations Plan, that CVOW-C comply with any measures in the final MMPA ITA that are revised from, or in addition to, measures included in the proposed ITA, which already have been incorporated into the proposed action.
  - b. NMFS OPR must ensure compliance with all mitigation measures as prescribed in the final ITA. We expect this will be carried out through NMFS OPR's review of plans and monitoring reports, including interim and final SFV reports, submitted by CVOW-C over the life of the MMPA ITA and taking any responsive action within its statutory and regulatory authority it deems necessary to ensure compliance based on the foregoing review.
  - c. The USACE must review the final MMPA ITA as issued by NMFS OPR and determine if an amendment or revision is necessary to the permit issued to CVOW-C by USACE to incorporate

any new or revised measures for pile driving or related activities addressed in the USACE permit, to ensure compliance with any measures in the final MMPA ITA that are revised from, or in addition to, measures included in the proposed ITA, which have been incorporated into the proposed action; and, if necessary, exercise its regulatory authority to make appropriate amendments or revisions.

3. To implement the requirements of RPM 1, the following related to sound field verification (SFV) must be implemented by BOEM, BSEE, USACE, and/or CVOW-C. The purpose of SFV and the steps outlined here are to ensure that CVOW-C does not exceed the distances to the injury or behavioral harassment threshold (Level A and Level B harassment respectively) for ESA-listed marine mammals, the injury or behavioral harassment thresholds for sea turtles, or the injury or behavioral disturbance thresholds for Atlantic sturgeon that are identified in this Opinion and that underpin the effects analysis, exposure analysis and our determination of the amount and extent of incidental take exempted in this ITS, including the determination that no incidental take is anticipated. The measures outlined here are based on the expectation that CVOW-C's initial pile driving methodology and sound attenuation measures will result in noise levels that do not exceed the identified distances (as modeled assuming 10 dB attenuation) but, if that is not the case, provide a step-wise approach for modifying operations and/or modifying or adding sound attenuation measures that can reasonably be expected to avoid exceeding those thresholds prior to the next pile being driven.
  - a. Consistent with the measures incorporated into the proposed action, BOEM, BSEE, and USACE must require and CVOW-C must implement Sound Field Verification (SFV) on at least the first three monopiles installed (see also T&C 8.d. below) in accordance with the additional requirements specified here. If any of the SFV measurements from any of the piles indicate that the distance to any isopleth of concern is greater than those modeled assuming 10 dB attenuation (see Table 34, Table 37, and Table 40), before the next pile is installed CVOW-C must implement the following measures as applicable:
    - i. Identify and propose for review and concurrence: additional, modified, and/or alternative noise attenuation measures or operational changes that present a reasonable likelihood of reducing sound levels to the modeled distances (e.g., if the pile was installed with a single bubble curtain and a near field sound attenuation device, add a second bubble curtain or if the pile was installed with a double bubble curtain without a near field sound attenuation device, add a nearfield noise attenuation device; adjust hammer operations; adjust noise attenuation system to improve performance); provide an explanation to NMFS GARFO, BOEM, BSEE, and USACE supporting that determination and requesting concurrence to proceed; and, following NMFS GARFO's concurrence, deploy those additional measures on any subsequent piles that are installed (e.g., if threshold distances are exceeded on pile 1 then additional measures must be deployed before installing pile 2). NMFS GARFO will strive to provide concurrence as quickly as possible following review of the submission and necessary coordination with the action agencies and will ensure communication with the action agencies and BOEM no later than two business days after receiving CVOW-C's proposal and request for concurrence.
    - ii. If any of the SFV measurements indicate that the distances to level A thresholds for ESA-listed whales (peak or cumulative) or PTS peak or cumulative thresholds for sea turtles are greater than the modeled distances assuming 10 dB attenuation (see Table 34, Table 37, and Table 40), the clearance and shutdown zones (see Table 48) for subsequent piles must be increased so that they are at least the size of the distances to those thresholds as indicated by SFV (e.g., if threshold distances are exceeded on pile 1 then the clearance

and shutdown zones for pile 2 must be expanded). For every 1,500 m that a marine mammal clearance or shutdown zone is expanded, additional PSOs must be deployed from additional platforms/vessels to ensure adequate and complete monitoring of the expanded shutdown and/or clearance zone; CVOW-C must submit a proposed monitoring plan for NMFS GARFO's concurrence describing the proposed deployment of additional PSOs including the number of PSOs and location of all PSOs. In the event that the clearance or shutdown zone for sea turtles needs to be expanded, the proposed monitoring plan must also include a description of how additional PSOs will be deployed to ensure effective monitoring for sea turtles in the expanded zones.

- iii. If, after implementation of 3.a.i, any subsequent SFV measurements indicate that the distances to any identified isopleth of concern are still greater than those modeled assuming 10 dB attenuation (see Table 34, Table 37, and Table 40), CVOW-C must identify and propose for review and concurrence: additional modified, and/or alternative noise attenuation measures or operational changes that present a reasonable likelihood of reducing sound levels to the modeled distances; provide an explanation to NMFS GARFO, BOEM, BSEE, and USACE supporting that determination and requesting concurrence to proceed; and, following NMFS GARFO's concurrence, deploy those additional measures or modifications on any subsequent piles that are installed (e.g., if threshold distances are still exceeded on pile 2 the additional measures must be deployed for pile 3). NMFS GARFO will strive to provide concurrence as quickly as possible following review of the submission and necessary coordination with the action agencies and will ensure communication with the action agencies and BOEM no later than two business days after receiving CVOW-C's proposal and request for concurrence. Clearance and shutdown zones must be expanded consistent with the requirements of 3.b.ii.
- iv. Following installation of the pile with additional modified, and/or alternative noise attenuation measures or operational changes required by 3.a.iii, if SFV results indicate that any isopleths of concern are still larger than those modeled assuming 10 dB attenuation, before any additional piles can be installed, CVOW-C must and propose for review and concurrence: additional, modified, and/or alternative noise attenuation measures or operational changes that present a reasonable likelihood of reducing sound levels to the modeled distances; provide an explanation to NMFS GARFO, BOEM, BSEE, and USACE supporting that determination and requesting concurrence to proceed; and, following NMFS GARFO's concurrence, deploy those additional measures or modifications on any subsequent piles that are installed. Following concurrence from NMFS GARFO, BOEM, BSEE, and USACE must require and CVOW-C must implement those measures and any expanded clearance and shutdown zone sizes (and any required additional PSOs) consistent with the requirements of 3.b.ii. Additionally, BOEM, BSEE, and USACE must require and CVOW-C must continue SFV for two additional piles with enhanced sound attenuation measures and submit the interim reports as required above (for a total of at least three piles with consistent noise attenuation measures).
  1. If no additional measures are identified for implementation, or if the SFV required by 3.a.iv indicates that the distance to any isopleths of concerns for any ESA-listed species are still larger than those modeled assuming 10 dB attenuation, NMFS GARFO will presume that reinitiation of consultation is necessary,

- consistent with 50 CFR §402.16(a)(2) and/or (a)(3). NMFS GARFO, NMFS OPR, BOEM, BSEE, and USACE will meet within three business days to discuss: the results of SFV monitoring, the severity of exceedance of distances to identified isopleths of concern, the species affected, modeling assumptions, and whether any triggers for reinitiation of consultation are met (50 CFR 402.16), including consideration of whether the SFV results constitute new information revealing effects of the action that may affect listed species in a manner or to an extent not previously considered in the consultation.
- v. Following installation of the pile with additional alternative, or modified noise attenuation measures/operational changes required by 3.a.iii or 3.a.iv, if SFV results indicate that all isopleths of concern are within distances to isopleths of concern modeled assuming 10 dB attenuation (see Table 34, Table 37, and Table 40), SFV must be conducted on two additional piles (for a total of at least three piles with consistent noise attenuation measures). If the SFV results from all three of those piles are within the distances to isopleths of concern modeled assuming 10 dB attenuation, BOEM, BSEE, and USACE must require, and CVOW-C Wind must continue to implement the approved additional, alternative, or modified sound attenuation measures/operational changes, BOEM, BSEE, USACE and/or CVOW-C can request concurrence from NMFS GARFO to the original clearance and shutdown zones (Table 48) or CVOW-C can continue with the expanded clearance and shutdown zones with additional PSOs.
  - b. Consistent with the measures incorporated into the proposed action, BOEM, BSEE, and USACE must require, and CVOW-C must implement SFV on all piles associated with installation of all three OSS foundations with the additional requirements specified here (see also T&C 8.d. below). If any of the SFV measurements from the first OSS foundation installation indicate that the distance to any isopleth of concern is larger than those modeled assuming 10 dB attenuation (see Table 34, Table 37, and Table 40), before the second OSS foundation is installed BOEM, BSEE, and USACE must ensure that CVOW-C must:
    - i. Identify and propose for review and concurrence: additional, modified, and/or alternative noise attenuation measures or operational changes that present a reasonable likelihood of reducing sound levels to the modeled distances; provide an explanation to NMFS GARFO and NMFS OPR supporting that determination; and, following concurrence from NMFS GARFO, deploy those additional measures for the second OSS foundation. BOEM, BSEE, and USACE supporting that determination and request concurrence to proceed; and, following NMFS GARFO's concurrence, deploy those additional, modified, and/or alternative measures or modifications to operations for the second OSS foundation.
    - ii. If any of the SFV measurements indicate that the distances to level A thresholds for ESA-listed whales or PTS peak or cumulative thresholds for sea turtles are larger than the modeled distances (assuming 10 dB attenuation, see Table 34, Table 37, and Table 40), the clearance and shutdown zones (see Table 48) for the second OSS foundation must be increased to be at least the size of the distances to those thresholds as indicated by SFV. For every 1,500 m that a marine mammal clearance or shutdown zone is expanded, additional PSOs must be deployed from additional platforms or vessels to ensure adequate and complete monitoring of the expanded shutdown and/or clearance zone; CVOW must submit a proposed monitoring plan for NMFS GARFO's concurrence describing the proposed deployment of additional PSOs including the number and

location of all PSOs. In the event that the clearance or shutdown zone for sea turtles needs to be expanded, the proposed monitoring plan must also include a description of how additional PSOs will be deployed to ensure effective monitoring for sea turtles in the expanded zones.

- iii. If, after implementation of 3.b.i, any subsequent SFV measurements indicate that the distances to any identified isopleth of concern are still greater than those modeled assuming 10 dB attenuation (see Table 34, Table 37, and Table 40), CVOW-C must identify and propose for review and concurrence: additional modified, and/or alternative noise attenuation measures or operational changes that present a reasonable likelihood of reducing sound levels to the modeled distances; provide an explanation to NMFS GARFO, BOEM, BSEE, and USACE supporting that determination and requesting concurrence to proceed; and, following NMFS GARFO's concurrence, deploy those additional measures or modifications on any subsequent piles that are installed (e.g., if threshold distances are still exceeded on OSS, 2 the additional measures must be deployed for OSS 3). NMFS GARFO will strive to provide concurrence as quickly as possible following review of the submission and necessary coordination with the action agencies and will ensure communication with the action agencies and BOEM no later than two business days after receiving CVOW-C's proposal and request for concurrence. Clearance and shutdown zones must be expanded consistent with the requirements of 3.b.ii.
- iv. Following installation of the OSS with additional modified, and/or alternative noise attenuation measures or operational changes required by 3.b.iii, if SFV results indicate that any isopleths of concern are still greater than those modeled assuming 10 dB attenuation, before the third OSS can be installed, CVOW-C must and propose for review and concurrence: additional, modified, and/or alternative noise attenuation measures or operational changes that present a reasonable likelihood of reducing sound levels to the modeled distances; provide an explanation to NMFS GARFO, BOEM, BSEE, and USACE supporting that determination and requesting concurrence to proceed; and, following NMFS GARFO's, BOEM, BSEE, and USACE must require and CVOW-C must implement those measures and any expanded clearance and shutdown zone sizes (and any required additional PSOs) consistent with the requirements of 3.b.ii.
  1. If no additional measures are identified for implementation and NMFS concurs with that determination, NMFS GARFO will presume that reinitiation of consultation is necessary, consistent with 50 CFR §402.16(a)(2) and/or (a)(3). NMFS GARFO, NMFS OPR, BOEM, BSEE, and USACE will meet within three business days to discuss: the results of SFV monitoring, the severity of exceedance of distances to identified isopleths of concern, the species affected, modeling assumptions, and whether any triggers for reinitiation of consultation are met (50 CFR §402.16), including consideration of whether the SFV results constitute new information revealing effects of the action that may affect listed species in a manner or to an extent not previously considered in the consultation.
- v. Following installation of the second OSS with additional noise attenuation measures required by 3.b.iii, if SFV results indicate that all isopleths of concern are within distances those modeled assuming 10 dB attenuation (see Table 34, Table 37, and Table 40) , BOEM, BSEE, and USACE must require, and CVOW-C must continue to implement the approved additional, alternative, or modified sound attenuation

measures/operational changes, BOEM, BSEE, USACE and/or CVOW-C can request concurrence from NMFS GARFO to the original clearance and shutdown zones (Table 48) or CVOW-C can continue with the expanded clearance and shutdown zones with additional PSOs.

- c. Abbreviated SFV Monitoring (consisting of a single acoustic recorder placed at an appropriate distance from the pile) must be performed on all foundation installations for which the complete SFV monitoring outlined in 3a and 3b is not carried out. Results must be included in the weekly reports. Any indications that distances to the identified Level A and Level B harassment thresholds for whales or distances to injury or behavioral disturbance distances for sea turtles or Atlantic sturgeon must be addressed by CVOW-C, including an explanation of factors that contributed to the exceedance and corrective actions that were taken to avoid exceedance on subsequent piles. BOEM, BSEE, USACE, and CVOW-C must meet with NMFS GARFO within two business days of CVOW-C's submission of a report that includes an exceedance to discuss if any additional action is necessary.
  - d. CVOW-C must inspect and carry out appropriate maintenance on the noise attenuation system prior to every pile driving event and prepare and submit a Noise Attenuation System (NAS) inspection/performance report. For piles for which full SFV is carried out, this report must be submitted as soon as it is available, but no later than when the interim SFV report is submitted for the respective pile. Performance reports for all subsequent piles must be submitted with the weekly pile driving reports. All reports must be submitted by email to [nmfs.gar.incidental-take@noaa.gov](mailto:nmfs.gar.incidental-take@noaa.gov).
    - i. Performance reports for each bubble curtain deployed must include water depth, current speed and direction, wind speed and direction, bubble curtain deployment/retrieval date and time, bubble curtain hose length, bubble curtain radius (distance from pile), diameter of holes and hole spacing, air supply hose length, compressor type (including rated Cubic Feet per Minute (CFM) and model number), number of operational compressors, performance data from each compressor (including Revolutions Per Minute (RPM), pressure, start times, and stop times), free air delivery (m<sup>3</sup>/min), total hose air volume (m<sup>3</sup>/(min m)), schematic of GPS waypoints during hose laying, maintenance procedures performed (pressure tests, inspections, flushing, re-drilling, and any other hose or system maintenance) before and after installation and timing of those tests, and the length of time the bubble curtain was on the seafloor prior to foundation installation. Additionally, the report must include any important observations regarding performance (before, during, and after pile installation), such as any observed weak areas of low pressure. The report may also include any relevant video and/or photographs of the bubble curtain(s) operating during all pile driving.
4. To implement the requirements of RPM 2, CVOW-C must file a report with NMFS GARFO ([nmfs.gar.incidental-take@noaa.gov](mailto:nmfs.gar.incidental-take@noaa.gov)) and BSEE (via TIMSWeb and notification email to [protectedspecies@bsee.gov](mailto:protectedspecies@bsee.gov)) in the event that any ESA-listed species is observed within the identified shutdown zone during active pile driving. This report must be filed within 48 hours of the incident and include the following: duration of pile driving prior to the detection of the animal(s), location of PSOs and any factors that impaired visibility or detection ability, time of first and last detection of the animal(s), distance of animal(s) at first detection, closest point of approach of animal(s) to pile, behavioral observations of the animal(s), time the PSO called for shutdown, hammer log (number of strikes, hammer energy), time the pile driving began and stopped, and any measures implemented (e.g.,

reduced hammer energy) prior to shutdown. If shutdown was determined not to be feasible, the report must include an explanation for that determination and the measures that were implemented (e.g., reduced hammer energy).

5. To implement the requirements of RPM 2, BOEM, BSEE, USACE, and CVOW-C must implement the following reporting requirements necessary to document the amount or extent of incidental take that occurs during all phases of the proposed action:
  - a. If a North Atlantic right whale is observed at any time by PSOs or project personnel, CVOW-C must ensure the sighting is immediately reported to NMFS. If immediate reporting is not possible, the report must be made within 24 hours of the sighting.
    - i. The report must be made to the appropriate geographic reporting line:
      - If in the Northeast Region (ME to VA/NC border) call (866-755-6622).
      - If in the Southeast Region (NC to FL) call (877-WHALE-HELP or 877-942-5343).
      - If calling the hotline is not possible, reports can also be made to the U.S. Coast Guard via channel 16 or through the WhaleAlert app (<http://www.whalealert.org/>).

The sighting report must include the time (note time format, e.g., UTC, EST), date, and location (latitude/longitude in decimal degrees) of the sighting, number of whales, animal description/certainty of sighting (provide photos/video if taken), lease area/project name, PSO/personnel name, PSO provider company (if applicable), and reporter's contact information.
    - ii. If a North Atlantic right whale is detected at any time by PSOs/PAM Operators via PAM, CVOW-C must ensure the detection is reported as soon as possible and no longer than 24 hours after the detection to NMFS via the 24-hour North Atlantic right whale Detection Template (<https://www.fisheries.noaa.gov/resource/document/passive-acoustic-reporting-system-templates>). Calling the hotline is not necessary when reporting PAM detections via the template.
    - iii. A summary report must be sent within 24 hours to NMFS GARFO ([nmfs.gar.incidental-take@noaa.gov](mailto:nmfs.gar.incidental-take@noaa.gov)) and NMFS OPR ([PR.ITP.MonitoringReports@noaa.gov](mailto:PR.ITP.MonitoringReports@noaa.gov)) with the above information and confirmation the sighting/detection was reported to the respective hotline, the vessel/platform from which the sighting/detection was made, activity the vessel/platform was engaged in at time of sighting/detection, project construction and/or survey activity ongoing at time of sighting/detection (e.g., pile driving, cable installation, HRG survey), distance from vessel/platform to animal at time of initial sighting/detection, closest point of approach of whale to vessel/platform, vessel speed, and any mitigation actions taken in response to the sighting.
  - b. In the event of a suspected or confirmed vessel strike of any ESA-listed species (e.g. marine mammal, sea turtle, listed fish) by any vessel associated with the Project or other means by which project activities caused a non-auditory injury or death of a ESA-listed species, CVOW-C must immediately report the incident to NMFS. If in the Greater Atlantic Region (ME-VA), call the NMFS Greater Atlantic Stranding Hotline (866-755-6622) and if in the Southeast Region (NC-FL), call the NMFS Southeast Stranding Hotline (877-942-5343). As well as notify BSEE (via TIMSWeb and notification email to ([protectedspecies@bsee.gov](mailto:protectedspecies@bsee.gov))). Separately, CVOW-C must immediately report the incident to NMFS GARFO ([nmfs.gar.incidental-take@noaa.gov](mailto:nmfs.gar.incidental-take@noaa.gov)), and if in the Southeast region (NC-FL), also to NMFS SERO ([secmammalreports@noaa.gov](mailto:secmammalreports@noaa.gov)).



The report must include: (A) Time, date, and location (coordinates) of the incident; (B) Species identification (if known) or description of the animal(s) involved (i.e., identifiable features including animal color, presence of dorsal fin, body shape and size); (C) Vessel strike reporter information (name, affiliation, email for person completing the report); (D) Vessel strike witness (if different than reporter) information (name, affiliation, phone number, platform for person witnessing the event); (E) Vessel name and/or MMSI number; (F) Vessel size and motor configuration (inboard, outboard, jet propulsion); (G) Vessel's speed leading up to and during the incident; (H) Vessel's course/heading and what operations were being conducted (if applicable); (I) Part of vessel that struck whale (if known); (J) Vessel damage notes; (K) Status of all sound sources in use; (L) If animal was seen before strike event; (M) behavior of animal before strike event; (N) Description of avoidance measures/requirements that were in place at the time of the strike and what additional measures were taken, if any, to avoid strike; (O) Environmental conditions (e.g., wind speed and direction, Beaufort sea state, cloud cover, visibility) immediately preceding the strike; (P) Estimated (or actual, if known) size and length of animal that was struck; (Q) Description of the behavior of the marine mammal immediately preceding and following the strike; (R) If available, description of the presence and behavior of any other marine mammals immediately preceding the strike; (S) Other animal details if known (e.g., length, sex, age class); (T) Behavior or estimated fate of the animal post-strike (e.g., dead, injured but alive, injured and moving, external visible wounds (linear wounds, propeller wounds, non-cutting blunt-force trauma wounds), blood or tissue observed in the water, status unknown, disappeared); (U) To the extent practicable, photographs or video footage of the animal(s); and (V) Any additional notes the witness may have from the interaction. For any numerical values provided (i.e., location, animal length, vessel length etc.), please provide if values are actual or estimated. Reports of Atlantic sturgeon take must include a statement as to whether a fin clip sample for genetic sampling was taken. Fin clip samples are required in all cases to document the DPS of origin; the only exception to this requirement is when additional handling of the sturgeon would result in an imminent risk of injury to the fish or the survey personnel handling the fish, we expect such incidents to be limited to capture and handling of sturgeon in extreme weather. Instructions for fin clips and associated metadata are available at: <https://www.fisheries.noaa.gov/new-england-mid-atlantic/consultations/section-7-take-reporting-programmatics-greater-atlantic>, under the "Sturgeon Genetics Sampling" heading.

- c. In the event that personnel involved in the Project discover a stranded, entangled, injured, or dead ESA-listed species (e.g. marine mammal, sea turtle, listed fish), CVOW-C must immediately report the observation to NMFS. If in the Greater Atlantic Region (ME-VA) call the NMFS Greater Atlantic Stranding Hotline (866-755-6622) and if in the Southeast Region (NC-FL) call the NMFS Southeast Stranding Hotline (877-942-5343). Separately, CVOW-C must report the incident, if in the Greater Atlantic region (ME to VA) to GARFO ([nmfs.gar.incidental-take@noaa.gov](mailto:nmfs.gar.incidental-take@noaa.gov)) or if in the Southeast region (NC-FL) to NMFS SERO ([secmammalreports@noaa.gov](mailto:secmammalreports@noaa.gov)) as soon as feasible. As well as notify BSEE (via TIMSWeb and notification email to [protectedspecies@bsee.gov](mailto:protectedspecies@bsee.gov)). Note, the stranding hotline may request the report be sent to the local stranding network response team. Reports of listed fish should only be sent to [nmfs.gar.incidental-take@noaa.gov](mailto:nmfs.gar.incidental-take@noaa.gov). The report must include: (A) Contact information (name, phone number, etc.), time, date, and location (coordinates) of the first discovery (and updated location information if known and applicable); (B) Species identification (if known) or description of the animal(s) involved; (C) Condition of the animal(s) (including carcass condition



if the animal is dead); (D) Observed behaviors of the animal(s), if alive; (E) If available, photographs or video footage of the animal(s); and (F) General circumstances under which the animal was discovered. Staff responding to the hotline call will provide any instructions for handling or disposing of any injured or dead animals, which may include coordination of transport to shore, particularly for injured sea turtles.

- d. CVOW-C must compile and submit weekly reports during pile driving that document the pile ID, type of pile, pile diameter, start and finish time of each pile driving event, hammer log (number of strikes, max hammer energy, duration of piling) per pile, any changes to noise attenuation systems and/or hammer schedule, details on the deployment of PSOs and PAM operators, including the start and stop time of associated observation periods by the PSOs and PAM Operators, and a record of all observations/detections of marine mammals and sea turtles, including time (UTC) of sighting/detection, species ID, behavior, distance (meters) from vessel to animal at time of sighting/detection (meters), animal distance (meters) from pile installation vessel, vessel/project activity at time of sighting/detection, platform/vessel name, and mitigation measures taken (if any) and reason. Sightings/detections during pile driving activities (clearance, active pile driving, post-pile driving) and all other (transit, opportunistic, etc.) sightings/detection must be reported and identified as such. These weekly reports must be submitted to NMFS GARFO ([nmfs.gar.incidental-take@noaa.gov](mailto:nmfs.gar.incidental-take@noaa.gov)), BOEM, and BSEE by CVOW-C or the PSO providers and can consist of QA/QC'd raw data. Weekly reports are due on Wednesday for the activities occurring the previous week (Sunday – Saturday, local time).
- e. Starting in the first month that in-water activities occur (e.g., cofferdam installation, fisheries surveys, and HRG activities), CVOW-C must compile and submit monthly reports that include a summary of all project activities carried out in the previous month, including dates and location of any fisheries surveys carried out, vessel transits (name, type of vessel, number of transits, vessel activity, and route (this includes transits from all ports, foreign and domestic), cable installation activities (including sea to shore transition), number of piles installed and pile IDs, and all sightings/detections of ESA-listed whales, sea turtles, and sturgeon, inclusive of any mitigation measures taken as a result of those observations. Sightings/detections must include species ID, time, date, initial detection distance, vessel/platform name, vessel activity, vessel speed, bearing to animal, project activity, and if any mitigation measures taken. These reports must be submitted to NMFS GARFO ([nmfs.gar.incidental-take@noaa.gov](mailto:nmfs.gar.incidental-take@noaa.gov)) and are due on the 15<sup>th</sup> of the month for the previous month.
- f. CVOW-C must submit to NMFS GARFO ([nmfs.gar.incidental-take@noaa.gov](mailto:nmfs.gar.incidental-take@noaa.gov)) an annual report describing all activities carried out to implement their Fisheries Research and Monitoring Plan. This report must include a summary of all activities conducted, the dates and locations of all fisheries surveys, summarized by month, number of vessel transits inclusive of port of origin and destination, and a summary table of any observations of ESA-listed species during these surveys. Each annual report is due by February 15 (i.e., the report for 2024 activities is due by February 15, 2025).
- g. BOEM, BSEE, and/or CVOW-C must submit full detection data, metadata, and location of recorders (or GPS tracks, if applicable) from all real-time hydrophones used for monitoring during construction within 90 calendar days after pile-driving has ended. Reporting must use the

webform templates on the NMFS Passive Acoustic Reporting System website at <https://www.fisheries.noaa.gov/resource/document/passive-acoustic-reporting-system-templates>. BOEM, BSEE, and/or CVOW-C must submit the full acoustic recordings from all the real-time hydrophones to the National Centers for Environmental Information (NCEI) for archiving within 90 calendar days after pile-driving has ended and instruments have been pulled from the water. Archiving guidelines outlined here (<https://www.ncei.noaa.gov/products/passive-acoustic-data#tab-3561>) must be followed. Confirmation of both submittals must be sent to NMFS GARFO.

6. To implement the requirements of RPM 2 and to facilitate monitoring of the incidental take exemption for sea turtles, BOEM, BSEE, USACE, and NMFS must meet twice annually to review sea turtle observation records. These meetings/conference calls will be held in September (to review observations through August of that year) and December (to review observations from September to November) and will use the best available information on sea turtle presence, distribution, and abundance, project vessel activity, and observations to estimate the total number of sea turtle vessel strikes in the action area that are attributable to project operations.
7. To implement RPM 2, within 10 business days of BOEM, BSEE, and/or USACE obtaining updated information on project plans (i.e., as obtained through a relevant Facility Design Report (FDR)/Fabrication and Installation Report (FIR) or other submission), BOEM, BSEE, and/or USACE must provide NMFS GARFO ([nmfs.gar.incidental-take@noaa.gov](mailto:nmfs.gar.incidental-take@noaa.gov)) with the following information: number and size of foundations to be installed to support wind turbine generators and offshore substations, installation method for the sea to shore transition (e.g., casing pipe, cofferdam, no containment), the proposed construction schedule (i.e., months when pile driving is planned), and any available updates on anticipated vessel transit routes (e.g., any changes to the ports identified for use by project vessels) that will be used by project vessels. NMFS GARFO will review this information and request a meeting with BOEM, BSEE, and USACE if there is any indication that there are changes to the proposed action that would cause an effect to listed species or critical habitat that was not considered in this Opinion, including the amount or extent of predicted take, such that any potential trigger for reinitiation of consultation can be discussed with the relevant action agencies.
8. To implement RPM 3, the plans identified below must be submitted to NMFS GARFO at [nmfs.gar.incidental-take@noaa.gov](mailto:nmfs.gar.incidental-take@noaa.gov) by BOEM, BSEE, and/or CVOW-C. Any of the identified plans can be combined such that a single submitted plan addresses multiple requirements provided that the plan clearly identifies which requirements it is addressing. For each plan, within 45 calendar days of receipt of the plan, NMFS GARFO will provide comments to BOEM, BSEE, and CVOW-C, including a determination as to whether the plan is consistent with the requirements outlined in this ITS and/or in Section 3 (Description of the Proposed Actions) of this Opinion. If the plan is determined to be inconsistent with these requirements, BOEM, BSEE and/or CVOW-C must resubmit a modified plan that addresses the identified issues within 30 days of the receipt of the comments, but at least 15 calendar days before the start of the associated activity. At that time, BOEM, BSEE and NMFS GARFO and OPR will discuss a timeline for review and approval of the modified plan. If further revisions are necessary, at all times, NMFS GARFO, BOEM, and BSEE will be provided at least three business days for review and, whenever possible, NMFS GARFO, BOEM, and BSEE will aim to provide responses within four business days. BOEM, BSEE and CVOW-C must receive NMFS GARFO's concurrence with these plans before the identified activity is carried out:

- a. **Passive Acoustic Monitoring Plan for Pile Driving.** BOEM, BSEE, and/or CVOW-C must submit this Plan to NMFS GARFO at least 180 calendar days before impact pile driving is planned. BOEM, BSEE, and CVOW-C must obtain NMFS GARFO's concurrence with this Plan prior to the start of any pile driving. The Plan must include a description of all proposed PAM equipment and hardware, the calibration data, bandwidth capability and sensitivity of hydrophones, and information addressing how the proposed passive acoustic monitoring will follow standardized measurement, processing methods, reporting metrics, and metadata standards for offshore wind (Van Parijs *et al.*, 2021). The Plan must describe and include all procedures, documentation, and protocols, including information (i.e., testing, reports, equipment specifications) to support that it will be able to detect vocalizing whales within the clearance and shutdown zones, including deployment locations, procedures, detection review methodology, and protocols; hydrophone detection ranges with and without foundation installation activities and data supporting those ranges; communication time between call and detection, and data transmission rates between PAM Operator and PSOs on the pile driving vessel; where PAM Operators will be stationed relative to hydrophones and PSOs on pile driving vessel calling for delay/shutdowns; and a full description of all proposed software, call detectors, and filters. The Plan must also incorporate the requirements relative to North Atlantic right whale reporting in 5.a.
  
- b. **Marine Mammal and Sea Turtle Monitoring Plan – Pile Driving.** BOEM, BSEE, and/or CVOW-C must submit this Plan to NMFS GARFO at least 180 calendar days before any pile driving for foundation installation is planned. BOEM, BSEE, and/or CVOW-C must obtain NMFS GARFO's concurrence with this Plan(s) prior to the start of any pile driving for foundation installation. The Plan(s) must include: a description of how all relevant mitigation and monitoring requirements contained in the incidental take statement will be implemented, a pile driving installation summary and sequence of events, a description of all training protocols for all project personnel (PSOs, PAM Operators, trained crew lookouts, etc.), a description of all monitoring equipment and evidence (i.e., manufacturer's specifications, reports, testing) that it can be used to effectively monitor and detect ESA-listed marine mammals and sea turtles in the identified clearance and shutdown zones (i.e., field data demonstrating reliable and consistent ability to detect ESA-listed large whales and sea turtles at the relevant distances in the conditions planned for use), communications and reporting details, and PSO monitoring and mitigation protocols (including number and location of PSOs) for effective observation and documentation of sea turtles and ESA-listed marine mammals during all pile driving events. The Plan(s) must demonstrate sufficient PSO and PAM Operator staffing (in accordance with watch shifts), PSO and PAM Operator schedules, and contingency plans for instances if additional PSOs and PAM Operators are required. The Plan must detail all plans and procedures for sound attenuation, including procedures for adjusting the noise attenuation system(s) and available contingency noise attenuation measures/systems if distances to modeled isopleths of concern are exceeded during SFV. The plan must also describe how CVOW-C would determine the number of sea turtles exposed to noise above the 175 dB harassment threshold during impact pile driving of WTG and OSS foundations and how CVOW-C would determine the number of ESA-listed whales exposed to noise above the Level B harassment (behavioral disturbance) threshold during impact pile driving of WTG and OSS foundations.

- c. **Reduced Visibility Monitoring Plan.** BOEM, BSEE, and/or CVOW-C must submit this Plan to NMFS GARFO at least 180 calendar days before impact pile driving is planned to begin. BOEM, BSEE, and CVOW-C must obtain NMFS GARFO's concurrence with this Plan prior to the start of pile driving. This Plan must contain a thorough description of how CVOW-C will monitor pile driving activities during reduced visibility conditions (e.g. rain, fog) and at night (i.e., between 1.5 hours prior to civil sunset and 1 hour after civil sunrise), including proof of the efficacy of monitoring devices (e.g., mounted thermal/infrared camera systems, hand-held or wearable night vision devices NVDs, spotlights) in detecting ESA-listed marine mammals and sea turtles over the full extent of the required clearance and shutdown zones, including demonstration that the full extent of the minimum visibility zones (2,000 m for WTG and OSS foundations, 1,000 m for goal posts) can be effectively and reliably monitored. The Plan must identify the efficacy of the technology at detecting marine mammals and sea turtles in the clearance and shutdown zones under all the various conditions anticipated during construction, including varying weather conditions, sea states, and in consideration of the use of artificial lighting. The Plan must include a full description of the proposed technology, monitoring methodology, and data demonstrating to NMFS GARFO's satisfaction that marine mammals and sea turtles can reliably and effectively be detected within the clearance and shutdown zones for foundation piles before and during impact pile driving. Additionally, this Plan must contain a thorough description of how CVOW-C will monitor pile driving activities during daytime when unexpected changes to lighting or weather occur during pile driving that prevent visual monitoring of the full extent of the clearance and shutdown zones.
- d. **Sound Field Verification Plan - WTG and OSS Installation.** BOEM, BSEE, and/or CVOW-C must submit this Plan to NMFS GARFO at least 180 calendar days before pile driving for WTG and/or OSS foundations is planned to begin. BOEM, BSEE, and CVOW-C must obtain NMFS GARFO's concurrence with this Plan(s) prior to the start of these pile driving activities. To validate the estimated sound fields, SFV measurements will be conducted during pile driving of the first three monopiles and the three OSS foundations (inclusive of all four pin piles) installed over the course of the Project, with noise attenuation activated (inclusive of vibratory and impact driving). The Plan(s) must describe how the first three monopile installation sites and installation scenarios (i.e., hammer energy, number of strikes) are representative of the rest of the monopile installations and, therefore, why these monopile installations would be representative of the remaining monopile installations. If the monitored pile locations are different from the ones used for exposure modeling, justification must be provided for why these locations are representative of the modeling. In the case that these sites are not determined to be representative of all other monopile installation sites, CVOW-C must include information on how additional monopiles/sites would be selected for SFV. The Plan(s) must also include the piling schedule and sequence of events, communication and reporting protocols, methodology for collecting, analyzing, and preparing SFV data for submission to NMFS GARFO, including instrument deployment, locations of all hydrophones, including direction and distance from the pile, hydrophone sensitivity, recorder/measurement layout, and analysis methods, and a template of the interim report to be submitted. The Plan must also identify the number and location of hydrophones that will be reported in the SFV Interim Reports and any additional hydrophone locations that will be included in the final report(s). The Plan must describe how the effectiveness of the sound attenuation methodology will be evaluated based on the results. The Plan must address how CVOW-C will implement Terms and Conditions 3a and 3b (see above)

which includes, but is not limited to identifying additional noise attenuation measures (e.g., add noise attenuation device, adjust hammer operations, adjust NMS) that will be applied to reduce sound levels if measured distances are greater than those modeled. The plan must describe how Abbreviated SFV Monitoring (consisting of a single acoustic recorder placed at an appropriate distance from the pile) required by Term and Condition 3.c. will be performed on all foundation installations for which the complete SFV monitoring outlined in 3a and 3b is not carried out. The plan must also outline the anticipated results that will be included in the weekly reports. The plan must also specify steps that will be taken should any exceedances occur.

- i. SFV Interim Reports - Pile Driving. BOEM, BSEE, and USACE must require and CVOW-C must provide, as soon as they are available but no later than 48 hours after the installation of each of the first three monopiles and after each of the three OSS foundations (inclusive of all four pin piles), the initial results of the SFV measurements to NMFS GARFO in an interim report. If technical or other issues prevent submission within 48 hours, CVOW-C must notify BOEM, BSEE, and NMFS GARFO within that 48-hour period with the reasons for delay and provide an anticipated schedule for submission of the report. These reports are required for each of the first three monopiles and each of the three OSS foundations installed, and any additional piles for which SFV is required. The interim report must include data from hydrophones identified for interim reporting in the SFV Plan and include a summary of pile installation activities (pile diameter, pile weight, pile length, water depth, sediment type, hammer type, total strikes, total installation time [start time, end time], duration of pile driving, max single strike energy, NAS deployments), pile location, recorder locations, modeled and measured distances to thresholds, received levels (rms, peak, and SEL) results from Conductivity, Temperature, and Depth (CTD) casts/sound velocity profiles, signal and kurtosis rise times, pile driving plots, activity logs, and weather conditions. Additionally, any important sound attenuation device malfunctions (suspected or definite), must be summarized and substantiated with data (e.g. photos, positions, environmental data, directions, etc.) and observations. Such malfunctions include gaps in the bubble curtain, significant drifting of the bubble curtain, and any other issues which may indicate sub-optimal mitigation performance or are used by CVOW-C to explain performance issues. Requirements for actions to be taken based on the results of the SFV are identified in 3.a. above.
  - ii. The final results of SFV for monopile and pin pile installations must be submitted as soon as possible, but no later than within 90 days following completion of pile driving for which SFV was carried out.
- e. Vessel Strike Avoidance Plan. BOEM, BSEE, and/or CVOW-C must submit this plan to NMFS GARFO as soon as possible after issuance of this Opinion but no later than 180 days prior to the planned start of in-water construction activities (including cable installation). The Plan must provide details on all relevant mitigation and monitoring measures for listed species, vessel speeds and transit protocols from all planned ports, vessel-based observer protocols for transiting vessels, communication and reporting plans, proposed alternative monitoring equipment to maintain vessel strike avoidance zones in varying weather conditions, darkness, sea states, and in consideration of the use of artificial lighting. If CVOW-C plans to implement PAM in any transit

corridor to allow vessel transit above 10 knots, the plan must describe how PAM, in combination with visual observations, will be conducted to ensure the transit corridor is clear of North Atlantic right whales. PAM information should follow what is required to be submitted for the PAM Plan in 8.a.

9. To implement the requirements of RPM 4, BOEM and BSEE must exercise their authorities to assess the implementation of measures to avoid, minimize, monitor, and report incidental take of ESA-listed species during activities described in this Opinion. BOEM and/or BSEE shall immediately exercise their respective authorities to take effective action to ensure prompt implementation and compliance if CVOW-C is not complying with: any avoidance, minimization, and monitoring measures incorporated into the proposed action or any term and condition(s) specified in this statement, as currently drafted or otherwise amended in agreement between the BOEM, BSEE, and NMFS; if BOEM and/or BSEE fail to do so, the protective coverage of section 7(o)(2) may lapse.
10. To implement the requirements of RPM 4, CVOW-C must consent to on-site observation and inspections by Federal agency personnel (including NOAA personnel) during activities described in this Opinion, for the purposes of evaluating the effectiveness and implementation of measures designed to minimize or monitor incidental take.

**Table 48. Clearance and Shutdown Zones for ESA-listed Species.**

Species	Clearance Zone (m)	Shutdown Zone (m)
<b>Impact Pile Driving of Foundations</b>		
North Atlantic right whale (NARW) – visual detection	Minimum visibility zone plus any additional distance observable by the visual PSOs	Minimum visibility zone plus any additional distance observable by the visual PSOs
NARW – Passive Acoustic Monitoring (PAM)	any distance	any distance
Fin, Sei, and Sperm Whale – WTG	5,100 <sup>a</sup>	1,750
Sea Turtles	1,000	500
<b>Vibratory Pile Driving of Foundations or Cofferdams</b>		
NARW- visual detection	any distance	any distance
Fin, Sei, and Sperm Whale	1,000	1,000
Sea Turtles	1,000	100
<b>Impact Pile Driving of Goal Post Piles</b>		

NARW - visual detection	any distance	any distance
Fin, Sei, and Sperm Whale	1,000	1,000
Sea Turtles	1,000	100
<b>HRG Surveys</b>		
NARW - visual detection	500	500
Fin, Sei, and Sperm Whale	500	500
Sea Turtles	500	100

<sup>a</sup> Distance for a one pile per day scenario. The two pile per day scenario is 6,500 m. All other categories have the same values for either one or two piles per day.

Note: The zones for marine mammals reflect the proposed conditions of the MMPA ITA and the zones for sea turtles reflect the zone sizes identified in BOEM's BA, except the sea turtle shut down distance for Impact Pile Driving of Foundations, which was increased under Term and Condition #1.

## 12 CONSERVATION RECOMMENDATIONS

In addition to section 7(a)(2), which requires agencies to ensure that all projects will not jeopardize the continued existence of listed species, section 7(a)(1) of the ESA places a responsibility on all Federal agencies to "utilize their authorities in furtherance of the purposes of this Act by carrying out programs for the conservation of endangered species." Conservation recommendations are discretionary agency activities to minimize or avoid adverse effects of a proposed action on listed species or critical habitat, to help implement recovery plans, or to develop information in furtherance of these identified purposes. As such, NMFS recommends that the BOEM, BSEE, USACE, and the other action agencies consider implementing the following Conservation Recommendations consistent with their authorities:

1. Information on underwater noise generated during vibratory pile driving for installation and removal of sheet piles in the action area is limited. Information on operational noise of direct drive wind turbine generators is also limited.
  - a. Sound field verification should be carried out during installation and removal of at least one cofferdam.
  - b. A study to document operational noise during a variety of wind and weather conditions should be carried out.
2. Research and development should be supported to aid in minimization of risk of vessel strikes on marine mammals, sea turtles, and Atlantic sturgeon.
3. Development of regional monitoring of cumulative impacts of this and future projects through the Regional Wildlife Science Collaborative (RWSC) should be supported.
4. Work should be done with the NEFSC to support robust monitoring and study design with adequate sample sizes, appropriate spatial and temporal coverage, and proper design allowing the detection of potential impacts of offshore wind projects on a wide range of environmental conditions including protected species distribution, prey distribution, and habitat usage.
5. Research into understanding and modeling effects of offshore wind on regional oceanic and atmospheric conditions and potential impacts on protected species, their habitats, and distribution of zooplankton and other prey should be supported.

6. Continuation of aerial surveys for post-construction monitoring of listed species in the lease area and surrounding waters should be supported and all sightings of NARWs should be contributed to the NMFS Sighting Advisory System.
7. Research on construction and operational impacts to protected species distribution, particularly the NARW and other listed whales should be supported. Monitoring pre/during/post construction should be conducted, including long-term monitoring during the operational phase, including sound sources associated with turbine maintenance (e.g., service vessels), to understand any changes in protected species distribution and habitat use in the Virginia Wind Energy Area and Mid-Atlantic region.
8. An acoustic telemetry array should be developed in the WDA, and research should be supported for the tracking of sturgeon and deployment of acoustic tags on sea turtles, as well as other acoustically-tagged species.
9. Research should be conducted regarding the abundance and distribution of Atlantic sturgeon in the wind lease area and surrounding region in order to understand the distribution and habitat use and aid in density modeling efforts, including the use of acoustic telemetry networks to monitor for tagged fish.
10. All acoustic telemetry data should be submitted to the Mid-Atlantic Acoustic Telemetry Observation System (MATOS) database for coordinated tracking of marine species over broader spatial scales in US Animal Tracking Network and Ocean Tracking Network.
11. Long-term ecological monitoring should be conducted to document the changes to the ecological communities on, around, and between wind turbine generator foundations and other benthic areas disturbed by the proposed project.
12. A PAM array should be developed in the WDA to monitor use of the area by baleen whales during the life of the project, including construction, and to detect small-scale changes at the scale of the WDA. Bottom-mounted recorders should be deployed at a maximum of 20 km distance from each other throughout the given study area in order to ensure near to complete coverage of the area over which NARW and other baleen whales can be heard (see NOAA/BOEM PAM Recommendations for specific details). Resulting data products should be provided according to the NOAA/BOEM PAM recommendations.
13. Development of a regional PAM network should be supported across lease areas to monitor long-term changes in baleen whale distribution and habitat use. A regional PAM network should consider adequate array/hydrophone design, equipment, and data evaluation to understand changes over the spatial scales that are relevant to these species for the duration of these projects, as well as the storage and dissemination of these data.
14. Changes in commercial fishing activity should be monitored to detect changes in bycatch or entanglement rates of protected species, particularly the NARW, and support the adaptation of ropeless fishing practices where necessary.
15. Support should be provided to groups that participate in regional stranding networks.

### **13 REINITIATION NOTICE**

This concludes formal consultation for the proposed CVOW-C offshore energy project Federal actions by BOEM, BSEE, NMFS, USACE, USCG, and EPA. As 50 C.F.R. §402.16 states, reinitiation of formal consultation is required and shall be requested by the Federal agency or by the Service, where discretionary Federal involvement or control over the action has been retained or is authorized by law and:



- (1) If the amount or extent of taking specified in the incidental take statement is exceeded;
- (2) If new information reveals effects of the action that may affect listed species or critical habitat in a manner or to an extent not previously considered;
- (3) If the identified action is subsequently modified in a manner that causes an effect to the listed species or critical habitat that was not considered in the biological opinion or written concurrence; or,
- (4) If a new species is listed or critical habitat designated that may be affected by the identified action.

## 14 LITERATURE CITED

- Ackerman, R. A. 1997. The nest environment and the embryonic development of sea turtles. Pages 83-106 in J. A. P. L. M. Lutz, editor. *The Biology of Sea Turtles*. CRC Press, Boca Raton.
- Ackleh, A. S., and coauthors. 2017. Analysis of lethal and sublethal impacts of environmental disasters on sperm whales using stochastic modeling. *Ecotoxicology*.
- Aerts, L. A. M., and W. J. Richardson. 2008. Monitoring of industrial sounds, seals, and bowhead whales near BP's Northstar Oil Development, Alaskan Beaufort Sea, 2007: Annual Summary Report. LGL Rep. P1005b. Rep. from LGL Alaska Research Associates (Anchorage, AK), Greeneridge Sciences Inc. (Santa Barbara, CA) and Applied Sociocultural Research (Anchorage, AK) for BP Exploration (Alaska) Inc, Anchorage, AK.
- Afsharian, S., and P. A. Taylor. 2019. On the potential impact of Lake Erie wind farms on water temperatures and mixed-layer depths: Some preliminary 1-D modeling using COHERENS. *Journal of Geophysical Research: Oceans* 124(3):1736-1749.
- Afsharian, S., P. A. Taylor, and L. Momayez. 2020. Investigating the potential impact of wind farms on Lake Erie. *Journal of Wind Engineering and Industrial Aerodynamics* 198:104049.
- Aguirre, A. A., and coauthors. 2006. Hazards associated with the consumption of sea turtle meat and eggs: A review for health care workers and the general public. *Ecohealth* 3(3):141-153.
- Allen, M. R., and coauthors. 2018. Technical Summary. V. Masson-Delmotte, and coeditors, editors. *Global Warming of 1.5°C. An IPCC Special Report on the impacts of global warming of 1.5°C above pre-industrial levels and related global greenhouse gas emission pathways, in the context of strengthening the global response to the threat of climate change, sustainable development, and efforts to eradicate poverty*
- Allison, C. 2017. International Whaling Commission Catch Data Base v. 6.1. As cited in Cooke, J.G. 2018. *Balaenoptera physalus*. The IUCN Red List of Threatened Species 2018:e.T2478A50349982., <http://dx.doi.org/10.2305/IUCN.UK.2018-2.RLTS.T2478A50349982.en>.
- Altenritter, M. E., G. B. Zydlewski, M. T. Kinnison, J. D. Zydlewski, and G. S. Wippelhauser. 2018. Understanding the basis of shortnose sturgeon (*Acipenser brevirostrum*) partial migration in the Gulf of Maine. *Canadian Journal of Fisheries and Aquatic Sciences* 75(3):464-473.
- Anatec Limited. 2022. Coastal Virginia Offshore Wind Commercial OCS-A 0483. Navigational Safety Risk Assessment. Document No. A4488-TT-NSRA-1, Prepared for Tetra Tech, Inc. and Dominion Energy, Inc.
- Andersson, M. H., E. Dock-Åkerman, R. Ubral-Hedenberg, M. C. Öhman, and P. Sigraý. 2007. Swimming behavior of roach (*Rutilus rutilus*) and three-spined stickleback (*Gasterosteus aculeatus*) in response to wind power noise and single-tone frequencies. *AMBIO: A journal of the Human Environment* 36(8):636-638.
- Andres, M., G. G. Gawarkiewicz, and J. M. Toole. 2013. Interannual sea level variability in the western North Atlantic: Regional forcing and remote response. *Geophysical Research Letters* 40(22):5915-5919.
- Antonelis, G. A., J. D. Baker, T. C. Johanos, R. C. Braun, and A. L. Harting. 2006. Hawaiian monk seal (*Monachus schauinslandi*): Status and conservation issues. *Atoll Research Bulletin* 543:75-101.
- Archer, F., and coauthors. 2013. Mitogenomic phylogenetics of fin whales (*Balaenoptera physalus* spp): Genetic evidence for revision of subspecies. *PLOS ONE* 8(5):e63396.
- Archer, F. I., and coauthors. 2019. Revision of fin whale *Balaenoptera physalus* (Linnaeus, 1758) subspecies using genetics. *Journal of Mammalogy*.
- ArcVera Renewables. 2022. Estimating Long-Range External Wake Losses in Energy Yield and Operational Performance Assessments Using the WRF Wind Farm Parameterization. <https://arcvera.com/wp->

[content/uploads/2022/08/ArcVera-White-Paper-Estimating-Long-Range-External-Wake-Losses-WRF-WFP-1.0.pdf](#).

- Armstrong, J. L., and J. E. Hightower. 2002. Potential for restoration of the Roanoke River population of Atlantic sturgeon. *Journal of Applied Ichthyology* 18(6-Apr):475-480.
- Aschettino, J., and coauthors. 2020. Satellite Telemetry Reveals Spatial Overlap Between Vessel High-Traffic Areas and Humpback Whales (*Megaptera novaeangliae*) Near the Mouth of the Chesapeake Bay. *Frontiers in Marine Science* 7.
- ASMFC. 1998a. Amendment 1 to the interstate fishery management plan for Atlantic sturgeon. Management Report No. 31. Atlantic States Marine Fisheries Commission.
- ASMFC. 1998b. American shad and Atlantic sturgeon stock assessment peer review: Terms of reference and advisory report. Atlantic States Marine Fisheries Commission, Washington, D. C.
- ASMFC. 1998c. Atlantic Sturgeon Stock Assessment Peer Review Report. Atlantic States Marine Fisheries Commission.
- ASMFC. 2007. Special Report to the Atlantic Sturgeon Management Board: Estimation of Atlantic sturgeon bycatch in coastal Atlantic commercial fisheries of New England and the Mid-Atlantic. Atlantic States Marine Fisheries Commission.
- ASMFC. 2010. Atlantic States Marine Fisheries Commission 2009 Annual Report. Washington, D.C.
- ASMFC. 2012. Atlantic States Marine Fisheries Commission Habitat Addendum Iv To Amendment 1 To The Interstate Fishery Management Plan For Atlantic Sturgeon.
- ASMFC. 2017. 2017 Atlantic Sturgeon Benchmark Stock Assessment and Peer Review Report. Atlantic States Marine Fisheries Commission.
- ASSRT. 2007. Status review of Atlantic sturgeon (*Acipenser oxyrinchus oxyrinchus*). National Oceanic and Atmospheric Administration, National Marine Fisheries Service, Northeast Regional Office, Atlantic Sturgeon Status Review Team.
- Avens, L., and coauthors. 2017. Variability in age and size at maturation, reproductive longevity, and long-term growth dynamics for Kemp's ridley sea turtles in the Gulf of Mexico. *PLOS ONE* 12(3):e0173999.
- Avens, L., and coauthors. 2015. Age and size at maturation- and adult-stage duration for loggerhead sea turtles in the western North Atlantic. *Marine Biology* 162(9):1749-1767.
- Avens, L., and coauthors. 2019. Regional comparison of leatherback sea turtle maturation attributes and reproductive longevity. *Marine Biology* 167(1).
- Avens, L., and K. J. Lohmann. 2003. Use of multiple orientation cues by juvenile loggerhead sea turtles. Pages 46 in J. A. Seminoff, editor *Twenty-Second Annual Symposium on Sea Turtle Biology and Conservation*.
- Avens, L., and coauthors. 2020. Regional differences in Kemp's ridley sea turtle growth trajectories and expected age at maturation. *Marine Ecology Progress Series* 654:143-161.
- Avens, L., and M. L. Snover. 2013. Age and age estimation in sea turtles. Pages 97–133 in *The Biology of Sea Turtles Volume III*. CRC Press, Boca Raton, FL.
- Avens, L., J. C. Taylor, L. R. Goshe, T. T. Jones, and M. Hastings. 2009. Use of skeletochronological analysis to estimate the age of leatherback sea turtles *Dermochelys coriacea* in the western North Atlantic. *Endangered Species Research* 8(3):165-177.
- Bailey, H., and coauthors. 2018. Determining habitat use by marine mammals and ambient noise levels using passive acoustic monitoring offshore of Maryland. OCS Study BOEM 2019-018. US Department of the Interior, Bureau of Ocean Energy Management, Sterling, VA.
- Bain, M., N. Haley, D. Peterson, J. R. Waldman, and K. Arend. 2000. Harvest and habitats of Atlantic sturgeon *Acipenser oxyrinchus Mitchill*, 1815 in the Hudson River estuary: Lessons for sturgeon conservation. *Boletín. Instituto Español de Oceanografía* 16:43-53.

- Bain, M. B. 1997. Atlantic and shortnose sturgeons of the Hudson River: Common and divergent life history attributes. *Environmental Biology of Fishes* 48(4-Jan):347-358.
- Baker, J. D., C. L. Littnan, and D. W. Johnston. 2006. Potential effects of sea level rise on the terrestrial habitats of endangered and endemic megafauna in the Northwestern Hawaiian Islands. *Endangered Species Research* 2:21-30.
- Baker, K., and U. Howsen. 2021. Data Collection and Site Survey Activities for Renewable Energy on the Atlantic Outer Continental Shelf. Biological Assessment. U.S. Department of the Interior, Bureau of Ocean Energy Management, Office of Renewable Energy Programs.
- Bakhoday-Paskyabi, M., I. Fer, and J. Reuder. 2018. Current and turbulence measurements at the FINO1 offshore wind energy site: analysis using 5-beam ADCPs. *Ocean Dynamics* 68(1):109-130.
- Balazik, M., and coauthors. 2020. Dredging activity and associated sound have negligible effects on adult Atlantic sturgeon migration to spawning habitat in a large coastal river. *PLOS ONE* 15(3):e0230029.
- Balazik, M. T., G. C. Garman, M. L. Fine, C. H. Hager, and S. P. McIninch. 2010. Changes in age composition and growth characteristics of Atlantic sturgeon (*Acipenser oxyrinchus oxyrinchus*) over 400 years. *Biol Lett* 6(5):708-10.
- Balazik, M. T., G. C. Garman, J. P. Van Eenennaam, J. Mohler, and L. C. Woods. 2012a. Empirical Evidence of Fall Spawning by Atlantic Sturgeon in the James River, Virginia. *Transactions of the American Fisheries Society* 141(6):1465-1471.
- Balazik, M. T., S. P. Mcininch, G. C. Garman, and R. J. Latour. 2012b. Age and Growth of Atlantic Sturgeon in the James River, Virginia, 1997-2011. *Transactions of the American Fisheries Society* 141(4):1074-1080.
- Balazik, M. T., and J. A. Musick. 2015. Dual annual spawning races in Atlantic sturgeon. *PLOS ONE* 10(5):e0128234.
- Barber, J. R., K. R. Crooks, and K. M. Fristrup. 2010. The costs of chronic noise exposure for terrestrial organisms. *Trends in Ecology and Evolution* 25(3):180-189.
- Barco, S. 2014. Virginia and Maryland Sea Turtle Research and Conservation Initiative Aerial Survey Sightings, May 2011 through July 2013. Data downloaded from OBIS-SEAMAP (<http://seamap.env.duke.edu/dataset/1201>) on 2023-08-16.
- Barco, S. 2015a. Virginia CZM Wind Energy Area Survey- Right side - November 2012 through April 2014. Data downloaded from OBIS-SEAMAP (<http://seamap.env.duke.edu/dataset/1194>) on 2023-08-16.
- Barco, S. 2015b. Virginia CZM Wind Energy Area Survey - Left side - May 2014 through December 2014. Data downloaded from OBIS-SEAMAP (<http://seamap.env.duke.edu/dataset/1229>) on 2023-08-16.
- Barco, S., and coauthors. 2016. Loggerhead turtles killed by vessel and fishery interaction in Virginia, USA, are healthy prior to death. *Marine Ecology Progress Series* 555:221-234.
- Barco, S. G., M. L. Burt, R. A. Digiovanni, W. M. Swingle, and A. S. Williard. 2018. Loggerhead turtle *Caretta caretta* density and abundance in Chesapeake Bay and the temperate ocean waters of the southern portion of the Mid-Atlantic Bight. *Endangered Species Research* 37:269-287.
- Barco, S. G., and coauthors. 2015. Virginia/Maryland Sea Turtle Research & Conservation Initiative. Final Report to NOAA for 739 Award #NA09NMF4720033. VAQF Scientific Report 2015-05. Virginia Aquarium Foundation, Virginia Beach, Virginia.
- Barkaszi, M. J., M. Butler, R. Compton, A. Unietis, and B. Bennet. 2012. Seismic survey mitigation measures and marine mammal observer reports. Bureau of Ocean Energy Management (BOEM), Gulf of Mexico OCS Region, New Orleans, Louisiana.
- Barkaszi, M. J., and C. J. Kelly. 2019. Seismic Survey Mitigation Measures and Protected Species Observer Reports: Synthesis Report. U.S. Dept. of the Interior, Bureau of Ocean Energy Management, Gulf of Mexico OCS Region, OCS Study BOEM 2019-012, New Orleans, LA.

- Barnette, M. 2018. Threats and Effects Analysis for Protected Resources on Vessel Traffic Associated with Dock and Marina Construction. Memorandum for David Bernhart. F/SER31: MCB.
- Baulch, S., and C. Perry. 2012. A sea of plastic: Evaluating the impacts of marine debris on cetaceans. IWC Scientific Committee, Panama City, Panama.
- Baulch, S., and C. Perry. 2014. Evaluating the impacts of marine debris on cetaceans. *Marine Pollution Bulletin* 80(2-Jan):210-221.
- Baumgartner, M. F., and D. M. Fratantoni. 2008. Diel periodicity in both sei whale vocalization rates and the vertical migration of their copepod prey observed from ocean gliders. *Limnology and Oceanography* 53(5 Part 2):2197-2209.
- Baumgartner, M. F., N. S. Lysiak, C. Schuman, J. Urban-Rich, and F. W. Wenzel. 2011. Diel vertical migration behavior of *Calanus finmarchicus* and its influence on right and sei whale occurrence. *Marine Ecology Progress Series* 423:167-184.
- Baumgartner, M. F., C. A. Mayo, and R. D. Kenney. 2007. Enormous carnivores, microscopic food, and a restaurant that's hard to find. Pages 138-171 in S. D. K. R. Rolland, editor. *The Urban Whale: North Atlantic Right Whales at the Crossroads*. Harvard University Press, Cambridge.
- Baumgartner, M. F., F. W. Wenzel, N. S. J. Lysiak, and M. R. Patrician. 2017. North Atlantic right whale foraging ecology and its role in human-caused mortality. *Marine Ecology Progress Series* 581:165-181.
- Becker, E. A., and coauthors. 2018. Predicting cetacean abundance and distribution in a changing climate. *Diversity and Distributions* 25(4):626-643.
- Bell, C. D. L., and coauthors. 2005. Some of them came home: The Cayman Turtle Farm headstarting project for the green turtle *Chelonia mydas*. *Oryx* 39(2):137-148.
- Bellmann, M. A., and coauthors. 2020. Underwater noise during percussive pile driving: Influencing factors on pile-driving noise and technical possibilities to comply with noise mitigation values. ERA Report. Supported by the Federal Ministry for the Environment, Nature Conservation and Nuclear Safety (Bundesministerium für Umwelt, Naturschutz und nukleare Sicherheit (BMU)), FKZ UM16 881500. Commissioned and managed by the Federal Maritime and Hydrographic Agency (Bundesamt für Seeschifffahrt und Hydrographie (BSH)). Order No. 10036866. Edited by the itap GmbH. .
- Bemis, W. E., and B. Canard. 1997. Sturgeon rivers: An introduction to acipenseriform biogeography and life history. *Environmental Biology of Fishes* 48:167-183.
- Benson, S. R., and coauthors. 2011. Large-scale movements and high-use areas of western Pacific leatherback turtles, *Dermochelys coriacea*. *Ecosphere* 2(7):27-Jan.
- Best, P. B., J. Bannister, R. L. Brownell, and G. Donovan. 2001. Right whales: Worldwide status.
- Betke, K., M. S.-V. Glahn, and R. Matuschek. 2004. Underwater noise emissions from offshore wind turbines. Pages 2 in CFA/DAGA '04.
- Bevelhimer, M. S., G. F. Cada, A. M. Fortner, P. E. Schweizer, and K. Riemer. 2013. Behavioral Responses of Representative Freshwater Fish Species to Electromagnetic Fields. *Transactions of the American Fisheries Society* 142(3):802-813.
- Bigelow, H. B. 1933. Studies of the waters on the continental shelf, Cape Cod to Chesapeake Bay. I. The cycle of temperature. *Papers in Physical Oceanography and Meteorology* 2(4).
- Bishop, A. L., L. M. Crowe, P. K. Hamilton, and E. L. Meyer-Gutbrod. 2022. Maternal Lineage and Habitat Use Patterns Explain Variation in the Fecundity of a Critically Endangered Baleen Whale. *Frontiers in Marine Science* 9.
- Bjorndal, K. A. 1997. Foraging ecology and nutrition of sea turtles. Pages 199–231 in *The Biology of Sea Turtles*. CRC Press, Boca Raton, Florida.
- Bjorndal, K. A., A. B. Bolten, and M. Y. Chaloupka. 2005. Evaluating trends in abundance of immature green turtles, *Chelonia mydas*, in the greater Caribbean. *Ecological Applications* 15(1):304-314.

- Bjorndal, K. A., J. Parsons, W. Mustin, and A. B. Bolten. 2014. Variation in age and size at sexual maturity in Kemp's ridley sea turtles. *Endangered Species Research* 25(1):57-67.
- Blackwell, S. B., and coauthors. 2013. Effects of airgun sounds on bowhead whale calling rates in the Alaskan Beaufort Sea. *Marine Mammal Science* 29(4):E342-E365.
- Blair, H. B., N. D. Merchant, A. S. Friedlaender, D. N. Wiley, and S. E. Parks. 2016. Evidence for ship noise impacts on humpback whale foraging behaviour. *Biol Lett* 12(8).
- Bochert, R., and M. L. Zettler. 2006a. Effect of Electromagnetic Fields on Marine Organisms. Pages 223-234 in J. Köller, J. Köppel, and W. Peters, editors. *Offshore Wind Energy: Research on Environmental Impacts*. Springer Berlin Heidelberg, Berlin, Heidelberg.
- Bochert, R., and M. L. Zettler. 2006b. Effect of electromagnetic fields on marine organisms. Pages 223-234 in Köller J., Köppel J., and P. W., editors. *Offshore Wind Energy*. Springer, Berlin, Heidelberg.
- BOEM. 2014. Atlantic OCS Proposed Geological and Geophysical Activities Mid-Atlantic and South Atlantic Planning Areas Final Programmatic Environmental Impact Statement. Bureau of Ocean Energy Management, U.S. Department of the Interior, OCS EIS/EA BOEM 2014-001, New Orleans, Louisiana.
- BOEM. 2019. Guidelines for Providing Information on Fisheries for Renewable Energy Development on the Atlantic Outer Continental Shelf Pursuant to 30 CFR Part 585. <https://www.boem.gov/sites/default/files/renewable-energy-program/Regulatory-Information/BOEM-Fishery-Guidelines.pdf>.
- BOEM. 2022. Coastal Virginia Offshore Wind Commercial Project Draft Environmental Impact Statement Volume 1. OCS EIS BOEM 2022-0021. U.S. Department of the Interior, Bureau of Ocean Energy Management, Office of Renewable Energy Programs.
- Boivin-Rioux, A., and coauthors. 2021. Predicting the Effects of Climate Change on the Occurrence of the Toxic Dinoflagellate *Alexandrium catenella* Along Canada's East Coast. *Frontiers in Marine Science* 7.
- Bolten, A., and B. Witherington. 2003. *Loggerhead Sea Turtles*. Smithsonian Books, Washington, D. C.
- Bolten, A. B., and coauthors. 1998. Transatlantic developmental migrations of loggerhead sea turtles demonstrated by mtDNA sequence analysis. *Ecological Applications* 8(1):7-Jan.
- Bolten, A. B., and coauthors. 2019. Recovery Plan for the Northwest Atlantic Population of Loggerhead Sea Turtles (*Caretta caretta*) Second Revision (2008). National Marine Fisheries Service, Silver Spring, MD.
- Bond, E. P., and M. C. James. 2017. Pre-nesting Movements of Leatherback Sea Turtles, *Dermochelys coriacea*, in the Western Atlantic. *Frontiers in Marine Science* 4.
- Bonfil, R., S. Clarke, and H. Nakano. 2008. The biology and ecology of the oceanic whitetip shark, *Carcharhinus longimanus*. Pages 128-139 in M. D. Camhi, E. K. Pikitch, and E. A. Babcock, editors. *Sharks of the open ocean: Biology, Fisheries and Conservation*. Blackwell Publishing Ltd, Oxford, United Kingdom.
- Boreman, J. 1997. Sensitivity of North American sturgeons and paddlefish to fishing mortality. *Environmental Biology of Fishes* 48(4-Jan):399-405.
- Boren, L. J., N. J. Gemmill, and K. J. Barton. 2001. Controlled approaches as an indicator of tourist disturbance on New Zealand fur seals (*Arctocephalus forsteri*). Pages 30 in Fourteenth Biennial Conference on the Biology of Marine Mammals, Vancouver, Canada.
- Bort, J., S. M. V. Parijs, P. T. Stevick, E. Summers, and S. Todd. 2015. North Atlantic right whale *Eubalaena glacialis* vocalization patterns in the central Gulf of Maine from October 2009 through October 2010. *Endangered Species Research* 26(3):271-280.
- Bowen, B. W., and J. C. Avise. 1990. Genetic structure of Atlantic and Gulf of Mexico populations of sea bass, menhaden, and sturgeon: Influence of zoogeographic factors and life-history patterns. *Marine Biology* 107(3):371-381.



- Branstetter, B. K., and coauthors. 2018. Effects of vibratory pile driver noise on echolocation and vigilance in bottlenose dolphins (*Tursiops truncatus*). *The Journal of the Acoustical Society of America* 143(1):429-439.
- Breece, M. W., and coauthors. 2016. Dynamic seascapes predict the marine occurrence of an endangered species: Atlantic Sturgeon *Acipenser oxyrinchus oxyrinchus*. *Methods in Ecology and Evolution* 7(6):725-733.
- Breece, M. W., A. L. Higgs, and D. A. Fox. 2021. Spawning Intervals, Timing, and Riverine Habitat Use of Adult Atlantic Sturgeon in the Hudson River. *Transactions of the American Fisheries Society* 150(4):528-537.
- Breece, M. W., M. J. Oliver, M. A. Cimino, and D. A. Fox. 2013. Shifting distributions of adult Atlantic sturgeon amidst post-industrialization and future impacts in the Delaware River: a maximum entropy approach. *PLOS ONE* 8(11):e81321.
- Brennan, C. E., and coauthors. 2019. A coupled dynamic model of the spatial distribution of copepod prey for the North Atlantic right whale on the Eastern Canadian Shelf. *Progress in Oceanography* (171):1-21.
- Brewer, P. G., and K. Hester. 2009. Ocean acidification and the increasing transparency of the ocean to low-frequency sound. *Oceanography* 22(4):86-93.
- Brosse, L., P. Dumont, M. Lepage, and E. Rochard. 2002. Evaluation of a gastric lavage method for sturgeons. *North American Journal of Fisheries Management* 22(3):955 - 960.
- Broström, G. 2008. On the influence of large wind farms on the upper ocean circulation. *Journal of Marine Systems* 74(1):585-591.
- Brown, J. J., and G. W. Murphy. 2010. Atlantic sturgeon vessel-strike mortalities in the Delaware Estuary. *Fisheries* 35(2):72-83.
- Brundage III, H. M., and I. J. C. O'Herron. 2009. Investigations of juvenile shortnose and Atlantic sturgeons in the lower tidal Delaware River. *Bulletin of the New Jersey Academy of Science* 54(2):1-8.
- Burke, V. J., and E. A. Standora. 1993. Diet of juvenile Kemp's ridley and loggerhead sea turtles from Long Island, New York. *Copeia* 1993(4):1176-1180.
- Bushnoe, T. M., J. A. Musick, and D. S. Ha. 2005. Essential spawning and nursery habitat of Atlantic sturgeon (*Acipenser oxyrinchus*) in Virginia. Virginia Institute of Marine Science, Gloucester Point, Virginia.
- Butterworth, A., I. Clegg, and C. Bass. 2012. *Untangled – Marine debris: a global picture of the impact on animal welfare and of animal-focused solutions*. World Society for the Protection of Animals, London.
- Caillouet, C. W., and coauthors. 2018. Did Declining Carrying Capacity for the Kemp's Ridley Sea Turtle Population Within the Gulf of Mexico Contribute to the Nesting Setback in 2010-2017? *Chelonian Conservation and Biology* 17(1).
- Calvo, L., and coauthors. 2010. Effects of Flow Dynamics, Salinity, and Water Quality on the Atlantic Sturgeon, the Shortnose Sturgeon and the Eastern Oyster in the Oligohaline Zone of the Delaware Estuary. Final Report to USACE, Philadelphia District.
- Cañadillas, B., and coauthors. 2020. Offshore wind farm wake recovery: Airborne measurements and its representation in engineering models. *Wind Energy* 23(5):1249-1265.
- Caron, F., D. Hatin, and R. Fortin. 2002. Biological characteristics of adult Atlantic sturgeon (*Acipenser oxyrinchus*) in the St Lawrence River estuary and the effectiveness of management rules. *Journal of Applied Ichthyology* 18(4-6):580-585.
- Carpenter, J. R., and coauthors. 2016. Potential impacts of offshore wind farms on North Sea stratification. *PLOS ONE* 11(8):e0160830.
- Carr, A. 1987. Impact of nondegradable marine debris on the ecology and survival outlook of sea turtles. *Marine Pollution Bulletin* 18(6B):352-356.

- Carreras, C., and coauthors. 2013. Contextualising the Last Survivors: Population Structure of Marine Turtles in the Dominican Republic. *PLOS ONE* 8(6).
- Carretta, J. 2021. Fin Whale (*Balaenoptera physalus velifera*): California/Oregon/Washington Stock. Pages 196-203 *in* Pacific Marine Mammal Stock Assessments 2020 Final.
- Carretta, J. V., and coauthors. 2019a. U.S. Pacific Marine Mammal Stock Assessments: 2018.
- Carretta, J. V., and coauthors. 2018. U.S. Pacific Marine Mammal Stock Assessments: 2017. Southwest Fisheries Science Center, National Marine Fisheries Service, National Oceanic and Atmospheric Administration, U.S. Department of Commerce, NOAA-TM-NMFS-SWFSC-602, La Jolla, California.
- Carretta, J. V., and coauthors. 2019b. Sources of Human-related Injury and Mortality for U.S. Pacific West Coast Marine Mammal Stock Assessments, 2013-2017. Southwest Fisheries Science Center, National Marine Fisheries Service, National Oceanic and Atmospheric Administration, U.S. Department of Commerce, NOAA-TM-NMFS-SWFSC-616, La Jolla, California.
- Casale, P., and A. D. Tucker. 2017. *Caretta caretta* (amended version of 2015 assessment). The IUCN Red List of Threatened Species 2017:e.T3897A119333622, <http://doi.org/10.2305/IUCN.UK.2017-2.RLTS.T3897A119333622>.
- Cassoff, R. M., and coauthors. 2011. Lethal entanglement in baleen whales. *Diseases of Aquatic Organisms* 96(3):175-185.
- Castelao, R., S. Glenn, and O. Schofield. 2010. Temperature, salinity, and density variability in the central Middle Atlantic Bight. *Journal of Geophysical Research-Oceans* 115(C10).
- Cattanach, K. L., J. Sigurjonsson, S. T. Buckland, and T. Gunnlaugsson. 1993. Sei whale abundance in the North Atlantic, estimated from NASS-87 and NASS-89 data. *Report of the International Whaling Commission* 43:315-321.
- Cazenave, P. W., R. Torres, and J. I. Allen. 2016. Unstructured grid modelling of offshore wind farm impacts on seasonally stratified shelf seas. *Progress in Oceanography* 145:25-41.
- Cerchio, S., S. Strindberg, T. Collins, C. Bennett, and H. Rosenbaum. 2014. Seismic surveys negatively affect humpback whale singing activity off northern Angola. *PLOS ONE* 9(3):e86464.
- Ceriani, S., P. Casale, M. Borst, E. Leone, and B. Witherington. 2019. Conservation implications of sea turtle nesting trends: elusive recovery of a globally important loggerhead population. *Ecosphere* 10(11):19.
- Ceriani, S., and A. Meylan. 2017. *Caretta caretta* North West Atlantic subpopulation (amended version of 2015 assessment). The IUCN Red List of Threatened Species 2017:e.T84131194A119339029. <http://dx.doi.org/10.2305/IUCN.UK.2017-2.RLTS.T84131194A119339029.en>.
- Ceriani, S. A., B. Brost, A. B. Meylan, P. A. Meylan, and P. Casale. 2021. Bias in sea turtle productivity estimates: error and factors involved. *Marine Biology* 168(4):41.
- CETAP. 1982. A characterization of marine mammals and turtles in the mid- and north-Atlantic areas of the U.S. Outer Continental Shelf. Cetacean and Turtle Assessment Program, Bureau of Land Management, BLM/YL/TR-82/03, Washington, D. C.
- Chaloupka, M., and coauthors. 2008. Encouraging outlook for recovery of a once severely exploited marine megaherbivore. *Global Ecology and Biogeography* 17(2):297-304.
- Chaloupka, M. Y., and G. R. Zug. 1997. A polyphasic growth function for the endangered Kemp's ridley sea turtle, *Lepidochelys kempii*. *Fishery Bulletin* 95:849-856.
- Chapman, N. R., and A. Price. 2011. Low frequency deep ocean ambient noise trend in the Northeast Pacific Ocean. *Journal of the Acoustical Society of America* 129(5):EL161-EL165.
- Checkley, D. M., S. Raman, G. L. Maillet, and K. M. Mason. 1988. Winter storm effects on the spawning and larval drift of a pelagic fish. *Nature* 335(6188):346-348.



- Chen, C., R. C. Beardsley, J. Qi, and H. Lin. 2016. Use of finite-volume modeling and the Northeast coastal ocean forecast system in offshore wind energy resource planning. Pages 131 in O. o. R. E. P. Bureau of Ocean Energy Management, editor. U.S. Department of the Interior.
- Chen, Z., E. Curchitser, R. Chant, and D. Kang. 2018. Seasonal variability of the Cold Pool over the Mid-Atlantic Bight continental shelf. *Journal of Geophysical Research: Oceans* 123(11):8203-8226.
- Christiansen, F., and coauthors. 2020. Population comparison of right whale body condition reveals poor state of the North Atlantic right whale. *Marine Ecology Progress Series* 640:16-Jan.
- Christiansen, M. B., and C. B. Hasager. 2005. Wake effects of large offshore wind farms identified from satellite SAR. *Remote Sensing of Environment* 98(2):251-268.
- Christiansen, N., U. Daewel, B. Djath, and C. Schrum. 2022. Emergence of large-scale hydrodynamic structures due to atmospheric offshore wind farm wakes. *Frontiers in Marine Science* 9.
- Clapham, P. J., S. B. Young, and R. L. Brownell Jr. 1999. Baleen whales: Conservation issues and the status of the most endangered populations. *Mammal Review* 29(1):35-60.
- Clark, C. W., and coauthors. 2009. Acoustic masking in marine ecosystems: Intuitions, analysis, and implication. *Marine Ecology Progress Series* 395:201-222.
- Clarke, R. 1956. Sperm whales of the Azores. *Discovery Reports* 28:237-298.
- Cole, T. V. N., P. Duley, M. Foster, A. Henry, and D. D. Morin. 2016. 2015 right whale aerial surveys of the Scotian Shelf and Gulf of St. Lawrence. Northeast Fisheries Science Center Reference Document 16-02. US Department of Commerce, Northeast Fisheries Science Center, Woods Hole, MA.
- Cole, T. V. N., and coauthors. 2013. Evidence of a North Atlantic right whale *Eubalaena glacialis* mating ground. *Endangered Species Research* 21(1):55-64.
- Coles, R. J. 1916. Natural history notes on the devilfish, *Manta birostris* (Walbaum) and *Mobula olfersi* (Müller). *Bulletin of the AMNH. Bulletin of the American Museum of Natural History* 35(33).
- Colette, B., and G. Klein-MacPhee. 2002. *Bigelow and Schroeder's Fishes of the Gulf of Maine*. Smithsonian Institution Press, Washington, DC.
- Collins, M. R., C. Norwood, and A. Rourk. 2008. Shortnose and Atlantic sturgeon age-growth, status, diet, and genetics (2006-0087-009): October 25, 2006 - June 1, 2008 final report. South Carolina Department of Natural Resources.
- Collins, M. R., S. G. Rogers, T. I. J. Smith, and M. L. Moser. 2000a. Primary factors affecting sturgeon populations in the southeastern United States: Fishing mortality and degradation of essential habitats. *Bulletin of Marine Science* 66(3):917-928.
- Collins, M. R., and T. I. J. Smith. 1997. Distributions of shortnose and Atlantic sturgeons in South Carolina. *North American Journal of Fisheries Management* 17(4):955-1000.
- Collins, M. R., T. I. J. Smith, W. C. Post, and O. Pashuk. 2000b. Habitat utilization and biological characteristics of adult Atlantic sturgeon in two South Carolina Rivers. *Transactions of the American Fisheries Society* 129(4):982-988.
- Conant, T. a., and coauthors. 2009. Loggerhead sea turtle (*Caretta caretta*) 2009 status review under the U.S. Endangered Species Act. Report of the Loggerhead Biological Review Team to the National Marine Fisheries Service Aug-09:222 pages.
- Conn, P. B., and G. K. Silber. 2013. Vessel speed restrictions reduce risk of collision-related mortality for North Atlantic right whales. *Ecosphere* 4(4).
- Constantine, R. 2001. Increased avoidance of swimmers by wild bottlenose dolphins (*Tursiops truncatus*) due to long-term exposure to swim-with-dolphin tourism. *Marine Mammal Science* 17(4):689-702.
- Cook, M., V. S. Dunch, and A. T. Coleman. 2020. An Interview-Based Approach to Assess Angler Practices and Sea Turtle Captures on Mississippi Fishing Piers. *Frontiers in Marine Science* 7.

- Cook, R. R., and P. J. Auster. 2007. A Bioregional Classification of the Continental Shelf of Northeastern North America for Conservation Analysis and Planning Based on Representation. Marine Sanctuaries Conservation Series NMSP-07-03. U.S. Department of Commerce, National Oceanic and Atmospheric Administration, National Marine Sanctuary Program, Silver Spring, MD.
- Cooke, J. G. 2018a. *Balaenoptera borealis*. The IUCN Red List of Threatened Species 2018: e.T2475A130482064. <https://dx.doi.org/10.2305/IUCN.UK.2018-2.RLTS.T2475A130482064.en>.
- Cooke, J. G. 2018b. *Balaenoptera physalus*. The IUCN Red List of Threatened Species 2018: e.T2478A50349982. <https://dx.doi.org/10.2305/IUCN.UK.2018-2.RLTS.T2478A50349982.en>.
- Coolen, J. W. P., and coauthors. 2018. RECON: Reef effect structures in the North Sea, islands or connections? Summary report. Wageningen Marine Research rapport; No. C074/17A. Wageningen Marine Research.
- Corkeron, P., and coauthors. 2018. The recovery of North Atlantic right whales, *Eubalaena glacialis*, has been constrained by human-caused mortality. *Royal Society Open Science* 5(11):180892.
- Couturier, L. I., and coauthors. 2012. Biology, ecology and conservation of the Mobulidae. *Journal of Fish Biology* 80(5):1075-1119.
- Cowen, R. K., J. A. Hare, and M. P. Fahay. 1993. Beyond Hydrography: Can Physical Processes Explain Larval Fish Assemblages within the Middle Atlantic Bight? *Bulletin of Marine Science* 53(2):567-587.
- Crance, J. H. 1987. Guidelines for using the delphi technique to develop habitat suitability index curves. U.S. Fish and Wildlife Service, Washington, D. C.
- Croce, B., and R. M. Stagg. 1997. Exposure of Atlantic salmon parr (*Salmo salar*) to a combination of resin acids and a water soluble fraction of diesel fuel oil: A model to investigate the chemical causes of Pigmented Salmon Syndrome. *Environmental Toxicology and Chemistry* 16(9):1921-1929.
- Crocker, S. E., and F. D. Fratantonio. 2016. Characteristics of sounds emitted during high-resolution marine geophysical surveys. Naval Undersea Warfare Center Division, Newport, Rhode Island.
- Cronin, T. W., and coauthors. 2017. Coping with copepods: do right whales (*Eubalaena glacialis*) forage visually in dark waters? *Philos Trans R Soc Lond B Biol Sci* 372(1717).
- CSA. 2021. Request for an Incidental Harassment Authorization to Allow Harassment of Marine Mammals Incidental to Activities Associated with South Fork Wind Farm and Export Cable Construction. BOEM Lease OCS-A 0517. CSA Ocean Sciences Inc for South Fork Wind LLC.
- Dadswell, M. J. 2006. A Review of the status of Atlantic sturgeon in Canada, with comparisons to populations in the United States and Europe. *Fisheries* 31(5):218-229.
- Daewel, U., N. Akhtar, N. Christiansen, and C. Schrum. 2022. Offshore Wind Wakes - the underrated impact on the marine ecosystem. Preprint from Research Square.
- Danielsdottir, A. K., E. J. Duke, P. Joyce, and A. Arnason. 1991. Preliminary studies on genetic variation at enzyme loci in fin whales (*Balaenoptera physalus*) and sei whales (*Balaenoptera borealis*) from the North Atlantic. Report of the International Whaling Commission Special Issue 13:115-124.
- Daoust, P.-Y., E. L. Couture, T. Wimmer, and L. Bourque. 2018. Incident Report: North Atlantic Right Whale Mortality Event in the Gulf of St. Lawrence, 2017. Collaborative Report Produced by: Canadian Wildlife Health Cooperative, Marine Animal Response Society, and Fisheries and Oceans Canada, [http://www.cwhc-rcsf.ca/docs/technical\\_reports/NARW\\_Incident\\_Report-%2020180405%20MD.pdf](http://www.cwhc-rcsf.ca/docs/technical_reports/NARW_Incident_Report-%2020180405%20MD.pdf).
- Davies, K. T. A., and S. W. Brillant. 2019. Mass human-caused mortality spurs federal action to protect endangered North Atlantic right whales in Canada. *Marine Policy* 104:157-162.
- Davies, K. T. A., and coauthors. 2019. Variation in North Atlantic right whale *Eubalaena glacialis* occurrence in the Bay of Fundy, Canada, over three decades. *Endangered Species Research* 39:159-171.
- Davis, G. E., and coauthors. 2017a. Long-term passive acoustic recordings track the changing distribution of North Atlantic right whales (*Eubalaena glacialis*) from 2004 to 2014. *Sci Rep* 7(1):13460.

- Davis, G. E., and coauthors. 2017b. Long-term passive acoustic recordings track the changing distribution of North Atlantic right whales (*Eubalaena glacialis*) from 2004 to 2014. *Scientific Reports* 7(1):13460.
- Davis, R. W., and coauthors. 2007. Diving behavior of sperm whales in relation to behavior of a major prey species, the jumbo squid, in the Gulf of California, Mexico. *Marine Ecology Progress Series* 333:291-302.
- Deakos, M. H. 2010. Paired-laser photogrammetry as a simple and accurate system for measuring the body size of free-ranging manta rays *Manta alfredi*. *Aquatic Biology* 10(1):1-10.
- Deakos, M. H., J. D. Baker, and L. Bejder. 2011. Characteristics of a manta ray *Manta alfredi* -population off Maui, Hawaii, and implications for management. *Marine Ecology Progress Series* 429:245-260.
- Denes, S. L., D. G. Zeddies, and M. M. Weirathmueller. 2020. Turbine Foundation and Cable Installation at South Fork Wind Farm: Underwater Acoustic Modeling of Construction Noise. Document 01584, Version 4.0. Technical report. JASCO Applied Sciences for Jacobs Engineering Group Inc. 5.
- Denes, S. L., D. G. Zeddies, and M. M. Weirathmueller. 2021. Turbine Foundation and Cable Installation at South Fork Wind Farm: Underwater Acoustic Modeling of Construction Noise. Document 01584, Version 4.0. JASCO Applied Sciences for Jacobs Engineering Group Inc.
- Derraik, J. G. B. 2002. The pollution of the marine environment by plastic debris: A review. *Marine Pollution Bulletin* 44(9):842-852.
- Devine, L., and coauthors. 2017. Chemical and Biological Oceanographic Conditions in the Estuary and Gulf of St. Lawrence During 2015. Canadian Science Advisory Secretariat, Research Document 2017/034.
- DFO. 2013. Gulf of St. Lawrence Integrated Management Plan. No. DFO/2013-1898. Department of Fisheries and Ocean Canada, Quebec, Gulf and Newfoundland and Labrador Regions.
- DFO. 2014. Recovery strategy for the North Atlantic right whale (*Eubalaena glacialis*) in Atlantic Canadian Waters [Final]. Species at Risk Act Recovery Strategy Series. Fisheries and Oceans Canada, Ottawa.
- DFO. 2021. Action Plan for the North Atlantic Right Whale (*Eubalaena glacialis*) in Canada. Species at Risk Act Action Plan Series. Fisheries and Oceans Canada, Ottawa.
- Di Iorio, L., and C. W. Clark. 2010. Exposure to seismic survey alters blue whale acoustic communication. *Biology Letters* 6(1):51-54.
- DiJohnson, A. M. 2019. Atlantic Sturgeon (*Acipenser oxyrinchus oxyrinchus*) behavioral responses to vessel traffic and habitat use in the Delaware River, USA. Delaware State University, Dover, Delaware.
- Dodd Jr., C. K. 1988. Synopsis of the biological data on the loggerhead sea turtle *Caretta caretta* (Linnaeus 1758). U.S. Fish and Wildlife Service, 88(14).
- Dodge, K. L., B. Galuardi, and M. E. Lutcavage. 2015. Orientation behaviour of leatherback sea turtles within the North Atlantic subtropical gyre. *Proceedings of the Royal Society of London: Biological Sciences* 282(1804).
- Dodge, K. L., J. M. Logan, and M. E. Lutcavage. 2011. Foraging ecology of leatherback sea turtles in the Western North Atlantic determined through multi-tissue stable isotope analyses. *Marine Biology* 158(12):2813-2824.
- Dominion Energy. 2022. Construction and Operations Plan, Coastal Virginia Offshore Wind Commercial Project. Prepared by Tetra Tech, Inc. Submitted to Bureau of Ocean Energy Management.
- Dominion Energy. 2023. Construction and Operations Plan Coastal Virginia Offshore Wind Commercial Project. Prepared by Tetra Tech, Inc.
- Donaton, J., K. Durham, R. Cerrato, J. Schwerzmann, and L. H. Thorne. 2019. Long-term changes in loggerhead sea turtle diet indicate shifts in the benthic community associated with warming temperatures. *Estuarine Coastal and Shelf Science* 218:139-147.
- Doney, S. C., and coauthors. 2012. Climate change impacts on marine ecosystems. *Marine Science* 4.
- Donovan, G. P. 1991. A review of IWC stock boundaries. *Special Issue* 13:39-68.

- Dorrell, R. M., and coauthors. 2022. Anthropogenic mixing in seasonally stratified shelf seas by offshore wind farm infrastructure. *Frontiers in Marine Science* 9.
- Dovel, W. L., and T. J. Berggren. 1983. Atlantic sturgeon of the Hudson Estuary, New York. *New York Fish and Game Journal* 30(2):140-172.
- Dunlop, R. A. 2016. The effect of vessel noise on humpback whale, *Megaptera novaeangliae*, communication behaviour. *Animal Behaviour* 111:13-21.
- Dunton, K. J., and coauthors. 2012. Genetic mixed-stock analysis of Atlantic sturgeon *Acipenser oxyrinchus oxyrinchus* in a heavily exploited marine habitat indicates the need for routine genetic monitoring. *Journal of Fish Biology* 80(1):207-17.
- Dunton, K. J., and coauthors. 2015. Marine distribution and habitat use of Atlantic sturgeon in New York lead to fisheries interactions and bycatch. *Marine and Coastal Fisheries* 7(1):18-32.
- Dunton, K. J., A. Jordaan, K. A. McKown, D. O. Conover, and M. G. Frisk. 2010. Abundance and distribution of Atlantic sturgeon (*Acipenser oxyrinchus*) within the Northwest Atlantic Ocean, determined from five fishery-independent surveys. *Fishery Bulletin* 108(4):450+.
- Dutton, P. H., B. W. Bowen, D. W. Owens, A. Barragan, and S. K. Davis. 1999. Global phylogeography of the leatherback turtle (*Dermochelys coriacea*). *Journal of Zoology* 248:397-409.
- Dutton, P. H., V. Pease, and D. Shaver. 2006. Characterization of mtDNA variation among Kemp's ridleys nesting on Padre Island with reference to Rancho Nuevo genetic stock. Pages 189 in *Twenty-Sixth Annual Conference on Sea Turtle Conservation and Biology*.
- Dutton, P. H., and coauthors. 2013. Population stock structure of leatherback turtles (*Dermochelys coriacea*) in the Atlantic revealed using mtDNA and microsatellite markers. *Conservation Genetics* 14(3):625-636.
- Eckert, K., B. Wallace, J. Spotila, and B. Bell. 2015. Nesting, ecology, and reproduction. Pages 63 in J. Spotila, and P. Santidrián Tomillo, editors. *The leatherback turtle: biology and conservation*. Johns Hopkins University Press, Baltimore, Maryland.
- Eckert, K. L., B.P. Wallace, J.G. Frazier, S.A. Eckert, and P.C.H. Pritchard. 2012. Synopsis of the Biological Data on the Leatherback Sea Turtle (*Dermochelys Coriacea*). U.S. Department of Interior, Fish and Wildlife Service, Washington, D.C. .
- Eckert, K. L., B. P. Wallace, J. G. Frazier, S. A. Eckert, and P. C. H. Pritchard. 2012. Synopsis of the Biological Data on the Leatherback Sea Turtle (*Dermochelys coriacea*). Biological Technical Publication BTP-R4015-2012. U.S. Fish & Wildlife Service.
- Eckert, S. 2002. Distribution of juvenile leatherback sea turtle *Dermochelys coriacea* sightings. *Marine Ecology Progress Series* 230:289-293.
- Eckert, S. 2013. An assessment of population size and status of Trinidad's leatherback sea turtle nesting colonies. WIDECAS Information Document No. 2013-01. .
- Eckert, S. A. 2006. High-use oceanic areas for Atlantic leatherback sea turtles (*Dermochelys coriacea*) as identified using satellite telemetered location and dive information. *Marine Biology* 149(5):1257-1267.
- Ehrhart, L., W. Redfoot, D. Bagley, and K. Mansfield. 2014. Long-term trends in loggerhead (*Caretta caretta*) nesting and reproductive success at an important western Atlantic rookery. *Chelonian Conservation and Biology* 13(2):173-181.
- Ehrhart, L. M., D. A. Bagley, and W. E. Redfoot. 2003. Loggerhead turtles in the Atlantic Ocean: Geographic distribution, abundance, and population status. Pages 157-174 in A. B. B. E. W. Bolten, editor. *Loggerhead Sea Turtles*. Smithsonian Institution Press, Washington, D. C.
- Elliott, J., and coauthors. 2019. Field Observations during Wind Turbine Operations at the Block Island Wind Farm, Rhode Island. OCS Study BOEM 2019-028. U.S. Department of the Interior, Bureau of Ocean Energy Management, Office of Renewable Energy Programs.

- Ellison, W. T., B. L. Southall, C. W. Clark, and A. S. Frankel. 2011. A new context-based approach to assess marine mammal behavioral responses to anthropogenic sounds. *Conservation Biology*.
- Engås, A., E. K. Haugland, and J. T. Øvredal. 1998. Reactions of cod (*Gadus morhua* L.) in the pre-vessel zone to an approaching trawler under different light conditions. *Hydrobiologia* 371(0):199-206.
- Engås, A., O. A. Misund, A. V. Soldal, B. Horvei, and A. Solstad. 1995. Reactions of penned herring and cod to playback of original, frequency-filtered and time-smoothed vessel sound. *Fisheries Research* 22(3):243-254.
- Engelhaupt, D., and coauthors. 2009. Female philopatry in coastal basins and male dispersion across the North Atlantic in a highly mobile marine species, the sperm whale (*Physeter macrocephalus*). *Molecular Ecology* 18(20):4193-4205.
- EPA. 2012. National Coastal Condition Report IV. Pages 298 *in*. Environmental Protection Agency, Washington, DC.
- Epperly, S. P., and coauthors. 1996. Beach strandings as an indicator of at-sea mortality of sea turtles. *Bulletin of Marine Science* 59(2):289-297.
- Epperly, S. P., and coauthors. 2013. Mortality rates of Kemp's ridley sea turtles in the neritic waters of the United States. Page 219 in (compilers). Proceedings of the .. T. Tucker, and coeditors, editors. Thirty-Third Annual Symposium of Sea Turtle Biology and Conservation.
- EPRI. 2013. EPRI Workshop on EMF and Aquatic Life. 3002000477 Final Report. Electric Power Research Institute, Palo Alto, CA.
- Erbe, C. 2002. Underwater noise of whale-watching boats and potential effects on killer whales (*Orcinus orca*), based on an acoustic impact model. *Marine Mammal Science* 18(2):394-418.
- Erickson, D. L., and coauthors. 2011. Use of pop-up satellite archival tags to identify oceanic-migratory patterns for adult Atlantic sturgeon, *Acipenser oxyrinchus oxyrinchus* Mitchell, 1815. *Journal of Applied Ichthyology* 27(2):356-365.
- Evans, P. G. H., and A. Bjørge. 2013. Impacts of climate change on marine mammals. *Marine Climate Change Impacts Partnership: Science Review*:134-148.
- Exponent Engineering, P. C. 2018. Deepwater Wind South Fork Wind Farm Onshore Electric and Magnetic Field Assessment. Appendix K2 in the South Fork Wind Farm Construction and Operations Plan. Prepared for Deepwater Wind, LLC.
- Fabry, V. J., B. A. Seibel, R. A. Feely, and J. C. Orr. 2008. Impacts of ocean acidification on marine fauna and ecosystem processes. *Journal of Marine Science* 65(3):414-432.
- Farmer, N. A., and coauthors. 2022. The distribution of manta rays in the western North Atlantic Ocean off the eastern United States. *Sci Rep* 12(1):6544.
- Farmer, N. A., and coauthors. 2021. The Distribution of Giant Manta Rays In The Western North Atlantic Ocean Off The Eastern United States. *Research Square*:38.
- Fasick, J. I., M. F. Baumgartner, T. W. Cronin, B. Nickle, and L. J. Kezmoh. 2017. Visual predation during springtime foraging of the North Atlantic right whale (*Eubalaena glacialis*). *Marine Mammal Science*.
- Fay, C., and coauthors. 2006. Status review for anadromous Atlantic salmon (*Salmo salar*) in the United States. National Marine Fisheries Service and U.S. Fish and Wildlife Service.
- Fernandes, S. J., G. B. Zydlewski, J. D. Zydlewski, G. S. Wippelhauser, and M. T. Kinnison. 2010. Seasonal distribution and movements of shortnose sturgeon and Atlantic sturgeon in the Penobscot River Estuary, Maine. *Transactions of the American Fisheries Society* 139(5):1436-1449.
- FFWCC. 2018. Trends in Nesting by Florida Loggerheads. Florida Fish and Wildlife Conservation Commission, <http://myfwc.com/research/wildlife/sea-turtles/nesting/loggerhead-trend/>.
- FFWCC. 2023. Trends in Nesting by Florida Loggerheads. Florida Fish and Wildlife Conservation Commission, <https://myfwc.com/research/about/turtle-nesting/>.

- FHWG. 2008. Memorandum of agreement in principle for interim criteria for injury to fish from pile driving. California Department of Transportation and Federal Highway Administration, Fisheries Hydroacoustic Working Group.
- Finkbeiner, E. M., and coauthors. 2011. Cumulative estimates of sea turtle bycatch and mortality in USA fisheries between 1990 and 2007. *Biological Conservation* 144(11):2719-2727.
- Finneran, J., and coauthors. 2017. Criteria and Thresholds for US Navy Acoustic and Explosive Effects Analysis (Phase III). Technical Report. Space and Naval Warfare Systems Center Pacific (SSC Pacific).
- Finneran, J. J. 2015. Noise-induced hearing loss in marine mammals: A review of temporary threshold shift studies from 1996 to 2015. *Journal of the Acoustical Society of America* 138(3):1702-1726.
- Fisher, M. 2009. Atlantic sturgeon final progress report. Period December 16, 2008 to December 15, 2009. Report No. T-4-1. Delaware Division of Fish and Wildlife, Department of Natural Resources and Environmental Control, Smyrna, Delaware.
- Fisher, M. 2011. Atlantic Sturgeon Final Report. Period October 1, 2006 to October 15, 2010. Report No. T-4-1. Delaware Division of Fish and Wildlife, Department of Natural Resources and Environmental Control, Smyrna, Delaware.
- Fitch, A. C., and coauthors. 2012. Local and mesoscale impacts of wind farms as parameterized in a mesoscale NWP model. *Monthly Weather Review* 140(9):3017-3038.
- Floeter, J., T. Pohlmann, A. Harmer, and C. Möllmann. 2022. Chasing the offshore wind farm wind-wake-induced upwelling/downwelling dipole. *Frontiers in Marine Science* 9.
- Floeter, J., and coauthors. 2017. Pelagic effects of offshore wind farm foundations in the stratified North Sea. *Progress in Oceanography* 156:154-173.
- Foley, A. M., and coauthors. 2019. Characterizing Watercraft-Related Mortality of Sea Turtles in Florida. *The Journal of Wildlife Management*.
- Forster, R. M. 2018. The effect of monopile-induced turbulence on local suspended sediment pattern around UK wind farms: Field survey report. Prepared for The Crown Estate by the Institute of Estuarine and Coastal Studies, University of Hull.
- Fortune, S. M. E., A. W. Trites, C. A. Mayo, D. A. S. Rosen, and P. K. Hamilton. 2013. Energetic requirements of North Atlantic right whales and the implications for species recovery. *Marine Ecology Progress Series* 478:253-272.
- Fortune, S. M. E., and coauthors. 2012. Growth and rapid early development of North Atlantic right whales (*Eubalaena glacialis*). *Journal of Mammalogy* 93(5):1342-1354.
- Fox, D. A., E. A. Hale, and J. A. Sweka. 2020. Examination of Atlantic sturgeon vessel strikes in the Delaware River Estuary. Final Report. Delaware State University, Dover, Delaware.
- Frasier, T. R., and coauthors. 2013. Postcopulatory selection for dissimilar gametes maintains heterozygosity in the endangered North Atlantic right whale. *Ecology and Evolution* 3(10):3483-3494.
- Frazer, N. B., and L. M. Ehrhart. 1985. Preliminary growth models for green, (*Chelonia mydas*) and loggerhead, (*Caretta caretta*), turtles in the wild. *Copeia* 1985(1):73-79.
- Free, S. P. P., F. J. Hernandez, R. H. Condon, J. M. Drymon, and C. M. 2013. Novel pathways for injury from offshore oil spills: Direct, sublethal and indirect effects of the Deepwater Horizon oil spill on pelagic Sargassum communities. *PLOS ONE* 8(9-Jan):e74802.
- Friedland, K. D., and coauthors. 2021. Resource occurrence and productivity in existing and proposed wind energy lease areas on the northeast us shelf. *Frontiers in Marine Science* 8(336).
- Fritts, M. W., C. Grunwald, I. Wirgin, T. L. King, and D. L. Peterson. 2016. Status and Genetic Character of Atlantic Sturgeon in the Satilla River, Georgia. *Transactions of the American Fisheries Society* 145(1):69-82.

- Fujiwara, M., and H. Caswell. 2001. Demography of the endangered North Atlantic right whale. *Nature* 414(6863):537-541.
- Fulling, G., K. Mullin, and C. Hubard. 2003. Abundance and distribution of cetaceans in continental shelf waters of the northern Gulf of Mexico. Pages 56 *in* Fifteenth Biennial Conference on the Biology of Marine Mammals, Greensboro, North Carolina.
- Gabriele, C., B. Kipple, and C. Erbe. 2003. Underwater acoustic monitoring and estimated effects of vessel noise on humpback whales in Glacier Bay, Alaska. Pages 56-57 *in* Fifteenth Biennial Conference on the Biology of Marine Mammals, Greensboro, North Carolina.
- Gall, S. C., and R. C. Thompson. 2015. The impact of debris on marine life. *Marine Pollution Bulletin* 92(2-Jan):170-179.
- Gallo, F., and coauthors. 2018. Marine litter plastics and microplastics and their toxic chemicals components: the need for urgent preventive measures. *Environmental Sciences Europe* 30(1).
- Ganley, L. C., and coauthors. 2022. Effects of changing temperature phenology on the abundance of a critically endangered baleen whale. *Global Ecology and Conservation* 38:e02193.
- Garakouei, M. Y., Z. Pajand, M. Tatina, and H. Khara. 2009. Median Lethal Concentration (LC50) for Suspended Sediments in Two Sturgeon Species, *Acipenser persicus* and *Acipenser stellatus* Fingerlings. *Journal of Fisheries and Aquatic Science* 4(6):285-295.
- Gavrilchuk, K., V. Lesage, S. Fortune, A. W. Trites, and S. Plourde. 2020. A mechanistic approach to predicting suitable foraging habitat for reproductively mature North Atlantic right whales in the Gulf of St. Lawrence. Research Document 2020/034. Canadian Science Advisory Secretariat (CSAS), Quebec Region.
- Gavrilchuk, K., V. Lesage, S. M. E. Fortune, A. W. Trites, and S. Plourde. 2021. Foraging habitat of North Atlantic right whales has declined in the Gulf of St. Lawrence, Canada, and may be insufficient for successful reproduction. *Endangered Species Research* 44:113-136.
- Gilbert, C. R. 1989. Species profiles: Life histories and environmental requirements of coastal fishes and invertebrates (Mid-Atlantic Bight): Atlantic and shortnose sturgeons. U.S. Department of the Interior, Fish and Wildlife Service and U.S. Army Corps of Engineers, Waterways Experiment Station, Washington, D. C.
- Gill, A. B., M. Bartlett, and F. Thomsen. 2012. Potential interactions between diadromous fishes of U.K. conservation importance and the electromagnetic fields and subsea noise from marine renewable energy developments. *Journal of Fish Biology* 81:664-695.
- Gill, A. B., and coauthors. 2020. Setting the context for offshore wind development effects on fish and fisheries. *Oceanography* 33(4):118-127.
- Glass, A. H., T. V. N. Cole, and M. Garron. 2010. Mortality and serious injury determinations for baleen whale stocks along the United States and Canadian Eastern Seaboards, 2004-2008. National Oceanic and Atmospheric Administration, National Marine Fisheries Service, Northeast Fisheries Science Center.
- Glenn, S., and coauthors. 2004. Biogeochemical impact of summertime coastal upwelling on the New Jersey Shelf. *Journal of Geophysical Research: Oceans* 109(C12).
- Glenn, S., and O. Schofield. 2003. Observing the Oceans from the COOL Room: Our History, Experience, and Opinions. *Oceanography* 16(4):37-52.
- Golbazi, M., C. L. Archer, and S. Alessandrini. 2022. Surface impacts of large offshore wind farms. *Environmental Research Letters* 17(6).
- Goldbogen, J. a., and coauthors. 2013. Blue whales respond to simulated mid-frequency military sonar. *Proceedings of the Royal Society B: Biological Sciences* 280(1765):20130657.
- Gomez, C., and coauthors. 2016. A systematic review on the behavioural responses of wild marine mammals to noise: the disparity between science and policy. *Canadian Journal of Zoology*.



- Goold, J. C., and R. F. W. Coates. 2006. Near source, high frequency air-gun signatures. International Whaling Commission.
- Gordon, J., and coauthors. 2003. A Review of the Effects of Seismic Surveys on Marine Mammals. *Marine Technology Society Journal* 37(4):16-34.
- Goshe, L. R., L. Avens, F. S. Scharf, and A. L. Southwood. 2010. Estimation of age at maturation and growth of Atlantic green turtles (*Chelonia mydas*) using skeletochronology. *Marine Biology* 157(8):1725-1740.
- Gotz, T., and coauthors. 2009. Overview of the impacts of anthropogenic underwater sound in the marine environment.
- Graham, I. M., and coauthors. 2017. Responses of bottlenose dolphins and harbor porpoises to impact and vibration piling noise during harbor construction. *Ecosphere* 8(5):e01793.
- Greene, K. E., J. L. Zimmerman, R. W. Laney, and J. C. Thomas-Blate. 2009. Atlantic coast diadromous fish habitat: A review of utilization, threats, recommendations for conservation, and research needs. Atlantic States Marine Fisheries Commission, Washington, DC.
- Greenlee, R., and coauthors. 2019. Assessment of critical habitats for recovering the Chesapeake Bay Atlantic sturgeon distinct population segment—Phase II: A collaborative approach in support of management. Final Report. Virginia Department of Game and Inland Fisheries.
- Grieve, B. D., J. A. Hare, and V. S. Saba. 2017. Projecting the effects of climate change on *Calanus finmarchicus* distribution within the U.S. Northeast Continental Shelf. *Sci Rep* 7(1):6264.
- Groombridge, B. 1982. Kemp's ridley or Atlantic ridley, *Lepidochelys kempii* (Garman 1980). The IUCN Amphibia, Reptilia Red Data Book:201-208.
- Grothues, T. M., and coauthors. 2002. Flux of larval fish around Cape Hatteras. *Limnology and Oceanography* 47(1):165-175.
- Guilbard, F., J. Munro, P. Dumont, D. Hatin, and R. Fortin. 2007. Feeding ecology of Atlantic sturgeon and lake sturgeon co-occurring in the St. Lawrence estuarine transition zone. *American Fisheries Society Symposium* 56:85.
- Hager, C. 2011. Atlantic Sturgeon Review: Gather data on reproducing subpopulation on Atlantic Sturgeon in the James River. Final Report - 09/15/2010 to 9/15/2011. NOAA/NMFS contract EA133F10CN0317 to the James River Association.
- Hager, C. H., J. Kahn, C. Watterson, J. Russo, and Kyle. 2014. Evidence of Atlantic sturgeon spawning in the York River system. *Transactions of the American Fisheries Society* 143(5):1217-1219.
- Hager, C. H., J. C. Watterson, and J. E. Kahn. 2020. Spawning Drivers and Frequency of Endangered Atlantic Sturgeon in the York River System. *Transactions of the American Fisheries Society* 149(4):474-485.
- Hale, E. A., and coauthors. 2016. Abundance Estimate for and Habitat Use by Early Juvenile Atlantic Sturgeon within the Delaware River Estuary. *Transactions of the American Fisheries Society* 145(6):1193-1201.
- Hale, R. 2018. Sounds from Submarine Cable & Pipeline Operations. . [https://www.un.org/depts/los/consultative\\_process/icp19\\_presentations/2.Richard%20Hale.pdf](https://www.un.org/depts/los/consultative_process/icp19_presentations/2.Richard%20Hale.pdf). EGS Survey Group representing the International Cable Protection Committee. United Nations ICP on Oceans and the Law of the Sea.
- Haley, N. 1998. A gastric lavage technique for characterizing diets of sturgeons. *North American Journal of Fisheries Management* 18(4):978-981.
- Haley, N. J. 1999. Habitat characteristics and resource use patterns of sympatric sturgeons in the Hudson River Estuary. University of Massachusetts Amherst.
- Halpin, P., and coauthors. 2009. OBIS-SEAMAP: The World Data Center for Marine Mammal, Sea Bird, and Sea Turtle Distributions. *Oceanography* 22(2):104-115.



- Hamilton, P. K., A. R. Knowlton, M. K. Marx, and S. D. Kraus. 1998. Age structure and longevity in North Atlantic right whales *Eubalaena glacialis* and their relation to reproduction. *Marine Ecology Progress Series* 171:285-292.
- Hare, J. A., and R. K. Cowen. 1996. Transport mechanisms of larval and pelagic juvenile bluefish (*Pomatomus saltatrix*) from South Atlantic Bight spawning grounds to Middle Atlantic Bight nursery habitats. *Limnology and Oceanography* 41(6):1264-1280.
- Hare, J. A., and coauthors. 2016. A vulnerability assessment of fish and invertebrates to climate change on the Northeast US Continental Shelf. *PLoS ONE* 11(2):e0146756.
- Hart, K. M., P. Mooreside, and L. B. Crowder. 2006. Interpreting the spatio-temporal patterns of sea turtle strandings: going with the flow. *Biological Conservation* 129(2):283-290.
- Hastings, R. W. 1983. A study of the shortnose sturgeon (*Acipenser brevirostrum*) population in the upper tidal Delaware River: Assessment of impacts of maintenance dredging. U.S. Army Corps of Engineers, Philadelphia, Pennsylvania.
- Hatin, D., R. Fortin, and F. Caron. 2002. Movements and aggregation areas of adult Atlantic sturgeon (*Acipenser oxyrinchus*) in the St Lawrence River estuary, Quebec, Canada. *Journal of Applied Ichthyology* 18(4-6):586-594.
- Hatin, D. R., S. Lachance, and D. Fournier. 2007. Effect of dredged sediment deposition on use by Atlantic sturgeon (*Acipenser oxyrinchus*) and Lake sturgeon (*Acipenser fulvescens*) at an open-water disposal site in the St. Lawrence Estuarine Transition Zone. Pages 235-255 *in* American Fisheries Society Symposium.
- Haver, S. M., and coauthors. 2019. Comparing the Underwater Soundscapes of Four U.S. National Parks and Marine Sanctuaries. *Frontiers in Marine Science* 6.
- Haver, S. M., and coauthors. 2018. Monitoring long-term soundscape trends in U.S. Waters: The NOAA/NPS Ocean Noise Reference Station Network. *Marine Policy* 90:13-Jun.
- Hayes, S. A., S. Gardner, L. Garrison, A. Henry, and L. Leandro. 2018. North Atlantic Right Whales- Evaluating Their Recovery Challenges in 2018. Northeast Fisheries Science Center, National Marine Fisheries Service, National Oceanic and Atmospheric Administration, U.S. Department of Commerce, NMFS-NE-247, Woods Hole, Massachusetts.
- Hayes, S. A., E. Josephson, K. Maze-Foley, and P. E. Rose. 2019. US Atlantic and Gulf of Mexico Marine Mammal Stock Assessments - 2018. Pages 258 *in*. National Marine Fisheries Service, Northeast Fisheries Science Center.
- Hayes, S. A., E. Josephson, K. Maze-Foley, and P. Rosel. 2022a. Draft U.S. Atlantic and Gulf of Mexico marine mammal stock assessments - 2022. National Marine Fisheries Service, Northeast Fisheries Science Center, Woods Hole, Massachusetts.
- Hayes, S. A., E. Josephson, K. Maze-Foley, and P. E. Rosel. 2017. US Atlantic and Gulf of Mexico Marine Mammal Stock Assessments - 2016. Northeast Fisheries Science Center, National Marine Fisheries Service, National Oceanic and Atmospheric Administration, U.S. Department of Commerce, NOAA-TM-NMFS--NE-241, Woods Hole, Massachusetts.
- Hayes, S. A., E. Josephson, K. Maze-Foley, and P. E. Rosel. 2020. US Atlantic and Gulf of Mexico Marine Mammal Stock Assessments - 2019. Pages 479 *in*. U.S. Department of Commerce, National Oceanic and Atmospheric Administration, National Marine Fisheries Service, Northeast Fisheries Science Center, Woods Hole, Massachusetts.
- Hayes, S. A., and coauthors. 2023. U.S. Atlantic and Gulf of Mexico Marine Mammal Stock Assessments 2022. NOAA Technical Memorandum NMFS-NE-304. National Marine Fisheries Service, Northeast Fisheries Science Center, Woods Hole, Massachusetts.

- Hayes, S. A., E. Josephson, K. Maze-Foley, P. E. Rosel, and J. Turek. 2021. US Atlantic and Gulf of Mexico Marine Mammal Stock Assessments 2020. NOAA Technical Memorandum NMFS-NE-271. National Marine Fisheries Service, Northeast Fisheries Science Center, Woods Hole, Massachusetts.
- Hayes, S. H., E. Josephson, K. Maze-Foley, P. E. Rosel, and J. Wallace. 2022b. U.S. Atlantic and Gulf of Mexico Marine Mammal Stock Assessments 2021. NOAA Technical Memorandum NMFS-NE-288. National Marine Fisheries Service Northeast Fisheries Science Center, Woods Hole, Massachusetts.
- Hayhoe, K., and coauthors. 2018. Our Changing Climate. Pages 72–144 in D. R. Reidmiller, and coeditors, editors. Impacts, Risks, and Adaptation in the United States: Fourth National Climate Assessment, Volume II. U.S. Global Change Research Program, Washington, DC, USA.
- Hays, G. C. 2000. The implications of variable remigration intervals for the assessment of population size in marine turtles. *Journal of Theoretical Biology* 206(2):221-227.
- Hazel, J., and E. Gyuris. 2006. Vessel-related mortality of sea turtles in Queensland, Australia. *Wildlife Research* 33(2):149-154.
- Hazel, J., I. R. Lawler, H. Marsh, and S. Robson. 2007. Vessel speed increases collision risk for the green turtle *Chelonia mydas*. *Endangered Species Research* 3:105-113.
- Hazen, E. L., and coauthors. 2012. Predicted habitat shifts of Pacific top predators in a changing climate. *Nature Climate Change* 3(3):234-238.
- HDR. 2020. Field Observations During Offshore Wind Structure Installation and Operation, Volume I. Final Report to the U.S. Department of the Interior, Bureau of Ocean Energy Management, Office of Renewable Energy Programs. OCS Study BOEM 2021-025.
- Henry, A., and coauthors. 2022. Serious injury and mortality determinations for baleen whale stocks along the Gulf of Mexico, United States East Coast, and Atlantic Canadian Provinces, 2016-2020. C. Northeast Fisheries Science, editor. National Marine Fisheries Service, Northeast Fisheries Science Center, Woods Hole, Massachusetts.
- Heppell, S. S., and coauthors. 2005. A population model to estimate recovery time, population size, and management impacts on Kemp's ridley sea turtles. *Chelonian Conservation and Biology* 4(4):767-773.
- Heppell, S. S., M. L. Snover, and L. Crowder. 2003. Sea turtle population ecology. Pages 275-306 in P. L. J. A. M. J. Wyneken, editor. *The Biology of Sea Turtles*. CRC Press, Boca Raton, Florida.
- Hildebrand, H. 1983. Random notes on sea turtles in the Western Gulf of Mexico. *Western Gulf of Mexico Sea Turtle Workshop* 1983(13-Jan):34-41.
- Hildebrand, J. A. 2009. Anthropogenic and natural sources of ambient noise in the ocean. *Marine Ecology Progress Series* 395:5-20.
- Hilton, E. J., and coauthors. 2016. Review of the biology, fisheries, and conservation status of the Atlantic Sturgeon, (*Acipenser oxyrinchus oxyrinchus* Mitchell, 1815). *Journal of Applied Ichthyology* 32(S1):30-66.
- Hinzmann, N., P. Stein, J. Gattermann, J. Bachmann, and G. Duff. 2017. Measurements of hydro sound emissions during internal jet cutting during monopile decommissioning.
- Hirth, H. F. 1997. Synopsis of the biological data on the green turtle *Chelonia mydas* (Linnaeus 1758). *Biological Report* 91(1):120.
- Hodge, K. B., C. A. Muirhead, J. L. Morano, C. W. Clark, and A. N. Rice. 2015. North Atlantic right whale occurrence near wind energy areas along the mid-Atlantic US coast: Implications for management. *Endangered Species Research* 28(3):225-234.
- Holland, B. F. J., and G. F. Yelverton. 1973. Distribution and biological studies of anadromous fishes offshore North Carolina. N. C. Department Natural Resources Special Science Report: 24.

- Holt, M. M. 2008. Sound exposure and Southern Resident killer whales (*Orcinus orca*): A review of current knowledge and data gaps. National Oceanic and Atmospheric Administration, National Marine Fisheries Service, Northwest Fisheries Science Center.
- Holt, M. M., D. P. Noren, V. Veirs, C. K. Emmons, and S. Veirs. 2009. Speaking up: Killer whales (*Orcinus orca*) increase their call amplitude in response to vessel noise. *Journal of the Acoustical Society of America* 125(1):E127-E132.
- Hooper, T., N. Beaumont, and C. Hattam. 2017. The implications of energy systems for ecosystem services: A detailed case study of offshore wind. *Renewable and Sustainable Energy Reviews* 70:230-241.
- Houghton, R. W., R. Schlitz, R. C. Beardsley, B. Butman, and J. L. Chamberlin. 1982. The Middle Atlantic Bight Cold Pool: Evolution of the Temperature Structure During Summer 1979. *Journal of Physical Oceanography* 12(10):1019-1029.
- Huijser, L. A. E., and coauthors. 2018. Population structure of North Atlantic and North Pacific sei whales (*Balaenoptera borealis*) inferred from mitochondrial control region DNA sequences and microsatellite genotypes. *Conservation Genetics*.
- Hulin, V., V. Delmas, M. Girondot, M. H. Godfrey, and J. M. Guillon. 2009. Temperature-dependent sex determination and global change: Are some species at greater risk? *Oecologia* 160(3):493-506.
- Hutchison, Z. L., and coauthors. 2020. Offshore wind energy and benthic habitat changes: Lessons from Block Island wind farm. *Oceanography* 33(4):58-69.
- Ingram, E. C., R. M. Cerrato, K. J. Dunton, and M. G. Frisk. 2019a. Endangered Atlantic Sturgeon in the New York Wind Energy Area: implications of future development in an offshore wind energy site. *Scientific Reports* 9(1):12432.
- Ingram, E. C., R. M. Cerrato, K. J. Dunton, and M. G. Frisk. 2019b. Endangered Atlantic Sturgeon in the New York Wind Energy Area: implications of future development in an offshore wind energy site. *Scientific Reports* 9.
- IPCC. 2014. *Climate change 2014: Impacts, adaptation, and vulnerability*. IPCC Working Group II contribution to AR5. Intergovernmental Panel on Climate Change.
- IPCC. 2018. *Summary for Policymakers*. V. Masson-Delmotte, and coeditors, editors. *Global Warming of 1.5°C. An IPCC Special Report on the impacts of global warming of 1.5°C above pre-industrial levels and related global greenhouse gas emission pathways, in the context of strengthening the global response to the threat of climate change, sustainable development, and efforts to eradicate poverty*. World Meteorological Organization, Geneva, Switzerland.
- IPCC. 2021. *Summary for Policymakers*. In: *Climate Change 2021: The Physical Science Basis; Contribution of Working Group I to the Sixth Assessment Report of the Intergovernmental Panel on Climate Change*. Cambridge University Press.
- IPCC. 2022. *Climate Change 2022: Impacts, Adaptation and Vulnerability*. Contribution of Working Group II to the Sixth Assessment Report of the Intergovernmental Panel on Climate Change, Cambridge, UK and New York, NY, USA.
- Ischer, T., K. Ireland, and D. T. Booth. 2009. Locomotion performance of green turtle hatchlings from the Heron Island Rookery, Great Barrier Reef. *Marine Biology* 156(7):1399-1409.
- IWC. 2017. *Strategic Plan to Mitigate the Impacts of Ship Strikes on Cetacean Populations: 2017-2020*.
- Jacobsen, K.-O., M. Marx, and N. Øien. 2004. Two-way trans-Atlantic migration of a North Atlantic right whale (*Eubalaena glacialis*). *Marine Mammal Science* 20(1):161-166.
- James, M. C., S. A. Eckert, and R. A. Myers. 2005a. Migratory and reproductive movements of male leatherback turtles (*Dermochelys coriacea*). *Marine Biology* 147(4):845-853.

- James, M. C., R. A. Myers, and C. A. Ottensmeyer. 2005b. Behaviour of leatherback sea turtles, *Dermochelys coriacea*, during the migratory cycle. *Proceedings of the Royal Society Biological Sciences Series B* 272(1572):1547-1555.
- James, M. C., C. A. Ottensmeyer, and R. A. Myers. 2005c. Identification of high-use habitat and threats to leatherback sea turtles in northern waters: New directions for conservation. *Ecology Letters* 8(2):195-201.
- Jansen, E., and C. de Jong. 2016. Underwater noise measurements in the North Sea in and near the Princess Amalia Wind Farm in operation. 45th International Congress and Exposition on Noise Control Engineering: Towards a Quieter Future, INTER-NOISE 2016. 21 August 2016 through 24 August 2016, 7846–7857.
- Jensen, A. S., and G. K. Silber. 2003. Large whale ship strike database. U.S. Department of Commerce, NOAA Technical Memorandum NMFS-F/OPR-25, Silver Spring, Maryland.
- Jensen, A. S., and G. K. Silber. 2004. Large whale ship strike database. National Oceanic and Atmospheric Administration, National Marine Fisheries Service, Office of Protected Resources.
- Johnson, C., E. Devred, B. Casault, E. Head, and J. Spry. 2017. Optical, Chemical, and Biological Oceanographic Conditions on the Scotian Shelf and in the Eastern Gulf of Maine in 2015. Fisheries and Oceans Canada, Science Advisory Secretariat, 53.
- Johnson, J. H., D. S. Dropkin, B. E. Warkentine, J. W. Rachlin, and W. D. Andrews. 1997. Food habits of Atlantic sturgeon off the central New Jersey coast. *Transactions of the American Fisheries Society* 126(1):166-170.
- Johnson, T. L., and coauthors. 2021. Hydrodynamic modeling, particle tracking and agent-based modeling of larvae in the U.S. mid-Atlantic bight. OCS Study BOEM 2021-049. U.S. Department of the Interior, Bureau of Ocean Energy Management, Lakewood, CO.
- Jones, T. T., M. D. Hastings, B. L. Bostrom, D. Pauly, and D. R. Jones. 2011. Growth of captive leatherback turtles, *Dermochelys coriacea*, with inferences on growth in the wild: Implications for population decline and recovery. *Journal of Experimental Marine Biology and Ecology* 399(1):84-92.
- Kahn, J. 2019. Adult Atlantic sturgeon population dynamics in the York River Virginia. University of West Virginia, Morgantown, West Virginia.
- Kahn, J. 2023. Arrival and departure windows of Atlantic sturgeon in Chesapeake Bay in Virginia. [Unpublished manuscript].
- Kahnle, A. W., K. A. Hattala, and K. A. Mckown. 2007. Status of Atlantic sturgeon of the Hudson River Estuary, New York, USA. *American Fisheries Society Symposium* 56:347-363.
- Kahnle, A. W., and coauthors. 1998. Stock status of Atlantic sturgeon of Atlantic coast estuaries. Draft III. Atlantic States Marine Fisheries Commission.
- Kanda, N., M. Goto, K. Matsuoka, H. Yoshida, and L. A. Pastene. 2011. Stock identity of sei whales in the central North Pacific based on microsatellite analysis of biopsy samples obtained from IWC/Japan joint cetacean sighting survey in 2010. IWC Scientific Committee, Tromso, Norway.
- Kanda, N., M. Goto, and L. A. Pastene. 2006. Genetic characteristics of western North Pacific sei whales, *Balaenoptera borealis*, as revealed by microsatellites. *Marine Biotechnology* 8(1):86-93.
- Kanda, N., K. Matsuoka, M. Goto, and L. A. Pastene. 2015. Genetic study on JARPNII and IWC-POWER samples of sei whales collected widely from the North Pacific at the same time of the year. IWC Scientific Committee, San Diego, California.
- Kanda, N., K. Matsuoka, H. Yoshida, and L. A. Pastene. 2013. Microsatellite DNA analysis of sei whales obtained from the 2010-2012 IWC-POWER. IWC Scientific Committee, Jeju, Korea.
- Kane, J. 2005. The demography of *Calanus finmarchicus* (Copepoda: Calanoida) in the Middle Atlantic Bight, USA, 1977–2001. *Journal of Plankton Research* 27(5):401-414.

- Kaplan, B. e. 2011. Literature Synthesis for the North and Central Atlantic Ocean. Pages 447 in R. a. E. Bureau of Ocean Energy Management, Gulf of Mexico OCS Region, editor. U.S. Dept. of the Interior, New Orleans, LA.
- Kazyak, D. C., and coauthors. 2020. Integrating side-scan sonar and acoustic telemetry to estimate the annual spawning run size of Atlantic sturgeon in the Hudson River. *Canadian Journal of Fisheries and Aquatic Sciences* 77(6):1038-1048.
- Kazyak, D. C., S. L. White, B. A. Lubinski, R. Johnson, and M. Eackles. 2021. Stock composition of Atlantic sturgeon (*Acipenser oxyrinchus oxyrinchus*) encountered in marine and estuarine environments on the U.S. Atlantic Coast. *Conservation Genetics*.
- Keinath, J. A., J. A. Musick, and W. M. Swingle. 1991. First verified record of the hawksbill sea turtle (*Eretmochelys imbricata*) in Virginia waters. *Catesbeiana* 11(2):35-38.
- Kelley, D. E., J. P. Vlastic, and S. W. Brilliant. 2020. Assessing the lethality of ship strikes on whales using simple biophysical models. *Marine Mammal Science*.
- Kenney, R. 2013. BLM CETAP AIR Sightings. Data downloaded from OBIS-SEAMAP (<http://seamap.env.duke.edu/dataset/283>) on 2023-08-16.
- Kenney, R. D. 2009. Right whales: *Eubalaena glacialis*, *E. japonica*, and *E. australis*. Pages 962-972 in W. F. P. B. W. J. G. M. Thewissen, editor. *Encyclopedia of Marine Mammals*, Second edition. Academic Press, San Diego, California.
- Kenney, R. D. 2018. What if there were no fishing? North Atlantic right whale population trajectories without entanglement mortality. *Endangered Species Research* 37:233-237.
- Kenney, R. D., and K. J. Vigness-Raposa. 2010. Chapter 10. Marine Mammals and Sea Turtles of Narragansett Bay, Block Island Sound, Rhode Island Sound, and Nearby Waters: An Analysis of Existing Data for the Rhode Island Ocean Special Area Management Plan. RICRMC (Rhode Island Coastal Resources Management Council) Ocean Special Area Management Plan (SAMP), Volume 2. Appendix.
- Kenney, R. D., H. E. Winn, and M. C. Macaulay. 1995. Cetaceans in the Great South Channel, 1979-1989: Right whale (*Eubalaena glacialis*). *Continental Shelf Research* 15(5-Apr):385-414.
- King, T. L., B. A. Lubinski, and A. P. Spidle. 2001. Microsatellite DNA variation in Atlantic sturgeon (*Acipenser oxyrinchus oxyrinchus*) and cross-species amplification in the *Acipenseridae*. *Conservation Genetics* 2(2):103-119.
- Kipple, B., and C. Gabriele. 2003. Glacier Bay watercraft noise. Naval Surface Warfare Center technical report NSWCCD-71-TR-2003/522.
- Kipple, B., and C. Gabriele. 2004. Underwater noise from skiffs to ships. S. M. J. F. G. Piatt, editor *Fourth Glacier Bay Science Symposium*.
- Kirkpatrick, A. J., and coauthors. 2017. Socio-Economic Impact of Outer Continental Shelf Wind Energy Development on Fisheries in the US Atlantic. O. o. R. E. P. Bureau of Ocean Energy Management, editor. U.S. Dept of Interior, Washington, D.C.
- Kirschvink, J. L. 1990. Geomagnetic sensitivity in cetaceans: An update with live stranding records in the Unites States. Pages 639-649 in R. A. J. A. K. Thomas, editor. *Sensory Abilities of Cetaceans: Laboratory and Field Evidence*.
- Kiszka, J. J., and coauthors. 2023. Critically endangered Rice's whales (*Balaenoptera ricei*) selectively feed on high-quality prey in the Gulf of Mexico. *Scientific Reports* 13(1):6710.
- Knowlton, A. R., J. Sigurjónsson, J. N. Ciano, and S. D. Kraus. 1992a. Long-distance movements of North Atlantic right whales (*Eubalaena glacialis*). *Marine Mammal Science* 8(4):397-405.
- Knowlton, A. R., J. Sigurjónsson, J. N. Ciano, and S. D. Kraus. 1992b. Long-distance movements of North Atlantic right whales (*Eubalaena glacialis*). *Marine Mammal Science* 8(4):397-405.

- Koch, V., H. Peckham, A. Mancini, and T. Eguchi. 2013. Estimating at-sea mortality of marine turtles from stranding frequencies and drifter experiments. *PLoS ONE* 8(2):e56776.
- Kocik, J., C. A. Lipsky, T. J. Miller, P. J. Rago, and G. R. Shepherd. 2013. An Atlantic sturgeon population index for ESA management analysis.
- Kohler, N. E., J. G. Casey, and P. A. Turner. 1998. NMFS cooperative shark tagging program, 1962-93: An atlas of shark tag and recapture data. *Marine Fisheries Review* 60(2):Jan-87.
- Kraus, S., and J. J. Hatch. 2001. Mating strategies in the North Atlantic right whale (*Eubalaena glacialis*). *Journal of Cetacean Research and Management* 2:237-244.
- Kraus, S. D., and coauthors. 2005. North Atlantic right whales in crisis. *Science* 309(5734):561-562.
- Kraus, S. D., and coauthors. 2016. Northeast Large Pelagic Survey Collaborative Aerial and Acoustic Surveys for Large Whales and Sea Turtles. OCS Study BOEM 2016-054. US Department of the Interior, Bureau of Ocean Energy Management, Sterling, Virginia.
- Kraus, S. D., R. M. Pace III, and T. R. Frasier. 2007. High investment, low return: The strange case of reproduction in *Eubalaena glacialis*. Pages 172-199 in R. S. D. R. Kraus, editor. *The Urban Whale: North Atlantic Right Whales at the Crossroads*. Harvard University Press, Cambridge, Massachusetts.
- Kremser, U., P. Klemm, and W. D. Kotz. 2005. Estimating the risk of temporary acoustic threshold shift, caused by hydroacoustic devices, in whales in the Southern Ocean. *Antarctic Science* 17(1):10-Mar.
- Krone, R., and coauthors. 2017. Mobile demersal megafauna at common offshore wind turbine foundations in the German Bight (North Sea) two years after deployment - increased production rate of *Cancer pagurus*. *Marine Environmental Research* 123:53-61.
- Krumhansl, K. A., and coauthors. 2018. Environmental drivers of vertical distribution in diapausing *Calanus* copepods in the Northwest Atlantic. *Progress in Oceanography* 162:202-222.
- Krzystan, A. M., and coauthors. 2018. Characterizing residence patterns of North Atlantic right whales in the southeastern USA with a multistate open robust design model. *Endangered Species Research* 36:279-295.
- Kynard, B., and coauthors. 2016. Life history and status of Shortnose Sturgeon (*Acipenser brevirostrum* LeSueur, 1818). *Journal of Applied Ichthyology* 32(S1):208-248.
- Kynard, B., and M. Horgan. 2002. Ontogenetic behavior and migration of Atlantic sturgeon, *Acipenser oxyrinchus oxyrinchus*, and shortnose sturgeon, *A. brevirostrum*, with notes on social behavior. *Environmental Biology of Fishes* 63(2):137-150.
- Kynard, B., M. Horgan, M. Kieffer, and D. Seibel. 2000. Habitats used by shortnose sturgeon in two Massachusetts rivers, with notes on estuarine Atlantic sturgeon: A hierarchical approach. *Transactions of the American Fisheries Society* 129(2):487-503.
- LaCasella, E. L., S. P. Epperly, M. P. Jensen, L. Stokes, and P. H. Dutton. 2013. Genetic stock composition of loggerhead turtles *Caretta caretta* bycaught in the pelagic waters of the North Atlantic. *Endangered Species Research* 22(1):73-84.
- Lagueux, C. J. 2001. Status and distribution of the green turtle, *Chelonia mydas*, in the wider Caribbean region. Pages 32-35 in F. A. K. L. A. G. Eckert, editor *Marine Turtle Conservation in the Wider Caribbean Region - A Dialogue for Effective Regional Management*, Santo Domingo, Dominican Republic.
- Laist, D. W. 1997. Impacts of marine debris: Entanglement of marine life in marine debris including a comprehensive list of species with entanglement and ingestion records. Pages 99-140 in D. B. J. M. R. Coe, editor. *Marine Debris: Sources, Impacts, and Solutions*. Springer-Verlag, New York, New York.
- Laist, D. W., J. M. Coe, and K. J. O'hara. 1999. Marine debris pollution. Pages 342-366 in J. R. R. R. T. Jr., editor. *Conservation and Management of Marine Mammals*. Smithsonian Institution Press, Washington, D. C.

- Laist, D. W., A. R. Knowlton, J. G. Mead, A. S. Collet, and M. Podesta. 2001. Collisions between ships and whales. *Marine Mammal Science* 17(1):35-75.
- Laney, R. W., J. E. Hightower, B. R. Versak, M. F. Mangold, and S. E. Winslow. 2007. Distribution, habitat use, and size of Atlantic sturgeon captured during cooperative winter tagging cruises, 1988-2006. *American Fisheries Society Symposium* 56:167-182.
- Laurent, L., and coauthors. 1998. Molecular resolution of marine turtle stock composition in fishery by-catch: A case study in the Mediterranean. *Molecular Ecology* 7:1529-1542.
- Law, K. L., and coauthors. 2010. Plastic accumulation in the North Atlantic subtropical gyre. *Science* 329(5996):1185-1188.
- Lawson, J. M., and coauthors. 2017. Sympathy for the devil: a conservation strategy for devil and manta rays. *PeerJ* 5:e3027.
- Learmonth, J. A., and coauthors. 2006. Potential effects of climate change on marine mammals. *Oceanography and Marine Biology: an Annual Review* 44:431-464.
- Lee, D. S., and coauthors. 1980. Atlas of North American Freshwater Fishes. North Carolina State Museum of Natural History, Raleigh, North Carolina.
- Lee, D. S., and W. M. Palmer. 1981. Records of leatherback turtles, *Dermochelys coriacea* (Linnaeus) and other marine turtles in North Carolina waters. *Brimleyana* 5:95-106.
- Lehoux, C., S. Plourde, and V. Lesage. 2020. Significance of dominant zooplankton species to the North Atlantic Right Whale potential foraging habitats in the Gulf of St. Lawrence: a bio-energetic approach. Research Document 2020/033. DFO Canadian Science Advisory Secretariat.
- Leiter, S. M., and coauthors. 2017. North Atlantic right whale *Eubalaena glacialis* occurrence in offshore wind energy areas near Massachusetts and Rhode Island, USA. *Endangered Species Research* 34:45-59.
- Leland, J. G. 1968. A survey of the sturgeon fishery of South Carolina. Bears Bluff Laboratories.
- Lenhardt, M. L. 1994. Seismic and very low frequency sound induced behaviors in captive loggerhead marine turtles (*Caretta caretta*). Pages 238-241 in A. B. C. K. A. C. B. Bjorndal, D. A. C. Johnson, and P. J. C. Eliazar, editors. Fourteenth Annual Symposium on Sea Turtle Biology and Conservation.
- Lentz, S. J. 2017. Seasonal warming of the Middle Atlantic Bight Cold Pool. *Journal of Geophysical Research: Oceans* 122(2):941-954.
- Lesage, V., C. Barrette, M. C. S. Kingsley, and B. Sjøre. 1999. The effect of vessel noise on the vocal behavior of Belugas in the St. Lawrence River estuary, Canada. *Marine Mammal Science* 15(1):65-84.
- Lesage, V., K. Gavrilchuk, R. D. Andrews, and R. Sears. 2017. Foraging areas, migratory movements and winter destinations of blue whales from the western North Atlantic. *Endangered Species Research* 34:27-43.
- Li, Y., and coauthors. 2014. Wind-induced interannual variability of sea level slope, along-shelf flow, and surface salinity on the Northwest Atlantic shelf. *Journal of Geophysical Research: Oceans* 119(4):2462-2479.
- Lichter, J., and coauthors. 2006. The ecological collapse and partial recovery of a freshwater tidal ecosystem. *Northeastern Naturalist* 13(2):153-178.
- Lockhart, G. G., R. A. DiGiovanni Jr., and A. M. DePerte. 2014. Virginia and Maryland Sea Turtle Research and Conservation Initiative Aerial Survey Sightings, May 2011 through July 2013. Downloaded from OBIS-SEAMAP (<http://seamap.env.duke.edu/dataset/1201>).
- Lockyer, C. 1984. Review of baleen whale (Mysticeti) reproduction and implications for management. Report of the International Whaling Commission Special Issue 6:27-50.
- Lohmann, K. J., B. E. Witherington, C. M. Lohmann, and M. Salmon. 1997. Orientation, navigation, and natal beach homing. Pages 107-135 in *The biology of sea turtles*. CRC Press Florida.



- Lohofener, R. R., W. Hoggard, K. Mullin, C. Roden, and C. Rogers. 1990. Association of sea turtles with petroleum platforms in the north-central Gulf of Mexico. Minerals Management Service.
- Ludewig, E. 2015. On the effect of offshore wind farms on the atmosphere and ocean dynamics. Hamburg Studies on Maritime Affairs 31. Springer Verlag.
- Lutcavage, M. E., P. Plotkin, B. E. Witherington, and P. L. Lutz. 1997. Human impacts on sea turtle survival. Pages 387-409 in P. L. L. J. A. Musick, editor. *The Biology of Sea Turtles*. CRC Press, New York, New York.
- Lyrholm, T., and U. Gyllensten. 1998. Global matrilineal population structure in sperm whales as indicated by mitochondrial DNA sequences. *Proceedings of the Royal Society of London Series B Biological Sciences* 265(1406):1679-1684.
- Lysiak, N. S. J., S. J. Trumble, A. R. Knowlton, and M. J. Moore. 2018. Characterizing the Duration and Severity of Fishing Gear Entanglement on a North Atlantic Right Whale (*Eubalaena glacialis*) Using Stable Isotopes, Steroid and Thyroid Hormones in Baleen. *Frontiers in Marine Science* 5.
- MacLeod, C. D. 2009. Global climate change, range changes and potential implications for the conservation of marine cetaceans: A review and synthesis. *Endangered Species Research* 7(2):125-136.
- Madsen, P. T., and coauthors. 2006a. Quantitative measures of air-gun pulses recorded on sperm whales (*Physeter macrocephalus*) using acoustic tags during controlled exposure experiments. *Journal of the Acoustical Society of America* 120(4):2366-2379.
- Madsen, P. T., M. Wahlberg, J. Tougaard, K. Lucke, and P. Tyack. 2006b. Wind turbine underwater noise and marine mammals: implications of current knowledge and data needs. *Marine Ecology Progress Series* 309:279-295.
- Magalhaes, S., and coauthors. 2002. Short-term reactions of sperm whales (*Physeter macrocephalus*) to whale-watching vessels in the Azores. *Aquatic Mammals* 28(3):267-274.
- Mallette S. and Barco, S. 2017. Aerial Survey Baseline Monitoring in the Continental Shelf Region of the VACAPES OPAREA: January - February 2017. Data downloaded from OBIS-SEAMAP (<https://seamap.env.duke.edu/dataset/2212>).
- Mallette, S. D., and coauthors. 2016. Offshore Energy Planning: Documenting Megafauna off Virginia's Coast Using Aerial Surveys. VAQF Scientific Report. 2016-04. Data downloaded from OBIS-SEAMAP (<http://seamap.env.duke.edu/dataset/1373>) on 2023-08-16.
- Mann, J., R. C. Connor, L. M. Barre, and M. R. Heithaus. 2000. Female reproductive success in wild bottlenose dolphins (*Tursiops* sp.): Life history, habitat, provisioning, and group size effects. *Behavioral Ecology* 11:210-219.
- Mansfield, K. L. 2006. Sources of mortality, movements, and behavior of sea turtles in Virginia. College of William and Mary.
- Marmo, B., I. Roberts, M. P. Buckingham, S. King, and C. Booth. 2013. Modelling of noise effects of operational offshore wind turbines including noise transmission through various foundation types.
- Masuda, A. 2010. Natal Origin of Juvenile Loggerhead Turtles from Foraging Ground in Nicaragua and Panama Estimated Using Mitochondria DNA. California State University, Chico, California.
- Matthews, L., J. A. Mccordic, and S. E. Parks. 2014. Remote acoustic monitoring of North Atlantic right whales (*Eubalaena glacialis*) reveals seasonal and diel variations in acoustic behavior. *PLOS ONE* 9(3):e91367.
- Mavraki, N., I. De Mesel, S. Degraer, T. Moens, and J. Vanaverbeke. 2020. Resource niches of co-occurring invertebrate species at an offshore wind turbine indicate a substantial degree of trophic plasticity. *Frontiers in Marine Science* 7(June 2020).
- Mayo, C. A., and coauthors. 2018. Distribution, demography, and behavior of North Atlantic right whales (*Eubalaena glacialis*) in Cape Cod Bay, Massachusetts, 1998-2013. *Marine Mammal Science*.



- Mazaris, A. D., and coauthors. 2009. Assessing the relative importance of conservation measures applied on sea turtles: Comparison of measures focusing on nesting success and hatching recruitment success. *Amphibia-Reptilia* 30(2):221-231.
- Mazaris, A. D., G. Schofield, C. Gkazinou, V. Almpanidou, and G. C. Hays. 2017. Global sea turtle conservation successes. *Sci Adv* 3(9):e1600730.
- Maze-Foley, K., and K. D. Mullin. 2006. Cetaceans of the oceanic northern Gulf of Mexico: Distributions, group sizes and interspecific associations. *Journal of Cetacean Research and Management* 8(2):203-213.
- McCauley, R. D., and coauthors. 2017. Widely used marine seismic survey air gun operations negatively impact zooplankton. *Nature Ecology and Evolution* 1(7):195.
- Mccord, J. W., M. R. Collins, W. C. Post, and T. I. J. Smith. 2007. Attempts to develop an index of abundance for age-1 Atlantic sturgeon in South Carolina, USA. *American Fisheries Society Symposium* 56:397-403.
- McKenna, M. F., D. Ross, S. M. Wiggins, and J. A. Hildebrand. 2012. Underwater radiated noise from modern commercial ships. *Journal of the Acoustical Society of America* 131(2):92-103.
- McKenna, M. F., D. Ross, S. M. Wiggins, and J. A. Hildebrand. 2013. Relationship between container ship underwater noise levels and ship design, operational and oceanographic conditions. *Scientific Reports* 3:1760.
- McLellan, W. 2016a. UNCW Norfolk Canyon Aerial Survey - Left side - 2015. Data downloaded from OBIS-SEAMAP (<http://seamap.env.duke.edu/dataset/1354>) on 2023-08-16.
- McLellan, W. 2016b. UNCW Norfolk Canyon Aerial Survey - Right side - 2015. Data downloaded from OBIS-SEAMAP (<http://seamap.env.duke.edu/dataset/1356>) on 2023-08-16.
- McLellan, W. 2017. UNCW Norfolk Canyon Aerial Survey - Right side - 2016. Data downloaded from OBIS-SEAMAP (<http://seamap.env.duke.edu/dataset/1481>) on 2023-08-16.
- McLeod, B. A. 2008. Historic levels of genetic diversity in the North Atlantic right (Eubalaena glacialis) and bowhead whale (Balaena mysticetus). Trent University, Peterborough, Ontario, Canada.
- McLeod, B. A., and B. N. White. 2010. Tracking mtDNA heteroplasmy through multiple generations in the North Atlantic right whale (Eubalaena glacialis). *Journal of Heredity* 101(2):235-239.
- McMahon, C. R., and G. C. Hays. 2006. Thermal niche, large-scale movements and implications of climate change for a critically endangered marine vertebrate. *Global Change Biology* 12(7):1330-1338.
- McPherson, C., M. Wood, and R. Racca. 2016. Potential Impacts of Underwater Noise from Operation of the Barossa FPSO Facility on Marine Fauna. Document 01117, Version 1.0. JASCO Applied Sciences, Capalaba, Queensland.
- Mearns, A. J., and coauthors. 2017. Effects of Pollution on Marine Organisms. *Water Environ Res* 89(10):1704-1798.
- Meißner, K., H. Schabelon, J. Bellebaum, and H. Sordyl. 2006. Impacts of Submarine Cables on the Marine Environment - A Literature Review. Report by Institute of Applied Ecology (IfAO). Report for German Federal Agency for Nature Conservation (BfN).
- Melcon, M. L., and coauthors. 2012. Blue whales respond to anthropogenic noise. *PLoS ONE* 7(2):e32681.
- Mellinger, D. K., and coauthors. 2011. Confirmation of right whales near a nineteenth-century whaling ground east of southern Greenland. *Biology Letters* 7(3):411-413.
- Mendonca, M. T. 1981. Comparative growth rates of wild immature *Chelonia mydas* and *Caretta caretta* in Florida. *Journal of Herpetology* 15:447-451.
- Mesnick, S. L., and coauthors. 2011. Sperm whale population structure in the eastern and central North Pacific inferred by the use of single-nucleotide polymorphisms, microsatellites and mitochondrial DNA. *Molecular Ecology Resources* 11(Supplement 1):278-298.

- Methratta, E. T., and W. R. Dardick. 2019. Meta-analysis of finfish abundance at offshore wind farms. *Reviews in Fisheries Science and Aquaculture* 27(2):242-260.
- Meyer-Gutbrod, E., C. Greene, and K. Davies. 2018. Marine Species Range Shifts Necessitate Advanced Policy Planning: The Case of the North Atlantic Right Whale. *Oceanography* 31(2).
- Meyer-Gutbrod, E., C. Greene, K. Davies, and D. Johns. 2021. Ocean Regime Shift is Driving Collapse of the North Atlantic Right Whale Population. *Oceanography* 34(3):22-31.
- Meyer-Gutbrod, E. L., and C. H. Greene. 2014. Climate-associated regime shifts drive decadal-scale variability in recovery of North Atlantic right whale population. *Oceanography* 27(3):148-153.
- Michel, J., A. C. Bejarano, C. H. Peterson, and C. Voss. 2013. Review of biological and biophysical impacts from dredging and handling of offshore sand. OCS Study BOEM 2013-0119. U.S. Department of the Interior, Bureau of Ocean Energy Management, Herndon, Virginia.
- Miksis-Olds, J. L., and S. M. Nichols. 2016. Is low frequency ocean sound increasing globally? *The Journal of the Acoustical Society of America* 139(1):501-11.
- Miles, J., T. Martin, and L. Goddard. 2017. Current and wave effects around windfarm monopile foundations. *Coastal Engineering* 121:167-178.
- Miles, T., S. Murphy, J. Kohut, S. Borsetti, and D. Munroe. 2021. Offshore wind energy and the Mid-Atlantic Cold Pool: A review of potential interactions. *Marine Technology Society Journal* 55(4):72-87.
- Miller, L. M., and D. W. Keith. 2018. Climatic Impacts of Wind Power. *Joule* 2(12):2618-2632.
- Miller, M. H., and C. Klimovich. 2017. Endangered species act status review report: Giant manta ray (*Manta biostriis*), reef manta ray (*Manta alfredi*). National Marine Fisheries Service.
- Miller, P. J. O., M. P. Johnson, and P. L. Tyack. 2004. Sperm whale behaviour indicates the use of echolocation click buzzes 'creaks' in prey capture. *Proceedings of the Royal Society of London Series B Biological Sciences* 271(1554):2239-2247.
- Mintz, J., and R. Filadelfo. 2011. Exposure of marine mammals to broadband radiated noise. CNA Analysis & Solutions.
- Mitchell, S. M. J., M. J. Dadswell, C. Ceapa, and M. J. W. Stokesbury. 2020. Fecundity of Atlantic sturgeon (*Acipenser oxyrinchus* Mitchell, 1815) captured by the commercial fishery in the Saint John River, New Brunswick, Canada. *Journal of Applied Ichthyology* 36(2):142-150.
- Mitson, R. B., and H. P. Knudsen. 2003. Causes and effects of underwater noise on fish abundance estimation. *Aquatic Living Resources* 16(3):255-263.
- Mizroch, S. A., D. W. Rice, and J. M. Breiwick. 1984a. The fin whale, *Balaenoptera physalus*. *Marine Fisheries Review* 46(4):20-24.
- Mizroch, S. A., D. W. Rice, and J. M. Breiwick. 1984b. The sei whale, *Balaenoptera borealis*. *Marine Fisheries Review* 46(4):25-29.
- MMC. 2007. Marine mammals and noise: A sound approach to research and management. Marine Mammal Commission.
- MMS. 2007. Programmatic environmental impact statement for alternative energy development and production and alternate use of facilities on the outer continental shelf: Final environmental impact statement. Minerals Management Service.
- Moein, S., and coauthors. 1994. Evaluation of seismic sources for repelling sea turtles from hopper dredges. Final report submitted to the US Army Corps of Engineers Waterways Experiment Station. Virginia Institute of Marine Science (VIMS), College of William and Mary, Gloucester Point, Virginia.
- Mohler, J. W. 2003. Culture Manual for the Atlantic sturgeon. United States Fish and Wildlife Service, Hadley, Massachusetts.
- Molfetti, É., and coauthors. 2013. Recent Demographic History and Present Fine-Scale Structure in the Northwest Atlantic Leatherback (*Dermodochelys coriacea*) Turtle Population. *PLOS ONE* 8(3):e58061.

- Monsarrat, S., and coauthors. 2016. A spatially explicit estimate of the pre-whaling abundance of the endangered North Atlantic right whale. *Conservation Biology*.
- Moore, M. J., and coauthors. 2021. REVIEW: Assessing North Atlantic right whale health: threats, and development of tools critical for conservation of the species. *Disease of Aquatic Organisms* 143:205-226.
- Moore, S. E., and R. P. Angliss. 2006. Overview of planned seismic surveys offshore northern Alaska, July-October 2006. Paper SC/58/E6 presented to IWC Scientific Committee, St Kitts and Nevis.
- Morano, J. L., and coauthors. 2012. Acoustically detected year-round presence of right whales in an urbanized migration corridor. *Conservation Biology* 26(4):698-707.
- Morreale, S. J., and E. A. Standora. 2005. Western North Atlantic waters: Crucial developmental habitat for Kemp's ridley and loggerhead sea turtles. *Chelonian Conservation and Biology* 4(4):872-882.
- Moser, M. L., and S. W. Ross. 1995. Habitat use and movements of shortnose and Atlantic sturgeons in the lower Cape Fear River, North Carolina. *Transactions of the American Fisheries Society* 124(2):225.
- MSPO. 1993. Kennebec River Resource Management Plan. Maine State Planning Office.
- Mullin, K. D., and G. L. Fulling. 2004. Abundance of cetaceans in the oceanic northern Gulf of Mexico, 1996-2001. *Marine Mammal Science* 20(4):787-807.
- Mullin, K. D., and W. Hoggard. 2000. Visual surveys of cetaceans and sea turtles from aircraft and ships. Minerals Management Service.
- Mullin, K. D., W. Hoggard, and L. J. Hansen. 2004. Abundance and seasonal occurrence of cetaceans in outer continental shelf and slope waters of the north-central and northwestern Gulf of Mexico. *Gulf of Mexico Science* 22(1):62-73.
- Mullin, K. D., and coauthors. 1994. Cetaceans on the upper continental slope in the north-central Gulf of Mexico. *Fishery Bulletin* 92(4):773-786.
- Munroe, D. M., and coauthors. 2016. Fishing and bottom water temperature as drivers of change in maximum shell length in Atlantic surfclams (*Spisula solidissima*). *Estuarine, Coastal and Shelf Science* 170:112-122.
- Murawski, S. A., and A. L. Pacheco. 1977. Biological and fisheries data on Atlantic sturgeon, *Acipenser oxyrinchus* (Mitchill). Sandy Hook Laboratory, Northeast Fisheries Center, National Marine Fisheries Service, National Oceanic and Atmospheric Administration, US Department of Commerce.
- Murphy, T. M. 1989. Sea turtle & shrimp fishing interactions: a summary and critique of relevant information. Center for Marine Conservation.
- Murray, K. T. 2015. Estimated loggerhead (*Caretta caretta*) interactions in the Mid-Atlantic scallop dredge fishery, 2009-2014. National Oceanic and Atmospheric Administration, Northeast Fisheries Science Center, Woods Hole, Massachusetts.
- Murray, K. T. 2018. Estimated Bycatch of Sea Turtles in Sink Gillnet Gear. NOAA Technical Memorandum NMFS-NE-242. National Marine Fisheries Service, Northeast Fisheries Science Center, Woods Hole, Massachusetts.
- Murray, K. T. 2020. Estimated Magnitude of Sea Turtle Interactions and Mortality in US Bottom Trawl Gear, 2014-2018. NOAA Technical Memorandum NMFS-NE-260. National Marine Fisheries Service, Northeast Fisheries Science Center, Woods Hole, Massachusetts.
- Muto, M. M., and coauthors. 2019. Alaska Marine Mammal Stock Assessments, 2018. U.S. Department of Commerce.
- Nadeem, K., J. E. Moore, Y. Zhang, and H. Chipman. 2016. Integrating population dynamics models and distance sampling data: A spatial hierarchical state-space approach. *Ecology* 97(7):1735-1745.

- Nagel, T., J. Chauchat, A. Wirth, and C. Bonamy. 2018. On the multi-scale interactions between an offshore-wind-turbine wake and the ocean-sediment dynamics in an idealized framework – A numerical investigation. *Renewable Energy* 115:783-796.
- NALWG. 2018. Northwest Atlantic Leatherback Turtle Status Assessment. Northwest Atlantic Leatherback Working Group.
- NALWG. 2019. *Dermochelys coriacea* (Northwest Atlantic Ocean subpopulation) (errata version published in 2020). Northwest Atlantic Leatherback Working Group. The IUCN Red List of Threatened Species 2019: e.T46967827A184748440.
- Narazaki, T., K. Sato, K. J. Abernathy, G. J. Marshall, and N. Miyazaki. 2013. Loggerhead Turtles (*Caretta caretta*) Use Vision to Forage on Gelatinous Prey in Mid-Water. *PLOS ONE* 8(6):e66043.
- Narváez, D., and coauthors. 2015. Long-Term Dynamics In Atlantic Surfclam (*Spisula solidissima*) Populations: The Role of Bottom Water Temperature. *Journal of Marine Systems* 141:136-148.
- NAS. 2017. Approaches to Understanding the Cumulative Effects of Stressors on Marine Mammals. National Academies of Sciences, Engineering, and Medicine. The National Academies Press, Washington, District of Columbia.
- NDBC. 2023. Station CHYV2 - 8638999 - Cape Henry, VA. National Data Buoy Center. National Oceanic and Atmospheric Administration, National Weather Service, National Data Buoy Center, Mississippi.
- Nedwell, J., and D. Howell. 2004. A review of offshore windfarm related underwater noise sources. Collaborative Offshore Wind Energy Research Into the Environment (COWRIE).
- Nedwell, J., J. Langworthy, and D. Howell. 2003. Assessment of sub-sea acoustic noise and vibration from offshore wind turbines and its impact on marine wildlife; initial measurements of underwater noise during construction of offshore windfarms, and comparison with background noise, 544 R 0424, Southampton, U.K.
- Nelms, S. E., W. E. Piniak, C. R. Weir, and B. J. Godley. 2016. Seismic surveys and marine turtles: An underestimated global threat? *Biological Conservation* 193:49-65.
- Nichols, T. A., T. W. Anderson, and A. Širović. 2015. Intermittent Noise Induces Physiological Stress in a Coastal Marine Fish. *PLOS ONE* 10(9):e0139157.
- Nieukirk, S. L., K. M. Stafford, D. K. Mellinger, R. P. Dziak, and C. G. Fox. 2004. Low-frequency whale and seismic airgun sounds recorded in the mid-Atlantic Ocean. *Journal of the Acoustical Society of America* 115(4):1832-1843.
- Niklitschek, E. J., and D. H. Secor. 2005. Modeling spatial and temporal variation of suitable nursery habitats for Atlantic sturgeon in the Chesapeake Bay. *Estuarine, Coastal and Shelf Science* 64(1):135-148.
- NMFS. 1998. Status review of Atlantic sturgeon (*Acipenser oxyrinchus oxyrinchus*). National Oceanic and Atmospheric Administration, National Marine Fisheries Service.
- NMFS. 2001. Stock assessments of loggerhead and leatherback sea turtles and an assessment of the impact of the pelagic longline fishery on the loggerhead and leatherback sea turtles of the western North Atlantic. National Oceanic and Atmospheric Administration, National Marine Fisheries Service, Southeast Fisheries Science Center.
- NMFS. 2005. Recovery plan for the North Atlantic right whale (*Eubalaena glacialis*). National Oceanic and Atmospheric Administration, National Marine Fisheries Service.
- NMFS. 2007. Status review of Atlantic sturgeon (*Acipenser oxyrinchus oxyrinchus*). Atlantic Sturgeon Status Review Team. National Marine Fisheries Service, National Oceanic and Atmospheric Administration.
- NMFS. 2009a. An assessment of loggerhead sea turtles to estimate impacts of mortality reductions on population dynamics. National Oceanic and Atmospheric Administration, National Marine Fisheries Service.

- NMFS. 2009b. An assessment of loggerhead sea turtles to estimate impacts of mortality reductions on population dynamics. National Marine Fisheries Service, Southeast Fisheries Science Center.
- NMFS. 2010a. Final recovery plan for the fin whale (*Balaenoptera physalus*). National Oceanic and Atmospheric Administration, National Marine Fisheries Service, Silver Spring, Maryland.
- NMFS. 2010b. Final recovery plan for the sperm whale (*Physeter macrocephalus*). National Oceanic and Atmospheric Administration, National Marine Fisheries Service, Office of Protected Resources, Silver Spring, Maryland.
- NMFS. 2010c. Recovery plan for the fin whale (*Balaenoptera physalus*). U.S. Department of Commerce, National Oceanic and Atmospheric Administration, National Marine Fisheries Service, Office of Protected Resources, Silver Spring, Maryland.
- NMFS. 2010d. Recovery plan for the sperm whale (*Physeter macrocephalus*). National Oceanic and Atmospheric Administration, National Marine Fisheries Service, Silver Spring, Maryland.
- NMFS. 2011a. Preliminary summer 2010 regional abundance estimate of loggerhead turtles (*Caretta caretta*) in northwestern Atlantic Ocean continental shelf waters. National Oceanic and Atmospheric Administration, National Marine Fisheries Service, Southeast Fisheries Science Center and Northeast Fisheries Science Center.
- NMFS. 2011b. Recovery plan for the sei whale (*Balaenoptera borealis*). National Marine Fisheries Service, Office of Protected Resources.
- NMFS. 2013. Endangered Species Act Section 7 Consultation on the Continued Implementation of Management Measures for the Northeast Multispecies, Monkfish, Spiny Dogfish, Atlantic Bluefish, Northeast Skate Complex, Mackerel/Squid/Butterfish, and Summer Flounder/Scup/Black Sea Bass Fisheries. O. National Marine Fisheries Service. Greater Atlantic Regional Fisheries, editor. National Marine Fisheries Service, Northeast Regional Office, Protected Resources Division.
- NMFS. 2014. Endangered Species Act Section 7 Consultation on the Continued Implementation of Management Measures for the American Lobster Fishery [Consultation No. NER-2014-11076]. GARFO-2014-00013. National Marine Fisheries Service, Greater Atlantic Regional Fisheries Office, through its Sustainable Fisheries Division.
- NMFS. 2015a. National Marine Fisheries Service Endangered Species Act Section 7 Consultation Biological Opinion Deepwater Wind: Block Island Wind Farm and Transmission System. NER-2015-12248 GARFO-2015-00031. National Marine Fisheries Service, Greater Atlantic Regional Fisheries Office.
- NMFS. 2015b. Reinitiation of Endangered Species Act (ESA) Section 7 Consultation on the Continued Authorization of the Fishery Management Plan (FMP) for Coastal Migratory Pelagic (CMP) Resources in the Atlantic and Gulf of Mexico under the Magnuson-Stevens Fishery Management and Conservation Act (MSFMCA). Consultation No. SER-20 15-15985. National Oceanic and Atmospheric Administration (NOAA), National Marine Fisheries Service (NMFS), Southeast Regional Office (SERO).
- NMFS. 2015c. Sperm whale (*Physeter macrocephalus*) 5-year review: Summary and evaluation. National Marine Fisheries Service, Office of Protected Resources.
- NMFS. 2016a. Endangered Species Act (ESA) Section 7 Consultation on the Continued Authorization of Snapper-Grouper Fishing in the U.S. South Atlantic Exclusive Economic Zone (EEZ) as Managed under the Snapper-Grouper Fishery Management Plan (SGFMP) of the South Atlantic Region, including Proposed Regulatory Amendment 16 to the SGFMP (SER-2016-17768). National Marine Fisheries Service (NMFS), Southeast Regional Office (SERO), Sustainable Fisheries Division (F/SER2).
- NMFS. 2016b. Fin whale (*Balaenoptera physalus physalus*): California/Oregon/Washington stock. Stock Assessment Report.

- NMFS. 2016c. National Marine Fisheries Service Endangered Species Act Section 7 Consultation Biological Opinion Virginia Offshore Wind Technology Advancement Project. NER-2015-12128 GARFO-2015-00030. National Marine Fisheries Service, Greater Atlantic Regional Fisheries Office.
- NMFS. 2017a. Designation of Critical Habitat for the Gulf of Maine, New York Bight, and Chesapeake Bay Distinct Population Segments of Atlantic Sturgeon : ESA Section 4(b)(2) Impact Analysis and Biological Source Document with the Economic Analysis and Final Regulatory Flexibility Analysis Finalized June 3, 2017.244.
- NMFS. 2017b. North Atlantic Right Whale (*Eubalaena glacialis*) 5-Year Review: Summary and Evaluation. Greater Atlantic Regional Fisheries Office, National Marine Fisheries Service, National Oceanic and Atmospheric Administration, U.S. Department of Commerce, Gloucester, Massachusetts.
- NMFS. 2018a. Biological and Conference Opinion on U.S. Navy Atlantic Fleet Training and Testing and the National Marine Fisheries Service's Promulgation of Regulations Pursuant to the Marine Mammal Protection Act for the Navy to "Take" Marine Mammals Incidental to Atlantic Fleet Training and Testing. FPR-2018-9259.
- NMFS. 2018b. Oceanic whitetip shark recovery outline. Pages 7 *in*. National Marine Fisheries Service, Office of Protected Resources, [https://media.fisheries.noaa.gov/dam-migration/final\\_oceanic\\_whitetip\\_recovery\\_outline.pdf](https://media.fisheries.noaa.gov/dam-migration/final_oceanic_whitetip_recovery_outline.pdf).
- NMFS. 2018c. Recovery Outline for the Atlantic Sturgeon Distinct Population Segments. NOAA Fisheries Office of Protected Resources.
- NMFS. 2019a. Amended Incidental Take Statement for the Biological and Conference Opinion on Navy Atlantic Fleet Training and Testing Activities. FPR-2018-9259.
- NMFS. 2019b. Fin Whale (*Balaenoptera physalus*) 5-Year Review: Summary and Evaluation. National Marine Fisheries Service, Office of Protected Resources, Silver Spring, MD.
- NMFS. 2019c. Giant manta ray recovery outline. NOAA Fisheries Office of Protected Resources, <https://www.fisheries.noaa.gov/resource/document/giant-manta-ray-recovery-outline>.
- NMFS. 2020a. Endangered Species Act - Section 7 Consultation Biological Opinion Nexan Plant dredging, rip-rap installation, and wharf construction, Goose Creek, Berkeley County, South Carolina, Ref. SAC-2019-00767, Brian Boan, Dredging, Rip-rap Installation, and Wharf Construction, Goose Creek, Berkeley County, South Carolina. National Marine Fisheries Service, Southeast Region.
- NMFS. 2020b. Endangered Species Act (ESA) Section 7 Consultation on the Operation of the HMS Fisheries (Excluding Pelagic Longline) under the Consolidated Atlantic HMS Fishery Management Plan (F/SER/2015/16974). National Marine Fisheries Service (NMFS), Southeast Regional Office (SERO), Protected Resources Division.
- NMFS. 2020c. Endangered Species Act (ESA) Section 7 Consultation on the Pelagic Longline Fishery for Atlantic Highly Migratory Species (F/SER/2014/00006[13697]). National Marine Fisheries Service (NMFS), Southeast Regional Office (SERO), Protected Resources Division.
- NMFS. 2020d. Scalloped Hammerhead Shark (*Sphyrna lewini*) 5-Year Review: Summary and Evaluation. National Marine Fisheries Service Office of Protected Resources, Silver Spring, MD.
- NMFS. 2021a. Construction, Operation, Maintenance, and Decommissioning of the South Fork Offshore Energy Project (Lease OCS-A 0517). GARFO-2021-00353. National Marine Fisheries Service, Greater Atlantic Regional Fisheries Office.
- NMFS. 2021b. Endangered Species Act (ESA) - Section 7 Consultation Biological Opinion Reinitiation of Endangered Species Act (ESA) Section 7 Consultation on the Implementation of the Sea Turtle Conservation Regulations under the ESA and the Authorization of the Southeast U.S. Shrimp Fisheries in Federal Waters under the Magnuson-Stevens Fishery Management and Conservation Act

- (MSFMCA). SERO-2021-00087. National Oceanic and Atmospheric Administration (NOAA), National Marine Fisheries Service (NMFS), Southeast Regional Office (SERO), St. Petersburg, Florida.
- NMFS. 2021c. Endangered Species Act Section 7 Consultation on the Atlantic Sea Scallop Fishery Management Plan [ECO ID: GARFO-2020-00437]. National Marine Fisheries Service, Greater Atlantic Regional Fisheries Office, through its Protected Resources Division.
- NMFS. 2021d. Endangered Species Act Section 7 Consultation on the: (a) Authorization of the American Lobster, Atlantic Bluefish, Atlantic Deep-Sea Red Crab, Mackerel/Squid/Butterfish, Monkfish, Northeast Multispecies, Northeast Skate Complex, Spiny Dogfish, Summer Flounder/Scup/Black Sea Bass, and Jonah Crab Fisheries and (b) Implementation of the New England Fishery Management Council's Omnibus Essential Fish Habitat Amendment 2. [Consultation No. GARFO-2017-00031]. National Marine Fisheries Service, Greater Atlantic Regional Fisheries Office, Protected Resources Division.
- NMFS. 2021e. National Marine Fisheries Service Endangered Species Act Section 7 Biological Opinion Construction, Operation, Maintenance, and Decommissioning of the Vineyard Wind 1 Offshore Wind Energy Project (Lease OCS-A 0501) - Reinitiation. GARFO-2019-00343. National Marine Fisheries Service, Greater Atlantic Regional Fisheries Office.
- NMFS. 2021f. Offshore Wind Site Assessment and Site Characterization Activities Programmatic Consultation, Programmatic ESA Section 7 Consultation. National Marine Fisheries Service, Greater Atlantic Regional Fisheries Office.
- NMFS. 2021g. Sei Whale (*Balaenoptera borealis*) 5-Year Review: Summary and Evaluation. National Marine Fisheries Service, Office of Protected Resources, Silver Spring, MD.
- NMFS. 2022a. Chesapeake Bay Distinct Population Segment of Atlantic Sturgeon (*Acipenser oxyrinchus oxyrinchus*) 5-Year Review: Summary and Evaluation. National Marine Fisheries Service. Greater Atlantic Regional Fisheries Office  
Gloucester, Massachusetts.
- NMFS. 2022b. Gulf of Maine Distinct Population Segment of Atlantic Sturgeon (*Acipenser oxyrinchus oxyrinchus*) 5-Year Review: Summary and Evaluation. National Marine Fisheries Service Greater Atlantic Regional Fisheries Office, Gloucester, Massachusetts.
- NMFS. 2022c. New York Bight Distinct Population Segment of Atlantic Sturgeon (*Acipenser oxyrinchus oxyrinchus*) 5-Year Review: Summary and Evaluation. National Marine Fisheries Service Greater Atlantic Regional Fisheries Office, Gloucester, Massachusetts.
- NMFS. 2022d. North Atlantic right whale (*Eubalaena glacialis*) 5-year review: Summary and evaluation. National Marine Fisheries Service Greater Atlantic Regional Office, Gloucester, MA.
- NMFS. 2022e. Recovering Threatened and Endangered Species, FY 2019–2020 Report to Congress. National Marine Fisheries Service, Silver Spring, MD.
- NMFS. 2023a. Construction, Operation, Maintenance, and Decommissioning of the Ocean Wind 1 Offshore Energy Project (Lease OCS-A 0498) GARFO-2022-02397. National Marine Fisheries Service, Greater Atlantic Regional Fisheries Office.
- NMFS. 2023b. National Marine Fisheries Service Endangered Species Act Section 7 Consultation Biological Opinion Construction, Operation, Maintenance, and Decommissioning of the Empire Wind Offshore Energy Project (Lease OCS-A 0512) and the Connected Action at South Brooklyn Marine Terminal. GARFO-2023-00454. National Marine Fisheries Service Greater Atlantic Regional Fisheries Office.
- NMFS. 2023c. National Marine Fisheries Service Endangered Species Act Section 7 Consultation Biological Opinion Construction, Operation, Maintenance, and Decommissioning of the Revolution Wind Offshore Energy Project (Lease OCS-A 0486). GARFO-2022-03532. National Marine Fisheries Service, Greater Atlantic Regional Fisheries Office.

- NMFS, and USFWS. 1992. Recovery plan for leatherback turtles in the U.S. Caribbean, Atlantic, and Gulf of Mexico (*Dermochelys coriacea*), Washington, D.C.
- NMFS, and USFWS. 1993. Recovery plan for hawksbill turtles in the U.S. Caribbean Sea, Atlantic Ocean, and Gulf of Mexico (*Eretmochelys imbricata*).
- NMFS, and USFWS. 1998. Recovery plan for U.S. Pacific populations of the leatherback turtle (*Dermochelys coriacea*), Portland, Oregon.
- NMFS, and USFWS. 2008. Recovery plan for the northwest Atlantic population of the loggerhead sea turtle (*Caretta caretta*), second revision. National Oceanic and Atmospheric Administration, National Marine Fisheries Service, Office of Protected Resources, Silver Spring, Maryland.
- NMFS, and USFWS. 2013a. Hawksbill sea turtle (*Eretmochelys imbricata*) 5-year review: Summary and evaluation National Marine Fisheries Service and U.S. Fish and Wildlife Service, Silver Spring, Maryland.
- NMFS, and USFWS. 2013b. Leatherback Sea Turtle (*Dermochelys Coriacea*) 5-Year Review : Summary and Evaluation. NOAA, National Marine Fisheries Service, Office of Protected Resources and U.S. Fish and Wildlife Service, Southeast Region Jacksonville Ecological Services Office.
- NMFS, and USFWS. 2015a. Kemp's Ridley Sea Turtle (*Lepidochelys kempii*) 5-year Review: Summary and Evaluation. National Marine Fisheries Service and United States Fish and Wildlife Service, Silver Spring, Maryland.
- NMFS, and USFWS. 2015b. Kemp's ridley sea turtle (*Lepidochelys kempii*) 5-year review: Summary and evaluation. National Marine Fisheries Service, Office of Protected Resources and U.S. Fish and Wildlife Service, Southwest Region.
- NMFS, and USFWS. 2019. Recovery Plan for the Gulf of Maine Distinct Population Segment of Atlantic Salmon (*Salmo salar*). National Oceanic and Atmospheric Administration National Marine Fisheries Service, Fish and Wildlife Service Ecological Services and Fisheries.
- NMFS, and USFWS. 2020. Endangered Species Act status review of the leatherback turtle (*Dermochelys coriacea*) 2020, National Marine Fisheries Service Office of Protected Resources and U.S. Fish and Wildlife Service.
- NMFS, USFWS, and SEMARNAT. 2011. Bi-national recovery plan for the Kemp's ridley turtle (*Lepidochelys kempii*).
- NMFS, U. 1991. Recovery plan for U.S. population of Atlantic green turtle. U.S. Fish and Wildlife Service and National Marine Fisheries Service.
- NOAA. 2014. 2014 report on the entanglement of marine species in marine debris with an emphasis on species in the United States. National Oceanic and Atmospheric Administration, Marine Debris Program, Silver Spring, Maryland.
- NOAA. 2018. Revisions to: Technical Guidance for Assessing the Effects of Anthropogenic Sound on Marine Mammal Hearing (Version 2.0): Underwater Thresholds for Onset of Permanent and Temporary Threshold Shifts. Office of Protected Resources, National Marine Fisheries Service, National Oceanic and Atmospheric Administration, U.S. Department of Commerce, Silver Spring, Maryland.
- Normandeau. 2015. Modeling Sediment Dispersion from Cable Burial for the Seacoast Reliability Project, Little Bay, New Hampshire. Normandeau Associates Inc.
- Normandeau, Exponent, T. T., and A. Gill. 2011. Effects of EMFs from undersea powercables on elasmobranchs and other marine species. U.S. Department of the Interior, Bureau of Ocean Energy Management, Regulation, and Enforcement, Pacific OCS Region, Camarillo, California.
- Norton, S. L., and coauthors. 2012. Designating critical habitat for juvenile endangered smalltooth sawfish in the United States. *Marine and Coastal Fisheries* 4(1):473-480.



- Novak, A. J., A. E. Carlson, C. R. Wheeler, G. S. Wippelhauser, and J. A. Sulikowski. 2017. Critical Foraging Habitat of Atlantic Sturgeon Based on Feeding Habits, Prey Distribution, and Movement Patterns in the Saco River Estuary, Maine. *Transactions of the American Fisheries Society* 146(2):308-317.
- Nowacek, D. P., L. H. Thorne, D. W. Johnston, and P. L. Tyack. 2007. Responses of cetaceans to anthropogenic noise. *Mammal Review* 37(2):81-115.
- Nowacek, S. M., R. S. Wells, and A. R. Solow. 2001. Short-term effects of boat traffic on bottlenose dolphins, *Tursiops truncatus*, in Sarasota Bay, Florida. *Marine Mammal Science* 17(4):673-688.
- NRC. 1990. Sea turtle mortality associated with human activities. Pages 74-117 in N. R. Council, editor. *Decline of the Sea Turtles: Causes and Prevention*. National Academy Press, National Research Council Committee on Sea Turtle Conservation, Washington, D. C.
- NRC. 2003. *Ocean Noise and Marine Mammals*. National Academies Press.
- O'herm, J. E., and D. C. Biggs. 2009. Sperm whale (*Physeter macrocephalus*) habitat in the Gulf of Mexico: Satellite observed ocean color and altimetry applied to small-scale variability in distribution. *Aquatic Mammals* 35(3):358-366.
- O'Leary, S. J., K. J. Dunton, T. L. King, M. G. Frisk, and D. D. Chapman. 2014. Genetic diversity and effective size of Atlantic sturgeon, *Acipenser oxyrinchus oxyrinchus* river spawning populations estimated from the microsatellite genotypes of marine-captured juveniles. *Conservation Genetics* 15(5):1173-1181.
- O'Brien, O., and coauthors. 2022. Repatriation of a historical North Atlantic right whale habitat during an era of rapid climate change. *Scientific Reports* 12(1):1-10.
- Oakley, N. C. 2003. Status of shortnose sturgeon, *Acipenser brevirostrum*, in the Neuse River, North Carolina. North Carolina State University, Raleigh, North Carolina.
- Ocean Surveys. 2005. Thirty Month Post-Installation Benthic Monitoring Survey for the Cross Sound Cable Project. Prepared for Cross-Sound Cable Company, LLC. . Prepared by Ocean Surveys, Inc., for Cross-Sound Cable Company, LLC.
- Ohsumi, S., and S. Wada. 1974. Status of whale stocks in the North Pacific, 1972. Report of the International Whaling Commission 24:114-126.
- Oliver, M. J., and coauthors. 2013. Shrinking the Haystack: Using an AUV in an Integrated Ocean Observatory to Map Atlantic Sturgeon in the Coastal Ocean. *Fisheries* 38(5):210-216.
- Ong, T. L., J. Stabile, I. Wirgin, and J. R. Waldman. 1996. Genetic divergence between *Acipenser oxyrinchus oxyrinchus* and *A. o. desotoi* as assessed by mitochondrial DNA sequencing analysis. *Copeia* (2):6.
- OSPAR. 2009. Assessment of the environmental impact of underwater noise. OSPAR Commission.
- Pace, R. I., and R. Merrick. 2008. Northwest Atlantic Ocean Habitats Important to the Conservation of North Atlantic Right Whales (*Eubalaena glacialis*). NEFSC Ref. Doc. 08-07.
- Pace, R. M., P. J. Corkeron, and S. D. Kraus. 2017. State-space mark-recapture estimates reveal a recent decline in abundance of North Atlantic right whales. *Ecology and Evolution* 7:8730–8741.
- Pace, R. M., R. Williams, S. D. Kraus, A. R. Knowlton, and H. M. Pettis. 2021. Cryptic mortality of North Atlantic right whales. *Conservation Science and Practice*.
- Paladino, F. V., M. P. O'connor, and J. R. Spotila. 1990. Metabolism of leatherback turtles, gigantothermy, and thermoregulation of dinosaurs. *Nature* 344:858-860.
- Palka, D., and M. Johnson. 2007. Cooperative research to study dive patterns of sperm whales in the Atlantic Ocean. U.S. Department of the Interior, Minerals Management Service, Gulf of Mexico OCS Region.
- Palka, D. L., and coauthors. 2017. Atlantic marine assessment program for protected species: 2010-2014. US Dept. of the Interior, Bureau of Ocean Energy Management.
- Papastamatiou, Y. P., and coauthors. 2018. Optimal swimming strategies and behavioral plasticity of oceanic whitetip sharks. *Scientific Reports* 8(1):551.

- Parker, L. G. 1995. Encounter with a juvenile hawksbill turtle offshore Sapelo Island, Georgia. *Marine Turtle Newsletter*:19-22.
- Parks, S. E., C. W. Clark, and P. L. Tyack. 2007a. Short- and long-term changes in right whale calling behavior: The potential effects of noise on acoustic communication. *Journal of the Acoustical Society of America* 122(6):3725-3731.
- Parks, S. E., M. Johnson, D. Nowacek, and P. L. Tyack. 2011. Individual right whales call louder in increased environmental noise. *Biology Letters* 7(1):33-35.
- Parks, S. E., D. R. Ketten, J. T. O'malley, and J. Arruda. 2007b. Anatomical predictions of hearing in the North Atlantic right whale. *Anatomical Record: Advances in Integrative Anatomy and Evolutionary Biology* 290(6):734-744.
- Parks, S. E., I. Urazghildiiev, and C. W. Clark. 2009. Variability in ambient noise levels and call parameters of North Atlantic right whales in three habitat areas. *Journal of the Acoustical Society of America* 125(2):1230-1239.
- Patrício, A. R., L. A. Hawkes, J. R. Monsinjon, B. J. Godley, and M. Fuentes. 2021. Climate change and marine turtles: recent advances and future directions. *Endangered Species Research* 44:363-395.
- Payne, P. M., J. R. Nicolas, L. O'brien, and K. D. Powers. 1986. The distribution of the humpback whale, *Megaptera novaeangliae*, on Georges Bank and in the Gulf of Maine in relation to densities of the sand eel, *Ammodytes americanus*. *Fishery Bulletin* 84(2):271-277.
- Payne, P. M., and coauthors. 1990. Recent fluctuations in the abundance of baleen whales in the southern Gulf of Maine in relation to changes in prey abundance. *Fishery Bulletin* 88(4):687-696.
- Peckham, S. H., and coauthors. 2008. High mortality of loggerhead turtles due to bycatch, human consumption and strandings at Baja California Sur, Mexico, 2003 to 2007. *Endangered Species Research* 5(2-3):171-183.
- Pecl, G. T., and G. D. Jackson. 2008. The potential impacts of climate change on inshore squid: Biology, ecology and fisheries. *Reviews in Fish Biology and Fisheries* 18:373-385.
- Pendleton, D. E., and coauthors. 2022. Decadal-scale phenology and seasonal climate drivers of migratory baleen whales in a rapidly warming marine ecosystem. *Global Change Biology* 28(16):4989-5005.
- Pendleton, R. M., and R. D. Adams. 2021. Long-Term Trends in Juvenile Atlantic Sturgeon Abundance May Signal Recovery in the Hudson River, New York, USA. *North American Journal of Fisheries Management* 41(4):1170-1181.
- Pershing, A. J., and coauthors. 2021. Climate impacts on the Gulf of Maine ecosystem. *Elementa: Science of the Anthropocene* 9(1).
- Pershing, A. J., and K. Stamieszkin. 2019. The North Atlantic Ecosystem, from Plankton to Whales. *Annual Review of Marine Science* 12:339–59.
- Pettis, H. M., and P. K. Hamilton. 2015. North Atlantic Right Whale Consortium 2015 Annual Report Card. North Atlantic Right Whale Consortium, <http://www.narwc.org/pdf/2015%20Report%20Card.pdf>.
- Pettis, H. M., and P. K. Hamilton. 2016. North Atlantic Right Whale Consortium 2016 Annual Report Card. North Atlantic Right Whale Consortium, <http://www.narwc.org/pdf/2016%20Report%20Card%20final.pdf>.
- Pettis, H. M., R. M. I. Pace, and P. K. Hamilton. 2022. North Atlantic Right Whale Consortium 2021 Annual Report Card. Report to the North Atlantic Right Whale Consortium. [https://www.narwc.org/uploads/1/1/6/6/116623219/2021report\\_cardfinal.pdf](https://www.narwc.org/uploads/1/1/6/6/116623219/2021report_cardfinal.pdf).
- Pettis, H. M., R. M. I. Pace, R. S. Schick, and P. K. Hamilton. 2017a. North Atlantic Right Whale Consortium 2017 Annual Report Card. North Atlantic Right Whale Consortium, [https://www.narwc.org/uploads/1/1/6/6/116623219/2017\\_report\\_cardamended.pdf](https://www.narwc.org/uploads/1/1/6/6/116623219/2017_report_cardamended.pdf).

- Pettis, H. M., I. R. M. Pace, and P. K. Hamilton. 2018. North Atlantic Right Whale Consortium 2018 Annual Report Card. Report to the North Atlantic Right Whale Consortium.  
[https://www.narwc.org/uploads/1/1/6/6/116623219/2018report\\_cardfinal.pdf](https://www.narwc.org/uploads/1/1/6/6/116623219/2018report_cardfinal.pdf).
- Pettis, H. M., I. R. M. Pace, and P. K. Hamilton. 2020. North Atlantic Right Whale Consortium 2019 annual report card. Report to the North Atlantic Right Whale Consortium.  
[https://www.narwc.org/uploads/1/1/6/6/116623219/2020narwcreport\\_cardfinal.pdf](https://www.narwc.org/uploads/1/1/6/6/116623219/2020narwcreport_cardfinal.pdf).
- Pettis, H. M., and coauthors. 2017b. Body condition changes arising from natural factors and fishing gear entanglements in North Atlantic right whales *Eubalaena glacialis*. *Endangered Species Research* 32:237-249.
- Pike, D. G., G. A. Vikingsson, T. Gunnlaugsson, and N. Oien. 2009. A note on the distribution and abundance of blue whales (*Balaenoptera musculus*) in the central and northeast North Atlantic. Pages 19-29 *in* C. L. D. Pike, editor. *North Atlantic Sightings Surveys: Counting Whales in the North Atlantic, 1987-2006*, volume NAMMCO Scientific Publications Volume 7.
- Pirotta, V., A. Grech, I. D. Jonsen, W. F. Laurance, and R. G. Harcourt. 2019. Consequences of global shipping traffic for marine giants. *Frontiers in Ecology and the Environment* 17(1):39-46.
- Platis, A., and coauthors. 2018. First in situ evidence of wakes in the far field behind offshore wind farms. *Scientific Reports* 8(1):2163.
- Plotkin, P. T. 1995. National Marine Fisheries Service and the U.S. Fish and Wildlife Service status reviews for sea turtles listed under the Endangered Species Act of 1973. National Oceanic and Atmospheric Administration, National Marine Fisheries Service, Silver Spring, Maryland.
- Plourde, S., C. Lehoux, C. L. Johnson, G. Perrin, and V. Lesage. 2019. North Atlantic right whale (*Eubalaena glacialis*) and its food: (I) a spatial climatology of *Calanus* biomass and potential foraging habitats in Canadian waters. *Journal of Plankton Research*.
- PMEL. 2020. Pacific Marine Environmental Laboratory, Carbon Program, OA Research. .  
<https://www.pmel.noaa.gov/co2/story/OA+Research>.
- Popper, A. N., and A. D. Hawkins. 2014. Assessing the impact of underwater sounds on fishes and other forms of marine life. *Acoustics Today* 10(2):30-41.
- Popper, A. N., and coauthors. 2014. Sound Exposure Guidelines. Pages 33-51 *in* ASA S3/SC1.4 TR-2014 Sound Exposure Guidelines for Fishes and Sea Turtles: A Technical Report prepared by ANSI-Accredited Standards Committee S3/SC1 and registered with ANSI. Springer International Publishing, Cham.
- Post, W. C., T. Darden, D. L. Peterson, M. Loeffler, and C. Collier. 2014. Research and management of endangered and threatened species in the southeast: riverine movements of shortnose and Atlantic sturgeon. Project NA10NMF4720036, Final Report. South Carolina Department of Natural Resources, Charleston.
- Price, E. R., and coauthors. 2004. Size, growth, and reproductive output of adult female leatherback turtles *Dermochelys coriacea*. *Endangered Species Research* 5:8-Jan.
- Purser, J., and A. N. Radford. 2011. Acoustic noise induces attention shifts and reduces foraging performance in three-spined sticklebacks (*Gasterosteus aculeatus*). *PLOS ONE* 6(2).
- Putman, N. F., K. L. Mansfield, R. He, D. J. Shaver, and P. Verley. 2013. Predicting the distribution of oceanic-stage Kemp's ridley sea turtles. *Biology Letters* 9(5):197-200.
- Putman, N. F., P. Verley, C. S. Endres, and K. J. Lohmann. 2015. Magnetic navigation behavior and the oceanic ecology of young loggerhead sea turtles. *Journal of Experimental Biology* 218(7):1044-1050.
- Pyzik, L., J. Caddick, and P. Marx. 2004. Chesapeake Bay: Introduction to an ecosystem. EPA 903-R-04-003, CBP/TRS 232/00.

- Quintana-Rizzo, E., and coauthors. 2021. Residency, demographics, and movement patterns of North Atlantic right whales *Eubalaena glacialis* in an offshore wind energy development area in southern New England, USA. *Endangered Species Research* 45:251-268.
- Rabalais, S. C., and N. N. Rabalais. 1980. The occurrence of sea turtles on the south Texas coast. *Contributions in Marine Science* 23:124-129.
- Radvan, S. 2019. Effects of inbreeding on fitness in the North Atlantic right whale (*Eubalaena glacialis*). Saint Mary's University, Halifax, Nova Scotia.
- Rastogi, T., and coauthors. 2004. Genetic analysis of 16th-century whale bones prompts a revision of the impact of Basque whaling on right and bowhead whales in the western North Atlantic. *Canadian Journal of Zoology* 82(10):1647-1654.
- Record, N., and coauthors. 2019. Rapid Climate-Driven Circulation Changes Threaten Conservation of Endangered North Atlantic Right Whales. *Oceanography* 32(2).
- Reed, J., L. New, P. Corkeron, and R. Harcourt. 2022. Multi-event modeling of true reproductive states of individual female right whales provides new insights into their decline. *Frontiers in Marine Science* 9.
- Reeves, R., A. J. Read, L. Lowry, S. K. Katona, and D. J. Boness. 2007. Report of the North Atlantic right whale program review. Marine Mammal Commission.
- Reeves, R. R., and H. Whitehead. 1997. Status of the sperm whale, *Physeter macrocephalus*, in Canada. *Canadian Field-Naturalist* 111(2):15.
- Reina, R. D., P. A. Mayor, J. R. Spotila, R. Piedra, and F. V. Paladino. 2002. Nesting ecology of the leatherback turtle, *Dermochelys coriacea*, at Parque Nacional Marino Las Baulas, Costa Rica: 1988–1989 to 1999–2000. *Copeia* 2002(3):653-664.
- Reine, K. J., and coauthors. 2014. Assessing impacts of navigation dredging on Atlantic sturgeon (*Acipenser oxyrinchus*). U.S. Army Engineer Research and Development Center, Environmental Laboratory, Vicksburg, MS.
- Rendell, L., S. L. Mesnick, M. L. Dalebout, J. Burtenshaw, and H. Whitehead. 2012. Can genetic differences explain vocal dialect variation in sperm whales, *Physeter macrocephalus*? *Behavior Genetics* 42(2):332-343.
- Rester, J., and R. Condrey. 1996. The occurrence of the hawksbill turtle, *Eretmochelys imbricata*, along the Louisiana coast. *Gulf of Mexico Science* 1996(2):112-114.
- Rice, A. N., and coauthors. 2014. Variation of ocean acoustic environments along the western North Atlantic coast: A case study in context of the right whale migration route. *Ecological Informatics* 21:89-99.
- Rice, D. W. 1989. Sperm whale, *Physeter macrocephalus* Linnaeus, 1758. Pages 177-233 in S. H. Ridgway, and R. Harrison, editors. *Handbook of Marine Mammals: Volume 4, River Dolphins and the Larger Toothed Whales*. Academic Press, London.
- Richardson, B., and S. D. 2016. Assessment of critical habitats for recovering the Chesapeake Bay Atlantic sturgeon distinct population segment. Final Report. Section 6 Species Recovery Grants Program Award Number: NA13NMF4720042.
- Richardson, W. J., C. R. Greene Jr., C. I. Malme, and D. H. Thomson. 1995. *Marine Mammals and Noise*. Academic Press, San Diego, California.
- Robbins, J., A. R. Knowlton, and S. Landry. 2015. Apparent survival of North Atlantic right whales after entanglement in fishing gear. *Biological Conservation* 191:421-427.
- Roberts, J. J., T. Yack, and P. N. Halpin. 2022. Habitat-based Marine Mammal Density Models for the U.S. Atlantic: Latest Versions (last updated 20 June 2022). Duke University Marine Geospatial Ecology Laboratory, <https://seamap.env.duke.edu/models/Duke/EC/>.
- Robinson, R. A., and coauthors. 2009. Travelling through a warming world: climate change and migratory species. *Endangered Species Research* 7:87-99.

- Rockwood, R. C., J. Calambokidis, and J. Jahncke. 2017. High mortality of blue, humpback and fin whales from modeling of vessel collisions on the U.S. West Coast suggests population impacts and insufficient protection. *PLOS ONE* 12(8):e0183052.
- Rodrigues, A. S. L., and coauthors. 2018. Forgotten Mediterranean calving grounds of grey and North Atlantic right whales: evidence from Roman archaeological records. *Proceedings of the Royal Society B: Biological Sciences* 285(1882).
- Rolland, R. M., and coauthors. 2017. Fecal glucocorticoids and anthropogenic injury and mortality in North Atlantic right whales *Eubalaena glacialis*. *Endangered Species Research* 34:417-429.
- Rolland, R. M., and coauthors. 2012. Evidence that ship noise increases stress in right whales. *Proceedings of the Royal Society of London Series B Biological Sciences* 279(1737):2363-2368.
- Rolland, R. M., and coauthors. 2016. Health of North Atlantic right whales *Eubalaena glacialis* over three decades: From individual health to demographic and population health trends. *Marine Ecology Progress Series* 542:265-282.
- Romero, A., I. A. Agudo, S. M. Green, and G. Notarbartolo Di Sciara. 2001. *Cetaceans of Venezuela: Their distribution and conservation status*. U.S. Department of Commerce, National Oceanic and Atmospheric Administration, National Marine Fisheries Service, Seattle, Washington.
- ROSA. 2021. *Offshore Wind Project Monitoring Framework and Guidelines March 2021*.
- Rosel, P. E., Wilcox, Lynsey A., Yamada, Tadasu K., Mullin, Keith D. 2021. A new species of baleen whale (*Balaenoptera*) from the Gulf of Mexico, with a review of its geographic distribution. *Marine Mammal Science*.
- Ross, C. H., and coauthors. 2021. Projecting regions of North Atlantic right whale, *Eubalaena glacialis*, habitat suitability in the Gulf of Maine for the year 2050. *Elementa: Science of the Anthropocene* 9(1).
- Ross, D. 1976. *Mechanics of Unterwater Noise*. Pergamon Press, New York.
- Ross, D. 1993. On ocean underwater ambient noise. *Acoustics Bulletin* 18:8-May.
- Ross, D. 2005. Ship Sources of Ambient Noise. *IEEE Journal of Oceanic Engineering* 30(2):257-261.
- Rothermel, E. R., and coauthors. 2020. Comparative migration ecology of striped bass and Atlantic sturgeon in the US Southern mid-Atlantic bight flyway. *PLOS ONE* 15(6):e0234442.
- Rudloe, A., and J. Rudloe. 2005. Site specificity and the impact of recreational fishing activity on subadult endangered Kemp's ridley sea turtles in estuarine foraging habitats in the northeastern Gulf of Mexico. *Gulf of Mexico Science* 23(2):186-191.
- Runkle, J., and coauthors. 2022. *Virginia State Climate Summary 2022*. NOAA Technical Report NESDIS 150-VA. NOAA/NESDIS, Silver Spring, MD.
- Salisbury, D. P., C. W. Clark, and A. N. Rice. 2016. Right whale occurrence in the coastal waters of Virginia, USA: Endangered species presence in a rapidly developing energy market. *Marine Mammal Science* 32(2):508-519.
- Salisbury, D. P., B. J. Estabrook, H. Klinck, and A. N. Rice. 2018. Understanding marine mammal presence in the Virginia Offshore Wind Energy Area. OCS Study BOEM 2019-007. US Department of the Interior, Bureau of Ocean Energy Management, Sterling, VA.
- Samuel, Y., S. J. Morreale, C. W. Clark, C. H. Greene, and M. E. Richmond. 2005. Underwater, low-frequency noise in a coastal sea turtle habitat. *Journal of the Acoustical Society of America* 117(3):1465-1472.
- Samuels, A., L. Bejder, and S. Heinrich. 2000. A review of the literature pertaining to swimming with wild dolphins. *Marine Mammal Commission*.
- Santidrián-Tomillo, P., and coauthors. 2017. Secondary nesting beaches for leatherback turtles on the Pacific coast of Costa Rica. *Latin american journal of aquatic research* 45:563-571.

- Santidrián Tomillo, P., and coauthors. 2007. Reassessment of the leatherback turtle (*Dermochelys coriacea*) nesting population at Parque Nacional Marino Las Baulas, Costa Rica: Effects of conservation efforts. *Chelonian Conservation and Biology* 6(1):54-62.
- Sarti Martinez, L., and coauthors. 2007. Conservation and biology of the leatherback turtle in the Mexican Pacific. *Chelonian Conservation and Biology* 6(1):70-78.
- Savoy, T. 2007. Prey eaten by Atlantic sturgeon in Connecticut waters. *American Fisheries Society Symposium* 56:157.
- Savoy, T., L. Maceda, N. K. Roy, D. Peterson, and I. Wirgin. 2017. Evidence of natural reproduction of Atlantic sturgeon in the Connecticut River from unlikely sources. *PLOS ONE* 12(4):e0175085.
- Savoy, T., and D. Pacileo. 2003. Movements and important habitats of subadult Atlantic sturgeon in Connecticut waters. *Transactions of the American Fisheries Society* 132:8-Jan.
- Scales, K. L., and coauthors. 2014. On the Front Line: Frontal zones as priority at-sea conservation areas for mobile marine vertebrates. *Journal of Applied Ecology* 51(6):1575-1583.
- Schaeff, C. M., and coauthors. 1997. Comparison of genetic variability of North and South Atlantic right whales (*Eubalaena*), using DNA fingerprinting. *Canadian Journal of Zoology* 75(7):1073-1080.
- Scheidat, M., and coauthors. 2011. Harbour porpoises (*Phocoena phocoena*) and wind farms: A case study in the Dutch North Sea. *Environmental Research Letters* 6(2):Article 025102.
- Scheifele, P. M., and coauthors. 2005. Indication of a Lombard vocal response in the St. Lawrence River beluga. *Journal of the Acoustical Society of America* 117(3):1486-1492.
- Schmid, J. R., and W. N. Witzell. 1997. Age and growth of wild Kemp's ridley turtles (*Lepidochelys kempii*): Cumulative results of tagging studies in Florida. *Chelonian Conservation and Biology* 2(4):532-537.
- Schofield, G., and coauthors. 2009. Microhabitat selection by sea turtles in a dynamic thermal marine environment. *Journal of Animal Ecology* 78(1):14-21.
- Scholik, A. R., and H. Y. Yan. 2001. Effects of underwater noise on auditory sensitivity of a cyprinid fish. *Hearing Research* 152(2-Jan):17-24.
- Scholik, A. R., and H. Y. Yan. 2002. Effects of boat engine noise on the auditory sensitivity of the fathead minnow, *Pimephales promelas*. *Environmental Biology of Fishes* 63:203-209.
- Schueller, P., and D. L. Peterson. 2010. Abundance and recruitment of juvenile Atlantic sturgeon in the Altamaha River, Georgia. *Transactions of the American Fisheries Society* 139(5):1526-1535.
- Schultze, L., L. Merckelbach, J. Horstmann, S. Raasch, and J. Carpenter. 2020. Increased mixing and turbulence in the wake of offshore wind farm foundations. *Journal of Geophysical Research: Oceans* 125(8):e2019JC015858.
- Schuyler, Q. A., and coauthors. 2016. Risk analysis reveals global hotspots for marine debris ingestion by sea turtles. *Glob Chang Biol* 22(2):567-76.
- Scott, W. B., and E. J. Crossman. 1973. Freshwater fishes of Canada. *Bulletin of the Fisheries Research Board of Canada* 184:1-966.
- Secor, D. H. 2002. Atlantic sturgeon fisheries and stock abundances during the late nineteenth century. *American Fisheries Society Symposium* 2002:89-98.
- Secor, D. H., and coauthors. 2000. Dispersal and growth of yearling Atlantic sturgeon, *Acipenser oxyrinchus*, released into Chesapeake Bay. *Fishery Bulletin* 98(4):800-810.
- Secor, D. H., and coauthors. 2021. Atlantic Sturgeon Status and Movement Ecology in an Extremely Small Spawning Habitat: The Nanticoke River-Marshyhope Creek, Chesapeake Bay. *Reviews in Fisheries Science & Aquaculture*:20-Jan.
- Secor, D. H., and J. R. Waldman. 1999. Historical abundance of Delaware Bay Atlantic sturgeon and potential rate of recovery. *American Fisheries Society Symposium*.

- Seminoff, J. A., and coauthors. 2015a. Status review of the green turtle (*Chelonia mydas*) under the Endangered Species Act. C. Southwest Fisheries Science, editor. National Marine Fisheries Service, Southwest Fisheries Science Center.
- Seminoff, J. A., and coauthors. 2015b. Status review of the green turtle (*Chelonia Mydas*) under the endangered species act. NOAA Technical Memorandum, NMFS-SWFSC-539.
- Seney, E. E. 2003. Historical diet analysis of loggerhead (*Caretta caretta*) and Kemp's ridley (*Lepidochelys kempii*) sea turtles in Virginia. College of William and Mary, Williamsburg, Virginia.
- Seney, E. E. 2016. Diet of Kemp's Ridley Sea Turtles Incidentally Caught on Recreational Fishing Gear in the Northwestern Gulf of Mexico. *Chelonian Conservation and Biology* 15(1):132-137.
- Seney, E. E., and A. M. Landry. 2008. Movements of Kemp's ridley sea turtles nesting on the upper Texas coast: Implications for management. *Endangered Species Research* 4:73-84.
- Seney, E. E., and J. A. Musick. 2007. Historical diet analysis of loggerhead sea turtles (*Caretta caretta*) in Virginia. *Copeia* 2007(2):478-489.
- Sha, J., and coauthors. 2015. A case study of large phytoplankton blooms off the New Jersey coast with multi-sensor observations. *Continental Shelf Research* 107:79-91.
- Shamblin, B. M., and coauthors. 2014. Geographic patterns of genetic variation in a broadly distributed marine vertebrate: new insights into loggerhead turtle stock structure from expanded mitochondrial DNA sequences. *PLOS ONE* 9(1):e85956.
- Shamblin, B. M., and coauthors. 2012. Expanded mitochondrial control region sequences increase resolution of stock structure among North Atlantic loggerhead turtle rookeries. *Marine Ecology Progress Series* 469:145-160.
- Shamblin, B. M., and coauthors. 2016. Mexican origins for the Texas green turtle foraging aggregation: A cautionary tale of incomplete baselines and poor marker resolution. *Journal of Experimental Marine Biology and Ecology* 488:111-120.
- Shaver, D. J., and C. Rubio. 2008. Post-nesting movements of wild and head-started Kemp's ridley sea turtles. Pages 62-63 in M. A. F. F. Rees, A. Panagopoulou, and K. Williams, editors. Twenty-Seventh Annual Symposium on Sea Turtle Biology and Conservation.
- Shaver, D. J., and coauthors. 2005. Movements and home ranges of adult male kemp's ridley sea turtles (*Lepidochelys kempii*) in the Gulf of Mexico investigated by satellite telemetry. *Chelonian Conservation and Biology* 4(4):817-827.
- Shaver, D. J., and T. Wibbels. 2007. Head-starting the Kemp's ridley sea turtle. Pages 297-323 in P. T. Plotkin, editor. *Biology and Conservation of Ridley Sea Turtles*. The Johns Hopkins University Press, Baltimore, Maryland.
- Shillinger, G. L., and coauthors. 2011. Vertical and horizontal habitat preferences of post-nesting leatherback turtles in the South Pacific Ocean. *Marine Ecology Progress Series* 422:275-289.
- Shoop, C. R., and R. D. Kenney. 1992. Seasonal distributions and abundances of loggerhead and leatherback sea turtles in waters of the northeastern United States. University of Rhode Island, Kingston.
- Siedersleben, S. K., and coauthors. 2018. Micrometeorological impacts of offshore wind farms as seen in observations and simulations. *Environmental Research Letters* 13(12):124012.
- Silber, G. K., S. Bettridge, and D. Cottingham. 2009. Report of a workshop to identify and assess technologies to reduce ship strikes of large whales; Providence, Rhode Island 8-10 July 2008. National Oceanic and Atmospheric Administration, National Marine Fisheries Service, Office of Protected Resources.
- Silber, G. K., and coauthors. 2017. Projecting Marine Mammal Distribution in a Changing Climate. *Frontiers in Marine Science* 4.
- Simard, Y., N. Roy, S. Giard, and F. Aulanier. 2019. North Atlantic right whale shift to the Gulf of St. Lawrence in 2015, revealed by long-term passive acoustics. *Endangered Species Research* 40:271-284.



- Simmonds, M. P., and W. J. Elliott. 2009. Climate change and cetaceans: Concerns and recent developments. *Journal of the Marine Biological Association of the United Kingdom* 89(1):203-210.
- Simmonds, M. P., and S. J. Isaac. 2007. The impacts of climate change on marine mammals: Early signs of significant problems. *Oryx* 41(1):19-26.
- Singel, K., A. Foley, T. Redlow, and E. P. Demaye. 2007. Impact of commercial fisheries on sea turtle mortality in Florida. Pages 154 *in* Twenty-Fourth Annual Symposium on Sea Turtle Biology and Conservation.
- Slavik, K., and coauthors. 2019. The large-scale impact of offshore wind farm structures on pelagic primary productivity in the southern North Sea. *Hydrobiologia* 845(1):35-53.
- Smith, M. E., A. B. Coffin, D. L. Miller, and A. N. Popper. 2006. Anatomical and functional recovery of the goldfish (*Carassius auratus*) ear following noise exposure. *Journal of Experimental Biology* 209(21):4193-4202.
- Smith, M. E., A. S. Kane, and A. N. Popper. 2004. Noise-induced stress response and hearing loss in goldfish (*Carassius auratus*). *Journal of Experimental Biology* 207(3):427-435.
- Smith, T. I., E. K. Dingley, and D. E. Marchette. 1980. Induced spawning and culture of Atlantic sturgeon. *The Progressive Fish-Culturist* 42(3):147-151.
- Smith, T. I. J. 1985. The fishery, biology, and management of Atlantic sturgeon, *Acipenser oxyrinchus*, in North America. *Environmental Biology of Fishes* 14(1):61-72.
- Smith, T. I. J., and J. P. Clugston. 1997. Status and management of Atlantic sturgeon, *Acipenser oxyrinchus*, in North America. *Environmental Biology of Fishes* 48(4-Jan):335-346.
- Smith, T. I. J., D. E. Marchette, and G. F. Ulrich. 1984. The Atlantic sturgeon fishery in South Carolina. *North American Journal of Fisheries Management* 4:164-176.
- Smultea Environmental Sciences. 2020. Protected species observer technical report for the Orsted New England IHA, BOEM Lease Areas OCS-A 0486, OCS-A 0487, and OCS-A 0500.
- Smythe, T., D. Bidwell, and G. Tyler. 2021. Optimistic with reservations: The impacts of the United States' first offshore wind farm on the recreational fishing experience. *Marine Policy* 127:104440.
- Snover, M. L., A. A. Hohn, L. B. Crowder, and S. S. Heppell. 2007. Age and growth in Kemp's ridley sea turtles: Evidence from mark-recapture and skeletochronology. P. T. Plotkin, editor. *Biology and Conservation of Ridley Sea Turtles*. The Johns Hopkins University Press, Baltimore, Maryland.
- Soldevilla, M. S., A. J. Debich, L. P. Garrison, J. A. Hildebrand, and S. M. Wiggins. 2022. Rice's whales in the northwestern Gulf of Mexico: call variation and occurrence beyond the known core habitat. *Endangered Species Research* 48:155-174.
- Sorochan, K. A., C. E. Brennan, S. Plourde, and C. L. Johnson. 2021a. Spatial variation and transport of abundant copepod taxa in the southern Gulf of St. Lawrence in autumn. *Journal of Plankton Research* 43(6):908-926.
- Sorochan, K. A., S. Plourde, M. F. Baumgartner, and C. L. Johnson. 2021b. Availability, supply, and aggregation of prey (*Calanus* spp.) in foraging areas of the North Atlantic right whale (*Eubalaena glacialis*). *ICES Journal of Marine Science* 78(10):3498-3520.
- Sorochan, K. A., and coauthors. 2019. North Atlantic right whale (*Eubalaena glacialis*) and its food: (II) interannual variations in biomass of *Calanus* spp. on western North Atlantic shelves. *Journal of Plankton Research* 41(5):687-708.
- Southall, B. 2016. Complementary analyses of behavioral responses to sonar in blue whales (*Balaenoptera musculus*). 2016 Annual Meeting of the Southern California Academy of Sciences, University of Southern California, Ronald Tutor Campus Center.
- Southall, B., W. Ellison, C. Clark, D. Tollit, and J. Amaral. 2021. Marine mammal risk assessment for Gulf of Mexico G&G activities. Southall Environmental Associates. OCS Study BOEM 2021-022, Available at: Marine Mammal Risk Assessment for Gulf of Mexico G&G Activities (boem.gov)



<https://www.boem.gov/sites/default/files/documents/renewable-energy/state-activities/Marine%20Mammal%20Risk%20Assessment%20for%20Gulf%20of%20Mexico%20GG%20Activities.pdf>

- Southall, B. L., and coauthors. 2007a. Marine mammal noise and exposure criteria: initial scientific recommendations. *Aquatic Mammals* 33:411-521.
- Southall, B. L., and coauthors. 2007b. Marine Mammal Noise Exposure Criteria: Initial Scientific Recommendations *Aquatic Mammals*.
- Southall, B. L., D. P. Nowacek, P. J. O. Miller, and P. L. Tyack. 2016. Experimental field studies to measure behavioral responses of cetaceans to sonar. *Endangered Species Research* 31:293-315.
- Spotila, J. 2004. *Sea Turtles: A Complete Guide to their Biology, Behavior, and Conservation*. Johns Hopkins University Press, Baltimore, Maryland.
- Spotila, J. R., and coauthors. 1996. Worldwide population decline of *Dermochelys coriacea*: Are leatherback turtles going extinct? *Chelonian Conservation and Biology* 2(2):209-222.
- Spotila, J. R., R. D. Reina, A. C. Steyermark, P. T. Plotkin, and F. V. Paladino. 2000. Pacific leatherback turtles face extinction. *Nature* 405:529-530.
- Squiers, T. S., and M. Smith. 1979. Distribution and abundance of shortnose and Atlantic sturgeon in the Kennebec River Estuary. Maine Department of Natural Resources.
- SSSRT. 2010. A biological assessment of shortnose sturgeon (*Acipenser brevirostrum*). National Oceanic and Atmospheric Administration, National Marine Fisheries Service, Shortnose Sturgeon Status Review Team, Report to Northeast Regional Office, NMFS, NOAA, U.S. Department of Commerce.
- Stadler, J. H., and D. P. Woodbury. 2009. Assessing the effects to fishes from pile driving: Application of new hydroacoustic criteria. *Inter-noise 2009 - Innovations in Practical Noise Control*, Ottawa, Canada.
- Stein, A. B., K. D. Friedland, and M. Sutherland. 2004a. Atlantic sturgeon marine bycatch and mortality on the continental shelf of the Northeast United States. *North American Journal of Fisheries Management* 24(1):171-183.
- Stein, A. B., K. D. Friedland, and M. Sutherland. 2004b. Atlantic Sturgeon Marine Distribution and Habitat Use along the Northeastern Coast of the United States. *Transactions of the American Fisheries Society* 133(3):527-537.
- Stenberg, C., and coauthors. 2015. Long-term effects of an offshore wind farm in the North Sea on fish communities. *Marine Ecology Progress Series* 528:257-265.
- Stevenson, J. T., and D. H. Secor. 1999. Age determination and growth of Hudson River Atlantic sturgeon *Acipenser oxyrinchus*. *Fishery Bulletin* 98:153-166.
- Stewart, J. D., and coauthors. 2022. Larger females have more calves: influence of maternal body length on fecundity in North Atlantic right whales. *Marine Ecology Progress Series* 689:179-189.
- Stewart, J. D., and coauthors. 2021. Decreasing body lengths in North Atlantic right whales. *Current Biology*.
- Stewart, K. R., and coauthors. 2019. Using mixed stock analysis to assess source populations for at-sea bycaught juvenile and adult loggerhead turtles (*Caretta caretta*) in the north-west Atlantic. *Fish and Fisheries* 20(2):239-254.
- Stober, U., and F. Thomsen. 2021. How could operational underwater sound from future offshore wind turbines impact marine life? *Journal of the Acoustical Society of America* 149(3):1791-1795.
- Stone, K. M., and coauthors. 2017. Distribution and abundance of cetaceans in a wind energy development area offshore of Massachusetts and Rhode Island. *Journal of Coastal Conservation*.
- Sullivan, M. C., R. K. Cowen, K. W. Able, and M. P. Fahay. 2006. Applying the basin model: Assessing habitat suitability of young-of-the-year demersal fishes on the New York Bight continental shelf. *Continental Shelf Research* 26:1551-1570.

- Sweka, J. A., and coauthors. 2007. Juvenile Atlantic Sturgeon Habitat Use in Newburgh and Haverstraw Bays of the Hudson River: Implications for Population Monitoring. *North American Journal of Fisheries Management* 27(4):1058-1067.
- Swingle, W. M., and coauthors. 2017. Virginia Sea Turtle and Marine Mammal Stranding Network 2016 Grant Report: VAQF Scientific Report (Vol 2017 No. 1).
- Swingle, W. M., S. G. Barco, T. D. Pitchford, W. A. McLellan, and D. A. Pabst. 1993. Appearance of juvenile humpback whales feeding in the nearshore waters of Virginia. *Marine Mammal Science* 9(3):309-315.
- Takahashi, R., J. Miyoshi, H. Mizoguchi, and D. Terada. 2019. Comparison of Underwater Cruising Noise in Fuel-Cell Fishing Vessel, Same-Hull-Form Diesel Vessel, and Aquaculture Working Vessel. *Transactions of Navigation* 4(1):29-38.
- Taormina, B., and coauthors. 2018. A review of potential impacts of submarine power cables on the marine environment: Knowledge gaps, recommendations and future directions. *Renewable & Sustainable Energy Reviews* 96:380-391.
- Tapilatu, R. F., and coauthors. 2013. Long-term decline of the western Pacific leatherback, *Dermochelys coriacea*: A globally important sea turtle population. *Ecosphere* 4:15.
- Taylor, B., and coauthors. 2019. *Physeter macrocephalus* (amended version of 2008 assessment). IUCN Red List Threatened Species. <https://dx.doi.org/10.2305/IUCN.UK.2008.RLTS.T41755A160983555.en>.
- Teilmann, J., and J. Carstensen. 2012. Negative long term effects on harbour porpoises from a large scale offshore wind farm in the Baltic—evidence of slow recovery. *Environmental Research Letters* 7(4):45101.
- Teilmann, J., F. Larsen, and G. Desportes. 2007. Time allocation and diving behaviour of harbour porpoises (*Phocoena phocoena*) in Danish and adjacent waters. *Journal of Cetacean Research and Management* 9(3):201-210.
- ten Brink, T. S., and T. Dalton. 2018. Perceptions of Commercial and Recreational Fishers on the Potential Ecological Impacts of the Block Island Wind Farm (US). *Frontiers in Marine Science* 5.
- Tetra Tech. 2022a. Dominion Energy Coastal Virginia Offshore Wind Commercial Project Request for Rulemaking and Letter of Authorization (LOA) for Taking of Marine Mammals Incidental to Construction Activities on the Outer Continental Shelf (OCS) within Lease OCS-A 0483 and the Associated Offshore Export Cable Route Corridor: Roberts and Halpin (2022) Revision Addendum. Prepared for Dominion Energy, Submitted to NOAA National Marine Fisheries Service September 2022, revised December 2022. Tetra Tech, Inc.
- Tetra Tech. 2022b. Dominion Energy Coastal Virginia Offshore Wind Commercial Project, Request for Rulemaking and Letter of Authorization (LOA) for Taking of Marine Mammals Incidental to Construction Activities on the Outer Continental Shelf (OCS) within Lease OCS-A 0483 and the Associated Offshore Export Cable Route Corridor. . Prepared for Dominion Energy, Submitted to NOAA National Marine Fisheries Service February 2022, Revised March, May, June, and July 2022.
- TEWG. 1998. An assessment of the Kemp's ridley (*Lepidochelys kempii*) and loggerhead (*Caretta caretta*) sea turtle populations in the Western North Atlantic. Department of Commerce, Turtle Expert Working Group.
- TEWG. 2000. Assessment update for the Kemp's ridley and loggerhead sea turtle populations in the western North Atlantic. National Oceanic and Atmospheric Administration, National Marine Fisheries Service, Southeast Fisheries Science Center, Turtle Expert Working Group.
- TEWG. 2007a. An Assessment of the Leatherback Turtle Population in the Atlantic Ocean. Pages 116 *in* NOAA Technical Memorandum.

- TEWG. 2007b. An assessment of the leatherback turtle population in the Atlantic Ocean. National Oceanic and Atmospheric Administration, National Marine Fisheries Service, Southeast Fisheries Science Center, Turtle Expert Working Group.
- TEWG. 2009. An assessment of the loggerhead turtle population in the western North Atlantic ocean. National Oceanic and Atmospheric Administration, National Marine Fisheries Service, Turtle Expert Working Group, NMFS-SEFSC-575.
- Thomas, P. O., R. R. Reeves, and R. L. Brownell Jr. 2016. Status of the world's baleen whales. *Marine Mammal Science* 32(2):682-734.
- Thompson, P. M., and coauthors. 2010. Assessing the responses of coastal cetaceans to the construction of offshore wind turbines. *Marine Pollution Bulletin* 60(8):1200-1208.
- Thomsen, F., K. Betke, M. S.-V. Glahn, and W. Piper. 2006a. Noise during offshore wind turbine construction and its effects on harbour porpoises (*Phocoena phocoena*). Pages 24-25 in Twentieth Annual Conference of the European Cetacean Society, Gdynia, Poland.
- Thomsen, F., K. Ludemann, R. Kafemann, and W. Piper. 2006b. Effects of offshore wind farm noise on marine mammals and fish, Hamburg, Germany.
- Tillman, M. F. 1977. Estimates of population size for the North Pacific sei whale. Report of the International Whaling Commission Special Issue 1:98-106.
- Timoshkin, V. P. 1968. Atlantic sturgeon (*Acipenser sturio* L.) caught at sea. *Journal of Ichthyology* 8(4).
- Tiwari, M., Wallace, B.P. & Girondot, M. 2013. *Dermochelys coriacea* (West Pacific Ocean subpopulation). The IUCN Red List of Threatened Species 2013: e.T46967817A46967821.
- Tiwari, R. F. T., T. Wibbels, and Manjula. 2013. Beach and nest temperatures, and estimates of leatherback hatchling sex ratios at bird's head peninsula, Papua, Indonesia. Pages 203 in T. T. L. B. A. P. A. R. M. F. K. W. R. L. K. Stewart, editor Thirty-Third Annual Symposium on Sea Turtle Biology and Conservation. National Oceanic and Atmospheric Administration, National Marine Fisheries Service, Southeast Fisheries Science Center, Baltimore, Maryland.
- Todd, V. L. G., and coauthors. 2015. A review of impacts of marine dredging activities on marine mammals. *ICES Journal of Marine Science* 72(2):328-340.
- Tomas, J., and J. A. Raga. 2008. Occurrence of Kemp's ridley sea turtle (*Lepidochelys kempii*) in the Mediterranean. *Marine Biodiversity Records* 1(1).
- Tønnesen, P., S. Gero, M. Ladegaard, M. Johnson, and P. T. Madsen. 2018. First-year sperm whale calves echolocate and perform long, deep dives. *Behavioral Ecology and Sociobiology* 72(10).
- Tougaard, J., L. Hermannsen, and P. T. Madsen. 2020. How loud is the underwater noise from operating offshore wind turbines? *Journal of the Acoustical Society of America* 148(5):2885-2893.
- Tougaard, J., and coauthors. 2006. Harbour seals on Horns Reef before, during and after construction of Horns Rev Offshore Wind Farm. Final report to Vattenfall A/S. Biological Papers from the Fisheries and Maritime Museum No. 5, Esbjerg, Denmark.
- Tucker, A. D. 2010. Nest site fidelity and clutch frequency of loggerhead turtles are better elucidated by satellite telemetry than by nocturnal tagging efforts: Implications for stock estimation. *Journal of Experimental Marine Biology and Ecology* 383(1):48-55.
- Tyack, P. L. 2000. Dolphins whistle a signature tune. *Science* 289(5483):1310-1311.
- U.S. Department of the Navy (Navy). 2007. Navy OPAREA Density Estimate (NODE) for the Northeast OPAREAs for the Northeast OPAREAs: Boston, Narragansett Bay, and Atlantic City. Prepared for the Department of the Navy, U.S. Fleet Forces Command, Norfolk, Virginia. Contract #N62470-02-D-9997, Task Order 045. Prepared by Geo-Marine, Inc., Hampton, Virginia. Available: <https://seamap.env.duke.edu/downloads/resources/serdp/Northeast%20NODE%20Final%20Report.pdf>.

- U.S. Navy. 2017. Criteria and Thresholds for U.S. Navy Acoustic and Explosive Effects Analysis (Phase III). Space and Naval Warfare Systems Command, U.S. Navy, Department of Defence, San Diego, California.
- Urlick, R. J. 1983. Principles of Underwater Sound, 3rd edition. Peninsula Publishing, Los Altos, California.
- USCG. 2021a. Port Access Route Study (PARS): Approaches to the Chesapeake Bay, VA. Docket Number USCG-2019-0862. United States Coast Guard.
- USCG. 2021b. Port Access Route Study (PARS): Approaches to the Chesapeake Bay, VA. Enclosure 1 - AIS Traffic Density Maps. United States Coast Guard.
- USCG. 2023. Consolidated Port Approaches Port Access Route Studies (PARS). Office of Navigation Systems (CG-NAV) United States Coast Guard.
- USFWS, and NMFS. 2007. Loggerhead sea turtle (*Caretta caretta*) 5-year review: Summary and evaluation. National Marine Fisheries Service and U.S. Fish and Wildlife Service, Silver Spring, Maryland.
- USFWS, N. 1998. Recovery plan for U.S. Pacific populations of the leatherback turtle (*Dermochelys coriacea*). National Oceanic and Atmospheric Administration, National Marine Fisheries Service, Office of Protected Resources, Silver Spring, Maryland.
- USGS, and NSF. 2011. Final Programmatic Environmental Impact Statement/Overseas Environmental Impact Statement for Marine Seismic Research Funded by the National Science Foundation or Conducted by the US Geological Survey. National Science Foundation and United States Geological Survey.
- van Berkel, J., and coauthors. 2020. The effects of offshore wind farms on hydrodynamics and implications for fishes. *Oceanography* 33(4):108-117.
- Van Den Avyle, M. J. 1984. Atlantic Sturgeon. *The Service* 82(11).
- van der Hoop, J., P. Corkeron, and M. Moore. 2017a. Entanglement is a costly life-history stage in large whales. *Ecol Evol* 7(1):92-106.
- van der Hoop, J. M., D. P. Nowacek, M. J. Moore, and M. S. Triantafyllou. 2017b. Swimming kinematics and efficiency of entangled North Atlantic right whales. *Endangered Species Research* 32:1-17.
- Van Eenennaam, J., and coauthors. 1996. Reproductive conditions of the Atlantic sturgeon (*Acipenser oxyrinchus*) in the Hudson River. *Estuaries and Coasts* 19(4):769-777.
- Van Eenennaam, J. P., and S. I. Doroshov. 1998. Effects of age and body size on gonadal development of Atlantic sturgeon. *Journal of Fish Biology* 53(3):624-637.
- Van Parijs, S. M., and coauthors. 2021. NOAA and BOEM minimum recommendations for use of passive acoustic listening systems in offshore wind energy development monitoring and mitigation programs. *Frontiers in Marine Science*:1575.
- Vandepierre, F., and coauthors. 2019. Relative abundance of oceanic juvenile loggerhead sea turtles in relation to nest production at source rookeries: implications for recruitment dynamics. *Scientific Reports* 9(1):13019.
- Vanderlaan, A. S., and C. T. Taggart. 2007. Vessel collisions with whales: The probability of lethal injury based on vessel speed. *Marine Mammal Science* 23(1):144-156.
- Vanhellemont, Q., and K. Ruddick. 2014. Turbid wakes associated with offshore wind turbines observed with Landsat 8. *Remote Sensing of Environment* 145:105-115.
- Vargas, S. M., and coauthors. 2019. Revisiting the genetic diversity and population structure of the critically endangered leatherback turtles in the South-west Atlantic Ocean: insights for species conservation. *Journal of the Marine Biological Association of the United Kingdom* 99(1):31-41.
- Vinhateiro, N., D. Crowley, and D. Mendelsohn. 2018. Deepwater Wind South Fork Wind Farm: Hydrodynamic and Sediment Transport Modeling Results. Appendix I in South Fork Wind Farm and South Fork Export Cable Construction and Operations Plan. Prepared by RPS for Jacobs and Deepwater Wind, South Kingstown, RI.

- Vladykov, V. D., and J. R. Greeley. 1963. Order Acipenseroidei. Pages 24-60 *in* Fishes of Western North Atlantic, volume 1. Memoir Sears Foundation for Marine Research.
- Vladykov, V. D., and J. R. Greely. 1963. Order Acipenseroidei. Fishes of Western North Atlantic. Yale.
- Wada, S., and K.-I. Numachi. 1991. Allozyme analyses of genetic differentiation among the populations and species of the Balaenoptora. Report of the International Whaling Commission Special Issue 13:125-154.
- Waldick, R. C., S. Kraus, M. Brown, and B. N. White. 2002. Evaluating the effects of historic bottleneck events: An assessment of microsatellite variability in the endangered, North Atlantic right whale. *Molecular Ecology* 11(11-Jan):2241-2249.
- Waldman, J. R., J. T. Hart, and I. I. Wirgin. 1996a. Stock composition of the New York Bight Atlantic sturgeon fishery based on analysis of mitochondrial DNA. *Transactions of the American Fisheries Society* 125:364-371.
- Waldman, J. R., and coauthors. 2013. Stock Origins of Subadult and Adult Atlantic Sturgeon, *Acipenser oxyrinchus*, in a Non-natal Estuary, Long Island Sound. *Estuaries and Coasts* 36(2):257-267.
- Waldman, J. R., K. Nolan, J. Hart, and I. I. Wirgin. 1996b. Genetic differentiation of three key anadromous fish populations of the Hudson River. *Estuaries* 19(4):759-768.
- Waldman, J. R., and I. I. Wirgin. 1998. Status and restoration options for Atlantic sturgeon in North America. *Conservation Biology* 12(3):631-638.
- Wallace, B. P., and coauthors. 2010. Regional Management Units for Marine Turtles: A Novel Framework for Prioritizing Conservation and Research across Multiple Scales. *PLOS ONE* 5(12):e15465.
- Wallace, B. P., S. S. Heppell, R. L. Lewison, S. Kelez, and L. B. Crowder. 2008. Impacts of fisheries bycatch on loggerhead turtles worldwide inferred from reproductive value analyses. *Journal of Applied Ecology* 45(4):1076-1085.
- Wallace, B. P., and T. T. Jones. 2008. What makes marine turtles go: A review of metabolic rates and their consequences. *Journal of Experimental Marine Biology and Ecology* 356(2-Jan):24-Aug.
- Wallace, B. P., S. S. Kilham, F. V. Paladino, and J. R. Spotila. 2006. Energy budget calculations indicate resource limitation in Eastern Pacific leatherback turtles. *Marine Ecology Progress Series* 318:263-270.
- Wallace, B. P., and coauthors. 2007. Maternal investment in reproduction and its consequences in leatherback turtles. *Oecologia* 152(1):37-47.
- Wallace, B. P., M. Tiwari, and M. Girondot. 2013. *Dermochelys coriacea*. IUCN Red List of Threatened Species. Version 2013.2.
- Wang, C., and R. G. Prinn. 2010. Potential climatic impacts and reliability of very large-scale wind farms. *Atmos. Chem. Phys.* 10(4):2053-2061.
- Wang, C., and R. G. Prinn. 2011. Potential climatic impacts and reliability of large-scale offshore wind farms. *Environmental Research Letters* 6(2).
- Wang, T., and coauthors. 2018. Zooplankton community responses and the relation to environmental factors from established offshore wind farms within the Rudong coastal area of China. *Journal of Coastal Research* 34(4):843-855.
- Wardle, C. S., and coauthors. 2001. Effects of seismic air guns on marine fish. *Continental Shelf Research* 21:1005-1027.
- Waring, G. T., E. Josephson, K. Maze-Foley, and P. E. Rosel. 2010. U.S. Atlantic and Gulf of Mexico marine mammal stock assessments 2010. Northeast Fisheries Science Center, Woods Hole, Massachusetts.
- Waring, G. T., E. Josephson, K. Maze-Foley, and P. E. Rosel. 2016. US Atlantic and Gulf of Mexico marine mammal stock assessments - 2015. Northeast Fisheries Science Center, Woods Hole, Massachusetts.
- Watkins, W. A. 1977. Acoustic behavior of sperm whales. *Oceanus* 20:50-58.
- Watkins, W. A. 1981. Activities and underwater sounds of fin whales. *Scientific Reports of the Whales Research Institute* 33:83-117.

- Watters, D., M. Yoklavich, M. Love, and D. Schroeder. 2010. Assessing marine debris in deep seafloor habitats off California. *Marine Pollution Bulletin* 60:131-138.
- Watwood, S. L., P. J. O. Miller, M. Johnson, P. T. Madsen, and P. L. Tyack. 2006. Deep-diving foraging behaviour of sperm whales (*Physeter macrocephalus*). *Journal of Animal Ecology* 75:814-825.
- Westerholm, D. A., and S. D. Rauch, III. 2016. Deepwater Horizon oil spill : final programmatic damage assessment and restoration plan and final programmatic environmental impact statement.
- Whitehead, H. 2002. Sperm whale, *Physeter macrocephalus*. Pages 1165-1172 in W. F. P. B. W. J. G. M. Thewissen, editor. *Encyclopedia of Marine Mammals*. Academic Press, San Diego, California.
- Whitehead, H. 2009. Sperm whale: *Physeter macrocephalus*. Pages 1091-1097 in W. F. P. B. W. J. G. M. Thewissen, editor. *Encyclopedia of Marine Mammals*, Second edition. Academic Press, San Diego.
- Whitt, A. D., K. Dudzinski, and J. R. Laliberte. 2013. North Atlantic right whale distribution and seasonal occurrence in nearshore waters off New Jersey, USA, and implications for management. *Endangered Species Research* 20(1):59-69.
- Wibbels, T., and E. Bevan. 2019. *Lepidochelys kempii* (errata version published in 2019). The IUCN Red List of Threatened Species 2019: e.T11533A155057916., The IUCN Red List of Threatened Species 2019: e.T11533A155057916.
- Wilber, D. H., L. Brown, M. Griffin, G. R. DeCelles, and D. A. Carey. 2022. Demersal fish and invertebrate catches relative to construction and operation of North America's first offshore wind farm. *ICES Journal of Marine Science* 79(4):1274–1288.
- Wilber, D. H., and D. G. Clarke. 2001. Biological effects of Suspended Sediments: A Review of Suspended Sediment Impacts on Fish and Shellfish with Relation to Dredging Activities in Estuaries. *North American Journal of Fisheries Management* 21(4):855-875.
- Wiley, D. N., R. A. Asmutis, T. D. Pitchford, and D. P. Gannon. 1995. Stranding and mortality of humpback whales, *Megaptera novaeangliae*, in the mid-Atlantic and southeast United States, 1985-1992. *Fishery Bulletin* 93(1-Jan):196-205.
- Wilkens, J. L., A. W. Katzenmeyer, N. M. Hahn, J. J. Hoover, and B. C. Suedel. 2015. Laboratory test of suspended sediment effects on short-term survival and swimming performance of juvenile Atlantic sturgeon (*Acipenser oxyrinchus oxyrinchus*, Mitchill, 1815). *Journal of Applied Ichthyology* 31(6):984-990.
- Winton, M. V., and coauthors. 2018. Estimating the distribution and relative density of satellite-tagged loggerhead sea turtles using geostatistical mixed effects models. *Marine Ecology Progress Series* 586:217-232.
- Wippelhauser, G. S. 2012. A Regional Conservation Plan For Atlantic Sturgeon in the U. S. Gulf of Maine. Maine Department of Marine Resources, Augusta, ME.
- Wippelhauser, G. S., and T. S. Squiers. 2015. Shortnose Sturgeon and Atlantic Sturgeon in the Kennebec River System, Maine: a 1977-2001 Retrospective of Abundance and Important Habitat. *Transactions of the American Fisheries Society* 144(3):591-601.
- Wirgin, I., and coauthors. 2015a. Origin of Atlantic Sturgeon Collected off the Delaware Coast during Spring Months. *North American Journal of Fisheries Management* 35(1):20-30.
- Wirgin, I., and T. King. 2011. Mixed stock analysis of Atlantic sturgeon from coastal locales and a non-spawning river. NMFS Northeast Region Sturgeon Workshop, Alexandria, Virginia.
- Wirgin, I., L. Maceda, C. Grunwald, and T. L. King. 2015b. Population origin of Atlantic sturgeon *Acipenser oxyrinchus oxyrinchus* by-catch in U.S. Atlantic coast fisheries. *Journal of Fish Biology* 86(4):1251-70.
- Wirgin, I., and coauthors. 2012. Stock Origin of Migratory Atlantic Sturgeon in Minas Basin, Inner Bay of Fundy, Canada, Determined by Microsatellite and Mitochondrial DNA Analyses. *Transactions of the American Fisheries Society* 141(5):1389-1398.

- Witherington, B., M. Bresette, and R. Herren. 2006. *Chelonia mydas* - Green turtle. Chelonian Research Monographs 3:90-104.
- Witherington, B., P. Kubilis, B. Brost, and A. Meylan. 2009. Decreasing annual nest counts in a globally important loggerhead sea turtle population. *Ecological Applications* 19(1):30-54.
- Witzell, W. N. 1983. Synopsis of biological data on the hawksbill sea turtle, *Eretmochelys imbricata* (Linnaeus, 1766). Food and Agricultural Organization of the United Nations, Rome.
- Witzell, W. N. 2002. Immature Atlantic loggerhead turtles (*Caretta caretta*): Suggested changes to the life history model. *Herpetological Review* 33(4):266-269.
- Work, P. A., A. L. Sapp, D. W. Scott, and M. G. Dodd. 2010. Influence of small vessel operation and propulsion system on loggerhead sea turtle injuries. *Journal of Experimental Marine Biology and Ecology* 393(2-Jan):168-175.
- Wuebbles, D. J., and coauthors. 2017. Climate Science Special Report: Fourth National Climate Assessment, Volume I. U.S. Global Change Research Program, Washington, District of Columbia.
- Wursig, B., C. R. Greene, and T. A. Jefferson. 2000. Development of an air bubble curtain to reduce underwater noise of percussive piling. *Marine Environmental Research* 49(1):79-93.
- Wysocki, L. E., S. Amoser, and F. Ladich. 2007. Diversity in ambient noise in European freshwater habitats: Noise levels, spectral profiles, and impact on fishes. *Journal of the Acoustical Society of America* 121(5):2559-2566.
- Wysocki, L. E., J. P. Dittami, and F. Ladich. 2006. Ship noise and cortisol secretion in European freshwater fishes. *Biological Conservation* 128(4):501-508.
- Young, C. N., and coauthors. 2018. Status Review Report: Oceanic Whitetip Shark (*Carcharhinus longimanus*). Final Report to the National Marine Fisheries Service, Office of Protected Resources:170.
- Young, C. N., and J. K. Carlson. 2020. The biology and conservation status of the oceanic whitetip shark (*Carcharhinus longimanus*) and future directions for recovery. *Reviews in Fish Biology and Fisheries* 30(2):293-312.
- Youngkin, D. A. 2001. A long-term dietary analysis of loggerhead sea turtles (*Caretta caretta*) based on strandings from Cumberland Island, Georgia. Charles E. Schmidt College of Science, Florida Atlantic University, Boca Raton, Florida.
- Zug, G. R., H. J. Kalb, and S. J. Luzzar. 1997. Age and growth in wild Kemp's ridley sea turtles *Lepidochelys kempii* from skeletochronological data. *Biological Conservation* 80(3):261-268.
- Zurita, J. C., and coauthors. 2012. Age at first nesting of green turtles in the Mexican Caribbean. Pages 75 in T. T. J. B. P. Wallace, editor Thirty-First Annual Symposium on Sea Turtle Biology and Conservation. National Oceanic and Atmospheric Administration, National Marine Fisheries Service, Southeast Fisheries Science Center, San Diego, California.
- Zurita, J. C., and coauthors. 2003. Nesting loggerhead and green sea turtles in Quintana Roo, Mexico. Pages 25-127 in J. A. Seminoff, editor Twenty-Second Annual Symposium on Sea Turtle Biology and Conservation, Miami, Florida.
- Zwinnenberg, A. J. 1977. Kemp's ridley, *Lepidochelys kempii* (Garman, 1880), undoubtedly the most endangered marine turtle today (with notes on the current status of *Lepidochelys olivacea*). *Bulletin of the Maryland Herpetological Society* 13(3):170-192.



**15 APPENDIX A: PROPOSED MITIGATION, MONITORING, AND REPORTING MEASURES IN THE BA.**

**15.1 Copy of Table 1-7 in BOEM’s BA: Mitigation, monitoring, and reporting measures committed to by the Applicant.**

	Activity	Measure	Description	Project Phase
1	General	Agency & Consultation Conditions	The Applicant will adhere to any additional requirements for the Proposed Action set forth by MMPA and ESA consultations as well as BOEM PDCs/BMPs, and ROD conditions.	Construction, O&M, Decommissioning
2	General	PSO standards and responsibilities	<ul style="list-style-type: none"> <li>• PSOs must be provided by a third-party provider.</li> <li>• PSO and PAM operators will have completed NMFS-approved PSO training, and have team leads with experience in the northwestern Atlantic Ocean on similar projects; remaining PSOs and PAM operators will have previous experience on similar projects and the ability to work with the relevant software; PSOs and PAM operators will complete a Permits and Environmental Compliance training and a two-day training and refresher session with the PSO provider and the Project compliance representatives before the anticipated start of Project activities.</li> <li>• PSOs will check the NOAA Fisheries website daily for DMA locations.</li> <li>• PSOs will work in shifts such that no one monitor will work more than 4 consecutive hours without a consecutive 2-hour break or longer than 12 hours during any 24-hour period.</li> <li>• PSOs will be responsible for visually monitoring and identifying ESA-listed species approaching or entering the established clearance and shutdown zones during Project activities.</li> <li>• PSOs will be equipped with reticule binoculars and have the ability to estimate distances to ESA-listed species located in proximity to their established zones. Range finders will also be available for PSOs to use as appropriate. Digital single-lens reflex camera equipment will be used to record sightings and verify species identity.</li> <li>• Observations will take place from the highest available vantage point.</li> <li>• General 360-degree scanning will occur during the monitoring periods, and target scanning by PSOs will occur when alerted of an ESA-listed species presence.</li> <li>• All data will be recorded using industry-standard software.</li> <li>• Data recorded will include information related to ongoing operations, observation methods and effort, visibility conditions, protected species detections, and any mitigation actions requested and enacted.</li> </ul>	Construction, O&M, Decommissioning



	Activity	Measure	Description	Project Phase
3	General	Vessel strike avoidance policy	<ul style="list-style-type: none"> <li>The Project will implement a vessel strike avoidance policy for all vessels under contract to Dominion Energy to reduce the risk of vessel strikes, and the likelihood of death, serious injury, or both to marine mammals, sea turtles, or ESA-listed fish that may result from collisions with vessels.</li> <li>Vessel operators and crews shall receive site-specific training on marine mammal, sea turtle, and ESA-listed fish sighting/reporting and vessel strike avoidance measures.</li> <li>All attempts shall be made to remain parallel to the animal's course when a travelling marine mammal is sighted in proximity to the vessel in transit. All attempts shall be made to reduce any abrupt changes in vessel direction until the marine mammal has moved beyond its associated separation distance.</li> <li>If an animal or group of animals is sighted in the vessel's path or in proximity to it, or if the animals are behaving in an unpredictable manner, all attempts shall be made to divert away from the animals or, if unable due to restricted movements, reduce speed and shift gears into neutral until the animal(s) has moved beyond the associated separation distance (except for voluntary approach and bow riding dolphin species).</li> <li>All vessels will employ a dedicated lookout during all operations (will be filled by PSOs when PSOs are required for specified mitigation and monitoring activities).</li> <li>All vessels will comply with NMFS regulations and speed restrictions and state regulations as applicable for NARW.</li> <li>All vessels regardless of size operating from November 1 through April 30 will operate at speeds of 10 knots or less when transiting from port to port within the Lease Area and export cable route, or within the boundaries of any DMA, slow zone, or SMA.</li> </ul>	Construction, O&M, Decommissioning
4	General	Vessel separation distances	<ul style="list-style-type: none"> <li>Vessels will maintain, to the extent practicable, separation distances of:                             <ul style="list-style-type: none"> <li>&gt;1,640-ft (500-m) distance from the NARW and unidentified large whale;</li> <li>&gt;328 ft (100 m) from sperm whales and non-ESA-listed baleen whales;</li> <li>&gt;164 ft (50 m) for dolphins, porpoises, seals, and sea turtles.</li> </ul> </li> </ul>	Construction, O&M, Decommissioning
5	General	Vessel speed restrictions	<ul style="list-style-type: none"> <li>All vessels 65 ft (20 m) or larger operating from November 1 through April 30 will operate at speeds of 10 knots or less.</li> <li>All vessels will comply with NMFS regulations and speed restrictions and state regulations as applicable for NARW.</li> <li>All Project-related vessels will comply with 10 knot speed restrictions in any SMA, DMA, or Slow Zone.</li> <li>All Project-related vessels will reduce vessel speed to 10 knots or less when mother/calf pairs, pods, or larger assemblages of whales are observed near an underway vessel.</li> <li>If an animal is sighted within their respective separation distance, vessels must steer a course away from the animal at 10 knots or less until the minimum separate distance is established</li> </ul>	Construction, O&M, decommissioning

	Activity	Measure	Description	Project Phase
6	General	Situational Awareness System/Common Operating Picture	<p>CVOW-C Monitoring and Coordination Center (MCC) will establish and maintain a Common Operating Procedure detailing the monitoring, project communication and external reporting requirements associated with marine mammal and sea turtle detections. Members of the MCC monitoring team will consult with NMFS NARW reporting system for the presence of NARW in Project area and vessel transit routes.</p> <p>Monitoring activities will include a combination of the following:</p> <ul style="list-style-type: none"> <li>• Minimum of daily monitoring of sighting communication tools such as Mysticetus, Whale Alert, WhaleMap, WhaleAlert during project construction, operation and maintenance activities.</li> <li>• Regular monitoring of the USCG VHF Channel 16 to receive notifications of any DMA, SMA, or Slow Zone.</li> <li>• Monitoring of any real-time acoustic networks.</li> <li>• Platform for communicating sighting information to all Project vessels.</li> <li>• Process for reporting sightings to appropriate external parties and regulatory agencies.</li> <li>• Identification of responsible positions for monitoring and reporting responsibilities.</li> <li>• During pile installation, in the two days prior to and daily throughout construction, the lead of the PSO monitoring team will consult with NMFS NARW reporting systems for the presence of NARW.</li> <li>• If a NARW is confirmed through any of the above-mentioned monitoring tools or alerts, then the vessel captain, Lead PSO onboard, or the MCC will notify the Right Whale Sighting Advisory System hotline immediately and no later than within 24 hours.</li> </ul>	Construction, O&M, decommissioning
7	Foundation Installation	Foundation installation: Pile-driving time-of-year restriction	Pile driving of foundations and pile driving associated with installation of the goal post piles for Trenchless Installation will not occur from November 1 through April 30.	Construction
8		Foundation installation: Noise mitigation systems	The Project will use a noise mitigation system for all impact and vibratory piling events for foundation installation. Dominion Energy will achieve the sound levels at the ranges that correspond to the isopleths modeled using the 10 dB reduction and will verify these ranges in field measurements.	Construction
9	Foundation Installation	Sound field verification (SFV) measurement plan	<p>An SFV measurement plan will be submitted to NMFS and BOEM for review and approval at least 120 days prior to the planned start of pile driving.</p> <p>The plan will describe how Dominion Energy will ensure the location selected is representative of the rest of the piles of that type to be installed.</p> <p>The plan will also describe how the effectiveness of the sound attenuation methodology will be evaluated based on the results.</p>	Construction

	Activity	Measure	Description	Project Phase
10	Foundation Installation	Sound measurements and Level A / B harassment distance verification	<p>Dominion Energy will conduct field verification measurements of impact and vibratory pile driving during installation of the WTG foundations for model validation purposes and to further determine the effectiveness of the mitigation measures employed.</p> <ul style="list-style-type: none"> <li>SFV measurements will be conducted during installation of the first three monopiles installed over the course of the Project.</li> <li>If pile driving occurs across different seasons, SFV measurements will also be conducted during installation of a monopile in a season that differs from the season of the first monopile measured for comparison purposes (i.e., if the first monopile is installed in the spring and pile driving also occurs in the fall, SFV measurements will occur on a pile installed in the fall).</li> <li>If Dominion Energy receives technical information that indicates a subsequent monopile is likely to produce larger sound fields than modeled or previously measured, they will conduct measurements on that monopile with the potentially larger sound field.</li> <li>Dominion Energy will provide initial results of the SFV measurements to NMFS as soon as they are processed.</li> <li>Measurements will be conducted at distances of approximately 2,460 ft (750 m), 8,202 ft (2,500 m), and 16,404 ft (5,000 m) from the pile being installed as well as the extent of the Level B harassment zones to verify the accuracy of the modeled zones.</li> <li>Recordings will be continuous throughout the duration of all impact hammering of each pile monitored.</li> <li>The measurement systems will have a sensitivity appropriate for the expected sound levels received from pile driving at the nominal ranges through the installation of the pile.</li> <li>The dynamic range of the system will be sufficient such that at each location, pile-driving signals are not clipped and are not masked by noise floor.</li> </ul>	Construction
11	Foundation Installation	Adaptive management of SFV measurements	<ul style="list-style-type: none"> <li>If the initial SFV measurements indicate distances to the isopleths corresponding to the Level A and B harassment zones are less than the distances predicted by modeling assuming 10 dB noise attenuation, Dominion Energy may request a modification of the clearance and shutdown zones for impact pile driving.</li> <li>For the modification request to be considered by NMFS, Dominion Energy must have conducted SFV measurement on a least three piles to verify that the zone sizes are consistently smaller than predicted by modeling.</li> <li>The adjusted clearance zones will be based on the maximum Level A harassment distance measured for that hearing group.</li> <li>If the SFV measurements indicated the need for extended clearance and shutdown zones, a plan outlining a combination of enhanced PAM and visual monitoring will be developed and implemented, including the potential addition of dedicated PSO vessels.</li> </ul>	Construction

	Activity	Measure	Description	Project Phase
12	Foundation Installation	Time of day restrictions for pile driving	<ul style="list-style-type: none"> <li>• Pile driving of the foundations will commence only during daylight hours no earlier than 1 hour after civil sunrise.</li> <li>• Pile driving of foundations will not be initiated later than 1.5 hours before civil sunset.</li> <li>• Pile driving of the foundations may continue after dark when the installation of the same pile began during daylight, when visual clearance zones were fully visible for the 60 minutes immediately prior to civil sunset, and pile driving must proceed for human safety or installation feasibility reasons.</li> <li>• Pile driving will not be initiated in times of low visibility when visual clearance zones cannot be visually monitored, as determined by the Lead PSO.</li> </ul>	Construction
13	Foundation Installation	Daytime visual monitoring ( <i>Daytime is defined by the period between nautical twilight rise and set for the region</i> )	<ul style="list-style-type: none"> <li>• A minimum of two PSOs will be on active duty at the foundation pile driving vessel/platform from 60 minutes before and during, and for 30 minutes after pile installation activity.</li> <li>• Each PSO will use big eye (25x) binoculars that will be spaced 180 degrees apart to maximize coverage of clearance and shutdown zones for all protected species. The big eye binoculars will be placed at a deck height expected to achieve monitoring of minimum distances.</li> <li>• PSOs will continuously scan from 90 degrees right to 90 degrees left for full coverage of their half of the monitoring zone.</li> <li>• Any dedicated PSO vessel(s) will be located at the best vantage point (distance from the pile driving vessel) to observe and document ESA-listed species in proximity to the clearance, shutdown zones, or both.</li> <li>• PSOs on the dedicated PSO vessel will have reticle binoculars, and if deemed appropriate and effective for the PSO vessel, big eye binoculars.</li> <li>• Should more than one dedicated PSO vessel be in operation, the PSO vessels will operate in positions directly opposite each other to ensure coverage of the clearance, shutdown zones, or both.</li> </ul>	Construction
14	Foundation Installation	Daytime visual monitoring during periods of reduced visibility	<ul style="list-style-type: none"> <li>• If the clearance and shutdown zones are visually obscured, the PSOs on watch will continue to monitor the zones using reduced visibility monitoring tools such as night vision devices, infrared, thermal camera systems, or both.</li> <li>• All visual PSOs on duty will be in contact (through the Lead PSO) with the on-duty PAM operator who will monitor the PAM systems for acoustic detections of marine mammals that are vocalizing in the area.</li> </ul>	Construction

	Activity	Measure	Description	Project Phase
15	Foundation Installation	Nighttime visual monitoring (if required)	<p>Pile driving during nighttime hours could potentially occur when a pile installation is started during daylight and, due to unforeseen circumstances, would need to be finished after dark. New piles will not be initiated after dark.</p> <p>If piling extends into nighttime periods, the following actions will be taken:</p> <ul style="list-style-type: none"> <li>Visual PSOs will rotate in pairs: one observing with a handheld night vision devices (NVD) and one monitoring an infrared/thermal imaging camera system. Deck lights will be extinguished or dimmed during night observations when using night-vision devices; however, if the deck lights must remain on for safety reasons, the PSO will attempt to use the NVD in areas away from potential interference by these lights. If a PSO is unable to monitor the visual clearance or shutdown zones with available NVDs. Piling will be halted (as safe to do so).</li> <li>A PAM operator will monitor the PAM systems for acoustic detections of ESA-listed marine mammals vocalizing in the area.</li> </ul>	Construction
16	Foundation Installation	PAM for pile driving	<ul style="list-style-type: none"> <li>PAM will occur during all foundation installation activities and will supplement the visual monitoring program during all pre-start clearance periods, piling, and post-piling monitoring periods.</li> <li>PAM will be designed and established such that detection capability extends to at least 3 miles (5 km) from the pile-driving location (though it will extend farther if available technology at the time of construction allows) for all foundations.</li> <li>The NARW acoustic clearance zone is 'at any distance' and Dominion Energy will monitor out to at least 5 km.</li> <li>The selected PAM system will transmit real time data to PAM monitoring stations on the vessels, a shore side monitoring station, or both.</li> <li>PAM will begin 60 minutes prior to the initiation of the soft-start, throughout foundation installation, and for 30 minutes after pile driving has been completed.</li> <li>PAM will be conducted by a dedicated, qualified, and NMFS-approved PAM operator(s).</li> <li>PAM operator(s) will monitor the hydrophone signal in real time both aurally (using headphones) and visually (via the monitor screen displays).</li> <li>PAM operators will communicate detections of any marine mammals to the Lead PSO who will ensure the implementation of the appropriate mitigation measures</li> <li>A PAM detection alone (i.e., in the absence of visual confirmation by a PSO) will not trigger mitigation measures, with the exception of a confirmed PAM detection of NARW at any distance.</li> </ul>	Construction

	Activity	Measure	Description	Project Phase																																												
17	Foundation Installation	Clearance and shutdown zones for impact pile driving	<p align="center"><b>Clearance and shutdown zones for Impact Pile Driving of Foundations</b></p> <p>Table 4. Clearance and Shutdown Zones for Impact Pile Driving</p> <table border="1"> <thead> <tr> <th rowspan="2">Species</th> <th colspan="2">Clearance Zone (m)</th> <th colspan="2">Shutdown Zone (m)</th> </tr> <tr> <th>One per Day</th> <th>Two per Day</th> <th>One per Day</th> <th>Two per Day</th> </tr> </thead> <tbody> <tr> <td>North Atlantic right whale – PAM</td> <td>at any distance</td> <td>at any distance</td> <td>at any distance</td> <td>at any distance</td> </tr> <tr> <td>North Atlantic right whale – visual detection</td> <td>at any distance, minimum 1,750</td> <td>at any distance, minimum 1,750</td> <td>at any distance, minimum 1,750</td> <td>at any distance, minimum 1,750</td> </tr> <tr> <td>All other Mysticetes and sperm whales</td> <td>5,100</td> <td>6,500</td> <td>1,750</td> <td>1,750</td> </tr> <tr> <td>Harbor porpoise</td> <td>750</td> <td>750</td> <td>750</td> <td>750</td> </tr> <tr> <td>Dolphins and pilot whales</td> <td>500</td> <td>500</td> <td>500</td> <td>500</td> </tr> <tr> <td>Seals</td> <td>500</td> <td>500</td> <td>500</td> <td>500</td> </tr> <tr> <td>Sea Turtles</td> <td>1,000</td> <td>1,000</td> <td>100</td> <td>100</td> </tr> </tbody> </table> <p>Notes: Clearance and shutdown zones account for practicality concerns, including the functional effective distances for visual monitoring as based on experiences from the CVOW Pilot Project. Note for high frequency cetaceans, the peak PTS distance was used given the small size of harbor porpoises and the likely visible identification range. In general, if the modeled PTS distance was less than 100 m, the clearance zone was set at 250 m; whereas if the modeled zone was greater than 100 m but less than 500 m, it was set at 500 m.</p>	Species	Clearance Zone (m)		Shutdown Zone (m)		One per Day	Two per Day	One per Day	Two per Day	North Atlantic right whale – PAM	at any distance	at any distance	at any distance	at any distance	North Atlantic right whale – visual detection	at any distance, minimum 1,750	at any distance, minimum 1,750	at any distance, minimum 1,750	at any distance, minimum 1,750	All other Mysticetes and sperm whales	5,100	6,500	1,750	1,750	Harbor porpoise	750	750	750	750	Dolphins and pilot whales	500	500	500	500	Seals	500	500	500	500	Sea Turtles	1,000	1,000	100	100	Construction
Species	Clearance Zone (m)		Shutdown Zone (m)																																													
	One per Day	Two per Day	One per Day	Two per Day																																												
North Atlantic right whale – PAM	at any distance	at any distance	at any distance	at any distance																																												
North Atlantic right whale – visual detection	at any distance, minimum 1,750	at any distance, minimum 1,750	at any distance, minimum 1,750	at any distance, minimum 1,750																																												
All other Mysticetes and sperm whales	5,100	6,500	1,750	1,750																																												
Harbor porpoise	750	750	750	750																																												
Dolphins and pilot whales	500	500	500	500																																												
Seals	500	500	500	500																																												
Sea Turtles	1,000	1,000	100	100																																												
18	Foundation Installation	Clearance and shutdown zones for vibratory	<p align="center"><b>Clearance and shutdown zones during vibratory pile driving of foundations</b></p> <p>Table 5. Clearance and Shutdown Zones (Vibratory Pile Driving for Foundations)</p> <table border="1"> <thead> <tr> <th rowspan="2">Species</th> <th colspan="2">Clearance zone (m)</th> <th colspan="2">Shutdown zone (m)</th> </tr> <tr> <th>One Per Day</th> <th>Two per Day</th> <th>One Per Day</th> <th>Two per Day</th> </tr> </thead> <tbody> <tr> <td>North Atlantic right whale – PAM</td> <td>at any distance</td> <td>at any distance</td> <td>at any distance</td> <td>at any distance</td> </tr> <tr> <td>North Atlantic right whale – visual detection</td> <td>at any distance, minimum 1,750</td> <td>at any distance, minimum 1,750</td> <td>at any distance, minimum 1,750</td> <td>at any distance, minimum 1,750</td> </tr> <tr> <td>All other Mysticetes and sperm whales</td> <td>1,000</td> <td>1,000</td> <td>1,000</td> <td>1,000</td> </tr> <tr> <td>Harbor porpoise</td> <td>500</td> <td>500</td> <td>500</td> <td>500</td> </tr> <tr> <td>Dolphins and pilot whales</td> <td>250</td> <td>250</td> <td>250</td> <td>250</td> </tr> <tr> <td>Seals</td> <td>250</td> <td>250</td> <td>250</td> <td>250</td> </tr> <tr> <td>Sea Turtles</td> <td>1,000</td> <td>1,000</td> <td>100</td> <td>100</td> </tr> </tbody> </table> <p>Notes: Clearance and shutdown zones account for practicality concerns, including the functional effective distances for visual monitoring as based on experiences from the CVOW Pilot Project. In general, if the modeled PTS distance was less than 100 m, the clearance zone was set at 250 m; whereas if the modeled zone was greater than 100 m but less than 500 m, it was set at 500 m.</p>	Species	Clearance zone (m)		Shutdown zone (m)		One Per Day	Two per Day	One Per Day	Two per Day	North Atlantic right whale – PAM	at any distance	at any distance	at any distance	at any distance	North Atlantic right whale – visual detection	at any distance, minimum 1,750	at any distance, minimum 1,750	at any distance, minimum 1,750	at any distance, minimum 1,750	All other Mysticetes and sperm whales	1,000	1,000	1,000	1,000	Harbor porpoise	500	500	500	500	Dolphins and pilot whales	250	250	250	250	Seals	250	250	250	250	Sea Turtles	1,000	1,000	100	100	Construction
Species	Clearance zone (m)		Shutdown zone (m)																																													
	One Per Day	Two per Day	One Per Day	Two per Day																																												
North Atlantic right whale – PAM	at any distance	at any distance	at any distance	at any distance																																												
North Atlantic right whale – visual detection	at any distance, minimum 1,750	at any distance, minimum 1,750	at any distance, minimum 1,750	at any distance, minimum 1,750																																												
All other Mysticetes and sperm whales	1,000	1,000	1,000	1,000																																												
Harbor porpoise	500	500	500	500																																												
Dolphins and pilot whales	250	250	250	250																																												
Seals	250	250	250	250																																												
Sea Turtles	1,000	1,000	100	100																																												
19	Foundation Installation	Pre-start clearance	<ul style="list-style-type: none"> <li>• Dominion Energy will implement a 60-minute clearance period of the clearance zones prior to impact pile driving for the foundations.</li> <li>• If a marine mammal or sea turtle is observed entering or within the relevant shutdown zones prior to the initiation of pile driving activity, pile driving activity will be delayed and will not begin until either the marine mammal(s) or sea turtle(s) has voluntarily left the respective clearance zones and been visually or acoustically confirmed beyond that shutdown zone, or when the additional time period has elapsed with no further sighting or acoustic detection (i.e., 15 minutes for small odontocetes and 30 minutes for all other marine mammal species, 60 minutes for sea turtles).</li> <li>• PSOs will apply a clearance zone of 3,280 ft (1,000 m) for all species of sea turtle, however the shutdown zone for sea turtles remains at 328 ft (100 m).</li> </ul>	Construction																																												

	Activity	Measure	Description	Project Phase
20	Foundation Installation	Soft-start (ramp up) for impact pile driving	<ul style="list-style-type: none"> <li>A soft-start will occur at the beginning of the impact pile driving of each pile and at any time following the cessation of impact pile driving of 30 minutes or longer. The soft-start requires an initial 30 minutes using a reduced hammer energy for pile driving.</li> <li>An Operating Procedure will be developed to document the soft-start process incorporating final project design including specific hammer energies.</li> <li>Soft-start procedure will not begin until the marine mammal and sea turtle clearance zones have been cleared by the visual PSOs and PAM operators.</li> <li>If a marine mammal or sea turtle is detected within or about to enter the applicable clearance zone, prior to or during the soft-start procedure, pile driving will be delayed until the animal has been observed exiting the clearance zone or until an additional time period has elapsed with no further sighting (i.e., 15 minutes for small odontocetes and 30 minutes for all other marine mammal species, and 60 minutes for sea turtles).</li> <li>Soft-starts are not feasible for vibratory pile driving and will not be implemented for vibratory piling. All remaining pre-start clearance protocols will be followed prior to initiating vibratory piling.</li> </ul>	Construction
21	Foundation Installation	Shutdowns	<ul style="list-style-type: none"> <li>If a marine mammal or sea turtle is detected entering or within the respective shutdown zones after pile driving has commenced, an immediate shutdown of pile driving will be implemented when practicable as determined by the lead engineer on duty who will determine if a shutdown is safe and practicable.</li> <li>If shutdown is called for but it is determined that shutdown is not feasible due to risk of injury or loss of life, there will be a reduction of hammer energy.</li> <li>Following shutdown, pile driving will only be initiated once the animal has been observed exiting its respective clearance zone within 30 minutes of the shutdown, or if an additional time period has elapsed with no further sightings (i.e., 15 minutes for small odontocetes, 30 minutes for all other marine mammal species, and 30 minutes for sea turtles).</li> <li>The shutdown zone and clearance zone will be continually monitored by PSOs and PAM operators during any pauses in pile driving.</li> <li>If pile driving shuts down for reasons other than mitigation (e.g., mechanical difficulty) for periods less than 30 minutes, pile driving may restart without soft-start if PSOs have maintained constant observations and no detections of any marine mammal or sea turtles in the clearance zone have occurred.</li> </ul>	Construction
22	Foundation Installation	Post-impact piling monitoring	PSOs will continue to survey the clearance and shutdown zones and surrounding waters throughout the duration of pile installation and for a minimum of 30 minutes after piling has been completed.	Construction



	Activity	Measure	Description	Project Phase
23	Trenchless Installation of Export Cable	Time of day restrictions for pile driving during trenchless installations	<ul style="list-style-type: none"> <li>Pile driving for any trenchless installation will commence only during daylight hours no earlier than 1 hour after civil sunrise and will be completed no later than 1 hour before civil sunset.</li> <li>Pile driving of goal posts or cofferdams may continue after dark when the installation of the same pile began during daylight, when visual clearance zones were fully visible for the 30 minutes immediately prior to civil sunset, and pile driving must proceed for human safety or installation feasibility reasons.</li> <li>Pile driving will not be initiated in times of low visibility when visual clearance zones cannot be visually monitored.</li> </ul>	Construction
24	Trenchless Installation of Export Cable	Daytime visual monitoring ( <i>Daytime is defined by the period between nautical twilight rise and set for the region</i> )	<ul style="list-style-type: none"> <li>A minimum of two PSOs will be on active duty at the goal post or cofferdam pile driving platform, or on a vessel nearby the construction vessel, from 30 minutes before, during, and 30 minutes after pile driving.</li> <li>Any additional PSO vessels will remain in contact with the Lead PSO.</li> <li>Each PSO on watch will use reticle binoculars and, if deemed feasible and effective for the vessel, Big Eye binoculars.</li> </ul>	Construction
25	Trenchless Installation of Export Cable	Daytime visual monitoring during periods of reduced visibility	If the clearance and shutdown zones are visually obscured, the PSOs on watch will continue to monitor the zones using reduced visibility monitoring tools such as night vision devices, infrared, thermal camera systems, or both.	Construction
26		Nighttime visual monitoring (if required)	<ul style="list-style-type: none"> <li>While not expected, pile driving during nighttime hours could potentially occur when a pile installation is started during daylight and, due to unforeseen circumstances, would need to be finished after dark.</li> <li>New piles will not be initiated after dark.</li> <li>Visual PSOs will rotate in pairs: one observing with a handheld NVD and one monitoring an infrared/thermal imaging camera system.</li> <li>Deck lights will be extinguished or dimmed during night observations when using night-vision devices; however, if the deck lights must remain on for safety reasons, the PSO will attempt to use the NVD in areas away from potential interference by these lights.</li> <li>If a PSO is unable to monitor the visual clearance or shutdown zones with available tools, piling will not commence or will be halted (as safe to do so).</li> <li>No PAM monitoring will be conducted for trenchless installations</li> </ul>	Construction



	Activity	Measure	Description	Project Phase																					
27	Trenchless Installation of Export Cable	Clearance and shutdown zones for impact pile driving during trenchless installations	<p><b>Clearance and shutdown zones for Project impact pile driving during trenchless installations (i.e., goal post piles)</b></p> <p>Table 7. Clearance and Shutdown Zones for Goal Post Installation</p> <table border="1"> <thead> <tr> <th>Species</th> <th>Clearance zone (m)</th> <th>Shutdown zone (m)</th> </tr> </thead> <tbody> <tr> <td>North Atlantic right whale – visual detection</td> <td>at any distance</td> <td>at any distance</td> </tr> <tr> <td>All other Mysticetes, sperm whales, and pilot whales</td> <td>1,000</td> <td>1,000</td> </tr> <tr> <td>Harbor porpoise</td> <td>750</td> <td>100</td> </tr> <tr> <td>Dolphins and pilot whales</td> <td>250</td> <td>100</td> </tr> <tr> <td>Seals</td> <td>500</td> <td>100</td> </tr> <tr> <td>Sea Turtles</td> <td>1,000</td> <td>100</td> </tr> </tbody> </table> <p>Note: Clearance and shutdown zones proposed based on distances to NOAA Fisheries harassment criteria (NOAA Fisheries 2018a).</p>	Species	Clearance zone (m)	Shutdown zone (m)	North Atlantic right whale – visual detection	at any distance	at any distance	All other Mysticetes, sperm whales, and pilot whales	1,000	1,000	Harbor porpoise	750	100	Dolphins and pilot whales	250	100	Seals	500	100	Sea Turtles	1,000	100	Construction
Species	Clearance zone (m)	Shutdown zone (m)																							
North Atlantic right whale – visual detection	at any distance	at any distance																							
All other Mysticetes, sperm whales, and pilot whales	1,000	1,000																							
Harbor porpoise	750	100																							
Dolphins and pilot whales	250	100																							
Seals	500	100																							
Sea Turtles	1,000	100																							
28	Trenchless Installation of Export Cable	Clearance and shutdown zones for vibratory pile driving during trenchless installations	<p><b>Clearance and shutdown zones during vibratory pile driving of cofferdams</b></p> <p>Table 6. Clearance and Shutdown Zones for (Vibratory Pile Driving for Cofferdam Installation)</p> <table border="1"> <thead> <tr> <th>Species</th> <th>Clearance zone (m)</th> <th>Shutdown zone (m)</th> </tr> </thead> <tbody> <tr> <td>North Atlantic right whale – visual detection</td> <td>at any distance</td> <td>at any distance</td> </tr> <tr> <td>All other Mysticetes, sperm whales, and pilot whales</td> <td>1,000</td> <td>1,000</td> </tr> <tr> <td>Harbor porpoise</td> <td>250</td> <td>100</td> </tr> <tr> <td>Dolphins</td> <td>250</td> <td>100</td> </tr> <tr> <td>Seals</td> <td>250</td> <td>100</td> </tr> <tr> <td>Sea Turtles</td> <td>1,000</td> <td>100</td> </tr> </tbody> </table> <p>Notes: In general, if the modeled PTS distance was less than 100 m, the clearance zone was set at 250 m, whereas if the modeled zone was greater than 100 m but less than 500 m, it was set at 500 m. Shutdown zones have been set at 100 m for non-mysticetes to prevent direct interactions with equipment.</p>	Species	Clearance zone (m)	Shutdown zone (m)	North Atlantic right whale – visual detection	at any distance	at any distance	All other Mysticetes, sperm whales, and pilot whales	1,000	1,000	Harbor porpoise	250	100	Dolphins	250	100	Seals	250	100	Sea Turtles	1,000	100	Construction
Species	Clearance zone (m)	Shutdown zone (m)																							
North Atlantic right whale – visual detection	at any distance	at any distance																							
All other Mysticetes, sperm whales, and pilot whales	1,000	1,000																							
Harbor porpoise	250	100																							
Dolphins	250	100																							
Seals	250	100																							
Sea Turtles	1,000	100																							
29	Trenchless Installation of Export Cable	Pre-start clearance for pile driving	<ul style="list-style-type: none"> <li>A 30-minute pre-start clearance period will be implemented prior to impact pile driving of goal post piles or vibratory piling of the temporary cofferdam. During this period, the clearance zone and surrounding waters out the maximum visual extent will be continuously monitored.</li> <li>The ESA-listed large whale shutdown zone will be fully visible for at least 30 minutes prior to commencing piling.</li> <li>If a marine mammal or sea turtle is observed entering or within the relevant clearance zones prior to the initiation of pile driving activity, pile driving activity will be delayed and will not begin until either the marine mammal(s) or sea turtle(s) has voluntarily left the respective and been visually confirmed beyond that clearance zone, or when the additional time period has elapsed with no further sighting or acoustic detection (i.e., 15 minutes for small odontocetes and 30 minutes for all other marine mammals and sea turtles).</li> </ul>	Construction																					

	Activity	Measure	Description	Project Phase
30	Trenchless Installation of Export Cable	Soft-start (ramp up) for impact pile driving (goal post piles) <sup>23</sup>	<ul style="list-style-type: none"> <li>A soft-start will occur at the beginning of the impact pile driving of each goal post and at any time following the cessation of impact pile driving of 30 minutes or longer</li> <li>The soft-start requires an initial 30 minutes using a reduced hammer energy for pile driving. An Operating Procedure will be developed to document the soft-start process incorporating final project design including specific hammer energies.</li> <li>Soft-start procedure will not begin until the clearance zones have been cleared by the visual PSOs.</li> <li>If a marine mammal is detected within or about to enter the applicable clearance zone, prior to or during the soft-start procedure, pile driving will be delayed until the animal has been observed exiting the shutdown zone or until an additional time period has elapsed with no further sighting (i.e., 15 minutes for small odontocetes and 30 minutes for all other marine mammal species and sea turtles).</li> <li>Soft-starts are not feasible for vibratory pile driving and will not be implement for vibratory piling. All remaining pre-start clearance protocols will be followed prior to initiating vibratory piling</li> </ul>	Construction
31	Trenchless Installation of Export Cable	Shutdowns	<ul style="list-style-type: none"> <li>If a marine mammal or sea turtle is detected entering or within the respective shutdown zones after pile driving has commenced, an immediate shutdown of pile driving will be implemented when practicable as determined by the lead engineer on duty who will determine if a shutdown is safe and practicable.</li> <li>If shutdown is called for but it is determined that shutdown is not feasible due to risk of injury or loss of life, there will be a reduction of hammer energy</li> <li>Following shutdown, pile driving will only be initiated once the animal has been observed exiting its respective clearance zone within 30 minutes of the shutdown, or if an additional time period has elapsed with no further sightings (i.e., 15 minutes for small odontocetes, 30 minutes for all other marine mammal species, and 30 minutes for sea turtles).</li> <li>The shutdown zone and clearance zone will be continually monitored by PSOs and PAM operators during any pauses in pile driving.</li> <li>If pile driving shuts down for reasons other than mitigation (e.g., mechanical difficulty) for periods less than 30 minutes, pile driving may restart without soft-start if PSOs have maintained constant observations and no detections of any marine mammal or sea turtles in the clearance zone have occurred.</li> </ul>	Construction

<sup>23</sup> Since submission of the BA, Dominion Energy has proposed, and NMFS OPR Permits Division has accepted, alternative soft-start text for trenchless installation. Below is the language from the proposed LOA: “Dominion Energy must utilize a soft-start protocol for impact pile driving of goal post pipe piles. Soft start requires contractors to provide an initial set of three strikes at reduced energy, followed by a 30-second waiting period, then two subsequent reduced-energy strike sets. Soft-start will be required at the beginning of the installation procedure for each goal post pipe pile and at any time following a cessation of impact pile driving of 30 minutes or longer.”

	Activity	Measure	Description	Project Phase
32	Trenchless Installation of Export Cable	Post-impact piling monitoring	PSOs will continue to survey the clearance and shutdown zones and surrounding waters throughout the duration of pile installation and for a minimum of 30 minutes after piling has been completed.	Construction
33	HRG Surveys	Daytime visual monitoring	<ul style="list-style-type: none"> <li>During daylight hours, one PSO will be on active duty and PSOs will rotate in shifts of one on and three off.</li> <li>PSOs will monitor the clearance and shutdown zones beginning 30 minutes before HRG equipment operation begins, throughout the survey operation, and 30 minutes after the end of the operation of active sources below 180 kHz.</li> <li>Applicant will follow all NMFS LOA requirements and BOEM PDC/BMPs for HRG surveys. If conflicting requirements are presented, the most protective measures will be followed.</li> </ul>	Construction, O&M
34		Visual monitoring during low visibility conditions, including nighttime.	<ul style="list-style-type: none"> <li>PSOs will work in shifts such that PSOs are working pairs during nighttime HRG survey operations.</li> <li>PSOs will use night vision equipment (e.g., night vision goggles with thermal clip-ons), infrared technology, and PAM.</li> <li>The PAM system will consist of an array of hydrophones with three broadband and three low-frequency hydrophones.</li> <li>The PAM operator(s) will monitor the hydrophone signals in real time both aurally (using headphones) and visually (via the monitor screen displays).</li> </ul>	Construction, O&M
35	HRG Surveys	Clearance and shutdown zones	<p>The following clearance and shutdown zones will be implemented during HRG surveys:</p> <ul style="list-style-type: none"> <li>1,640-ft (500-m) clearance and shutdown zone for NARW.</li> <li>1,640-ft (500-m) clearance zone and shutdown zone for all ESA-listed marine mammal species.</li> <li>328-ft (100-m) clearance and shutdown zone for all other marine mammal except delphinids from the genera <i>Delphinus</i>, <i>Lagenorhynchus</i>, <i>Stenella</i> or <i>Tursiops</i>; and seals.</li> <li>3,280-ft (500-m) clearance zone and a 328-ft (100-m) shutdown zone for sea turtles.</li> </ul>	Construction, O&M
36	HRG Surveys	Pre-start clearance	<ul style="list-style-type: none"> <li>PSOs will implement a 30-minute clearance period of the applicable clearance prior to the initiation of soft-start using the appropriate visual technology for the duration.</li> <li>Soft-start of HRG survey equipment may not be initiated if any ESA-listed animal is within its respective clearance zone.</li> <li>If an animal is observed within its respective clearance zone, soft-start will be delayed until the animal is observed exiting the zone or an additional time has elapsed with no further sighting (i.e., 15 minutes for small odontocetes, 30 minutes for all other marine mammals, and 30 minutes for sea turtles).</li> </ul>	Construction, O&M
37	HRG Surveys	Soft-start of HRG survey equipment	Where technically feasible, HRG equipment will be activated starting with the smallest acoustic source at its lowest practical power output appropriate for the survey, and then gradually turned up and other sources added in such a way that the source level increases gradually.	Construction, O&M

	Activity	Measure	Description	Project Phase
38	HRG Surveys	Shutdowns	<ul style="list-style-type: none"> <li>If an animal is observed within its respective shutdown zone (described above) an immediate shutdown of HRG equipment will be required.</li> <li>The clearance zone must be continually monitored by PSOs during any pauses in HRG survey activity, activities will be delayed until the animal(s) has been observed leaving the clearance zone within 30 minutes of the shutdown, or after an additional time period has elapsed with no further sightings (i.e., 15 minutes for small odontocetes, 30 minutes for all other marine mammals, and 30 minutes for sea turtles).</li> </ul>	Construction, O&M
39	All Activities: Reporting	PSO Reporting	<ul style="list-style-type: none"> <li>All PSOs will use a standardized data entry format.</li> <li>Operations, monitoring conditions, observation effort, all marine mammal, sea turtle, and ESA-listed fish detections, and any mitigation actions will be recorded.</li> </ul>	Construction
40	All Activities: Reporting	Injured protected species reporting	Any potential takes, strikes, stranded, entangled, or dead/injured protected species regardless of cause, will be reported by the vessel captain or the PSO onboard to the Greater Atlantic (Northeast) Region Marine Mammal and Sea Turtle Stranding and Entanglement Hotline (866-755-NOAA [6622]) within 24 hours of a sighting. In addition, if the injury or death was caused by a collision with a Project-related vessel, Dominion Energy will ensure that NMFS is notified of the strike within 24 hours. The notification will include date and location (latitude and longitude) of the strike, name of the vessel involved, and the species identification or a description of the animal, if possible. If the Project activity is responsible for the injury or death, Dominion Energy will supply a vessel to assist in any salvage effort as requested by NMFS.	Construction, O&M, decommissioning
41	All Activities: Reporting	Reporting observed impacts on species	<ul style="list-style-type: none"> <li>PSOs/PAM operators will report any observations concerning impacts on marine mammals, sea turtles, and ESA-listed fish to NMFS within 48 hours.</li> <li>BOEM and NMFS will be notified within 24 hours if any evidence of a fish kill during construction activity is observed.</li> </ul>	Construction, O&M, decommissioning
42	All Activities: Reporting	Report of activities and observations	Dominion Energy will provide NMFS with a report within 90 calendar days following the completion of construction and HRG surveys, including a summary of the activities and an estimate of the number of marine mammals taken.	Construction, O&M, decommissioning

	Activity	Measure	Description	Project Phase
42	All Activities: Reporting	Report information	<ul style="list-style-type: none"> <li>Data on all marine mammal, sea turtle, and ESA-listed fish observations will be recorded and based on standards of protected species observer collection data by the PSOs. This information will include dates, times, and locations of survey operations; time of observation, location and weather; details of animal sightings (e.g., species, numbers, behavior); and details of any observed taking (e.g., behavioral disturbances or injury).</li> <li>A quality assured/quality controlled database of all sightings and associated details (e.g., distance from vessel, behavior, species, group size/composition) within and outside of the designated shutdown zones, monitoring effort, environmental conditions, and Project-related activity will be provided after field operations and reporting are complete. This database will undergo thorough quality checks and include all variables required by the NMFS-issued Incidental Take Authorization and BOEM ROD requirements, and ESA consultation and will be included for the Final Technical Report due to BOEM and NMFS.</li> <li>During construction, weekly reports briefly summarizing sightings, detections and activities will be provided to NMFS and BOEM on the Wednesday following a Sunday-Saturday period.</li> <li>Final reports will follow a standardized format for PSO reporting from activities requiring protected species mitigation and monitoring</li> <li>An annual report summarizing the prior year's activities will be provided to NMFS and to BOEM on April 1 every calendar year summarizing the prior year's activities.</li> </ul>	Construction, O&M, decommissioning

BMP = best management practice; BOEM = Bureau of Ocean Energy Management; CVOW-C = Coastal Virginia Offshore Wind Commercial; DMA = Dynamic Management Area; ESA = Endangered Species Act; HRG = high-resolution geophysical; MMPA = Marine Mammal Protection Act; NARW = North Atlantic right whale; NMFS = National Marine Fisheries Service; NOAA = National Oceanic and Atmospheric Administration; O&M = operations and maintenance; PAM = passive acoustic monitoring; PDC = project design criteria; PSO = protected species observer; ROD = Record of Decision; SMA = Seasonal Management Area; SFV = sound field verification; VHF = very high-frequency.  
 Source: Dominion Energy 2022; Tetra Tech (2022b).

**15.2 Copy of Table 1-8 in BOEM’s BA: Additional proposed mitigation, monitoring, and reporting measures proposed by BOEM**

No.	Activity	Measure	Description	Project Phase	Expected Effects
1	General	Vessel strike avoidance procedures	<p>Applicant proposed measures plus:</p> <ul style="list-style-type: none"> <li>• As part of vessel strike avoidance, a training program will be implemented. The training program will be provided to NMFS for review and approval prior to the start of surveys. Confirmation of the training and understanding of the requirements will be documented on a training course log sheet. Signing the log sheet will certify that the crew members understand and will comply with the necessary requirements throughout the survey event.</li> <li>• Vessel operators and crew must maintain a vigilant watch for marine mammals and sea turtles by slowing down or stopping their vessels to avoid striking these protected species. Vessel crew members responsible for navigation duties will receive site-specific training on marine mammal sighting/reporting and vessel strike avoidance measures. Vessel strike avoidance measures will include, but are not limited to the following, except under extraordinary circumstances when complying with these measures would put the safety of the vessel or the crew at risk: <ul style="list-style-type: none"> <li>○ If underway, vessels must steer a course away from any sighted NARW at 10 knots (18.5 km/hr) or less until the 1,640 ft (500 m) minimum separation distance has been established. If a NARW is sighted in a vessel's path, or within 330 ft (100 m) of an underway vessel, the underway vessel must reduce speed and shift the engine to neutral. Engines will not be engaged until the NARW has moved outside of the vessel's path and beyond 330 ft (100 m). If stationary, the vessel must not engage engines until the NARW has moved beyond 330 ft (100 m);</li> <li>○ All vessels will maintain a separation distance of 330 ft (100 m) or greater of any sighted whales. If sighted, the vessel underway must reduce speed and shift the engine to neutral and must not engage the engines until the whale has moved outside the vessel's path and beyond 330 ft (100 m). If a survey vessel is stationary, the vessel will not engage engines until the whale has moved out of the vessel's path and beyond 330 ft (100 m);</li> <li>○ Vessel operators will use all available sources of information of NARW presence, including daily monitoring of the Right Whale Sightings Advisory System, WhaleAlert app, and monitoring of USCG VHF Channel 16 to receive notifications of right whale detections, SMAs, DMAs, and Slow Zones to plan vessel routes to minimize the potential for co-occurrence with right whales.</li> </ul> </li> </ul>	All phases	<b>Maintains safe operating distances</b>
2	General	Incorporate LOA requirements	The measures required by the final MMPA LOA would be incorporated into COP approval, and BOEM, BSEE, or both would monitor compliance with these measures.	Years 1–5 construction	Incorporation of mitigation measures designed to reduce effects on listed and non-listed marine mammals

No.	Activity	Measure	Description	Project Phase	Expected Effects
3	General	BOEM PDCs and BMPs	<p>BOEM will require Dominion Energy comply with all the Project Design Criteria and BMP for Protected Species at <a href="https://www.boem.gov/sites/default/files/documents//PDCs%20and%20BMPs%20for%20Atlantic%20Data%20Collection%2011222021.pdf">https://www.boem.gov/sites/default/files/documents//PDCs%20and%20BMPs%20for%20Atlantic%20Data%20Collection%2011222021.pdf</a>.</p> <p>that implement the integrated requirements for threatened and endangered species resulting from the June 29, 2021, programmatic consultation under the ESA, revised September 1, 2021. This requirement also applies to non-ESA-listed marine mammals that are found in that document. Consultation conditions occurring in State waters outside of BOEM jurisdiction may apply to co-action agencies issuing permits and authorizations under this consultation</p>	All phases	Ensure the PDE includes preventative mitigation measures to avoid potential effects on ESA-listed species, in addition to external mitigation implemented during Project activities
4	General	Look out for sea turtles and reporting	<p>a. For all vessels operating north of the Virginia/North Carolina border, between June 1 and November 30, Dominion Energy would have a trained lookout posted on all vessel transits during all phases of the project to observe for sea turtles. The trained lookout would communicate any sightings, in real time, to the captain so that the requirements in I below can be implemented.</p> <p>b. For all vessels operating south of the Virginia/North Carolina border, year-round, Dominion Energy would have a trained lookout posted on all vessel transits during all phases of the project to observe for sea turtles. The trained lookout would communicate any sightings, in real time, to the captain so that the requirements below can be implemented. This requirement is in place year-round for any vessels transiting south of Virginia, as sea turtles are present year-round in those waters.</p> <p>c. The trained lookout would monitor <a href="https://seaturtlesightings.org/">https://seaturtlesightings.org/</a> prior to each trip and report any observations of sea turtles in the vicinity of the planned transit to all vessel operators/captains and lookouts on duty that day.</p>	All phases	Minimize risk of vessel strikes to sea turtles

No.	Activity	Measure	Description	Project Phase	Expected Effects
4 (cont'd)	General	Look out for sea turtles and reporting	<p>d. If a sea turtle is sighted within 330 ft (100 m) or less of the operating vessel's forward path, the vessel operator would slow down to 4 knots (unless unsafe to do so) and then proceed away from the turtle at a speed of 4 knots or less until there is a separation distance of at least 330 ft (100 m), at which time the vessel may resume normal operations. If a sea turtle is sighted within 164 ft (50 m) of the forward path of the operating vessel, the vessel operator would shift to neutral when safe to do so and then proceed away from the turtle at a speed of 4 knots. The vessel may resume normal operations once it has passed the turtle.</p> <p>e. Vessel captains/operators would avoid transiting through areas of visible jellyfish aggregations or floating sargassum lines or mats. In the event that operational safety prevents avoidance of such areas, vessels would slow to 4 knots while transiting through such areas.</p> <p>f. All vessel crew members would be briefed in the identification of sea turtles and in regulations and best practices for avoiding vessel collisions. Reference materials would be available aboard all project vessels for identification of sea turtles. The expectation and process for reporting of sea turtles (including live, entangled, and dead individuals) would be clearly communicated and posted in highly visible locations aboard all project vessels, so that there is an expectation for reporting to the designated vessel contact (such as the lookout or the vessel captain), as well as a communication channel and process for crew members to do so.</p> <p>g. The only exception is when the safety of the vessel or crew necessitates deviation from these requirements on an emergency basis. If any such incidents occur, they would be reported to NMFS within 24 hours.</p> <p>h. If a vessel is carrying a PSO or trained lookout for the purposes of maintaining watch for NARWs, an additional lookout is not required and this PSO or trained lookout would maintain watch for marine mammals and sea turtles.</p> <p>Vessel transits to and from the Offshore Project area, that require PSOs will maintain a speed commensurate with weather conditions and effectively detecting sea turtles prior to reaching the 330 ft (100 m) avoidance measure.</p>	All phases	Minimize risk of vessel strikes to sea turtles



No.	Activity	Measure	Description	Project Phase	Expected Effects
5	General	Marine debris awareness training	<p>Dominion Energy would ensure that vessel operators, employees, and contractors engaged in offshore activities pursuant to the approved COP complete marine trash and debris awareness training annually. The training consists of two parts: (1) viewing a marine trash and debris training video or slide show (described below); and (2) receiving an explanation from management personnel that emphasizes their commitment to the requirements. The marine trash and debris training videos, training slide packs, and other marine debris related educational material may be obtained at <a href="https://www.bsee.gov/debris">https://www.bsee.gov/debris</a> or by contacting BSEE. The training videos, slides, and related material may be downloaded directly from the website. Operators engaged in marine survey activities would continue to develop and use a marine trash and debris awareness training and certification process that reasonably assures that their employees and contractors are in fact trained. The training process would include the following elements:</p> <ul style="list-style-type: none"> <li>• Viewing of either a video or slide show by the personnel specified above;</li> <li>• An explanation from management personnel that emphasizes their commitment to the requirements;</li> <li>• Attendance measures (initial and annual); and</li> <li>• Record keeping and the availability of records for inspection by DOI.</li> </ul> <p>By January 31 of each year, Dominion Energy would submit to DOI an annual report that describes its marine trash and debris awareness training process and certifies that the training process has been followed for the previous calendar year. Dominion Energy would send the reports via email to BOEM (at <a href="mailto:renewable_reporting@boem.gov">renewable_reporting@boem.gov</a>) and to <a href="mailto:BSEE(at)marinedebris@bsee.gov">BSEE (at marinedebris@bsee.gov)</a>.</p>	All phases	Decrease the loss of marine debris, which may represent entanglement and/ or ingestions risk
6	General	BOEM/ NMFS meeting requirements for sea turtle take documentation	To facilitate monitoring of the incidental take exemption for sea turtles, through the first year of operations, BOEM and NMFS would meet twice annually to review sea turtle observation records. These meetings/conference calls would be bi-annually) and would use the best available information on sea turtle presence, distribution, and abundance, project vessel activity, and observations to estimate the total number of sea turtle vessel strikes in the action area that are attributable to project operations. These meetings would continue on an annual basis following year one of operations. Upon mutual agreement of NMFS and BOEM, the frequency of these meetings can be changed.	Construction and year 1 of operations	Establish process for monitoring of IT exemption for sea turtles
7	General	Data Collection BA BMPs	BOEM would ensure that all PDC and BMPs incorporated in the Atlantic Data Collection consultation for Offshore Wind Activities (June 2021) shall be applied to activities associated with the construction, maintenance and operations of the Dominion Energy project as applicable.	All phases	Incorporate previously determined best management practices to reduce the likelihood of take of listed species during surveys, vessel operations, and maintenance in the Atlantic OCS
8	General	BOEM COP PDCs and BMPs	Use standard underwater cables that have electrical shielding to control the intensity of electromagnetic fields (EMF).	Construction, O&M	Decrease area of EMF effects on marine mammals, sea turtles, and ESA-listed fish.

No.	Activity	Measure	Description	Project Phase	Expected Effects
			<p>Lessees and grantees should evaluate marine mammal use of the proposed Action Area and should design the project to minimize and mitigate the potential for mortality or disturbance. The amount and extent of ecological baseline data required should be determined on a project basis.</p>	Pre-Construction	Avoid effects with early planning.
			<p>Vessels related to project planning, construction, and operation should travel at reduced speeds when assemblages of cetaceans are observed. Vessels also should maintain a reasonable distance from whales, small cetaceans, and sea turtles, and these should be determined during site-specific consultations.</p>	All phases	Minimize the potential for ESA-listed species strikes from vessels
			<p>Lessees and grantees should minimize potential vessel effects on marine mammals and sea turtles by having project-related vessels follow the NMFS Regional Viewing Guidelines while in transit. Operators should undergo training on applicable vessel guidelines.</p>	All phases	Minimize the potential for ESA-listed species strikes from vessels with ESA-listed species.
			<p>Lessees and grantees should take efforts to minimize disruption and disturbance to marine life from sound emissions, such as pile driving, during construction activities.</p>	All phases	minimize the potential and severity of noise effects
			<p>Lessees and grantees should avoid and minimize effects on marine species and habitats in the Action Area by posting a qualified observer on site during construction activities. This observer should be approved by BOEM and NMFS.</p>	Construction	ensure the effectiveness of mitigation and monitoring measures
9	General	Periodic Underwater Surveys, Reporting of Monofilament and Other Fishing Gear Around WTG Foundations	<p>Dominion Energy must monitor indirect effects associated with charter and recreational fishing gear lost from expected increases in fishing around WTG foundations by surveying at least 10 of the WTGs located closest to shore in the Dominion Energy Lease Area (OCS-A 0483) annually. Survey design and effort may be modified with review and concurrence by DOI. Dominion Energy may conduct surveys by remotely operated vehicles, divers, or other means to determine the frequency and locations of marine debris. Dominion Energy must report the results of the surveys to BOEM (at <a href="mailto:renewable_reporting@boem.gov">renewable_reporting@boem.gov</a>) and BSEE (at <a href="mailto:marinedebris@bsee.gov">marinedebris@bsee.gov</a>) in an annual report, submitted by April 30, for the preceding calendar year. Annual reports must be submitted in Word format.</p> <p>Photographic and videographic materials must be provided on a portable drive in a lossless format such as TIFF or Motion JPEG 2000. Annual reports must include survey reports that include: the survey date; contact information of the operator; the location and pile identification number; photographic, video documentation, or both of the survey and debris encountered; any animals sighted; and the disposition of any located debris (i.e., removed or left in place). Annual reports must also include claim data attributable to the Project from Dominion Energy corporate gear loss compensation policy and procedures. Required data and reports may be archived, analyzed, published, and disseminated by BOEM.</p>	Operations	Establish requirement for monitoring and reporting of lost monofilament and other fishing gear around WTGs
10	Foundation Installation	PAM Plan	<p>BOEM and USACE would ensure that Dominion Energy prepares a PAM Plan that describes all proposed equipment, deployment locations, detection review methodology and other procedures, and protocols related to the proposed uses of PAM for mitigation and long-term monitoring. This plan would be submitted to NMFS and BOEM for review and concurrence at least 120 days prior to the planned start of activities requiring PAM.</p>	Construction and post-construction monitoring	Ensure the efficacy of PAM placement for appropriate monitoring

No.	Activity	Measure	Description	Project Phase	Expected Effects
11	Foundation Installation	Pile driving monitoring plan	BOEM would ensure that Dominion Energy prepare and submit a Pile Driving Monitoring Plan to BOEM, BSEE, and NMFS for review and concurrence at least 90 days before start of pile driving. The plan would detail all plans and procedures for sound attenuation as well as for monitoring ESA-listed whales and sea turtles during all impact and vibratory pile driving. The plan would also describe how BOEM and Dominion Energy would determine the number of whales exposed to noise above the Level B harassment threshold during pile driving with the vibratory hammer to install the cofferdam at the sea to shore transition. Dominion Energy would obtain NMFS' concurrence with this plan prior to starting any pile driving.	Construction	Ensure adequate monitoring and mitigation is in place during pile driving
12	Foundation Installation	PSO Coverage	<p>BOEM and USACE would ensure that PSO coverage is sufficient to reliably detect marine mammals and sea turtles at the surface in the identified clearance and shutdown zones to execute any pile driving delays or shutdown requirements. This will include a PSO/ PAM team on the construction vessel and two additional PSO vessels each with a visual monitoring team. The following equipment and personnel will be on each associated vessel:</p> <p><b>Construction Vessel:</b></p> <ul style="list-style-type: none"> <li>• 2, visual PSOs on watch</li> <li>• 2, (7x) or (10x) reticle binoculars calibrated for observer height off the water.</li> <li>• 2 (25x or similar) mounted "big eye" binoculars if vessel is deemed appropriate to provide a platform in which use of the big eye binoculars would be effective.</li> <li>• 1, PAM operator on duty</li> <li>• 1, mounted thermal/IR camera system</li> <li>• 2, (25x or similar) "big eye" binoculars mounted 180 deg apart</li> <li>• 1, monitoring station for real-time PAM system</li> <li>• 2, handheld or wearable NVDs with IR spotlights</li> <li>• 1, Data collection software system</li> <li>• 2, PSO-dedicated VHF radios</li> <li>• 1, digital single lens reflex camera equipped with a 300-mm lens</li> </ul> <p><b>Each Additional PSO Vessels (2):</b></p> <ul style="list-style-type: none"> <li>• 2, visual PSOs on watch</li> <li>• 2, (7x) or (10x) reticle binoculars calibrated for observer height off the water.</li> <li>• 1, (25x or similar) mounted "big eye" binoculars if vessel is deemed appropriate to provide a platform in which use of the big eye binoculars would be effective.</li> <li>• 1, mounted thermal/IR camera system</li> <li>• 1, handheld or wearable NVD with IR spotlight</li> <li>• 1, Data collection software system</li> <li>• 2, PSO-dedicated VHF radios</li> <li>• 1, digital single lens reflex camera equipped with a 300-mm lens</li> </ul> <p>If, at any point prior to or during construction, the PSO coverage that is included as part of the Proposed Action is determined not to be sufficient to reliably detect ESA-listed whales and sea turtles within the clearance and shutdown zones, additional PSOs, platforms, or both would be deployed. Determinations prior to construction would be based on review of the Pile Driving Monitoring Plan. Determinations during construction would be based on review of the weekly pile driving reports and other information, as appropriate.</p>	Construction	Ensure adequate monitoring of zones

<p>13</p>	<p>Foundation Installation</p>	<p>Sound Field Verification Plan</p>	<p>BOEM would require Dominion Energy to develop an operational sound field verification plan to determine the operational noises emitted from the Offshore Project area.</p> <p>The Lessee must submit the SFV Plan to BOEM, BSEE, and NMFS GARFO at least 180 days before impact pile driving is planned to begin. BOEM, BSEE, and NMFS GARFO will review the plan and will provide comments within 45 days of receipt of the plan. NMFS GARFO’s comments to BOEM, BSEE, and the Lessee will include a determination as to whether the plan is consistent with the requirements outlined in the Biological Opinion and its ITS. If the plan is determined to be inconsistent with these requirements, the Lessee must resubmit a modified plan that addresses the identified issues at least 15 days before the start of the associated activity; at that time, BOEM, BSEE and NMFS will discuss a timeline for review and approval of the modified plan. Under the terms of the NMFS Biological Opinion, the Lessee must obtain BOEM, BSEE, and NMFS GARFO’s concurrence with this plan prior to the start of pile driving activities. The plan must describe how the Lessee will ensure that the first three monopile and pin pile installation sites selected for SFV are representative of the rest of the monopile and pin pile installation sites. In the case that these sites are not determined to be representative of all other monopile and pin pile installation sites, the Lessee must include information on how additional sites will be selected for SFV. The plan must also include methodology for collecting, analyzing, and preparing SFV data for submission to NMFS GARFO. The Lessee’s plan must describe how the effectiveness of the sound attenuation methodology will be evaluated based on the results. The Lessee must also provide, as soon as they are available, but no later than 48 hours after each installation, the initial results of the SFV measurements to BOEM, BSEE, and NMFS GARFO in an interim report after each monopile for the first 3 piles and pin pile installation for the first full jacket foundation (4 pin piles). If any interim SFV report submitted for any of the first 3 monopiles indicates the sound fields exceed the modeled distances to any protected species injury or behavioral harassment/disturbance thresholds (as modeled assuming 10 decibel attenuation), the Lessee must carry out SFV for the next 3 monopiles and provide a SFV report to BOEM, BSEE, and NMFS GARFO within 48 hours after each foundation is installed. If any interim SFV report submitted for the first full jacket foundation indicates the sound fields exceed the modeled distances to any protected species injury or behavioral harassment/disturbance thresholds (as modeled assuming 10 decibel attenuation), the Lessee must carry out SFV for the next full jacket foundation (i.e., all 4 pin piles) and provide a SFV report to BOEM, BSEE, and NMFS GARFO within 48 hours after the foundation is installed. After the first 6 monopiles and/or the first two full jacket foundations (i.e., 8 pin piles), BOEM, BSEE, or NMFS GARFO may require the Lessee to carry out additional SFV and provide additional interim SFV reports to BOEM, BSEE, and NMFS GARFO if the measured sound fields continue to exceed the modeled results. These requirements are in addition to the requirement for the Lessee to implement additional sound attenuation measures and/or adjustments to clearance and shutdown zones if sound fields exceed the modeled distances to any protected species injury or behavioral harassment/disturbance thresholds (as modeled assuming 10 decibel attenuation).</p> <ul style="list-style-type: none"> <li>• The plan will include measurement procedures and results reporting that meet ISO standard 18406:2017 (Underwater acoustics – Measurement of radiated underwater sound from percussive pile driving)</li> </ul>	<p>Operations</p>	<p>Establish requirement for operational noise monitoring</p>
-----------	--------------------------------	--------------------------------------	---	-------------------	---

No.	Activity	Measure	Description	Project Phase	Expected Effects
14	Foundation Installation	Sound field verification	Applicant proposed measures plus: <ul style="list-style-type: none"> <li>BOEM and USACE would ensure that if the clearance, shutdown zones, or both are expanded due to the verification of sound fields from Project activities, PSO coverage is sufficient to reliably monitor the expanded clearance, shutdown zones, or both. Additional observers would be deployed on additional platforms for every 4,921 ft (1,500 m) that a clearance or shutdown zone is expanded beyond the distances modeled prior to verification.</li> </ul>	Construction	Ensure adequate monitoring of clearance zones
15	Foundation Installation	Adaptive shutdown zones	BOEM and USACE may consider reductions in the shutdown zones for sei, fin or sperm whales based on sound field verification of a minimum of 3 piles; however, BOEM/USACE would ensure that the shutdown zone for sei whales, fin whales, blue whales, and sperm whales is not reduced to less than 3,280 ft (1,000 m), or 1,640 ft (500 m) for sea turtles. No reductions in the clearance or shutdown zones for NARWs would be considered regardless of the results of sound field verification of a minimum of three piles.	Construction	Ensure that shut down zones are sufficiently conservative
16	Foundation Installation and Trenchless Installation of Export Cable	Minimum visibility requirement	<ul style="list-style-type: none"> <li>In order to commence pile driving at foundations, PSOs must be able to visually monitor a 5,741-ft (1,750-m)<sup>24</sup> radius from their observation points for at least 60 minutes immediately prior to piling commencement.</li> <li>In order to commence pile driving at trenchless installation sites, PSOs must be able to visually monitor a 3,280-ft (1,000-m) from their observation points for at least 30 minutes immediately prior to piling commencement.</li> </ul> Acceptable visibility will be determined by the Lead PSO.	Construction	Ensure adequate monitoring of zones
17	Foundation Installation and Trenchless	Monitoring zone for sea turtles	Applicant proposed measures plus: <ul style="list-style-type: none"> <li>BOEM and USACE would ensure that Dominion Energy monitors the full extent of the area where noise would exceed the root-mean-square sound pressure level (SPL) 175 dB re 1 µPa behavioral disturbance threshold for turtles for the full duration of all pile driving activities and for 30 minutes following the cessation of pile driving activities and record all observations in order to ensure that all take that occurs is documented.</li> </ul>	Construction	Ensure accurate monitoring of sea turtle take

<sup>24</sup> The proposed LOA updated the visual monitoring radius to 2,000 m, and this distance is anticipated to be carried through to the final LOA.

No.	Activity	Measure	Description	Project Phase	Expected Effects
18	Foundation installation and Trenchless Installations of Export Cable	Alternative Monitoring Plan (AMP) for Pile Driving	<p>Dominion Energy must not conduct pile driving operations at any time when lighting or weather conditions (e.g., darkness, rain, fog, sea state) prevent visual monitoring of the full extent of the clearance and shutdown zones.</p> <ul style="list-style-type: none"> <li>• Dominion Energy must submit an AMP to BOEM and NMFS for review and approval at least 6 months prior to the planned start of pile-driving. This plan may include deploying additional observers, alternative monitoring technologies such as night vision, thermal, and infrared technologies, or use of PAM and must demonstrate the ability and effectiveness to maintain all clearance and shutdown zones during daytime as outlined below in Part 1 and nighttime as outlined in Part 2 to BOEM's and NMFS's satisfaction.</li> <li>• The AMP must include two stand-alone components as described below:                             <ul style="list-style-type: none"> <li>○ Part 1 – Daytime when lighting or weather (e.g., fog, rain, sea state) conditions prevent visual monitoring of the full extent of the clearance and shutdown zones. Daytime being defined as 1 hour after civil sunrise to 1.5 hours before civil sunset.</li> <li>○ Part 2 – Nighttime inclusive of weather conditions (e.g., fog, rain, sea state). Nighttime being defined as 1.5 hours before civil sunset to 1 hour after civil sunrise.</li> </ul> </li> <li>• If a protected marine mammal or sea turtle is observed entering or found within the shutdown zones after impact pile-driving has commenced, Dominion Energy would follow the shutdown procedures outlined in Table 1-7 of this Biological Assessment. Dominion Energy would notify BOEM and NMFS of any shutdown occurrence during piling driving operations with 24 hours of the occurrence unless otherwise authorized by BOEM and NMFS.</li> </ul>	Construction	Establish requirement for nighttime impact pile driving approval

No.	Activity	Measure	Description	Project Phase	Expected Effects
18 (cont'd)	Foundation installation and Trenchless Installation of Export Cable	Alternative Monitoring Plan (AMP) for Pile Driving	<ul style="list-style-type: none"> <li>• The AMP should include, but is not limited to the following information:                             <ul style="list-style-type: none"> <li>○ Identification of night vision devices (e.g., mounted thermal/infrared camera systems, hand-held or wearable NVDs, infrared spotlights), if proposed for use to detect protected marine mammal and sea turtle species.</li> <li>○ The AMP must demonstrate (through empirical evidence) the capability of the proposed monitoring methodology to detect marine mammals and sea turtles within the full extent of the established clearance and shutdown zones (i.e., species can be detected at the same distances and with similar confidence) with the same effectiveness as daytime visual monitoring (i.e., same detection probability). Only devices and methods demonstrated as being capable of detecting marine mammals and sea turtles to the maximum extent of the clearance and shutdown zones will be acceptable.</li> <li>○ Evidence and discussion of the efficacy (range and accuracy) of each device proposed for low visibility monitoring must include an assessment of the results of field studies (e.g., Thayer Mahan demonstration), as well as supporting documentation regarding the efficacy of all proposed alternative monitoring methods (e.g., best scientific data available).</li> <li>○ Reporting procedures, contacts and timeframes.</li> </ul> </li> </ul> <p>BOEM may request additional information, when appropriate, to assess the efficacy of the AMP.</p>		
19	Fisheries Sampling	Sampling gear	All sampling gear would be hauled at least once every 30 days, and all gear would be removed from the water and stored on land between survey seasons to minimize risk of entanglement.	All fisheries surveys	Minimize risk of entanglement
20	Fisheries Sampling	Gear identification	To facilitate identification of gear on any entangled animals, all trap/pot gear used in the surveys would be uniquely marked to distinguish it from other commercial or recreational gear. Using black and yellow striped duct tape, place a 3-ft-long mark within 2 fathoms of a buoy. In addition, using black and white paint or duct tape, place 3 additional marks on the top, middle and bottom of the line. These gear marking colors are proposed as they are not gear markings used in other fisheries and are, therefore, distinct. Any changes in marking would not be made without notification and approval from NMFS.	Pot/trap surveys	Distinguish survey gear from other commercial or recreational gear
21	Fisheries Sampling	Lost survey gear	If any survey gear is lost, all reasonable efforts that do not compromise human safety would be undertaken to recover the gear. All lost gear would be reported to NMFS ( <a href="mailto:nmfs.gar.incidental-take@noaa.gov">mailto:nmfs.gar.incidental-take@noaa.gov</a> ) within 24 hours of the documented time of missing or lost gear. This report would include information on any markings on the gear and any efforts undertaken or planned to recover the gear.	All fisheries surveys	Promote recovery of lost gear

No.	Activity	Measure	Description	Project Phase	Expected Effects
22	Fisheries Sampling	Training	At least one of the survey staff onboard the trawl surveys <sup>25</sup> and ventless trap surveys would have completed NEFOP observer training (within the last 5 years) or other training in protected species identification and safe handling (inclusive of taking genetic samples from Atlantic sturgeon). Reference materials for identification, disentanglement, safe handling, and genetic sampling procedures would be available on board each survey vessel. BOEM would ensure that Dominion Energy prepares a training plan that addresses how this requirement would be met and that the plan is submitted to NMFS in advance of any trawl or trap surveys. This requirement is in place for any trips where gear is set or hauled.	Trawl and ventless trap surveys	Promote safe handling and release of Atlantic sturgeon
23	Fisheries Sampling	Sea turtle disentanglement	Vessels deploying fixed gear (e.g., pots/traps) would have adequate disentanglement equipment (i.e., knife and boathook) onboard. Any disentanglement would occur consistent with the Northeast Atlantic Coast STDN Disentanglement Guidelines at <a href="https://www.reginfo.gov/public/do/DownloadDocument?objectID=102486501">https://www.reginfo.gov/public/do/DownloadDocument?objectID=102486501</a> and the procedures described in “Careful Release Protocols for Sea Turtle Release with Minimal Injury” (NOAA Technical Memorandum 580; <a href="https://repository.library.noaa.gov/view/noaa/3773">https://repository.library.noaa.gov/view/noaa/3773</a> ).	Pot/trap surveys	Require disentanglement of sea turtles caught in gear
24	Fisheries Sampling	Sea turtle/ESA-fish identification and data collection	Any sea turtles or ESA-fish caught, retrieved, or both in any fisheries survey gear would first be identified to species or species group. Each ESA-listed species caught, retrieved, or both would then be properly documented using appropriate equipment and data collection forms. Biological data, samples, and tagging would occur as outlined below. Live, uninjured animals should be returned to the water as quickly as possible after completing the required handling and documentation. <ul style="list-style-type: none"> <li>a. The Sturgeon and Sea Turtle Take Standard Operating Procedures would be followed (download at: <a href="https://media.fisheries.noaa.gov/2021-11/Sturgeon-Sea-Turtle-Take-SOPs-external-11032021.pdf">https://media.fisheries.noaa.gov/2021-11/Sturgeon-Sea-Turtle-Take-SOPs-external-11032021.pdf</a> .)</li> <li>b. Survey vessels would have a passive integrated transponder (PIT) tag reader onboard capable of reading 134.2 kHz and 125 kHz encrypted tags (e.g., Biomark GPR Plus Handheld PIT Tag Reader) and this reader be used to scan any captured sea turtles and sturgeon for tags. Any recorded tags would be recorded on the take reporting form (see below).</li> </ul>	All fisheries surveys	Require standard data collection and documentation of any sea turtle/Atlantic sturgeon caught during surveys

<sup>25</sup> No trawl surveys are part of the proposed action.



No.	Activity	Measure	Description	Project Phase	Expected Effects
24 (cont'd)	Fisheries Sampling	Sea turtle/ESA-fish identification and data collection	<p>c. Genetic samples would be taken from all captured ESA-fish (alive or dead) to allow for identification of the DPS of origin of captured individuals and tracking of the amount of incidental take. This would be done in accordance with the Procedures for Obtaining Sturgeon Fin Clips (download at: <a href="https://media.fisheries.noaa.gov/dam-migration/sturgeon_genetics_sampling_revised_june_2019.pdf">https://media.fisheries.noaa.gov/dam-migration/sturgeon_genetics_sampling_revised_june_2019.pdf</a>).</p> <ul style="list-style-type: none"> <li>o Fin clips would be sent to a NMFS approved laboratory capable of performing genetic analysis and assignment to DPS of origin. To the extent authorized by law, BOEM is responsible for the cost of the genetic analysis. Arrangements would be made for shipping and analysis in advance of submission of any samples; these arrangements would be confirmed in writing to NMFS within 60 days of the receipt of this ITS. Results of genetic analysis, including assigned DPS of origin would be submitted to NMFS within 6 months of the sample collection.</li> <li>o Subsamples of all fin clips and accompanying metadata forms would be held and submitted to a tissue repository (e.g., the Atlantic Coast Sturgeon Tissue Research Repository) on a quarterly basis. The Sturgeon Genetic Sample Submission Form is available for download at: <a href="https://media.fisheries.noaa.gov/2021-02/Sturgeon%20Genetic%20Sample%20Submission%20sheet%20for%20S7_v1.1_Form%20to%20Use.xlsx?null">https://media.fisheries.noaa.gov/2021-02/Sturgeon%20Genetic%20Sample%20Submission%20sheet%20for%20S7_v1.1_Form%20to%20Use.xlsx?null</a>.</li> </ul> <p>d. All captured sea turtles and ESA-fish would be documented with required measurements and photographs. The animal's condition and any marks or injuries would be described. This information would be entered as part of the record for each incidental take. A NMFS Take Report Form would be filled out for each individual sturgeon and sea turtle (download at: <a href="https://media.fisheries.noaa.gov/2021-07/Take%20Report%20Form%2007162021.pdf?null">https://media.fisheries.noaa.gov/2021-07/Take%20Report%20Form%2007162021.pdf?null</a>) and submitted to NMFS as described below.</p>	All fisheries surveys	Require standard data collection and documentation of any sea turtle/Atlantic sturgeon caught during surveys

No.	Activity	Measure	Description	Project Phase	Expected Effects
25	Fisheries Sampling	Sea turtle/ESA-fish handling and resuscitation guidelines	<p>Any sea turtles or ESA-fish caught and retrieved in gear used in fisheries surveys would be handled and resuscitated (if unresponsive) according to established protocols and whenever at-sea conditions are safe for those handling and resuscitating the animal(s) to do so. Specifically:</p> <ul style="list-style-type: none"> <li>e. Priority would be given to the handling and resuscitation of any sea turtles or ESA-fish that are captured in the gear being used, if conditions at sea are safe to do so. Handling times for these species should be minimized (i.e., kept to 15 minutes or less) to limit the amount of stress placed on the animals.</li> <li>f. All survey vessels would have copies of the sea turtle handling and resuscitation requirements found at 50 CFR 223.206(d)(1) prior to the commencement of any on-water activity (download at: <a href="https://media.fisheries.noaa.gov/dam-migration/sea_turtle_handling_and_resuscitation_measures.pdf">https://media.fisheries.noaa.gov/dam-migration/sea_turtle_handling_and_resuscitation_measures.pdf</a>). These handling and resuscitation procedures would be carried out any time a sea turtle is incidentally captured and brought onboard the vessel during the Proposed Actions.</li> <li>g. If any sea turtles that appear injured, sick, or distressed, are caught and retrieved in fisheries survey gear, survey staff would immediately contact the Greater Atlantic Region Marine Animal Hotline at 866-755-6622 for further instructions and guidance on handling the animal, and potential coordination of transfer to a rehabilitation facility. If unable to contact the hotline (e.g., due to distance from shore or lack of ability to communicate via phone), the USCG should be contacted via VHF marine radio on Channel 16. If required, hard-shelled sea turtles (i.e., non-leatherbacks) may be held on board for up to 24 hours following handling instructions provided by the Hotline, prior to transfer to a rehabilitation facility.</li> <li>h. Attempts would be made to resuscitate any ESA-fish that are unresponsive or comatose by providing a running source of water over the gills as described in the Sturgeon Resuscitation Guidelines (download at: <a href="https://media.fisheries.noaa.gov/dam-migration/sturgeon_resuscitation_card_06122020_508.pdf">https://media.fisheries.noaa.gov/dam-migration/sturgeon_resuscitation_card_06122020_508.pdf</a>).</li> <li>i. Provided that appropriate cold storage facilities are available on the survey vessel, following the report of a dead sea turtle or sturgeon to NMFS, and if NMFS requests, any dead sea turtle or ESA-fish would be retained on board the survey vessel for transfer to an appropriately permitted partner or facility on shore as safe to do so.</li> <li>j. Any live sea turtles or ESA-fish caught and retrieved in gear used in any fisheries survey would ultimately be released according to established protocols and whenever at-sea conditions are safe for those releasing the animal(s) to do so.</li> </ul>	All fisheries surveys	Ensure the safe handling and resuscitation of sea turtles and Atlantic sturgeon following established protocols

No.	Activity	Measure	Description	Project Phase	Expected Effects
26	Fisheries sampling	Take notification	<p>GARFO PRD would be notified as soon as possible of all observed takes of sea turtles and ESA-fish occurring as a result of any fisheries survey. Specifically:</p> <ul style="list-style-type: none"> <li>k. GARFO PRD would be notified within 24 hours of any interaction with a sea turtle or ESA-fish (<a href="mailto:nmfs.gar.incidental-take@noaa.gov">nmfs.gar.incidental-take@noaa.gov</a>). The report would include at a minimum: (1) survey name and applicable information (e.g., vessel name, station number); (2) GPS coordinates describing the location of the interaction (in decimal degrees); (3) gear type involved (e.g., bottom trawl, gillnet, longline); (4) soak time, gear configuration and any other pertinent gear information; (5) time and date of the interaction; and (6) identification of the animal to the species level. Additionally, the email would transmit a copy of the NMFS Take Report Form (download at: <a href="https://media.fisheries.noaa.gov/2021-07/Take%20Report%20Form%2007162021.pdf?null">https://media.fisheries.noaa.gov/2021-07/Take%20Report%20Form%2007162021.pdf?null</a>) and a link to or acknowledgement that a clear photograph or video of the animal was taken (multiple photographs are suggested, including at least one photograph of the head scutes). If reporting within 24 hours is not possible due to distance from shore or lack of ability to communicate via phone, fax, or email, reports would be submitted as soon as possible; late reports would be submitted with an explanation for the delay.</li> <li>l. At the end of each survey season, a report would be sent to NMFS that compiles all information on any observations and interactions with ESA-listed species. This report would also contain information on all survey activities that took place during the season including location of gear set, duration of soak/trawl, and total effort. The report on survey activities would be comprehensive of all activities, regardless of whether ESA-listed species were observed.</li> </ul>	All fishery surveys	Establish procedures for immediate reporting of sea turtle/Atlantic sturgeon take
27	Reporting	Monthly / annual reporting	<p>Applicant proposed measures plus:</p> <p>BOEM would ensure that Dominion Energy implements the following reporting requirements necessary to document the amount or extent of take that occurs during all phases of the Proposed Action:</p> <ul style="list-style-type: none"> <li>m. All reports would be sent to: <a href="mailto:nmfs.gar.incidental-take@noaa.gov">nmfs.gar.incidental-take@noaa.gov</a>.</li> <li>n. During the construction phase and for the first year of operations, Dominion Energy would compile and submit monthly reports that include a summary of all project activities carried out in the previous month, including vessel transits (number, type of vessel, and route), and piles installed, and all observations of ESA-listed species. Monthly reports are due on the 15<sup>th</sup> of the month for the previous month.</li> <li>o. Beginning in year two of operations, Dominion Energy would compile and submit annual reports that include a summary of all project activities carried out in the previous year, including vessel transits (number, type of vessel, and route), repair and maintenance activities, survey activities, and all observations of ESA-listed species. These reports are due by April 1 of each year (i.e., the 2026 report is due by April 1, 2027). Upon mutual agreement of NMFS and BOEM, the frequency of reports can be changed.</li> </ul>	Construction and operations	Establish reporting requirements and timing to document take and operator activities

No.	Activity	Measure	Description	Project Phase	Expected Effects
28	Special Conditions	Special Conditions	Dominion Energy will comply with any special conditions and required mitigation associated with work authorized or permitted through Section 10 of the Rivers and Harbors Act of 1899, Section 404 of the Clean Water Act, and ESA terms and conditions landward of the Submerged Lands Act boundary.	All Phases	Establish requirement for avoidance, minimization, mitigation of impacts pursuant to Section 10, Section 404 and Submerge Lands Act

## 16 APPENDIX B: MITIGATION, MONITORING, AND REPORTING MEASURES IN THE PROPOSED MMPA AUTHORIZATION.

### Proposed Mitigation

In order to promulgate a rulemaking under section 101(a)(5)(A) of the MMPA, NMFS must set forth the permissible methods of taking pursuant to the activity, and other means of effecting the least practicable impact on the species or stock and its habitat, paying particular attention to rookeries, mating grounds, and areas of similar significance, and on the availability of the species or stock for taking for certain subsistence uses (latter not applicable for this action). NMFS' regulations require applicants for incidental take authorizations to include information about the availability and feasibility (economic and technological) of equipment, methods, and manner of conducting the activity or other means of effecting the least practicable adverse impact upon the affected species or stocks and their habitat (50 CFR 216.104(a)(11)).

In evaluating how mitigation may or may not be appropriate to ensure the least practicable adverse impact on species or stocks and their habitat, as well as subsistence uses where applicable, we carefully consider two primary factors:

(1) The manner in which, and the degree to which, the successful implementation of the measure(s) is expected to reduce impacts to marine mammals, marine mammal species or stocks, and their habitat. This considers the nature of the potential adverse impact being mitigated (likelihood, scope, range). It further considers the likelihood that the measure will be effective if implemented (probability of accomplishing the mitigating result if implemented as planned), the likelihood of effective implementation (probability implemented as planned), and;

(2) The practicability of the measures for applicant implementation, which may consider such things as cost, impact on operations, and, in the case of a military readiness activity, personnel safety, practicality of implementation, and impact on the effectiveness of the military readiness activity.

The mitigation strategies described below are consistent with those required and successfully implemented under previous incidental take authorizations issued in association with in-water construction activities (*e.g.*, soft-start, establishing shutdown zones). Additional measures have also been incorporated to account for the fact that the proposed construction activities would occur offshore. Modeling was performed to estimate harassment zones, which were used to inform mitigation measures for pile driving activities to minimize Level A harassment and Level B harassment to the extent practicable while providing estimates of the areas within which Level B harassment might occur.

Generally speaking, the measures considered and proposed here fall into three categories: temporal (seasonal and daily) work restrictions, real-time measures (shutdown, clearance zones, and vessel strike avoidance), and noise reduction measures. Seasonal work restrictions are designed to avoid or minimize operations when marine mammals are concentrated or engaged in behaviors that make them more susceptible or make impacts more likely. Temporal restrictions are also designed to reduce both the number and severity of potential takes, and are effective in reducing both chronic (longer-term) and acute effects. Real-time measures, such as clearance and shutdown requirements and vessel strike avoidance measures, are intended to reduce the probability or scope of near-term acute impacts by taking steps in real time once a higher-risk scenario is identified (*i.e.*, once animals are detected within an impact zone). Noise reduction measures, such as the use of noise abatement devices like bubble curtains, are intended to reduce the noise at the source, which reduces both acute impacts as well as the contribution to aggregate and cumulative noise that results in longer term chronic impacts.

Below, we describe measures that apply to all activity types, and then in the following subsections, we describe the measures that apply specifically to WTG and OSS foundation installation, cable landfall construction pile driving, HRG surveys, and fishery monitoring surveys.

Although the language contained in this proposed rule directly refers to the applicant, Dominion Energy, all proposed measures discussed herein would also apply to any persons Dominion Energy authorizes or funds to conduct activities on its behalf specific to the CVOW-C project.

### **Training and Coordination**

All relevant personnel and the marine mammal monitoring team(s) would be required to participate in joint, onboard briefings that would be led by CVOW-C project personnel and the Lead PSO prior to the beginning of project activities. This would serve to ensure that all relevant responsibilities, communication procedures, marine mammal monitoring and mitigation protocols, reporting protocols, safety, operational procedures, and ITA requirements are clearly understood by all involved parties. The briefing would be repeated whenever new relevant personnel (*e.g.*, new PSOs, acoustic source operators, relevant crew) join the operation before work commences. During this training, Dominion Energy would be required to instruct all project personnel regarding the authority of the marine mammal monitoring team(s). For example, the HRG acoustic equipment operator, pile driving personnel, *etc.*, would be required to immediately comply with any call for a delay or shutdown by the Lead PSO. Any disagreement between the Lead PSO and the project personnel would only be discussed after delay or shutdown has occurred. More information on vessel crew training requirements can be found in the *Vessel Strike Avoidance Measures* sections below.

### **Protected Species Observers and PAM Operator Training**

Dominion Energy would employ NMFS-approved PSOs and PAM operators. The PSO field team and PAM team would have a lead member (designated as the “Lead PSO” or “PAM Lead”) who would have prior experience observing mysticetes, odontocetes, and pinnipeds in the northwestern Atlantic Ocean on other offshore projects requiring PSOs. Any remaining PSOs and PAM operators must have previous experience observing marine mammals during projects and must have the ability to work with all required and relevant software and equipment. New and/or inexperienced PSOs would be paired with an experienced PSO to ensure that the quality of marine mammal observations and data recording is kept consistent. Additional information on the roles and requirements of the PAM operators (section 4.1.1.2) and PSOs (section 4.1.1.3) can be found in Dominion Energy’s supplemental Protected Species Mitigation and Monitoring Plan (PSMMP) on NMFS’ website (<https://www.fisheries.noaa.gov/action/incidental-take-authorization-dominion-energy-virginia-construction-coastal-virginia>).

Prior to the start of activities, a briefing would be conducted between the supervisors, the crew, the PSO/PAM team, the environmental compliance monitors, and Dominion Energy personnel. This briefing would be to establish the responsibilities of each participating party, to define the chains of command, to discuss communication procedures, to provide an overview of the monitoring purposes, and to review the operational procedures. The designated PSO (*i.e.*, Lead PSO) would oversee the training, the environmental compliance monitors, the PSOs, and other tasks specifically related to monitoring. More information on the specific roles and requirements of the Lead PSO can be found in section 4.1.1.1 of Dominion Energy’s PSMMP.

### **North Atlantic Right Whale Awareness Monitoring**

Dominion Energy must use available sources of information on North Atlantic right whale presence, including daily monitoring of the Right Whale Sightings Advisory System, monitoring of Coast Guard VHF Channel 16 throughout each day to receive notifications of any sightings, and information associated with any regulatory management actions (*e.g.*, establishment of a zone identifying the need to reduce vessel speeds). Maintaining daily awareness and coordination affords increased protection of North Atlantic right whales by understanding North Atlantic right whale presence in the area through ongoing visual and passive acoustic monitoring efforts and opportunities (outside of Dominion Energy’s efforts) and allows for planning of construction activities, when practicable, to minimize potential impacts on North Atlantic right whales.

Given the CVOW-C project is occurring within the general vicinity of the North Atlantic right whale SMA located outside of the mouth of the Chesapeake Bay, all vessels would be required to comply with the Mid-

Atlantic Seasonal Management Area (SMA) mandatory speed restriction period (November 1<sup>st</sup> through April 30<sup>th</sup>) for all activities. Dominion Energy would also be required to monitor the NOAA Fisheries North Atlantic Right Whale reporting system for the establishment of a Dynamic Management Area (DMA).

### **Vessel Strike Avoidance Measures**

This proposed rule contains numerous vessel strike avoidance measures. Dominion Energy will be required to comply with these measures except under circumstances when doing so would create an imminent and serious threat to a person or vessel or to the extent that a vessel is unable to maneuver and because of the inability to maneuver, the vessel cannot comply (*e.g.*, due to towing, *etc.*). Vessel operators and crews will receive protected species identification training prior to the start of in-water construction activities. This training will cover information about marine mammals and other protected species known to occur or which have the potential to occur in the project area. It will include training on making observations in both good weather conditions (*i.e.*, clear visibility, low wind, and low sea state) and bad weather conditions (*i.e.*, fog, high winds and high sea states, in glare). Training will not only include identification skills but will also include information and resources available regarding applicable Federal laws and regulations for protected species. In addition, all vessels must be equipped with an Automatic Identification System (AIS) and Dominion Energy must report all Maritime Mobile Service Identify (MMSI) numbers to NMFS Office of Protected Resources prior to initiating in-water activities

Dominion Energy will abide by the following vessel strike avoidance measures:

- All vessel operators and crews must maintain a vigilant watch for all marine mammals and slow down, stop their vessel, or alter course (as appropriate) to avoid striking any marine mammal.
- During any vessel transits within or to/from the CVOW-C project area, such as for crew transfers, an observer would be stationed at the best vantage point of the vessel(s) to ensure that the vessel(s) are maintaining the appropriate separation distance from marine mammals.
- Year-round and when a vessel is in transit, all vessel operators will continuously monitor U.S. Coast Guard VHF Channel 16 over which North Atlantic right whale sightings are broadcasted.
- At the onset of transiting and at least once every four hours, vessel operators and/or trained crew members will monitor the project's Situational Awareness System, WhaleAlert, and the Right Whale Sighting Advisory System (RWSAS) for the presence of North Atlantic right whales.
- Any observations of any large whale by any Dominion Energy staff or contractors, including vessel crew, must be communicated immediately to PSOs, PAM operator, and all vessel captains to increase situational awareness. Conversely, any large whale observation or detection via a sighting network (*e.g.*, Mysticetus) by PSOs or PAM operators will be conveyed to vessel operators and crew.
- All vessels would comply with existing NMFS regulations and speed restrictions and state regulations, as applicable, for North Atlantic right whales.
- In the event that any Slow Zone (DMA or acoustically triggered slow zone) is established that overlaps with an area where a project-associated vessel would operate, that vessel, regardless of size, will transit that area at 10 kts or less.
- Between November 1<sup>st</sup> and April 30<sup>th</sup>, all vessels, regardless of size, would operate at 10 kts or less.
- All vessels, regardless of size, would immediately reduce speed to 10 kts or less when any large whale, whale mother/calf pairs, or large assemblages of non-delphinid cetaceans are observed near (within 100 m) an underway vessel.
- All vessels, regardless of size, would immediately reduce speed to 10 kts or less when a North Atlantic right whale is sighted, at any distance, by an observer or anyone else on the vessel.

- All transiting vessels (*e.g.*, transiting, surveying) must have a dedicated visual observer on duty at all times to monitor for marine mammals within a 180° direction of the forward path of the vessel (90° port to 90° starboard). Visual observers must be equipped with alternative monitoring technology for periods of low visibility (*e.g.*, darkness, rain, fog, *etc.*). The dedicated visual observer must receive prior training on protected species detection and identification, vessel strike minimization procedures, how and when to communicate with the vessel captain, and reporting requirements in this proposed action. Visual observers may be third-party observers (*i.e.*, NMFS-approved PSOs) or crew members and must not have any other duties other than observing for marine mammals. Observer training related to these vessel strike avoidance measures must be conducted for all vessel operators and crew prior to the start of in-water construction activities to distinguish marine mammals from other phenomena and broadly to identify a marine mammal as a North Atlantic right whale, other whale (defined in this context as sperm whales or baleen whales other than North Atlantic right whales), or other marine mammal. Confirmation of the observers' training and understanding of the ITA requirements must be documented on a training course log sheet and reported to NMFS.
- All vessels must maintain a minimum separation distance of 500 m from North Atlantic right whales. If a whale is observed but cannot be confirmed as a species other than a North Atlantic right whale, the vessel operator must assume that it is a North Atlantic right whale and take appropriate action.
- All transiting vessels must steer a course away from any sighted North Atlantic right whale at 10 kts or less such that the 500-m minimum separation distance requirement is not violated. If a North Atlantic right whale or a large whale that cannot be confirmed as a species other than a North Atlantic right whale is sighted within 500 m of an underway vessel, that vessel must shift the engine to neutral. Engines will not be engaged until the whale has moved outside of the vessel's path and beyond 500 m. If a whale is observed but cannot be confirmed as a species other than a North Atlantic right whale, the vessel operator must assume that it is a North Atlantic right whale and take appropriate action.
- All vessels must maintain a minimum separation distance of 100 m from sperm whales and non-North Atlantic right whale baleen whales. If one of these species is sighted within 100 m of a transiting vessel, that vessel must shift the engine to neutral. Engines will not be engaged until the whale has moved outside of the vessel's path and beyond 100 m.
- All vessels must, to the maximum extent practicable, attempt to maintain a minimum separation distance of 50 m from all delphinid cetaceans and pinnipeds with an exception made for those that approach the vessel (*e.g.*, bow-riding dolphins). If a delphinid cetacean or pinniped is sighted within 50 m of an underway vessel, that vessel must shift the engine to neutral (again, with an exception made for those that approach the vessel). Engines will not be engaged until the animal(s) has moved outside of the vessel's path and beyond 50 m.
- When a marine mammal(s) is sighted while a vessel is transiting, the vessel must take action as necessary to maintain the relevant separation distances (*e.g.*, attempt to remain parallel to the animal's course, avoid excessive speed or abrupt changes in direction until the animal has left the area). If a marine mammal(s) is sighted within the relevant separation distance, the vessel must reduce speed and shift the engine to neutral, not engaging the engine(s) until the animal(s) is clear of the area. This does not apply to any vessel towing gear or any situation where respecting the relevant separation distance would be unsafe (*i.e.*, any situation where the vessel is navigationally constrained).
- All transiting vessels must not divert or alter course in order to approach any marine mammal.



- For in-water construction heavy machinery activities, other than impact or vibratory pile driving, if a marine mammal is on a path towards or comes within 10 m of equipment, Dominion Energy must cease operations until the marine mammal has moved more than 10 m on a path away from the activity to avoid direct interaction with equipment.
- Dominion Energy must submit a North Atlantic right whale vessel strike avoidance plan 180 days prior to commencement of vessel use. The plan would, at minimum, describe how PAM, in combination with visual observations, would be conducted to ensure the transit corridor is clear of right whales. The plan would also provide details on the vessel-based observer protocols on transiting vessels.

### **WTG and OSS Foundation Installation**

For WTG and OSS foundation installation, NMFS is proposing to include the following mitigation requirements, which are described in detail below: seasonal and daily restrictions; the use of noise abatement systems; the use of PSOs and PAM operators; the implementation of clearance and shutdown zones, and the use of soft-start.

#### **Seasonal and Daily Restrictions**

No foundation pile driving activities (inclusive of both vibratory and impact pile driving) would occur from November 1<sup>st</sup> through April 30<sup>th</sup> of any year. Based on the best scientific information available (*i.e.*, Roberts and Halpin, 2022), the highest densities of North Atlantic right whales in the project area are expected during the months of November through April. NMFS is proposing to require this seasonal work restriction to minimize the exposure of North Atlantic right whales to noise incidental to both vibratory and impact pile driving of monopiles (for the WTGs) and jacket pin piles (for the OSSs), which is expected to greatly reduce the number of takes of North Atlantic right whales.

No more than two foundation monopiles would be installed per day. Monopiles would be no larger than 9.5-m in diameter, representing the larger end of the tapered 9.5/7.5-m monopile design. For all monopiles, the minimum amount of hammer energy necessary to effectively and safely install and maintain the integrity of the piles must be used. These hammer energies must not exceed 4,000 kJ. Similarly, no more than two foundation pin piles would be installed per day. Pin piles for jacket foundations would be no larger than 2.8-m in diameter. A jacket foundation design no larger than a four-legged design must be used (four pin piles per jacket foundation). For all pin piles, the minimum amount of hammer energy necessary to effectively and safely install and maintain the integrity of the piles must be used. These hammer energies must not exceed 3,000 kJ. Dominion Energy would initiate pile driving (inclusive of both vibratory and impact) no earlier than one hour after civil sunrise or no later than 1.5 hours before civil sunset. Dominion Energy has not proposed nighttime pile driving other than if pile driving continues after dark. This would only occur when installation of the same pile begins during daylight (*i.e.*, 1.5 hours before civil sunset). Dominion Energy would need to adequately monitor all relevant zones to ensure the most effective mitigative actions are being undertaken. Additional restrictions are discussed in the following Clearance and Shutdown Zones section.

#### **Noise Abatement Systems**

Dominion Energy would employ noise abatement systems (NAS), also known as noise attenuation systems, during all vibratory and impact pile driving of monopiles and pin piles to reduce the sound pressure levels that are transmitted through the water in an effort to reduce ranges to acoustic thresholds and minimize any acoustic impacts resulting from pile driving. Dominion Energy would be required to employ a big double bubble curtain (as was used during the CVOW Pilot Project), other technology capable of achieving a 10-dB sound level reduction, or a combination of two or more NAS capable of achieving a 10-dB sound level reduction during these activities as well as the adjustment of operational protocols to minimize noise levels.

Two categories of NAS exist: primary and secondary. A primary NAS would be used to reduce the level of noise produced by the pile driving activities at the source, typically through adjustments on to the equipment

(e.g., hammer strike parameters). Primary NAS are still evolving and will be considered for use during mitigation efforts when the NAS has been demonstrated as effective in commercial projects. However, as primary NAS are not fully effective at eliminating noise, a secondary NAS would be employed. The secondary NAS is a device or group of devices that would reduce noise as it was transmitted through the water away from the pile, typically through a physical barrier that would reflect or absorb sound waves and therefore, reduce the distance the higher energy sound propagates through the water column. Together, these systems must reduce noise levels to the lowest level practicable with the goal of not exceeding measured ranges to Level A harassment and Level B harassment isopleths corresponding to those modeled assuming 10-dB sound attenuation, pending results of Sound Field Verification (SFV; see the *Acoustic Monitoring for Sound Field and Harassment Isopleth Verification* section).

Noise abatement systems, such as bubble curtains, are used to decrease the sound levels radiated from a source. Bubbles create a local impedance change that acts as a barrier to sound transmission. The size of the bubbles determines their effective frequency band, with larger bubbles needed for lower frequencies. There are a variety of bubble curtain systems, confined or unconfined bubbles, and some with encapsulated bubbles or panels. Attenuation levels also vary by type of system, frequency band, and location. Small bubble curtains have been measured to reduce sound levels but effective attenuation is highly dependent on depth of water, current, and configuration and operation of the curtain (Austin *et al.*, 2016; Koschinski and Lüdemann, 2013). Bubble curtains vary in terms of the sizes of the bubbles and those with larger bubbles tend to perform a bit better and more reliably, particularly when deployed with two separate rings (Bellmann, 2014; Koschinski and Lüdemann, 2013; Nehls *et al.*, 2016). Encapsulated bubble systems (e.g., Hydro Sound Dampers (HSDs)), can be effective within their targeted frequency ranges (e.g., 100-800 Hz), and when used in conjunction with a bubble curtain appear to create the greatest attenuation. The literature presents a wide array of observed attenuation results for bubble curtains. The variability in attenuation levels is the result of variation in design as well as differences in site conditions and difficulty in properly installing and operating in-water attenuation devices. Secondary NAS that may be used by Dominion Energy include a big bubble curtain (BBC), a hydro-sound damper, or an AdBm Helmholtz resonator (Elzinga *et al.*, 2019). If a single system is used, it must be a double big bubble curtain (dBBC). Other dual systems (e.g., noise mitigation screens, hydro-sound damper, AdBm Helmholtz resonator) are being considered for the CVOW-C project, although many of these are in their early stages of development and field tests to evaluate performance and effectiveness have not been completed. Should the research and development phase of these newer systems demonstrate effectiveness, as part of adaptive management, Dominion Energy may submit data on the effectiveness of these systems and request approval from NMFS to use them during vibratory and impact pile driving.

The literature presents a wide array of observed attenuation results for bubble curtains. The variability in attenuation levels is the result of variation in design as well as differences in site conditions and difficulty in properly installing and operating in-water attenuation devices. Dähne *et al.* (2017) found that single bubble curtains that reduce sound levels by 7 to 10 dB reduced the overall sound level by approximately 12 dB when combined as a double bubble curtain for 6-m steel monopiles in the North Sea. During installation of monopiles (consisting of approximately 8-m in diameter) for more than 150 WTGs in comparable water depths (> 25 m) and conditions in Europe indicate that attenuation of 10 dB is readily achieved (Bellmann, 2019; Bellmann *et al.*, 2020) using single BBCs for noise attenuation. Designed to gather additional data regarding the efficacy of BBCs, the CVOW Pilot Project systematically measured noise resulting from the impact driven installation of two 7.8-m diameter monopiles, one installation using a dBBC and the other installation using no noise abatement system (CVOW, unpublished data). Although many factors contributed to variability in received levels throughout the installation of the piles (e.g., hammer energy, technical challenges during operation of the dBBC), reduction in broadband SEL using the dBBC (comparing measurements derived from the mitigated and the unmitigated monopiles) ranged from approximately 9-15 dB.

If a bubble curtain is used (single or double), Dominion Energy would be required to maintain the following operational parameters: the bubble curtain(s) must distribute air bubbles using a target air flow rate of at least  $0.5 \text{ m}^3/(\text{min} \cdot \text{m})$  and must distribute bubbles around 100% of the piling perimeter for the full depth of the water column. The lowest bubble ring must be in contact with the seafloor for the full circumference of the ring, and the weights attached to the bottom ring must ensure 100-percent seafloor contact; no parts of the ring or other objects should prevent full seafloor contact. Dominion Energy must require that construction contractors train personnel in the proper balancing of airflow to the bubble ring and must require that construction contractors submit an inspection/performance report for approval by Dominion Energy within 72 hours following the performance test. Corrections to the attenuation device to meet the performance standards must occur prior to impact driving of monopiles. If Dominion Energy uses a noise mitigation device in addition to a BBC, similar quality control measures would be required.

Again, NMFS would require Dominion Energy to apply a dBBC or a single BBC coupled with an additional noise mitigation device to ensure sound generated from the project does not exceed that modeled (assuming 10-dB reduction) at given ranges to harassment isopleths and to minimize noise levels to the lowest level practicable. Double BBCs are successfully and widely applied across European wind development efforts and are known to reduce noise levels more than single BBC alone (*e.g.*, Bellman *et al.*, 2020). Dominion Energy anticipates and NMFS agrees that the use of a noise abatement system would likely produce field measurements of the isopleth distances to the Level A harassment and Level B harassment thresholds that accord with those modeled assuming 10-dB of attenuation for vibratory and impact pile driving of monopiles and pin piles (refer back to the **Estimated Take, Proposed Mitigation, and Proposed Monitoring and Reporting** sections).

#### **Use of PSOs and PAM Operators**

As described above, Dominion Energy would be required to use PSOs and acoustic PSOs (*i.e.*, PAM operators) during all WTG and OSS foundation installation activities. Dominion Energy would be required to utilize a team of sufficient size to allow for appropriate implementation of mitigation measures and monitoring. At a minimum, four PSOs would be actively observing marine mammals before, during, and after pile driving. At least two PSOs would be stationed on the primary pile driving installation vessel and at least two PSOs would be stationed on a secondary, dedicated PSO vessel. The dedicated PSO vessel would be positioned approximately 3 km from the pile being driven and circle the pile at a speed of less than 10 kts. Concurrently, at least one PAM operator would be actively monitoring for marine mammals before, during, and after pile driving. PSOs fulfilling the role of both the PAM operator and PSO may be utilized interchangeably, if all relevant experience and educational requirements are met; however, PAM operators/PSOs must only serve in one capacity per watch period. During all monopile installation and in the two days prior to and daily throughout the construction, the Lead PSO would continue to consult the NOAA Fisheries North Atlantic right whale reporting systems for the presence of North Atlantic right whales. More details on PSO and PAM operator requirements can be found in the **Proposed Monitoring and Reporting** section.

As a requirement that is not only exclusive to PAM operators and PSOs, all crew and personnel working on the CVOW-C project would be required to maintain situational awareness of marine mammal presence (discussed further above) and would be required to report any sightings to the PSOs for implementation of mitigation measures, if necessary.

#### **Clearance and Shutdown Zones**

NMFS is proposing to require the establishment of both clearance and shutdown zones during all impact and vibratory pile driving of monopiles and pin piles, which would be monitored by visual PSOs and PAM operators before, during and after pile driving. PSOs must visually monitor clearance zones for marine mammals for a minimum of 60 minutes immediately prior to commencing pile driving. At least one PAM operator must review data from at least 24 hours prior to pile driving and actively monitor hydrophones for 60 minutes immediately prior to pile driving. Prior to initiating soft-start procedures, all clearance zones must be

visually confirmed to be free of marine mammals for 30 minutes immediately prior to starting a soft-start of pile driving. If a marine mammal is observed entering or within the relevant clearance zone prior to the initiation of impact pile driving activities, pile driving must be delayed and will not begin until either the marine mammal(s) has voluntarily left the specific clearance zones and have been visually or acoustically confirmed beyond that clearance zone or when specific time periods have elapsed with no further sightings or acoustic detections have occurred (*i.e.*, 15 minutes for small odontocetes and 30 minutes for all other marine mammal species).

The purpose of “clearance” of a particular zone is to prevent or minimize potential instances of auditory injury and more severe behavioral disturbances by delaying the commencement of impact pile driving if marine mammals are near the activity. Prior to the start of impact pile driving activities, Dominion Energy would ensure the area is clear of marine mammals, per the clearance zones presented in Tables 30 and 31, to minimize the potential for and degree of harassment. Once pile driving activity begins, any marine mammal entering the shutdown zone would trigger pile driving to cease (unless shutdown is not practicable due to imminent risk of injury or loss of life to an individual or risk of damage to a vessel that creates risk of injury or loss of life for individuals). The purpose of a shutdown is to prevent a specific acute impact, such as auditory injury or severe behavioral disturbance of sensitive species, by halting the activity.

In addition to the clearance and shutdown zones that would be monitored both visually and acoustically, NMFS is proposing to establish a minimum visibility zone to ensure both visual and acoustic methods are used in tandem to detect marine mammals resulting in maximum detection capability. The minimum visibility zone that has been proposed by Dominion Energy would extend 1,750 m from the pile being driven during all months in which foundation installation is planned to occur. This value was proposed by Dominion Energy as it corresponds to the Exclusion Zone implemented during the CVOW Pilot Project (see 85 FR 30930, May 21, 2020). While NMFS acknowledges that this distance was adequate and appropriate for the CVOW Pilot Project, the turbine models for the proposed CVOW-C project are much larger (7.8-m versus 9.5-m, respectively) and would require a much larger maximum hammer energy (1,000 kJ maximum versus 4,000 kJ maximum). These factors create a larger distance to the Level A harassment threshold than the CVOW Pilot Project. Because of these reasons, NMFS has instead proposed a minimum visibility distance for WTG monopile and OSS pin pile installation as 2,000 m.

During all foundation installation, Dominion Energy must ensure that the entire minimum visibility zone (as based on the installation activity occurring) is visible (*i.e.*, not obscured by dark, rain, fog, *etc.*) for a full 30 minutes immediately prior to commencing vibratory or impact pile driving. In addition, the entire clearance zone must be visually clear of marine mammals prior to commencing vibratory or impact pile driving. For North Atlantic right whales, there is an additional requirement that the clearance zone may only be declared clear if no confirmed North Atlantic right whale acoustic detections (in addition to visual) have occurred during the 60-minute monitoring period. Any large whale sighted by a PSO or acoustically detected by a PAM operator that cannot be identified as a non-North Atlantic right whale must be treated as if it were a North Atlantic right whale.

Proposed clearance and shutdown zones have been developed in consideration of modeled distances to relevant PTS thresholds with respect to minimizing the potential for take by Level A harassment. All proposed clearance and shutdown zones for large whales are larger than the largest modeled acoustic range ( $R_{95\%}$ ) distances to thresholds corresponding to Level A harassment (SEL and peak).

If a marine mammal is observed entering or within the respective shutdown zone (Tables 30 and 31) after pile driving has begun, the PSO will request a temporary cessation of pile driving. Dominion Energy will stop pile driving immediately unless Dominion Energy determines shutdown is not practicable due to imminent risk of injury or loss of life to an individual or risk of damage to a vessel that creates risk of injury or loss of life for individuals or the lead engineer determines there is pile refusal or pile instability. Pile refusal occurs when the pile driving sensors indicate the pile is approaching refusal, and a shut-down would lead to a stuck pile which

then poses an imminent risk of injury or loss of life. Pile instability occurs when the pile is unstable and unable to stay standing if the piling vessel were to “let go.” During these periods of instability, the lead engineer may determine a shutdown is not feasible because the shutdown combined with impending weather conditions may require the piling vessel to “let go”, which then poses an imminent risk of injury or loss of life, pile refusal, or pile instability. In any of these situations, Dominion Energy must reduce hammer energy to the lowest level practicable and the reason(s) for not shutting down must be documented and reported to NMFS.

The lead engineer must evaluate the following to determine if a shutdown is safe and practicable:

- a. Use of site-specific soil data and real-time hammer log information to judge whether a stoppage would risk causing piling refusal at re-start of piling;
- b. Confirmation that pile penetration is deep enough to secure pile stability in the interim situation, taking into account weather statistics for the relevant season and the current weather forecast; and
- c. Determination by the lead engineer on duty will be made for each pile as the installation progresses and not for the site as a whole.

If it is determined that shutdown is not feasible, the reason must be documented and reported (see **Proposed Monitoring and Reporting** section).

Subsequent restart of the equipment can be initiated if the animal has been observed exiting its respective shutdown zone within 30 minutes of the shutdown, or, after an additional time period has elapsed with no further sighting (*i.e.*, 15 minutes for small odontocetes and pinnipeds and 30 minutes for all other species). The clearance and shutdown zone sizes vary by species and are shown in Tables 30 and 31. All distances to the perimeter of these mitigation zones are the radii from the center of the pile. Pursuant to the proposed adaptive management provisions, Dominion Energy may request modification to these zone sizes pending results of sound field verification (see **Proposed Monitoring and Reporting** section). Any changes to zone size would require NMFS’ prior approval.

**Table 30 – Mitigation Zone Distances To The Level A Harassment And Level B Harassment Thresholds During Vibratory And Impact Pile Driving Of WTG Monopile Foundations, Assuming The Maximum Daily Build-Out (Two Piles Installed Per Day) And Deep Water Conditions (Inclusive Of 10 dB Of Sound Attenuation)**

Marine Mammals	WTG Monopile Foundations <sup>a, b</sup>							
	Impact Pile Driving Installation				Vibratory Pile Driving Installation			
	Clearance Zone (m)		Shutdown Zone (m)		Clearance Zone (m)		Shutdown Zone (m)	
	One Pile Per Day	Two Piles Per Day	One Pile Per Day	Two Piles Per Day	One Pile Per Day	Two Piles Per Day	One Pile Per Day	Two Piles Per Day
North Atlantic right whale - PAM detection	Any distance				Any distance			
North Atlantic right whale - visual detection	Any distance				Any distance			
All other Mysticetes and sperm whales	5,100	6,500	1,750	1,750	1,000	1,000	1,000	1,000
Dolphins and Pilot whales	500	500	500	500	250	250	250	250
Harbor porpoises	750	750	750	750	500	500	500	500
Seals	500	500	500	500	250	250	250	250

*a - The minimum visibility zone, an area in which marine mammals must be able to be visually detected, extends 2.0 km.*

*b - Dominion Energy may request modification of these zones based on the results of sound field verification.*

**Table 31 – Mitigation Zone Distances To The Level A Harassment And Level B Harassment Thresholds During Vibratory And Impact Pile Driving Of OSS Jacket Foundations, Assuming The Maximum Daily Build-Out (Two Pin Piles Installed Per Day; Inclusive Of 10 dB Of Sound Attenuation)**

Marine Mammals	OSS Jacket Foundations <sup>a, b</sup>							
	Impact Pile Driving Installation				Vibratory Pile Driving Installation			
	Clearance Zone (m)		Shutdown Zone (m)		Clearance Zone (m)		Shutdown Zone (m)	
	One Pile Per Day	Two Piles Per Day	One Pile Per Day	Two Piles Per Day	One Pile Per Day	Two Piles Per Day	One Pile Per Day	Two Piles Per Day
North Atlantic right whale - PAM detection	Any distance				Any distance			
North Atlantic right whale - visual detection	Any distance				Any distance			
All other Mysticetes and sperm whales	5,100	6,500	1,750	1,750	1,000	1,000	1,000	1,000
Dolphins and Pilot whales	500	500	500	500	250	250	250	250
Harbor porpoises	750	750	750	750	500	500	500	500
Seals	500	500	500	500	250	250	250	250

*a - The minimum visibility zone, an area in which marine mammals must be able to be visually detected, extends 2.0 km.*

*b - Dominion Energy may request modification of these zones based on the results of sound field verification.*

**Soft-Start**

The use of a soft-start procedure is believed to provide additional protection to marine mammals by warning them or providing them with a chance to leave the area prior to the hammer operating at full capacity. Soft-start typically involves initiating hammer operation at a reduced energy level (relative to full operating capacity) followed by a waiting period. Dominion Energy must utilize a soft-start protocol for impact pile driving of monopiles by performing 4-6 strikes per minute at 10 to 20% of the maximum hammer energy for a minimum of 30 minutes.

Soft-start will be required at the beginning of each day's monopile and pin pile installation and at any time following a cessation of vibratory or impact pile driving of 30 minutes or longer. If a marine mammal is detected within or about to enter the applicable clearance zones prior to the beginning of soft-start procedures, impact pile driving would be delayed until the animal has been visually observed exiting the clearance zone or until a specific time period has elapsed with no further sightings (*i.e.*, 15 minutes for small odontocetes and 30 minutes for all other species).

**Cable Landfall Activities - Temporary Cofferdams**

For the installation and removal of temporary cofferdams, NMFS is proposing to include the following mitigation requirements, which are described in detail below: daily restrictions; the use of PSOs; and the implementation of clearance and shutdown zones. Given the short duration of work and lower noise levels during vibratory driving, NMFS is not proposing to require PAM or noise abatement system use during these activities.

**Seasonal and Daily Restrictions**

Dominion Energy has proposed to install and remove all sheet piles associated with temporary cofferdams within the first year of the effective period of the regulations and LOA and has proposed to only perform these activities within the same seasonal work window as previously specified for foundation installation (*i.e.*, May 1<sup>st</sup> through October 31<sup>st</sup>). Dominion Energy also proposes to conduct pile driving associated with cable landfall construction during daylight hours. NMFS has carried forward these measures in this proposed rule.

**Use of PSOs**

Prior to the start of vibratory pile driving activities, at least two PSOs located at the best vantage points would monitor the clearance zone for 30 minutes, continue monitoring during vibratory pile driving, and for 30 minutes following cessation of the activity. The clearance zones must be fully visible for at least 30 minutes and all marine mammal(s) must be confirmed to be outside of the clearance zone for at least 30 minutes immediately prior to initiation of the activity.

**Clearance and Shutdown Zones**

Dominion Energy would establish clearance and shutdown zones for vibratory pile driving activities associated with sheet pile installation (Table 32). If a marine mammal is observed entering or is observed within the respective zones, activities will not commence until the animal has exited the zone or a specific amount of time has elapsed since the last sighting (*i.e.*, 30 minutes for large whales and 15 minutes for odontocetes and pinnipeds). If a marine mammal is observed entering or within the respective shutdown zone after vibratory pile driving has begun, the PSO will call for a temporary cessation of the activity. Pile driving must not be restarted until either the marine mammal(s) has voluntarily left the specific clearance zones and has been visually confirmed beyond that clearance zone or when specific time periods have elapsed with no further sightings or acoustic detections have occurred (*i.e.*, 15 minutes for small odontocetes and 30 minutes for all other marine mammal species). Because a vibratory hammer can grip a pile without operating, pile instability should not be a concern and no caveat for not ceasing pile driving due to pile instability would be allowed. However, the lead engineer may determine that pile driving cannot cease due to risk to human safety or equipment damage.



The clearance and shutdown zone sizes vary by species and are shown in Table 32. All distances to the perimeter of these mitigation zones are the radii from the center of the pile. Dominion Energy is not proposing, and NMFS is not requiring, sound field verification, hence these distances would not change.

**Table 32 – Distances To Mitigation Zones During Nearshore Cable Landfall Activities (Temporary Cofferdams)**

Marine Mammals	Installation and Removal of Temporary Cofferdams	
	Clearance Zone (m)	Shutdown Zone (m)
North Atlantic right whale - visual detection	Any distance	
All other Mysticetes and sperm whales	1,000	1,000
Delphinids	250	100
Pilot whales	1,000	1,000
Harbor porpoises	250	100
Seals	250	100

### Cable Landfall Activities - Temporary Goal Posts

For the installation of temporary goal posts, NMFS is proposing to include the following mitigation requirements, which are described in detail below: daily restrictions; the use of PSOs; the implementation of clearance and shutdown zones; and the use of soft-start. Given the short duration of work and relatively small harassment zones, NMFS is not proposing to require PAM or noise abatement system use during these activities.

### Seasonal and Daily Restrictions

Dominion Energy has proposed to install all pile pipes associated with temporary goal posts within the first year of the effective period of the regulations and LOA and has proposed to only perform these activities within the same seasonal work window as previously specified for foundation installation (*i.e.*, May 1<sup>st</sup> through October 31<sup>st</sup>). Similar to cofferdam work, Dominion Energy is not proposing to conduct goal post installation during daylight hours. Because removal of goal posts would be conducted via means that do not produce noise (see the **Description of the Specified Activities** section), removal could occur during darkness.

### Use of PSOs

Prior to the start of impact hammering activities, at least two PSOs located at the best vantage points would monitor the clearance zone for 30 minutes, continue monitoring during impact pile driving, and for 30 minutes following cessation of the activity. The clearance zones must be fully visible for at least 30 minutes and

all marine mammal(s) must be confirmed to be outside of the clearance zone for at least 30 minutes immediately prior to initiation of the activity.

**Clearance and Shutdown Zones**

Dominion Energy would establish clearance and shutdown zones for impact pile driving for casing pipe installation (Table 33). If a marine mammal is observed entering or is observed within the respective zones, activities will not commence until the animal has exited the zone or a specific amount of time has elapsed since the last sighting (*i.e.*, 30 minutes for large whales and 15 minutes for dolphins, porpoises, and pinnipeds). If a marine mammal is observed entering or within the respective shutdown zone after impact pile driving has begun, the PSO will call for a temporary cessation of the activity. Pile driving must not be restarted until either the marine mammal(s) has voluntarily left the specific clearance zones and has been visually confirmed beyond that clearance zone or when specific time periods have elapsed with no further sightings or acoustic detections have occurred (*i.e.*, 15 minutes for small odontocetes and 30 minutes for all other marine mammal species). The clearance and shutdown zone sizes vary by species and are shown in Table 33. All distances to the perimeter of these mitigation zones are the radii from the center of the pile. Dominion Energy is not proposing, and NMFS is not requiring, sound field verification, hence these distances would not change.

**Table 33 – Distances To Mitigation Zones During Nearshore Cable Landfall Activities (Temporary Goal Posts)**

Marine Mammals	Installation of Temporary Goal Posts	
	Clearance Zone (m)	Shutdown Zone (m)
North Atlantic right whale - visual detection	Any distance	
All other Mysticetes and sperm whales	1,000	1,000
Delphinids	250	100
Pilot whales	1,000	1,000
Harbor porpoises	750	100
Seals	500	100

**Soft-Start**

Dominion Energy did not provide specific details in either their ITA application or their PSMMP as to the soft-start plan that would be implemented for piles associated with temporary goal posts, however, NMFS proposes the following approach below, which is similar to the soft-start requirements proposed for WTG and OSS foundation installation via impact pile driving.

Dominion Energy must utilize a soft-start protocol for impact pile driving of goal post pipe piles. Soft-start requires contractors to provide an initial set of three strikes at reduced energy, followed by a 30-second waiting period, then two subsequent reduced-energy strike sets. Soft-start will be required at the beginning of the installation procedure for each goal post pipe pile and at any time following a cessation of impact pile driving of 30 minutes or longer. If a marine mammal is detected within or about to enter the applicable clearance zones prior to the beginning of soft-start procedures, impact pile driving would be delayed until the animal has been visually observed exiting the clearance zone or until a specific time period has elapsed with no further sightings (*i.e.*, 15 minutes for small odontocetes and 30 minutes for all other species).

### **HRG Surveys**

For HRG surveys, NMFS is proposing to include the following mitigation requirements, which are described in detail below, for all HRG survey activities using boomers, sparkers, and CHIRPs: the use of PSOs; the implementation of clearance, shutdown, and vessel separation zones; and ramp-up of survey equipment. There are no mitigation measures prescribed for sound sources operating at frequencies greater than 180 kHz as these would be expected to fall outside of marine mammal hearing ranges and not result in harassment; however, all HRG survey vessels would be subject to the aforementioned vessel strike avoidance measures described earlier in this section. Furthermore, due to the frequency range and characteristics of some of the sound sources, take is not anticipated for non-impulsive sources (*e.g.*, Ultra-Short BaseLine (USBL) and other parametric sub-bottom profilers) with exception to usage of CHIRPS and other non-parametric sub-bottom profilers. Hence, mitigation measures are only prescribed for CHIRPS, boomers and sparkers. PAM would not be required during HRG surveys. While NMFS agrees that PAM can be an important tool for augmenting detection capabilities in certain circumstances, its utility in further reducing impacts during HRG survey activities is limited. We have provided a thorough description of our reasoning for not requiring PAM during previous HRG surveys in several **Federal Register** notices (*e.g.*, 87 FR 40796, July 8, 2022; 87 FR 52913, August 3, 2022; 87 FR 51356, August 22, 2022).

### **Seasonal and Daily Restrictions**

Given the potential impacts to marine mammals from exposure to HRG survey noise sources are relatively minor (*e.g.*, limited to Level B harassment) and that the distances to the Level B harassment isopleth are very small (maximum distance is 100 m via the GeoMarine Dual 400 Sparker at 800 J), NMFS is not proposing to implement any seasonal or time-of-day restrictions for HRG surveys.

Although no temporal restrictions are proposed, NMFS would require Dominion Energy to deactivate acoustic sources during periods where no data is being collected except as determined necessary for testing. Any unnecessary use of the acoustic source would be avoided.

### **Use of PSOs**

During all HRG survey activities using boomers, sparkers, and CHIRPS, one PSO would be required to monitor during daylight hours and two would be required to monitor during nighttime hours per vessel. PSOs would begin visually monitoring 30 minutes prior to the initiation of the specified acoustic source (*i.e.*, ramp-up, if applicable) through 30 minutes after the use of the specified acoustic source has ceased. PSOs would be required to monitor the appropriate clearance and shutdown zones. These zones would be based around the radial distance from the acoustic source and not from the vessel.

### **Clearance, Shutdown, and Vessel Separation Zones**

Dominion Energy would be required to implement a 30-minute clearance period of the clearance zones (Table 34) immediately prior to the commencing of the survey or when there is more than a 30-minute break in survey activities and PSOs have not been actively monitoring. The clearance zones would be monitored by PSOs using the appropriate visual technology. If a marine mammal is observed within a clearance zone during the clearance period, ramp-up (described below) may not begin until the animal(s) has been observed voluntarily exiting its respective clearance zone or until an additional time period has elapsed with no further sighting (*i.e.*, 15 minutes

for small odontocetes and seals, and 30 minutes for all other species). In any case when the clearance process has begun in conditions with good visibility, including via the use of night vision equipment (IR/thermal camera), and the Lead PSO has determined that the clearance zones are clear of marine mammals, survey operations would be allowed to commence (*i.e.*, no delay is required) despite periods of inclement weather and/or loss of daylight.

Once the survey has commenced, Dominion Energy would be required to shut down boomers, sparkers, and CHIRPs if a marine mammal enters a respective shutdown zone (Table 34). In cases when the shutdown zones become obscured for brief periods due to inclement weather, survey operations would be allowed to continue (*i.e.*, no shutdown is required) so long as no marine mammals have been detected. The use of boomers, sparkers, and CHIRPs would not be allowed to commence or resume until the animal(s) has been confirmed to have left the shutdown zone or until a full 15 minutes (for small odontocetes and seals) or 30 minutes (for all other marine mammals) have elapsed with no further sighting. Any large whale sighted by a PSO within 1,000 m of the boomers, sparkers, and CHIRPs that cannot be identified as a non-North Atlantic right whale must be treated as if it were a North Atlantic right whale.

The shutdown requirement would be waived for small delphinids of the following genera: *Delphinus*, *Stenella*, *Lagenorhynchus*, and *Tursiops*. Specifically, if a delphinid from the specified genera is visually detected approaching the vessel (*i.e.*, to bow-ride) or towed equipment, shutdown would not be required. Furthermore, if there is uncertainty regarding identification of a marine mammal species (*i.e.*, whether the observed marine mammal(s) belongs to one of the delphinid genera for which shutdown is waived), the PSOs would use their best professional judgment in making the decision to call for a shutdown. Shutdown would be required if a delphinid that belongs to a genus other than those specified is detected in the shutdown zone.

If a boomer, sparker, or CHIRP is shut down for reasons other than mitigation (*e.g.*, mechanical difficulty) for less than 30 minutes, it would be allowed to be activated again without ramp-up only if (1) PSOs have maintained constant observation, and (2) no additional detections of any marine mammal occurred within the respective shutdown zones. If a boomer, sparker, or CHIRP was shut down for a period longer than 30 minutes, then all clearance and ramp-up procedures would be required, as previously described.

**Table 34 – Distances To The Mitigation Zones During HRG Surveys**

Marine Mammals	HRG Surveys	
	Clearance Zone (m)	Shutdown Zone (m)
North Atlantic right whale - visual detection	500	500
Endangered species (excluding North Atlantic right whales)	500	500
All other marine mammals <sup>a</sup>	100	100

*a - Exceptions are noted for delphinids from genera Delphinus, Lagenorhynchus, Stenella, or Tursiops and seals.*

**Ramp-Up**

At the start or restart of the use of boomers, sparkers, and/or CHIRPs, a ramp-up procedure would be required unless the equipment operates on a binary on/off switch. A ramp-up procedure, involving a gradual increase in source level output, is required at all times as part of the activation of the acoustic source when technically feasible. Operators would ramp up sources to half power for 5 minutes and then proceed to full power. Prior to a ramp-up procedure starting, the operator would have to notify the Lead PSO of the planned start of the ramp-up. This notification time would not be less than 60 minutes prior to the planned ramp-up activities as all relevant PSOs would need the appropriate 30 minute period to monitor prior to the initiation of ramp-up. Prior to ramp-up beginning, the operator must receive confirmation from the PSO that the clearance zone is clear of any marine mammals. All ramp-ups would be scheduled to minimize the overall time spent with the source being activated. The ramp-up procedure must be used at the beginning of HRG survey activities or after more than a 30-minute break in survey activities using the specified HRG equipment to provide additional protection to marine mammals in or near the survey area by allowing them to vacate the area prior to operation of survey equipment at full power.

Dominion Energy would not initiate ramp-up until the clearance process has been completed (see Clearance and Shutdown Zones section above). Ramp-up activities would be delayed if a marine mammal(s) enters its respective clearance zone. Ramp-up would only be reinitiated if the animal(s) has been observed exiting its respective shutdown zone or until additional time has elapsed with no further sighting (*i.e.*, 15 minutes for small odontocetes and seals, and 30 minutes for all other species).

**Fishery Monitoring Surveys**

For all pot/trap surveys, Dominion Energy would implement marine mammal monitoring and gear interaction avoidance measures to ensure no marine mammals are taken (*e.g.*, entangled) during the surveys. Monitoring measures would be implemented based on the Atlantic Large Whale Take Reduction Plan (50 CFR 229.32). All captains and crew conducting the surveys will be trained in marine mammal detection and identification. Dominion Energy and/or its cooperating institutions, contracted vessels, or commercially-hired captains must implement the following “move-on” rule. If marine mammals are sighted within 1 nm of the planned location in the 15 minutes before gear deployment, Dominion Energy and/or its cooperating institutions, contracted vessels, or commercially-hired captains, as appropriate, may decide to move the vessel away from the marine mammal to a different section of the sampling area if the animal appears to be at risk of interaction with the gear, based on best professional judgment. If, after moving on, marine mammals are still visible from the vessel, Dominion Energy and/or its cooperating institutions, contracted vessels, or commercially-hired captains may decide to move again or to skip the station. Gear would not be deployed if marine mammals are observed within the area and if a marine mammal is deemed to be at risk of interaction, all gear will be immediately removed. Dominion Energy and/or its cooperating institutions must deploy pot gear as soon as is practicable upon arrival at the sampling station. Dominion Energy and/or its cooperating institutions must initiate marine mammal watches (visual observation) no less than 15 minutes prior to both deployment and retrieval of the pot gear. Marine mammal watches must be conducted by scanning these surrounding waters with the naked eye and binoculars and monitoring effort must be maintained during the entire period of the time that gear is in the water (*i.e.*, throughout gear deployment, fishing, and retrieval).

If marine mammals are sighted near the vessel during the soak and are determined to be at risk of interacting with the gear, then Dominion Energy and/or its cooperating institutions, contracted vessels, or commercially-hired captains must immediately and carefully retrieve the gear as quickly as possible. Dominion Energy and/or its cooperating institutions, contracted vessels, or commercially-hired captains may use best professional judgment in making this decision. Dominion Energy and/or its cooperating institutions, contracted vessels, or commercially-hired captains must ensure that surveys deploy gear fulfilling all pot universal commercial gear configurations such as weak link requirements and marking requirements as specified by applicable take

reduction plans as required for commercial pot fisheries. Dominion Energy will be using on-demand fishing systems aimed at reducing the entanglement risk to protected species. These systems include, but are not limited to, spooled systems, buoy and stowed systems, lift bag systems, and grappling. All gear must be clearly labeled as attributed to Dominion Energy's fishery surveys. All fisheries monitoring gear must be fully cleaned and repaired (if damaged) before each use. Any lost gear associated with the fishery surveys will be reported to the NOAA Greater Atlantic Regional Fisheries Office Protected Resources Division (*nmfs.gar.incidental-take@noaa.gov*) as soon as possible or within 24 hours of the documented time of missing or lost gear. This report must include information on any markings on the gear and any efforts undertaken or planned to recover the gear. Finally, all survey vessels will adhere to all vessel mitigation measures (see the **Proposed Mitigation** section).

Based on our evaluation of the applicant's proposed measures, as well as other measures considered by NMFS, NMFS has preliminarily determined that the proposed mitigation measures would provide the means of affecting the least practicable impact on the affected species or stocks and their habitat, paying particular attention to rookeries, mating grounds, and areas of similar significance.

### **Proposed Monitoring and Reporting**

In order to promulgate a rulemaking for an activity, section 101(a)(5)(A) of the MMPA states that NMFS must set forth requirements pertaining to the monitoring and reporting of such taking. The MMPA implementing regulations at 50 CFR 216.104(a)(13) indicate that requests for authorizations must include the suggested means of accomplishing the necessary monitoring and reporting that will result in increased knowledge of the species and of the level of taking or impacts on populations of marine mammals that are expected to be present in the proposed action area. Effective reporting is critical both to compliance as well as ensuring that the most value is obtained from the required monitoring.

Monitoring and reporting requirements prescribed by NMFS should contribute to improved understanding of one or more of the following:

- Occurrence of marine mammal species or stocks in the area in which take is anticipated (*e.g.*, presence, abundance, distribution, density);
- Nature, scope, or context of likely marine mammal exposure to potential stressors/impacts (individual or cumulative, acute or chronic), through better understanding of: (1) action or environment (*e.g.*, source characterization, propagation, ambient noise); (2) affected species (*e.g.*, life history, dive patterns); (3) co-occurrence of marine mammal species with the action; or (4) biological or behavioral context of exposure (*e.g.*, age, calving or feeding areas);
- Individual marine mammal responses (behavioral or physiological) to acoustic stressors (acute, chronic, or cumulative), other stressors, or cumulative impacts from multiple stressors;
- How anticipated responses to stressors impact either: (1) long-term fitness and survival of individual marine mammals; or (2) populations, species, or stocks;
- Effects on marine mammal habitat (*e.g.*, marine mammal prey species, acoustic habitat, or other important physical components of marine mammal habitat); and/or
- Mitigation and monitoring effectiveness.

Separately, monitoring is also regularly used to support mitigation implementation, which is referred to as mitigation monitoring, and monitoring plans typically include measures that both support mitigation implementation and increase our understanding of the impacts of the activity on marine mammals.

During Dominion Energy's construction activities, visual monitoring by NMFS-approved PSOs would be conducted before, during, and after impact pile driving, vibratory pile driving, and HRG surveys. PAM would also be conducted during all impact pile driving. Observations and acoustic detections by PSOs would be used to support the activity-specific mitigation measures described above. Also, to increase understanding of the impacts of the activity on marine mammals, observers would record all incidents of marine mammal occurrence

at any distance from the vibratory/impact piling and during active HRG acoustic sources, and monitors would document all behaviors and behavioral changes, in concert with distance from an acoustic source. The required monitoring is described below, beginning with PSO measures that are applicable to all activities or monitoring and followed by activity-specific monitoring requirements.

Again, we specify here that although the language contained in this proposed rule directly refers to the applicant, Dominion Energy, all proposed measures discussed herein would also apply to any contractors or other agents working for Dominion Energy specific to the CVOW-C project.

### **PSO and PAM Operator Requirements**

Dominion Energy would be required to collect sighting, behavioral response, and acoustic data related to construction activities for marine mammal species observed in the region of the activity during the period in which the activities occur using NMFS-approved visual PSOs and acoustic PAM operators (see **Proposed Mitigation** section). All observers must be trained in marine mammal identification and behaviors and are required to have no other construction-related tasks while conducting monitoring. PSOs would monitor all clearance and shutdown zones prior to, during, and following impact pile driving, vibratory pile driving, and during HRG surveys using boomers, sparkers, and CHIRPs (with monitoring durations specified further below). PSOs will also monitor the Level B harassment zones to the extent practicable (noting that some zones are too large to fully observe) and beyond and will document any marine mammals observed. Observers would be located at the best practicable vantage points on the pile driving vessel and, where required, on an aerial platform. Full details regarding all marine mammal monitoring must be included in relevant Plans (*e.g.*, Pile Driving and Marine Mammal Monitoring Plan) that, under this proposed action, Dominion Energy would be required to submit to NMFS for approval at least 180 days in advance of the commencement of any construction activities.

The following measures apply to all visual monitoring efforts:

1. Monitoring must be conducted by NMFS-approved, trained PSOs and PAM operators. PSOs must be placed at the primary location relevant to the activity (*i.e.*, pile driving vessel, HRG survey vessel) and on any necessary dedicated PSO vessels (*e.g.*, additional pile driving vessel(s), if required). PSOs must be in the best vantage point(s) position in order to ensure 360° visual coverage of the entire clearance and shutdown zones, around the observing platform and as much of the Level B harassment zone as possible while still maintaining a safe work environment;
2. PSO and PAM operators must be independent third-party observers and must have no tasks other than to conduct observational effort, collect data, and communicate with and instruct the relevant vessel crew with regard to the presence of protected species and mitigation requirements;
3. PSOs may not exceed 4 consecutive watch hours, must have a minimum 2-hour break between watches, and may not exceed a combined watch schedule of more than 12 hours in a single 24-hour period;
4. PSOs would be required to use appropriate equipment (specified below) to monitor for marine mammals. During periods of low visibility (*e.g.*, darkness, rain, fog, poor weather conditions, *etc.*), PSOs would be required to use alternative technologies (*i.e.*, infrared or thermal cameras) to monitor the shutdown and clearance zones; and
5. PSOs must be in the best vantage point to monitor for marine mammals and implement the relevant clearance and shutdown procedures, when determined to be applicable.
6. PSOs should have the following minimum qualifications:
  - a. Visual acuity in both eyes (corrected is permissible) sufficient for discernment of moving targets at the water's surface with the ability to estimate the target size and distance. The use of binoculars is permitted and may be necessary to correctly identify the target(s);

- b. Ability to conduct field observations and collect data according to the assigned protocols;
- c. Sufficient training, orientation, or experience with the construction operation to provide for personal safety during observations;
- d. Writing skills sufficient to document observations, including but not limited to: the number and species of marine mammals observed, the dates and times of when in-water construction activities were conducted, the dates and time when in-water construction activities were suspended to avoid potential incidental injury of marine mammals from construction noise within a defined shutdown zone, and marine mammal behavior; and
- e. Ability to communicate orally, by radio, or in-person, with project personnel to provide real-time information on marine mammals observed in the area, as necessary.

Observer teams employed by Dominion Energy, in satisfaction of the mitigation and monitoring requirements described herein, must meet the following additional requirements:

7. PSOs must successfully complete relevant training, including completion of all required coursework and a written and/or oral examination developed for the training;
8. PSOs must have successfully attained a bachelor's degree from an accredited college or university with a major in one of the natural sciences, a minimum of 30 semester hours or equivalent in the biological sciences, and at least one undergraduate course in math or statistics. The educational requirements may be waived if the PSO has acquired the relevant skills through alternate experience. Requests for such a waiver shall be submitted to NMFS and must include written justification. Alternate experience that may be considered includes, but is not limited to: Secondary education and/or experience comparable to PSO duties; previous work experience conducting academic, commercial, or government sponsored marine mammal surveys; or previous work experience as a PSO; the PSO should demonstrate good standing and consistently good performance of PSO duties;
9. One observer will be designated as lead observer or monitoring coordinator ("Lead PSO"). This Lead PSO would be required to have a minimum of 90 days of at-sea experience working in this role in an offshore environment and would be required to have no more than eighteen months elapsed since the conclusion of their last at-sea experience;
10. At least one PSO located on platforms (either vessel-based or aerial) would be required to have a minimum of 90 days of at-sea experience working in this role in an offshore environment and would be required to have no more than eighteen months elapsed since the conclusion of their last at-sea experience; and
11. All PSOs and PAM operators must be approved by NMFS. Dominion Energy would be required to submit resumes of the initial set of PSOs necessary to commence the project to NMFS Office of Protected Resources (OPR) for approval at least 60 days prior to the first day of in-water construction activities requiring PSOs. Resumes would need to include the dates of training and any prior NMFS approval as well as the dates and description of their last PSO experience and must be accompanied by information documenting their successful completion of an acceptable training course. NMFS would allow three weeks to approve PSOs from the time that the necessary information is received by NMFS after which any PSOs that meet the minimum requirements would automatically be considered approved.

Some Dominion Energy activities may require the use of PAM, which would necessitate the employment of at least one PAM operator on duty at any given time. PAM operators would be required to meet several of the specified requirements described above for PSOs, including: 2, 4, 6b-e, 8, 9, 10, and 11. Furthermore, PAM operators would be required to complete a specialized training for operating PAM systems and must demonstrate familiarity with the PAM system on which they would be working.



PSOs would be able to act as both acoustic and visual observers for the project if the individual(s) demonstrates that they have had the required level and appropriate training and experience to perform each task. However, a single individual would not be allowed to concurrently act in both roles or exceed work hours, as specified in #4 above.

Dominion Energy's personnel and PSOs would also be required to use available sources of information on North Atlantic right whale presence to aid in monitoring efforts. This includes:

1. Daily monitoring of the Right Whale Sightings Advisory System;
2. Consulting of the WhaleAlert app; and,
3. Monitoring of the Coast Guard's VHF Channel 16 throughout the day to receive notifications of any sightings and information associated with any Dynamic Management Areas to plan construction activities and vessel routes, if practicable, to minimize the potential for co-occurrence with North Atlantic right whales.

Additionally, whenever multiple project-associated vessels (of any size; *e.g.*, construction survey, crew transfer) are operating concurrently, any visual observations of ESA-listed marine mammals must be communicated to PSOs and vessel captains associated with other vessels to increase situational awareness.

The following are proposed monitoring and reporting measures that NMFS would require specific to each construction activity:

#### **WTG and OSS Foundation Installation**

Dominion Energy would be required to implement the following monitoring procedures during all impact pile driving of WTG and OSS foundations.

During all observations associated with pile driving (vibratory and/or impact), PSOs would use magnification (7x) binoculars and the naked eye to search continuously for marine mammals. At least one PSO would be located on the foundation pile driving vessel and a secondary dedicated-PSO vessel. These PSOs must be equipped with Big Eye binoculars (*e.g.*, 25 x 50; 2,7 view angle; individual ocular focus; height control) of appropriate quality. These would be pedestal-mounted on the deck at the most appropriate vantage point that provides optimal sea surface observation and PSO safety.

Dominion Energy would be required to have a minimum of four PSOs actively observing marine mammals before, during, and after (specific times described below) the installation of foundation piles (monopiles and pin piles for jacket foundations). At least two PSOs must be actively observing on the pile driving vessel while at least two PSOs are actively observing on a secondary, PSO-dedicated vessel. Concurrently, at least one acoustic PSO (*i.e.*, PAM operator) must be actively monitoring for marine mammals before, during and after impact pile driving.

As described in the **Proposed Mitigation** section, if the minimum visibility zone cannot be visually monitored at all times, pile driving operations may not commence or, if active, must shutdown, unless Dominion Energy determines shutdown is not practicable due to imminent risk of injury or loss of life to an individual, pile refusal, or pile instability.

To supplement visual observation efforts, Dominion Energy would utilize at least one PAM operator before, during, and after pile installation. This PAM operator would assist the PSOs in ensuring full coverage of the clearance and shutdown zones. All on-duty visual PSOs would remain in contact with the on-duty PAM operator, who would monitor the PAM systems for acoustic detections of marine mammals in the area. In some cases, the PAM operator and workstation may be located onshore or they may be located on a vessel. In either situation, PAM operators would maintain constant and clear communication with visual PSOs on duty regarding detections of marine mammals that are approaching or within the applicable zones related to impact pile driving. Dominion Energy would utilize PAM to acoustically monitor the clearance and shutdown zones (and beyond for situational awareness), and would record all detections of marine mammals and estimated

distance, when possible, to the activity (noting whether they are in the Level A harassment or Level B harassment zones). To effectively utilize PAM, Dominion Energy would implement the following protocols:

- PAM operators would be stationed on at least one of the dedicated monitoring vessels in addition to the PSOs, or located remotely/onshore.
- All PAM operators must be NMFS-approved, third party contractors. PAM operators would have completed specialized training for operating PAM systems prior to the start of monitoring activities, including identification of species-specific mysticete vocalizations (*e.g.*, North Atlantic right whales). The PAM operator must demonstrate that they have prior experience with similar acoustic projects and/or completed specialized training for operating PAM systems and detecting and identifying Atlantic Ocean marine mammals sounds.
- Where localization of sounds or deriving bearings and distance are proposed, the PAM operators need to have demonstrated experience in using this technique.
- PAM operators must demonstrate experience with relevant acoustic software and equipment.
- PAM operators must have the qualifications and relevant experience/training to safely deploy and retrieve equipment and program the software, as necessary.
- PAM operators must be able to test software and hardware functionality prior to operation.
- PAM operators must have evaluated their acoustic detection software using the PAM Atlantic baleen whale annotated data set available through the National Centers for Environmental Information (NCEI; <https://www.ncei.noaa.gov/>) and provide evaluation/performance metric.

The PAM operator(s) on-duty would monitor the PAM systems for acoustic detections of marine mammals that are vocalizing in the area. Any detections would be conveyed to the PSO team and any PSO sightings would be conveyed to the PAM operator for awareness purposes, and to identify if mitigation is to be triggered. For real-time PAM systems, at least one PAM operator would be designated to monitor each system by viewing data or data products that are streamed in real-time or near real-time to a computer workstation and monitor located on a project vessel or onshore. The PAM operator would inform the Lead PSO on duty of marine mammal detections approaching or within applicable ranges of interest to the pile driving activity via the data collection software system (*i.e.*, Mysticetus or similar system), who would be responsible for requesting that the designated crew member implement the necessary mitigation procedures (*i.e.*, delay or shutdown). Acoustic monitoring would complement visual monitoring at all times and would cover an area of at least the Level B harassment zone around each foundation.

All PSOs and PAM operators would be required to begin monitoring 60 minutes prior to and during all impact pile driving and for 30 minutes after impact driving. However, PAM operators must review acoustic data from the previous 24 hours as well. As described in the **Proposed Mitigation** section, pile driving of monopiles and pin piles would only commence when the minimum visibility zone (extending 2.0 km from the pile, based on NMFS' proposed distance) is fully visible (*e.g.*, not obscured by darkness, rain, fog, *etc.*) and the clearance zones are clear of marine mammals for at least 30 minutes, as determined by the Lead PSO, immediately prior to the initiation of impact pile driving.

For North Atlantic right whales, any visual (regardless of distance) or acoustic detection would trigger a delay to the commencement of pile driving. In the event that a large whale is sighted or acoustically detected that cannot be confirmed as a non-North Atlantic right whale species, it must be treated as if it were a North Atlantic right whale. Following a shutdown, monopile/pin pile installation may not recommence until the minimum

visibility zone is fully visible and the clearance zone is clear of marine mammals for 30 minutes and no marine mammals have been detected acoustically within the PAM clearance zone for 30 minutes.

During the time period in which Dominion Energy would be allowed to pile driving (May 1- October 31), North Atlantic right whales are most likely to occur in May. Dominion Energy has proposed additional enhanced monitoring measures to supplement PSO and PAM operators during the month of May (per the May Pile Driving Memo Dominion Energy submitted to NMFS on March 23, 2023 and which can be found on NMFS' website), including the use of drones equipped with infrared technology (referred to as autonomous vehicles, remote operated vehicles in Dominion Energy's PSMMP), additional PSO vessels on-site, aerial surveys, and/or 24-hour PAM use. These measures, as proposed by Dominion Energy, would not prevent or replace other proposed monitoring measures (*i.e.*, PSOs and/or PAM operators). Instead, these additional measures would serve to complement and strengthen other monitoring approaches. Dominion Energy would seek to use autonomous or remotely operated vehicles (*i.e.*, drones) that may use infrared technology; then the use of additional PSOs for enhanced coverage; and then aerial surveys. While Dominion Energy proposed these measures, they have not committed to implementing these measures in order to proceed with foundation installation in May. Hence, NMFS is not proposing to require them here. However, we describe requirements for drone use below in the case that Dominion Energy does employ drones in addition to the previously described PSO and acoustic monitoring requirements.

If drones are deployed during May foundation installation activities Dominion Energy would undertake monitoring approaches in a way that would ensure no additional behavioral harassment or impacts on marine mammals would occur. While specifics on Dominion Energy's drone strategy was not provided in either the ITA application, nor the PSMMP, given ongoing and planned testing to occur in 2023, NMFS would require that:

- All drone operators and associated drone crews would be fully trained, qualified, and would operate in compliance with current Federal Aviation Administration (FAA), Federal, State, and local standards and would be operated in accordance with 14 CFR part 107 (Small Unmanned Aircraft Systems, Docket FAA-2015-0150, Amdt. 107-1, 81 FR 42209, June 28, 2016, unless otherwise noted);
- An appropriate number of drone operators and crews would be utilized, with some personnel operating the drone and others monitoring the instrumentation for marine mammal identification in real-time (*i.e.*, would be trained and certified PSOs);
- All monitoring crews (*i.e.*, PSOs operating drones) would meet the requirements and qualifications previously described in this proposed rulemaking;
- All drones would maintain appropriate altitudes and minimize maneuvers or circling activities that may incur behavioral harassment to marine mammals and appropriate distances (to be decided based on the 2023 testing by Dominion Energy) would be required if mothers and calves are sighted; and
- All drone visual observations would be incorporated into the standard reporting requirements, described later on in this proposed rulemaking.

The advancement of additional monitoring measures have the potential to enhance capabilities in situations where there is limited visibility. However, implementation of such strategies would require additional testing by Dominion Energy (via 2023 trials) and additional discussions between NMFS.

For all foundation installation activities, Dominion Energy must prepare and submit a Pile Driving and Marine Mammal Monitoring Plan (including information related to the proposed enhanced monitoring measures described above) to NMFS for review and approval at least 180 days before the start of any pile driving. The plans must include final pile driving project design (*e.g.*, number and type of piles, hammer type, noise

abatement systems, anticipated start date, *etc.*) and all information related to PAM PSO monitoring protocols for pile-driving and visual PSO protocols for all activities.

#### **Cable Landfall Activities - Temporary Cofferdams**

Dominion Energy would be required to implement the following procedures during all vibratory pile driving activities associated with the installation and removal of temporary cofferdams.

During all observation periods related to vibratory pile driving, PSOs must use standard handheld (7x) binoculars and the naked eye to search continuously for marine mammals. Dominion Energy would be required to have a minimum of two PSOs on active duty during any installation and removal activities related to temporary cofferdams. These PSOs would always be located at the best vantage point(s) on the vibratory pile driving platform or secondary platform in the immediate vicinity of the primary platforms in order to ensure that appropriate visual coverage is available of the entire visual clearance zone and as much of the Level B harassment zone as possible. NMFS would not require the use of PAM for these activities.

PSOs would monitor the clearance zone for the presence of marine mammals for 30 minutes before, throughout the installation of the piles, and for 30 minutes after the activities have ceased. Installation may only commence when visual clearance zones are fully visible (*e.g.*, not obscured by darkness, rain, fog, *etc.*) and clear of marine mammals, as determined by the Lead PSO, for at least 30 minutes immediately prior to initiation of vibratory pile driving.

#### **Cable Landfall Activities - Temporary Goal Posts**

Dominion Energy would be required to implement the following procedures during all impact pile driving activities associated with the installation of temporary goal posts. These requirements generally mirror the requirements described above for temporary cofferdams.

During all observation periods related to impact pile driving, PSOs must use standard handheld (7x) binoculars and the naked eye to search continuously for marine mammals. Dominion Energy would be required to have a minimum of two PSOs on active duty during any installation activities related to temporary goal posts. These PSOs would always be located at the best vantage point(s) on the impact pile driving platform or secondary platform in the immediate vicinity of the primary platforms in order to ensure that appropriate visual coverage is available of the entire visual clearance zone and as much of the Level B harassment zone as possible. NMFS would not require the use of PAM for these activities.

PSOs would monitor the clearance zone for the presence of marine mammals for 30 minutes before, throughout the installation of the pipe piles, and for 30 minutes after the activities have ceased. Installation may only commence when visual clearance zones are fully visible (*e.g.*, not obscured by darkness, rain, fog, *etc.*) and clear of marine mammals, as determined by the Lead PSO, for at least 30 minutes immediately prior to initiation of impact pile driving.

#### **HRG Surveys**

Dominion Energy would be required to implement the following procedures during all HRG surveys.

During all observation periods, PSOs must use standard handheld (7x) binoculars and the naked eye to search continuously for marine mammals.

Between four and six PSOs would be present on every 24-hour survey vessel, and two to three PSOs would be present on every 12-hour survey vessel. Dominion Energy would be required to have at least one PSO on active duty during HRG surveys that are conducted during daylight hours (*i.e.*, from 30 minutes prior to sunrise through 30 minutes following sunset) and at least two PSOs during HRG surveys that are conducted during nighttime hours.

All PSOs would begin monitoring 30 minutes prior to the activation of boomers, sparkers, or CHIRPs; throughout use of these acoustic sources, and for 30 minutes after the use of the acoustic sources has ceased. Given that multiple HRG vessels may be operating concurrently, any observations of marine mammals would be required to be communicated to PSOs on all nearby survey vessels.

Ramp-up of boomers, sparkers, and CHIRPs would only commence when visual clearance zones are fully visible (*e.g.*, not obscured by darkness, rain, fog, *etc.*) and clear of marine mammals, as determined by the Lead PSO, for at least 30 minutes immediately prior to initiation of survey activities utilizing the specified acoustic sources.

During daylight hours when survey equipment is not operating, Dominion Energy would ensure that visual PSOs conduct, as rotation schedules allow, observations for comparison of sighting rates and behavior with and without use of the specified acoustic sources. Off-effort PSO monitoring must be reflected in the monthly PSO monitoring reports.

### **Marine Mammal Passive Acoustic Monitoring**

As described previously, Dominion Energy would be required to utilize a PAM system to supplement visual monitoring for all foundation installation activities, inclusive of vibratory and impact hammer installation. Training and qualified PAM operators would monitor the PAM systems. PAM operators may be on watch for a maximum of four consecutive hours followed by a break of at least two hours between watches. Again, PSOs can act as PAM operators or visual PSOs (but not simultaneously) as long as they demonstrate that their training and experience are sufficient to perform each task. The PAM system must be monitored by a minimum of one PAM operator beginning at least 60 minutes prior to the initiation of soft-start of foundation piles, at all times during installation, and for 30 minutes after pile driving has ceased. To further aid in detections of North Atlantic right whales during the highest occurrence month (May) during the construction period (and as described above for monitoring during *WTG and OSS foundation Installation*), PAM would be implemented 24-hours prior to foundation activities.

PAM operators would monitor the signals from the hydrophones in both real-time using headphones and visually via the outputs on a computer monitor. PAM operators must immediately communicate all detections of marine mammals at any distance (*i.e.*, not limited to the Level B harassment zones) to visual PSOs, including any determination regarding species identification, distance, and bearing and the degree of confidence in the determination. Based on the information provided by the PAM operator, the Lead PSO on duty would ensure that the appropriate mitigation measures are implemented, if determined to be necessary. A PAM detection alone, even without a visual confirmation that a marine mammal is within a relevant clearance and/or shutdown zone, would trigger mitigation measures, such as a delay or the shutdown of pile driving activities (if safe to do so). Additionally, PAM detections of North Atlantic right whales, even without a visual detection, would trigger the appropriate mitigation measures.

PAM systems may be used for real-time mitigation monitoring. The PAM system would be, at a minimum, capable of detecting animals at least 5 km away from the pile driving location. The PAM system would offer real-time detections of low-frequency cetaceans with a targeted frequency range of 20 Hz to 1,500 Hz, with a specific focus on a system capable of monitoring the bandwidth for North Atlantic right whales (65-400 Hz; corresponding to information provided in Van Parijs *et al.* (2021)). The requirement for real-time detection and localization limits the types of PAM technologies that can be used to those systems that are either cabled, satellite, or radio-linked. It is most likely that Dominion Energy would deploy fixed surface buoys and/or gliding autonomous vehicle PAM devices. The system chosen will dictate the design and protocols of the PAM operations. Dominion Energy is not considering bottom-mounted, fixed cabled PAM systems, in part due to the ability of most of these systems to record data archivally rather than in real-time or near-real-time. Towed systems, while being considered, are not preferred as they could be easily masked by vessel noise. For a review of the PAM systems Dominion Energy is considering, see section 7.3 and 7.4 of the PSMMP included as a supplement to Dominion Energy's ITA application.

At this stage, Dominion Energy has not chosen the appropriate and final PAM systems for the CVOW-C project. However, when an appropriate system or configuration of systems is chosen, a Passive Acoustic Monitoring (PAM) Plan must be submitted to NMFS for review and approval at least 180 days prior to the

planned start of foundation installations. PAM should follow standardized measurement, processing methods, reporting metrics, and metadata standards for offshore wind (Van Parijs *et al.*, 2021). The plan must describe all proposed PAM equipment, procedures, and protocols. However, NMFS considers PAM usage for every project on a case-by-case basis and would continue discussions with Dominion Energy regarding selection of the PAM system that is most appropriate for the proposed project. The authorization to take marine mammals would be contingent upon NMFS' approval of the PAM Plan.

#### **Acoustic Monitoring for Sound Field and Harassment Isoleth Verification (SFV)**

During the installation (inclusive of both vibratory and impact pile driving approaches) of the first three WTG monopile foundations and all three OSSs using jacket foundations, Dominion Energy must empirically determine source levels, the ranges to the isopleths corresponding to the Level A harassment and Level B harassment thresholds, and the transmission loss coefficient(s). Dominion Energy may also estimate ranges to the Level A harassment and Level B harassment isopleths by extrapolating from *in situ* measurements conducted at several distances from the monopile and pin piles in each OSS being driven. Dominion Energy must measure received levels at a standard distance of 750 m from the monopile and pin piles in each OSS and at both the presumed modeled Level A harassment and Level B harassment isopleth ranges or an alternative distance(s) as agreed to in the SFV Plan. In addition to the 750 m distance, Dominion Energy has also proposed to monitor at 2,500 m and 5,000 m from the pile, as well as the extent of the modeled Level B harassment zone to verify the accuracy of the modeled zones.

If acoustic field measurements collected during installation of the WTG monopiles and OSS foundations indicates ranges to the isopleths corresponding to Level A harassment and Level B harassment thresholds are greater than the ranges predicted by modeling (assuming 10-dB attenuation), Dominion Energy must implement additional noise attenuation measures prior to installing the next WTG monopile or OSS jacket foundation. Dominion Energy has also proposed to monitor and collect acoustic information on a subsequent monopile in the event that obtained technical information indicates a monopile would produce a larger sound field than previously monitored. Initial additional measures may include improving the efficacy of the implemented noise mitigation technology (*e.g.*, BBC, dBBC) and/or modifying the piling schedule to reduce the sound source. Each sequential modification would be evaluated empirically by acoustic field measurements. In the event that field measurements indicate ranges to isopleths corresponding to Level A harassment and Level B harassment thresholds are greater than the ranges predicted by modeling (assuming 10-dB attenuation), NMFS may expand the relevant harassment, clearance, and shutdown zones and associated monitoring protocols. If harassment zones are expanded beyond an additional 1,500 m, additional PSOs would be deployed on additional platforms with each observer responsible for maintaining watch in no more than 180° and of an area with a radius no greater than 1,500 m.

If acoustic measurements indicate that ranges to isopleths corresponding to the Level A harassment and Level B harassment thresholds are less than the ranges predicted by modeling (assuming 10-dB attenuation), Dominion Energy may request a modification of the clearance and shutdown zones for pile driving of WTG monopiles and OSS foundation pin piles. For NMFS to consider a modification request, Dominion Energy will have had to conduct SFV on three or more WTG monopiles and two full OSS jacket foundations (8 total pin piles), thus far, to verify that zone sizes are consistently smaller than those predicted by modeling (assuming 10-dB attenuation). In addition, if a subsequent monopile installation location is selected that was not represented by previous three locations (*i.e.*, substrate composition, water depth), SFV would be required. Furthermore, if pile driving of WTG foundations occurs across different seasons from the season the first monopile was installed in (*i.e.*, the first monopile was driven in the spring and as pile driving would also occur in the fall, acoustic measurements for the pile driven in the fall would also be required to occur), Dominion Energy has proposed, for comparison, to collect acoustic measurements on these piles as well.

Upon receipt of an interim SFV report, NMFS may adjust zones (*i.e.*, Level A harassment, Level B harassment, clearance, shutdown, and/or minimum visibility zone) to reflect SFV measurements. The shutdown and clearance zones for pile driving would be equivalent to the measured range to the Level A harassment isopleth plus 10% (shutdown zone) and 20% (clearance zone), rounded up to the nearest 100 m for PSO clarity. The minimum visibility zone would be based on the largest measured distance to the Level A harassment isopleth for large whales. Regardless of SFV, a North Atlantic right whale detected at any distance by PSOs would continue to result in a delay to the start of pile driving. Similarly, if pile driving has commenced, shutdown would be called for in the event a North Atlantic right whale is observed at any distance. That is, the visual clearance and shutdown criteria for North Atlantic right whales would not change, regardless of field acoustic measurements. The Level B harassment zone would be equal to the largest measured range to the Level B harassment isopleth.

The SFV plan must also include how operational noise from the wind farm would be monitored. Dominion Energy would be required to estimate source levels based on measurements in the near and far-field at a minimum of three locations from each foundation monitored. These data must be used to also identify estimated transmission loss rates. Operational parameters (*e.g.*, direct drive/gearbox information, turbine rotation rate) as well as sea state conditions and information on nearby anthropogenic activities (*e.g.*, vessels transiting or operating in the area) must be reported.

Dominion Energy must submit a SFV Plan at least 180 days prior to the planned start of impact pile driving activities. The plan must describe how Dominion Energy would ensure that the first three WTG monopile and OSS jacket (using pin piles) foundation installation sites selected for SFV are representative of the rest of the monopile and pin pile installation sites. Dominion Energy must include information on how additional sites/scenarios would be selected for SFV should it be determined that these sites/scenarios are not representative of all other monopile installation sites. The plan must also include the methodology for collecting, analyzing, and preparing SFV data for submission to NMFS. The plan must describe how the effectiveness of the sound attenuation methodology would be evaluated based on the results. Dominion Energy must also provide, as soon as they are available but no later than 48 hours after each installation, the initial results of the SFV measurements to NMFS in an interim report after each monopile for the first three piles.

### **Reporting**

Prior to any construction activities occurring, Dominion Energy would provide a report to NMFS (at [itp.potlock@noaa.gov](mailto:itp.potlock@noaa.gov) and [pr.itp.monitoringreports@noaa.gov](mailto:pr.itp.monitoringreports@noaa.gov)) documenting that all required training for Dominion Energy personnel (*i.e.*, vessel crews, vessel captains, PSOs, and PAM operators) has been completed. Dominion Energy has also proposed to contact both BOEM and NMFS within 24-hour of the commencement of pile driving activities for the year and again within 24 hours of the completion of the pile driving activities for that year (based on May 1<sup>st</sup> through October 31<sup>st</sup>).

NMFS would require standardized and frequent reporting from Dominion Energy during the life of the proposed regulations and LOA. All data collected relating to the Dominion Energy project would be recorded using industry-standard software (*e.g.*, Mysticetus or a similar software) installed on field laptops and/or tablets. Dominion Energy would be required to submit weekly, monthly and annual reports as described below. During activities requiring PSOs, the following information would be collected and reported related to the activity being conducted:

- Date and time that monitored activity begins or ends;
- Construction activities occurring during each observation period;
- Watch status (*i.e.*, sighting made by PSO on/off effort, opportunistic, crew, alternate vessel/platform);
- PSO who sighted the animal;
- Time of sighting;

- Weather parameters (*e.g.*, wind speed, percent cloud cover, visibility);
- Water conditions (*e.g.*, sea state, tide state, water depth);
- All marine mammal sightings, regardless of distance from the construction activity;
- Species (or lowest possible taxonomic level possible);
- Pace of the animal(s);
- Estimated number of animals (minimum/maximum/high/low/best);
- Estimated number of animals by cohort (*e.g.*, adults, yearlings, juveniles, calves, group composition, *etc.*);
- Description (*i.e.*, as many distinguishing features as possible of each individual seen, including length, shape, color, pattern, scars or markings, shape and size of dorsal fin, shape of head, and blow characteristics);
- Description of any marine mammal behavioral observations (*e.g.*, observed behaviors such as feeding or traveling) and observed changes in behavior, including an assessment of behavioral responses thought to have resulted from the specific activity;
- Animal's closest distance and bearing from the pile being driven or specified HRG equipment and estimated time spent within the Level A harassment and/or Level B harassment zones;
- Construction activity at time of sighting (*e.g.*, vibratory installation/removal, impact pile driving, HRG survey), use of any noise abatement device(s), and specific phase of activity (*e.g.*, ramp-up of HRG equipment, HRG acoustic source on/off, soft-start for pile driving, active pile driving, *etc.*);
- Description of any mitigation-related action implemented, or mitigation-related actions called for but not implemented, in response to the sighting (*e.g.*, delay, shutdown, *etc.*) and time and location of the action; and
- Other human activity in the area.

For all real-time acoustic detections of marine mammals, the following must be recorded and included in weekly, monthly, annual, and final reports:

1. Location of hydrophone (latitude & longitude; in Decimal Degrees) and site name;
2. Bottom depth and depth of recording unit (in meters);
3. Recorder (model & manufacturer) and platform type (*i.e.*, bottom-mounted, electric glider, *etc.*), and instrument ID of the hydrophone and recording platform (if applicable);
4. Time zone for sound files and recorded date/times in data and metadata (in relation to Universal Coordinated Time (UTC); *i.e.*, Eastern Standard Time (EST) time zone is UTC-5);
5. Duration of recordings (start/end dates and times; in ISO 8601 format, yyyy-mm-ddTHH:MM:SS.sssZ);
6. Deployment/retrieval dates and times (in ISO 8601 format);
7. Recording schedule (must be continuous);
8. Hydrophone and recorder sensitivity (in dB *re. 1 μPa*);
9. Calibration curve for each recorder;
10. Bandwidth/sampling rate (in Hz);
11. Sample bit-rate of recordings; and
12. Detection range of equipment for relevant frequency bands (in meters).

For each detection the following information must be noted:



13. Species identification (if possible);
14. Call type and number of calls (if known);
15. Temporal aspects of vocalization (date, time, duration, *etc.*, date times in ISO 8601 format);
16. Confidence of detection (detected, or possibly detected);
17. Comparison with any concurrent visual sightings;
18. Location and/or directionality of call (if determined) relative to acoustic recorder or construction activities;
19. Location of recorder and construction activities at time of call;
20. Name and version of detection or sound analysis software used, with protocol reference;
21. Minimum and maximum frequencies viewed/monitored/used in detection (in Hz); and
22. Name of PAM operator(s) on duty.

If a North Atlantic right whale is detected, data shall be submitted to *nmfs.pacmdata@noaa.gov* using the NMFS Passive Acoustic Reporting System Metadata and Detection data spreadsheets (<https://www.fisheries.noaa.gov/resource/document/passive-acoustic-reporting-system-templates>) as soon as feasible but no longer than 24 hours after the detection. Submit the completed data templates to *nmfs.pacmdata@noaa.gov*. The full acoustic species Detection data, Metadata and GPS data records, from real-time data, must be submitted within 90 days via the ISO standard metadata forms available on the NMFS Passive Acoustic Reporting System website (<https://www.fisheries.noaa.gov/resource/document/passive-acoustic-reporting-system-template>). Submit the completed data templates to *nmfs.pacmdata@noaa.gov*. Full detection data and metadata must be submitted monthly on the 15<sup>th</sup> of every month for the previous month via the webform on the NMFS North Atlantic right whale Passive Acoustic Reporting System website (<https://www.fisheries.noaa.gov/resource/document/passive-acoustic-reporting-system-templates>).

If a North Atlantic right whale is observed at any time by PSOs or personnel on or in the vicinity of any impact or vibratory pile-driving vessel, dedicated PSO vessel, construction survey vessel, or during vessel transit, Dominion Energy must immediately report sighting information to the NMFS North Atlantic Right Whale Sighting Advisory System (866) 755-6622, to the U.S. Coast Guard via channel 16, and through the WhaleAlert app (<https://www.whalealert.org/>) as soon as feasible but no longer than 24 hours after the sighting. Information reported must include, at a minimum: time of sighting, location, and number of North Atlantic right whales observed.

*SFV Interim Report* - Dominion Energy would be required to provide, as soon as they are available but no later than 48 hours after each installation, the initial results of SFV measurements to NMFS in an interim report after each monopile for the first three piles and any subsequent piles monitored.

*Weekly Report* - Dominion Energy would be required to compile and submit weekly PSO, PAM, and SFV reports to NMFS (*PR.ITP.monitoringreports@noaa.gov*) that document the daily start and stop of all pile driving or HRG survey activities, the start and stop of associated observation periods by PSOs, details on the deployment of PSOs, a record of all detections of marine mammals (acoustic and visual), any mitigation actions (or if mitigation actions could not be taken, provide reasons why), and details on the noise abatement system(s) used and its performance. Weekly reports would be due on Wednesday for the previous week (Sunday – Saturday). The weekly report would also identify which turbines become operational and when (a map must be provided). Once all foundation pile installation is complete, weekly reports would no longer be required.

*Monthly Report* - Dominion Energy would be required to compile and submit monthly reports to NMFS (at *itp.potlock@noaa.gov* and *PR.ITP.monitoringreports@noaa.gov*) that include a summary of all information in the weekly reports, including project activities carried out in the previous month, vessel transits (number, type

of vessel, and route), number of piles installed, all detections of marine mammals, and any mitigative actions taken. Monthly reports would be due on the 15<sup>th</sup> of the month for the previous month. The monthly report would also identify which turbines become operational and when (a map must be provided). Once foundation pile installation is complete, monthly reports would no longer be required.

*Annual Report* - Dominion Energy would be required to submit an annual PSO, PAM, and SFV summary report to NMFS (at [itp.potlock@noaa.gov](mailto:itp.potlock@noaa.gov) and [PR.ITP.monitoringreports@noaa.gov](mailto:PR.ITP.monitoringreports@noaa.gov)) no later than 90 days following the end of a given calendar year describing, in detail, all of the information required in the monitoring section above. A final annual report would be prepared and submitted within 30 calendar days following receipt of any NMFS comments on the draft report. If no comments were received from NMFS within 60 calendar days of NMFS' receipt of the draft report, the report would be considered final.

*Final Report* - Dominion Energy must submit its draft final report(s) to NMFS (at [itp.potlock@noaa.gov](mailto:itp.potlock@noaa.gov) and [PR.ITP.monitoringreports@noaa.gov](mailto:PR.ITP.monitoringreports@noaa.gov)) on all visual and acoustic monitoring conducted under the LOA within 90 calendar days of the completion of activities occurring under the LOA. A final report must be prepared and submitted within 30 calendar days following receipt of any NMFS comments on the draft report. If no comments are received from NMFS within 30 calendar days of NMFS' receipt of the draft report, the report shall be considered final.

### **Situational Reporting**

Specific situations encountered during the development of the Dominion Energy project would require reporting. These situations and the relevant procedures include:

- If a large whale is detected during vessel transit, the following information must be recorded and reported:
  - a. Time, date, and location;
  - b. The vessel's activity, heading, and speed;
  - c. Sea state, water depth, and visibility;
  - d. Marine mammal identification to the best of the observer's ability (e.g., North Atlantic right whale, whale, dolphin, seal);
  - e. Initial distance and bearing to marine mammal from vessel and closest point of approach; and,
  - f. Any avoidance measures taken in response to the marine mammal sighting.
- If a sighting of a stranded, entangled, injured, or dead marine mammal occurs, the sighting would be reported to NMFS OPR, the NMFS Greater Atlantic Regional Fisheries Office (GARFO) Marine Mammal and Sea Turtle Stranding & Entanglement Hotline (866-755-6622), and the U.S. Coast Guard within 24 hours. If the injury or death was caused by a project activity, Dominion Energy must immediately cease all activities until NMFS OPR is able to review the circumstances of the incident and determine what, if any, additional measures are appropriate to ensure compliance with the terms of the LOA. NMFS may impose additional measures to minimize the likelihood of further prohibited take and ensure MMPA compliance. Dominion Energy may not resume their activities until notified by NMFS. The report must include the following information:
  - a. Time, date, and location (latitude/longitude) of the first discovery (and updated location information if known and applicable);
  - b. Species identification (if known) or description of the animal(s) involved;
  - c. Condition of the animal(s) (including carcass condition if the animal is dead);
  - d. Observed behaviors of the animal(s), if alive;
  - e. If available, photographs or video footage of the animal(s); and
  - f. General circumstances under which the animal was discovered.

- In the event of a vessel strike of a marine mammal by any vessel associated with the CVOW-C project, Dominion Energy shall immediately report the strike incident to the NMFS OPR and the GARFO within and no later than 24 hours. Dominion Energy must immediately cease all activities until NMFS OPR is able to review the circumstances of the incident and determine what, if any, additional measures are appropriate to ensure compliance with the terms of the LOA. NMFS may impose additional measures to minimize the likelihood of further prohibited take and ensure MMPA compliance. Dominion Energy may not resume their activities until notified by NMFS. The report must include the following information:
  - a. Time, date, and location (latitude/longitude) of the incident;
  - b. Species identification (if known) or description of the animal(s) involved;
  - c. Vessel's speed during and leading up to the incident;
  - d. Vessel's course/heading and what operations were being conducted (if applicable);
  - e. Status of all sound sources in use;
  - f. Description of avoidance measures/requirements that were in place at the time of the strike and what additional measures were taken, if any, to avoid strike;
  - g. Environmental conditions (*e.g.*, wind speed and direction, Beaufort sea state, cloud cover, visibility) immediately preceding the strike;
  - h. Estimated size and length of animal that was struck;
  - i. Description of the behavior of the marine mammal immediately preceding and following the strike;
  - j. If available, description of the presence and behavior of any other marine mammals immediately preceding the strike;
  - k. Estimated fate of the animal (*e.g.*, dead, injured but alive, injured and moving, blood or tissue observed in the water, status unknown, disappeared); and
  - l. To the extent practicable, photographs or video footage of the animal(s).

### Sound Monitoring Reporting

As described previously, Dominion Energy would be required to provide the initial results of SFV (including measurements) to NMFS in interim reports after each monopile installation for the first three piles (and any subsequent piles) as soon as they are available, but no later than 48 hours after each installation. In addition to in situ measured ranges to the Level A harassment and Level B harassment isopleths, the acoustic monitoring report must include: hammer energies (pile driving),  $SPL_{peak}$ ,  $SPL_{rms}$  that contains 90% of the acoustic energy, single strike sound exposure level, integration time for  $SPL_{rms}$ , and 24-hour cumulative SEL extrapolated from measurements. The sound levels reported must be in median and linear average (*i.e.*, average in linear space), and in dB. All these levels must be reported in the form of median, mean, max, and minimum. The SEL and SPL power spectral density and one-third octave band levels (usually calculated as decade band levels) at the receiver locations should be reported. The acoustic monitoring report must also include: a description of the SFV PAM hardware and software, including software version used, calibration data, bandwidth capability and sensitivity of hydrophone(s), any filters used in hardware or software, any limitations with the equipment, a description of the hydrophones used, hydrophone and water depth, distance to the pile driven, sediment type at the recording location, and local environmental conditions (*e.g.*, wind speed). In addition, pre- and post-activity ambient sound levels (broadband and/or within frequencies of concern) should be reported. Finally, the report must include a description of the noise abatement system and operational parameters (*e.g.*, bubble flow rate, distance deployed from the pile, *etc.*), and any action taken to adjust the noise abatement system. Final results of SFV must be submitted as soon as possible, but no later than within 90 days following completion of impact pile driving of monopiles.