

SH153
Un5714

1989

Grese

**Relative Survival of Subyearling
Chinook Salmon**
**Which Have Passed Bonneville Dam Via the
Spillway or the Second Powerhouse Turbines
or Bypass System in 1989,**
with Comparisons to 1987 and 1988

Ledgerwood

by
Richard D. Ledgerwood, Earl M. Dawley,
Lyle G. Gilbreath, Paul J. Bentley,
Benjamin P. Sandford, and Michael H. Schiewe

July 1990

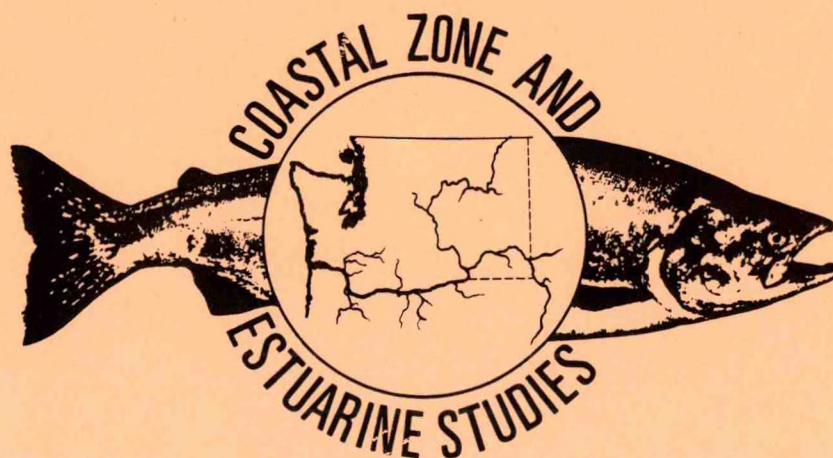

NWFS089

RELATIVE SURVIVAL OF SUBYEARLING CHINOOK SALMON WHICH HAVE PASSED
BONNEVILLE DAM VIA THE SPILLWAY OR THE SECOND POWERHOUSE TURBINES
OR BYPASS SYSTEM IN 1989, WITH COMPARISONS TO 1987 AND 1988

SH
153
Un 5714
1989

by
Richard D. Ledgerwood
Earl M. Dawley
Lyle G. Gilbreath
Paul J. Bentley
Benjamin P. Sandford
and
Michael H. Schiewe

Preliminary Report of Research
Funded by
U.S. Army Corps of Engineers
(Contract E85890024/E86890097)

and

Coastal Zone and Estuarine Studies Division
Northwest Fisheries Center
National Marine Fisheries Service
National Oceanic and Atmospheric Administration
2725 Montlake Boulevard East
Seattle, Washington 98112

July 1990

THIS REPORT MAY BE CITED AS:

Ledgerwood, R. D., E. M. Dawley, L. G. Gilbreath, P. J. Bentley,
B. P. Sandford, and M. H. Schiewe.

1990. Relative survival of subyearling chinook salmon which
have passed Bonneville Dam via the spillway or the Second
Powerhouse turbines or bypass system in 1989, with comparisons
to 1987 and 1988. Report to U.S. Army Corps of Engineers,
Contract E85890024/E86890097, 64 p. plus Appendixes.
(Available from Northwest Fisheries Center, 2725 Montlake
Blvd. E., Seattle, WA 98112-2097.)

CONTENTS

	Page
INTRODUCTION	1
METHODS	3
Experimental Design	3
Test Fish	6
Marking Procedures	7
Release Locations	8
Project Operating Parameters	18
Release Procedures	19
Recoveries at Jones Beach	21
Na ⁺ -K ⁺ ATPase Analysis	24
Diel Sampling	25
Stomach Fullness and Diet Composition	25
Statistical Analysis	26
RESULTS	27
Migration Behavior and Fish Condition	27
Diel Recovery Patterns	35
Stomach Fullness and Diet Composition	41
Juvenile Recovery Differences	41
Adult Recoveries	45
DISCUSSION	45
Multi-year Comparisons	45
Assumptions	52
Data Relevance	54

CONCLUSIONS	56
RECOMMENDATIONS	58
REFERENCES	60
APPENDIXES	65
Appendix A: Turbine Characteristics	65
Appendix B: Marking and Release Information: Tag Loss Estimates, Test Conditions, and Release Sequence	67
Appendix C: Recovery of Juveniles: Sampling Effort and River Conditions, Daily Recoveries (Raw Data and Data Standardized for Effort), Diel Patterns, and Diet Composition	73
Appendix D: Coded-Wire-Tag Processing	92
Appendix E: Statistical Analysis of Juvenile Catch Results	100
Appendix F: Turbine Operation Associated with Concurrent Fish Guidance Studies at the Second Powerhouse, Bonneville Dam Survival Study, 1987-89	115
Appendix G: Summary of Results of Juvenile Recoveries, Bonneville Dam Survival Study, 1987 and 1988	117
Appendix H: Flow patterns in Bonneville Dam Second Powerhouse Tailrace Based on Model Studies Conducted at the COE's Waterways Experiment Station	120
Appendix I: Ancillary Evaluations of the Bypass Systems at Bonneville Dam	123

INTRODUCTION

Research conducted since construction of the Columbia River's Bonneville Dam Second Powerhouse in 1983 has shown that subyearling chinook salmon (Oncorhynchus tshawytscha) migrating during the summer (mostly upriver bright stock, fall race), are not effectively guided into the bypass system from turbines equipped with submersible traveling screens (STS) (Gessel et al. 1990). The structural modifications resulting from these research efforts have increased guidance for yearling salmonids migrating during the spring from 19% to as high as 74%, whereas guidance for summer migrants has remained poor (25%). Earlier studies of fish guidance at the First Powerhouse, conducted during the spring, indicated that guidance of juvenile salmonids into that powerhouse's bypass system was greater than at the Second Powerhouse; 72% for subyearling chinook salmon, 76% for yearling chinook salmon, and 78% for steelhead (O. mykiss) (Krcma et al. 1982).

Previous studies by Holmes (1952) and Schoeneman et al. (1961) indicated that turbine passage mortality at Columbia River hydroelectric projects ranged from 10 to 15%. Schoeneman et al. (1961) also estimated that mortality associated with spillway passage was considerably less, approximately 2%.

To minimize turbine passage losses of summer migrants pending resolution of the guidance problem at the Second Powerhouse, the U.S. Army Corps of Engineers (COE) agreed, on an annual basis, to restrict operation of the Second Powerhouse. Nighttime operation

(when the preponderance of migrants pass the dam) was eliminated and daytime operation restricted to periods necessary to limit spill to 2,124 m³/sec (75,000 ft³/sec) or meet firm energy demands if energy was unavailable elsewhere in the power system. As a result, summer migrants usually passed Bonneville Dam via the turbines and bypass system of the First Powerhouse and, when flow conditions allowed, over the spillway.

The adequacy of the interim operating procedure for protecting downstream migrant salmonids at Bonneville Dam was not directly tested. There were several reasons to re-assess the passage survival at Bonneville Dam: 1) turbines at dams where previous survival studies were conducted had different physical features and operating characteristics than the Second Powerhouse (differences in elevation of the blade in relation to tailwater, dimension of blades, and hydraulic head) (Appendix Table A1); 2) the Kaplan turbines installed at the Second Powerhouse are more efficient (less cavitation) than those previously studied at Bonneville First Powerhouse, and passage mortality is thought to be inversely related to turbine efficiency (Smith 1961; Oligher and Donaldson 1965; Cramer 1965); and 3) survival studies sensitive enough to assess small differences in survival had not been conducted at Bonneville Dam since construction of spillway flow deflectors (installed to reduce dissolved gas supersaturation) or the Second Powerhouse and bypass system. Since initiation of this study, concurrent fish guidance research conducted at both powerhouses during the summers of 1988 and 1989 (Gessel et al. 1989, 1990) indicated that STSs at

the Second Powerhouse had higher guidance percentages (25%) than those at the First Powerhouse (8%). Hence, relative survival information specific to the passage routes tested here is critically needed for management of power production in relation to fish passage.

METHODS

Experimental Design

In 1987, the National Marine Fisheries Service (NMFS), in cooperation with the U.S. Army Corps of Engineers (COE), began a multi-year study to evaluate relative survival of subyearling fall chinook salmon which have passed the Bonneville Dam Second Powerhouse by way of the turbines, bypass, or spillway (Fig. 1). Estimates of short- and long-term survival of marked chinook salmon using various passage routes were calculated by comparing their recovery percentages to recovery percentages of groups released in the tailrace and in the river 2.5 km downstream. Short-term relative survival was based on recoveries of marked fish 157 km downstream from the dam at the head of the Columbia River estuary at Jones Beach, River Kilometer (Rkm) 75 (Fig. 2). Long-term relative survival will be based on returns of tagged and branded adult fish to ocean fisheries, Columbia River fisheries, and Columbia River hatcheries. Secondary objectives of the estuarine sampling were 1) to evaluate the success of the release strategies (by assessing recovery percentages), and 2) to identify possible differences among treatment groups which might complement observations of recovery

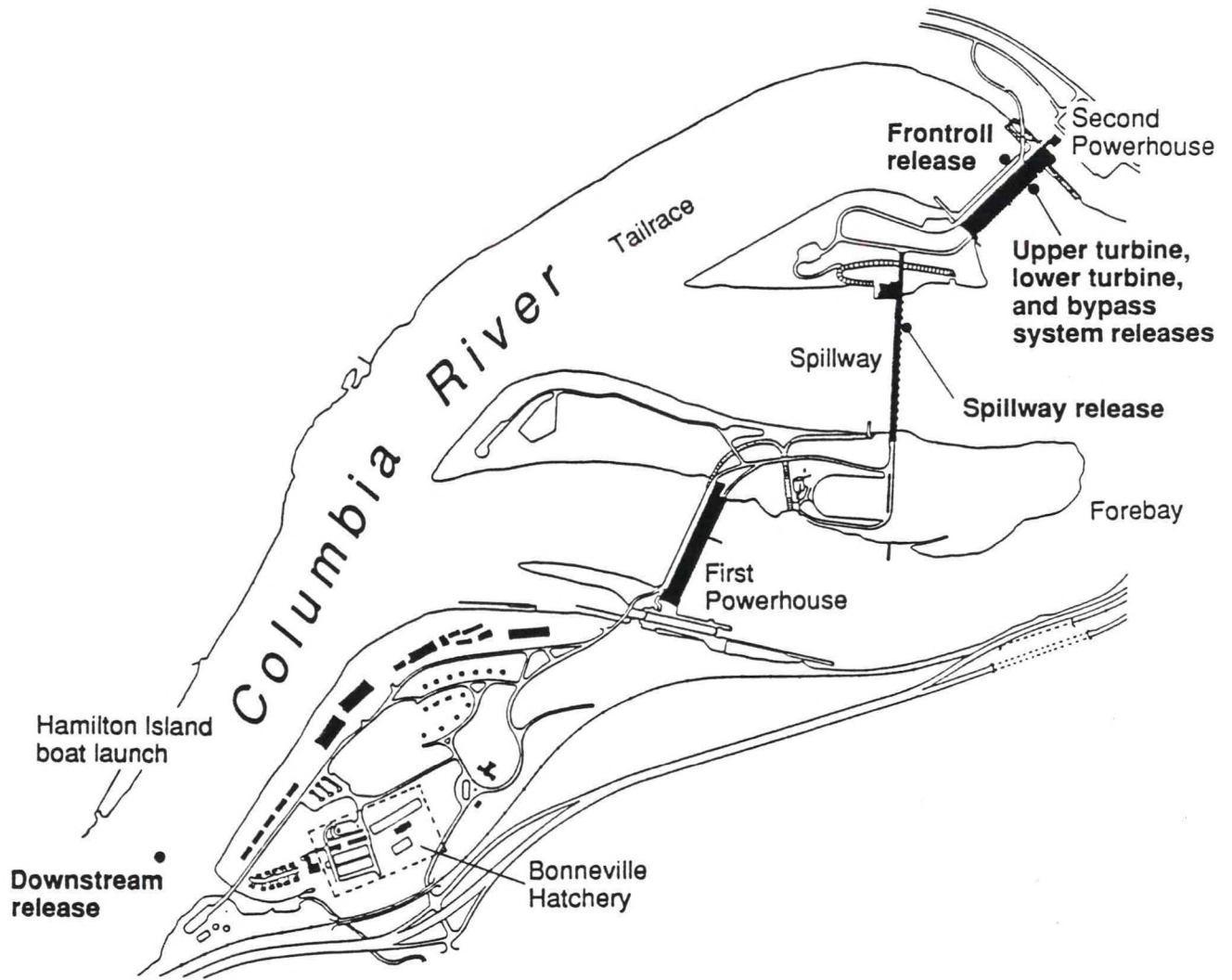

Figure 1.--Release locations for subyearling chinook salmon during the Bonneville Dam survival study, 1989.

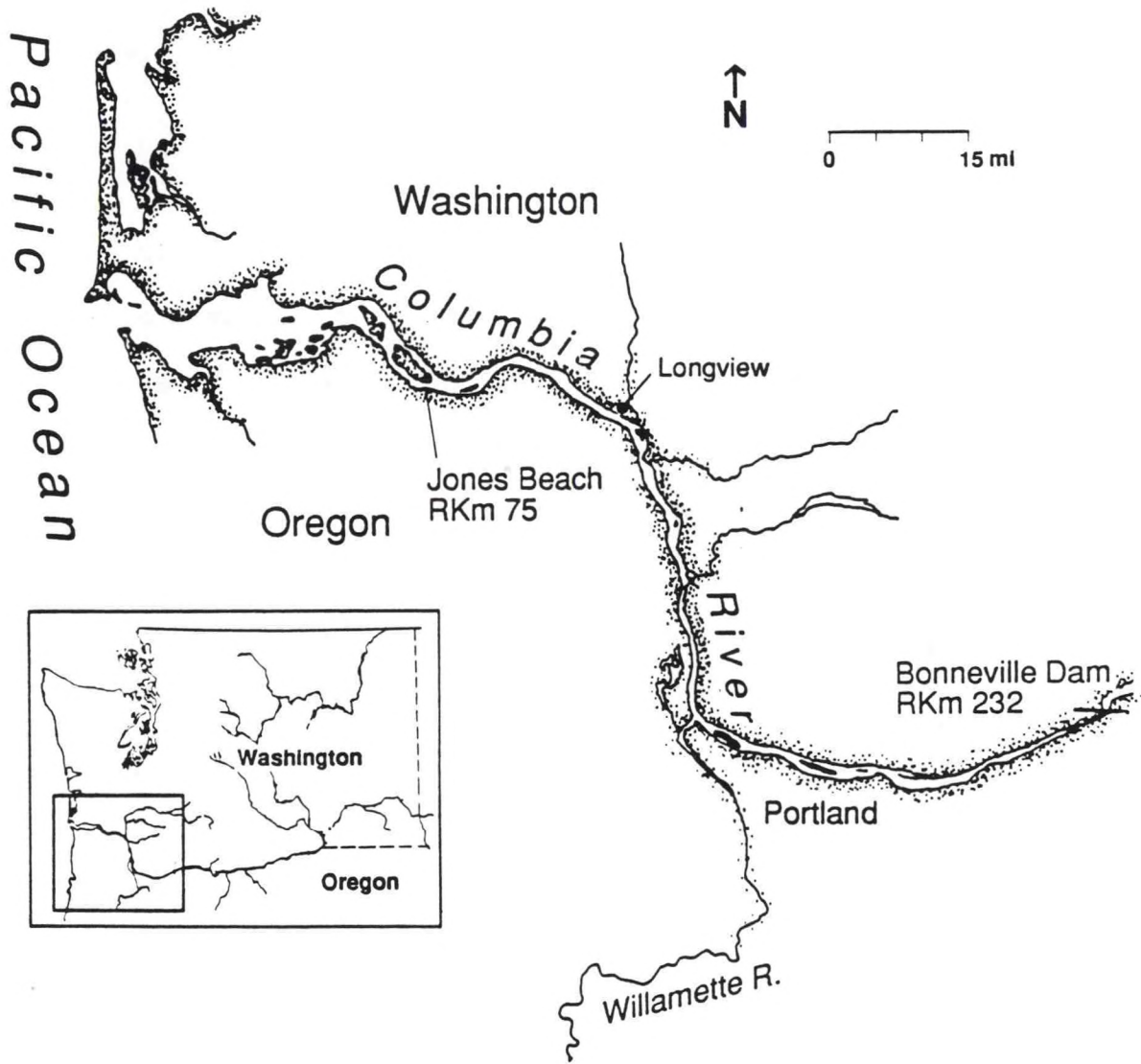

Figure 2.--The lower Columbia River showing locations of Bonneville Dam and the estuarine sampling site at Jones Beach, Oregon.

differences or reveal influences unrelated to passage effects (by assessing descaling, injuries, fish size, gill $\text{Na}^+\text{-K}^+$ ATPase, feeding habits, and migration behavior).

In 1989, as in the first 2 years of this study, test dates and dam operational criteria were chosen to represent conditions encountered by subyearling upriver bright fall chinook salmon migrating past Bonneville Dam. Test fish from Bonneville Hatchery were specifically chosen because of their similarity to summer migrants, availability, low probability of straying, and expected high percentage of adult returns (based on previous return data). Release locations for the bypass and turbine release groups were the same as those in 1987 and 1988; the downstream release was made at the 1988 mid-river location (Dawley et al. 1988, 1989). In 1989, for the first time, adequate river flows made it possible to test a spillway passage route.

Test Fish

In 1989, about 2.2 million additional subyearling upriver bright fall chinook salmon were reared specifically for this experiment at Bonneville Hatchery, operated by the Oregon Department of Fish and Wildlife (ODFW). Test fish were the progeny of fall chinook salmon (upriver bright stock) collected by ODFW personnel at Bonneville Hatchery. Eggs from early-spawning adults were obtained in November 1988 and fry were ponded in March 1989 to allow sufficient rearing time to produce juveniles weighing 6.1 to 10.2 g (45-75 fish/lb) with mean fork lengths of 83.4 to 99.4 mm at release; these fish were similar in size to those released in 1988.

Marking Procedures

Test fish were marked from 13 June to 21 July, Monday through Friday, using two marking crews; one crew worked from 0600 to 1400 h and the second from 1430 to 2230 h. About 60,000 fish were marked each day. The experimental design called for 12 release lots for each of 6 treatment groups, with each group consisting of about 30,000 fish. Each marked group had unique coded-wire tags (CWT) (Bergman et al. 1968) (Appendix Table B1). The CWTs were of the new replicate format employing replicate codes 1, 2, and 3 (unpublished, Northwest Marine Tech., Shaw Island, WA). Cold Brands (Mighell 1969) were used to visually identify fish from the different treatment groups. A total of 24 different brands were applied (Appendix Table B1).

Prior to marking, ODFW personnel at Bonneville Hatchery transported unmarked fish by truck from Batteries C and D to Battery A. A marking trailer was set up at the north end of Battery A, and fish were moved from Battery A to the holding tanks in the trailer using dip nets, apportioned to the marking stations, anesthetized with tricaine methane sulfonate (MS-222), and marked. Marked fish exited the trailer via 7.6-cm (3 in) diameter PVC pipes that led to subdivided holding ponds in Battery A.

Three measures were taken to ensure that marked groups did not differ in fish size, fish condition, rearing history, or mark quality: 1) the six marked groups needed for one release lot (i.e., a single night's release) were marked simultaneously; 2) the six marking stations were dedicated to unique treatment groups; and

3) differences in mark quality among groups were minimized by rotating fish markers between stations, such that each marking team contributed equivalent numbers of marked fish to each treatment group.

To maintain quality control in the tagging process, samples of about 100 fish from each marked group were collected about every 2 hours at the outfall pipe from the marking trailer and checked for CWTs. In addition, samples of about 10 fish from each marked group were diverted into a separate holding pond at 2-hour intervals throughout the marking day and held for a minimum of 30 days to determine tag loss and brand retention. Estimates of tag loss, based on extended holding of samples of each marked release group, ranged from 0 to 6.8% ($\bar{x} = 2.0\%$, $SE = 0.3$, $n = 8,010$; Appendix Table B1). Release data for juvenile and adult recovery comparisons include a correction using estimated tag loss.

Release Locations

The specific release locations and rationales for 1989 were as follows:

- 1) Upper Turbine--released in the intake of Turbine 17, just downstream from Gatewell B, and 1 m below the intake ceiling (elevation above sea level +6.5 m [21 ft]; Fig. 3). Ambient water velocity at the site is about 0.6 m/sec (2.0 ft/sec); derived from model studies conducted 7 August 1984 at the COE Waterways Experiment Station (WES), Vicksburg, Mississippi (personal communication, James Kuski, COE, Bonneville Dam,

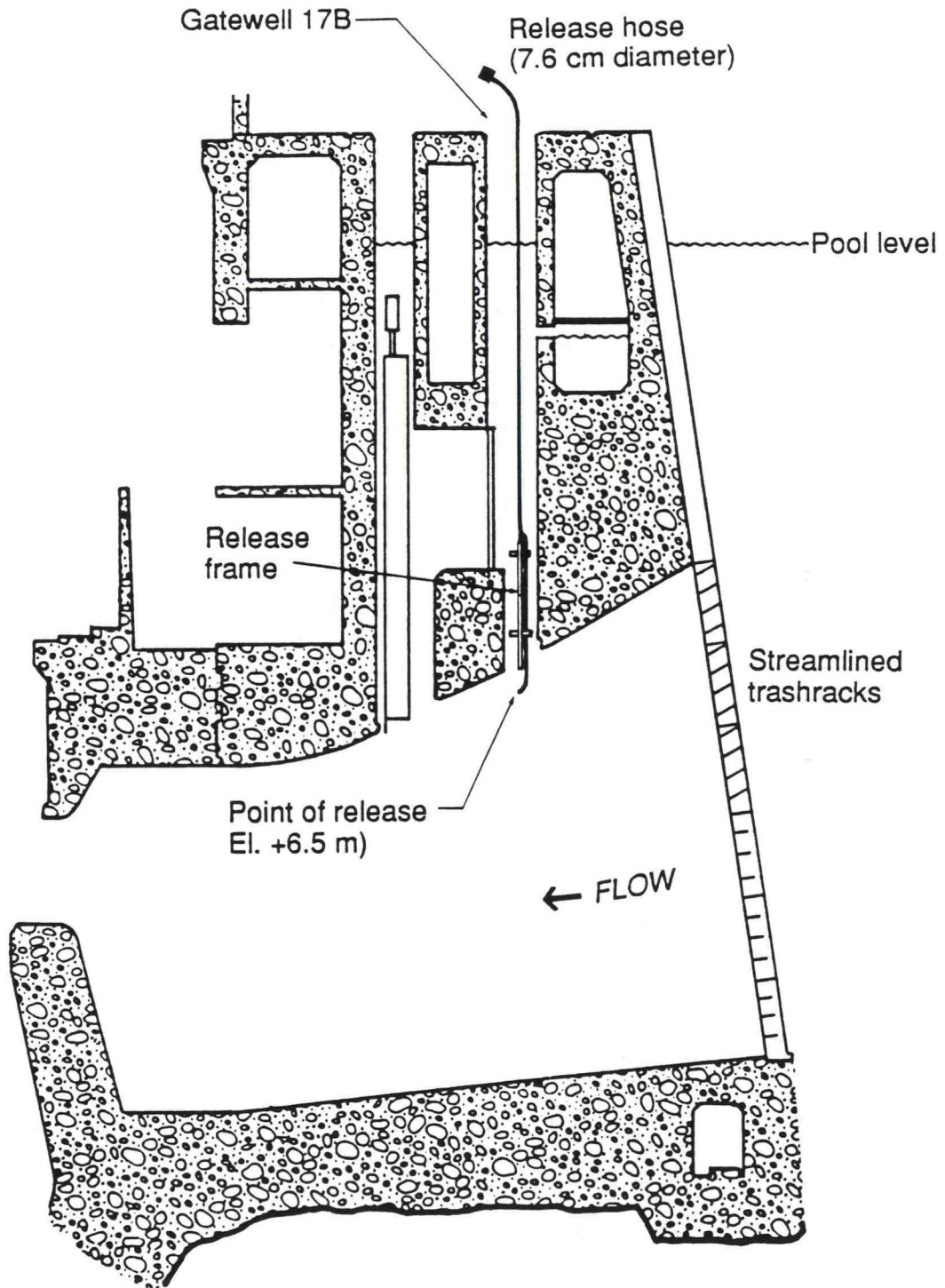

Figure 3.--Cross-section of Bonneville Dam Second Powerhouse depicting release location of upper turbine treatment group.

Cascade Locks, Oregon). This release was made without an STS in place to simulate conditions fish would encounter while passing into an unscreened turbine intake at a depth where, under normal operation (i.e., STS in place), they would have been intercepted by an STS and shunted into the gatewell and subsequently into the bypass system. Fish entering from this location would generally pass through the turbine near the blade hub (from model studies; personal communication, Brian Moentenich, COE, North Pacific Division, Portland, Oregon) and presumably suffer the least injury from high shear forces and blade strike (Long and Marquette 1964).

- 2) Lower Turbine--released in the intake of Turbine 17, just downstream from Gatewell A, and 1 m (3 ft) below the lowest interception depth of the STS (elevation +0.2 m [0.7 ft]; Fig. 4). Ambient water velocity at the site is about 1.9 m/sec (6.2 ft/sec) (Jensen 1987). This release was made with the STS in place to simulate conditions fish would encounter while passing into the middle of the intake, below the STS. Fish entering from this location pass through the turbine near the middle of the blade and presumably suffer greater injury than fish entering the upper turbine.
- 3) Bypass System--released in the bypass system collection-channel (elevation +20.0 m [66 ft]; Fig. 5) just downstream from the Turbine 17B orifice and upstream from the control weir, downwell, and 90° elbow entrance to the 287-m (942-ft) long by 0.9-m (3-ft)

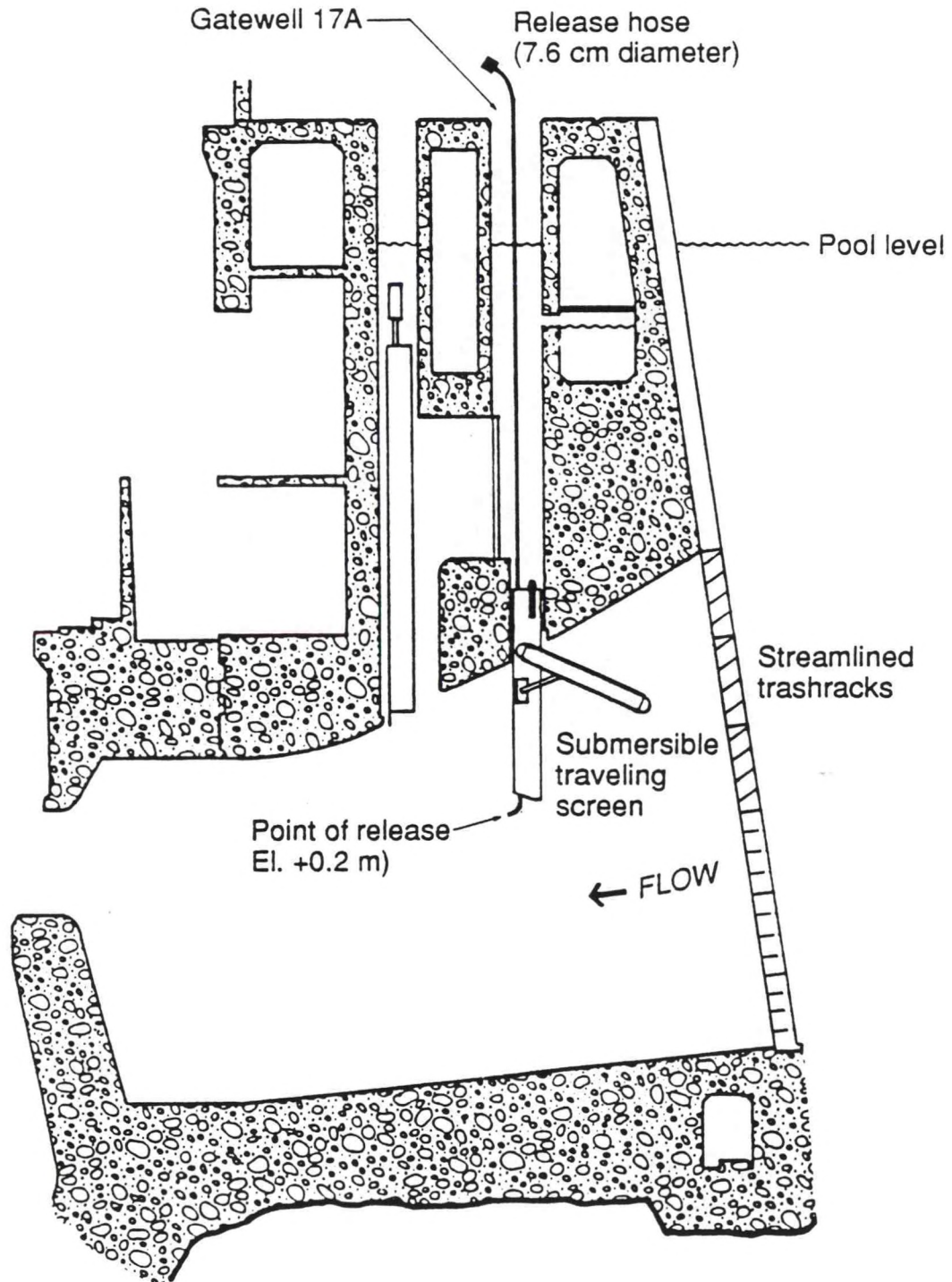

Figure 4.--Cross-section of Bonneville Dam Second Powerhouse depicting release location of lower turbine treatment group.

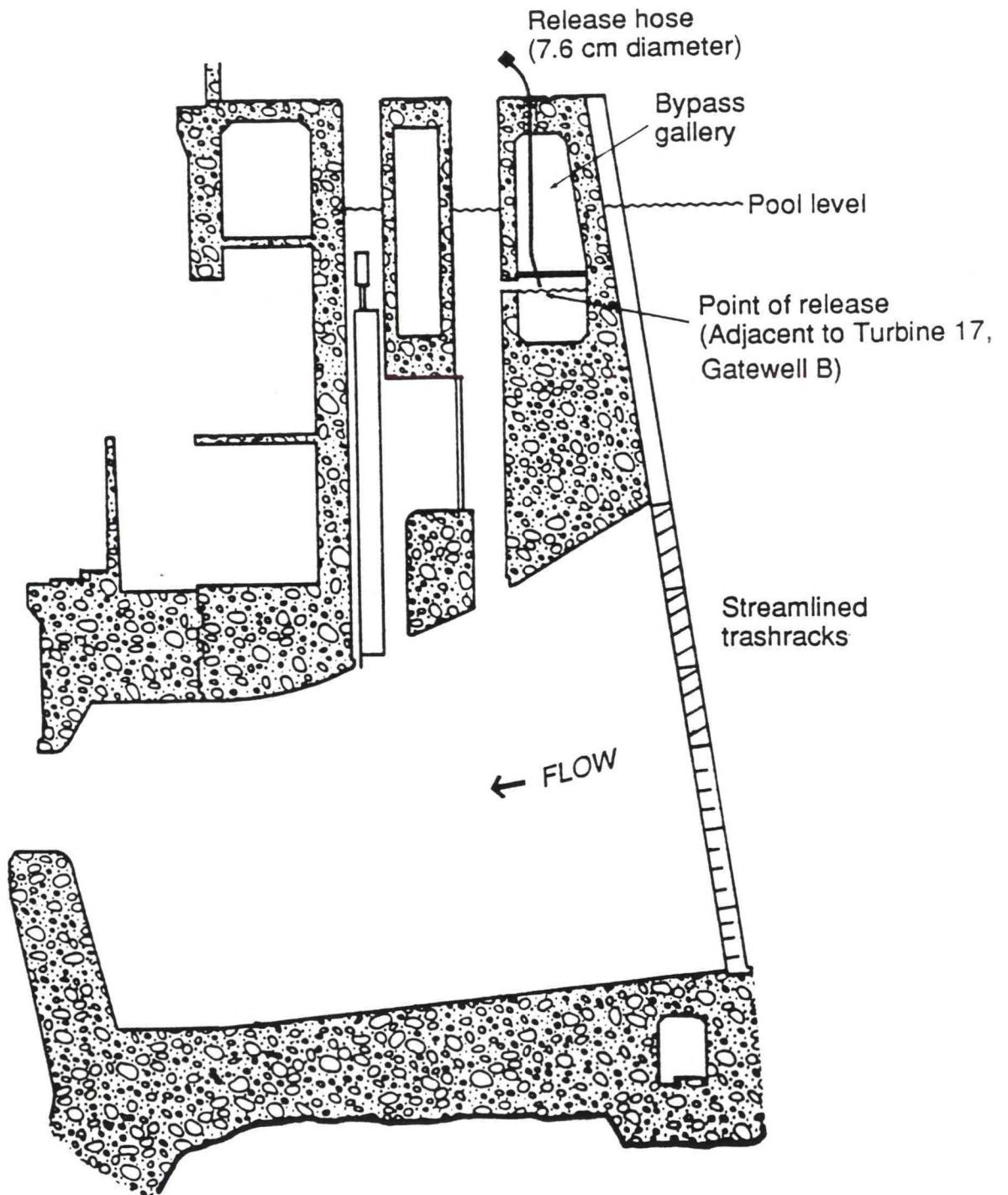

Figure 5.--Cross-section of Bonneville Dam Second Powerhouse depicting release location of bypass treatment group.

diameter conduit which discharges fish into the tailrace about 76 m (249 ft) downstream from the powerhouse (Fig. 6). Ambient water velocity of the channel at the release site is about 0.8 m/sec (2.6 ft/sec). The bypass system was regulated automatically to maintain flows at any combination of forebay and tailrace water elevations. This release was made to simulate conditions encountered by fish intercepted by an STS and shunted into the bypass channel.

- 4) Frontroll--released in the tailrace of the Second Powerhouse in the downstream portion of the Turbine 17 discharge boil, 30 m (98 ft) downstream from the powerhouse and 46 m (151 ft) upstream from the bypass system discharge (Fig. 6). Ambient surface water velocity at the release site is about 1.4 m/sec (4.6 ft/sec) downstream. Dye flushed from the frontroll release hose passed directly through the discharge boil of the bypass system. Thus, the frontroll release served as a reference group for assessing effects of test fish passing through the turbines and bypass system. Recoveries of fish released at this site, when compared to recoveries of the downstream release groups, isolate effects of passage through the tailrace from effects of passage through the turbine or bypass system.
- 5) Spillway--released through Spillbay 5 near the north end of the spillway with eight additional gates open and a total water flow of 1,500 m³/sec (53,000 ft³/sec; Fig. 7). Ambient water velocity at the release site is about 4.9 m/sec (16 ft/sec). This release was intended to simulate conditions that fish encounter when

Tailrace basin

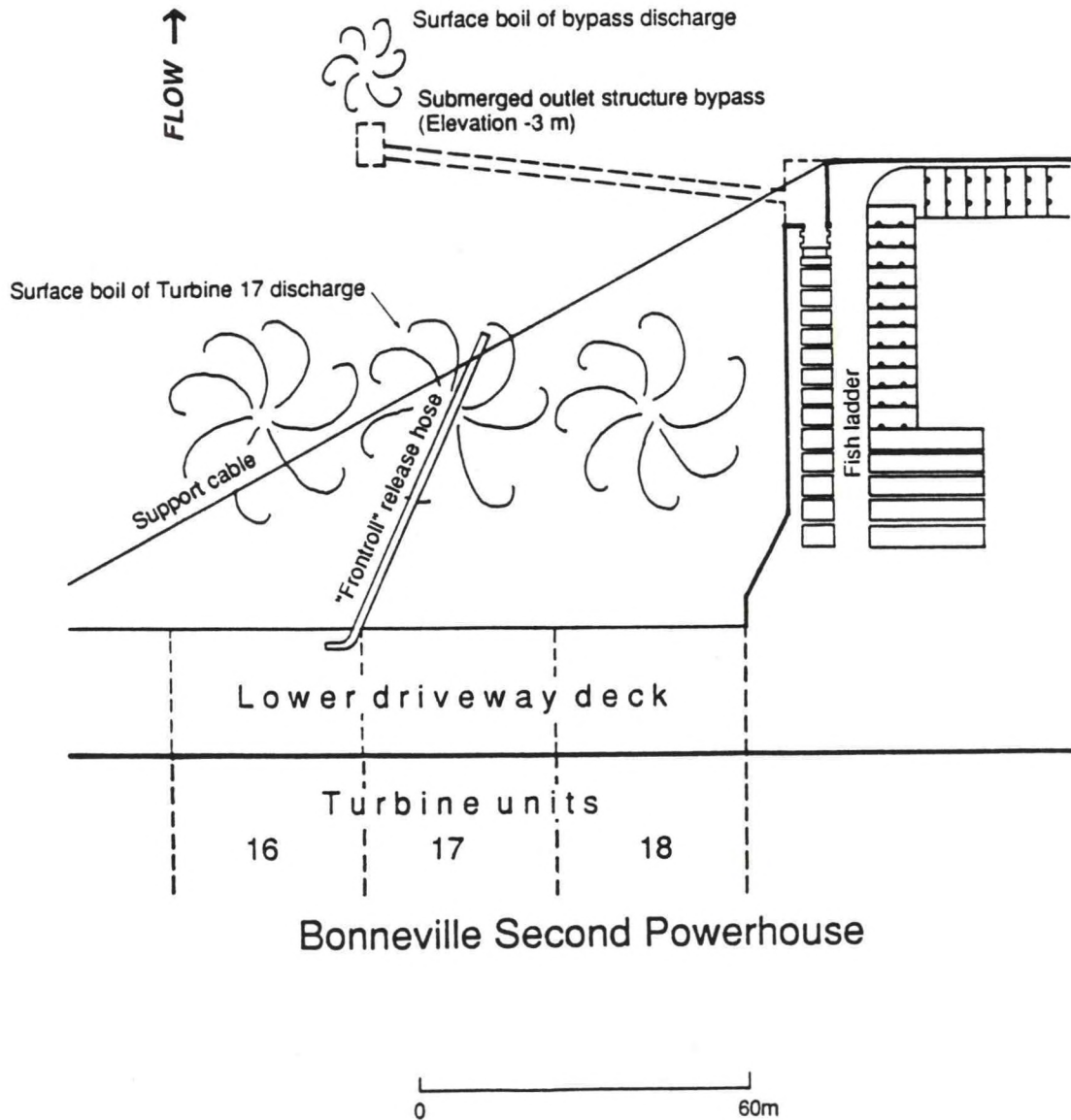
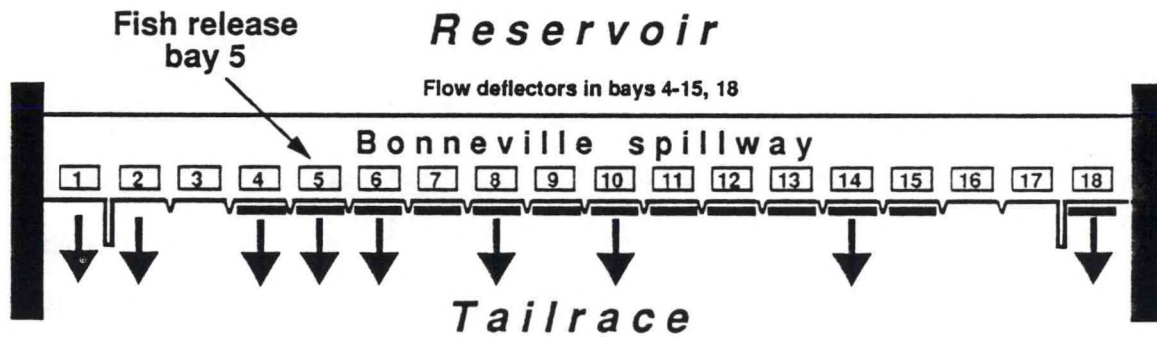

Figure 6.--Overhead view of Bonneville Dam Second Powerhouse depicting release location of the frontroll treatment group.



Spill bays open

1 2 4 5 6 8 10 14 18

Height (m)

0.1 1.5 0.9 0.9 0.9 0.9 0.9 0.9 0.9 0.1

Flow (m³/sec)

34 286 193 193 193 193 193 193 193 34

(1000ft³/sec)

1.2 10.1 6.8 6.8 6.8 6.8 6.8 6.8 6.8 1.2

Figure 7.--Spill gate opening pattern, water flow, and fish release location for the spillway treatment group.

passing through a spillbay with an attached flow deflector (13 of 18 bays have deflectors) and through the stilling basin in a tailrace current pattern which is similar to the established adult attraction flows (spill patterns developed by Junge and Carnegie, ODFW; reported in a letter dated 11 June 1975 to the Portland District, COE). The adult attraction flow gate opening pattern was altered to pass water from Spillbay 5 through the tailrace basin directly downstream. This pattern was formulated by examining various combinations of gate openings in the model of Bonneville Dam at WES. Spillbay 5 was open 0.9 m (3 ft; 2 latches) to ensure the safety of fish passage under the gate (Fig. 8). The tailrace surface elevation was maintained at 4.9 m (16 ft) to ensure that the Spillbay 5 discharge plume remained near the surface and did not dive into the energy dissipation baffles. Prior to testing, spillway flow at Bonneville Dam using the selected gate opening pattern developed at WES was examined. The discharge from Spillbay 5 appeared to skim along the surface over the top of the energy dissipation baffles and move directly downstream as observed in the model.

- 6) Downstream--released in mid-river, adjacent to the Hamilton Island boat launch ramp, about 2.5 km (1.6 mi) downstream from the dam (Fig. 1). This release was presumed to be downstream from effects of the dam and away from predators inhabiting the shoreline. Recoveries of fish released at this site, when compared to those of other treatment groups, isolate the effects of passage through the Second Powerhouse and tailrace, and the

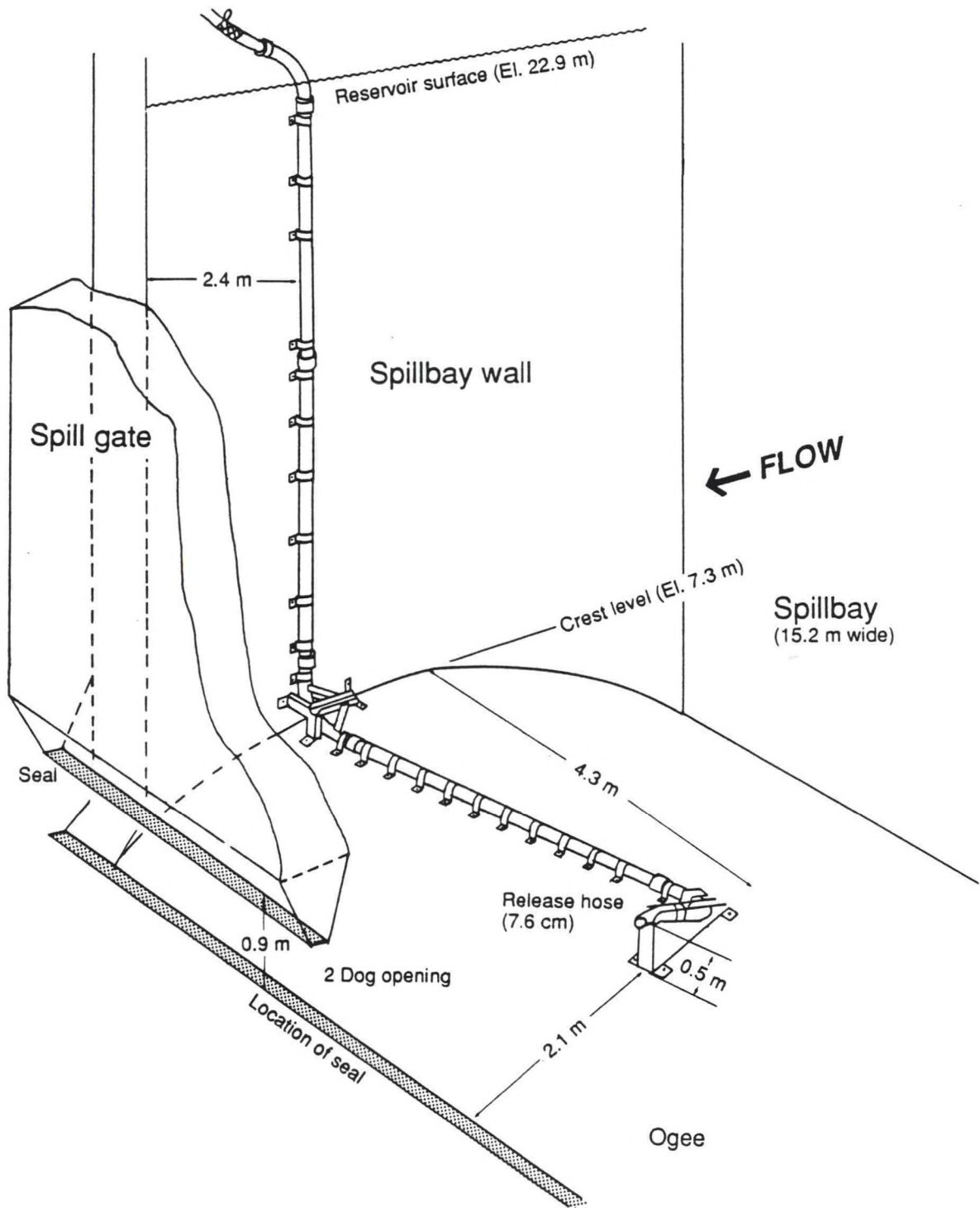

Figure 8.--Cut-away diagram of Spillbay 5, Bonneville Dam, depicting location of release hose relative to the spill gate.

effects of passage over the spillway and tailrace. The downstream release site was selected because it is downstream from both the First and Second Powerhouse tailraces and the river velocity is about 50% greater than that in the Second Powerhouse tailrace alone (about 1.4 m/sec [4.6 ft/sec] at test conditions with a river flow of 3,700 m³/sec [130 K·ft³/sec]). High flows in this area would likely disperse juveniles away from high concentrations of piscivores. Large populations of northern squawfish (Ptychocheilus oregonensis) are typically found in tailrace areas of dams and at hatchery release sites where salmon smolts and other fishes are concentrated (Thompson 1959; Thompson and Tufts 1967; Buchanan et al. 1981).

Project Operating Parameters

Turbines were operated at maximum efficiency for the available hydraulic head, power demands, and river conditions during the June-July test period. On release days, Second Powerhouse Turbines 11, 16, 17, and 18 were started at about 2400 h (2 to 3 hours before fish releases) and operated at 66-67 MW electrical load until about 0800 h. Second Powerhouse discharge during tests ranged from 1,600 to 1,900 m³/sec (57 to 68 k·ft³/sec), and operating head was 17.9 to 20.4 m (59 to 67 ft; Appendix Table B2).¹ Effective head for Turbine 17 is about 0.4 m (1.3 ft) less than the

¹ Flow data, operating conditions, and water temperatures at time of release for 1988 and 1987 are presented in Appendix Tables B3 and B4.

operating head due to occlusion by trashracks, debris, and water resistance past the intake structure (personal communication, Brian Moentenich, COE, North Pacific Division, Portland, Oregon). Under these conditions, the sigma varied from 0.76 to 0.96 and the calculated efficiency of the turbine remained nearly constant at 92.5% (from model studies data; Allis-Chalmers 1978).

Spillbays 1 and 18 were open continuously for adult salmon attraction; bays 2, 4, 6, 8, 10, and 14 were opened at 2400 h to increase tailwater elevation and begin stabilizing the tailrace flow pattern. To protect the release hose apparatus, Spillbay 5 was not opened until 0200 h. At about 0300 h Spillbay 5 was closed (30 min after fish release). Other spillbays were closed at 0800 h.

Release Procedures

On 12 days during the period from 22 June to 22 July, releases of about 30,000 marked fish were made at the six release sites during early morning darkness. The release schedule was advanced 1 week from that originally proposed due to projected low river-flows which threatened cancellation of the final spillway releases. The release days were selected to 1) coincide with the migration of juvenile upriver bright fall chinook salmon past Bonneville Dam, 2) provide sufficient time for marking yet not require more than 15 days holding prior to release, and 3) avoid high water-temperatures typical in late July and August. Three lots of marked fish were released in each of four time-series: 22-24 June, 6-8 July, 13-15 July, and 20-22 July.

The release sequence (hour of release) for the Second Powerhouse treatment groups was varied according to the schedule in Appendix Table B5. Upper turbine or lower turbine groups were paired alternately with bypass or frontroll groups, and two simultaneous releases were made at each of two times, about 0200 and 0230 h. These pairings were chosen so that the pattern of fish entering the tailrace would be similar at each release time. The turbine release groups entered the tailrace from the turbine discharge boil which dispersed fish over a large area (ca. 700 m² [7,800 ft²]); these were termed broadcast releases. The spillway release--a broadcast release into the spillway tailrace--was made at 0230 h. The bypass and frontroll groups entered the tailrace directly from a pipe or hose; these were termed point-source releases. The truck containing the downstream group was driven to the Hamilton Island boat launch ramp and driven aboard a 20-m (66-ft) vessel (an LCM landing craft provided by the COE). At about 0300 h, the landing craft moved to mid-river and held position while the fish were released (point-source release).

All releases except at the downstream site were made from the transport trucks using 7.6-cm (3-in) diameter smoothbore plastic hoses to carry the fish to the release point. The cam and groove type release-hose fittings were chamfered. Vertical distances from transport trucks to the water surface were about 6, 6, and 9 m (20, 20, and 30 ft), respectively, for turbine, spillway, and bypass releases. The vertical drop through the frontroll release hose was 7.5 m, and test fish fell an additional 4 m (13 ft) from the

suspended hose end to the tailwater surface. The downstream release was made through a 15-cm diameter smoothbore plastic hose with a 1-m vertical drop from which fish fell 1.5 m to the water surface. Hose discharge velocities were calculated to be 4.9, 3.7, 7.0, 4.0, 6.7, and 4.9 m/sec (16, 12, 23, 13, 22, and 16 ft/sec), respectively, for upper turbine, lower turbine, bypass, frontroll, spillway, and downstream releases. Velocity differences between water exiting the release hoses and the surrounding water were calculated to be less than 6.3 m/sec (21 ft/sec). The lowest differential velocity shown to cause mortality of juvenile salmonids in laboratory tests was 15 m/sec (50 ft/sec; Groves 1972).

Recoveries at Jones Beach

Assessment of short-term relative survival among release groups was made from comparisons of marked fish recovered near the upper boundary of the Columbia River estuary at Jones Beach (Fig. 9). Detailed description of the sampling site and the fishing gear may be found in Dawley et al. (1985, 1988, 1989).

Sampling was conducted by 2 to 4 crews, 7 days per week, 8 to 16 hours per day, beginning at sunrise (Appendix Table C1). Both purse seines (mid-river) and beach seines (Oregon shore) were used about every 4th day to determine whether study fish were captured in greater numbers in mid-river or near shore (Fig. 9). On other days, the gear-type shown to catch the greatest number of study fish was used by all crews. Beach seining was limited to the Oregon shore. In 1987, most study fish (smaller than in 1988-89) migrated in

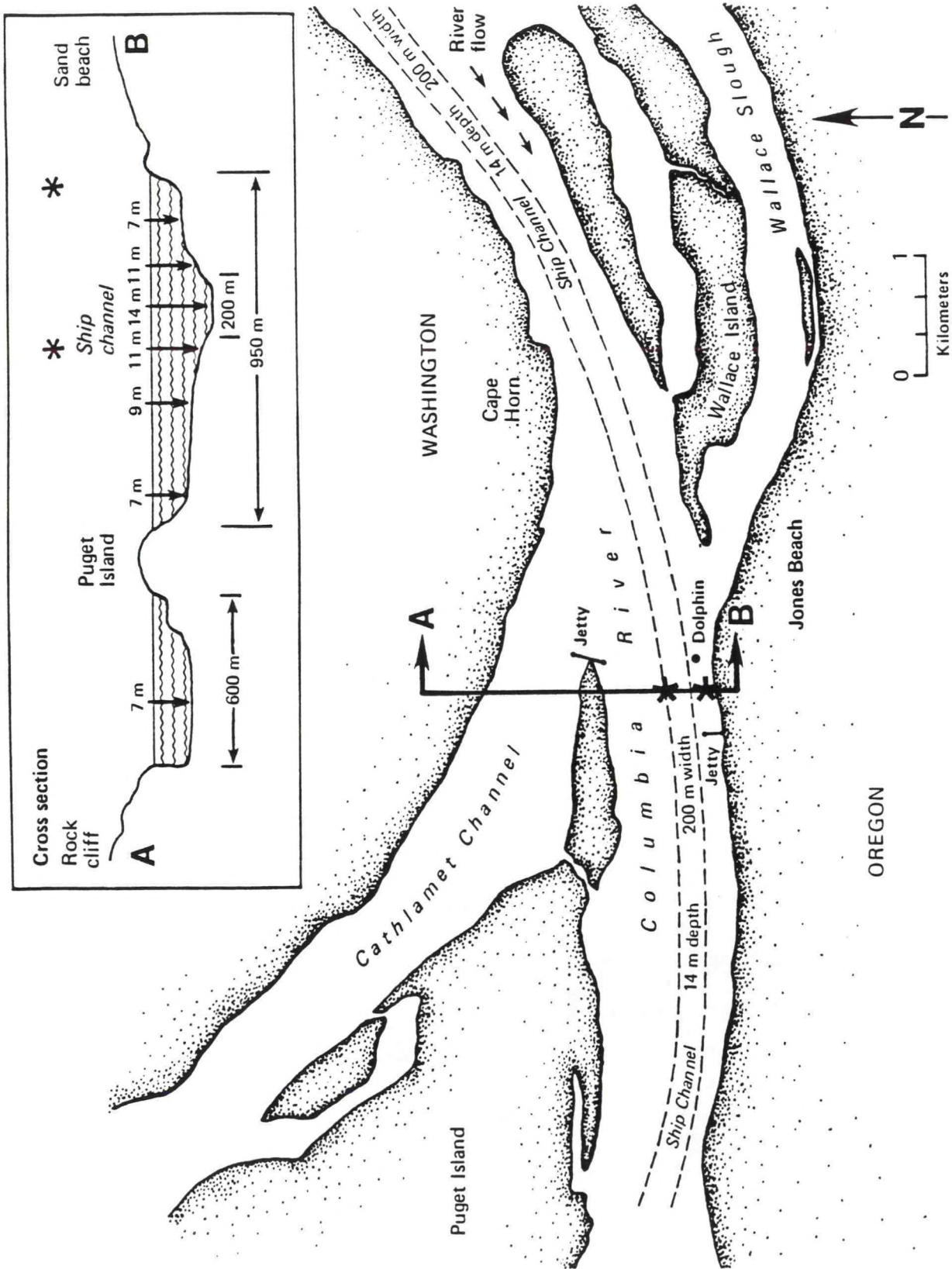

Figure 9.--Jones Beach, Columbia River, Oregon sampling sites. The beach- and purse-seining areas are denoted by asterisks.

shoreline areas, prompting additional beach seining on Puget Island and Washington shoreline sites.

All captured fish were processed aboard the purse seine vessels. The catch from each seine set was anesthetized using a solution of ethyl-*p*-aminobenzoate. Subyearling chinook salmon were examined for excised adipose fins, brands, descaling, and injury. Fork lengths of marked fish were recorded to the nearest mm. Brand information, fork length, and associated sampling data (i.e., vessel code, gear type, date, set number, time of examination) were immediately entered into a computer database and printed.

Brands were used to identify study fish for collecting CWTs, obtaining biological samples, comparing fish size among treatment groups, and adjusting the daily sampling effort to attain the desired minimum sample of 0.5% of release without overly impacting non-study fish. All branded fish (including those with an illegible brand) were sacrificed to obtain CWTs which identified treatment group and day of release. Adipose clipped fish with no visible brand were released (3,310 total).

The heads of branded fish containing CWTs were removed and placed in jars onboard the vessels; heads from beach seined fish were kept separate from those of purse seined fish. At the end of the day, a 40% solution of potassium hydroxide was added to the jars to dissolve the head tissue. A magnetic stirring rod was then placed in the jar and agitated on an electric stirrer to extract the CWTs from the slurry. The stirring rod, with attached CWTs, was then placed in a sonic agitator bath of vinegar for cleaning. All

CWTs were decoded and later verified using a 45X dissecting microscope. Additional details of tag processing are presented in Appendix D.

Purse seine catch data from 26 June through 3 August were standardized to represent an 18 set-per-day effort. Few fish were captured after 3 August, and effort was reduced during the final week of sampling; data from this period were not included in the standardized data set. Dates of median fish recovery for each marked group were determined using the standardized data. Movement rates for each CWT group were calculated as the distance from the downstream release site (RKm 232) to Jones Beach (RKm 75) divided by the travel time (in days) from release date to the date of median recovery.

Na⁺-K⁺ ATPase Analysis

Samples of about 20 fish were periodically sacrificed at the hatchery and at Jones Beach to measure gill Na⁺-K⁺ ATPase activity (micromoles ATP-hydrolyzed per mg protein per hour). Gill Na⁺-K⁺ ATPase activity is considered a useful index for assessing the degree of smoltification of juvenile salmon in the hatchery and after migration to the estuary (Zaugg and McLain 1970). In the hatchery, samples were taken beginning 18 April and every 2 to 3 weeks thereafter through mid-June. At release, samples were collected on the middle day of each of the four release series. At Jones Beach, samples were taken on 1, 15, 20, and 28 July, targeting groups released during each of the four release series. All

analyses were performed by W. Zaugg and staff, NMFS, Cook, Washington.

Diel Sampling

Diel purse seine sampling was conducted during two periods: 20-21 July and 29-30 July. Dates for sampling were selected to correspond to the approximate dates of the peak catches for the second and third release series.

Stomach Fullness and Diet Composition

Selected CWT-fish, collected primarily during diel sampling, were examined to assess possible differences among treatments in stomach fullness. For this evaluation, stomachs were excised (esophagus to pyloric caeca); cleaned of external fat; and a fullness value, based on the proportion of the total stomach length containing food, was estimated. A scale of 1 to 7 was used to quantify the fullness as follows: 1 = empty, 2 = trace of food, 3 = one-quarter full, 4 = half full, 5 = three-quarters full, 6 = full, and 7 = distended full (Terry 1977). Stomachs appearing empty were opened for examination, and a value of 2 was assigned if traces of food were observed. Selected stomachs were preserved in 10% buffered formaldehyde solution for determination of content weight and composition. Holding time prior to fullness observations was about 35 minutes.

Diet composition was obtained from samples of preserved stomachs used for fullness evaluation. Stomachs were opened longitudinally, the contents scraped onto a screen, blotted from beneath, allowed to

air dry for about 1 minute, weighed to the nearest 50 μg , and washed from the screen into a watch glass with a 70% solution of ethyl alcohol for examination. All stomachs from the same purse seine set were pooled. Organisms were identified to the lowest practical taxa; insects were further separated by metamorphic stage. In samples containing large numbers of cladocerans ($>1,000$), total numbers were estimated using weight.

Statistical Analysis

Differences among recovery percentages for each tagged group at Jones Beach were evaluated by analysis of variance (ANOVA) using a randomized block design where each release day was considered a block (Sokal and Rohlf 1981). Transformations of percentages were not required. Differences among descaling percentages of branded groups were also evaluated using ANOVA. Fisher's protected least significance procedures were used to rank treatment means for significant F-tests (Petersen 1985). Chi-square goodness of fit was used to test the hypothesis that different marked groups released the same day had equal probability of capture through time (Zar 1974). Chi-square was also used to test the hypothesis that each treatment group had equal probability of capture during darkness. Paired t-tests were used to evaluate the hypothesis that time (h) of release did not affect recovery percentages.

RESULTS

In 1989, a total of 2,166,715 fish were marked with freeze brands and CWTs, and by excision of the adipose fin (Table 1). A total of 18,385 study fish were recovered in the estuary (ca. 0.8% of those released); most were mid-river migrants captured with purse seines (Appendix Table C2). Handling mortality of recovered fish was less than 0.5%.

Migration Behavior and Fish Condition

Statistical analysis of migrational timing differences among treatment groups released on the same day showed no significant difference for 11 of 12 release lots ($\alpha = 0.05$), and no difference when the results of the individual tests were pooled ($P = 0.2257$; Appendix E). Temporal catch distribution of treatment groups released each day are presented for visual comparison in Figures 10 and 11 and Appendix Figures C1 and C2.

Movement rates of study fish from the release site at Bonneville Dam to Jones Beach ranged from 15.7 to 26.2 km/day (9.8 to 16.3 mi/day; Table 2); these rates were similar to those observed in 1988. Movement rates of the first four release-lots decreased as flow decreased (Appendix Fig. C3); however, later groups showed steadily increasing migration rates--probably a function of increased size at release. Comparison of fork length distributions of study fish at release to those at Jones Beach suggest that all groups grew during migration (Fig. 12). In contrast to the apparent

Table 1.--Summary of releases of marked subyearling chinook salmon, Bonneville Dam survival study, 1989.

Marking dates	Release date	Brand ^a	Number released			Wire tag code (AG D1 D2) ^c
			Total ^b	Untagged ^c	Tagged ^d	
Upper turbine releases						
07-09 June	22 June	RD>H1	30,086	968	29,118	23 26 56
09-14 "	23 "	RD>H1	30,096	969	29,127	23 28 04
14-16 "	24 "	RD>H1	30,075	968	29,107	23 28 16
19-21 "	06 July	RD>H3	30,090	571	29,519	23 28 28
22-24 "	07 "	RD>H3	30,116	572	29,544	23 28 41
24-28 "	08 "	RD>H3	30,120	572	29,548	23 28 52
28-30 "	13 "	LD>H1	30,106	543	29,563	23 31 01
06-08 July	14 "	LD>H1	30,085	543	29,542	23 31 13
08-11 "	15 "	LD>H1	30,118	543	29,575	23 31 25
11-14 "	20 "	LD>H3	30,136	0	30,136	23 31 37
14-17 "	21 "	LD>H3	30,072	0	30,072	23 31 49
17-19 "	22 "	LD>H3	<u>30,120</u>	<u>0</u>	<u>30,120</u>	23 31 61
	Subtotals:		361,220	6,249	354,971	
Lower turbine releases						
07-09 June	22 June	RD>K1	30,075	599	29,476	23 26 59
09-14 "	23 "	RD>K1	30,071	599	29,472	23 28 07
14-16 "	24 "	RD>K1	30,048	598	29,450	23 28 19
19-21 "	06 July	RD>K3	30,067	358	29,709	23 28 31
22-24 "	07 "	RD>K3	30,056	358	29,698	23 28 42
24-28 "	08 "	RD>K3	30,104	359	29,745	23 28 55
28-30 "	13 "	LD>K1	30,082	476	29,606	23 31 02
06-08 July	14 "	LD>K1	30,096	477	29,619	23 31 14
08-11 "	15 "	LD>K1	30,113	477	29,636	23 31 26
11-14 "	20 "	LD>K3	30,108	203	29,905	23 31 38
14-17 "	21 "	LD>K3	30,092	203	29,889	23 31 50
17-19 "	22 "	LD>K3	<u>30,120</u>	<u>203</u>	<u>29,917</u>	23 31 62
	Subtotals:		361,032	4,910	356,122	

Table 1.--Continued.

Marking dates	Release date	Brand ^a	Number released			Wire tag code (AG D1 D2) ^e
			Total ^b	Untagged ^c	Tagged ^d	
Bypass releases						
07-09 June	22 June	RD>L1	30,086	985	29,101	23 26 61
09-14 "	23 "	RD>L1	30,100	986	29,114	23 28 08
14-16 "	24 "	RD>L1	30,059	984	29,075	23 28 21
19-21 "	06 July	RD>L3	30,115	360	29,755	23 28 32
22-24 "	07 "	RD>L3	30,107	360	29,747	23 28 44
24-28 "	08 "	RD>L3	30,102	360	29,742	23 28 56
28-30 "	13 "	LD>L1	30,092	483	29,609	23 31 04
06-08 July	14 "	LD>L1	30,108	484	29,624	23 31 16
08-11 "	15 "	LD>L1	30,138	484	29,654	23 31 28
11-14 "	20 "	LD>L3	30,133	644	29,489	23 31 41
14-17 "	21 "	LD>L3	30,108	644	29,464	23 31 52
17-19 "	22 "	LD>L3	<u>29,832</u>	<u>638</u>	<u>29,194</u>	23 32 01
Subtotals:			360,980	7,412	353,568	
Frontroll releases						
07-09 June	22 June	RD>U1	30,094	1,291	28,803	23 26 62
09-14 "	23 "	RD>U1	30,081	1,291	28,790	23 28 11
14-16 "	24 "	RD>U1	30,072	1,290	28,782	23 28 22
19-21 "	06 July	RD>U3	30,067	425	29,642	23 28 35
22-24 "	07 "	RD>U3	30,072	425	29,647	23 28 47
24-28 "	08 "	RD>U3	30,098	425	29,673	23 28 59
28-30 "	13 "	LD>U1	30,121	852	29,269	23 31 07
06-08 July	14 "	LD>U1	30,099	852	29,247	23 31 19
08-11 "	15 "	LD>U1	30,113	852	29,261	23 31 31
11-14 "	20 "	LD>U3	30,165	378	29,787	23 31 42
14-17 "	21 "	LD>U3	30,116	377	29,739	23 31 55
17-19 "	22 "	LD>U3	<u>30,121</u>	<u>377</u>	<u>29,744</u>	23 32 02
Subtotals:			361,219	8,835	352,384	

Table 1.--Continued.

Marking dates	Release date	Brand ^a	Number released			Wire tag code (AG D1 D2) ^e
			Total ^b	Untagged ^c	Tagged ^d	
Spillway releases						
07-09 June	22 June	RD>V1	29,996	2,034	27,962	23 28 01
09-14 "	23 "	RD>V1	30,083	2,040	28,043	23 28 13
14-16 "	24 "	RD>V1	30,061	2,039	28,022	23 28 25
19-21 "	06 July	RD>V3	30,089	945	29,144	23 28 37
22-24 "	07 "	RD>V3	30,089	945	29,144	23 28 49
24-28 "	08 "	RD>V3	30,079	945	29,134	23 28 61
28-30 "	13 "	LD>V1	30,089	269	29,820	23 31 08
06-08 July	14 "	LD>V1	30,113	269	29,844	23 31 21
08-11 "	15 "	LD>V1	30,122	269	29,853	23 31 32
11-14 "	20 "	LD>V3	30,116	558	29,558	23 31 44
14-17 "	21 "	LD>V3	30,092	558	29,534	23 31 56
17-19 "	22 "	LD>V3	30,267	561	29,706	23 32 04
		Subtotals:	361,196	11,432	349,764	
Downstream releases						
07-09 June	22 June	RD>X1	30,086	349	29,737	23 28 02
09-14 "	23 "	RD>X1	30,083	349	29,734	23 28 14
14-16 "	24 "	RD>X1	30,070	349	29,721	23 28 26
19-21 "	06 July	RD>X3	30,051	661	29,390	23 28 38
22-24 "	07 "	RD>X3	30,035	661	29,374	23 28 50
24-28 "	08 "	RD>X3	30,061	661	29,400	23 28 62
28-30 "	13 "	LD>X1	30,089	430	29,659	23 31 11
06-08 July	14 "	LD>X1	30,119	431	29,688	23 31 22
08-11 "	15 "	LD>X1	30,125	431	29,694	23 31 35
11-14 "	20 "	LD>X3	30,140	68	30,072	23 31 47
14-17 "	21 "	LD>X3	30,094	68	30,026	23 31 59
17-19 "	22 "	LD>X3	30,115	68	30,047	23 32 07
		Subtotals:	361,068	4,526	356,542	
Totals			2,166,715	43,364	2,123,351	

^a Brand position RD (right dorsal) or LD (left dorsal) followed by the letter brand symbol; the numbers 1 or 3 indicate brand rotation.

^b Total fish marked; branded, tagged, and adipose fin clipped.

^c Based upon a subsample of branded fish held post-release in the hatchery for a minimum of 30 days (see Appendix Table B1 for data).

^d Number marked minus tag loss estimate.

^e AG D1 D2 = coded-wire tag codes for Agency, Data 1, and Data 2; all tags were in replicate format, utilizing sequentially applied codes 1, 2, or 3.

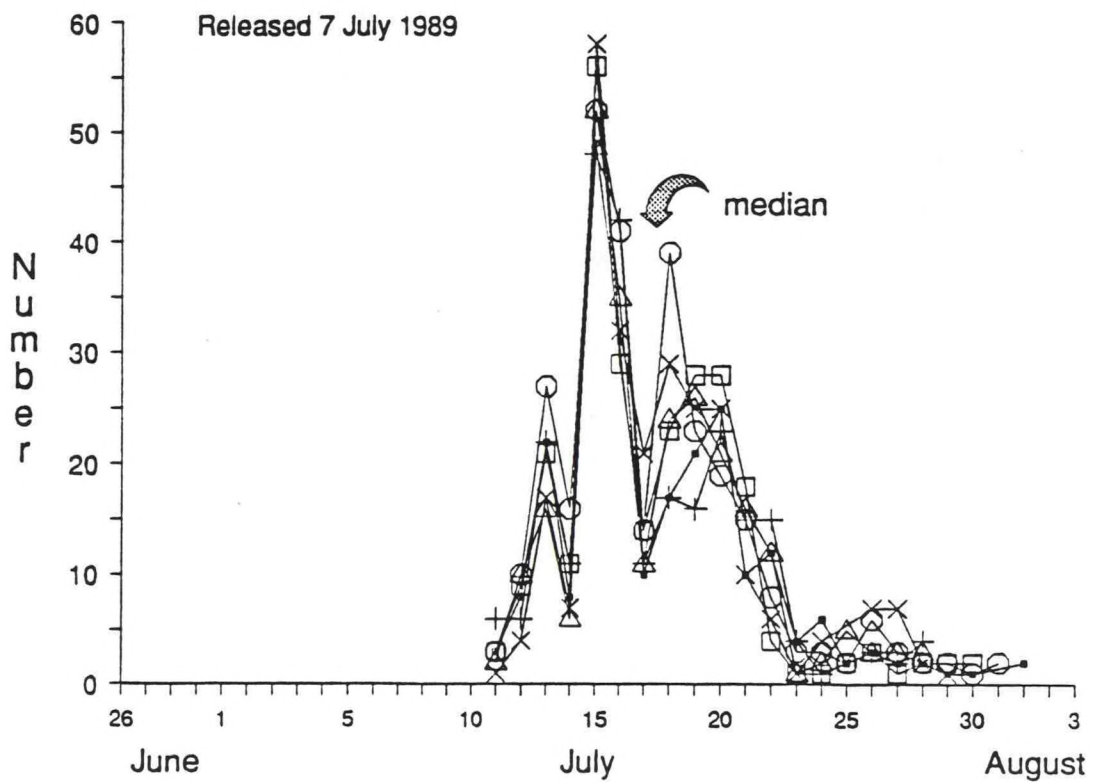
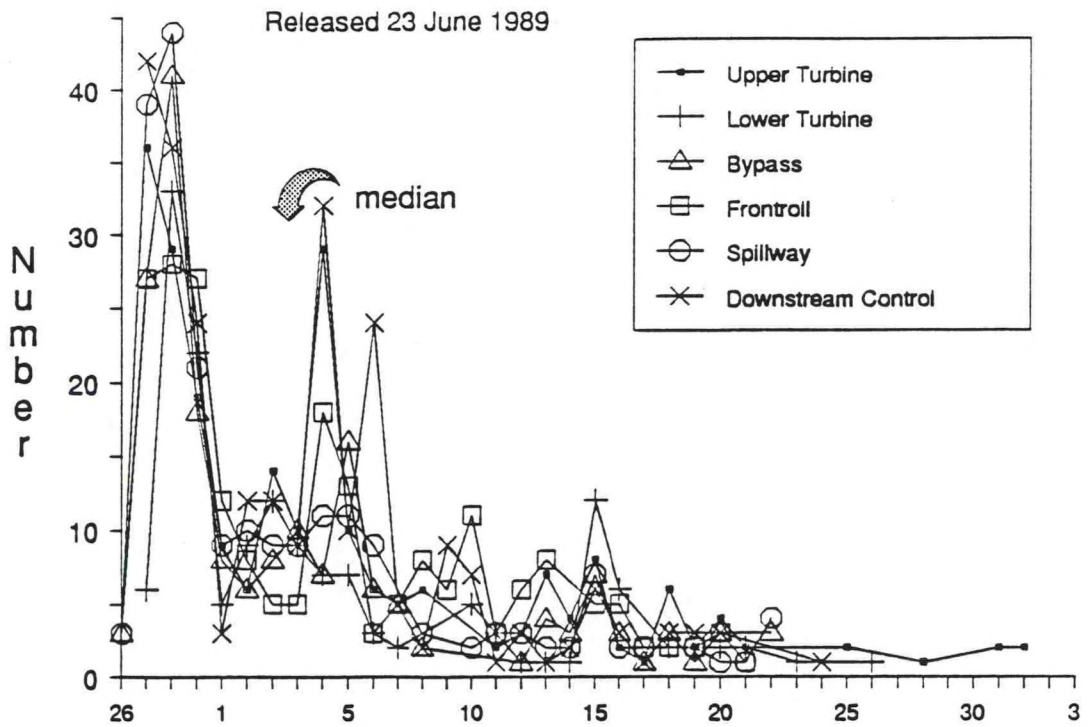

Figure 10.--Daily recoveries of test fish by treatment (standardized for effort) at Jones Beach, 1989. Data shown are from the groups released on the middle day of the first two release series.

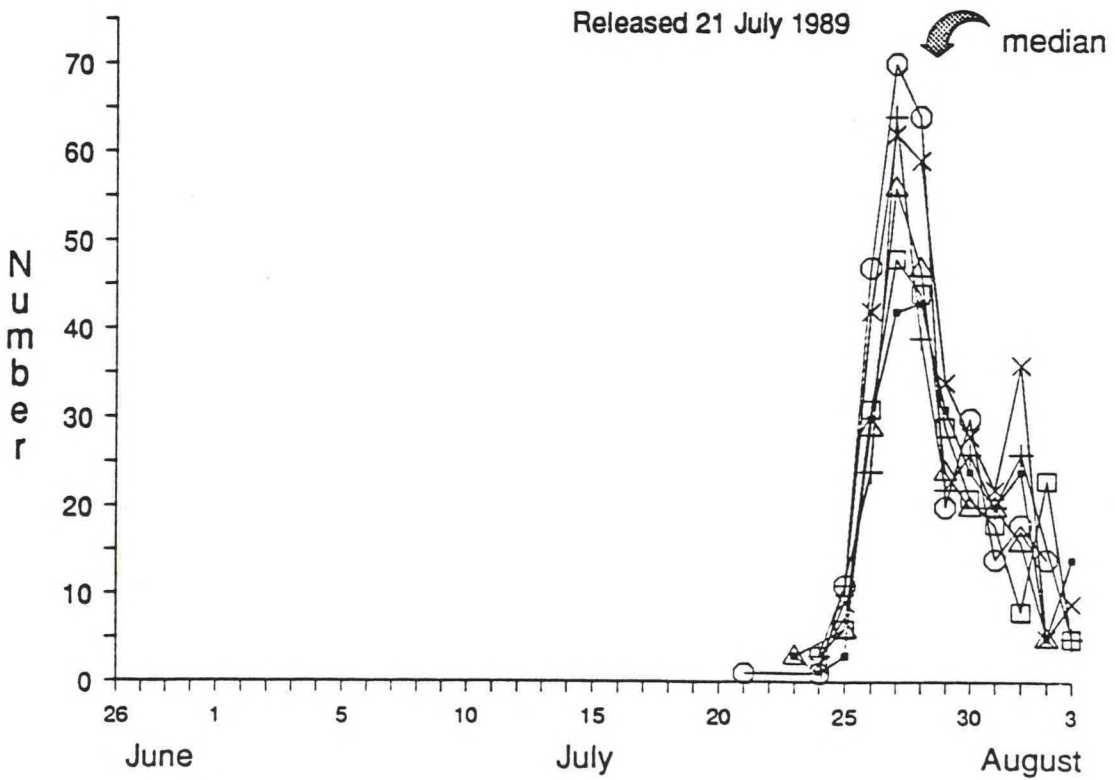
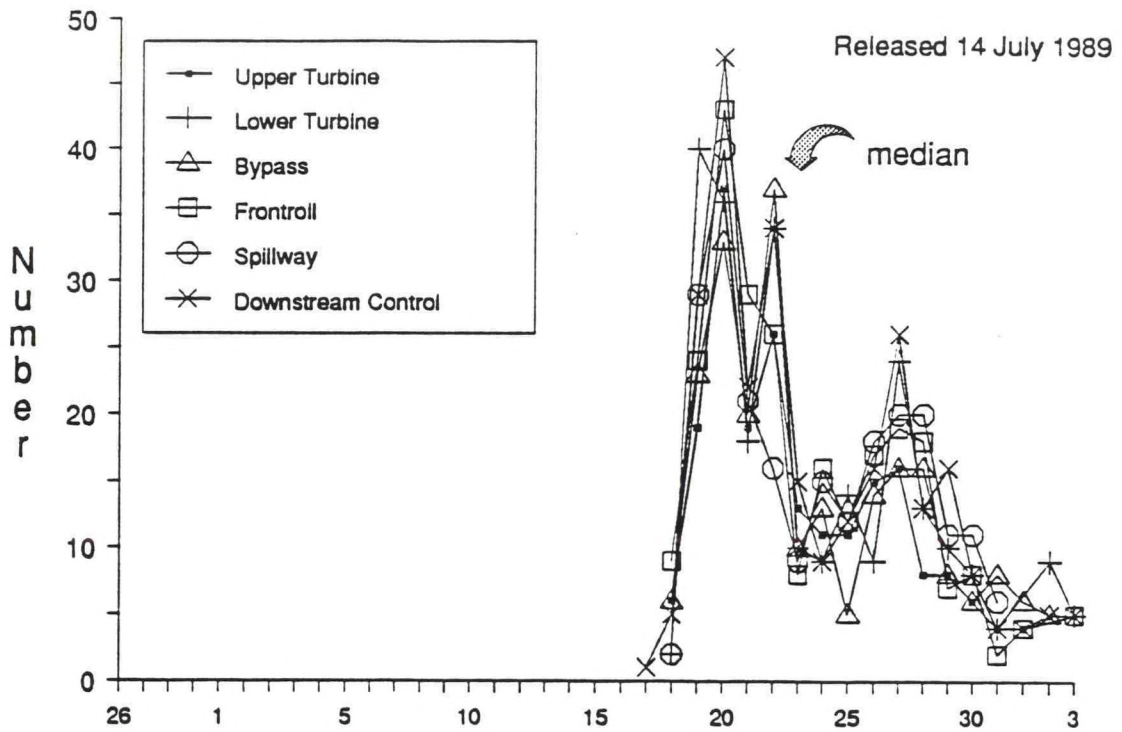

Figure 11.--Daily recoveries of test fish by treatment (standardized for effort) at Jones Beach, 1989. Data shown are from the groups released on the middle day of the last two release series.

Table 2.--Movement rates from Bonneville Dam to Jones Beach for marked groups of subyearling chinook salmon, Bonneville Dam survival study, 1989.

Release date ^b	Movement rate (km/day) ^a						Mean	Flow (K·ft ³ /sec) ^c
	Upper turbine	Lower turbine	Bypass system	Frontroll	Spillway	Downstream		
22 Jun	22.4	22.4	26.2	19.6	22.4	22.4	22.6	128.4
23 Jun	17.4	17.4	22.4	17.4	26.2	17.4	19.7	128.4
24 Jun	17.4	19.6	15.7	15.7	17.4	15.7	16.9	126.5
6 Jul	15.7	15.7	15.7	15.7	15.7	15.7	15.7	111.4
7 Jul	17.4	17.4	15.7	17.4	17.4	15.7	16.8	111.0
8 Jul	17.4	15.7	15.7	17.4	15.7	17.4	16.5	111.0
13 Jul	17.4	17.4	17.4	17.4	17.4	17.4	17.4	100.9
14 Jul	19.6	19.6	19.6	19.6	17.4	19.6	19.2	100.9
15 Jul	17.4	22.4	17.4	17.4	17.4	15.7	17.9	99.1
20 Jul	22.4	22.4	22.4	22.4	22.4	22.4	22.4	95.9
21 Jul	22.4	22.4	22.4	22.4	22.4	22.4	22.4	101.1
22 Jul	26.2	22.4	26.2	22.4	26.2	22.4	24.3	101.5

^a Purse seine recoveries standardized to an 18 set per day effort (Appendix Table C2). Movement rate = distance from the downstream release site (Rkm 232) to recovery site (Rkm 75) ÷ travel time in days from release to median fish recovery.

^b Fish released during early morning darkness.

^c Average flow through Bonneville Dam within 4 days of the date that the median fish was captured; by convention, English units were used for river flow volumes (K·ft³/sec = 1,000 ft³/sec = 28.3 m³/sec).

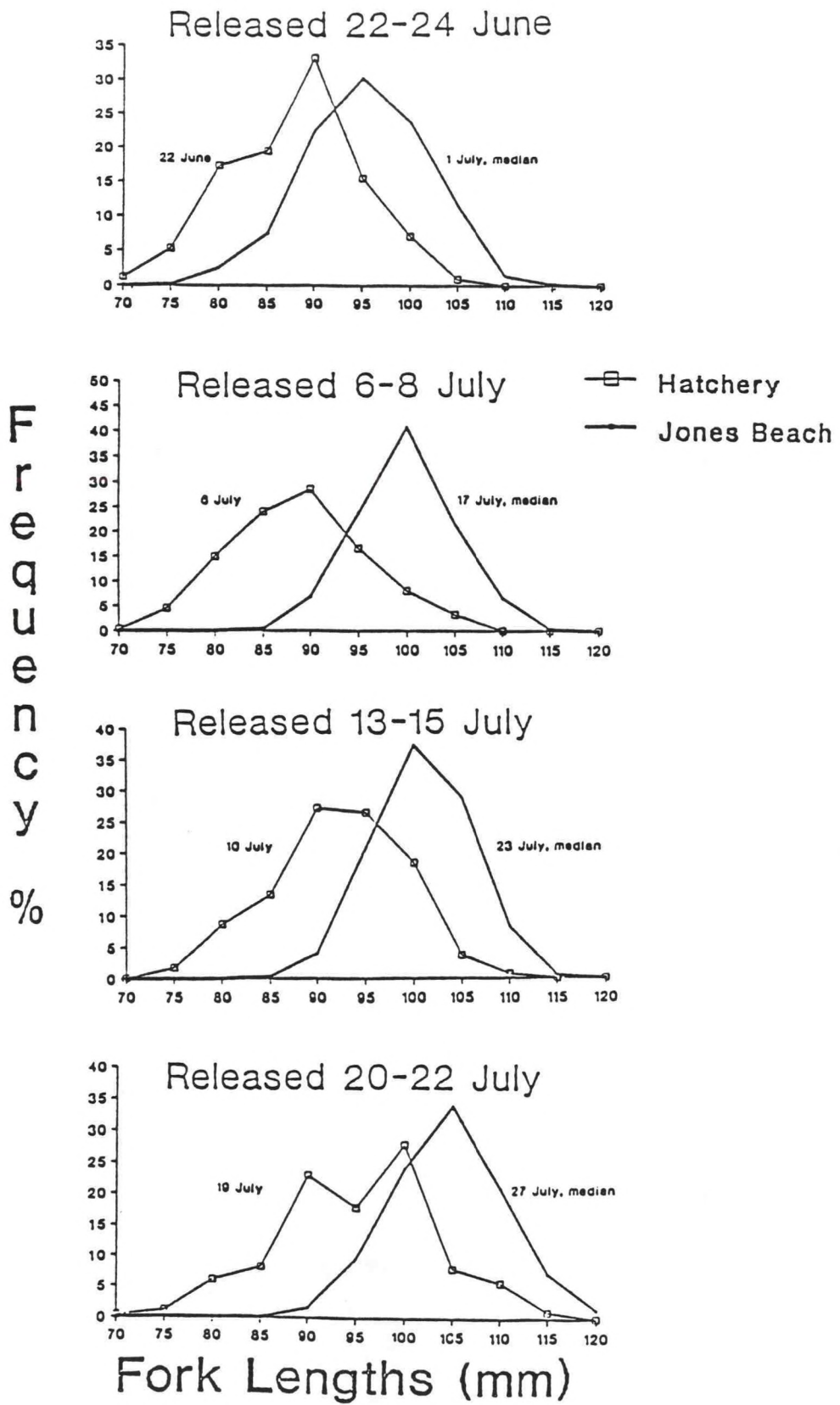

Figure 12.--Fork length distributions of fish at release and after recovery in the estuary, Bonneville Dam survival study, 1989.

loss of smaller-sized fish in 1988, there was no indication that smaller fish dropped out of the population during migration to Jones Beach in 1989. In addition, there were no indications of temporal differences relative to size of fish among treatment groups after recovery at Jones Beach (Figs. 13 and 14).

In the hatchery, $\text{Na}^+\text{-K}^+$ ATPase activity of study fish peaked on 12 June, about 7 weeks later than in 1988, with a mean $\text{Na}^+\text{-K}^+$ ATPase activity of 15.3 (SE = 0.84; Fig. 15). Following marking, holding, and transfer to the dam, $\text{Na}^+\text{-K}^+$ ATPase activities declined somewhat from the peak observed in the hatchery (\bar{x} = 14.2, SE = 1.68). After migration to Jones Beach, the $\text{Na}^+\text{-K}^+$ ATPase activity was higher (\bar{x} = 29.8, SE = 1.34); the average increase in activity was 15.6 for the paired samples from each of the four release series. The elevated activity following release and migration to the estuary was similar to elevations observed following release in previous years.

Descaled test fish recovered at Jones Beach ranged from 1.2 to 2.0% of the total recovered, and there were no significant differences among treatments (α = 0.05, Table 3; Appendix E).

Diel Recovery Patterns

During the two diel sampling periods, about 6% of the recovered marked fish were captured during darkness (in about 27% of the total sets; Appendix Table C3). There were no significant differences among treatments in daylight/darkness catch ratios (Chi square = 4.266, 5 df, P = 0.5118). Catches were highest at sunrise, fluctuated through daylight hours, and were lowest at night

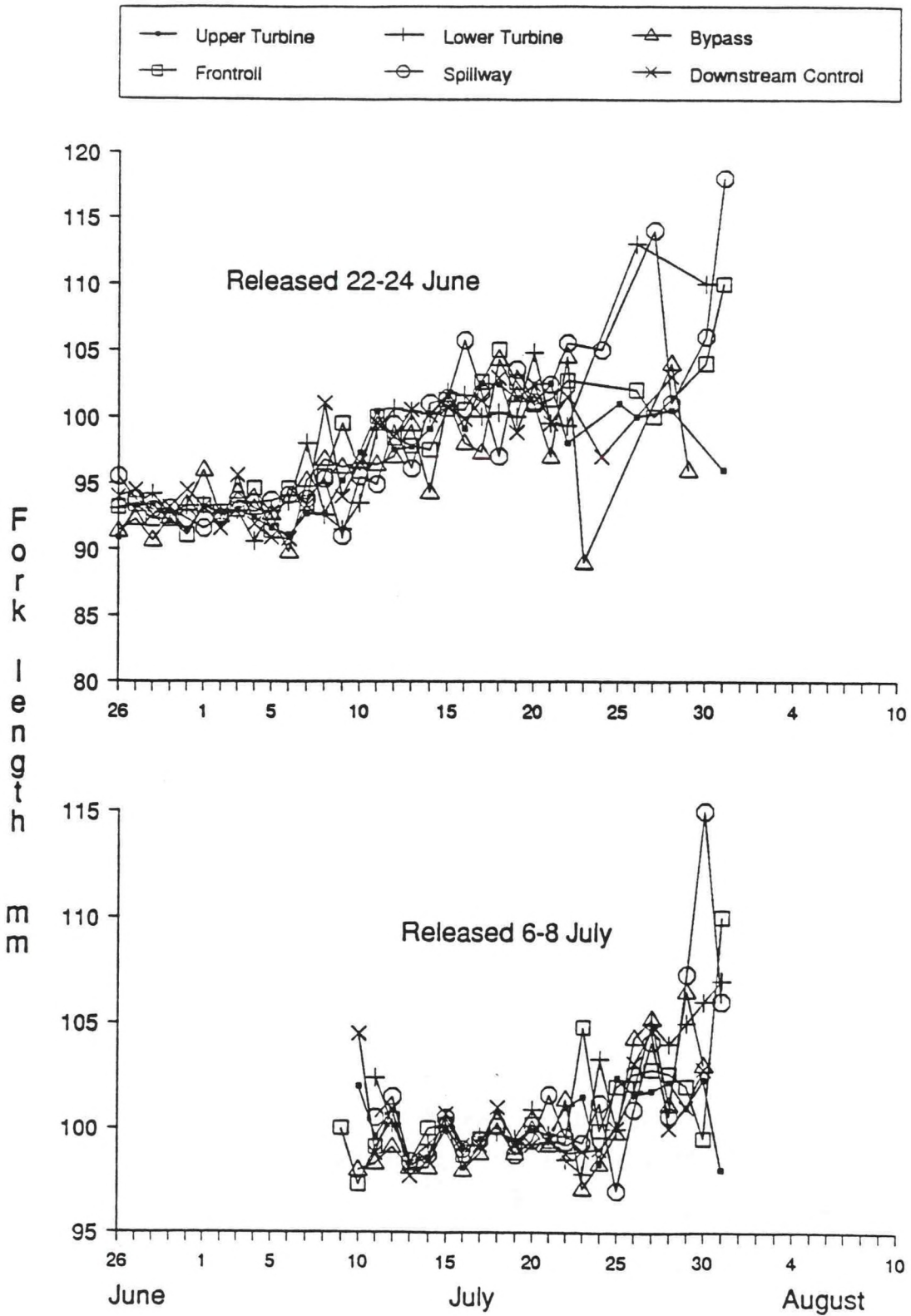

Figure 13.--Daily mean fork lengths of subyearling chinook salmon recovered at Jones Beach comparing treatments from the first two release series, 1989.

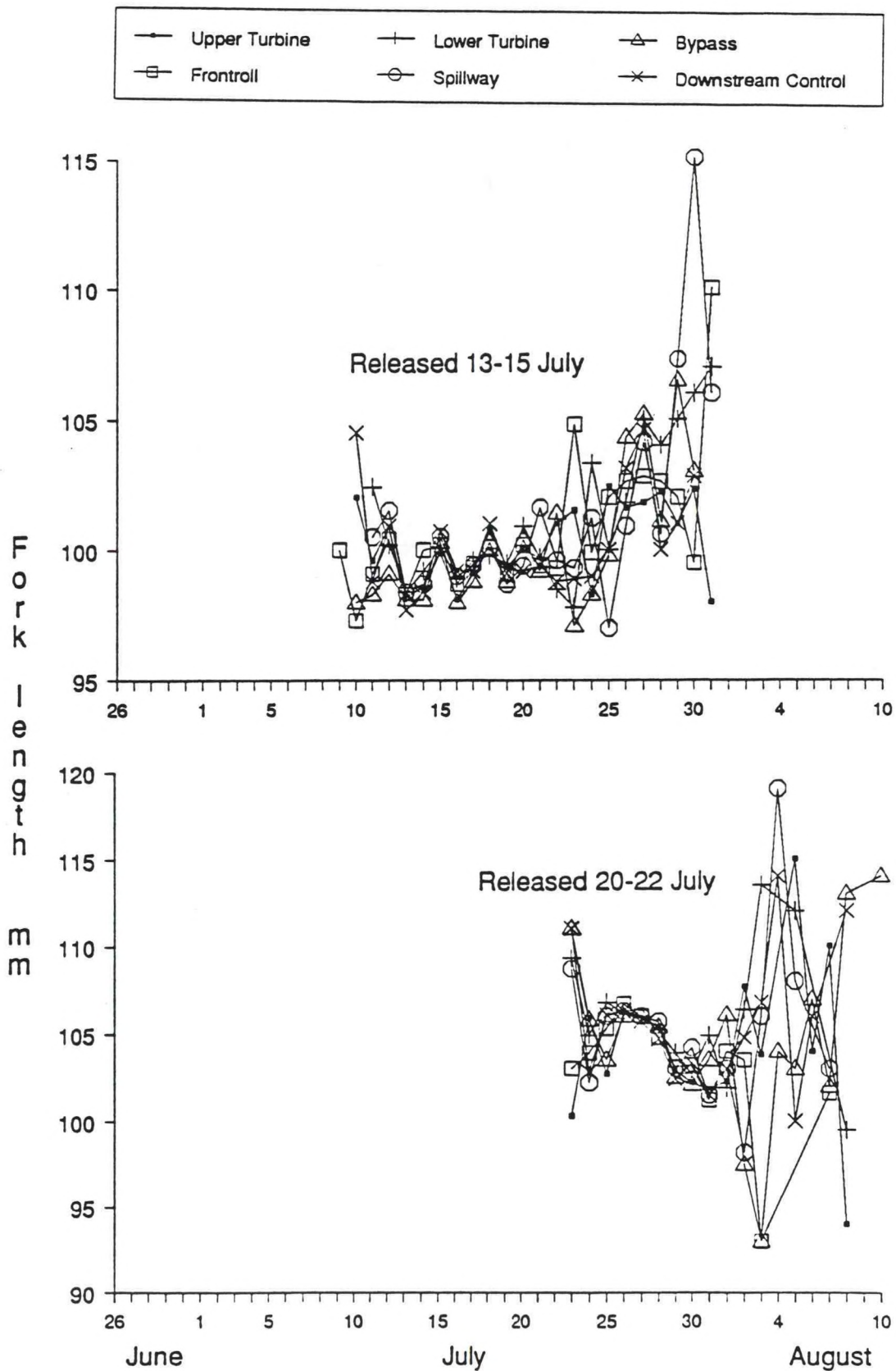

Figure 14.--Daily mean fork lengths of subyearling chinook salmon recovered at Jones Beach comparing treatments from the last two release series, 1989.

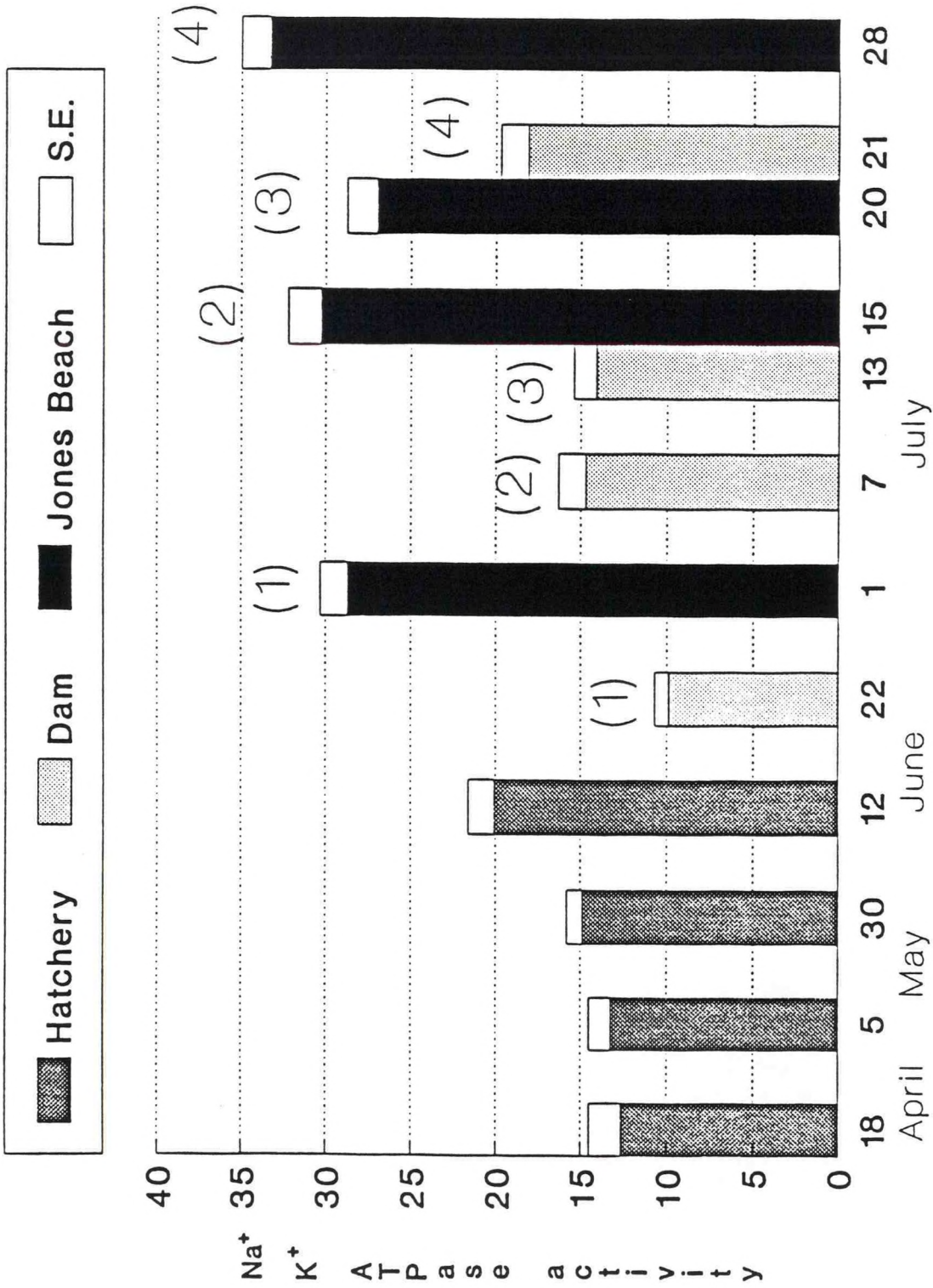

Figure 15.--Changes in gill Na⁺-K⁺ ATPase activity in subyearling chinook salmon at Bonneville Hatchery prior to release and following migration to Jones Beach, Bonneville Dam survival study, 1989. Units are micromoles ATP hydrolyzed per mg protein per hour. Numbers in parentheses indicate release series. Analysis by W. Zaugg (NMFS, Cook, Washington).

Table 3.--Numbers of descaled test fish among treatment groups of subyearling chinook salmon recovered at Jones Beach, Bonneville Dam survival study, 1989.

Release dates ^a	Recoveries											
	Upper turbine		Lower turbine		Bypass system		Frontroll		Spillway		Downstream	
	No.	% ^b	No.	%	No.	%	No.	%	No.	%	No.	%
22-24 June	2	0.41	0	0.00	0	0.00	0	0.00	0	0.00	2	0.47
6- 8 July	7	0.81	15	1.77	9	1.04	11	1.16	5	0.52	8	0.92
13-15 July	8	1.20	23	2.88	9	1.32	17	2.08	12	1.46	29	3.39
20-22 July	19	2.41	18	2.43	15	1.94	11	1.44	25	2.45	14	1.46
Total descaled	36		56		33		39		42		53	
Total recovered ^c	2,815		2,768		2,730		2,979		3,283		3,101	
Mean (%) ^d	1.28		2.02		1.21		1.31		1.28		1.71	

^a Fish released during early morning darkness.

^b % = (number of descaled fish recovered ÷ total number recovered) X 100.

^c Total fish with legible brands.

^d Mean descaled = (total descaled branded fish recovered ÷ total branded fish recovered) X 100.

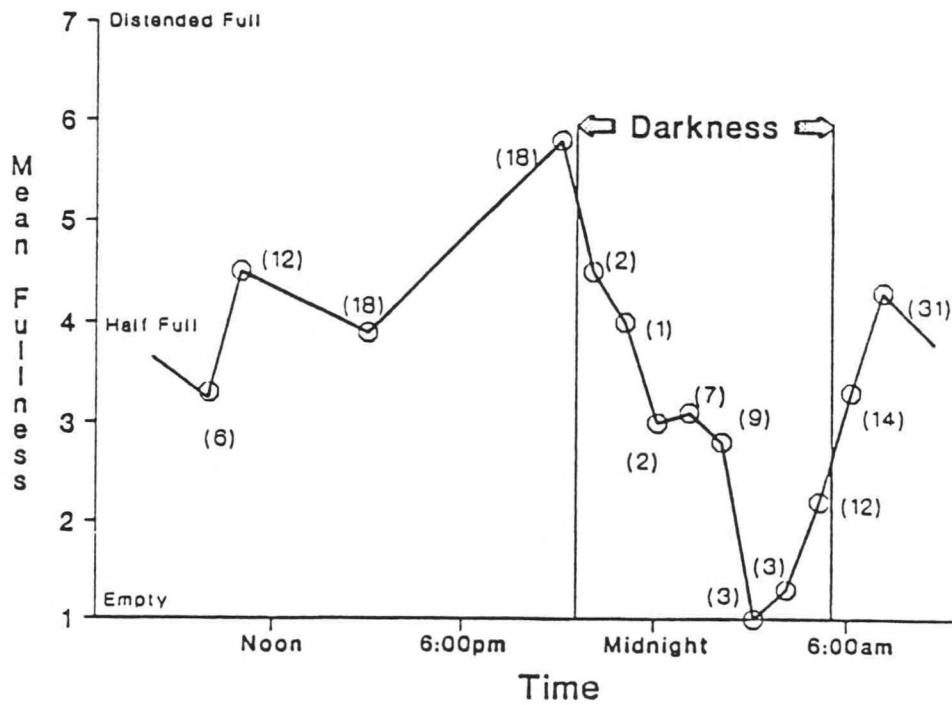
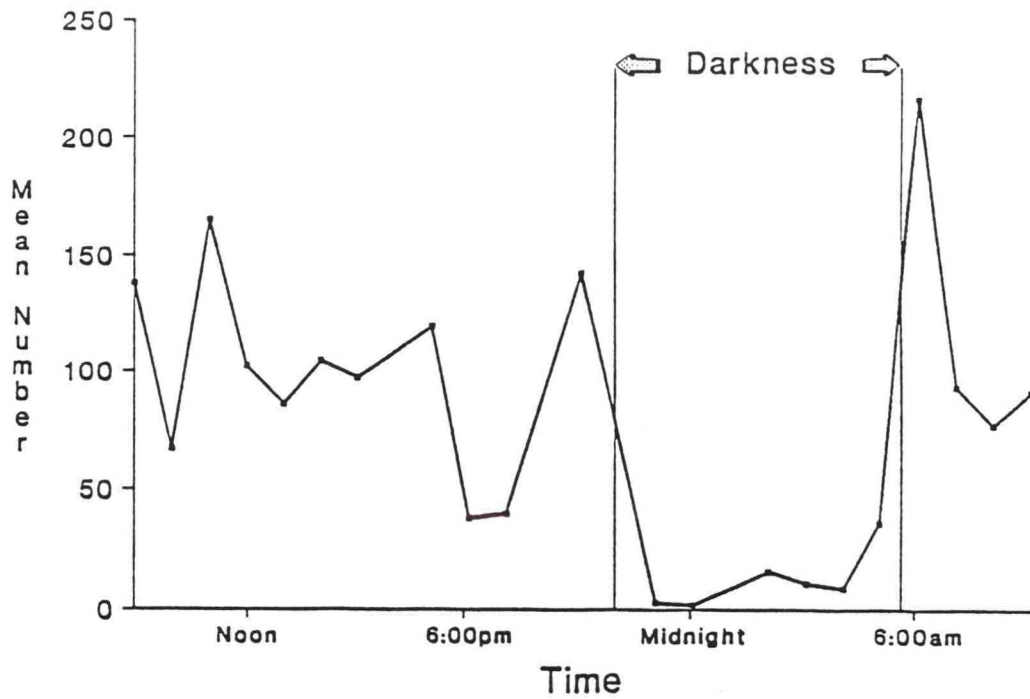

Figure 16.--Diel catch pattern and diel stomach fullness patterns of subyearling chinook salmon at Jones Beach, Bonneville Dam survival study, 1989. Sample size in parentheses.

(Fig. 16). This diel pattern of recovery was similar to that reported previously for subyearling chinook salmon during May and June at Jones Beach (Dawley et al. 1986).

Stomach Fullness and Diet Composition

Based on examination of selected marked fish for stomach fullness, study fish were feeding by the time they arrived at Jones Beach. Stomachs were generally about half full in fish collected during daylight hours; this finding is consistent with observations at Jones Beach in past years (Dawley et al. 1986). Feeding activity appeared to peak at sunset, then declined steadily throughout the night (Fig. 16). Although these data were useful since they suggest normal feeding behavior by the test fish, sample sizes were too small to meaningfully assess differences in fullness among treatments groups.

Analysis of stomach contents showed Insecta and Crustacea were the dominant prey items identified in the diet of the test fish (Appendix Table C4). Of these two groups, Diptera and Cladocera were the most common taxa. This finding is similar to that observed previously in subyearling chinook salmon recovered at Jones Beach (Kirn et al. 1986). Although numbers of prey items fluctuated considerably, there were no apparent diel differences in diet composition.

Juvenile Recovery Differences

Statistical analyses of CWT-fish recoveries at Jones Beach (Appendix E) indicated that there were significant differences

($\alpha = 0.05$) in mean recovery percentages among the various treatment groups (Table 4). Rank order (from lowest to highest) was bypass, lower turbine, upper turbine, frontroll, downstream, and spillway, with mean recovery percentages of 0.80, 0.83, 0.83, 0.86, 0.91, and 0.96, respectively. Recovery percentages for the spillway groups were significantly greater than all the other groups except the downstream groups. Recovery percentages for the downstream groups were significantly greater ($\alpha = 0.05$) than recovery percentages for the bypass and turbine groups, but not different from the frontroll groups. The differences in recovery percentages of the frontroll, turbine, and bypass groups were not significant.

The release schedule was advanced by 1 week which forced sampling in conjunction with dredging operations along the Jones Beach reach, which extended to 5 July. These complications resulted in lower than anticipated sampling effort for the first release series and lower recovery percentages than for other releases. Purse seine recovery data, standardized to an 18-set per day effort (Appendix Table C2) was also statistically analyzed. Conclusions regarding differences among mean recovery percentages derived from the standardized data were similar to those reached from the raw data (Fig. 17).

Since it was not possible to release all Second Powerhouse treatment groups simultaneously (i.e., upper turbine, lower turbine, bypass, and frontroll), the effect of release time on recovery percentage was evaluated statistically (Appendix E). We compared

Table 4.--Recovery percentages of tagged subyearling chinook salmon at Jones Beach, Bonneville Dam survival study, 1989.

Release date ^a	Upper turbine	Lower turbine	Bypass system	Frontroll	Spillway	Downstream
22 June ^b	0.5151	0.4309	0.5361	0.5277	0.6187	0.3262
23 "	0.5631	0.4581	0.4809	0.5314	0.5456	0.5583
24 "	0.5634	0.4992	0.4746	0.5351	0.5745	0.4576
6 July	1.1315	1.0367	0.9578	1.1706	1.0877	1.0684
7 "	1.0493	1.0842	1.0455	1.1131	1.2215	1.1337
8 "	0.9984	0.9682	1.0255	0.9773	1.0881	1.0408
13 "	0.8355	0.8917	0.8511	1.0181	0.9691	1.0385
14 "	0.7887	0.9217	0.8574	0.9745	0.9282	1.0476
15 "	0.8419	0.9650	0.6778	0.9159	1.0183	1.0103
20 "	1.0154	0.8527	0.9732	0.9501	1.1909	1.1073
21 "	0.8613	0.8900	0.8689	0.8541	1.1140	1.1090
22 "	0.7935	0.9092	0.8598	0.7968	1.1681	0.9751
Mean ^{cd}	0.8298	0.8256	0.8007	0.8637	0.9604	0.9061
Total released ^e	354,971	356,122	353,568	352,384	349,764	356,542
Total recovered ^f	2,950	2,943	2,836	3,051	3,375	3,230

^a Fish were released during early morning darkness.

^b The release schedule was advanced by 1 week which forced sampling in conjunction with dredging operations along the Jones Beach reach, which extended to 5 July. These complications resulted in lower than anticipated sampling effort for the first release series and lower recovery percentages than for other releases.

^c Weighted equally by block (i.e., by release day).

^d Empirical standard error = $\sqrt{\text{MSE} \div n}$; MSE (mean square error) from randomized block ANOVA; n = number of blocks; SE = 0.0224, all treatments.

^e Adjusted for tag loss.

^f Observed catch, purse seine plus beach seine.

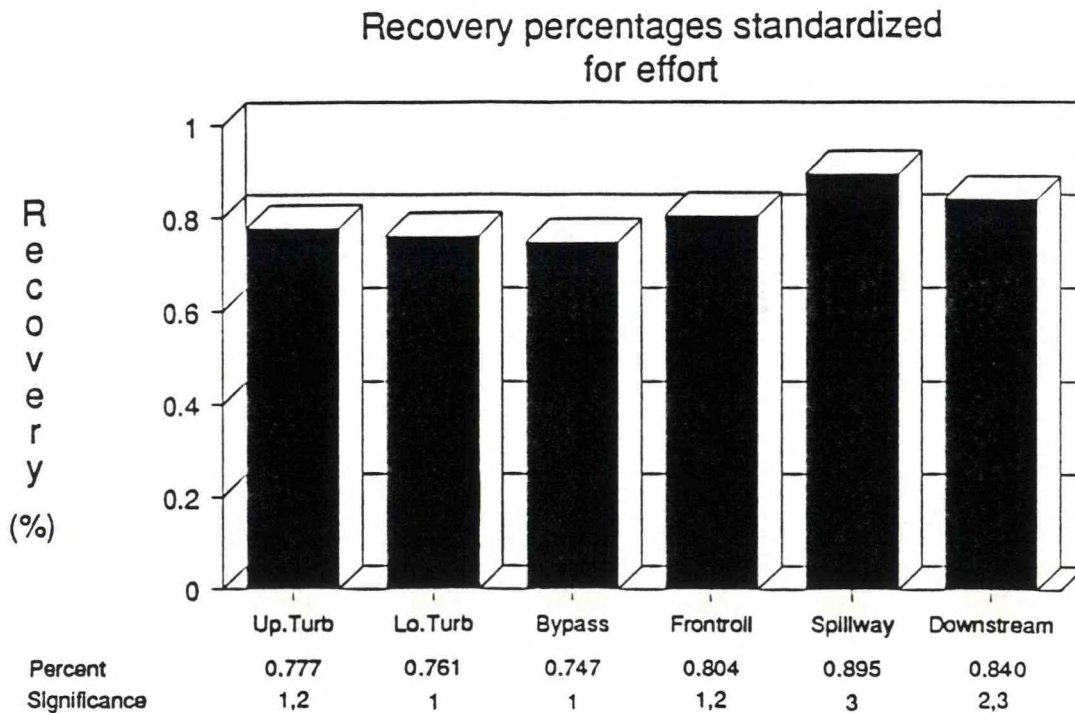
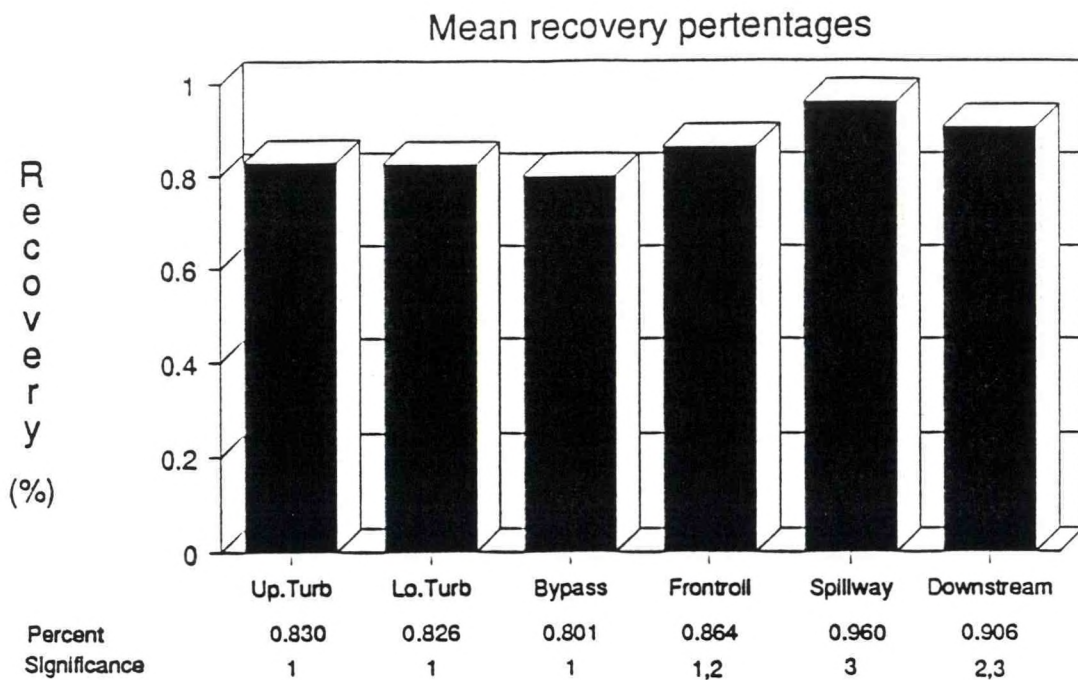

Treatment Groups

Figure 17.--Mean recovery percents, both observed catch and catch standardized for sampling effort, for treatment groups of tagged subyearling chinook salmon following migration to Jones Beach, Bonneville Dam survival study, 1989. Recovery percentages of groups identified by a common number in the "significance" row are not significantly different from one another at $\alpha = 0.05$.

the 12 lots of recovery data (i.e., by release date) for differences between first and last release times (0200 vs. 0230 h). The null hypothesis (i.e., there was no significant difference between recoveries from first vs. last releases) was not rejected for two point-source releases (bypass and frontroll) ($t = -1.1147$, $P = 0.2887$), and two broadcast releases (upper and lower turbine) ($t = 0.7037$, $P = 0.4962$). (Note: The data used for the analysis of release-time effect for the 1988 study [Dawley et al. 1989] were incorrect and subsequent analysis indicated that, as in 1989, there were no significant differences in first and last recoveries of point-source or broadcast releases).

Adult Recoveries

Tag data from adult recoveries were compiled for 2-year-old precocious males (jacks) released as subyearlings in 1987 and recovered in 1988. The total number (256) was not sufficient to meaningfully evaluate statistical difference among treatments. We expect to receive tag data from 3-year-old fish (1987 release) and 2-yr-old fish (1988 release) recovered at Bonneville Hatchery and from the river fishery starting about February 1990. When those data are compiled, a preliminary analysis will be prepared.

DISCUSSION

Multi-year Comparisons

The completion of juvenile releases and estuarine recoveries in 1989 marked the first opportunity to evaluate multi-year differences

in relative survival among the passage routes. Although these data should be viewed with caution, since adult returns are considered the ultimate measure of survival and hence passage success, some important trends were apparent (Table 5). Perhaps the most important of these were 1) test fish passing through the bypass system were recovered in significantly lower percentages than fish passing through the turbines, 2) upper vs. lower turbine releases showed no significant differences, and 3) spillway-released test fish had the highest recovery percentages (1 year of data only).

An important factor to consider when evaluating these data, particularly the between-year differences observed in bypass survival in relation to the other routes of passage, is the effect of tailwater height. Water velocity within the 0.9-m (3-ft) diameter bypass conduit increases from about 7.6 m/sec (24.9 ft/sec) at 5 m (16.4 ft) tailwater elevation to about 8.3 m/sec (27.2 ft/sec) at 3 m (9.8 ft) tailwater elevation (personal communication, Richard Waits, COE, Portland District, Portland, Oregon). If direct or delayed mortality was a function of increased velocity in the conduit, then the substantially higher tailwater elevations during tests conducted in 1989 (5.0 to 5.3 m [16.4 to 17.4 ft] compared to 2.7 to 4.1 m [8.9 to 13.5 ft] for 29 of 32 total releases in 1987 and 1988), would have resulted in reduced velocity in the conduit, and higher recovery percentages in relation to other passage routes. Fish released into the bypass did have higher relative recovery percentages in 1989 compared to 1987 and 1988. However, the first three releases in 1988 were conducted with

Table 5.--Summary of juvenile recovery percentages and percentage differences among selected groups, Bonneville Dam survival study, 1987-1989.

Treatment	Combined comparisons ^a				
	1987	1988	1989	(1988-89)	(1987-89)
	Percentages recovered ^b				
Bypass	0.5764 ¹	0.4376 ¹	0.8007 ¹	0.6191 ¹	0.6118 ¹
Upper turbine	0.6402 ^{1,2}	0.5024 ²	0.8298 ¹	0.6732 ²	0.6673 ²
Lower turbine	0.6528 ²	0.5104 ²	0.8256 ¹	0.6680 ²	0.6654 ²
Frontroll	nt ^c	0.5095 ²	0.8637 ^{1,2}	0.6866 ²	- ^d
Downstream	0.5567 ^e	0.5690 ³	0.9061 ^{2,3}	0.7376 ³	-
Spillway	nt	nt	0.9604 ³	-	-
	Percentage difference from bypass ^f				
Upper turbine	11 ^g	15*	4	9*	9*
Lower turbine	13*	17*	3	8*	9*
Frontroll	nt	16*	8	11*	-
Downstream	*	30*	13*	19*	-
Spillway	nt	nt	20*	-	-
	Percentage difference from frontroll ^h				
Bypass	-	-14*	-7	-10*	-
Upper turbine	-	-1	-4	-2	-
Lower turbine	-	0	-4	-3	-
	Percentage difference from downstream ⁱ				
Frontroll	nt	-10*	-5	-7*	-
Spillway	nt	nt	6	-	-

^a Combined using 5, 12, and 12 replicate blocks for 1987, 1988, and 1989, respectively. Upper turbine group in 1988 had one missing block.

^b In a given year, or combination of years, the same superscript number indicates no significant difference in recovery percentage (ANOVA, $\alpha = 0.05$). Mean recovery percentages are weighted by date of release--different from the means weighted by number of fish used in 1987 and 1988 annual reports.

^c nt = not tested.

^d Incomplete data.

^e The downstream release in 1987 was made at the shoreline. Subsequently, lower recovery percentages of that treatment led to an *a posteriori* decision to not use these data for assessing relative survival of the treatments which were released away from the shoreline.

^f Calculated using annual means for recovery percent of bypass (BY):
 $[(BY\% - \text{treatment}\%) \div BY\%] \times 100$.

^g Asterisk indicates significant difference at $\alpha = 0.05$.

^h Calculated using annual means for recovery percentage of frontroll (FR):
 $[(FR\% - \text{treatment}\%) \div FR\%] \times 100$.

ⁱ Calculated using annual mean for recovery percent of downstream (DS):
 $[(DS\% - \text{treatment}\%) \div DS\%] \times 100$.

tailwater elevations ranging from 4.3 to 4.6 m (14.1 to 15.1 ft), and recovery differences among test groups released on these days were no different from recovery differences of the bypass fish groups observed at lower tailwater elevations and thus higher conduit water velocities.

Increased tailwater elevation in 1989 also increased submergence and decreased the hydraulic head of the turbine blade which theoretically should increase turbine passage survival (Bell et al. 1981). Results of this study showed a non-significant 3-4% decrease in relative recovery percentage for turbine groups compared to frontroll groups (Table 5). However, flow through the turbine was altered to maintain maximum efficiency (range 92 to 92.5%) during all tests. This was based on the work of Oligher and Donaldson (1965) and Bell et al. (1981) who concluded turbine efficiency was positively correlated with fish survival. Accordingly, the influence of tailwater height on these results is unknown.

Fish passing through turbines close to the hub of the blade are believed to have the highest survival potential compared to those passing by other areas of the blade. The basis of this difference is the lower probability of the blade striking a fish, and lower shear forces (Long and Marquette 1964). At Bonneville Dam Second Powerhouse, water passing through the upper portion of the turbine intake, where upper turbine test fish were released, passes closest to the hub (personal communication, Brian Moentenich, COE, North Pacific Division, Portland, Oregon). Thus, comparison of relative survival of the upper turbine and lower turbine releases should have

provided a measure of this theoretical survival difference. However, recovery percentages over all 3 years of this study indicated no significant differences; the difference between lower and upper turbine recoveries for the combined data was less than 0.5%. Since the potential for being struck by a blade can be mathematically related to fish size (Monten 1955; Von Raben 1957), differences in survival related to turbine passage location at Bonneville Dam may be more apparent in larger fish such as yearling salmonids.

An important objective of the study that was addressed for the first and only time in 1989 was the assessment of relative survival of fish passing Bonneville Dam via the spillway. Recovery percentages of spillway-released groups in the estuary were higher than all other released groups and even exceeded the downstream groups in 9 of 12 instances. Among the more likely explanations for the higher recoveries from the spillway groups compared to the downstream groups were that 1) the spill caused high turbulence and flow such that test fish (and potential predators) were widely dispersed upstream from the downstream release location and 2) squawfish predation immediately downstream from the spillway was lower than in the Second Powerhouse tailrace. With regard to 2), we believe the minimal operation of the spillway prior to testing (2.5 hours prior to and 5.5 hours after release, with no spill on non-test days) provided little incentive for predators to inhabit the spillway tailrace. In contrast, during the second half of the survival study, the Second Powerhouse turbines were operated 6 hours

per night for fish guidance studies (being conducted by other researchers) 3 or 4 days in advance of survival study releases and likely attracted more predators (Appendix Table F1).

Comparison of multi-year differences among recovery percentages of selected release groups can be used to estimate effects of different passage routes on overall passage survival. For example, differences between recovery percentages of the frontroll groups (released 30 m downstream from the dam) and the groups which passed through the Second Powerhouse provide an estimate of the effects of turbine and bypass passage on survival. As shown in Table 5, mean recovery percentages of bypass-, upper turbine-, and lower turbine-passage groups (combined data from 1988 and 1989) were 10, 2, and 3% lower, respectively, than the frontroll groups. Likewise, comparisons of differences between recovery percentages of the frontroll groups and the downstream groups provide an estimate of the effects of passage through the 2.5 km of tailrace and river downstream from the Second Powerhouse on survival. The 1988 and 1989 combined mean recovery percentages of frontroll-released fish was about 7% lower than the combined mean recovery percentages of downstream released fish.

Differences in recovery percentages between groups released at the Second Powerhouse and downstream groups increased through time. For marked lots from the first two release series, recovery percentages of groups released at the dam exceeded the downstream groups in 11 of 24 comparisons; this occurred in 0 of 24 comparisons during the last two 8 release series. A similar pattern was evident

in 1987 and 1988 (Appendix Tables G1 and G2). One explanation for this pattern is there may have been greater predation on test fish by squawfish during the later release periods. Several factors support this possibility: 1) populations of predators may have increased along with waterflows through the Second Powerhouse as a result of fish guidance efficiency tests conducted during the second half of the survival study releases (Appendix Table F1);

2) Uremovich et al. (1980) reported a decline in squawfish abundance in the vicinity of Bonneville Dam during June and early July followed by a rapid increase in abundance in mid-July and August;

3) Vigg et al. (1988) reported that June is the spawning period for squawfish in the John Day reservoir and that while spawning, squawfish consume less food; and 4) food consumption increases with increased water temperature (Vigg et al. 1988). All of these factors probably contributed to a situation in which the later release lots may have been subjected to higher predation than earlier lots, and the downstream groups may have escaped this predation by being released in fast-flowing water downstream from the dam.

In 1989, movement rates of study fish to the estuary were similar to those observed in 1988, which were two to three times faster than in 1987. Since river flows (Appendix Fig. C3) and the degree of smoltification (as indicated by levels of $\text{Na}^+\text{-K}^+$ ATPase activity in fish prior to release and at recovery in the estuary) were similar in all 3 years, the increased rates of migration in 1988 and 1989 were probably due to the larger size of the test fish

and their tendency for mid-river migration. As a consequence of the slower migration and smaller size, we suspect that 1987 study fish were subjected to more predation in fresh water resulting in lower survival to the ocean.

Significant differences in percentages of descaled fish among treatment groups (from estuarine recoveries) were not observed in 1989 or any previous year. Moreover, the low observed prevalence (generally less than 3%) of descaled fish was consistent with previous observations of hatchery fish recovered at Jones Beach (Dawley et al. 1986). Taken together with the knowledge that not all descaled fish die and that fish showing signs of scale regeneration are frequently recovered at Jones Beach, these data suggest that descaling was not a serious problem at any of the dam passage routes.

Assumptions

Between 1966 and 1983, the recovery percentages of downstream migrant salmonids in the estuary were used to estimate relative survival (Dawley et al. 1986). However, to make the transition between recovery percentages and survival in the present study several assumptions were made. Some of those assumptions are as follows:

- 1) Release groups were identical except for the treatment (e.g., size, health, degree of smoltification, and handling).
- 2) Errors in mark application and identification were minimal compared to treatment differences.

- 3) Differences in release procedures among treatments had minimal effect on survival (e.g., release-hose hydraulic head and exit conditions) compared to treatment differences.
- 4) Differences in release time into the tailrace had minimal effects on survival compared to treatment differences.
- 5) Differences in vertical and lateral distribution within the river downstream from the downstream release site had minimal effects on survival compared to treatment differences.
- 6) Probability of recovery was equal for all treatment groups (groups were thoroughly mixed as they passed the sampling site).

In the present study, we feel confident that these assumptions were met. Care was taken to mark all treatments simultaneously and to provide identical handling after marking. Release conditions were standardized to the extent possible and differences appear minor. Among groups released the same day, there was little evidence of differences in riverine/estuarine distribution, timing, or fish size or condition at recovery:

- 1) In 1987, beach seine catch results from three beach sites (Oregon, Washington, and mid-river island shorelines) showed that there was no statistical difference between sites for the proportions of each treatment recovered (Chi-square = 11.896, $P = 0.2920$; Appendix E).
- 2) Statistical evaluation of recovery timing differences among treatments indicated no difference for 1988 or 1989 (data pooled by year), but in 1987, two of five data blocks were significantly

different ($\alpha = 0.05$; Appendix E); we have no explanation for this apparent departure from the expected recovery distribution.

- 3) There was no apparent difference in daily mean fork lengths, descaling, or injuries among treatments throughout the 3 years of estuarine sampling.

These results appear to confirm adequate mixing of study fish at Jones Beach, with the possible exception of some 1987 recoveries.

Data Relevance

Although the results of the first 3 years of this study indicate a bypass-associated survival problem at the Second Powerhouse, juvenile assessment is only one component of the overall assessment--the results from adult recoveries are equally important. Also, point estimates were made which only relate to effects on hatchery fall chinook salmon passing Bonneville Dam during the summer of 3 years when operation of the Second Powerhouse and spillway was limited. Test fish size and behavior, predator populations, and tailrace conditions may influence survival of fish using the different passage routes, and could alter the relative survival differences found in this study.

Passage survival of subyearling chinook salmon taken directly from the hatchery may not be representative of survival of highly smolted, river-run migrants or yearling-sized fish. Smolted fish are generally more sensitive to handling stress than non-smolted fish, and any physical trauma during passage might have more profound effects on the survival of actively smolting fish. Also,

larger yearling salmonids may exhibit survival differences during passage through the dam compared to the smaller subyearling fish we tested. This supposition is based on 1) the assumption that larger fish are less likely to be preyed upon if disoriented following dam passage (theorized from prey size selectivity of squawfish; Poe et al. 1988); 2) the results of previous studies that indicate that shear force injuries decrease in relation to fish size, within the salmonid smolt size range (Groves 1972); and 3) the findings of two previous turbine survival studies in which different-sized fish were released and survival percentages were compared. In both of these studies, the estimated survival percentages were greater for larger fish, although not significantly so (i.e., 91 vs. 88% estimated survival for yearling chinook salmon, about 125 mm fork length, vs. subyearling chinook salmon, about 60 mm--size inferred from testing date--passing through Kaplan turbines at Big Cliff Dam [Schoeneman et al. 1961]; 96.7 vs. 93% estimated survival for steelhead, about 175 mm fork length, vs. coho salmon, about 120 mm, passing through bulb turbines at Rock Island Dam [Olson and Kaczynski 1980])). Also, larger fish theoretically have a greater probability of injury from blade strike and cavitation injury because of their larger body size (Monten 1955; McGrath 1956).

Another consideration is that, at water flows different from those tested, the effects of passage through the tailrace may be considerably different due to differences in fish migration routes and the size and location of predator populations. However, model

studies at WES, comparing water flow direction and velocities for an eight-turbine operation vs. the four-turbine operation (Appendix Figs. H1 and H2), indicated only slight differences at the location of fish releases. Accordingly, we would anticipate that migration routes through the tailrace basin would be similar at both flows. Additional model studies of flow patterns using dye with the eight- or four-turbine configuration (personal communication, John Ferguson, COE, Portland District, Portland, Oregon) indicated 1) at both flows, dye released at locations of test fish releases did not move into the middle area of the tailrace where there was a large back eddy and 2) effects of increasing the turbine flow from four units (as used in this study) to eight units caused water flows from the release locations to travel closer to the Washington shoreline. Velocity measurements made at Bonneville Dam in March 1988 (four turbines operating) provided data similar to model data (Appendix Figs. I1 and I2). Thus, the increased flow resulting from an eight-turbine operation could have a negative rather than positive impact on survival, assuming that heavier predation would occur in association with nearshore migration.

CONCLUSIONS

The following conclusions are based on 3 years of estuarine recoveries of juvenile salmonids released at Bonneville Dam. It cannot be over emphasized that these conclusions are valid only for the species and size of fish tested (subyearling chinook salmon)

and the dam passage conditions and river environment which occurred during testing. Other fish species or other sizes of chinook salmon passing through the dam at other times of the year may have substantially different survival levels. Moreover, these conclusions are preliminary pending assessment of treatment group differences among adults recovered over the next 5 years.

- 1) Recovery differences among treatment groups appear to represent passage survival differences; marking, release, and recovery procedures did not influence recovery differences; assumptions which could be assessed were met and, on the basis of consistency of annual recovery patterns, we believe unassessed assumptions were likewise met.
- 2) Estuarine sampling of juveniles provided recovery data to make statistical comparisons among treatment groups that are as sensitive as comparisons from expected adult recovery data; the lack of differences in catch distributions among treatment groups suggests uniform sampling of all treatment groups.
- 3) Results from the estuarine sampling suggest that transporting the downstream release groups from the shoreline (site used in 1987) to mid-river (site used in 1988 and 1989) provided a more appropriate comparison group to groups released at the dam. The shoreline releases in 1987 were apparently more severely impacted by predators inhabiting shoreline areas than those groups released at the dam in mid-river locations. The change in release site was an important improvement in experimental

design and allowed us to estimate mortality in the river immediately downstream from the Second Powerhouse and Spillway.

- 4) Fish released in the bypass had significantly lower survival than all other treatment groups.
- 5) Differences in survival between lower and upper turbine releases were not detectable.
- 6) The decrease in recovery percentage associated with passage through the tailrace downstream from the Second Powerhouse was of greater magnitude than the decreases associated with passage through the turbines, particularly for fish released after early July. We speculate that predation by squawfish is the causative factor.
- 7) Fish released through the spillway had a significantly higher mean recovery percentage than fish passing through the Second Powerhouse turbines or bypass system (based on data from 1989 only).
- 8) Few descaled study fish (less than 3% of the total) were captured at Jones Beach, and there was no apparent relationship with the treatments tested.

RECOMMENDATIONS

- 1) Tag recovery data from adults should be compiled through 1994 to obtain the maximum amount of data for assessing passage survival differences.

- 2) Comparisons of juvenile recovery data to adult recovery data should be made.
- 3) Research should be initiated immediately to determine the causes of apparent diminished survival resulting from passage through the Bonneville Second Powerhouse bypass system.

REFERENCES

- Allis-Chalmers Corp.
1978. Bonneville Second Powerhouse model test report. U.S. Army Corps of Engineers, Portland, OR. 400 p.
- Bell, M. C., A. C. DeLacy, and G. J. Paulik.
1981. A compendium of the success of passage of small fish through turbines. Section I. In Updated compendium on the success of passage of small fish through turbines. Report to U.S. Army Corps of Engineers, Contract DACW-68-76-C-0254. 204 p.
- Bergman, P. K., K. B. Jeffords, H. F. Fiscus, and R. C. Hager.
1968. A preliminary evaluation of an implanted coded wire fish tag. Wash. Dep. Fish., Fish. Res. Pap. 3(1):63-84.
- Buchanan, D. V., R. M. Hooton, and J. R. Moring.
1981. Northern squawfish (Ptychocheilus oregonensis) predation on juvenile salmonids in sections of the Willamette River Basin, Oregon. Can. J. Fish. Aquat. Sci. 38:360-364.
- Cramer, Frederick K.
1965. Fish passage through hydraulic turbines. U.S. Army Corps of Engineers, Walla Walla District, Memorandum report. March 31, 1965.
- Dawley, E. M., L. G. Gilbreath, and R. D. Ledgerwood.
1988. Evaluation of juvenile salmonid survival through the second powerhouse turbines and downstream migrant bypass system at Bonneville Dam, 1987. Report to U.S. Army Corps of Engineers, Contract DACW57-87-F-0323, 36 p. plus Appendix. (Available from Northwest Fisheries Center, 2725 Montlake Blvd. E., Seattle, WA 98112-2097.)
- Dawley, E. M., L. G. Gilbreath, R. D. Ledgerwood, P. J. Bentley, B. P. Sandford, and M. H. Schiewe.
1989. Survival of subyearling chinook salmon which have passed through the turbines, bypass system, and tailrace basin of Bonneville Dam Second Powerhouse, 1988. Report to U.S. Army Corps of Engineers, Contract DACW57-87-F-0323, 78 p. (Available from Northwest Fisheries Center, 2725 Montlake Blvd. E., Seattle, WA 98112-2097.)

Dawley, E. M., R. D. Ledgerwood, T. H. Blahm, C. W. Sims, J. T. Durkin, R. A. Kirn, A. E. Rankis, G. E. Monan, and F. J. Ossiander.

1986. Migrational characteristics, biological observations, and relative survival of juvenile salmonids entering the Columbia River estuary, 1966-1983. Report to Bonneville Power Administration, Contract DE-A179-84BP39652, Project 81-102, 256 p. (Available from Northwest Fisheries Center, 2725 Montlake Blvd. E., Seattle, WA 98112-2097.)

Dawley, E. M., R. D. Ledgerwood, and A. L. Jensen.

1985. Beach and purse seine sampling of juvenile salmonids in the Columbia River estuary and ocean plume, 1977-1983. Volume I: Procedures, sampling effort, and catch data. U.S. Dep. of Commer., NOAA Tech. Memo. NMFS N/NWC-74:1-260.

Fisher, R. A.

1944. Statistical methods for research workers, 9th edition. Oliver and Boyd, LTD, London. 350 p.

Faler, M. P., L. M. Miller, and K. I. Welke.

1988. Effects of variation in flow on distributions of northern squawfish in the Columbia River below McNary Dam. N. Amer. J. Fish. Manage. 8:30-35.

Gessel, M. H., B. H. Monk, D. A. Brege, and J. G. Williams.

1989. Fish guidance efficiency studies at Bonneville Dam first and second powerhouses - 1988. Report to U.S. Army Corps of Engineers, Contract DACW57-87-F-0322, 36 p. plus Appendix. (Available from Northwest Fisheries Center, 2725 Montlake Blvd. E., Seattle, WA 98112-2097.)

Gessel, M. H., D. A. Brege, B. H. Monk, and John G. Williams.

1990. Continued studies to evaluate the juvenile bypass systems at Bonneville Dam-1989. Report to U.S. Army Corps of Engineers, Project E8689095, 19 p. plus Appendix. (Available from Northwest Fisheries Center, 2725 Montlake Blvd. E., Seattle, WA 98112-2097.)

Groves, A. B.

1972. Effects of hydraulic shearing actions on juvenile salmon. U.S. Dep. of Commer., Natl. Oceanic and Atmos. Admin., Natl. Mar. Fish. Serv., Northwest Fish. Cent., Seattle, WA. 7 p.

Holmes, H. B.

1952. Loss of fingerlings in passing Bonneville Dam as determined by marking experiments. U.S. Fish and Wildlife Service, unpublished manuscript. 62 p.

Jensen, A. L.

1987. Bonneville Dam Second Powerhouse fish guidance research; velocity mapping studies. Report to U.S. Army Corps of Engineers, Contracts DACW57-85-H-001 and DACW57-86-F-0541, 186 p. (Available from Northwest Fisheries Center, 2725 Montlake Blvd. E., Seattle, WA 98112-2097.)

Krcma, R. F., D. DeHart, M. H. Gessel, C. W. Long, and C. W. Sims.
1982. Evaluation of submersible traveling screens, passage of juvenile salmonids through the ice-trash sluiceway, and cycling of gatewell-orifice operations at Bonneville First Powerhouse. Final report to U.S. Army Corps of Engineers, Contract DACW57-81-F-0343, 36 p. plus Appendixes. (Available from Northwest Fisheries Center, 2725 Montlake Blvd. E., Seattle, WA 98112-2097.)

Kirn, R. A., R. D. Ledgerwood, and A. L. Jensen.

1986. Diet of subyearling chinook salmon (Oncorhynchus tshawytscha) in the Columbia River estuary and changes effected by the 1980 eruption of Mount St. Helens. Northwest Science 60:191-196.

Long, C. W., and W. M. Marquette.

1964. Program of research on fingerling passage problems associated with Kaplan turbines, 1962-1964. Fish-Passage Research Program, U.S. Bureau of Commer. Fish., Seattle, WA. 7 p.

McGrath, C. J.

1956. Inland fisheries and the engineer. Reprinted from the Transactions of the Institution of Civil Engineers of Ireland 82:51-79.

Mighell, J. H.

1969. Rapid cold-branding of salmon and trout with liquid nitrogen. J. Fish. Res. Board Can. 26:2765-2769.

Monten, E.

1955. The possibility of salmon smolt passing unharmed through power plant turbines when descending to the sea. Translated from Swedish by the U.S. Joint Publication Service, for the Fish Passage Research Program, U.S. Bureau of Commercial Fisheries, Seattle, Washington. June 1963. (Original reference: "Om utvandrande laxunqars mōjligheter att oskadda passera genom Kraftverksturbines (preliminart meddelande). Laxforsknings-institutet, Bankagatan 8, Sundsvall, Sweden, Vandringsfiskutredningen, Meddelande Nr. 13, Stockholm. July 18, 1955.

Oligher, R. C., and I. J. Donaldson.

1965. Fingerling mortality versus turbine efficiency at Big Cliff Dam. U.S. Army Corps of Engineers versus turbine efficiency at Big Cliff Dam. U.S. Army Corps of Engineers, Walla Walla District.

Olson, F. W., and V. W. Kaczynski.

1980. Survival of downstream migrant coho salmon and steelhead trout through bulb turbines. CH₂M Hill. Report to Public Utility District No.1 of Chelan County, Wenatchee, WA. 45 p. plus appendixes.

Petersen, R. G.

1985. Design and analysis of experiments. Marcel Dekker, Inc., New York, NY. 429 p.

Poe, T. P., H. C. Hansel, S. Vigg, D. E. Palmer, and L. A. Pendergast.

1988. Predation by northern squawfish, walleye, smallmouth bass, and channel catfish in mainstem Columbia River Reservoir: feeding ecology during the salmonid smolt out-migration. In: T. P. Poe and B. E. Reiman (editors), Predation by resident fish on juvenile salmonids in John Day reservoir, 1983-1986. Oregon Dept. Fish and Wildlife. 1:13-55. (Final Report to Bonneville Power Administration, Portland, OR 97208, by U.S. Fish and Wildlife Service and Oregon dept. Fish and Wildlife. Contracts DE-AI79-82BP34796 and DE-AI79-82BP35097.)

Schoeneman, D. E., R. T. Pressey, and C. O. Junge.

1961. Mortalities of downstream migrant salmon at McNary Dam. Trans. Amer. Fish. Soc. 90(1):58-72.

Smith, K. E. H.

1961. Mortality tests, yearling gaspereau, at Tusket River Power Dam, Yarmouth County, Nova Scotia. Canada Department of Fisheries.

Sokal, R. R., and F. J. Rohlf.

1981. Biometry, 2nd. Edition. W.H. Freeman and Company, San Francisco, CA. 776 p.

Terry, C.

1977. Stomach analysis methodology: still lots of questions. In: C. A. Simenstad and S. J. Lipovsky (eds), Fish food habits studies: 1st Pacific Northwest Technical Workshop, Proceedings, October 13-15, 1976, University of Washington, Div. Mar. Resources, Sea Grant, WSG-WO 77-2.

Thompson, R. B.

1959. Food of the squawfish (Ptychocheilus oregonensis Richardson) of the lower Columbia River. Fish. Bull. 158:43-58.

Thompson, R. B., and D. F. Tufts.

1967. Predation by Dolly Varden and northern squawfish on hatchery reared sockeye salmon in Lake Wenatchee, Washington. Trans. Amer. Fish. Soc. 96:424-427.

Uremovitch, B. L., S. P. Cramer, C. F. Willis, and C. O. Junge.

1980. Passage of juvenile salmonids through the ice-trash sluiceway and squawfish predation at Bonneville Dam, 1980. Research and Development Section, Oregon Dept. Fish and Wildlife. Annual Progress Report to U.S. Army Corps of Engineers, Contract DACW57-78-C-0058, 46 p.

Von Raben, K.

1964. Regarding the problem of mutilation of fishes by hydraulic turbines. (Translation from the German, "Zur Frage de Beschädigung von Fischen durch Turbinen." Die Wasserwirtschaft, No. 4:97-100. 1957.) Translation by the Fisheries Research Board of Canada, Translation Series, No. 448.

Vigg, S., T. P. Poe, L. A. Prendergast, and H. C. Hansel.

1988. Predation by resident fish on juvenile salmonids in a mainstem Columbia River reservoir: Part II. Consumption rates of northern squawfish, walleye, smallmouth bass, and channel catfish. In T. P. Poe and B. E. Reiman (editors), Predation by resident fish on juvenile salmonids in John Day reservoir, 1983-1986. Oregon Dept. Fish and Wildlife. 1:56-115. (Final Report to Bonneville Power Administration, Portland, OR 97208, by U.S. Fish and Wildlife Service and Oregon Dept. Fish and Wildlife. Contracts DE-AI79-82BP34796 and DE-AI79-82BP35097).

Zar, J. H.

1974. Biostatistical analysis. Prentice-Hall, Inc. Englewood Cliffs, NJ. 620 p.

Zaugg, W. S., and L. S. McLain.

1970. Adenosine triphosphatase activity in gills of salmonids: seasonal variation and saltwater influence in coho salmon, Oncorhynchus kisutch. Comp. Biochem. Physiol. 35:587-596.

APPENDIX A

Turbine Characteristics

Appendix Table A1.--Physical and operational characteristics of turbines at Bonneville Dam's Second and First Powerhouses and McNary Dam.^a

Parameter	Bonneville Second	Bonneville First	McNary
Runner submergence (ft) (in relation to tailwater)	-18 to -53	-5 to -40	-23 to -30
Horsepower	110,000 @ 60' head	74,000 @ 60' head	111,300 @ 80' head
Discharge (ft ³ /sec)	17,600 @ 60' head	12,300 @ 60' head	14,000 @ 80' head
Runner type	Kaplan	Kaplan	Kaplan
Number of blades	5	5	6
Runner dim. (ft)	27.5	23.3	23.3
Runner speed (RPM)	69.2	75	85.7
Specific speed ^b	137.4 @ 60' head	122.2 @ 60' head	119.5 @ 80' head
Percent efficiency ^c (%)	92.5 @ 60' & 110,000 hp	90.8 @ 60' & 74,000 hp	90.0 @ 80' & 111,300 hp
Sigma ^d (@ 65°F)	0.93 @ 60' & TW=14'	0.70 @ 60', TW=14'	0.76 @ 80', TW=260'

^a For ease of understanding, these data are in English units; most data from COE, North Pacific Division, Portland, Oregon.

^b Calculated from the following: Specific Speed = (RPM x $\sqrt{\text{hp}}$) / Head^{5/4}.

^c Data derived from Figure 8-02.1 of expected prototype performance of Bonneville Second Powerhouse (Allis-Chalmers 1978), from Exhibit 2, and Exhibit 6 (Bell 1981) for Second Powerhouse, First Powerhouse, and McNary Dam, respectively.

^d

$$\text{Plant Sigma } (\sigma) = \frac{(\text{Atmospheric pressure}) - (\text{Water Vapor pressure}) - (\text{CL runner elev} - \text{TW elev})}{\text{Head Pressure}}$$

Where CL = center line and TW = tailwater.

APPENDIX B

Marking and Release Information: Tag Loss Estimates,
Test Conditions, and Release Sequence

Appendix Table B1.--Tag loss estimates among branded groups of subyearling chinook salmon after a 30-day holding period, Bonneville Dam survival study, 1989.

Release dates	Brand ^b	CWTs ^a			Sample size ^c	NCWT ^d	
		AGD1D2	AGD1D2	AGD1D2		No.	%
Upper turbine releases							
22-24 Jun	RD>H1	232656	232804	232816	373	12	3.2
6- 8 Jul	RD>H3	232828	232841	232852	369	7	1.9
13-15 Jul	LD>H1	233101	233113	233125	333	6	1.8
20-22 Jul	LD>H3	233137	233149	233161	330	0	0.6
Lower turbine releases							
22-24 Jun	RD>K1	232659	232807	232819	352	7	2.0
6- 8 Jul	RD>K3	232831	232842	232855	252	3	1.2
13-15 Jul	LD>K1	233102	233114	233126	316	5	1.6
20-22 Jul	LD>K3	233138	233150	233162	297	2	0.7
Bypass releases							
22-24 Jun	RD>L1	232661	232808	232821	275	9	2.5
6- 8 Jul	RD>L3	232832	232844	232856	251	3	1.2
13-15 Jul	LD>L1	233104	233116	233128	187	3	1.6
20-22 Jul	LD>L3	233141	233152	233201	234	5	2.1
Frontroll releases							
22-24 Jun	RD>U1	232662	232811	232822	443	19	4.3
6- 8 Jul	RD>U3	232835	232847	232859	425	6	1.4
13-15 Jul	LD>U1	233107	233119	233131	389	11	2.8
20-22 Jul	LD>U3	233142	233155	233202	480	6	1.3
Spillway releases							
22-24 Jun	RD>V1	232801	232813	232825	236	16	6.8
6- 8 Jul	RD>V3	232837	232849	232861	223	7	3.1
13-15 Jul	LD>V1	233108	233121	233132	224	2	0.9
20-22 Jul	LD>V3	233144	233156	233204	270	5	1.9
Downstream releases							
22-24 Jun	RD>X1	232802	232814	232826	432	5	1.2
6- 8 Jul	RD>X3	232838	232850	232862	455	10	2.2
13-15 Jul	LD>X1	233111	233122	233135	420	6	1.4
20-22 Jul	LD>X3	233147	233159	233207	444	1	0.1
Totals					8,010	156	

^a CWT = coded wire tag; where AG = agency code, D1 = data 1, D2 = data 2.

^b Brand position RD (right dorsal) or LD (left dorsal) followed by the letter brand symbol; the numbers 1 or 3 indicate brand rotation.

^c Number of branded fish checked for the presence of coded-wire tags.

^d NCWT = Number of branded fish in the sample with no coded wire tag.

Appendix Table B2.--Flow data, operating conditions, and water temperatures at the times of release for the 12 release dates of the Bonneville Dam survival study, 1989.*

Date	Second Powerhouse			Turbine 17			Spillway							
	Forebay elev. (ft)	Tailwater elev. (ft)	Flow (k·ft ³ /s)	Flow ^b (k·ft ³ /s)	Load (MW)	Head (ft)	Wicket gate (%)	Blade angle (°)	Plant sigma ^c (σ)	Estim. effi ^c . ^d (%)	Bypass downwell elev. (ft)	Tailrace elev. (ft)	Flow (k·ft ³ /s)	River temp. (°F)
22 Jun	73.7	17.3	58*	14.4	63	56.4	71	20.2*	1.04	92.5	56.5	16.6	53.0	62
23 Jun	75.0	16.4	60*	15.0	64	58.6	71	20.8*	0.99	92.5	57.0	15.5	53.0	63
24 Jun	73.3	17.3	57*	14.2	63*	56.0	71*	20.1*	1.05	92.5	56.0	16.0	53.0	63
6 Jul	74.2	16.8	64.5	15.3	68	57.4	76	23.0*	1.02	92.5	56.0	15.7	53.0	66
7 Jul	74.4	17.0	67.5	15.2	67	57.4	74	22.1*	1.02	92.0	55.5	16.0	53.0	66
8 Jul	73.1	17.0	65.6	15.2	66	56.1	76	22.7*	1.04	92.0	56.0	16.0	53.0	66
13 Jul	74.5	16.5	60.2	14.2	64	58.0	72	20.4*	1.00	92.5	57.0	15.6	53.0	67
14 Jul	74.0	17.2	56.8	14.8	65	56.8	73	21.5*	1.03	92.5	57.0	16.3	53.0	67
15 Jul	74.1	17.1	58.0	14.7	65	57.0	73	21.6	1.03	92.5	56.0	16.1	53.0	67
20 Jul	74.2	16.8	65.0	14.6	66	57.4	74	21.8	1.01	92.5	56.5	16.2	53.0	68
21 Jul	74.4	17.0	64.0	14.6	64	57.4	72	20.8	1.02	92.5	56.5	16.3	53.0	69
22 Jul	74.5	16.8	61.6	14.6	64	57.7	72	20.3	1.01	92.5	56.5	16.1	53.0	68

* English units are used for selected parameters by convention.

^b Discharge calculated from Figure 8.1-1 of Bonneville Second Powerhouse model test report, Allis-Chalmers (1978).

^c (Atmospheric) - (Water Vapor) - (CL runner elev - TW elev)
 Plant Sigma (σ) = $\frac{(\text{pressure}) - (\text{pressure})}{(\text{pressure differential})}$

Head Pressure

Where: CL = center line and TW = tailwater.

^d Data derived from Figure 8-02.1 of expected prototype performance of Bonneville Second Powerhouse (Allis-Chalmers 1978).

* Estimated.

Appendix Table B3.--Flow data, operating conditions, and water temperatures at the times of release for the 12 release dates of the Bonneville Dam survival study, 1988.^a

Date	Second Powerhouse			Turbine 17			Bypass downwell elevation (ft)	River temp. (°F)		
	Forebay elev. (ft)	Tailrace elev. (ft.)	Flow ^b (k-ft ³ /s)	Flow ^b (k-ft ³ /s)	Load (MW)	Head (ft)			Plant sigma ^c (σ)	Estim. eff. (%)
27 Jun	73.7	15.0	62.4	14.7	67	58.7	0.98	92.5	u*	65
28 Jun	74.7	14.2	60.5	14.2	67	60.1	0.94	92.5	u	65
29 Jun	74.8	14.3	60.1	13.9	67	60.5	0.94	92.5	u	66
30 Jun	74.7	12.2	57.8	13.9	67	62.5	0.87	92.5	u	66
1 Jul	74.4	10.7	56.6	13.4	67	63.7	0.83	92.5	u	66
2 Jul	75.9	10.5	55.1	13.5	67	65.4	0.81	92.5	u	66
13 Jul	75.2	13.5	55.2	13.6	66	61.7	0.90	92.5	u	67
14 Jul	75.5	12.3	54.8	13.4	66	63.1	0.87	92.5	u	66
15 Jul	75.7	12.2	54.8	13.3	66	63.5	0.86	92.5	55.0	66
22 Jul	75.5	12.4	55.2	13.4	66	63.1	0.87	92.5	58.0	69
23 Jul	76.1	11.0	54.4	13.1	66	65.1	0.82	92.5	58.0	69
24 Jul	76.5	9.6	51.2	12.8	66	66.9	0.77	92.5	58.0	69

^a English units are used for selected parameters by convention.

^b Discharge calculated from Figure 8.1-1 of Bonneville Second Powerhouse model test report, Allis-Chalmers (1978).

$$\text{Plant Sigma } (\sigma) = \frac{(\text{Atmospheric pressure}) - (\text{Water Vapor pressure}) - (\text{CL runner elev} - \text{TW elev})}{\frac{\text{Head Pressure}}{(\text{pressure}) - (\text{pressure differential})}}$$

Where: CL = center line and TW = tailwater.

^d Data derived from Figure 8-02.1 of expected prototype performance of Bonneville Second Powerhouse (Allis-Chalmers 1978).

^e Bypass downwell regulated automatically and elevation unknown.

Appendix Table B4.--Flow data, operating conditions, and water temperatures at the times of release for the 20 release dates of the Bonneville Dam survival study, 1987.^a

Date	Second Powerhouse			Turbine 17				Est. effic. ^d (%)	River temp. (°F)
	Forebay elev. (ft)	Tailrace elev. (ft)	Flow (k'ft ³ /s)	Flow ^b (k'ft ³ /s)	Load (MW)	Head (ft)	Plant sigma ^c (σ)		
24 Jun	74.4	10.1	55.6	13.4	66	64.3	0.81	92.5	64
25 Jun	74.9	12.8	57.8	13.8	66	62.1	0.89	92.5	65
26 Jun	75.6	12.6	60.7	13.6	66	63.0	0.87	92.5	65
27 Jun	75.1	12.1	60.0	13.6	66	63.0	0.86	92.5	68
28 Jun	75.0	11.3	59.7	13.5	66	63.7	0.84	92.5	66
1 Jul	75.7	13.5	57.6	13.7	66	62.2	0.90	92.5	69
2 Jul	75.6	13.1	57.3	13.7	66	62.5	0.88	92.5	69
3 Jul	76.5	12.5	56.0	13.4	66	64.0	0.85	92.5	68
4 Jul	76.4	11.1	54.8	13.2	66	65.3	0.82	92.5	68
5 Jul	76.1	10.3	54.8	13.1	66	65.8	0.80	92.5	67
8 Jul	75.2	10.0	56.0	13.2	66	65.1	0.80	92.5	66
9 Jul	75.8	12.1	56.2	13.5	66	63.7	0.85	92.5	66
10 Jul	75.5	12.1	56.7	13.5	66	63.4	0.86	92.5	66
11 Jul	75.5	13.1	57.6	13.8	66	62.4	0.89	92.5	67
12 Jul	76.1	11.1	55.9	13.4	67	65.0	0.82	92.5	68
15 Jul	75.6	12.6	57.8	13.6	67	63.0	0.87	92.5	69
16 Jul	75.7	12.5	57.5	13.6	67	63.1	0.87	92.5	69
17 Jul	76.1	12.4	57.0	13.6	67	63.7	0.86	92.5	69
18 Jul	76.0	10.8	54.9	13.1	66	65.2	0.81	92.5	69
19 Jul	76.2	10.3	55.0	13.2	67	65.9	0.80	92.5	69

^a English units are used for selected parameters by convention.

^b Discharge calculated from Figure 8.1-1 of Bonneville Second Powerhouse model test report, Allis-Chalmers (1978).

^c
$$\text{Plant Sigma } (\sigma) = \frac{(\text{Atmospheric pressure}) - (\text{Water vapor pressure}) - (\text{CL runner elev} - \text{TW elev})}{\text{Head Pressure}}$$

Where: CL = center line and TW = tailwater.

^d Data derived from Figure 8-02.1 of expected prototype performance of Bonneville Second Powerhouse (Allis-Chalmers 1978).

Appendix Table B5.--Hour and sequence of releases used during the Bonneville Dam survival study, 1989.

Date	First release (0200 h)	Second release (0230 h)
22 June	Lower turbine & Bypass	Upper turbine & Frontroll & Spillway
23	Upper turbine & Frontroll	Lower turbine & Bypass & Spillway
24	Lower turbine & Frontroll	Upper turbine & Bypass & Spillway
6 July	Upper turbine & Bypass	Lower turbine & Frontroll & Spillway
7	Lower turbine & Bypass	Upper turbine & Frontroll & Spillway
8	Upper turbine & Frontroll	Lower turbine & Bypass & Spillway
13	Lower turbine & Frontroll	Upper turbine & Bypass & Spillway
14	Upper turbine & Bypass	Lower turbine & Frontroll & Spillway
15	Lower turbine & Bypass	Upper turbine & Frontroll & Spillway
20	Upper turbine & Frontroll	Lower turbine & Bypass & Spillway
21	Lower turbine & Frontroll	Upper turbine & Bypass & Spillway
22	Upper turbine & Bypass	Lower turbine & Frontroll & Spillway

APPENDIX C

Recovery of Juveniles: Sampling Effort and River Conditions,
Daily Recoveries (Raw Data and Data Standardized for Effort),
Diel Patterns, and Diet Composition

Appendix Table C1.--Daily purse seine and beach seine fishing effort, water temperatures, and Secchi disk turbidity measurements at Jones Beach during the Bonneville Dam survival study, 1989.

Date	Number of sets		Temp. °C	Secchi m	Date	Number of sets		Temp. °C	Secchi m
	Purse	Beach				Purse	Beach		
19 Jun	0	3	---	---	16 Jul	25	0	19	1.2
20 Jun	0	9	---	---	17 Jul	20	2	19	0.9
21 Jun	0	6	---	---	18 Jul	12	0	19	0.9
22 Jun	5	3	16	1.2	19 Jul	22	2	18	0.9
23 Jun	2	3	16	1.3	20 Jul	27	0	19	0.9
24 Jun	3	0	18	0.9	21 Jul	21	0	19	---
25 Jun	0	0	---	---	22 Jul	17	2	19	0.9
26 Jun ^b	7	2	17	---	23 Jul	14	0	19	1.1
27 Jun	6	0	18	0.9	24 Jul	21	0	19	1.1
28 Jun	11	0	18	0.9	25 Jul	12	3	20	1.1
29 Jun	18	0	16	0.9	26 Jul	18	0	19	1.1
30 Jun	12	4	18	0.8	27 Jul	23	0	19	1.1
1 Jul	14	0	18	0.9	28 Jul	23	1	19	1.1
2 Jul	18	1	17	0.9	29 Jul	24	0	19	0.9
3 Jul	19	0	18	0.9	30 Jul	31	0	19	1.2
4 Jul	5	0	17	1.1	31 Jul	9	2	19	1.4
5 Jul	11	0	16	0.9	1 Aug	9	0	19	1.2
6 Jul	6	6	18	0.9	2 Aug	4	3	19	1.4
7 Jul	8	0	17	0.9	3 Aug	4	0	19	1.5
8 Jul	12	0	18	1.1	4 Aug	3	0	20	1.4
9 Jul	6	5	19	0.9	5 Aug	3	0	19	1.4
10 Jul	8	0	19	0.9	6 Aug	1	2	20	1.2
11 Jul	26	0	19	0.9	7 Aug	2	1	19	1.2
12 Jul	14	0	18	1.1	8 Aug	1	0	21	1.2
13 Jul	26	2	18	0.9	9 Aug	1	0	20	---
14 Jul	17	0	19	1.1	10 Aug	1	0	19	1.1
15 Jul	29	0	19	0.9	11 Aug	1	0	19	1.4

^a -- = data not available.

^b First recovery of study fish.

Appendix Table C2.--Daily recoveries, recoveries standardized for effort, dates of median fish recovery, and movement rates to Jones Beach of marked groups, Bonneville Dam survival study, 1989.

Release date = 22 June (Julian 173)																		
Treatments ^a																		
Tag code (AG D1 D2) ^b																		
Date of recovery	UT			LT			BY			FR		SP		DS				
	23	26	56	23	26	59	23	26	61	23	26	62	23	28	01	23	28	02
	N ^c	A ^d		N	A		N	A		N	A		N	A	N	A		
26 Jun	7	18		7	18		9	23		5	13		8	21		2	5	
27	16	48		12	36		15	45		13	39		15	45		11	33	
28	25	41		19	31		29	47*		20	33		29	53		18	29	
29	18	18*		16	16*		27	27		20	20		19	19*		16	16*	
30 Jun	2 ⁽²⁾	3		7 ⁽¹⁾	11		4 ⁽³⁾	6		8 ⁽²⁾	12*		8 ⁽³⁾	12		3 ⁽¹⁾	5	
1 Jul	6	8		5	6		8	10		7	9		1 ⁽¹⁾	1		6	8	
2	9	9		9	9		13	13		10	10		12	12		4	4	
3	11	10		9	9		3	3		9	9		9	9		3	3	
4	7	25		5	18		1	4		3	11		5	18		2	7	
5 Jul	5	8		3	5		6	10		7	11		7	11		5	8	
6	2 ⁽¹⁾	6		1 ⁽¹⁾	3		1 ⁽¹⁾	3		4 ⁽¹⁾	12		3 ⁽²⁾	9		3 ⁽¹⁾	9	
7				2	5		1	2					3	7		1	2	
8	1	2		4	6					1	2		4	6		2	3	
9	3 ⁽¹⁾	9					1	3					2 ⁽¹⁾	6		1	3	
10 Jul	3	7		1	2		1	2		4	9		2	5				
11	1	1		1	1		3	2		2	1		8	6				
12	2	3		6	8		5	6		2	3		5	6		3	4	
13	9	6		5	3		3	2		8	6		5	3				
14	1	1		3	3		1	1		2	2		1	1				
15 Jul	7	4		3	2		8	5		9	6		11	7		3	2	
16	2	1		1	1		3	2		3	2		3	2				
17	1	1		1	1		1	1										
18				1	2		1	2								1	2	
19	2	2					1	1		5	4		2	2				
20 Jul	4	3		1	1		1	1		4	3		2	1		3	2	
21				1	1		1	1		1	1					1	1	
22							1	1								2	2	
23													1	1		1	1	
24																		
25 Jul																		
26																1	1	
27							1	1										
28																		
29																		
30 Jul													1	1		1	1	
31										1	2							
1 Aug																		
2																		
3																		
NA ^f	2			2			3			1			0			2		
Totals ^h	150	234		127	198		156	224		152	220		173	264		97	151	
Mvmt rate ⁱ	22.4			22.4			26.2			19.6			22.4			22.4		

Appendix Table C2.--Continued

Release date = 23 June (Julian 174)															
Treatments															
Tag code (AG D1 D2)															
Date of recovery	UT			LT		BY		FR		SP		DS			
	23	28	04	23	28	07	23	28	08	23	28	13	23	28	14
	N	A		N	A	N	A	N	A	N	A	N	N	A	
26 Jun								1	3			1	3		
27	12	36		2	6			9	27	9	27	13	39	14	42
28	18	29		20	33			25	41	17	28	27	44	22	36
29	19	19		22	22			18	18	27	27	21	21*	24	24
30 Jun	6	9		3	5			5 ⁽¹⁾	8*	8 ⁽¹⁾	12	6 ⁽²⁾	9	2	3
1 Jul	5	6		7	9			5	6	6	8	8	10	9	12*
2	14	14*		12	12*			8	8	5	5*	9	9	12	12
3	11	10		9	9			11	10	5	5	9	9	9	9
4	8	29		2	7			2	7	5	18	3	11	9	32
5 Jul	6	10		4	7			10	16	8	13	7	11	6	10
6	2	6		1 ⁽²⁾	3			2 ⁽¹⁾	6	1	3	3	9	8	24
7	2	5		1	2			2	5	2	5			2	5
8	4	6						1	2	5	8	2	3	1	2
9								(1)		2	6			3	9
10 Jul				2	5					5	11	1	2	3	7
11	3	2		4	3					4	3	5	3	2	1
12	2	3		1	1			1	1	5	6	2	3	2	3
13	10	7		2	1			6	4	11	8	3	2	2	1
14	4	4		1	1			3	3			2	2	2	2
15 Jul	13	8		20	12			11	7	8	5	12	7	10	6
16	3	2		8	6			4	3	7	5	3	2	4	3
17	1	1						1	1	2	2	2	2	1	1
18	4	6		1	2			2	3	1	2			2	3
19	2	2		2	2			1	1	2	2	2	2	4	3
20 Jul	6	4		3	2			5	3	4	3	2	1	4	3
21	2	2		2	2					1	1	1	1		
22								3	3			4	4		
23				1	1										
24														1	1
25 Jul	1	2													
26				1	1										
27															
28	1	1													
29															
30 Jul															
31	1	2													
1 Aug	1	2													
2															
3															
NA	3			2				1		2		3		6	
Totals	164	227		135	154			140	186	153	213	153	209	166	254
Mvmt rate	17.4			17.4				22.4		17.4		26.2		17.4	

Appendix Table C2.--Continued

Release date = 24 June (Julian 175)															
Treatments															
Tag code (AG D1 D2)															
Date of recovery	UT		LT		BY		FR		SP		DS				
	23	28	16	23	28	19	23	28	21	23	28	22	23	28	26
	N	A		N	A		N	A		N	A		N	A	
26 Jun															
27				1	3					2	6		1	3	
28	15	25		21	34	15	25	22	36	18	29		13	21	
29	31	31		28	28	23	23	20	20	26	26		24	24	
30 Jun	5 ⁽¹⁾	8		3 ⁽¹⁾	5	2 ⁽²⁾	3	3 ⁽²⁾	5	6 ⁽¹⁾	9		5 ⁽²⁾	8	
1 Jul	9	12		7	9	4	5	7	9	7	9*		5	6	
2	14	14		12	12*	12	12	13	13	16	16		11 ⁽¹⁾	11	
3	10	9*		5	5	7	7	7	7	10	9		5	5	
4	4	14		3	11	6	22*	4	14*	3	11		7	25*	
5 Jul	7	11		3	5	7	11	6	10	4	7		6	10	
6	3 ⁽¹⁾	9		3 ⁽³⁾	9	6 ⁽²⁾	18	4 ⁽²⁾	12	5 ⁽¹⁾	15		5 ⁽³⁾	15	
7	1	2		3	7	3	7	1	2	1	2		4	9	
8	1	2		3	5	3	5	1	2	4	6		1	2	
9	1	3		3	9	3	9			2	6			⁽¹⁾	
10 Jul	7	16		4	9	3	7	4	9	5	11		2	5	
11	6	4		4	3	7	5	2	1	1	1		3	2	
12	3	4		2	3	2	3	4	5	3	4		4	5	
13	9	6		7	5	3	2	8	6	10	7		8	6	
14	4	4				3	3	4	4	3	3		1	1	
15 Jul	14	9		13	8	8	5	14	9	10	6		7	4	
16	6	4		5	4	3	2	4	3	7	5		4	3	
17	2	2		2	2			3	3	3	3		2	2	
18	1	2		1	2	1	2			2	3				
19	2	2		2	2	5	4	5	4	2	2		1	1	
20 Jul	4	3		3	2	4	3	4	3	1	1		5	3	
21	1	1				1	1	4	3	3	3		2	2	
22				1	1	1	1	2	2				2	2	
23															
24															
25 Jul															
26						1	1	1	1						
27	1	1								1	1				
28															
29															
30 Jul				1	1										
31										1	2				
1 Aug															
2															
3															
NA	1			3		1		3		3			1		
Totals	164	198		147	184	138	186	154	183	161	203		136	175	
Mvmt rate	17.4			19.6		15.7		15.7		17.4			15.7		

Appendix Table C2.--Continued

Release date = 6 July (Julian 187)																		
Treatments																		
Tag code (AG D1 D2)																		
Date of recovery	UT			LT			BY			FR			SP			DS		
	23	28	28	23	28	31	23	28	32	23	28	35	23	28	37	23	28	38
	N	A		N	A		N	A		N	A		N	A		N	A	
7 Jul																		
8																		
9		1	3							1	3							
10 Jul	6	14		1	2		2	5		3	7				2	5		
11	8	6		5	3		6	4		7	5		6	4	11	8		
12	15	19		16	21		13	17		13	17		11	14	7	9		
13	44	30		35	24		36	25		53	37		49	34	36	25		
14	7	7		9	10		8	8		12	13		6	6	11	12		
15 Jul	80	50		92	57		81	50		73	45		93	58	81	50		
16	61	44*		54	39*		40	29*		45	32*		40	29*	45	32*		
17	9	8		10	9		9	8		15	14		13	12	16	14		
18	14	21		10	15		15	23		17	26		15	23	12	18		
19	27	22		22	18		19	16		30	25		23	19	20	16		
20 Jul	29	19		29	19		19	13		30	20		25	17	42	28		
21	9	8		6	5		10	9		6	5		10	9	13	11		
22	7	7		6	6		7	7		13	14		6	6	6	6		
23	1	1		1	1		2	3		2	3		2	3	4	5		
24	2	2		1	1		2	2		6	5		4	3	2	2		
25 Jul	2	3		1	2		1	2		1	2							
26	3	3		1	1		3	3		2	2		4	4				
27	5	4		2	2		6	5		4	3		4	3	1	1		
28	2	2		2	2		1	1		4	3		3	2	3	2		
29							1	1										
30 Jul				1	1		1	1					1	1				
31										1	2							
1 Aug															1	2		
2																		
3																		
NA	2			4			3			9			2		1			
Totals	334	273		308	238		285	232		347	283		317	247	314	246		
Mvmt rate	15.7			15.7			15.7			15.7			15.7		15.7			

Appendix Table C2.--Continued

Release date = 7 July (Julian 188)																		
Treatments																		
Tag code (AG D1 D2)																		
Date of recovery	UT			LT			BY			FR			SP			DS		
	23	28	41	23	28	42	23	28	44	23	28	47	23	28	49	23	28	50
	N	A		N	A		N	A		N	A		N	A		N	A	
8 Jul																		
9																		
10 Jul																		
11	5	3		8	6		3	2		4	3		4	3		2	1	
12	6	8		5	6		8	10		7	9		8	10		3	4	
13	32	22		32	22		23	16		31	21		39	27		25	17	
14	8	8		10	11		6	6		10	11		15	16		7	7	
15 Jul	79	49		78	48		83	52		90	56		84	52		93	58	
16	43	31*		59	42*		49	35		40	29*		57	41*		45	32	
17	11	10		12	11		12	11*		16	14		15	14		23	21*	
18	11	17		11	17		16	24		15	23		26	39		19	29	
19	26	21		20	16		32	26		34	28		28	23		31	25	
20 Jul	38	25		35	23		32	21		42	28		28	19		38	25	
21	12	10		17	15		19	16		21	18		17	15		12	10	
22	11	12		14	15		11	12		4	4		8	8		6	6	
23	3	4		3	4		1	1		1	1		2	3		1	1	
24	7	6		1	1		2	2		1	1		4	3		5	4	
25 Jul	1	2		(1)			3	5		1	2		1	2				
26	3	3		3	3		3	3		3	3		6	6		7	7	
27	2	2		3	2		4	3		1	1		4	3		9	7	
28	3	2		5	4		4	3		3	2		3	2		2	2	
29	1	1								2	2		2	2		1	1	
30 Jul	2	1								3	2		1	1				
31													1	2				
1 Aug	1	2																
2																		
3																		
NA	5			5			0			1			3			4		
Totals	310	239		322	246		311	248		330	258		356	291		333	257	
Mvmt rate	17.4			17.4			15.7			17.4			17.4			15.7		

Appendix Table C2.--Continued

<u>Release date = 8 July (Julian 189)</u>																		
Treatments																		
Tag code (AG D1 D2)																		
Date of recovery	UT			LT		BY		FR		SP		DS						
	23	28	52	23	28	55	23	28	56	23	28	59	23	28	61	23	28	62
	N	A		N	A		N	A		N	A		N	A		N	A	
9 Jul																		
10 Jul																		
11							1	1		3	2					2	1	
12	4	5		3	4		1	1					5	6		4	5	
13	20	14		23	16		25	17		34	24		31	21		25	17	
14	11	12		6	6		6	6		3	3		10	11		8	8	
15 Jul	80	50		64	40		74	46		73	45		59	37		72	45	
16	40	29		38	27		42	30		37	27		41	30		50	36	
17	14	13*		12	11		15	14		10	9*		13	12		9	8*	
18	8	12		20	30*		16	24*		11	17		15	23*		13	20	
19	31	25		27	22		38	31		31	25		33	27		19	16	
20 Jul	34	23		37	25		30	20		41	27		38	25		37	25	
21	14	12		15	13		19	16		12	10		16	14		24	21	
22	7	7		16	17		6	6		7	7		17	18		9	10	
23	2	3		2	3		4	5		2	3		5	6		2	3	
24	3	3		6	5		4	3		6	5		4	3		3	3	
25 Jul	1 ⁽¹⁾	2					2	3		1	2		2	3				
26	8	8		3	3		3	3		3	3		6	6		2	2	
27	6	5		3	2		7	5		6	5		9	7		11	9	
28	2	2		2	2		4	3		5	4		6	5		6	5	
29	5	4		2	2		1	1		1	1		3	2		1	1	
30 Jul	3	2		3	2		4	2		4	2		1	1		5	3	
31				2	4													
1 Aug							1	2										
2																		
3																		
NA	1			4			2			0			3			4		
Totals	295	231		288	234		305	239		290	221		317	257		306	238	
Mvmt rate	17.4			15.7			15.7			17.4			15.7			17.4		

Appendix Table C2.--Continued

Release date = 14 July (Julian 195)																		
Treatments																		
Tag code (AG D1 D2)																		
Date of recovery	UT			LT		BY		FR		SP		DS						
	23	31	13	23	31	14	23	31	16	23	31	19	23	31	21	23	31	22
	N	A		N	A		N	A		N	A		N	A		N	A	
15 Jul																		
16																		
17																1	1	
18		4	6		1	2		4	6		6	9		1	2		3	5
19		23	19		49	40		28	23		29	24		35	29		36	29
20 Jul		56	37		54	36		50	33		64	43		60	40		71	47
21		22	19		21	18		23	20		34	29		25	21		26	22
22		25	26*		32	34*		35	37*		25	26*		15	16		32	34*
23		10	13		8	10		8	10		6	8		7	9*		12	15
24		13	11		10	9		15	13		19	16		18	15		10	9
25 Jul		7	11		9	14		3 ⁽¹⁾	5		8 ⁽²⁾	12		8	12		8	12
26		15	15		9	9		14	14		17	17		18	18		16	16
27		21	16		31	24		20	16		24	19		25	20		33	26
28		10	8		16	13		20	16		23	18		25	20		17	13
29		10	8		13	10		10	8		9	7		15	11		21	16
30 Jul		11	6		14	8		11	6		14	8		19	11		14	8
31		2	4		2	4		4	8		1	2		3	6		2	4
1 Aug		2	4					3	6		2	4					2	4
2		1	5		2	9		1	5								1	5
3					1	5					1	5					1	5
NA		1			1			4			1			3			5	
Totals	233	208		273	245		254	226		285	247		277	230		311	271	
Mvmt rate	19.6			19.6			19.6			19.6			17.4			19.6		

Appendix Table C2.--Continued

Release date = 15 July (Julian 196)															
Treatments															
Tag code (AG D1 D2)															
Date of recovery	UT			LT		BY		FR		SP		DS			
	23	31	25	23	31	26	23	31	28	23	31	31	23	31	35
	N	A		N	A		N	A		N	A		N	A	
16 Jul															
17															
18															
19	8	7		24	20		10	8		20	16		16	13	13 11
20 Jul	50	33		62	41		34	23		50	33		61	41	64 43
21	35	30		33	28		26	22		16	14		32	27	30 26
22	27	29		39	41*		17	18		31	33		37	39	25 26
23	6	8		9	12		7	9		11	14		12	15	9 12
24	13	11*		11	9		13	11*		13	11*		11	9*	19 16
25 Jul	7 ⁽¹⁾	11		7	11		6	9		7 ⁽¹⁾	11		13 ⁽¹⁾	20	13 20*
26	22	22		21	21		15	15		19	19		20	20	17 17
27	20	16		18	14		20	16		44	34		34	27	43 34
28	27	21		27	21		20	16		26	20		22	17	32 25
29	9	7		12	9		12	9		10	8		16	12	12 9
30 Jul	13	8		19	11		16	9		14	8		17	10	11 6
31	3	6		2	4					1	2		4	8	5 10
1 Aug	2	4		1	2		1	2		2	4		3	6	3 6
2	1	5											2	9	3 14
3													1	5	
7							1						1		
NA	5			1			3			3			1		1
Totals	249	218		286	244		201	167		268	227		304	278	300 275
Mvmt rate	17.4			22.4			17.4			17.4			17.4		15.7

Appendix Table C2.--Continued

Release date = 22 July (Julian 203)												
Treatments												
Tag code (AG D1 D2)												
Date of recovery	UT		LT		BY		FR		SP		DS	
	23	31 61	23	31 62	23	32 01	23	32 02	23	32 04	23	32 07
	N	A	N	A	N	A	N	A	N	A	N	A
23 Jul												
24												
25 Jul					1	2	1	2				
26	23	23	11	11	22	22	11	11	27	27	31	31
27	45	35	51	40	66	52	43	34	75	59	49	38
28	68	53 ^c	76	59	68	53 ^c	64	50	86	67 ^c	69	54
29	34	26	29	22 ^d	21	16	36	27 ^e	45	34	45	34 ^f
30 Jul	46	27	66	38	44	26	52	30	80	46	63	37
31	5	10	18	36	11	22	9	18	10	20	13	26
1 Aug	9	18	8	16	9	18	9	18	16	32	10	20
2	2	9	5	23	2	9	6	27	2	9	3	14
3	1	5	2	9							1	5
4					1				1			
5 Aug	1											
6	2											1
7					1		2					
8			1									1
NA	3		5		5		4		5		7	
Totals	239	206	272	254	251	220	237	217	347	294	293	259
Mvmt rate	26.2		22.4		26.2		22.4		26.2		22.4	
Grand totals												
	UT		LT		BY		FR		SP		DS	
Actual	2,950		2,943		2,836		3,051		3,375		3,230	
Standardized	2,760		2,712		2,643		2,836		3,134		2,998	

^a Treatment codes are: UT = Upper Turbine, LT = Lower Turbine, BY = Bypass, FR = Frontroll, SP = Spillway, DS = Downstream (mid-river).

^b AG D1 D2 = Agency, Data 1, Data 2. All tags were of the replicate format; replicate codes 1, 2, and 3 were used with each tag number.

^c N = Actual daily purse seine catch of the particular mark group.

^d A = Adjusted daily purse seine catch obtained by standardizing the daily purse seine effort to 18 sets from 26 June - 3 August (Julian 177-215). Few study fish were captured subsequent to 3 August, and purse seine effort was much reduced during the final week of sampling.

^e Day that the median fish was captured (adjusted effort).

^f () = Beach seine recoveries. Not used in data standardization.

^g Date of recovery unavailable. Not used in data standardization.

^h Actual totals include all purse seine and beach seine data; adjusted totals include only purse seine standardized data.

ⁱ Mvmt Rate = Movement rate (km/day) = distance traveled (Rkm 232, control release site minus Rkm 75, Jones Beach sampling site) ÷ travel time (in days, from release date to date of median fish recovery at Jones Beach).

Appendix Table C3.--Diel distribution of treatment groups at Jones Beach,
Bonneville Dam survival study, 1989.

	Treatments											
	Upper turbine		Lower turbine		Bypass system		Front-roll		Spillway		Down-stream	
	No.	%	No.	%	No.	%	No.	%	No.	%	No.	%
<u>DIEL SAMPLING 20-21 JULY</u>												
Fish released 6-8 July												
Daylight	52	91.2	36	90.0	36	97.3	46	86.8	42	97.7	53	93.0
Darkness	5	8.8	4	10.0	1	2.7	7	13.2	1	2.3	4	7.0
Fish released 13-15 July												
Daylight	66	97.1	79	92.9	68	94.4	101	94.4	65	94.2	92	94.8
Darkness	2	2.9	6	7.1	4	5.6	6	5.6	4	5.8	5	5.2
<u>DIEL SAMPLING 29-30 JULY</u>												
Fish released 13-15 July												
Daylight	13	86.7	25	92.6	19	89.2	15	93.8	18	85.7	17	77.3
Darkness	2	13.3	2	7.4	5	20.8	1	6.2	3	14.3	5	22.7
Fish released 20-22 July												
Daylight	69	100.0	60	96.8	54	96.4	63	96.9	94	100.0	80	95.2
Darkness	0	0.0	2	3.2	2	3.6	2	3.1	0	0.0	4	4.8
<u>TOTALS</u>												
Daylight	200	95.7	200	93.5	177	93.7	225	93.4	219	96.5	242	93.1
Darkness	9	4.3	14	6.5	12	6.3	16	6.6	8	3.5	18	6.9

Appendix Table C4.--Diet (prey counts) of study fish recovered at Jones Beach, Bonneville Dam survival study, 1989.

Sample date: Sample time (24 hr clock):	1989					1980 ^a									
	12 July	20 July	21 July	29 July	30 July	14 July	28 July								
	0951	1041	2056	2239	0210	0337	0453	1425	2049	2242	0014	0138	0541	0600 to 1400	
Stomachs pooled:	6	12	12	2	9	6	12	18	18	1	2	7	14	25	18
Average Counts of Prey Item ^b															
Insecta															
Diptera	1	3	1	14	1	1	8	8	2	<1	<1	<1	7	8	9
Unidentifiable	1	3	1	4	<1		2	1	5	<1	<1	1	1	4	6
Other					<1		<1	1	1				<1	1	1
Total	2	6	2	18	1	<1	10	10	7	1	1	1	8	13	16
Crustacea															
Cladocera	195	500	561	79			334	442					10	45	30
Amphipoda	<1	1	<1	<1	<1	1	<1	1	1	<1	<1	<1	<1	1	2
Other	1	2	2	<1			<1	<1					<1	2	4
Total	196	503	563	80	<1	1	<1	334	444	<1	<1	<1	11	48	36
Other items			1		<1		1	<1		1				<1	<1
Total content weight (g):	0.039	0.091	0.079	0.017	0.021	0.021	0.008	0.084	0.073	0.048	0.040	0.020	0.093	0.036	0.038

^a Data from Kirn et al. 1986.

^b Average count = (number of prey items in pooled stomachs) ÷ (number of stomachs)

24 June 1989 Release

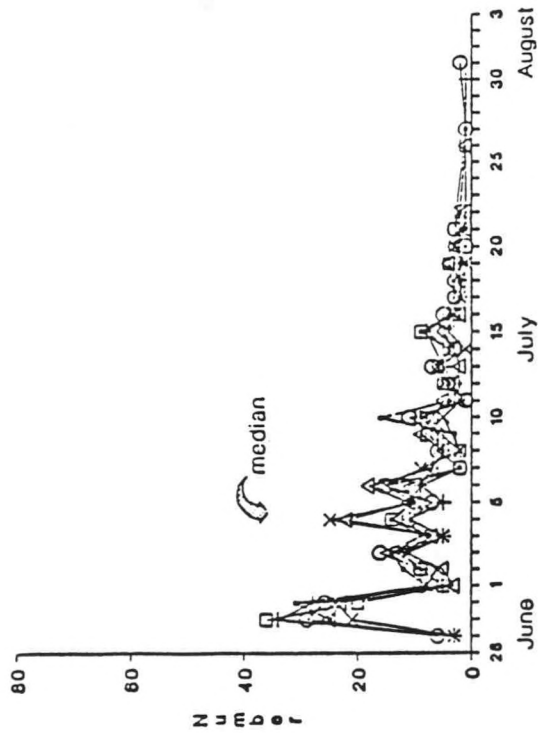

22 June 1989 Release

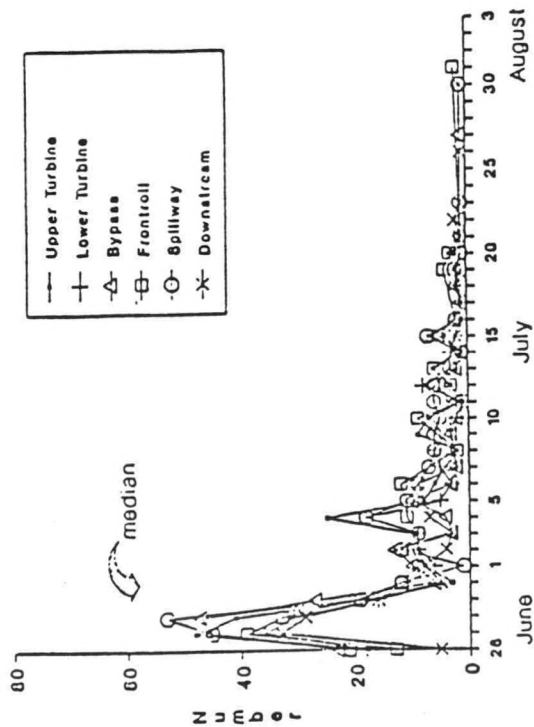

8 July 1989 Release

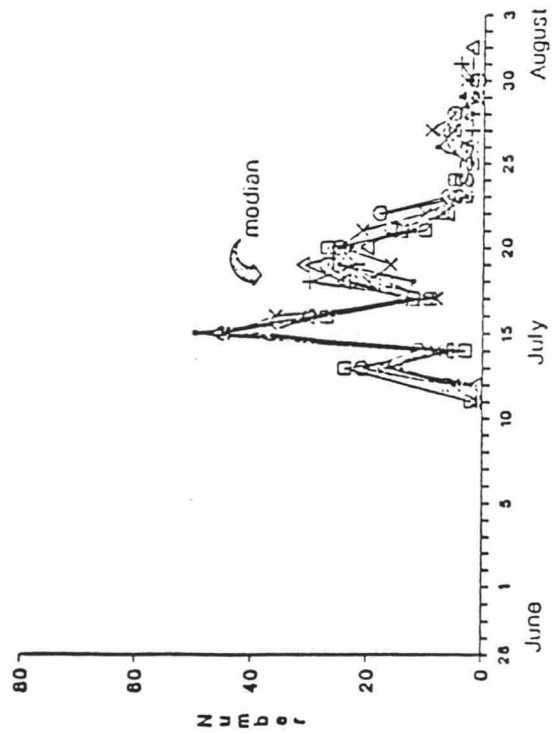

6 July 1989 Release

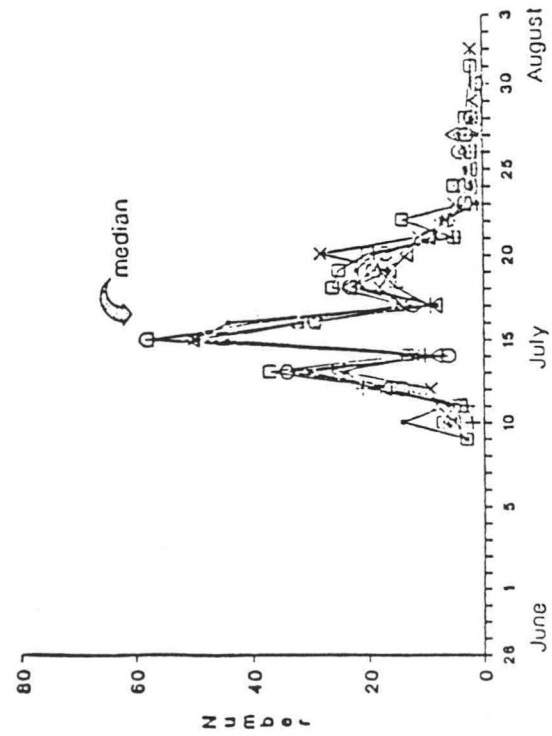

Appendix Figure C1.--Daily recoveries of test fish at Jones Beach (standardized for effort) from releases made at Bonneville Dam on 22 June, 24 June, 6 July, and 8 July 1989. Data for the middle day of each of the release series are provided in the report.

13 July 1989 Release

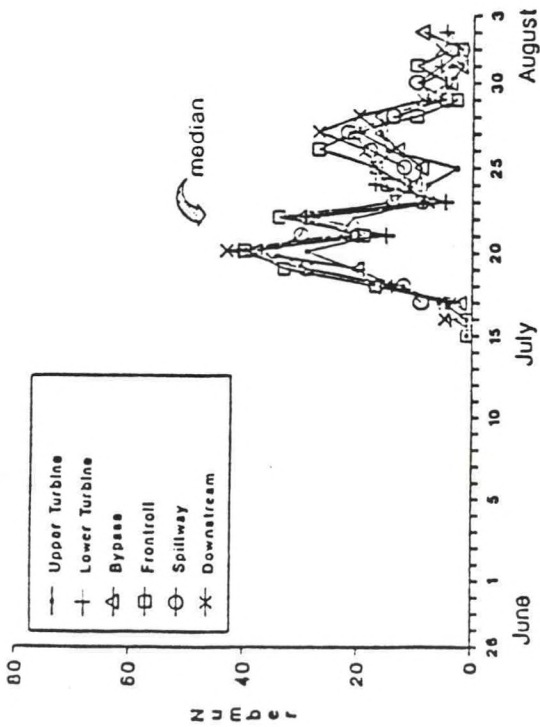

15 July 1989 Release

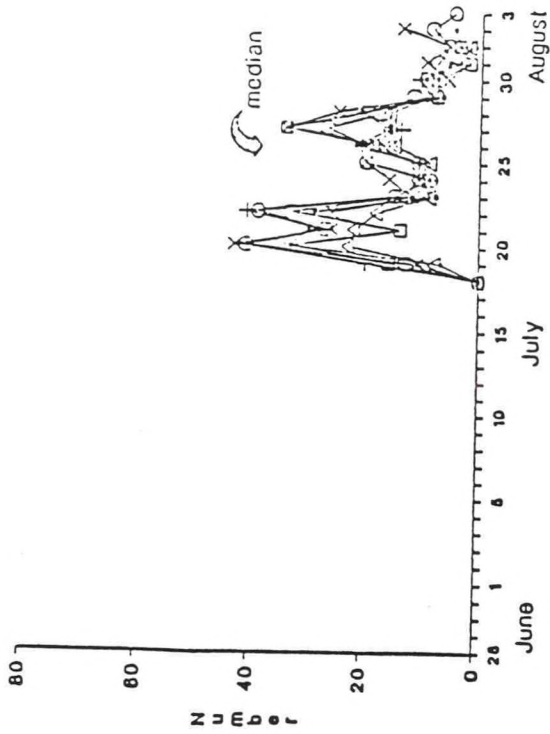

20 July 1989 Release

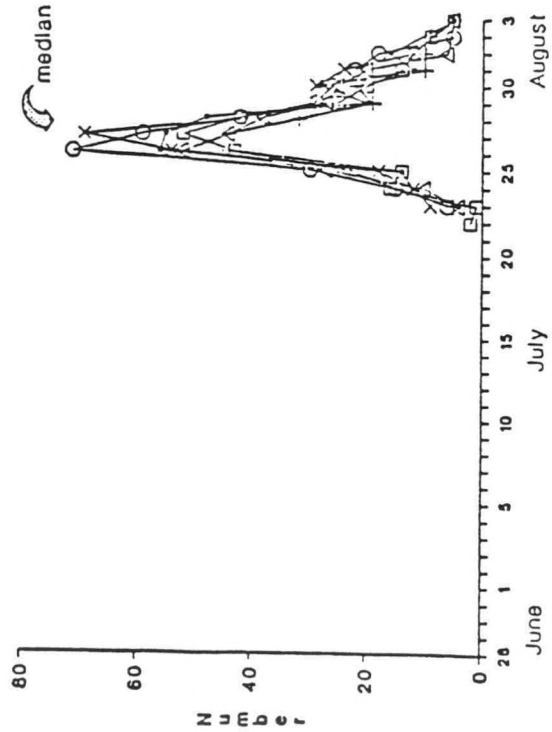

22 July 1989 Release

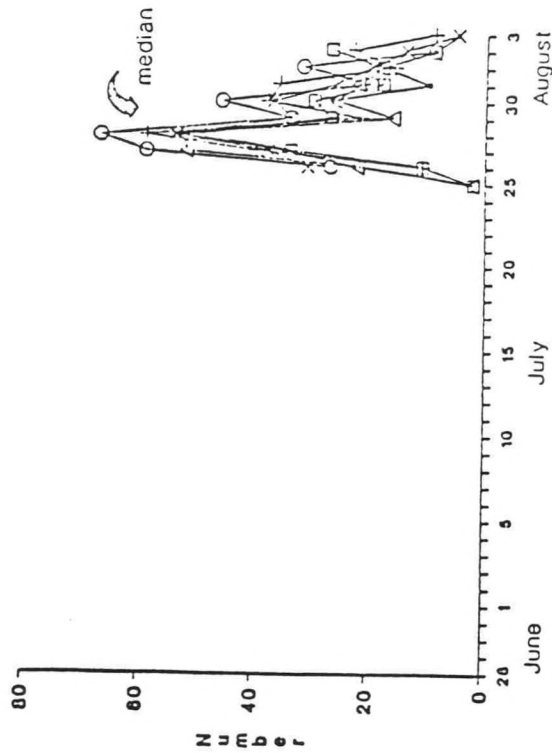

Appendix Figure C2.--Daily recoveries of test fish at Jones Beach (standardized for effort) from releases made at Bonneville Dam on 13, 15, 20, and 22 July 1989. Data for the middle day of each of the release series are provided in the report.

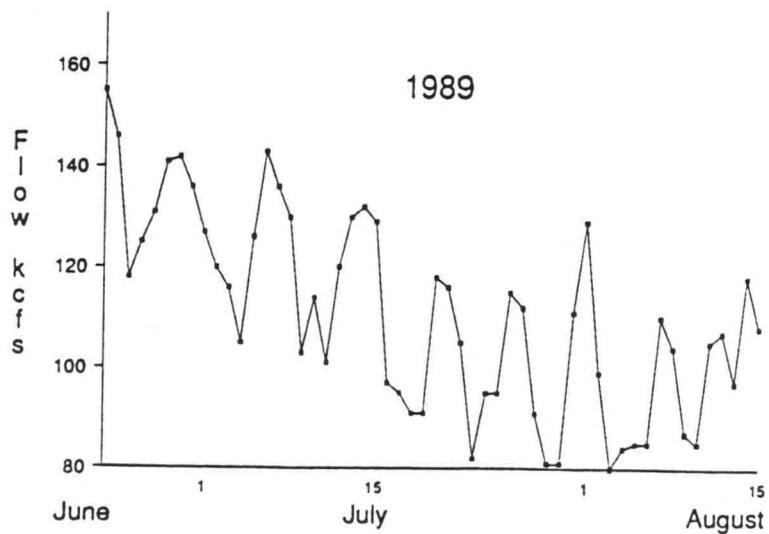
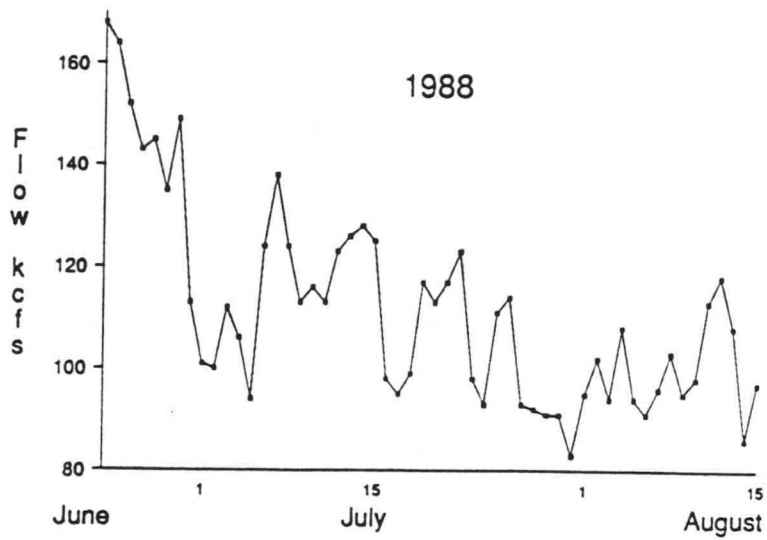
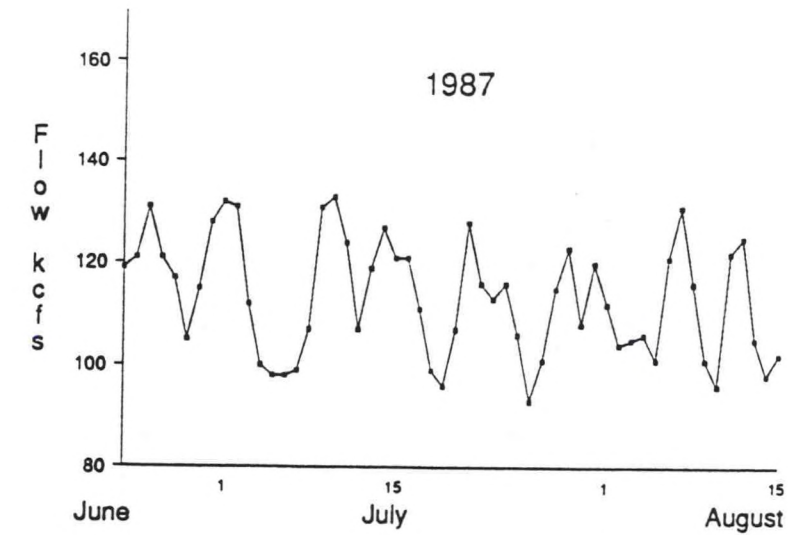

Appendix Figure C3.--Daily mean river flow during the estuarine sampling periods of 1987, 1988, and 1989; measured at Bonneville Dam by the U.S. Army Corps of Engineers, Portland, Oregon.

APPENDIX D

Coded-Wire-Tag Processing

CODED-WIRE-TAG PROCESSING

In 1989 at Jones Beach, brands were used to identify study fish for the purposes of determining percentage recovered, to obtain biological samples, to adjust sampling for maximum catches, and to attain length measurements for comparisons between treatment groups for each of the four release series. All branded study fish were sacrificed to obtain coded-wire tags (CWT) which had been implanted in the heads of fish prior to release; over 19,000 fish were recovered and sacrificed. The CWTs identified treatment groups and days of release. Procedures used in tag processing, decoding, and verification are described below.

Collection and Storage

Onboard each vessel, the heads of deeply anesthetized, branded fish were removed with scissors and placed in 1-gallon plastic jars. Heads from beach seine-caught fish were kept separate from purse seine-caught fish. Each jar had a capacity for over 1,000 heads, and generally a single jar was sufficient to store the entire day's catch. Each jar was labeled with sample location, date, vessel, and total number of heads. At the end of the day, jars were brought to shore and a 40% solution of potassium hydroxide (KOH) was added in sufficient quantity to cover the heads. In about 48 hours, the strong alkaline solution dissolved the head tissue, freeing the implanted CWTs. Storage of CWTs for up to 60 days in the KOH solution had no adverse effects on the stainless steel tags.

Preparation of CWTs for Decoding

To retrieve the CWTs from the KOH/tissue slurry, a magnetic stirring rod measuring 50-mm long by 6-mm diameter, was dropped into the jar and the jar placed on an electric stirrer. After about 1 minute of stirring, the stirring rod and attached CWTs were removed from the KOH/tissue slurry using rubber-coated tongs and placed in a sonic agitator bath containing vinegar. Sonic agitation, commonly used to clean jewelry, greatly facilitated tag decoding by cleaning residue from the surface of the tags and neutralizing the KOH. After about 1 minute in the agitator bath, the stirring rod, CWTs, and a label containing recapture information were sealed in a 500-ml screw-cap bottle.

CWT Decoding

A computerized method was developed for processing tags and data. Some important features of the tag decoding procedure included 1) direct computer entry of tag data avoiding hand-written data and subsequent keypunching/verification procedures, 2) generation of a computer data file for rapid access to tag information, 3) assignment of a unique identification code for each tag to assist in editing and verification, and 4) production of a paper form onto which individual tags could be secured for permanent storage. The procedure also provided a framework to help train tag readers and evaluate their proficiency.

Batch processing

Tags were processed in batches of 25. Working over a clean surface, tags were picked from the stirring rod and placed into

25 numbered depressions on a tag-holding bar. Once removed from the magnetized stirring rods, magnetic tweezers with an on/off switch were used to load the tag-holding bar. The tag-holding bar was made of aluminum, measured 50 by 350 mm, and was painted white to provide a contrasting background for the tags. A drill was used to make 5-mm deep depressions in the bar. A piece of adhesive tape 25-mm wide by 350-mm long (page length) was placed (glue side up) adjacent to the tag-holding bar; after decoding and verification, each tag was placed in order on the tape.

Tags were decoded using a 45X binocular dissecting microscope. A magnetic tag-reading pencil (available from Northwest Marine Technology, Inc., Shaw Island, Washington)¹ was used to remove tags from the depressions in the bar. The pencil, with the tag centered length-wise on the magnet, was placed on a jig on the microscope stage for decoding; the tag was then decoded.

Initial tag decoding

After the tag holding bar, tape, microscope light, and computer were positioned, the tag reader started the computer program by entering his or her name and recapture information for the batch of tags to be read. The program created a unique identification number for each tag--a combination of a single letter tag-reader identification code and a sequence number. The master code on the tag was located, and the tag decoded by proceeding, in order, from

¹ References to trade names do not imply endorsement by the National Marine Fisheries Service, NOAA.

data 1 code, agency code, data 2 code, and replicate code². After the respective codes were entered into the computer, the program checked the entry against a list of all Bonneville Dam survival study tag codes. If the entry was not on the list, the computer issued a warning to check the entry for typing errors. After the tag data were successfully entered, the reader returned the tag to the depression in the tag-holding bar and proceeded to the next tag. After all tags in the batch were decoded, the program repositioned itself in the data-base to the record for the first tag on the bar, and the reader proceeded with tag verification.

Verification

Verification of decodings was similar to the initial decodings. When the first and second decodings matched (including replicate code), the reader was instructed to place the tag on the tape adjacent to its depression in the tag-holding bar and proceed to the next tag. If the second decoding did not match, a third decoding was required (while the tag was still on the reading pencil). This decode/verify procedure continued until a match was obtained or until four decodings had been attempted. If no match was obtained in four attempts, the word 'VERIFY' was placed in the data file and the reader was allowed to continue. When the entire batch was verified, the computer generated a paper form listing the tag data, recapture information, and tag identification codes. The tape with attached tags was secured lengthwise along the right margin of the

² Details of tag decoding are available from Northwest Marine Technology, Inc., Shaw Island, Washington 98286.

computer form, and a new batch of tags was processed or the program terminated.

Tag Reader Efficiency and Error

The majority of tags were decoded by four persons of proven proficiency (selected after about 8 hours of training and evaluation). Generally, a proficient reader had very few third reads listed on the paper form, and often the errors involved the replicate code and would not have affected treatment assignment. Generally, matches by poor readers did not involve the initial read, probably due to the time lapse between initial read and verification; instead, a match was obtained from third and fourth attempts while the tag remained positioned under the microscope. Readers with a high percentage of third and fourth attempts were not utilized. Proficient tag readers could process about 250 tags through the program in an 8-hour day, excluding the time required to extract tags from the KOH solution.

All tags decoded a third or fourth time were independently verified. In addition, a subsample of about 400 tags with matching first and second decodings were independently verified to identify possible systematic errors. No systematic errors were discovered. Tags collected from fish that had been captured within 3 days of release were also independently verified. When errors were discovered, they were noted on the computer form and edited in the data-base by using the tag identification code.

Lost Tags

Because fish heads were pooled onboard the vessels, and not individually processed, tag loss could not be directly estimated. Tag loss was estimated by holding a sample of tagged fish at the hatchery. Fish with illegible brands and adipose-fin clips were also sacrificed; some of these fish were not study fish, which also limited our ability to estimate tag loss. Also, we could not detect double tagging of fish; however, we feel that it was a rare occurrence.

Tags were occasionally dropped during processing. Work areas were searched with a magnet at the end of each work shift and after each jar of tags was read. Tags discovered during this search were generally assigned to the most recently processed jar. When tags were found that could not be reasonably assigned to the most recently processed jar, the tag data were entered using a dummy date. This occurred when the tags were discovered on the floor of the tag-reading room, or when the date on the label of the most recently processed jar was earlier than the release date of the fish containing the lost tag (these tags were also independently verified). When tags were lost after the initial reading, the word 'LOST' was typed into the program for the matching read. When a tag matching the 'LOST' tag was discovered on the floor or the table, it was physically placed on the form, and the data file edited.

In 1989, a total of 19,741 branded fish were sacrificed, including over 700 requested by the Oregon Department of Fish and Wildlife to help evaluate their Tanner Creek release site. A total

of 19,185 tags were recovered, leaving a 2.8% discrepancy between the number of fish sacrificed and the number of tags recovered.

APPENDIX E

Statistical Analysis of Juvenile Catch Results

CONTENTS

I. 1989 Data.

- A. Differences in recoveries through time among treatment groups released on the same day; Chi-square.
- B. Differences in percentages of descaled fish among treatment; Analysis of Variance (ANOVA).
- C. Analysis of treatment effects; ANOVA.
 - 1. Estuarine recovery percentages.
 - 2. Purse seine recovery data standardized to a constant effort.
- D. Effects of release time (hour of release); first vs. second release; Student's t-test.
 - 1. Point source releases.
 - 2. Broadcast releases.

II. 1988 Data.

- A. Differences in recoveries through time among treatment groups released on the same day; Chi-square. Data presented in Dawley et al. 1989, Appendix D, Part I.
- B. Effects of release time (hour of release); first vs. second release; Student's t-test (revised data analysis).
 - 1. Point source releases.
 - 2. Broadcast releases.

III. 1987 Data.

A. Tests of the assumption that mixing of treatment groups occurred among the three beach seine recovery sites (Washington, Mid-River, Oregon). Analysis not previously presented.

1. Within release blocks; Chi-square.
2. Overall test (pooled data using Fisher's combined significance levels test).

B. Differences in recoveries through time among treatment groups released in the same date period; Chi-square. Analysis not previously presented.

IV. Multi-year Comparisons (pooled data).

- A. Estuarine recovery percentages, 1988 and 1989.
- B. Estuarine recovery percentages, 1987, 1988, and 1989.

Analysis of additional subsets of recovery data are available upon request.

I. 1989 Data.

A. Differences among treatment groups through time were examined to assess whether groups released the same day were mixed (i.e., traveling through the river at the same rate). Chi-square goodness of fit analysis (Sokal and Rohlf 1981) of observed purse seine recoveries (Appendix Table C2) was used for analysis. A non-significant result indicated that there was equal probability of capture at Jones Beach for each treatment group (i.e., that the groups were adequately mixed). For additional discussion of this procedure see Dawley et al. 1989, Appendix D).

H₀: There was homogeneity between recovery distributions of treatments in 1989.

Block	Date	Chi-sq.	df	P-value	Result
1	22 June	75.563	75	0.4601	non-significant
2	23 June	102.940	80	0.0431	significant
3	24 June	47.966	70	0.9796	non-significant
4	6 July	75.462	75	0.4633	non-significant
5	7 July	82.467	75	0.2596	non-significant
6	8 July	76.817	80	0.5801	non-significant
7	13 July	89.922	80	0.2100	non-significant
8	14 July	69.195	70	0.5047	non-significant
9	15 July	75.635	65	0.1726	non-significant
10	20 July	38.687	50	0.8774	non-significant
11	21 July	45.502	45	0.4511	non-significant
12	22 July	49.279	35	0.0553	non-significant

The 12 tests independently examined the same hypothesis, therefore their results can be combined to obtain an overall test (Fisher 1944). The overall test is:

Appendix E.--Continued.

Block	Date	P-value	-2ln(p)	df
1	22 June	0.4601	1.553	2
2	23 June	0.0431	6.289	2
3	24 June	0.9796	0.041	2
4	6 July	0.4633	1.539	2
5	7 July	0.2596	2.697	2
6	8 July	0.5801	1.089	2
7	13 July	0.2100	3.121	2
8	14 July	0.5047	1.368	2
9	15 July	0.1726	3.514	2
10	20 July	0.8774	0.262	2
11	21 July	0.4511	1.592	2
12	22 July	0.0553	5.790	2

Overall Chi-square = 28.855 24

P = 0.2257, non-significant

- B. Analysis of treatment descaling percentages of brand recoveries at Jones Beach using Analysis of Variance (ANOVA).

ANOVA Table

Source	Sum of squares	df	Mean square	F	Sig. level
Blocks	14.9356	3	4.9785		
Treatments	1.6011	5	0.3202	1.00	0.4512
Error	4.8065	15	0.3204		
Total	21.3432	23			

No multiple comparisons, since the F-test for treatments was not significant.

Treatment	Count	Mean
Bypass	4	1.0773
Downstream	4	1.5628
Frontroll	4	1.1693
Upper turbine	4	1.2054
Spillway	4	1.1068
Lower turbine	4	1.7686

Appendix E.--Continued.

C. Analysis of treatment effects using a randomized block ANOVA design where each day was considered a block (Sokal and Rohlf 1981).

1. Estuarine recovery percentages. Full data set using all release days, all release groups, purse seine and beach seine observed catch (Appendix Table C2).

H_0 : Mean recovery percentages for each treatment are equal.

ANOVA Table

Source	Sum of squares	df	Mean square	F	Sig. level
Blocks	3.2673	11	0.2970		
Treatments	0.2125	5	0.0425	7.07	<0.01
Error	0.3306	55	0.0060		
Total	3.81032	71			

Multiple Comparisons

Method: 95 Percent FPLSD Intervals

Treatment	Count	Mean	Homogeneous groups ^a
Bypass	12	0.8007	1
Lower turbine	12	0.8256	1
Upper turbine	12	0.8298	1
Frontroll	12	0.8637	1, 2
Downstream	12	0.9061	2, 3
Spillway	12	0.9604	3

Fisher's Protected Least Significance Difference
(FPLSD) = $t_{(\alpha=0.05)}(df=55) * \text{SQRT}(2 * \text{MSE}/r) = 0.0633$

^a Homogeneous groups are identified by a common number.

Appendix E.--Continued.

2. Purse seine recovery data standardized to a constant 18 set per day effort (Appendix Table C2).

ANOVA Table

Source	Sum of squares	df	Mean square	F	Sig. level
Blocks	0.3615	11	0.0329		
Treatments	0.1846	5	0.0369	5.20	0.0006
Error	0.3904	55	0.0071		
Total	0.9365	71			

Multiple Comparisons
Method: 95 Percent FPLSD Intervals

Treatment	Count	Mean	Homogeneous groups ^a
Bypass	12	0.7472	1
Lower turbine	12	0.7612	1
Upper turbine	12	0.7774	1,2
Frontroll	12	0.8043	1,2
Downstream	12	0.8405	2,3
Spillway	12	0.8950	3

$$\text{FPLSD} = t_{(\alpha=0.05) (df=55)} * \text{SQRT}(2 * \text{MSE}/r) = 0.0689$$

^a Homogeneous groups are identified by a common number.

Appendix E.--Continued.

D. Effect of release time (hour of release); first vs. second release.

1. Point source releases: bypass and frontroll.

First release		Second release		
Treatment	Recovery percent ^a	Treatment	Recovery percent ^a	Difference
Bypass	0.5991	Frontroll	0.5277	0.0714
Frontroll	0.5314	Bypass	0.5439	-0.0124
Frontroll	0.5351	Bypass	0.5377	-0.0026
Bypass	1.0208	Frontroll	1.1706	-0.1498
Bypass	1.1085	Frontroll	1.1131	-0.0046
Frontroll	0.9773	Bypass	1.0885	-0.1112
Frontroll	1.0181	Bypass	0.9141	0.1040
Bypass	0.9204	Frontroll	0.9745	-0.0540
Bypass	0.7408	Frontroll	0.9159	-0.1751
Frontroll	0.9501	Bypass	1.0363	-0.0862
Frontroll	0.8541	Bypass	0.9319	-0.0778
Bypass	0.9228	Frontroll	0.7968	0.1260

^a For this comparison, the differences in recovery percent due to release site were removed by adding the difference between the overall means of the two treatments to the bypass.

$$m_d = \text{Mean of the Differences} = -0.0310$$

$$s_d = \text{Standard Deviation of the Differences} = 0.0964$$

$$t = m_d / (s_d / \sqrt{n}) = -0.0310 / (0.0964 / \sqrt{12}) = -1.1147$$

$$P = 0.2887, \text{ non-significant}$$

Appendix E.--Continued.

2. Broadcast releases: upper turbine and lower turbine.

First release		Second release		
Treatment ^a	Recovery percent	Treatment	Recovery percent	Difference
Lower	0.4350	Upper	0.5152	-0.0802
Upper	0.5631	Lower	0.4622	0.1009
Lower	0.5033	Upper	0.5634	-0.0602
Upper	1.1315	Lower	1.0409	0.0906
Lower	1.0884	Upper	1.0493	0.0391
Upper	0.9984	Lower	0.9724	0.0260
Lower	0.8958	Upper	0.8355	0.0603
Upper	0.7887	Lower	0.9258	-0.1371
Lower	0.9692	Upper	0.8419	0.1272
Upper	1.0154	Lower	0.8568	0.1586
Lower	0.8941	Upper	0.8613	0.0328
Upper	0.7935	Lower	0.9133	-0.1198

^a For this comparison, the differences in recovery percent due to release site were removed by adding the difference between the overall means of the two treatments to the lower turbine. $m_y = 0.0199$; $s_d = 0.0978$; $t = 0.7037$; $P = 0.4962$, non-significant

Appendix E.--Continued.

II. 1988 Data.

A. Differences among recoveries through time among treatment groups released on the same day; Chi-square. Data presented in Dawley et al. 1989, Appendix D.

B. Effect of release time (hour of release); first vs. second release. Please note that this is a revised analysis from that presented in Dawley et al. 1989.

1. Point source releases: bypass and frontroll.

<u>First release</u>		<u>Second release</u>		
<u>Treatment*</u>	<u>Recovery percent</u>	<u>Treatment</u>	<u>Recovery percent</u>	<u>Difference</u>
Bypass	0.4773	Frontroll	0.4955	-0.0182
Frontroll	0.3829	Bypass	0.4549	-0.0719
Bypass	0.4819	Frontroll	0.4776	0.0044
Frontroll	0.4722	Bypass	0.5539	-0.0817
Frontroll	0.5251	Bypass	0.5443	-0.0192
Bypass	0.4053	Frontroll	0.4650	-0.0597
Frontroll	0.5593	Bypass	0.5245	0.0347
Frontroll	0.5794	Bypass	0.5716	0.0078
Bypass	0.6049	Frontroll	0.5689	0.0359
Bypass	0.4701	Frontroll	0.5805	-0.1105
Bypass	0.5212	Frontroll	0.5190	0.0022
Bypass	0.5037	Frontroll	0.4881	0.0156

* For this comparison, the differences in recovery percent due to release site were removed by adding the difference between the overall means of the two treatments to the bypass.

$$m_d = \text{Mean of the Differences} = -0.0217$$

$$s_d = \text{Standard Deviation of the Differences} = 0.0481$$

$$t = m_d / (s_d / \sqrt{n}) = -0.0217 / (0.0481 / \sqrt{12}) = -0.5628$$

$$P = 0.1464, \text{ non-significant}$$

Appendix E.--Continued.

2. Broadcast releases (1988): upper turbine and lower turbine.

First release		Second release		
Treatment ^a	Recovery percent	Treatment	Recovery percent	Difference
Lower	0.4811	Upper	0.4786	0.0025
Upper	0.4865	Lower	0.5609	-0.0744
Lower	0.4553	Upper	0.4752	-0.0199
Lower	0.4616	Upper	0.4869	-0.0253
Lower	0.4360	Upper	0.5166	-0.0806
Lower	0.4830	Upper	0.4451 ^b	0.0379
Upper	0.5499	Lower	0.5788	-0.0288
Lower	0.6552	Upper	0.5635	0.0916
Upper	0.5133	Lower	0.5146	-0.0013
Upper	0.5741	Lower	0.5848	-0.0107
Lower	0.5147	Upper	0.4503	0.0644
Upper	0.5197	Lower	0.3990	0.1207

^a For this comparison, the differences in recovery percent due to release site were removed by adding the difference between the overall means of the two treatments to the upper turbine. $m_d = 0.0063$; $s_d = 0.0619$; $t = 0.3553$; $P = 0.7297$ (non-significant).

^b This value was estimated using a Randomized Block ANOVA.

Appendix E.--Continued.

III. 1987 Data.

- A. Tests of the assumption that mixing of treatment groups occurred among the three beach seine recovery sites (Washington, Mid-River, Oregon). Analysis not previously presented.

Beach seine recovery data from Washington shoreline, Mid-River (Puget Island), and Oregon shoreline sites by treatment and by block, 1987.

		Washington	Mid-River	Oregon
Block 1 25-28 June	Upper turbine	72	4	178
	Lower turbine	83	8	210
	Bypass	71	13	166
	Downstream	66	13	148
Block 2 1-5 July	Upper turbine	158	39	339
	Lower turbine	129	20	306
	Bypass	178	25	403
	Downstream	160	21	374
Block 3 8-12 July	Upper turbine	157	50	554
	Lower turbine	166	46	539
	Bypass	141	44	472
	Downstream	140	40	459
Block 4 24 June & 15-19 July	Upper turbine	116	52	318
	Lower turbine	126	33	336
	Bypass	84	39	301
	Downstream	93	41	306
Block 5 Alternates 24 June- 19 July	Upper turbine	117	28	392
	Lower turbine	113	29	303
	Bypass	101	25	321
	Downstream	100	22	287

1. Within release blocks.

Block	Date	Chi-sq.	df	P-value	Result
1	25-28 June	8.824	6	0.1837	non-significant
2	1-5 July	9.647	6	0.1403	non-significant
3	8-12 July	0.752	6	0.9933	non-significant
4	24 June & 15-19 July	9.769	6	0.1347	non-significant
5	Alternates	3.402	6	0.7570	non-significant

Appendix E.--Continued.

2. Overall test (using Fisher's combined significance levels test) of the assumption that mixing of treatment groups occurred.

Among Recovery Sites (Washington, Mid-River, Oregon)
Within Release Blocks in 1987

Block	Date	P-value	-2ln(P)	df
1	25-28 June	0.1837	3.389	2
2	1-5 July	0.1403	3.928	2
3	8-12 July	0.9933	0.013	2
4	24 June & 15-19 July	0.1347	4.009	2
5	Alternates	0.7570	<u>0.557</u>	<u>2</u>
Overall Chi-square =			11.896	10
P = 0.2920, non-significant				

- B. Differences in recoveries through time among treatment groups released in the same date periods; Chi-square. (Data presented in Dawley et al. 1988, Appendix Table 3).

Within Release Blocks in 1987

Block	Date	Chi-sq.	df	P-value	Result
1	25-28 June	119.233	90	0.0213	significant
2	1-5 July	92.066	87	0.3346	non-significant
3	8-12 July	83.190	64	0.0538	non-significant*
4	24 June & 15-19 July	195.001	87	0.0000	significant
5	Alternates	126.121	102	0.0529	non-significant

* Lower turbine data were omitted from this analysis because brands representing that release were inadvertently released 15-19 July as well (Dawley et al. 1988).

Appendix E.--Continued.

IV. Multiyear Comparisons.

A. Estuarine recovery percentages in 1988 and 1989 (pooled).

ANOVA Table

Source	Sum of squares	df	Mean square	F	Sig. level
Blocks	6.2436	23	0.2715		
Treatments	0.1763	4	0.0441	10.23	<0.01
Error	0.3749	87	0.0043		
Total	6.8003	118			
Interaction					
Year X Treat	0.0091	4	0.0023	0.53	0.7162

One missing value has been excluded.

Multiple Comparisons
Method: 95 Percent FPLSD Intervals

Treatment	Count	Mean	Homogeneous groups*
Bypass	24	0.6191	1
Lower turbine	24	0.6680	2
Upper turbine	23	0.6732	2
Frontroll	24	0.6866	2
Downstream	24	0.7375	3

$$\text{FPLSD} = t_{(\alpha=0.05) (df=91)} * \text{SQRT}(2 * \text{MSE} / r) = 0.0373$$

* Homogeneous groups are identified by a common number.

Appendix E.--Continued.

B. Estuarine recovery percentages in 1987, 1988, and 1989 (pooled).

ANOVA Table

Source	Sum of squares	df	Mean square	F	Sig. level
Blocks	3.6110	28	0.1290		
Treatments	0.0496	2	0.0248	7.40	0.0015
Error	0.1709	51	0.0034		
Total	3.8482	85			
Interaction					
Year X Treat	0.0090	4	0.0023	0.67	0.6131

One missing value has been excluded.

Multiple Comparisons
Method: 95 Percent FPLSD Intervals

Treatment	Count	Mean	Homogeneous groups*
Bypass	29	0.6118	1
Lower turbine	29	0.6654	2
Upper turbine	28	0.6673	2

$$\text{FPLSD} = t_{(\alpha=0.05) (df=55)} * \text{SQRT}(2 * \text{MSE} / r) = 0.0300$$

* Homogeneous groups are identified by a common number.

APPENDIX F

Turbine Operations Associated with Concurrent Fish Guidance
Studies at the Second Powerhouse Bonneville Dam
Survival Study, 1987-89

Appendix Table F1.--Summary of Bonneville Dam Second Powerhouse operations associated with fish guiding efficiency (FGE) tests^a and Bonneville Dam Survival Study, 1987, 1988, and 1989.

1987

FGE tests^b: 14 - 24 July; 28 July - 1 August

Survival releases^c: 24-28 June; 1-5 July; 8-12 July; 15-19 July^d

1988

FGE tests: 6 July - 2 August

Survival releases: 27 June - 2 July; 13-15 July; 22-24 July

1989

FGE tests: 8 July; 10-14 July; 17-21 July; 24-28 July

Survival tests: 22-24 June; 6-8 July; 13-15 July; 20-22 July

^a Data provided by Michael Gessel, FGE project leader, NMFS, Pasco, Washington.

^b Second powerhouse operation for FGE tests: Units 11 and 18 started at 1600 h; Units 12 and 13 started at 2000 h; the four units were operated until termination of FGE tests about 2200 h.

^c Second powerhouse operation for survival study releases: Units 11, 16, 17, and 18 started at 2400 h and, operated until 0800 h.

^d Underlined values identify survival study release dates potentially affected by powerhouse operation for FGE tests (i.e., periods with additional attraction flows for predators prior to the release of study fish).

APPENDIX G

Summary of Results of Juvenile Recoveries,
Bonneville Dam Survival Study, 1987 and 1988

Appendix Table G1.--Juvenile release and recovery data, Bonneville Dam
Survival Study, 1987.

Upper Turbine			Lower Turbine			Bypass			Downstream ^a		
Release ^b	Recovery		Release ^b	Recovery		Release ^b	Recovery		Release ^b	Recovery	
(No.)	(No.)	(%)	(No.)	(No.)	(%)	(No.)	(No.)	(%)	(No.)	(No.)	(%)
25-28 June release											
68,575	374	0.5454	66,581	402	0.6038	75,478	387	0.5127	70,622	347	0.4913
1-5 July release											
84,262	608	0.7216	76,471	506	0.6617	94,014	667	0.7095	92,838	610	0.6571
8-12 July release											
99,758	779	0.7809	105,448	767	0.7274	99,848	666	0.6670	98,793	656	0.6640
24 June & 15-19 July release											
110,320	510	0.4623	101,138	506	0.5003	108,290	441	0.4072	111,681	469	0.4199
Alternates---24 June - 19 July release											
79,191	547	0.6907	58,767	453	0.7708	78,579	460	0.5854	76,059	419	0.5509
Totals and means weighted by block (release period)											
442,066	2,818	0.6402	408,405	2,634	0.6528	456,209	2,621	0.5764	449,993	2,501	0.5567

Statistical analysis--common number indicates no difference among indicated treatments at $\alpha = 0.05$

1,2

1

2,3

3

^a Washington shore release 2.5 km downstream from the Bonneville Second Powerhouse.

^b Release data have been adjusted for brand retention.

Appendix Table G2.--Juvenile release and recovery data (brands), Bonneville Dam survival study, 1988.

Upper turbine			Lower turbine			Bypass			Frontroll			Downstream		
Release (No.)	Recovery (No.)	(%)	Release (No.)	Recovery (No.)	(%)	Release (No.)	Recovery (No.)	(%)	Release (No.)	Recovery (No.)	(%)	Release (No.)	Recovery (No.)	(%)
27 June release														
29,745	140	0.4707	29,929	144	0.4811	31,079	126	0.4054	29,666	147	0.4955	30,684	131	0.4270
28 June release														
30,720	147	0.4785	30,664	172	0.5609	30,291	116	0.3830	30,554	117	0.3829	30,716	138	0.4493
29 June release														
29,964	140	0.4672	29,868	136	0.4553	29,999	123	0.4100	30,363	145	0.4776	30,002	163	0.5433
30 June release														
30,067	144	0.4789	30,112	139	0.4616	30,085	145	0.4820	30,073	142	0.4722	30,068	138	0.4590
1 July release														
30,278	154	0.5086	29,817	130	0.4360	30,269	143	0.4724	30,470	160	0.5251	30,235	157	0.5193
2 July release														
0	0	0.00	30,432	147	0.4830	30,296	101	0.3334	30,110	140	0.4650	30,732	155	0.5044
13 July release														
30,260	164	0.5420	30,236	175	0.5788	29,097	145	0.4983	30,218	169	0.5593	29,934	171	0.5713
14 July release														
30,240	168	0.5516	30,069	197	0.6552	30,217	152	0.5030	30,202	175	0.5794	30,237	212	0.7011
15 July release														
30,676	155	0.5053	29,928	153	0.5112	29,957	144	0.4807	30,935	176	0.5689	30,897	210	0.6797
22 July release														
30,382	172	0.5661	30,096	176	0.5848	31,645	127	0.4013	29,112	169	0.5805	30,576	209	0.6835
23 July release														
30,068	133	0.4423	30,116	156	0.5180	30,046	135	0.4493	30,056	156	0.5190	30,052	185	0.6156
24 July release														
<u>30,096</u>	<u>155</u>	<u>0.5150</u>	<u>30,079</u>	<u>120</u>	<u>0.3989</u>	<u>30,106</u>	<u>130</u>	<u>0.4318</u>	<u>30,117</u>	<u>147</u>	<u>0.4881</u>	<u>30,106</u>	<u>203</u>	<u>0.6743</u>
Totals and means weighted by block (release day)														
332,497	1,671	0.5024	361,346	1,845	0.5104	363,087	1,587	0.4376	361,876	1,843	0.5095	364,239	2,072	0.5690
Statistical analysis--common number indicates no difference among indicated treatment means at $\alpha = 0.05$														
1			1			2			1			3		

APPENDIX H

Flow Patterns in Bonneville Dam Second Powerhouse
Tailrace Based on Model Studies Conducted
at the COE's Waterways Experiment Station

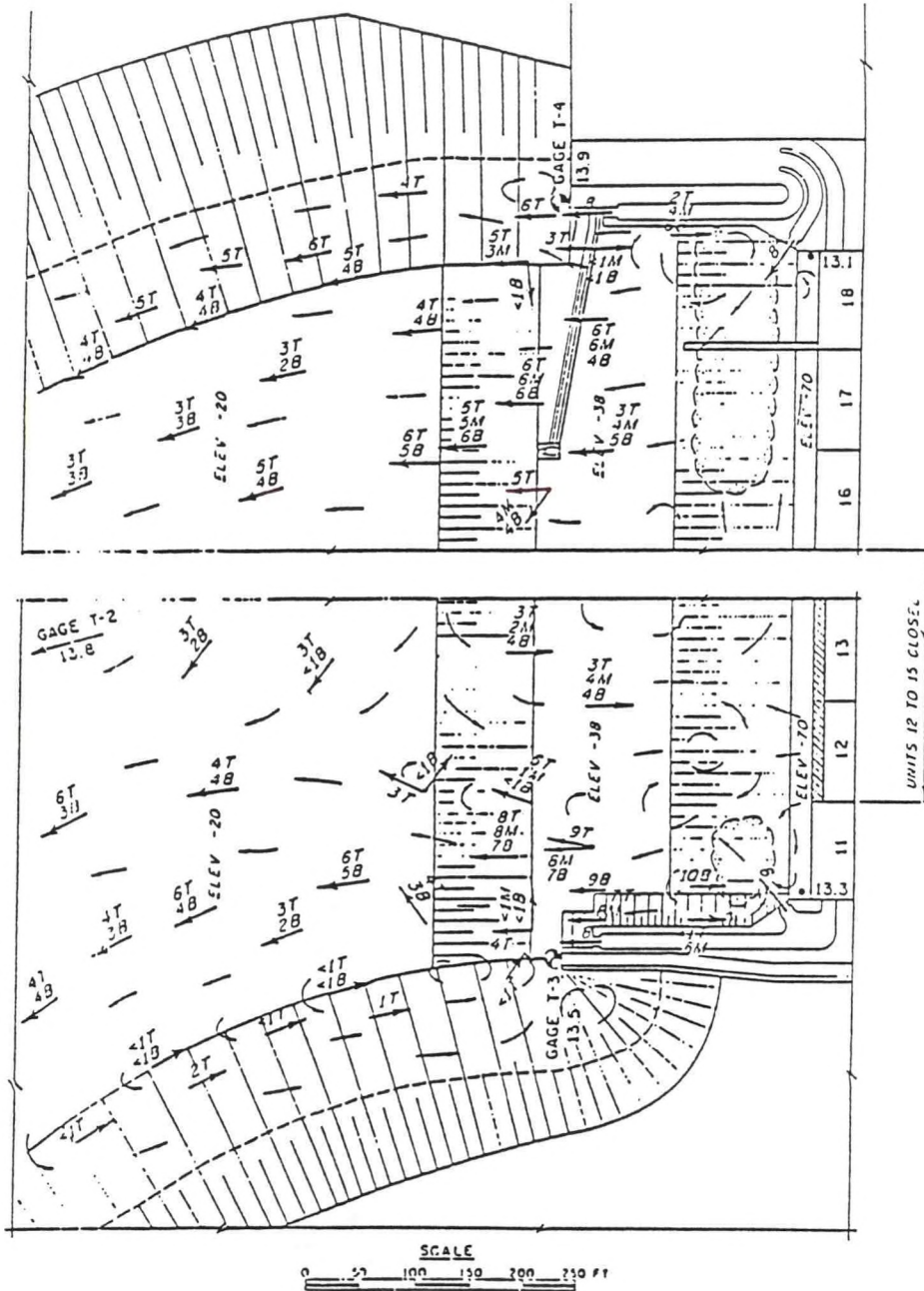

LEGEND

← VELOCITIES IN FPS
 T 5-FT DEPTH
 M MID-DEPTH
 B 5 FT ABOVE BOTTOM
 13.3 • WATER-SURFACE ELEVATION

FLOW DISTRIBUTION

SITE C-3 POWERHOUSE UNITS 11,16,17, AND 18	80000 CFS
SPILLWAY BAYS 1 AND 18	2400 CFS
SPILLWAY BAYS 2 TO 17	CLOSED
EXISTING POWERHOUSE UNITS 1,2,9, AND 10	40000 CFS
SITE C-3 POWERHOUSE FISH FACILITIES	4900 CFS

UNITS 11, 16, 17, AND 18 OPERATING

MODEL STUDY
 BONNEVILLE SECOND POWERHOUSE
 FLOW CONDITIONS
 FISHWAY ENTRANCES
 SITE C-3 POWERHOUSE
 PLAN C-6E TAILRACE
 RIVER DISCHARGE 127 300 CFS

D.H.L. FILE M137.4-57

Appendix Figure H2.--Current direction and velocities in the tailrace of Bonneville Dam Second Powerhouse with four turbines operating (similar to 1989 study conditions). Measurements from the COE model of Bonneville Dam.

APPENDIX I

Ancillary Evaluations of the Bypass Systems at Bonneville Dam

ANCILLARY EVALUATIONS OF THE BYPASS SYSTEMS
AT BONNEVILLE DAM

This appendix includes, in chronological sequence, results of ancillary testing conducted in 1988 and 1989 to further identify and evaluate causes of the reduced survival of subyearling fall chinook salmon passing Bonneville Dam Second Powerhouse via the fish bypass system (Dawley et al. 1988, 1989). Recovery percentages of bypass-released fish were about 11% lower than those of fish released into the turbine. These tests included measurements of water velocity in the tailrace near the bypass exit structure, visual inspection of the bypass conduit, and purse seine recovery of fish following bypass passage. Also included are results of a pilot study evaluating fish passage through the First Powerhouse.bypass system.

Water Velocity Measurements

On 23 March 1988, water velocities were measured at selected areas in the tailrace of the Second Powerhouse at Bonneville Dam and downstream. The objective of measuring velocities was to assess whether slack water areas were present which could serve as sanctuaries for predators near the outfall structure of the downstream migrant bypass system, the frontroll of Turbine Unit 17 discharge boil, or the area in mid-river adjacent to the Hamilton Island boat launch ramp.

Water velocity measurements were taken with flow conditions similar to those occurring during the June and July test periods. Turbine Units 11, 16, 17, and 18 were operated at maximum efficiency, each passing about 0.43 thousand m³/sec (15 k ft³/sec);

total river flow was about 3.7 thousand m^3/sec (130.7 k ft^3/sec) and tailwater height was about 3.9 m (12.7 ft). Measurements were taken at various sites in the tailrace at depths ranging from the surface to near the bottom (Appendix Figs. I1 and I2). Movement of the vessel from which measurements were being collected precluded obtaining great precision; however, the consistency of repeated measurements indicated a maximum variability of 0.2 m/sec (0.6 ft/sec) at any of the sites.

Velocities ranged from 1.1 to 1.5 m/sec (3 to 5 ft/sec). Visual observation of the surface currents downstream from the turbine booms of Units 17 and 18 and the bypass outlet structure (Appendix Fig. I2), indicated no apparent areas of low velocity; measurements at depth indicated the same. Thus, it was concluded that there were no large areas of low velocity near the bypass system outfall structure, except adjacent to the bottom.

The point at which fish would be exiting the bypass system is about 7.6 m (25 ft) off the bottom and about 8.5 m (28 ft) from the surface at the 4.6 m (15 ft) tailwater elevation expected during testing. The streamline shape of the outlet structure would likely eliminate the possibility of a low velocity sanctuary area for predators adjacent to that structure (Appendix Fig. I3). Visibility in the Columbia River during June, July, and August is generally less than 3 m (10 ft), and light penetration is less than 8.5 m (28 ft). Faler et al. (1988) noted that squawfish are generally not found in areas where water velocities are greater than 1 m/sec. However, visual observations of squawfish in the forebay of Bonneville dam, upstream of the First Powerhouse, show that

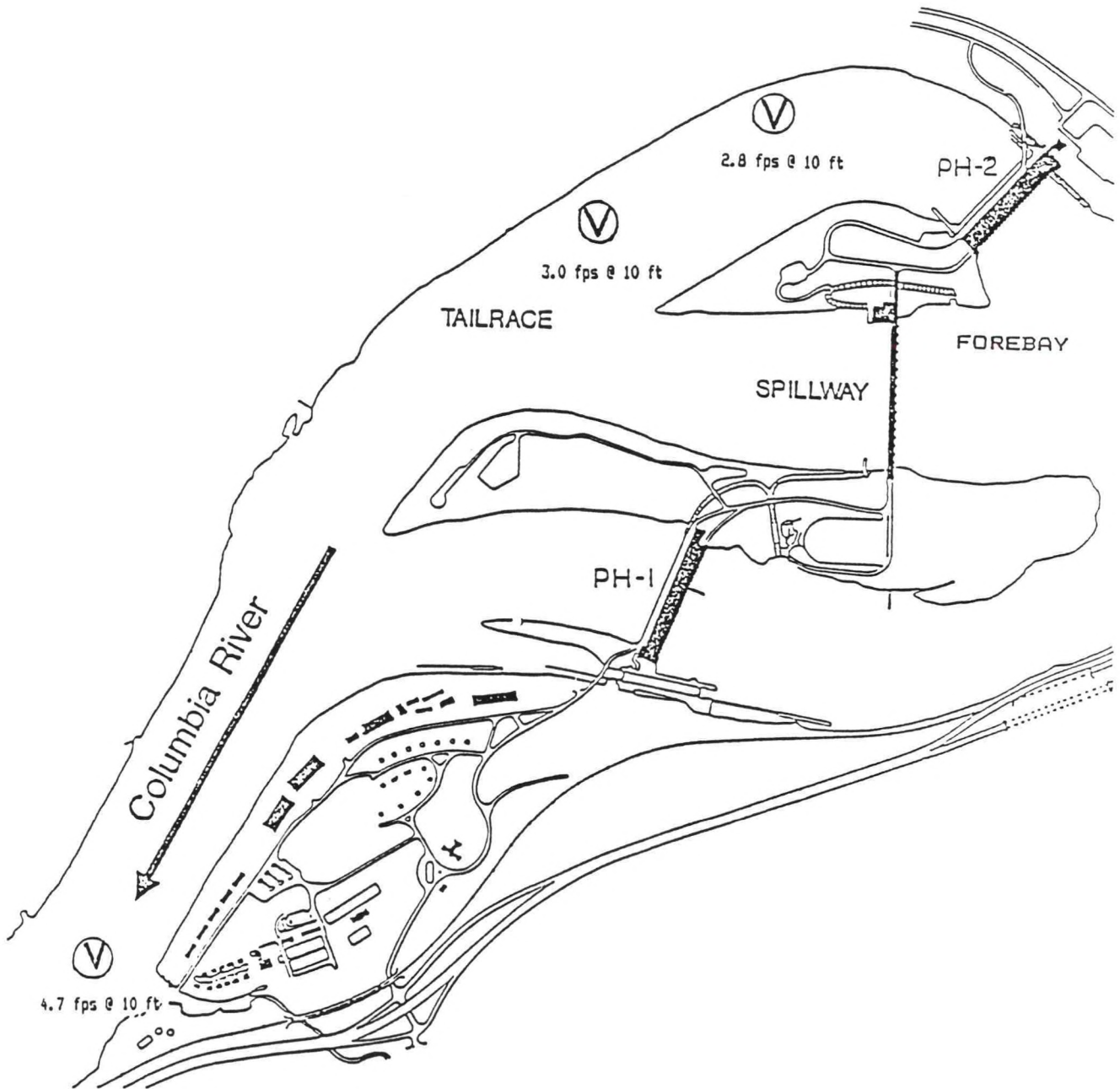

Appendix Figure 11.--Water velocity measurements downstream of the Bonneville Dam Second Powerhouse with four turbines operating 23 March 1988. Location of measurements indicated by V.

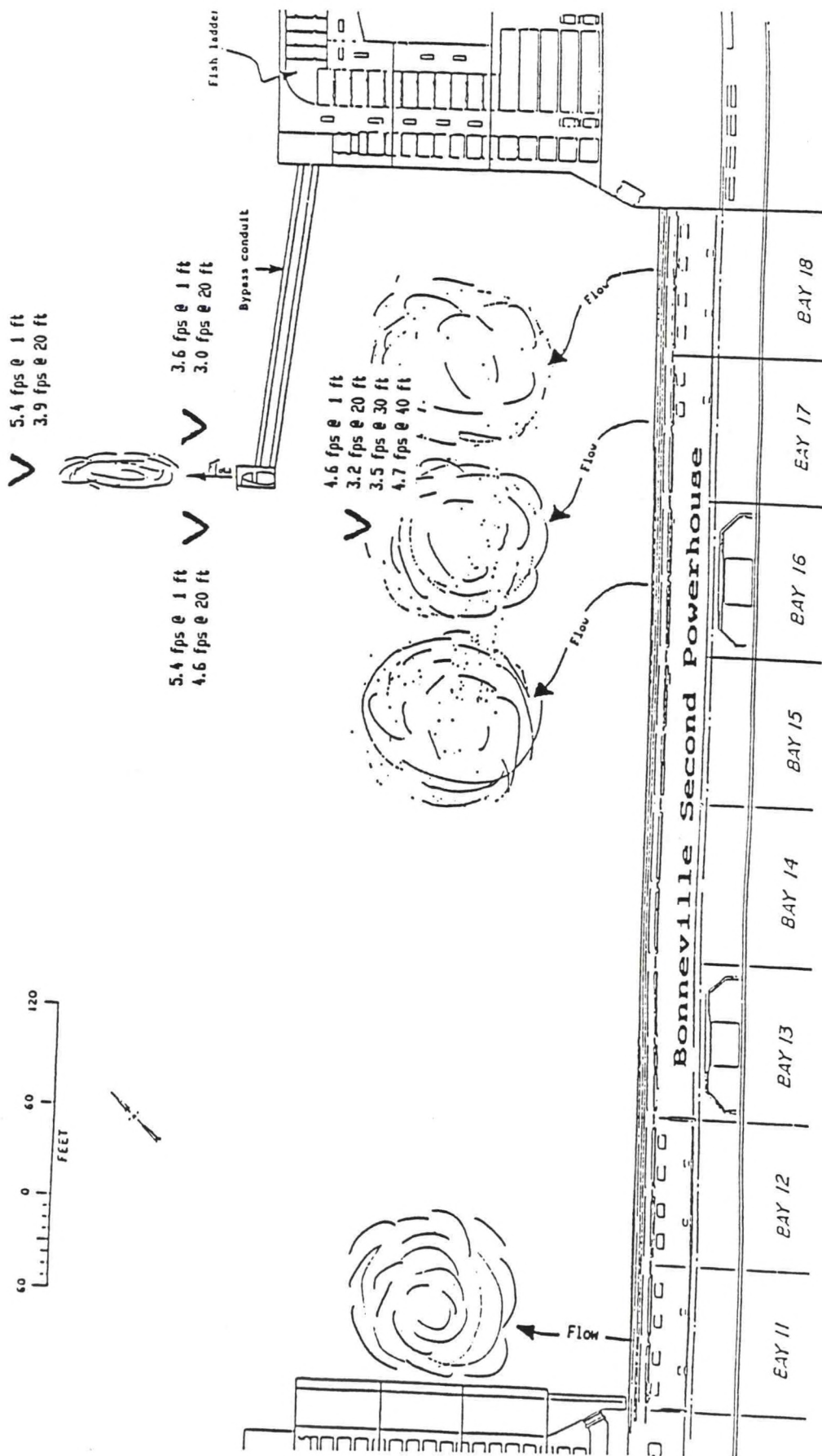

Appendix: Figure I2.--Velocity measurements near the Second Powerhouse bypass discharge plume and Turbine 17 discharge boiler, 23 March 1988 at tailwater elevation 12.7 ft. Location of measurements indicated by V.

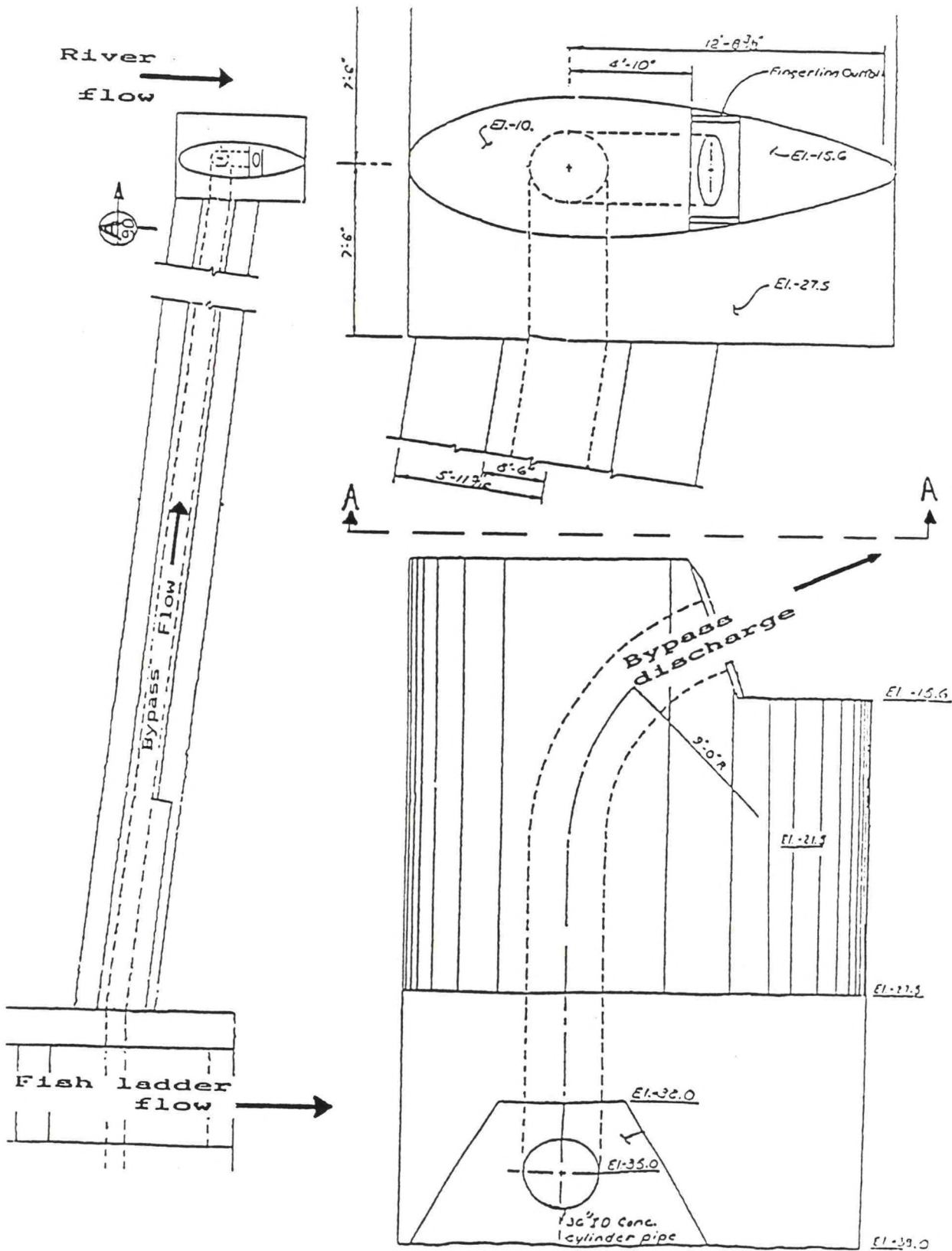

Appendix Figure I3.--Submerged bypass conduit and outlet structure of the fish bypass system at Bonneville Dam Second Powerhouse.

squawfish feed in areas where the velocities are greater than 1 m/sec and effectively prey on juvenile salmonids near the surface at night with available light.

Velocities about 1.1 m/sec (3 ft/sec) were found at two sites substantially downstream from the dam; one was half way to, and the other adjacent to, the downstream tip of Cascade Island about 30 m (100 ft) from the Washington shore (Appendix Fig. 11). Water depth in those areas is about 10 m (33 ft). Velocity at the downstream release site (mid-river adjacent to the Hamilton Island boat launch ramp) was greater than 1.4 m/sec (4.5 ft/sec).

Visual Examination of Conduit

Poor survival of the marked fish released into the bypass system in 1987, and the lack of any apparent predator sanctuary areas near the outflow structure, provided the impetus to visually examine the bypass system conduit from the downwell to the outlet structure for possible obstructions. However, further testing for possible problems with the bypass system was not attempted until after results from juvenile sampling in 1988 indicated similar low survival estimates for fish passing through the bypass system.

The Portland District U.S. Army Corps of Engineers contracted to visually examine the bypass conduit from the downwell, at elevation 17.7 m (58 ft), to the outlet structure using a remotely operated video camera. Flaws in the conduit which could possibly cause injury to passing fish were not found; however, the camera traveled only to the tailrace water level. Subsequently, another contract was let to visually examine the remaining section of the conduit

using SCUBA divers entering the outlet structure and swimming upstream to the tailwater surface elevation. Again, no structural flaws were observed that would likely impact fish passage; however, a small amount of concrete and metal debris was found and removed. The majority of the biologists and engineers examining the debris considered it unlikely that 10 to 20% of the fish passing through the conduit would be injured or killed as a result of that debris, but the possibility could not be completely ruled out.

Purse Seining, 31 August 1988

In August 1988, we first examined the possibility of purse seining adjacent to the outlet structure to sample fish immediately following passage through the bypass. Upriver bright juvenile fall chinook salmon were released through the bypass system of the Second Powerhouse at Bonneville Dam to assess percentages of injury and mortality. Fish weighing 20.9 g (22 fish/lb) were obtained at the Oregon Department of Fish and Wildlife's Bonneville Hatchery, tempered to Columbia River water during 3.5 to 5 hours, and then released into the bypass system. A group of dead fish of the same size as live fish, marked with an adipose fin clip and a brand, were released along with the test fish. A 200-m long by 10-m deep purse seine was used to recover the test fish immediately downstream of the bypass outlet structure. Fish recovered were examined for descaling, and any other external injury, and then measured for comparison to size at release.

Water temperature at Bonneville Hatchery was about 54°F and the Columbia River about 70°F. Turbines were not operating during the

preliminary seining assessment or during the test seining (1500-1900 h). No adult salmon were captured during seining.

The first group of fish, consisting of about 1,267 live and 1,500 dead fish, was released at 1650 h through a hose leading to the bypass gallery adjacent to Gatewell 17 B (the same site used in all earlier survival tests, 1987 and 1988). The second group of fish, approximately 1,336 live and 0 dead fish, was released at 1840 h through a hose placed 6 m upstream of the downwell in the middle of the bypass channel. Because of improper release procedures, the first group of fish was stressed prior to entering the bypass conduit and results of seining should be viewed with caution. However, observed injury and descaling rates were only 1.5 and 0.8%, respectively (589 recovered; Appendix Table I1). The second group of fish was released in relatively good condition. Direct mortality observed was 2.3%. Injury or descaling percentages were 1.2 and 1.2%, respectively, of 707 fish recovered; these values were similar to those of the first group.

Recovery percentage of dead fish was extremely low; 21 of the 1,500 released were captured. The low recovery was apparently a function of positioning of the net. We had assumed that a shorter net would purse closer to the outflow structure and possibly capture fish that were dropping out of the exit flow. However, this may not have been the case. In any event, the data collected in the two releases were inconsistent with results of the 1987 and 1988 survival study which suggested that mortality was in excess of 20%. However, it could not be ruled out that injured fish dropped from the water column upstream of the purse seine and thereby escaped

Appendix Table II.--Release and purse seine recovery of subyearling fall chinook salmon in the tailrace downstream of the Bonneville Dam Second Powerhouse bypass system, 1988 and 1989.

Treatment	Release No.	Recovered No.	%	Descaled		Cumulative Injured		Mortality			7 day mortality		
				No.	% ^a	No.	% ^a	No.	% ^a	Adj. % ^b	No.	% ^a	Adj. % ^b
31 August 1988, 70°F, 22/lb, 12' tailwater													
Killed	1,211	21	1.7	-	-	-	-	-	-	-	-	-	-
Alive	1,257	589	46.9	9	1.5	9	1.5	- ^c	-	- ^c	-	-	-
31 August 1988, 70°F, 22/lb, 12' tailwater													
Killed	0	0	-	-	-	-	-	-	-	-	-	-	-
Alive	1,336	707	52.9	1	1.2	9	1.2	4	2.3	- ^d	-	-	-
19 October 1988, 64°F, 14/lb, 10' tailwater													
Killed	250	15	6.0	-	-	-	-	-	-	-	-	-	-
Alive	750	24	3.2	1	4.2	1	4.2	1	4.2	2.2	-	-	-
19 October 1988, 64°F, 14/lb, 11' tailwater													
Killed	250	25	10.0	-	-	-	-	-	-	-	-	-	-
Alive	1,000	246	24.6	1	0.4	9	3.6	4	1.6	4.0	-	-	-
6 June 1989, 60°F, 73/lb, 19.2' tailwater ^e													
Killed	1,001	18	1.8	-	-	-	-	-	-	-	-	-	-
Alive	3,598	447	12.4	3	0.7	4	0.9	16	3.6 ^f	- ^g	16	3.6	-
Control	400	56	14.0	0	0.0	0	0.0	3	5.4 ^g	-	3	5.4	-

Summary

- 1) Maximum recoveries of live test fish were 46.9 and 52.9% of the release.
- 2) Maximum recoveries of killed fish were 6.0 and 10.0% of the release.
- 3) Maximum injury rates were 3.6 and 4.0% of the fish recovered.
- 4) Maximum mortality was 4.0% of the release population--adjusted for diminished recovery rates of dead fish.

-
- ^a Percent of the live test or control fish which were recovered (sample).
- ^b Percent of the release population as extrapolated from the recovery rate of the "killed" fish release group.
- ^c Fish were stressed prior to release and many moribund fish were captured.
- ^d Dead fish were not released.
- ^e Water temperature was 4°F lower than the lowest during the survival study. There was only a 6°F increase as fish were tempered to river water. High tailwater elevation caused the outlet structure to be about 9 ft below the effective fishing depth of the seine.
- ^f Measured after 18 hours of holding.
- ^g Control mortality was greater than test fish mortality, therefore there was no evidence of mortality due to treatment.

recapture. Therefore, additional testing was attempted with a smaller purse seine.

Purse Seining, 19 October 1988

A second series of releases and purse seining downstream of the bypass system outlet structure was conducted in an attempt to recover larger numbers of fish for a better assessment of the effects of passage.

Two groups of juvenile fall chinook salmon were released into the bypass system to assess physical damage caused by passage from the downstream migrant channel to the tailrace. Fall chinook salmon weighing 33 g (14 fish/lb) obtained from Bonneville Hatchery were trucked to the Second Powerhouse and tempered to Columbia River water for about 5 or 6 hours. Releases of about 750-1,000 live plus 250 marked dead fish were made at about 1345 and 1445 h. Marked fish were killed with concentrated anesthetic just prior to release, then placed into the bypass gallery as live fish were being released from the truck. Preliminary efforts to set a 100-m purse seine around the bypass outfall failed because of the rapid downstream movement. The standard-length net (200 m) set farther upstream than in previous work (August) was successful in capturing both live and dead test fish.

Few fish were recovered from the first release because of the high water velocity from the bypass outfall plume. Water current pushed the cork line under the surface for several minutes and we believe most fish passed over and out of the net. Thirty-nine test fish were recovered; 15 marked dead fish (6% of release) and 24 live

release test fish (about 3% of release). Of the 24 live-released test fish recovered, one each was descaled, injured, and dead (4.2% of the total).

Percentages recovered from the second release were higher than the first release, but less than from the August evaluation, due to the outfall plume holding the net under during pursing. Two hundred and seventy-one test fish were recovered; 25 marked dead fish (10% of release) and 246 live release test fish (about 25% of release). Effects of passage attributed to the bypass system were 0.4% descaling, 2.4% minor injury, 1.2% severe injury, and 1.6% morality. Additional dead fish were observed (1.2%), but these were thought to be dead prior to release. One dead non-test fish was also captured.

Incidental to the recovery of juvenile salmon was the capture of 55 adult northern squawfish in the first set and 2 in the second set. The difference between the two sets suggests that the squawfish may have traveled downstream with the first group of salmon. We examined the Jones Beach recovery data from the 12 replicate releases during the survival studies in 1988 and 1989 to determine whether there was correlation between survival rate and release time (i.e., if the lower turbine group was released at 0200 h and the upper turbine group at 0230 h, was there higher survival of the upper turbine group; or if the bypass group was released at 0200 h and frontroll group at 0230 h, was the poorer survival for the bypass group exaggerated). We concluded that there was no correlation between time of release and survival (Dawley et al. 1989).

In summary, based on the results of the 19 October 1988 testing, there appeared to be no evidence to support a theory of high injury of fish passing through the Second Powerhouse bypass system. Also, it seems improbable that huge numbers of northern squawfish impacted the bypass group substantially greater than the frontroll group because both groups appear to pass downstream at the same lateral location in the tailrace, based on dye tests.

Purse Seining, 6 June 1989

Additional purse seining was conducted in June 1989 at the Second Powerhouse in a further attempt to resolve bypass passage problems. Four groups of fall chinook salmon weighing 6.1 g (73 fish/lb) were released into the bypass system to assess physical damage caused by passage from the downstream migrant channel to the tailrace. A 200-m purse seine was used to capture the test fish immediately downstream of the bypass outfall of the Second Powerhouse. Recovery percentages of live test fish ranged from 3.7 to 19.5% with a mean of 12.4%. Captured fish (447 total) were examined after about 18 hours of holding in net-pens and after 7 days of holding. In general, the captured fish showed few adverse effects from passage. Percentages of injured, descaled, or dead test fish were no different from those of control fish released into the sampling area without passing through the bypass. Injury and immediate plus delayed mortality was about 5%, and descaling was less than 1% of those recovered. Recovery percentages were generally lower than expected; we believe this was a function of high tailwater elevation (6 m).

Assessments at the First Powerhouse Bypass

Because of the apparent bypass problem at the Second Powerhouse, we also attempted to examine the condition of fish passing Bonneville Dam via the First Powerhouse bypass system. On 19 October 1988, a 10-m trawl was set downstream of the bypass outfall of the First Powerhouse to determine the feasibility of recovering juvenile salmon passing through that system. From the preliminary effort, we believed it would be possible to recover fish released into the system and that injury or mortality caused by the net would be minimal.

On 7 June 1989, a 10-m trawl was used to capture test fish leaving the bypass system. Fall chinook salmon weighing 6 g (73/lb) were released into the bypass channel about 5 m upstream from the downwell. Recovery percentages of the four groups of fish released ranged from 2.5 to 19.7%. Captured fish (391 total) were examined both after about 18 hours of holding in net-pens and after 7 days of holding. Percentages injured, descaled, or dead were no different from those of control fish released into the sampling area. Injury and immediate plus delayed mortality was about 3%, and descaling was about 0.5% of those recovered.