

Library
Northwest & Alaska Fisheries Center
NCAA, National Marine Fisheries Service
2725 Montlake Boulevard, E
Seattle, Washington 98112

Coastal Zone and Estuarine Studies

CZES

**Assessment of Smoltification
and Fitness for Ocean Survival (Quality)
of Chinook and Coho Salmon
and Steelhead
in the Columbia River
and Puget Sound Hatcheries**

PART I Report for FY 1980—81

**PART II Project Summary and
Recommendations (1978—1981)**

by

E.F. Prentice, C.V.W. Mahnken, W.S. Zaugg,
L.C. Folmar, W.W. Dickhoff, F.W. Waknitz,
K.X. Gores, L.W. Harrell, A.J. Novotny,
T.A. Flagg, C.G. Safsten, and J.L. Mighell

July 1981

Library
Northwest & Alaska Fisheries Center
NOAA, National Marine Fisheries Service
2725 Montlake Boulevard, E
Seattle, Washington 98112

ASSESSMENT OF SMOLTIFICATION
AND FITNESS FOR OCEAN SURVIVAL
(QUALITY) OF CHINOOK AND COHO SALMON AND STEELHEAD
IN COLUMBIA RIVER AND PUGET SOUND HATCHERIES
PART I REPORT FOR FY 1980-81
PART II PROJECT SUMMARY AND RECOMMENDATIONS (1978-1981)

by

E. F. Prentice, C. V. W. Mahnken, W. S. Zaugg, L. C. Folmar,
W. W. Dickhoff,^{1/} F. W. Waknitz, K. X. Gores, L. W. Harrell,
A. J. Novotny, T. A. Flagg, C. G. Safsten, and J. L. Mighell

Final Report of Research
Financed by:
Pacific Northwest Regional Commission
(Cooperative Agreements 10890017 and 10990060)

and

Coastal Zone and Estuarine Studies Division
Northwest and Alaska Fisheries Center
National Marine Fisheries Service
National Oceanic and Atmospheric Administration
2725 Montlake Boulevard East
Seattle, Washington 98112

July 1981

^{1/} University of Washington, Department of Zoology, Research Associate,
Seattle, Washington 98195

CONTENTS

PART I. REPORT, FY 80-81

INTRODUCTION.....	1
METHODS.....	1
RESULTS AND DISCUSSION.....	3
Smoltification at the Hatcheries (Appendix A).....	3
Results.....	3
Conclusions.....	6
Physiological Changes in Salmon during Smoltification	
Appendix B.....	7
Results.....	7
Conclusions.....	8
Seawater Adaptation (Appendix C).....	8
Results.....	8
Conclusions.....	9
Fish Health Studies (Appendix D).....	9
Results.....	9
Conclusions.....	10
Biochemical, Morphometric, and Pictorial Documentation of	
Smoltification (Appendix E).....	10
Results.....	10
Conclusions.....	11
Green River Coho Salmon Size-Density Study (Appendix F).....	11
Results.....	11
Conclusions.....	12

REFERENCES..... 13

APPENDIXES

A Freshwater Gill $\text{Na}^+\text{-K}^+$ ATPase Activities and
Migration of Coho and Fall Chinook Salmon from
Selected Hatcheries

B Selected Physiological Changes in Salmon during
Smoltification

C Seawater Adaptation of Fall Chinook Salmon

D Fish Health, A General Evaluation

E Biochemical, Morphological, and Pictorial Documentation
of Smoltification

F Green River Coho Salmon Size-Density Study

PART II SUMMARY AND RECOMMENDATIONS

INTRODUCTION..... 1

SUMMARY..... 5

Gill $\text{Na}^+\text{-K}^+$ ATPase Activities in Salmonids as Related
to Parr-smolt Transformation and Migration..... 5

Thyroid Hormone and Blood Ion Changes in Coho Salmon
during Smoltification..... 7

Seawater Adaptation..... 12

Coho Salmon..... 14

Fall Chinook Salmon..... 15

Spring Chinook Salmon..... 18

Steelhead..... 20

Swimming Performance as an Indicator of Smoltification.....	21
Smoltification Indices.....	21
Effects of Direct Seawater Entry.....	22
Fish Health, A General Evaluation.....	25
RECOMMENDATIONS.....	29
ACKNOWLEDGMENTS.....	33
REFERENCES.....	34

PART I

REPORT FOR FY 1980 - 1981

INTRODUCTION

In 1978, the National Marine Fisheries Service (NMFS), cooperating with the Pacific Northwest Regional Commission (PNRC), initiated a 3-year study to assess the status of smoltification and fitness for ocean survival of chinook salmon, Oncorhynchus tshawytscha; coho salmon, O. kisutch; and steelhead, Salmo gairdneri. The study evaluates various factors believed to influence smoltification, ocean survival, and adult return of anadromous salmonids from hatcheries on the Columbia River and its tributaries.

This report covers work conducted during FY 1980-81, supported by Saltonstall-Kennedy (SK) funds. The primary objectives were as follows:

1. Determine the status of smoltification using gill $\text{Na}^+\text{-K}^+$ ATPase activity, plasma thyroid hormone concentrations, and plasma electrolyte concentrations in fish prior to their release from selected hatcheries.
2. Compare biochemical measures (see Number 1 above) with traditional morphological and behavioral characteristics to determine smoltification at the hatcheries.
3. Determine the seawater adaptability of fish from some of the same hatcheries by monitoring growth, mortality, and reversion to parr in the seminatural conditions of seawater net-pens in Puget Sound.
4. Ascertain the general health profile of each stock at the time of smoltification, immediately prior to hatchery release, and during natural outmigrations in the river and estuary.

METHODS

A total of 31 test groups of coho and fall chinook salmon from 10 state and federal hatcheries were selected for evaluation in 1980 (Table 1,

Table 1--Chinook and coho salmon test groups for 1980.

Hatchery	Stock	Species	Agency	Year	Reason for selection	Date of hatchery release	Date of seawater entry at Manchester	No. of fish repl.		
								No. of fish repl. 1	No. of fish repl. 2	
Cascade	Sandy	Coho salmon	ODFW ^{a/}	1978	Serial release-size study	<u>d/</u>				
Cascade	Sandy	Coho salmon	ODFW	1978	Serial release-size study	<u>d/</u>				
Cascade	Sandy	Coho salmon	ODFW	1978	Serial release-size study	<u>d/</u>				
Toutle	Green River	Coho salmon	WDF ^{b/}	1978	Serial release-size study	5-07-80	<u>e/</u>			
Toutle	Green River	Coho salmon	WDF	1978	Serial release-size study	<u>d/</u>				
Toutle	Green River	Coho salmon	WDF	1978	Serial release-size study	<u>d/</u>				
Washougal	Cowlitz	Coho salmon	WDF	1978	Serial release-size study	5-08-80	<u>e/</u>			
Washougal	Cowlitz	Coho salmon	WDF	1978	Serial release-size study	6-09-80	<u>e/</u>			
Washougal	Cowlitz	Coho salmon	WDF	1978	Serial release-size study	7-07-80	<u>e/</u>			
Big Creek	Big Creek	Coho salmon	ODFW	1978	Serial release-size study	5-07-80	<u>e/</u>			
Big Creek	Big Creek	Coho salmon	ODFW	1978	Serial release-size study	6-06-80	<u>e/</u>			
Big Creek	Big Creek	Coho salmon	ODFW	1978	Serial release-size study	7-07-80	<u>e/</u>			
Green River	Green River	Coho salmon	WDF	1978	Density-size study	4-23-80	<u>e/</u>			
Green River	Green River	Coho salmon	WDF	1978	Density-size study	4-23-80	<u>e/</u>			
Green River	Green River	Coho salmon	WDF	1978	Density-size study	4-23-80	<u>e/</u>			
Green River	Green River	Coho salmon	WDF	1978	Density-size study	4-23-80	<u>e/</u>			
Green River	Green River	Coho salmon	WDF	1978	Density-size study	4-23-80	<u>e/</u>			
Green River	Green River	Coho salmon	WDF	1978	Density-size study	4-23-80	<u>e/</u>			
Green River	Green River	Coho salmon	WDF	1978	Density-size study	4-23-80	<u>e/</u>			
Green River	Green River	Coho salmon	WDF	1978	Density-size study	4-23-80	<u>e/</u>			
Spring Creek	Spring Creek	Fall chinook	USFWS ^{c/}	1979	Serial release study	3-10-80	3-12-80	2	150	150
Spring Creek	Spring Creek	Fall chinook	USFWS	1979	Serial release study	4-10-80	4-10-80	2	150	150
Spring Creek	Spring Creek	Fall chinook	USFWS	1979	Serial release study	5-09-80	5-13-80	2	150	150
Spring Creek	Spring Creek	Fall chinook	USFWS	1979	Serial release study	8-07-80	8-10-80	2	150	150
Bonneville	Bonneville	Fall chinook	ODFW	1979	Hatchery evaluation study	5-13-80	<u>e/</u>			
Bonneville	Bonneville	Fall chinook	ODFW	1979	Hatchery evaluation study	5/22-28/80	<u>e/</u>			
Bonneville	Bonneville	Fall chinook	ODFW	1979	Hatchery evaluation study	<u>d/</u>				
Toutle	Toutle	Fall chinook	WDF	1979	Hatchery evaluation study	<u>d/</u>				
Kalama Falls	Kalama Falls	Fall chinook	WDF	1979	Hatchery evaluation study	<u>d/</u>				
Elokomin	Elokomin	Fall chinook	WDF	1979	Hatchery evaluation study	6-19-80	6-23-80	2	150	150
Grays River	Grays River	Fall chinook	WDF	1979	Hatchery evaluation study	6-24-80	6-26-80	2	150	150

a/ Oregon Department of Fish and Wildlife

b/ Washington Department of Fisheries

c/ U.S. Fish and Wildlife Service

d/ Study group eliminated

e/ No seawater evaluation

Figure 1). However, because of disruptions caused by disease, adverse weather conditions, and Mount St. Helens volcanic eruptions, only 23 test groups from 8 hatcheries were ultimately evaluated (Table 1). Each test group represented a group of fish released from a hatchery.

Detailed methods and materials were presented by CZES and ETSD (1979) and Prentice et al. (1980) and with few exceptions remain the same. Factors used to determine status of smoltification, fish health, and seawater adaptation are summarized in Table 2. Specific changes relating to the various factors are outlined in Appendixes A through F.

RESULTS and DISCUSSION

Detailed discussions of the results are divided by topic and presented in Appendixes A through F. The following is a synopsis of the FY 1980-81 study.

Smoltification at the Hatcheries (Appendix A)

The goals were to monitor changes in the gill Na^+-K^+ ATPase activity of 23 groups of coho and fall chinook salmon from eight state and federal hatcheries, to evaluate their state of smoltification at release, and to relate smoltification state to migration time from the hatchery to the estuary.

Results

1. Coho salmon released from Big Creek and Washougal Hatcheries in June and July showed loss of smolt characteristics (declining gill Na^+-K^+ ATPase activity and loss of external smolt characteristics) at time of release, but moved rapidly in their seaward migration.

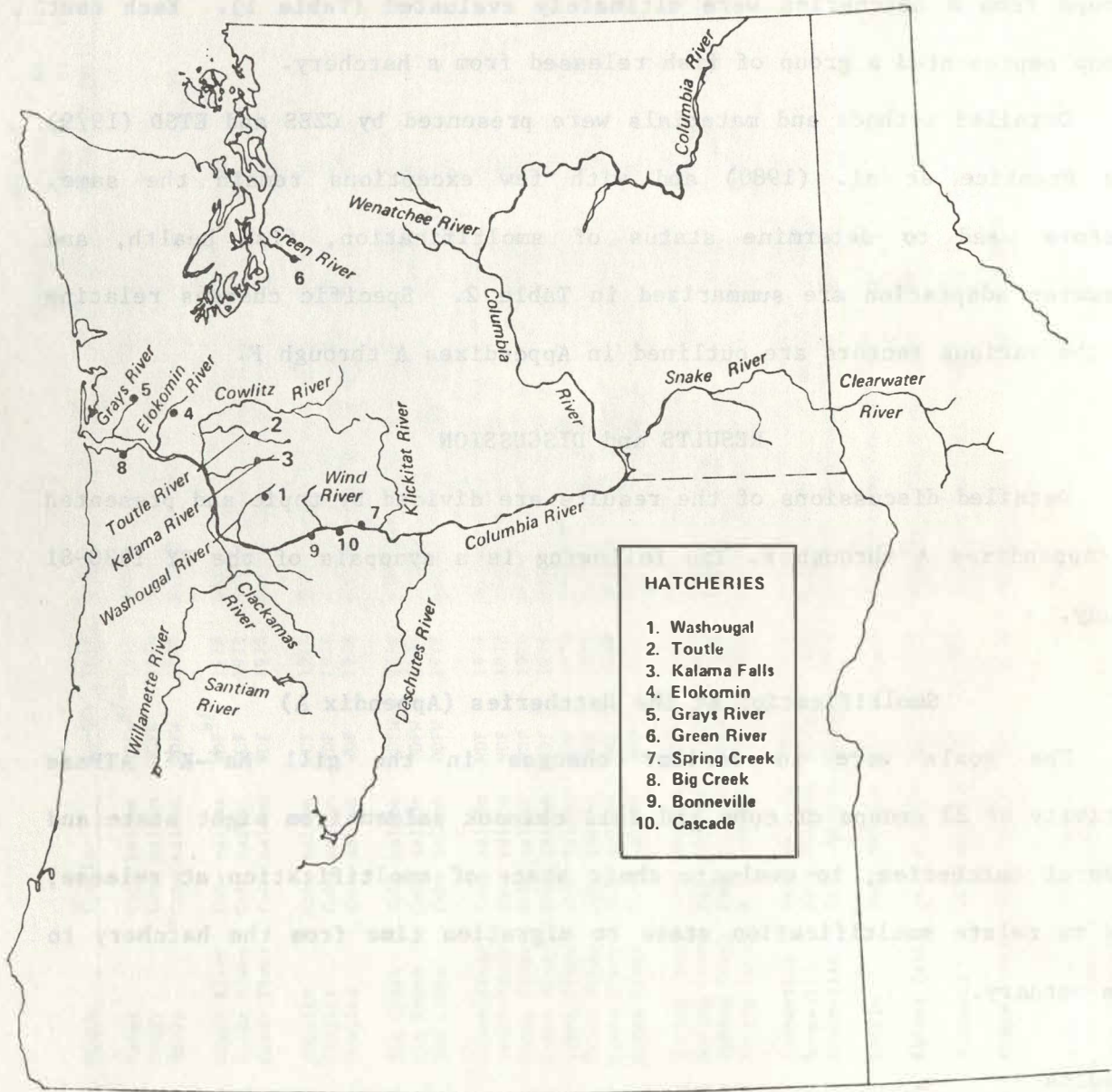

Figure 1.--Location of cooperating hatcheries.

Table 2.--Factors used to determine status of smoltification, fish health, and seawater adaptation.

<u>Study unit</u>	<u>Observation</u>	<u>Technique</u>
Freshwater smolt status	Gill Na^+ - K^+ ATPase	Colorimetric enzyme assay (CEA)
	Thyroxine T_3 and T_4	Radioimmune assay (RIA)
	Blood ions Cl^- , K^+ , and Na^+	Atomic absorption
	Growth	Hatchery records
	Parr-smolt ratio	Hatchery subsample-visual
	Migration time	Recovery of tagged outmigrants in estuary
Seawater adaptation	Documentation of status of smoltification	Photographic, biochemical, and morphometric characterization
	Blood ion Cl^- , K^+ , Na^+ , Ca^{++} , and Mg^{++}	Atomic absorption
	Survival	Daily counts of mortalities
	Parr-smolt ratios	Monthly counts-visual
	Growth and condition index	Monthly length-weight measurements
	Documentation of status of smoltification	Photographic and morphometric characterization
	Freshwater and seawater diseases	Freshwater disease profiles
Hematology (hematocrit and hemoglobin)		Standard hematological methods
Presence of bacterial disease		Agar plates, post mortems, and fluorescent antibody technique

2. Coho salmon migrants from Big Creek and Washougal Hatcheries captured in the Columbia River estuary at Jones Beach [River Kilometer (Rkm) 76] showed rising gill Na^+-K^+ ATPase activity and reappearance of external smolt characteristics. Thus, rapid resmoltification occurred shortly after release.

3. Peak gill Na^+-K^+ ATPase activity of coho salmon from Big Creek Hatchery occurred 3 to 4 weeks later than in past years even though the fish were larger.

4. No dramatic changes in gill Na^+-K^+ ATPase activity were seen in fall chinook salmon from Bonneville, Elokomín, or Grays River Hatcheries.

5. At Jones Beach, the recovery of fish released from Spring Creek National Fish Hatchery (NFH) was advanced about 10 days over past years; however, the fish were released 10 days earlier and were larger at release than in past years.

6. In 1980, gill Na^+-K^+ ATPase peak activity in Spring Creek fall chinook salmon was different in both timing and value from the previous 2 years.

7. Fall chinook salmon at Spring Creek NFH fed a 7% salt-supplemented diet for 4 weeks prior to release in March showed a significant elevation in gill Na^+-K^+ ATPase activity compared to fish fed a diet without a salt supplement.

Conclusions

1. Timing of the parr-smolt transformation is dependent on genetic stock, husbandry, and environmental conditions at each hatchery. This

transformation, however, can be affected by the release of the fish from the hatchery environment.

2. Coho salmon held in the hatchery beyond the gill $\text{Na}^+\text{-K}^+$ ATPase peak revert from a smolted condition to a transitional or parr stage. Up to a point, however, reversion to parr is not irreversible, as some fish smolt rapidly after release from the hatchery during movement to the estuary.

3. If the fall chinook salmon from Bonneville, Elokomín, and Grays River Hatcheries had been held longer, gill $\text{Na}^+\text{-K}^+$ ATPase activity probably would have risen, unless husbandry or environmental factors depressed the activity.

4. The change in the period of migration in Spring Creek fall chinook salmon was due to the fish being released from the hatchery 10 days earlier than in past years because of their larger size.

5. Salt (NaCl) added to the diet of fall chinook salmon can stimulate gill $\text{Na}^+\text{-K}^+$ ATPase activity.

Physiological Changes in Salmon during Smoltification (Appendix B)

The goal was to monitor plasma thyroxine (T_4) and blood ion levels in yearling coho salmon during smoltification.

Results

1. All release groups at both Big Creek and Washougal Hatcheries showed variable patterns in plasma T_4 concentrations.

2. The Big Creek Hatchery test groups showed early springtime T_4 increases but no separate peak by the time of the May releases. The T_4

peak of the June and July groups occurred in late May and returned to basal levels by the time of release.

3. The May release from Washougal Hatchery was soon after the peak of the T_4 cycle. The June release was 1 month after the first T_4 peak, and the July release was 1 month after a small secondary T_4 peak.

4. Blood ion levels showed no consistent relationships to smoltification.

Conclusions

1. The June release from Big Creek Hatchery was probably near the optimal time for seawater adaptation, based on the T_4 cycle.

2. By a similar evaluation, the May release from Washougal Hatchery was probably near the optimal time to give best seawater adaptation.

3. It must be cautioned that the basis for prediction of the suitability of release time (T_4 cycle) was derived from studies in which fish were transferred directly from the hatchery to seawater net-pens.

Seawater Adaptation (Appendix C)

The goal was to evaluate the seawater adaptability of fall chinook salmon using growth, survival, and status of smoltification as criteria. Six groups of fall chinook salmon from three hatcheries were evaluated in seawater (29 ‰) for up to 40 days.

Results

1. External symptoms of osmoregulatory dysfunction (dehydration) were seen for up to 15 days of seawater residence.

2. Test groups with elevated gill Na^+-K^+ ATPase activity at the time of direct seawater entry had the lowest mortality.

3. Normally, osmoregulatory problems most severely affected the smaller fish in a test population.

Conclusions

1. A 30- to 40-day evaluation in seawater appears to be adequate to determine the seawater adaptability of fall chinook salmon.

2. External symptoms of osmoregulatory dysfunction can be seen for up to 15 days in seawater.

3. There was again, as in the past, a positive relationship between gill $\text{Na}^+\text{-K}^+$ ATPase activity and seawater adaptability for fall chinook salmon.

4. Mortality following the initial 10 to 15 days of seawater residence was related to vibriosis.

5. Initial survival of fall chinook salmon introduced directly to seawater is dependent on size, time of entry, and status of smoltification. These factors are interrelated in a complex way and it is difficult at this time to make absolute statements about any single factor.

Fish Health Studies (Appendix D)

The goals were to monitor fish health to determine whether the fish were compromised by disease at the time of hatchery release and to determine the occurrence of disease in fish held in seawater.

Results

1. The incidence of bacterial kidney disease (BKD) in fresh water ranged from 0 to 13% among the groups evaluated.

2. BKD was not seen in fall chinook salmon held in seawater in 1980.

3. Vibriosis was isolated in fall chinook salmon held in seawater.

Incidence of the disease increased as seawater warmed to 13°-15°C.

Conclusions

1. BKD can be found in fish residing in either fresh water or seawater. It normally does not manifest itself, however, before 40 days of seawater residence. It is therefore possible that the fish tested were latent carriers of BKD but were not in seawater long enough for the disease to become apparent.

2. The total impact of BKD in either fresh water or seawater is unknown.

3. The test groups monitored in this study were not compromised by disease when released from the hatcheries. We therefore believe that the indices of smoltification used in the study adequately represent the fish released.

4. Vibriosis was the primary pathogen present in fall chinook salmon held in seawater. An increased incidence of the disease was directly related to rising seawater temperatures.

Biochemical, Morphometric, and Pictorial

Documentation of Smoltification (Appendix E)

The goal was to document the parr-smolt transformation of coho salmon using photographs and morphological and physiological measurements.

Results

1. Descriptions of the various stages of smoltification were prepared along with photographs depicting parr, transitional, and smolt stages in fresh water and seawater.

2. Fish samples representing each stage of the parr-smolt transformation in both fresh water and seawater were preserved for later morphological measurements.

3. Tissue and blood samples from fish representing each stage of the parr-smolt transformation in fresh water were taken for T₃, T₄, and blood ion analyses.

Conclusions

1. Lighting and orientation of the fish are critical to proper visual identification of external characteristics of smoltification.

2. Seven stages of smoltification were identified in fresh water and five in seawater by visual external characteristics. The stages classified in fresh water were: (1) parr, (2) transitional, (3) smolt #1, (4) smolt #2, (5) smolt #3, (6) reverted transitional, and (7) reverted parr. In seawater the stages were identified as: (1) seawater parr (stunt), (2) seawater parr (reverted), (3) seawater transitional, (4) seawater transitional (reverted), and (5) seawater smolt.

3. Results and conclusions obtained from morphological and biochemical samples representing the various stages of smoltification will be presented in an addendum (September 1981).

Green River Coho Salmon Size-Density Study (Appendix F)

The goal was to determine the effect on smoltification of both the loading density and the fish size at release.

Results

1. A high incidence of furunculosis caused mortality among all test

groups early in the study. The mortality that occurred was not related to density or size.

2. Low dissolved oxygen in the raceways necessitated early release of the fish.

3. Projected sizes of the fish at release were achieved; loading densities, however, were not.

4. Plasma T_4 levels within test groups of smaller size fish (18 to 19 g) showed either no change or only slight increases during April.

5. Distinct springtime peaks in plasma T_4 levels were seen only in test groups of large fish (24 to 27 g). Peak plasma T_4 concentrations occurred in mid-April.

6. Gill Na^+-K^+ ATPase activity levels had only risen slightly at the time of release indicating that smoltification had begun. Retaining the fish at the hatchery about 1 week longer might have resulted in a significant elevation in gill Na^+-K^+ ATPase activity. This was impractical, however, because of low oxygen levels in the raceways.

Conclusions

1. Failure to obtain projected loading densities prevented analysis of any density effect on smoltification.

2. Projected average fish sizes were reached or exceeded; however, the effects on smoltification of size at release cannot be measured because of the premature release (based on gill Na^+-K^+ ATPase activity).

3. Failure of the smaller fish to show distinct springtime plasma T_4 peaks compared to larger fish, suggests that the development of the smaller fish was retarded. The data suggest that the smaller fish should have been released at a later date than the larger fish.

REFERENCES

Coastal Zone and Estuarine Studies Division and Environmental and Technical Services Division.

1979. A study to assess status of smoltification and fitness for ocean survival of chinook, coho, and steelhead. Project 817. Coastal Zone and Estuarine Studies Division, Northwest and Alaska Fisheries Center, 403 p. (Processed).

Prentice, E. F., C. Mahnken, K. Gores, W. Waknitz, L. Folmar, R. King, J. Mighell, W. Dickhoff, T. Flagg, L. Harrell, A. Novotny, D. Damkaer, E. Wold, and R. Vreeland.

1980. A study to assess status of smoltification and fitness for ocean survival of chinook and coho salmon and steelhead. FY 1979-80, Project 10990060. Coastal Zone and Estuarine Studies Division, Northwest and Alaska Fisheries Center, 408 p. (Processed).

APPENDIX A

FRESHWATER GILL $\text{Na}^+ - \text{K}^+$ ATPase ACTIVITIES AND MIGRATION
OF COHO AND FALL CHINOOK SALMON FROM SELECTED HATCHERIES

by

W. S. Zaugg

INTRODUCTION

For the past 3 years studies to determine the status of smoltification of salmonids using gill $\text{Na}^+\text{-K}^+$ ATPase activity have been conducted on selected groups of hatchery reared fish (CZES and ETSD 1979 and Prentice et al. 1980). These studies have provided insight to the relationship between smolt condition at release and performance during outmigration (Dawley et al. 1980).

The objective of this year's study was to further evaluate the status of smoltification of hatchery reared salmon using gill $\text{Na}^+\text{-K}^+$ ATPase as an indicator and to further document the phenomenon of resmoltification. In several instances, results are compared with data obtained in previous years.

METHODS AND MATERIALS

Coho salmon and fall chinook salmon were evaluated in the study (Table A1). Biochemical analyses to determine status of smoltification were conducted on random samples of fish from each test group prior to normal hatchery release. Analyses were also conducted on out-migrating fish captured in the Columbia River estuary at Jones Beach 76 km from the river's mouth. Numbers of fish caught at Jones Beach are presented as actual and adjusted numbers of fish. The adjusted number takes into account fishing effort and efficiency.

Samples were taken for gill $\text{Na}^+\text{-K}^+$ ATPase, plasma thyroxine (T_4), triiodothyronine (T_3) and mono- and divalent ions. Results of the gill $\text{Na}^+\text{-K}^+$ ATPase analyses will be discussed in this Appendix; other biochemical results will be discussed in Appendix B. Tissue sampling and gill $\text{Na}^+\text{-K}^+$ ATPase analyses were conducted as previously described

Table A1--Chinook and coho salmon test groups for 1980.

Hatchery	Stock	Species	Agency	Year	Reason for selection	Date of hatchery release	Date of seawater entry at Manchester	No. of repl.	No. of fish repl. 1	No. of fish repl. 2
Cascade	Sandy	Coho salmon	ODFW ^{a/}	1978	Serial release-size study	<u>d/</u>				
Cascade	Sandy	Coho salmon	ODFW	1978	Serial release-size study	<u>d/</u>				
Cascade	Sandy	Coho salmon	ODFW	1978	Serial release-size study	<u>d/</u>				
Toutle	Green River	Coho salmon	WDF ^{b/}	1978	Serial release-size study	5-07-80	<u>e/</u>			
Toutle	Green River	Coho salmon	WDF	1978	Serial release-size study	<u>d/</u>				
Toutle	Green River	Coho salmon	WDF	1978	Serial release-size study	<u>d/</u>				
Washougal	Cowlitz	Coho salmon	WDF	1978	Serial release-size study	5-08-80	<u>e/</u>			
Washougal	Cowlitz	Coho salmon	WDF	1978	Serial release-size study	6-09-80	<u>e/</u>			
Washougal	Cowlitz	Coho salmon	WDF	1978	Serial release-size study	7-07-80	<u>e/</u>			
Big Creek	Big Creek	Coho salmon	ODFW	1978	Serial release-size study	5-07-80	<u>e/</u>			
Big Creek	Big Creek	Coho salmon	ODFW	1978	Serial release-size study	6-06-80	<u>e/</u>			
Big Creek	Big Creek	Coho salmon	ODFW	1978	Serial release-size study	7-07-80	<u>e/</u>			
Green River	Green River	Coho salmon	WDF	1978	Density-size study	4-23-80	<u>e/</u>			
Green River	Green River	Coho salmon	WDF	1978	Density-size study	4-23-80	<u>e/</u>			
Green River	Green River	Coho salmon	WDF	1978	Density-size study	4-23-80	<u>e/</u>			
Green River	Green River	Coho salmon	WDF	1978	Density-size study	4-23-80	<u>e/</u>			
Green River	Green River	Coho salmon	WDF	1978	Density-size study	4-23-80	<u>e/</u>			
Green River	Green River	Coho salmon	WDF	1978	Density-size study	4-23-80	<u>e/</u>			
Green River	Green River	Coho salmon	WDF	1978	Density-size study	4-23-80	<u>e/</u>			
Green River	Green River	Coho salmon	WDF	1978	Density-size study	4-23-80	<u>e/</u>			
Spring Creek	Spring Creek	Fall chinook	USFWS ^{c/}	1979	Serial release study	3-10-80	3-12-80	2	150	150
Spring Creek	Spring Creek	Fall chinook	USFWS	1979	Serial release study	4-10-80	4-10-80	2	150	150
Spring Creek	Spring Creek	Fall chinook	USFWS	1979	Serial release study	5-09-80	5-13-80	2	150	150
Spring Creek	Spring Creek	Fall chinook	USFWS	1979	Serial release study	8-07-80	8-10-80	2	150	150
Bonneville	Bonneville	Fall chinook	ODFW	1979	Hatchery evaluation study	5-13-80	<u>e/</u>			
Bonneville	Bonneville	Fall chinook	ODFW	1979	Hatchery evaluation study	5/22-28/80	<u>e/</u>			
Bonneville	Bonneville	Fall chinook	ODFW	1979	Hatchery evaluation study	<u>d/</u>				
Toutle	Toutle	Fall chinook	WDF	1979	Hatchery evaluation study	<u>d/</u>				
Kalama Falls	Kalama Falls	Fall chinook	WDF	1979	Hatchery evaluation study	<u>d/</u>				
Elokomin	Elokomin	Fall chinook	WDF	1979	Hatchery evaluation study	6-19-80	6-23-80	2	150	150
Grays River	Grays River	Fall chinook	WDF	1979	Hatchery evaluation study	6-24-80	6-26-80	2	150	150

a/ Oregon Department of Fish and Wildlife

b/ Washington Department of Fisheries

c/ U.S. Fish and Wildlife Service

d/ Study group eliminatede/ No seawater evaluation

(CZES and ETSD 1979). Enzymatic activities are reported as μ moles ATP hydrolyzed . mg protein⁻¹.h⁻¹.

RESULTS AND DISCUSSION

The results of this year's study are presented in a Smolt Evaluation Summary (SES) and an explanatory discussion for each test group.

Coho Salmon

Coho salmon scheduled for serial release at the Toutle and Washougal Hatcheries in Washington, and the Big Creek and Cascade Hatcheries in Oregon were examined for gill $\text{Na}^+\text{-K}^+$ ATPase activities during the spring and early summer of 1979 (Prentice et al. 1980). These studies were repeated in 1980 (Table A1). Coho salmon at Cascade Hatchery were scheduled for sampling in 1980. The hatchery was deleted, however, when icing conditions at the hatchery caused high mortality.

Coho salmon at the Green River Hatchery were part of a size-density study conducted by the Washington Department of Fisheries (WDF). Results and discussion of the study are presented in Appendix F.

Toutle Hatchery (SES 1)

Data were collected from 13 March to 5 May on coho salmon scheduled for May, June, and July releases. On 18 May, Mount St. Helens erupted causing massive mud flows and flooding in the Toutle River. The Toutle Hatchery was buried under mud, and all fish remaining in the hatchery were killed. Only coho salmon released on 7 May had any chance of survival. Gill $\text{Na}^+\text{-K}^+$ ATPase information to 5 May is plotted in Figure A1 and compared to the gill $\text{Na}^+\text{-K}^+$ ATPase curve observed in 1979 for the May

SMOLT EVALUATION SUMMARY 1

HATCHERY: Toutle SPECIES: Coho STOCK: Green River
 DIET: OMP POND #: 9
 RELEASE DATE: 7 May 1980 CODED WIRE TAG: 63-19-31
 Number released: 38,612

SUMMARY OF GILL Na⁺ - K⁺ ATPase (μmoles P_i · mg protein⁻¹ · hr⁻¹)

At hatchery:

<u>Low</u>	<u>Date</u>	<u>High</u>	<u>Date</u>	<u>At release</u>	<u>Date</u>
6.5	13 Mar	10.9	5 May	≈11	7 May

In seawater:

Number of days: NA _____
 Na⁺ - K⁺ ATPase: _____
 % mortality: _____

SIZE OF FISH SAMPLED FOR ATPase NEAR TIME OF HATCHERY RELEASE:

	<u>AVERAGE</u>	<u>RANGE</u>
Weight (g):	---	---
Fork length (mm):	140.0	120.0 - 147.0
Date:	5 May 1980	

TAGGED FISH CAPTURED AT JONES BEACH:

Date captured:	<u>5/13</u>	<u>5/14</u>	<u>5/15</u>	<u>5/16</u>	<u>5/17</u>	<u>5/19</u>
Number of fish: (actual)	<u>1</u>	<u>2</u>	<u>4</u>	<u>8</u>	<u>21</u>	<u>7</u>
Mean fork length (mm):	_____	_____	_____	_____	_____	_____
Mean Na ⁺ - K ⁺ ATPase:	_____	_____	_____	_____	_____	_____
Mean Plasma T ₃	_____	_____	_____	_____	_____	_____
Mean Plasma T ₄	_____	_____	_____	_____	_____	_____

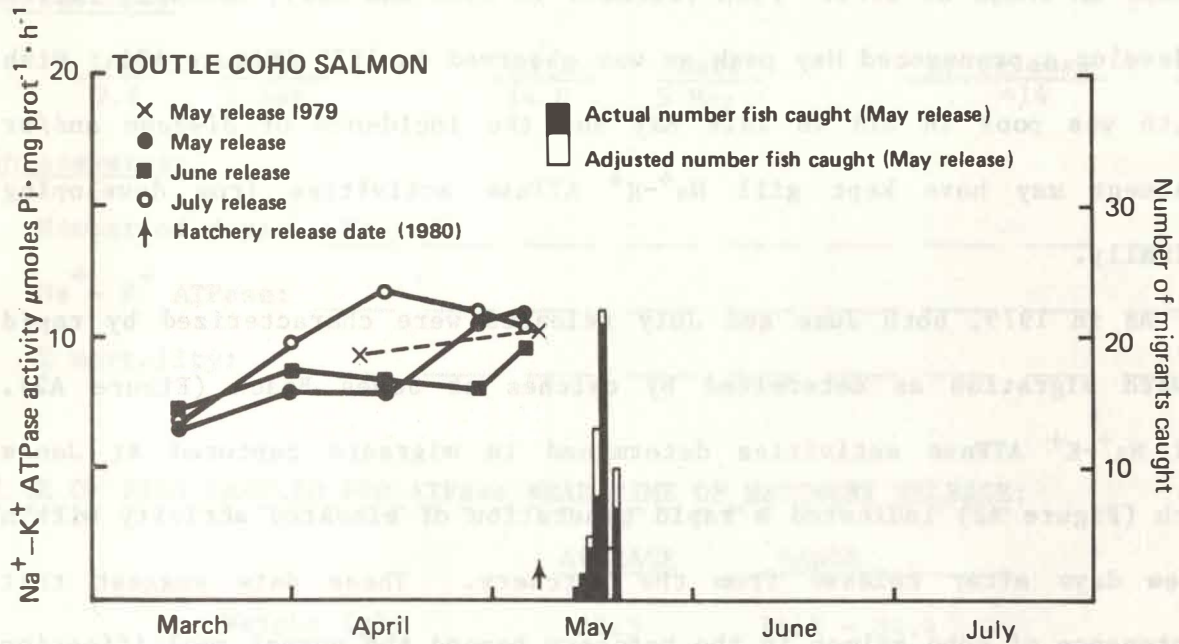

Figure A1.--Gill $\text{Na}^+ - \text{K}^+$ ATPase activities in coho salmon from the Toutle Hatchery and numbers of migrants captured at Jones Beach in 1980. Data from the 1979 study are shown for comparison. Adjusted number corrects total number of fish captured for fishing effort and efficiency.

release fish. Actual and adjusted numbers of fish caught at Jones Beach (Oregon) are also plotted in Figure A1.

Washougal Hatchery (SES 2, 3, and 4)

In general, gill $\text{Na}^+\text{-K}^+$ ATPase activity profiles observed this year for the three release groups (May, June, and July) were qualitatively similar to those of 1979. Fish released in June and July, however, failed to develop a pronounced May peak as was observed in 1979 (Figure A2). Fish health was poor in mid to late May and the incidence of disease and/or treatment may have kept gill $\text{Na}^+\text{-K}^+$ ATPase activities from developing maximally.

As in 1979, both June and July releases were characterized by rapid seaward migration as determined by catches at Jones Beach (Figure A2). Gill $\text{Na}^+\text{-K}^+$ ATPase activities determined in migrants captured at Jones Beach (Figure A2) indicated a rapid generation of elevated activity within a few days after release from the hatchery. These data suggest that maintenance of coho salmon in the hatchery beyond the normal smoltification time in May results in deterioration of smolt condition, indicated by decreasing gill $\text{Na}^+\text{-K}^+$ ATPase values. However, reversion to a parr-type animal was not an irreversible process since these fish were capable of very rapid smoltification shortly after release. Gill $\text{Na}^+\text{-K}^+$ ATPase activities elevated much more rapidly during this resmoltification than during the first parr to smolt transformation in late April and early May. The rate of enzyme activity elevation in the July migrants is undoubtedly accelerated by warmer water (Zaugg and McLain 1976), but the ability to rapidly resmolt may also be a result of at least partial retention of some of the physiological changes which resulted during initial smolt development in April.

SMOLT EVALUATION SUMMARY 2

HATCHERY: Washougal SPECIES: Coho STOCK: Cowlitz

DIET: POND #: 19

RELEASE DATE: 8 May 1980 CODED WIRE TAG: 63-20-39

Number released: 99,638

SUMMARY OF GILL Na⁺ - K⁺ ATPase (μmoles P_i · mg protein⁻¹ · hr⁻¹)

At hatchery:

<u>Low</u>	<u>Date</u>	<u>High</u>	<u>Date</u>	<u>At release</u>	<u>Date</u>
7.6	1 Apr	14.0	5 May	≈14	8 May

In seawater:

Number of days: NA _____

Na⁺ - K⁺ ATPase: _____

% mortality: _____

SIZE OF FISH SAMPLED FOR ATPase NEAR TIME OF HATCHERY RELEASE:

	<u>AVERAGE</u>	<u>RANGE</u>
Weight (g):	23.5	11.2 - 34.4
Fork length (mm):	133.0	105.0 - 153.0
Date:	5 May 1980	

TAGGED FISH CAPTURED AT JONES BEACH:

Date captured: 5/13 to 5/28 _____

Number of fish: (actual) 51 _____

Mean fork length (mm): _____

Mean Na⁺ - K⁺ ATPase: _____

Mean Plasma T₃ _____

Mean Plasma T₄ _____

SMOLT EVALUATION SUMMARY 3

HATCHERY: Washougal SPECIES: Coho STOCK: Cowlitz
 DIET: POND #: 21
 RELEASE DATE: 9 June 1980 CODED WIRE TAG: 63-20-38
 Number Released: 97,823

SUMMARY OF GILL Na⁺ - K⁺ ATPase (μmoles P_i · mg protein⁻¹ · hr⁻¹)

At hatchery:

<u>Low</u>	<u>Date</u>	<u>High</u>	<u>Date</u>	<u>At release</u>	<u>Date</u>
8.1	5 June	11.3	5 May	≈ 8	9 June

In seawater:

Number of days: NA _____
 Na⁺ - K⁺ ATPase: _____
 % mortality: _____

SIZE OF FISH SAMPLED FOR ATPase NEAR TIME OF HATCHERY RELEASE:

	<u>AVERAGE</u>	<u>RANGE</u>
Weight (g):	23.3	12.4-30.0
Fork length (mm):	134	110-145
Date:	5 June 1980	

TAGGED FISH CAPTURED AT JONES BEACH:

Date captured: 6/13 to 6/19 _____
 Number of fish: (Actual) 65 _____
 Mean fork length (mm): _____
 Mean Na⁺ - K⁺ ATPase: _____
 Mean Plasma T₃ _____
 Mean Plasma T₄ _____

SMOLT EVALUATION SUMMARY 4

HATCHERY: Washougal SPECIES: Coho STOCK: Cowlitz
 DIET: POND #: 23
 RELEASE DATE: 7 July 1980 CODED WIRE TAG: 63-19-55
 NUMBER RELEASED: 100,020

SUMMARY OF GILL Na⁺ - K⁺ ATPase (μmoles P_i · mg protein⁻¹ · hr⁻¹)

At hatchery:

<u>Low</u>	<u>Date</u>	<u>High</u>	<u>Date</u>	<u>At release</u>	<u>Date</u>
6.5	3 July	11.9	5 May	~ 6	7 July

In seawater:

Number of days:	NA	_____	_____	_____	_____	_____
Na ⁺ - K ⁺ ATPase:	_____	_____	_____	_____	_____	_____
% mortality:	_____	_____	_____	_____	_____	_____

SIZE OF FISH SAMPLED FOR ATPase NEAR TIME OF HATCHERY RELEASE:

	<u>AVERAGE</u>	<u>RANGE</u>
Weight (g):	25.3	17.1-33.1
Fork length (mm):	137	120-148
Date:	3 July 1980	

TAGGED FISH CAPTURED AT JONES BEACH:

	<u>Total</u>	<u>For ATPase</u>	
	<u>7/10 to 8/15</u>	<u>7/11</u>	<u>7/15</u>
Date captured:	_____	_____	_____
Number of fish: (Actual)	114	30	30
Mean fork length (mm):	_____	_____	_____
Mean Na ⁺ - K ⁺ ATPase:	_____	9.6	17.4
Mean Plasma T ₃	_____	_____	_____
Mean Plasma T ₄	_____	_____	_____

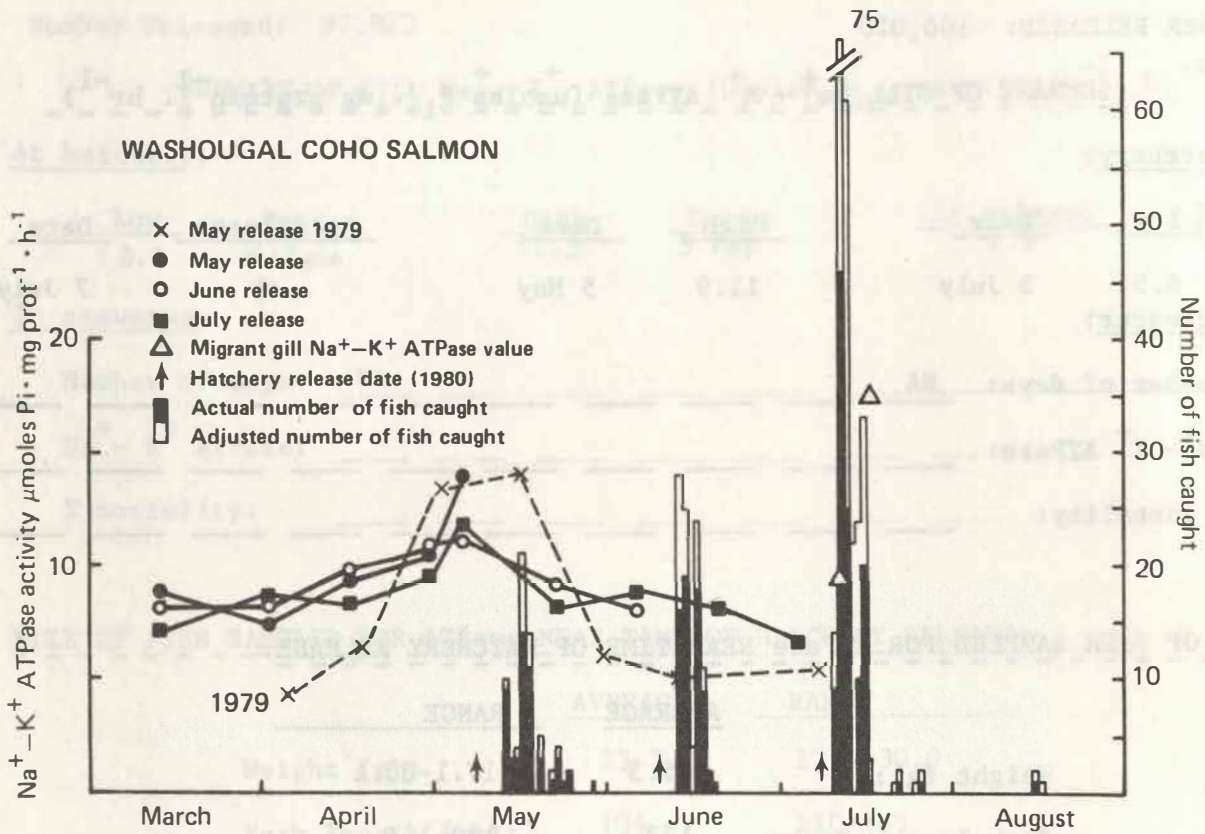

Figure A2.-- Gill $\text{Na}^+ - \text{K}^+$ ATPase activities in coho salmon from the Washougal Hatchery and numbers of tagged migrants captured at Jones Beach in 1980. Data from the 1979 study are shown for comparison. Single points (Δ) show average gill $\text{Na}^+ - \text{K}^+$ ATPase activities for 30 migrants captured on the indicated dates (1980) at Jones Beach. Adjusted number corrects total number of fish captured for fishing effort and efficiency.

Big Creek (SES 5, 6, and 7)

The development of peak gill Na^+-K^+ ATPase activity in Big Creek coho salmon occurred about 1 month later in the June and July release this year compared to the July release in 1979 (Figure A3). Again this year, since releases were made at the hatchery, no recaptures were possible because of location of the release site with respect to the capture location at Jones Beach.

Fall Chinook Salmon

Studies for 1980 were scheduled at 6 hatcheries. The eruption of Mount St. Helens caused cancellation of sampling at the Toutle and Kalama Falls Hatcheries.

Elokomin Hatchery (SES 8)

Fall chinook salmon from Elokomin Hatchery showed a gradual elevation in gill Na^+-K^+ ATPase activity from the initial sampling until release (Figure A4). Activities were lower this year than in 1979 even though sampled fish were larger. There were no tag recoveries at Jones Beach because of the location of the hatchery with respect to the recovery area.

Grays River Hatchery (SES 9)

This is the first year that gill Na^+-K^+ ATPase activities have been monitored in fall chinook salmon at Grays River Hatchery. Up to the time of release on 24 June (Ponds 4 through 11), no elevation in activity was evident (Figure A5). Two other fall chinook salmon releases carrying tags with the same code as the 24 June release were made from this hatchery. These releases were made on 1 June (Pond 13) and 3 June (Pond 12). Single gill Na^+-K^+ ATPase values were determined for these groups

SMOLT EVALUATION SUMMARY 5

HATCHERY: Big Creek SPECIES: Coho STOCK: Big Creek
DIET: OMP POND #: 9A
RELEASE DATE: 7 May 1980 CODED WIRE TAG: 7-19-52
NUMBER RELEASED: 28,736

SUMMARY OF GILL Na⁺ - K⁺ ATPase (μmoles P_i · mg protein⁻¹ · hr⁻¹)

At hatchery:

<u>Low</u>	<u>Date</u>	<u>High</u>	<u>Date</u>	<u>At release</u>	<u>Date</u>
8.2	7 March	14.7	5 May	≈ 15	7 May

In seawater:

Number of days: NA
Na⁺ - K⁺ ATPase: _____
% mortality: _____

SIZE OF FISH SAMPLED FOR ATPase NEAR TIME OF HATCHERY RELEASE:

	<u>AVERAGE</u>	<u>RANGE</u>
Weight (g):	25.2	18.6-31.5
Fork length (mm):	134	120-145
Date:	5 May 1980	

TAGGED FISH CAPTURED AT JONES BEACH:

Date captured: No captures
Number of fish: _____
Mean fork length (mm): _____
Mean Na⁺ - K⁺ ATPase: _____
Mean Plasma T₃: _____
Mean Plasma T₄: _____

SMOLT EVALUATION SUMMARY 6

HATCHERY: Big Creek SPECIES: Coho STOCK: Big Creek
 DIET: OMP POND #: 9B
 RELEASE DATE: 6 June 1980 CODED WIRE TAG: 7-19-53
 NUMBER RELEASED: 26,477

SUMMARY OF GILL Na⁺ - K⁺ ATPase (μmoles P_i · mg protein⁻¹ · hr⁻¹)

At hatchery:

<u>Low</u>	<u>Date</u>	<u>High</u>	<u>Date</u>	<u>At release</u>	<u>Date</u>
8.0	7 March	16.6	22 May	15	6 June

In seawater:

Number of days: NA _____
 Na⁺ - K⁺ ATPase: _____
 % mortality: _____

SIZE OF FISH SAMPLED FOR ATPase NEAR TIME OF HATCHERY RELEASE:

	<u>AVERAGE</u>	<u>RANGE</u>
Weight (g):	24.8	12.3-34.3
Fork length (mm):	135	110-150
Date: 6 June 1980		

TAGGED FISH CAPTURED AT JONES BEACH:

Date captured: No captures _____
 Number of fish: _____
 Mean fork length (mm): _____
 Mean Na⁺ - K⁺ ATPase: _____
 Mean Plasma T₃ _____
 Mean Plasma T₄ _____

SMOLT EVALUATION SUMMARY 7

HATCHERY: Big Creek SPECIES: Coho STOCK: Big Creek
 DIET: OMP POND #: 11A
 RELEASE DATE: 7 July 1980 CODED WIRE TAG: 7-19-54
 NUMBER RELEASED: 27,913

SUMMARY OF GILL Na⁺ - K⁺ ATPase (μmoles P_i · mg protein⁻¹ · hr⁻¹)

At hatchery:

<u>Low</u>	<u>Date</u>	<u>High</u>	<u>Date</u>	<u>At release</u>	<u>Date</u>
8.2	7 July	17.4	4 June	8.2	7 July

In seawater:

Number of days: NA

Na⁺ - K⁺ ATPase: _____

% mortality: _____

SIZE OF FISH SAMPLED FOR ATPase NEAR TIME OF HATCHERY RELEASE:

	<u>AVERAGE</u>	<u>RANGE</u>
Weight (g):	26.1	19.7-33.1
Fork length (mm):	138	126-149
Date: 7 July 1980		

TAGGED FISH CAPTURED AT JONES BEACH:

<u>Date captured:</u>	<u>No captures</u>	<u>Date captured:</u>
Number of fish:	_____	_____
Mean fork length (mm):	_____	_____
Mean Na ⁺ - K ⁺ ATPase:	_____	_____
Mean Plasma T ₃	_____	_____
Mean Plasma T ₄	_____	_____

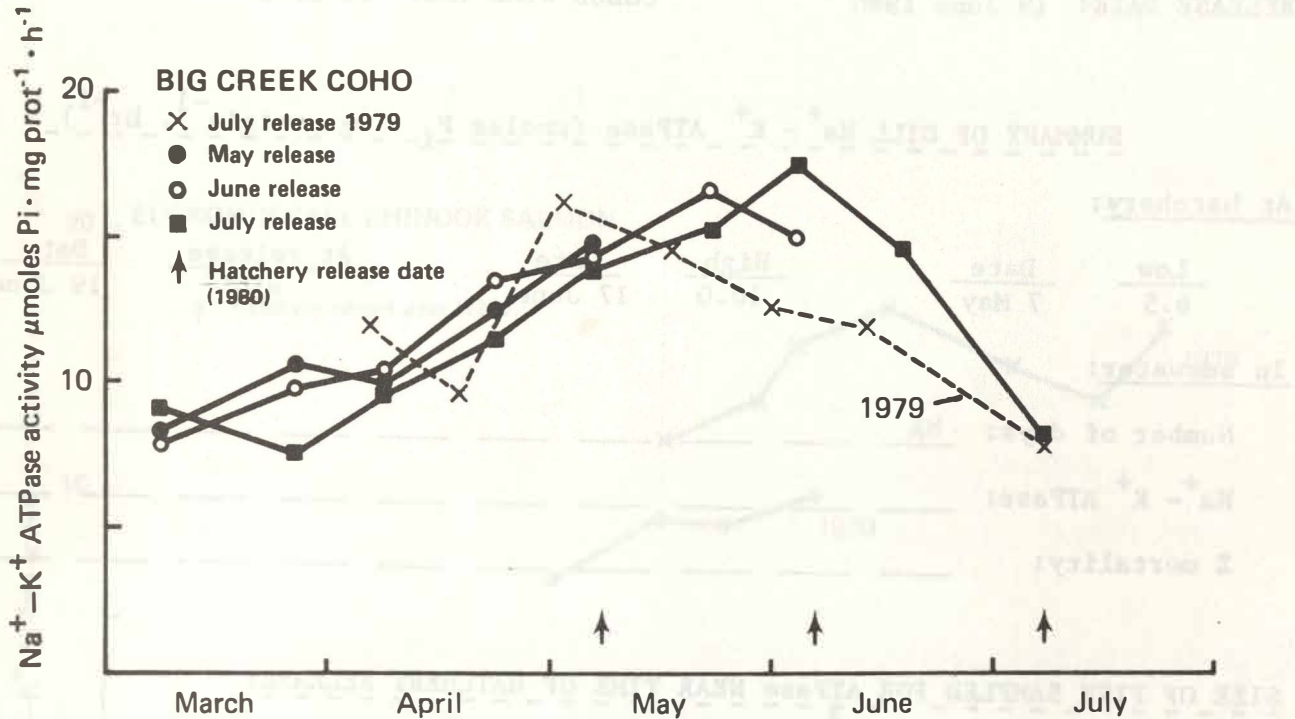

Figure A3.--Gill Na^+-K^+ ATPase activities in coho salmon from the Big Creek Hatchery in 1980. Data from the 1979 study are shown for comparison.

SMOLT EVALUATION SUMMARY 8

HATCHERY: Elokomin

SPECIES: Fall chinook STOCK: Elokomin

DIET:

POND #: Adult holding pond

RELEASE DATE: 19 June 1980

CODED WIRE TAG: 63-20-5

SUMMARY OF GILL Na⁺ - K⁺ ATPase ($\mu\text{moles P}_i \cdot \text{mg protein}^{-1} \cdot \text{hr}^{-1}$)

At hatchery:

<u>Low</u>	<u>Date</u>	<u>High</u>	<u>Date</u>	<u>At release</u>	<u>Date</u>
6.5	7 May	10.0	17 June	≈10	19 June

In seawater:

Number of days: NA _____

Na⁺ - K⁺ ATPase: _____

% mortality: _____

SIZE OF FISH SAMPLED FOR ATPase NEAR TIME OF HATCHERY RELEASE:

	<u>AVERAGE</u>	<u>RANGE</u>
Weight (g):	7.0	3.0 - 9.6
Fork length (mm):	85.0	67.0 - 95.0
Date: 17 June 1980		

TAGGED FISH CAPTURED AT JONES BEACH:

Date captured: No captures _____

Number of fish: _____

Mean fork length (mm): _____

Mean Na⁺ - K⁺ ATPase: _____

Mean Plasma T₃: _____

Mean Plasma T₄: _____

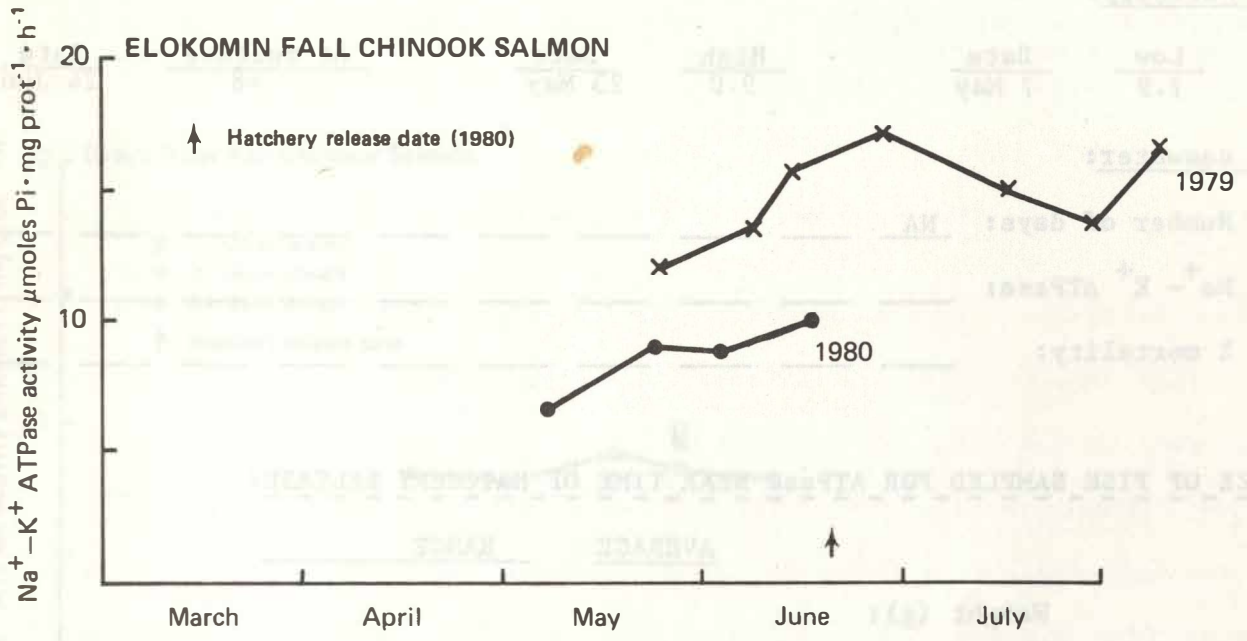

Figure A4.--Gill Na⁺-K⁺ ATPase activities in fall chinook salmon from the Elokomín Hatchery in 1979 and 1980.

SMOLT EVALUATION SUMMARY 9

HATCHERY: Grays River

SPECIES: Fall chinook STOCK: Grays River

DIET:

POND #: 4 to 11

RELEASE DATE: 24 June 1980

CODED WIRE TAG: 63-20-43

SUMMARY OF GILL $\text{Na}^+ - \text{K}^+$ ATPase ($\mu\text{moles P}_i \cdot \text{mg protein}^{-1} \cdot \text{hr}^{-1}$)

At hatchery:

<u>Low</u>	<u>Date</u>	<u>High</u>	<u>Date</u>	<u>At release</u>	<u>Date</u>
7.9	7 May	9.0	23 May	≈8	24 June

In seawater:

Number of days:	<u>NA</u>	_____	_____	_____	_____	_____
$\text{Na}^+ - \text{K}^+$ ATPase:	_____	_____	_____	_____	_____	_____
% mortality:	_____	_____	_____	_____	_____	_____

SIZE OF FISH SAMPLED FOR ATPase NEAR TIME OF HATCHERY RELEASE:

	<u>AVERAGE</u>	<u>RANGE</u>
Weight (g):	_____	_____
Fork length (mm):	80.0	62.0 - 94.0
Date:	17 June 1980	

TAGGED FISH CAPTURED AT JONES BEACH:

Date captured:	<u>No captures</u>	_____	_____	_____	_____
Number of fish:	_____	_____	_____	_____	_____
Mean fork length (mm):	_____	_____	_____	_____	_____
Mean $\text{Na}^+ - \text{K}^+$ ATPase:	_____	_____	_____	_____	_____
Mean Plasma T_3	_____	_____	_____	_____	_____
Mean Plasma T_4	_____	_____	_____	_____	_____

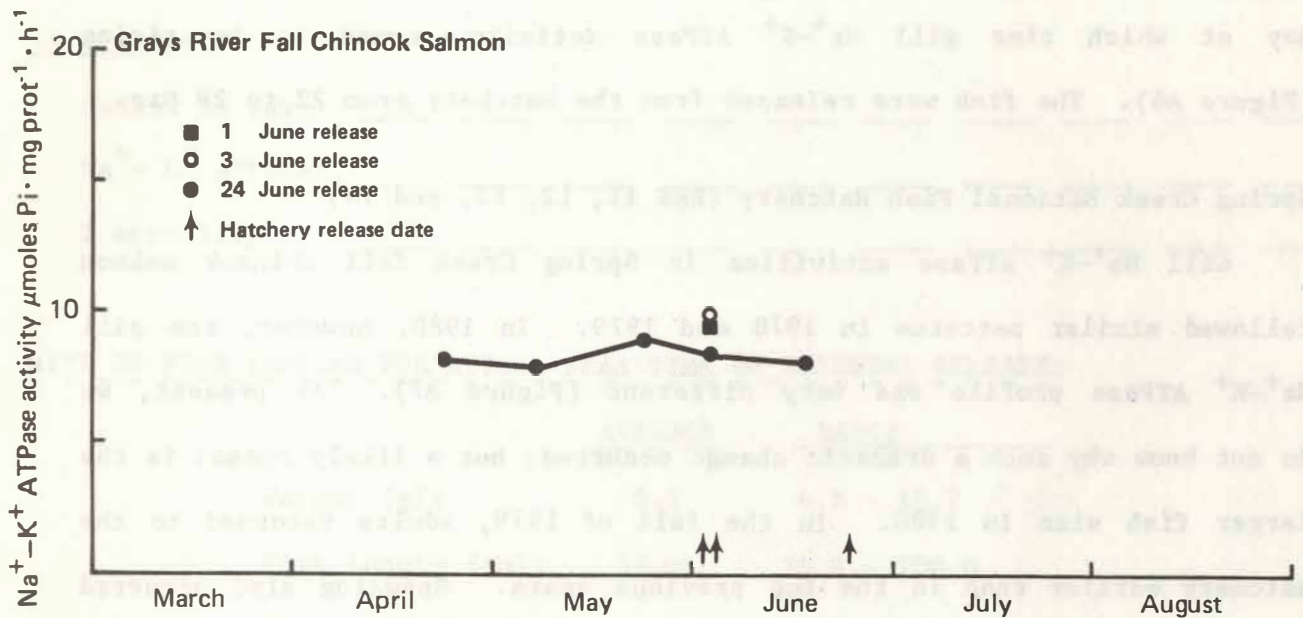

Figure A5.--Gill Na⁺-K⁺ ATPase activities in fall chinook salmon from the Grays River Hatchery in 1980.

(Figure A5). No recoveries of tagged fish were made at Jones Beach because of the location of the hatchery with respect to the recovery area.

Bonneville Hatchery (SES 10)

Fall chinook salmon from Pond D-3 were to be tagged and released for an evaluation study. However, because of severe disease problems, tagging was cancelled and gill $\text{Na}^+\text{-K}^+$ ATPase monitoring ceased after three samplings (Figure A6). Fish in Pond B-27 were sampled from 9 April to 28 May at which time gill $\text{Na}^+\text{-K}^+$ ATPase activity seemed to be rising (Figure A6). The fish were released from the hatchery from 22 to 28 May.

Spring Creek National Fish Hatchery (SES 11, 12, 13, and 14)

Gill $\text{Na}^+\text{-K}^+$ ATPase activities in Spring Creek fall chinook salmon followed similar patterns in 1978 and 1979. In 1980, however, the gill $\text{Na}^+\text{-K}^+$ ATPase profile was very different (Figure A7). At present, we do not know why such a dramatic change occurred, but a likely reason is the larger fish size in 1980. In the fall of 1979, adults returned to the hatchery earlier than in the two previous years. Spawning also occurred earlier and, consequently, release sizes were advanced by about 10 days, resulting in earlier releases. Fish released on 10 March had received a diet containing 7% added sodium chloride for about 4 weeks. The added salt resulted in some elevation of gill $\text{Na}^+\text{-K}^+$ ATPase activity compared to controls (Figure A7). When released on 10 March, the fish fed a salt supplemented diet migrated in a similar pattern to movements observed in 1978 and 1979. A comparison is made between the 1979 and 1980 migration pattern of fall chinook salmon in Figure A8. More of the fish moved down in the initial surge, reducing the bimodal pattern of past years. By the 17th day after release, 65% of the total number of marked fish captured

SMOLT EVALUATION SUMMARY 10

HATCHERY: Bonneville

SPECIES: Fall chinook STOCK: Bonneville

DIET:

POND #: B-27

RELEASE DATE: 22 to 28 May 1980

CODED WIRE TAG: 7-21-57

SUMMARY OF GILL Na⁺ - K⁺ ATPase (μmoles P_i · mg protein⁻¹ · hr⁻¹)

At hatchery:

<u>Low</u>	<u>Date</u>	<u>High</u>	<u>Date</u>	<u>At release</u>	<u>Date</u>
7.9	2 May	10.7	28 May	10.7	28 May

In seawater:

Number of days:	<u>NA</u>	_____	_____	_____	_____	_____
Na ⁺ - K ⁺ ATPase:	_____	_____	_____	_____	_____	_____
% mortality:	_____	_____	_____	_____	_____	_____

SIZE OF FISH SAMPLED FOR ATPase NEAR TIME OF HATCHERY RELEASE:

	<u>AVERAGE</u>	<u>RANGE</u>
Weight (g):	6.9	4.6 - 10.7
Fork length (mm):	87.0	75.0 - 100.0
Date:	28 May 1980	

TAGGED FISH CAPTURED AT JONES BEACH:

Date captured:	<u>24 May through 2 July</u>	_____	_____
Number of fish: (actual)	_____	_____	<u>55</u> total
Mean fork length (mm):	_____	_____	_____
Mean Na ⁺ - K ⁺ ATPase:	_____	_____	_____
Mean Plasma T ₃	_____	_____	_____
Mean Plasma T ₄	_____	_____	_____

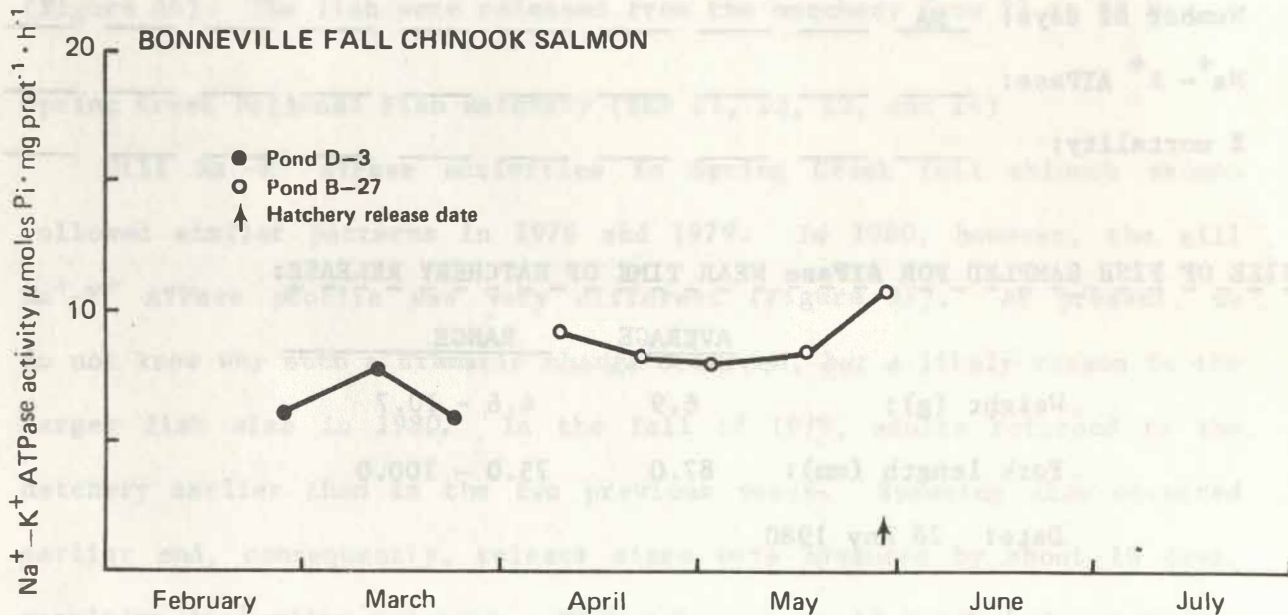

Figure A6.--Gill Na⁺-K⁺ ATPase activities in fall chinook salmon from the Bonneville Hatchery in 1980.

SMOLT EVALUATION SUMMARY 11

HATCHERY: Spring Creek SPECIES: Fall chinook STOCK: Spring Creek

DIET: Abernathy Dry^{a/} POND #: 20

RELEASE DATE: 10 March 1980 CODED WIRE TAG: 5-6-39

Number released: 130,208

SUMMARY OF GILL Na⁺ - K⁺ ATPase (μmoles P_i · mg protein⁻¹ · hr⁻¹)

At hatchery:

<u>Low</u>	<u>Date</u>	<u>High</u>	<u>Date</u>	<u>At release</u>	<u>Date</u>
12.4	11 Feb	18.2	10 Mar	18.2	10 Mar

In seawater:

Number of days: NA _____

Na⁺ - K⁺ ATPase: _____

% mortality: _____

SIZE OF FISH SAMPLED FOR ATPase NEAR TIME OF HATCHERY RELEASE:

	<u>AVERAGE</u>	<u>RANGE</u>
Weight (g):	4.3	3.1 - 5.1
Fork length (mm):	73.0	69.0 - 79.0
Date:		

TAGGED FISH CAPTURED AT JONES BEACH: (see Figure 8.)

Date captured: _____

Number of fish: _____

Mean fork length (mm): _____

Mean Na⁺ - K⁺ ATPase: _____

Mean Plasma T₃ _____

Mean Plasma T₄ _____

a/ Diet contained 7% added salt (NaCl) from 11 February to release.

SMOLT EVALUATION SUMMARY 12

HATCHERY: Spring Creek SPECIES: Fall chinook STOCK: Spring Creek
 DIET: Abernathy Dry POND #: 35
 RELEASE DATE: 10 April 1980 CODED WIRE TAG: 5-6-40
 Number released: 77,720

SUMMARY OF GILL Na⁺ - K⁺ ATPase ($\mu\text{moles P}_i \cdot \text{mg protein}^{-1} \cdot \text{hr}^{-1}$)

At hatchery:

<u>Low</u>	<u>Date</u>	<u>High</u>	<u>Date</u>	<u>At release</u>	<u>Date</u>
16.2	10 Apr	18.7	25 Mar	16.2	10 Apr

In seawater:

Number of days: NA

Na⁺ - K⁺ ATPase: _____

% mortality: _____

SIZE OF FISH SAMPLED FOR ATPase NEAR TIME OF HATCHERY RELEASE:

	<u>AVERAGE</u>	<u>RANGE</u>
Weight (g):	5.5	3.8 - 7.6
Fork length (mm):	80.0	74.0 - 90.0
Date: 10 April 1980		

TAGGED FISH CAPTURED AT JONES BEACH: (see Figure 8.)

Date captured: _____

Number of fish: _____

Mean fork length (mm): _____

Mean Na⁺ - K⁺ ATPase: _____

Mean Plasma T₃: _____

Mean Plasma T₄: _____

SMOLT EVALUATION SUMMARY 13

HATCHERY: Spring Creek SPECIES: Fall chinook STOCK: Spring Creek

DIET: Abernathy Dry POND #: 16

RELEASE DATE: 9 May 1980 CODED WIRE TAG: 5-6-41

Number released: 61,771

SUMMARY OF GILL $\text{Na}^+ - \text{K}^+$ ATPase ($\mu\text{moles P}_i \cdot \text{mg protein}^{-1} \cdot \text{hr}^{-1}$)

At hatchery:

<u>Low</u>	<u>Date</u>	<u>High</u>	<u>Date</u>	<u>At release</u>	<u>Date</u>
9.8	8 May	14.1	16 Apr	9.8	8 May

In seawater:

Number of days: NA _____

$\text{Na}^+ - \text{K}^+$ ATPase: _____

% mortality: _____

SIZE OF FISH SAMPLED FOR ATPase NEAR TIME OF HATCHERY RELEASE:

	<u>AVERAGE</u>	<u>RANGE</u>
Weight (g):		
Fork length (mm):	92.0	79.0 - 103.0
Date: 8 May 1980		

TAGGED FISH CAPTURED AT JONES BEACH: (see Figure 8.)

Date captured: _____

Number of fish: _____

Mean fork length (mm): _____

Mean $\text{Na}^+ - \text{K}^+$ ATPase: _____

Mean Plasma T_3 : _____

Mean Plasma T_4 : _____

SMOLT EVALUATION SUMMARY 14

HATCHERY: Spring Creek SPECIES: Fall chinook STOCK: Spring Creek
 DIET: Abernathy Dry POND #: 16 (from 22)
 RELEASE DATE: 7 August 1980 CODED WIRE TAG: 5-6-42
 Number released: 25,306

SUMMARY OF GILL $\text{Na}^+ - \text{K}^+$ ATPase ($\mu\text{moles P}_i \cdot \text{mg protein}^{-1} \cdot \text{hr}^{-1}$)

At hatchery:

<u>Low</u>	<u>Date</u>	<u>High</u>	<u>Date</u>	<u>At release</u>	<u>Date</u>
12.1	14 May	24.4	25 June	23.0	7 August

In seawater:

Number of days: NA _____
 $\text{Na}^+ - \text{K}^+$ ATPase: _____
 % mortality: _____

SIZE OF FISH SAMPLED FOR ATPase NEAR TIME OF HATCHERY RELEASE:

	<u>AVERAGE</u>	<u>RANGE</u>
Weight (g):	22.2	14.6-45.5
Fork length (mm):	126.0	113.0-147.0
Date:	7 August 1980	

TAGGED FISH CAPTURED AT JONES BEACH:

Date captured: _____
 Number of fish: _____
 Mean fork length (mm): _____
 Mean $\text{Na}^+ - \text{K}^+$ ATPase: _____
 Mean Plasma T_3 : _____
 Mean Plasma T_4 : _____

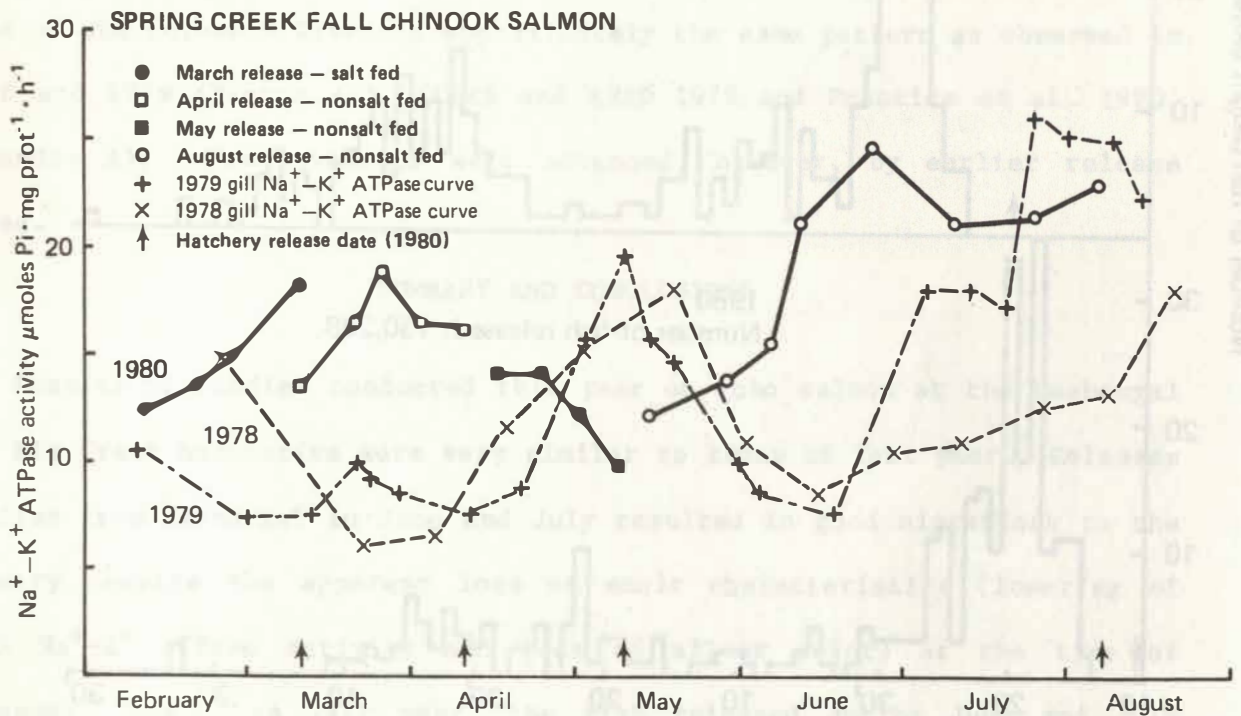

Figure A7.--Gill $\text{Na}^+ - \text{K}^+$ ATPase activities in fall chinook salmon from the Spring Creek NFH in 1980 compared to enzyme activities obtained in 1978 and 1979. Break in curve indicates sampling in new pond.

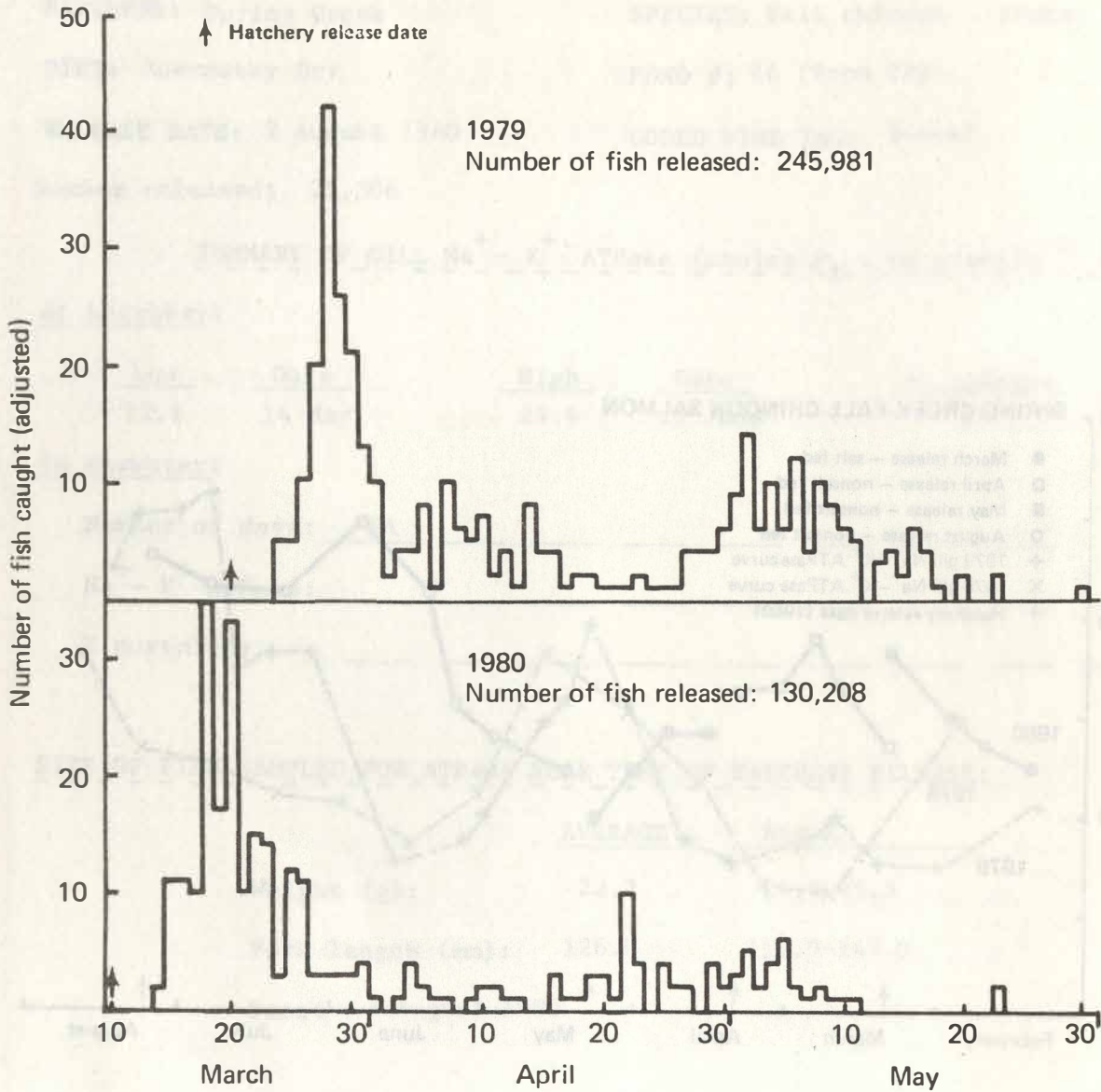

Figure A8.--Numbers of tagged migrants (adjusted) captured in the beach seine at Jones Beach from the March releases in 1979 and 1980 from the Spring Creek NFH. Adjusted number corrects total number of fish captured for fishing effort and efficiency.

from this group at Jones Beach had been caught. This compares to 47% for the same period in 1979. Whether the more rapid movement of a greater percentage of the fish resulted from a higher degree of smoltification at time of release cannot be stated with certainty, but it is suggested by higher levels of gill Na^+-K^+ ATPase activity. Also, salt feeding in 1980 introduced an uncontrolled variable.

Fish released in April, May, and August moved through the Jones Beach area of the Columbia River in approximately the same pattern as observed in 1978 and 1979 (Figure A9), (CZES and ETSD 1979 and Prentice et al. 1980, Appendix A). The movements were advanced, however, by earlier release dates.

SUMMARY AND CONCLUSIONS

Results of studies conducted this year on coho salmon at the Washougal and Big Creek hatcheries were very similar to those of last year. Releases of fish from Washougal in June and July resulted in good migrations to the estuary despite the apparent loss of smolt characteristics (lowering of gill Na^+-K^+ ATPase activity and loss of silver color) at the time of release. Again, as last year, the fish released during June and July showed rapid resmoltification once liberated from the hatchery. This resmoltification was evidenced by elevated gill Na^+-K^+ ATPase activities in migrants captured at Jones Beach and by the reappearance of visual changes normally associated with parr-smolt transformation.

This year, peak gill Na^+-K^+ ATPase activity in Big Creek coho salmon occurred 3 to 4 weeks later than last year (Figure A3), even though this year's fish were generally 2 to 3 g heavier. No explanation of the delay can be offered at this time.

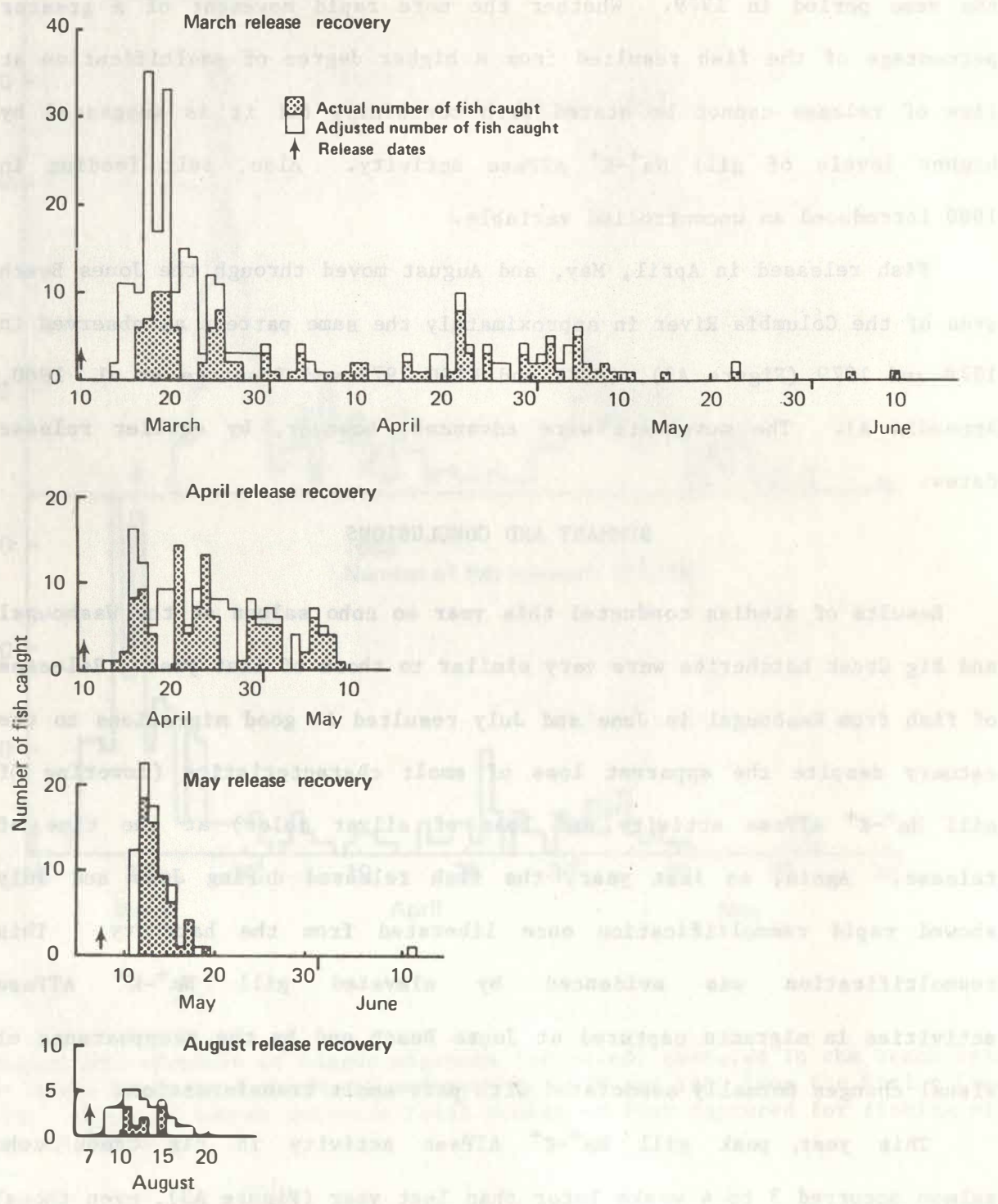

Figure A9.--Numbers of fall chinook salmon migrants (actual and adjusted) from the Spring Creek NFH captured at Jones Beach in 1980. Releases were made on 10 March, 10 April, 9 May, and 7 August. Adjusted number corrects total number of fish captured for fishing effort and efficiency.

Gill Na^+-K^+ ATPase activities were obtained for several groups of fall chinook salmon. Patterns obtained from groups of fish at Elokomín, Grays River, and Bonneville Hatcheries (Figures A4, A5, and A6) failed to show any dramatic changes during sampling periods. No migrants from Elokomín or Grays River Hatcheries were captured at Jones Beach because of its location upstream from the hatcheries. No biochemical information pertaining to smoltification was obtained from migrants liberated from Bonneville Hatchery and subsequently captured at Jones Beach.

The profile of gill Na^+-K^+ ATPase activities in Spring Creek fall chinook salmon was different this year than for the previous 2 years (Figure A7). Timing of migratory movements in the river, however, was not greatly different, though advanced by about 10 days because of earlier releases in 1980. Any correlations with survival must await adult returns. Feeding a diet containing 7% added NaCl for 4 weeks resulted in a significant elevation of gill Na^+-K^+ ATPase activity in fish of the March release (Figure A7). This same type of salt supplemented feeding trial was conducted in 1976 at Spring Creek NFH and resulted in a 50% greater contribution of adults over controls (Zaugg et al. in preparation).

REFERENCES

Coastal Zone and Estuarine Studies Division and Environmental and Technical Services Division.

1979. A study to assess status of smoltification and fitness for ocean survival of chinook, coho, and steelhead. Project 817.

Coastal Zone and Estuarine Studies Division, Northwest and Alaska Fisheries Center, 403 p. (Processed).

Dawley, E. M., C. W. Sims, R. D. Ledgerwood, D. R. Miller, and F. P. Thrower.

1980. A study to define the migration characteristics of chinook and coho salmon and steelhead in the Columbia River estuary. Project 10990061. Coastal Zone and Estuarine Studies Division, Northwest and Alaska Fisheries Center, 53 p. (Processed).

Prentice, E. F., C. Mahnken, K. Gores, W. Waknitz, L. Folmar, R. King, J. Mighell, W. Dickhoff, T. Flagg, L. Harrell, A. Novotny, D. Damkaer, E. Wold, and R. Vreeland.

1980. A study to assess status of smoltification and fitness for ocean survival of chinook and coho salmon and steelhead. Project 10990060. Coastal Zone and Estuarine Studies Division, Northwest and Alaska Fisheries Center, 408 p. (Processed).

Zaugg, W. S., and L. R. McLain.

1976. Influence of water temperature on gill sodium, potassium stimulated ATPase activity in juvenile coho salmon (Oncorhynchus kisutch). Comp. Biochem. Physiol. 54A:419-421.

Zaugg, W. S., E. F. Prentice, F. W. Waknitz, K. X. Gores, and D. D. Roley.
1980. Effect of dietary salt on salt water survival and contribution of chinook salmon (Oncorhynchus tshawytscha). Manuscript in preparation.

APPENDIX B

SELECTED PHYSIOLOGICAL CHANGES IN SALMON
DURING SMOLTIFICATION

by

Leroy Folmar

and

Walton Dickhoff

INTRODUCTION

In previous reports (CZES and ETSD 1979 and Prentice et al. 1980), we evaluated some physiological changes [gill $\text{Na}^+ - \text{K}^+$ ATPase activity; plasma thyroxine (T_4); triiodothyronine (T_3); and sodium, potassium, chloride, calcium, and magnesium ions] associated with smoltification in yearling coho and chinook salmon and steelhead trout from several Columbia River hatcheries. We also measured the same parameters during smoltification in subyearling and yearling coho salmon reared on an accelerated or non-accelerated growth regime, respectively, at the National Marine Fisheries Service, Northwest and Alaska Fisheries Center in Seattle.

Results of these studies suggest that measurement of thyroid hormones (T_4 and T_3) of fish in fresh water may be useful as an indicator of the course of smoltification and the appropriate time for transfer of coho salmon to seawater net-pens (Folmar and Dickhoff 1981). More specifically, the measurement of T_4 is useful in predicting survival of yearling coho in seawater, whereas, the measurement of T_3 appears useful for subyearlings (Dickhoff et al. 1981).

The current study concentrates on thyroid hormones during smoltification of yearling coho salmon. The levels of plasma T_4 were examined in fish in serial release programs at the Big Creek (Oregon Department of Fish and Wildlife) and Washougal (Washington Department of Fisheries) Hatcheries. These studies may provide useful information in determining the effects of size and time of release on the success of released fish in the marine environment.

METHODS AND MATERIALS

Yearling coho salmon were sampled at the Washougal and Big Creek Hatcheries. Fish at these hatcheries were separated into three groups each for release in May, June, and July. Feed schedules were adjusted so that the fish in all groups would be of similar size at the time of release. Blood samples were collected biweekly (30 fish from each test group) from March until the time of release. Blood was centrifuged and plasma was collected and frozen until assayed for thyroid hormone concentration. Hormones were assayed using a specific radioimmunoassay (Dickhoff et al. 1978).

RESULTS

The patterns of plasma T_4 of fish in the three release groups (May, June, July) at the Washougal hatchery are shown in Figure B1. Plasma T_4 in the May release group began increasing in mid-April, peaked by the first of May and then declined to basal levels by the release date in early May. The June and July groups showed elevations of T_4 during early April. The T_4 levels peaked in the June and July groups during mid- and late April, respectively. Plasma T_4 returned to basal levels in fish in the June release group by the beginning of May; T_4 remained low thereafter. The fish in the July group showed a secondary T_4 peak during May.

The patterns of plasma T_4 of fish in the three release groups at the Big Creek Hatchery are shown in Figure B2. Plasma T_4 of fish in the May group increased during late April and remained high throughout subsequent sampling times through the time of release in early May. The plasma hormone concentration of the June group showed two peaks, one in late March and one in late April. Plasma T_4 returned to basal levels by the time of

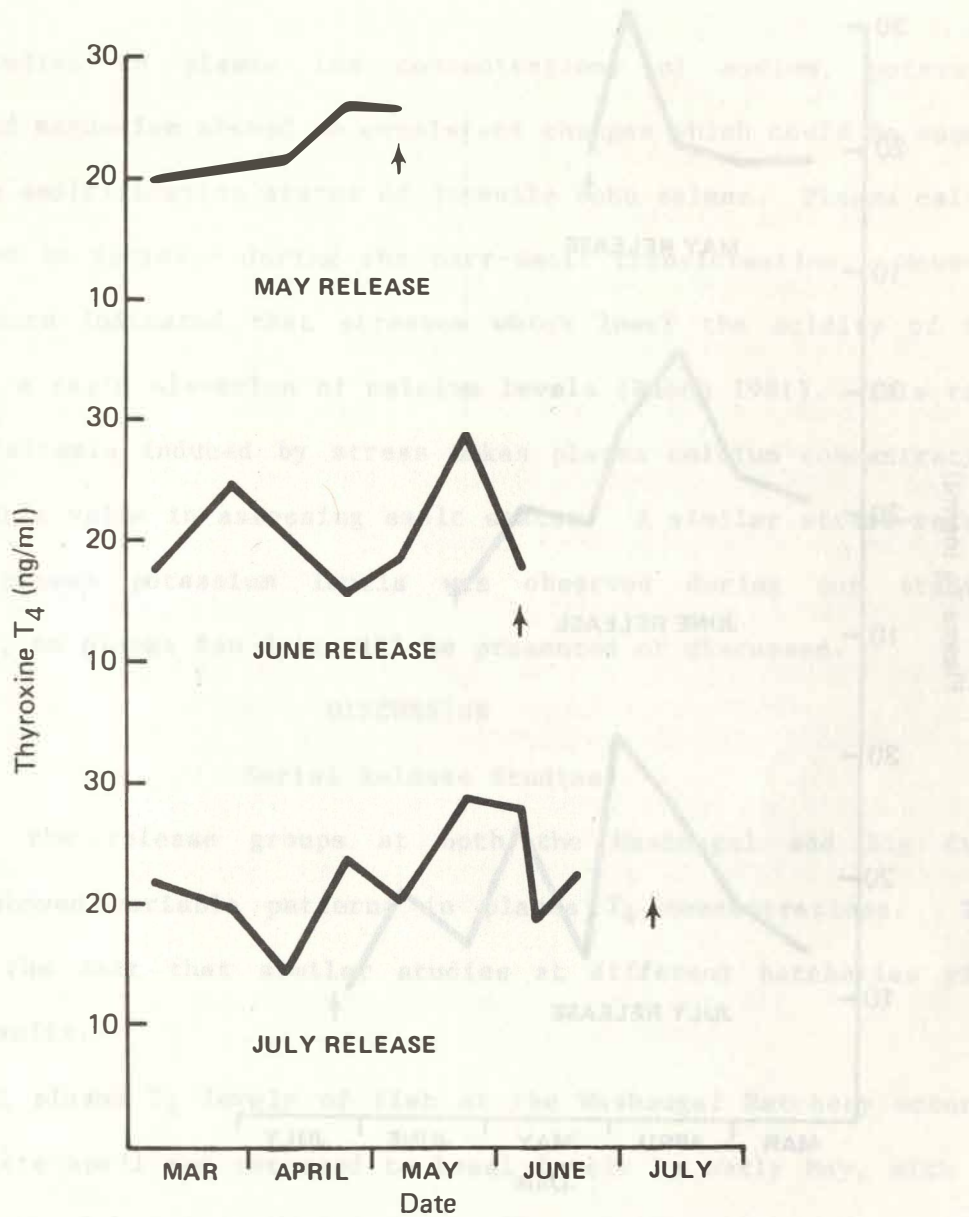

Figure B1.--Plasma T₄ concentrations vs time for yearling Washougal coho salmon during smoltification in fresh water. Arrows (↑) indicate time of release from hatchery.

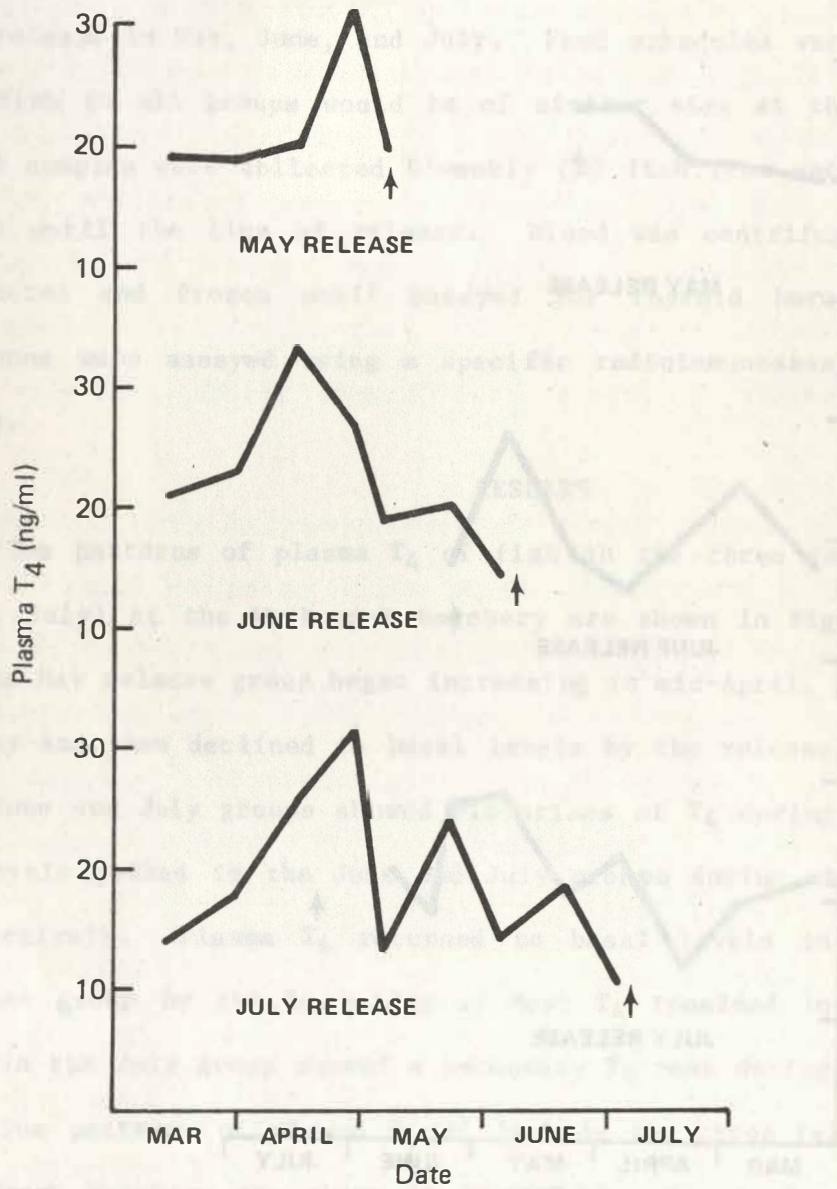

Figure B2.--Plasma T₄ concentrations vs time for yearling Big Creek coho salmon during smoltification in fresh water. Arrows (↑) indicate time of release from hatchery.

release in early June. Plasma T_4 in the July release fish showed a depression in early April followed by a peak during late May. Plasma T_4 in the July release group returned to near basal levels by the beginning of June.

The studies on plasma ion concentrations of sodium, potassium, chloride, and magnesium showed no consistent changes which could be used to evaluate the smoltification status of juvenile coho salmon. Plasma calcium levels showed an increase during the parr-smolt transformation. However, recent evidence indicated that stresses which lower the acidity of fish blood caused a rapid elevation of calcium levels (Ruben 1981). This rapid blood hypercalcemia induced by stress makes plasma calcium concentrations of questionable value in assessing smolt status. A similar stress-related effect on plasma potassium levels was observed during our studies. Consequently, no plasma ion data will be presented or discussed.

DISCUSSION

Serial Release Studies

All of the release groups at both the Washougal and Big Creek Hatcheries showed variable patterns in plasma T_4 concentrations. This illustrates the fact that similar studies at different hatcheries yield different results.

Highest plasma T_4 levels of fish at the Washougal Hatchery occurred by mid- to late April and returned to basal levels by early May, with the exception of the July group which had a small secondary peak in May. Based on our previous findings, which suggested that the fish are functionally smolted at the time the plasma T_4 returns to basal values, we can speculate on the probable significance of these patterns. The May release group was probably released at an appropriate time--soon after the decline

in plasma T_4 . Since the June and July groups were released quite late in relation to the T_4 cycle, we speculate that the performance of these groups may be poorer.

The patterns of the groups at the Big Creek Hatchery showed an early spring increase but no distinct peak for the May group; whereas, the T_4 peak of the June and July groups occurred in late May and returned to basal levels by the time of release. Using the basis for speculation mentioned previously, we predict that the May group was released too early for optimal seawater adaptation, the June group was released at an appropriate time, and the July group was released too late for optimal survival.

We must caution, however, that our basis for speculation was derived from studies in which fish were transferred directly from the hatchery to seawater net-pens. Many of the fish released from Columbia River hatcheries require 15-30 days to migrate to the estuary. This fact may alter the validity of our predictions.

REFERENCES

Coastal Zone and Estuarine Studies Division, and Environmental and Technical Services Division.

1979. A study to assess status of smoltification and fitness for ocean survival of chinook, coho, and steelhead. Project 817. Coastal Zone and Estuarine Studies Division, Northwest and Alaska Fisheries Center, 403 p. (Processed).

Dickhoff, W. W., L. C. Folmar, and A. Gorbman

1978. Changes in plasma thyroxine during smoltification of coho salmon, Oncorhynchus kisutch. Gen. Comp. Endocrinol. 36:229-232.

Dickhoff, W. W., L. C. Folmar, J. L. Mighell, C. V. W. Mahnken, and Gorbman, A.

1981. Thyroid hormones in smoltification of anadromous salmonids. Proc. North Pacific Aquaculture Symp., Newport, Oregon, August 26, 1980.

Folmar, L. C. and W. W. Dickhoff.

1981. Evaluation of some physiological parameters as predictive indices of smoltification. Aquaculture 22:309-324.

Prentice, E. F., C. Mahnken, K. Gores, W. Waknitz, L. Folmar, R. King, J. Mighell, W. Dickhoff, T. Flagg, L. Harrell, A. Novotny, D. Damkaer, E. Wold, and R. Vreeland.

1980. A study to assess status of smoltification and fitness for ocean survival of chinook and coho salmon and steelhead. Project 10990060. Coastal Zone and Estuarine Studies Division, Northwest and Alaska Fisheries Center, 408 p. (Processed).

Ruben, J. A.

1981. Exercise induced hypercalcemia in vertebrates. Proc. Western Reg. Conf. Comp. Endocrinol., Corvallis, Oregon.

APPENDIX C

SEAWATER ADAPTATION OF FALL CHINOOK SALMON

by

Earl F. Prentice

F. William Waknitz

and

Kurt X. Gores

INTRODUCTION

During the FY 1980 study, 11 groups of fall chinook salmon from 6 state and federal hatcheries were selected to be evaluated in seawater (Table C1, Figures C1 and C2). It was necessary to delete several test groups from the study, however, because of environmental and disease problems. In the final analysis, only six groups of fish from three hatcheries were evaluated. The objective was to determine seawater adaptation by monitoring growth, survival, disease, and parr-smolt transformation. In FY 1980, no coho salmon, spring chinook salmon, or steelhead were evaluated in seawater.

METHODS AND MATERIALS

The general methods and materials used in the study are discussed in CZES and ETSD (1979) and Prentice et al. (1980, Appendix B). In the present study, the following specific procedural changes were made:

(1) Since Prentice et al. (1980) concluded that a 30-day holding period in seawater was usually sufficient to determine seawater adaptability of fall chinook salmon, this time frame was adopted in 1980.

(2) Fish were not vaccinated against Vibrio anguillarum because of the short duration in seawater, and

(3) The day after a group of fish arrived (n = 300) at the Manchester Marine Experimental Station, the fish were weighed and measured (fork length); divided into two replicates (n = 150 per replicate); and then placed in troughs of running, aerated seawater. In past tests, large inventory discrepancies occurred when small fall chinook salmon were placed in net-pens for long periods (6 months). By placing the fish in troughs, mortalities were more closely monitored and inventory discrepancies were

Table C1r--Chinook and coho salmon test groups for 1980.

Hatchery	Stock	Species	Agency	Year	Reason for selection	Date of hatchery release	Date of seawater entry at Manchester	No. of fish repl.	No. of fish repl. 1	No. of fish repl. 2
Cascade	Sandy	Coho salmon	ODFW ^{a/}	1978	Serial release-size study	<u>d/</u>				
Cascade	Sandy	Coho salmon	ODFW	1978	Serial release-size study	<u>d/</u>				
Cascade	Sandy	Coho salmon	ODFW	1978	Serial release-size study	<u>d/</u>				
Toutle	Green River	Coho salmon	WDF ^{b/}	1978	Serial release-size study	5-07-80	<u>e/</u>			
Toutle	Green River	Coho salmon	WDF	1978	Serial release-size study	<u>d/</u>				
Toutle	Green River	Coho salmon	WDF	1978	Serial release-size study	<u>d/</u>				
Washougal	Cowlitz	Coho salmon	WDF	1978	Serial release-size study	5-08-80	<u>e/</u>			
Washougal	Cowlitz	Coho salmon	WDF	1978	Serial release-size study	6-09-80	<u>e/</u>			
Washougal	Cowlitz	Coho salmon	WDF	1978	Serial release-size study	7-07-80	<u>e/</u>			
Big Creek	Big Creek	Coho salmon	ODFW	1978	Serial release-size study	5-07-80	<u>e/</u>			
Big Creek	Big Creek	Coho salmon	ODFW	1978	Serial release-size study	6-06-80	<u>e/</u>			
Big Creek	Big Creek	Coho salmon	ODFW	1978	Serial release-size study	7-07-80	<u>e/</u>			
Green River	Green River	Coho salmon	WDF	1978	Density-size study	4-23-80	<u>e/</u>			
Green River	Green River	Coho salmon	WDF	1978	Density-size study	4-23-80	<u>e/</u>			
Green River	Green River	Coho salmon	WDF	1978	Density-size study	4-23-80	<u>e/</u>			
Green River	Green River	Coho salmon	WDF	1978	Density-size study	4-23-80	<u>e/</u>			
Green River	Green River	Coho salmon	WDF	1978	Density-size study	4-23-80	<u>e/</u>			
Green River	Green River	Coho salmon	WDF	1978	Density-size study	4-23-80	<u>e/</u>			
Green River	Green River	Coho salmon	WDF	1978	Density-size study	4-23-80	<u>e/</u>			
Green River	Green River	Coho salmon	WDF	1978	Density-size study	4-23-80	<u>e/</u>			
Spring Creek	Spring Creek	Fall chinook	USFWS ^{c/}	1979	Serial release study	3-10-80	3-12-80	2	150	150
Spring Creek	Spring Creek	Fall chinook	USFWS	1979	Serial release study	4-10-80	4-10-80	2	150	150
Spring Creek	Spring Creek	Fall chinook	USFWS	1979	Serial release study	5-09-80	5-13-80	2	150	150
Spring Creek	Spring Creek	Fall chinook	USFWS	1979	Serial release study	8-07-80	8-10-80	2	150	150
Bonneville	Bonneville	Fall chinook	ODFW	1979	Hatchery evaluation study	5-13-80	<u>e/</u>			
Bonneville	Bonneville	Fall chinook	ODFW	1979	Hatchery evaluation study	5/22-28/80	<u>e/</u>			
Bonneville	Bonneville	Fall chinook	ODFW	1979	Hatchery evaluation study	<u>d/</u>				
Toutle	Toutle	Fall chinook	WDF	1979	Hatchery evaluation study	<u>d/</u>				
Kalama Falls	Kalama Falls	Fall chinook	WDF	1979	Hatchery evaluation study	<u>d/</u>				
Elokomin	Elokomin	Fall chinook	WDF	1979	Hatchery evaluation study	6-19-80	6-23-80	2	150	150
Grays River	Grays River	Fall chinook	WDF	1979	Hatchery evaluation study	6-24-80	6-26-80	2	150	150

^{a/} Oregon Department of Fish and Wildlife^{b/} Washington Department of Fisheries^{c/} U.S. Fish and Wildlife Service^{d/} Study group eliminated^{e/} No seawater evaluation

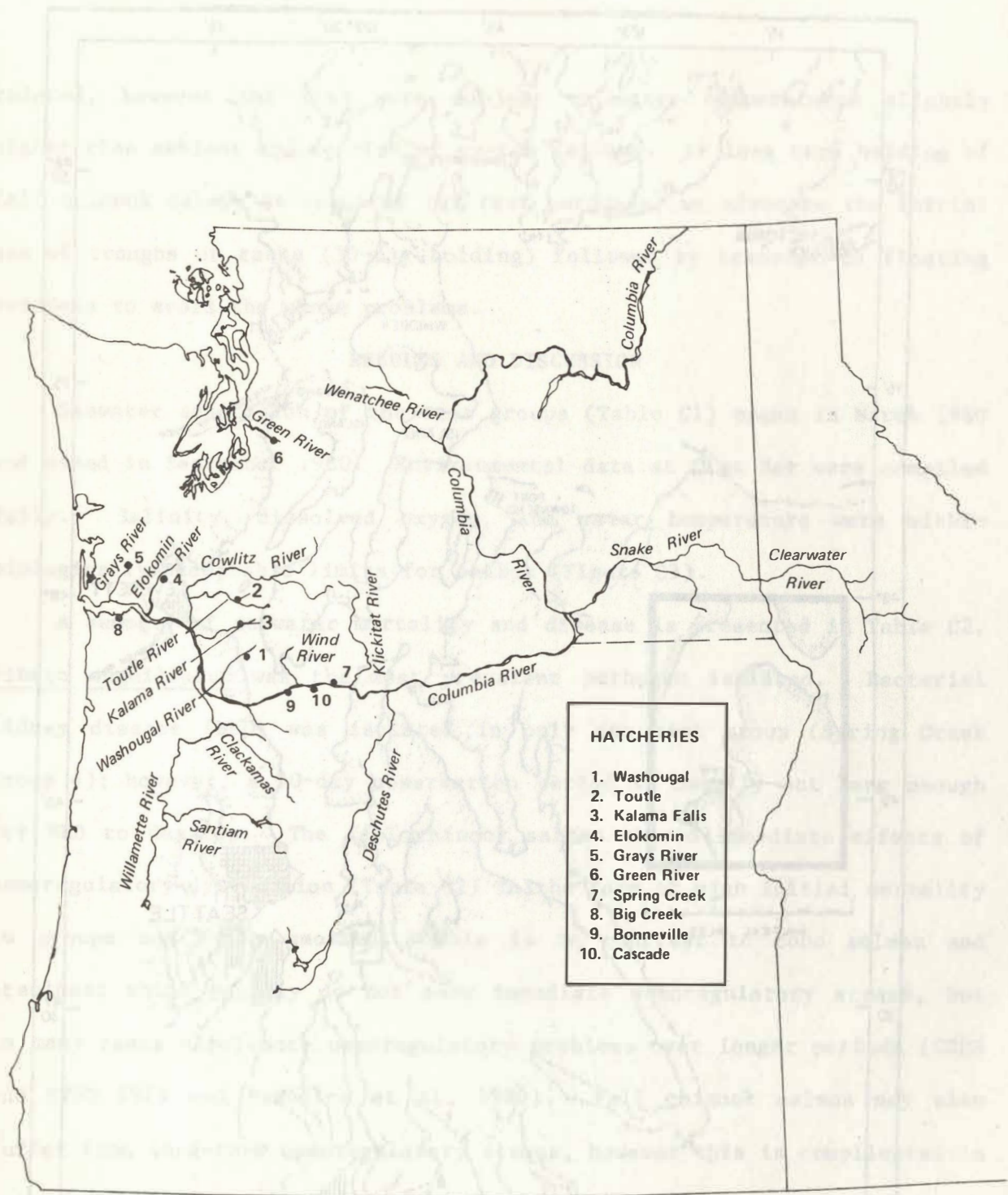

Figure C1.--Location of cooperating hatcheries.

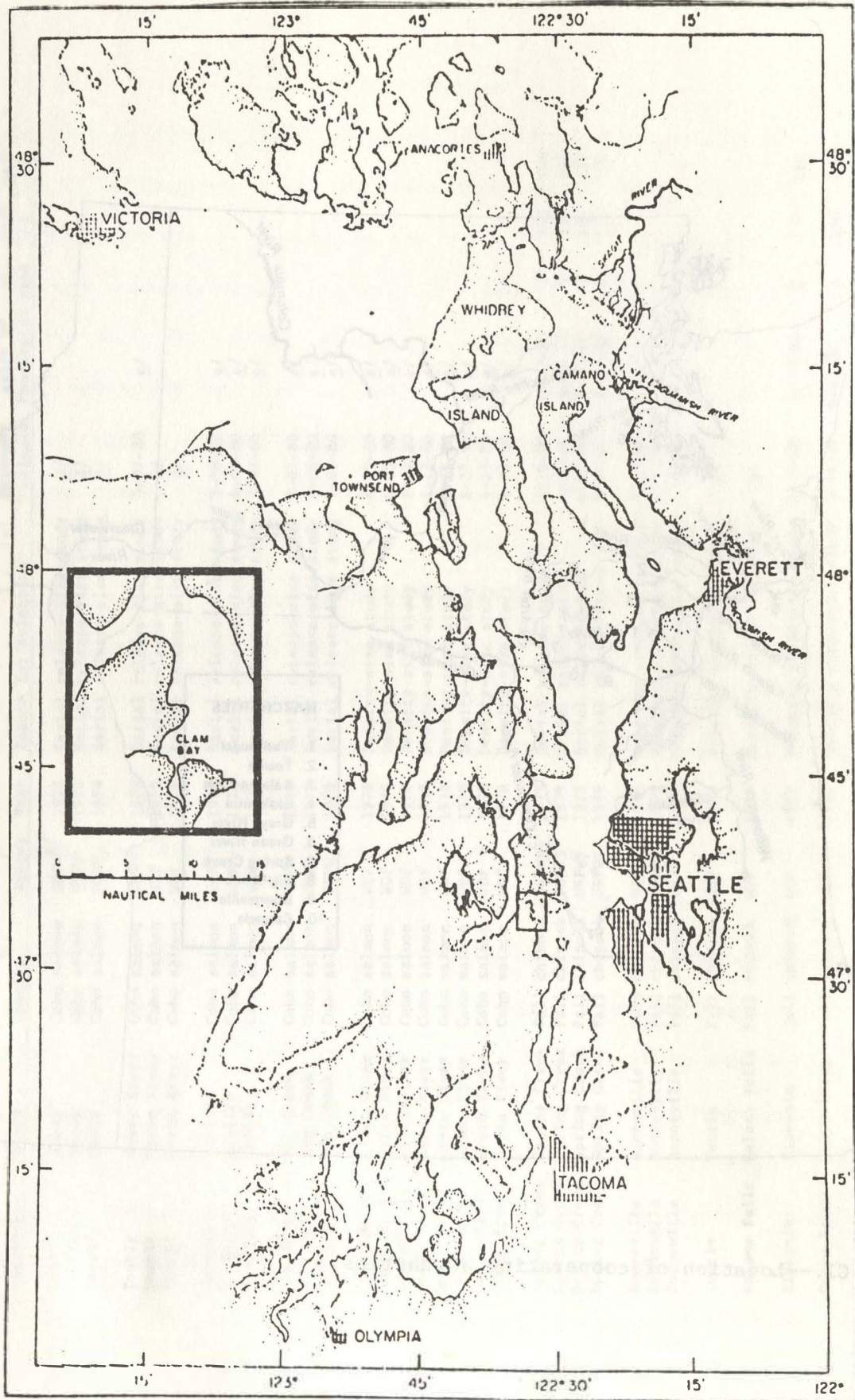

Figure C2.--Location of Manchester Marine Experimental Station on Clam Bay.

reduced, however the fish were subject to water temperatures slightly higher than ambient and to risk of system failure. If long term holding of fall chinook salmon is required for test purposes, we advocate the initial use of troughs or tanks (30-day holding) followed by transfer to floating net-pens to avoid the above problems.

RESULTS AND DISCUSSION

Seawater adaptation of the test groups (Table C1) began in March 1980 and ended in September 1980. Environmental data at Clam Bay were compiled daily. Salinity, dissolved oxygen, and water temperature were within biologically acceptable limits for salmon (Figure C3).

A summary of seawater mortality and disease is presented in Table C2. Vibrio anguillarum was the most prevalent pathogen isolated. Bacterial kidney disease (BKD) was isolated in only one test group (Spring Creek Group 4); however, a 30-day observation period is usually not long enough for BKD to develop. The fall chinook salmon showed immediate effects of osmoregulatory dysfunction (Table C2) in the form of high initial mortality in groups not fully smolted. This is in contrast to coho salmon and steelhead which usually do not show immediate osmoregulatory stress, but in many cases experience osmoregulatory problems over longer periods (CZES and ETSD 1979 and Prentice et al. 1980). Fall chinook salmon may also suffer from long-term osmoregulatory stress, however this is complicated in most cases by disease.

Seawater adaptability test results and discussion are presented by test group in a synopsis format. No comparisons are made between hatcheries or stocks as each group of fish is unique, except fish serially released from the same hatchery. Inventory discrepancies were found in

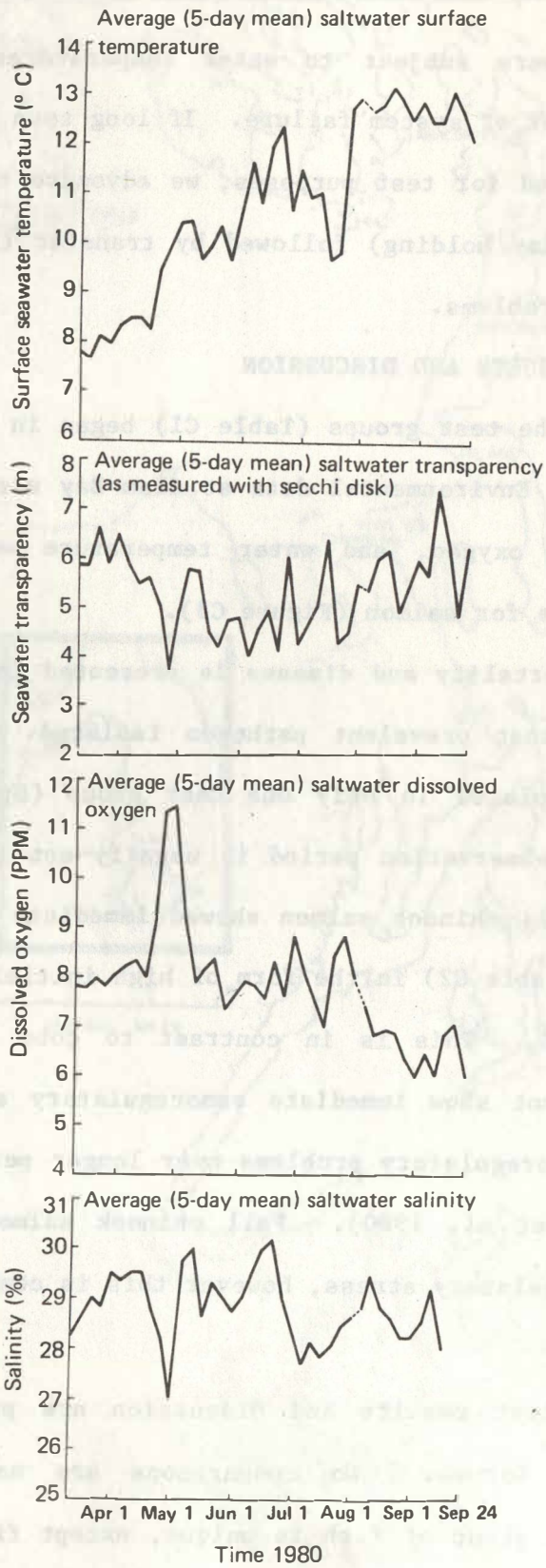

Figure C3.--Environmental data at Clam Bay, Washington.

Table C2.--Inventory and seawater disease record of fall chinook salmon test groups.

INVENTORY RECORD

Test group	No. fish at start of study	No. fish at termination & % survival		Total loss of fish (No.)	Total re-covered mortalities (No.)	Total unre-covered mortalities		Recovered mortalities not examined (decomposed)		Recovered mortalities examined	
		(No.)	(%)			(No.)	(%)	(No.)	(%)	(No.)	(%)
<u>Fall Chinook</u>											
Spring Creek (Group 1)	300	266	88.7	34	32	2	0.7	12	4.0	20	6.7
Spring Creek (Group 2)	300	205	68.3	95	93	2	0.7	31	10.3	62	20.7
Spring Creek (Group 3)	300	15	5.0	285	281	4	1.3	171	57.0	110	36.7
Elokomin	300	40	13.3	260	249	11	3.7	123	41.0	126	42.0
Grays River	300	14	4.7	286	282	4	1.3	208	69.3	74	24.7
Spring Creek (Group 4)	300	187	62.3	113	95	18	6.0	86	28.7	9	3.0

PATHOLOGIST'S DIAGNOSIS OF MORTALITIES IN SEAWATER

	Nega-tive	BKD ^{a/}	<u>Vibrio</u> ^{b/} spp.	ERM ^{c/}	<u>Aero</u> ^{d/} <u>liq</u>	Osmo ^{e/} dys	Furun ^{f/}
<u>Fall Chinook</u>							
Spring Creek (Group 1)	0	0	0	0	0	20	0
Spring Creek (Group 2)	7	0	12	0	0	43	0
Spring Creek (Group 3)	5	0	59	0	0	46	0
Elokomin	1	0	22	0	0	103	0
Grays River	0	0	25	0	0	49	0
Spring Creek (Group 4)	1	1	7	0	0	0	0

- a/ Bacterial Kidney Disease
- b/ Vibrio anguillarum strains 775, 1669, 7244
- c/ Enteric Red Mouth
- d/ Aeromonas liquefaciens
- e/ Osmoregulatory dysfunction
- f/ Furunculosis

most test groups. The unaccountable increases or decreases of fish ranged from 0.7 to 6.0% (Table C2). The discrepancies were attributed to dead fish that were not removed, fish jumping out of holding containers, and miscounts. Environmental data are based on 5-day means (Figure C3); environmental observations shown on the synopsis forms are for the specific date of seawater entry.

It must be emphasized that the test conditions differ from those found in the natural environment in several important respects: (1) no gradual salinity gradient similar to the Columbia River estuary is available to the test groups at Manchester; (2) in the river, fish are capable of smolting while actively outmigrating; and (3) the transfer of the test groups to Manchester imposed conditions not normally encountered by fish released from hatcheries. Among these conditions are physical stresses associated with transportation; confinement; handling; measuring; and, most importantly, direct transfer to seawater. However, except for exposure to changing environmental conditions that vary with time of seawater entry, all test groups received the same treatment. Therefore, data for the 1980 experimental period do not represent actual performance of the test groups in their normal environmental and geographic range, but only reflect performance under the test conditions in seawater at Manchester.

TEST GROUP SYNOPSIS

Hatchery: Spring Creek Species: Fall Chinook Stock: Spring Creek
Group (1)
Date of Initial Observation: 03-11-80 Termination Date: 04-14-80 Elapsed Days: 34

Number of Replicates: 2 Total No. of Fish at Start: 300
Total No. of Fish at Termination: 266

Surface Water Temperature at Time of Seawater entry: 7.8°C Figure: C3
Surface Salinity at Time of Seawater Entry: 29.0 ‰ Figure: C3
Dissolved Oxygen at Time of Seawater Entry: 7.86 ppm Figure: C3
Water Transparency (Secchi Disc) at Time of Seawater Entry (m): 7.8 Figure: C3

SALTWATER ADAPTATION

Status of smoltification at time of entry and at termination based on external characteristics:

	n		%		\bar{X} (Wt) (g)		\bar{X} (L) (mm)	
	Start	End	Start	End	Start	End	Start	End
Parr	243	69	81.0	25.9	3.7	3.0	69.7	68.1
Transitional	55	176	18.3	66.2	4.8	4.0	75.9	73.8
Smolt	2	21	0.7	7.9	4.1	4.9	72.5	78.9
Precocious	0	0	--	--	--	--	--	--
Population	300	266	100.0	100.0	3.9	3.8	70.9	72.8

Seawater Inventory, Disease, Measurement, and Visual Observation Data:

Table(s): C2 and C3

Figure(s): C4

OVERALL SEAWATER ADAPTATION
OF SPRING CREEK FALL CHINOOK SALMON (GROUP 1)

COMMENTS

When introduced to seawater, 81% of this test group was visually characterized as parr, over 18% as transitional, and less than 1% as smolt. Mean size was 3.9 g. At termination of testing (34 days), the incidence of parred fish had decreased to almost 25%, whereas, transitional and smolt stage fish increased to 66% and 8% respectively, indicating a progressive trend toward full seawater adaptability.

The total survival was better than 88% with less than 7% of the losses attributed to osmoregulatory dysfunction. No mortalities due to vibriosis were recorded in this test group.

SPRING CREEK FALL CHINOOK (Group 1)

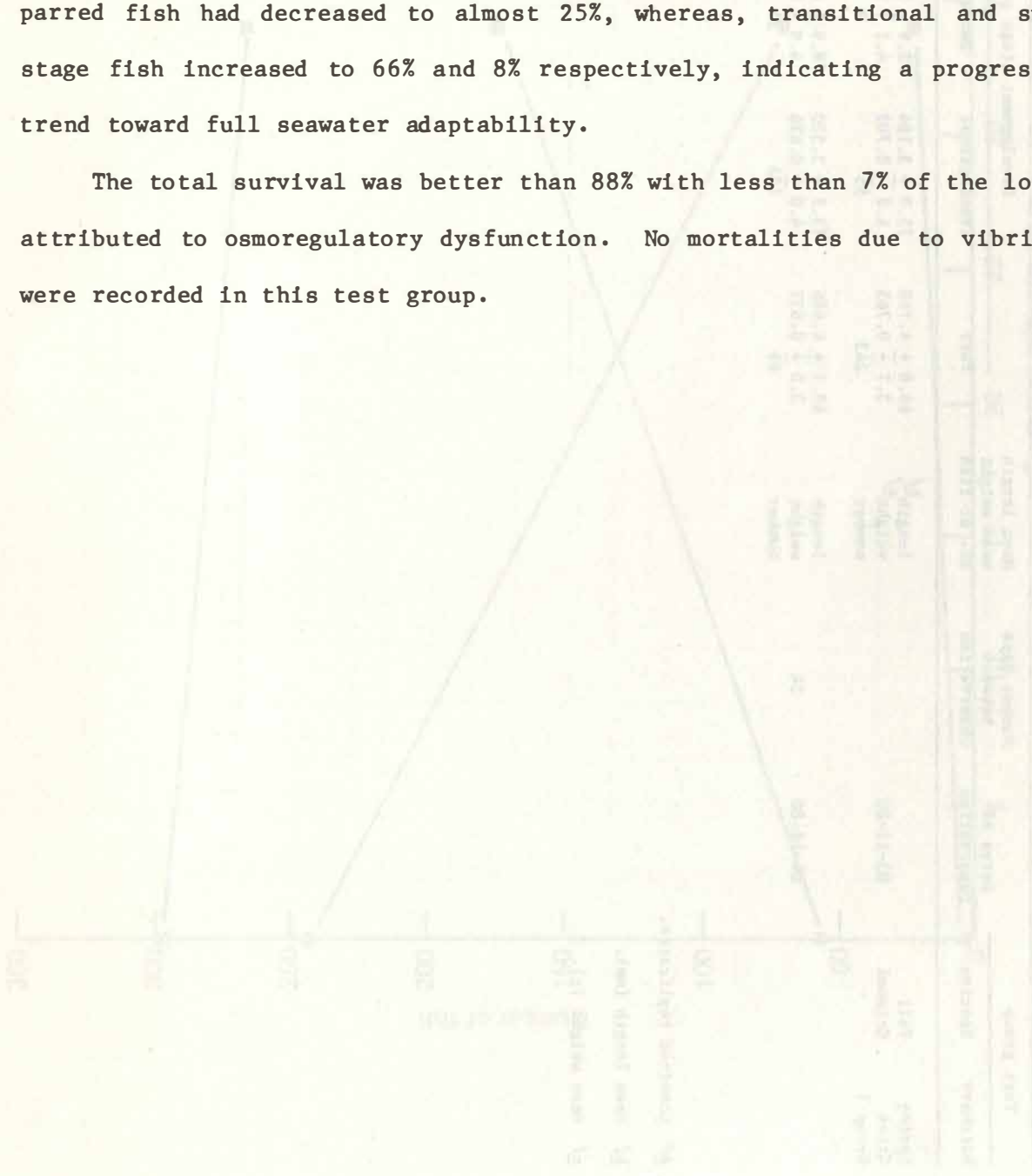

Table C3.--Length and weight of fish during different stages of development in seawater.^{a/}

Test group		Dates of observation	Number days between observation	Mean length mean weight no. of fish	Development stage of fish in test group				Total test group
Hatchery	Species				Parr	Transitional	Smolt	Precocious	
Spring Creek Group 1	Fall Chinook	03-11-80		length ^{b/}	69.8 ± 4.788	75.9 ± 3.184	72.9 ± 2.121	-	70.9 ± 5.106
				weight ^{c/}	3.7 ± 0.765	4.8 ± 0.702	4.1 ± 0.424	-	3.9 ± 0.856
				number	243	55	2	0	300
		04-14-80	34	length	68.1 ± 4.686	73.8 ± 3.520	78.9 ± 4.163	-	72.8 ± 4.947
				weight	3.0 ± 0.632	4.0 ± 0.676	4.9 ± 0.916	-	3.8 ± 0.881
				number	69	176	21	0	266

^{a/} Combined replicates.

^{b/} Mean length (mm).

^{c/} Mean weight (g).

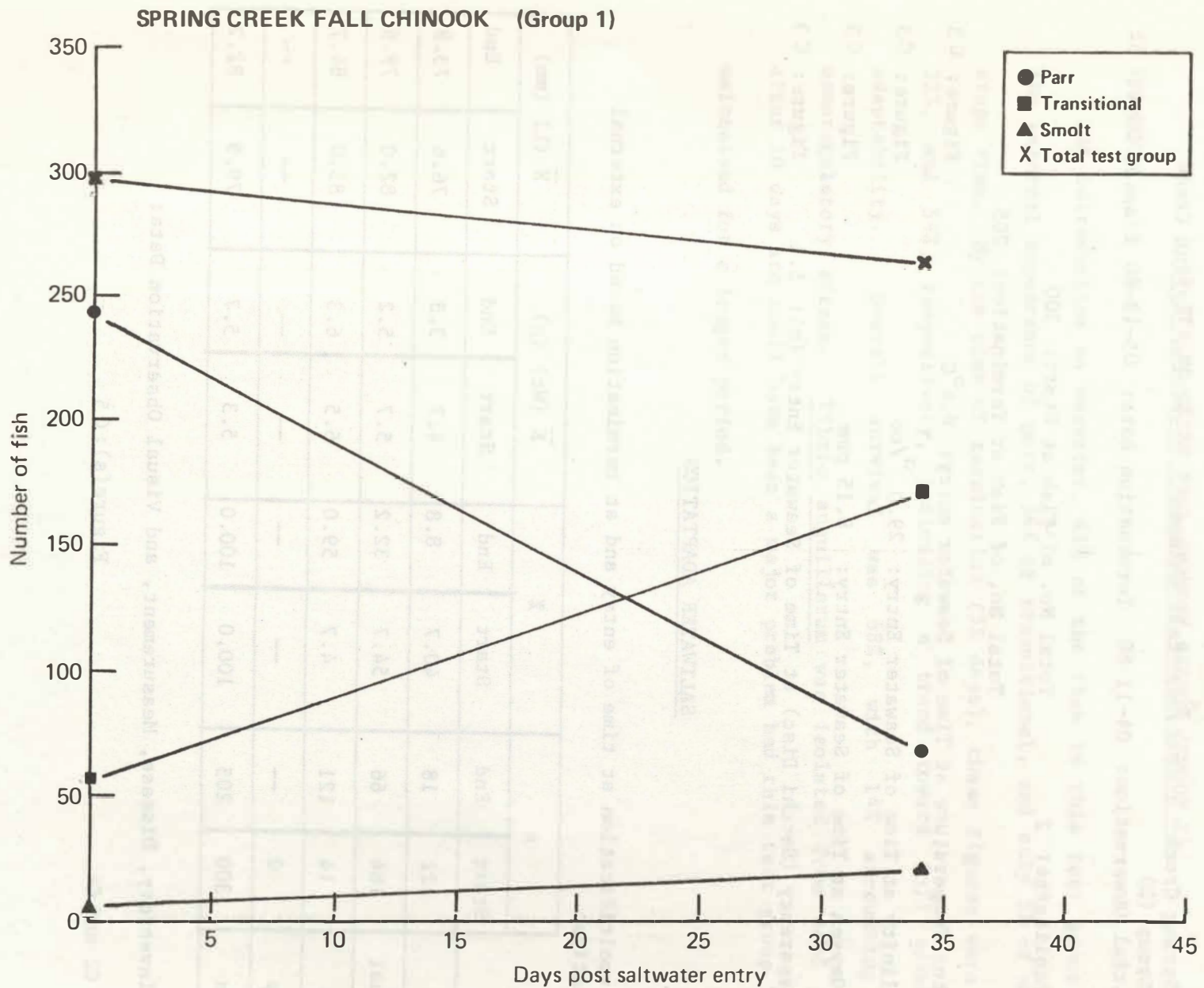

Figure C4.--Number of parred, transitional, and smolted fish (staging based on external characteristics) and total test group survival in seawater vs time.

TEST GROUP SYNOPSIS

Hatchery: Spring Creek Species: Fall Chinook Stock: Spring Creek
Group (2)
Date of Initial Observation: 04-11-80 Termination Date: 05-13-80 Elapsed Days: 32

Number of Replicates: 2 Total No. of Fish at Start: 300
Total No. of Fish at Termination: 205

Surface Water Temperature at Time of Seawater entry: 8.4°C Figure: C 3
Surface Salinity at Time of Seawater Entry: 29.0 ‰ Figure: C 3
Dissolved Oxygen at Time of Seawater Entry: 8.15 ppm Figure: C 3
Water Transparency (Secchi Disc) at Time of Seawater Entry (m): 5.1 Figure: C 3

SALTWATER ADAPTATION

Status of smoltification at time of entry and at termination based on external characteristics:

	n		%		\bar{X} (Wt) (g)		\bar{X} (L) (mm)	
	Start	End	Start	End	Start	End	Start	End
Parr	122	18	40.7	8.8	4.7	3.8	76.6	73.8
Transitional	164	66	54.7	32.2	5.7	5.2	82.0	79.9
Smolt	14	121	4.7	59.0	6.5	6.3	85.0	84.7
Precocious	0	--	--	--	--	--	--	--
Population	300	205	100.0	100.0	5.3	5.7	79.9	82.2

Seawater Inventory, Disease, Measurement, and Visual Observation Data:

Table(s): C2 and C4 Figure(s): C 5

OVERALL SEAWATER ADAPTATION

OF SPRING CREEK FALL CHINOOK SALMON (GROUP 2)

COMMENTS

At introduction to seawater, 41% of the fish in this test group had the external appearance of parr, 54% of transitional, and only 5% of smolt stage fish. By the time of termination (32 days), these figures were 9%, 32%, and 59%, respectively, indicating a trend toward full seawater adaptability. Overall survival was 68%, with 14% succumbing to osmoregulatory stress. Vibrio anguillarum was isolated from dead fish after 10 days and would have been a major problem had this test group been maintained for a longer period.

Table C4.--Length and weight of fish during different stages of development in seawater.^{a/}

Test group		Dates of observation	Number days between observation	Mean length mean weight no. of fish	Development stage of fish in test group				Total test group
Hatchery	Species				Parr	Transitional	Smolt	Precocious	
Spring Creek Group 2	Fall Chinook	04-11-80		length ^{b/} weight ^{c/} number 76.6 ± 4.931 4.7 ± 0.944 122	76.6 ± 4.931 4.7 ± 0.944 122	82.0 ± 3.536 5.7 ± 0.800 164	85.0 ± 2.512 6.5 ± 0.819 14	- - 0	79.9 ± 5.018 5.3 ± 1.031 300
		05-13-80	32	length weight number 73.8 ± 3.148 3.8 ± 0.723 18	73.8 ± 3.148 3.8 ± 0.723 18	79.9 ± 3.905 5.2 ± 0.991 66	84.7 ± 4.525 6.3 ± 1.263 121	- - 0	82.2 ± 5.410 5.7 ± 1.393 205

a/ Combined replicates.

b/ Mean length (mm).

c/ Mean weight (g).

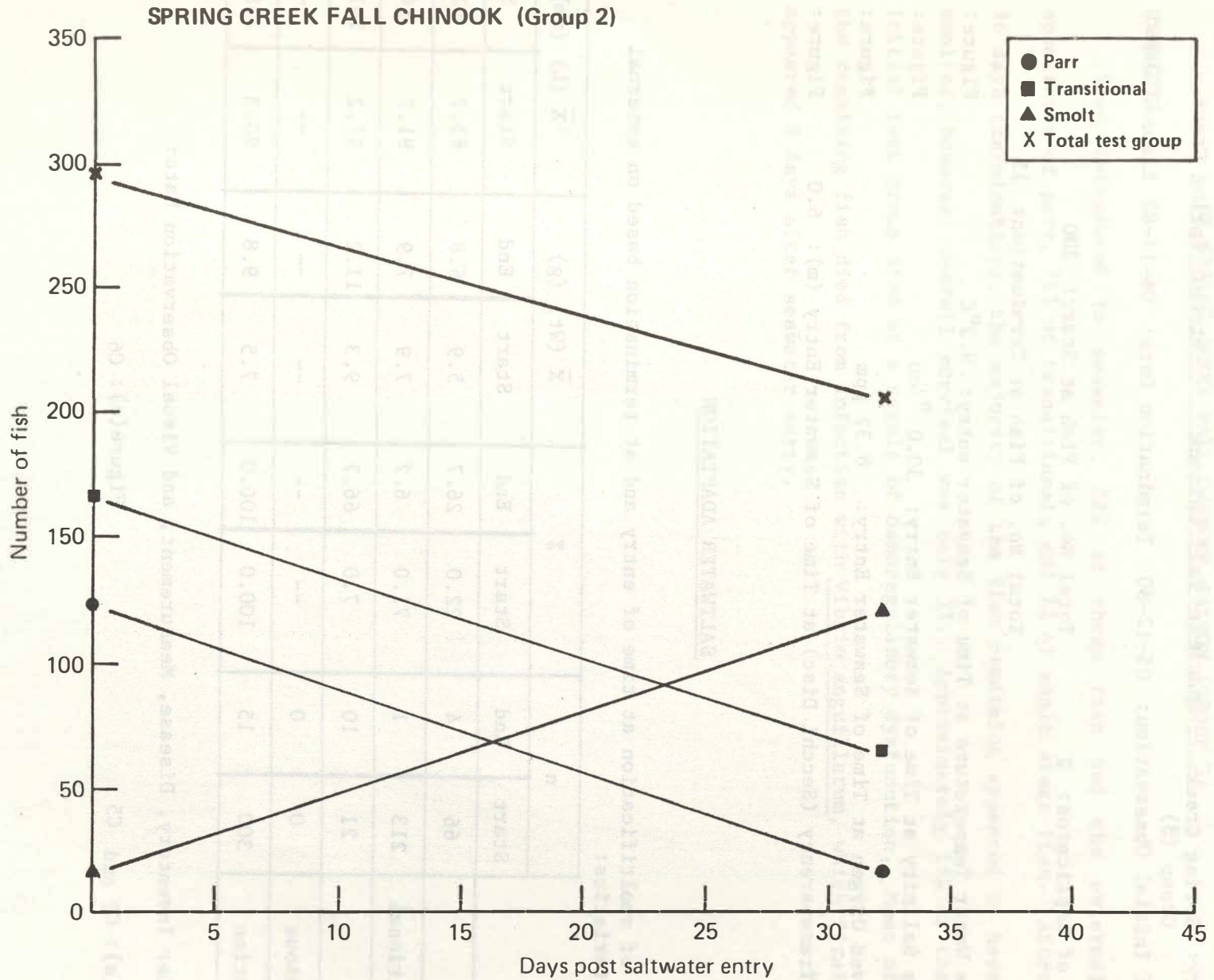

Figure C5.--Number of parred, transitional, and smolted fish (staging based on external characteristics) and total test group survival in seawater vs time.

TEST GROUP SYNOPSIS

Hatchery: Spring Creek Species: Fall Chinook Stock: Spring Creek
Group (3)
Date of Initial Observation: 05-12-80 Termination Date: 06-17-80 Elapsed Days: 36

Number of Replicates: 2 Total No. of Fish at Start: 300
Total No. of Fish at Termination: 15

Surface Water Temperature at Time of Seawater entry: 9.2°C Figure: C3
Surface Salinity at Time of Seawater Entry: 30.0 ‰ Figure: C3
Dissolved Oxygen at Time of Seawater Entry: 8.32 ppm Figure: C3
Water Transparency (Secchi Disc) at Time of Seawater Entry (m): 6.0 Figure: C3

SALTWATER ADAPTATION

Status of smoltification at time of entry and at termination based on external characteristics:

	n		%		\bar{X} (Wt) (g)		\bar{X} (L) (mm)	
	Start	End	Start	End	Start	End	Start	End
Parr	66	4	22.0	26.7	5.9	6.8	83.7	92.0
Transitional	213	1	71.0	6.7	7.9	7.9	91.7	94.0
Smolt	21	10	7.0	66.7	9.3	11.2	97.2	101.1
Precocious	0	0	--	--	--	--	--	--
Population	300	15	100.0	100.0	7.5	9.8	90.3	98.2

Seawater Inventory, Disease, Measurement, and Visual Observation Data:

Table(s): C2 and C5

Figure(s): C6

OVERALL SEAWATER ADAPTATION
OF SPRING CREEK FALL CHINOOK SALMON (GROUP 3)

COMMENTS

When introduced to seawater, 22% of these fish had the external appearance of parr, 71% of transitional, and 7% of smolt stage fish. After 36 days (termination), the majority of the fish remaining appeared to have smolted, however, overall survival was only 5%. Approximately 15% of the initial test group died as a result of osmoregulatory dysfunction. Most of the remaining fish died from infection with Vibrio anguillarum, which first appeared 8 days after seawater entry.



Table C5.--Length and weight of fish during different stages of development in seawater.^{a/}

Test group		Dates of observation	Number days between observation	Mean length mean weight no. of fish	Development stage of fish in test group				Total test group
Hatchery	Species				Parr	Transitional	Smolt	Precocious	
Spring Creek Group 3	Fall Chinook	05-12-80		length ^{b/}	83.7 ± 5.838	91.7 ± 4.327	97.2 ± 3.586	-	90.3 ± 5.987
				weight ^{c/}	5.9 ± 1.209	7.9 ± 1.152	9.3 ± 1.128	-	7.5 ± 1.494
				number	66	213	21	0	300
		06-17-80	31	length	92.0 ± 5.715	94.0 ± 0.000	101.1 ± 4.909	-	98.2 ± 6.383
				weight	6.8 ± 1.577	7.9 ± 0.000	11.2 ± 2.638	-	9.8 ± 2.900
				number	4	1	10	0	15

a/ Combined replicates.

b/ Mean length (mm).

c/ Mean weight (g).

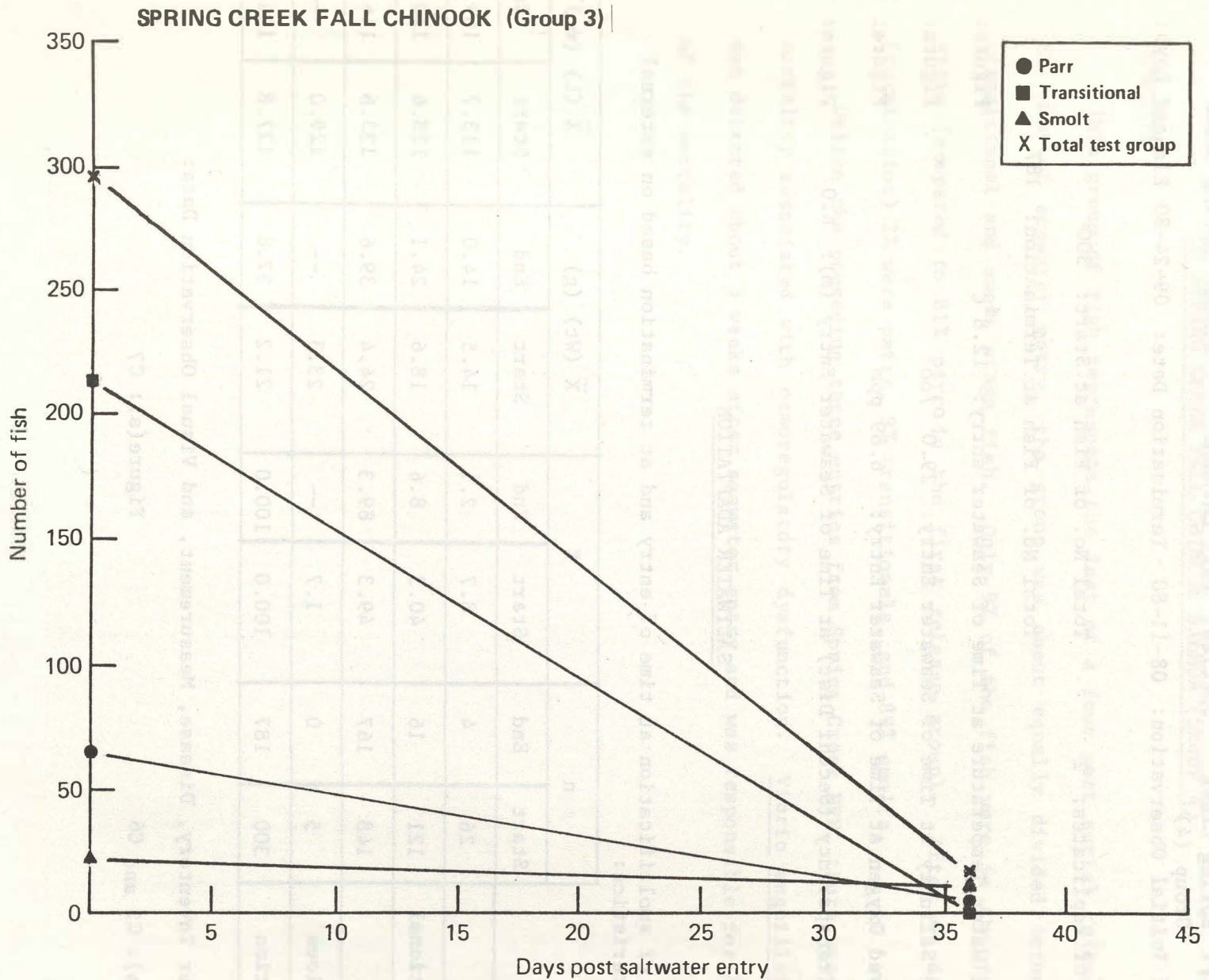

Figure C6.--Number of parred, transitional, and smolted fish (staging based on external characteristics) and total test group survival in seawater vs time.

TEST GROUP SYNOPSIS

Hatchery: Spring Creek Species: Fall Chinook Stock: Spring Creek
Group (4)
Date of Initial Observation: 08-11-80 Termination Date: 09-24-80 Elapsed Days: 44

Number of Replicates: 2 Total No. of Fish at Start: 300
Total No. of Fish at Termination: 187

Surface Water Temperature at Time of Seawater entry: 12.8°C Figure: C3
Surface Salinity at Time of Seawater Entry: 29.0 ‰ Figure: C3
Dissolved Oxygen at Time of Seawater Entry: 6.89 ppm Figure: C3
Water Transparency (Secchi Disc) at Time of Seawater Entry (m): 6.0 Figure: C3

SALTWATER ADAPTATION

Status of smoltification at time of entry and at termination based on external characteristics:

	n		%		\bar{X} (Wt) (g)		\bar{X} (L) (mm)	
	Start	End	Start	End	Start	End	Start	End
Parr	26	4	8.7	2.1	14.5	14.0	113.7	109.2
Transitional	121	16	40.3	8.6	18.6	24.1	123.6	130.6
Smolt	148	167	49.3	89.3	24.4	39.6	133.6	146.7
Precocious	5	0	1.7	--	23.3	--	129.0	--
Population	300	187	100.0	100.0	21.2	37.8	127.8	144.5

Seawater Inventory, Disease, Measurement, and Visual Observation Data:

Table(s): C2 and C6

Figure(s): C7

OVERALL SEAWATER ADAPTATION
OF SPRING CREEK FALL CHINOOK SALMON (GROUP 4)

COMMENTS

This group of fish represents the last of a four part serial release. At time of seawater entry, the group was about equally divided between transitional and smolt stage fish. Only 9% of the fish were in the parr stage (compared to 81% parr in the first release group). After 44 days (termination) 2% were parrs, 9% transitionals, and 89% smolts.

Unlike the preceding three entries from Spring Creek NFH, there was no mortality associated with osmoregulatory dysfunction. Vibrio anguillarum was detected about 3 weeks after seawater entry and was responsible for 78% of the mortality.

Table C6.--Length and weight of fish during different stages of development in seawater.^{a/}

Hatchery	Test Group		Number days between observation	Mean length mean weight no. of fish	Developmental stage of fish in test group				Total test group
	Species	Days of observation			Parr	Transitional	Smolt	Precocious	
Spring Creek (Group 4)	Fall Chinook	08/11/80		Length ^{b/} Weight ^{c/} Number	113.7 ± 6.428 14.5 ± 2.809 26	123.6 ± 5.340 18.6 ± 2.669 121	133.6 ± 6.822 24.4 ± 4.371 148	129.0 ± 5.339 23.3 ± 2.969 5	127.8 ± 8.905 21.2 ± 4.985 300
		09/24/80	44	Length Weight Number	109.2 ± 5.124 14.0 ± 2.365 4	130.6 ± 5.465 24.1 ± 3.683 16	146.7 ± 10.336 39.6 ± 10.298 167	0	144.5 ± 12.085 37.8 ± 11.273 187

a/ Combined replicates

b/ Mean length (mm)

c/ Mean Weight (g)

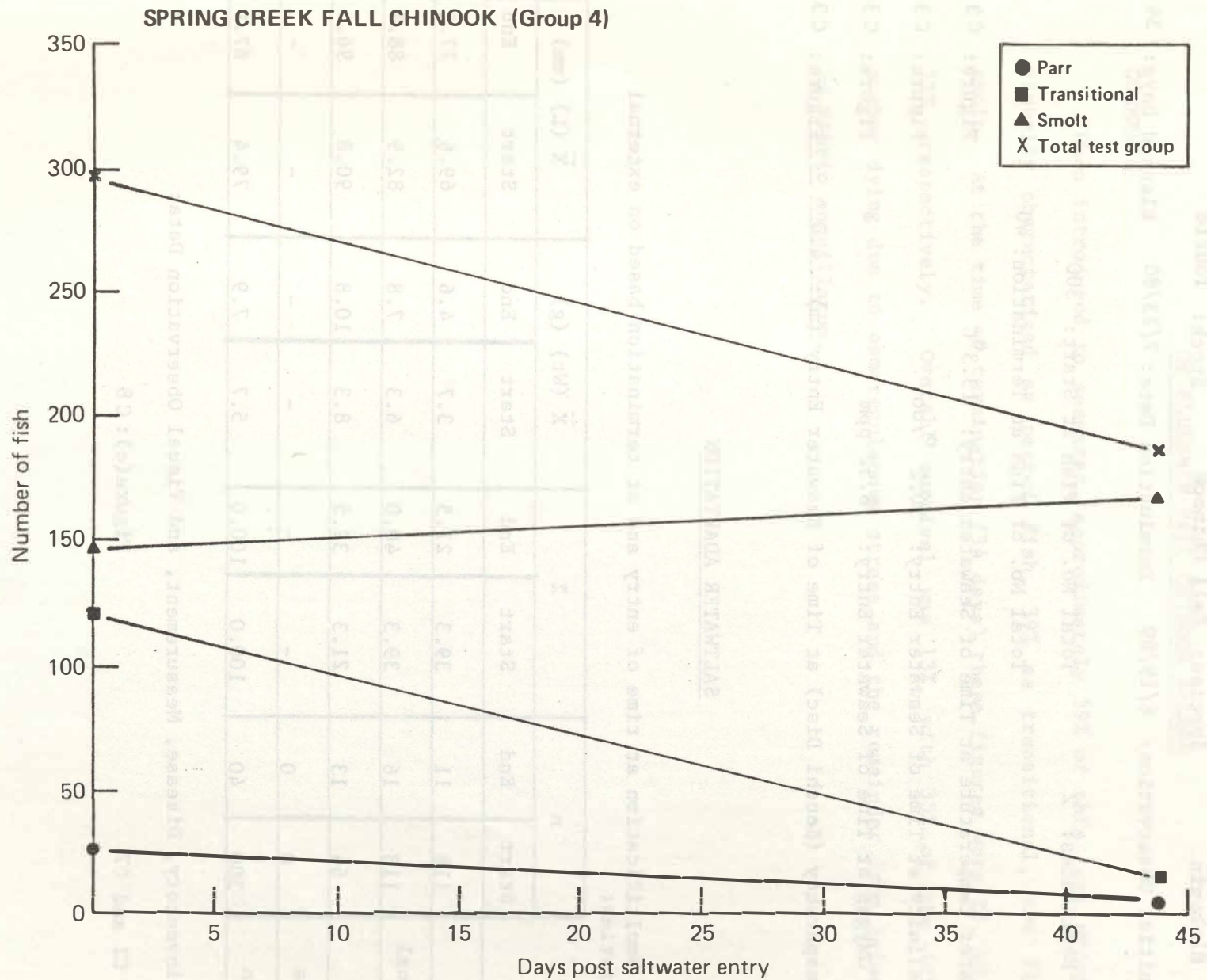

Figure C7--Number of parred, transitional, and smolted fish (staging based on external characteristics) and total test group survival in seawater vs time.

TEST GROUP SYNOPSIS

Hatchery: Elokomin Species: Fall Chinook Stock: Toutle

Date of Initial Observation: 6/19/80 Termination Date: 7/23/80 Elapsed Days: 34

Number of Replicates: 2 Total No. of Fish at Start: 300

Total No. of Fish at Termination: 40

Surface Water Temperature at Time of Seawater entry: 13.3^oC Figure: C3

Surface Salinity at Time of Seawater Entry: 30.2 ‰ Figure: C3

Dissolved Oxygen at Time of Seawater Entry: 8.52 ppm Figure: C3

Water Transparency (Secchi Disc) at Time of Seawater Entry (m): 4.0 Figure: C3

SALTWATER ADAPTATION

Status of smoltification at time of entry and at termination based on external characteristics:

	n		%		\bar{X} (Wt) (g)		\bar{X} (L) (mm)	
	Start	End	Start	End	Start	End	Start	End
Parr	118	11	39.3	27.5	3.7	4.6	69.6	77.2
Transitional	118	16	39.3	40.0	6.3	7.8	82.9	88.4
Smolt	64	13	21.3	32.5	8.3	10.8	90.8	96.4
Precocious	0	0	-	-	-	-	-	-
Population	300	40	100.0	100.0	5.7	7.9	79.4	87.9

Seawater Inventory, Disease, Measurement, and Visual Observation Data:

Table(s): C2 and C7

Figure(s): C8

OVERALL SEAWATER ADAPTATION
OF ELOKOMIN FALL CHINOOK SALMON

COMMENTS

When introduced to seawater, approximately 39% of this test group was visually characterized as parred fish, 39% as transitional, and 21% as smolt. At the time of termination (34 days) these figures were 28, 40, and 32%, respectively. Overall survival was 13%, with 35% of the initial number dying due to osmoregulatory stress and the remainder from infection by Vibrio anguillarum.

ELOKOMIN FALL CHINOOK

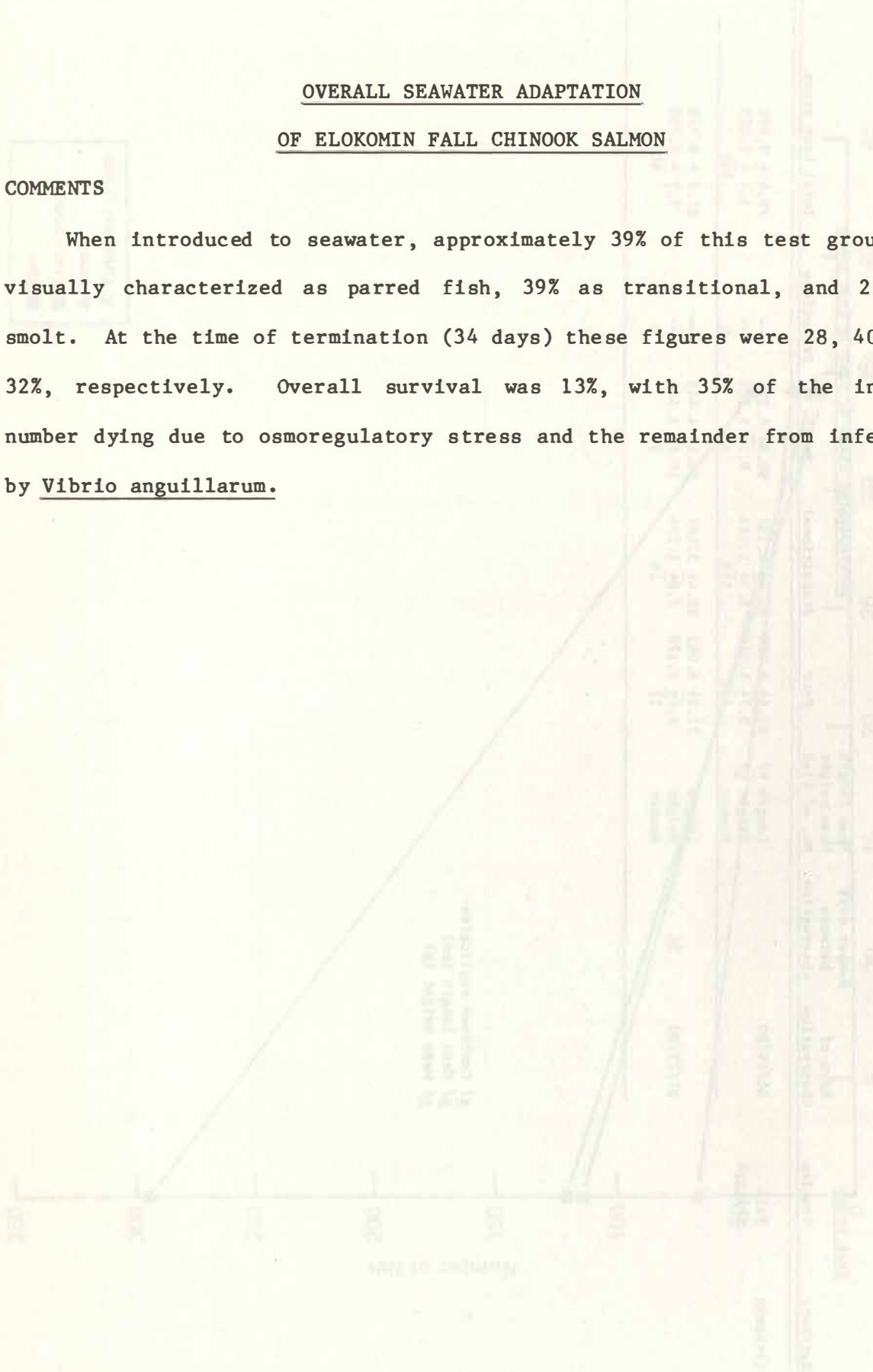

Table C7.--Length and weight of fish during different stages of development in seawater.^{a/}

Hatchery	Test Group Species	Days of Observation	Number days between observation	Mean length Mean weight No. of fish	Developmental stage of fish in test group									
					Parr	Transitional	Smolt	Precocious	Total test group					
Elokomin	Fall Chinook	06/19/80		Length b/ Weight c/ Number	69.6+ 3.7+ 118	6.980 1.040	82.9+ 6.3+ 118	4.157 1.016	90.8+ 8.3+ 64	4.321 1.307	---	---	0	79.4 + 9.990 5.7 + 2.075 300
		07/23/80	34	Length Weight Number	77.2+ 4.6+ 11	6.063 1.178	88.4+ 7.8+ 16	3.164 1.236	96.4+ 10.8+ 13	4.445 1.646	---	---	0	87.9 + 8.778 7.9 + 2.758 40

a/ Combined replicates
b/ Mean length (mm)
c/ Mean weight (g)

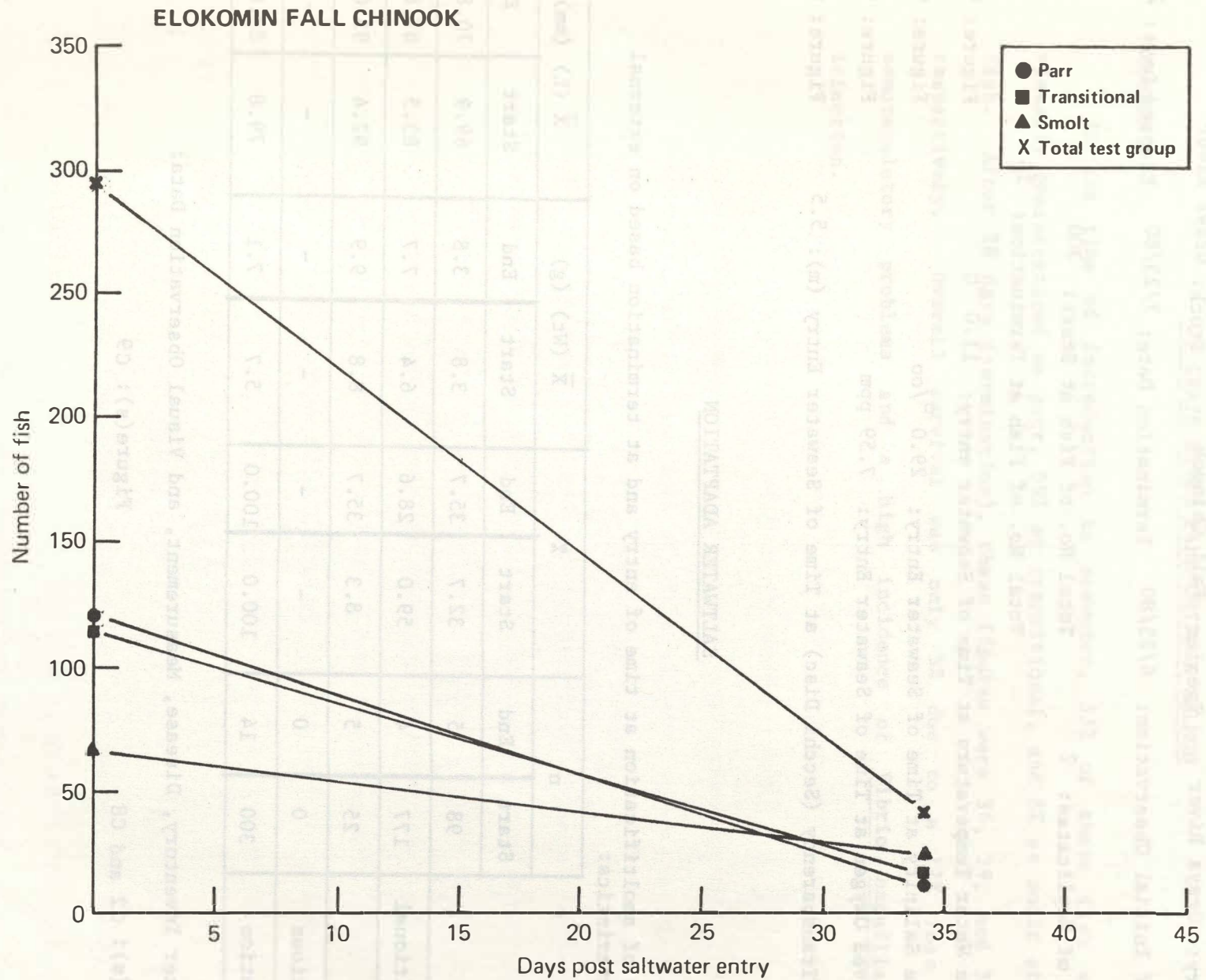

Figure C8--Number of parred, transitional, and smolted fish (staging based on external characteristics) and total test group survival in seawater vs time.

TEST GROUP SYNOPSIS

Hatchery: Grays River Species: Fall Chinook Stock: Grays River

Date of Initial Observation: 6/25/80 Termination Date: 7/23/80 Elapsed Days: 28

Number of Replicates: 2 Total No. of Fish at Start: 300

Total No. of Fish at Termination: 14

Surface Water Temperature at Time of Seawater entry: 11.0 °C Figure: C3

Surface Salinity at Time of Seawater Entry: 29.0 ‰ Figure: C3

Dissolved Oxygen at Time of Seawater Entry: 7.59 ppm Figure: C3

Water Transparency (Secchi Disc) at Time of Seawater Entry (m): 5.5 Figure: C3

SALTWATER ADAPTATION

Status of smoltification at time of entry and at termination based on external characteristics:

	n		%		\bar{X} (Wt) (g)		\bar{X} (L) (mm)	
	Start	End	Start	End	Start	End	Start	End
Parr	98	5	32.7	35.7	3.8	3.8	69.9	70.8
Transitional	177	4	59.0	28.6	6.4	7.7	83.5	87.8
Smolt	25	5	8.3	35.7	8.8	9.9	92.4	93.0
Precocious	0	0	-	-	-	-	-	-
Population	300	14	100.0	100.0	5.7	7.1	79.8	83.6

Seawater Inventory, Disease, Measurement, and Visual Observation Data:

Table(s): C2 and C8

Figure(s): C9

OVERALL SEAWATER ADAPTATION
OF GRAYS RIVER FALL CHINOOK SALMON

COMMENTS

At the time of introduction to seawater, 33% of these fish were visually characterized as parr, 59% as transitional, and 8% as smolt stage fish. After 28 days (termination), these figures were 36, 29, and 36%, respectively. Overall survival was only 5% due to a 17% loss to osmoregulatory problems and a high incidence of Vibrio anguillarum infection.

Size, time, growth status, and type of handling are among the factors determining initial survival of fall chinook salmon introduced directly to seawater (COTE and FRED 1979 and HENNINGSEN et al. 1980). These factors are interrelated, and it is difficult to make a definite statement about a single factor. Mortality within the first 10 to 15 days following seawater entry was generally high. Osmoregulatory problems usually affected the gillnet, streamer, and net populations. Fish suffering this problem showed signs of severe dehydration (shrinkage of the skin). Mortality accounted by most of the mortality was directly associated with osmoregulatory difficulties.

It was observed in past studies that, in general, the higher the mean size at seawater entry, the higher the number of smolts and overall survival. In the present study, the first seawater entry group (Group 1) had the lowest mean size and lowest number of smolts of the four aerial releases from the hatchery. This group, however, had the highest seawater survival. Unlike previous years however, this first

Table C8.— Length and weight of fish during different stages of development in seawater. ^{a/}

Test group		Days of observation	Number days between observation	Mean length Mean weight No. of fish	Developmental stage of fish in test group				Total test group
Hatchery	Species				Parr	Transitional	Smolt	Precocious	
Grays River	Fall Chinook	06/25/80		Length b/ Weight c/ Number	69.9 ± 6.786 3.8 ± 1.229 98	83.5 ± 4.648 6.4 ± 1.090 177	92.4 ± 2.752 8.8 ± 1.019 25	--- --- 0	79.8 ± 9.032 5.7 ± 1.895 300
		07/23/80	28	Length Weight Number	70.8 ± 2.864 3.8 ± 0.643 5	87.8 ± 3.096 7.7 ± 0.424 4	93.0 ± 3.391 9.9 ± 1.341 5	--- --- 0	83.6 ± 10.515 7.1 ± 2.809 14

a/ Combined replicates

b/ Mean length (mm)

c/ Mean weight (g)

SUMMARY

Based on the information collected on fall chinook salmon at the Manchester Marine Experimental Station over the past several years, the test fish for 1980 were held in seawater for only about 30 days. This period provided much of the information needed to assess seawater adaptation. However, some data were lost following this procedure, e.g., data related to the occurrence of BKD. This pathogen was isolated in several of the test groups prior to seawater entry (Appendix D); however, it was not found in seawater samples. This pathogen normally manifests itself in fish only after about a month of seawater exposure.

Size, time, disease status, and rate of smoltification are among the factors determining initial survival of fall chinook salmon introduced directly to seawater (CZES and ETSD 1979 and Prentice et al. 1980). These factors are interrelated, and it is difficult to make absolute statements about a single factor. Mortality within the first 10 to 15 days following seawater entry was generally related to osmoregulatory dysfunction. Osmoregulatory problems usually affected the smaller, nonsmolting fish in the test populations. Fish suffering this problem showed signs of severe dehydration (rippling of the skin). Vibriosis accounted for most of the mortalities not directly associated with osmoregulation difficulties.

It was observed in past studies that in general, the higher the mean size at seawater entry, the higher the number of smolts and overall survival. In the present study, the first seawater entry group from Spring Creek NFH (Table C1) had the lowest mean size and lowest number of smolts of the four serial releases from the hatchery. This group, however, had the highest seawater survival. Unlike previous years however, this first

release group (March) had the highest gill $\text{Na}^+\text{-K}^+$ ATPase activity of the four releases. In addition, at the time of seawater entry, surface seawater temperatures were generally lower than at the time of later entries, thus minimizing the occurrence of vibriosis. It would appear then that biochemical determination of the status of smoltification in fresh water should be considered in addition to size and external characteristics for assessing seawater readiness of fall chinook salmon.

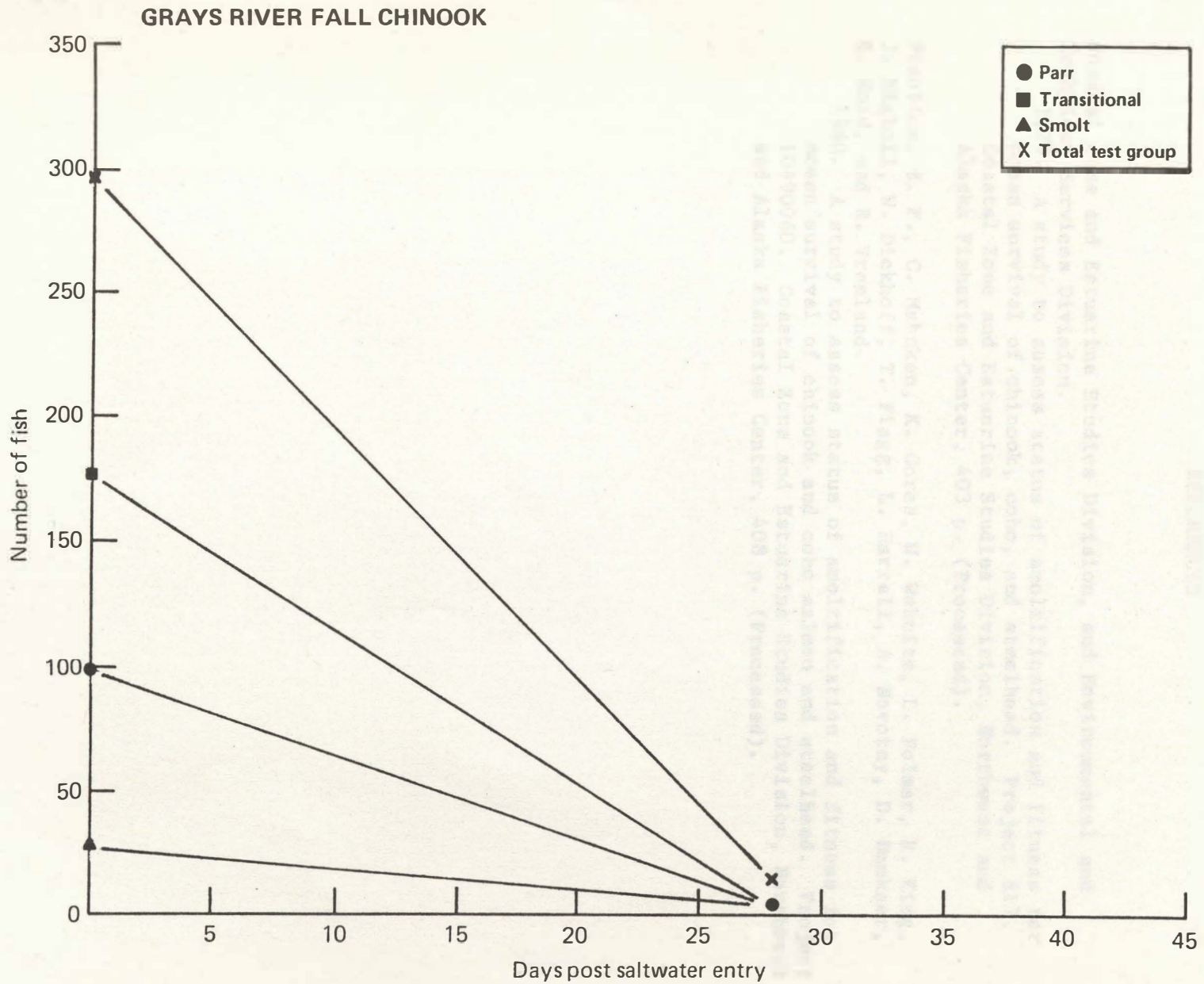

Figure C9.--Number of parred, transitional, and smolted fish (staging based on external characteristics) and total test group survival in seawater vs time.

REFERENCES

Coastal Zone and Estuarine Studies Division, and Environmental and Technical Services Division.

1979. A study to assess status of smoltification and fitness for ocean survival of chinook, coho, and steelhead. Project 817. Coastal Zone and Estuarine Studies Division, Northwest and Alaska Fisheries Center, 403 p. (Processed).

Prentice, E. F., C. Mahnken, K. Gores, W. Waknitz, L. Folmar, R. King, J. Mighell, W. Dickhoff, T. Flagg, L. Harrell, A. Novotny, D. Damkaer, E. Wold, and R. Vreeland.

1980. A study to assess status of smoltification and fitness for ocean survival of chinook and coho salmon and steelhead. Project 10990060. Coastal Zone and Estuarine Studies Division, Northwest and Alaska Fisheries Center, 408 p. (Processed).

APPENDIX D

FISH HEALTH, A GENERAL EVALUATION

by

Lee W. Harrell, Anthony J. Novotny

and

C. Gunnar Safsten

INTRODUCTION

During 1980, National Marine Fisheries Service (NMFS) personnel at the Manchester Marine Experimental Station documented the health status of the fall chinook salmon target stocks in both fresh water and seawater and coho salmon target stocks in the freshwater hatchery only. This evaluation included an examination of hatchery records concerning the culture and treatment of fish, determination of the incidence of latent bacterial kidney disease (BKD), and the monitoring of fall chinook salmon mortalities during a seawater holding period.

METHODS AND MATERIALS

Hatchery Records

Records were obtained from the hatcheries and pertinent information regarding the culture of the fish was documented. This information included: diets, environment, diseases and treatment, total mortality, size of fish at release, and date of release. In cases where fish populations were released on several dates, the life history data apply up to the last serial release. Table D1 is a synopsis of collected hatchery data.

Bacterial Kidney Disease

The indirect fluorescent antibody technique (IFAT) was used to diagnose latent BKD in hatchery populations. The number of fish sampled for the analysis was based on the work of Ossiander and Wedemeyer (1973), who showed that a single disease incidence of 5% or greater can be detected with a sample of 60 fish from populations of 100,000 individuals. The fish were opened ventrally and the kidney exposed. Thin smears of a mixture of

Table D1.--Disease and treatment of hatchery juveniles.

Hatchery	Species	Date of egg take	Date ponded	Date hatchery release	Feed	Water source	Water temp °C	Disease	Medication		
Spring Creek NFH	Fall chinook	9/17-18/79	12-10-79	3-10-80	OMP II	Spring	8.3-11.1	Accumulation of feed particles on gill	Increased food size 2-13-80		
				4-10-80				2-8-80	Reduce wt in ponds		
				5-09-80				3-10-80	Live liquid micro-organisms (LLMO)		
				8-07-80				4-3-80	LLMO		
								5-14-80	None		
		7-7-80									
Elokomin	Fall chinook	<u>a/</u>	4-15-80	6-19-80	OMP II	Elokomin River	<u>a/</u>	Minor Costia			
								Eichthyophthirius and Epistylis	3-29-80	Formalin 1:6000 for 1 hr	
								Light Epistylis	3-14-80	None	
Grays River	Fall chinook	11/19/79 10/23,25,30	1-22-80	6-24-80	OMP	Grays River	13.3	Costia	5-20-80	Formalin 1:6000/hr 5-22-80	
			2-04-80						Coagulated yolk problems since ponding Gas bubble, fungused fins caused most of loss.		
Bic Creek	Coho	11/2-15/78	2-27-79	5-07-80	OMP	Big Creek	<u>a/</u>	None			
				6-06-80							
				7-07-80							
Washougal	Coho	2/14&22/79	3-25-79	5-08-80	OMP II	Washougal River	12.2	Low temp.	5-19-80	2% TM-50 in diet-10 days	
				6-09-80					Ichthyophthirius	8-13-79	Formalin Drip 25 ppm-12 days reduced to 1%
				7-07-80					Low temp. & BKD	5-24-80	TM-50 8% reduced to 1% in diet-10 days

a/ No data available.

b/ Pond loss prior to release appeared to show some pathology (internal and external hemorrhage) loss in pond low (200/day) mostly pinheads. 5% sampled on 4-25-80 transfer.

anterior and posterior kidney tissue were made on multi-spot slides after piercing the kidney with a sterile inoculation loop.

The IFAT for BKD was originally described by Bullock and Stuckey (1975) and later modified by G. W. Camenisch of the U.S. Fish and Wildlife Service (USFWS), Eastern Fish Disease Laboratory. A more detailed description of the methods and material used in this assay is found in CZES and ETSD (1979).

Mortalities in Seawater

Mortalities in the seawater pens were collected daily. Those that were not decomposed were opened from the vent, and external and internal lesions were noted. Procedures described by Novotny et al. (1975) for culturing and identifying vibriosis and other gram-negative bacteria were followed.

The mortalities were classified as follows:

- a. Cause unknown.
- b. BKD (diagnosed from observations of gross granulomatous lesions).
- c. Vibriosis.
- d. Enteric red mouth disease (ERM).
- e. Osmoregulatory dysfunction.
- f. Furunculosis

RESULTS AND DISCUSSION

Hatchery Records

The effect of husbandry techniques on fish health and smolt quality is substantial. Many chemotherapeutic compounds used in the treatment of parasitic and bacterial diseases of fish can affect the smolting process

(Schmidt-Nielsen 1974, Lorz and McPherson 1976). Chemotherapeutic compounds were used on many of the test groups in this study during various phases of freshwater rearing; however, only the Washougal coho salmon were treated near the time of release (Table D1).

Incidence of Latent Bacterial Kidney Disease

The 60 fish sampled at the time of release from the hatchery were assayed for latent infections of Renibacterium salmoninarum, the gram positive bacterium responsible for BKD (Sanders and Fryer 1980). The percentage of the sampled hatchery fish diagnosed as carriers of the bacterium are shown below:

<u>Hatchery</u>	<u>Species</u>	<u>BKD Detected (%)</u>
Spring Creek	Fall chinook	6.7
Grays River	Fall chinook	1.7
Elokomin	Fall chinook	0.0
Big Creek	Coho	13.3
Washougal	Coho	8.3

BKD is a chronic pathological condition affecting salmonids in fresh water and may be the cause of mortality in fish at any time during seawater residence. The effect of this or any other disease in the latent stage on the smoltification process is unknown.

Mortality after Transfer to Seawater Net-Pens

Table D2 is a summary of survival data and the principal causes of mortalities for the groups tested in seawater net-pens at Manchester. The heavy losses due to vibriosis occurred during the warmer months when the surface seawater temperature was 13°-15°C. This mortality, therefore, was not unexpected in unvaccinated fish held in net-pens at Manchester.

Table D2.--Inventory and seawater disease record of fall chinook salmon test groups.

INVENTORY RECORD

Test group	No. fish at start of study	No. fish at termination & % survival		Total loss of fish (No.)	Total re-covered mortalities (No.)	Total unre-covered mortalities		Recovered mortalities not examined (decomposed)		Recovered mortalities examined	
		(No.)	(%)			(No.)	(%)	(No.)	(%)	(No.)	(%)
<u>Fall Chinook</u>											
Spring Creek (Group 1)	300	266	88.7	34	32	2	0.7	12	4.0	20	6.7
Spring Creek (Group 2)	300	205	68.3	95	93	2	0.7	31	10.3	62	20.7
Spring Creek (Group 3)	300	15	5.0	285	281	4	1.3	171	57.0	110	36.7
Elokomin	300	40	13.3	260	249	11	3.7	123	41.0	126	42.0
Grays River	300	14	4.7	286	282	4	1.3	208	69.3	74	24.7
Spring Creek (Group 4)	300	187	62.3	113	95	18	6.0	86	28.7	9	3.0

PATHOLOGIST'S DIAGNOSIS OF MORTALITIES IN SEAWATER

	Nega-tive	BKD ^{a/}	<u>Vibrio</u> ^{b/} spp.	ERM ^{c/}	<u>Aero</u> ^{d/} liq	Osmo ^{e/} dys	Furun ^{f/}
<u>Fall Chinook</u>							
Spring Creek (Group 1)	0	0	0	0	0	20	0
Spring Creek (Group 2)	7	0	12	0	0	43	0
Spring Creek (Group 3)	5	0	59	0	0	46	0
Elokomin	1	0	22	0	0	103	0
Grays River	0	0	25	0	0	49	0
Spring Creek (Group 4)	1	1	7	0	0	0	0

^{a/} Bacterial Kidney Disease

^{b/} Vibrio anguillarum strains 775, 1669, 7244

^{c/} Enteric Red Mouth

^{d/} Aeromonas liquefaciens

^{e/} Osmoregulatory dysfunction

^{f/} Furunculosis

REFERENCES

Bullock, G. L., and H. M. Stuckey.

1975. Fluorescent antibody identification and detection of the *Corynebacterium* causing kidney disease of salmonids. *J. Fish. Res. Bd. Can.* 32(11):2224-2227.

Coastal Zone and Estuarine Studies Division and Environmental and Technical Services Division.

1979. A study to assess status of smoltification and fitness for ocean survival of chinook, coho, and steelhead. Project 817. Coastal Zone and Estuarine Studies Division, Northwest and Alaska Fisheries Center, 403 p. (Processed).

Lorz, H. W., and B. P. McPherson.

1976. Effects of copper or zinc in freshwater on the adaptation to seawater and ATPase activity and the effects of copper on migratory disposition of coho salmon *Oncorhynchus kisutch*. *J. Fish. Res. Bd. Can.* 33(9):2023.

Novotny, A. J., L. W. Harrell, and C. Nyegaard.

1975. Vibriosis: A common disease of Pacific salmon cultured in marine waters of Washington. *Wash. State Univ. Ext. Bull.* 663:1-8.

Ossiander, F. J., and G. Wedemeyer.

1973. Computer program for sample sizes required to determine disease incidence in fish populations. *J. Fish. Res. Bd. Can.* 30:1383-1384.

Sanders, J. E., and J. L. Fryer.

1980. *Renibacterium salmoninarum* Gen. Nov., Sp. Nov., the causative agent of bacterial kidney disease in salmonid fishes. *Int. J. Syst. Bact.* 30(2):496-502.

Schmidt-Nielsen, B.

1974. Osmoregulation: Effect of salinity and heavy metals. *Fed. Proc.* 33(10):2137.

APPENDIX E

BIOCHEMICAL, MORPHOLOGICAL, AND PICTORIAL
DOCUMENTATION OF SMOLTIFICATION

by

Earl F. Prentice

F. William Waknitz

James L. Mighell

INTRODUCTION

Accurate recognition of the progressive stages of the parr-smolt transformation is essential for those involved with salmon production or various aspects of salmon research. Visual criteria alone are often the sole basis for: (1) describing status of smoltification, (2) determining migration ability, and (3) determining seawater adaptability of salmon. However, there are differences of opinion in terminology and the general description of each stage of parr-smolt transformation. Often several descriptions are applied to fish of essentially the same stage. To reduce this confusion, standardized descriptions and reference criteria are required. Toward this end, a series of descriptions and photographs are presented for coho salmon, Oncorhynchus kisutch. Drawings and morphological and physiological measurements for coho salmon and criteria for other species of the genus Oncorhynchus will be presented at a later date.

METHODS AND MATERIALS

Freshwater and Seawater Rearing

Coho salmon in a late parr (presmolt) stage were obtained from the Skykomish Hatchery (WDF) in mid-February 1980 and transported to the Northwest and Alaska Fisheries Center (NWAFC) in Seattle where they were reared in 1.5-m diameter, light green, circular tanks. The tanks were continuously supplied with dechlorinated municipal water at a velocity of 0.5 to 1.0 body length per second. Rearing density was 24 kg/m³. The fish were located outdoors under natural light. Dissolved oxygen was monitored daily and maintained at or near saturation at all times by controlling flow rate. The pH varied between 6.4 and 6.8. Ammonia nitrogen levels from fish excretions were less than 0.64 ppm total ammonia nitrogen,

measured by direct nesslerization; the equivalent un-ionized ammonia equals 0.00054 ppm. Un-ionized ammonia of 0.0125 ppm or lower is not harmful to trout (Smith and Piper 1975). The incoming water was supplied at ambient temperature and ranged from 4.9° to 14.7°C.

Two disease problems were encountered during freshwater rearing. The first, a myxobacterial disease, was treated from 12 March to 22 March 1980. Fish were fed food containing 2% active ingredient Terramycin^{1/} at a rate of 4% body weight per day. The disease was controlled successfully with only 0.3% of the population succumbing to the disease. The second disease, furunculosis, Aeromonas salmonicida, was treated with chloramphenicol at a level of 0.3% active ingredient in the feed from 14 April to 28 April 1980. The epizootic caused a 3.6% mortality before it was controlled.

To document the changes in external appearance and morphological characteristics in seawater, several hundred fish were transferred from the NWAFC to the Manchester Marine Experimental Station in June 1980. The fish were maintained in seawater net-pens until November 1980. Seawater rearing conditions: surface water temperature, water transparency, dissolved oxygen, and salinity were within the accepted limits for coho salmon (Figure E1). Vibriosis was the primary cause of death during seawater rearing.

Visual Criteria for Stages in the Parr-Smolt Transformation

The fish were examined in both fresh water and seawater for changes that occur during the smoltification process. Visual cues, including body color, fin color, and presence or absence of parr marks were used to

^{1/} Reference to trade names does not imply endorsement by the National Marine Fisheries Service, NOAA.

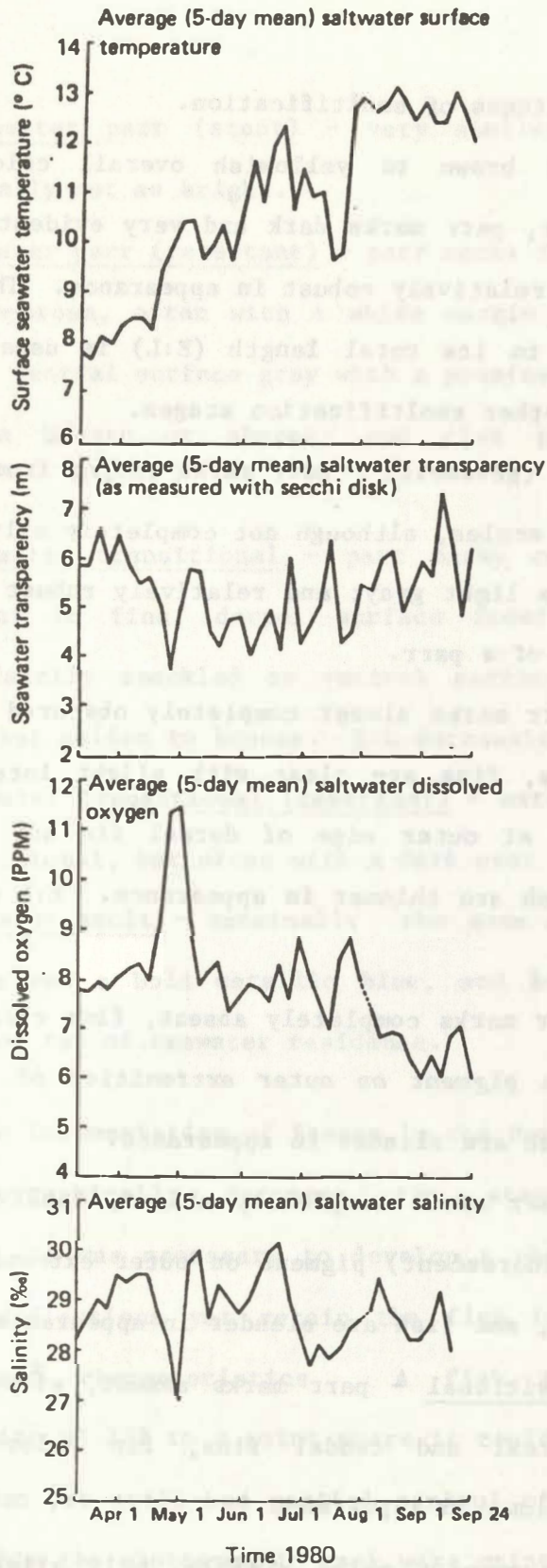

Figure E1.--Environmental data at Manchester Marine Experimental Station, Clam Bay, Washington.

designate the following stages of smoltification.

(1) Parr - light brown to yellowish overall color, yellow to brownish-orange fin color, parr marks dark and very evident, little or no silvering of scales, and relatively robust in appearance. The ratio of the fish's eyeball diameter to its total length (E:L) is usually greater in parr stage fish than in other smoltification stages.

(2) Transitional - (presmolt) - parr marks fading from sight because of guanine deposition in scales, although not completely silvery; fin color becoming clear or uniform light gray; and relatively robust in appearance. E:L decreasing from that of a parr.

(3) Smolt #1 - parr marks almost completely obscured by the silvery appearance of the scales, fins are clear with slight intensification of black pigment (melanin) at outer edge of dorsal fin and extremities of caudal fin lobes, and fish are thinner in appearance. E:L decreasing from that of a transitional.

(4) Smolt #2 - parr marks completely absent, fins clear with greater intensification of black pigment on outer extremities of dorsal fin and caudal fin lobes, and fish are slender in appearance.

(5) Smolt #3 - parr marks completely absent, fins clear with very intense black (almost fluorescent) pigment on outer extremities of dorsal fin and caudal fin lobes, and fish are slender in appearance.

(6) Reverted transitional - parr marks absent, silvery body, black pigment faded from dorsal and caudal fins, fin color now clear to yellowish, and body is plump in appearance.

(7) Reverted parr - parr marks visible, only slight silvering of scales, fin color yellow and sometimes with black spots on dorsal and caudal fins, overall yellowish to brownish-yellow body color, and body is plump in appearance.

(8) Seawater parr (stunt) - very similar to a freshwater parr, although generally not as bright.

(9) Seawater parr (revertant) - parr marks faintly to boldly evident; fins to orange-brown, often with a white margin on the anal fin; dorsal surface brown; ventral surface gray with a prominently mottled appearance; external sheen bronze or absent; and fish generally very thin and pinheaded.

(10) Seawater transitional - parr marks partially visible, yellow pigment evident in fins, dorsal surface faded from metallic blue to green-brown, faintly speckled on ventral surface, and overall sheen no longer silver but golden to bronze. E:L decreasing from that of a parr.

(11) Seawater transitional (revertant) - externally very similar to a seawater transitional, but often with a dark cast to the lateral surface.

(12) Seawater smolt - externally the same as freshwater Smolt #3, dorsal surface now a bold metallic blue, and body form is again robust after a month or two of seawater residence.

Photographic Documentation of Stages in the Parr-Smolt Transformation

To photographically document the stages in the parr-smolt transformation, it was necessary to develop a photographic technique that would reduce reflections yet retain the fish in a position showing the desired, typical characteristics. A fish to be photographed was tranquilized with MS 222 to a point where it could not maintain position in the water column yet still had partial control of its fins. Static water conditions within the photographic tank were maintained during photographic sessions. Prior to taking a picture, a fish was positioned near the

surface of the tank using a saddle-like probe. The fish was then allowed to drop through the water column as the photograph was taken.

All photographs were taken by a commercial photographer using a Leicaflex SL Camera equipped with a Leitz 65mm f4 lens and bellows attachment. Lighting was provided by two Minolta Model 320 strobes and a Rollei 121BC strobe to illuminate the background. One of the Minolta strobes was used as a master controlling the other two. All strobes operated in the automatic light cut-off mode. The energy output, measured in beam-candlepower seconds (BCPS), was determined for each strobe with a Calca Flash meter. Light energy output was 1600 BCPS units for each Minolta strobe (yellow auto mode) and 1500 BCPS units for the Rollei strobe. All potential reflective surfaces were either painted with a black matte spray or covered with a black cloth. The film used was Ektachrome ER-135 (ASA 64). An exposure of f8-11 at 1/100 s was found to be best for most subjects. Bracketing at f8 and f11 was occasionally done for confirmation. The background was #1080 blue drawing board manufactured by Crescent Cardboard Company. The photographic arrangement of distances and angles of subject to film plane is shown in Figures E2 and E3.

Physiological and Morphological Measurements

In fresh water a representative sample of 30 fish, all at the same stage of smoltification (visual criteria), were collected whenever the majority of the population was judged to be at a specific stage of smoltification. The fish provided both physiological and morphological information.

Tissue and blood samples were taken from each of the 30 fish subsampled. Determinations of gill sodium-potassium adenosine triphosphatase ($\text{Na}^+ - \text{K}^+$ ATPase), plasma thyroxine (T_4), and plasma

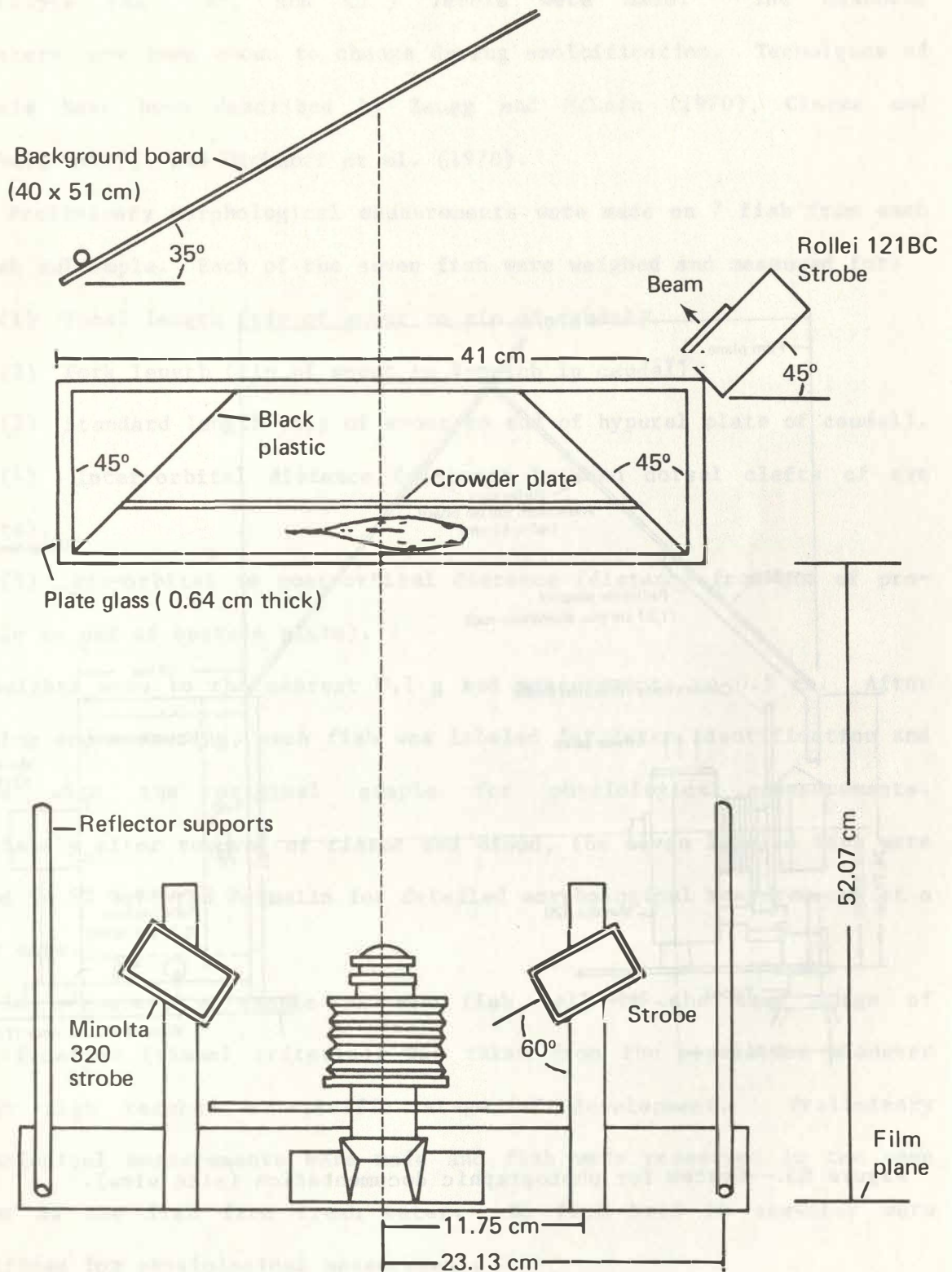

Figure E2.--System for photographic documentation (top view).

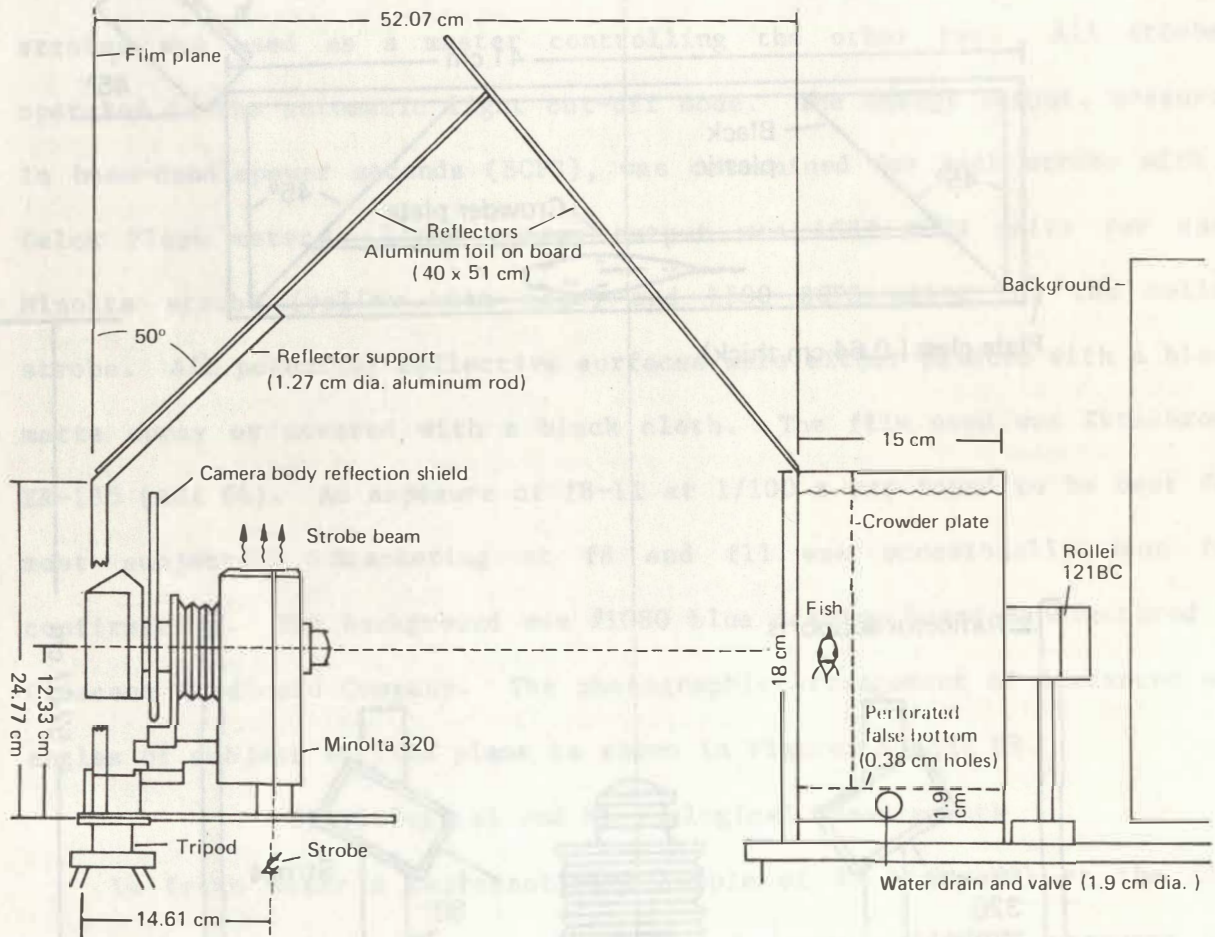

Figure E3.--System for photographic documentation (side view).

electrolyte (Na^+ , K^+ , and Cl^-) levels were made. The measured parameters have been shown to change during smoltification. Techniques of analysis have been described by Zaugg and McLain (1970), Clarke and Blackburn (1977), and Dickhoff et al. (1978).

Preliminary morphological measurements were made on 7 fish from each 30-fish subsample. Each of the seven fish were weighed and measured for:

- (1) Total length (tip of snout to tip of caudal).
- (2) Fork length (tip of snout to V-notch in caudal).
- (3) Standard length (tip of snout to end of hypural plate of caudal).
- (4) Inter-orbital distance (distance between dorsal clefts of eye sockets).
- (5) Pre-orbital to post-orbital distance (distance from end of pre-opercle to end of opercle plate).

All weights were to the nearest 0.1 g and measurements to 0.5 mm. After weighing and measuring, each fish was labeled for later identification and placed with the original sample for physiological measurements. Immediately after removal of tissue and blood, the seven labeled fish were placed in 5% buffered Formalin for detailed morphological measurements at a later date.

In seawater, a sample of six fish, all in the same stage of smoltification (visual criteria), was taken from the population whenever enough fish reached a specific stage of development. Preliminary morphological measurements were made and fish were preserved in the same manner as the fish from fresh water. No fish held in seawater were sacrificed for physiological measurement.

Methods and materials used in the detailed morphological characterization of each fish sample taken in both fresh water and seawater

will be presented in an addendum to this report upon completion of the work.

RESULTS AND DISCUSSION

Photographic Documentation of Progressive Stages in the Parr-Smolt Transformation

In this report, only select black and white pictures will be presented because of the high reproduction cost of color photographs. Some detail is lost, however, due to the absence of color; therefore, all of the stages in the parr-smolt transformation are not depicted here. Photographs showing three stages of smoltification in both fresh water and seawater are presented in Figures E4 and E5. Descriptions of these stages are presented in Tables E1 and E2.

Photographic procedures that result in a uniform background have yet to be developed (Figures E4 and E5). The same techniques were used for all photographs, yet differences were evident in the coloration of the background. A uniform background is necessary for photographic comparison of stages in the parr-smolt transformation. Tests are presently being conducted to satisfy this requirement.

It must be emphasized that orientation of the fish in relation to the viewer is critical for an accurate smolt-stage assessment. For example, a fish with parr marks (parr to late transitional stage), can be held at an angle so that light reflects from the scales and completely masks the parr marks, resulting in a false determination of the fish's stage. Therefore, it must be emphasized that all external criteria--skin color, fin color, parr marks, condition, opercle sheen, and eyeball/length ratio--must be integrated for an accurate interpretation.

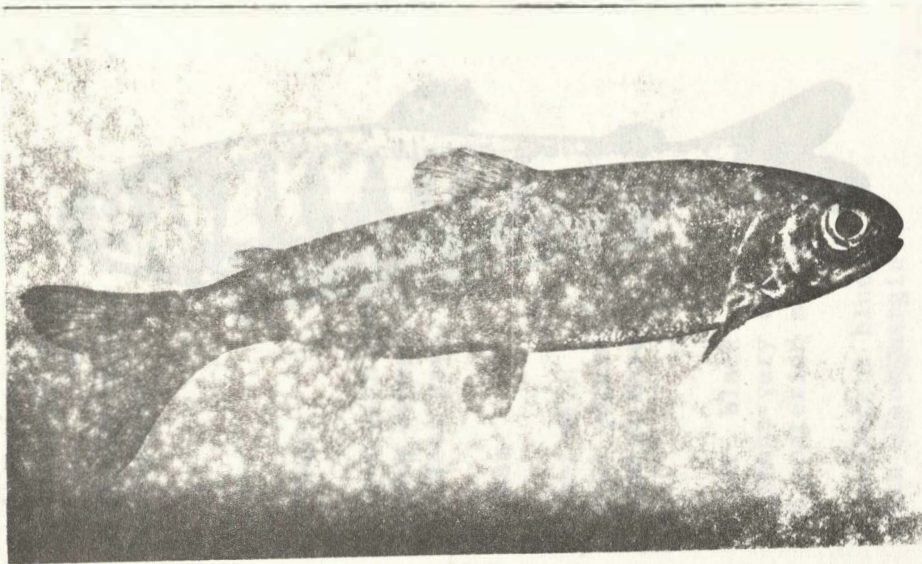

PARR

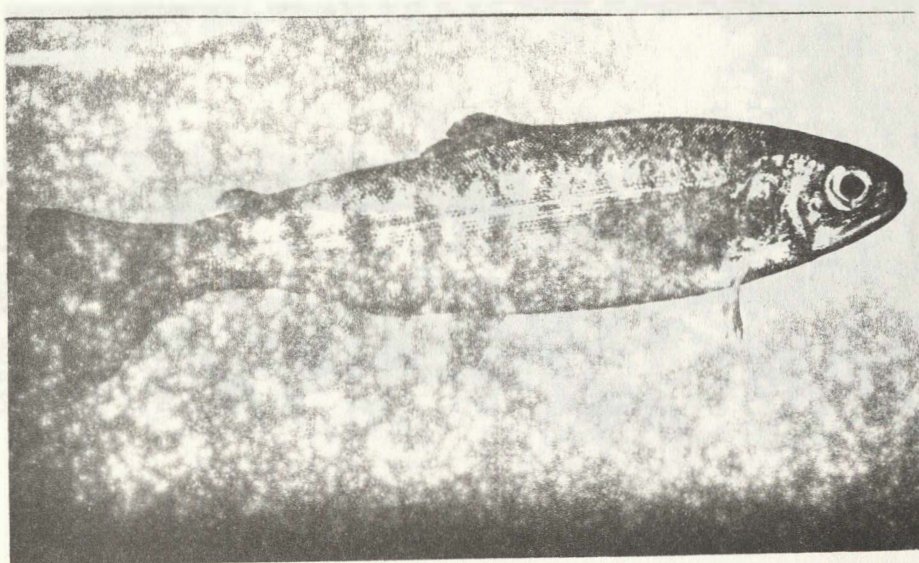

TRANSITIONAL

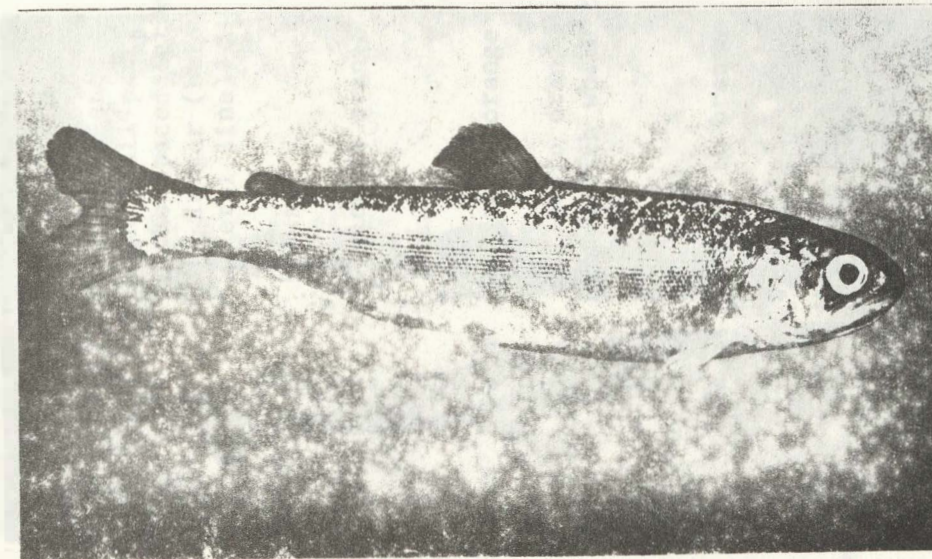

SMOLT

Figure E4.--Three stages in the parr-smolt transformation of coho salmon in fresh water. Visual criteria for each stage are described in Table E1.

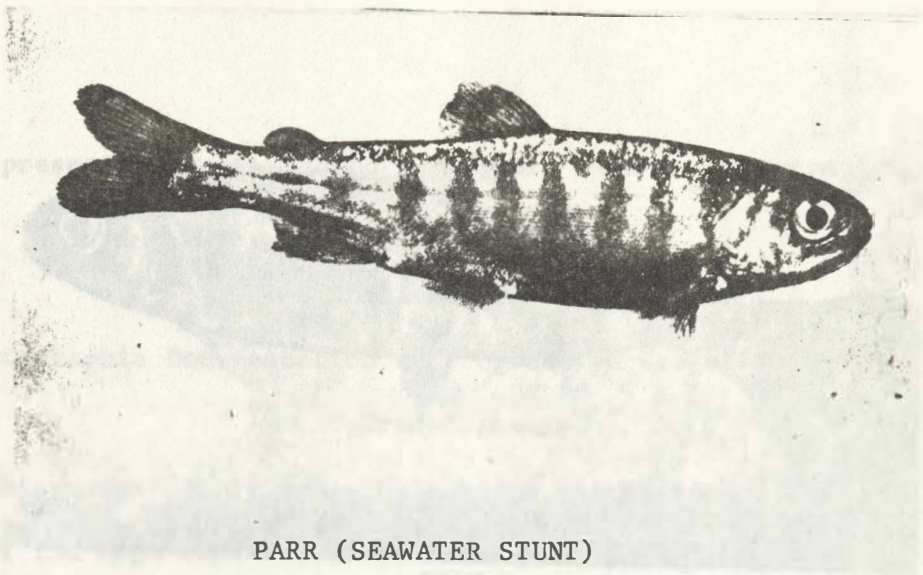

PARR (SEAWATER STUNT)

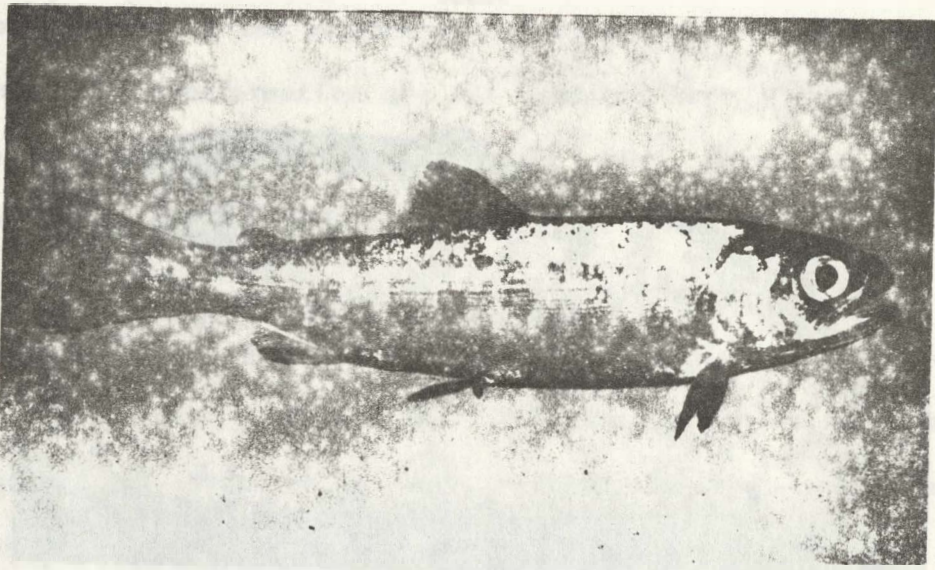

TRANSITIONAL



SMOLT

Figure E5.--Three stages in the parr-smolt transformation of coho salmon in seawater. Visual characteristics for each stage are described in Table E2.

Table E1.--Visual characteristics of coho salmon for stages of smoltification in fresh water.

	Parr	Transitional	Smolt
Color	Brown dorsally, yellow ventrally	Greenish dorsally, cream ventrally	Blue dorsally, silver/white ventrally
Parr marks	Bold, evident, with small parr marks spaced between the larger (below the lateral line)	Fading, small ventral parr marks absent, parr marks reduced in width	Faintly visible to absent
Condition	Robust	Robust to slim	Slender
Pectoral fins	Yellow to orange	Yellow to gray	Clear with some black pigment between rays
Ventral fins	Yellow to orange	Clearing	Clear
Anal fin	Yellow to orange often with white tip	Clear, white tip often present, some black pigment between rays	Clear with black pigment between rays
Caudal fin	Yellow to orange	Clear, black pigment forming on posterior margin	Clear, black pigment very evident on posterior margin
Adipose fin	Translucent brown	Translucent green	Translucent blue with black margin
Dorsal fin	Translucent brown, spotted	Translucent green, spotted, black pigment forming on margin	Translucent blue, spotted, black pigment very evident on margin
Opercle	Golden sheen	Bronze sheen	Silver sheen
Eyeball diameter to total length ratio (E:L)	Largest for parr	Ratio decreasing from parr	Ratio decreasing from transitional

Table E2.--Visual characteristics of coho salmon for stages of smoltification in seawater.

	Parr	Transitional	Smolt
Color	Brown dorsally, yellow-gray ventrally with prominent mottled appearance	Greenish dorsally, cream to white ventrally	Metallic blue dorsally, white to silver ventrally
Parr marks	Generally boldly evident	Partially visible	Absent
Condition	Robust to gaunt	Robust to slender	Not as slender as freshwater smolt
Pectoral fins	Yellow-brown to orange	Clear to yellow	Clear with black pigment between rays
Ventral fins	Yellow-brown to orange	Clear to yellow	Clear
Anal fin	Yellow-brown to orange, often with white-tip	Clear to yellow with some black pigment between the rays	Clear with black pigment between the rays
Caudal fin	Yellow-brown to orange	Clear to yellow	Clear, black pigment on posterior margin
Adipose fin	Translucent brown	Translucent green	Translucent blue with black margin
Dorsal fin	Translucent brown	Translucent green, spotted	Translucent blue, spotted with black pigment on margin
Opercle	Golden sheen	Bronze sheen	Silver sheen
Eyeball diameter to total length (E:L)	Largest for parr	Ratio decreasing from parr	Ratio decreasing from transitional

Physiological and Morphological Measurements

Results and discussion of the physiological and morphological measurements will be presented in an addendum to this report upon completion of the work.

REFERENCES

Clarke, W. C., and J. Blackburn.

1977. A seawater challenge test to measure smolting in juvenile salmon. Dept. Environ. Fish. Mar. Serv. Res. Div. Dir., Tech. Rpt. No. 705, 11 pp.

Dickhoff, W. W., L. C. Folmar, and A. Gorbman.

1978. Changes in plasma thyroxine during smoltification of coho salmon, (Oncorhynchus kisutch). Gen. Comp. Endocr. 36:229-232.

Smith, C. E., and R. G. Piper.

1975. Lesions associated with chronic exposure to ammonia. pp. 497-514. IN W. E. Ribelin and G. Migaki, eds. The Pathology of Fishes University of Wisconsin Press, Madison.

Zaugg, W. S., and L. R. McLain.

1970. Adenosinetriphosphatase activity in gills of salmonids: seasonal variations and saltwater influence in coho salmon, Oncorhynchus kisutch. Comp. Biochem. Physiol. 35:587-596.

APPENDIX F

GREEN RIVER COHO SALMON SIZE-DENSITY STUDY

by

Kurt X. Gores

Earl F. Prentice

INTRODUCTION

A salmon's early rearing environment (water temperature, water flow, loading density, feeding strategies, etc.) influences the quality of fish released and therefore their contribution and escapement.

To determine the effect of raceway loading density on growth, survival, and potential gains from releasing larger numbers of smaller coho salmon smolts, a study was conducted by the Washington Department of Fisheries (WDF) at their Green River Hatchery. The National Marine Fisheries Service (NMFS) participated in the study to monitor the smoltification process using biochemical criteria [gill $\text{Na}^+\text{-K}^+$ ATPase, plasma electrolytes, triiodothyronine (T_3), and thyroxin (T_4)].

METHODS AND MATERIALS

Juvenile coho salmon from a 1978 brood were transferred to eight 3.1-x 23.5-x 1.2 m deep (87.4 m^3) concrete raceways at the Green River Hatchery in May 1979. The inflow to each raceway was fixed at 2271 liters per minute. During the course of the study, water temperature ranged from 1.1° to 20°C . Fish were reared for release to two sizes (33/kg and 55/kg) at four loading densities per size group (Table F1). Size at release was controlled by adjusting feeding schedules. Raceway loading was increased by 10% as an allowance for loss during the test period. Five percent of the population in each raceway was tagged with coded wire tags (CWT) (Table F1).

Each raceway was sampled by NMFS personnel on a biweekly basis from 14 February to 21 April 1980 to monitor gill $\text{Na}^+\text{-K}^+$ ATPase, T_3 , T_4 , and five plasma electrolytes (Na^+ , Cl^- , K^+ , Mg^{++} , Ca^{++}). Sampling and analysis techniques are described in CZES and ETSD 1979 and Prentice et al. 1980.

INTRODUCTION

Table Fl.--Raceway loading densities during rearing and sizes at release of coho salmon in Green River study.

Group	Fish loading density			Size of fish		Tag identification code
	Initial (kg/m ³)	Final (kg/m ³)	Projected (kg/m ³)	Projected at release (No./kg)	Actual at release (No./kg)	
1	0.0019	0.020	0.022	55	54	63-18-62
2	0.0018	0.018	0.019	55	56	63-18-63
3	0.0014	0.016	0.017	55	55	63-19-01
4	0.0013	0.014	0.014	55	53	63-24-21
5	0.0014	0.020	0.026	33	41	63-21-18
6	0.0013	0.019	0.023	33	40	63-21-17
7	0.0010	0.019	0.020	33	33	63-21-16
8	0.0009	0.014	0.016	33	38	63-21-15

Personnel of the WDF maintained feeding, environmental (e.g., water temperature), growth, and mortality records. Bulk weights were taken biweekly from each raceway to establish growth profiles.

RESULTS AND DISCUSSION

Fish were scheduled for release on 1 May 1980; however, low dissolved oxygen in the raceways required early release on 23 April.

A problem with silting in the outflow end of the raceways was encountered toward the end of the study. Final density calculations, however, were based on unsilted raceway dimensions.

A furunculosis, Aeromonas salmonicida, outbreak in June 1979 affected fish in all of the raceways. The initial high mortality, in part, prevented achieving projected loading densities (Table F1); however, this mortality was not density related. Following the losses in June, mortality stabilized and remained nominal until release. Overall losses from disease and unaccountable loss ranged from 10.2 to 18.0%.

Gill $\text{Na}^+\text{-K}^+$ ATPase levels remained low (3.7-15.3 $\mu\text{ moles} \cdot \text{P}_i$ $\text{mg protein}^{-1}\cdot\text{h}^{-1}$) throughout the study. The narrow range in final density (0.014 - 0.020 kg/m^3) prevented analysis of any density effect on gill $\text{Na}^+\text{-K}^+$ ATPase levels. There were no significant differences in gill $\text{Na}^+\text{-K}^+$ ATPase activity between size groups when transferred to seawater. The data were analyzed using the Students t-test ($\alpha = 0.05$). Gill $\text{Na}^+\text{-K}^+$ ATPase activities showed a general upward trend as smoltification began but did not reach a peak before the fish were released.

The patterns of plasma T_4 in the eight test groups are shown in Figure F1. Groups 1 through 4 had final mean fork lengths of 118 to 121 mm and mean body weights ranging from 18 to 19 g. Groups 5 through 8 had

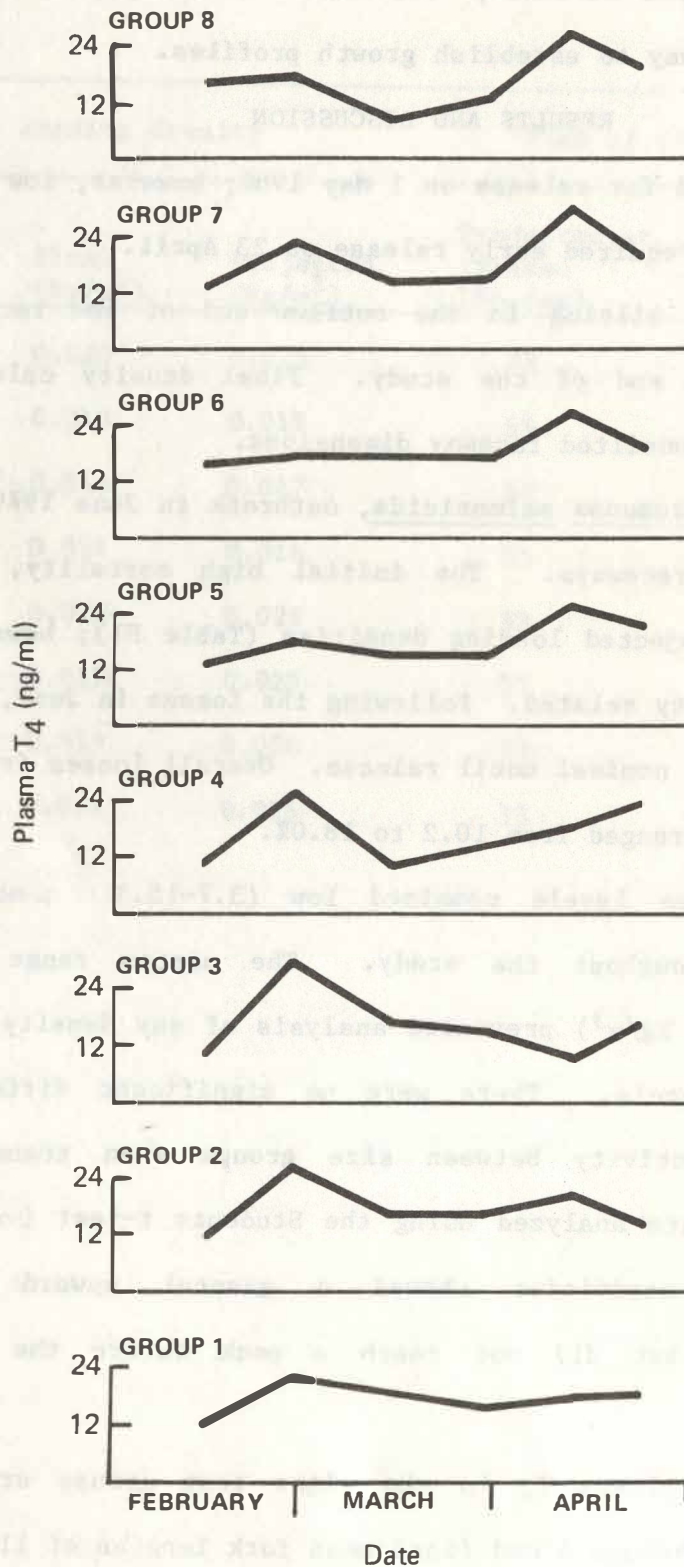

Figure F1.--Plasma T₄ profiles for eight test groups of yearling coho salmon (see Table F1).

final mean fork lengths of 128 to 134 mm and body weights averaging 24 to 27 g. Plasma T_4 levels of the small fish showed either no change (Groups 1 and 2) or slight increases during April (Groups 3 and 4). Distinct springtime peaks in plasma T_4 were not observed in any of the small fish during the sampling period. Plasma T_4 levels of the large fish (Groups 5 through 8) showed increases during April, with peaks at mid-April. Plasma T_4 declined by late April in all of the large fish.

The larger fish test groups (Groups 5-8) showed distinct springtime plasma T_4 peaks toward the end of the sampling period. However, they did not return to basal levels before they were released. Previous studies have suggested that coho salmon are functionally smolted when plasma T_4 levels peak and return to basal values (CZES and ETSD 1979, Appendix E; Prentice et al. 1980, Appendix F). Distinct springtime T_4 peaks did not occur in the small fish (Test Groups 1 through 4). These data suggest that the development of the small fish was delayed compared to the large fish, and that small juvenile coho salmon should be released at a later date than large smolts. The peculiar occurrence of an elevation of plasma T_4 in the small fish during late February remains unexplained. It is doubtful that this elevation could be associated with the parr-smolt transformation since it occurred so early.

Previous studies (Dickhoff et al. 1981) have shown that T_3 appears to be a useful measurement for predicting seawater adaptability of subyearling coho salmon but not yearling fish. Consequently, T_3 data are not presented or discussed.

The studies on plasma concentrations of sodium, potassium, chloride, and magnesium showed no consistent changes which could be used to evaluate the smoltification status of juvenile coho salmon. Plasma calcium levels

showed an increase during the parr-smolt transformation. Recent studies, however, indicate that stresses which lower the acidity of fish blood cause a rapid elevation of calcium levels (Ruben 1981). This rapid blood hypercalcemia induced by stress makes plasma calcium concentrations of questionable value in assessing smolt status. A similar stress-related effect on plasma potassium levels was also observed in our studies. Therefore, data for these plasma ions are not presented or discussed.

In conclusion, an insufficient level of smoltification at release may affect survival and therefore reduce any differences in contribution related to size at release. Projected sizes at release were nearly reached or exceeded in all raceways (Table F1). Any benefit from releasing larger numbers of smaller coho salmon will not be observed, however, until contribution and escapement data are analyzed. As noted before, the incidence of smoltification, determined by gill $\text{Na}^+\text{-K}^+$ ATPase activity, was similar between test groups (low) at the time of release. We would therefore not expect a high contribution by any of the test groups based on this criterion alone. Plasma T_4 concentrations, however, for Groups 5-8 peaked at the end of April and were returning to basal levels. This suggests that these fish may perform well in seawater. These conclusions may be modified if the fish remained in the river system after release and continued their smoltification or continued to smolt once in seawater.

REFERENCES

Coastal Zone and Estuarine Studies Division and Environmental and Technical Services Division.

1979. A study to assess status of smoltification and fitness for ocean survival of chinook, coho, and steelhead. Project 817. Coastal Zone and Estuarine Studies Division, Northwest and Alaska Fisheries Center, 403 p. (Processed).

Dickhoff, W. W., L. C. Folmar, J. L. Mighell, C. V. W. Mahnken, and A. Gorbman.

1981. Thyroid hormones in smoltification of anadromous salmonids. Proc. North Pacific Aquaculture Symp., Newport, Oregon, August 26, 1980.

Prentice, E. F., C. Mahnken, K. Gores, W. Waknitz, L. Folmar, R. King, J. Mighell, W. Dickhoff, T. Flagg, L. Harrell, A. Novotny, D. Damkaer, E. Wold, and R. Vreeland.

1980. A study to assess status of smoltification and fitness for ocean survival of chinook and coho salmon and steelhead. Project 10990060. Coastal Zone and Estuarine Studies Division, Northwest and Alaska Fisheries Center, 408 p. (Processed).

Ruben, J. A.

1981. Exercise induced hypercalcemia in vertebrates. Proc. Western Reg. Conf. Comp. Endocrinol., Corvallis, Oregon.

PART II

SUMMARY AND RECOMMENDATIONS

INTRODUCTION

Catches of the five Pacific salmon species (chinook, coho, sockeye, chum, and pink) have declined significantly since the record levels of the early 1900's. Habitat destruction and overfishing have been major causes of the decline. To reverse this trend, the states, federal government, and Indian tribes have undertaken artificial propagation programs. These programs have enjoyed unparalleled success in providing fish for a large segment of the U.S. salmon fishery. In 1960, there were 72 facilities producing salmon and steelhead on the Pacific Coast. By 1976, the number of facilities had more than doubled to 154. Annual juvenile migrant production of all species increased from 152 million fish in 1960 to 294 million fish in 1976. Altogether, 3.44 billion migrants, weighing over 47.6 million kg, were released during this period (Wahle and Smith 1979).

The Columbia River Basin is unique in the number of hatcheries constructed as compensation for habitat destroyed by water-use projects. The five state and federal fish management agencies in this region account for 54% of the total numbers of Pacific Coast anadromous fish releases. Likewise, the salmon fishery of the Boldt Case Area^{1/} is highly dependent on artificial propagation to provide fish for recreational and commercial user groups. This area produces nearly 30% of the Pacific Coast anadromous fish releases (Wahle and Smith 1979).

^{1/} Case Area is defined as that portion of the state of Washington west of the Cascade Mountains and north of the Columbia River drainage area, and includes the American portion of the Puget Sound watershed, the watersheds of the Olympic Peninsula north of the Grays Harbor watershed, and the offshore waters adjacent to those areas. During 1977, the case area was expanded to include all of Grays Harbor for the Quinault Indian Tribe pending further consideration.

Today, more than ever, the pressure is on Pacific Northwest fisheries agencies to provide additional fish to the various user groups. The Washington Department of Fisheries (WDF) alone is planning the construction of 28 new rearing facilities (ponds and hatcheries) under the legislative authority of third substitute HB 1188 (Chapter 327, Washington Laws of 1977, First Ex. Ses.). Terms of the recent Boldt settlement plan call for an even larger program of increased natural and artificial production to increase landings in the case area (Merkel et al. 1978).

There is little doubt that properly planned enhancement programs will contribute significantly to increased runs of salmon and steelhead. However, expanded artificial propagation must not be considered a panacea for all fishery problems in the Pacific Northwest. It has been recognized by fishery agencies that the release of hatchery smolts which are better fitted for seawater survival may produce the same results as increased production, and at far lower cost than required to construct and operate new hatcheries.

One of the primary factors affecting the contribution of hatchery fish to the fishery is mortality of juveniles shortly after their release. Mortality rates are dependent on many factors, including the adaptability of the fish to river, estuarine, and ocean environments. Hatchery rearing environments and husbandry techniques such as feeding strategy, rearing temperature, stocking density, and disease treatment play important roles in determining adaptability and survival.

Hatchery propagation programs typically place emphasis on numbers of fish produced; survival in the hatcheries; and fish size, health, and

external appearance at release. The release dates for hatchery fish are often based on limited biological criteria or tradition. Many of these fish are not ready to outmigrate and thus use the river and estuary as a post-release rearing area where they are subjected to a number of adverse biological and environmental factors.

In March 1978, the National Marine Fisheries Service (NMFS) and the Pacific Northwest Regional Commission (PNRC) initiated a 3-year cooperative study to determine the factors which may affect smoltification, ocean survival, and adult returns of anadromous salmonid stocks from hatcheries on the Columbia River and its tributaries. This project, because of financial limitations, was funded for only 2 years by PNRC. The final year of the study was financed by Saltonstall-Kennedy (SK) funds. The study had the following primary objectives:

1. Determine the status of smoltification using gill $\text{Na}^+\text{-K}^+$ ATPase activity, plasma thyroid hormone concentrations, and plasma electrolyte concentrations in fish prior to their release from selected hatcheries.

2. Compare biochemical measures (see Number 1 above) with traditional morphological and behavioral characteristics to determine smoltification at the hatcheries.

3. Determine the seawater adaptability of fish from some of the same hatcheries by monitoring growth, mortality, and reversion to parr in the seminatural conditions of seawater net-pens in Puget Sound.

4. Ascertain the general health profile of each stock at the time of smoltification, immediately prior to hatchery release, and during natural outmigrations in the river and estuary.

During the 1978-81 study period, 135 groups of fish from 27 state and federal hatcheries were evaluated (CZES and ETSD 1979, and Prentice et al. 1980). Target species included coho salmon, spring and fall chinook salmon, and steelhead. Selection of test groups was coordinated with the Oregon Department of Fish and Wildlife (ODFW), WDF, Washington Department of Game (WDG), and the U.S. Fish and Wildlife Service (USFWS).

High priority was given to tagged groups in existing or planned evaluation programs, two separate stocks grown under the same environmental conditions, one stock grown at two different hatcheries, or stocks exhibiting unique characteristics of growth and adult survival. The use of tagged fish made it possible to identify the fish in the NMFS Columbia River sampling program at Jones Beach (Rkm 76), thereby enabling data gathered at the hatcheries to be related to outmigration (Dawley et al. 1980).

The following is a summary of the 3 years of work performed by NMFS. Results of studies unique to FY 1980-81 are not repeated. The information gathered during the study is subject to further evaluation and most conclusions remain preliminary.

SUMMARY

Gill Na^+-K^+ ATPase Activities in Salmonids as Related

to Parr-Smolt Transformation and Migration

The activity of Na^+-K^+ ATPase, an enzyme involved in the regulation of cellular and blood levels of sodium, increases dramatically in gill tissue of salmonids during seawater acclimation as the requirement develops to eliminate accumulating salt in body tissues and fluids. Increases in activity of this enzyme can also be detected during parr-smolt transformation in several anadromous salmonid species, and are used to indicate when smoltification occurs. During the past 3 years our studies have attempted to define relationships between increases observed in gill Na^+-K^+ ATPase activity and other phenomena associated with smoltification such as visual silvering, increased seawater tolerance, and development of downstream migratory behavior.

Hatchery populations of coho salmon and steelhead experience elevated gill Na^+-K^+ ATPase activity at least during one period in the spring (increases possibly occur at other times under special conditions). The occurrence of elevated activity may vary over a 30-day span from year to year at a particular hatchery depending upon several factors. The period during which enzyme activity remains elevated is subject to environmental conditions such as water temperature and crowding, but is of finite duration. If coho salmon or steelhead are retained in fresh water, enzyme activity decreases to pre-smolt levels at least by late June (summer solstice) or early July. Chinook salmon, on the other hand, if confined to ponds and not allowed to migrate, may experience more than one period of elevated activity during the year. Yearling (age 1+) spring chinook salmon

generally show a spring increase in activity, whereas subyearlings (0-age) may develop increases in the fall. Subyearling fall chinook salmon have shown peaks in March and May, and if held at the hatchery, increase again as yearlings in September and October. Peaks of gill Na^+-K^+ ATPase activity in fall chinook salmon may occur at different times from one year to another in a given hatchery population. The reason for such variation is not well understood, but size, growth rates, and water temperature are probably important factors.

The following observations have been made:

1. Active seaward migrants of all species examined (steelhead, coho salmon, and fall and spring chinook salmon) developed higher gill Na^+-K^+ ATPase activities than fish held in the hatchery. Many migrants obtained in the lower Columbia River (Jones Beach) had gill Na^+-K^+ ATPase activities equal to fish which were completely adapted to seawater.

2. Coho salmon held in the hatchery through a period of elevated gill Na^+-K^+ ATPase activity (May) until that activity declined to pre-smolt levels (June and July) were capable of rapidly redeveloping high activities after liberation. These fish (released in June and July) migrated seaward more rapidly than fish released in May (peak gill Na^+-K^+ ATPase activity at hatchery). Preliminary data on ocean catches and hatchery returns show greater survival for fish released in June.

3. Populations of fall chinook salmon released prior to major elevations in gill Na^+-K^+ ATPase activity show mixed migratory behavior. Some fish migrate immediately; whereas others may delay several weeks or months. Releases made during and following the development of major peaks in gill Na^+-K^+ ATPase activities result in rapid seaward migration of the total population, unless the release is made in late fall.

4. Gill $\text{Na}^+\text{-K}^+$ ATPase activities increase in fall chinook salmon receiving salt-supplemented diets (7 - 8% NaCl, dry wt.). Greater survival of fish fed these diets for 6 weeks prior to seawater entry indicates that dietary salt can aid in seawater acclimation.

5. Two genetically different stocks of yearling spring chinook salmon reared under the same conditions at the same hatchery showed greatly different rates of gill $\text{Na}^+\text{-K}^+$ ATPase increase in the spring.

Determination of gill $\text{Na}^+\text{-K}^+$ ATPase activity is a valuable tool in assessing the smolt condition of anadromous salmonids. The activity of this enzyme should be high at time of seawater entry to minimize osmoregulatory stress accompanying adaptation. High levels of activity in migrating smolts suggest that, under natural conditions, seawater entry occurs after the enzyme activity is well developed. Data now being accumulated on patterns of gill $\text{Na}^+\text{-K}^+$ ATPase development in hatchery-reared salmonids, release times, rates of seaward migration, and adult contribution, will enable fishery managers to use gill $\text{Na}^+\text{-K}^+$ ATPase information in timing releases for maximum survival.

Thyroid Hormone and Blood Ion Changes in

Coho Salmon during Smoltification

Initially, we found there were concomitant increases in gill $\text{Na}^+\text{-K}^+$ ATPase and plasma concentrations of thyroxine (T_4) during smoltification (Figure 1). In accordance with previous findings in mammals, we speculated that gill $\text{Na}^+\text{-K}^+$ ATPase activities of fish were from the influence of increased plasma levels of T_4 . Subsequent experiments have shown that the gill $\text{Na}^+\text{-K}^+$ ATPase and T_4 peaks are not interdependent events, but probably represent simultaneous

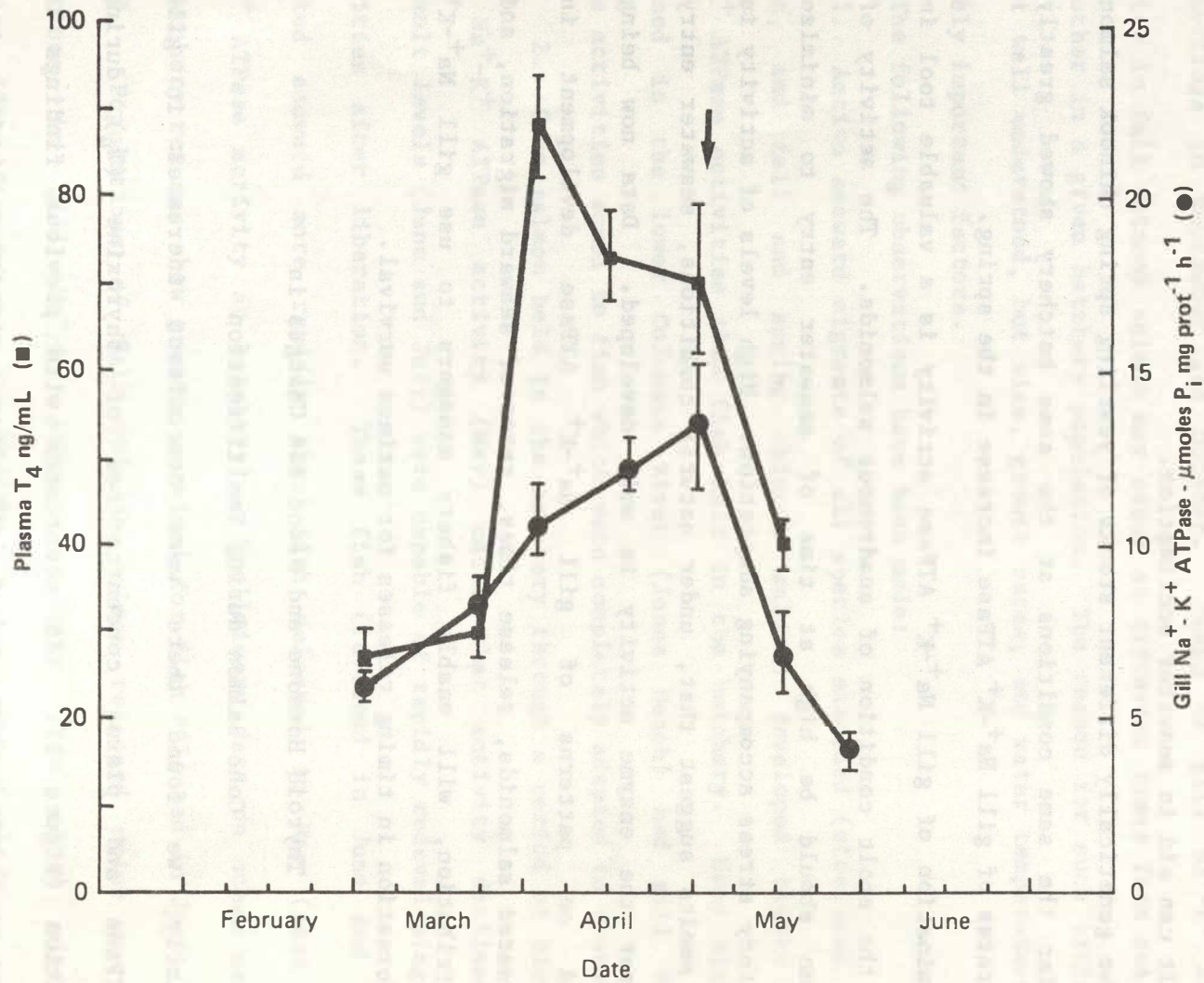

Figure 1.--Plasma T₄ concentrations and Na⁺-K⁺ ATPase activity vs time for coho salmon during smoltification in fresh water.

neuroendocrine responses to changes in the environment of the fish (i.e., increasing water temperature, lengthening photoperiod, and lunar periodicity).

Plasma thyroid hormone levels of coho salmon entering seawater on the upward side of the curve fall precipitously at seawater entry, and their growth is "stunted" at that point. The greatest survival of coho salmon resulted when fish were transferred to seawater when 65-85% of the T_4 curve was complete. This optimal period could be extended when the thyroid pulse was completed prior to the summer solstice. Unlike coho salmon, chinook salmon and steelhead transferred to seawater under suboptimal conditions die rather than become "stunted".

Changes in plasma levels of thyroid hormones can easily be quantified by radioimmunoassay. We have demonstrated that a quantitative analysis of the thyroid pulse provides an estimator of the optimal time to transfer fish to seawater. This predictive index is particularly applicable when smolts are directly transferred to seawater (ocean ranching, net-pen farming); however, we have yet to determine the best time to release fish from a hatchery so that they arrive at the estuary at the optimal point on the T_4 curve. This will require additional study regarding the riverine and migratory influence on the thyroid cycle.

Changes in plasma electrolytes (Na^+ , K^+ , Cl^- , Ca^{++} , and Mg^{++}) were evaluated for 2 years in several stocks of fish in both fresh water (Figures 2 and 3) and seawater (Figure 4). There were no significant changes in Na^+ , Cl^- , or Mg^{++} . Although the mean values of K^+ and Ca^{++} appeared to change slightly, we believe the changes were stress related as a function of the time required to sample the 30 fish in each

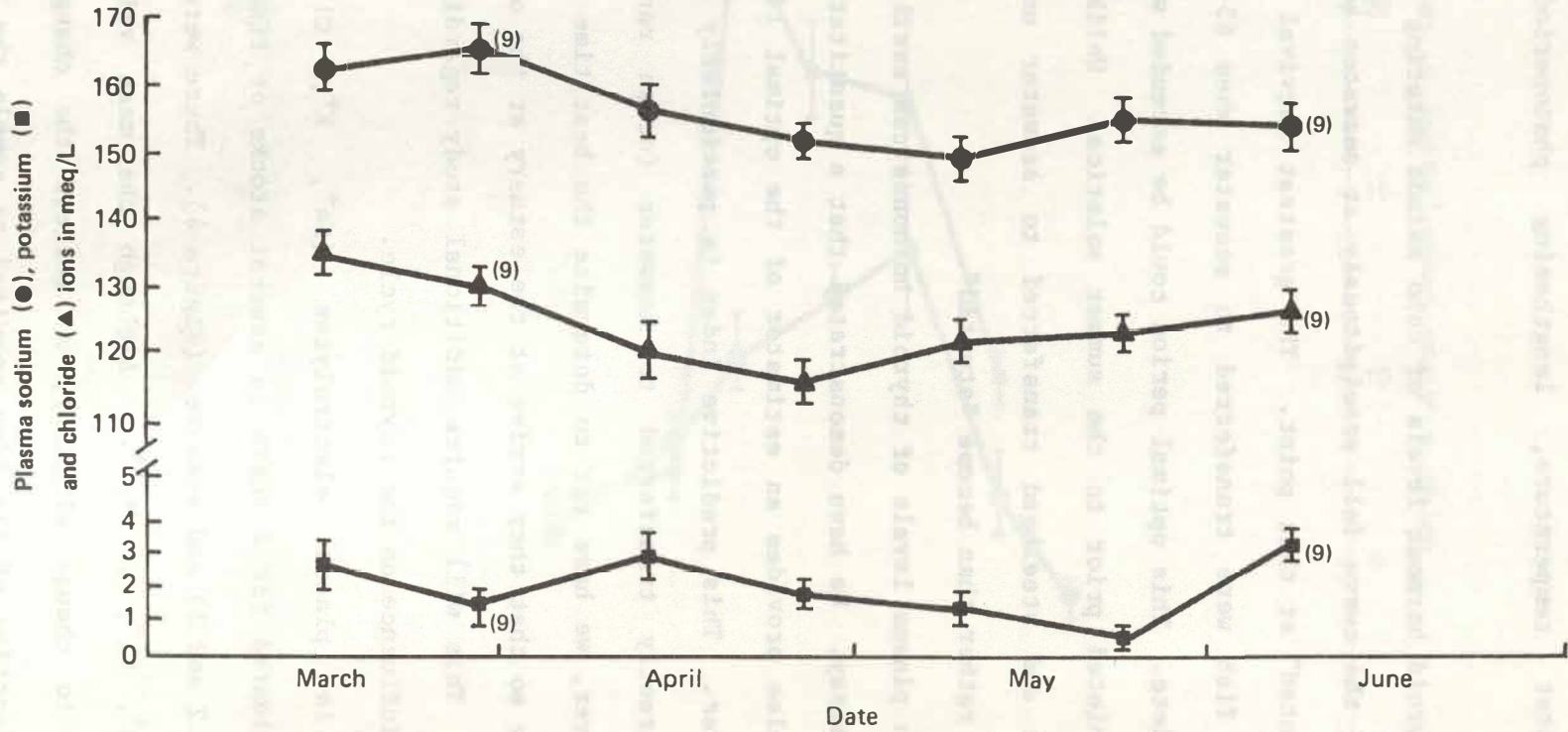

Figure 2.--Plasma electrolyte (Na^+ , K^+ , Cl^-) levels in coho salmon in fresh water. Numbers in parentheses indicate a sample size other than ten.

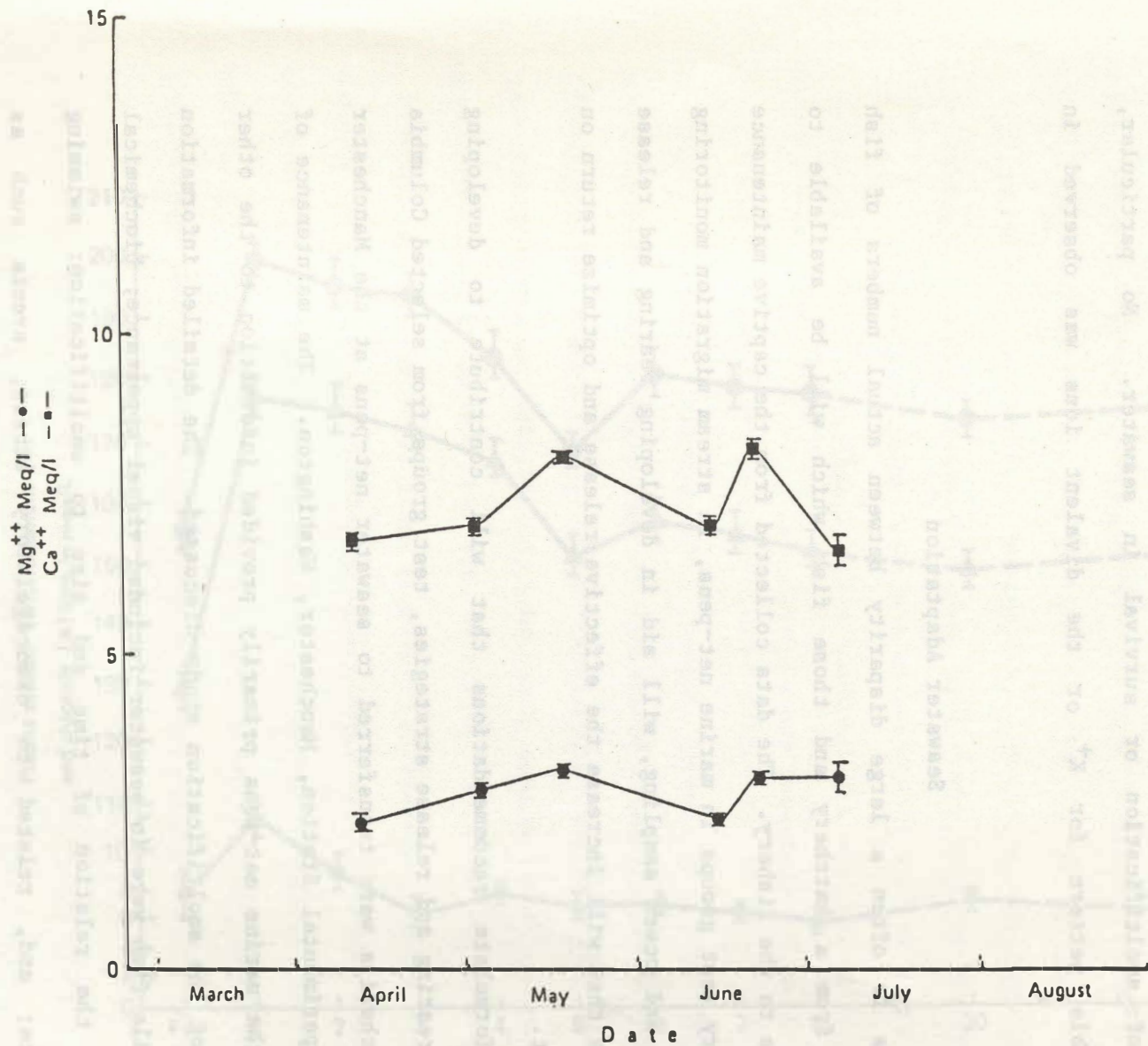

Figure 3.--Plasma electrolyte (Mg⁺⁺, Ca⁺⁺) levels in coho salmon in fresh water.

sampling group. Plasma levels of both Na^+ and Cl^- increased at seawater entry, remained elevated for 24-72 hours, then decreased to levels commensurate with seawater residence (Figure 4). Although these increases occurred in all of the stocks of fish examined, no mathematical relationships were found between the plasma levels of Na^+ or Cl^- and success of smoltification or survival in seawater. No particular, reproducible pattern for K^+ or the divalent ions was observed in seawater.

Seawater Adaptation

There is often a large disparity between actual numbers of fish released from a hatchery and those fish which will be available to contribute to the fishery. The data collected from the captive maintenance of hatchery test groups in marine net-pens, in stream migration monitoring programs, and ocean sampling, will aid in developing rearing and release strategies that will increase the effective release and optimize return on investment.

To formulate recommendations that will contribute to developing hatchery rearing and release strategies, test groups from selected Columbia River hatcheries were transferred to seawater net-pens at the Manchester Marine Experimental Station, Manchester, Washington. The maintenance of fish in the marine net-pens primarily provided information to the other elements of the smoltification study discussed. The detailed information gained while fish were in seawater included visual appearance; biochemical activity; the relation of time and size to smoltification; swimming performance; and, related to osmoregulatory stress, events such as stunting, reversion from a smolted to a non-smolted condition, and death.

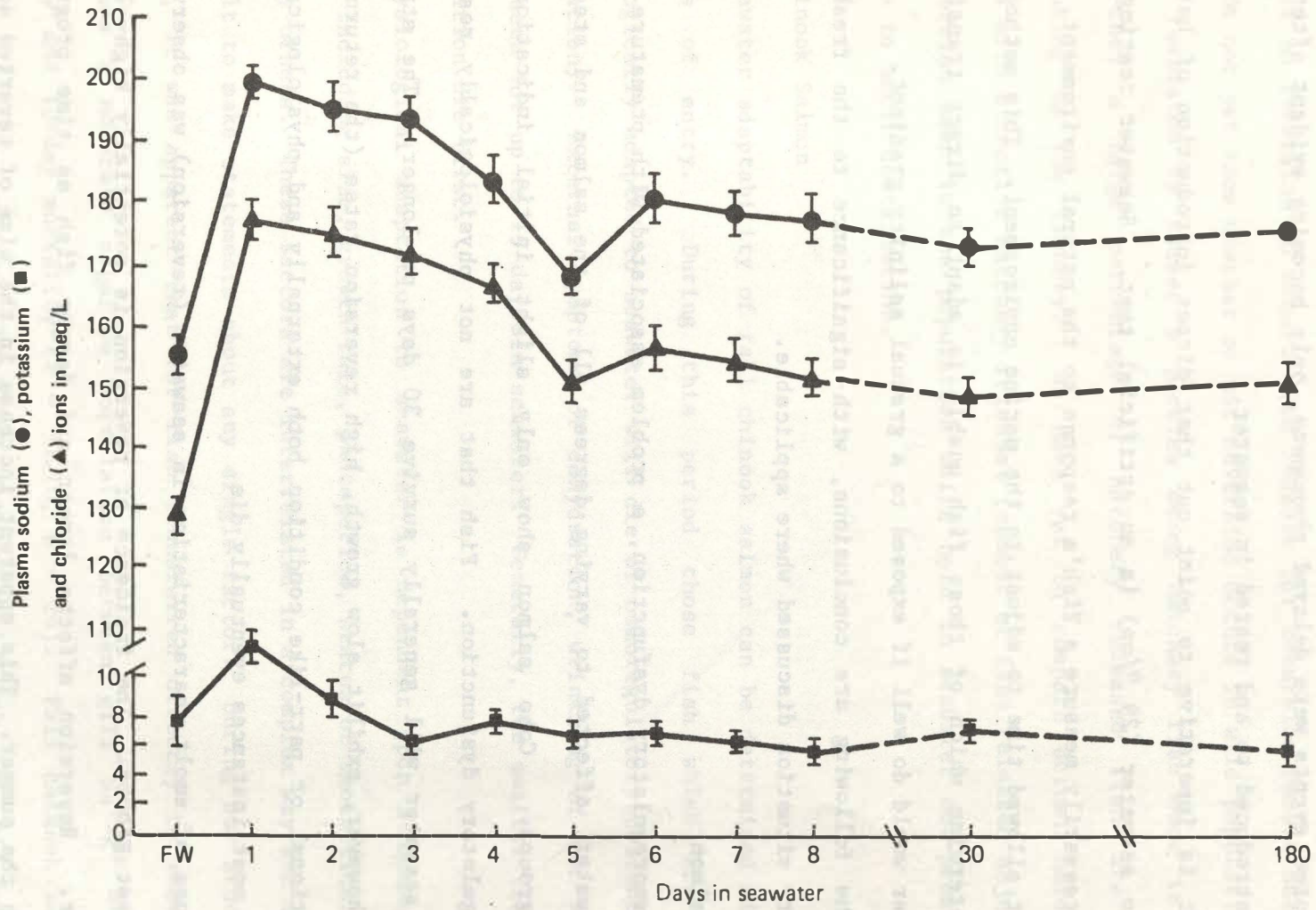

Figure 4.--Plasma electrolyte (Na^+ , Cl^-) levels in coho salmon after transfer to seawater.

In addition, the evaluation of latent freshwater pathogenic organisms on marine survival and/or smoltification was facilitated. Many of the documented events were delayed phenomena, only becoming evident after fish were introduced to and reared in seawater.

It is imperative to point out that direct introduction of hatchery fish to seawater (29 ‰) is an artificial test. Seawater testing does not necessarily measure a fish's response to the natural environment. Fish are not allowed time to adjust to the marine environment. This method does not determine which of those fish unable to adapt to direct transfer to seawater would do well if exposed to a gradual salinity gradient.

The following are conclusions, with significance to the freshwater hatchery situation discussed where applicable.

Coho Salmon

Osmoregulatory dysfunction, a problem associated with premature entry to seawater, affected to varying degrees all of the salmon and steelhead test groups. Coho salmon show only slight initial indications of osmoregulatory dysfunction. Fish that are not physiologically ready to enter seawater will generally survive 30 days or longer. The stressed fish, however, exhibit slow growth, high reversion rates (the return to a transitional or parr-like condition both externally and physiologically), and in most instances eventually die.

Loss of smolt characteristics in seawater (reversion) was observed in most test groups. The incidence of reversion is potentially high--70% or greater. Reversion affects larger and larger fish as time progresses through the summer. This apparent increase in the size of reverted animals continues even after the summer solstice. The size of the largest parr in

seawater populations may indicate the size which must be exceeded by smolts to avoid reversion. Figure 5 shows the minimum size a population must reach for no reversion to occur. The reasons for reversion remain unknown and we do not yet know whether or not reversion occurs in wild populations.

If reversion is indeed a problem among hatchery fish once in the ocean, then a large percentage of hatchery released fish are not contributing to the fishery. We have yet to compare actual hatchery releases with effective hatchery releases (number of fish released adjusted for reversion seen in the population while held in seawater net-pens) in relation to adult contribution.

Fall Chinook Salmon

Seawater adaptability of fall chinook salmon can be determined within 15 days of entry. During this period those fish which are not physiologically adapted to seawater will die of osmoregulatory dysfunction (dehydration). External symptoms of dehydration, wrinkling of the skin, can be seen for up to 15 days in seawater. Generally, the smaller fish in a population die first.

Physiological adaptation to seawater is dependent upon a number of factors including size, growth rate, photoperiod, status of smoltification, and many others. These factors are interrelated in a complex way and it is difficult to make statements about any single factor. During our studies, however, it was apparent that for fish transferred directly to seawater there was a moderate negative correlation between gill Na^+-K^+ ATPase activity and 10-day mortality ($r = -0.70$, $n = 26$). Fall chinook salmon directly entering seawater (29 ‰) between mid-March and mid-August, with gill Na^+-K^+ ATPase activity levels above 10.0 moles Pi mg

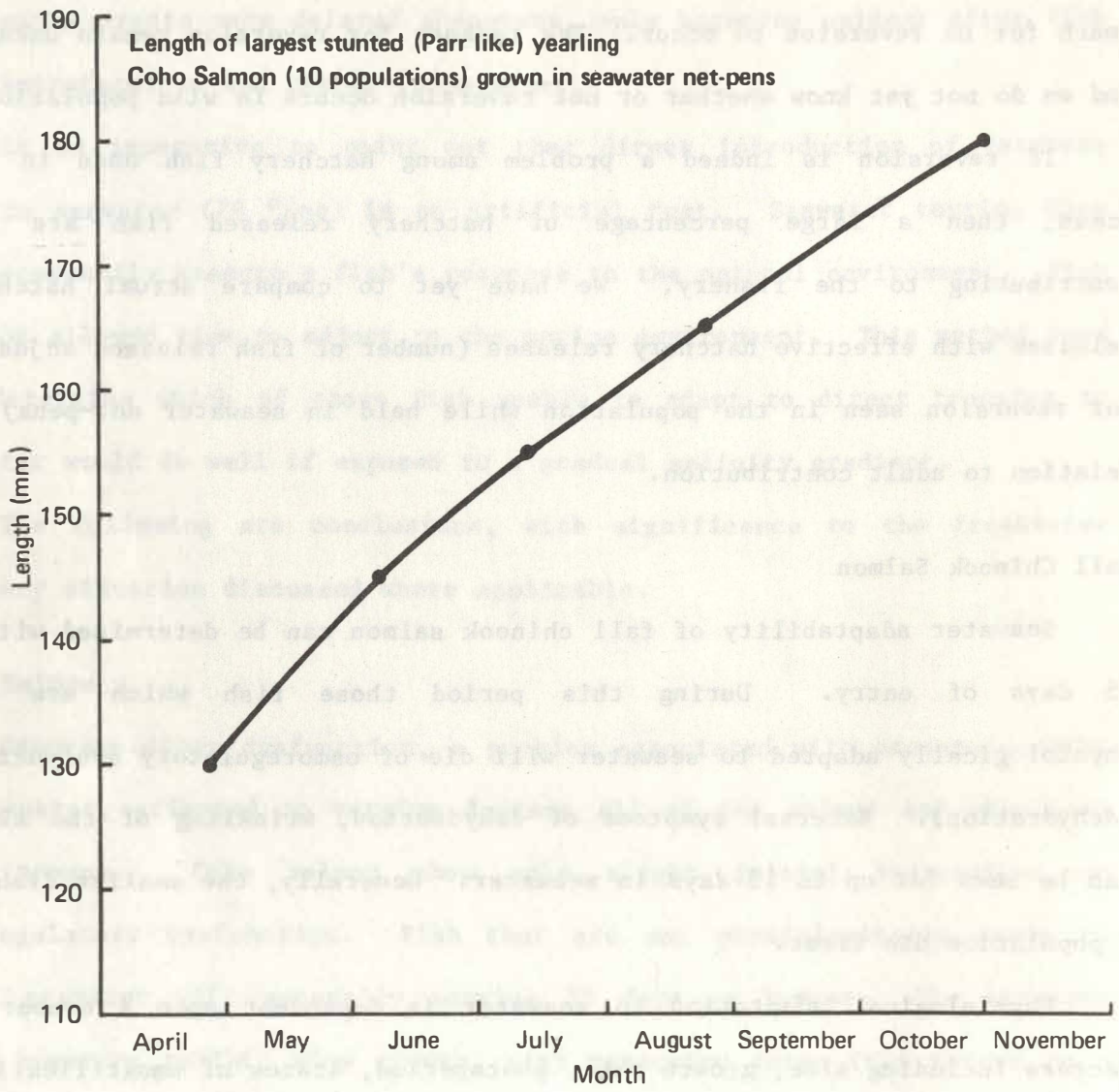

Figure 5.--Minimum size (length) of coho salmon vs time for successful adaptation to seawater.

$\text{Prot}^{-1} \cdot \text{h}^{-1}$, showed less post seawater entry stress (<10% 10-day mortality) than other entry groups (up to 50% 10-day mortality). Mortality after the initial 10-15 days in seawater was caused by vibriosis.

It must be emphasized again that direct seawater entry can give very different results than releasing fish into a stream system. Some hatchery populations of fall chinook salmon may show no physiological signs of smoltification (low gill $\text{Na}^{+}\text{-K}^{+}$ ATPase activity, visible parr marks, etc.) yet when released into a river, a certain percentage of this population is capable of undergoing transformation to smolts and migrating rather quickly downstream. The migrants develop elevated levels of gill $\text{Na}^{+}\text{-K}^{+}$ ATPase and silvery coloration typical of smolts. Others of the same population remain in the river and may delay migration up to several weeks. Fish released from the Kalama Falls Hatchery showed this kind of behavior as did some fish released from Spring Creek National Fish Hatchery (NFH). Generally, a higher percentage of populations of fall chinook salmon which have elevated gill $\text{Na}^{+}\text{-K}^{+}$ ATPase activities migrate rapidly downstream and remain less time in the river. One implication of this is that fish which hold over and do not migrate to sea directly from the streams in which they were liberated may not imprint on home waters, but rather on waters in which they smolt and begin active seaward movement. If this is true then many surviving holdovers may not return to their hatchery of origin.

Unlike spring chinook salmon, few precocious males were observed in the test groups at time of seawater entry or during seawater rearing. A possible explanation for this difference could be the limited exposure to the hatchery environment when compared to spring chinook salmon. As will

be pointed out, hatchery environmental conditions have been shown to influence the incidence of precocity. Extended hatchery rearing of fall chinook salmon may increase the incidence of precocity and thus reduce the effective hatchery release.

Spring Chinook Salmon

A high percentage of precocious males was observed in most test groups. These fish were initially the larger fish in the population but grew little after exhibiting early sexual development and eventually died after several months of seawater exposure (Table 1). The percent of precocious fish varied with time within a test population. No consistent pattern was seen in either the percent of precocious males or the time of observed precocity among fish from the same hatchery from year to year.

The cause of precocity is not fully understood, however husbandry practices and genetic and environmental factors are known to be influential (Hershberger^{2/}). Since precocious chinook salmon males do not contribute to the fishery, yet can make up a large portion of the population, an effort should be made to identify specific factors that influence this early maturation. By identifying and eventually controlling the factors influencing precocity, the number of fish contributing to the fishery could be increased.

Initial seawater adaptability was different between spring chinook salmon entering seawater in the fall (0-age) and spring (yearling). The fall entry groups consisted primarily of parred fish (visual criteria) which showed a high mortality rate within the first 15 days of seawater

^{2/}William Hershberger, University of Washington, College of Fisheries, Seattle, Washington 98195, pers. commun.

Table 1.--Maximum percent precocious males in test groups of spring chinook salmon observed in seawater net-pens.

Hatchery	Date of seawater entry	Population size at start (n)	Date of maximum % precocity	Population size at time of observation (n)	Maximum ^{a/} percent precocious males
Carson NFH	4-21-77	300	6-27-77	188	13.8
Carson NFH ^{b/}	9-20-77	150	7-19-78	34	5.9
Carson NFH ^{b/}	11-16-77	150	6-07-78	221	1.5
Carson NFH	5-02-78	300	6-06-78	120	9.5
Carson NFH	5-02-79	200	7-17-79	74	14.9
Kalama Falls	3-10-77	312	8-03-77	96	7.3
Kalama Falls	3-03-78	300	6-07-78	221	0.9
Leavenworth	4-23-78	296	8-23-78	247	8.9
Leavenworth	4-26-79	200	6-06-79	182	7.0
Eagle Creek	5-02-77	300	5-26-77	297	12.8
Kooskia	4-26-78	180	8-22-78	89	2.2

a/ Percent precocious males at time of observation.

b/ Introduced to seawater during first year of life (0-age).

residence (osmoregulatory dysfunction) and had low or nondeveloping freshwater gill $\text{Na}^+\text{-K}^+$ ATPase activity. This was in contrast to spring entry groups which consisted mainly of transitional and smolted fish (visual criteria), exhibited a low initial mortality rate, and had a developing or well developed freshwater gill $\text{Na}^+\text{-K}^+$ ATPase pulse at time of seawater entry. It should be noted that the differences between fall and spring entry groups to seawater are based upon limited fall entry data (three out of twenty test groups evaluated). It is recommended that further research be conducted to better define the differences.

There were some similarities between the fall and spring seawater entry groups. Within 15 days after seawater entry, the smaller fish in a population were the first to die, primarily from osmoregulatory dysfunction. Also, some fish initially showing parr or transitional characteristics were able to smolt (visual criteria) in seawater.

Steelhead

Many steelhead test groups had freshwater histories of bacterial and viral diseases at the time of seawater entry. The ability of these fish to defend against vibriosis in seawater may be related to the degree of infection by other overt and/or latent freshwater pathogens. The smoltification process may be similarly affected by freshwater disease infection, thus compromising seawater survival. It must be emphasized that healthy fish must be released to maximize seawater survival and ultimate contribution.

The overall seawater survival of steelhead at Manchester was the lowest for all species tested despite the high (visual) percentage of smolts within most test groups. Initial high losses of fish (within 15

days following seawater entry) were attributed to direct osmoregulatory stress.

Water temperature has been associated with changes in both behavior and biochemical activity. When steelhead have been reared in fresh water above 12°C, impaired migratory behavior and reversion to parr (reduced gill Na^+-K^+ ATPase activity) have been observed (Zaugg et al. 1972; Zaugg and Wagner 1973). During seawater tests at Manchester, reversion to a nonsmolting condition (visual) occurred in all test groups. During the 1978 study, an increased incidence of external darkening and reduced number of smolts were observed in test groups when seawater temperatures exceeded 12°C. Therefore, seawater as well as freshwater temperatures above 12°C should be avoided to minimize interference with the smoltification process.

Health status, water temperature, and physiological status are factors affecting seawater adaptability. It is therefore difficult to recommend release criteria based on any one factor. Instead, close attention must be paid to husbandry and environmental conditions to optimize fish health and physiological status at the time of release.

The culturists must have at his disposal the ability to determine the physiological status of his fish. Only with this knowledge can the culturist determine the effect of various factors on smoltification of the fish under his care. The culturist is thus placed in a position to control the smoltification process and to determine time of release to maximize contribution and return.

Swimming Performance as an Indicator of Smoltification

Smoltification Indices

Swimming performance studies of coho salmon showed dramatic decreases in swimming efficiency (number of tail beats/minute required to maintain

position against a known water velocity) associated with the smoltification process (Figure 6). Experiments have shown that this decrease in efficiency is associated with the spring plasma thyroxine surge and, therefore, probably linked to metabolic changes. The decrease in swimming efficiency may render the fish unable to maintain its normal position in the stream and, thus, may be the impetus for downstream migratory behavior.

Our data show that this decrease in swimming efficiency is a repeatedly measurable phenomenon and, as such, a reliable indicator of smoltification. From a practical point of view, this may offer a simple, rapid means of determining smoltification, since swim chambers can be easily operated on-site by hatchery personnel. The swim chambers used in the present study had limited sample size capabilities (four to eight fish at a time). It is recommended that chambers with greater sample size capability be developed if hatchery testing is pursued.

Effects of Direct Seawater Entry

Our investigations indicate that coho salmon normally experience transient 30-75% depressions in swimming stamina at direct entry to seawater (Figure 7). The data suggest there may be a narrow "non-stressful" period at the optimum point of smoltification that allows coho salmon to enter seawater without suffering compromises in stamina. However, to date, no clear-cut relationship exists between the documented depressions in swimming stamina after direct seawater entry and smoltification status. Adaptability to seawater requires that salmonids make major osmotic adjustments. It is believed that the ionic imbalances which occur during adjustment to seawater cause inhibition of the

... swimming efficiency.

... 10-20% reduction in their ability to survive... directly influences its ability to survive this stress (Figure 5).

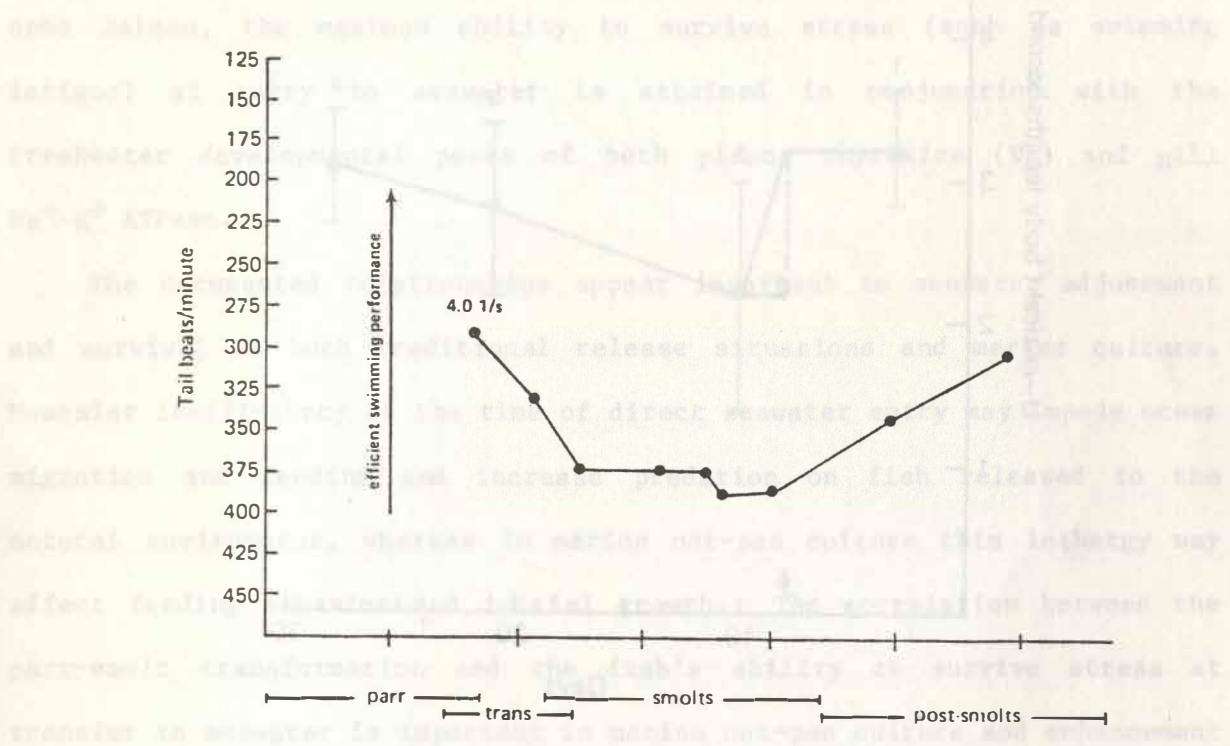

Figure 6.--Representative model of the decrease in swimming efficiency associated with the parr-smolt transformation of coho salmon. Figure is for the constant swimming velocity of 4.0 body lengths/second (1/s) which represents a water velocity of 1.0-1.5 mph. for smolt size fish.

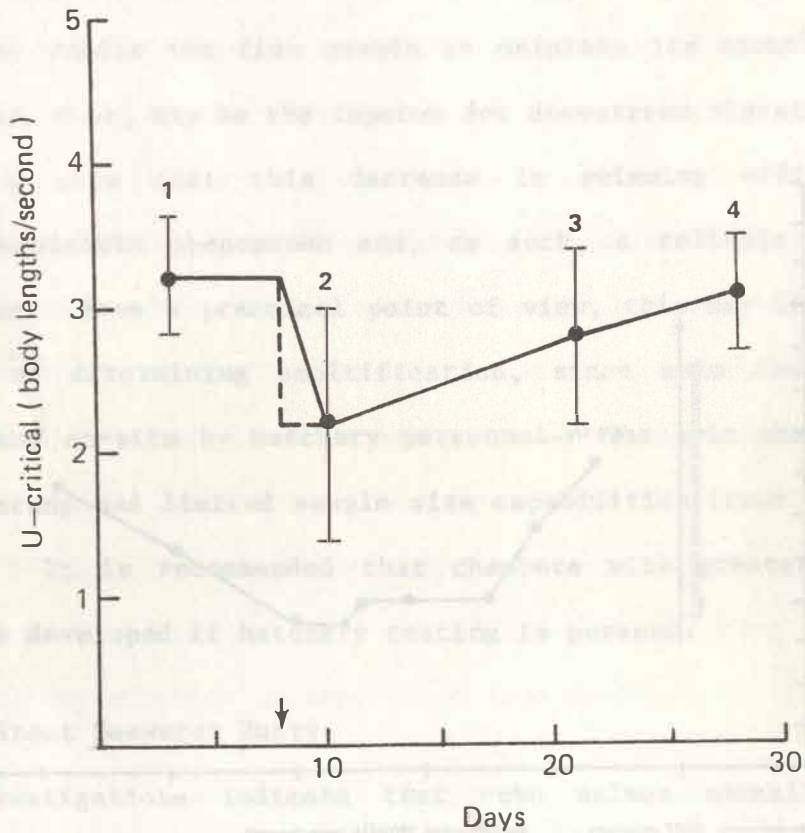

Figure 7.--Representative model of the depression in swimming stamina (U-critical) associated with direct seawater entry, and the recovery to the pre-entry (freshwater) level, for coho salmon. Figure shows: (1) fresh water, (2) first week of seawater, (3) end of second week of seawater, and (4) end of third week of seawater. Arrow indicates seawater entry. Dashes indicate probable decrease in U-critical coinciding with seawater entry. Brackets indicate \pm one standard deviation.

neuromuscular system which in turn causes the observed reductions in swimming stamina.

Our studies have also shown that coho salmon normally experience transient 10-50% reductions in their ability to survive swimming fatigue stress after direct entry to seawater. The fish's status of smoltification directly influences its ability to survive this stress (Figure 8). For coho salmon, the maximum ability to survive stress (such as swimming fatigue) at entry to seawater is attained in conjunction with the freshwater developmental peaks of both plasma thyroxine (T_4) and gill Na^+-K^+ ATPase.

The documented relationships appear important to seawater adjustment and survival in both traditional release situations and marine culture. Muscular inefficiency at the time of direct seawater entry may impede ocean migration and feeding and increase predation on fish released to the natural environment, whereas in marine net-pen culture this lethargy may affect feeding behavior and initial growth. The correlation between the parr-smolt transformation and the fish's ability to survive stress at transfer to seawater is important in marine net-pen culture and enhancement programs. In either situation, minimizing stress during and after seawater transfer is recommended. The evidence suggests that proper assessment of the status of smoltification is essential to attaining maximum seawater survival for coho salmon.

Fish Health, A General Evaluation

Fish health surveys were conducted on Columbia River fish stocks from 1978 through 1980. These surveys assessed fish health status of each test population at the time of release or transfer from the hatchery. We

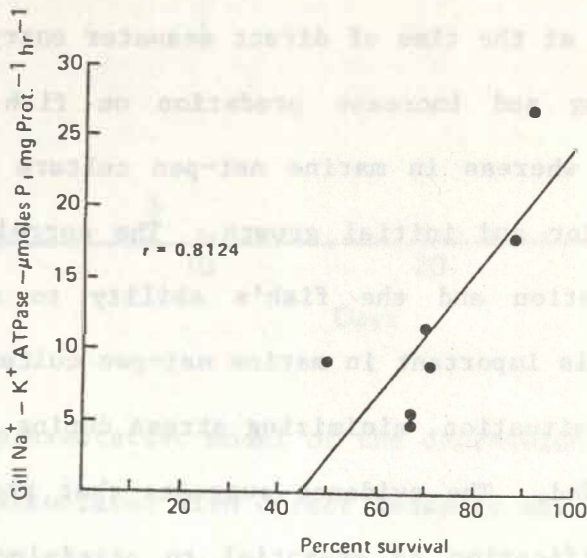
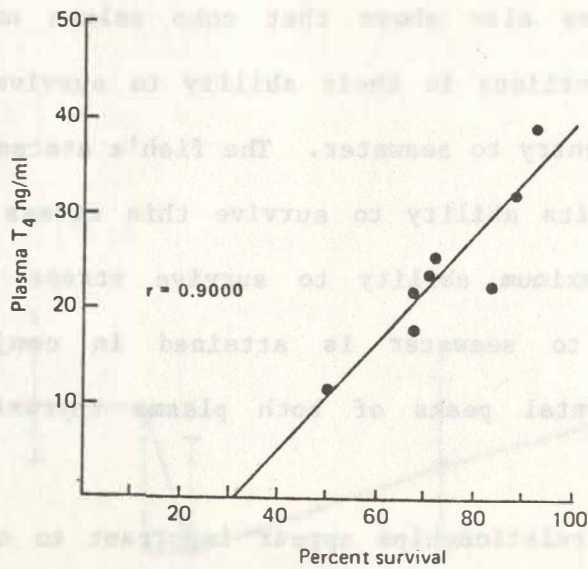

Figure 8.--Linear regression correlations between coho salmon's ability to survive swimming fatigue (to 7 days post-test) during their first week of seawater residence and their pre-entry (freshwater) levels of plasma thyroxine (T₄) and gill Na⁺-K⁺ ATPase.

attempted to determine whether a test group was compromised by poor health at the time of release, thus complicating the interpretation of the smoltification data. Information on infectious disease, hematology, and hatchery disease and treatment records were gathered on each test group.

We ascertained from hatchery records that most stocks of fish were treated for disease conditions at some time during freshwater rearing. The use of chemotherapeutics for disease control is a standard husbandry technique; however, this practice is known to affect smoltification and seawater survival. Bouck and Johnson (1979) demonstrated that the use of potassium permanganate as a therapeutic bath immediately prior to seawater entry could markedly reduce survival.

An example from our data shows the survival of Willard NFH fall chinook salmon was twice that of Bonneville Hatchery fall chinook salmon in seawater net-pens. The latter group was treated with potassium permanganate immediately prior to our seawater challenge. Based on the information available, we would recommend that the routine procedure at some hatcheries of treating all fish with chemotherapeutics just prior to release, even though no overt symptoms of disease are present, be discontinued.

There has been a long-standing belief among fisheries biologists that latent bacterial infections are exacerbated by the stress of seawater entry. The majority of the stocks we examined were subclinically infected with the causative agent of bacterial kidney disease (BKD) prior to seawater entry. There were, however, few incidences of BKD lesions visible to the unaided eye in post-mortem examinations of fish during 6 months of seawater culture. The development of a chronic condition like BKD may have

nothing to do with the marine environment but may be contingent upon many factors, e.g., genetic makeup. Our experience at Manchester suggests that seawater entry may have more of an affect on the acute freshwater diseases of salmonids, e.g., furunculosis and enteric redmouth disease. Survival and contribution to the fishery will certainly benefit from the release of a disease-free stock of smolted fish; however, the effects of infectious agents and parasites in the marine environment will probably remain unanswered in the near future.

Two viral diseases, infectious hematopoietic necrosis (IHN) and infectious pancreatic necrosis (IPN), have been reported in the Columbia River drainage (Parisot et al. 1965). During 1978, two independent laboratories examined samples of appropriate tissue from our test groups in an attempt to isolate these pathogens. The results were inconclusive in that one laboratory reported IHN in several test groups while the other laboratory reported no incidence of either virus. The implications of these findings remain unknown, but do help to point out the difficulties in viral diagnostics.

In an effort to use basic hematology as an aid in determining fish health, we found that only limited information on normal population values was available. The hematocrit and hemoglobin values obtained in these studies varied over a broad range for what we considered a normal healthy population of salmonids. Because of this variability, it was difficult to detect the presence of overt and latent diseases by this method. One exception was the third release group of fall chinook salmon from Willard NFH in 1978 which showed severe anemia. These fish were heavily infected with BKD at the time of their release.

The hematocrit and hemoglobin values obtained in these studies should contribute appreciably to the field of salmonid hematology. The use of these indices, however, as a single diagnostic tool to determine the presence or absence of disease or to solely document the general health of a fish population should be discouraged.

RECOMMENDATIONS

The following recommendations may help optimize smolt quality and control smolt metamorphosis so that timing of hatchery releases can coincide with or avoid environmental events in river, estuary, and ocean. Control of the smoltification process through environmental manipulation to fit specific resource management needs should lead to improved adult contribution.

1. We are of the opinion that a "quality control" monitoring system should be instituted in the public hatchery system. This monitoring system should use the best measures of smolt quality and should probably include gill $\text{Na}^+ - \text{K}^+$ ATPase, thyroid hormones, swimming performance, and size-frequency at the hatchery and perhaps some measure of seawater adaptation and migratory readiness. These measurements would determine optimum time for release and identify smoltification problems at hatcheries with a record of low contribution. Continuation of these measurements for the next decade, and the incorporation of new ones as they are developed, would provide historical perspective now lacking. Combined with large-scale tagging programs proposed for the 1980's, this information would be invaluable in assigning the relative importance of smolt quality, predation, density factors in the estuary, and ocean carrying capacity. Better understanding of the role of the hatchery environment on adult

contribution is essential before we embark on large-scale enhancement programs. Indeed, control of migration time and smolt quality may produce the same results in a more cost effective way than the massive enhancement programs now proposed for the 1980's.

2. Serial releases of yearling coho salmon from several hatcheries (size held constant) have shown that fish released at the peak of gill Na^+-K^+ ATPase- T_4 activity may not contribute as well as those released after the peak has been reached and begins to decline. It would appear that the development of full metamorphosis and hence maximum migratory readiness and seawater adaptability is not achieved until sometime in June for most stocks of coho salmon. It is not known when during the approximately 4-6 weeks of declining gill Na^+-K^+ ATPase- T_4 activity is the best time to release, but it is certainly later in the spring and more near the summer solstice than present release times.

Support for this hypothesis is also seen in the relationship between T_4 pulses and seawater adaptability. Survival of coho salmon in seawater is related to the area under the T_4 curve at release rather than the highest value attained. Therefore, thyroid hormone pulses in hatchery fish seem to be good predictors of subsequent seawater survival, showing that progression beyond the peak before release can enhance seawater adaptability.

3. Swimming performance has been shown to be a reliable indicator of smolting in coho salmon. From a practical point of view, this may offer the simplest, most rapid means of determining smoltification, since swim chambers could be easily operated on-site by hatchery personnel.

4. Water temperature has been shown to be an important controlling factor of the smolt metamorphosis of steelhead. Temperatures above 12.0°C in both fresh water and seawater appear to block the metamorphosis and reverse the process in some cases. We strongly recommend that steelhead not be reared in water above 12.0°C for several weeks prior to release and that they not be released into fresh water or seawater above this temperature.

5. A high percentage of precocious males was observed in most test groups of spring chinook salmon. Since precocious males do not contribute to the fishery, yet can make up a large portion of a population (we observed up to 15%), an effort should be made to identify the specific factors influencing this early maturation. Control of these factors could substantially increase the effective release from the hatcheries.

6. Blood ion measurements showed no consistent trends which could be used to evaluate smoltification status of Columbia River yearling coho salmon. Plasma calcium and potassium levels were shown to vary with stress. Based on our data, we cannot encourage the use of blood ions as a measure of smoltification in monitoring programs.

7. The use of hematocrit and hemoglobin values as a single diagnostic tool to determine the presence or absence of disease or to solely document the general health of a fish population should be discouraged.

8. The use of chemotherapeutics when no symptoms of disease are present should be discouraged.

9. Results from the delayed release of yearling coho salmon (June vs May) have been encouraging in terms of adult contribution. Such programs, however, have several undesirable aspects:

- a. Pond space is needed for new brood prior to June.
- b. Water is increasing in temperature and thus disease is a greater problem.
- c. Water flows in the Columbia River are usually less in June.
- d. Extended rearing costs more in feed and manpower.

We suggest that accelerated smoltification, through photoperiod control, be thoroughly evaluated. By advancing the photoperiod in the early spring months, yearling coho salmon would smolt 4 to 6 weeks earlier than normal. Under these conditions coho salmon could be released in May but in a state of smoltification resembling June. This procedure would eliminate the problems mentioned regarding delayed releases.

10. In developing release strategies, state and federal fishery agencies must take into account that each hatchery and the fish released from that hatchery are unique. The variability we have seen from one year to another at a single hatchery further helps to point this out. General release strategies can certainly be implemented, but the specific timing of the release from a hatchery should be based on biological data obtained on that specific group of fish. The extra time and money required to obtain such information would likely be more than compensated for through improved contribution.

ACKNOWLEDGMENTS

Our appreciation is expressed to the Oregon Department of Fish and Wildlife, Washington Departments of Fisheries and Game, and the U.S. Fish and Wildlife Service for their cooperation during these studies. The logistics of conducting extensive field-laboratory surveys of this type are enormous. The task could not have been accomplished without the cooperation of the above agencies and particularly the individual hatchery managers and their crews.

We are also grateful to Bernard J. Nist (Nature and Wildlife Photography) for his time and patience in photographing fish in various stages of smoltification.

REFERENCES

- Bouck, G. R. and D. A. Johnson.
1979. Medication inhibits tolerance to seawater in coho salmon smolts. *Trans. Am. Fish. Soc.* 108:63-66.
- Coastal Zone and Estuarine Studies Division, and Environmental and Technical Services Division.
1979. A study to assess status of smoltification and fitness for ocean survival of chinook, coho, and steelhead. Project 817. Coastal Zone and Estuarine Studies Division, Northwest and Alaska Fisheries Center, 403 p. (Processed).
- Dawley, Earl M., Carl W. Sims, Richard D. Ledgerwood, David B. Miller, and Frank P. Thrower.
1980. A study to define the migrational characteristics of chinook and coho salmon and steelhead in the Columbia River estuary. Coastal Zone and Estuarine Studies Division, Northwest and Alaska Fisheries Center, 53 p. (Processed).
- Merkel, J. C., D. L. Alverson, and J. Hough.
1978. Settlement plan for Washington state salmon and steelhead fisheries. Unpubl. rep., 347 p.
- Parisot, T. J., W. T. Yasutake, and G. W. Klontz.
1965. Virus diseases of Salmonidae in Western United States. I. Etiology and epizootiology. *Ann. NY Acad. Sci.* 126(1):502-519.
- Prentice, E. F., C. Mahnken, K. Gores, W. Waknitz, L. Folmar, R. King, J. Mighell, W. Dickhoff, T. Flagg, L. Harrell, A. Novotny, D. Damkaer, E. Wold, and R. Vreeland.
1980. A study to assess status of smoltification and fitness for ocean survival of chinook and coho salmon and steelhead. FY 1979-80, Project 10990060. Coastal Zone and Estuarine Studies Division, Northwest and Alaska Fisheries Center, 408 p. (Processed).
- Wahle, Roy J., and Robert J. Smith.
1979. A historical and descriptive account of Pacific Coast anadromous salmonid rearing facilities and a summary of their releases by Region, 1960-76. NOAA Technical Report NMFS SSRF 736:1-40.
- Zaugg, W. S., B. L. Adams, and L. R. McLain.
1972. Steelhead migration: potential temperature effects as indicated by gill adenosine triphosphatase activities. *Science* 176:415-416.
- Zaugg, W. S. and H. H. Wagner.
1973. Gill ATPase activity related to parr-smolt transformation and migration in steelhead trout (*Salmo gairdneri*): influence of photoperiod and temperature. *Comp. Biochem. Physiol.* 45B:955-965.