

NCU-T-78-007 C. 2

CIRCULATING COPY
Sea Grant Depository

People
Property
Coast of North Carolina

LOAN COPY ONLY

This work was sponsored by the Office of Sea Grant, NOAA, United States Department of Commerce, under grant number 04-8-M01-66 and the North Carolina Department of Administration. The U.S. Government is authorized to produce and distribute reprints for governmental purposes notwithstanding any copyright that may appear hereon.

Storms, People and Property In Coastal North Carolina

by

**Simon Baker
UNC Sea Grant College Program
and
Geography Department
East Carolina University**

Edited by

**Karen Jurgensen
UNC Sea Grant College Program**

Cover: Hurricane Belle off the eastern United States, August 9, 1976.

Copies of this publication are available from:

UNC Sea Grant
105 1911 Building
North Carolina State University
Raleigh, North Carolina 27650

Foreword

Waves which once broke on uninhabited North Carolina shores now break in the front yards of cottages, motels and apartment buildings. The use of land on the barrier islands has changed since old-timers shunned the beach for wooded, sheltered spots. But the pattern of the legendary storms which strike the coast remains the same.

Inevitably, the storms of the future will endanger more lives and property than they do now. People will continue to live on the barrier islands or visit them because of the beauty and recreational opportunities found there. Does this mean that we are creating an impossible situation where death and destruction will be the price we pay for the use of the islands? This need not be so if we understand the nature of the barrier island environment and act upon that understanding.

For one thing, it must be recognized that hurricanes are a regular feature along the North Carolina coast. The recent quiet years after the intense storm activity of the 1950s have created a false sense of security about hurricanes. We must choose the safest possible building sites, keeping in mind the history of hurricanes on this part of the Atlantic coast. Another important thing to be remembered is that the coast regularly experiences extratropical storms. These storms do not approach the violence and high winds of hurricanes, but they often create considerable damage because of their longevity.

In locating permanent structures the dynamic nature of the barrier islands must be taken into account. These are sand islands which are shaped by winds, currents and a rising sea level, as well as the annual cycle of storms. Erosion on the islands is not new, it is and has been an everyday occurrence since the islands came into being. Buildings and roads must be well back from the beaches and especially from those most changeable features of all, the inlets. The structures themselves can be made quite wind-resistant and can be elevated to avoid damage from most flooding. With sensible precautions it should be possible for people to live on the barrier islands at a reduced level of risk. Given the nature

of the coastal environment, however, it is not possible to discount all risk.

The purpose of this publication is to inform the reader of the nature and frequency of storms on North Carolina's coast and the dangers associated with them. The preservation of life and the safety of coastal dwellers are of the utmost importance. Whenever instructions are issued by Civil Preparedness or other governmental authorities to evacuate, they should be complied with immediately. Should the reader find himself in a position where he is unable to leave his residence after a hurricane warning has been issued, there are a number of actions he can follow to insure his safety. This publication offers practical tips which people living directly on the coast and in low-lying areas further inland can follow before, during and after storms to protect life and property.

Contents

Foreword	i
Storms of Tropical Origin	1
Hurricanes: The Damaging Forces	12
Northeasters: Storms of Extratropical Origin	27
Surviving It--Safely	33
What's Safe to Eat and Drink	39
Keeping a Roof Over Your Head	45
Boating It	51
On the Farm	53
Appendices	
Civil Preparedness Information	61
Disaster Fact Sheets	64
Definitions of Terms Associated with Hurricanes	65
Wind Effects Over Water	68
Coastal Hurricanes of the Twentieth Century ...	70
Some Severe Twentieth Century Extratropical Storms	74
Atlantic Hurricane Names	78
References	79
Illustration Credits	82
Acknowledgments	83

Storms of Tropical Origin

Tropical cyclones--including hurricanes--like many other natural phenomena, do not occur on a regular basis. There may be periods of great storm activity followed by quiet years. This has been the recent hurricane history of the North Carolina coast. The middle 1950s was a period of intense activity with three hurricanes making landfall in 1955 alone (Figure 1). The period since then has been relatively quiet, and there are many coastal inhabitants and summer residents who have never experienced a hurricane.

On the Gulf of Mexico and Atlantic coasts, hurricane season lasts roughly from June through November. August, September and October are the months of maximum storm activity on the average. Of course, variations occur from place to place.

By the time hurricanes reach the North Carolina coast they have travelled great distances. Their origins have been traced to the Gulf of Mexico, the Caribbean Sea, the Atlantic to the east of southern Florida, or farther out in the Atlantic to the east of the Lesser Antilles. Some storms may originate as far away as the Cape Verde Islands off the west coast of Africa or even the Sahara Desert.

A hurricane and its lesser cousin the "tropical storm" are tropical cyclones. When a tropical cyclone has wind speeds of 39 to 73 miles per hour (34 to 63 knots) and the circulation is in rotary fashion it is classified as a "tropical storm." When the rotary circulation of winds is very pronounced and wind speed exceeds 74 miles per hour (64 knots) the tropical cyclone is described as a "hurricane."

The word "cyclone" is sometimes confusing because in parts of the United States (US) it is synonymous with tornado. It does not have that meaning in this publication but is used in the general meteorological sense (see Appendix III for a definition).

Hurricanes are round or spiral shaped and, on the average, are about 100 miles in diameter. Within this area the winds exceed 74 miles per hour while outside of it, up to a diameter of 400 miles, the winds may be above 40 miles per hour, or gale-force. The whole cyclonic storm moves across the tropical ocean with a forward speed of about 12 to 14 miles an hour.

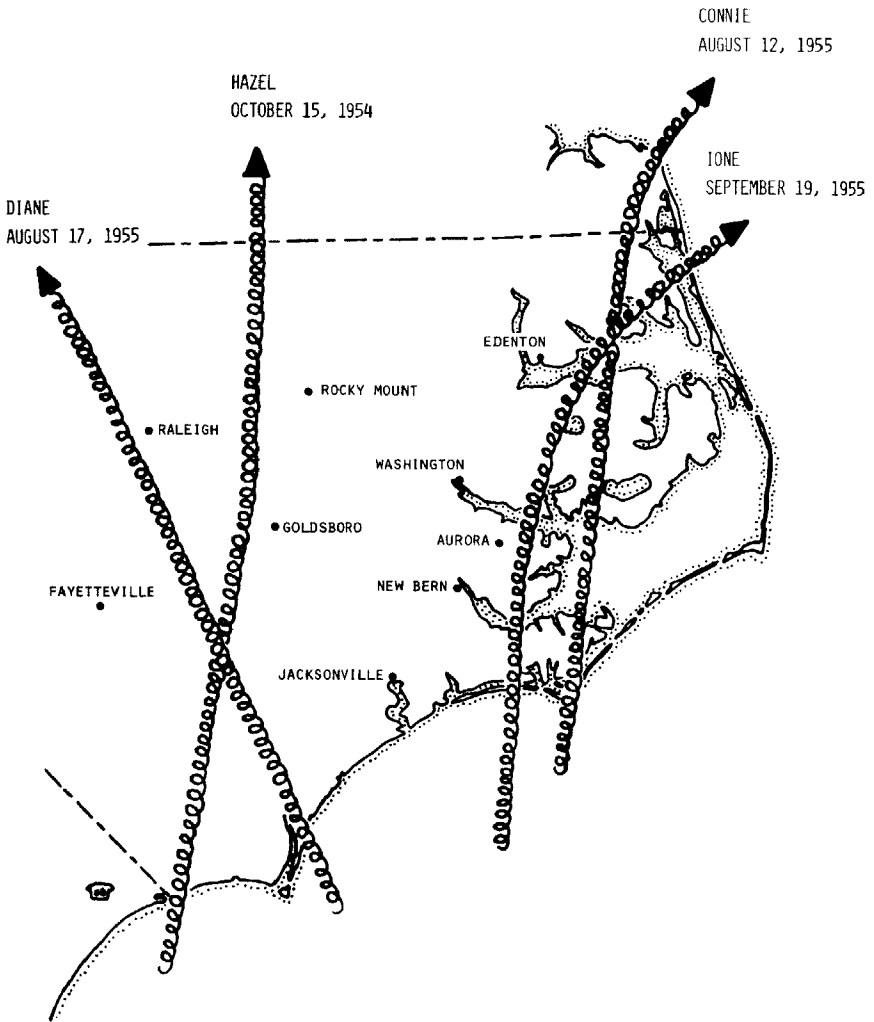

Figure 1. In less than 12 months, between October, 1954, and September, 1955, four hurricanes made landfall on the North Carolina coast and passed through the state. Shown here are the paths these storms followed. On the average, hurricane force winds are felt 50 miles on each side of the storm path and gale force winds up to 200 miles on each side. During this period of intense storm activity, practically all parts of eastern North Carolina experienced hurricane force winds.

The mature hurricane has at its core an eye or relatively calm and sometimes cloud-free center averaging 14 miles in diameter. Inwardly spiralling winds form a thick wall of cloud as they are whirled upward around the eye. Winds are at their strongest here and may reach speeds of over 100 miles per hour. Other thick walls of cloud form great spirals as they converge on the center of the hurricane. (See photograph on the front cover.) It is from these clouds that the heavy precipitation falls, and any given place in the path of a hurricane may experience a total of from 6 to 12 inches of rainfall with occasional amounts exceeding 30 inches.

The amount of energy in a hurricane is difficult to comprehend, but an estimate appearing in Hurricane, the Greatest Storm on Earth* suggests that the heat energy released in one day "is the equivalent of that released by fusion of 400 20-megaton hydrogen bombs. Put in more comprehensible terms, one day's released /wind/ energy, converted to electricity, would supply the United States' electrical needs for more than six months."

These powerful storms have been striking the islands of the Caribbean and Gulf and Atlantic coasts of North America as far back as we have written records. There is ample evidence in the lore of the pre-Columbian inhabitants of these coasts that hurricanes were a regular feature of their lives. Historical studies have been conducted on the paths hurricanes follow before reaching various parts of the US coastline. One such study for the years 1886-1963 is illustrated by Figure 2. From this map we can see that the incidence of hurricanes varies from place to place along the coast. Some sections of the coastline have had few hurricanes make landfall while others, such as the Gulf, have had more than their share. It is clear also that North Carolina has been the recipient of many such storms.

Even on the North Carolina coast, storm activity varies. For example, one study indicates that the area between Cape Hatteras and a point southwest of Jacksonville experiences a longer storm season than the rest of the state's coast. And within that area, the section between Capes Lookout and Hatteras experiences more tropical cyclones than any other section of the coast. This information comes from Atlantic Hurricane

* References are listed on pages 79-81.

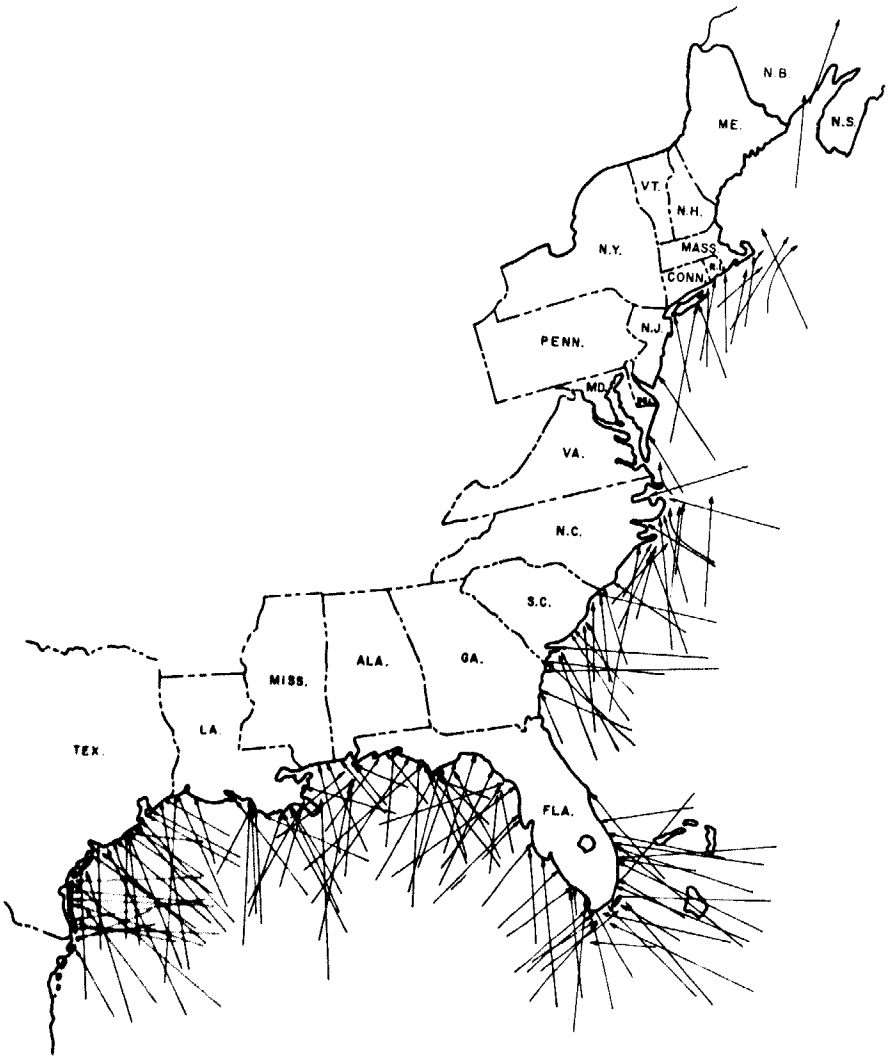

M 128 676

Figure 2. Hurricanes crossing the Gulf of Mexico and Atlantic coasts, or passing near the mainland, 1886-1963.

Frequencies Along the US Coastline, which is a detailed study of 50-mile segments of the US Gulf of Mexico and Atlantic coastlines for the 85-year period of 1886 to 1970. The study provides a more detailed look at North Carolina's coast. The coast was divided into 50-mile lengths because it was felt that this size is the smallest segment for which a meaningful summary could be made for the purpose of examining hurricane events. The segments covering the North Carolina coast are labeled A through F in this publication. The locations of the segments or sectors can be seen in Figure 3 and the following maps. Segment A lies partially in South Carolina and segment F is partially in Virginia. The remaining segments B, C, D and E are entirely within North Carolina and each one is approximately 50 miles in length.

Only storms entering the coastal area from the sea were tabulated in the National Oceanic and Atmospheric Administration study. Those storms which passed offshore and did not touch land were not counted. Also, it was assumed that hurricanes crossing the shoreline in one segment affected the adjacent segments which lay in the right semicircle of the storm where high winds are normally experienced. This means that a storm coming ashore in segment C was not only counted there but also in segment D to its right. This method of counting is only true for tropical cyclones of hurricane intensity and higher. It is not true for tropical cyclones of less than hurricane intensity, that is, with winds of less than 74 miles per hour.

It should be noted that the information shown in Figures 3, 4, 5 and 6 is representative only of the 85 years of records which were studied. They help us to understand what has transpired on our coast so that we may have some indication of differences from place to place and also have some indication of what to expect in the future.

Length of the season of tropical cyclones varies considerably along this coast. Figure 3 indicates the earliest and latest occurrences of tropical cyclones during the study period, and this is an indication of length of season. Using these criteria, sectors C and D--Cape Hatteras to approximately the vicinity of Jacksonville--must be considered to experience the longest seasons while sectors E and F to the north of Cape Hatteras only experience brief periods during which they are subjected to tropical cyclones.

Figure 3. Earliest and latest occurrences of tropical cyclones with maximum sustained winds of 40 miles per hour or higher. Dates indicate landfalls made by storms in each sector for the period 1886-1970.

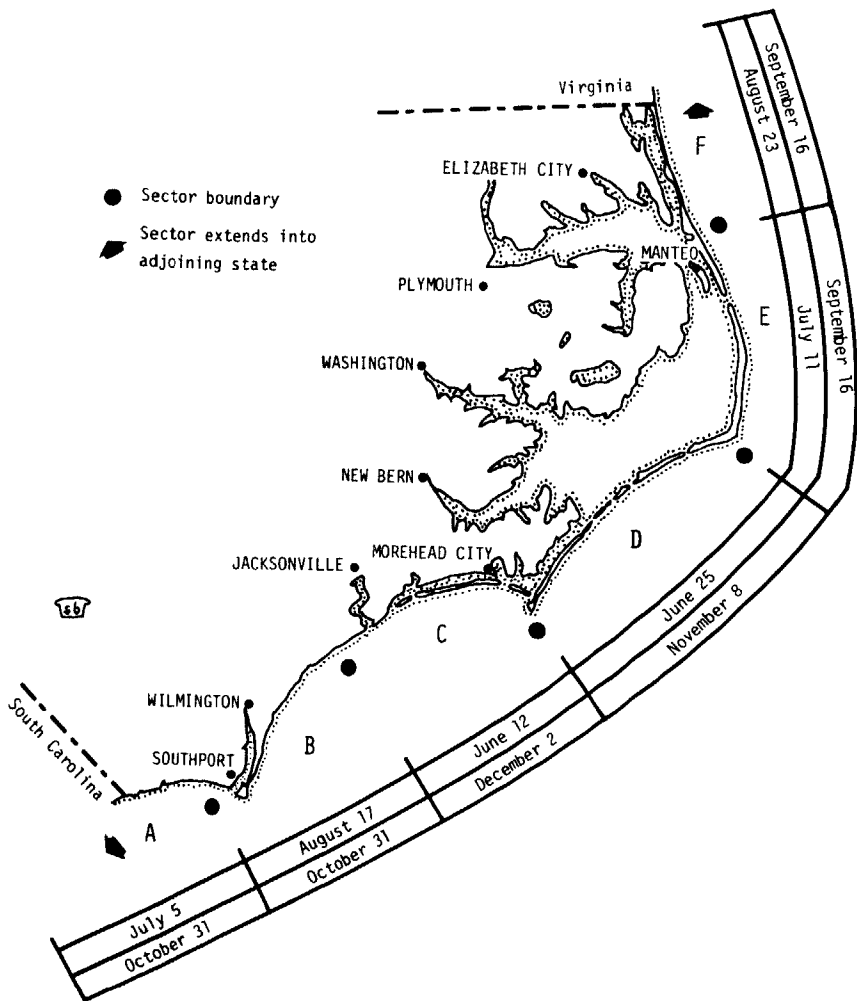

Figure 4. Number of tropical cyclones reaching the North Carolina coast 1886-1970 by sectors.

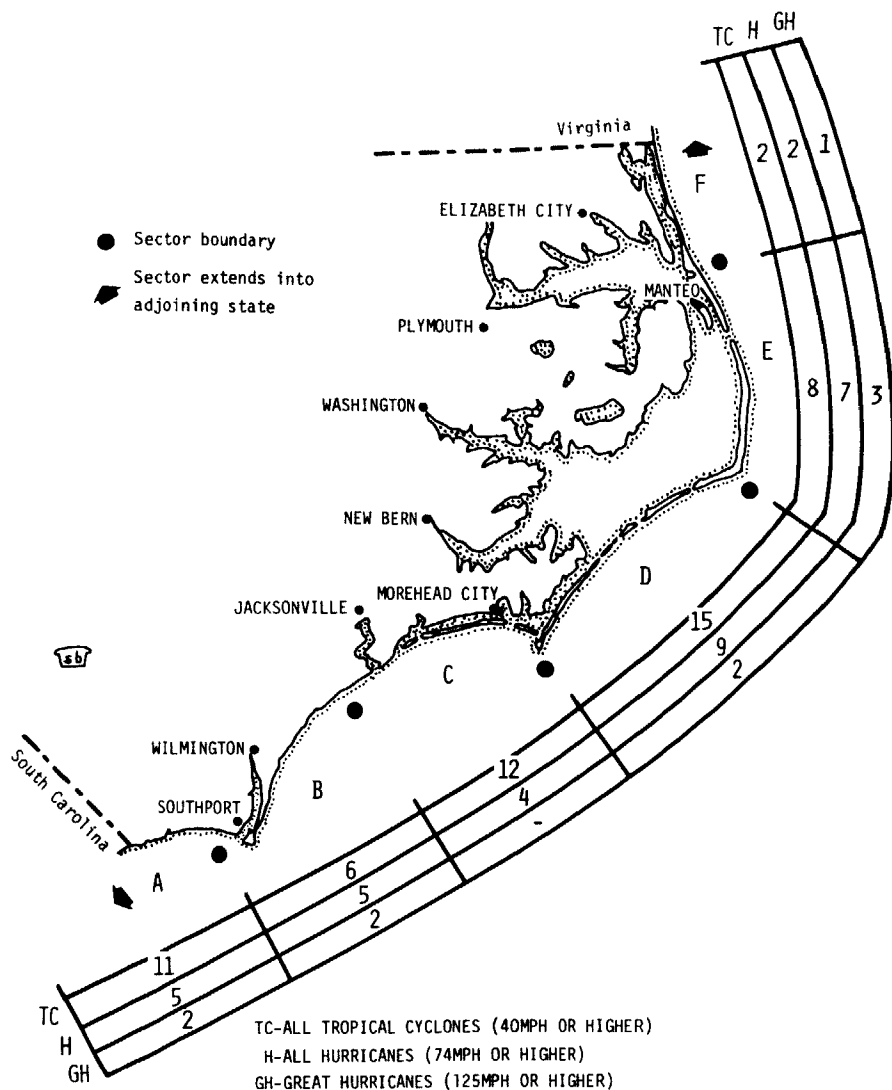

Figure 5. Number of years between tropical cyclone occurrences. Average for the period 1886-1970 by sectors.

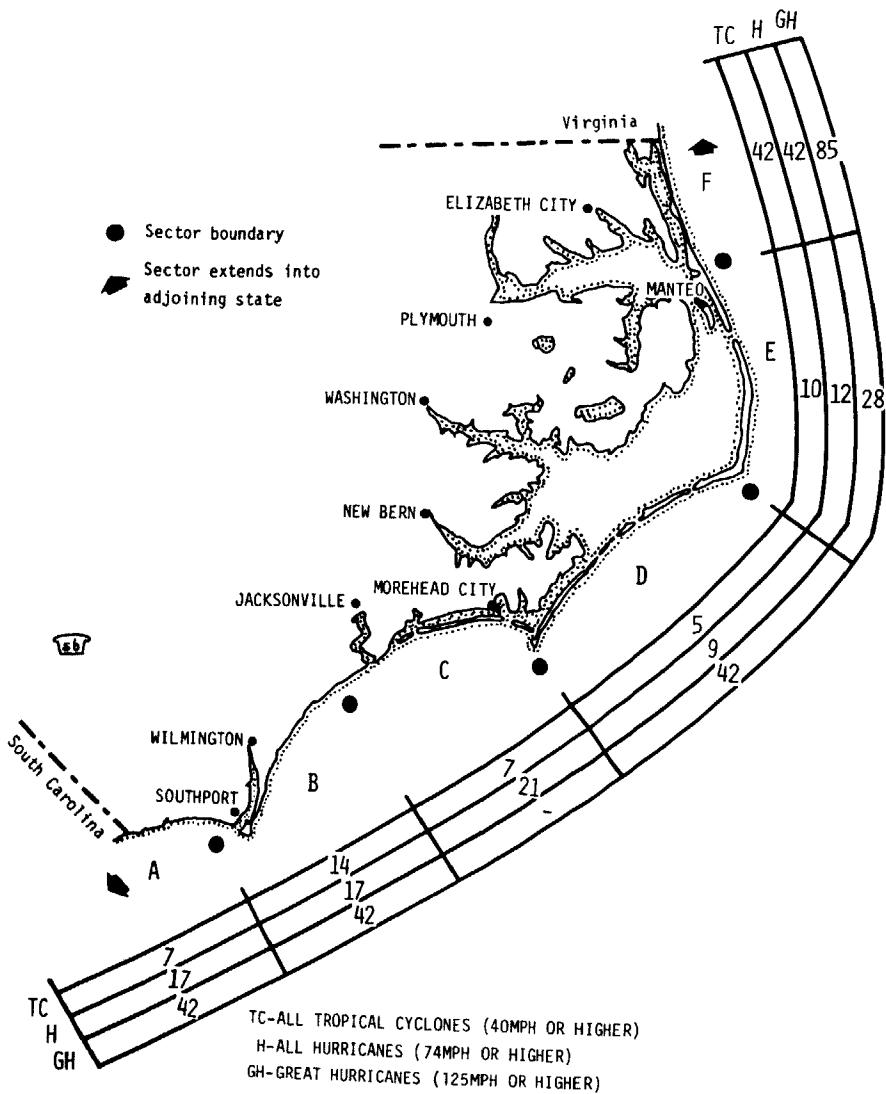
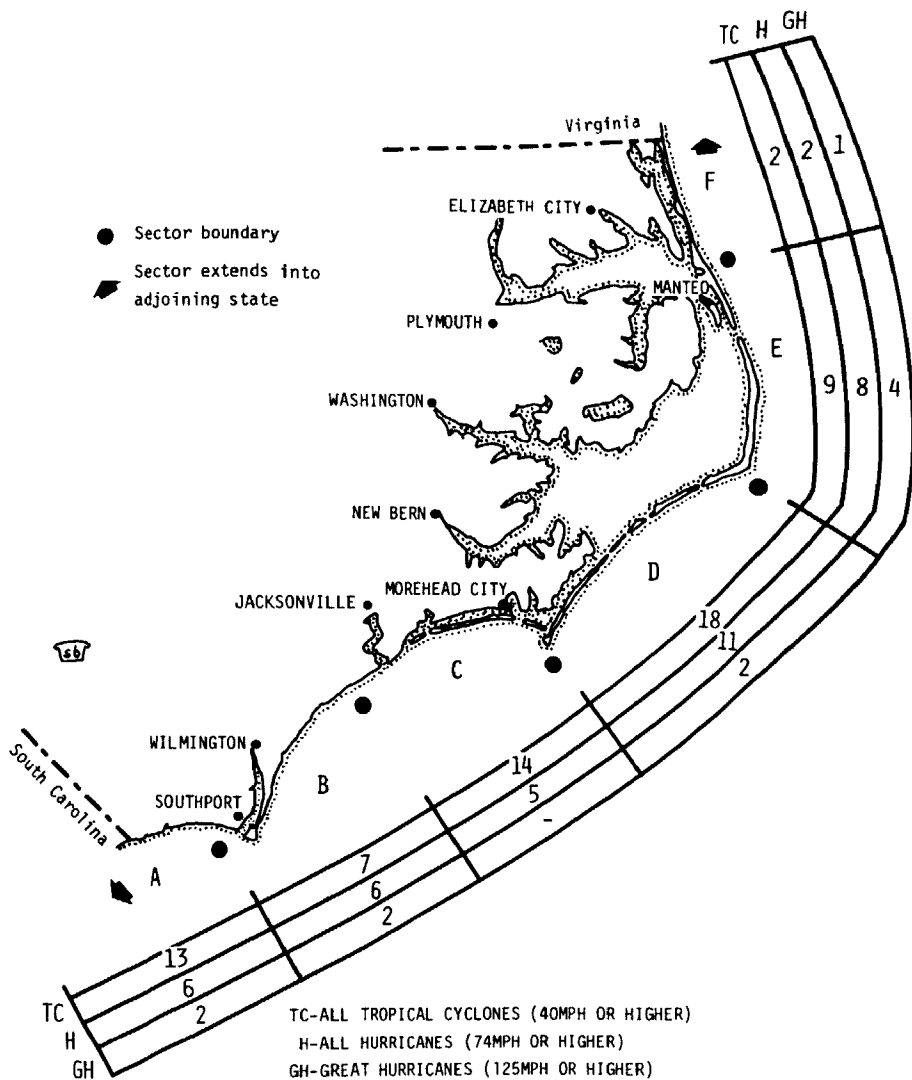

Figure 6. The probability (percentage) that a tropical cyclone, hurricane, or great hurricane will occur in any one year in a sector of the coastline.



Sectors A and B in the south appear to have seasons of intermediate lengths.

The number of tropical cyclones of varying intensity which has reached this coast is depicted in Figure 4. In sector D--Cape Hatteras to Cape Lookout--which has experienced the highest number of tropical cyclones during the 85-year period, nine of those cyclones were of hurricane intensity. Of the nine hurricanes two were powerful enough, with winds of 125 miles per hour or higher, to be classified as great hurricanes. The study recognizes this latter type of storm because "due to both storm surge inundation and wind stresses on structures, storms in this category can be expected to bring major disasters to metropolitan areas with heavy damage to structures and high potential for loss of life." All of the sectors but C (Cape Lookout to a point southwest of Jacksonville) have experienced at least one great hurricane during the 85-year study period. This does not mean that sector C is immune from these violent hurricanes, only that none were recorded during the study period.

Another way of looking at the record is from the point of view of time between occurrences of tropical cyclones. In Figure 5, average times between the three types of storms occurring over the 85-year study period have been calculated and are shown for each sector. Thus, in sector C there is a blank for great hurricanes because none occurred during that time while in sector F the figure shown for such storms is 85 years since only one occurred during the study period. In sectors A, B, and D the time is given as 42 years because two large storms occurred in each one in a period of 85 years. Sector E shows 28 years between great hurricanes to account for the three experienced.

Of more interest to coastal dwellers perhaps is the number of years between occurrences of tropical cyclones of all types. By far the most storm-ridden sector is D, lying between Cape Lookout and Cape Hatteras. On an average of every five years this portion of our coast experienced some sort of tropical cyclone. Sectors A and C experienced tropical cyclones on an average of every seven years. At the other end of the scale, the quietest part of our coast is sector F which experienced only two tropical cyclones of any type during the 85 years of the study, hence the average time of 42 years between occurrences.

As shown in Figure 6, Sectors A, C and D are those with the greatest probability of experiencing tropical cyclones. Sectors D and E have the greatest probability of experiencing hurricanes and sector E the greatest probability of experiencing great hurricanes. An 18 percent probability indicates 18 chances in a 100-year period or one storm every five to six years. This estimate of the mathematical probabilities is based on the assumption that "the statistical properties of the data sample represent the properties of the entire population of events (i.e., all coastline crossings)."

Hurricanes: The Damaging Forces

High winds are generally what people think of when they think about hurricanes. Those who have experienced these storms have vivid memories of the winds. Those who have read about hurricanes or seen them on film come away with a strong impression of the wind and its power. Many people assume that it is the force of the wind directly against trees and buildings that is the main cause of destruction by hurricanes.

In fact, along our coasts there are three consequences of the passage of hurricanes which cause destruction and death. Of these three, damage caused by the direct action of wind is the least severe. The most destructive force generated by a hurricane is usually the storm surge. Next in destructive power is flooding caused by the torrential rains normally associated with hurricanes. The power of moving water can be far more destructive than that of moving air.

Storm Surge

There appears to be some confusion over storm surges. The surge is sometimes less correctly called a "storm tide," or a "hurricane tide," or even a "tidal wave" when the surge is being forced up a river channel. The important thing to understand is how storm surge comes into being: the storm surge is a mound of water pushed up by winds ahead of a hurricane advancing landward from a large body of water. In the open ocean the surge may be hardly noticeable, but when it approaches a shallow shore the effect is dramatic. The mound of water may be 50 or more miles wide as it crosses the coastline. Depending on the conformation of the shore and bottom, the storm surge may reach heights of 15 feet or more above the normal (astronomical) tide level. Added to this are the large wind-driven waves which usually top it off. The greatest storm surge is most often experienced on the right-hand side and close to the eye of the hurricane as one faces in the direction of the forward motion of the storm. Figures 7, 8 and 9 illustrate the relationship between normal sea level, astronomical tide, and the build-up of water as storm surge strikes a shore.

Storm Surge: The Most Deadly Killer

The three sets of drawings on these pages show the formation and effects of the hurricane storm surge. Many factors are involved in the formation and propagation of a storm surge such as the strength of the storm, bottom conditions where the surge comes ashore, and the position of the storm center in relation to the shore. These diagrams, therefore, cannot be representative of all surges for all coastal areas. The surge diagramed here is typical of those produced by a hurricane approaching the lower-Atlantic or Gulf coastal areas.

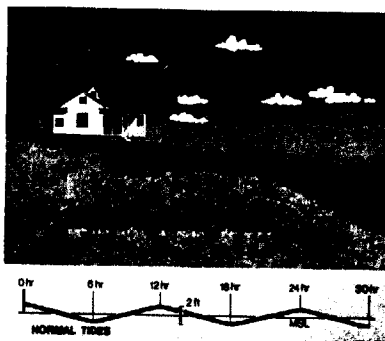

Figure 7. It is a normal day. The sea rises and falls predictably with astronomical tidal action. There are the usual small waves. A hurricane has developed and a Hurricane Watch is in effect for the area.

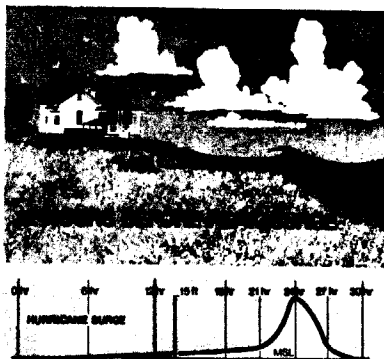

Figure 8. The hurricane now poses a serious threat to this beach area and the Watch has been changed to a Hurricane Warning. The hurricane is 12 hours away. The tide is a little above normal; the water moves further up the beach. Swells are beginning to move in from the deep ocean and breaking waves--some as high as five to eight feet--crash ashore and run well up the beach. The wind is picking up.

*Mean sea level

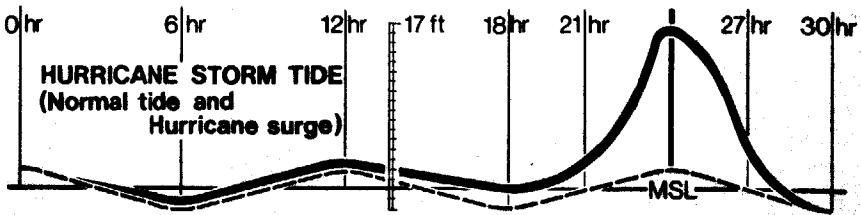
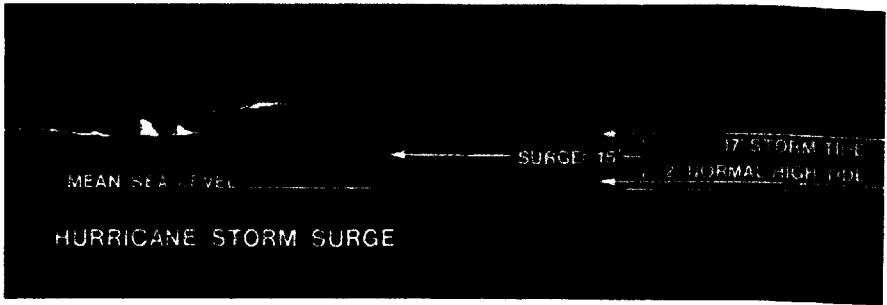

Figure 9. The hurricane is moving ashore close to the beach area. It is time for high tide again. This time, however, there is a 15-foot surge added to the normal 2-foot astronomical tide creating a 17-foot storm tide. This great mound of water, topped by battering waves, is moving slowly ashore along an area of coastline 50 to 100 miles wide. Winds are now over 130 miles an hour. Much oceanfront property will be unable to withstand this combined assault of wind and water.

The combination of storm surge, battering waves, and high tide is the hurricane's most deadly killer.

In coastal locations the combined flooding and pounding by waves of the storm surge are the great destroyers of life and property. The most recent spectacular example of a high surge in the US was Hurricane Camille which struck the Mississippi coast in 1969. Winds of up to 175 knots created a storm surge of 24.2 feet which swept ashore and was responsible for more than \$1 billion in damage in Louisiana and Mississippi alone. The loss in lives along the Gulf coast was 146 with 27 missing. Most of the dead were drowned. In the US there have been other disasters in which great loss of life was attributed to storm surge:

- Hurricane Audrey, June, 1957, Louisiana, 380 dead
- New England Hurricane, September, 1938, 600 dead
- Florida hurricane, September, 1935, 400 dead
- Galveston hurricane, September, 1900, 6,000 dead

The lightly populated North Carolina coast has never experienced or equaled the death and destruction of these storms. The closest the state has come to anything like this was on October 15, 1954, when Hurricane Hazel made landfall on the South Carolina line in the vicinity of Calabash (Figure 1). The combination of the storm surge and the wind-driven waves riding on top of it resulted in severe damage to structures and the coastline itself. For 20 miles east of where the eye made landfall the storm surge was nine to 12½ feet above normal. Between 20 and 40 miles to the east the storm surge was from five to nine feet above the normal tidal level. From 40 to 80 miles to the east the surge was from four to seven feet higher than the usual tide level (Figures 10 and 11). The official report of the Raleigh National Weather Bureau Office described the storm as follows:

Wind-driven tides devastated the immediate ocean front from the South Carolina line to Cape Lookout. All traces of civilization on that portion of the immediate waterfront between the state line and Cape Fear were practically annihilated. Grass-covered dunes some 10 to 20 feet high along and behind which beach houses had been built in a continuous line five miles long simply disappeared, dunes, houses and all. The paved roadway along which the houses were built was partially washed away, partially buried beneath several feet of

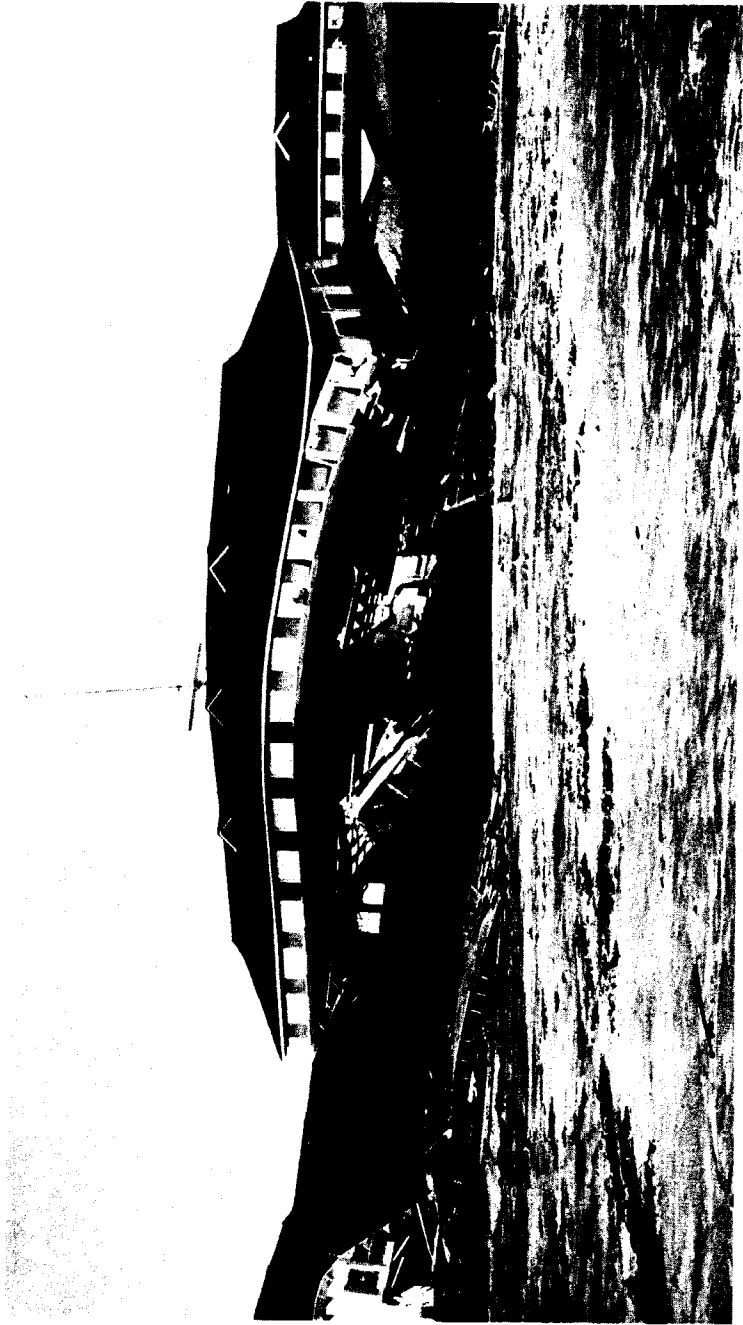

Figure 10. Storm surge generated by Hurricane Hazel on October 15, 1954, wrecked the Carolina Yacht Club on Wrightsville Beach.

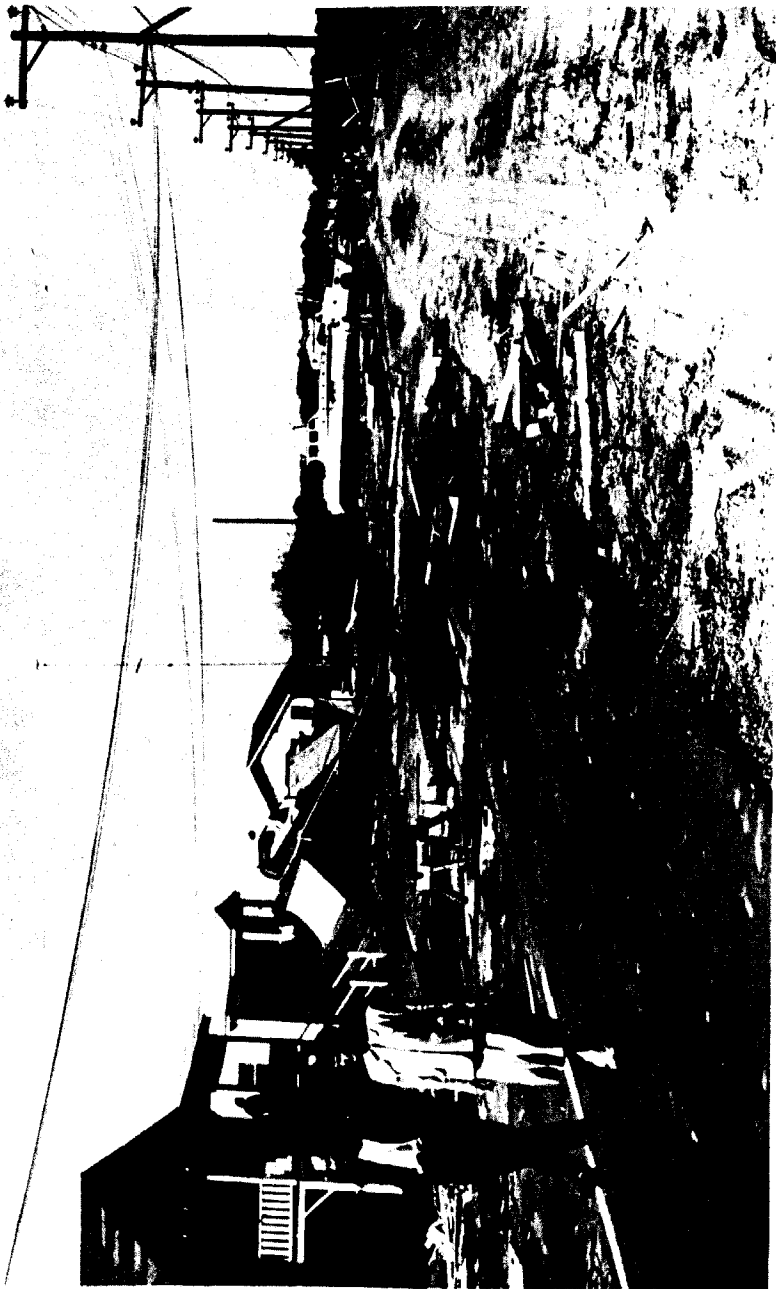

Figure 11. Large boats carried ashore near Wrightsville Beach by Hurricane Hazel's storm surge on October 15, 1954.

sand. The greater part of the material from which the houses had been built was washed from one to two hundred yards back into the edge of the low-lying woods which cover the leeward side of the islands. Some of this material is identifiable as having been parts of houses, but the greater portion of it is ground to unrecognizable splinters and bits of masonry. Of the 357 buildings which existed on Long Beach, 352 were totally destroyed and the other five damaged. Similar conditions prevail on Holden Beach, Ocean Isle, Robinson Beach and Colonial Beach. In most cases it is impossible to tell where the buildings stood. Where grassy dunes stood, there is now only flat, white, sandy beach.

In addition to the spectacular property damage and dune destruction, 19 people were known to have died in North Carolina. Most of the victims lost their lives at or near the beach, and the storm surge is believed to have been largely responsible. Another 200 people in various locations suffered injuries during Hurricane Hazel.

Not only the beaches but also low-lying coastal areas are affected by storm surge. Those low-lying mainland areas bordering the sounds are important for forestry and farming. During the hurricanes of 1954 and 1955, storm surge was responsible for moving salt water from the sounds and bays onto agricultural and forest lands. Most of the land less than 10 feet above sea level suffered from the intrusion of salt water or from flooding caused by the heavy rains. This combined flooding was responsible for extensive losses of corn, soybean, peanut, cotton and tobacco crops (Figure 12). About 25 percent of the area of the 22 coastal counties was estimated to have been covered by fresh and salt water during the 1954 and 1955 hurricanes.

Flood

After storm surge, the flooding caused by heavy hurricane rains is the next most important danger to human life. Even on a low-lying coast such as North Carolina's the flooding caused by hurricane rains has

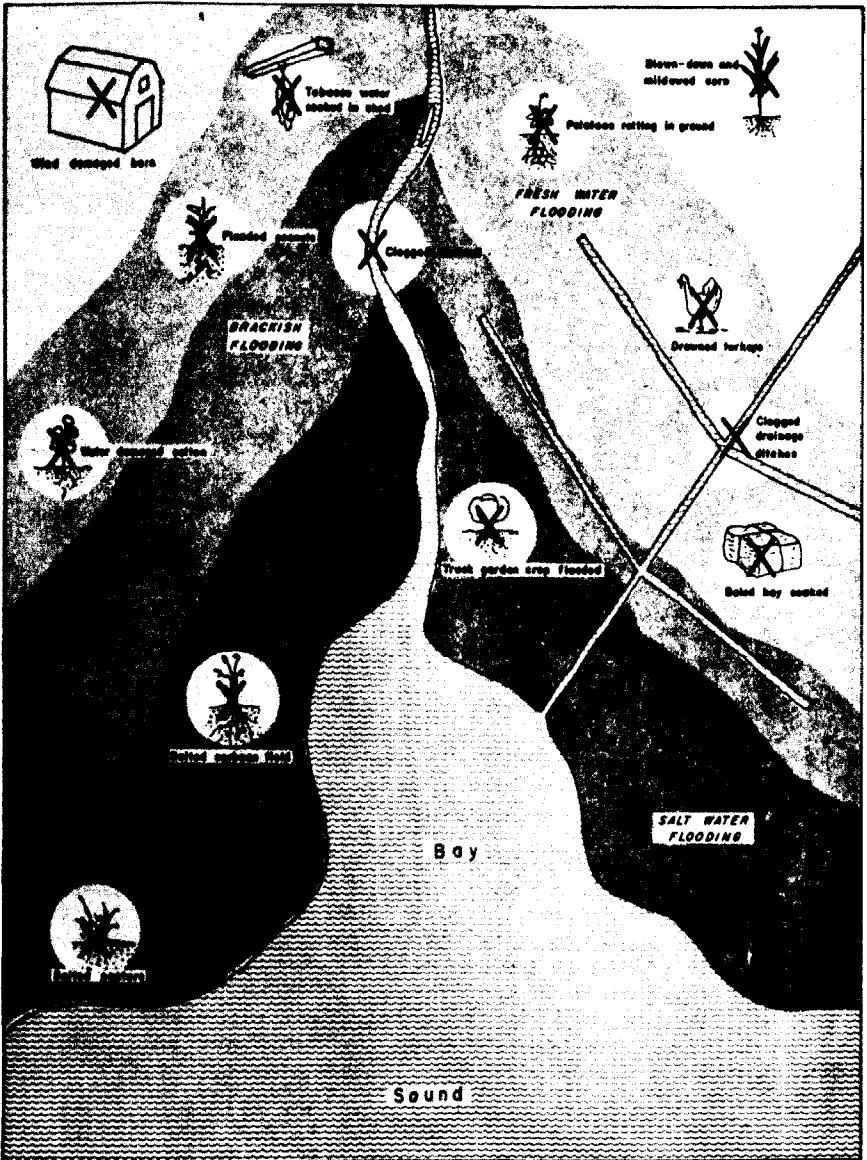

Figure 12. Flooding caused by heavy rainfall and hurricane storm surge driven onto the mainland frequently are major sources of damage to coastal agriculture. Wind damage also can be destructive to buildings and crops.

a considerable impact on cities, agriculture and transportation. It is in hilly or mountainous areas that such heavy rains are not only destructive of property, but are also a danger to people. The entire state of North Carolina is vulnerable and has, at one time or another, felt the effects of hurricane rains.

In fact, the interiors of the southeastern, middle Atlantic and northeastern states are all vulnerable to heavy hurricane rainfall which is a great destroyer of property and life. Hurricane Agnes, which struck in 1972, dramatically emphasizes the fact that it is not coastal locations alone which stand to suffer from the effects of hurricanes.

Agnes is the most destructive and costly tropical cyclone ever to hit the US (Figure 13). Only a small fraction of the damage was caused by storm surge and winds. Heavy rains followed the passage of this storm as it moved from the Florida Panhandle northeastward across Georgia, South Carolina, North Carolina and out to sea. It then turned back and passed over New Jersey and Pennsylvania before dissipating. After making its initial landfall on the Florida coast it lost its hurricane strength winds and did not regain these velocities during the entire passage of the storm over land.

All along the path of Hurricane Agnes, flooding occurred on small tributaries and major streams. Buildings were swept away or inundated. Crops were destroyed. Bridges and small dams were threatened. Towns and cities were paralyzed as a result of the flood waters. Agnes was responsible for a record \$3.09 billion in damage to property and a loss of 117 lives. More than \$2.8 billion in damage and 72 deaths occurred in Pennsylvania and New York alone. What is memorable about Hurricane Agnes is that more than \$3 billion of the total damage and almost all of the deaths were caused by the torrential rains that fell during the storm.

Wind

The least destructive feature of a hurricane, but perhaps the most awesome one, is its winds. Air circulates inward toward the eye in a counterclockwise direction in the Northern Hemisphere. The winds

U.S. CLOUD COVER
21 JUNE 1972
TIME OF PHOTO 1800 GMT

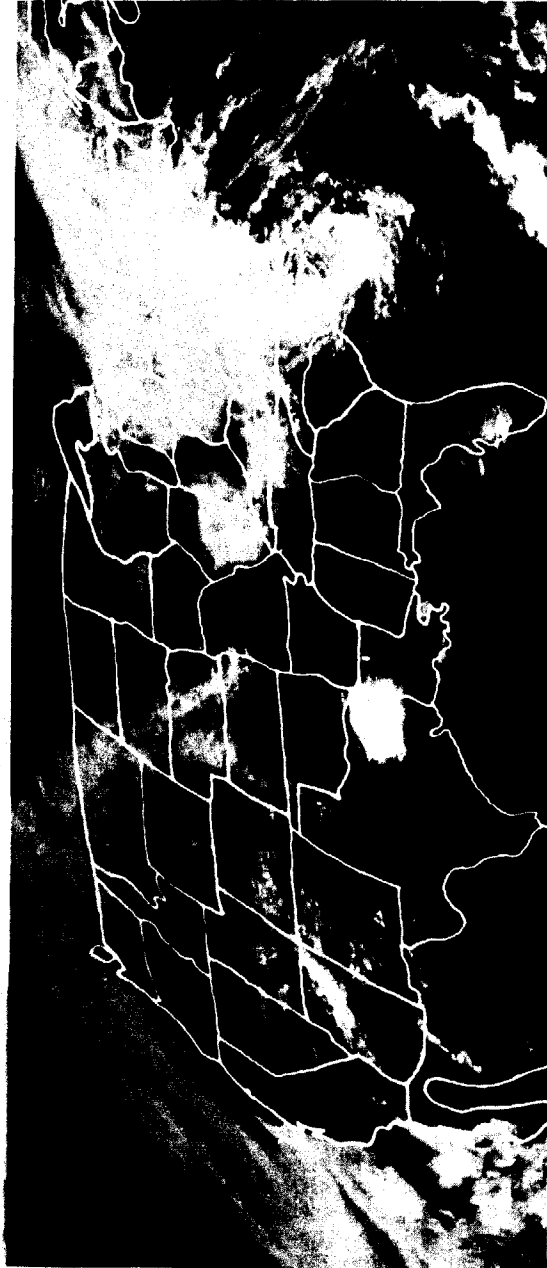

Figure 13. Hurricane Agnes is the most destructive such storm of record. This satellite view shows it as the winds had diminished to the strength of a tropical storm. Inland flooding caused by heavy rainfall was responsible for more than \$3 billion damage and a heavy loss of life.

are drawn in toward this center of low atmospheric pressure from surrounding areas of relatively higher pressure. The movement of air around a storm center has been described in Hurricane, the Greatest Storm on Earth as follows:

At lower levels, where the hurricane is most intense, winds on the rim of the storm follow a wide pattern, like the slower currents around the edge of a whirlpool; and, like those currents, these winds accelerate as they approach the center of the vortex. The outer band has light winds at the rim of the storm, perhaps no more than 30 miles per hour; within 30 miles of the center, winds may have velocities exceeding 150 miles per hour. The inner band is the region of maximum wind velocity, where the storm's worst winds are felt, and where ascending air is chimneyed upward, releasing heat to drive the storm. In most hurricanes, these winds reach 100 miles per hour--and more than 200 miles per hour in the most memorable ones.

Wind damage is likely to be greatest close to where the eye of the hurricane has passed. Moving away from the eye at right angles to the path, the wind velocities tend to diminish and damage decreases proportionately. Since hurricanes have a forward motion the storms do not usually linger in any given place for an extended period of time. While the winds are blowing, however, they may exert great force on structures in their path. Dunn and Miller report the following wind and pressure relationships in their book Atlantic Hurricanes:

WIND SPEED (mph)	PRESSURE per SQUARE FOOT (pounds)
60	15
80	26
100	45
125	78
150	112

With forces such as these being exerted it is not difficult to understand trees being blown over or windows and walls caved in.

In addition to the direct force of the wind on a structure, there is a negative force or suction set up on its lee side. In the case of tall buildings the negative

force may exceed the positive force. Thus, the walls of a building may be pulled outward causing the collapse of the structure. Roofs frequently are damaged because strong winds blowing over them may have the same aerodynamic effect as air blowing over an airplane wing surface and causing lift. Improperly fastened roofs may be lifted off entirely or in part during periods of very high winds. Finally, there is a danger to life and property caused by the debris picked up and carried by the wind. The most common objects of various sizes become deadly missiles under these circumstances.

Hurricane winds have caused a variety of damage during storms on the North Carolina coast and adjoining lands. Structural damage has not only occurred to beach dwellings but also to farm buildings farther inland. In both cases it must be assumed that the losses from wind would have been reduced if the structures had been constructed properly to withstand such forces. Crop damage is caused largely by flooding but winds have had a devastating effect on the corn crop in particular. If a hurricane comes during the latter stages of the growing season, the crop can be blown down (Figure 14). Once on the ground and subjected to soaking rains the corn may become mildewed and useless. Finally, the forests of eastern North Carolina are subject to losses because water-soaked soils resulting from hurricane rains fail to hold tree roots as firmly as drier soils and large numbers of trees may be blown down (Figure 15).



Figure 14. Mature corn in Beaufort County blown down by Hurricane Donna on September 11, 1960.



Figure 15. Blown over trees are often the result of strong hurricane winds in North Carolina's woodlands. This damage was caused by Hurricane Donna in Beaufort County.

In addition to the regular wind pattern around the eye, tornadoes may sometimes accompany a hurricane. This is not a well understood phenomenon nor does it occur in all hurricanes. Studies have indicated that tornadoes usually occur in the forward semicircle of the storm or along the advancing edge. There is no particular time of day favorable to their formation and instances of hurricane related tornadoes have been recorded during all hours of the day and night. While these tornadoes behave much as the more common variety, they are different in that their paths are shorter and more narrow. They are, nevertheless, capable of causing considerable damage. In Hurricane Agnes, for example, some 15 confirmed tornadoes were spawned in Florida resulting in a total property loss of \$4.5 million.

Hurricanes are normal on the North Carolina coast. All parts of the coast are subject to hurricanes even though there may be many years between their occurrences. In recent years property damage has increased as population and construction have increased along the coast. Not only have structures been destroyed by hurricanes

but crops in the mainland counties have regularly suffered damage too. The fact that the loss of life has been kept low is a tribute to the warning system developed by the National Weather Service. For a listing of hurricanes which have hit North Carolina since the turn of the century, see Appendix V.

Northeasters:
Storms of Extratropical Origin

During the winter and spring months, North Carolina experiences a progression of extratropical cyclones--Northeasters--generally moving from west to east across the state. Most people who watch television weather broadcasts are acquainted with the succession of high and low pressure areas and the cold and warm fronts separating them. These are common events in North Carolina and are so ordinary as to hardly excite any special connection with serious problems of coastal erosion. And yet, these cyclones, which have formed outside of the tropics and are usually mild in comparison to hurricanes, do exert a force and are important in shaping the North Carolina coast.

The significance of these northeast storms is not their intensity but their duration. Unlike a hurricane which may pass over a coastal location in a fraction of a day, a Northeaster may blow from the same direction and over long distances for several days. At the very least, this can result in visible beach erosion as the continuous wave energy is dissipated on the shore. At its worst, a Northeaster lasting several days and having gale force winds may create a prolonged storm surge capable of causing great damage. Figure 16 illustrates some of the kinds of damage caused by such a northeast storm in 1973 on Hatteras Island just east of Buxton. During this more intense than usual storm the surge over-topped the island and spilled into the sound in a number of places. The amount of wave action was sufficient to wash out portions of the paved road running the length of the island. In other locations sand was deposited on the road. It is also clear that ocean levels were raised to the extent that structures along the beach were surrounded by breaking waves and were in jeopardy.

An extratropical cyclone is a storm of the middle latitudes. Winds of about 20 miles per hour circulate in the Northern Hemisphere in a counterclockwise direction spirally inward toward a large area of low atmospheric pressure. The entire storm may move across the earth's surface at 20 to 30 miles per hour and it may be as large as 1,500 miles in diameter. Precipitation is usually associated with the passage of such storms. When a deep low is located close to the coastline on



Figure 16. Two days after the northeast storm of February 9-10, 1973, the waters of the Atlantic are still turbulent compared with the relatively calm waters of Pamlico Sound on the left. The town of Buxton lies to the left outside of this scene. Route 12 has been washed out and is not open to traffic (A). Overwash between the Atlantic and the Sound is clearly visible in several places (B). Buildings are standing in the surf (C), and there is evidence that the surf has penetrated farther inland (D).

land or offshore and is moving northward or north-eastward, the wind along the middle and North Atlantic coast blows from the northeast and may reach gale force.

The passage of such low pressure storms is usually followed by cells of higher atmospheric pressure moving generally from west to east. In the Northern Hemisphere the circulation of air around a high is in a clockwise direction outward from the center. Occasionally the location of a high is such that its winds may strike the coast from a northeasterly direction. Precipitation is not associated with this condition, but if the winds are strong and persistent enough the event may be called a "dry Northeaster."

The significance of both types of northeast wind producing systems is not in the damage caused by the winds acting directly on structures or vegetation. The winds are important but mainly because they generate high waves and move them shoreward. It is the action of these waves on the shore and structures close to it that is the chief cause of concern. Studies (Bosserman and Dolan) of extratropical cyclones on the Outer Banks between Nags Head and Cape Hatteras identified 857 storms between 1942 and 1967 with winds strong enough to produce waves sufficient to cause beach erosion. The minimum wave height in deep water capable of causing such erosion was 5.1 feet.

The most active months of the year for Northeasters were December through April according to the study. Each of these months had more than 90 erosion-causing storms for the 25-year period. When averaged out on an annual basis the number of storms per month was as follows:

January	4.3	July	0.8
February	4.4	August	1.2
March	4.9	September	2.2
April	3.8	October	2.6
May	2.0	November	3.0
June	1.5	December	3.6

Both high and low pressure wind generating systems are included in the above list with about 75 percent of the total being identified as extratropical cyclones. Over the 25-year study period winds generating wave heights of over 5.1 feet in deep water occurred on the average of every 10 days. A height of at least 11.1 feet occurred every three months and one of 17.1 feet every three years.

Wave heights of over 23.1 feet occurred once in 25 years.

Probably the worst Northeaster in recent history to strike North Carolina and the rest of the Atlantic coast was the so-called "Ash Wednesday Storm" in March, 1962. One report (Cooperman and Rosendal) described it as follows:

A slow moving late winter coastal storm combined with spring tides (maximum range) wrought tremendous destruction to coastal installations from southern New England to Florida on March 6 to 9. This storm, which consisted of a series of lows, has been described as one of the most damaging extratropical cyclones to hit the United States coastline. Although gale force winds, and at times hurricane force winds, accompanied the storm, this is not unusual for a North Atlantic winter extratropical cyclone. It was the long fetch and the persistence of these strong northeasterly winds which raised the spring tides to near record levels. The tidal flooding which attended this storm was in many ways more disastrous than that which accompanies hurricanes. The storm surge in tropical cyclones generally recedes rapidly after one or two high tides, but the surge accompanying this storm occurred in many locations on four and five successive high tides. In addition to this, many places reported run-up of waves 20 to 30 feet high.

After several days of continuously strong northeasterly winds, the height of waves off the East coast was in excess of 40 feet. Figure 17 shows the distribution of wave heights over the entire Atlantic Ocean on March 8, 1962. The movement of the seas generated by the storm winds is also depicted and it can be seen clearly that the North Carolina coast was being subjected to waves about 30 feet high coming from the northeast. The impact of these forces on our coast was described by Cooperman and Rosendal:

The most destructive effects of the storm took place on Hatteras Island and northward. On the entire stretch to the Virginia line, a large percentage of the protective sand dunes along the ocean side of the elongated islands which constitute the Outer Banks were washed

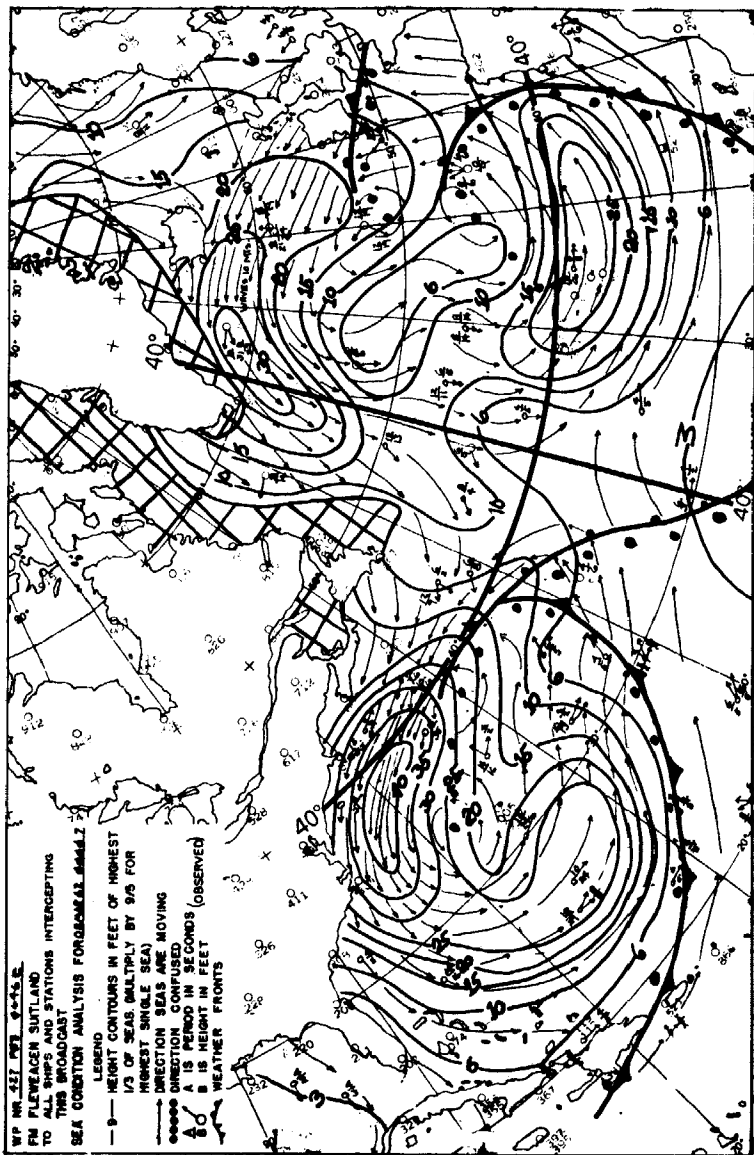

Figure 17. North Atlantic Ocean Sea Condition Analysis Chart of 00:00 GMT of March 8, 1962. Isoleths are significant wave heights in feet. Note the 30-foot wave heights off the Outer Banks.

flat. A 200 foot wide inlet was cut, by waves and strong currents at the change of the tides, across Hatteras Island about two miles north of Buxton. The highway along the shore was destroyed or undermined in many places or covered with sand up to several feet deep. Many cars were stranded with only the rooftops appearing above the sand. Most of the damage to private property occurred in the Kill Devil Hills-Kitty Hawk-Nags Head area north of Oregon Inlet where many motels and summer homes suffered.

Preliminary damage figures are estimated at \$12 million which does not include the devastation to the land itself. Two deaths were reported in North Carolina.

The Ash Wednesday Storm was the most severe Northeaster of recent memory, but many other such storms have occurred in the Twentieth Century. Appendix VI is a listing of some of the most severe of these. It is interesting to note that the storms may originate or be located over land or water and that wind gusts often exceed hurricane force. The effect of the wind on structures is not nearly as important as the action of the waves generated by the wind. These storm-generated waves are listed time after time as having caused considerable beach erosion. With the continued development of beach front property it is likely that public awareness of Northeaster storms as a source of danger will grow.

Surviving It . . . Safely

As we have seen, storms on the Atlantic coast are a potential threat to the people living there. The lives of Atlantic coast residents from New England to Florida are in danger at all seasons of the year when hurricanes and violent Northeasters strike. Even though such storms may seem to be few and far between at any given location, they are a regular feature of life and those living on or near the coast should be prepared to cope with them. In the final analysis it is up to the individual to know what to expect, how to prepare for and how to survive such storms. At the very least, one member of each coastal family should become acquainted with the facts in order to serve as leader during such emergencies.

In the earlier years of this century hurricanes and severe Northeasters struck with little or no prior warning being provided to the inhabitants. The science of meteorology has made great strides, however, and our understanding of these storms and their movements has grown. Electronic communications also have become increasingly sophisticated. Efficient radios and television receivers are to be found everywhere. News of threatening storms can be heard on home, automobile, boat and pocket radios. The National Weather Service has developed an extensive and integrated communications network within the organization and with the public. The development of radar, weather satellites and hurricane hunter aircraft have vastly improved the ability to detect and track hurricanes while they are still far at sea. The outcome of these achievements has been a system which provides timely warning and accurate information about storms to people at home, work or play. The surprise storm appears to be a thing of the past.

The Warnings

The National Hurricane Center in Miami, Florida, gathers and interprets information about Atlantic tropical weather disturbances from many different sources. If a disturbance intensifies to tropical storm strength and appears to be headed toward land, the Center will begin to issue advisories. These may be picked up by the news media and made available to the public. Occasional bulletins may also be issued to further amplify the routine

information provided by the advisories. As the storm reaches hurricane strength and is headed toward the United States coastline a hurricane watch may be issued from the National Hurricane Center or one of several other offices located in San Juan, New Orleans, Washington and Boston. Once the area of hurricane landfall is more positively identified, and the storm is expected to come ashore in 24 hours or less, a hurricane warning is issued. Areas of the coast for which such a warning has been issued may expect dangerous hurricane winds or storm surge to strike. As the storm comes very close to shore the nearest National Weather Service office may issue local statements. These are designed to provide specific information about the anticipated affects of the storm for individual counties. Areas to be evacuated are identified and information is provided for the protection of life and property.

Radio and television are the important links between the National Weather Service and the public in storm situations. The entire warning system is designed to keep people informed of impending danger so that no one will be caught unawares. As a hurricane approaches the coast, the local government may advise evacuation. This information will normally reach the public over radio or television. In some cases emergency workers may go from door to door to be sure that people are warned.

Coastal dwellers should have at least one battery-powered radio in every household in order to keep informed in the event of a loss of power due to the storm. In addition to the standard portable radios receiving AM and FM broadcasts, there are now special weather radio receivers on the market. These are designed to pick up continuous weather broadcasts by National Oceanic and Atmospheric Administration stations around the country. There are three such stations currently in operation on the North Carolina coast: Cape Hatteras, 162.55 MHz; New Bern, 162.40 MHz; and Wilmington 162.55 MHz. These stations broadcast weather information seven days a week and 24 hours a day. Their range is about 40 miles. Six new stations were scheduled to go into operation in the Fall of 1978 near Fayetteville, the Research Triangle area, Rocky Mount-Wilson-Tarboro, Charlotte, the Triad area and Asheville.

Evacuation

In the event that a call for evacuation is issued there are certain procedures to be followed until the

emergency is over. The following suggestions have been published as a part of the county Evacuation Plans (see Appendix I) prepared by local officials in cooperation with the North Carolina Division of Civil Preparedness.

1. Shut off main gas valve and pull main power switch before leaving home.
2. Head for the designated shelters or evacuation points indicated for your area, as directed on your Evacuation Plan maps and by broadcasts during the emergency. Follow routes indicated on maps. Drive up to shelter entrance, unload, and park car as police instruct. /In some cases buses will be provided./ If on foot, proceed to nearest loading station and board buses. No fare will be charged.
3. Take only clothing, food and special medicine that is necessary; do not try to bring household equipment. Evacuated areas will be policed to prevent looting.
4. Follow instructions of shelter personnel, and volunteer to help with any tasks needed for efficient shelter operation.
5. Remain at the shelter until informed that you may leave. People will not be allowed back into evacuated areas until advised by official public announcement.

Safety Rules

The National Oceanic and Atmospheric Administration (NOAA) has published the following list of safety rules indicating how people should respond to broadcast information about a hurricane at all stages of the storm. The emphasis is on action which individuals should take to protect their lives and property. Most of these same rules apply equally in situations along our coast when severe northeast storms strike during the winter and spring months.

1. Enter each hurricane season prepared. Every June through November, recheck your supply of boards, tools, batteries, nonperishable foods, and the

other equipment you will need when a hurricane strikes your town.

2. When you hear the first tropical cyclone advisory, listen for future messages; this will prepare you for a hurricane emergency well in advance of the issuance of watches and warnings.
3. When your area is covered by a hurricane watch, continue normal activities, but stay tuned to radio or television for all National Weather Service advisories. Remember: a hurricane watch means possible danger within 24 hours; if the danger materializes, a hurricane warning will be issued. Meanwhile, keep alert. Ignore rumors.
4. When your area receives a hurricane warning:

Keep calm until the emergency has ended.

Plan your time before the storm arrives and avoid the last-minute hurry which might leave you marooned, or unprepared.

Leave low-lying areas that may be swept by high tides or storm waves.

Leave mobile homes. They are extremely susceptible to high winds and storm tides. Damage can be minimized by securing mobile homes with heavy cables anchored in concrete footing.

Moor your boat securely before the storm arrives, or evacuate it to a designated safe area. When your boat is moored, leave it, and don't return once the wind and waves are up.

Board up windows or protect them with storm shutters or tape. Danger to small windows is mainly from wind-driven debris. Larger windows may be broken by wind pressure.

Secure outdoor objects that might be blown away or uprooted. Garbage cans, garden tools, toys, signs, porch furniture, and a number of other harmless items become missiles of destruction in hurricane winds. Anchor them or store them inside before the storm strikes.

Store drinking water in clean bathtubs, jugs, bottles, cooking utensils; your town's water supply may be contaminated by flooding or damaged by hurricane floods.

Check your battery-powered equipment. Your radio may be your only link with the world outside the hurricane, and emergency cooking facilities, lights and flashlights will be essential if utilities are interrupted.

Keep your car fueled. Service stations may be inoperable for several days after the storm strikes, due to flooding or interrupted electrical power.

Stay at home, if it is sturdy and on high ground. If it is not, move to a designated shelter, and stay there until the storm is over.

Remain indoors during the hurricane. Travel is extremely dangerous when winds and tides are whipping through your area.

Monitor the storm's position through the National Weather Service advisories.

Beware the eye of the hurricane. If the calm storm center passes directly overhead, there will be a lull in the wind lasting from a few minutes to half an hour or more. Stay in a safe place unless emergency repairs are absolutely necessary. But remember, at the other side of the eye, the winds rise very rapidly to hurricane force, and come from the opposite direction.

5. When the hurricane has passed:

Avoid loose or dangling wires, and report them immediately to your power company or the nearest law enforcement officer.

Seek necessary medical care at Red Cross disaster stations or hospitals.

Stay out of disaster areas. Unless you are qualified to help, your presence might hamper first-aid and rescue work.

Drive carefully along debris-filled streets. Roads may be undermined and may collapse under the weight of a car. Slides along cuts are also a hazard.

Report broken sewer or water mains to the water department.

Prevent fires. Lowered water pressure may make firefighting difficult.

Check refrigerated food for spoilage if power has been off during the storm.

Remember that hurricanes moving inland can cause severe flooding. Stay away from river banks and streams.

What's Safe to Eat and Drink?

At the beginning of each hurricane season in May or June, people living on the coast should prepare a supply of emergency food. It should be large enough to feed the members of the household for several days. A variety of non-perishable canned foods not requiring refrigeration is best for the purpose. Canned fruit juices should be included in case the normal flow of drinking water is interrupted. If the emergency food is not used during the hurricane season, it can be used as a part of the regular food supply during the winter. At the start of the next storm season, a fresh supply of emergency food should be stocked.

The following information about water and food during an emergency is taken from the Disaster Handbook for Extension Agents published by the Cooperative Extension Service of the Pennsylvania State University.

Sources of Drinking Water

One of the most crucial needs is a supply of safe water. Everyone needs at least two quarts of water or other liquids daily (more in hot weather). Pure water may be needed also for preparing food, brushing teeth, and keeping clean.

When warned of a severe storm which could cause flooding, or which could otherwise disrupt water services, insure an adequate supply of safe water for your family by filling large clean containers, pots, pans, sinks, and bathtubs with water. Then shut off the main water valve to protect the clean water already in your water system, and close the valves on the water lines leaving the house.

You may have emergency sources of water, such as ice cubes, on hand. Soft drinks and fruit juices are water substitutes. In addition, the water in water pipes and toilet flush tanks (NOT THE BOWLS) is safe to drink if the valve on the main water line was closed before the flood.

To use the water still in the pipes, turn on the faucet located in the highest point in the house--usually in an upstairs bathroom. This lets air into the system. Then draw water from the lowest faucet in the house.

The hot water heater or water pressure tank could supply many gallons of safe water in an emergency. Before using water from the water heater, switch off the gas or electricity which heats the water. Leaving the heating part on while the heater is empty could cause an explosion or burn out the elements. After turning off the gas or electricity, open the drain valve at the bottom of the tank. Do not turn the water heater on again until the water system is back in normal service.

Purifying Water

Unless you are absolutely certain your home water supply is not contaminated by flood water, purify all water before using it for drinking, food preparation, brushing teeth or dishwashing. If the water contains sediment or floating material, strain it through a cloth before treating it. Water can be purified by boiling or by chemical treatment.

Boiling

Boil water at a rolling boil for 10 minutes to kill any disease-causing bacteria in the water. Add a pinch of salt to each quart of boiled water to improve the taste.

Chemical Treatment

If water cannot be boiled, treat it chemically. Two chemicals usually found in the home will purify water.

Household bleach is a good disinfectant for water. However, check the label to be sure that hypochlorite is the only active ingredient in the bleach. Do not use any bleach which contains soap.

<u>Percent chlorine</u>	<u>Add per gallon of water</u>
1%	40 drops
4 to 6%	8 drops
7 to 10%	4 drops
Unknown	10 drops

Mix the bleach thoroughly into the water. Let it stand for 30 minutes. The water should have a slight chlorine odor. If it doesn't, repeat the dose and let the water stand for an additional 15 minutes.

Household iodine from the medicine chest or first aid kit also will purify water. The iodine should be 2 percent United States Pharmacopeia (U.S.P.) strength. Add 20 drops per gallon of clear water, and 40 drops per gallon of cloudy water.

Water purification tablets also will purify water. Follow manufacturer's directions. Water purification tablets are available at drugstores.

Preparing Food During a Power Failure

During a power failure, cooking and eating habits must change to fit the situation. You may have no heat, no refrigeration, and limited water. In addition, health risks from contaminated or spoiled food may increase.

Conserve Fuel

Consider the amount of cooking time needed for particular foods. If you have limited heat for cooking, choose foods which cook quickly. Prepare casseroles and one-dish meals or serve no-cook foods.

Alternative cooking methods include:

- Fireplace. Many foods can be skewered, grilled or wrapped in foil and cooked in the fireplace.
- Electric utensils. If gas is cut off, but you still have electricity, use electric skillets, hot plates or coffee makers to heat food.
- Candle warmers and other devices such as fondue pots may be used if no other heat sources are available. Use safety precautions with these devices. Never use fuel-burning camp stoves or charcoal burners inside your home, even in a fireplace. Fumes from these stoves can be deadly.

Do not cook frozen foods unless you have ample heat for cooking. Most frozen foods require considerably more cooking time and heat than canned goods. Also, if power is off, it is best to leave the freezer door closed to keep food from thawing.

Conserve Water

Save liquids from canned vegetables. Substitute these for water in cooked dishes. Drain and save juices

from canned fruits. Substitute these for water in salads and beverages.

Observe Health Precautions

Boil all water used in food preparation for at least 10 minutes.

If you are without refrigeration, open only enough food for one meal. Some foods can be kept a short time without refrigeration. Cooked vegetables, meat and meat dishes can be kept unrefrigerated from noon until the evening meal. Do not keep these dishes overnight without refrigeration.

Do not serve foods that spoil easily, such as ground meats, creamed foods, hash, custards, meat pies and any food containing mayonnaise. These are potential sources of botulism poisoning.

If necessary, substitute canned and powdered milk for fresh milk. Canned milk will keep safely for a few hours after you open the can. If you are using canned milk to feed a baby, however, open a fresh can for each bottle. Use only boiled or disinfected water to mix powdered milk. Use powdered milk immediately after it is mixed.

If safe water or water disinfecting material is not available, use canned or bottled fruit juices instead of water.

Prepare and eat foods in their original containers, if possible. This will help if dishwashing facilities are limited.

Contaminated Foods

Contaminated food may be a problem following any storm involving flooding.

Flood waters may carry silt, raw sewage, oil, or chemical wastes. Filth and disease bacteria in flood water will contaminate food, making it unsafe to eat.

Inspect any food left in the house after a flood. Flood water may have covered it, dripped on it, or seeped into it. Even though some foods (see below)

are protected by their containers, if you are in doubt about the safety of a food, throw it out rather than risk disease.

Use the following guidelines when deciding which foods to discard and which to save.

Food to Discard

Do not attempt to save the following foods:

- Opened containers and packages which have come in contact with flood waters;
- Unopened jars and bottles with paper seals such as those containing mayonnaise or salad dressing;
- Containers of spices, seasonings, and flavorings;
- Flour, sugar and coffee in canisters;
- Paper, cloth, fiber or cardboard boxes, even if the contents seem dry. This includes salt, cereals, pasta products, rice and "sealed" packages of crackers or cookies within a larger paper box;
- Dented, bulging or leaking tin cans. Cans which have been tossed about and are found far from their normal storage spot. Seams on these cans may have been weakened or their seals broken, causing contamination or spoilage;
- Jam or jelly sealed with paraffin;
- Containers with non-sealed, fitted lids, such as cocoa or baking powder;
- Commercially bottled carbonated beverages, if the cap is crusted with silt;
- Foil or cellophane packages;
- All fresh vegetables and fruits which do not have a peel, shell or coating which can be removed before use; leafy vegetables;
- Fresh meat, fish and poultry which have been in contact with flood waters;
- Home canned foods, even if the jar seems tightly sealed. (However, in some cases, tightly sealed home canned foods may be safe, depending on the flood conditions. If your supply of canned food is extensive, contact a food preservation specialist, who can advise you after learning specific facts about flood conditions.)

Food to Keep

The following foods are safe if you wash and sanitize containers before use; or wash, sanitize and peel fruits or vegetables:

- Undamaged tin cans. For added safety boil food before using. Be sure to wash and sanitize container (see below) before opening the can.
- Potatoes. Wash, sanitize, dry, peel, and cook before using.
- Citrus fruits. Wash well, sanitize, and peel before using.
- Apples and other fruits which can be sanitized, peeled and cooked before eating. Do not eat raw fruit, even if it has been sanitized.

To Disinfect Cans and Commercial Glass Jars

All cans and commercial glass jars must be washed and sanitized before they are opened.

Remove labels and wash in a strong detergent solution with a scrub brush. Remove all silt.

Immerse scrubbed containers for 15 minutes in a chlorine solution. Household bleaches contain from 2 percent to 6 percent chlorine. The amount of bleach to add to water would depend on the percent chlorine it contains:

<u>% chlorine in bleach</u>	<u>Volume of bleach to add to 1 quart water</u>	<u>Volume of bleach to add to 1 gallon water</u>
2%	3/4 tablespoon	2 tablespoons
4%	1 teaspoon	1 tablespoon
6%	1/2 teaspoon	3/4 tablespoon

Remove containers from solution, and air-dry before opening. Re-label if possible. Use as soon as possible, since containers may rust. Store containers where they will not be re-contaminated.

To Disinfect Fruits and Vegetables

Wash in a strong detergent solution with a scrub brush. Remove all silt. Soak in a chlorine solution for 15 to 20 minutes. (See table above for strength of chlorine.) Rinse thoroughly with safe drinking water. Peel if possible, and cook thoroughly before eating. Refer any specific questions to health authorities or your county extension agent.

Keeping a Roof Over Your Head

One important way engineers have learned proper construction methods of coastal dwellings is through experience. They have examined buildings which survived hurricanes and analyzed their components and types of construction. The buildings which were destroyed also have been examined and their weaknesses identified. Such studies have greatly contributed to knowledge of sound construction capable of withstanding the forces of wind and water unleashed by hurricanes and other severe coastal storms.

Engineers of the Forest Service of the US Department of Agriculture (USDA) conducted a survey of damage to buildings in the path of Hurricane Camille. On the night of August 17, 1969, this most violent hurricane ever to strike the US mainland made landfall on the Mississippi coast with winds up to 190 miles per hour. Severe wind damage was experienced on the coast and inland over an area 40 miles wide by 80 miles long. Hattiesburg, Mississippi, located 73 miles from the coast experienced winds of up to 100 miles per hour. The combination of wind and storm surge caused devastation on the Mississippi coast while further inland winds and rain were mainly responsible for the damage to structures.

The examination of damage throughout the area where the storm was at its most severe resulted in the collection of many valuable observations dealing with materials and construction methods. "Wood Structures Survive Hurricane Camille's Winds," was subsequently published as USDA Forest Service Research Paper FPL 123 in October, 1969, just weeks after the hurricane. The summary of the findings of the survey team was as follows:

Well-built conventional wood-frame construction performed exceptionally well in Hurricane Camille, except when subjected to severe wave action. Wood-frame houses, in particular, exhibited remarkable resistance to the high winds. Apparently conventional construction whose components are well attached to each other is adequate to resist the wind forces in hurricane zones.

However, conventional construction of any type on solid foundations is not adequate to resist the severe tide and wave actions along coastlines during hurricanes. Much

of the damage to the coastal buildings done by Hurricane Camille would probably have been avoided if high pier type foundations had been used to reduce the force of water directly on the buildings. This type of foundation also would have greatly reduced property damage from flooding further inland.

Damage to wood-frame homes from wind appeared to be less for those homes with hip roofs than with gable-end roofs. Most hip roofs that were observed lost fewer shingles and did not have the roof sheathing and rake damage common to houses with gable-type roofs.

Mobile homes were treated badly by Hurricane Camille, as they were by previous hurricanes. Mobile homes overturned by the wind were generally complete losses. Buildings of lightweight construction, as mobile homes, should be adequately anchored in hurricane or high wind zones. We believe that much of the wind damage to mobile homes could be avoided by anchoring them to an economical wood pier-type foundation.

Any person considering building in coastal areas should pay special attention to the need for proper fastening between the component parts and also the use of pilings to raise the building above ground level. An excellent source of information to the builder is Research Paper, FPL 33, of the US Forest Service, published in August, 1965, and entitled "Houses Can Resist Hurricanes." It can be ordered from Forest Service, USDA, Forest Products Laboratory, Madison, Wisconsin. This publication contains clear illustrations and descriptions of construction techniques which should result in storm resistant structures. Figures 18 and 19 are just two of many appearing in the publication and are included here as an indication of the detail provided. In recent years a number of other pamphlets from various sources have been published on the subject of construction techniques to be used in building storm resistant structures. The reader will find these listed in the references at the end of this book. These publications also may provide helpful information for improving storm resistance in existing buildings.

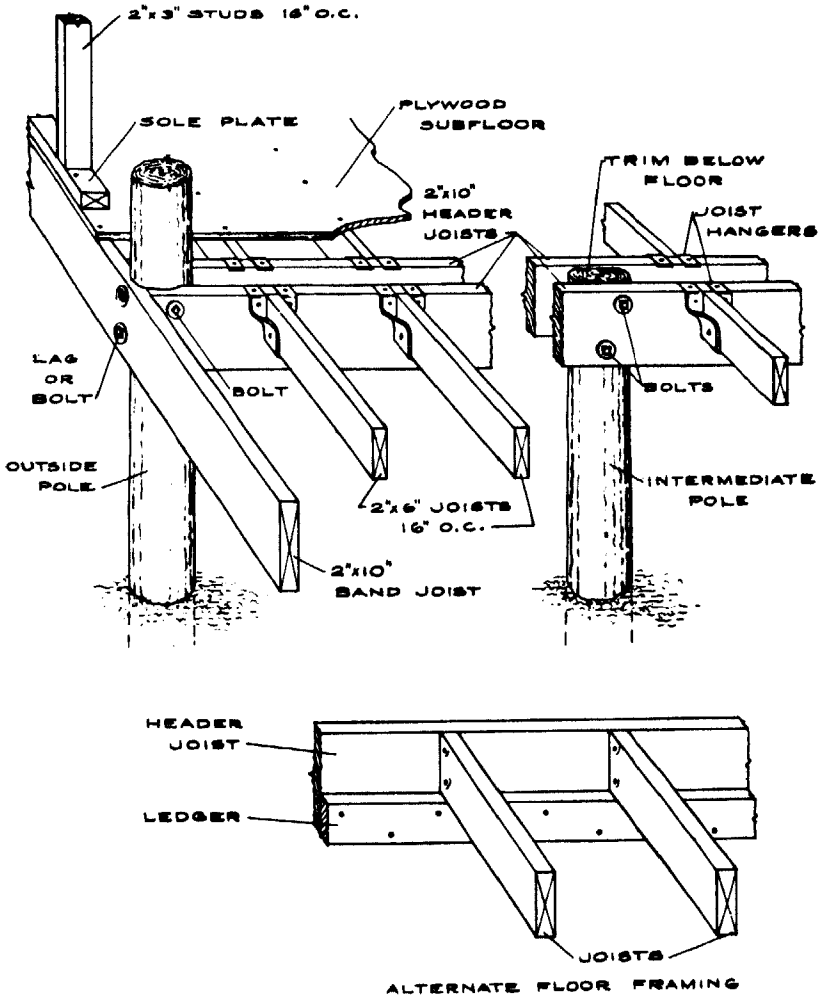

Figure 18. Floor framing methods in constructing a storm-resistant pole house.

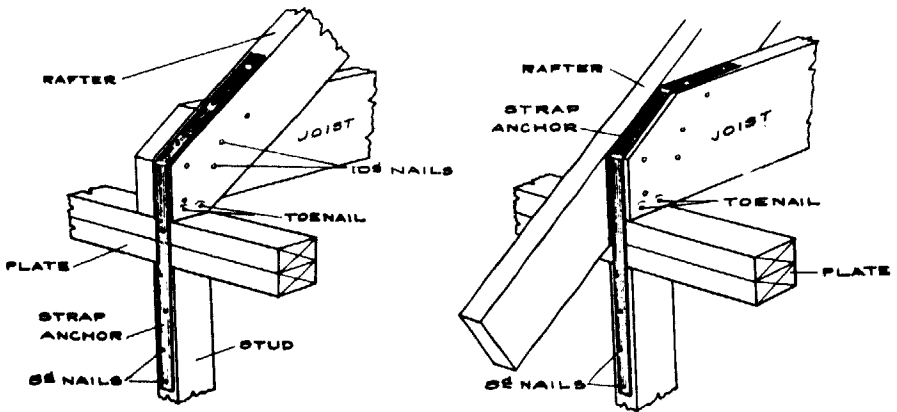
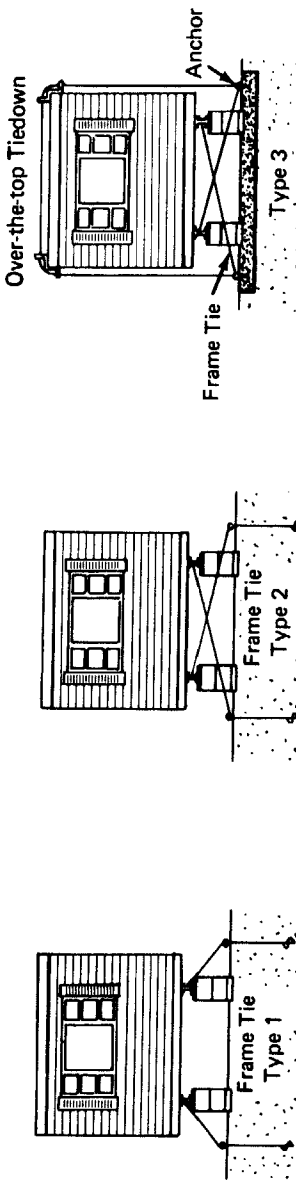

Figure 19. Details of construction showing two ways to make roofs more secure and wind resistant.

There are many mobile homes in use in the coastal counties of North Carolina and, under hurricane and other high wind conditions, they present special problems. Their construction is lightweight and their sides are usually flat and this makes them especially vulnerable to being rolled over or moved around by high winds. When this happens a mobile home may be completely destroyed. But there are several ways of protecting mobile homes against high winds. If there is sufficient room on the lot, the mobile home may be positioned so that its end will face the prevailing winds and present minimum resistance to them. The local office of the National Weather Service should be able to provide information about prevailing winds, and indicate if they are an important factor. A second type of protection is provided by trees which form a natural windbreak. The more dense the stand of trees around the mobile home the greater the protection, even though there may be some danger from falling limbs. Finally, and most importantly, is the proper anchoring of mobile homes by means of tiedowns.

The use of tiedowns is becoming widespread and some manufacturers are including built-in tiedown straps underneath the skins of newer mobile homes. This important safety device can be added to mobile homes of any age. Figure 20 shows some of the details of how this is done. This plate was taken from a publication



These sketches illustrate various methods for connecting frame ties to the mobile home frame. Type 2 system can resist greater horizontal forces than Type 1. Type 3 system involves placement of mobile home on concrete slab. Anchors embedded in concrete slab are connected to ties.

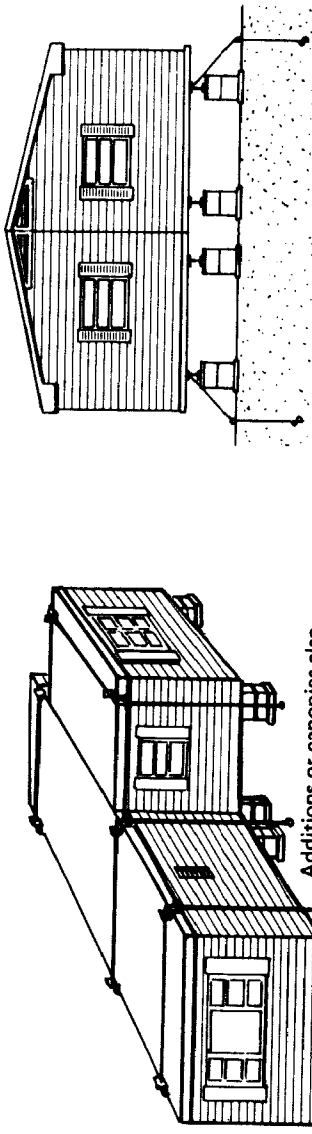

Additions or canopies also need to be secured with over-the-top tiedowns.

Double wides do not require over-the-top tiedowns but are subject to the same frame tie requirements presented on page 8.

Figure 20. Tiedown plans for several types of mobile homes.

all mobile home owners should have. The title is Protecting Mobile Homes From High Winds, TR-75, published by the Civil Preparedness Agency, Department of Defense, in February, 1974. Copies may be obtained from local Civil Preparedness officials or ordered from the Superintendent of Documents, US Government Printing Office, Washington, D.C. 20402. It should be ordered by the Government Printing Office stock number 008-030-00013-8. The cost is 70 cents per copy.

Even though all precautions have been taken to make a mobile home as wind resistant as possible, the occupants should seek more solid shelter when warnings of severe wind storms are issued.

Boating It

Boat owners who are on the coast as a hurricane is approaching will receive ample warning through the advisories and bulletins of the National Weather Service. All boats, no matter what their size, should have some sort of radio aboard even if it is only a small transistor set capable of receiving commercial broadcasting stations. In this way the boat owner can remain aware of general weather conditions. At the first indication of possible danger the boater should return to shore. Next, he should decide what to do with the boat to ensure that it will survive the storm undamaged.

There are a number of actions the boater can take. Facilities and time permitting, large boats should be put in dry storage. If the boat is trailerable it should be pulled out of the water at a ramp and moved out of the area at the same time the boater is moving inland to a safer location.

Should a boat owner find himself without sufficient time to get his boat out of the water, these suggestions by Talbot F. Hamlin will help. They appeared in an article entitled "When You Get Caught-Things That Will Help in Squall or Hurricane" published in Yachting, October, 1955.

1. Know a good hole and go there in time.
2. Be sure you have on board adequate anchors, enough rode (at least one should be 250 feet or longer), and plenty of docking lines of sufficient length and diameter.
3. Keep your gasoline tanks full and your engine in good running condition at all times. You don't know when a sudden emergency may make it invaluable.
4. If you are at a pier, get on the lee side, be careful of your docking lines, and, in the case of hurricanes, judge if the piles are high enough.

If not, leave the pier and anchor in the safest place you can find (or, if you have to, run free).

5. Get your engine running when emergency threatens. Then leave it out of gear or put it in gear, as conditions indicate.
6. Keep your mooring slack, but take care not to override it. If you are using power when at anchor, be careful not to have so much slack in the anchor rode as to create a danger of fouling it in your propeller.
7. Have plenty of chafing gear, and use it.

With these precautions a modern vessel can face squalls and gales confidently with a good promise of coming through undamaged, and with crew tired, perhaps, but alive and well.

If a boat has been removed from the water on its trailer but will not be hauled away there are some precautions which might be followed. The boat should be covered with a canvas so that it will not fill with rain water. Whether it is covered or not, the plug should be pulled to ensure that any water will drain from the interior. Both boat and trailer may be secured with lines to some substantial object to prevent movement by the wind.

In the case of a small boat which must be left out of doors during a storm it is best to move it to high ground and turn it bottom up. It should be secured to solid objects or, if there are none at hand, metal rods can be driven into the ground and the boat tied to them.

If the owner of a larger boat finds himself in a crowded anchorage he may wish to utilize a three anchor mooring system. This consists of three lightweight anchors placed equidistant from each other around a center point and 120 degrees apart. The anchors are bridled to a common center. A chain and pennant from that center provide a point to which the boat with a short rode can be tied up. The boat is free to swing through a small circle and, no matter what the direction of the wind, there will always be one or two anchors to windward holding it. This system has proven to be very effective under severe weather conditions.

Above all, once a boat has been moored as securely as possible, the boat owner should leave it and not attempt to return to it until after the wind and waves have subsided.

On the Farm

The low-lying eastern counties of North Carolina are predominantly rural. Hurricanes coming ashore and moving inland frequently have caused damage to farm property and crops in this part of the state. The damage may be caused by high winds or by flooding. In areas close to the sound shores flooding may be the result of storm surges in the sounds. Elsewhere, flooding may be the result of heavy rainfall associated with the storms.

The following information for farmers is taken from the Disaster Handbook for Extension Agents published by the Cooperative Extension Service of Pennsylvania State University.

Protecting Farm Buildings From Severe Winds

High winds can damage farm buildings. The following procedures are recommended to help protect buildings during severe windstorms.

- Securely close all doors and windows. Try to determine whether the buffeting and force of the wind will break fasteners or hinges. Nail doors and windows shut, if necessary. If the building is tight, open windows slightly on the side away from the wind to help equalize pressure.
- Nail plywood or boards over large windows and windows with weak sashes.
- Brace large barn doors and weak walls. Use interior braces on the windward side, and exterior braces on the side away from the wind. If you are uncertain about the direction of the wind, use both interior and exterior braces. Place braces on the reinforced section of the door or wall to distribute the bracing effect over a larger area.
- Check that roof rafters are securely fastened to wall studding. Use 2 inch by 2 inch metal plumber's straps or 2 inch by 6 inch knee braces to secure rafters, if necessary.
- Check metal roofing and siding for loose nails. If nails don't tighten when hammered back in, pull them out, use a #12 or #14 metal screw to fill the hole, and re nail 3 to 4 inches away; eaves should be nailed every 5 inches.

- Do not use heavy machinery to anchor small buildings. Replacing machinery could be more expensive than replacing a building.

Protecting Livestock During a Flood

Livestock not in a confined area usually can take care of themselves during floods. Do not let them become trapped in low-lying pens.

In broad, level flood plains where flood waters are seldom deeper than 3 or 4 feet, construct mounds of soil on which livestock can stay until flood waters recede. Or carry bales of hay for hogs to climb on. Try to locate these mounds where they will not be washed away by fast-flowing water.

- Provide feed and water. Water is essential. Thirsty animals will try to break out to get to flood waters. If water is in short supply, limit feed intake.
- If animals are housed with machinery, fasten bales of straw in front of sharp edges and protruding parts such as cutter bars or crank handles. (Do not use hay, because animals will eat it.) Try to cover wooden paddle wheels on combines or choppers, since these parts can be dangerous if partially broken.
- Block off narrow passageways where animals would be unable to turn around. A few heavy animals in a narrow dead end can be dangerous both to themselves and the building.
- Be absolutely certain that herbicides, pesticides, and treated seeds are not even remotely accessible to livestock, and are stored where flood water will not contaminate livestock feed or water.
- Turn off electricity at the main switch. Livestock could damage electric fixtures, causing fires or electrocutions.
- If there is a possibility that dairy barns may become inundated, drive cattle out of the barn. During rapid rise of water, cattle often refuse to leave the barn and may drown if the water rises high enough in the barn.

Preparing to Evacuate--What to Do on Your Farm

Insure family safety first. Be certain you have enough time to get to higher ground before access is cut off. If you have time before you receive an evacuation order, the following precautions may help protect farm buildings, livestock and equipment from flood damage.

- Move machinery, feed, grain, pesticides and herbicides to higher elevations.
- Construct mounds of soil for livestock, or open gates so livestock can escape high water. Small numbers of hogs can sometimes be saved by bringing them bales of hay to climb on.
- Animals swim well. The greatest problem for grazing animals will be fences and other obstacles. Try to drive stock through water free of obstructions. Long swims through calm water are safer than short swims through a swift current.
- Leave building doors and windows open at least 2 inches to equalize water pressure and help prevent buildings from shifting.
- If possible, move motors and portable electric equipment to a dry location.
- Disconnect electric power to all buildings which may be flooded. If in doubt about how to disconnect power, call your utility company.

Dairymen who anticipate extensive flooding should:

- Check with a veterinarian to be sure cattle are properly immunized before being exposed to flood waters;
- Check with the Department of Health concerning approval of temporary milking facilities;
- Try to obtain standby equipment or services for emergency milk pickup;
- When possible, move grain out of reach of flood water.

Tie down lumber, logs, irrigation pipes, fuel tanks and other loose equipment or material.

Prepare immovable power units and machinery for flooding:

- Seal radiator openings (tighten caps and plug overflow);
- Remove air cleaners and carburetors; seal openings. Use material strong enough to withstand water pressure;

- Fill oil reservoirs. Plug breather pipes and openings;
- Fill bearings with fresh lubricant;
- Protect open gears, sprockets, pulleys and wearing and cutting edges of machinery with lubricant or rust inhibitor;
- Drape polyethelene sheeting over bell ends of motor. Tie securely with cord on cylindrical part of motor housing, or fasten with a strong rubber band.

Safety of Flooded Garden Produce

If flood waters have covered a garden, some produce will be unsafe to eat. The safety of unharvested fruits and vegetables will depend on:

- kind of produce;
- maturity of produce at the time of flooding;
- time of year flooding occurred;
- severity of flooding (depth of water and silt);
- duration of flooding;
- bacterial content of floodwater;
- likelihood of contamination from sewage or other bacterial contaminants.

Immature Produce

In general, fruits and vegetables which were immature at the time of flooding should be safe to eat by the time they are ready for harvest. For additional safety, disinfect produce (see below) and cook it before eating.

Mature Produce

Unless flooding was light and there is no danger of bacterial contamination from floodwater, avoid using fruits and vegetables that were ready for harvest at the time of flooding, unless they can be disinfected, peeled and thoroughly cooked. Some fruits and vegetables are more susceptible than others to bacterial contamination.

- Leafy vegetables such as lettuce, cabbage, mustard, kale, collards, spinach, swiss chard, celery and fleshy vegetables and berry fruits such as tomatoes, summer squash, strawberries and peppers would be highly susceptible to bacterial contamination. Silt and other

contaminants might be imbedded in the leaves, petioles, stems or other natural openings of fleshy structures, and could be difficult to remove.

- Root, bulb and tuber crops such as beets, carrots, radishes, turnips, onions and potatoes would be less susceptible to bacterial contamination. Disinfect these vegetables, peel and cook them thoroughly before eating.
- Produce with a protected fruit or impervious outer skin such as peas, melons, eggplant, sweet corn or winter squash should be washed and disinfected before the outer shell, skin or husk is removed. Then shell, peel or husk the produce, and cook it if possible.

Disinfecting Measures

Thoroughly wash and disinfect any produce before eating.

- Wash in a strong detergent solution with a scrub brush. Remove all silt.
- Immerse produce for 15 to 20 minutes in a chlorine solution. Household bleaches contain from 2 percent to 6 percent chlorine. The amount of bleach to add to water depends on the percentage chlorine it contains:

<u>% chlorine in bleach</u>	<u>Volume of bleach to add to one quart water</u>	<u>Volume of bleach to add to one gallon water</u>
2%	3/4 tablespoon	2 tablespoons
4%	1 teaspoon	1 tablespoon
6%	1/2 teaspoon	3/4 tablespoon

- Rinse thoroughly with safe drinking water.
- Peel, if possible, and cook thoroughly before eating. Refer any specific questions to health authorities or your county extension agent.

Disposing of Sewage and Garbage

Damaged sewage systems are health hazards. It is important to get damaged septic tanks, cesspools, pits and leaching systems into service as soon as possible.

If the area has been flooded, you should wait until the water level recedes before using sewage system.

Trained personnel in local and state health departments will help with these problems. They will be able to advise you about cleaning, repairing and relocating installations, if necessary. Problems with water purity, waste disposal, or pest control should also be referred to them.

Septic Tanks

Most septic tanks will not be damaged by a flood, since they are below ground and completely covered. However, if the tank has been damaged and is filled with silt and debris, it must be cleaned. Use a shovel or sewage pump to clean the tank.

Do not use the sewage system until water in the disposal field is lower than water level around the house.

If tile lines in the disposal field are filled with silt from floodwater, install a new set of lateral tile or perforated pipe in new trenches. Dig the new trenches alongside the old tile lines. Install the tile or pipe according to septic tank system installation specifications. The recommended normal grade is from 2 to 4 inches per 100 feet. Do not use the sewage system until new tiles are laid.

It may be necessary to wait a few days before returning a septic tank system to normal use. It will take some time for water to evaporate from saturated soil, so that the tile field will be able to function again. Septic tank starter materials such as yeast enzymes or horse manure will not be needed.

Temporary Sanitation

Until sewage disposal systems are back in normal working order, use any large container with a tight-fitting lid for a temporary toilet. Line the container with a plastic bag. After each use, add chlorine bleach or disinfectant to stop odor and kill germs.

A chemical camper's toilet will be quite useful in disaster situations.

Garbage

Try to remove garbage as soon as possible to prevent rat infestations and other health problems. Some garbage can be burned. Bury garbage that will not burn. Dig a hole 4 or 5 feet deep, and cover garbage with at least 18 inches of soil.

Disposing of Animal Carcasses

Prompt and sanitary disposal of animal carcasses is necessary to protect the living animals in an area from disease. Search all pastures for dead animals as soon as possible. Carcasses may have some commercial value, so send them to a rendering plant if possible. If rendering is impractical, dispose of the dead animals on the premises. Use the following procedures:

- Immediately after finding a carcass, cover it with crude oil or kerosene to keep away dogs, buzzards and vermin.
- Fat swine are the only animal carcass that will burn satisfactorily. Used railroad ties can be used as starters.
- Bury other carcasses. Use power equipment if it is available. Choose a site where subsurface drainage will not reach water supplies. Bury the carcasses at least 3 to 4 feet deep, so predatory animals won't be able to reach them. If quicklime is available, cover carcasses with it before back filling. Quicklime will hasten decomposition.

Appendix I

CIVIL PREPAREDNESS INFORMATION

In North Carolina the headquarters for the state-wide Division of Civil Preparedness is located in the Administration Building, 116 West Jones Street, Raleigh, North Carolina 27611. The telephone number there is 919/733-3867. Questions about disasters, preparedness and related subjects for all parts of the state can be directed to this office.

This publication is concerned with the coastal zone of North Carolina and the following list gives the addresses and telephone numbers of local Civil Preparedness Agencies in the 20 coastal counties. Citizens should be able to obtain advice and specific information such as local evacuation plans from the county offices.

<u>County or City Agency</u>	<u>Telephone</u>
Beaufort County Civil Preparedness Agency P.O. Box 124 Washington, NC 27889	919/946-2046
Bertie County Civil Preparedness Agency P.O. Box 75 314 Belmont Street Windsor, NC 27983	919/794-3876
Brunswick County Civil Preparedness Agency Brunswick County Governmental Center Bolivia, NC 28422	919/253-4376
Camden County Civil Preparedness Agency Courthouse Camden, NC 27921	919/335-4077
Carteret County Civil Preparedness Agency P.O. Box 536, Courthouse Square Morehead City, NC 28557	919/728-2091
*Pine Knoll Shores Civil Preparedness Agency Town Hall, P.O. Box 757 Atlantic Beach, NC 28512	919/726-8021

*Pine Knoll Shores is located in Carteret County.

<u>County or City Agency</u>	<u>Telephone</u>
Chowan County Civil Preparedness Agency County Office Building Edenton, NC 27932	919/482-3111
Craven County Civil Preparedness Agency Drawer R 401 George Street New Bern, NC 28560	919/638-6135
Currituck County Civil Preparedness Agency Currituck, NC 27929	919/232-2836
Dare County Civil Preparedness Agency P.O. Box 156, Courthouse Manteo, NC 27954	919/473-3481
Gates County Civil Preparedness Agency Courthouse Gatesville, NC 27938	919/357-1240
Hertford County Civil Preparedness Agency P.O. Box 424, Courthouse Winton, NC 27986	919/358-1611
Hyde County Civil Preparedness Agency P.O. Box 87 Swanquarter, NC 27885	919/926-3451
New Hanover County Civil Preparedness Agency Box C-D, 115 Red Cross Street Wilmington, NC 28401	919/763-7555
Onslow (Jacksonville) County Civil Preparedness Agency 604 College Street Agriculture Building Jacksonville, NC 28540	919/347-4270
Pamlico County Civil Preparedness Agency County Courthouse Bayboro, NC 28515	919/745-3081
Pasquotank (Elizabeth City) County Civil Preparedness Agency 1404 Parkview Drive Elizabeth City, NC 27909	919/335-4444
Pender County Civil Preparedness Agency P.O. Box 28, Courthouse Burgaw, NC 28425	919/259-2629

<u>County or City Agency</u>	<u>Telephone</u>
Perquimans County Civil Preparedness Agency P.O. Box 2 Hertford, NC 27944	919/426-5564
Tyrrell County Civil Preparedness Agency P.O. Box 426 Columbia, NC 27925	919/796-5611
Washington County Civil Preparedness Agency P.O. Box 176 Roper, NC 27970	919/793-2771

Appendix II

DISASTER FACT SHEETS

The North Carolina Agricultural Extension Service has prepared a series of fact sheets to inform farmers and rural people about how to cope with natural disasters. They are available to the public at county Agricultural Extension Service offices or from the North Carolina Agricultural Extension Service, North Carolina State University, Raleigh, NC 27607. The titles of the Disaster Fact Sheets are:

Natural Disaster Assistance Available From The
U.S. Department of Agriculture
Disinfection Of Private Well Water Supplies After
A Natural Disaster
How To Settle An Insurance Claim
Hurricane And Flood Tips For Tobacco Farmers
Repairing Your House And Farm Buildings After The
Flood
How To Clean Your Freezer
Emergency Crop Flood Information
Reconditioning The Water System
Minimize Poultry Losses
After-The-Flood Tips for Homemakers
Care Of Storm-Damaged Trees And Shrubs
Care Of Household Utilities And Appliances
Income Tax Tips For Farm Operators
Tractor And Implement Cleaning
Guidelines For Restoring Fields Flooded By Salt
Water

Appendix III

DEFINITIONS OF TERMS ASSOCIATED WITH HURRICANES

Advisory. A formal message from a Weather Service Hurricane Warning Office giving warning information along with details on tropical cyclone location, intensity and movement and precautions that should be taken. The advisory may contain information on specific coastal warnings for which displays are made.

Bulletin. A public release from a Weather Service Hurricane Warning Office, issued at times other than those when advisories are required. The bulletin is similar in form to the advisory except that the bulletin includes additional general newsworthy information. The bulletin routinely will include a resume of all warnings in effect.

Cyclone. Any atmospheric system in which atmospheric pressure diminishes progressively to a minimum value at the center and toward which the winds blow spirally inward from all sides, resulting in a lifting of air and eventually in clouds and precipitation. Cyclones are the lows of weather maps. Circulation in a cyclone is counterclockwise in the Northern Hemisphere, clockwise in the Southern Hemisphere. The name does not suggest any degree of intensity and is applied to moderate as well as intense storms. Cyclones are divided into tropical and extratropical groups, depending upon characteristics of the surrounding air masses. The hurricane is a tropical cyclone, and is the most ideal vortex in the atmosphere.

Eye. (See Hurricane Center)

Gale Warning. A warning of sustained winds within the range 39 to 54 miles per hour (34 to 47 knots).

Storm Warning. (Associated with Tropical Cyclones.) A warning of sustained winds within the range of 55 to 73 miles per hour (48 to 63 knots) inclusive.

Hurricane. A warm core tropical cyclone in which maximum sustained surface wind is 74 miles per hour (64 knots) or greater.

Hurricane Center or Eye. The relatively calm area near the center of the storm. In this area winds are light and the sky often is only partly covered by clouds.

Hurricane "Season". The portion of the year having a relatively high incidence of hurricanes. In the Atlantic, Caribbean and Gulf of Mexico it is usually regarded as the period from June through November.

Hurricane Warning. A warning that one or both of the following dangerous effects of a hurricane are expected in a specified coastal area in 24 hours or less: (a) sustained winds 74 miles per hour (64 knots) or higher; (b) dangerously high water or a combination of dangerously high water and exceptionally high waves, even though winds expected may be less than hurricane force.

Hurricane Watch. An announcement for specific areas that a hurricane or an incipient hurricane condition poses a threat to coastal and inland communities. All people in the indicated areas should take stock of their preparedness requirements, keep abreast of the latest advisories and bulletins and be ready for quick action in case a warning is issued for their areas.

Local Statement. A public release prepared by a Weather Service Office in or near a threatened area giving specific details for its area of county responsibility on: (a) weather conditions; (b) sections that should be evacuated; (c) and other precautions necessary to protect life and property.

Squall. A sudden increase of wind speed by at least 18 miles per hour (16 knots) and rising to 25 miles per hour (22 knots) or more and lasting for at least one minute.

Tropical Cyclone. A non-frontal cyclone of synoptic scale, developing over tropical or sub-tropical waters and having a definite organized circulation.

Tropical Disturbance. A discrete system of apparently organized convection, generally 100 to 300 miles in diameter originating in the tropics or subtropics, having a non-frontal migratory character and having maintained its identity for 24 hours or more. It may or may not be associated with a detectable perturbation in the wind field. As such, it is the basic generic designation which, in successive stages of intensification, may be subsequently classified as a tropical wave, depression, storm or hurricane.

Tropical Wave. A trough or cyclonic curvature maximum in the trade wind easterlies. The wave may reach maximum amplitude in the lower middle troposphere, or may be the reflection of an upper troposphere cold low or equatorward extension of a middle latitude trough.

Tropical Depression. A tropical cyclone in which the maximum sustained surface wind is 38 miles per hour (33 knots) or less.

Tropical Storm. A warm core tropical cyclone in which the maximum sustained surface wind is in the range of 39 to 73 miles per hour (34-63 knots) inclusive.

Storm Tide. An abnormal rise of the sea along a shore primarily as the result of the winds of a storm. The storm tide may occur in basins not normally affected by the tide. It may also flood lowlands in coastal sections that are normally dry.

Sustained Wind. The wind obtained by averaging the observed value over a one-minute period.

APPENDIX IV

WIND EFFECTS OVER WATER

Knots	Descriptive	Sea Conditions	Wind force (Beaufort)	Probable wave height in ft.
0-1	Calm	Sea smooth and mirror-like.	0	-
1-3	Light air	Scale-like ripples without foam crests.	1	1/4
4-6	Light breeze	Small, short wavelets; crests have a glassy appearance and do not break.	2	1/2
7-10	Gentle breeze	Large wavelets; some crests begin to break; foam of glassy appearance. Occasional white foam crests.	3	2
11-16	Moderate	Small waves, becoming longer; fairly frequent white foam crests.	4	4
17-21	Fresh	Moderate waves, taking a more pronounced long form; many white foam crests; there may be some spray.	5	6
22-27	Strong	Large waves begin to form; white foam crests are more extensive everywhere; there may be some spray.	6	10
28-33	Near gale	Sea heaps up and white foam from breaking waves begins to be blown in streaks along the direction of the wind; spindrift begins.	7	14
34-40	Gale	Moderately high waves of greater length; edges of crests break into spindrift; foam is blown in well-marked streaks along the direction of the wind.	8	18

41-47	Strong gale	High waves; dense streaks of foam along the direction of the wind; crests of waves begin to topple, tumble, and roll over; spray may reduce visibility.	9	23
48-55	Storm	Very high waves with long overhanging crests. The resulting foam in great patches is blown in dense white streaks along the direction of the wind. On the whole, the surface of the sea is white in appearance. The tumbling of the sea becomes heavy and shocklike. Visibility is reduced.	10	29
56-63	Violent storm	Exceptionally high waves that may obscure small- and medium-sized ships. The sea is completely covered with long white patches of foam lying along the direction of the wind. Everywhere the edges of the wave crests are blown into froth. Visibility reduced.	11	37
64 and above	Hurricane	The air is filled with foam and spray. Sea completely white with driving spray; visibility very much reduced.	12	45

Appendix V

COASTAL HURRICANES OF THE 20TH CENTURY

The following list represents those tropical storms which were of full hurricane strength at the time they reached coastal North Carolina. The decayed stages of hurricanes reaching this area are not listed. Storms passing close enough off shore to affect land areas are included even though they did not make landfall.

1901 July 11: Made landfall near Oregon Inlet. No record of damage.

1903 September 15: Passed off shore but affected the northern Outer Banks.

1904 September 14: Made landfall between Charleston, South Carolina, and the North Carolina state line. Damage to crops in eastern and central North Carolina from wind and rain.

1904 November 13: Passed off shore near Cape Hatteras. Three wrecked schooners. Several persons drowned on land and at sea.

1906 September 17: Made landfall near Myrtle Beach, South Carolina. Property damage at Wrightsville Beach.

1908 July 30: Passed up the coast close to Cape Hatteras. Heavy rainfall caused flooding in the eastern counties. Considerable property damage at Wrightsville Beach.

1913 September 3: Made landfall between Hatteras and Beaufort. Storm surge in Pamlico Sound washed away railroad bridges at Washington and New Bern. Wind and rain caused severe damage to crops as far west as Durham.

1920 September 22: Made landfall between Wilmington and Morehead City. One person killed and many injured in Pitt County.

1924 August 25: Passed off shore just east of Hatteras. Two people drowned and Ocracoke partially flooded.

1930 September 12: Passed off shore causing minor wind damage from Atlantic Beach to Hatteras.

1933 August 22-23: Made landfall at Cape Hatteras. High tides and winds caused great damage in northeastern counties estimated at \$250,000.

1933 September 15-16: Made landfall west of Hatteras. Storm surge in Pamlico and Albemarle Sounds caused 21 deaths and \$3 million in damage. New Bern flooded.

1936 September 18: Passed up the coast slightly east of Hatteras. Estimated damage of \$55,000 to the northern coast. Heavy damage to crops.

1938 September 21: Passed off shore on its way north where it did considerable damage and was called "The Great New England Hurricane of 1938." No damage or loss of life reported in North Carolina.

1944 August 1: Made landfall near Southport. Heavy damage to structures at Carolina Beach. Considerable crop damage in the southern coastal counties. Estimated total damage was \$2 million.

1944 September 14: Passed a short distance east of Cape Hatteras moving northward. On the central and northern coastal areas 108 buildings were destroyed and more than 600 damaged. Estimated damage to crops at \$1 million. Heavy damage in Elizabeth City and Nags Head. One person killed.

1949 August 24: Passed off shore at Cape Hatteras directly over the Diamond Shoals Lightship. An estimated \$50,000 in property damage occurred, mostly in the vicinity of Buxton. Two persons died.

1953 August 13: Hurricane Barbara made landfall between Morehead City and Ocracoke. Estimated property damage was \$100,000 while the crop loss was \$1 million. One person died.

1954 August 30: Hurricane Carol passed just to the east of Cape Hatteras. Widespread light damage came to an estimated \$250,000.

1954 September 10: Hurricane Edna passed about 60 miles east of Cape Hatteras. Minor but widespread damage was estimated at \$75,000 for property and \$40,000 for crops.

1954 October 15: Hurricane Hazel made landfall right on the South Carolina line. From that point northward to Cape Lookout, the ocean front was ravaged by storm surge. At Long Beach 352 of the existing 357 buildings were totally destroyed. Nearby beaches suffered similar damage. Miles of grass covered dunes disappeared. Flooding occurred in Washington, New Bern and Elizabeth City. Heavy wind damage experienced all over eastern North Carolina

and record amounts of rainfall were recorded. Nineteen people, most of whom were in beach locations died. Total property damage amounted to approximately \$125 million.

1955 August 12: Hurricane Connie made landfall close to Cape Lookout. Caused severe flooding in low-lying coastal areas and around the sounds. Heavy beach erosion also occurred. No deaths were reported. Hurricane Diane followed in five days and made it impossible to assess the damage caused by this storm.

1955 August 17: Hurricane Diane made landfall near Carolina Beach and passed over Wilmington. Winds caused crop damage as far west as Raleigh. Heavy flooding occurred in Belhaven, Washington and New Bern. Crop damage in the eastern counties caused by this storm and Connie came to more than \$28 million much of it due to salt water flooding and rivers overflowing their banks. No deaths were reported.

1955 September 19: Hurricane Ione made landfall near Salter Path on Bogue Banks. In spite of high winds, damage from this source was minor. Heavy rains falling on already waterlogged soils were responsible for the most damage. Storm surge was responsible for the flooding of thousands of acres, and in New Bern 40 city blocks were inundated. Hundreds of homes were washed away. Seven people died. Estimated damage to crops and property was about \$88 million.

1958 September 27: Hurricane Helene passed off the coast from Wilmington to Cape Hatteras. Very high winds were responsible for damage to crops and structures estimated at \$11 million.

1960 September 11: Hurricane Donna made landfall between Wilmington and Morehead City and moved up the coast. Heavy damage was experienced by coastal communities from Wilmington to Nags Head. Beach erosion was considerable, and the corn crop in the coastal counties suffered severe wind damage. Eight people died, and damage was estimated at several millions of dollars.

1964 September 1: Hurricane Cleo passed from western North Carolina out to sea in the vicinity of Elizabeth City. Heavy rains caused flooding and damage to crops in the northeast.

1964 October 16: Hurricane Isbell made landfall near Morehead City and moved northward over the eastern counties. Caused some flash flooding and damage to the peanut crop.

1968 October 20: Hurricane Gladys moved up the coast and out to sea in the vicinity of Cape Hatteras. Damage was light and the state benefited from two days of moderate rainfall.

1971 September 30: Hurricane Ginger made landfall near Morehead City and began to dissipate as it moved inland. Tides were six feet or more above normal at Washington, Aurora, New Bern and Cherry Point. Thousands of acres of corn and soybeans in the eastern counties were affected. Damage was estimated at \$10 million.

1976 August 9: Hurricane Belle passed east of Cape Hatteras on its way north. Beaches were evacuated but only scattered minor damage occurred.

Appendix VI

SOME SEVERE 20TH CENTURY EXTRATROPICAL STORMS

The following list of noteworthy storms has been compiled because tropical storms are not the only significant weather disturbances experienced on the North Carolina coast. These non-tropical storms generally occur during the winter and spring months of the year. Since they are numerous and vary in strength and destructiveness, only major storms are included in this list. The compilation is based on a study of published records of the National Weather Service and its predecessor organizations from 1900 to the present. Information was obtained from various issues of the Monthly Bulletin, the Monthly Weather Review, Climatological Data of the U.S. by Sections, Climatological Data and Storm Data.

1902 December 4-5: An inland storm caused dangerous gales on the coast. Considerable waterfront damage occurred at Southport, Wilmington, Beaufort and Morehead City. Communications were interrupted because of damage to telephone and telegraph lines. Some wharves were blown or washed away, and several small vessels were wrecked.

1903 February 16: An inland storm caused gale winds throughout the state. Wilmington, New Bern and Washington experienced damage. Land between Pamlico Sound and the Atlantic Ocean was flooded. Seventeen persons died in the sinking of the passenger steamer "Olive" in the Chowan River.

1903 October 8-10: A severe storm formed off the North Carolina coast. Winds of 63 miles per hour were recorded at Hatteras.

1910 February 24-25: A northeast storm off the coast generated winds of 60 miles per hour at Hatteras.

1917 September 14-15: Heavy damage to property and crops was caused by a storm moving inland over the southern coast of North Carolina and then out to sea north of Hatteras. Roads and small bridges were washed out by a rainfall of four to eight inches.

1924 March 11: A storm moving northward along and near the coast generated winds of 66 miles per hour at Hatteras. These off shore winds caused unusually low water levels at New Bern and other places on western Pamlico Sound.

1932 March 6: An inland storm brought gale winds to the Atlantic and sound shores. Fishing nets, small boats, wharves, bridges, roads, buildings and telephone poles were damaged or destroyed. Dare County received more than half of the damage, and on the Outer Banks three new inlets were formed.

1932 November 28: More than \$50,000 in damage was caused on the south coast because of strong winds and high tide.

1933 January 25-29: Gale winds were reported at Hatteras. Coastal damage to roads and small craft reported.

1947 November 2-3: A northeast storm caused coastal damage as a result of the combination of strong winds and high tides. Morehead City and other coastal cities experienced flooding and several boats were grounded and destroyed.

1948 February 1: A northeast storm brought heavy snow to the eastern part of the state. Some coastal cities were practically isolated, and Wilmington reported more than \$1 million in damage. High tides and northeast winds caused damage along the coast.

1954 May 13: An inland storm which moved off the coast of North Carolina generated winds causing over \$100,000 damage to beaches. A 14,000-ton freighter was destroyed as a result of this storm near Cape Hatteras.

1956 January 8-12: Wind-driven water caused by a coastal storm resulted in \$50,000 property damage on the northern Outer Banks. Five cottages were destroyed in the area of Kitty Hawk. On Hatteras Island, a three-mile stretch of highway pavement was washed out.

1956 October 16-18, 27-30: These two northeast storms caused damage to beach highways, small craft and piers as a result of high tides. In the second storm three people were lost from fishing vessels.

1957 October 5-6: Winds reached 50 miles per hour along the northern coast during this off shore storm. High tides caused by prolonged easterly winds drove water over the Outer Banks highway and caused considerable beach erosion.

1958 October 19-23: A low pressure storm about 200 miles east of Cape Hatteras created wind gusts to 70 miles per hour from Cape Fear to the Virginia line. High tides affected beaches and cut the road from Oregon Inlet to Hatteras in several places. High water pushed into the Neuse River causing some flooding in New Bern.

1962 March 5-8: This gigantic "Northeaster" known as the Ash Wednesday Storm caused erosion on the coast from Hatteras northward greater than in any previously known storm. It opened an inlet 200 feet wide on Hatteras Island and destroyed miles of protective dunes. Miles of paved highways were either washed out or buried in sand. Beach homes by the hundreds were destroyed or damaged and hundreds of automobiles were either buried in sand or submerged in water. Waves more than 20 feet high on top of 10 foot tides were responsible for most of the damage. At Nags Head wind gusts near 70 miles per hour were recorded. Two people were known to have died as a result of the storm. Preliminary property damage estimates came to \$12 million.

1962 June 29: An off shore low pressure storm caused torrential rains in the central coastal counties. Amounts varied from four to 17 inches in 24 hours. Agricultural losses were high, particularly in the tobacco crop. High tides and winds were responsible for some beach erosion.

1962 November 25-December 5: A persistent low pressure storm off the coast caused very heavy beach erosion. Beaches were cut back as much as 50 feet in some places and sand dunes were damaged. Several buildings were destroyed and many damaged.

1964 February 12: An off shore low pressure storm generated rough seas which eroded the beach at Kill Devil Hills.

1964 May 3: The southeast coast was affected by a low pressure storm off shore. Gusts to 100 miles per hour were reported. Some wind damage occurred but beach erosion was slight.

1967 December 28: A coastal low pressure storm caused moderate damage from Wilmington to Morehead City. Wind gusts to 76 miles per hour were reported in Wilmington.

1968 May 26-27: A coastal low pressure storm caused heavy rain and strong winds in the northern coastal area. Widespread damage to boats and waterfront structures such as docks and piers was reported.

1969 November 1-2: A low pressure coastal storm moving northeastward was responsible for 60 mile per hour wind gusts. Moderate beach erosion occurred.

1970 December 31: On the southern coast some beach erosion and damage to piers was caused by a low pressure storm moving northward. Gales and high seas were reported.

1972 May 22-27: The northern coast was affected by a low pressure storm. Heavy beach erosion occurred and winds up to 50 miles per hour were recorded on shore.

1973 February 9-10: High winds and seas along the coast were caused by a low pressure storm off shore. Heavy beach erosion and property damage in various places resulted.

1973 March 22: A northeast storm blew up 10-12 foot seas. Highways were damaged along with some beach front property.

1976 February 1-2: A severe wind storm affected the northern coast particularly from Ocracoke through Manteo. Wind driven tides at the time covered two thirds of Hatteras Island. Portions of Manteo were flooded. Gusts of 70-90 miles per hour were reported at various Outer Banks locations.

Appendix VII

ATLANTIC HURRICANE NAMES

Starting in 1979 the names by which Atlantic hurricanes are designated will be both male and female. Previously they were all female. At the time of writing the list of new names had been submitted to the World Meteorological Organization for its expected final approval. As in the previous lists, names beginning with Q, U, X, Y and Z have been omitted because of their scarcity.

- 1979 -- Ana, Bob, Claudette, David, Elena, Frederic, Gloria, Henri, Isabel, Juan, Kate, Larry, Mindy, Nicolas, Odette, Peter, Rose, Sam, Teresa, Victor, Wanda
- 1980 -- Allen, Bonnie, Charley, Danielle, Earl, Frances, Georges, Hermine, Ivan, Jeanne, Karl, Lisa, Mitch, Nicole, Otto, Paula, Richard, Shary, Tomas, Virginia, Walter
- 1981 -- Arlene, Bret, Carla, Dennis, Emily, Floyd, Gert, Harvey, Irene, Jose, Katrina, Lenny, Maria, Nate, Ophelia, Philippe, Rita, Stan, Tammy, Vince, Wilma
- 1982 -- Alberto, Beryl, Chris, Debby, Ernesto, Florence, Gilbert, Helene, Isaac, Joan, Keith, Leslie, Michael, Nadine, Oscar, Patty, Rafael, Sandy, Tony, Valerie, William
- 1983 -- Alicia, Barry, Chantal, Dean, Erin, Felix, Gabrielle, Hugo, Iris, Jerry, Karen, Luis, Marilyn, Moel, Opal, Pablo, Roxanne, Sebastien, Tanya, Van, Wendy

References

- Anderson, L. O. and Walton R. Smith. Houses Can Resist Hurricanes, U.S. Forest Service Research Paper FPL 33. U.S. Department of Agriculture, August, 1965.
- Baker, Simon. The Citizen's Guide to North Carolina's Shifting Inlets, UNC-SG-77-08. UNC Sea Grant College Program, Raleigh, NC, 1977.
- Bosserman, Kenton and Robert Dolan. The Frequency and Magnitude of Extratropical Storms Along the Outer Banks of North Carolina, Technical Report 68-4. Coastal Research Associates, Charlottesville, VA, 1968.
- Carney, C. B. and A. V. Hardy. North Carolina Hurricanes. U.S. Department of Commerce, Environmental Science Services Administration, Washington, D.C., 1967.
- Collier, C. A. Construction Guidelines to Minimize Hurricane Damage to Shore Area Homes. Florida Department of Natural Resources, Tallahassee, 1976.
- Cooperman, A. I. and H. E. Rosendal. "Great Atlantic Coast Storm, 1962," Weather Bureau's Climatological Data, National Summary, Vol. 13, 1962.
- Cry, George W. Tropical Cyclones of the North Atlantic Ocean: Tracks and Frequencies of Hurricanes and Tropical Storms, 1871-1963, Technical Paper No. 55. U.S. Department of Commerce, Weather Bureau, Washington, D.C., 1965.
- DeAngelis, Richard M. "North Atlantic Tropical Cyclones, 1969," ESSA's Climatological Data, National Summary, Vol. 20, 1969.
- DeAngelis, Richard M. "North Atlantic Tropical Cyclones, 1972," NOAA's Climatological Data, National Summary, Vol. 23, 1972.
- Dunn, Gordon E. and Banner I. Miller. Atlantic Hurricanes. Louisiana State University Press, Baton Rouge, LA, 1960.
- FHA Pole House Construction. American Wood Preservers Institute, McLean, VA.
- Glossary of Meteorology. American Meteorological Society, Boston, MA, 1959.

- Hamlin, T. F. "When You Get Caught; Things That Will Help in Squall or Hurricane," Yachting, Vol. 98, October, 1955.
- Harris, D. L. Technical Paper No. 48, Characteristics of the Hurricane Storm Surge. U.S. Department of Commerce, Weather Bureau, Washington, D.C., 1963.
- Hill, E. L. et al. "Tornadoes Associated with Cyclones of Tropical Origin--Practical Features." Journal of Applied Meteorology, Vol. 5, December, 1966.
- How to Build Storm Resistant Structures. National Forest Products Association, Washington, D.C.
- Hurricane Information and Atlantic Tracking Chart. U.S. Department of Commerce, National Oceanic and Atmospheric Administration, Washington, D.C., 1971.
- Hurricane Safety Rules. U.S. Department of Commerce, National Oceanic and Atmospheric Administration, Washington, D.C., 1970.
- Hurricane, The Greatest Storm on Earth. U.S. Department of Commerce, National Oceanic and Atmospheric Administration, Washington, D.C., 1971.
- Information For Buyers and Owners of Coastal Property in North Carolina. Center for Marine and Coastal Studies and UNC Sea Grant College Program, N.C. State University, Raleigh, NC.
- MacNab, Cynthia, Editor. Disaster Handbook for Extension Agents. Cooperative Extension Service, The Pennsylvania State University, University Park, PA.
- Ogg, R. D. Anchors and Anchoring. Danforth Division of the Eastern Company, Portland, ME, 1977.
- Pilkey, Jr., Orrin H. et al. How to Live With an Island: A Handbook to Bogue Banks, North Carolina. North Carolina Department of Natural and Economic Resources, Raleigh, NC, 1975.
- Protecting Mobile Homes From High Winds, TR-75. Department of Defense, Defense Civil Preparedness Agency, Washington, D.C., February, 1974.
- Riggs, Stanley R. "Barrier Islands--Natural Storm Dependent Systems" published in Barrier Islands and Beaches. Technical Proceedings of the 1976 Barrier Island Workshop, Annapolis, MD, May, 1976.

Simpson, R. H. and M. B. Lawrence. NOAA Technical Memorandum NWS SR-58, Atlantic Hurricane Frequencies Along the U.S. Coastline. U.S. Department of Commerce, National Oceanic and Atmospheric Administration, National Weather Service, Fort Worth, TX, June, 1971.

Smith, Walton R. "Wood Against the March Northeaster," Forest Products Journal, Vol. 12, 1962.

Some Devastating North Atlantic Hurricanes of the 20th Century. U.S. Department of Commerce, National Oceanic and Atmospheric Administration, Washington, D.C., 1974.

State of North Carolina Long-Range Hurricane Rehabilitation Project. North Carolina Council of Civil Defense, Raleigh, NC, December, 1955.

Survival in a Hurricane. U.S. Department of Commerce, National Oceanic and Atmospheric Administration, Washington, D.C., 1970.

Tannehill, I. R. The Hurricane. U.S. Department of Commerce, Weather Bureau, Washington, D.C., 1956.

The Homeport Story: An Imaginary City Gets Ready for a Hurricane. U.S. Department of Commerce, National Oceanic and Atmospheric Administration, National Weather Service, Washington, D.C., 1971.

Walton, Jr., Todd L. Hurricane-Resistant Construction for Homes, SUSF-SG-76-005. Florida Sea Grant Program, Gainesville, FL.

Zornig, H. F. and G. E. Sherwood. Wood Structures Survive Hurricane Camille's Winds, U.S. Forest Service Research Paper FPL 123. U.S. Department of Agriculture, October, 1969.

Illustration Credits

- Cover - Hurricane Belle, August 9, 1976.
National Environment Satellite Service,
National Oceanic and Atmospheric
Administration.
- Figure 1 - Simon Baker, UNC Sea Grant College
Program.
- Figure 2 - Forest Products Laboratory, Forest
Service, US Department of Agriculture.
- Figures 3-6 - Simon Baker, UNC Sea Grant College
Program.
- Figures 7-9 - National Oceanic and Atmospheric
Administration.
- Figures 10-11 - US Army Engineer District, Wilmington,
North Carolina.
- Figure 12 - State of North Carolina, Long-Range
Hurricane Rehabilitation Project.
- Figure 13 - National Environmental Satellite Service,
National Oceanic and Atmospheric
Administration.
- Figures 14-15 - Agricultural Extension Service, North
Carolina State University.
- Figure 16 - North Carolina Department of Transporta-
tion, aerial photograph M 1058, No. 15.
- Figure 17 - US Department of Commerce, Weather
Bureau's Climatological Data, National
Summary, Vol. 13, 1962.
- Figures 18-19 - Forest Products Laboratory, Forest Service,
US Department of Agriculture.
- Figure 20 - Defense Civil Preparedness Agency, Depart-
ment of Defense, Protecting Mobile Homes
From High Winds.

Acknowledgments

Information and assistance rendered by a number of people and organizations proved to be invaluable in the preparation of this publication. Both the National Hurricane Center, Miami, Florida, and the Environmental Data Service, National Climatic Center, Asheville, North Carolina, were very helpful in responding to requests for published materials.

Thanks go to the following people who provided a variety of information utilized in the preparation of this publication: Kenneth M. Edwards, BM2, US Coast Guard; Chester Gray, N.C. Department of Transportation; William Harris, N.C. Division of Civil Preparedness; John R. McClain, National Weather Service; and Spencer M. Rogers, UNC Sea Grant College Program.

A special debt of gratitude is owed to Dr. Gerald F. Watson, Department of Geosciences of North Carolina State University for his comments on the final draft of the publication. Other helpful comments were contributed by John Clark and Donald Rynders of the National Weather Service at Raleigh-Durham Airport.

Finally, thanks are due to Daphne Webster who served as a research assistant in the initial part of this project and to Patricia Van Hoy, Carolyn Sue Holleman and Elaine J. Murray who typed the manuscript.

NATIONAL SEA Grant
FEB 21 1979