



# NOAA Fisheries WCR Anadromous Salmonid Design Manual - NMFS 2022



**NOAA**  
**FISHERIES**

# **NOAA Fisheries West Coast Region Anadromous Salmonid Passage Design Manual**

Authors

National Marine Fisheries Service  
West Coast Region  
Environmental Service Branches

**U.S. DEPARTMENT OF COMMERCE**  
**National Oceanic and Atmospheric Administration**  
National Marine Fisheries Service

For questions or to provide comments please contact the following:

For Washington, Oregon, and Idaho:

NOAA Fisheries West Coast Region  
Environmental Services Branch  
1201 Northeast Lloyd Boulevard, Suite 1100  
Portland, Oregon 97232  
503-230-5400

For California:

NOAA Fisheries West Coast Region  
Environmental Services Branch  
777 Sonoma Avenue, Room 325  
Santa Rosa, California 95404

707-387-0737

Web address:

<http://www.westcoast.fisheries.noaa.gov/>

Suggested citation:

NMFS (National Marine Fisheries Service). 2022. NOAA Fisheries West Coast Region  
Anadromous Salmonid Passage Design Manual, NMFS, WCR, Portland, Oregon

# Table of Contents

1	Introduction .....	15
1.1	Statutory Background .....	18
1.2	Biological Background .....	19
1.3	Migration Barriers.....	20
1.4	Design Process .....	21
1.5	Experimental Technologies.....	22
1.6	Temporary and Interim Passage.....	22
1.7	Section 7 Consultation under the Endangered Species Act .....	23
1.8	Additional Information .....	23
2	Definition of Terms .....	24
3	Design Development.....	33
3.1	Introduction.....	33
3.2	Design Process .....	33
3.2.1	Preliminary Design .....	34
3.2.2	Detailed or Final Design .....	34
3.2.3	Smaller Projects .....	35
3.2.4	Review Timelines .....	35
3.3	Information Requirements .....	35
3.3.1	Functional Requirements .....	35
3.3.2	Site and Physical Information.....	35
3.3.3	Biological Information.....	37
3.3.4	Operations and Maintenance Information.....	38
4	Design Flow Range .....	40
4.1	Introduction.....	40
4.2	Design Low Flow for Fish Passage.....	40
4.3	Design High Flow for Fish Passage.....	40
4.4	Fish Passage Design for Flood Flows .....	41
5	Upstream Adult Fish Passage Systems .....	42
5.1	Introduction.....	42



5.1.1	Passage Alternatives: Volitional and Non-volitional.....	45
5.1.2	Passage of Other Species .....	45
5.1.3	Temperature Considerations .....	46
5.2	Fishway Entrance.....	46
5.2.1	Description and Purpose .....	46
5.2.2	Specific Criteria and Guidelines – Fishway Entrance.....	46
5.3	Auxiliary Water Systems .....	52
5.3.1	Description and Purpose .....	52
5.3.2	Specific Criteria and Guidelines – AWS Fine Trash Racks.....	53
5.3.3	Specific Criteria and Guidelines – AWS Screens .....	54
5.3.4	Specific Criteria and Guidelines – AWS Flow Control .....	54
5.3.5	Specific Criteria and Guidelines – AWS Excess Energy Dissipation.....	54
5.3.6	Specific Criteria and Guidelines – AWS Diffusers.....	56
5.3.7	Specific Criteria and Guidelines – Bedload Removal Devices.....	57
5.4	Transport Channels .....	57
5.4.1	Description and Purpose .....	57
5.4.2	Specific Criteria and Guidelines – Transport Channels.....	58
5.5	Fish Ladder Design .....	59
5.5.1	Description and Purpose .....	59
5.5.2	Common Types of Fish Ladders.....	59
5.5.3	Specific Criteria and Guidelines – Fish Ladder Design.....	68
5.6	Counting Stations and Windows.....	71
5.6.1	Description and Purpose .....	71
5.6.2	Specific Criteria and Guidelines – Counting Stations.....	72
5.6.3	Specific Criteria and Guidelines – Counting Windows .....	72
5.7	Fishway Exit Control .....	73
5.7.1	Description and Purpose .....	73
5.7.2	Specific Criteria and Guidelines – Fishway Exit Control.....	74
5.8	Fishway Exit Sediment and Debris Management .....	75
5.8.1	Description and Purpose .....	75
5.8.2	Specific Criteria and Guidelines – Coarse Trash Rack .....	75
5.8.3	Specific Criteria and Guidelines – Debris and Sediment.....	76
5.9	Roughened (Baffled) Chute Fishways .....	77
5.9.1	Description and Purpose .....	77
5.9.2	Specific Criteria and Guidelines – Baffled Chutes .....	77

5.10	Nature-Like Fishways .....	82
5.10.1	Experimental Applications.....	83
5.10.2	Design Methods .....	83
5.10.3	Specific Criteria and Guidelines .....	84
5.10.4	Monitoring and Maintenance .....	86
5.11	Miscellaneous Considerations.....	87
5.11.1	Security .....	87
5.11.2	Access .....	87
5.11.3	Edge and Surface Finishes .....	87
5.11.4	Protrusions .....	87
5.11.5	Exposed Control Gates.....	87
5.11.6	Maintenance Activities .....	87
5.12	Operations and Maintenance Considerations.....	88
5.12.1	Activity Near the Ladder.....	88
5.12.2	Maximum Outage Period .....	88
6	Exclusion Barriers .....	89
6.1	Introduction.....	89
6.1.1	Fish Safety .....	89
6.1.2	Barriers Used to Collect Information.....	90
6.1.3	Other Species .....	90
6.1.4	Flow Range .....	90
6.2	Types of Exclusion Barriers.....	90
6.3	Picket and Weir Barriers .....	93
6.3.1	Risk of Fish Impingement.....	94
6.3.2	Debris.....	94
6.3.3	Picket Barriers and Fixed Bar Racks .....	94
6.3.4	Diffusers.....	96
6.3.5	Horizontal Outlet Diffusers.....	98
6.3.6	Fish Weirs .....	100
6.4	Drop Structure Barriers .....	104
6.4.1	Orientation of Drop Structure Barriers .....	104
6.4.2	Upstream Impacts .....	104
6.4.3	Combination Velocity and Vertical Drop Barriers .....	104
6.4.4	Vertical Drop Barriers.....	106
6.4.5	Velocity Barriers .....	107

6.5	Behavioral Barriers .....	108
7	Adult Fish Trapping Systems .....	109
7.1	Introduction.....	109
7.2	Types of Traps .....	110
7.2.1	General Criteria.....	111
7.3	Design Scoping .....	111
7.3.1	Purpose.....	111
7.4	Fish Handling Criteria.....	112
7.4.1	Nets .....	112
7.4.2	Anesthetization.....	112
7.4.3	Non-Target Fish .....	113
7.4.4	Frequency.....	113
7.4.5	Personnel.....	113
7.5	Trap Design Criteria.....	113
7.5.1	Trap Components.....	113
7.5.2	General.....	114
7.5.3	Pickets .....	114
7.5.4	Trapping Mechanisms.....	115
7.5.5	Holding Pools.....	117
7.5.6	Crowders .....	120
7.5.7	Brails .....	121
7.5.8	False Weirs.....	123
7.5.9	Distribution Flumes and Pipes .....	125
7.5.10	Anesthetic Recovery Pools .....	126
7.6	Lifting Devices.....	127
7.6.1	Fish Lifts and Hopper Passage Systems.....	127
7.6.2	Fish Lock .....	128
7.7	Single Holding Pool Traps.....	129
7.8	Upstream Transportation Criteria .....	130
7.8.1	Maximum Transport Tank Loading Densities and Time.....	130
7.8.2	Transport Tanks .....	130
7.8.3	Release Location.....	131
8	Fish Screen and Bypass Facilities .....	133
8.1	Introduction.....	133
8.1.1	100% Flow Screening .....	133

8.1.2	Deviation from These Criteria .....	133
8.1.3	Experimental Technology .....	134
8.2	Existing Fish Screens .....	134
8.2.1	General .....	134
8.3	Project Design Review .....	135
8.4	Structure Placement .....	135
8.4.1	In-Stream Installations .....	135
8.4.2	In-Canal Installations .....	137
8.4.3	Lakes, Reservoirs, and Tidal Areas.....	139
8.5	Screen Design Specifications.....	140
8.5.1	Approach Velocity .....	140
8.5.2	Effective Screen Area .....	140
8.5.3	Sweeping Velocity .....	141
8.5.4	Flow Distribution .....	142
8.5.5	Active Screen Cleaning Systems (Active Screens).....	143
8.5.6	Passive Screens .....	145
8.5.7	Screen Submergence and Clearance .....	145
8.5.8	Screen Material .....	149
8.5.9	Civil Works and Structural Features.....	150
8.6	Bypass Systems.....	151
8.6.1	Bypass Design.....	151
8.6.2	Bypass Entrance.....	152
8.6.3	Bypass Conduit and System Design .....	154
8.6.4	Bypass Outfalls .....	157
8.7	Water Drafting .....	158
8.7.1	Water Drafting Operating Guidelines .....	158
8.7.2	Fish Screens for Water Drafting .....	158
8.8	Special Case: Horizontal Screens .....	159
8.8.1	NMFS Engineer Involvement .....	160
8.8.2	Design Process .....	160
8.8.3	General Criteria.....	160
8.8.4	Specific Criteria .....	160
8.9	Special Case: Conical Screens .....	163
8.9.1	Locations.....	164
8.9.2	Approach Velocity .....	164

8.9.3	Flow Uniformity .....	164
8.9.4	Effective Screen Area .....	164
8.9.5	Submergence.....	165
8.10	Project Inspections and Evaluations .....	165
8.10.1	General.....	165
8.10.2	Quality Assurance and Quality Control.....	165
8.10.3	Inspection.....	166
8.11	Operations and Maintenance Plans .....	169
8.11.1	General.....	169
8.11.2	Operations .....	169
8.11.3	Maintenance.....	169
8.11.4	Maintenance Records.....	170
8.11.5	Periodic Visual Inspections.....	170
9	Operations and Maintenance .....	172
9.1	Introduction.....	172
9.2	General Criteria.....	172
9.3	Specific Criteria – Staff Gages.....	172
9.4	The Operations and Maintenance Plan .....	173
9.4.1	O&M Plan Development and Approval.....	173
9.4.2	Group O&M Plans .....	173
9.4.3	General.....	173
9.4.4	Posting the O&M Plan .....	174
9.4.5	Periodic Review of O&M Plans by NMFS.....	174
10	References .....	175

## **Table of Appendices**

Appendix A	Near-Field Hydraulics that Affect Salmonid Passage in Tide Gates
Appendix B	Infiltration Galleries
Appendix C	Experimental Technologies
Appendix D	Surface Collection
Appendix E	Performing Hydraulic Evaluations
Appendix F	Juvenile Fish Collection and Evaluation Facilities
Appendix G	Columbia and Snake River Fish Passage Facilities
Appendix H	Sizing Fish Ladder Pools Based on Energy Dissipation and Fish Run Size
Appendix I	Upstream Juvenile Fish Passage



## Table of Figures

Figure 1-1. West Coast Region Fish Passage Guideline Flow Chart.....	16
Figure 5-1. Components of vertical slot fishway for upstream passage .....	44
Figure 5-2. Schematic of a fishway AWS diffuser system in plan (a) and section (b) views.....	55
Figure 5-3. Plan view of a vertical slot ladder showing generalized flow paths.....	60
Figure 5-4. Oblique view of a vertical slot ladder baffle when dewatered .....	61
Figure 5-5. Dimensions of a typical vertical slot ladder pool .....	61
Figure 5-6. Examples of pool and weir ladders .....	63
Figure 5-7. Ice Harbor-style weir and orifice ladder (adapted from Gauley et al. 1966.....	64
Figure 5-8. Overhead views of Ice Harbor-style weir and orifice fish ladders.....	65
Figure 5-9. Pool and chute ladder dewatered (at left) and watered (at right) .....	67
Figure 5-10. Half ladder designs for projects with reduced available fishway flows.....	68
Figure 5-11. Sloping coarse trash rack on a fishway exit channel.....	76
Figure 5-12. Drawings, dimensions, and a photo of a Denil fishway .....	78
Figure 5-13. Examples of ASP fishways .....	79
Figure 5-14. Plan and elevation views of a typical ASP fishway .....	81
Figure 6-1. Classifications of exclusion barriers .....	91
Figure 6-2. Fish weir constructed with pickets in plan (a) and section (b) views.....	91
Figure 6-3. Picket barrier panels under construction at the Slide Creek tailrace barrier located on the North Umpqua River, Oregon.....	93
Figure 6-4. Layout of a horizontal outlet diffuser covering the entrance to a turbine draft tube.....	99
Figure 6-5. Cross sections of rigid and floating picket weirs .....	101
Figure 6-6. Elk Creek Dam picket weir (Elk Creek, Oregon).....	102
Figure 6-7. Cross section of a combination velocity and vertical drop barrier.....	105
Figure 6-8. Cross section of a vertical drop barrier .....	107
Figure 6-9. Cross section of a velocity barrier.....	108
Figure 7-1. Finger weir schematic .....	116
Figure 7-2. Cutaway of a Vee trap.....	116
Figure 7-3. Cross section of a false weir.....	123
Figure 8-1. Aerial view of the Garden City-Lowden 2 water diversion on Walla Walla River near Touchet, Washington (Notes: River flow is from left to right. The bankline screen is located at the head end of the canal, just upstream of the spillway and adult ladder exit.).....	136
Figure 8-2 Bankline screens at the Garden City-Lowden 2 diversion on the Walla Walla River near Touchet, Washington, under construction .....	137

Figure 8-3 Bankline vertical flat plate fish screen sized for 3,000 ft <sup>3</sup> /s (Glenn-Colusa Irrigation District) along the Sacramento River in California (Note: the screen is shown in operation (left) and during construction (right).) .....	137
Figure 8-4 Schematic of a typical in-canal fish screen system layout and components at water diversions .....	138
Figure 8-5 Vertical plate screen facility under construction in a diversion canal located on the Santiam River near Stayton, Oregon.....	139
Figure 8-6 Schematic diagram of sliding, overlapping porosity plates used to control porosity and achieve uniform flow conditions through fish screens.....	143
Figure 8-7 Large-sized rotary drum screen at the Sunnyside Canal located on the Yakima River near Yakima, Washington.....	147
Figure 8-8 Medium-sized rotary drum screen at the Burlingame Diversion located on the Walla Walla River near Walla Walla, Washington .....	147
Figure 8-9 Rotary drum screens installed in a water diversion canal and operated (i.e., powered) by paddle wheels .....	148
Figure 8-10 Typical end-of-pipe screen equipped with “wagon wheels” to elevate the screen off the stream bottom.....	149
Figure 8-11 Conical screen .....	163
Figure 8-12 Elevation view of a conical fish screen showing the effective depth.....	165

## List of Tables

Table 5-1. Dimensions for vertical slot ladder components measured in feet. ....	62
Table 5-2. Dimensions for Ice Harbor fishways measured in feet.....	65
Table 7-1. Holding Pool capacity when water temperature exceeds 50°F.....	118

# Acknowledgments

These engineering guidelines were developed through decades of work conducted by past and present NMFS fish passage engineers and biologists who laid much of the foundation for this document. We are grateful for their hard work and dedication. We also thank the numerous tribal, agency, and utility researchers; biologists; and engineers who contributed to an improved understanding of how juvenile and adult salmonids behave when approaching and passing structures. The state of knowledge on fish passage engineering has improved substantially over the course of developing these guidelines and will continue to do so over time as new engineering designs, evaluation techniques, and methods are developed and tested. We are also grateful to our reviewers who took the time to provide thoughtful and constructive comments to assist in updating these guidelines.

# Acronyms and Abbreviations

Symbol or Acronym	Term or Title
°C	degrees Celsius
°F	degrees Fahrenheit
ASP	Alaska steep pass
AWS	auxiliary water system or auxiliary water supply system
BOR	U.S. Bureau of Reclamation
ft <sup>3</sup> /s	cubic feet per second
EDF	energy dissipation factor
ESA	Endangered Species Act
FERC	Federal Energy Regulatory Commission
FERL	Fisheries-Engineering Research Laboratory
FPA	Federal Power Act
ft <sup>2</sup>	square foot
ft <sup>3</sup>	cubic foot
ft/s	foot per second
ft-lb/ft <sup>3</sup> /s	foot pounds per cubic foot of flow per second
GCF	grade control fishway
gpm	gallon per minute
HDM	Hydraulic Design Method
HGMP	Hatchery and Genetic Management Plan
lb	pound
LSSS	Low Slope Stream Simulation
MSA	Magnuson-Stevens Fishery Conservation and Management Act
mm	millimeter
NMFS	National Marine Fisheries Service

Symbol or Acronym	Term or Title
NOAA	National Oceanic and Atmospheric Administration
O&M	operations and maintenance
PIT	passive integrated transponder
R/D	ratio of radius of curvature to pipe diameter
SSD	Stream Simulation Design
USACE	U.S. Army Corps of Engineers
VFD	variable frequency drive
WCR	West Coast Region



# 1 Introduction

The Environmental Service Branches provide technical and engineering assistance to National Oceanic and Atmospheric Administration's National Marine Fisheries Service (NMFS) West Coast Region (WCR) fisheries biologists. NMFS also plays a supportive and advisory role in the management of living marine resources in the areas under state jurisdiction. This document is intended to assist with improving conditions for salmonids that must migrate past barriers to complete their life cycle. Effective fish passage requires the integration of numerous scientific and engineering disciplines including, but not limited to, fish behavior, ichthyomechanics, hydraulics, hydrology, fluvial geomorphology and engineering. Installing a fish passage structure does not constitute providing satisfactory fish passage unless all of the above components are adequately factored into the design.

This document is intended to: provide internal assistance to NMFS biologists in designing effective fish passage; encourage consistency across the WCR region; while supporting the implementation of NMFS's statutory authorities related to the conservation and protection of marine resources; and provide technical assistance to project proponents.

The efficacy of any fish passage structure, device, facility, operation, or measure is highly dependent on local hydrology, target species and life stage, obstacle orientation relative to the stream, facility operation, and many other site-specific considerations. While the information provided herein will apply to many structures, it should be regarded as general guidance for the design, operation, and maintenance of fishways throughout the WCR. The criteria described in this document are not universally applicable and should not replace site-specific recommendations.

This document provides general guidance and is not intended as an alternative to active consultation with NMFS biologists and engineers. Application of these criteria in the absence of consultation does not imply approval by NMFS. This document provides criteria and additional guidelines for the design and operation of facilities at barriers to fish migration and water intakes in California, Washington, Oregon, and Idaho. The facilities are designed to create safe passage routes for adult and juvenile salmonids in rivers and streams and through reservoirs, restore habitat connectivity within watersheds, and enhance salmonid population productivity. NMFS's manual for fish passage facility design is meant to help NMFS staff advise project applicants on the engineering design of future fish passage projects and modifications to existing projects. The criteria are based on decades of experience developing, testing, operating fish passage systems and relies on the best available scientific information.

The WCR has developed a flow chart for how to use their various fish passage guidance documents (Figure 1). Prior to designing a fish passage facility, NMFS recommends the project proponent familiarize themselves with the "NOAA Fisheries WCR Guidance to Improve the Resilience of Fish Passage Facilities to Climate Change" (Improving Resilience) guidance

document. The Improving Resilience document outlines how to incorporate projected future flows the facility may experience over the life of the project and should be the starting point for the design process.

### National Oceanic and Atmospheric Administration (NOAA) West Coast Region (WCR) Guidelines Document Flow Chart

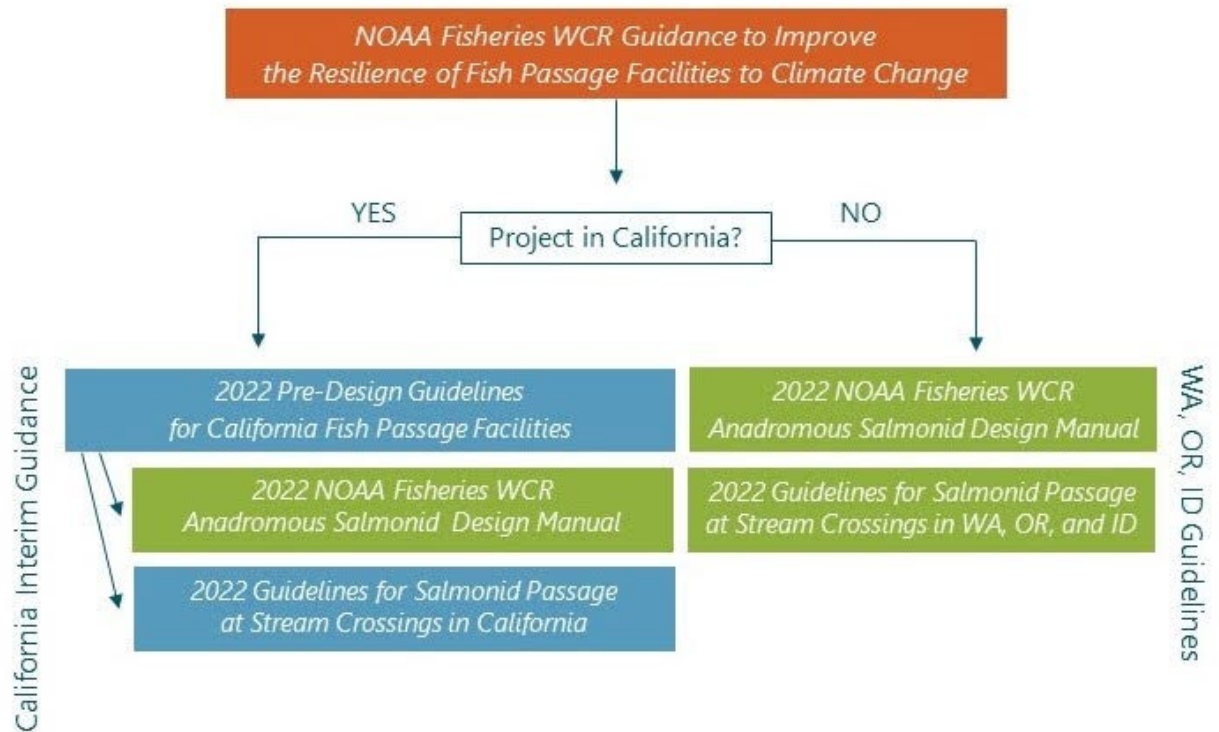

**Figure 1-1. West Coast Region Fish Passage Guideline Flow Chart**

In 2013, the Northwest and Southwest regions of the National Oceanic and Atmospheric Administration’s (NOAA) NMFS were merged to form the WCR. This document is the first step in integrating fish passage design criteria and guidelines of the two former regions. This document, *NOAA Fisheries West Coast Region Anadromous Salmonid Passage Design Guidelines* supersedes the following documents:

- Northwest Region’s *Anadromous Salmonid Passage Facility Design*, dated July 2011
- Southwest Region’s *Fish Screening Criteria for Anadromous Salmonids*, dated January 1997
- Southwest Region’s Experimental Fish Guidance Position Statement, dated January 1994
- Southwest Region’s Water Drafting Specifications, dated August 2001

This document provides criteria and guidance for passage of anadromous salmonids only. For additional passage guidance concerning non-salmonids, refer to applicable state and federal entities.

This document contains introductory chapters, technical chapters, and appendices. The introductory chapters (Chapters 1 and 2) provide the statutory and biological background for the requirement to provide safe, timely, and effective passage of salmonids around barriers and definitions of key terms. The technical chapters (Chapters 3 through 10) present design criteria and guidelines that result in hydraulic conditions salmonid fish require to successfully pass barriers and minimize effects to salmonid populations, along with the scientific basis for criteria for which applicable references are available. The appendices provide information on aspects of fish passage facility design that are under development and may change over time after additional testing. Additionally, the appendices contain background information that was removed from the technical chapters to make the chapters more streamlined, but still needs to be available to the reader because the information is informative and relevant.

Throughout the chapters all criteria are italicized to be easily identifiable. In addition, chapter and appendix sections are cross-referenced where applicable. For example, the chapter on screens may direct the reader to the chapter on design flows so a reader interested in screens will understand that additional information is available in another chapter.

NMFS has separated these fish passage engineering guidelines into two volumes. This first volume entitled *NOAA Fisheries West Coast Region Anadromous Salmonid Passage Design Manual* provides design guidance for structural fish passage, protection, and exclusion projects not associated with river or stream crossings. This first volume represents guidelines that are based on decades of research, monitoring, and NMFS' experience with these types of passage systems. NMFS considers material in this volume to be in a mature state and does not anticipate it will change significantly over time.

The guidance in Chapter 4 of this volume applies to projects located in Washington, Oregon, and Idaho over the range of anadromous salmonid habitat in those states. Due to significantly different hydrologic conditions in California and those conditions impact on life history of NMFS trust species, project proponents should work with NMFS engineering staff to determine the appropriate design flows following the 2022 Pre-Design Guidelines for California Fish Passage Facilities.

The second volume, entitled *Guidelines for Salmonid Passage at Stream Crossings in Oregon, Washington, and Idaho* (NMFS 2022b) represents a growing body of work relating to fish passage at stream crossings that NMFS expects will expand significantly in the future. Separating these guidelines into two volumes will allow NMFS to refine and expand this additional volume in the near future as new information becomes available, without having to reopen and modify the entire guidelines document. NMFS 2022b includes introduction matter as well as two technical chapters relating to stream crossings and grade control fishways.

The guidance in Chapters 3 and 4 of NMFS 2022b applies to projects located in Washington, Oregon, and Idaho over the range of anadromous salmonid habitat. Given significantly different hydrologic conditions, stream crossing projects in California should refer

to: *Guidelines for Salmonid Passage at Stream Crossings in California* (NMFS 2019, addendum).

These criteria and guidelines were developed based on 60 years of agency experience in creating successful fish facility designs and have been further refined through a collaborative process with regional fish facility design experts. The criteria and guidelines in Volume 2 address more emerging fields of fish passage engineering and stream restoration. The criteria and rationale provided will be revised as needed if new information suggests that updated criteria would further improve passage conditions for fish.

## 1.1 Statutory Background

NMFS is mandated by U.S. Congress to manage, conserve, and protect living marine resources within the U.S. Exclusive Economic Zone. NMFS is authorized to conduct these actions under the Federal Power Act (FPA; administered by the Federal Energy Regulatory Commission [FERC]), the Fish and Wildlife Coordination Act (administered by the U.S. Fish and Wildlife Service), the Endangered Species Act (ESA), and the Magnuson-Stevens Fishery Conservation and Management Act (MSA). This document provides criteria and technical assistance to project proponents on the design of fish passage facilities in order to provide safe, timely, and effective fish passage, consistent with NMFS responsibilities under the ESA, FPA, and MSA.

The requirement of safe, timely and effective passage derives from the unofficial but reliable definition of a fishway presented by Congress in a report related to the Energy Policy Act of 1992. The definition of "safe and timely passage" was expanded to include both passage structures and operations "necessary to ensure the effectiveness" of such structures. None of the terms "safe," "timely," or "effective" are further defined. However, in practice NMFS typically includes provisions which give these terms meaning. Regarding "safe" passage, NMFS requires licensees to design and operate their fishways so that they minimize the occurrence of injury or mortality experienced by fish while attempting to utilize the fishway. Regarding "timely" passage, a fishway prescription may include provisions for reducing the time in which a fish utilizing the fishway is subjected to stressful interactions, such as time spent in a trap or in transit, or a requirement for flows which will attract fish to a passage facility. Regarding "effective" passage, NMFS typically includes provisions requiring the operator to ensure that its facility succeeds in passing as close to 100% of the fish attempting to migrate through the system as possible.

Following these criteria will likely streamline processes, improve certainty, and improve the likelihood of success. NMFS also provides support and advice to states regarding the management of living marine resources in areas under state jurisdiction. This includes salmon (*Oncorhynchus spp.*) and steelhead (*O. mykiss*) due to their economic, cultural, recreational, and symbolic importance to society (NRC 1996).

NMFS pursues fish passage to contribute to its fishery management and ESA recovery goals. In reviewing, planning, designing, and implementing fish passage facilities, NMFS engineers will coordinate with NMFS biologists to make sure the particular target species, population numbers, migration timing and recovery goals are met.

## 1.2 Biological Background

Fish species within the family Salmonidae spawn in fresh water. Some species spend their entire lives in fresh water. Others spend a portion of their lives in marine waters where they grow and become sexually mature before returning to fresh water to spawn (Quinn 2005). The life history pattern that involves marine residence is known as anadromy, and salmonid species that display this pattern are referred to as anadromous salmonids.

NMFS has identified several key parameters that are used to judge the overall status and viability of salmon and steelhead populations. These include abundance, genetic diversity and life history diversity, productivity, and spatial structure (McElhany et al. 2000). NMFS considers a population to be viable if over a 100-year timeframe it can withstand threats and the risk of extinction from demographic variation, local environmental variation, and genetic diversity changes (McElhany et al. 2000). For examples of how these population parameters are used in viability assessments and recovery planning, see Lindley et al. (2007) and NMFS (2014). NMFS assesses any effects of barriers to migration and water intake structures on anadromous salmonids in the context of these parameters and overall population viability. The viability parameters are briefly described as follows:

Abundance. This is a commonly used species conservation and management parameter that refers to the number of organisms in a population.

Genetic diversity and life history diversity. Diversity refers to the distribution of traits within and among populations, which range in scale from DNA sequence variation at single genes to complex life history traits (McElhany et al. 2000). Genetic diversity and life history diversity are interrelated; thus, this parameter is not as straightforward as abundance. For example, a unique characteristic of anadromous salmonids is their high degree of fidelity to natal streams or rivers (Quinn 2005), which is a genotypic trait. This trait in turn facilitates local adaptations that result in phenotypic expressions of highly variable life history patterns (Taylor 1991; Waples 1991).

Life history diversity is often cited as a crucial component of salmonid population resiliency. This is based on evidence that maintaining multiple and diverse salmon stocks that fluctuate independently of each other reduces extinction risk and long-term variation in regional abundances (Roff 1992; Hanski 1998; Hilborn et al. 2003). Schindler et al. (2010) describe this as the portfolio effect, where risk is spread across multiple stocks. Preserving and restoring life history diversity is an integral goal of many salmonid conservation programs (Ruckelshaus et al. 2002). In addition, it is increasingly recognized that strengthening a population's resilience to environmental variability, including climate change, will require expanding habitat opportunities to allow a population to express and maintain its full suite of life history strategies (Bottom et al. 2011).

Productivity. Productivity represents the ability of a population to grow when conditions are suitable, which is essential to conservation success. In the absence of density-dependent factors, productivity is a measure of a population's ability to survive to reproduce and its reproductive success (McElhany et al. 2000). Populations that are below cohort replacement rate

or have limited ability to respond to favorable environmental conditions are less viable and at higher risk of extinction.

Spatial structure. This parameter refers to the geographic distribution of individuals in a population or populations. A population's spatial structure comprises the geographic distribution of individuals and the processes that generate that distribution (McElhany et al. 2000). The structure of a population depends on the quality of habitat available to the population, how the habitat is configured spatially, the dynamics of the habitat, and the dispersal characteristics of individuals in the population among the available habitats (McElhany et al. 2000).

The viability of salmonid populations can change over time, and NMFS considers the potential for this to occur when reviewing fish passage designs. Changes in population viability could occur from multiple factors, including the following:

- Terminating or adding new hatchery supplementation programs
- Recolonization of historical habitats after removal of a migration barrier
- Increased partitioning of the spatial structure of a population due to new barriers being installed and loss of access to habitat
- Habitat degradation and restoration
- Shifts in river hydrology and water temperature due to climate change
- Disasters (fires, landslides, etc.)
- Changes in water management

### **1.3 Migration Barriers**

Anthropogenic barriers include, but are not limited to, hydroelectric dams, water storage projects, irrigation diversions, water withdrawals, and tide gates. Dams can have significant effects on the structure and function of river ecosystems (Ward and Stanford 1979), and change in flow regulation is considered one of the most pervasive changes to rivers worldwide (Stanford et al. 1996). The effects of restricted access to migrating fish caused by dams and weirs have been broadly implicated in population declines of freshwater species around the world (Northcote 1998).

Dams can block access to habitat, eliminate habitat in the footprint of a dam and reservoir, affect the amount and timing of water flow, and result in mortality during passage (Ruckelshaus et al. 2002). Columbia River dams have blocked access to nearly 40% of the habitat historically available to salmon (NRC 1996). Construction of Hells Canyon Dam resulted in the loss of 90% of the historical spawning habitat of fall-run Chinook salmon (*O. tshawytscha*) in the Snake River, Idaho (McClure et al. 2001). In California, approximately 95% of Chinook salmon spawning habitat has been lost or is no longer accessible (Yoshiyama et al. 1996). Smaller water diversions can block access to habitats as well as cause mortality from entrainment at unscreened (or improperly screened) diversions and predation above or below the diversion. Another example, is the substantial amount of historical spawning and rearing steelhead habitat rendered unavailable in the Santa Clara River (due to the construction of dams). Santa Felicia Dam blocks 95% of the steelhead habitat within the Piru Creek watershed; more than 30 miles of stream lies between Santa Felicia Dam and Pyramid Dam (NMFS 2006 and references therein).



Dams blocking passage of steelhead to upstream habitats constitute an obstruction within a freshwater migration corridor for the species and, therefore, an impact to steelhead habitat.

In summary, some anadromous salmonid populations migrate hundreds of miles in fresh water, and barriers in their migration corridors can affect population viability (Ruckelshaus et al. 2002). This includes barriers that are complete blockages as well as barriers that are partial blockages due to localized hydraulic conditions or poorly functioning passage facilities. NMFS is responsible for evaluating the degree to which barriers affect anadromous salmonid populations and providing guidance on how to resolve any migration effects.

## 1.4 Design Process

Resolving effects on salmonid migrations from barriers involves the integration of information on fish behavior and physiology, biomechanics, hydraulic and hydrologic conditions, and civil engineering. Simply installing a fish passage structure does not constitute providing satisfactory fish passage. A successful design requires that information on each of these components be factored into the design.

Instances can also occur where a fish passage facility may not be a feasible solution for correcting a passage impediment due to biological, societal, or economic constraints. In these situations, removal of the impediment or altering project operations may be a suitable surrogate in lieu of constructing fish passage facilities (Clay 1995).

When determining whether NMFS will promote or prescribe solutions to fish passage issues, NMFS will rely on a collaborative approach that considers the views of other fisheries resource agencies, Native American tribes, non-governmental organizations, citizen groups, and other governmental agencies. The approach strives to consider fish passage objectives developed by other parties (e.g., well-placed stakeholder groups) to support fisheries restoration and habitat enhancement actions identified in conservation plans.

This document addresses design features that may provide for to the safe, timely, and effective passage of fish. It is the responsibility of the design engineer to ensure that other design requirements are met such as the structural integrity of the facility and public safety.

*This document provides specific fish passage facility design criteria and technical assistance for actions within the WCR pertaining to the various authorities of NMFS. When reviewing fish passage proposals by project proponents, NMFS will apply the criteria to major upgrades to existing facilities and the design of new fish passage facilities to the extent practicable. Existing facilities that are not compliant with this document may have to be modified using the criteria identified herein if fish passage problems are observed at these facilities. If the project is unable to meet the criteria, then the project proponent should continue to work with NOAA staff in developing a recommended solution that would best attain fish passage goals for the project.*

## **1.5 Experimental Technologies**

Experimental technologies include devices or systems that have demonstrated some potential for protecting or passing fish, but for which adequate scientific evidence has not been collected to verify effectiveness and gain agency acceptance or to be considered for general application (AFS 2000). Experimental technologies are new, innovative and unproven technologies that could be broadly applied, rather than deviations from criteria applying to a single site.

NMFS considers experimental technologies to include designs with major departures from conventional fish passage technologies as covered in this document. Experimental technologies may also include application of proven techniques to unusual environmental conditions or facility operations. Site specific deviations from criteria may not rise to the level of experimental designs, but rather warrant a conversation between the applicant and appropriate NMFS staff.

Proponents of experimental fish passage designs should provide NMFS with a sound biological or scientific basis to support the proposed design. This may include the following proof-of-concept steps as appropriate:

- A demonstrated, favorable fish behavioral response in a laboratory setting
- An acceptable plan for evaluating the prototype installation
- An acceptable alternate fish passage design developed concurrently with the unproven fish passage design that satisfies the criteria listed herein, should the prototype not perform as anticipated nor adequately protect fish

Appendix C (Experimental Technologies) provides additional information on the NMFS approval process for unproven fish passage technologies.

## **1.6 Temporary and Interim Passage**

Where construction and/or modifications to artificial impediments (e.g., dams), natural impediments (rockslides, other natural issues) or upstream passage facilities are planned, upstream and downstream passage may be adversely impacted or interrupted. If possible, these activities should be scheduled for periods when migrating fish are not present, as specified in the in-water work period allowable for construction of facilities in streams. However, this may not always be possible or advisable. In these cases, an interim fish passage plan should be prepared and submitted to NMFS for review, in advance of work in the field.

In the interim plan, upstream and downstream fish passage should be provided for any adult or juvenile fish likely to be present in the action area during construction, unless passage did not exist before construction or where the stream reach is naturally dry at the time of construction. Methods for work area isolation and dewatering, as necessary, should be determined in consultation with NMFS.

Design criteria listed elsewhere in this document also apply to the interim passage plan. Where this is not possible, project owners should seek NMFS review of alternate interim fish

passage design criteria, and a final interim passage plan. Coordination with NMFS ahead of time is advised to determine appropriate work windows and other recommended alternatives or both.

## **1.7 Section 7 Consultation under the Endangered Species Act**

This fish passage manual can be useful during ESA Section 7(a)(2) and Essential Fish Habitat (EFH) consultations. Incorporating the criteria within this document will help project proponents design projects that provide fish passage in a variety of situations. During the design process project developers can incorporate criteria within this document and work with NMFS engineers and biologists to ensure their projects meet these fish passage criteria. While this document provides substantial criteria related to fish passage, there are aspects of project design that are beyond the scope of this document. For instance, this manual does not identify or endorse specific construction best management practices. Project developers should coordinate with NMFS on project elements that fall outside the scope of this document.

This manual can also be used to achieve regulatory streamlining by aiding in the development of programmatic ESA and EFH consultations on activities involving fish passage. By incorporating these criteria into programmatic actions, action agencies and other stakeholders can help ensure their actions provide fish passage and appropriate conservation for protected resources, while streamlining the regulatory process.

## **1.8 Additional Information**

Additional information on fish passage is available at the WCR website: <http://www.westcoast.fisheries.noaa.gov/>. Questions regarding this document and requests for assistance from NMFS fish passage specialists can be directed to the following offices:

For Washington, Oregon, and Idaho:

NOAA Fisheries West Coast Region  
Environmental Services Branch  
1201 Northeast Lloyd Boulevard, Suite 1100  
Portland, Oregon 97232  
503-230-5400

For California:

NOAA Fisheries West Coast Region  
Environmental Services Branch  
777 Sonoma Avenue, Room 325  
Santa Rosa, California 95404

707-387-0737

## 2 Definition of Terms

**Anadromous** – pertaining to a fish species that displays the life history pattern known as anadromy in which adults spawn in fresh water and juveniles migrate to sea to grow to their final size and then return to fresh water to spawn (Quinn 2005).

**Active screens** – juvenile fish screens equipped with efficient mechanical cleaning capability that are automatically cleaned as frequently as necessary to keep the screens free of any debris that may restrict flow through the screen area. NMFS requires active screen designs in most cases.

**Applicant** – a person or entity that proposes to design, modify, or construct a fish passage facility at an existing or new barrier, water diversion, or water conveyance that NMFS will review under its authorities identified in Chapter 1.

**Approach velocity** – the vector component of canal velocity that is normal (perpendicular) to, and immediately upstream of, the screen surface. Approach velocity is calculated based upon the submerged area of the screen for conical screens, all cylindrical screens (torpedo, T-screen, and end-of-pipe or hose screens) where submergence and clearance criteria are met, and inclined screens where angle and submergence requirements are met. For rotary drum screens, approach velocity is the vector component of canal flow velocity that is normal to, and immediately upstream of, the vertical projection of the screen surface.

Approach velocity is a design parameter that is used to calculate the minimum amount of effective screen area required to protect fish. The amount of effective screen area required to meet screen performance criteria is calculated by dividing the maximum diversion flow by the approach velocity. Approach velocity can be measured in the field with precise flow measurement equipment, and average operating approach velocity can be calculated by dividing the measured screen flow by the effective screen area. Approach velocity should be measured as close to the boundary layer of turbulence generated by the screen face as is physically possible. Chapter 8 provides a more detailed discussion of approach velocity.

**Apron** – a flat or slightly inclined slab of concrete below a flow control structure that provides erosion protection and produces hydraulic characteristics suitable for energy dissipation or, in some cases, fish exclusion.

**Attraction flow** – flow that emanates from a fishway entrance with sufficient velocity and quantity, and in the proper location and direction, to attract upstream migrants into the fishway entrance. Attraction flow consists of gravity flow from the fish ladder and any auxiliary water system (AWS) flow added at points within the lower fish ladder.

**Auxiliary water system or auxiliary water supply system (AWS)** – a hydraulic system that augments fish ladder flow at various points in a passage facility for upstream migrating fish. Large amounts of auxiliary water flow are typically added near the fishway entrance pool to increase the amount of attraction flow emanating from the fishway entrance and the attractiveness of the entrance to fish.

**Backwash** – a system that removes debris from dewatering screens by using pressurized flow against the screen surface in the opposite direction of the approach flow.

**Backwater** – a condition whereby a hydraulic drop is influenced or controlled by a water surface control feature located downstream of the hydraulic drop.

**Baffles** – physical structures placed in the water flow path designed to dissipate energy or redirect flow to achieve more uniform flow conditions.

**Bankfull flow**– the bank height when a stream or river channel is inundated under a flow that occurs at the 1.2-year to 1.5-year average flood recurrence interval. Bankfull height may be estimated by morphological features in the channel such as: 1) a topographic break from a vertical bank to a flat floodplain or from a steep to a gentle slope; 2) a change in vegetation from bare ground to grass, moss to grass, grass to sage, grass to trees, or no trees to trees; 3) a textural change of depositional sediment; 4) the elevation below which no fine debris (e.g., needles, leaves, cones, seeds) occurs; and 5) a textural change of fine sediment deposits (matrix material) between cobbles or rocks.

**Bedload** – sand, silt, gravel, soil, and rock debris transported by moving water on or near the streambed.

**Bifurcation (trifurcation) pools** – pools in a fish ladder below which the fish ladder (and flow) is divided into two or three separate routes.

**Brail** – a device that is moved upward (vertically) through a water column to crowd fish into an area for collection.

**Bypass flow** – in the context of dewatering screen design, the portion of diverted flow that is specifically used to return fish to the river.

**Bypass reach** – the portion of the river between the point of flow diversion and where bypassed flow and fish are returned to the river.

**Bypass entrance** – an unscreened opening in a facility that fish can enter, and after which are conveyed in flow to a sampling facility or back to the stream or river. The number and locations of entrances at a facility can range from one to several and are discussed in Chapter 8.

**Bypass system** – the component of a downstream fish passage facility that conveys (transports) fish from the diverted flow back into the body of water from which they originated. Bypass systems typically consist of entrance, conveyance (flume or pipe), and outfall structures.

**Canal velocity** – the water particle speed (feet per second) in a canal flowing parallel to the streambank.

**Channel bed width** – the width of the streambed under bankfull channel conditions.

**Conceptual design** – an initial design concept based on the site conditions and biological needs of the species intended for passage, also sometimes referred to as preliminary design or

functional design. This is the first phase in the design process of a fish passage facility and is discussed in Chapter 3.

**Crowder** – a combination of static or mobile panels installed in a fishway, raceway, or holding pool for the purpose of moving fish into a specific area for sampling, counting, broodstock collection, or other purposes. Crowder panels are usually porous and constructed of perforated plate or picket bars. The panels can also be fabricated using solid, non-porous materials. Also, see the definition for picket leads in this chapter.

**Diffuser** – a system of hydraulic components arranged to control water flow rate and convert high-velocity, high-pressure, non-uniform flow into low-energy, uniform flow. A diffuser also includes one or more panels of narrowly spaced horizontal or vertical bars to prevent fish from passing through the bars and entering the area upstream of the panels.

**Distribution flume** – a channel used to route fish to various points in a fish trapping system.

**Effective screen area** – the total wetted screen area minus the area occluded by major structural elements.

**End of pipe screen** – juvenile fish screening devices attached directly to the intake of a diversion pipe.

**Entrainment** – the diversion of fish into an unsafe area or passage route.

**Exclusion barriers** – facilities that prevent upstream migrants from continuing to migrate upstream. These are typically used to prevent fish from entering areas that have no egress route or may result in fish being injured.

**Exit control section** – the upper portion of an upstream passage facility that provides suitable passage conditions to accommodate varying forebay water levels. Water level fluctuation is accommodated by adjusting the pool geometry and weir design, and by adding or removing flow at specific locations.

**False weir** – a specialized floor diffuser used to introduce water at the top of a fishway or entrance to a distribution flume for the purpose of attracting and encouraging fish to move into a specific area. The device usually creates a strong upwelling flow that cascades over a weir. Fish are attracted to the cascading flow and swim through the upwelling into a distribution flume.

**Fish ladder** – the structural component of an upstream fish passage facility (or fishway) that allows fish to move over a barrier by dissipating the potential energy caused by the head differential that results from a barrier being placed in a waterway. The ladder dissipates energy using a series of discrete pools, a series of baffled chutes and resting pools, or uniformly with a single baffled chute placed between an entrance pool and an exit pool.

**Fish lift** – a mechanical component of an upstream passage system that provides fish passage by lifting fish in a water-filled hopper or other lifting device into a conveyance structure that delivers upstream migrants past the impediment.



**Fish lock** – a mechanical and hydraulic component of an upstream passage facility that raises fish over a dam by attracting or crowding fish into a chamber, closing access to the chamber, and filling the chamber until the water surface in the lock chamber reaches (or comes sufficiently close to) the reservoir forebay level. Once at this water surface elevation, a gate to the chamber is opened, allowing fish to swim into the reservoir above the dam (Clay 1995). Fish locks can also be used as part of a trap and haul system to lift fish from the river level to a higher elevation for sorting, or transportation, or both.

**Fish passage season** – the range of dates that characterize when juvenile or adult life stages of a species will arrive at a specific location during their downstream or upstream migration. The locations could include, for example, a dam or an existing or proposed fishway.

**Fish weir** (also called picket weir, picket lead, or fish fence) – a device with closely spaced pickets or bars that allows water flow to pass, but precludes fish from migrating farther upstream. This term is normally applied to the device used to guide adult fish into a trap or counting window. This device is not a weir in the hydraulic sense.

**Fishway** – the suite of facilities, structures, devices, measures, and project operations that constitute and are essential to the success of an upstream or downstream fish passage system. The suite provides a water passage route around or through an obstruction that is designed to dissipate the energy in such a manner that enables fish to ascend the obstruction without undue stress (Clay 1995).

**Fishway entrance** – the component of an upstream passage facility that discharges attraction flow into the tailrace of a barrier and that upstream migrating fish use to enter the facility.

**Fishway entrance pool** – the pool immediately upstream of the fishway entrance(s) where fish ladder flow combines with AWS flow to form the attraction flow.

**Fishway exit** – the component of an upstream fish passage facility where flow from the forebay of the dam or barrier enters the fishway, and where fish exit the ladder and enter the forebay upstream of the dam.

**Fishway weir** – the partition that divides two pools in a fishway and passes flow between adjacent pools.

**Flood frequency** – the probable frequency that a streamflow will recur based on historical flow records. For example, a 100-year flood event refers to a flood flow magnitude that is likely to occur on average once every 100 years or has a 1% chance of being exceeded in any given year. Although calculating possible flood recurrence is often based on historical records, there is no guarantee that a 100-year flood will occur within the 100-year period, or not occur several times within that period.

**Floodplain** – the area adjacent to a stream that is inundated during periods of flow that exceed the channel capacity the stream has established over time.

**Flow control structure** – a structure in a water conveyance designed to maintain flow in a predictable fashion.

**Flow duration exceedance curve** – the plot of the relationship between the magnitude of daily flow and the percentage of time during a specific period that flow is likely to be equaled or exceeded. Flow exceedance curves may use flow data from an entire year or part of a year. For example, the 1% annual exceedance flow is the flow level exceeded 1% of the time within the entire year (i.e., 3.6 days on average), whereas the 1% exceedance flow for the fish migration window is the flow level exceeded 1% of the time during the fish passage season for a particular species and location. Exceedance values are usually derived using daily average flow data.

**Forebay** – the waterbody located immediately upstream of a dam that results from the dam impounding river flow behind the structure.

**Freeboard** – the height of a structure that extends above the maximum water surface elevation.

**Fry** – a juvenile salmonid with an absorbed egg sac that is less than 60 millimeters in total length (as defined for the purposes of this document). An embryo develops within an egg until it hatches. The hatchling (alevins) feeds off the large external yoke sac for nourishment, grows, and emerges from the spawning gravel as a fry when it can feed on its own (Quinn 2005).

**Functional design** – an initial design concept based on the site conditions and biological needs of the species intended for passage. This is also sometimes referred to as preliminary design or conceptual design. Also, see the definition for conceptual design in this chapter. The functional design commonly includes the general layout, interior dimensions, and specifications covering the hydraulic features of the fishway (Clay 1995).

**Hatchery supplementation** – hatchery programs designed for hatchery-origin fish to spawn in the wild and make a contribution to the conservation of a species or population (HSRG 2009).

**Head loss** – the irreversible reduction in total head (total energy per unit weight) of water as it flows through conduits, open channels, spillways, turbines, and other hydraulic structures. Total head is the sum of elevation head, pressure head, and velocity head. Head is described in units of length, usually in feet or meters.

**Hopper** – a device used to lift fish in water from a collection or holding area for release upstream of a barrier or into a transportation truck.

**Hydraulic drop** – the difference in total head between an upstream water surface and a downstream water surface. It includes the sums of the elevation head, pressure head, and velocity head at the upstream and downstream water surface locations. Also, see the definition for head loss in this chapter.

For fishway entrances and fishway weirs, the differences in velocity head and pressure head are usually negligible, and only water surface elevation differences are considered when estimating hydraulic drop across the structure.

**Impingement** – the condition where a fish comes in contact with the surface of a dewatering screen and remains on the screen. This occurs when the approach flow velocity immediately upstream of the screen exceeds the swimming capability of a fish given its size and condition. Impingement can injure a fish, and prolonged contact with a screen surface or bar rack can result in mortality. One objective of NMFS’ approach velocity criterion is to eliminate the possibility for healthy salmonid fry or larger fish to become impinged on a screen surface or bar rack.

**Infiltration gallery** – a facility used to withdraw surface water from beneath the streambed.

**Intermediate bypass entrance** – a bypass entrance installed upstream of the main bypass entrance. Also, see the definition of bypass entrance in this chapter. Chapter 8 provides guidelines on the number of bypass entrances needed in a bypass facility and their location.

**Invert** – the lowest inside surface of a culvert or flume.

**Kelts** – an adult steelhead that survived spawning and is migrating downstream (Quinn 2005).

**Off-ladder trap** – a facility or system for capturing fish located adjacent to a fish ladder in a flow route that is separate from the normal fish ladder route. This system allows fish to pass a barrier via the ladder or be routed into the trap, depending on the management objectives for the species or population at the facility.

**Minimum effective screen area** – the maximum screen flow divided by the allowable approach velocity.

**Passive screens** – juvenile fish screens that do not have an automated mechanical cleaning system.

**Picket leads or pickets** – a set of narrowly spaced vertical or inclined flat bars or slender circular cylinders designed to exclude fish from a specific route of passage. Picket leads are similar to diffusers, but picket leads generally lack the ability to control the flow rate or significantly alter the flow distribution. Also, see the definitions of a fish weir and crowder in this chapter.

**PIT-tag detector** – a device used to scan fish for the presence of a passive integrated transponder (PIT) tag implanted in the fish. While passing through the detector, PIT tags transmit a unique identifying number that can be read at a short distance, depending on the tag size, type, and antenna design. These passive tags operate in the radio frequency range and are inductively charged and read by the detector. They do not have a battery and can remain operational for decades.

**Plunging flow** – flow over a weir that falls into a receiving pool where the water surface elevation of the receiving pool is lower than that of the weir crest elevation. Surface flow in the receiving pool is typically in the upstream direction, downstream from the point of entry into the receiving pool. Also, see the definition for streaming flow in this chapter.

**Porosity** – the percent open area of a mesh, screen, rack, or other flow area relative to the entire gross area.

**Positive exclusion** – a means of excluding fish by providing a barrier the fish cannot physically pass through.

**Preliminary design** – an initial design concept based on the site conditions and biological needs of the species intended for passage. This is also sometimes referred to as a functional design or conceptual design. Also, see the definition for conceptual design in this chapter.

**Ramping rates** – the rate at which the water surface level at a specific point in a river is artificially altered (either increased or decreased) over a specific time period as a result of changes in the regulation of flow upstream. The rate is typically measured and stated as the change in vertical inches per hour.

**Rating curve** – graphed data depicting the relationship between water surface elevation and streamflow.

**Redd** – the nest a female salmonid excavates, deposits embryos into, and immediately buries with gravel substrate. Redds can be located in streams, rivers, or lake beaches. The locations selected vary with populations and species (Quinn 2005).

**Rotary drum fish screen** – a horizontally oriented cylinder (drum) constructed of fish screen material. Rotary drum screens include an active cleaning method and at least one fish bypass route. The drum rotates on its horizontal axis during each cleaning cycle. Debris deposited on the upstream surface of the drum is lifted by the rotating drum and washed off the downstream surface of the drum by the flow passing through the drum. Fish are guided to a bypass entrance upstream of one end of the screen array.

**Screen material** – the material that provides physical exclusion to reduce the probability of entraining fish into diverted flow. Examples of screen material include perforated plate, bar screen, and woven wire mesh.

**Scour** – erosion of streambed material resulting in the temporary or permanent lowering of the streambed profile.

**Soffit** – the inside top of culvert or underside of a bridge.

**Smolt** – a juvenile salmonid that has completed its freshwater rearing cycle and initiated a downstream migration to reach a marine environment. To prepare for seawater, the freshwater life stage (parr) undergoes a physiological and osmoregulatory transition and begins its downstream migration. Fish in this transitional stage between fresh water and marine rearing that are actively migrating downstream are termed smolts (Quinn 2005).

**Streaming flow** – flow over a weir that falls into a receiving pool and where the water surface elevation of the receiving pool is above the weir crest elevation. In these situations, surface flow in the receiving pool is typically in the downstream direction and away from the point where flow enters the receiving pool.

***Sweeping velocity*** – the vector component of water particle speed that is measured parallel to, and immediately upstream of, the screen surface.

***Tailrace*** – the portion of the water channel below a dam that conveys turbine and spillway discharge downstream from the dam.

***Tailwater*** – the body of water immediately downstream of a dam or other in-stream structure.

***Total project head*** – the difference in water surface elevation from upstream to downstream (or from the headwater to the tailwater) of a barrier such as a dam or weir. Normally, total project head encompasses a range of values based on streamflow and the operation of flow control devices.

***Thalweg*** – the streamflow path following the deepest parts (i.e., the lowest elevation) of a stream channel.

***Tide gate*** – a mechanical device that allows flow to pass in one direction but not in the opposite direction. Tide gates are often used as part of a levee or dike system to allow streamflow into a bay or estuary during ebb tides and prevent the flow of saltwater to pass in the opposite direction and enter the area upstream of the levee or dike during flood tides.

***Training wall*** – a physical structure designed to direct flow to a specific location or in a specific direction.

***Transport channel*** – a hydraulic conveyance designed to allow fish to swim between different sections of a fish passage facility.

***Transport velocity*** – the velocity of the flow within a transport channel of a fishway.

***Trap and haul*** – the collection, loading, and transportation of adult fish from a collection site at or below a barrier to a release point located upstream from the barrier or at another location, and juvenile fish from a collection site at or above a barrier to a release point located downstream from the barrier or at another location.

***Trash rack*** – a rack of vertical bars with spacing designed to catch debris and preclude it from entering the fishway or other hydraulic structure but allows fish to pass through the openings between bars. Trash racks are also referred to as a grizzly.

***Trash rack, coarse*** – a rack of widely spaced vertical bars designed to catch large debris and preclude it from entering a fishway, while providing sufficient openings between the bars to allow adult fish to exit the fishway.

***Trash rack, fine*** – a rack of narrowly spaced vertical bars designed to catch both small and large debris and reduce or eliminate the entry of fish into the intake of an AWS.

***Turbine intake screens*** – partial flow screens positioned within the upper portion of a turbine intake that guide fish entering the turbine into a collection system for transport or bypass

back to the river. Turbine intake screens are installed at most mainstem Columbia and Snake River dams operated by the U.S. Army Corps of Engineers (USACE; Appendix G).

**Upstream fish passage** – fish passage relating to the upstream migration of adult and juvenile fish.

**Upstream passage facility** – a fishway system designed to pass fish upstream of a passage impediment, either by volitional passage (i.e., under their own swimming capability) or non-volitional passage (i.e., via a lift or transport vehicle).

**Vee screens** – a pair of vertically oriented juvenile fish screens installed in a vee configuration (i.e., positioned symmetrically about a centerline), and where the bypass entrance is located at the apex of the two screens. Vee screens are also referred to as chevron screens.

**Velocity head,  $h_v$**  – the kinetic energy per unit weight of fluid due to its velocity;  $h_v$  has the units of length (usually in feet or meters) and is calculated as shown in the following equation:

$$h_v = v^2/2g$$

where:

- $v$  = velocity of the fluid (feet per second, meters per second)
- $g$  = acceleration due to gravity (32.2 feet per second<sup>2</sup>, 9.81 meters per second<sup>2</sup>)

**Vertical barrier screens** – screens located between the bulkhead (upstream) and operating (downstream) gate slots at mainstem dams on the Columbia and Snake rivers operated by the USACE. The screens keep fish diverted into the bulkhead slot by turbine intake screens from passing back into the turbine through the operating slot. Fish retained in the bulkhead gate slot by the vertical barrier screen enter a specially designed juvenile fish bypass system through orifices. (Figure G-4 in Appendix G.)

**Volitional passage** – fish passage whereby fish transit a passage facility under their own swimming capability, using timing and behavior they choose, and under all naturally passable flows. Volitional passage means fish can enter, traverse, and exit a passage facility under their own power, instinct, and swimming capability. The fish pass through the facility without the aid of any apparatus, structure, or device (i.e., they are not trapped, mechanically lifted or pumped, or transported).

**Wasteway** – a conveyance that returns excess water originally diverted from an upstream location back to the stream or channel from which it was diverted.

**Weir** – a low wall or dam built across the width of a river that pools water behind it while allowing water to flow steadily over the top of the structure.

# 3 Design Development

## 3.1 Introduction

Chapter 3 describes the general process NMFS follows and the types of information required during project design. Fish passage project designs subject to NMFS engineering review are typically developed in two major phases. The major phases are the preliminary design (Section 3.2.1), also referred to as the functional or conceptual design, and the final design (Section 3.2.2), which results in the development of detailed plans and specifications.

*A review by NMFS of an applicant's fish passage facility designs will be conducted in the context of whether they meet the recommended criteria and technical assistance listed in this document.*

Fish passage facilities refer to physical structures, facilities, or devices used to provide safe, timely, and effective passage for all life stages of fish as identified in Section 1.1 of this document. During its review, NMFS will consider site-specific information, including site limitations, biological information, and operations and maintenance (O&M) information provided by the applicant. Although the submittal of all information discussed in Chapter 3 may not be required in writing, the applicant should be prepared to describe how the biological and site information was included in the development of the project design.

## 3.2 Design Process

*Both the preliminary and final designs should be developed in cooperation and interaction with WCR biological staff from effected Branch and engineering staff from the Environmental Services Branch.*

To facilitate an iterative, interactive, and cooperative process, project applicants are encouraged to initiate coordination with NMFS early in the development of the preliminary design. Early and frequent interactions can aid in a smooth review process. NMFS' preference is to work with applicants in developing alternatives that comply with ESA. In general, NMFS cannot complete a project review of design plans that are submitted without the supporting information (listed in Section 3.3).

Project applicants should consult with NMFS on all phases of a design. Section 3.2.2 provides the minimum information needed for NMFS review. Large, complex projects will likely have multiple iterations within each of the two major design phases. As multiple design iterations are developed, each iteration should be made available to NMFS for review.

### 3.2.1 Preliminary Design

*Depending on the size and complexity of the project, NMFS typically requests that it be allowed to review and provide comments on the 30%, 60%, and 90% design iterations of the preliminary design. Due to the nature of the review process, such as applications for a FERC license and ESA consultation, a preliminary design should be developed in cooperation and interaction with biological and engineering staff from the NMFS WCR. The preliminary design should be complete and to allow the application or engineering review to move forward.*

The preliminary design establishes a preferred alternative based on comprehensive evaluations of the key elements of the design. This first phase in the design of a fish passage facility includes the following steps. Project proponents should:

1. Engage with project stakeholders and ascertain their operational requirements.
2. Identify and prioritize project objectives and the associated functional requirements.
3. Assemble the design criteria of the federal, state, and tribal fish resource agencies.
4. Collect pertinent biological, hydrological, and engineering information.
5. Develop appropriately scoped geomorphic assessments for the project.
6. Define project reliability and backup or contingency parameters.
7. Develop a process for evaluating and ranking alternative designs and operations.
8. Generate alternative designs and select the preferred alternative.
9. Develop initial layout drawings and models as needed to describe the facility.
10. Describe the operational requirements of the major facility sub-components

The preliminary design results in a facilities layout that includes section drawings and the identification of component sizes and water flow rates for the primary project features. Cost estimates are also included in the preliminary design. Completion of the preliminary design commonly results in a document that may be used for budgetary and planning purposes and for soliciting (and subsequently collating) design review comments provided by other reviewing entities. The preliminary design is usually considered to be at the 20% to 30% completion stage of the design process. The preliminary design may include the following sub-phases of design work:

- Reconnaissance study: Typically, this study investigates the optimal design and construction specific to each site. The study usually occurs early in the preliminary design process.
- Conceptual alternatives study: This study lists the types of facilities that may be appropriate for accomplishing the fish passage objectives at a selected site. It does not entail much on-site investigation. Its purpose is to develop a narrowed list of alternatives that merit additional assessment.
- Feasibility study: This study includes an incrementally greater amount of development of each design concept (including a preliminary cost estimate) than does the conceptual alternatives study. It enables the most-preferred alternative to be identified.

### 3.2.2 Detailed or Final Design

*The final design should be based on the preliminary design that NMFS reviewed. Any significant deviation from the accepted preliminary design will trigger a new review. Once the detailed design process commences, NMFS should have the opportunity to review and provide*



*comments on the designs developed at the 30%, 60%, 90%, and 100% stages, or near each of these stages.*

*The details of the final design phase uses the preliminary design as a springboard for beginning the final design and specifications in preparation for the bid solicitation (or negotiation) process. NMFS reviews usually provide refinements in the detailed design that will lead to O&M and fish safety benefits. Electronic drawings are the preferred review medium, though NMFS may request scaled 11-by-17-inch paper drawings in addition to electronic media.*

### **3.2.3 Smaller Projects**

*For smaller projects where the review process may involve only one or two steps, each submittal to NMFS should include enough information about the project to ensure that the reviewing engineer is able to discern the goals of the project, any biological and physical constraints of the project, and how the proposed design intends to meet the goals of the project given constraints that were identified.*

### **3.2.4 Review Timelines**

*NMFS should be allowed at least 30 days to review and comment on each stage of the design process (30%, 60%, 90%, and 100%).*

Although NMFS may waive or voluntarily shorten a review period for a specific stage, project applicants should develop their design schedules using the standard 30-day review period for each stage of the design.

## **3.3 Information Requirements**

*The design of all fish passage facilities should be developed based on a synthesis of the required site and biological information listed below, with a clear understanding of how the facility will be operated and maintained. The following project information is needed for, and should be provided with, the preliminary design. In some cases, NMFS may need additional information not listed herein.*

### **3.3.1 Functional Requirements**

The project design should describe the functional requirements of the proposed fish passage facilities as related to all anticipated project operations and streamflows. The design should describe the expected median, maximum, and minimum monthly diverted flow rates and any special operations (e.g., the use of flash boards) that modify forebay or tailrace water surface elevations.

### **3.3.2 Site and Physical Information**

The following physical information should be provided and used in developing the project design.

### **3.3.2.1 Plans**

Design submittals should include visual representations of various project features. These plans may include any or all of the following:

- Site plan drawings: Showing the location and layout of the proposed fish passage facility relative to existing project facility features
- Surveys: Topographic and bathymetric surveys, particularly where they might influence locating fishway entrances and exits and personnel access to the site
- Additional drawings: Drawings of existing facilities illustrating longitudinal profile, elevations, and plan views, including details showing the intake configuration, location, and capacity of the project's hydraulic features
- Project Location Map including nearby town and north arrow along with Latitude and Longitude
- Temporary passage facility drawings: Drawings demonstrating plans for temporary or interim passage during construction of the primary facility. These temporary facilities should provide passage at a level no worse than existed prior to commencing construction on primary facility.

### **3.3.2.2 Hydrology**

*Design submittals should include information on the hydrology of the basin—including daily and monthly streamflow data and flow duration exceedance curves at the proposed site for a fish passage facility—based on the entire period of available records, which may be modified based upon site specific issues as approved by NMFS staff.*

If stream gage data are unavailable for a proposed facility location (or if records exist for only a brief period of time), flow records may be generated using synthetic methods to develop the necessary basin hydrology information, which is used to develop the high and low fish passage design flows for the project (Chapter 4).

### **3.3.2.3 Project operations and basic information**

*Information on project operations that may affect fish migration should be provided.*

Project information is key to understanding basic design parameters for fish passage (both for baseline conditions and for future fish passage changes). This could include information on powerhouse flow capacity, periods of powerhouse operation, turbine sequencing, debris management, flashboard or crest gate operation, flood or waster gate operation staffing levels, planned outages, pulse flows, project forebay and tailwater rating curves that encompass the entire operational range of the project, water temperature etc.

### **3.3.2.4 Morphology**

*Information on the stream or river channel at the site of the fish passage project should be provided, and includes but is not limited to the following:*

- *Determine the potential for channel degradation, aggregation/subsidence, or channel migration, which may alter stream channel geometry and compromise fishway performance (if the fish passage facility is proposed at a new or modified diversion).*
- *Describe whether the stream channel is stable, conditionally stable, or unstable.*
- *Identify the overall geomorphology of the channel (e.g., straight, meandering, or braided).*
- *Provide the rate of lateral channel migration and change in stream gradient that has occurred during the last decade if migration is evident or likely to occur in the future using aerial photography, anecdotal information, or physical monitoring.*
- *Describe the effect the proposed fish passage facility may have on the existing stream alignment and gradient.*
- *Describe the potential for future channel modification to occur; this could be from construction of the facility or natural channel processes (i.e., instability).*
- *Describe the substrate of the channel and provide the D50.*

### **3.3.2.5 Sediment and debris**

*Any sediment and debris conditions that may influence the design of the fish passage facility or present potentially significant problems should be described.*

### **3.3.3 Biological Information**

Section 3.3.3 outlines miscellaneous information that should be provided and used in developing the project design. Contact the NMFS biologist in your area to determine which of the following is needed for the project.

#### **3.3.3.1 Salmonid biological information**

The following biological information should be provided for site specific conditions:

- Salmonid species present in the basin that are affected by the project, or are expected to be in the basin in the future
- Approximate abundance of each salmonid species and run (e.g., winter, spring, summer, fall, and late fall)
- Various life stages present, or expected to be present, in the future and their migration timing (fish passage season)
- Location and timing of spawning in the basin
- Location and timing of juvenile downstream migration

#### **3.3.3.2 Non-salmonid passage**

Information on any non-salmonid species (and life stages) present at the proposed fish passage site should be provided to address passage requirements for these species.

#### **3.3.3.3 Predation risk**

Information on predatory species that may be present at the proposed site should be provided along with information on conditions that favor or help to prevent their preying on

salmonids. Information should include, but is not limited to, species type, life stage, spawning ground, and location of predator habitat.

#### **3.3.3.4 Fish behavior characteristics**

Any known fish behavioral traits of salmonid or non-salmonid passage that might affect the design of the facility should be provided.<sup>1</sup>

#### **3.3.3.5 Additional research needs**

Any uncertainty associated with how migrating fish approach the site where a new facility is being considered should be identified through directed studies, including routes fish may use when approaching the site. For more information related to large projects, see Appendix G.

#### **3.3.3.6 Streamflow requirements**

The minimum streamflow required to allow migration around the impediment during low water periods (See Design Flow Range in Chapter 4).

#### **3.3.3.7 Poaching risk**

The degree of poaching or illegal trespass activity in the immediate area of the proposed facility should be identified, along with any security measures needed to reduce or eliminate illegal activity.

#### **3.3.3.8 Water quality**

Water quality factors that may affect fish passage at the site should be described. For example, fish may not migrate if water temperature and quality are marginal and may instead seek coldwater refugia (e.g., deep pools fed by groundwater) or holding zones where dissolved oxygen levels are higher than surrounding reaches until water quality conditions improve. Water temperature issues are important considerations that can effect design. Therefore, it is also important to document other temperature issues (eg. reservoir stratification, or effluent releases in the project area, among other issues).

### **3.3.4 Operations and Maintenance Information**

*In order to provide a degree of certainty that necessary maintenance will be funded and performed, the following O&M information should be provided for in development of the preliminary design.*

Historically, many fish passage facilities have been built and have subsequently fallen into disrepair due to improper operations or lack of maintenance or funding. New project designs

---

<sup>1</sup> For example, most salmonid species pass readily over a fishway weir with either plunging or streaming flow. However, pink and chum salmon have a strong preference for streaming flow conditions and may reject plunging flow. Therefore, if pink or chum salmon are in the basin, this needs to be identified. Similarly, American shad prefer streaming flow conditions and generally reject both plunging flow and orifice passage.

should consider the need for proper operations and long-term maintenance. Start up, daily, and yearly maintenance procedures, daily logs, and annual reports should be considered in the design development and included as part of the O&M plan.

#### **3.3.4.1 Maintenance funding**

*The O&M plan should identify the party responsible for funding the O&M of the proposed facility.*

#### **3.3.4.2 Operating and maintaining entity**

*The O&M plan should identify the party responsible for operating the facility and carrying out maintenance actions.*

#### **3.3.4.3 Facility shutdown**

*The O&M plan should describe maintenance actions that will require the facility to be taken out of service and the timeline for these actions.*

#### **3.3.4.4 Schedule of operations**

*The O&M plan should identify the proposed schedule of operations for intermittently operated facilities, such as weirs or traps, and the accompanying plans for salvaging fish from these facilities after they are operational. This should include plans for how the facility will be dewatered and how salvaged fish will be returned to the stream or river.*

## 4 Design Flow Range

Prior to determining the fish passage design flows, the steps in the 2022 NOAA Fisheries WCR Guidance to Improve the Resilience of Fish Passage Facilities to Climate Change should be followed to determine what if any climate impacts should be considered and included in the design. The guidance in Chapter 4 applies to projects located in Washington, Oregon, and Idaho over the range of anadromous salmonid habitat. Due to significantly different hydrologic conditions in California, project proponents should work with NMFS engineering staff to determine the appropriate design flows for site conditions.

### 4.1 Introduction

A fishway design and facility must allow for the safe, timely, and efficient passage of fish within a specific range of streamflow. The design streamflow range is bracketed by the designated fish passage design low flow and high flow described in Sections 4.2 and 4.3.

*Within the design streamflow range, a fish passage facility should operate within its specific design criteria. Outside of the design streamflow range, fish should either not be present, not be actively migrating, or should be able to pass safely without need of a fish passage facility.*

Site-specific information is critical to determining the design time period and river flows for the passage facility—local hydrology may require that the design streamflow range be modified for a particular site.

### 4.2 Design Low Flow for Fish Passage

*Design low flow for fishways is the average daily streamflow that is exceeded 95% of the time during periods when migrating fish are normally present at the site.*

This is determined by summarizing the previous 25 years of mean daily streamflow occurring during the fish passage season, or by an appropriate artificial streamflow duration methodology (if streamflow records are not available). Shorter data sets of streamflow records may be useable if they encompass a broad range of flow conditions. The fish passage design low flow is the lowest streamflow for which migrants are expected to be present, migrating, and dependent on the proposed facility for safe passage.

### 4.3 Design High Flow for Fish Passage

*Design high flow for fishways is the average daily streamflow that is exceeded 5% of the time during periods when migrating fish are normally present at the site.*

This is determined by summarizing the previous 25 years of mean daily streamflow occurring during the fish passage season, or by an appropriate artificial streamflow duration methodology (if streamflow records are not available). Shorter data sets of streamflow records

may be used if they encompass a broad range of flow conditions. The fish passage design high flow is the highest streamflow for which migrants are expected to be present, migrating, and dependent on the proposed facility for safe passage.

#### **4.4 Fish Passage Design for Flood Flows**

*The general fishway design should have sufficient river freeboard to minimize overtopping by 50-year flood flows.*

Above a 50-year flow event, fishway operations may include shutdown of the facility to allow the facility to quickly return to proper operation when the river drops to within the range of fish passage design flows. Other mechanisms to protect fishway operations after floods will be considered on a case-by-case basis. A fishway should never be inoperable due to high river flows for a period greater than 7 days during the migration period for any anadromous salmonid species. In addition, the fish passage facility should be of sufficient structural integrity to withstand the maximum expected flow. It is beyond the scope of this document to specify structural criteria for this purpose. If the fish passage facility cannot be maintained, the diversion structure should not operate, and the impediment should be removed.

# 5 Upstream Adult Fish Passage Systems

## 5.1 Introduction

Chapter 5 provides criteria and guidelines for designing upstream adult fish passage facilities as well as selecting appropriate ladder types for specific site conditions. These criteria and guidelines apply to adult upstream fish passage facilities in moderately sized streams. Where applicable, supplementary criteria for facilities located in small streams will be noted. Chapter 5 does not address fish passage systems, such as fish locks and mechanical lifts, which may provide passage over barriers or be used as part of a trap and haul system. Fish lifting devices are covered in Section 7.6.

Chapter 5 also discusses upstream passage impediments, which are artificial or natural structural features or project operations that cause adult or juvenile fish to be injured, killed, blocked, or delayed in their upstream migration to a greater degree than in an unobstructed river setting. These impediments can present total or partial fish passage blockages. Artificial upstream passage impediments require approved structural and operational measures to mitigate, to the maximum extent practicable, for adverse impacts to upstream fish passage. These impediments require a fish passage design based on conservative criteria because the natural complexity of streams and rivers that usually provide passage opportunities has been substantially altered. The criteria in this chapter also apply to natural barriers, when passage over the barrier is desired and consistent with watershed, subbasin, or recovery plans.

Examples of passage impediments include, but are not limited to, the following:

- Permanent or intermittent dams
- Hydraulic drops over artificial instream structures<sup>2</sup> in excess of 1.5 feet
- Weirs, aprons, hydraulic jumps, or other hydraulic features that produce depths of less than 10 inches, or flow velocity greater than 12 feet per second (ft/s) for more than 90% of the stream channel cross section
- Conditions that create false attraction, including the following:
  - Project operations or features that lead upstream migrants into impassable routes
  - Discharges that may be detected and entered by fish with no certain means of continuing their migration (e.g., poorly designed spillways, cross-basin water transfers, canal wasteways, or unscreened diversions) or have the potential to result in mortality or injury (e.g., turbine draft tubes, shallow aprons, and flow discharges)
- Insufficient flow, which includes the following:
  - Diffused or braided flow that impedes approach to the impediment

---

<sup>2</sup> This is based on the *Fisheries Handbook of Engineering Requirements and Biological Criteria* (Bell 1991), which recommends using fishways for head differences as low as 2 feet.



- Insufficient flow in a bypass reach, such that fish cannot enter or are not stimulated to enter the reach and move upstream; bypass reaches are commonly located adjacent to a powerhouse or wasteway return
- Water diversions that reduce instream flow
- Poorly designed headcut control or bank stabilization measures that create poor upstream passage conditions such as those listed above
- Degraded water quality in a bypass reach, relative to the water quality downstream of the confluence of bypass reach and flow return discharges (e.g., at the confluence of a hydroelectric project tailrace and bypass reach)
- Ramping rates in streams or in bypass reaches that delay or strand fish
- Upstream passage facilities that do not satisfy the criteria and guidelines described in Chapter 5

The typical components of an upstream adult fish passage system are shown in Figure 5-1.

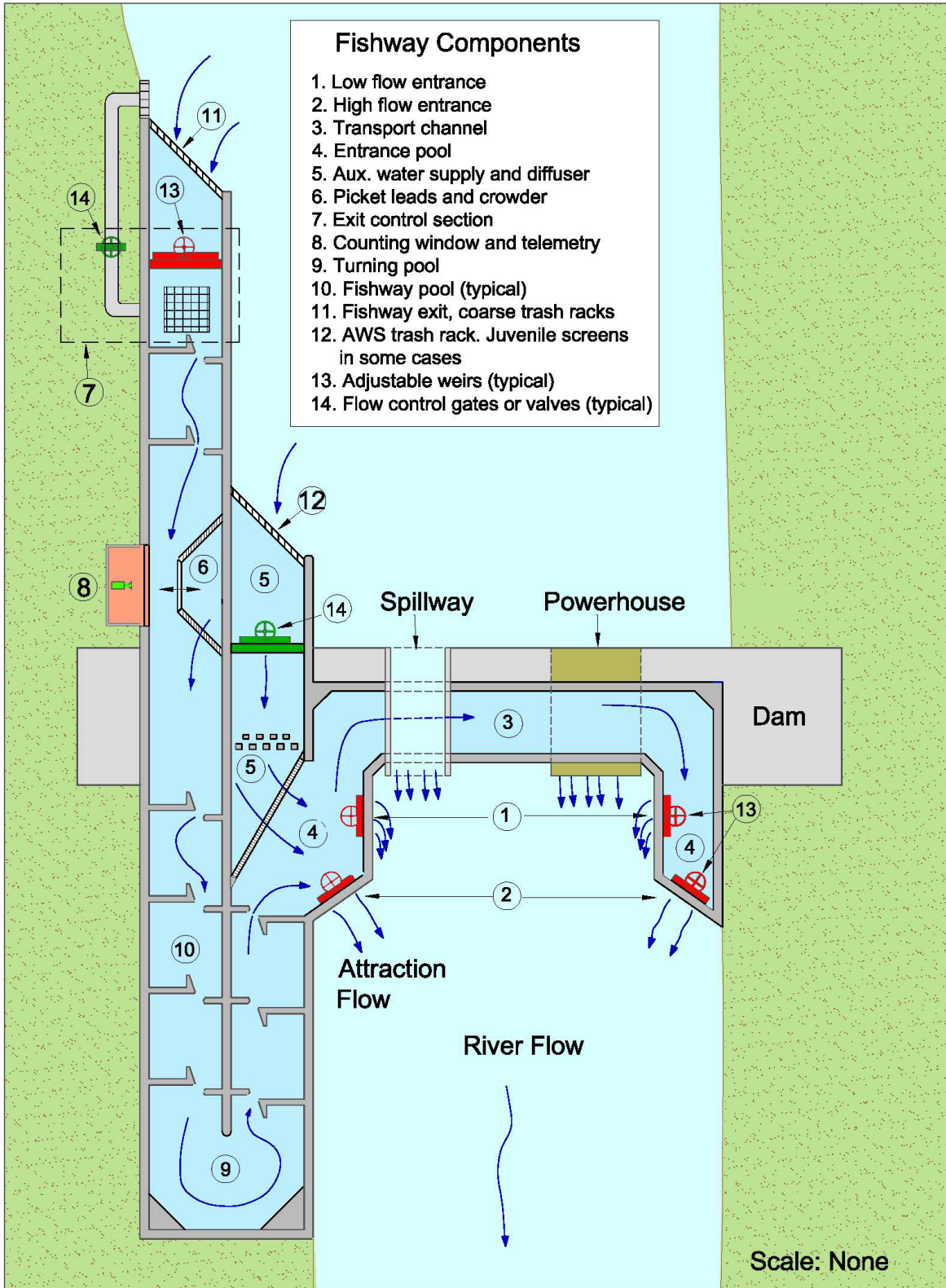

Figure 5-1. Components of vertical slot fishway for upstream passage

### 5.1.1 Passage Alternatives: Volitional and Non-volitional

*Volitional passage is preferred for passage facilities over non-volitional passage. Non-volitional systems may be considered where volitional passage facilities are not feasible due to significant engineering constraints or biological limiting conditions.*

NMFS typically prefers volitional fish passage as these systems afford passage opportunities for migrating fish at all times, and fish can transit a passage facility under their own swimming capability, using timing and behavior they choose, and under all naturally passable flows. Volitional passage means fish can enter, traverse, and exit a passage facility under their own power, instinct, and swimming capability. The fish migrate through a volitional passage facility without the aid of any mechanical apparatus, structure, or device.

Volitional passage systems at dams usually consist of hydraulically engineered fish ladders that use one of the designs described in this manual. Under certain site conditions, a volitional passage system for a dam of low or moderate height may be designed as a nature-like channel; or it may be a hybrid design that incorporates features of both nature-like and traditional designs. Volitional systems for applications other than dams generally seek to emulate nature-like conditions with stream simulation techniques.

There are some situations where a volitional passage system is infeasible due to biological factors, engineering constraints, fish management objectives, or other project-specific limitations. In these instances, non-volitional systems may be appropriately considered to meet fisheries management goals and objectives, provided they are designed, constructed, and operated following the guidance in chapter 7 of this Manual.

Non-volitional systems, due to long term operations and maintenance requirements, can have higher total life-cycle costs when compared to fish ladders. Project proponents should carefully weigh the pros and cons of the different alternative modes of passage to select the most appropriate design that will consistently accomplish the project's fish passage goals. There may be instances where the inability of a project proponent to consistently and correctly operate and maintain a proposed collection and transport system represents an unacceptable risk to the managed fish species.

Although site specific challenges exist, non-volitional designs can be a viable management tool that provides Pacific salmonids access to some historic habitats, including cold-water sites that will be increasingly important given climate projections.

### 5.1.2 Passage of Other Species

*Where appropriate, upstream adult fish passage systems should incorporate passage requirements for other species (e.g., shad, sturgeon, Pacific lamprey, and suckers) that may use the system, provided that the changes do not compromise the passage of target species (salmonids).*

Failure to account for the passage requirements of other species may create a biological blockage in the ladder that could delay or compromise the passage of the target species. For

example, if American shad (*Alosa sapidissima*) cannot pass a fishway, the numbers of shad in the fishway may build up to the point where other fish do not enter or move through the fishway.

### **5.1.3 Temperature Considerations**

In certain cases, water temperature control may be a critical factor for fish ladder designs, particularly at high head dams. Some reservoirs or head ponds may become thermally-stratified at some point during the fish passage season, resulting in a potential temperature mismatch between the fish ladder's discharge and the dam's other tailwater or tailrace discharges. Also, during summer seasons, water temperature may increase as water passes through long fish ladders whose exterior concrete surfaces are exposed to solar energy for a considerable period of time. Such temperature mismatch situations may cause salmonids (or other species) to reject the fish passage route. To the degree these conditions exist, artificial temperature modulation at fishways and ladders may be necessary (Caudill et al. 2013).

## **5.2 Fishway Entrance**

### **5.2.1 Description and Purpose**

A fishway entrance is a gate or slot through which fishway attraction flow is discharged in a manner that encourages and allows adult fish to enter the upstream passage facility. The fishway entrance is often the most difficult (Bates 1992)—yet most critical—component to design for an upstream passage system, particularly at dams (Clay 1995). Fishway entrances should be placed to ensure that fish are attracted to and enter the best passage routes past the passage impediment throughout the entire design flow range. The most important aspects of fishway entrance design are as follows:

- Location of the entrance
- Pattern and amount of flow from the entrance
- Approach channel immediately downstream of the entrance
- Flexibility in adjusting entrance flow to accommodate variations in tailrace elevation, stream or river flow, and project operations

### **5.2.2 Specific Criteria and Guidelines – Fishway Entrance**

#### **5.2.2.1 Configuration and operation**

*Unless otherwise approved by NMFS, at sites where the entrances are located in deeper water, fishway entrances should be equipped with downward-opening slide gates or adjustable weir gates that rise and fall with the tailwater elevation. At locations where the tailwater is not deep, orifice entrances or downward-closing slide gates (which create an orifice entrance) may be used. The entrance gate should be able to completely close off the entrance when not in use. Gate stems or other adjustment mechanisms should not be placed in any fish migration pathway. Fishway entrance gates operating in an orifice configuration should not be closed to an opening height less than 12-inches except when fully closed.*

The fishway entrance gate configuration and its operation may vary based on site-specific project operations and streamflow characteristics. Entrance gates are usually operated in either a

fully open or fully closed position, with the operation of the entrance being dependent on tailrace flow characteristics. Sites with limited tailwater fluctuation may not require an entrance gate to regulate the entrance head, while other sites may maintain proper entrance head by regulating auxiliary water flow through a fixed-geometry entrance gate.

#### **5.2.2.2 Location**

*Fishway entrances should be located at points where fish can easily locate the attraction flow and enter the fishway. When choosing an entrance location, high-velocity and turbulent zones in a powerhouse or spillway tailrace should be avoided in favor of relatively tranquil zones adjacent to these areas. A site-specific assessment must be conducted to determine entrance location and entrance jet orientation. A physical hydraulic model is often the best tool for determining this information (Bell 1991).*

*The fishway entrance should be located as far upstream as possible since fish will seek the farthest upstream point (Bell 1991). This is especially the case with low flow entrances. This guideline is subject to adjustment by NMFS based on site-specific constraints that include the configuration of the project, flow level, and flow patterns associated with powerhouse or facility operations and spill discharge in relation to site conditions.*

*Some fishway entrances at a project should be located on the shoreline (Bell 1991). This is because fish orient to shorelines when migrating upstream. Locating an entrance on the shoreline takes advantage of this behavior, where the shoreline serves to lead fish to the entrance.*

One of the most significant design decisions for a fishway entrance is its location (WDFW 2000). Turbulence can be a barrier to fish passage because velocities, turbulence, upwells, reverse currents, and aeration can affect attraction and access to fishways (WDFW 2000). At locations where the tailrace is wide, shallow, and turbulent, excavation to create a deeper, less-turbulent holding zone adjacent to the fishway entrance(s) may be necessary. Therefore, it is important to fully characterize and understand flow patterns when locating a fishway entrance at a site.

#### **5.2.2.3 Additional entrances**

*If the site has multiple zones where fish accumulate, each zone should have a minimum of one fishway entrance. For long powerhouses or dams, additional entrances may be required. Multiple entrances are usually required at sites where the high and low design flows create different tailwater conditions. All entrances should meet the requirements of Section 5.2.*

Since tailrace hydraulic conditions usually change with project operations and hydrologic events, it is often necessary to provide two or more fishway entrances to accommodate the differences between high- and low-flow river conditions (often referred to as high- and low-flow entrances). When switching between high- and low-flow conditions, it is often necessary to close some entrances that are operating poorly or those the fish can no longer access, and open others where fish are congregating and holding. These features should be designed so that entrance changes can be performed simply, swiftly, and easily.

#### 5.2.2.4 Attraction flow

*Additional attraction flow from the fishway entrance is needed to extend the area of intensity of velocity of the outflow (from the entrance) to increase fish attraction into the entrance (Clay 1995). Attraction flow from the fishway entrance should be between 5% and 10% of the fish passage high design flow (Chapter 4). For smaller streams, NMFS may conclude that attraction flows up to 100% of streamflow may be required.*

Larinier et al. (2002) conclude that a major cause of poor fishway performance is a lack of adequate attraction flow. At dams, the entrance flow for fish attraction should be sufficient to compete with spillway or powerhouse discharge flow (Bates 1992). Generally speaking, the higher the percentages of total river flow used for attraction into the fishway, the more effective the facility will be in providing upstream passage. The proportion of attraction flow needed is based on extensive research and results of laboratory studies.<sup>3</sup> The proportion selected should be sufficient to allow fish to both find and want to enter fishway entrances.

Under conditions where ladder entrances are optimally situated near the impediment and fish are naturally led to an entrance, an attraction flow of 5% of the fish passage design flow is used. However, some situations may require that more than 10% of the passage high design flow be used. For example, if a site features obscure approach routes to the passage facility or if entrances are located in a less than optimal location, a higher proportion of the design flow is needed as attraction flow. Additionally, facilities with multiple entrances may require more attraction flow (not to exceed a total of 10% of the fish passage design flow).

Powerhouse and spillway flows are not considered part of the proportion of project flow used for fishway attraction. Powerhouse and spillway flows should be shaped, and turbine unit and spill gate operation prioritized, to create tailrace conditions that naturally lead to and allow fish to rapidly locate the fishway entrances (Bell 1991).

#### 5.2.2.5 Hydraulic drop

*The fishway entrance hydraulic drop (also called entrance head) should be maintained between 1 and 1.5 feet, depending on the species present at the site, and designed to operate from 0.5 to 2 feet of hydraulic drop (USFWS 1960; Junge and Carnegie 1972).*

A range of 1 to 1.5 feet is considered a normal operating range that helps establish streaming flow conditions (Bates 1992). Gauley et al. (1966) found in laboratory studies that Chinook salmon and steelhead made significantly faster ascents up an experimental ladder with orifice flow and flow over a weir when head on the weir was increased from 0.95 to 1.2 feet.

The hydraulic drop criterion is based in part on results of laboratory studies where an increasing number of Chinook and sockeye salmon and steelhead failed to enter all entrances tested when head was increased from 2 to 3 feet. Pink and chum salmon have more specific

---

<sup>3</sup> For example, Weaver (1963) conducted a study wherein he provided salmon and steelhead with a choice of entering adjacent channels of the same width but different velocities; a higher proportion chose to enter the channel with higher velocity.

requirements. Fish from these species can easily swim through an entrance with 1.5 feet or more of head differential, but they will not jump even a portion of that height (Bates 1992).

#### **5.2.2.6 Dimensions**

*For larger streams, the minimum fishway entrance width should be 4 feet, and the entrance depth should be at least 6 feet, although the shape of the entrance is dependent on attraction flow requirements and should be shaped to accommodate site conditions.*

*For smaller streams, the ladder entrances should be as large as possible, consistent with available fishway entrance flow, to maximize fish attraction and minimize plugging by debris. The minimum size for an orifice-style entrance should be 1.5 feet by 1.5 feet. The minimum width for a vertical slot-style entrance should be 1.25 feet if large Chinook salmon are present and 1 foot otherwise, and the depth (i.e., bottom of the slot to the tailwater level) should be at least 2 times the slot width.*

*In general, the dimensions of the fishway entrance should create a compact, strong attraction flow jet that projects out of the entrance a significant distance into the tailrace.*

For identical water velocities, attraction jets created by entrances that are small, narrow, and deep, or are wide and shallow, do not project as far into the tailrace as does a compact entrance (Section 5.2.2.8; also, see requirements for mainstem Columbia and Snake rivers in Appendix G). The entrance width criterion is based partly on results of laboratory studies where Chinook salmon and steelhead preferred 3.9-foot-wide entrances over 1.5-foot-wide entrances under a constant velocity condition of 8 ft/s and lighted conditions. However, under dark conditions, all of these species preferred the wider opening, and coho salmon preferred the wider opening under both lighted and dark conditions (Weaver et al. 1976).

For ladder entrances at facilities located in small streams, orifice size is based on the minimum orifice size for an Ice Harbor-style ladder (Section 5.5.3.3). For a slot-style entrance at a facility in a small stream, the slot width is based on the minimum slot widths for vertical slot ladders (Section 5.5.2.1.1), and the minimum depth is based on the square area of a 1.5-foot by 1.5-foot orifice. For example, the criterion above states that slot depth (the depth from the bottom of the vertical slot-style entrance to the tailwater water surface elevation) should be double the slot width, and the minimum width should be 1.25 feet if large Chinook salmon are present and 1 foot otherwise. Therefore, when sizing a 1-foot-wide slot, the design should submerge the slot 2 feet, which is close to the 2.25 square foot (ft<sup>2</sup>) open area of a 1.5-foot by 1.5-foot orifice.

#### **5.2.2.7 Types of entrances**

*Fishway entrances may be adjustable submerged weirs, vertical slots, orifices, or other shapes, provided that the requirements specified in Section 5.2.2 are achieved.*

Care should be taken to select a fishway entrance that generates a good attraction jet and is passable by all species of interest (Junge and Carnegie 1972). For example, American shad typically refuse to pass through orifices. Therefore, at sites where American shad are present, orifice entrances should be avoided, and surface routes in fishways are required (Larinier et al. 2002). This is true of all species in the genus *Alosa*. Also, American shad orient to walls when

migrating through fishways and can be trapped in corners if no surface-oriented route is available (Junge and Carnegie 1972; Bell 1991; WDFW 2000).

### 5.2.2.8 Flow conditions

*The fishway entrance should create either streaming flow or hydraulic conditions similar to a submerged jet.*

The desired flow condition for entrance weir and slot discharge jet hydraulics is streaming flow (WDFW 2000). A streaming flow is an intact plume of water moving almost horizontal near the water surface or at the elevation of an orifice entrance. In contrast, plunging flow drops vertically over an entrance sill or weir and then upwells downstream a few feet from an entrance. Plunging flow sets up a hydraulic roll where surface flow is moving in an upstream direction toward the entrance (Figure 5-2). This induces fish to jump at the flow, which may cause injuries, and it presents hydraulic conditions that some species may not be able to pass or may refuse to pass. This includes American shad and pink and chum salmon. Plunging flow also directs the attraction jet downward toward the stream bottom rather than across the tailrace. Streaming flow may be accomplished by placing the entrance weir (or invert of the slot) elevation such that flow over the weir falls into a receiving pool with a water surface elevation above the weir crest elevation (Katopodis 1992).

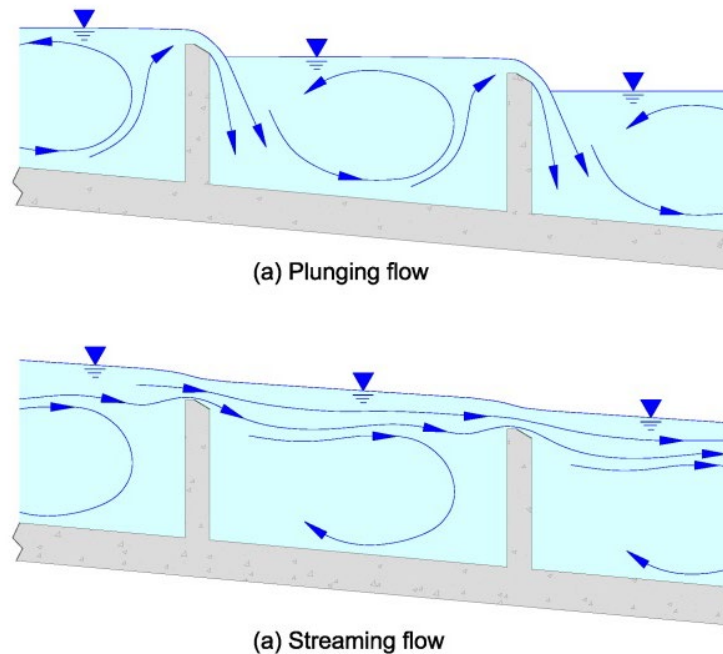

**Figure 5-2. Plunging (a) and streaming (b) flows in pool and weir style of fishways**

### 5.2.2.9 Orientation

*Generally, low-flow entrances should be oriented nearly perpendicular to the streamflow (Figure 5-1; Bates 1992). High-flow entrances should be oriented to be more parallel to streamflow or at an angle away from the shoreline (Figure 5-1). A site-specific assessment should be conducted to determine entrance location and entrance jet orientation.*



Low-flow entrances are designed to be used by fish during periods when flow conditions approach the low design flow. They are generally the entrances furthest upstream and closest to the passage barrier. High-flow entrances are designed for use during periods when flow conditions approach the high design flow. Bates (1992) suggests that high-flow entrances be placed at a 30-degree angle to the high-flow streamline, ideally along the edge of a high-flow hydraulic barrier. In general, high-flow entrances are located slightly downstream from the barrier at a point in the tailrace where the turbulence from the barrier under high flow conditions has just dissipated. A physical hydraulic model is often the best tool for determining this information; this model is used to test various design alternatives that favor fish passage (Bell 1991).

#### **5.2.2.10 Staff gages**

*The fishway entrance design should include staff gages to allow for a simple determination of whether the entrance head criterion (Section 5.2.2.5) is met. Staff gages should be located in the entrance pool and in the tailwater just outside of the fishway entrance in an area visible from an easy point of access. Gages should be readily accessible to facilitate in-season cleaning.*

Staff gages are important tools for determining whether a fish ladder entrance is meeting criteria. Care should be taken when locating staff gages to avoid placement in turbulent areas and locations where flow is accelerating toward a fishway entrance.

#### **5.2.2.11 Entrance pools**

*The fishway entrance pool should be designed to combine ladder flow with auxiliary water system (AWS; also known as auxiliary water supply system) flow in a manner that encourages fish to move from the entrances in an upstream direction and optimizes the attraction of fish to lower fishway weirs.*

The fishway entrance pool is at the lowest elevation of the upstream passage system. It discharges flow into the tailrace through the entrance gates to attract upstream migrants. In many fish ladder systems, the entrance pool is the largest and most important pool in terms of providing proper guidance of fish from the entrance to the ladder section of the upstream passage facility. Ladder flow and AWS flow through diffuser gratings are combined in the pool to form the entrance attraction flow (Section 5.3, Figure 5-1).

Attraction to the lower fishway weirs may be optimized by the following:

- Shaping the entrance pool to create a natural funnel leading fish to the ladder weirs
- Angling vertical AWS diffusers toward the ladder weirs
- Locating the jet from the ladder weir adjacent to the upstream terminus of the vertical AWS diffusers

The pool geometry will normally influence the location of attraction flow diffusers.

### **5.2.2.12 Transport velocity**

*Transport velocities between the fishway entrance and first fishway weir, fishway channels, and over-submerged fishway weirs should be consistent with the guidance found in section 5.4.2.1.*

Gauley et al. (1966) reported that Chinook and sockeye salmon and steelhead passage times did not differ significantly between water velocities of 1 and 4 ft/s in an experimental 270-foot-long transportation channel. However, Weaver (1963) reported that Chinook salmon moved progressively slower in a test flume as velocities increased from 2 to 8 ft/s.

Note that as tailwater level rises and the lower fishway weirs become submerged, it becomes necessary to increase the flow in this area of the ladder to meet the transport velocity criterion (Bell 1991).

An AWS can be used to supply additional water through wall or floor diffusers. Care should be taken to design the fishway weirs that will be submerged to accommodate the additional flow in the ladder so that other fish passage (or hydraulic) criteria are not exceeded. The transport channel velocity guidelines do not apply to individual ladder pools since these are governed by design criteria specific to these pools.

## **5.3 Auxiliary Water Systems**

### **5.3.1 Description and Purpose**

*An AWS should be used to supply additional water to the fishway when the required attraction flow (as specified in Section 5.2.2.4) is greater than ladder flow.*

Auxiliary water is often required at fishways to provide additional attraction flow from the entrance pool to fishway entrances (Bell 1991). Adding AWS flow is based on the concept that fish migrating upstream are attracted by flow velocity of certain magnitudes, which the fish swim against to continue their migration upstream (Clay 1995). Auxiliary water can also be supplied through an AWS to areas between fishway weirs that are partially submerged by high tailwater elevations and fail to meet the flow velocity criterion, as discussed in Section 5.2.2.12. In addition, an AWS can be used to provide additional flows to various transition pools in the ladder such as bifurcation or trifurcation pools, multiple entrances, pools in fish trapping facilities, exit control sections, and counting station pools.

#### **5.3.1.1 AWS supply source**

*The source of water for the AWS flow should be of the same quality (e.g., temperature, turbidity, and water chemistry) as the flow in the ladder (i.e., the receiving water).*

The AWS flow is usually routed from the forebay to the ladder via gravity, but water quality may vary from the ladder flow depending on the location of the AWS intake. The AWS flow can also be pumped from the tailrace or delivered via a combination of gravity and pumped sources. Differences in the water sources could cause fish to reject the ladder.

## **5.3.2 Specific Criteria and Guidelines – AWS Fine Trash Racks**

### **5.3.2.1 Bar spacing**

*A fine trash rack should be provided at the AWS intake with clear space between the vertical flat bars of 0.875 inch or less.*

The purpose of an AWS fine trash rack is to stop debris from entering the AWS, which might plug the upstream side of the diffuser panel. Since the normal, clear opening between bars on the diffuser panels is 1 inch (Section 5.3.7), the AWS fine trash rack should be 0.875 inch or less. At sites where Pacific lamprey may be present and diffusers with 0.75-inch clear openings are used (Section 5.3.7), the AWS fine trash rack should have a maximum clear opening of 0.625 inch or less.

### **5.3.2.2 Velocity**

*Maximum velocity through the AWS fine trash rack should be less than 1 ft/s, as calculated by dividing the maximum flow by the submerged area of the fine trash rack.*

### **5.3.2.3 Cleaning consideration**

*The support structure for the fine trash rack should not interfere with cleaning requirements and should provide access for debris raking and removal.*

### **5.3.2.4 Slope**

*The fine trash rack should be installed at a 1H:5V (horizontal:vertical) or flatter slope for ease of cleaning. The fine trash rack design should accommodate maintenance requirements by considering access for personnel, travel clearances for manual or automated raking, and removal of debris.*

### **5.3.2.5 Staff gages and head differential**

*Staff gages should be installed to indicate head differential across the AWS intake fine trash rack and should be located to facilitate observation and in-season cleaning. Head differential across the AWS intake fine trash rack should not exceed 0.3 foot in order to facilitate cleaning, minimize velocity hot spots, and maintain hydraulic efficiency in gravity and pumped systems.*

Staff gages are used for determining whether the head across a trash rack is within criteria or not. Care should be taken when locating staff gages so that they can be easily read by personnel.

### **5.3.2.6 Structural integrity**

*AWS intake fine trash racks should be of sufficient structural integrity to avoid the permanent deformation associated with maximum occlusion.*

### 5.3.3 Specific Criteria and Guidelines – AWS Screens

*In instances where the AWS poses a risk to the passage of juvenile salmonids because of its design involving high head and convoluted flow paths, the AWS intake should be screened to the standards specified in Chapter 8 to prevent juvenile salmonids from entering the AWS.*

Trip gates, pressure relief valves, or other alternate intakes to the AWS may be included in the design to ensure that AWS flow targets are achieved if screen reliability is uncertain under high river flow conditions. Debris and sediment issues may preclude the use of juvenile fish screen criteria for AWS intakes at certain sites. Passage risk through an AWS will be assessed by NMFS on a site-specific basis to determine whether screening of the AWS is warranted and how to provide the highest reliability possible.

### 5.3.4 Specific Criteria and Guidelines – AWS Flow Control

*The AWS should have a flow control device located sufficiently far away from the AWS intake to ensure the flow at the AWS fine trash rack or screen is uniformly distributed. To facilitate cleaning, the flow control system should allow flow to be easily shut off for maintenance and then restarted (and reset) to proper operating conditions.*

The flow control device may consist of a control gate, pump control, turbine intake flow control, or other flow control systems located sufficiently far away from the AWS intake to ensure uniform flow distribution at the AWS fine trash rack for all AWS flows. Flow control is necessary to ensure that the correct quantity of AWS flow is discharged at the appropriate location during a full range of forebay and tailwater levels.

### 5.3.5 Specific Criteria and Guidelines – AWS Excess Energy Dissipation

*Excess energy should be dissipated from AWS flow prior to passage through diffusers.*

Dissipation of excess energy is necessary to minimize surging and induce relatively uniform velocity distribution at the diffusers because surging and non-uniform velocities may cause adult fish jumping and associated injuries or excess migration delay. The introduction of highly turbulent or aerated water will discourage fish from entering or passing through a fishway and possibly result in fish delay or injury (Clay 1995). Examples of methods to dissipate excess AWS flow energy include the following:

- Routing flow into a fishway pool with adequate volume (Section 5.3.6.2)
- Passing AWS flow through a turbine
- Passing AWS flow through a series of valves, weirs, or orifices
- Passing AWS flow through a pipeline with concentric rings or other hydraulic transitions designed to induce head loss

All of these dissipation systems require that AWS flow passes through a baffle system that has a porosity of less than 40% to reduce surging through fishway entrance pool diffusers. Adjustable baffles may be required in some systems to properly balance flow across the diffuser.

Figure 5-3 provides a schematic of a fishway AWS diffuser system showing the components needed, and their shape and arrangement, to control water flow rate and convert high-velocity, high-pressure, non-uniform flow into low-energy uniform flow.

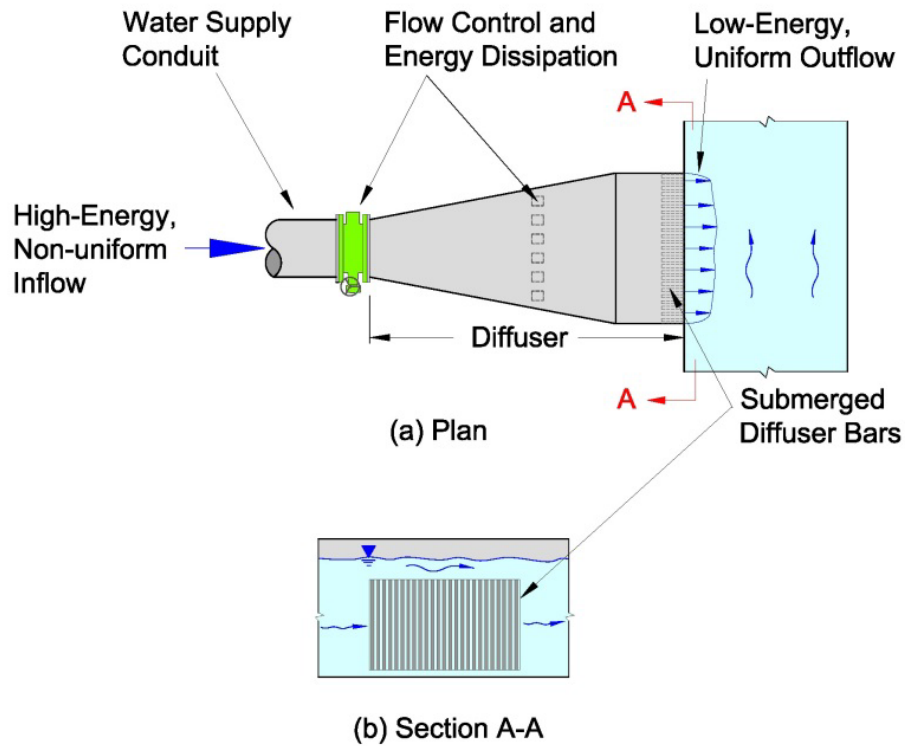

Figure 5-2. Schematic of a fishway AWS diffuser system in plan (a) and section (b) views

### 5.3.5.1 Energy dissipation pool volume

*An energy dissipation pool in an AWS should have a minimum water volume established by the formula shown in Equation 5-1.*

$$V = \frac{(\gamma)(Q)(H)}{16 \text{ ft-lb / ft}^3/\text{s}} \quad (5-1)$$

where:

- $V$  = pool volume in cubic feet (ft<sup>3</sup>)
- $\gamma$  = specific weight of water, 64.2 pounds (lb) per ft<sup>3</sup>
- $Q$  = AWS flow, in ft<sup>3</sup>/s
- $H$  = energy head of pool-to-pool flow, in feet drop into the AWS pool

Note that the pool volumes required for AWS pools are smaller than those required for fishway pools. This is due to the need to provide resting areas in fishway pools and because AWS systems require additional elements (e.g., diffusers and valves) to dissipate energy and are not pathways for upstream fish passage.

### 5.3.6 Specific Criteria and Guidelines – AWS Diffusers

*The spaces between bars of a diffuser should be sized to prevent fish passage and injury (Bell 1991; Bates 1992). For adult salmonid passage, the maximum clear spacing between bars is 1 inch between diffusers bars. At sites where adult Pacific lamprey may be present, diffusers should have a maximum 0.75-inch clear spacing between bars.*

*Wall diffusers should consist of non-corrosive, vertically oriented diffuser panels of vertically oriented flat bar stock. Similarly, floor diffusers should consist of non-corrosive, horizontally oriented diffuser panels of horizontally oriented flat bar stock. Orientation of flat bar stock should maximize the open area of the diffuser panel. If a smaller species or life stage of fish is present, smaller clear spacing between bar stock may be required.*

#### 5.3.6.1 Material

*The bars and picket panels used as part of AWS diffuser systems should be made of aluminum, stainless steel, or epoxy-coated carbon steel. The use of submerged galvanized steel should be minimized or eliminated, especially when used in close proximity to fish (i.e., fishways).*

Galvanized steel is coated with zinc, a metal that can be toxic to fish.

#### 5.3.6.2 Velocity and orientation

*The maximum AWS diffuser velocity should be less than 1 ft/s for wall diffusers and 0.5 ft/s for floor diffusers based on the total submerged diffuser panel area (Bell 1991). Wall diffusers should only be used when the orientation can be designed to assist with guiding fish within the fishway. Diffuser velocities should be nearly uniform, which may require the use of porosity control panels (Section 5.3.6.3). The face of the diffuser panels (i.e., the surface exposed to the fish) should be flush with the wall or floor.*

These criteria are based on *Design of Fishways and Other Fish Facilities* (Clay 1995), which states that 1 ft/s “has been adopted as the best compromise between practicality and efficiency.” These criteria are also based on the results of laboratory studies where spring- and fall-run Chinook salmon and steelhead passage times increased when diffuser flows were added and were progressively longer as floor diffuser velocity increased from 0.25 to 1.25 ft/s (Gauley et al. 1966).

An example of wall diffusers being used to assist in guiding fish is when the diffusers in the entrance pool of a fishway are situated such that fish are naturally lead upstream to the first ladder pool.

When wall diffusers are used in conjunction with a half Ice Harbor-style ladder, the diffuser should be located on the same side as the overflow weir, and the diffuser bars should be oriented horizontally.

### **5.3.6.3 Porosity control baffles**

*Similar to juvenile fish screens, diffusers should include a system of porosity control baffles located just upstream of the diffuser pickets to ensure that average velocities at the face of the diffuser are uniform and can meet criteria (Section 5.3.6.2).*

The purpose of the porosity control panels is to control the amount of flow through the diffuser pickets and create a uniform flow condition at the face of the pickets.

### **5.3.6.4 Debris removal**

*The AWS design should include access for personnel to remove debris from each diffuser unless the AWS intake is required per the criteria listed in Section 5.3.4 to be equipped with a juvenile fish screen (Chapter 8).*

### **5.3.6.5 Edges**

*All flat bar diffuser edges and surfaces exposed to fish should be rounded or ground smooth to the touch, with all edges aligning in a single smooth plane to reduce the potential for contact injury.*

### **5.3.6.6 Lamprey passage**

*At sites where Pacific lamprey are present, horizontal diffusers should not extend the complete width of the floor of the fishway or entrance pool. A solid surface, approximately 1.5 feet wide, should be located along the floor between the lateral sides of the diffuser panels and the base of either wall.*

### **5.3.6.7 Elevation**

*Wall AWS diffusers should be submerged throughout the range of operation (i.e., the top elevation of the wall diffuser should be below the lowest water surface elevation that will occur based on the fishway design).*

This is to prevent water from cascading through the diffuser, which can induce fish to leap at the surface disturbance.

## **5.3.7 Specific Criteria and Guidelines – Bedload Removal Devices**

*At locations where bedload may cause accumulations at the AWS intake, sluice gates or other simple bedload removal devices should be included in the design.*

## **5.4 Transport Channels**

### **5.4.1 Description and Purpose**

A transport channel conveys flows between different sectors of the upstream passage facility, providing a route for fish to pass.

## 5.4.2 Specific Criteria and Guidelines – Transport Channels

### 5.4.2.1 Velocity range

*The transport channel velocities should be between 1.5 and 4 ft/s (Gauley et al. 1966; Bates 1992), including flow velocity over or between fishway weirs inundated by high tailwater (Bell 1991).*

Gauley et al. (1966) reported that Chinook and sockeye salmon and steelhead passage times did not differ significantly between water velocities of 1 and 4 ft/s in an experimental 270-foot-long transportation channel. However, Weaver (1963) reported that Chinook salmon moved progressively slower in a test flume as velocities increased from 2 to 8 ft/s.

### 5.4.2.2 Dimensions

*The transport channels should be a minimum of 5 feet deep and 4 feet wide.*

This is based on providing the narrowest, shallowest flow path that adult fish are known to move through readily while also displaying the least amount of fallback behavior and delay. In addition, this size of channel relates to the goal of keeping water velocities in the transport channel low.

### 5.4.2.3 Lighting

*Ambient natural lighting should be provided in all transport channels, if possible. If ambient (natural) lighting is not available, acceptable artificial lighting should be used.*

*In laboratory tests, fish were presented with the choice of a large entrance (3.9 feet by 3.9 feet) that was dark or a smaller entrance (1.5 feet by 2 feet) that was lighted. Study results corroborate the understanding that fish prefer lighted entrances and channels: 80% of Chinook salmon, 90% of coho salmon, 69% of steelhead, and 86% of sockeye salmon chose the lighted entrance (Bates 1992).*

### 5.4.2.4 Design (general)

*Based on the literature and experiences of fish biologists at many facilities located in the WCR, the following features should be included in the design of transport channels:*

- *The transport channels should be of open channel design (Bell 1991).*
- *Designs should avoid hydraulic transitions or lighting transitions (USFWS 1960; Bell 1991).*
- *Transport channels should not expose fish to any moving parts.*
- *Transport channels should be designed so that there is no standing water in the channel when the system is dewatered.*
- *Transport channels should be free of exposed edges that protrude from channel walls.*



## **5.5 Fish Ladder Design**

### **5.5.1 Description and Purpose**

The purpose of a fish ladder is to convert total project head at the passage barrier into passable increments and provide suitable conditions for fish to hold, rest, and ultimately pass upstream. Nearly all of the energy from the upstream ladder pool is dissipated in the downstream ladder pool volume, resulting in a series of relatively calm pools that migrating fish may use to rest and stage before ascending upstream. The criteria provided in this section have been developed to provide conditions to pass all anadromous salmonid species upstream with minimal delay and injury.

### **5.5.2 Common Types of Fish Ladders**

Fish ladders or fishways, in one form or another, have been around for more than 300 years (Clay 1995). Over time, ladder designs have developed and evolved and have been adapted to meet site-specific conditions. For the purpose of this document, fish ladders are divided into the following two categories:

- Pool-style ladders, including:
  - Vertical slot
  - Pool and weir
  - Weir and orifice
  - Pool and chute
- Roughened (Baffled) chute-style ladders, including:
  - Denil steppass
  - Alaska steppass (ASP)

The following sections present brief discussions of criteria and guidelines for the more common styles of fish ladders.

#### **5.5.2.1 Vertical slot ladder**

The vertical slot configuration is a pool-style of fish ladder (Figures 5-3 through 5-5; Table 5-1). The vertical slot ladder is suitable for passage impediments that have tailrace and forebay water surface elevations that fluctuate within large ranges. The maximum head differential—typically associated with the lowest river flows—establishes the design water surface profile, which usually parallels the fishway floor gradient.

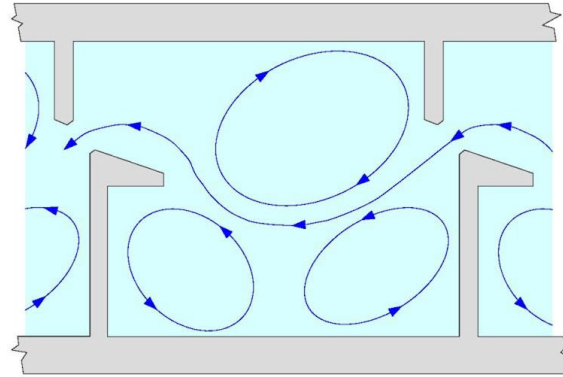

(a) Generalized Flow Path



(b) In actual fishway pools

Figure 5-3. Plan view of a vertical slot ladder showing generalized flow paths



**Figure 5-4. Oblique view of a vertical slot ladder baffle when dewatered**

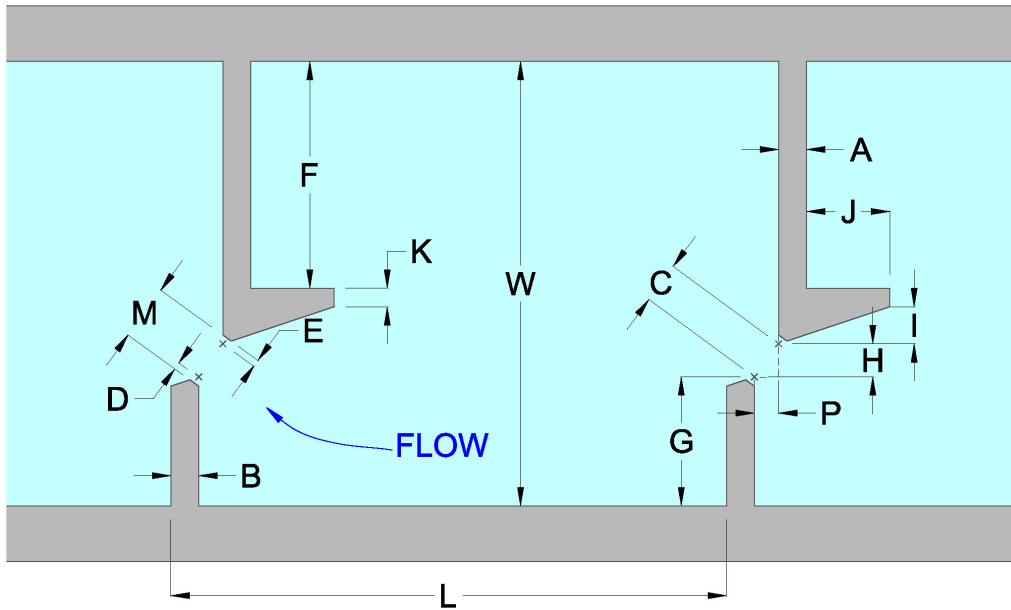

**Figure 5-5. Dimensions of a typical vertical slot ladder pool**

(Note that information for Figure 5-6 is provided in Table 5-1. “D” is the dimension of the layout points used during ladder design and construction (i.e., the framing and the form work for the concrete pours); it determines the chamfer for the slot and the width of the slot; and knowing “D” allows the designer to layout the complex angles used during construction.)

**Table 5-1. Dimensions for vertical slot ladder components measured in feet.**

Symbol	Dimension Nomenclature (Refer to Figure 5-6)			
L	Pool length	10'0"	10'0"	10'0"
W	Pool width	6'0"	8'0"	8'0"
A	Long baffle width <sup>A</sup>	0'6"	0'6"	0'6"
B	Short baffle width <sup>A</sup>	0'6"	0'6"	0'6"
M	Slot width	1'0"	1'0"	1'3"
C	Slot width layout points	0'9"	0'9"	0'9"
D, E	Dimension "C" layout points (separation from baffles)	0'1½"	0'1½"	0'3"
F	Long baffle wall length	3'1"	4'1"	4'1"
G	Short baffle wall length (wall to layout point)	1'¾"	2'¾"	2'¾"
I	Flow deflector width change	0'7"	0'8"	0'7"
J	Flow deflector length	1'3"	1'6"	1'3"
K	Flow deflector upstream width	0'5"	0'4"	0'5"

Note:

A: Short baffle and long baffle widths may need to be increased in certain instances for structural integrity in large fishway installations.

The full-depth vertical slots allow fish passage at any depth (Clay 1995). Fish are assumed to be able to move directly from slot to slot in a straight path, although this has not been verified (Clay 1995). However, hydraulic studies have verified that velocity through the slot is constant throughout the vertical profile (Katopodis 1992). The vertical slot may not be well suited for species that require overflow weirs for passage or that tend to orient to walls such as American shad.

#### **5.5.2.1.1 Vertical slot width and depth**

*For adult anadromous salmonids, slots should never be less than 1 foot in width. If larger Chinook salmon are expected to pass, the minimum slot width is 1.25 feet (Clay 1995). Bell (1991) recommends a minimum slot depth of 3 feet, although they are typically on the order of 5- to 6-feet deep to match the required pool depth.*

The passage corridor typically consists of 1- to 1.25-foot-wide vertical slots between fishway pools. However, narrower slots have been recommended (Clay 1995) and used in applications for other fish species that are smaller than salmon or steelhead. In some situations, wider slots (or two slots per ladder weir) are used if AWS flow is not being added to the ladder.

Vertical slot ladders tend to require more water to operate properly compared with other styles of fishways because of the width and depth of the slot and the head differential between pools. Low sills can be added to the bottom of each slot to reduce the overall amount of flow in

the ladder that is required. However, these sills may block the passage of species that prefer or need to travel along the floor of a ladder.

#### 5.5.2.1.2 *Vertical slot geometry (pool size)*

*Standard, proven design dimensions should be adhered to unless it can be proven through physical hydraulic modeling that changes do not affect the function of the ladder.*

Vertical slot ladders are sensitive to changes in pool geometry (e.g., pool width, length, slope, and slot width; Clay 1995), and initial construction costs are higher than other types of ladders because of the more complex design and concrete placement.

#### 5.5.2.2 **Pool and weir ladder**

The simplest style of fish ladder is the pool and weir ladder (Bell 1991); it is also one of the oldest styles of fish ladder. The pool and weir fish ladder passes the entire, almost constant, fishway flow through successive pools separated by overflow weirs that break the total project head into passable increments (Figure 5-6). This design allows fish to ascend to higher elevations by passing over weirs, and it provides resting zones within each pool. When passing this style of ladder, fish must leap or swim over the weir flow. Pools are sized to allow flow energy to be nearly fully dissipated through turbulence within each receiving pool (Clay 1995).



**Figure 5-6. Examples of pool and weir ladders**

(Note that the orifices in the weir wall on the left-side photo are to drain each of the pools and are not meant for fish passage.)

In contrast to vertical slot ladders, pool and weir ladders require nearly constant water surface elevations in the forebay pool to function properly (Bell 1991; Clay 1995). When the water surface elevation fluctuates outside of the design elevation, too much or too little flow

enters the fishway. This flow fluctuation may affect upstream passage by causing fishway pools to be excessively turbulent or providing insufficient flow. To accommodate forebay fluctuations and maintain a consistent flow in the ladder, pool and weir ladders are often designed with an AWS (Section 5.3) and fishway exit control section (Section 5.7; Bell 1991). To accommodate tailwater fluctuations, pool and weir ladder designs may include an adjustable fishway entrance (i.e., adjustable geometry and attraction flow) and an AWS to provide additional flow to meet the channel velocity criterion (Section 5.4.2.1; Bell 1991).

### 5.5.2.3 Weir and orifice ladder

The weir and orifice fish ladder passes flow from the forebay through successive fishway pools connected by overflow weirs and submerged orifices, which divide the total project head into passable increments (Figures 5-7 and 5-8, Table 5-2; Clay 1995). Weir and orifice ladders are similar to pool and weir ladders in the following ways:

- Weir and orifice ladders require nearly constant water surface elevations in the forebay pool (unless adjustable components are included to accommodate the varying forebay level); water surface elevations outside of the design elevation result in too much or too little flow entering the fishway, which may affect fish passage due to turbulence or insufficient flow.
- Weir and orifice ladders are often designed with an AWS and fishway exit control section (Section 5.7), an adjustable fishway entrance (i.e., adjustable geometry and attraction flow), and an AWS to provide additional low diffusers to meet the transport channel velocity criterion (Section 5.4.2.1).

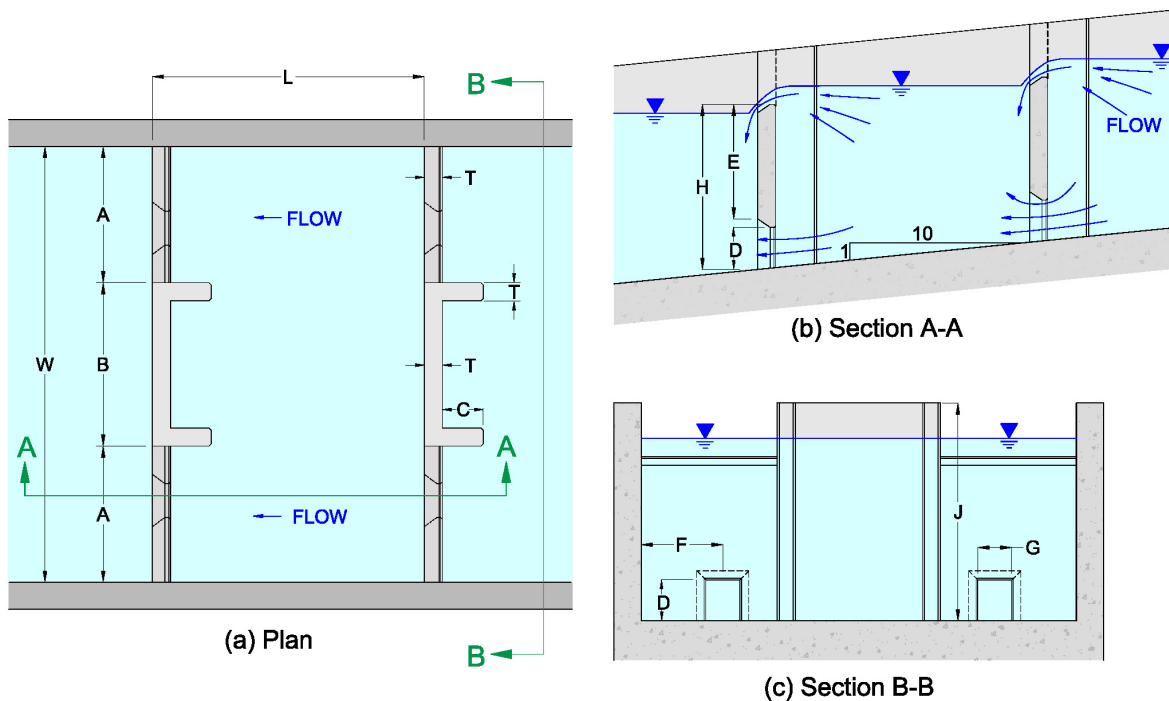

**Figure 5-7. Ice Harbor-style weir and orifice ladder (adapted from Gauley et al. 1966**

(Note that information for Figure 5-7 is provided in Table 5-2.)





(a) Looking downstream

(b) Looking upstream

**Figure 5-8. Overhead views of Ice Harbor-style weir and orifice fish ladders**

**Table 5-2. Dimensions for Ice Harbor fishways measured in feet**

Symbol	Dimension Nomenclature (Refer to Figure 5-8)	Bell 1991	Gauley et al. 1966
L	Pool length	8–20	10
W	Pool width	6–20	16
A	Weir length	1.5–5	5
B	Center baffle width	W/2*	6
C	Flow stabilizer length	NA	1’6”
D	Orifice height	1’6”	1’6”
E	Baffle height above orifice	4’3”	4’6”
F	Wall to orifice center line	NA	3
G	Orifice width	1’3”	1’6”
H	Weir height	6	6
J	Wing baffle height	8	8
T	Weir and baffle thickness	NA	NA

Notes:

\* See “W” in panel (a) of Figure 5-8.

Dimensions listed under Bell (1991) are taken from

[https://www.fs.fed.us/biology/nsacc/fishxing/fplibrary/Bell\\_1991\\_Fisheries\\_handbook\\_of\\_engineering\\_requirements\\_and.pdf](https://www.fs.fed.us/biology/nsacc/fishxing/fplibrary/Bell_1991_Fisheries_handbook_of_engineering_requirements_and.pdf).

Dimensions listed under Gauley et al. 1966 are taken from the report located here:

[https://www.nwfsc.noaa.gov/assets/26/7778\\_08132014\\_135336\\_Gauley.et.al.1966.pdf](https://www.nwfsc.noaa.gov/assets/26/7778_08132014_135336_Gauley.et.al.1966.pdf).

NA: not available

When passing this style of ladder, fish have the choice of leaping or swimming over the weir or swimming through the orifice, and it is NMFS' experience that most salmonids prefer to swim through the orifice. The Ice Harbor ladder is an example of a weir and orifice fish ladder. This ladder design was developed in the 1960s for use at Ice Harbor Dam on the Snake River in Washington by the Bureau of Commercial Fisheries at USACE Fisheries-Engineering Research Laboratory (FERL), which was located at the Bonneville Dam on the Columbia River in Oregon (Figure G-1 in Appendix G). Fish passage research was conducted at FERL from 1955 until it was decommissioned in the 1980s (see Appendix I for a listing of reports of research conducted at the FERL). The research provided basic knowledge of the behavior, abilities, and requirements of fish in fish passage situations (Collins 1976).

Development and testing at FERL resulted in the design of the 1-on-10 slope ladder for Ice Harbor Dam, which was studied in a full-scale section of the ladder consisting of six ladder pools. A prototype ladder was tested during its first year of operation at Ice Harbor Dam. The design is a pool and weir ladder with submerged orifices, flow stabilizers, and a non-overflow section in the middle of each weir (Figures 5-7 and 5-8). See Table 5-2 for typical dimension of this type of fishway. There is a 1-foot rise between pools, and the average water depth under normal operating conditions is 6.5 feet (Gauley et al. 1966). The Ice Harbor-style of ladder includes two rectangular orifices centered on and located directly below each overflow weir. The position and depth of the orifices were found to have a significant effect on the passage of fish through rectangular submerged orifices (Thompson et al. 1967). The orifice and weir combinations are located on each side of the longitudinal centerline of the ladder. Between the two weirs is a slightly higher non-overflow wall with an upstream-projecting flow baffle located at each end. An adaptation for lower flow designs is the half Ice Harbor ladder design, which consists of a weir, an orifice, and a non-overflow wall between fishway pools.

#### **5.5.2.4 Pool and chute ladder**

A pool and chute ladder is a hybrid that operates under varying river flow conditions. This ladder is designed to operate as a pool and weir ladder at low river flows and as a roughened chute-style fishway at higher river flows (Figure 5-9). This ladder is an alternative style of ladder for sites with a low hydraulic drop that must pass a wide range of streamflows with a minimum of flow control features. Placement of stoplogs—a cumbersome and potentially hazardous operation—is required to optimize operation of this ladder. However, once suitable flow regimes are established, the need for additional stoplog placement may not be required. Criteria for this type of ladder design are still evolving, and design proposals will be assessed by NMFS on a site-specific basis. Bates (1992) provides specific criteria and guidelines for this style of ladder where fish have the option of swimming over, or leaping the overflow weir, or swimming through the orifice. The lateral slope of the weirs presents fish with flow conditions that range from plunging flow near the edges to streaming flow towards the center of the ladder.





**Figure 5-9. Pool and chute ladder dewatered (at left) and watered (at right)**

#### **5.5.2.5 Half Ice Harbor and half-pool and chute ladders**

The flow rate available to pass through a fishway at small projects is often too low to take advantage of the benefits of the standard Ice Harbor or pool and chute ladder designs. In these situations, it is possible to design and construct weirs shaped as one-half of an Ice Harbor-style weir and orifice ladder or one-half of a pool and chute-style ladder (Figure 5-10). These designs share the same advantages and disadvantages as their full-sized counterparts and should meet all of the design criteria for each type of full-sized ladder. The hydraulic design process used for half-ladders is analogous to the design process used for full-sized ladders.



**Figure 5-10. Half ladder designs for projects with reduced available fishway flows**

(Note: panel on left is a half-Ice Harbor ladder weir and orifice design; panel on right is a half-pool and chute ladder with weir design.)

### **5.5.3 Specific Criteria and Guidelines – Fish Ladder Design**

#### **5.5.3.1 Hydraulic drop**

*The maximum hydraulic drop between fish ladder pools should be 1 foot or less (Bell 1991; Clay 1995). Where pink or chum salmon are present, the maximum hydraulic drop between pools should be 0.75 foot or less (Bates 1992; Clay 1995).*

#### **5.5.3.2 Flow depth**

*Fishway overflow weirs should be designed to provide at least 1 foot ( $\pm 0.1$  foot) of flow depth over the weir crest (Clay 1995; WDFW 2000).*

The depth should be indicated by locating a single staff gage in an observable, hydraulically stable location that is representative of flow depth throughout the fishway. The zero reading of the gage should be at the overflow weir crest elevation.

##### **5.5.3.2.1 Streaming flow**

*Some fish species will not leap or are poor leapers and will refuse to pass or become delayed by plunging flow conditions in a ladder. They may also refuse to pass through the orifices in a ladder (e.g., all shad species). For those species, streaming flow should be created*

*between ladder pools to provide acceptable passage conditions. When pink or chum salmon are present, the upstream weir crest should be submerged by at least 0.5 foot by the downstream water surface level (Bates 1992). Where American shad are present, the upstream weir crest should be submerged by at least 0.3 foot by the downstream water surface level.*

Streaming flow occurs when the weir is backwatered by the downstream weir (Bates 1992; Katapodis 1992). The transition between plunging flow and streaming flow is hydraulically unstable and should be avoided according to Bell (1991) and Bates (1992) because passage can be delayed when flow is in this transition. Hydraulic instability occurs in the transition regime between the upper range of plunging flow and the lower range of streaming flow. The instability can also cause large oscillations that are transmitted throughout the fishway because energy is not dissipated in each pool of the fishway, which makes the streaming flow jet difficult to manage. For these reasons, streaming flow in a fishway should be used cautiously (Bates 1992).

Submerging the upstream weir crest by 0.3 foot is based on experience with adjusting ladder flows at Columbia River dams to pass American shad. In addition, Larinier and Travade (2002) state that a head of around 1.3 feet and streaming flow in an Ice Harbor-style ladder are needed for shad passage. Rideout et al. (1985) report substantial improvements in American shad passage at the Turners Falls dam fishway in Massachusetts when flow over weir crests was changed from plunging to streaming.

#### **5.5.3.3 Pool dimensions**

*In general, pool dimensions should be a minimum of 8 feet long (upstream to downstream), 6 feet wide, and 5 feet deep. However, specific ladder designs may require pool dimensions that are different from the minimums specified in this criterion, depending on site conditions and ladder flows (see Clay 1995).*

*For small stream ladders, Bell (1991) provides minimum dimensions for some pool and weir fishway designs. The minimum pool should not be less than 6 feet long, 3 feet deep, and 4 feet wide. It is recommended that the fishway slope not exceed 1:8. For pools less than 8 feet in length, the drop between pools should be reduced proportionally. To allow for the proper dissipation of the orifice flow, the pool dimensions for a pool and orifice-style ladder should not be reduced (Clay 1995).*

*Ladder pools should be designed so that there is no standing water in the pools when the system is dewatered. The floors of the ladder should be sloped from the sides to the floor orifice to encourage fish to move downstream during salvage operations conducted when a ladder is dewatered for maintenance.*

#### **5.5.3.4 Turning pools**

*Turning pools (i.e., pools where the fishway direction changes more than 90 degrees) should be at least double the length of a standard fishway pool, as measured along the centerline of the fishway flow path. The orientation of the upstream weir to the downstream weir should be such that energy from flow over the upstream weir does not affect the hydraulic conditions at the downstream weir.*

### 5.5.3.5 Pool volume

*The pool volume within the fishway should provide sufficient volume (i.e., hydraulic capacity) to absorb and dissipate the pool-to-pool energy and accommodate the maximum daily run of fish (i.e., fish capacity; Appendix H).*

*Generally, the volume required to provide adequate hydraulic capacity governs pool sizing (Bell 1991; Bates 1992). To provide adequate hydraulic capacity, the fishway pools should be a minimum volume (of water) based on Equation 5-2.*

$$V = \frac{(\gamma)(Q)(H)}{4 \text{ ft-lb / ft}^3/\text{s}} \quad (5-2)$$

where:

- $V$  = pool volume in ft<sup>3</sup>
- $\gamma$  = specific weight of water, 64.2 lb per ft<sup>3</sup>
- $Q$  = specific weight flow, in ft<sup>3</sup>/s
- $H$  = energy head of pool-to-pool flow, in feet

*This pool volume should be provided under every expected design flow condition, with the entire pool volume having active flow and contributing to energy dissipation.*

If large numbers of fish are expected to pass the fish ladder in a relatively short amount of time, overcrowding can occur, leading to delay. Delay in passage is minimized by providing ample volume to accommodate the peak of the run without overcrowding (Clay 1995). Therefore, it may be necessary to increase the individual pool volume to accommodate the peak run of fish. See Appendix H for sizing a fish ladder based upon run size.

### 5.5.3.6 Freeboard

*The freeboard of the ladder pools should be at least 3 feet at high design flow.*

### 5.5.3.7 Orifice dimensions

*At sites where large salmonids are expected, the minimum dimensions of the orifice should be 18 inches high by 15 inches wide (Bell 1991), based on the Ice Harbor ladder design dimensions (Section 5.5.3.3).*

*The minimum dimensions of orifices where large salmonids are not expected should be at least 15 inches high by 12 inches wide.*

*The top and sides of the orifice should be chamfered 0.75 inch on the upstream side and chamfered 1.5 inches on the downstream side of the orifice to provide the most stable flow (Bates 1992).*

*For sites where Pacific lamprey are present, the floor of the fishway should provide a continuous, uninterrupted surface through the orifice. USACE (Portland District) has developed and installed an orifice with rounded edges to facilitate Pacific lamprey passage.*

The primary concern with smaller orifices is the increased risk of plugging by debris (WDFW 2000).

#### **5.5.3.8 Lighting**

*Ambient lighting should be provided throughout the fishway, and abrupt lighting changes should be avoided (Bell 1991). In enclosed systems, such as transport tunnels, provisions for artificial lighting should be included. In cases where artificial lighting is required, lighting in the blue-green spectral range should be provided. Artificial lighting should be designed to operate under all environmental conditions at the installation.*

These lighting criteria are based in part on laboratory studies where a majority of Chinook and sockeye salmon and steelhead entered the lighted orifice when given a choice between a dark experimental orifice and a lighted control orifice where head was equal between the two orifices (Weaver et al. 1976).

#### **5.5.3.9 Change in flow direction**

*At locations where the flow changes direction more than 60 degrees, 45-degree vertical miters (minimum 20 inches wide) or a 2-foot minimum, vertical radius of curvature should be included in the design of the outside corners of fishway pools (Bell 1991).*

Bell reports that “Fish accumulate when pool hydraulic patterns are altered. If the design includes turn pools, fish will accumulate at that point. Square corners, particularly in turn pools, should be avoided as fish jump at the upwelling so created” (1991). Depending upon the pool configuration, size of the turning pool, and amount and velocity of the flow in the ladder, larger radii of curvatures may be necessary.

## **5.6 Counting Stations and Windows**

### **5.6.1 Description and Purpose**

Counting stations provide a location and facility to observe and enumerate fish utilizing the fish passage facility. Although not always required, a typical counting station includes a video camera or fish counting technician, crowder, and counting window (Bell 1991). Counting stations are often included in a fish ladder design to allow fishery managers to assess fish population status, observe fish size and condition, and conduct scientific research.

#### **5.6.1.1 Operation**

*Counting stations should not interfere with the normal operation of the ladder and should not create excessive fish passage delay.*

A decision to include a counting station as part of the ladder design should be carefully considered. Regardless of how well the counting station is designed, oftentimes fish hold and delay at counting stations because of conditions that change the facility such as crowding, lighting, and hydraulics. Instead of a counting station, other means of enumeration may be acceptable, including the use of submerged cameras and their associated lighting, adult PIT-tag detectors, and orifice counting tubes.

## **5.6.2 Specific Criteria and Guidelines – Counting Stations**

### **5.6.2.1 Location**

*Counting stations should be located in a hydraulically stable, low velocity (i.e., around 1.5 ft/s), and accessible area of the upstream passage facility.*

### **5.6.2.2 Downstream and upstream pools**

*The pool downstream of the counting station should extend at least two standard fishway pool lengths from the downstream end of the picket leads. The pool upstream of the counting station should extend at least one standard fishway pool length from the upstream end of the picket leads. Both pools should be straight and in line with the counting station (Bell 1991).*

## **5.6.3 Specific Criteria and Guidelines – Counting Windows**

### **5.6.3.1 Design and material**

*The counting window should be designed such that cleaning of the window can be accomplished completely, conveniently, and at a frequency that ensures window visibility will be maintained and accurate counting can be accomplished. The counting window material should be abrasion-resistant to accommodate frequent cleaning.*

### **5.6.3.2 Orientation**

*Counting windows should be vertically oriented.*

### **5.6.3.3 Sill**

*The counting window sill should be positioned to allow full viewing of the fish passage slot (from floor to water surface).*

### **5.6.3.4 Lighting**

*The counting window design should include sufficient indirect, artificial lighting to provide satisfactory fish identification at all hours of operation and without causing passage delay.*

### **5.6.3.5 Dimensions**

*The minimum observable length of the counting window in the upstream-to-downstream flow direction should be 5 feet, and the minimum height (depth) should be full water depth.*

### **5.6.3.6 Counting window slot width**

*The width of the counting station slot (the area between the counting window and the vertical surface at the back of the slot) should be at least 18 inches. The design should include an adjustable crowder to move fish closer to the counting window (but not closer than 18 inches) to allow fish counting under turbid water conditions. The counting window slot width should be maximized as water clarity allows and when not actively counting fish.*

### **5.6.3.7 Picket lead**

*A downstream picket lead should be included in the design to guide fish into the counting window slot, and it should be oriented at a deflection angle of 45 degrees relative to the direction of fishway flow. An upstream picket lead oriented at a deflection angle of 45 degrees to the flow direction should also be provided. Picket orientation, picket clearance, and maximum allowable velocity should conform to specifications for diffusers (Section 5.3.7).*

*Combined maximum head differential through both sets of pickets should be less than 0.3 foot. Both upstream and downstream picket leads should be equipped with witness marks to verify correct position when picket leads are installed in the fishway. A 1-foot-square opening should be provided in the upstream picket lead to allow smaller fish that pass through the downstream picket lead to escape the area between the two picket leads.*

Picket leads may comprise flat stock bars oriented parallel to flow or other cross-sectional shapes, if approved by NMFS.

### **5.6.3.8 Transition ramps**

*If the counting window requires a false floor to force fish to swim higher in the water column to be more easily identified, then transition ramps should be included in a counting station design. The ramps should smoothly transition from the floor of the counting station pool to the false floor at the counting window and then back to the counting station floor.*

These ramps provide gradual transitions between walls, floors, and the false floor in the counting window slot. The purpose is to minimize flow separations created by head loss that may impede fish passage and induce fallback behavior at the counting window. In situations where space is available, the transitions should be more gradual than 1:8, and where space is confined, a 1:4 transition should be used.

### **5.6.3.9 Water surface through the counting slot**

*A free water surface should exist over the length of the counting window.*

## **5.7 Fishway Exit Control**

### **5.7.1 Description and Purpose**

This section describes and provides criteria for a ladder exit control channel for fish to egress the fishway and enter the forebay of a dam to continue upstream migration. The exit



control channel may include the following features: add-in auxiliary water valves and diffusers, exit pools with varied flow, exit channels, a coarse trash rack that keeps large debris out of the ladder but allows fish to pass through the trash rack and exit the ladder, and fine trash racks and control gates on AWS systems. The exit control section of the ladder also attenuates fluctuations in forebay water surface elevation, thus maintaining hydraulic conditions suitable for fish passage in the ladder pools. Other functions that should be incorporated into the design of the exit control section include minimizing the entrainment of debris and sediment into the fish ladder. Different types of ladder designs (Section 5.5) require specific fish ladder exit design details unique to each type of ladder.

## **5.7.2 Specific Criteria and Guidelines – Fishway Exit Control**

### **5.7.2.1 Hydraulic drop**

*The exit control section hydraulic drop per pool should range from 0.25 to 1 foot.*

### **5.7.2.2 Length**

*The length of the exit channel upstream of the exit control section should be a minimum of two standard ladder pools.*

### **5.7.2.3 Design requirements**

*Exit section design should utilize the requirements for AWS diffusers, channel geometry, and energy dissipation as specified in Sections 5.3, 5.4, and 5.5.*

### **5.7.2.4 Closure gates**

*Any closure gate that is incorporated into the exit control section should be operated either in the fully opened or closed position (i.e., the gates cannot be partially open to regulate flow).*

### **5.7.2.5 Location**

*In most cases, the ladder exit should be located along a shoreline, in a velocity zone of less than 4 ft/s, and sufficiently far enough upstream of a spillway, sluiceway, or powerhouse to minimize the risk of fish non-volitionally falling back through these routes (Clay 1995).*

The distance the exit needs to be upstream of these hazards depends on bathymetry near the dam spillway or crest and associated longitudinal river velocities (Bell 1991).

### **5.7.2.6 Public access**

*Public access near the ladder exit should be prohibited.*



## **5.8 Fishway Exit Sediment and Debris Management**

### **5.8.1 Description and Purpose**

As stated in Section 5.7.1, the design of the ladder exit should strive to minimize the entrainment of debris and sediment into the fish ladder. Floating and submerged debris can become lodged in ladder orifices or on weir crests, alter hydraulic conditions in these fish passage routes, and impact fish behavior and passage rates. Similarly, sediment transported into the fishway can deposit in low-velocity areas, alter hydraulic conditions, and impact fish passage. Removing debris and sediment from ladders can be difficult and costly. Therefore, preventing debris and sediment from entering the ladder from the forebay should be a goal of the ladder exit design.

#### **5.8.1.1 Coarse trash rack**

*For facilities where maintenance is frequently required and provided, coarse trash racks should be included at the fishway exit to minimize the entrainment of debris into the fishway (Figure 5-9; Bell 1991).*

### **5.8.2 Specific Criteria and Guidelines – Coarse Trash Rack**

#### **5.8.2.1 Velocity**

*The velocity through the gross area of a clean coarse trash rack should be less than 1.5 ft/s to reduce debris accumulation and thus facilitate cleaning of the racks regularly (Bates 1992).*

Bell (1991) indicated there is no evidence of fish refusing to pass through trash racks at velocities normal to the trash rack of 2 ft/s or less.

#### **5.8.2.2 Depth**

*The depth of flow through a coarse trash rack should be equal to the pool depth in the ladder exit channel.*

#### **5.8.2.3 Maintenance**

*At locations where manual cleaning is anticipated, the coarse trash rack should be installed at 1:5 slope (or flatter) for ease of cleaning (Bates 1992). The coarse trash rack design should allow for easy maintenance and provide access for personnel, travel clearances for manual or automated trash raking, and the removal of debris.*

#### **5.8.2.4 Bar spacing**

*The coarse trash rack on the ladder exit should have a minimum clear space between vertical flat bars of 10 inches if Chinook salmon are present, and 8 inches for all other species and instances. Lateral support bar spacing should be a minimum of 24 inches and should be sufficiently set back from the face of the coarse trash rack to allow trash rake tines to fully*

*penetrate the rack for effective debris removal. Coarse trash racks should extend to the appropriate elevation above water to allow debris raked from the trash racks to be easily removed.*

Bell (1991) recommends that the clear openings of a trash rack be adapted to the width of the largest fish to be passed, which is usually 12 inches for large salmon. Figure 5-11 shows an example of a sloping coarse trash rack on the exit channel of a small fishway.



**Figure 5-11. Sloping coarse trash rack on a fishway exit channel**

#### **5.8.2.5 Orientation**

*The fishway exit coarse trash rack should be oriented at a deflection angle greater than 45 degrees relative to the direction of river flow.*

### **5.8.3 Specific Criteria and Guidelines – Debris and Sediment**

#### **5.8.3.1 Coarse floating debris**

*Debris booms, curtain walls, or other provisions should be included in the design of a fishway if coarse floating debris is expected.*

#### **5.8.3.2 Debris accumulation**

*If debris accumulation is expected to be high, the fishway design should include an automated mechanical debris removal system. If debris accumulation potential is unknown, the*

*design should anticipate the need for debris removal in the future and include features to allow an automated mechanical debris removal system to be retrofitted to the design.*

### **5.8.3.3 Sediment entrainment and accumulation**

*The fishway exit should be designed to minimize sediment entrainment into the fishway and sediment and debris accumulation at the exit under normal operations.*

## **5.9 Roughened (Baffled) Chute Fishways**

### **5.9.1 Description and Purpose**

This section discusses the baffled chute, which is another general type of fish passage system. It consists of a hydraulically roughened flume that has nearly continuous energy dissipation throughout its length.

### **5.9.2 Specific Criteria and Guidelines – Baffled Chutes**

The baffled chute fishway utilizes a relatively steep, narrow flume with internal roughness elements that generate lower water velocities that allow the fish to swim through the fishway. Denil and ASP fishways are examples of baffled chute fishways that share a similar design philosophy. Baffled chute fishways are designed to operate with less flow and at steeper slopes than traditional ladders.

#### **5.9.2.1 Uses**

*Denil and ASP fishways should not be used as the primary route of passage at permanent fishway installations in the WCR.*

Baffle chute fishways are not considered a substitute for a permanent style of ladder (e.g., a pool and weir ladder) because of their tendency to collect debris and their limited operating range. Denil and ASP fishways are primarily used at sites where the fishway can be closely monitored and inspected daily. This includes off-ladder fish traps, temporary fishways used during construction of permanent passage facilities, and fishways operated temporarily each year to collect hatchery broodstock. Baffle chute fishways should not be used at locations or in situations where the downstream passage of adults or juvenile salmonids occurs.

#### **5.9.2.2 Debris**

*Denil and ASP fishways should not be used in areas where even minor amounts of debris are expected (Bell 1991).*

Debris accumulation in any fishway, in combination with turbulent flow, may injure fish or render the fishway impassable. Because of their internal baffle geometry and narrow flow paths, baffle chute fishways are especially susceptible to debris accumulation, creating a blockage to passage.

### 5.9.2.3 Design

Denil and ASP fishways are designed with a sloped channel that has a constant discharge for a given normal depth, chute gradient, and baffle configuration (Figure 5-12). Energy is dissipated consistently throughout the length of the fishway via channel roughness and results in an average velocity compatible with the swimming ability of adult salmonids. The passage corridor consists of a chute flow between and through the baffles. A wide range of flows are possible for Denil fishways depending on fishway size, slope, and water depth (Bates 1992).

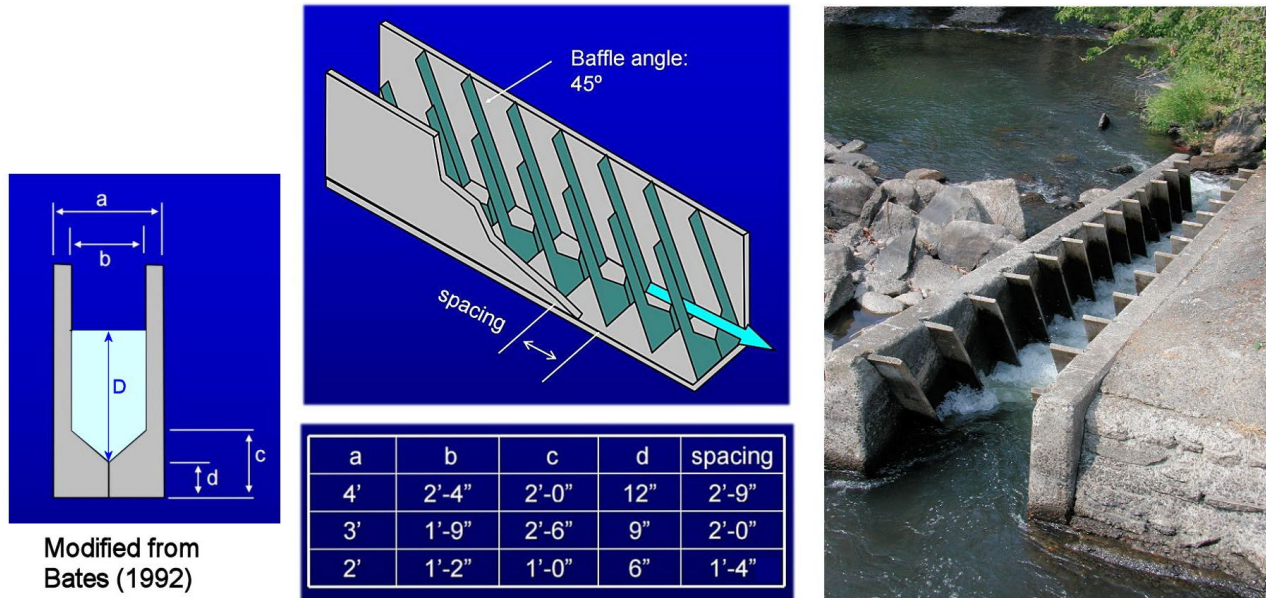

Figure 5-12. Drawings, dimensions, and a photo of a Denil fishway

#### 5.9.2.3.1 Specific design information – Denil fishways

The standard dimensions shown in Figure 5-12 and the following design information for Denil fishways is taken from Bates (1992):

- *NMFS recommends a maximum slope of 20%.*
  - The normal slope for a Denil-style fishway is 17% (Bell 1991), though they have been used at slopes up to 25% (Bates 1992).
- *Discharge through Denil fishways can be calculated using Equation 5-3 (Bates 1992).*

$$Q = 5.73D^2\sqrt{bS} \quad (5-3)$$

where:

- $Q$  = ladder flow, in ft<sup>3</sup>/s
- $D$  = depth (feet) of flow above the vee baffle
- $b$  = clear opening in the baffle (feet)
- $S$  = slope (feet/feet)



- *The average chute design velocity should be less than 5 ft/s (Bell 1991).*
  - The most common size of Denil fishway used is the 4-foot-wide flume (Bates 1992).
- *Flow control is important though not as critical for a Denil fishway as for a weir and pool ladder. The forebay should be maintained within several feet to maintain good passage conditions in a Denil fishway.*
  - According to the velocity profiles developed by Rajaratnam and Katopodis (1984), centerline velocities increase towards the water surface in Denil fishways where the ratio of flow depth to width ( $D/b$  in Figure 5-13) is more than 3. The height of the Denil fishway is not limited; additional height adds attraction flow and operating range without additional passage capacity because of the higher velocities in the upper part of the fishway (Bates 1992).
- *Minimum depth in a Denil fishway should be 2 feet, and depth should be consistent throughout the fishway for all flows.*
  - Bates (1992) reports that Denil fishways are typically constructed with depths from 4 to 8 feet.
- *The standard length is 30 feet (Bell 1991).*
- *Denil fishways can be constructed out of plywood, steel, or concrete with steel or plywood baffles.*

#### 5.9.2.3.2 *Specific design information – Alaska steeppass fishways*

The ASP fishway is a specially designed baffle chute fishway developed for use in a variety of locations in Alaska (Figure 5-14; Ziemer 1962). It is typically constructed in sections that can be bolted together on site, making the system portable.



(a) Downstream end.



(b) Upstream end.

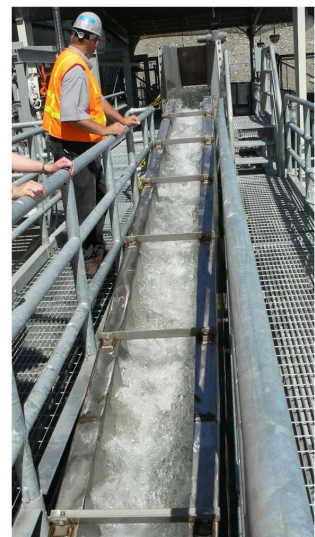

(c) In operation.

**Figure 5-13. Examples of ASP fishways**

The following design information for ASP fishways is taken from Rajaratnam and Katopodis (1984):

- *Discharge through the ASP fishway can be calculated as shown in Equation 5-4:*

$$Q = 1.12S^{0.5} D^{1.55} g^{0.5} \quad (5-4)$$

where:

- $Q$  = flow (ft<sup>3</sup>/s)
- $S$  = slope (ft/ft)
- $D$  = depth (feet) of flow above the floor vane
- $g$  = gravitational acceleration (32.2 ft/s<sup>2</sup>)

Most of the following design information on ASP fishways is taken from Bates (1992), and standard ASP fishway dimensions are shown in Figure 5-14.

- *NMFS recommends a maximum slope of 28%.*
  - The normal slope is about 25%, but ASP fishways have been tested and used up to a slope of 33% (Bates 1992).
- *The average chute design velocity should be less than 5 ft/s.*
- *Flow control is very important for properly functioning ASP fishways. The forebay water surface cannot vary more than 1 foot without creating passage difficulties, and the tailwater should be maintained within this same range to prevent a plunging flow or backwatered condition from forming. Backwatering the entrance results in reduced entrance velocity and fish attraction (Bates 1992).*
  - For example, Slatick (1975) found that the median passage time for salmon increased fourfold, and 25% fewer salmon entered the fishway when the downstream end was submerged by 2.5 feet.
- *Minimum depth in an ASP fishway is 1.2 feet.*
- *The standard length of each unit is 10 feet. Individual units can be bolted together to create lengths of 20 to 30 feet.*
- *ASP fishways are usually constructed of heavy gauge aluminum.*

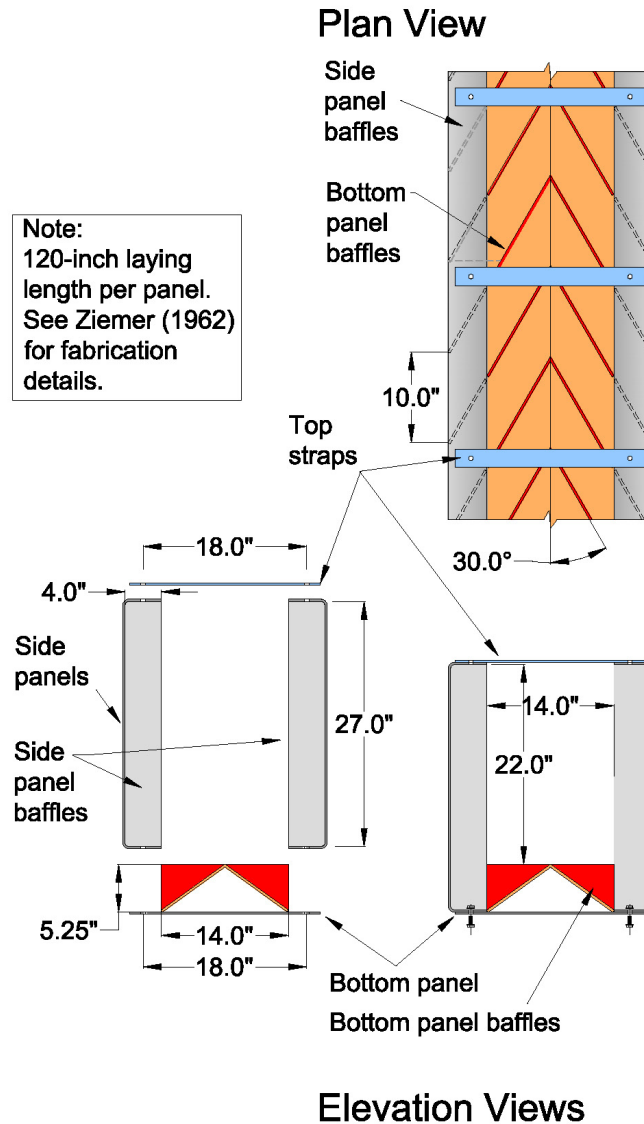

Figure 5-14. Plan and elevation views of a typical ASP fishway

### 5.9.2.3.3 Special considerations for Denil and Alaska steppass fishways

The following unique aspects of Denil or ASP fishways must be carefully considered: intermediate resting pools, minimum resting pool volume, and exit locations.

- Intermediate resting pools:

*If the Denil or ASP fishway is long, intermediate resting pools should be included in the design. Resting pools (where water velocities are less than 1 ft/s) should be provided for Denil fishways longer than 30 feet in length (Bell 1991); resting pool size should be based on minimum pool size or EDF (energy dissipation factor) calculations. These guidelines also apply to ASP fishways longer than 30 feet in length.*

Typically, there are no resting locations within a given length of Denil or ASP fishway. Once a fish starts to ascend a length of an ASP or Denil fishway, it must pass all the way upstream and exit the fishway or risk injury when falling back downstream. Therefore, if the Denil or ASP fishway is long, intermediate resting pools should be included in the design. Clay (1995) recommends that resting pools be provided for every 12 feet of height ascended and that average velocity in the resting pool should not exceed 1 ft/s. NMFS recommends that the designer size the resting pool based on the minimum pool size necessary to achieve either an average velocity of 1 ft/s or an adequate pool size based on the expected run size, if known (Appendix H), or on the EDF formula for pool volume (Equation 5-5), whichever is larger.

- Minimum resting pool volume:

*The minimum volume of the resting pool is calculated as shown in Equation 5-5, which is similar to Equation 5-2 in Section 5.5.3.5 except that the volume required is increased by a factor of 2 since this equation is for a resting pool.*

$$V = (\gamma)(Q) \left( \frac{v^2}{2g} \right) / \left\{ \left( 2ft \frac{lbs}{s} \right) / ft^3 \right\} \quad (5-5)$$

where:

$V$	= volume, in $ft^3$
$\gamma$	= specific weight of water, 62.4 lb per $ft^3$
$Q$	= Denil or ASP flow, in $ft^3/s$
$v$	= velocity of pool-to-pool flow, in $ft/s$
$g$	= gravitational acceleration ( $32.2 ft/s^2$ )

Blackett (1987) conducted experimental modifications to an ASP fishway at a 10-meter-high falls to improve sockeye salmon entry and passage. Sockeye salmon passage was equivalent between an ASP fishway of approximately 200 feet in length with no resting pools and an adjoining ASP fishway where three resting pools were incorporated into the design—although significant year-to-year differences in passage occurred amongst each ASP fishway. However, resting pools were beneficial for holding slower or descending salmon without blocking the passage of other salmon. Also, sockeye salmon passage was greater in the original ASP fishway with three resting pools than in another ASP fishway tested that contained a single resting pool.

- Exit locations:

*Denil and ASP fishway exits should be located to minimize the potential for fish to fallback over the barrier.*

## 5.10 Nature-Like Fishways

The nature-like fishway is a fishway type characterized by its use of natural materials (such as rocks and boulders) and incorporation of natural riverine characteristics in its construction and design (Katopodis et al. 2001; Wildman et al. 2003). Nature-like fishway design simulates the hydraulic conditions of natural channels, natural passage windows, and migration timing for target fish species. The resulting project should provide natural hydraulic conditions



for target species (mimicking the geomorphic form and complexity found in natural channels the target species inhabit).

Nature-like fishways are thought to facilitate the passage of a wide assemblage of fish and aquatic species, sometimes purported to provide better passage than traditional methods (fish ladders). However, Castro-Santos (2011) concluded that nature-like fishway designs evaluated in his study were not superior to traditional fish ladders for the 23 fish species from the northeastern United States (of those that were evaluated). More recently, Landsman et al. (2018) compared the passage of salmonid and non-salmonid species at nature-like fishway and pool-and-weir fishways in eastern Canada and reported similar results. Nature-like fishways have been observed to pass anadromous and resident salmonids with varying degrees of success at projects of varying hydraulic complexity (Aarestrup et al. 2003; Calles and Greenberg 2005, 2009; Dodd et al. 2017).

At the project-scale, design variables related to nature-like fishways are nearly synonymous with more traditional fish ladder designs typically used at these same locations (such as a vertical slot or ice harbor). The main difference being that nature-like fishways are constructed using natural materials, not concrete. Like any other fishway, if the design variables between the tailrace and the forebay are improperly designed, the result may be adverse passage effects to the project. All project-scale passage variables should be properly analyzed, accounted for, and work together to provide safe, timely, and effective upstream passage for salmonids and other target species (the same expectation as had for any other style of fishway).

### **5.10.1 Experimental Applications**

Nature-like concepts and methods are sometimes used in conjunction with more traditional fishway designs. When combining nature-like methods with traditional methods many of the passage assumptions and anticipated hydraulic conditions associated with traditional fishways do not hold, or are hard to predict. Combined designs are classified by NMFS as experimental. Experimental designs are addressed in Section 1.5 and should be vetted using the guidelines contained in Appendix C.

### **5.10.2 Design Methods**

Nature-like fishways are intended to simulate passage conditions of a natural channel. Like natural channels, there is a high degree of hydraulic variability within the fishway. This high variability makes recommending a universal design approach challenging. The following guidelines will help designers better understand critical components of nature-like fishway design, regardless of the engineering methods and approaches implemented.

Nature-like fishway designs may simulate the form and roughness of a reference reach selected as a design template from a natural channel, or the design may rely on hydraulic analysis and physical modeling, or both. The following sources provide additional information on the hydraulic and geomorphic concepts and potential design methods used in nature-like fishway design: Acharya et al. 2000; Keils et al. 2000; Katopodis et al. 2001; Courtice et al. 2016.

### 5.10.3 Specific Criteria and Guidelines

The criteria contained in this section apply primarily to fish passage projects where the fishway is designed to provide passage around a dam or diversion.

#### 5.10.3.1 Maximum average channel velocity

*Maximum average channel velocity at the 5% exceedance flow should be no greater than 5 ft/s, regardless of channel slope. The relationship between channel roughness and channel slope should be carefully engineered to ensure this criterion is not exceeded.*

Barnard (2013) indicates that at the 10% exceedance flow, high gradient streams in Washington State exhibit similar average channel velocities, regardless of channel slope, on the order of 4 ft/s. The velocity criterion in the section is presented to help designers express a more realistic relationship between channel slope and roughness in nature-like fishway designs. When channel slope and roughness have the proper relationship to maintain a 5 ft/s average channel velocity at the 5% exceedance flow, energy dissipation and turbulence are much more likely to be within the range observed in natural high gradient streams of similar slope and roughness. This criterion also simplifies and improves design and monitoring by providing a simple value to compare against hydraulic models and field measurements. An in-depth discussion on turbulence in higher gradient natural channels is contained in CH 6 of Barnard (2013).

The origin of the 4ft/s criterion used the 10% exceedance flow to back calculate EDF in high gradient natural channels. When using a 5% exceedance flow it seems reasonable to increase the maximum average channel velocity to 5 ft/s. When using a 1% exceedance flow, it seems reasonable to use a maximum average channel velocity of 6 ft/s. These assumptions are supported by data from Castro and Jackson (2001) which indicates the average bankfull channel velocity in the Pacific Northwest can be well represented as an average of 6 ft/s. Work by Love and Lang (2014) reported that annual exceedance values associated with a discharge equal to 50% of the 2-year return interval ranged between 0.2% and 1.8%. Annual exceedance flows between 10% and 1% exceedance are likely well represented by a range of average channel velocities between 4ft/s and 6ft/s.

#### 5.10.3.2 Pool depth

*If drop structures are used in the fishway, minimum pool depth should be 4 feet in the receiving pool of each drop structure.*

#### 5.10.3.3 Maximum hydraulic drop

*Maximum hydraulic drop is 1 foot for adult salmonids and 0.5 foot for juvenile salmonids.*

#### 5.10.3.4 Maximum fishway slope

*Maximum fishway slope is 5% for all salmonid species.*

### 5.10.3.5 Channel stability

*Beds and banks should be designed to be immobile at all anticipated fishway discharges.*

### 5.10.3.6 Channel roughness

*Simulated or modeled roughness values should be physically expressed in the post-construction roughness of the channel design. Actual fishway roughness should produce a maximum 5 ft/s average velocity at the high fish passage design flow. Designers should provide a summary discussion of how modeled roughness will be translated and transformed into actual project roughness.*

Modeling requires the use of roughness values to estimate the effects of boundary roughness on water depth and velocity in channel design. NMFS has observed there can be large discrepancies between modeled roughness values and the actual roughness physical expressed in the design post-construction. These discrepancies are typically expressed as higher velocities, increased turbulence, unanticipated scour and erosion, and a fewer holding and resting areas than were expected. Individually and in aggregate these issues can adversely affect fish passage. It is expected that documentation of the methods, assumptions, and specifications used to detail and explain the roughness design process will result in fewer projects failing to meet passage requirements.

Channel roughness providing the bulk of fish passage benefits are best described and specified comparing the size of the elements to the depth of water at the high fish passage design flow. Large roughness elements will possess an exposed dimension above the thalweg that is analogous to the high fish passage design depth. Meaning once stable, the element should have a portion exposed to the air, or nearly exposed, at the high fish passage design flow. This relationship between water depth and roughness size is critical to providing the necessary energy dissipation and velocity reduction for fish to rest and move in higher gradient channels. Channels with low relative roughness (uniformly sized bed and bank material), are characterized as hydraulically smooth. Hydraulically smooth channels at high gradients provide little to no resting or holding areas for fish. Hydraulically smooth channels commonly fail to meet fish passage velocity criteria.

The above discussion was developed based on the relationship between natural D84 and D90 class material and bankfull depth for streams in Washington State with slopes greater than 2% (Barnard et al. 2013). Barnard et al. measured stream discharge and bed roughness, observing that the rock providing the bulk of velocity reduction and hydraulic diversity were those elements which had a dimension analogous to the bankfull depth of the channel. Over a diverse range of project sizes, NMFS has also observed that velocity conditions are most often passable when somewhere in the range of 20%-40% of the project surface area is occupied by roughness elements extending significantly into the water column at the bankfull discharge.

### **5.10.3.7 Technical components**

*The technical components, and their associated criteria, used in nature-like fishway project remain consistent with more traditional fish ladder designs and include the following:*

*Section 5.2, Fishway Entrance*

*Section 5.3, Auxiliary Water Systems*

*Section 5.6, Counting Stations*

*Section 5.7, Fishway Exit Control*

*Section 5.8, Fishway Exit Sediment and Debris Management*

*Section 5.11, Miscellaneous Considerations*

*Appendix H: Sizing Fish Ladder Pools Based on Energy Dissipation and Fish Run Size*

### **5.10.4 Monitoring and Maintenance**

*A monitoring and maintenance plan for nature-like fishways is required. The frequency of monitoring and maintenance needed will be determined in consultation with NMFS. The plans should address how morphology and fish passage hydraulics will be monitored and modified, as needed, by developing an adaptive management approach that identifies triggers for when additional actions are to be implemented that address changes in nature-like fishway channel morphology and hydraulic conditions.*

#### **5.10.4.1 Passage assessment**

*Depending on project-specific considerations, monitoring may include an assessment of passage efficiency via fish tagging or fish counts. This monitoring criterion will be identified by NMFS on a project-by-project basis.*

#### **5.10.4.2 Channel stability**

*The loss or displacement of bed and bank material after a high-flow event does not necessarily equate with a failure of the nature-like fishway to maintain passage conditions. Any resulting loss or displacement of bed and bank material should be evaluated to determine the effects, if any, on passage criteria. Needed modification or repairs to bring the fishway into criteria should be discussed with NMFS and implemented by the facility owner. Proposed actions to bring the design into compliance with velocity criteria should be approved by NMFS.*

#### **5.10.4.3 Channel velocity**

*Channel velocity should be verified through post construction monitoring. When average channel velocity exceeds 5 ft/s at the high fish passage design flow needed modifications or repairs to bring the fishway into criteria should be identified be discussed with NMFS and*

*implemented by the facility owner. Proposed actions to bring the design into compliance with velocity criteria should be reviewed by NMFS.*

Two methods of measuring average velocity are used. First, longitudinal, or reach average velocity is measured. This is defined as the travel time of a particle beginning at the fishway exit and ending at the entrance, divided by the fishway length, and reported in ft/s. The velocity. Second, cross section average velocity is measured. Cross section velocity is measured at discrete sections of the fishway not associated with a hydraulic drop. Cross sections are measured every 40 feet of fishway beginning immediately upstream of the fishway entrance.

## **5.11 Miscellaneous Considerations**

### **5.11.1 Security**

*Fishway facilities and areas should be secured to discourage vandalism, preclude poaching opportunity, and provide for public safety.*

Security fencing around the facility and grating over the fishway may be required.

### **5.11.2 Access**

*Access for personnel to all areas of the fishway should be provided to facilitate operational and maintenance requirements. Walkway grating should allow as much ambient lighting into the fishway as possible. Consideration should be given to providing access for personnel to each pool of the ladder to support fish salvage operations.*

### **5.11.3 Edge and Surface Finishes**

*All metal edges in the flow path used for fish migration should be ground smooth and rounded to minimize risk of lacerations. Concrete surfaces should be finished to ensure smooth surfaces, with 1-inch-wide, 45-degree corner chamfers.*

### **5.11.4 Protrusions**

*Protrusions that fish could contact, such as valve stems, bolts, gate operators, pipe flanges, and permanent ladders rungs, should not extend into the flow path of the fishway.*

### **5.11.5 Exposed Control Gates**

*All control gates exposed to fish (e.g., entrances in the fully open position) should have a shroud or be recessed to minimize or eliminate fish contact.*

### **5.11.6 Maintenance Activities**

*To ensure fish safety during in-season fishway maintenance activities, all fish ladders should be designed to provide a safe egress route or safe holding areas for fish prior to any temporary (i.e., less than 24 hours) dewatering. Longer periods of fishway dewatering for*

*scheduled ladder maintenance should occur outside of the passage season and with procedures in place that allow fish to be evacuated in a safe manner.*

## **5.12 Operations and Maintenance Considerations**

### **5.12.1 Activity Near the Ladder**

*There should be no construction or heavy activity within 100 feet of a ladder entrance or exit or within 50 feet of any other portion of the ladder, but this can be reviewed on a case by case basis.*

### **5.12.2 Maximum Outage Period**

*A fishway should never be inoperable due to mechanical or operational issues for more than 48 hours during the fish passage season of any anadromous species.*

# 6 Exclusion Barriers

## 6.1 Introduction

Upstream-migrating salmonids are often attracted to areas of a river where flow is concentrated or velocities are high such as the discharge from a hydroelectric powerhouse. This behavior may cause fish to attempt to ascend a barrier at locations where passage is poor or blocked, which could result in the following:

- Injuries (e.g., lacerations, abrasions) caused by
  - Brushing against rocks or structures while swimming in turbulent areas
  - Jumping and striking rocks or structural projections
- Direct or delayed mortality due to injuries
- Migration delays

Exclusion barriers are structures or devices that are designed and used to halt the upstream migration of fish (BOR 2006). These barriers can guide fish to an area where upstream migration is allowed or to holding, sorting, evaluation, and transportation facilities. They are also used to prevent fish from entering an area where no upstream egress or suitable spawning habitat exists. For example, exclusion barriers could be required to protect upstream-migrating salmon and steelhead from injuries or mortality caused by ascending powerhouse turbine draft tubes or tunnels. Exclusion barriers can also be used for the following:

- Preventing fish from entering return flow from an irrigation ditch; tailrace of a power plant; channels subject to sudden flow changes; and channels with poor spawning gravels, poor water quality, or insufficient water quantity
- Guiding fish to counting facilities as well as trap facilities for upstream transport, research, or broodstock collection

### 6.1.1 Fish Safety

*Exclusion barriers should be designed to minimize both the potential for fish injury and mortality and migration delays.*

Fish may be physically injured (e.g., lacerations, abrasions) when attempting to pass exclusion barriers in migration pathways (FERC 1995). Therefore, barrier design and operation should consider and eliminate sources of injury due to shallow depths, exposed components, and rough surfaces. Barriers that are poorly designed can cause fish to delay migration while undertaking multiple attempts to pass the barrier.

### **6.1.2 Barriers Used to Collect Information**

*Installing exclusion barriers solely for the purpose of collecting information needed for fisheries management will be discouraged, especially if ESA-listed fish are present in the watershed.*

### **6.1.3 Other Species**

*Installing an exclusion barrier in river systems with multiple species of migratory fish should be carefully considered because some designs may inadvertently block the upstream and downstream movement of non-target species.*

Conversely, exclusion barriers may also be used to restrict the movement of undesirable species into upstream habitat (Clay 1995) such as sea lamprey in the Great Lakes (McLaughlin et al. 2007).

### **6.1.4 Flow Range**

*All barriers should be designed to function safely over the expected design range of flow conditions for the site when target fish are present (BOR 2006).*

## **6.2 Types of Exclusion Barriers**

Barriers to upstream fish passage are either physical or behavioral (e.g., acoustic, chemical, thermal, or lighting). They can be natural or fabricated. Natural barriers consist mainly of waterfalls and debris jams, whereas fabricated barriers consist mainly of dams, culverts, and log jams (Powers and Orsborn 1985). This chapter focuses on fabricated physical barriers, which present fish with structures or conditions that block farther upstream migration.

Fabricated physical barriers are classified into three categories: diffusers, weirs, and drop structures (Figure 6-1). Picket and weir barriers rely on bars racks, pickets, porous rigid panels, screens, or fences to physically exclude fish from entering an area. Fixed bar racks and picket barriers have similar meanings and purposes, and fish passage designers often use these terms interchangeably. However, the term ‘picket barrier’ carries an added nuance—these barrier panels tend to guide fish in some preferred direction—in addition to blocking farther upstream passage. Figure 6-2 is a schematic illustration of a temporary fish weir that uses pickets to guide fish to a trap at the riverbank.



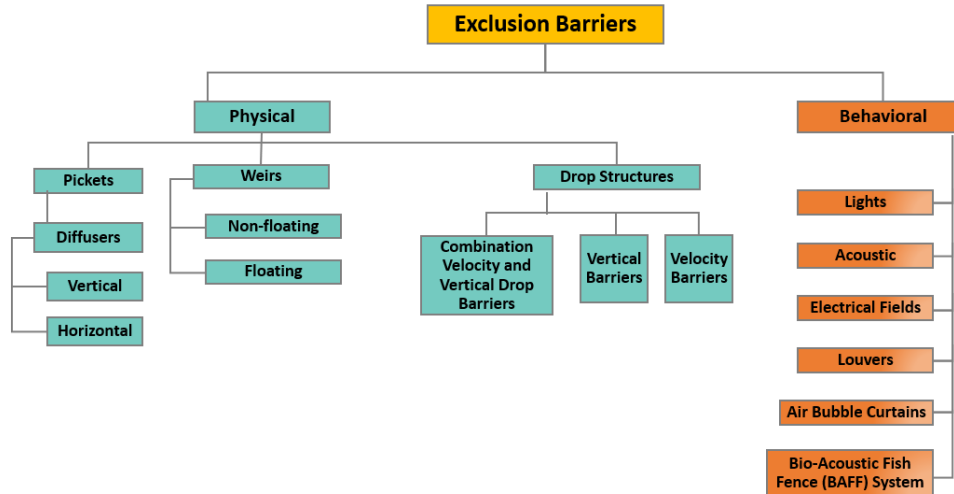

Figure 6-1. Classifications of exclusion barriers

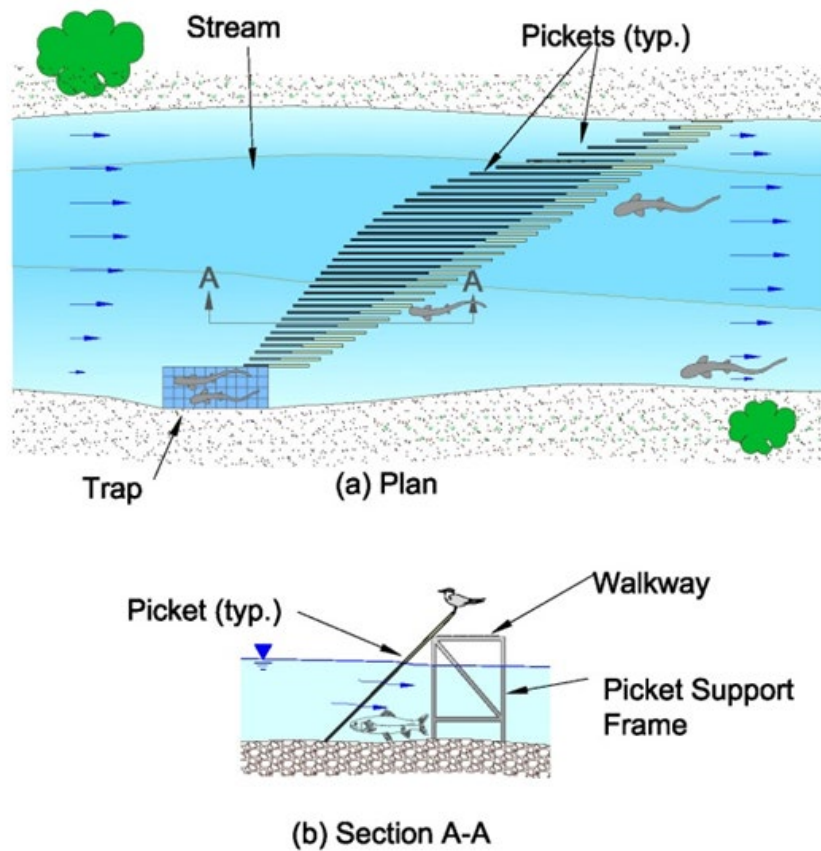

Figure 6-2. Fish weir constructed with pickets in plan (a) and section (b) views

Advantages of pickets and weir barriers include the following:

- They induce a small loss of head under clean and partially plugged conditions.
- They can function over a wide range of river flow stages.
- They can be designed to be removable.

Disadvantages of pickets and weir barriers include the following:

- Bar spacing that is too wide will not function effectively as a barrier, and bar spacing that is too narrow can collect debris more quickly than it can be removed. Striking a balance between the competing design objectives of excluding fish while not collecting more debris than can be managed may be difficult or impossible, depending on the river system and target fish species being excluded.
- Downstream juvenile and adult fish that need to pass the barrier can be excessively delayed and, in some designs, injured or killed. It is important to recognize that this type of barrier can cause injury and mortality to downstream migrants.
- Barrier components require periodic cleaning and are subject to rapid plugging (BOR 2006).

Drop structure barriers involve a combination of local hydraulic conditions downstream of a barrier and the swimming capabilities of the species and life stage to block migration (Powers and Orsborn 1985). They create hydraulic conditions that exceed the swimming or leaping capabilities of the fish to overcome the hydraulic condition. Examples include velocity barriers, vertical drop barriers, and velocity drop barriers. Hydraulic conditions at a specific site function as a barrier when one or more of the following conditions are present:

- Water velocity downstream from a barrier exceeds the swimming speed of fish.
- A standing wave develops downstream of the barrier that fish cannot pass through, or it forms too far downstream to allow the fish to rest before bursting upstream.
- A downstream plunge pool is too shallow to allow fish to jump the barrier.
- Barrier height exceeds jumping ability of fish.

Advantages of drop structure barriers include the following:

- These have lower maintenance requirements compared to picket and weir barriers.
- Debris passes over the barrier with flow (instead of plugging the barrier, which can be the case with structural barriers).
- All species and life stages of fish whose swimming capabilities are weaker than the species the barrier was designed to address are excluded.
- The passage of downstream migrants over drop barriers is usually safer than through picket and weir barriers.

Disadvantages of drop structure barriers include the following:

- They require a significant head to function properly.
- Their performance depends on maintaining a minimum head differential across the barrier.
- The pool upstream of the barrier structure may increase sediment deposition, which reduces channel capacity (BOR 2006).
- Drop structures may create a serious hazard to boaters and swimmers and precautions to protect boaters and swimmers should be included in the design.

Several reports contain additional information on the topic of exclusion barriers and fish swimming performance. Bell (1991) provides information on the swimming and jumping capabilities of various salmonid species. Powers and Orsborn (1985) provide equations for calculating maximum swim distances and estimating leap height and distance. Katopodis (1992)

provides endurance curves for fish of various lengths for the two main modes of fish locomotion and a formula for calculating swimming distance. The two main modes of locomotion are anguilliform body shapes (e.g., lamprey and Burbot) and subcarangiform body shapes (e.g., anadromous salmonids and various freshwater species such as bass, suckers, and chub).

### 6.3 Picket and Weir Barriers

Physical barriers typically rely on a combination of low-velocity flow discharged through bar racks, pickets, diffusers, screens, or fences to physically block fish from entering an area. Picket and weir barriers include fixed bar racks, picket panels (Figure 6-3), diffusers (a specialized form of picket barrier usually used in AWS in fishways), horizontal outlet diffusers, and a variety of hinged, floating weir designs and framework-supported (rigid) weir designs. The clear opening between bars in bar rack panels or pickets in picket panels should be sufficiently narrow to create a barrier to the smallest-sized migrant fish being excluded from farther passage upstream. Depending on the design and site conditions, weir barriers may need to be removed during high-flow events to prevent structural damage, which potentially reduces the barrier's ability to prevent target fish from passing into undesirable areas.



**Figure 6-3. Picket barrier panels under construction at the Slide Creek tailrace barrier located on the North Umpqua River, Oregon**

Because both debris and downstream-migrating fish must pass through physical barriers, sites should be selected based on the following design objectives:

- Minimizing the entrainment of debris
- Maximizing the ability to remove debris
- Preventing the entrainment and delay of downstream-migrating fish and adult fish that fall back across the barrier
- Maximizing the ability to rapidly remove and bypass any fish that are entrained on the barrier
- Allowing the most advantageous orientation of the barrier (typically angled to guide fish to a collection point)

### **6.3.1 Risk of Fish Impingement**

*If adult fish are exposed to the upstream side of physical barriers, they have a high likelihood of being impinged. Therefore, these types of barriers cannot be used in waters containing species listed under the ESA unless they are continually monitored by personnel on site and have an approved operational plan and a facility design that allows impinged or stranded fish to be removed in a timely manner and prior to becoming injured. Also, these types of barriers should not be used at sites where adult fish are actively migrating downstream or may inadvertently pass over a nearby dam or weir in a downstream direction prior to reorienting again to continue their upstream migration.*

In addition to blocking the upstream passage of adult fish, physical barriers can effectively block or injure fish migrating downstream (e.g., steelhead kelts, adult salmon that passed a dam and subsequently migrated back downstream, juvenile salmonids, and resident fish). This can impact population productivity and should be fully considered during the planning process.

### **6.3.2 Debris**

*Physical barriers should be continually monitored for debris accumulations, and debris should be removed before it concentrates flow and results in the velocity and head differential criteria being exceeded (Sections 6.3.3.2 and 6.3.3.3). Additionally, excessive debris loading could cause permanent damage to weir structures.*

Allowing debris to accumulate on components of physical barriers results in increased water velocity through the remaining open areas. As debris accumulates, the potential for impinging downstream migrants increases progressively and can reach unacceptable levels that result in mortality and injury. Concentrating flow through the remaining open areas of the barrier (e.g., the open picket area) will also attract upstream migrants to these areas. This can increase the potential for injury due to adult fish jumping into structural components and for fish accessing unwanted areas because they jumped and landed over the barrier.

### **6.3.3 Picket Barriers and Fixed Bar Racks**

Picket barriers and fixed bar racks create a uniform, low-velocity flow that is discharged through a series of bars or screens that cover the entire exclusion area.

The following specific criteria or guidelines apply to picket barriers and fixed bar racks.

#### **6.3.3.1 Openings**

*The spaces between bars of a diffuser should be sized to prevent fish passage and injury (Bates 1992). The clear opening between bars in bar rack panels, between pickets in picket panels, and between panels and abutments should be less than or equal to 1 inch to exclude anadromous salmonids and less than or equal to 0.75 inch to exclude Pacific lamprey. Smaller openings may be required if resident species are also present that need to be excluded by the facility.*

Openings larger than 1 inch may allow the heads of small salmon and steelhead to pass through the picket opening. This can lead to salmonids and other species becoming caught on the picket by their operculum that covers and protects the gills. Fish caught in this manner—between bars or pickets and gaps between panels or panels and abutments—often die because they are unable to extricate themselves off the picket.

#### **6.3.3.2 Design velocity**

*The average velocity through pickets should be less than 1 ft/s for all design flows (Clay 1995). The maximum velocity through the pickets should be less than 1.25 ft/s, or one-half the velocity of adjacent passage route flows, whichever is lower. When river velocities exceed these criteria, such as due to increasing flows or debris accumulations, the picket barrier should be removed.*

The average design velocity is calculated by dividing streamflow by the total submerged picket area over the design range of streamflows (Gauley et al. 1966). As discussed in Section 6.3.2, non-uniform or excessive velocities through the structure can create false attraction conditions that delay fish and induce upstream migrants to attempt to jump over the barrier, potentially injuring the fish.

#### **6.3.3.3 Head differential**

*The maximum head differential under fouled conditions should not exceed 0.3 foot above the normal head differential across the pickets that occurs under clean picket conditions. If this differential is exceeded, the pickets should be cleaned as soon as possible.*

Excessive head differential (head loss) through the structure can cause a cascading effect of water through the pickets, which increases the likelihood of upstream migrating fish leaping at the structure. Clay (1995) and DOI (1987) provide formulas to calculate head loss through picket barriers and trash racks.

#### **6.3.3.4 Debris and sediment**

*A debris and sediment removal plan should be considered in the design of the barrier that anticipates the entire range of conditions expected at the site. Debris should be removed before accumulations develop that violate the average design river velocity and head differential criteria (Sections 6.3.3.2 and 6.3.3.3, respectively).*

#### **6.3.3.5 Orientation of physical barrier**

*Physical barriers should be designed to lead fish to a safe passage route.*

Leading fish to a safe passage route can be achieved by angling the structural barrier toward the route, providing nearly uniform velocities across the entire horizontal length of the structural barrier, and providing a sufficient level of attraction flow that leads fish to the route and minimizes the potential for fish being falsely attracted to flow coming through the picket barrier.

#### **6.3.3.6 Picket freeboard**

*Depending on the angle of the pickets (from vertical), the pickets should be designed such that they extend out of the water and at least 2 vertical feet above the water surface at the upper design flow level.*

The purpose of the picket freeboard is to prevent fish from leaping over the barrier. Note that if the angle of the pickets is relatively steep, a freeboard of 2 feet may be insufficient to block stronger fish from leaping over the pickets, depending on site-specific conditions.

#### **6.3.3.7 Submerged depth**

*The minimum depth at the picket barrier at low design flow should be 2 feet for at least 10% of the river cross section at the barrier. Picket barriers should be sited where there is a relatively constant depth over the entire stream width.*

#### **6.3.3.8 Picket porosity**

*The picket array should have a minimum of 40% open area.*

Picket barriers with insufficient porosity may generate excessive head loss for the given river velocity. This head loss is exhibited as a cascade of water as it passes through the pickets, which may induce fish to jump and increase the potential for injury at the barrier.

#### **6.3.3.9 Picket construction and material**

*Pickets should comprise flat bars where the narrow edge of the bar is aligned with flow or round columns of steel, aluminum, or durable plastic. Other shapes may be approved by NMFS, but should not increase the risk of fish impingement.*

Picket panels should be of sufficient structural integrity to withstand high streamflows and some debris loading without deforming (i.e., without exceeding the clear opening criteria cited in Section 6.3.3.1, compromising the cleaning system, or permanently changing the shape of the picket panel). Pickets that become permanently deformed should be repaired or replaced as soon as possible. Pickets that deform or bend to a point where the clear opening criteria cited in Section 6.3.3.1 is no longer met under the design flow and debris loading conditions incorporated into the design can create openings that allow fish to pass the barrier or become injured as they try to force their way through the pickets.

#### **6.3.3.10 Sill**

*A uniform concrete sill, or an alternative approved by NMFS, should be provided to form a foundation for the pickets and ensure that fish cannot pass under the picket barrier.*

### **6.3.4 Diffusers**

Diffusers are a specialized type of picket barriers or fixed bar racks where a flow control or hydraulic baffling structure is incorporated into the design to regulate flow through the barrier

or bar rack. Wall-oriented (i.e., vertical) and floor-oriented (i.e., horizontal) diffusers are most commonly used as part of the AWS in adult ladders to prevent adult fish from entering the AWS system or delaying their migration due to being attracted to AWS flow entering the ladder. Wall diffusers are also used as tailrace barriers to prevent fish from entering tailraces downstream of hydroelectric dams, while encouraging fish to continue to move upstream through another stream, river route, or channel.

The following specific criteria or guidelines apply to diffusers.

#### **6.3.4.1 Openings**

*The spaces between bars of a diffuser should be sized to prevent fish from passing through the bars or becoming injured (Bates 1992). The clear opening between pickets and between pickets and abutments should be less than or equal to 1 inch to block anadromous salmonids. These clear openings should be less than or equal to 0.75 inch to block Pacific lamprey. Smaller openings may be required if resident species are also present that need to be excluded by the facility.*

Wall diffusers consist of vertically oriented diffuser panels of flat bar stock using non-corrosive materials. The orientation of flat bar stock should be designed to maximize the open area of the diffuser panel. If smaller fish species or life stages are present, smaller clear openings between the bars may be required.

#### **6.3.4.2 Design velocity and orientation**

*The average velocity through a wall diffuser should be less than 1 ft/s for all design flows based on total submerged diffuser area. The maximum velocity at any point on the diffuser should be less than 1.25 ft/s, or one-half the velocity of flow in an adjacent passage route, whichever is lower. Diffuser velocities should be nearly uniform. The orientation of the diffuser should be selected that assists in guiding fish towards the safe passage route. The face of the diffuser panels (the surface exposed to the fish) should be flush with the wall or floor.*

These criteria are based on results of laboratory studies where passage times of spring- and fall-run Chinook salmon and steelhead increased progressively with increased diffuser flows and where diffuser velocities increased from 0.25 to 1.25 ft/s (Gauley et al. 1966).

#### **6.3.4.3 Porosity control baffles**

*Similar to juvenile fish screens, a diffuser should include a system of porosity control baffles located just upstream of the diffuser pickets to ensure the average velocities at the face of the diffuser can meet criteria.*

Porosity control panels control the amount of flow and velocities through the diffuser pickets and create a uniform flow condition at the face of the pickets.

#### **6.3.4.4 Debris removal**

*The diffuser design should include access for personnel to be able to remove debris from each diffuser. This criterion is not required when the intake to the diffuser water supply is equipped with a juvenile fish screen (Chapter 8).*

The dewatering screen system also removes debris from water being supplied to the diffuser.

#### **6.3.4.5 Edges**

*The edges of all diffuser surfaces exposed to fish should be rounded or ground smooth to the touch, with all edges aligning in a single smooth plane.*

Rounding and grinding smooth surfaces that fish can contact and making all diffuser surfaces flush reduces the potential for fish injury.

#### **6.3.4.6 Elevation**

*Wall-style diffusers should be submerged throughout the range of operation (i.e., the top elevation of the wall diffuser should be below the water surface elevation associated with the low flow selected for the design).*

Maintaining a submerged wall-style diffuser prevents water from cascading through the diffuser, which can induce adult fish to leap at the surface disturbance and become injured when contacting the diffuser material and wall and delay their migration up the ladder.

### **6.3.5 Horizontal Outlet Diffusers**

A horizontal outlet diffuser is a device that can be used to prevent fish from entering a drain or discharge pipe. They can also be used below a powerhouse at the turbine draft tube outlet to prevent adult fish from ascending up the draft tube discharge during unit start up or shut down or during normal operations if draft tube velocity is low (typically less than 16 ft/s; Figure 6-4). This type of diffuser also prevents fish from entering the draft tube and contacting the turbine runners, which may result in injury or mortality. If the turbine draft tubes are located in close proximity to the entrance of an upstream passage system (e.g., a fishway), a horizontal outlet diffuser system may be the appropriate choice for an exclusion system.



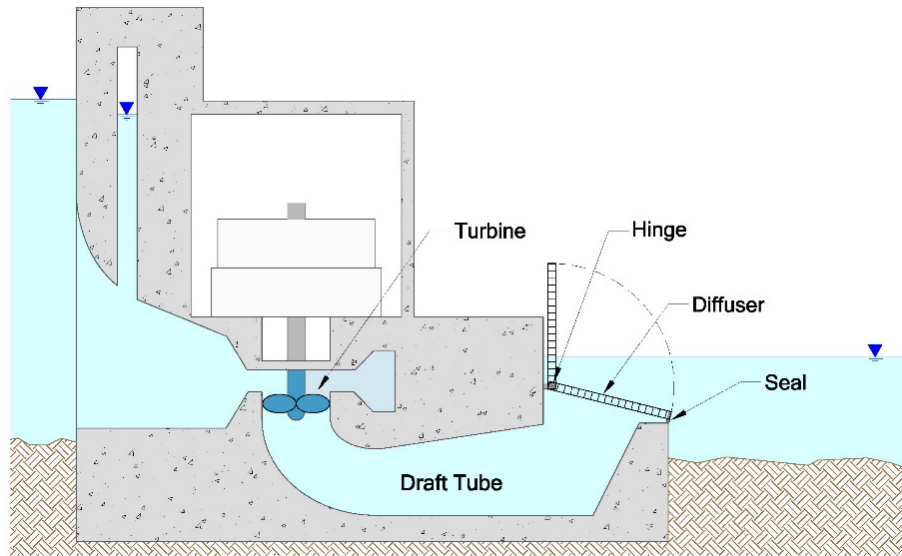

**Figure 6-4. Layout of a horizontal outlet diffuser covering the entrance to a turbine draft tube**

### 6.3.5.1 Design velocity

*Average flow velocity exiting the horizontal outlet diffuser grating should be less than 1.25 ft/s and be distributed as uniformly as possible. The maximum point velocity should not exceed 2 ft/s.*

### 6.3.5.2 Porosity control baffles

*Similar to juvenile fish screens, diffusers should include a system of porosity control baffles located just upstream of the diffuser pickets to ensure the average velocities at the face of the diffusers can meet criteria.*

Porosity control panels control the amount of flow and velocities through the diffuser pickets and create a uniform flow condition at the face of the pickets.

### 6.3.5.3 Openings

*The spaces between bars of a diffuser should be sized to prevent fish passage and injury (Bates 1992). The clear opening between bars, and between bars and abutments, should be less than or equal to 1 inch to exclude anadromous salmonids and less than or equal to 0.75 inch to prevent Pacific lamprey from entering the chamber behind the diffuser. Smaller openings may be required if resident species are also present that need to be excluded by the facility.*

Horizontal outlet diffuser panels consist of non-corrosive, horizontally oriented flat bar stock. The orientation of flat bar stock should be designed to maximize the open area of the diffuser panel.

#### **6.3.5.4 Edges**

*The edges of all diffuser surfaces exposed to fish should be rounded or ground smooth to the touch, with all edges aligning in a single smooth plane.*

Rounding and grinding smooth surfaces that fish can contact and making all diffuser surfaces flush reduces the potential for fish injury.

#### **6.3.5.5 Debris removal**

*The diffuser design should include access for personnel to be able to remove debris from each diffuser. This criterion is not required when the intake to the diffuser water supply is equipped with a juvenile fish screen (Chapter 8).*

Trash (bar) racks installed at the intake to the diffuser system and a juvenile fish screen (if installed) remove debris from water being supplied to the diffuser.

#### **6.3.5.6 Submergence**

*Horizontal outlet diffusers should be submerged a minimum of 2 feet for all tailwater elevations.*

### **6.3.6 Fish Weirs**

Fish weirs are physical barrier systems that are constructed across a stream (Figure 6-2). The purpose of fish weirs is to prevent fish from passing upstream of the weir and guide upstream-migrating fish to a trap. The weirs are constructed of panels of metal or plastic pickets that extend from the bottom of the stream to an elevation several feet above the water surface. The clear spacing between the pickets is selected based upon the size of the target species being trapped. When viewed from above, weirs are usually placed at angles greater than 90 degrees from the main thread of the current (Figure 6-2). The trap is placed at the most upstream area of the weir. The angle between the direction of stream or river flow and the weir results in the weir being longer than if it was positioned perpendicular to the bank and reduces water velocity through the pickets.

#### **6.3.6.1 Types of fish weirs**

The two most commonly used types of weirs in the WCR are rigid (frame-supported) weirs and floating resistance board picket weirs (Figure 6-5). Weirs can be temporary or permanent.

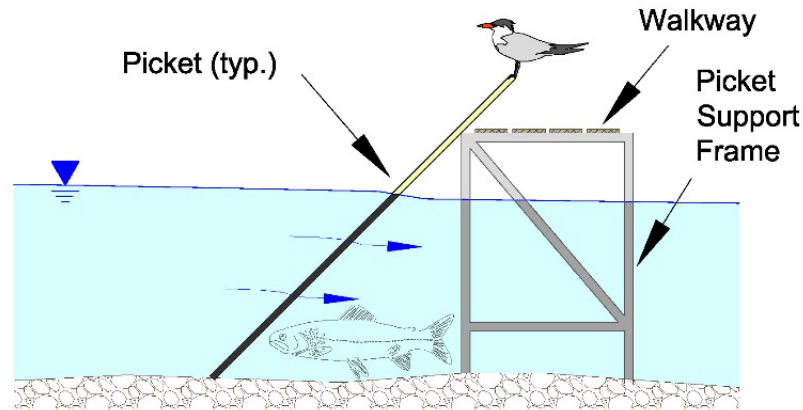

(a) Cross section through rigid (frame-supported) picket weir.

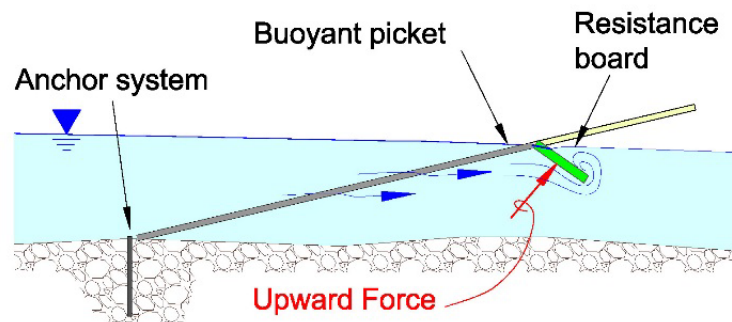

(b) Cross section through floating resistance board picket weir.

Figure 6-5. Cross sections of rigid and floating picket weirs

The pickets in rigid weirs are placed at an angle greater than 45 degrees above the water surface. Clean pickets in a floating weir have a very small angle above the water surface, and increased flow velocity and debris loading can further reduce the angle and can eventually submerge the floating weir panels.

Rigid weirs use panels of solid metal rods or hollow conduits that are supported by rigid frameworks (Figure 6-6). The supporting structures for temporary weirs can be light metal trusses or frames that are installed at the start of the fish passage season and are removed at the end of the trapping season. Permanent installations consist of foundations, frameworks, and abutments that stay in the river. However, the pickets at permanent installations are removed from the weir during periods when fish are not being trapped and during winter at locations that experience icing.



**Figure 6-6. Elk Creek Dam picket weir (Elk Creek, Oregon)**

The main advantage of rigid weirs is that the pickets are supported both along the river bottom and above the water surface, which may provide greater lateral stability and help to maintain constant spacing between the pickets. The main disadvantage of rigid weirs is that they are more susceptible to damage with increased debris loads experienced during high flows. High flows and debris can create sufficient force on the face of the panels such that the entire structure can be washed away. Some trap operators remove the pickets from the weir when they anticipate the occurrence of high flows.

Floating resistance board weirs are constructed using panels of hollow plastic piping or conduits that are capped at both ends to provide buoyancy. A resistance board at the downstream end of the pickets directs the local flow downwards, which creates an uplift force and a drag force on the pickets (Tobin 1994). In situations where the resistance board does not provide enough uplift (i.e., under conditions of low stream velocities), the board can be replaced with a long, linear float to support the picket panels. The pickets extend downstream and above the water surface to prevent fish from jumping over. The Alaska Department of Fish and Game has developed a user's manual for installing, operating, removing, and storing resistance board weirs used to count adult salmon migrating upstream based on direct experience, providing considerable information on this type of picket barrier (Stewart 2003).

The advantage of floating weirs is that they are less prone to damage over a wider range of flows and debris loads. High flows can also submerge the panels, which also tends to move debris off the panels and reduce the downstream pressure on the panels. The main disadvantages of floating weirs include the following:

- Debris can easily be trapped on top of the pickets due to the low angle of the panels.
- Fish can pass over the pickets when the pickets are submerged during high flows.
- The pickets may be more susceptible to lateral current forces because the pickets are supported only by the bottom of the river.
- In situations where adult fish are upstream of the weir and they fall back downstream, or they are migrating downstream, the fish can easily become stranded on the pickets and die due to

the low approach angle and force of the flow that tends to push the fish up onto the dry part of the pickets.

#### **6.3.6.2 Site selection**

*Weirs should be constructed at sites that have the following characteristics (Zimmerman and Zabkar 2007):*

- *Construction, operation, and maintenance activities can be conducted safely.*
- *The river should be wide and shallow (about 3 feet maximum depth at normal flows) with uniform flow distribution.*
- *The substrate should consist of gravel and small cobbles and be without boulders in the weir alignment.*
- *Traps should have sufficient flow depth during minimum expected river flow stages and be accessible during flood flows. More than one trap location may be required.*

The site should be low gradient and straight, with uniform depth and width, and have areas of sufficient depth for adult holding pools upstream and downstream of the weir (Hevlin and Rainey 1993).

#### **6.3.6.3 Velocity**

*Water velocity at the river channel cross section of the weir location should be a maximum of 2 ft/s at low flows if a concrete apron is used (Hevlin and Rainey 1993), and velocity and depth should allow for safe access to the weir under normal flows (Zimmerman and Zabkar 2007)*

#### **6.3.6.4 Picket spacing and freeboard**

*The clear spacing between the pickets and the freeboard has the same requirements as those for other structural barriers (Sections 6.3.3.1, 6.3.4.1, and 6.3.5.2). The clear opening between bars in bar rack panels, between pickets in picket panels, and between panels and abutments should be less than or equal to 1 inch to exclude anadromous salmonids and less than or equal to 0.75 inch to exclude Pacific lamprey.*

#### **6.3.6.5 Suitability at sites with downstream migrants and monitoring**

*Fish weirs are not suitable for sites with downstream-migrating adult fish (e.g., steelhead kelts, salmon that pass the structure but migrate downstream [i.e., fallback], and resident fish). If deployed in these situations, weir operators should provide around-the-clock monitoring and fish salvage efforts for as long as these barriers are in place (Section 6.3.1).*

While blocking the upstream passage of fish, fish weirs can also block the migration of, or injure, fish migrating downstream (e.g., steelhead kelts, adult salmon, juvenile life stages, and resident fish) and prevent them from completing their life cycle. When weir pickets are at a low angle with respect to the water surface (i.e., floating weirs), downstream-migrating adult fish can become stranded as they are pushed downstream along the pickets and the water becomes shallow. Juvenile passage openings or structures should be provided as part of the design, or

these weirs should be removed during the juvenile salmonid outmigration season. When rigid weirs are properly designed and sited, adult and juvenile fish that are migrating downstream are guided along the face of the weirs to the downstream apex of the weir and the shoreline where they can be trapped or released downstream.

## **6.4 Drop Structure Barriers**

Drop structure barriers create conditions that target species are incapable of overcoming based on their swimming abilities or behavioral traits. A condition affecting swimming ability is the creation of a shallow, high-velocity flow for a significant distance, which most salmonids cannot pass. Hydraulic conditions can also interact with fish behaviors, including the reluctance of American shad to pass through a submerged orifice in a ladder or leap a ladder weir under plunging flow conditions. Both are examples of incorporating knowledge about the swimming ability and behavior of target species into facility designs so that the facility becomes a migration barrier. Note: Drop structures may create a serious hazard to boaters and swimmers, and precautions to protect boaters and swimmers should be included in the design.

### **6.4.1 Orientation of Drop Structure Barriers**

*As with physical barriers, drop structure barriers should be designed to lead fish to a safe passage route.*

This can be achieved by angling the barrier toward a safe passage route and by providing the following:

- Nearly uniform velocities across the entire horizontal length of the barrier
- Sufficient attraction flow that leads fish into the safe passage route and minimizes the potential for false attraction

### **6.4.2 Upstream Impacts**

*Since this type of barrier creates an upstream impoundment, the designer should consider backwater effects upstream of the barrier that may induce loss of power generation, inundation of property, and sediment deposition in the impoundment.*

### **6.4.3 Combination Velocity and Vertical Drop Barriers**

#### **6.4.3.1 Description and purpose**

A combination velocity and drop barrier consists of a weir and concrete apron (Figure 6-7). Upstream passage is prevented by a shallow, high-velocity flow on the apron with an impassable vertical jump over the weir upstream of the apron. A fish that negotiates the apron and reaches the base of the weir is unable to pass the weir due to insufficient water depth needed to reorient its position and the lack of a pool needed to accelerate to leap over the weir sill (Wagner 1967; Weaver et al. 1976).

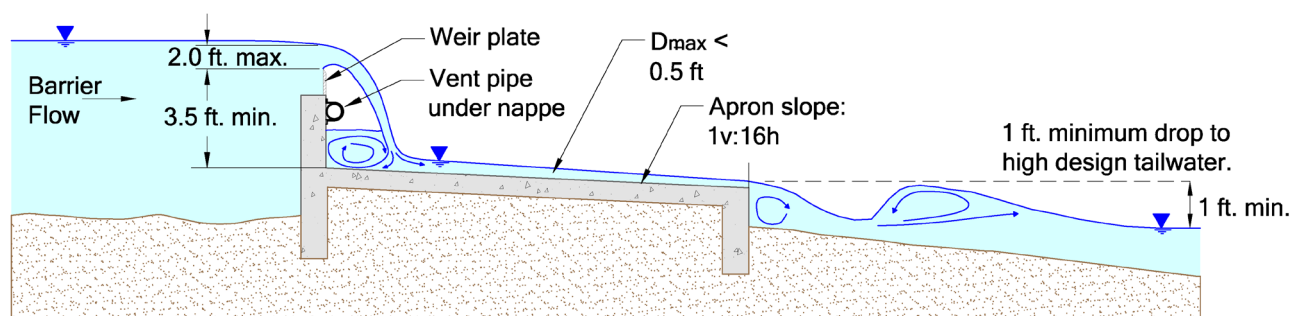

**Figure 6-7. Cross section of a combination velocity and vertical drop barrier**

### 6.4.3.2 Specific criteria and guidelines

#### 6.4.3.2.1 Weir height

*The minimum weir height relative to the maximum apron elevation is 3.5 feet (Wagner 1967).*

This design assumes a straight, uniform, linear weir crest that will create uniform flow conditions on the apron. Labyrinth-style weirs are not allowed since they concentrate flow on the apron and create non-uniform flow conditions downstream.

#### 6.4.3.2.2 Apron length

*The minimum apron length (extending downstream from the base of a weir) is 16 feet.*

This criterion is based, in part, on results of laboratory studies where adult Chinook salmon and steelhead were blocked by a velocity barrier dam with a 15-foot-long apron under two test conditions: 1) a vertical dam height of 3 feet with 1 foot of head; and 2) a vertical dam height of 4 feet with 2 feet of head (Slatick and Wagner 1989).

#### 6.4.3.2.3 Apron slope

*The minimum apron slope in a downstream direction is 1:16 (vertical:horizontal).*

#### 6.4.3.2.4 Weir head

*The maximum head over the weir crest is 2 feet.*

Other combinations of weir height and weir crest head may be approved by NMFS on a site-specific basis.

#### 6.4.3.2.5 Apron elevation

*The elevation of the downstream end of the apron should be greater than the tailrace water surface elevation corresponding to the high design flow (BOR 2006). There should be at*

least 1 foot of elevation difference between the water surface elevation at the downstream end of the apron and the high design tailwater elevation.

#### **6.4.3.2.6 Flow venting**

*The flow over the weir should be fully and continuously vented along the entire weir length to allow a fully aerated flow nappe to develop between the weir crest and the apron (BOR 2006).*

Full aeration of the flow nappe prevents an increase in water surface behind the nappe, reducing the opportunity for fish to stage and jump the weir.

#### **6.4.3.2.7 Flow depth on the apron**

*Flow depth on the apron should not exceed 0.5 foot (Wagner 1967).*

At sites where a maximum depth of 0.5 foot cannot be maintained, apron velocities of 20 ft/s in association with a sill height (i.e., minimum weir height relative to the maximum apron elevation) of 5.25 feet have been used successfully (Wagner 1967).<sup>4</sup>

#### **6.4.3.2.8 Minimum flow velocity over the apron**

*A minimum velocity of 16 ft/s is recommended by Wagner (1967).*

The recommendation by Wagner (1967) is based on Weaver (1963) who reported that Chinook salmon and steelhead could swim against a 16-ft/s velocity for a distance of at least 85 feet in a test flume.

### **6.4.4 Vertical Drop Barriers**

#### **6.4.4.1 Description and purpose**

A vertical drop barrier functions as an exclusion barrier by providing head in excess of the leaping ability of the target fish species (Figure 6-8). Vertical drop barriers can be designed based on a concrete monolith, rubber dam, bottom-hinged leaf gate, or an alternative approved by NMFS.

---

<sup>4</sup> Wagner (1967) does not provide any additional information on this particular barrier configuration. If it is assumed that flow on the apron is 8 inches deep at 20 ft/s, the discharge per linear foot is approximately 13.5 ft<sup>3</sup>/s. This translates to a maximum of 2.5 feet of head over a sharp crested weir. This barrier configuration should be biologically tested before a prototype facility is constructed.



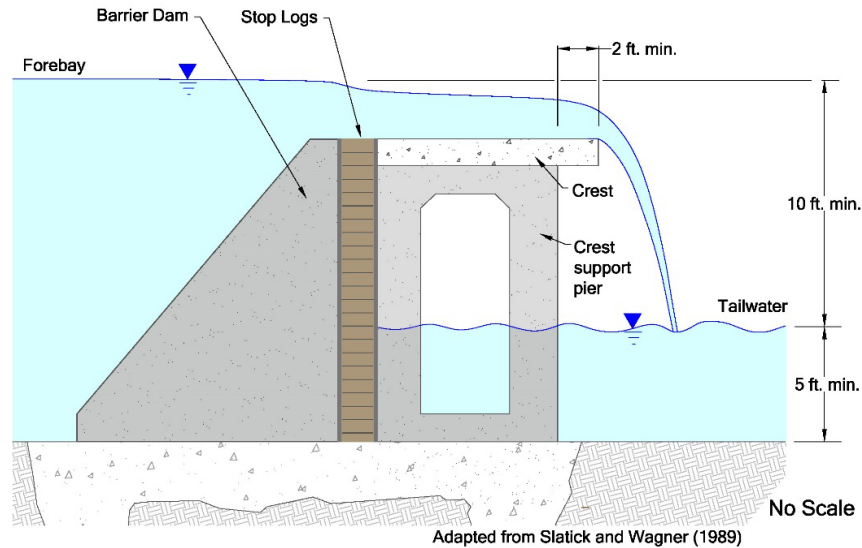

**Figure 6-8. Cross section of a vertical drop barrier**

## 6.4.4.2 Specific criteria and guidelines

### 6.4.4.2.1 Minimum height

*The minimum height of a vertical drop structure should be 10 feet relative to the high design flow (Wagner 1967; Bell 1991; Clay 1995). This is measured as the water surface level of the forebay relative to the water surface level of the tailrace.*

### 6.4.4.2.2 Cantilever

*If the potential for injury to fish from leaping exists, the downstream crest of the barrier should extend over the tailwater at least 2 feet beyond any structural surfaces.*

### 6.4.4.2.3 Minimum flow depth

*Provisions should be made to ensure that fish jumping at flow over the vertical drop structure will land without contacting any solid surface and in a pool that is a minimum of 5 feet deep.*

## 6.4.5 Velocity Barriers

Figure 6-9 shows a cross section of a velocity barrier and its main characteristics that include high water velocity and the long longitudinal length of the barrier over which the design velocity is maintained. The design approach is to provide a combination of water velocity, travel distance, and shallow depth that, taken together, exceed the swimming ability of the target fish.

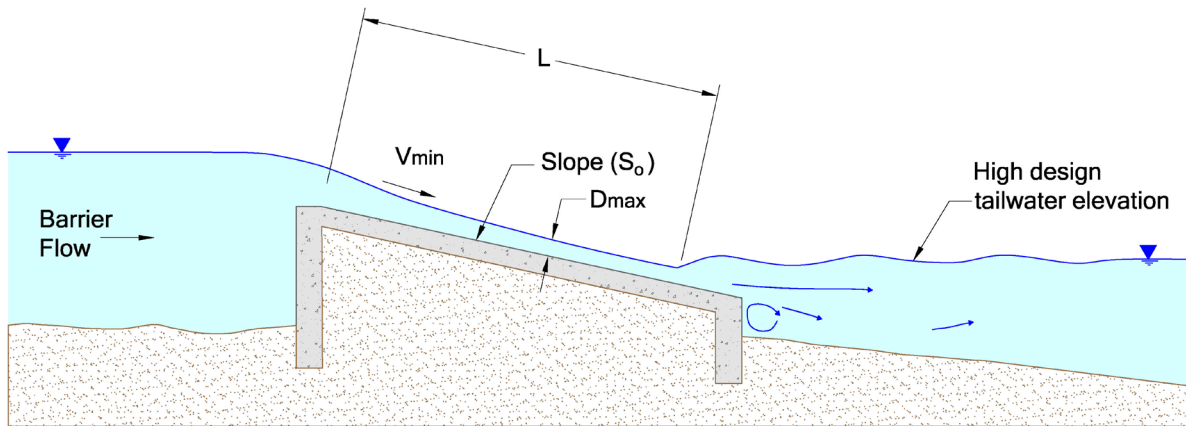

**Figure 6-9. Cross section of a velocity barrier**

Designing a velocity barrier to prevent the upstream migration of adult salmonids can be challenging due to their strong swimming capabilities. Experience has shown that salmonids will seek flow concentrations or discontinuities in flow (often near the edges of the flow) and use these features to find a route over this style of barrier. In addition to combining high velocity and shallow depth, the design should also create uniform flow conditions across the barrier, which can be difficult to achieve.

NMFS currently does not have criteria or guidelines for a velocity barrier.

NMFS will evaluate a proposed velocity barrier design based upon the hydraulic conditions created by the barrier and by comparing these conditions to the swimming capabilities of the target species. In general, velocity barriers are not recommended by NMFS because fish may spend a long time trying to negotiate the obstacle before seeking an alternate route, which delays the fish and may exhaust them in the process. As discussed in Section 6.3.3.5, barriers should also lead fish to a safe passage route, and NMFS will assess this when reviewing a proposed velocity barrier design.

## 6.5 Behavioral Barriers

Behavioral types of barriers, such as electric and acoustic fields, have had limited application and were ineffective in most cases (BOR 2006). While electric fields have been used as barriers for decades, persistent problems with early installations limited their widespread use (FERC 1995). These limitations included fish injury and mortality, safety, and effectiveness over a wide range of flow and environmental conditions (Clay 1961). Strobe lights and acoustical systems have been tested in various applications to block juvenile or adult fish from entering water intake systems. These systems were tested in the 1980s and 1990s and seemed promising at first (EPRI 1994) but were found to have limited effectiveness. Thus, electrical fields, strobe lights, acoustical systems, and other behavioral barriers are not widely used within the WCR and are considered experimental. Additional information regarding the various types of behavioral barriers and their performance and limitations may be found in Appendix C. Appendix C also provides information regarding the processes to be followed in order to use experimental devices such as behavioral barriers.

# 7 Adult Fish Trapping Systems

## 7.1 Introduction

Chapter 7 presents criteria and guidelines that address the design of new adult fish trapping systems. This chapter also includes criteria and guidelines that may apply to existing trapping programs that are being retrofitted. In both cases, traps should be designed to utilize known or observed fish behaviors to benignly route fish into a holding pool. The holding pool does not include a volitional exit, and once the fish are allowed or encouraged to exit the holding pool, they can be examined for research and management purposes and loaded into transportation tanks for transport to release locations or hatcheries.

*NMFS typically prefers the use of volitional passage for upstream fish passage facilities, as opposed to non-volitional facilities and operations. Volitional passage is defined as the passage of fish under all naturally passable flows, whereby a fish can enter and exit any passage apparatus or structure under its own power, instinct, swimming ability, and migration timing. Non-volitional is defined as the collection, handling, transportation, and release of adult fish from a collection site at or below a barrier to a release point located upstream from the barrier or location.*<sup>5</sup>

For some facilities, fish transportation is not a requirement and fish are trapped, monitored, sorted, and released from the trap to continue their upstream migration. For example, at some trapping facilities hatchery-origin fish are removed to protect wild-origin fish or collect hatchery broodstock. In the Pacific Northwest, certain areas within watersheds are designated as wild fish sanctuaries, and hatchery-origin fish should be collected and removed from traps located below these areas. Also, fish of a specific species or life stage or fish previously tagged for research purposes may also need to be collected and monitored at trap locations and then released.

The operational requirements for a trapping facility and its design are highly interdependent: management objectives for trap operation define the facility's functional design, and the objectives should be identified before trap design development can proceed. NMFS' primary objective is that a fish passage facility be designed and operated in a manner that the facility helps restore the viability of anadromous fish populations, which is why NMFS often prefers that volitional passage be used. Volitional passage facilities can operate 24 hours per day, 7 days per week, year-round.

However, there are instances where passing fish over a barrier using trap and haul techniques may be the only viable passage alternative. For example, thermal stratification can occur in

---

<sup>5</sup> An illustration of a trap and haul operation is available at [http://www.westcoast.fisheries.noaa.gov/fish\\_passage/about\\_dams\\_and\\_fish/trap\\_and\\_haul.html](http://www.westcoast.fisheries.noaa.gov/fish_passage/about_dams_and_fish/trap_and_haul.html).

reservoirs at high head dams during summer, resulting in temperature differentials between the fishway entrance and water released below the dam. This can affect how fish utilize volitional passage facilities, and a trap and haul program would provide passage to areas above the thermally stratified reservoir.

The success of collection and transport operations relies on a high degree of engineering, technical, and operational competence. The process is generally composed of the following distinct phases: (1) Collection, (2) Handling, (3) Transportation, and (4) Release. This sequence is sometimes abbreviated by the acronym ‘CHTR’. The essential idea is to engineer effective system components for each phase, and to consistently execute operations to move fish in a safe and timely manner to designated release location(s). This section provides guidance on how to collect, handle and release fish from a collection facility. For all of these steps, careful attention must be given to maintenance of aquatic conditions and water quality to keep fish in good condition. It is very important to properly acclimate fish to any changing aquatic conditions or environmental transitions. Stressors associated with the aquatic environment (as experienced by the fish) must be minimized and carefully managed. All technical details for each phase of the overall process must be properly addressed.

## 7.2 Types of Traps

There are two types of traps. The first type is where a trap is an integral component of the primary route of fish passage above a barrier. Examples of these traps include the following:

- Traps located directly adjacent to a barrier
- Traps at the upstream end of a fish ladder
- Traps that serve as holding box associated with broodstock collection facilities in tributary streams in conjunction with intermittent barriers

A collection and transport facility located at the upstream end of a fish ladder is the most common application of this type of trap.

The second type of trap is an off-ladder design wherein the trap is situated adjacent to a ladder such that it is not the primary route of passage and does not interfere with the normal operation of the ladder. The ladder provides volitional passage from the tailrace to the forebay of the barrier under normal conditions, but when necessary or desired, all or some fish can be diverted into the trap.

For both types of traps, once fish are in a trap they can be accessed for a variety of purposes, including the following:

- Enumeration
- Evaluation for tags and injuries
- Sampling for genetic identification
- Sorting for various management purposes
- Transportation to various locations
- Tagging to support fisheries management or research

Fish that are enumerated or evaluated can be released back into the ladder or at another location.

### 7.2.1 General Criteria

*Fish ladders should not be designed or retrofitted with in-ladder traps or fish loading facilities. Rather, fish holding and loading facilities should be placed in an adjacent, off-ladder location in order to route fish targeted for trapping purposes.*

Fishway ladder pools typically do not meet the requirements of trap holding pools. Therefore, use of fishway ladder pools to site traps can create adverse impacts to the migrating fish. These impacts include elevated stress, delay, injury, or mortality caused by turbulence, jumping at water being supplied to the holding pool, and handling. Locating the trap off-ladder allows the facility to have the operational flexibility to readily switch between volitional ladder passage and trapping modes of operation.

## 7.3 Design Scoping

### 7.3.1 Purpose

*Proposals to design new facilities or complete major upgrades to existing facilities should address the following issues, or at the very least show how the following issues were considered:*

- *Describe the objective of the trapping operation and identify how the fish will be counted, collected (including the expected holding densities), handled, sampled for research or management purposes, transported (how and what frequency), and released.*
- *Identify the number of fish that will be targeted and the total number potentially present. This should include the expected peak number of fish per day, seasonal and daily fish returns, future fish return expectations, expected incidental catch, etc.*
- *Identify the target species, including ESA-listed species.*
- *Identify other species likely to be present at the trap, including ESA-listed species.*
- *Describe the environmental conditions expected to occur during trap operation such as water and air temperature, flow conditions (lows and peaks), and debris load.*
- *Describe the location, duration, frequency, predicted fish numbers, and scale of the trap and haul operations by developing an operations plan for the trap.*
- *Describe the facility's security mechanisms and procedures that will be in place in the operations plan.*
- *Identify when, what and how many fish will be taken to what location and for what purpose for the entire trapping season. (Many times different species or origins have different destinations from the trapping facility. Understanding the fish disposition for each species, run type and origin plays a huge role in the facility design (e.g. number of holding tanks and raceways).)*
- *Describe the maximum duration of delay or holding within the trapping system for target and non-target species and life stages.*
- *If a Hatchery and Genetic Management Plan, ESA Section 4(d) Limit 7 Scientific Research and Take Authorization application, ESA Section 7(a)(2), or ESA Section 10(a)(1)(A) permit application exists, show how one of these documents was used as the basis for design of a*

*trapping facility. At least one of these types of documents will have to be developed for most trapping facilities and will be available for designing the facility.*

## **7.4 Fish Handling Criteria**

Section 7.4 provides criteria and guidelines that are applicable to handling fish in traps.

### **7.4.1 Nets**

*The use of nets to capture or move fish should be minimized or eliminated. If individual adult fish need to be moved, then they should be placed into rubber tubes with one end sealed. The tube should be partially filled with sufficient water to keep the head and gills of the fish submerged. Avoid handling the fish by hand, unless they have been adequately sedated. All fish should be handled with extreme care.*

### **7.4.2 Anesthetization**

*Fish should be anesthetized before being handled.*

The method of anesthetization for ESA-listed anadromous salmonids may be specified by the appropriate ESA permit, which should be in place prior to any directed take of listed species. The type of anesthetic to be used can be selected by agreement with NMFS during the design process and prior to submittal of an ESA permit request. Determination of the method and anesthetic used should be decided early in design, since each has different infrastructure requirements.

Once the anesthesia is selected protocols should be written to guide appropriate application of the chemical to allow for safe handling while minimizing the risk of over-exposure and mortality. The protocol should include details on water temperature and adjustment of dosage based on water temperature. Finally, a water temperature maximum should be set when fish handling will not be done.

#### **7.4.2.1 Recovery**

*Fish that have undergone anesthetization should be allowed to recover from the effects of the anesthetic before being released (Section 7.5.10).*

Fish require time to recover from the effects of anesthesia. The amount of recovery time needed will depend on several variables including the exposure time to the anesthesia, the water temperature (and general water quality conditions), and the individual sensitivity of the fish. Warm water temperatures and prolonged exposure to anesthetic will result in extended recovery times.

Fish should be monitored to ensure they are recovering. Signs of recovery include fish that are consistently upright and oriented, display normal gilling activity, and are responsive to stimuli.

During recovery fish should be protected from risk of impingement or accidental release back to the river (see specific guidance in Section 7.5.10).

### **7.4.3 Non-Target Fish**

*New or upgraded trapping facilities should be designed such that non-target fish can bypass the anesthetic tank.*

### **7.4.4 Frequency**

*Unless otherwise agreed to by NMFS, all fish (i.e., adults and juveniles of all species and sizes) should be removed from the trap holding pool and raceways at least once every 24 hours whenever the trap is in operation. When either environmental (e.g., water temperature extremes, low dissolved oxygen, or high debris load) or biological conditions (e.g., migration peaks or delay) warrant, fish should be removed more frequently to preclude overcrowding or adverse water quality conditions from developing (Section 7.5.5.2).*

### **7.4.5 Personnel**

*Trap personnel that handle fish should be experienced or trained to ensure that fish are handled safely.*

## **7.5 Trap Design Criteria**

Section 7.5 provides criteria and guidelines that apply to trap design.

### **7.5.1 Trap Components**

Trap systems should include the following components:

- *Removable diffusers or gates located within the fish ladder to block passage and guide fish into the trap*
- *A holding pool; a transition channel or port that connects the fish ladder to the holding pool; and a trapping mechanism as described in Section 7.5.4 (attraction flow is discharged via devices described in Section 7.5.4)*
- *A gate to prevent fish from entering the trap area during crowding operations*
- *A fish crowder (and brail if needed) to encourage adult fish to exit the off-ladder holding pool and enter sorting and loading facilities*
- *Separate holding pool inflow supply and outflow facilities*
- *Distribution flume used in conjunction with false weir or steepass systems to enable fish to exit the holding pool*
- *A lock or lift (or hopper) for loading fish onto the transportation truck*
- *A flume, pipe, or ladder to return fish either to the ladder or to the dam forebay where they can continue their upstream migration (when returning fish to the ladder, fish should be allowed to volitionally enter the ladder from a resting pool)*

## 7.5.2 General

### 7.5.2.1 Location

*The entrance to trap facilities should be located in a hydraulically stable, low-velocity (i.e., approximately 1.5 ft/s), accessible area of the upstream passage facility, similar to the requirements for a counting station (Section 5.6).*

This location allows fish to be more easily directed toward the trap entrance without excessive turbulence.

### 7.5.2.2 Flow

*Fish ladders should not experience any significant change in fishway flow volume during trap operations.*

Fish ladders are often designed to operate within a narrow range of flows; thus, changing the flow volume during trap operations can often compromise the function of the ladder. Depending on the design, it may be necessary to add or remove flow from the ladder in order to adjust for the operation of the trap.

### 7.5.2.3 Edges

*All trapping components exposed to fish should have all welds and sharp edges ground smooth to the touch to minimize injuries. Additional features, such as neoprene padding covered by UV stabilized rubber, may also be required to minimize fish injuries.*

### 7.5.2.4 Fish safety

*Provisions should be included in the facility design to provide guaranteed safety to the fish or a method or manner to release fish back to the river in case of emergency (e.g., power outage or loss of water supply).*

Fish safety provisions may include guaranteed water supply, water level and water supply alarms, aeration systems, and backup pumps and generators.

## 7.5.3 Pickets

Pickets are used to prevent fish from entering a specific area (e.g., AWS) or to guide fish to a particular area (e.g., toward a counting window for enumeration or a trap entrance).

### 7.5.3.1 Design velocity

*The average velocity through pickets should be less than 1 ft/s for all flows (Clay 1995).*

The average design velocity is calculated by dividing flow by the total submerged picket area. Non-uniform or excessive velocities through the structure can create false attraction conditions that delay fish and induce upstream migrants to attempt to jump over the pickets, potentially injuring the fish.



### **7.5.3.2 Material**

*Pickets should be constructed of non-corrosive materials. Panels may consist of flat bars (where the narrow edge of the bar is aligned with flow) or round columns of steel, aluminum, or durable plastic. All surfaces exposed to fish should be rounded or ground smooth to the touch, with all edges aligning in a single smooth plane to reduce the potential for contact injury.*

### **7.5.3.3 Bar spacing**

*The maximum clear spacing between picket bars is 1 inch for adult trapping facilities. At sites where lamprey may be present, pickets should have a maximum 0.75-inch clear spacing between bars.*

At sites where smaller fish are present, a smaller spacing between bars may be required.

### **7.5.3.4 Pickets in off-ladder holding pools**

*Off-ladder holding pools should include intake and exit pickets designed to prevent adult fish from exiting the holding pool. These should conform to the criteria identified in Section 6.3. The design of off-ladder holding pools should also include an adjustable overflow weir located downstream of, or in conjunction with, the entrance pickets to control the water surface elevation in the holding pool.*

### **7.5.3.5 Blocking pickets**

*Removable pickets installed within the ladder to block fish from ascending further and route them into an off-ladder trapping pool should be angled toward the off-ladder trap entrance and comply with the criteria listed in Sections 5.3.7 and 5.6.3.7. Pickets installed within ladders should be completely removed from the ladder when trapping activities are not occurring.*

## **7.5.4 Trapping Mechanisms**

### **7.5.4.1 Description and purpose**

*There should be a mechanism that allows fish to enter, but not volitionally exit, a holding pool. The most commonly used mechanisms include finger weirs, Vee trap fykes, or false weirs (Section 7.5.8).*

*The maximum velocity over finger traps is 8 ft/s. The amount of flow over the top of a finger weir is usually 2 to 6 inches but varies based upon species. The height of a finger weir varies but is usually in range of 6 to 10 inches (Bell 1991). When using finger traps, an escape area should be provided at both ends to prevent fish from being held against the fingers and killed (Bell 1991).*

*For a Vee trap, Bell (1991) recommends a minimum velocity of 4 ft/s. The opening at the apex is usually around 8 inches but may need to be larger or smaller depending upon the species present. Being able to adjust this opening can be very beneficial.*

Figure 7-1 shows a schematic of a finger weir. Figure 7-2 shows a cutaway of a Vee trap.

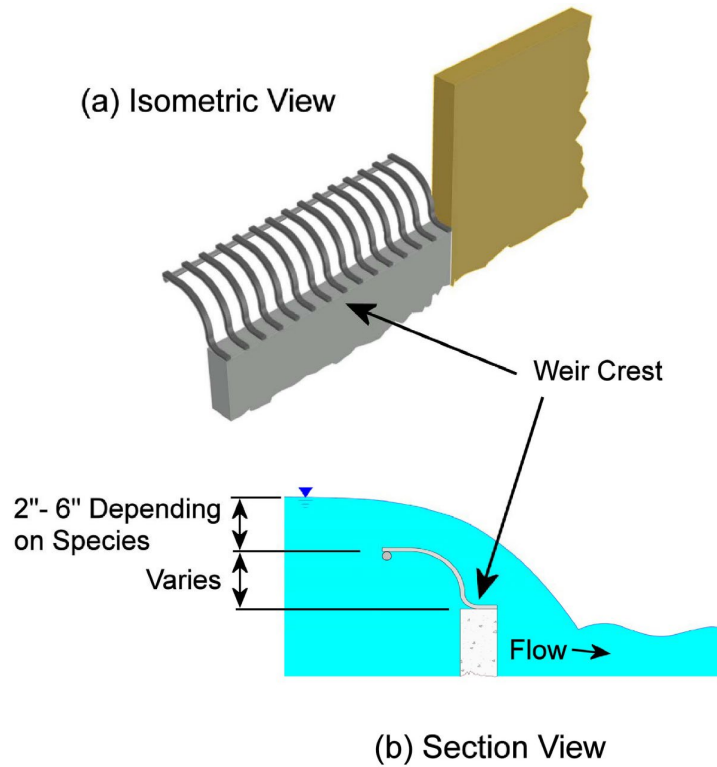

Figure 7-1. Finger weir schematic

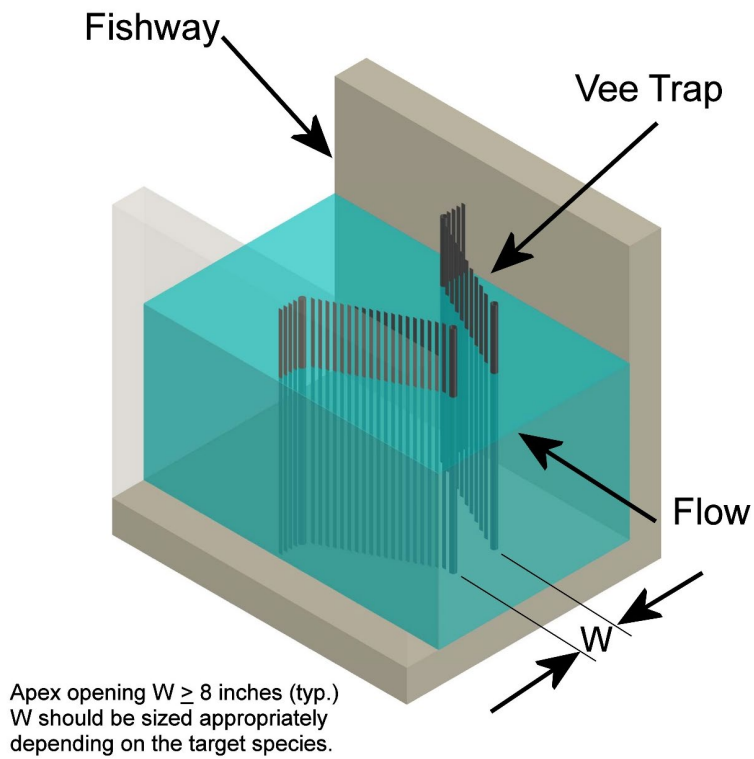

Figure 7-2. Cutaway of a Vee trap

#### **7.5.4.2 Edges**

*All trapping components exposed to fish should have all welds and sharp edges ground smooth to the touch to minimize injuries. Additional features, such as neoprene padding (covered by UV stabilized rubber), may also be required to minimize fish injuries.*

#### **7.5.4.3 Materials and bar spacing**

*Materials and bar spacing should conform to Sections 7.5.3.2 and 7.5.3.3.*

#### **7.5.4.4 Closure**

*Trapping mechanisms should be able to be closed temporarily to avoid spatial conflict with trail crowding and loading operations. The trapping mechanisms should be designed to safeguard against fish gaining access to unsafe areas such as areas behind a crowder or under a floor trail.*

### **7.5.5 Holding Pools**

Holding pools and raceways are used to provide safe areas where fish can be held and accumulated until the facility operators are prepared to process them (for actions such as sorting, evaluation, or transportation).

#### **7.5.5.1 Water quality**

*Holding pool water quality should be equal to or exceed that of the ambient waters from which fish are trapped.*

Key water quality parameters include water temperature, oxygen content, and pH. The purpose of this criterion is to provide fish with a safe, healthy holding environment.

#### **7.5.5.2 Trap holding pool capacity**

The following criteria should be followed with regard to trap holding pool capacity:

- *Trap holding pool capacity is based on the number and poundage of fish that can be safely held in a given pool volume for a given time period as well as water quality and quantity.*
- *The number of fish is determined by the maximum daily number of fish passing through the ladder or facility, or by the number of fish expected to be trapped and held prior to being transported.*
- *Fish poundage is determined by multiplying the weight of the average fish targeted for trapping by the maximum number of fish expected to occupy the trap. Note that the poundage calculation may entail calculations for a number of different fish species.*

#### **7.5.5.3 Short-term holding**

*Trap holding pools should be sized to provide a minimum volume of 0.25 ft<sup>3</sup>/lb of fish. Trap water supply flow rate should be at least 0.67 gallon per minute (gpm) per adult fish for the predetermined adult fish trap holding capacity.*

These criteria apply to conditions when water temperatures are less than 50 degrees Fahrenheit (°F), dissolved oxygen is between 6 and 7 parts per million, and fish are held less than 24 hours (Senn et al. 1984; Bell 1991; Bates 1992). For example, to hold 100 lb of fish for less than 24 hours, the holding pool would need to provide a volume of 25 ft<sup>3</sup> (100 lb × 0.25 ft<sup>3</sup>/lb of fish) at 50°F. These criteria are based on the long-term holding requirements presented by Senn et al. (1984), which have been modified and adapted to short-term holding conditions. (See Section 7.5.5.5 for guidance on when water temperatures exceed 50°F.)

#### 7.5.5.4 Long-term holding

*Trap holding pool water volumes and water supply rates should be increased by a factor of 2 (0.5 ft<sup>3</sup>/lb of fish and at least 1.34 gpm per adult fish, respectively).*

For example, to hold 100 lb of fish for more than 24 hours (but less than 96 hours), the holding pool would need to provide a volume of 50 ft<sup>3</sup> (100 lb × 0.5 ft<sup>3</sup>/lb of fish) at 50°F. Long-term holding should not exceed 96 hours. Trap and haul facilities are not intended for the long-term holding of adults (e.g., hatchery broodstock). However, NMFS will consider additional information or research regarding adult fish holding times and densities, if provided. (See Section 7.5.5.5 for guidance on when water temperatures exceed 50°F.)

#### 7.5.5.5 Holding pool capacity when water temperatures are greater than 50°F

*If water temperatures are greater than 50°F, the poundage of fish held should be reduced by 5% for each degree above 50°F (Senn et al. 1984). The trap capacity and average weight of targeted fish values to be used in a design are subject to approval by NMFS.*

*For short term holding (less than 24 hours) at 60°F, to hold 100 lb of fish, the holding pool would need to provide a volume of 50 ft<sup>3</sup>. For long term holding (greater than 24 hours but less than 96 hours) at 60°F, the holding pool would need to provide a volume of 100 ft<sup>3</sup>.*

*Extreme care should be taken when water temperatures are above 68°F during trap operations.*

Table 7-1 is provided for reference.

**Table 7-1. Holding Pool capacity when water temperature exceeds 50°F**

Temp (°F)	Short Term Holding (0.25 lb/ft <sup>3</sup> )	Short Term Holding (0.25 ft <sup>3</sup> /lb)	Long Term Holding (0.5 lb/ft <sup>3</sup> )	Long Term Holding (0.5ft <sup>3</sup> /lb)
50	4.00	0.25	2.00	0.50
51	3.80	0.26	1.90	0.53
52	3.60	0.28	1.80	0.56
53	3.40	0.29	1.70	0.59
54	3.20	0.31	1.60	0.63
55	3.00	0.33	1.50	0.67
56	2.80	0.36	1.40	0.71

57	2.60	0.38	1.30	0.77
58	2.40	0.42	1.20	0.83
59	2.20	0.45	1.10	0.91
60	2.00	0.50	1.00	1.00
61	1.80	0.56	0.90	1.11
62	1.60	0.63	0.80	1.25
63	1.40	0.71	0.70	1.43
64	1.20	0.83	0.60	1.67
65	1.00	1.00	0.50	2.00
66	0.80	1.25	0.40	2.50
67	0.60	1.67	0.30	3.33
68	0.40	2.50	0.20	5.00
69	0.20	5.00	0.10	10.00

#### 7.5.5.6 Trap holding pool inflow

The following criteria should be followed with regard to trap holding pool inflow:

- *Inflow should be routed through an upstream diffuser designed in accordance with the criteria identified in Section 5.3.7.*
- *The maximum average velocity through the diffuser that is acceptable is 1 ft/s for vertical diffusers and 0.5 ft/s for horizontal diffusers.*
- *Horizontal diffusers should be used when supplying water directly to fish holding pools to reduce the potential for fish jumping at the diffuser flow (Bell 1991).*
- *For both vertical and horizontal diffusers, baffling and other methods of energy dissipation should be used to prevent excessive turbulence and surging, which may induce adult jumping within the trap.*
- *Flow distribution through the diffuser should not cause fish to crowd into a particular area of the holding pool. However, when fish are being crowded for handling or routing, it is best to take advantage of their natural behavior and concentrate the water supply near the end of the pool where fish are being encouraged to move to as part of the operation.*

#### 7.5.5.7 Shading

*Consideration should be given to providing shading for holding pools and raceways.*

Shading can reduce stress and jumping in adult fish and can reduce the potential for sun burn (Bell 1991).

#### 7.5.5.8 Holding pool water depth

*The minimum depth of water in the holding pool is 5 feet.*

This is the same minimum depth criterion as is specified for fish ladder pools.

### **7.5.5.9 Adult jumping**

*Trap holding pool designs should include provisions that minimize adult jumping, which may result in fish injury or mortality.*

Examples of provisions that reduce jumping include the following (Bell 1991):

- Incorporating a high freeboard on holding pool walls of 5 feet or more (note that Bell [1991] recommends incorporating up to 6 feet of freeboard into the facility design)
- Covering or shading the holding pool to keep fish in a darkened environment
- Providing netting over the pool that is strong enough to prevent adults from breaking through the mesh fabric
- Providing sprinklers above the holding pool water surface to break up the water surface and reduce the ability of fish to detect movement above the trap pool
- Designing the corners of the holding pools to have a minimum radius of 18 inches
- Ensuring that water from distribution flumes and pipes does not drop directly into the holding pool
- Ensuring that there are no areas of strong horizontal light nor dark areas present on the surface of the holding pool

## **7.5.6 Crowders**

Crowders are porous panels that can be deployed into a holding pool and used to move fish horizontally to the end of the pool for collection by a hopper or lift, or to encourage the fish to leave the holding pool. Crowders can be pushed by personnel or mechanically operated.

### **7.5.6.1 Bar spacing**

*Holding pool crowders should have a maximum clear opening between bars of 0.875 inch. Gaps around the sides of crowder panels should not exceed 1 inch. The side and bottom seals of the crowder panel should allow the crowder to move without binding and should prevent fish from entering the area behind the crowder panel.*

*If smolt-sized juvenile salmonids or other small fish are expected to be retained in the adult holding pool, the maximum clear bar spacing of the crowder panel (and brail if present) should be reduced to 0.25 inch, and any gaps around the sides the crowder panels should not exceed 0.375 inch.*

Often, smaller-sized fish find their way into and become caught in the adult trap holding pool. Provisions should be incorporated into the trap design to safely remove smaller-sized fish from the holding pool and return them to the river.

### **7.5.6.2 Material**

*Crowder panels should be constructed of non-corrosive materials. The use of galvanized material should be avoided if possible, and otherwise minimized. Panels may consist of fish screen material such as profile bar or perforated plate material, flat bars where the narrow edge*

*of the bar is aligned with flow, or round columns of steel, aluminum, or durable plastic. All edges and surfaces exposed to fish should be rounded or ground smooth to the touch.*

The galvanization process uses zinc, which can be toxic to fish (this is why non-corrosive materials for crowder panels should be used). During the crowding process, fish are extremely likely to come into direct contact with the crowder panels. To reduce the potential for fish to be descaled or injured when being crowded, all surfaces and edges that fish can contact need to ground smooth or rounded.

### **7.5.6.3 Crowding process and crowding speeds**

*For mechanical crowders, the beginning of the crowding process can be automated, but at the end of the process when fish densities are high the crowder should be manually controlled.*

*Speeds for horizontally oriented crowders are typically in the 0.5- to 1-ft/s range for pre-anesthesia, sorting, and holding pools. Maximum crowder speed should not exceed 2 ft/s and should be adjustable.*

Crowders are often controlled by a variable frequency drive (VFD). VFDs allow for crowder travel speed to be slowly increased or decreased. This moves the equipment to crowd, but not stress, adult fish in the holding pool. Further, it eliminates erratic (jerking) crowder movement provided with a simple on-off switch. Crowder speeds are also sometimes controlled by a switch to toggle between fast and slow speeds. In all cases, the VFD should be programmed not to increase the crowder or rail speed beyond a maximum level.

### **7.5.6.4 Coverage**

*Crowders should be able to cover (crowd) the entire holding pool and should not leave any areas where fish may escape the crowding process.*

Being able to crowd the entire holding pool ensures that all fish can be removed from the pool and that no fish spends more time than necessary in the holding pool.

### **7.5.6.5 Fish entering the holding pool while crowding**

*If the crowder cannot be removed from the holding pool, it is important that fish do not enter that portion of the holding pool located behind the crowder during crowding operations.*

Fish should not be able to access the area behind the crowder where they could become trapped resulting in injury or death.

## **7.5.7 Brails**

Brails are porous panels that can be used to move fish vertically in a holding pool or fish lock. For large holding pools, they are often used in conjunction with a crowder to encourage fish to exit the holding pool.

### **7.5.7.1 Floor brails**

The following criteria should be followed with regard to floor brails:

- *Floor brails should be composed of screen material that is sized according to the life stage and species present to preclude injury or mortality from occurring to target and non-target fish species. Gap openings along the sides of the brail should not exceed 1 inch.*
- *For adult salmonids, brails should have a maximum clear spacing between bars of 0.875 inch. Gaps around the sides of crowder panels should not exceed 1 inch, and seals should be installed that cover all gaps. The side and bottom seals of the crowder panel should allow the crowder to move without binding and prevent fish from moving underneath the brail.*
- *If juvenile salmonids (i.e., smolt-sized fish) or other small fish are expected to be caught in the holding pool, consideration should be given to including a separator system and juvenile sanctuary area as part of the brail system. Also, the maximum clear spacing between bars of the brail should be reduced to 0.25 inch, with side tolerances of no more than 0.375-inch opening or the openings sealed with a brush material.*

### **7.5.7.2 Material**

*Brail panels should be constructed of non-corrosive material. The use of galvanized material should be avoided if possible, and otherwise be minimized. Panels may consist of fish screen material such as profile bar or perforated plate material; flat bars where the narrow edge of the bar is aligned with flow; or round columns of steel, aluminum, or durable plastic. All edges and surfaces exposed to fish should be rounded or ground smooth to the touch.*

The galvanization process uses zinc, which can be toxic to fish (this is why non-corrosive materials for crowder panels should be used). During the crowding process, fish are extremely likely to come into direct contact with the crowder panels. To reduce the potential for fish to be descaled or injured when being crowded, all surfaces and edges that fish can contact need to ground smooth or rounded.

### **7.5.7.3 Slope**

*The sides and the floor of the brail should be sloped toward the holding pool egress point to encourage adult fish to move off the brail.*

### **7.5.7.4 Lifting**

*The brail should not be used to lift fish out of the water.*

### **7.5.7.5 Brail speed**

*Brail speeds are typically in the 0.5- to 1-ft/s range for pre-anesthesia, sorting, and holding pools. Maximum brail speed should not exceed 2 ft/s and should be adjustable. The beginning of the brailing process can be automated, but at the end of the process when fish densities are high, the brail should be manually controlled.*



### 7.5.7.6 Fish lock brails

When floor brails are used in association with fish locks (Section 7.6.2), the floor brail hoist should be designed for both manual and automatic operation and should allow the brail to move at a maximum rate of 2.3 ft/s (both upward and downward). Also, the brail should be able to be operated at speeds that match changes in water surface elevation. Automated operation is allowed only when the water depth above the brail is 4 feet or more. At water depths less than 4 feet, operation of the brail should be conducted manually.

These criteria are designed to minimize stressing fish during crowding between the floor brail and the point where water in the lock exits over an egress weir.

### 7.5.8 False Weirs

A false weir is a specialized floor diffuser used to introduce water at the top of a fishway or entrance to a distribution flume for the purpose of attracting and encouraging fish to voluntarily move into a specific area (Figure 7-3). The device usually creates a strong upwelling flow that simulates flow cascading over a weir. Fish are attracted to the cascading flow and swim through the upwelling into the distribution flume. Care should be taken when locating a false weir to avoid light-to-dark transition at the location of the false weir (shadows) or movement by operator personnel around the false weir. These conditions could cause a fish to reject (not enter) the false weir.

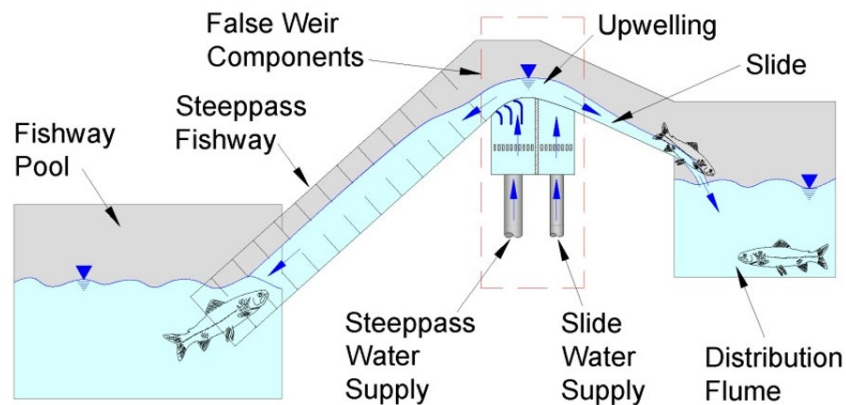

Figure 7-3. Cross section of a false weir

#### 7.5.8.1 Depth

Water depth over the crest of the false weir should be at least 6 inches to facilitate fish egress from the holding pool.

#### 7.5.8.2 Water Supply and Dewatering

The false weir design should include independent water control for both the weir side (steeppass water supply side in Figure 7-3) and flume side (slide water supply in Figure 7-3). Additionally, the slide side of the false weir should include a dewatering screen/system to allow the operator to trim the flow down the slide/flume.

Tuning the amount of flow over the false weir to encourage fish movement while having the ability to limit the amount of flow down the flume is very important. Too much flow down the flume, may allow the fish to try to swim against the flow until exhaustion (Section 7.5.9.3). Achieving the balance between sufficient weir flow and reduced flume flows can be impossible with a common water supply. The addition of a drain between the weir supply and the flume supply is very helpful and allows the operator to maximize attraction flow entering the holding pool. Finally, the independent water control and drain allows the operator to continue to supply the flume with flow both before and after the weir is turned on and off, respectively.

### **7.5.8.3 Adjustability**

*The false weir and the downstream water level should have enough adjustability to backwater the false weir and create a streaming flow condition, rather than a plunging flow condition over the weir.*

Incorporating this adjustability in the design of the false weir allows the operator to adjust conditions at the false weir to allow adult fish to swim through the weir, rather than having to leap at it to pass the weir. Care should be taken when raising the downstream water surface elevation to ensure this does not adversely affect hydraulic conditions in the trap facility further downstream of the false weir.

### **7.5.8.4 Fish entering a distribution flume**

*In situations where fish are entering a distribution flume after passing over a false weir, the ability to change the amount of flow coming from the false weir should be rapid and easy to change in order to regulate the movement of fish over the weir.*

Oftentimes it is necessary to control (i.e., meter) the number of fish passing through the false weir so operator personnel can identify and sort fish into various holding tanks. Having the ability to rapidly change the amount of flow coming from the false weir allows the operator some control over how many fish enter the false weir at time. Operator-controlled neoprene doors that open and close in front of, or vary the width of, the entrance to the false weir can be used to allow the operator to more efficiently meter fish through the false weir. Care should be taken in providing sufficient freeboard (around, above, through and downstream of the false weir), since very strong leapers (like steelhead) can jump much higher than the water level on the weir crest.

### **7.5.8.5 Edges**

*Provisions, such as neoprene padding (covered by UV stabilized rubber), should be installed around a false weir to protect fish that make an inaccurate leap at the weir from being injured.*

### **7.5.8.6 Gravity flow**

*A gravity flow (i.e., not pumped) water supply should be used for false weirs and steep pass ladders to prevent fish from potentially rejecting the trap component due to the production of noise or vibration from a pump or motor. At sites where it is necessary or*

*desirable to use a pumped water supply, care should be taken to isolate the pump noise and vibration from affecting the fish.*

## **7.5.9 Distribution Flumes and Pipes**

### **7.5.9.1 General**

*A distribution flume (or pipe) should be used whenever fish are routed from one area to another.*

Distribution flumes are used to convey fish to anesthetic tanks, recovery tanks, pre-transport holding tanks, fish ladders, and project forebays. They are also used to convey fish to various locations after they pass through false weirs.

### **7.5.9.2 Smoothness**

*The flume should have smooth joints, sides, and bottom, with no sharp or abrupt edges and no abrupt vertical or horizontal bends.*

### **7.5.9.3 Wetted surfaces, water depth, and velocity**

The following criteria should be followed with regard to wetted surfaces, water depth, and velocity:

- *The flume should have continuously wetted surfaces.*
- *For flumes less than 50 feet in length, water depth in the flume should be between 1 and 3 inches, and water velocity should be between 6 and 8 ft/s.*
- *For flumes that are longer than 50 feet, a closed pipe with open channel flow should be used for the entire length of the flume. The water depth in the pipe should be between 2 and 4 inches (a depth of 4 inches is preferred), and water velocity should be greater than 8 ft/s, but less than 15 ft/s.*
- *Site-specific adjustments to these values may be required.*

The combination of low water depth and high velocity is intended to prevent adult fish from holding in the pipe or swimming upstream in the pipe. If the pipe is above ground, observation ports with removable covers should be provided so that conditions in the flume can be observed and the pipe can be accessed for maintenance and debris removal. If the pipe is located belowground, access ports should be provided for inspection and maintenance.

### **7.5.9.4 Outfalls**

*When distribution flumes lead to holding tanks or raceways, care should be taken so that adults entering the tank do not hit the walls, floor, or end of the tank or collide (land on top of) with other fish. A dewatering drain should be located immediately upstream of the outfall to eliminate flow from the outfall which can cause false attraction and jumping.*

*When a distribution flume is used to return adults to the river, the criteria for juvenile outfalls (Section 8.6.4) should be followed (i.e., the bypass flow should not impact the river*

*bottom or other physical features at any stage of river flow, and the maximum bypass outfall impact velocity should be less than 25 ft/s).*

#### **7.5.9.5 Bends**

*Horizontal and vertical radii of curvature should be at least 5 times the width of the flume to minimize the risk of fish-strike injuries. A removable flume cover should be provided when flumes go through bends greater than 30 degrees in alignment.*

Removable covers are necessary to prevent active fish from leaping out of the flume and allow personnel to inspect the flume for debris accumulation in the bend.

#### **7.5.9.6 Size**

*The minimum inside diameter of the distribution flume should be 15 inches for fish weighing 20 lb or less and 18 inches for fish weighing 20 lb or more.*

*The minimum sidewall height of a distribution flume is 24 inches.*

This height is in addition to the radius of the flume. For example, the minimum total height of a 15-inch diameter flume would be 31.5 inches (24 inches plus half of the diameter at 7.5 inches), as measured from the invert of the flume.

#### **7.5.9.7 Length**

*Distribution flumes should be as short as possible.*

#### **7.5.9.8 Flume structure**

*Overhead structures that are part of the flume, such as overhead bracing to stiffen the walls of the flume or gate operation arms, should be eliminated if possible, or minimized. If overhead structures are necessary, they should be located above the top of the flume sidewalls or 30 inches above the invert of the flume, whichever is greater.*

### **7.5.10 Anesthetic Recovery Pools**

The following criteria should be followed with regard to anesthetic recovery pools:

- *Anesthetized fish should be routed to a recovery pool to allow the fish to be monitored prior to release to ensure they have fully recovered from the anesthesia.*
- *Fish that are recovering from anesthesia should not be routed directly back to the river where unobserved mortality may occur.*
- *Recovery pool inflow should satisfy the water quality guidelines specified in Section 7.5.5.*
- *Recovery pool hydraulic conditions should not result in partially or fully anesthetized fish being impinged on an outflow grating or any other hazardous area.*
- *A recovery pool should allow fully recovered fish to volitionally exit the pool.*
- *The recovery pool should have a brail or crowder system to force fish from the recovery pool if necessary.*

Often, fish require time to recover from effects of anesthetic. Anesthetized fish released directly to an uncontrolled environment (i.e., directly back to the river or into a ladder) often fail to orient themselves upright and sometimes sink to the bottom where they may suffocate or are swept downstream. It is important to provide fish recovering from anesthetic with a safe recovery area where they can be monitored by personnel. Some indications that fish are fully recovered include they are upright and oriented, display normal gilling activity, and are responsive to stimuli. If a fish appears to be struggling to recover or appears distressed, it may be necessary to retrieve the fish and revive it. Revival may involve manually ventilation of the gills by gently moving the fish forward and backward in the water. The ability of a fish to volitionally exit the recovery pool is an indication that the fish has recovered sufficiently from the anesthetic. Fish should not be forced out of the recovery pool for at least 30 minutes after exposure to anesthetic.

## **7.6 Lifting Devices**

Section 7.6 provides criteria and guidelines that apply to fish lifting devices.

### **7.6.1 Fish Lifts and Hopper Passage Systems**

A fish lift is a mechanical system that utilizes a hopper and hoist to allow fish to be trapped at one elevation and raised to a higher elevation. Once raised to the higher elevation, fish can be loaded into a transport tank or truck for release at a remote location, routed to a monitoring and sorting facility, or released above a dam directly into the forebay.

#### **7.6.1.1 Maximum hopper loading densities**

*The hopper water volumes should be greater than or equal to 0.15 ft<sup>3</sup>/lb of fish estimated to occur at the maximum fish load. When large fish (fish ranging from 30 to 40 lb in weight) are being transported, the poundage being transported should be reduced by 50% (Bell 1991).*

Hopper loading densities are designed to ensure that a sufficient volume of water is available to fish to be raised safely. Normally, the size of the hopper and transport tank loading match, such that a full hopper volume equals a full transport tank volume. The density of fish being held when water temperatures become elevated is a concern that needs to be considered. Bell (1991) recommends that the poundage of fish being transported in tanks be reduced by 10% for each degree of water temperature above 60°F.

#### **7.6.1.2 Hopper freeboard**

*The distance from the water surface in the hopper to the top of hopper bucket should be greater than the water depth within the hopper.*

This is to reduce the risk of fish jumping out of the hopper during lifting operations.

#### **7.6.1.3 Sump**

*When a trap design includes a hopper sump into which the hopper is lowered during trapping, side clearances between the hopper and sump sidewalls should not exceed 1 inch to*

*minimize access to the area below the hopper. Flexible side seals or brushes should be used to ensure that fish do not pass below the hopper.*

It is very important that the hopper and gates around the sump provide a positive seal and do not allow fish to get into the sump area. If fish do get into this area, they can be very difficult to remove due to the water depth and confined area.

#### **7.6.1.4 Fish hopper egress opening**

*The fish egress opening from the hopper into the transport tank should have a minimum horizontal cross-sectional area of 3 square feet and a smooth transition to minimize the potential for fish injury.*

#### **7.6.1.5 Safeguarding fish**

*Fail-safe measures should be provided to prevent fish entering the holding pool area from accessing the area occupied by the hopper before the hopper is lowered into position. The interior surfaces of the hopper should be smooth to eliminate fish injuries.*

### **7.6.2 Fish Lock**

A fish lock is a mechanical-hydraulic system that utilizes a water chamber or tower to raise fish from one elevation to another. It allows fish that are collected (trapped) at a lower elevation to be raised to a higher elevation by increasing the water level in the chamber or tower until it reaches a predetermined elevation where fish can be released. The fish can be brailed (i.e., crowded) to the higher elevation and then loaded into a transport truck for release at a remote location, routed to a monitoring and sorting facility, or released directly above a dam into the forebay (Clay 1995).

Section 7.6.2.1 outlines the process for routing fish from a holding pool to the forebay or transport vehicle using a fish lock.

#### **7.6.2.1 Holding pool crowding**

The following criteria and guidelines should be followed with regard to holding pool crowding:

- *Fish are crowded into the lock; the crowder should meet up with the entrance to the lock so that no fish can become trapped or crushed between the crowder and the lift structure or closure gate.*
- *When the closure gate to the fish lock chamber is shut it should create a uniform surface with the interior of the lock so that the brail can pass the gate without creating excessive gaps that could allow fish to get past the brail.*
  - *The closure gate is the gate that seals the lock chamber from the holding pool.*
- *Once the closure gate is shut, the crowder should be backed up to reduce the stress on the fish.*

- Crowding, especially the last part of the crowd when fish are forced from the holding pool, can be very stressful to the fish. If there is a break in the crowding operation for some reason (lifting and operating the hopper for example), the crowder should be backed off to reduce the stress on the fish.
- *Flow to fill the lock should be introduced into the lock through floor diffusers below the floor brail.*
  - As the water level rises within the lock, it will ultimately reach an equilibrium elevation with a control weir or false weir.
- *The floor brail should be raised only after the water surface elevation in the lock is at an equilibrium with the control weir or false weir. If the brail is being operated while the fish lock is being filled, the speed of the brail should not exceed the rate of change in water surface elevation. The brail should be greater than 4 feet from the water surface until the water level reaches equilibrium with the control or false weir. The brail should not be used to lift fish out of the water (Section 7.5.7.4).*
  - Speeds for brails (vertically oriented crowders) are typically in the 0.5- to 1-ft/s range for pre-anesthesia, sorting, and holding pools, but can range up to 2.3 ft/s for vertical fish locks.
- *Fish should exit the lock via a false weir or through the overflow water draining over the control weir.*
- *Fish and water that pass over the control weir or false weir can be routed using a distribution flume to other destinations, including an anesthetic tank, sorting or holding pools, or a transportation vehicle.*
  - Floor dewatering screens in the distribution flume can be used to drain off excess flow just before fish are delivered to anesthetic tanks, holding pools, or transportation vehicles.

#### **7.6.2.2 Lock inflow chamber**

*The lock inflow chamber located below the lowest-floor brail level should be of sufficient depth and volume (Section 5.5.3.5) to limit turbulence into the fish holding zone when lock inflow is introduced. The inflow sump should be designed so that flow upwells uniformly through add-in floor diffusers (Section 5.3.7; Bell 1991).*

Properly designed lock inflow chambers will limit turbulence and unstable hydraulic conditions within the lock that may agitate fish.

### **7.7 Single Holding Pool Traps**

Single pool traps are often used in tandem with intermittent exclusion barriers (Figure 6-5) for broodstock collection from small streams. These trapping systems are used to collect, sort, and load adult fish. Key criteria for single holding pool traps are as follows:

- *The trap holding pool water volume should be designed according to Section 5.5.3.5 to achieve stable interior hydraulic conditions and minimize jumping of trapped fish.*
- *Intakes should conform to Section 5.3.2.*

- *Sidewall freeboard should be a minimum of 4 feet above the trap pool water surface at high design streamflow.*
- *The trap holding pool interior surfaces should be smooth to reduce the potential for fish injury.*
- *A description of the proposed means of removing fish from the trapping pool and loading them onto a transport truck should be submitted to NMFS for approval as part of the ESA incidental take permit application.*

## **7.8 Upstream Transportation Criteria**

Section 7.8 provides criteria and guidelines that are applicable to truck transportation equipment and facilities.

### **7.8.1 Maximum Transport Tank Loading Densities and Time**

*Transport tank loading water volumes should be greater than or equal to 0.15 ft<sup>3</sup>/lb of fish at the maximum fish loading density to provide a sufficient volume of water for fish safety. When large fish (fish ranging from 30 to 40 lb in weight) are being transported, the poundage being transported should be reduced by 50% (Bell 1991). Every effort should be made to reduce the amount of time fish spend in a transport tank.*

These loading densities are to ensure that a sufficient volume of water is available in the tank for fish to be transported safely. Normally, the size of the hopper and transport tank loading match, such that a full hopper volume equals a full transport tank volume. The density of fish being held when water temperatures become elevated is a concern that needs to be considered. Bell (1991) recommends that the poundage of fish being transported in tanks be reduced by 10% for each degree of water temperature above 60°F.

Due to the high loading densities in transport tanks and the stress it may create, every effort should be made to minimize the amount of time the fish spend in these tanks. Fish should not be held for long in a transport tank while waiting for other fish to be processed or while waiting for other fish to fill the tank.

### **7.8.2 Transport Tanks**

*To minimize handling stress, truck transport tanks should be compatible with the hopper design. If an existing vehicle will be used, the hopper should be designed to be compatible with existing equipment. If the transport tank opening is larger than the tube or hopper opening, a cap or other device should be designed to prevent fish from jumping at the opening. Truck tanks for hauling adults should be closed systems, and the tanks should be kept full to prevent sloshing (Bell 1991).*

#### **7.8.2.1 Fish transfer from hopper to tank**

*The transfer of fish should be made water-to-water. The design of the hopper and transport tanks should allow for hopper water surface control to be transferred to the truck*



*transport tank during loading so that water and fish do not plunge abruptly from the hopper into the fish transport tank.*

#### **7.8.2.2 Transport tank egress**

*The fish egress opening from the transport tank should have a minimum cross-sectional area of 2 square feet (Clay 1995). The bottom of the transport tank should be sloped (front to back and side to side) toward the release opening and have a smooth transition that minimizes the potential for fish injury.*

#### **7.8.2.3 Oxygen and temperature requirements**

*Depending upon site-specific conditions, the transportation tank should have the capability to maintain dissolved oxygen levels between 6 and 7 parts per million. The transportation tank should also contain water chillers to maintain ambient water temperature if the transport cycle time could result in unhealthy increases in the water temperature in the tank or temperature differential between the tank water temperature and the ambient water temperature where the fish are released exceed the water tempering described in Section 7.8.3.5.*

Many existing fish transport trucks do not include water chillers because they are designed for short transport trips during which the water temperature conditions in the tank do not result in temperature changes that exceed the water tempering requirements when the fish are released. Water tempering can be performed using chillers or mixing with cooler or warmer water at loading or release sites.

### **7.8.3 Release Location**

*After being transported, fish should be released in a safe location with sufficient depth and good water quality.*

The criteria and guidelines in Sections 7.8.3.1 through 7.8.3.6 apply to release locations.

#### **7.8.3.1 Direct release from a transport tank**

*Fish should not be dropped more than 6 vertical feet during release. The receiving water should be at least 3 feet deep, and fish should not contact the bottom. The impact velocity of fish entering the receiving water should be less than 25 ft/s.*

#### **7.8.3.2 Release pipe from a transport tank**

*For locations where release pipes are required, the minimum diameter for a release pipe is 24 inches (30 inches is preferred). The end of the release pipe should not be submerged. The internal surface of the pipe joints should be smooth to the touch to prevent descaling and injury to fish. The release pipe elevation criteria, receiving water depth, and impact velocity are the same as for fish being released directly from a transport tank (Section 7.8.3.1).*

Depending on how fish are released from the transport tank, the entrance to the release pipe may have to be larger (e.g., 36 inches), or a funnel or flume should be created that smoothly

transitions from the release tank outlet to the release pipe. Care should be taken to minimize the possibility of a fish leaping out of the system during transfer from the tank to release pipe.

#### **7.8.3.3 Release water**

*Water should be supplied to the release pipe prior to fish being released and also used to flush the last fish out of the pipe.*

#### **7.8.3.4 Water quality**

*Water quality (i.e., water temperature and dissolved oxygen) at the release site should be representative of the general water conditions in the river in the vicinity of the release site.*

#### **7.8.3.5 Water tempering**

*Fish should not be subjected to rapid temperature changes. Temperature differentials between the transport tank and release location should be no more than 2 degrees Celsius (°C). If tempering is required to meet this criterion, changes in temperature should not exceed 1°C every 2 minutes or 5°C per hour. Tempering may take longer when temperatures are further away from the optimal temperature for the target species and life stage.*

Changes in water temperature that occur too rapidly or are beyond the normal survival range of fish may cause thermal trauma (Post 1987). Mortality associated with rapid temperature changes may occur in the short term from loss of equilibrium (Bell 1991) and increased predation (Groot et al. 1995). Over longer time periods, thermal stress can act as an additive stressor and increase susceptibility to disease (Piper et al. 1982). Fish adapt more rapidly when the temperature change is nearer their thermal optimum than when the change is further away from that temperature (Schreck and Moyle 1990). Rapid changes in temperature have more significant negative effects at the upper end of a fish's temperature tolerance. As temperatures increase, fish are more active and have greater potential for self-inflicted injury, oxygen consumption is higher, and the saturation level of oxygen is lower, which increases the possibility of hypoxia (Murphy and Willis 1996).

#### **7.8.3.6 Release site egress**

*The release site should provide direct and simple egress for fish into the river for continued migration upstream.*

# 8 Fish Screen and Bypass Facilities

## 8.1 Introduction

Chapter 8 provides criteria for designing fish screen facilities for hydroelectric, municipal, irrigation, and other water-withdrawal projects that prevent fish (primarily young fish, fish with poor swimming capabilities, and larvae) from being entrained into water diversions. The objectives of these criteria are to develop fish screen facility designs that prevent fish impingement on the outward face of all fish screen material, do not increase predation above background levels, and ensure the structural integrity and longevity of all facility components is maintained. This allows the facility to be operated within its design criteria and protects fisheries resources over the design life of the project.

Striped Bass, Herring, Shad, Cyprinids, and other anadromous fish species may have eggs and/or very small fry which are moved with any water current (tides, streamflows, etc.). Installations where these species are present may require individual evaluation of the proposed project using more conservative screening requirements. In instances where state or local regulatory agencies require more stringent screen criteria to protect species other than salmonids, NOAA will consider deferring to the more conservative criteria on a case by case basis.

The criteria are to be used when designing new facilities or performing major retrofits to existing facilities. The criteria are also to be used for temporary diversions such as water drafting operations (Section 8.7) and when stream flow is to be routed around a construction site. In addition, information presented in Chapter 1, Introduction; Chapter 3, Design Development; and Chapter 4, Design Flow Range, of this document apply to the design of fish screen and bypass facilities.

### 8.1.1 100% Flow Screening

*All facilities that divert or use water from a body of water should convey 100% of the diverted flow through a fish screen or bypass that is designed, constructed, tested, and operated using the criteria contained herein.*

The application of these criteria to existing fish screen facilities is addressed in Section 8.2.

### 8.1.2 Deviation from These Criteria

*The criteria can be adjusted by NMFS as needed to meet the specific requirements of a project. It is the responsibility of the applicant to provide compelling evidence in support of any proposed waiver (Section 1.6) or modification of a criterion to NMFS early in the design process and well in advance of a proposed federal action. Appendix C (Experimental Technologies)*

*provides additional information on the NMFS approval process for unproven fish passage technologies.*

There may be cases where site constraints or extenuating circumstances weigh in favor of a deviation or waiver of these criteria. Extenuating circumstances may include environmental factors that affect a fish's swimming ability or condition such as abnormally warm or cold waters or waters low in dissolved oxygen.

The swimming ability of target fish species and their life stages are primary considerations in designing effective fish screen facilities. The swimming abilities of fish vary with species, age-class, size, and duration (i.e., endurance) and type of swimming activity required (e.g., sustained versus burst swim speed). Bell (1991) provides information on swimming speeds for multiple fish species and age-classes and for different functional speeds (cruising, sustained, and darting). Swimming ability also depends upon a number of biological and physical factors, including the physical condition of individual fish; water quality parameters, such as dissolved oxygen concentration and water temperature; and ambient lighting conditions. For example, swimming effort may be reduced by 60% at oxygen levels that are one-third of saturation, and temperatures above and below the optimum range for any species affect swimming effort (Bell 1991). Adverse temperatures may reduce swimming effort by 50% (Brett et al. 1958).

### **8.1.3 Experimental Technology**

*The process to evaluate experimental screening technology is described in Appendix C. Proponents of new, unproven fish passage designs (i.e., designs not meeting the criteria and guidelines contained in this chapter) should provide NMFS with the types of information identified in Section 1.5.*

NMFS considers several categories of screen designs that are currently in use to be experimental technologies. These include Eicher screens, modular inclined screens, and Coanda intake screens. Infiltration galleries may be considered an acceptable alternative for excluding fish at water diversions, but these are not considered positive exclusion barriers. Therefore, they are not addressed in this chapter. Information on the design and use of infiltration galleries is presented in Appendix B. The design and use of experimental technologies may be considered on a case-by-case basis through discussions with NMFS and in accordance with the procedures outlined in Appendix C.

## **8.2 Existing Fish Screens**

### **8.2.1 General**

*If a fish screen was constructed prior to the date of this document, but in accordance with the NMFS criteria that were established on August 21, 1989, or later, NMFS considers these screens to be compliant provided that all of the following conditions have been met:*

- *The entire screen facility functions and is operated as designed.*
- *The entire screen facility has been maintained and is in good working condition.*

- *When screen material wears out, it is replaced with screen material meeting the current criteria stated in this chapter (Section 8.5.8). To comply with this condition, structural modifications may be required to retrofit an existing facility with new screen material.*
- *Mortality, injury, entrainment, impingement, migration delay, or other harm to anadromous fish caused by the facility has not been observed.*
- *Emergent fry are unlikely to be located in the vicinity of the screen, as agreed to by NMFS biologists familiar with the site.*
- *When biological uncertainty exists, access to the diversion site by NMFS is permitted by the owner or operator of the facility for verification that the criteria in this chapter are being met.*

### **8.3 Project Design Review**

*The most effective approach to designing fish screening and bypass projects is to have NMFS included in all phases of the design. This can occur by having NMFS participate in a technical advisory team convened for the project or having NMFS review and comment on project designs, or both. While both the preliminary and final designs should be developed in cooperation and interaction with engineering staff from NMFS WCR Environmental Services Branch (Section 3.2), it is especially important that NMFS be involved in the preliminary design phase of a project. This is to ensure that the design parameters needed to produce a functional fish passage project are established early in the design process.*

The project design process is most efficient when design criteria are identified and accepted by NMFS while a project is in its infancy. The entire project design development process and information typically required for a preliminary design are discussed in Chapter 3.

### **8.4 Structure Placement**

*All screen facilities should be designed to function properly and protect fish from being entrained into the water diversion throughout the full range of hydrologic conditions expected to occur at the location.*

For in-stream facilities, the full range of conditions is normally from the minimum stream flow during which water diversions may take place, up to a 100-year flood event. In situations where streambanks will overtop allowing flow into the canal outside of the screen area at flows lower than the 100-year flood event, the screen may be designed to resist overtopping up to the lower flows. NMFS may require the facility operator to capture and relocate fish that become stranded behind a fish screen.

#### **8.4.1 In-Stream Installations**

*Where it is physically practical and biologically desirable to do so, the fish screen should be constructed at the point of water diversion, and the screen face should be oriented parallel to the streamflow.*

Several physical factors may preclude a fish screen from being located and constructed at the water diversion. These include excess channel gradient; the potential for large debris to

damage the screen facility; access for personnel and equipment to conduct facility maintenance, operations, and repair; unsuitable soils for constructing a fish screen facility at the point of diversion; and the potential for heavy sediment accumulations.

Depending on site-specific conditions, in-stream screens may be subject to increased damage by debris. However, they typically offer the following advantages:

- They do not require a formal bypass system.
- They keep migrating fish in the streamflow.
- They may reduce fish proximity to the screen face.

#### 8.4.1.1 Bankline screens

*For screens constructed at the edge of a stream (Figures 8-1 through 8-3), the screen face should be aligned with the adjacent bankline, and the transition between the native streambank and the fish screen face should be shaped to minimize turbulence and eddying in front, upstream, and downstream of the screen. For inclined, flat plate screen designs, the screen angle should not be greater than 45 degrees from vertical, and the top of the screen should be submerged a minimum of 1 foot at low stream design flow. The design should also minimize any adverse alteration of riverine and riparian habitat.*



**Figure 8-1. Aerial view of the Garden City-Lowden 2 water diversion on Walla Walla River near Touchet, Washington (Notes: River flow is from left to right. The bankline screen is located at the head end of the canal, just upstream of the spillway and adult ladder exit.)**





**Figure 8-2 Bankline screens at the Garden City-Lowden 2 diversion on the Walla Walla River near Touchet, Washington, under construction**



**Figure 8-3 Bankline vertical flat plate fish screen sized for 3,000 ft<sup>3</sup>/s (Glenn-Colusa Irrigation District) along the Sacramento River in California (Note: the screen is shown in operation (left) and during construction (right).)**

#### **8.4.2 In-Canal Installations**

*All screen facilities installed within canals should include an effective fish bypass system (Section 8.6) to collect and transport screened fish safely back to the river with minimum delay (Figure 8-4). In instances where the returned bypass flow represents a substantial proportion of the remaining instream flow downstream from the water diversion, the bypass outfall should be placed as close to the point of diversion as practicable to minimize the length of the dewatered stream channel.*

Where installation of fish screens at a diversion entrance is not desirable or is deemed impractical, the screens may be installed at a suitable location in the canal downstream of the water diversion. Locating the bypass outfall as close to the point of diversion as possible reduces the length of dewatered stream channel.

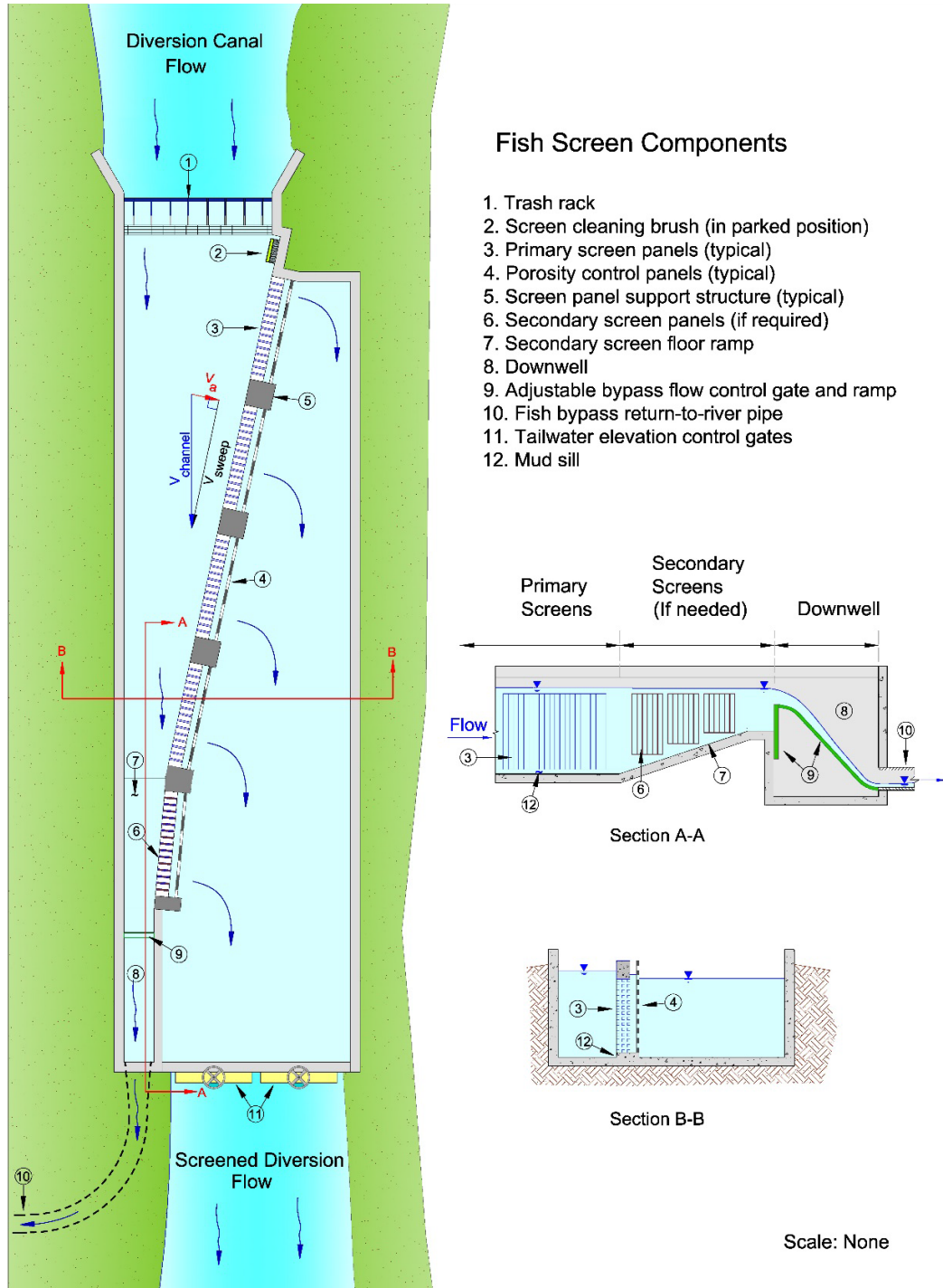

Figure 8-4 Schematic of a typical in-canal fish screen system layout and components at water diversions





**Figure 8-5 Vertical plate screen facility under construction in a diversion canal located on the Santiam River near Stayton, Oregon**

#### **8.4.2.1 Headworks Control Gates**

*Canal flow should be controlled with gates located downstream from the screen (Figure 8-4, tailwater control gates). If headworks gates must be used to throttle flow, they should not create a head differential greater than 12 inches. Submerged headworks control gates should be operated fully closed or open at least 12 vertical inches.*

Fish can be injured if forced to pass through a small opening created by a partially open headgate. Head drops greater than one foot through gates can prevent bidirectional movement of fish. Higher heads can create high water velocities and pressure differentials that may injure fish from shear stresses or impacts with hard surfaces.

#### **8.4.2.2 Headworks trash rack**

*All in-canal screens should have a trash rack at the canal headworks to minimize the amount of debris that will reach the fish screen structure (Bell 1991). Trash racks should have openings that are at least 10 inches wide for Chinook salmon passage and 8 inches wide for all other salmonid species.*

Additional trash rack design criteria are provided in Section 5.8 of this document. Bell (1991) recommends that openings be 12 inches wide for large salmon.

### **8.4.3 Lakes, Reservoirs, and Tidal Areas**

*Intakes in lakes, reservoirs, and tidal areas should be located offshore where feasible to minimize shoreline-oriented fish from coming into contact with the facility. When possible, intakes should be located in areas with sufficient ambient velocity to minimize sediment*

*accumulation in or around the screen. Intakes in reservoirs should be at an appropriate depth to reduce the number of juvenile salmonids that encounter the intake.*

The appropriate depth for intakes in lakes, reservoirs, and tidal areas will be determined on a case-by-case basis. One factor that will be considered when locating these intakes is that although juvenile salmonids are surface oriented, they may congregate in colder water located at depth if surface waters are too warm.

#### **8.4.3.1 Required submergence**

*For facilities in lakes, reservoirs, and tidal areas, the facility should be placed such that the screen area is adequately submerged to meet the design approach velocity criterion at the historical low water conditions (Section 8.5.7).*

## **8.5 Screen Design Specifications**

### **8.5.1 Approach Velocity**

*The design approach velocity for active screens should not exceed 0.4 ft/s for fish screens where exposure time is limited to less than 60 seconds, or 0.33 ft/s where exposure time is greater than 60 seconds (Smith and Carpenter 1987; Clay 1995). The design approach velocity for passive screens, as described in Section 8.5.6, should not exceed 0.2 ft/s (Cech et al. 2001).*

For the purposes of this document, approach velocity, “ $V_a$ ” in Figure 8-4, is defined as the water velocity component normal (perpendicular) to the screen surface. The minimum amount of screen area required is calculated by dividing the maximum diversion rate (in  $\text{ft}^3/\text{s}$ ) by the design approach velocity (in  $\text{ft}/\text{s}$ ). The porosity of the screen is not considered in the calculation of approach velocity. The operating approach velocity for any fish screen at any diversion rate may be calculated by dividing the current diversion flow rate by the effective screen area (Section 8.5.2).

Exposure time is defined as the time it takes a particle to traverse the length of the fish screen when moving at the speed of the sweeping velocity (Section 8.5.3). The design approach velocity criteria have been shown to minimize juvenile fish contact with, and impingement on, screen materials. This includes the impingement of emergent fry under cold water temperature conditions. (Appendix E provides a discussion of how to measure approach velocity.)

Note that these criteria apply to salmonids. Other species may require different approach velocity standards. For example, in California, the U.S. Fish and Wildlife Service requires that a design approach velocity of 0.2  $\text{ft}/\text{s}$  be used at locations where Delta smelt (*Hypomesus transpacificus*) are present.

### **8.5.2 Effective Screen Area**

*The effective screen area is defined as the total wetted screen area minus the area occluded by major structural elements. The minimum effective screen area required is defined as the maximum screen flow divided by the allowable approach velocity. For rotary drum screens,*

*the effective screen area is defined as the vertical projection of the wetted screen area minus the vertical projections of the area occluded by major structural elements.*

When calculating effective screen area, components (bars and rods) that make up the screen material are not considered to be “major structural elements” as long as the screen porosity remains greater than 27% when considering those structural elements. Major structural elements are elements of the facility that support the screen panels or cylinders.

### **8.5.3 Sweeping Velocity**

*The design sweeping velocities should never be less than the design approach velocity and should not decrease along the length of the screen.*

Sweeping velocity is defined as the water velocity component parallel to the face of a fish screen (Figure 8-4). A swift sweeping velocity may help move fish and debris past the fish screen and reduce the chance of impingement of juvenile salmonids on the screen material (Cech et al. 2001). Based on laboratory studies, (Cech et al. 2001) a high sweeping velocity (2 ft/s) minimized juvenile Chinook salmon contacts with screens during daylight conditions and maximized downstream passage during day and night conditions. Sweeping velocities between 0.8 and 3 ft/s are generally considered to be optimal. Higher sweeping velocities may be desired to prevent fish from swimming upstream out of the fish screen forebay.

#### **8.5.3.1 In-canal screens**

*In-canal screens should be angled across the canal to provide a sweeping velocity within the optimal range for the entire range of design conditions (Clay 1995). For screens shorter than 6 feet in length, the screen may be arranged perpendicular to canal flow. The sweeping velocity should remain constant or increase, but may not accelerate faster than 0.2 feet per second per foot (ft/s/ft) toward the bypass entrance.*

Studies show juvenile salmonids may resist entering a bypass system when encountering a sudden acceleration in water velocity (Haro et al. 1998). The acceleration criterion is designed to gradually guide fish toward and into the bypass entrance.

In some situations, angling of the screen for sweeping velocity optimization may best be accomplished using a vee-shaped arrangement, as shown in figure 8-5.

Brett and Alderdice (1953), as referenced in Clay (1995), recommend a uniform acceleration rate of no more than 0.1 ft/s/ft of length.

#### **8.5.3.2 On-river screens**

*Designers have less control over sweeping flow for screens built in a river or on the bank of a river; however, designers should make every attempt to ensure that sweeping velocity does not decrease along the length of the screen. This is to encourage fish to move past the facility and reduce the chance that sediment will deposit along the length of the screen.*

### 8.5.3.3 Quiescent and tidal areas

*To mitigate for a lack of sweeping velocity in quiescent and tidal areas, designers should use a design approach velocity not greater than 0.33 ft/s when calculating the effective screen area.*

Fish screens in lakes and tidal areas usually cannot meet the sweeping velocity criteria for in-canal or on-river screens. A lower approach velocity is required for these types of screens to allow fish to volitionally swim away from the screen face.

### 8.5.4 Flow Distribution

*The screen design should provide for nearly uniform flow distribution over the screen surface, thereby minimizing approach velocity over the entire screen face. The designer should demonstrate how a uniform flow distribution will be achieved. The maximum deviation from the target design approach velocity is 10%.*

Achieving a uniform flow distribution eliminates localized areas of high velocity that have the potential to impinge fish and debris. Methods that could be used to achieve uniform flow distribution include incorporating porosity control features on the downstream side of screens that can be adjusted and training walls to direct flow into the design. Large facilities may require hydraulic modeling to identify areas of flow distribution that are of concern to NMFS.

#### 8.5.4.1 Porosity controls

*To ensure uniform flow distribution, most screens should be equipped with some form of tunable porosity controls (i.e. baffles) placed immediately behind the screen. Screen porosity controls should be tuned to achieve approach velocity criteria at the earliest opportunity available. For screens greater than 10 feet tall, NMFS may require that the baffles be capable of controlling flow through the lower parts of screen panels independently of the upper parts. The use of louver-style porosity control baffles should be limited to flat plate screens 6 feet in height or shorter.*

A fish screen facility equipped with adjustable baffles to distribute flow uniformly over all wetted screen area is not considered complete until it undergoes a hydraulic evaluation to adjust the baffles. NMFS will determine one or more operating scenarios under which the hydraulic evaluation should take place. For most facilities, hydraulic evaluations should take place at or near the maximum diversion rate but there are cases where a lower diversion rate may be justified. In rare cases, a hydraulic evaluation may be required at two or more operating scenarios to account for various operating conditions such as, but not limited to, the following examples:

- A possible worst-case scenario for a fish screen may be when head waters are too low to submerge all screen area. In such cases, the fish screen hydraulics may need to be studied at a low water condition under a reduced diversion rate.
- At a high-water condition under the full diversion rate.
- At a low water condition under the full diversion rate.

The most common porosity control devices used to date have been louvers, where the angle of the louver can be varied to control the quantity of water flowing through the screen in front of the louver. However, it has been shown that it can be difficult to achieve uniform flow when using louver baffles (e.g., AECOM 2009). A newer method provides a more effective means of tuning screen velocity and flow distribution. It consists of sliding, overlapping porosity plates that are in contact with each other (Figure 8-6). As the moveable plate (vertically adjustable slotted plate; Figure 8-6) is adjusted, it obscures a progressively larger percentage of the perforations of the fixed plate (the stationary slotted plate; Figure 8-6). These panels (baffles) are typically installed in sections no greater than 2 feet wide, which provides fine-scale porosity adjustments for the screen as a whole. Porosity plates with square or slotted openings provide linear adjustability unlike porosity plates with circular openings (i.e., the change in porosity is linearly proportional to the distance the adjustable plate is moved). The adjustable and stationary slotted plates (parts 2 and 3, respectively, in Figure 8-6) should be of the same material or of different materials with similar coefficients of thermal expansion to maintain relative positioning over a range of temperatures. Ultra-high-molecular-weight (UHMW) polyethylene has a high coefficient of thermal expansion and should not be paired with aluminum or steel for this purpose. Using UHMW for both panels works well as the two sheets will slide easily and prevent leakage between sheets, but both panels should be manufactured under identical conditions to ensure holes align well. Metal panels may warp during fabrication which may prevent the panels from mating well.

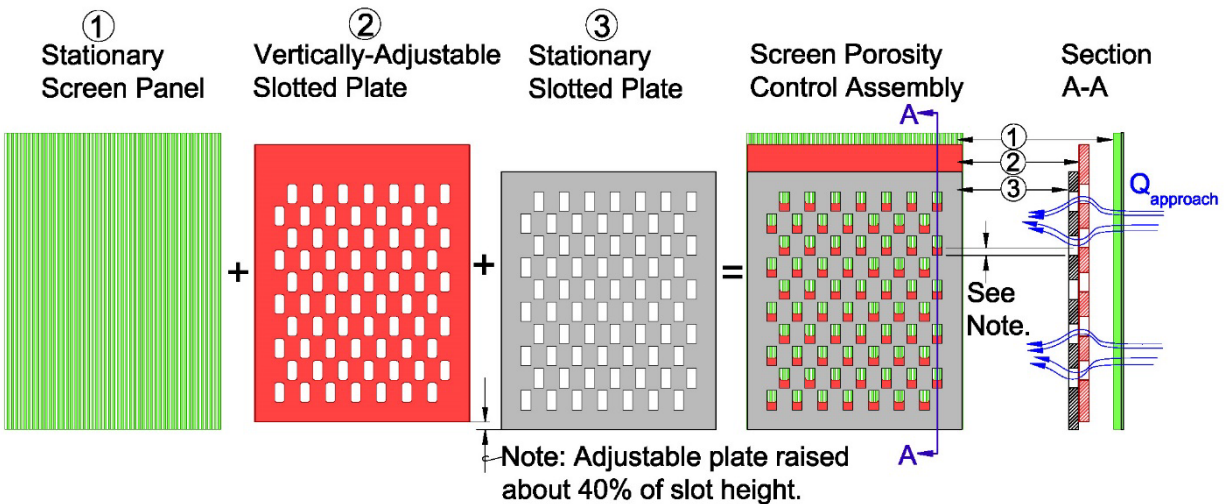

**Figure 8-6 Schematic diagram of sliding, overlapping porosity plates used to control porosity and achieve uniform flow conditions through fish screens**

### 8.5.5 Active Screen Cleaning Systems (Active Screens)

*All new fish screens should incorporate an automated cleaning system unless the project meets the requirements for passive screens listed in Section 8.5.6.*

### 8.5.5.1 Screen cleaning systems (in-canal or on-river screens)

*Screen cleaners should be capable of removing debris from the entire screen surface at least once every 5 minutes and should be operated as required to prevent debris accumulation. Cleaning systems should be designed to operate continuously or on an adjustable timer. On larger screens, the cleaning system should also be triggered whenever the head differential across the screen exceeds 0.3 foot over the clean screen condition. The cleaning system and operations protocol should be effective, reliable, and satisfactory to NMFS. Physical cleaning systems that use a travelling brush or wiper should provide a means for the brush to move away from the screen face at the downstream end of brush travel to allow for the release of accumulated debris.*

Fish screens operate most efficiently when they are clean and free of impinged material and attached growth such as algae or sponges (Bell 1991). Fish screen material with a porosity of about 50% will result in negligible head loss at the design approach velocity values identified in Section 8.5.1. Head loss across a screen due to impinged debris increases with the loss of screen open area at a geometric rate (BOR 2006). With increasing head loss, the force impinging debris (or fish) on the screen material also increases, making cleaning the screen more difficult. A screen experiencing 0.3 foot of head loss under an operating approach velocity of 0.4 ft/s may have less than 10% open area due to debris impingement. Under this condition, any weak-swimming fish coming in contact with the screen would experience injury or death due to the excessive forces acting on its body. Additionally, the water diversion would begin to experience significant reduction in diversion rate, and the facility could experience structural damage. Systems to monitor head differential across a screen should be designed to distinguish head loss due to debris impingement from loss caused by wave action or other transient disturbances.

Automated screen cleaning systems are generally categorized as physical, hydraulic, or pneumatic. Physical cleaning systems use a brush or other wiper device to physically remove impinged debris and attached growth and have a long history of successful deployments. NMFS recommends the use of a physical cleaning system for most screen applications; however, there are instances when a hydraulic or pneumatic cleaning system may be more practical.

Hydraulic cleaning systems use high-pressure water jets to remove debris from the screen face and rely on a current (or trash removal systems in the case of traveling belt screens) to remove debris from the vicinity of the screen facility. However, hydraulic cleaning systems do not remove attached growth as effectively as physical cleaning systems and may stimulate the growth of some types of algae.

Pneumatic cleaning systems use compressed air to lift debris from the screen face and rely on a current to remove debris from the vicinity of the screen facility. Pneumatic cleaning systems provide a cleaning force by displacing water primarily in the upwards direction; therefore, air burst cleaning systems in horizontal cylindrical screens may not remove debris impinged on the bottom of those screens. Pneumatic cleaning systems cannot completely remove attached growth and may stimulate the growth of some types of algae. If a screen material were to become occluded with attached growth, the compressed air can impart tremendous buoyant forces on the screen material and the facility overall. Screens employing a pneumatic cleaning system should consider the buoyancy force of trapped air when designing facility foundation and

structural components. An additional problem faced by pneumatic cleaning systems is that they are frequently undersized and cannot provide the required volume of air to clean the entire screen face. This is exacerbated by the tendency for the air bubbles to take the path of least resistance, which can often be the clean portions of the screen. Because pneumatic cleaning systems only lift debris from a screen, adequate sweeping flow should be present to move debris downstream away from the water intake.

#### **8.5.5.2 Screen cleaning systems for screens in quiescent and tidal areas**

*At locations that do not have sufficient sweeping velocity, fish screens should be equipped with an automated cleaning system that is capable of removing debris from the body of water, rather than one that may merely push debris to one side or the other.*

Effective cleaning systems rely on the sweeping flow, sometimes combined with the mechanical action of the cleaner, to carry the debris downstream and away from the screen face. Cleaning systems that merely push debris to the side of the screen face are inappropriate for low-velocity locations. This is because without a means to collect and remove debris, the debris lifted from the screen face is likely to become impinged again on the screen face. Additional measures are recommended in these situations to keep floating debris away from the face of a fish screen. Cleaning systems that push debris to the side of a screen are best suited for situations where sweeping flow is present that will carry any debris away from the screen.

#### **8.5.6 Passive Screens**

*A passive screen, meaning a screen without an automated cleaning system, may only be used when all of the following criteria are met:*

- *The combined rate of flow at the diversion site is less than 3 ft<sup>3</sup>/s.*
- *Sufficient ambient river velocity exists to carry debris away from the screen face.*
- *The site is not suitable for an active screen.*
- *Uniform approach velocity conditions exist at the screen face, as demonstrated by laboratory analysis or field verification.*
- *The debris load is low.*
- *A maintenance program exists that is approved by NMFS and implemented by the water user.*
- *The screen is frequently inspected, and debris accumulations are removed as site conditions dictate.*
- *For cylindrical screens, sufficient stream depth exists at the site to provide a water column of at least 1 screen radius around the screen surface.*
- *The screen is designed to be easily removed for maintenance and to protect it from flood events.*

#### **8.5.7 Screen Submergence and Clearance**

*Fish screens should be submerged sufficiently to maintain adequate wetted screen area to meet the approach velocity design criterion whenever the diversion is in operation; additional submergence is required in some circumstances.*

Effective screen area will be reduced if screen area becomes exposed due to a drop in the water surface. (Section 8.5.2) Under this condition the diversion rate should be adjusted and maintained such that the operating approach velocity does not exceed the design approach velocity criteria at any given time.

#### **8.5.7.1 Vertical flat plate screens**

*Fish screen facilities with flat, vertical screen panels, or panels inclined less than 20 degrees from vertical, should be designed to remain fully submerged over the entire range of expected water surface elevations. Facility designs may allow for vertical screen panels, or panels inclined less than 20 degrees from vertical, to become partially exposed when water surface elevation is lowered so long as the operating approach velocity does not exceed the design approach velocity.*

#### **8.5.7.2 Inclined flat plate screens**

*Fish screen facilities with flat plate screens installed at an incline of more than 20 degrees but less than 45 degrees from vertical should be designed to remain fully submerged over the entire range of expected water surface elevations. The top of the screen should be submerged a minimum of 1 foot at low stream design flow.*

The tops of inclined flat plate screens need to be sufficiently submerged at low stream design flow to prevent hydraulic conditions from forming at the interface between the screen and the water surface that could trap and impinge debris and fish.

#### **8.5.7.3 Rotary drum screens**

*For rotary drum screens, the design submergence should be between 65% and 85% of the drum diameter. In many cases, stop logs may need to be installed downstream of the drum screens to achieve the design submergence criteria. The stop logs should be located at least two drum diameters downstream from the back of the drum.*

Submergence levels greater than 85% of the drum diameter increase the possibility of entrainment over the top of the screen, fish impingement on the screen, and the subsequent entrainment of any fish impinged on the narrow screen area above the 85% submergence level due to the almost horizontal angle of impact of surface-oriented fish. Submergence levels that are less than 65% may reduce the self-cleaning capability of the screen due to the inability of material to temporarily adhere to the screen face and be carried over the top of the screen. Clay (1995) recommends that submergence be between 66% and 75% of the screen diameter. Examples of rotary drum screens are shown in Figures 8-7, 8-8, and 8-9.





**Figure 8-7 Large-sized rotary drum screen at the Sunnyside Canal located on the Yakima River near Yakima, Washington**

(Note: The person standing upstream of a drum and an intermediate bypass entrance. Water flow direction is from the foreground to the background of the photograph.)



**Figure 8-8 Medium-sized rotary drum screen at the Burlingame Diversion located on the Walla Walla River near Walla Walla, Washington**



**Figure 8-9 Rotary drum screens installed in a water diversion canal and operated (i.e., powered) by paddle wheels**

#### **8.5.7.4 Cylindrical screens**

*Cylindrical screens (other than rotary drum screens) should be submerged to a depth of at least 1 screen radius below the minimum water surface and have a minimum of 1 screen radius clearance between the screen surfaces and natural or constructed features.*

These clearances provide escape routes for fish to avoid the draw of water passing through the screen material.

#### **8.5.7.5 End-of-pipe screen submergence and clearance**

*All end-of-pipe screens should have adequate submergence below the water surface and adequate clearance from the streambed and any structure to provide an escape route for fish approaching the screen. For cylindrical-shaped screens, 1 screen radius or 6 inches, whichever is greater, is normally adequate submergence and clearance.*

Submergence and clearance requirements for screens with other shapes will be determined by NMFS on a case-by-case basis. An example of an end-of-pipe screen is shown in Figure 8-10.





**Figure 8-10 Typical end-of-pipe screen equipped with “wagon wheels” to elevate the screen off the stream bottom**

#### **8.5.7.6 End-of-pipe screen design**

*All end-of-pipe screens should meet the approach velocity criteria described in Section 8.5.1 and should be located in areas with sweeping velocities great enough to aid in moving fish and debris away from the intake. All end-of-pipe screens should be oriented to take maximum advantage of sweeping velocity in moving fish and debris away from the screen face.*

For the purposes of this document, an end-of-pipe screen is defined as a fish screen of any shape that may be attached to the end of a pipe or hose.

#### **8.5.7.7 Horizontal flat plate screens**

*Design criteria specific to horizontal screens are provided in Section 8.8.*

#### **8.5.7.8 Conical screens**

*Design criteria specific to cone screens are provided in Section 8.9.*

### **8.5.8 Screen Material**

*Screen materials should be corrosion-resistant and sufficiently durable so as to maintain a smooth, uniform surface over the course of long-term use. Perforated plate surfaces should be smooth to the touch, with the openings punched through in the same direction as the water flow.*

Screen materials commonly used include stainless steel, aluminum, plastic, and antifouling alloys containing copper and other metals.

#### **8.5.8.1 Opening size**

*The maximum screen opening allowed is based on the shape of the opening:*

- *Circular screen face openings should not exceed 3/32 inch in diameter (Neitzel et al. 1990a).*
- *Slotted screen face openings should not exceed 0.069 inch (1.75 millimeters [mm]) in the narrow direction (Mueller et al. 1995).*
- *Square screen face openings should not exceed 3/32 inch as measured on a diagonal (Neitzel et al. 1990b).*

#### **8.5.8.2 Open area**

*The percent open area (porosity) for any screen material should be at least 27%.*

#### **8.5.8.3 Gaps**

*Screens and associated civil works that are exposed to fish should be constructed such that there are no gaps greater than 0.069 inch (1.75 mm). For traveling belt screens or other screens with moving screen material, screen seals should be sufficient to prevent gaps larger than 0.069 inch (1.75 mm) from opening during screen operations.*

Clay (1995) notes that care is required in the construction, adjustment, and operation of rotary drum screens. The drum should be fitted carefully in the box to eliminate spaces around the edges that are larger than the openings in the screen mesh.

### **8.5.9 Civil Works and Structural Features**

#### **8.5.9.1 Smoothness**

*All concrete and steel surfaces, including edges and corners, in areas fish have access to should be smooth to the touch and free from burrs and sharp edges. These can injure fish or people that come in contact with the structure.*

#### **8.5.9.2 Pressure differential protection**

*Larger fish screen structures should be equipped with fail-safe systems that protect the structure from large pressure differentials across the screen face, should the screen become plugged. If a fail-safe system is tripped, the diversion operation should cease until the system can be reset and protection from entrainment into the diversion is restored.*

The fail-safe systems installed so that the structural integrity of the facility is never compromised may include governors that reduce the water diversion rate when the pressure differential exceeds a given value. Fused blow-out panels, slide gates, and pressure relief valves may also be acceptable solutions for preventing excessive pressure differentials that can result in screen facility failure.

### **8.5.9.3 Placement of screen surfaces**

*The face of all screen surfaces should be placed flush with any adjacent screen bay, pier noses, and walls to the greatest extent possible.*

This is needed to allow fish to have unimpeded movement parallel to the screen face and unobstructed access to bypass entrances and routes.

### **8.5.9.4 Structural features**

*Structural features should be provided to protect the integrity of fish screens from large debris and to protect the facility (Bell 1991).*

A trash rack, log boom, sediment sluice, and other measures may be required to protect the structural integrity of a fish screen, especially for on-river screens.

### **8.5.9.5 Civil works**

*The civil works should be designed in a manner that prevents undesirable hydraulic effects, such as eddies and stagnant flow zones, that may delay or injure fish or provide predator habitat or openings that allow predators to access the facility.*

### **8.5.9.6 Canal dewatering and fish salvage**

*For in-canal screens, the floor of the screen civil works should be designed to allow fish to be routed back to the river safely when the canal is dewatered. An acceptable fish salvage plan should be developed in consultation with NMFS and included in the O&M plan.*

Canal dewatering and fish salvage may be accomplished via the bypass system or by using a small gate and drain pipe, or similar provisions, to drain all flow and fish back to the river. The operations and maintenance plan should address the rate at which water can be drained back to the river to allow fish to move volitionally to the river to minimize stress. Trained personnel should be on site to rescue stranded fish. A rescue plan may need to consider collect lamprey larvae (ammocoetes) that may be living in sediments deposited in a diversion canal, and possibly even in sediments behind a fish screen.

## **8.6 Bypass Systems**

*Bypass systems are required for in-canal screens to provide a safe and efficient means of routing fish from the area in front of in-canal screens to the stream from which they were diverted.*

### **8.6.1 Bypass Design**

*Bypass systems should work in tandem with the fish screens to move all fish present (target and non-target species and all life stages) from the area in front of the screens and return them back to the stream or river (or to a holding pool, in the case of collection and transport facilities) with a minimum of injury and delay (Clay 1995).*

## 8.6.2 Bypass Entrance

*The bypass entrance should be located at the downstream terminus of the fish screens and should be designed to allow downstream migrants to easily locate and enter the bypass (Clay 1995). The screen and any guidewalls should naturally funnel downstream migrants and flow to the bypass entrance. For screens that are less than 6 feet in length and are constructed perpendicular to canal flow, the bypass entrance(s) may be located at either end (or both ends) of the screen.*

### 8.6.2.1 Flow control

*Each bypass entrance should be capable of controlling the flow rate through that entrance. If an orifice plate is used, the opening should have smooth, rounded-over edges and the opening should be large enough to safely pass the largest fish that may be entrained into the diversion canal. For steelhead kelts, the opening should be at least 8 inches in the smallest dimension.*

Typically, an overflow weir is used to regulate flow through the entrance. Orifice plates are discouraged from being used because they may hinder fish from moving into the bypass and they are more likely to clog with debris.

### 8.6.2.2 Minimum velocity

*The minimum bypass entrance flow velocity should be greater than 110% of the maximum canal velocity upstream from the bypass entrance. At no point may flow decelerate along the screen face or in the bypass channel. Bypass flow amounts should be of sufficient quantity to ensure these hydraulic conditions are achieved whenever downstream passage is required.*

### 8.6.2.3 Lighting

*Lighting conditions upstream of a bypass entrance should be ambient and extend downstream to the structure or device controlling bypass flow. In situations where transitions from light to dark conditions or vice versa cannot be avoided, they should be gradual or occur at a point in the bypass system where fish cannot escape the bypass and return to the canal (i.e., at a location where bypass flow velocity exceeds fish swimming ability).*

### 8.6.2.4 Dimensions

*For diversions greater than 3 ft<sup>3</sup>/s, the bypass entrance should extend from the floor of the canal to the water surface and be at least 18 inches wide (Ruggles and Ryan [1964] as cited in Clay [1995]). For diversions of 3 ft<sup>3</sup>/s or less, the bypass entrance should be a minimum of 12 inches wide. The bypass entrance should be sized to accommodate the entire range of bypass flow, utilizing the criteria listed in Section 8.6.*

#### **8.6.2.5 Weirs**

*For diversions greater than 25 ft<sup>3</sup>/s and where weirs are incorporated into the bypass entrance, the minimum water depth over the weir is 1 foot; however, a depth of 1.5 feet over a weir is preferred. Similarly, weir width should be a minimum of 1.5 feet; greater widths are preferred.*

Juvenile outmigrating salmonids appear to be less reluctant to go over a weir when water depth over the weir is greater than 1 foot (Manning et al. 2005). As a general rule and based on field observations, NMFS believes that water depth over a weir should be at least 1 foot, but if additional flow is available, a depth of 1.5 feet or even 2 feet is preferred. Manning et al. (2005) reported significantly faster travel times for steelhead moving through a dam forebay when the crest of an inflatable spillway was deformed and water depth and velocity over the spillway were increased. Water depth increased from 0.13 foot to 2.4 or 3 feet, and water velocity increased from 0.2 ft/s to 3.9 or 4.6 ft/s during test replicates. Also, wider passageways are preferred; the recommended minimum width is 1.5 feet.

#### **8.6.2.6 Intermediate bypass entrances**

*The fish screen design should include intermediate bypass entrances if the design approach velocity is greater than 0.33 ft/s and the sweeping velocity may not convey fish to a terminal bypass entrance within 60 seconds, assuming that fish are transported along the length of the screen face at a rate equal to the sweeping velocity.*

Clay (1995) notes that if the screen is extremely long, it may be advisable to place bypass entrances at intervals across the face.

#### **8.6.2.7 Training walls**

*All intermediate bypass entrances should have a training wall to guide fish into the bypass system.*

#### **8.6.2.8 Flow acceleration**

*All bypass entrances should be designed to gradually accelerate flow into the bypass entrance and between the entrance and the flow control device at a rate not to exceed 0.2 ft/s per linear foot.*

Juvenile salmonids have been observed to resist moving with water flow that accelerates too quickly (Haro et al. 1998). Brett and Alderdice (1953), as referenced in Clay (1995), recommend a uniform acceleration rate of no more than 0.1 ft/s per linear foot.

#### **8.6.2.9 Secondary dewatering screens**

*Secondary dewatering screens should meet all design criteria (e.g., approach velocity, sweeping velocity, cleaning, and screening material) of the primary screens.*

Secondary dewatering screens may be used within the bypass system to reduce bypass flow.

### **8.6.3 Bypass Conduit and System Design**

#### **8.6.3.1 Bypass conduit**

*Depending on the site-specific conditions, the bypass conduit can be either U-shaped flume or round pipe.*

#### **8.6.3.2 Surface smoothness**

*The interior surfaces and joints of bypass flumes or pipes should be smooth to the touch to provide conditions that minimize turbulence, the risk of catching debris, and the potential for fish injury.*

Pipe joints may be subject to inspection and approval by NMFS prior to completion of the bypass. Every effort should be made to minimize the length of the bypass pipe while meeting the hydraulic criteria listed in Sections 8.6.3.4 through 8.6.3.6.

#### **8.6.3.3 Bypass pipe diameter**

*The minimum bypass pipe diameter is 10 inches.*

The bypass flume or pipe diameter is a function of the bypass flow and slope, and the diameter incorporated into the bypass pipe design should achieve the velocity and depth criteria identified in Sections 8.6.3.5 and 8.6.3.6. Bypass flume or pipe hydraulic characteristics should be calculated to determine a suitable pipe diameter.

#### **8.6.3.4 Bypass flow rate**

*The minimum design bypass flow is 5% of the total diverted flow rate unless otherwise approved by NMFS.*

While the minimum bypass flow is 5% of the total diverted, larger bypass flow proportions will aid in cleaning the fish screen and will guide fish toward the bypass system more quickly.

#### **8.6.3.5 Bypass velocity**

*Water velocity in the bypass conduit should be between 6 and 12 ft/s for the entire operational range of bypass flow, and should always be greater than 2 ft/s. If higher velocities are approved by NMFS, special attention to pipe and joint smoothness should be demonstrated by the design.*

Bypass systems with velocities that are less than 2 ft/s can accumulate sediment deposits within the bypass system.



### 8.6.3.6 Water depth

*The design minimum depth of free surface flow in a bypass pipe should be at least 40% of the bypass pipe diameter unless otherwise approved by NMFS.*

### 8.6.3.7 Closure valves

*Closure valves cannot be used within the bypass system unless specifically accepted by NMFS.*

### 8.6.3.8 Pumps

*Fish should transition through bypass system components via gravity flow and never be pumped. Use of a pump would only be acceptable if NMFS required the installation of a bypass where insufficient head was available to support gravity flow.*

### 8.6.3.9 Downwells and flow transitions

*Downwells should be sized based on an EDF between 8 to 10 ft-lb/ft<sup>3</sup>/s. Fish should never free-fall within a bypass system pipe or enclosed conduit. Downwells should be designed to produce a free water surface when turbulence, geometry, and alignment aspects of the design are considered.*

Equation 8-1 should be used to calculate downwell volume.

$$V = \frac{(\gamma)(Q_{bypass})(H)}{EDF} \quad (8-1)$$

where:

- $V$  = pool volume (ft<sup>3</sup>)
- $\gamma$  = unit weight of water (62.4 lb/ft<sup>3</sup>)
- $Q_{bypass}$  = bypass flow, in ft<sup>3</sup>/s
- $H$  = height of drop between water surfaces, in feet
- $EDF$  = energy dissipation factor, from 8 to 10 ft-lb/ft<sup>3</sup>/s

### 8.6.3.10 Pressurized flow

*Flow in all types of fish conveyance structures should be open channel (i.e., not pressurized). Bypass systems should be vented or open to the atmosphere. If a pressurized bypass conveyance is required by site constraints, pressures in the bypass pipe should remain equal to or above atmospheric pressures. Transitions from pressurized to non-pressurized conditions within a bypass pipe, and vice versa, should be avoided.*

### 8.6.3.11 Bends

*The ratio of bypass pipe center-line radius of curvature (R) to pipe diameter (D), or R/D, should be greater than or equal to 5. If mitered pipe fittings are used to change conveyance direction, the maximum miter angle allowed is 15 degrees (11.25 degrees is preferred). If multiple miter joints are used to change the direction of the conveyance more than 15 degrees,*

*each miter joint should be separated by length(s) of pipe that are sufficiently long to achieve the required ratio of R/D for the bend assembly as a whole.*

In situations that involve super-critical flow velocities, R/D ratios greater than 5 may be required. Bends should be minimized in the layout of bypass systems due to their potential to facilitate debris clogging and produce turbulence.

#### **8.6.3.12 Debris management**

*Bypass pipes or open channels should be designed to minimize debris clogging, sediment deposition, and facilitate their inspection and cleaning as necessary.*

#### **8.6.3.13 Access for maintenance**

*Access for maintenance inspections and debris removal should be provided at locations in the bypass system where debris accumulations may occur. Bypass systems greater than 150 feet in length should include access ports at appropriate spacing to allow for the detection and removal of debris.*

Alternate means of providing for bypass pipe inspection and debris removal may be considered by NMFS.

#### **8.6.3.14 Natural channels and fishways**

*Natural channels and fishways may be used as a bypass transit channel under limited circumstances and only upon approval by NMFS.*

Use of natural channels and fishways as juvenile fish bypasses expose fish to increased delay and predation (compared to a typical bypass system). Use of a natural channel will require that adequate water depth and velocity, flow volume, protection from predation, and good water quality conditions can be provided. The potential for increased predation is typically extremely high for natural channels due to the high concentration of fish in a small amount of flow in the bypass system and area. Additionally, sufficient flow would be required to mitigate for any seepage occurring within the bypass system while maintaining adequate water depth and velocity. If a natural channel is to be used, special consideration needs to be given to where the bypass channel connects to the river.

#### **8.6.3.15 Sampling facilities**

*Sampling facilities installed in the bypass conduit should not impair the operation of the facility during non-sampling periods in any manner.*

Refer to Appendix F for additional information on the design of juvenile fish sampling facilities.

#### **8.6.3.16 Hydraulic jumps**

*There should be no hydraulic jump(s) within a bypass system.*

## 8.6.4 Bypass Outfalls

### 8.6.4.1 Location

*Bypass outfall locations should meet the following conditions:*

- *Bypass outfalls should be located to minimize predation by selecting an outfall location that is free of eddies and reverse flow and does not place bypassed fish into an area of known predator habitat (Bell 1991).*
- *The point of impact for bypass outfalls should be located where ambient river velocities are greater than 4 ft/s when in operation (Shively et al. 1996).*
- *Bypass outfall locations should provide good egress conditions for juvenile fish exiting the bypass and re-entering the stream channel (Bell 1991).*
- *The bypass flow should not impact the river bottom or other physical features at any stage of river flow. Bypass outfalls should be located where the receiving water is of sufficient depth to ensure that fish injuries are avoided at all river and bypass flows.*
- *The bypass outfall should not release fish into areas where conditions downstream from the bypass discharge point will pose a risk of injury, predation, or stranding (Bell 1991). For example, bypass outfalls should avoid discharging fish into areas from which they can enter reaches where flows run subsurface. Also, bypass outfalls should not discharge in the vicinity of any unscreened water diversion or near eddies that may be habitat for predator fish.*

### 8.6.4.2 Impact velocity

*Maximum bypass outfall impact velocity (i.e., the velocity of the bypass flow as it enters the receiving water) should be less than 25 ft/s, including both the vertical and horizontal velocity components (Bell 1991).*

Impact velocity may be greater for very large bypass flows that discharge a confined jet that plunges deep into the receiving waters and results in fish deceleration occurring over a longer distance compared to a broader jet not plunging far into the receiving water. For example, Johnson et al. (2003) reported no injuries to juvenile Chinook salmon that were returned to the Columbia River in bypass flow greater than 1,000 ft<sup>3</sup>/s and when impact velocities ranged up to 50 ft/s.

### 8.6.4.3 Predation prevention

*Predator control systems may be required in areas with a high potential for avian predation.*

Predation suppression systems include bird wires (thin wires) strung over the bypass outfall area to prevent predatory birds from flying near the outfall or diving at fish exiting the outfall and high-pressure water spray nozzles over the outfall area to deter birds.

### 8.6.4.4 Adult fish attraction to bypass discharge

*Bypass outfall discharge into the receiving water should be designed to avoid attracting adult fish to the discharge. If the potential exists that adult salmonids may be attracted to and*

*jump at the bypass outfall discharge, the design of the bypass outfall should include a provision for adult fish to land safely in a zone or location after jumping.*

## **8.7 Water Drafting**

Water drafting is the practice of pumping water for short durations from streams or impoundments at low pumping rates to fill water trucks or tanks, often for dust suppression or wildfire management. Water drafting may also be used to dewater a construction site or temporarily divert water around a construction site. When dewatering a construction site an approved dewatering plan should be followed to rescue and relocate stranded fish.

The specifications below are primarily for the protection of juvenile anadromous salmonids in waters where they are known to exist. However, they may also be applied to protect a host of other aquatic organisms.

### **8.7.1 Water Drafting Operating Guidelines**

*When engaged in water drafting operations, the following restrictions apply:*

- *Operations are restricted to 1 hour after sunrise to 1 hour before sunset.*
- *The pumping rate should not exceed the lesser of 350 gpm or 10% of the streamflow. The operator should measure streamflow prior to initiating pumping to ensure the pumping rate will not exceed 10% of streamflow.*
- *Pumping should be restricted to locations where the water is deep and flowing; pumping from isolated pools should be avoided.*
- *Pumping should not result in a drawdown of the water surface elevation by more than 10% in the area where pumping is taking place nor in any riffles downstream.*
- *Pumping should be terminated when the water truck or tank is full.*
- *An operator should be present during pumping operations and observe stream conditions during pumping to ensure the above restrictions are being met.*
- *A fish screen should be used when pumping. Fish screens should meet guidelines for end-of-pipe screens of this document (Section 8.5.7.5). The operator should be capable of cleaning debris from the fish screen when needed and possess the equipment necessary to do so.*
- *Water drafting truck parked on streambeds, floodplains, or within a riparian corridor should use drip pans or other devices such as absorbent blankets, sheet barriers or other materials as needed to prevent soil and water contamination from motor oil or hydraulic fluid leaks*

### **8.7.2 Fish Screens for Water Drafting**

Design and operation criteria and guidelines for use of fish screens required during pumping operations for water drafting are described in Section 8.7.2.1 through 8.7.2.6.

#### **8.7.2.1 Design**

*Fish screens for water drafting may be off-the-shelf designs or custom fabricated. The fish screen should be sturdy enough to not compromise the integrity of the screen during pumping when the screen becomes clogged with debris.*

The screens may be cylindrical or rectangular in shape as long as the other screen criteria are met.

#### **8.7.2.2 Cleaning**

*Fish screens for water drafting do not need to have an automated cleaning system; however, an operator should regularly clean the screen during the pumping operation to maintain the minimum amount of screen area that is required to not be occluded with debris.*

#### **8.7.2.3 Approach velocity**

*The design approach velocity should not exceed 0.33 ft/s.*

Based on a pumping rate of 350 gpm, the screen for this flow rate should have at least 2.4 ft<sup>2</sup> of surface area.

#### **8.7.2.4 Uniform flow**

*Screens should be designed to draw water relatively uniformly over the entire screen area.*

Screens may require internal baffles to achieve this criterion.

#### **8.7.2.5 Screen porosity and openings**

*The screen material should have a porosity of at least 27% and have openings consistent with criteria provided in Section 8.5.8.1. The screen surface should be smooth to the touch.*

The size of screen openings depends on the shape of the openings.

#### **8.7.2.6 Screen support and submergence**

*Fish screens should be supported off the stream bottom by at least 6 inches and be submerged by at least 6 inches (Figure 8-10).*

## **8.8 Special Case: Horizontal Screens**

Horizontal flat plate screens operate fundamentally differently than conventional cylindrical and vertically oriented screens. This fundamental difference relates directly to fish safety. When inadequate flow depth exists with vertically oriented screens, the bypass will usually remain operational, and there is only a slight increase in the potential for fish to become impinged on the surface of the screen. In contrast, when the water level on horizontal screens drops and most or all diverted flow goes through the screens, the bypass flow is greatly reduced or ceases completely and there is a high likelihood that fish will become impinged and expire on the screen surface.

### **8.8.1 NMFS Engineer Involvement**

*Since site-specific design considerations are required, NMFS should be consulted throughout the development of a horizontal screen design.*

NMFS considers horizontal screens to be biologically equivalent to conventional screens if the design and operation of a horizontal screen meets the criteria and conditions listed in Section 8.8.

### **8.8.2 Design Process**

*The horizontal screen design process should include an analysis to verify that sufficient hydrologic and hydraulic conditions exist within the stream so as not to exacerbate a passage impediment in the stream channel or in the off-stream conveyance (including the screen facility and bypass system). This analysis should conclude that all of the following criteria can be achieved for the entire fish passage season, as defined in Chapter 2. If the criteria listed here in Section 8.8 cannot be maintained per this design analysis, a horizontal screen design should not be used at the site. If this analysis concludes that the removal of the bypass flow required for a horizontal screen from the stream channel results in inadequate passage conditions or unacceptable loss of riparian habitat, other screen design styles should be considered for the site and installed at the site if the other screen styles will reduce the adverse effects to passage or riparian habitat.*

### **8.8.3 General Criteria**

*The screen and bypass criteria specified in Chapter 8 apply to horizontal screens. The exceptions to these general criteria are noted in Section 8.8.4.*

### **8.8.4 Specific Criteria**

As described in Section 8.8, horizontal flat plate screens are fundamentally different than conventional cylindrical and vertically oriented screens. Specific criteria and guidelines that apply only to horizontal screens are described in Sections 8.8.4.1 through 8.8.4.13.

#### **8.8.4.1 Site limitation**

*Horizontal screens should be installed in an off-river canal.*

Due to the need for very precise hydraulic controls, horizontal screens are not suitable for in-river or in-stream installations.

#### **8.8.4.2 Flow regulation**

*For a horizontal screen facility to function properly, the site should provide a headgate facility that maintains a water diversion rate that is sufficient and consistent enough to allow the fish screen and bypass system to meet the criteria listed in this section (Section 8.8.4).*

#### **8.8.4.3 Channel alignment**

*Horizontal screens should be installed such that the approaching conveyance channel is parallel to, and in line with, the screen channel (i.e., there is no skew), and uniform flow conditions exist across the upstream edge of the screen. A straight channel should exist for at least 20 feet upstream of the leading edge of the screen, or for a distance of up to two screen channel lengths if warranted by approach flow conditions in the conveyance channel. Horizontal screens should be installed such that a smooth hydraulic transition occurs from the approach channel to the screen channel and there are no areas of abrupt flow expansion, contraction, or separation.*

Flow conditions that require a longer approach channel include turbulent flow, supercritical hydraulic conditions, or uneven hydraulic conditions in a channel cross section.

#### **8.8.4.4 Bypass flow depth**

*The bypass flow should pass over the downstream end of the screen at a depth of at least 1 foot.*

#### **8.8.4.5 Bypass flow amount**

*Bypass flow amounts should be sufficient to continuously provide the hydraulic conditions specified in this section and those specified in Section 8.6. In general, for diversion rates of less than 100 ft<sup>3</sup>/s, approximately 15% of the total diverted flow should be used as bypass flow. For diversion rates greater than 100 ft<sup>3</sup>/s, approximately 10% of the total diverted flow should be used for bypass flow. Small horizontal screens may require up to 50% of the total diverted flow be dedicated for bypass flow. The amount of bypass flow should be approved by NMFS.*

Bypass flow is used for transporting fish and debris across the plane of the screen and through the bypass conveyance back to the stream.

#### **8.8.4.6 Diversion shut-off**

*If hydrologic analysis demonstrates that the diverted flow rate could drop below the flow rate required to satisfy the diversion and supply the bypass with its full design flow rate, the horizontal screen design should include a means to automatically shut off the diversion flow or a means to route all diverted flow back to the originating stream.*

#### **8.8.4.7 Sediment removal**

*The horizontal screen design should include a means to simply and directly remove sediment that accumulates under the screen without compromising the integrity of the screen while water is being diverted.*

#### **8.8.4.8 Screen approach velocity**

*Screen approach velocity should be less than 0.25 ft/s and uniform over the entire screen surface area. If the horizontal screen is equipped with an automated mechanical screen cleaning system, screen approach velocity should be less than 0.4 ft/s and uniform over the entire screen surface area.*

The best available science regarding horizontal screens is evolving. Therefore, NMFS may require a lower approach velocity or may specify a minimum ratio of sweeping velocity to approach velocity. Recent prototype development has demonstrated that better self-cleaning of a horizontal screen is achieved when the ratio of sweeping velocity and approach velocity exceeds 20:1, and approach velocities are less than 0.1 ft/s.

#### **8.8.4.9 Screen sweeping velocity**

*Sweeping velocity should be maintained or gradually increase for the entire length of screen. Sweeping velocity should never be less than 2.5 ft/s or an alternate minimum velocity approved by NMFS that is based on an assessment of sediment load in the water diversion system.*

Higher sweeping velocities may be required to achieve reliable debris removal and to keep sediment mobilized.

#### **8.8.4.10 Post-construction inspection and testing**

*Upon completion of screen construction and watering up of the system, velocity testing should be performed to ensure that approach velocity is uniform over the entire screen area. For the purpose of this test, uniform is defined as all test velocities falling between 90% and 110% of the nominal screen approach velocity. Sweeping velocity should also be verified to be in a uniformly downstream direction to ensure that fish and debris are bypassed rapidly.*

#### **8.8.4.11 Monitoring and maintenance**

*Daily inspection and maintenance (if required) should occur on the screen and bypass system to maintain operations consistent with these criteria.*

#### **8.8.4.12 Post-construction monitoring**

*Post-construction physical and operational monitoring of all components of new horizontal screen facilities should occur for at least the first year of operation and cover all periods of operation.*

#### **8.8.4.13 Inspection log**

*An inspection log should be kept for each horizontal screen. A copy of the inspection log should be provided annually to the NMFS design reviewer upon request, who will review the inspection log and may make recommendations for the next year of operation. The inspection log should include:*



- *Inspection dates, times, and the observer's name*
- *Water depth at downstream end of the screen (i.e., the entrance to the bypass)*
- *Debris present on the screen, including any sediment retained in the screen openings*
- *Fish observed on or passing over the screen surface*
- *Operational adjustments and maintenance performed on the facility*

## 8.9 Special Case: Conical Screens

Conical (or cone) screens were developed for small water diversions in shallow tidal areas. They have been installed on pumped and gravity diversions since 1996. The conical shape provides a large amount of screen area in a small footprint (Figure 8-11). The screen units sit on a constructed steel or concrete platform connected to a diversion pipe. They have rotating brush cleaning systems that are driven by hydraulic or electric motors, some of which run off batteries charged by solar panels. Turbine-driven units, where the cleaning system is driven by a propeller installed in the conveyance pipe and mechanically connected to the cleaning system through a large gear reducer, have been used successfully in a few cases. For turbine-driven units, screen cleaning does not occur unless water is being diverted. A turbine-driven cleaning system may not be appropriate for seasonal use unless the units are removed seasonally.



**Figure 8-11 Conical screen**

Conical screens were designed for use on inverted siphons in tidal areas where the screen units would be partially exposed at lower tides. Because they were used only on siphons, as the source water stage decreased on an ebb tide and screen area became exposed, the rate of diversion decreased proportionally so the operational approach velocity never exceeded the design approach velocity. As a side benefit, the daily exposure to air and sunlight helped keep the screen surface free of algal growth.

### 8.9.1 Locations

*Conical screens should be sited in locations where fish have a clear escape route past a screen. They should not be installed in enclosed vaults or in close proximity to a structure that prevents fish from freely moving away from the screen.*

#### 8.9.1.1 Maximum ambient velocity

*Conical screens are acceptable for use in lakes, reservoirs, backwater channels, and tidal areas where the ambient velocity does not exceed 1 ft/s. They may be used where the current is greater than 1 ft/s if other (i.e., superior) screening alternatives are not available, an appropriate flow distribution baffle system is used, and the design is acceptable to NMFS.*

### 8.9.2 Approach Velocity

*The maximum design approach velocity for conical screens is 0.33 ft/s.*

The minimum effective screen area required for an installation may be determined by dividing the maximum diversion rate in ft<sup>3</sup>/s by 0.33 ft/s.

### 8.9.3 Flow Uniformity

Conical screens have been equipped with two types of baffle systems to distribute flow over all screen area. Early screens used an inverted cone design that divided the interior space into upper and lower areas. That design performed well in quiescent water with a narrow plenum, but field testing in a live stream showed that the inverted cone baffle did not balance flows well when flow was moving past the screen. In fact, the approach velocity on the leading edge of the screen unit could exceed the design value even when not diverting water because stream flow could enter the upstream side and exit the downstream side. To solve this problem, a new baffle design was developed.

The BOR's Technical Service Center near Denver, Colorado, developed a relatively complex baffle system with vertical dividers and a central flow balancing cylinder to distribute intake flow more evenly into four hydraulically-isolated quadrants (Hanna 2011). The vertical dividers prevented stream flow from passing completely through the screen unit. The manufacturer routinely includes a simplified internal baffle based on the USBR design in all of their conical screens.

BOR also tested an external baffle system to control how water approaches and passes into a conical screen (Hanna 2013). The external baffle concept created more uniform flow into the screen but debris could accumulate on the baffles in a riverine setting; therefore, NMFS recommends the use of an internal baffle system to allow stream flow to move debris and fish away from the diversion intake.

### 8.9.4 Effective Screen Area

*All screen area submerged greater than 6 inches may be considered as effective screen area (Figure 8-12). If conical screens become exposed to air, the rate of diversion should be reduced to meet the design approach velocity criterion (Section 8.9.2) due to the reduced effective screen area.*

When conical screens become exposed to air in tidal or backwater environments, the top 6 inches of screen material below the water surface may become occluded by debris.

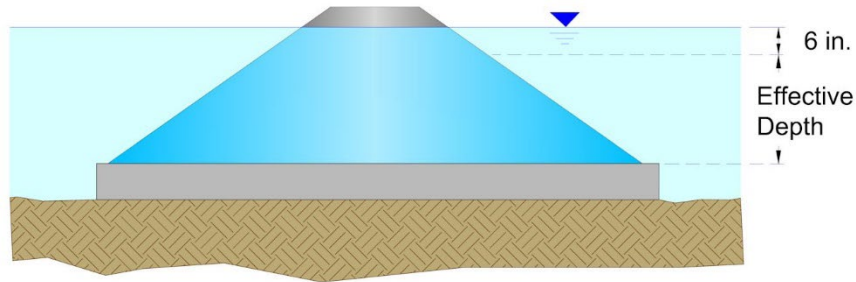

**Figure 8-12 Elevation view of a conical fish screen showing the effective depth**

### **8.9.5 Submergence**

*Conical screens may be operated while partially exposed above water but should be designed such that the screen is sufficiently submerged to maintain adequate effective screen area for the rate of diversion at any given moment.*

The definition of effective screen area is provided in Section 8.5.2.

## **8.10 Project Inspections and Evaluations**

### **8.10.1 General**

*Inspections and evaluations should be performed at each appropriate phase of a project. This includes during construction, when the project is substantially complete but not yet operating, and after construction.*

Inspections of project details and evaluations of project systems are necessary to ensure that a fish screen project functions as intended.

### **8.10.2 Quality Assurance and Quality Control**

*An on-site project engineer or inspector should be assigned to every project. The inspector should provide notice to NMFS of key milestones in the construction process and access to the site for inspections.*

The inspector is responsible for ensuring construction specifications and tolerances are met and for testing all project systems. NMFS should be allowed to witness testing of project systems.

### **8.10.3 Inspection**

#### **8.10.3.1 During construction**

*During the course of construction, activities may preclude various facets of screen and bypass construction from being inspected. In instances where these facets of construction may pose a risk of injury or mortality to fish later on during normal operations, the on-site engineer or inspector should inspect these items prior to construction continuing. In some instances, NMFS may require that a NMFS inspector be given the opportunity to inspect these items prior to construction continuing. If this is the case, NMFS will provide the project proponent with a list of screen and bypass elements that will require NMFS inspection during the course of construction. These may include (but are not limited to) the following:*

- *Bypass pipe joints, either welded or mechanical*
- *Bypass downwells*
- *Bypass outfalls, if protected during construction by a cofferdam*
- *Any components that convey water that may contain fish*

#### **8.10.3.2 Facilities near completion**

*Nearly completed fish screen and bypass facilities should be made available to NMFS staff for inspection prior to watering up to verify that the screen is operable in a manner consistent with the design criteria. NMFS staff may inspect construction quality, pipe joints, fit, and finish of components exposed to fish.*

#### **8.10.3.3 Evaluations**

At some sites, screen and bypass facilities may need to be evaluated for biological effectiveness and to verify that hydraulic design objectives are achieved and debris removal systems are effective. At the discretion of NMFS, this may entail a complete biological evaluation, especially if waivers to screen and bypass criteria are granted, or merely a visual inspection of the screen in operation if the screen is relatively simple and designed and constructed to the standard criteria listed throughout the chapters of this document.

#### **8.10.3.4 Mechanical and electrical systems evaluations**

*Testing of mechanical and electrical systems should be performed before initiating operations.*

This should include testing of any alarm systems, including audible alarms, pagers, and other warning systems; data recording equipment, emergency shut-off systems, cleaning systems, actuators, and solenoids; backup systems; and other mechanical and electrical systems. These evaluations should be included in a list of final items to be completed by the contractor and carried out prior to contractor demobilization and should be written into the construction contract.

#### **8.10.3.5 Automatic cleaning systems evaluations**

*Cleaning systems and their components should be tested in the dry, when possible, and again when screen facilities are operable, but prior to initiating normal operations.*

Using O&M documentation of the cleaning systems provided by the designer or fabricator, all cleaning systems should be tested in automatic and manual operating modes. These evaluations should be included in a list of final items to be completed by the contractor and carried out prior to contractor demobilization and should be written into the construction contract.

#### **8.10.3.6 Biological evaluations**

*Depending on the size of a project, any variances from established criteria, and the complexity and uniqueness of the project design, NMFS may require that biological evaluations be conducted on a fish screen facility. The biological evaluations may involve monitoring fish that naturally inhabit the site or releasing test fish obtained from another source such as a hatchery. If biological evaluations are required, the applicant must submit a biological evaluation study plan to NMFS for review and approval prior to completing a substantial portion of the project. Biological evaluations must be performed by qualified personnel using established methods.*

The biological evaluations could include monitoring to assess the number of fish being injured or delayed, entrained behind the fish screen, impinged on the fish screen and evidence of fish predation associated with the water intake structure. The biological evaluation study plans should describe the source of fish, test equipment, and methods that will be used; the statistical analysis that will be conducted and associated precision of any tests; and the proposed frequency, timing, and duration of any monitoring and testing.

#### **8.10.3.7 Juvenile fish bypass systems**

*Hydraulic testing of juvenile fish bypass systems is required to create rating curves for gate openings needed to achieve prescribed flow rates, and to ensure that the bypass system hydraulics conform to hydraulic design criteria.*

*Biological testing of juvenile bypass systems may be required to ensure that juvenile fish are being returned safely to the main river channel. If biological evaluations are required, the applicant must submit a biological evaluation study plan to NMFS for review and approval prior to completing a substantial portion of the project. Biological evaluations should be performed by qualified personnel using established methods.*

The study plan should consider the complexity of the bypass system and the size and number of juvenile fish likely to be present during water diversion operations.

### 8.10.3.8 Fish screen hydraulic evaluations

The hydraulic evaluations described in this section are required for fish screen facilities. Appendix E (Performing Hydraulic Evaluations) provides information on how to conduct hydraulic evaluations.

*Hydraulic evaluations are required on all screens equipped with adjustable flow tuning baffles designed to distribute flow evenly over all wetted screen areas, and where confirmation of hydraulic conditions at a fish screen is necessary. The applicant should submit a hydraulic evaluation study plan to NMFS for review and approval prior to completing a substantial portion of the project. The final hydraulic evaluation should be conducted under the high design (diversion) flow unless otherwise agreed to by NMFS.*

Hydraulic evaluations involve taking water velocity measurements at locations that are oriented both perpendicular (i.e., the approach velocity) and parallel (i.e., the sweeping velocity) to the screen face. Hydraulic evaluations are used on screen facilities with flow-balancing baffles to adjust the baffles to achieve uniform approach velocities across all wetted screen surfaces. Baffle systems should be adjusted in this manner prior to initiating normal water diversion operations. The hydraulic evaluation plan should include the proposed equipment, methods, and time schedule that will be used when conducting the hydraulic evaluations.

*In the event that hydraulic conditions are found by NMFS to be unacceptable and the existing baffle system is incapable of adjusting flows to meet the hydraulic criteria, physical modifications to the facility may be required along with follow-up hydraulic evaluations of the modified hydraulic conditions.*

*Hydraulic evaluations should be carried out as soon as practical to ensure the facility is operating as near to design criteria as practical using the guidelines described in Appendix E. If the facility cannot be operated at an optimal diversion rate for the hydraulic evaluation within the first year of operation, the facility owner should seek to extend the deadline for carrying out the hydraulic evaluation from NMFS.*

*Hydraulic evaluations should be performed by qualified personnel using established methods.*

*A final hydraulic evaluation report should be provided to NMFS that includes the following:*

- *A description of site and environmental conditions at the time of testing*
- *A list of technicians performing tests*
- *The materials and methods employed in the test, including locations of all velocity measurements in the final iteration of baffle adjustments, including justification of the number of points at which velocity measurements were taken*
- *A description of the final baffle settings*
- *The approach and sweep velocity data for all measured points in the final iteration of baffle adjustments presented in a table format*
- *The approach and sweeping velocity values for all measured points in the final iteration of baffle adjustments presented in a graphical format*

- *An objective evaluation of hydraulics at the site and anticipated screen performance*

## **8.11 Operations and Maintenance Plans**

### **8.11.1 General**

*All fish screen projects should have an approved O&M plan. The plan should include procedures deemed acceptable by NMFS for operating the screen facility under a variety of environmental conditions, the full range of water diversion operations, and the procedures for periodic inspections and maintenance required to achieve fish screening effectiveness over the design life of the facility.*

The purpose of an O&M plan is to ensure that the facility performs as designed and is providing effective fish screening over the life of the project. The O&M plan is the manual that describes exactly how the fish screen facility will be operated and maintained as well as procedures and personnel to contact in the event of emergencies. The following guidelines provide a template that can be used to prepare an O&M plan.

### **8.11.2 Operations**

*The O&M plan should include procedures that will ensure the fish screen meets all previously agreed to criteria. In addition to normal operation conditions, the plan should include information, procedures (including fish salvage plans), and personnel contact information in case of emergencies.*

The O&M plan should include the seasonal maximum diversion rates agreed to in the design process, other criteria identified in the project description, project mitigation measures, and any applicable permit conditions or ESA Biological Opinion requirements. Additionally, the plan should address specific criteria on pump use at pumped diversions and gate use at gravity diversions that are required to achieve uniform approach velocities across screen surfaces.

#### **8.11.2.1 Posting**

*A list of operating procedures that is easy to follow should be posted in a highly visible location at the water diversion site.*

The list should include specific operating procedures needed to achieve uniform approach velocities across the screen face at various diversion rates. Emergency power cut-off switches, pressure relief valves, instructions for operating any auxiliary equipment, and emergency shutdown procedures should also be placed in locations that are easily found.

### **8.11.3 Maintenance**

*The diversion owner should incorporate maintenance procedures recommended by the designers, contractors, and suppliers into the O&M plan.*

The maintenance section of the O&M plan should specify the frequency and interval for performing each maintenance procedure. The project owner is responsible for obtaining

documentation (including specifications and maintenance requirements) from suppliers of off-the-shelf and custom systems and equipment and ensuring that all necessary maintenance equipment, tools, and component parts are readily available and on-hand for the maintenance. The O&M manual should identify activities that need to be carried out on a periodic basis (e.g., daily, weekly, monthly, quarterly, annually, or another periodic schedule).

#### **8.11.4 Maintenance Records**

*The facility owner should maintain a log of O&M activities, which should be made available upon request of appropriate federal and state agencies. The logbook should include the following:*

- *One copy of the operating procedures list discussed above (Section 8.11.2)*
- *One copy of the periodic maintenance schedule discussed above (Section 8.11.3)*
- *Records of regularly scheduled and unscheduled maintenance procedures performed*

#### **8.11.5 Periodic Visual Inspections**

*The project owner, or their agent, should perform visual inspections of the screens on an annual basis or more frequently if required to ensure design criteria are being met. Inspectors should examine cleaning system performance, structural integrity of the screen area, fish-exclusion integrity of seals and transition areas, and other factors affecting screen facility performance. Inspectors should determine if the current maintenance procedures are sufficient to ensure that screen performance will continue to meet the facility's design criteria into the future.*

Guidelines for conducting periodic inspections are as follows:

- Auditing maintenance records:
  - Review the O&M logbook to identify any recurring problems.
  - Compare logged records with the O&M plan to ensure the plan is under compliance and note any areas that need troubleshooting.
- Inspecting underwater components:
  - Check for gaps at joints and seams that could compromise screen efficiency.
  - Note any accumulation of debris.
  - Inspect screen material for damage and material integrity.
  - Check screens and structural members for corrosion, wear, or other deterioration.
  - Check sacrificial anodes and replace if necessary.
  - Check screen hold-down plates and other protrusions from the screen face for damage and debris accumulation.
- Witness cleaning system operations:
  - Intentionally foul the fish screen with locally available materials if possible and view the efficiency of the screen cleaning system.
  - Inspect spray orifices for fouling and erosion and whether the water or air spray systems need to be enlarged.



- Inspect screen faces for undulations in the screen material that may reduce cleaning efficiency (i.e., for traveling brush systems).
  - Inspect screen cleaning brushes for wear and deterioration (e.g., for traveling brush systems).
  - Inspect seals for wear and deterioration.
  - Assess the overall efficiency of the cleaning system and identify any recommended solutions in the inspection report.
  - Inspect underwater moving parts for corrosion and damage.
- Inspect the morphology of the stream channel in the immediate vicinity of the project for debris, erosion, and sedimentation that may potentially damage screens and their supporting structures or adversely affect screen operation and effectiveness.
- If warranted, measure water velocities perpendicular to the screen face to determine flow uniformity over all screen surfaces. Above normal debris accumulation in small areas may indicate approach velocities exceed the design criteria in those locations. Excessively high approach velocities can result in debris accumulation. If the accumulation is not addressed in a timely manner it may result in less efficient water withdrawal and eventual damage to the screen material or its structure.
- Test backup systems and alarms that could include the following:
  - Pump shut-off controls
  - Blow out panels
  - Mechanical brush shut-off system controls
  - Screen cleaning system failure alarms

# 9 Operations and Maintenance

## 9.1 Introduction

The design criteria and guidance provided in this document were developed to produce a high level of effectiveness and reliability at installed fish passage and protection facilities. Achieving this requires that these facilities be operated and maintained properly to optimize their performance in accordance with the design objectives of the facility. Failure to do so is a key concern of NMFS. This is because insufficient attention to the operational and maintenance aspects of a facility can compromise its fish passage effectiveness and result in fish injury and mortality.

This chapter addresses O&M issues in general and describes the components needed in a facility O&M plan. Where necessary, other chapters of this document will also address O&M issues that apply specifically to the topics covered in those chapters (e.g., Chapters 5 and 8).

## 9.2 General Criteria

*Passage and screening facilities at barriers, diversions, water intakes, traps, and collection facilities should be operated and maintained in accordance with the O&M plan over the entire life of the project. This is needed to meet the mechanical design and biological objectives of the facility and the goal of providing optimal conditions for fish that result in successful passage (i.e., no mortality and minimal injury and delay).*

NMFS requires that facility owners and operators commit to accepting responsibility for installing and properly operating, maintaining, and repairing the fish passage facilities described in the Guidelines. This is to ensure that: 1) fish affected by the facility are protected in a manner that is consistent with the intended performance of the facility based on its design; and 2) fish protection is provided on a sustained basis. For example, the proper function and operation of a fish passage facility would need to be restored immediately after damage from flooding and prior to the arrival of migratory fish, including repairing damaged structures and removing accumulated gravel and sediment.

Where facilities are inadequately operated or maintained, and the injury or mortality of listed fish can be documented, the responsible party is liable to enforcement measures as described in Section 9 of the ESA.

## 9.3 Specific Criteria – Staff Gages

*Staff gages should be installed and maintained at critical locations throughout the facility.*

Staff gages allow personnel to quickly determine if the facility is being operated within the established design criteria. Staff gage locations will be identified in the O&M plan.

## **9.4 The Operations and Maintenance Plan**

This section describes how O&M plans are developed and approved and their contents.

### **9.4.1 O&M Plan Development and Approval**

*The O&M plan for a facility should be submitted to and accepted by NMFS prior to initiating project construction. The design of facilities should be made in consideration of O&M requirements and vice versa. Therefore, O&M plans need to be developed during the planning and design processes and must be reviewed and approved by NMFS at this time, along with project design documents.*

For new facilities, it is recommended that a description of intended operations be obtained from the designer and then incorporated into the O&M plan. Such a description is often referred to as the “designer’s intent.”

The complexity of the O&M plan should reflect the complexity of the facility it addresses. For example, a facility with complex components, narrow operating requirements, and sophisticated water control systems will require a detailed plan that addresses all of the components, systems, and operational scenarios. This should include potential emergency scenarios, including the identification of spare parts for essential components that need to be on hand in case of failure.

### **9.4.2 Group O&M Plans**

*Comprehensive O&M plans for a group of projects will satisfy the requirement for an O&M plan for each project in the group as long as NMFS is in agreement with the O&M of the passage facilities.*

Examples of group projects include road maintenance plans for culverts and small screen facilities within a network of water diversions.

### **9.4.3 General**

*The O&M plan should include the following criteria, procedures, and staffing requirements.*

#### **9.4.3.1 Facility operating criteria**

*The O&M plan should list the facility operating criteria. This includes (but is not limited to) criteria for water levels at critical locations, gate operations, gate settings, how the system is adjusted to accommodate changes in forebay and tailwater levels, and inspection procedures and frequency (e.g., daily, monthly, and annually).*

#### **9.4.3.2 Procedures**

*The O&M plan should include a description of routine O&M procedures. In addition, the O&M plan should include procedures for dewatering the facility, salvaging fish during a dewatering event, sediment and debris removal, and emergency operations.*

Procedures, such as dewatering plans, fish salvage plans, and emergency operations, can have a direct impact on the survival of fish in the facility. It is important that these procedures be incorporated into O&M plans and operators are familiar with them in order to minimize any adverse impacts.

#### **9.4.3.3 Staffing requirements**

*The O&M plan should discuss the staffing requirements needed to support the O&M plan, including the hours staff are required to be on site to monitor and operate the facility. The staffing requirement component of the plan should incorporate automatic controls and telemetry into the O&M plan and facility that notify operators of problems to increase overall reliability of the facility.*

#### **9.4.4 Posting the O&M Plan**

*The O&M plan should be posted at the facility or otherwise made available to the facility operator. Operators should be familiar with and understand the O&M plan and operate the facility accordingly.*

It is important that the O&M plan be available and easily accessed by the facility operator should questions or emergency situations arise.

#### **9.4.5 Periodic Review of O&M Plans by NMFS**

*Operations and maintenance documents should be reviewed and revised (with NMFS involvement) annually for the first 3 years of operation and then periodically after that as conditions and operations dictate.*

NMFS intends that O&M plans be “living” documents. O&M documents should be revised periodically as the owner and operator develop more experience with a new facility. This is important because over time, experience will be gained as to how the facility performs under various hydrologic and environmental conditions, and ideas on how to improve the O&M of the facility will develop. For example, it is important that facility owners and operators note areas in the O&M plan that are deficient or need revision.

## 10 References

- AECOM (AECOM, Inc.). 2009. Upper Baker Floating Surface Collector Field Verification Testing – Spring 2009. Draft report prepared for Puget Sound Energy, Bellevue, Washington, dated May 2009. Document No.:05570-053-0410.
- Barnard, R. J., J. Johnson, P. Brooks, K. M. Bates, B. Heiner, J. P. Klavas, D.C. Ponder, P.D. Smith, and P. D. Powers. 2013. Water Crossings Design Guidelines, Washington Department of Fish and Wildlife, Olympia, Washington.
- Bates, K. 1992. Fishway Design Guidelines for Pacific Salmon. Washington Department of Fish and Wildlife, Olympia, Washington.
- Bell, M.C. 1991. Fisheries Handbook of Engineering Requirements and Biological Criteria. Fish Passage and Development Evaluation Program, U.S. Army Corps of Engineers, Portland, Oregon.
- Blackett, R. 1987. Development and Performance of an Alaska Steeppass Fishway for Sockeye Salmon (*Oncorhynchus nerka*). Canadian Journal of Fisheries and Aquatic Science 44:66-76.
- BOR (U.S. Bureau of Reclamation). 2006. Fish Protection at Water Diversions: A Guide for Planning and Designing Fish Exclusion Facilities. Water Resources Technical Publication U.S. Department of the Interior, Bureau of Reclamation, Denver, Colorado.
- Bottom, D., K. Jones, C. Simenstad, and C. Smith. 2011. Reconnecting Societal and Ecological Resilience in Salmon Ecosystems. Oregon Sea Grant Report ORESO-B-11-001. In Pathways to Resilience; Sustaining Salmon Ecosystems in a Changing World Ecology and Society 14(1):5.
- Brett, J., and D. Alderdice. 1953. Research on Guiding Young Salmon at Two British Columbia Field Stations. Bulletin No. 117, Fisheries Research Board of Canada.
- Brett, J.R., M. Hollands, and D.F. Alderdice. 1958. The effects of temperature on the cruising speed of young sockeye and coho salmon. Journal of the Fisheries Research Board of Canada 15:587-605.
- Brownell, P., S. McDermott, A. Haro, F. Rohde, J. Johnson, A. Blott, B. Rizzo, Undated. Diadromous Fish Passage: A Primer on Technology, Planning, and Design for the Atlantic and Gulf Coasts. Available from NOAA National Marine Fisheries Service Southeast Region, Habitat Conservation Division.
- Castro, J.M. and P.L. Jackson, 2001. Bankfull Discharge Recurrence Intervals and Regional Hydraulic Geometry Relationships: Patterns in the Pacific Northwest, USA. Journal of the American Water Resources Association 37(5):1249-1262, doi: 10.1111/j.1752-1688.2001.tb03636.x.
- CDFG (California Department of Fish and Game). 2002. Culvert Criteria for Fish Passage, California Department of Fish and Game, May 2002.
- Cech, J., P. Young, C. Swanson, M. Levent Kavvas, Z. Chen, and H. Bandeh. 2001. Fish Treadmill-Developed Fish Screen Criteria for Native Sacramento-San Joaquin Watershed Fishes, Final Report, CALFED Bay/Delta Program, CALFED Project 99-N02.

- Clay, C.H. 1961. Design of Fishways and Other Fish Facilities. Department of Fisheries of Canada, Queen's Printer, Ottawa, Canada.
- Clay, C.H. 1995. Design of Fishways and Other Fish Facilities. Second Edition. Boca Raton: CRC Press.
- Collins, G.B. 1976. Effects of Dams on Pacific Salmon and Steelhead Trout. *Marine Fisheries Review* 38(11):39-45.
- Cooper, R.M. 2005. Estimation of Peak Discharges for rural, Unregulated Streams in Western Oregon: U.S. Geological Survey Scientific Investigations Report 2005-5116, 134 p.
- DOI (U.S. Department of Interior). 1987. Design of Small Dams. 3rd Edition. Water Resources Technical Publications, Washington D.C.
- EPRI (Electric Power Research Institute). 1994. Fish Protection/Passage Technologies Evaluated by EPRI and Guidelines for Their Application. EPRI TR-104120s.
- FERC (Federal Energy Regulatory Commission). 1995. Impacts of Hydroelectric Plant Tailraces on Fish Passage: A Report on Effects of Tailraces on Migratory Fish and Use of Barriers, Modified Project Operations, and Spills for Reducing Impacts. Paper No. DPR-9. Office of Hydropower Licensing, Washington, D.C.
- Gauley, J., C. Weaver, and C. Thompson. 1966. Research on Fishway Problems May 1960 to April 1965. Third Progress Report on Fisheries Engineering Research Program, North Pacific Division. U.S. Army Corps of Engineers, Portland, Oregon.
- Gotvald, A.J., N.A. Barth, A.G. Veilleux, and C. Parrett. 2012. Methods for Determining Magnitude and Frequency of Floods in California, Based on Data Though Water Year 2006. U.S. Geological Survey Scientific Investigations Report 2012-5113. Available online only at <http://pubs.usgs.gov/sir/2012/5113/>.
- Hanna, L. 2011. ISI Cone Screen Performance in a Riverine Environment, PAP-1037. U.S. Department of Interior, Bureau of Reclamation, Technical Service Center, Hydraulic Investigations & Laboratory Services, Denver, Colorado. PAP-1037.
- Hanna, 2013. ISI Cone Screen Riverine Performance with an External Baffle. U.S. Department of Interior, Bureau of Reclamation, Technical Service Center, Hydraulic Investigations & Laboratory Services, Denver, Colorado. PAP-1081.
- Hanski, I. 1998. Metapopulation dynamics. *Nature* 396:41-49.
- Haro, A., M. Odeh, J. Noreika, and T. Castro-Santos. 1998. Effect of water acceleration on downstream migratory behavior and passage of Atlantic salmon smolts and juvenile American shad at surface bypasses. *Trans. Am. Fish. Soc.* 127:118-127.
- Hevlin, W., and S. Rainey. 1993. Considerations in the Use of Adult Fish Barriers and Traps in Tributaries to Achieve Management Objectives. Pages 33-40 in K. Bates, compiler. *Fish Passage Policy and Technology*. Bioengineering Section, American Fisheries Society, Bethesda, Maryland.
- Hilborn, R., T.P. Quinn, D.E. Schindler, and D.E. Rogers. 2003. Biocomplexity and fisheries sustainability. *Proc. Nat. Acad. Sci.* 100:6564-6568.
- HSRG (Hatchery Scientific Review Group). 2009. Report to Congress on Columbia River Basin Hatchery Reform.

- Johnson, G., B. Ebberts, D. Dauble, A. Giorgi, P. Heisey, R. Mueller, and D. Neitzel. 2003. Effects of jet entry at high-flow outfalls on juvenile Pacific salmon. *North American Journal of Fisheries Management* 23:441-449.
- Katopodis, C. 1992. *Introduction to Fishway Design*. Freshwater Institute, Central and Arctic Regions, Department of Fisheries and Oceans, Winnipeg, Manitoba, Canada.
- Lang, M., and M. Love. 2014. *Comparing Fish Passage Opportunity Using Different Fish Passage Design Flow Criteria in Three West Coast Climate Zones*. Contract Report for National Marine Fisheries Service. Humboldt State University and Michael Love & Associates, Inc., Arcata, California, August 2014.
- Larinier, M., F. Travade, and J. Porcher. 2002. Fishways: biological basis, design criteria and monitoring. *Bulletin Français de la Pêche et de la Pisciculture* 364 suppl.:135-146.
- Larinier, M., and F. Travade. 2002. The design of fishways for shad. *Bulletin Français de la Pêche et de la Pisciculture* 2002 364 suppl.:135-146.
- Lindley, S.T., R.S. Schick, E. Mora, P.B. Adams, J.J. Anderson, S. Greene, C. Hanson, B. May, D. McEwan, R.B. MacFarlane, C. Swanson, and J.G. Williams. 2007. Framework for Assessing the Viability of Threatened and Endangered Chinook Salmon and Steelhead in the Sacramento-San Joaquin Basin. *San Francisco Estuary and Watershed Sciences* 5:1. Available at <http://repositories.cdlib.org/jmie/sfew/vol5/iss1/art4>.
- Love, M., and K. Bates. 2009. Part XII: Fish Passage Design and Implementation. *California Salmonid Stream Habitat Restoration Manual*. California Dept. of Fish and Game. 188 pages.
- Manning, D., J. Mann, R. Benkert, S. Chase, and S. White. 2005. Steelhead emigration in a seasonal impoundment created by an inflatable rubber dam. *North American Journal of Fisheries Management* 25:1239-1255.
- McClure, M., T. Cooney, and M. Marvier. 2001. Assessing the role of dams in salmon recovery. *Hydro. Rev.* 20:36-45.
- McElhany, P., M. Ruckelshaus, M. Ford, T. Wainwright, and E. Bjorkstedt. 2000. Viable Salmonid Populations and the Recovery of Evolutionarily Significant Units. NOAA Technical Memorandum NMFS-NWFSC-42. Available online at <http://www.nwfsc.noaa.gov/publications/>.
- McLaughlin, R., A. Hallett, T. C. Pratt, L.M. O'Connor, and D.G. McDonald. 2007. Research to guide use of barriers, traps, and fishways to control sea lamprey. *J. Great Lakes Res.* 33:27-19.
- Mooney, D., C. Holmquist-Johnson, and E. Holburn. 2007. *Reclamation Managing Water in the West: Qualitative Evaluation of Rock Weir Field Performance and Failure Mechanisms*. U.S. Bureau of Reclamation, Technical Service Center, Denver, Colorado.
- Mueller, R., D. Neitzel, and C. Abernethy. 1995. *Fisheries Evaluation of the Dryden Fish Screening Facility*. Project No. 1985-06200, Prepared by the Pacific Northwest Laboratory for the Division of Fish and Wildlife, Bonneville Power Administration, Portland, Oregon. BPA report DOE/BP-00029-2.
- Neitzel, D., C. Abernethy, and E. Lusty. 1990a. *A Fisheries Evaluation of the Westside Ditch and Wapato Canal Fish Screening Facilities, Spring 1989*. Prepared by the Pacific Northwest Laboratory for the Division of Fish and Wildlife, Bonneville Power Administration, Portland, Oregon.

- Neitzel, D.A., C.S. Abernethy, and E.W. Lusty. 1990b. A Fisheries Evaluation of the Wapato, Sunnyside, and Toppenish Creek Canal Fish Screening Facilities, Spring 1988. Prepared by Pacific Northwest Laboratory, Richland, Washington, for U.S. Department of Energy, Bonneville Power Administration, Yakima, Washington.
- NMFS (National Marine Fisheries Service). 2001. Guidelines for Salmonid Passage at Stream Crossings. National Marine Fisheries Service Southwest Region. September 2001. Available at: [http://www.westcoast.fisheries.noaa.gov/publications/hydropower/fish\\_passage\\_at\\_stream\\_crossings\\_guidance.pdf](http://www.westcoast.fisheries.noaa.gov/publications/hydropower/fish_passage_at_stream_crossings_guidance.pdf).
- NMFS. 2006. Comments, Recommended Terms and Conditions, and Prescription for Santa Felicia Hydroelectric Project, FERC Project No. 2153-012. Letter of R.R. McInnis, to M.R. Salas, Federal Energy Regulatory Commission, Washington, D.C., December 14, 2006.
- NMFS. 2014. Public Final Recovery Plan for the Evolutionary Significant Units of Sacramento River Winter-run Chinook Salmon and Central Valley Spring-run Chinook Salmon and the Distinct Population Segment of Central Valley Steelhead. Sacramento Protected Resources Division, Sacramento, California.
- Northcote, T.G. 1998. Migratory Behavior of Fish and Its Significance to Movement through Riverine Fish Passage Facilities. Fish Migration and Fish Bypasses. In: Fish Migration and Fish Bypasses. Blackwell Science Ltd. Publishers, Oxford, U.K.
- NRC (National Research Council). 1996. Upstream: Salmon and Society in the Pacific Northwest. National Academy Press, Washington, D.C.
- NRCS (Natural Resources Conservation Service). 2007. Technical Supplement 14A. Part 654 National Engineering Handbook. Soil Properties and Special Geotechnical Problems Related to Stream Stabilization Projects. Available online at: <http://directives.sc.gov.usda.gov/OpenNonWebContent.aspx?content=17810.wba>.
- Peterson, D., and P. Mohanty. 1960. Flume Studies of Flow in Steep, Rough Channels. Journal of the Hydraulic Division. Proceedings of the American Society of Civil Engineers Vol. 86:55-76.
- Powers, P., and J. Orsborn. 1985. New Concepts in Fish Ladder Design: Analysis of Barriers to Upstream Fish Migration, Volume IV of IV. Investigation of the Physical and Biological Conditions Affecting Fish Passage Success at Culverts and Waterfalls. Project No. 198201400, BPA Report DOE/BP-36523-1.
- Quinn, T.P. 2005. The Behavior and Ecology of Pacific Salmon and Trout. Seattle: University of Washington Press.
- Rajaratnam, N., and C. Katopodis. 1984. Hydraulics of Denil Fishways. J. Hydraul. Eng. 110(9):1219-1233.
- Rideout, S., L. Thorpe, and L. Cameron. 1985. Passage of American Shad in an Ice Harbor style fish Ladder after Flow Pattern Modifications. Proceedings of the Symposium on Small Hydropower and Fisheries, pages 251-256. F. Olsen, R. White, and R. Hamre, editors. Published by the American Fisheries Society, Bethesda, Maryland.
- Roff, D.A. 1992. The Evolution of Life Histories: Theory and Analysis. New York: Chapman and Hall.



- Ruckelshaus, M.H., P.S. Levin, J.B. Johnson, and P. Kareiva. 2002. The Pacific salmon wars: what science brings to the challenge of recovering species. *Annual Review of Ecology and Systematics* 33:665-706.
- Ruggles, C.P., and P. Ryan. 1964. An Investigation of Louvers as a Method for Guiding Juvenile Pacific Salmon. Department of Fisheries Canada, Vancouver, British Columbia.
- Sayre, W., and M. Albertson. 1963. Roughness spacing in rigid open channels. *Transactions of the American Society of Civil Engineers* 128(1):343-371.
- Schindler, D.E., R. Hilborn, B. Chasco, C.P. Boatright, T.P. Quinn, L.A. Rogers, and M.S. Webster. 2010. Population diversity and the portfolio effect in an exploited species. *Nature* 465:609-613.
- Senn, H., J. Mack, and L. Rothfus. 1984. Compendium of Low-cost Pacific Salmon and Steelhead Production Facilities and Practices in the Pacific Northwest. Project No. 83-353. Report to the Bonneville Power Administration, Portland, Oregon.
- Shively, R.P., T.P. Poe, and M.B. Sheer. 1996. Criteria for reducing predation by northern squawfish near juvenile salmonid bypass outfalls at Columbia River dams. *Regulated Rivers: Research and Management* 12:493-500.
- Slatick, E. 1975. Laboratory evaluation of a Denil-type steep pass fishway with various entrance and exit conditions for passage of adult salmonids and shad. *Marine Fisheries Review* 37(9):17-26.
- Slatick, E., and C. Wagner. 1989. Criteria for a Velocity-Barrier Dam for Migrating Adult Salmonids. Northwest and Alaska Fisheries Center, Seattle, Washington.
- Smith, L., and L. Carpenter. 1987. Salmonid Fry Swimming Stamina Data for Diversion Screen Criteria. Final Report, Fisheries Research Institute, University of Washington, Seattle, Washington.
- Stanford, J.A., J.V. Ward, W.J. Liss, C.A. Frissell, R.N. Williams, J.A. Lichatowich, and C.C. Coutant. 1996. A General Protocol for Restoration of Regulated Rivers. *Regulated Rivers: Research & Management* 12(4-5):391-413.
- Stewart, R. 2003. Techniques for Installing a Resistance Board Fish Weir. Regional Information Report No. 3A03-26. Alaska Dept. of Fish and Game, Anchorage, Alaska.
- Taylor, E.B. 1991. A review of local adaptation in Salmonidae, with particular reference to Pacific and Atlantic salmon. *Aquaculture* 98:185-207.
- Thompson, C., W. Davis, and E. Slatick. 1967. Response of Migrating Adult Salmonids to Vertical and Horizontal Rectangular Orifices at Two Depths. U.S. Fish and Wildlife Service Special Scientific Report No. 547.
- Tobin, J. 1994. Construction and Performance of a Portable Resistance Board Weir for Counting Migrating Adult Salmon in Rivers. U.S. Fish and Wildlife Service, Alaska Fisheries Technical Report Number 22.
- USFWS (U.S. Fish and Wildlife Service). 1960.
- USFWS. 2017. *Pacific Lamprey Technical Workgroup*. Practical guidelines for incorporating adult Pacific lamprey passage at fishways. June 2017. White Paper. Appendix.
- Wagner, C. 1967. Fish Barrier Dams: Fish Facilities Section Memo Dated August 23, 1967. Columbia Fisheries Program Office, Bureau of Commercial Fisheries, Portland, Oregon.

- Waples, R.S. 1991. Definition of "species" under the Endangered Species Act: Application to Pacific Salmon. U.S. Department of Commerce, National Oceanic and Atmospheric Administration Technical Memorandum. NMFS F/NWC-194.
- Ward, J., and J. Stanford. 1979. *The Ecology of Regulated Streams*. New York: Plenum Press.
- WDFW (Washington Department of Fish and Wildlife). 2000. *Fishway Guidelines for Washington State*. Draft Report dated April 25, 2000. Washington Department of Fish and Wildlife, Olympia, Washington.
- Weaver, C., C. Thompson, and E. Slatick. 1976. *Fish Passage Research at the Fisheries-Engineering Research Laboratory May 1965 to September 1970*. Report No. 32 In: *Fourth Progress Report On Fisheries Engineering Research Program, 1966-1972*. U.S. Army Corps of Engineers, North Pacific Division, Portland, Oregon.
- Weaver, C. 1963. Influence of water velocity upon orientation and performance of adult migrating salmonids. U.S. Fish and Wildlife Service. *Fish. Bull.* 63:97-121.
- World Commission on Dams. 2000. *Dams and Development: and New Framework for Decision-making*. London: Earthscan Publications.
- Yoshiyama, R.M., E.R. Gerstung, F.W. Fisher, and P.B. Moyle. 1996. Historical and Present Distribution of Chinook Salmon in the Central Valley Drainage of California. In: *Sierra Nevada Ecosystem Project: Final Report to Congress, Volume III*. Centers for Water and Wildland Resources, University of California, Davis. Davis, California, pp. 309-361.
- Ziemer, G. 1962. *Steeppass Fishway Development*. Information Leaflet 12. Alaska Department of Fish and Game.
- Zimmerman, C.E., and L.M. Zabkar. 2007. Weirs, Chapter 6 in *Salmonid Field Protocols Handbook*, pp 385-398. American Fisheries Society, Bethesda, Maryland.