

# **Using the Rolling-Period Test to Estimate Stability in Small Fishing Vessels**

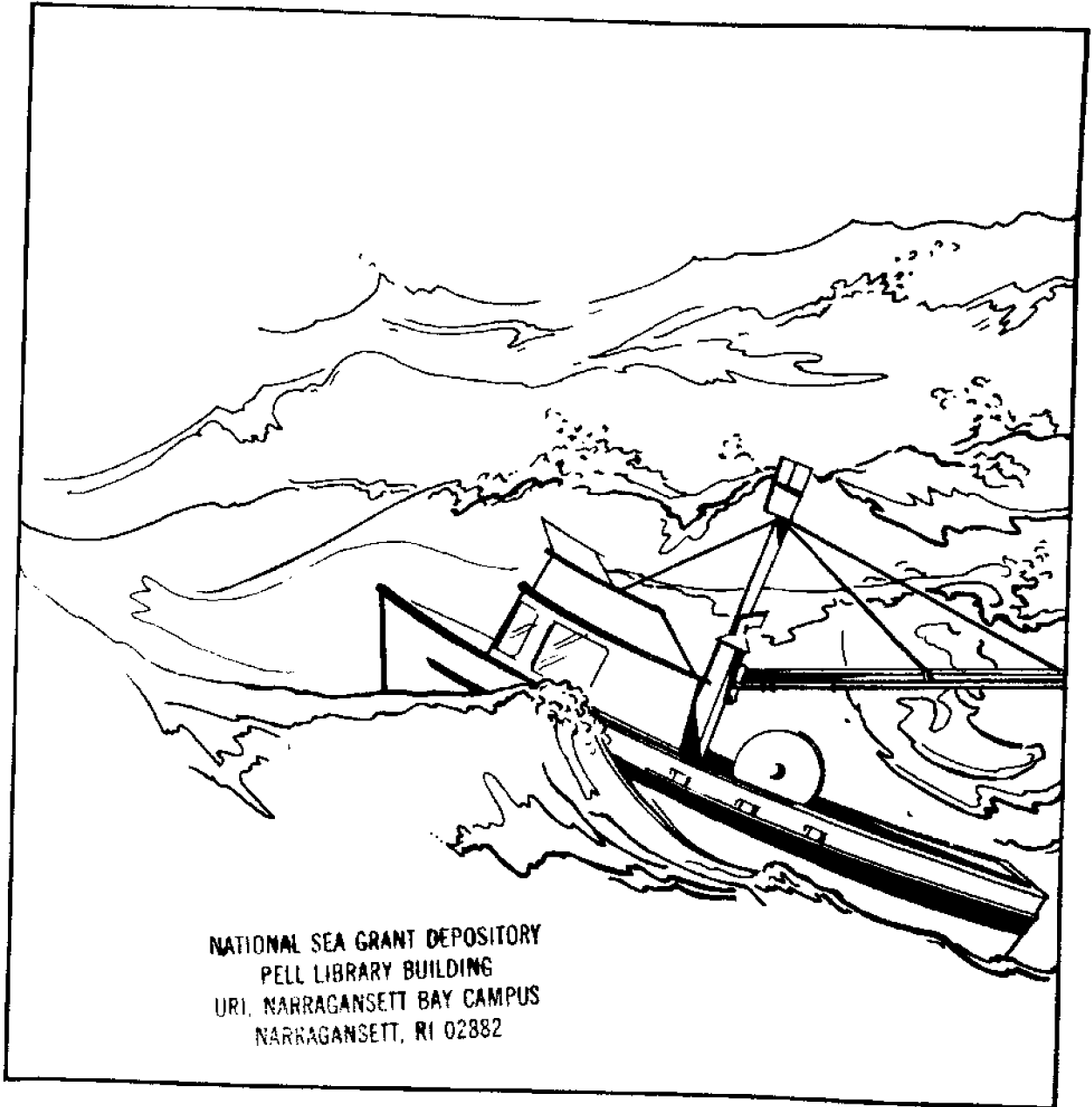

Special Report 779 / August 1986

**Oregon State University Extension Service**

NATIONAL SEA GRANT DEPOSITORY  
PELL LIBRARY BUILDING  
URI, NARRAGANSETT SEY CAMPUS  
NARRAGANSETT, RI 02882

---

at Oregon State University, Robert T. Hudspeth is professor of civil engineering; Fred Mazenot is research assistant, Department of Civil Engineering; W. G. Carter is Extension marine agent, Multnomah County; and Thomas H. Gentle is Extension communication specialist. In the late 1970's, OSU Extension oceanographer Edward J. Condon (now deceased) recognized the need for a simple method of estimating small vessel stability. His efforts prompted the inquiry into a rolling-period measurement. The rolling-period test outlined in this publication is based on the one established by the Intergovernmental Maritime Consultative Organization (IMCO); Hudspeth and Mazenot adapted it for West Coast fishing vessels up to 80 feet long.

## Using the Rolling-Period Test To Estimate Fishing Vessel Stability

R. T. Hudspeth, F. Mazenot, W. G. Carter, and T. H. Gentle

The rolling period test described in this publication is intended to provide a reasonable estimate of the stability of fishing vessels up to 80 feet in length when boat owners can't easily carry out inclining tests. The rolling-period test provides information to calculate the metacentric height of your vessel, a measure of its stability (more on that later).

Why should you conduct a rolling-period test on your vessel? Generally speaking, a fishing vessel is designed so that it has a safe level of stability. However, the stability may change because of equipment you've installed on your vessel or because of other modifications.

If you suspect that the stability of your vessel has changed because of modifications you or others have made, the test described in this publication will give you a quick and reasonably accurate estimate of your fishing vessel's stability.

If you have stability figures from a previous test--but have modified your vessel in the meantime--a comparison of the old stability figure with the one from the rolling-period test will indicate how the modifications may have changed your boat's relative stability.

What kind of modifications may affect the stability of your vessel? Basically, they're either changes in the boat's structure or adding weight--for example, adding new fishing gear or changing engines.

Finally, no matter what historical stability data you already have on your vessel--and whether or not you've made any changes--you should conduct a rolling period test now to give yourself a stability standard for comparison, in case you make changes later.

The rolling-period test involves rolling your vessel until it is rolling well and measuring the time it takes for the vessel to roll one complete period from one side to the other and back again. The metacentric height of your vessel is mathematically related to this roll period. (See figure 1.) The metacentric height is the distance from the center of gravity to the intersection of two vertical lines (m), one of which passes through the center of buoyancy (B) when the ship is in equilibrium, the other through the center

of buoyancy when the hull is inclined slightly to one side ( $B^1$ ). The distance of this intersection above the center of gravity is an indication of the initial stability of the hull.)

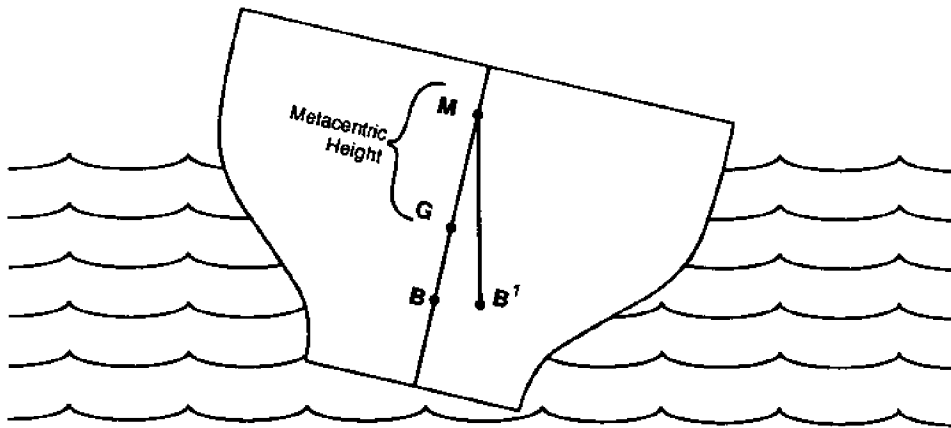

Figure 1 M, Metacenter of a boat; G, center of gravity; B, center of buoyancy; B<sup>1</sup>, Center of buoyancy when boat is displaced.

This publication describes the test conditions and the procedures to conduct a rolling period test. The more closely you observe them, the more reliable your results will be.

Notice that we said the rolling period test provides a reasonably accurate estimate, or an approximation, of vessel stability. That's because the rolling-period test is not the most accurate way to determine vessel stability.

The inclining test, which involves what is called a line's plan or table of offsets, gives the best measurement of vessel stability. However, these tests are expensive--and if you do not have line's plans for your vessel, they're also expensive to develop.

You'll need three measurements to conduct your rolling period test:

1. the maximum length of your vessel (A in figure 2);
2. the minimum freeboard of your vessel (B in figure 2); and
3. the maximum beam of your vessel (figure 3).

These measurements are used to calculate the metacentric height.

The maximum length of a vessel includes bowsprits or catwalks that extend from the bow. Minimum freeboard is measured amidship from the waterline to the top of the main deck.

#### Vessel-loading conditions

1. Load your vessel with all the gear and supplies that would be aboard when you head for the fishing grounds. Place gear, equipment and supplies at the locations on board where you would usually stow them.

2. Watch especially for heavy objects that are likely to swing or slide as the vessel rolls back and forth. Secure them against such movement. Minimize the free surface effects of slack tanks (fill the tanks or pump them as dry as possible).

#### Environmental conditions

Wind. Don't conduct the test on a windy day when the wind could cause the boat to heel during the test. Generally, the wind should be less than 4 knots. A relatively strong wind (11 to 16 knots) is acceptable if it is blowing from dead ahead or dead astern (figure 4).

Current. Under ideal conditions, the test should take place in a closed dock. Don't conduct the test in areas that are known to have strong currents. To avoid the effect of tidal currents, conduct the test during slack tides, or moor in a position so that any small current runs from dead ahead to dead astern (similar to the direction of the wind in figure 4).

Waves. The influence of naturally occurring waves or those caused by another boat can alter the test and make the results invalid. Ideally, the water should be flat calm. Wavelets that don't cause the vessel to roll on its own are acceptable.

Space around vessel. There must be no physical contact between the boat and the pier or the bottom. We recommend both a minimum distance of 2 feet between the side of the boat and the pier and a minimum distance of 2 feet between the keel and the bottom (figure 5). Any contact with the dock or the bottom would affect the validity of the rolling period test.

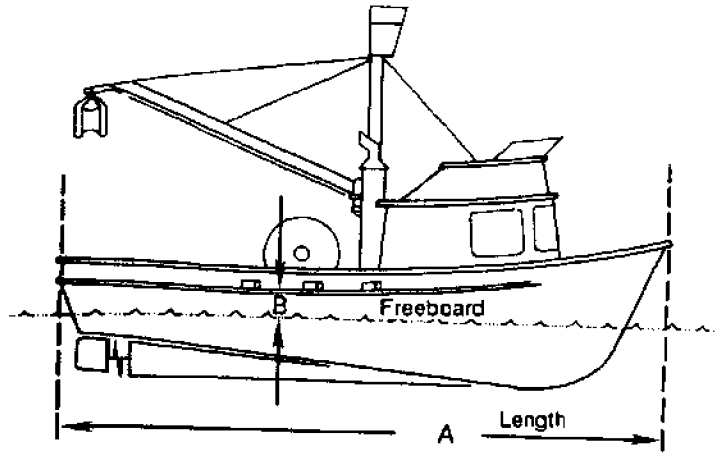

Figure 2

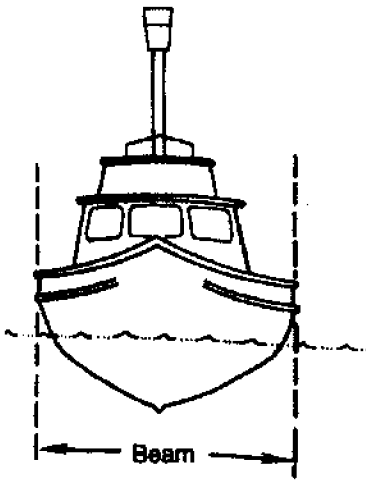

Figure 3

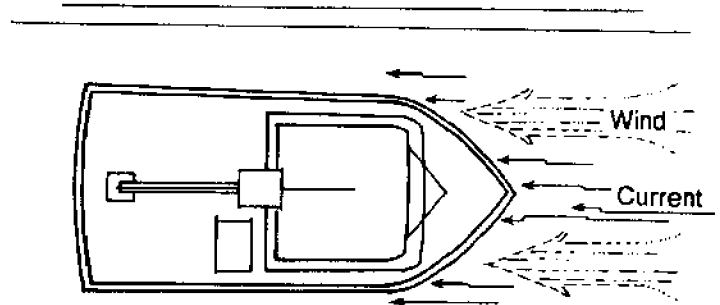

Figure 4

### Mooring conditions

Ideally, your boat should be free of mooring lines during the rolling period test. If this isn't possible, attach the mooring lines on the centerline at the bow and stern. During the actual test, be sure to let the mooring lines go slack (figure 6).

### Rolling the boat

You can cause your vessel to roll by:

1. having people step in unison from the dock on and off the boat;
2. having people run back and forth across the deck together;
3. pulling on a rope tied high up on the mast; or
4. lifting a heavy load up and down on deck with the vessel's crane or a dockside crane.

### Test starting conditions

Depending on how you roll your boat to start the test, you must meet certain conditions during the actual measurements.

1. If people step back and forth from the dock to the deck, they must stay on the dock before you start timing.
2. If people run back and forth on deck, they must go to the centerline of the boat and remain in place before you start timing.
3. If you use a rope tied to the mast to roll the boat, let the rope go slack before you start timing.
4. If you use a dockside crane to lift a heavy load up and down, the load must be removed from the deck before you start timing.
5. If you use the vessel's crane to offset a heavy load, the derrick must be fixed in place on the centerline before you start timing.

Before starting the test, you need to make a temporary mark on your hull at a point amidship (figure 7). When your boat is rolling during the test, this mark should not go below the surface of the water. If it does, your boat is rolling too much and the test results will not be valid.

You determine where to place this temporary mark by dividing your vessel's maximum beam in feet by 8. Using the value obtained from this calculation, measure at a point amidship from the waterline up the side of the hull and

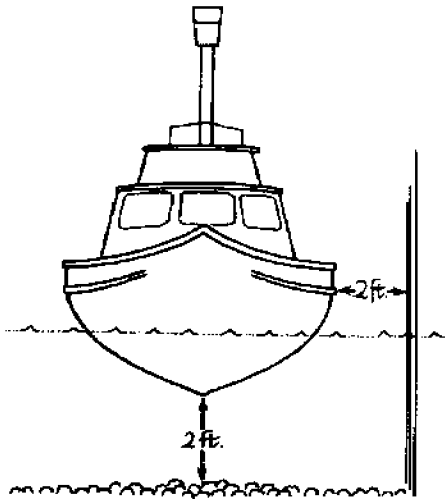

Figure 5

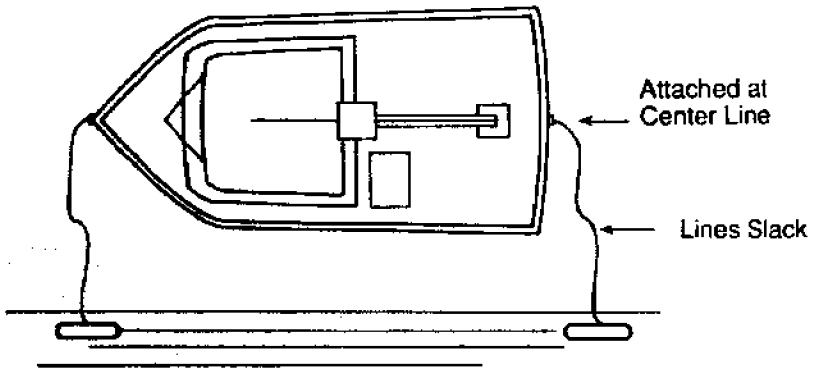

Figure 6

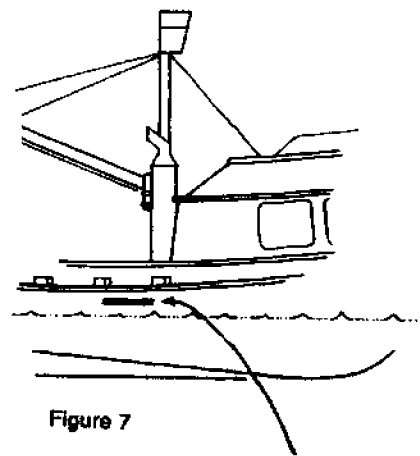

Figure 7

Temporary mark on hull



make a temporary mark (colored chalk or a piece of tape is recommended).

For example, if the maximum beam is 20 feet, divide 20 by 8, which equals 2.5 feet. In this case, you would make a mark on your hull 2.5 feet above the waterline.

Once you have placed this mark on the hull, check to be sure your vessel meets the loading and environmental conditions described earlier:

- \* Fishing gear and supplies are in their customary places and tied down.
- \* The free-surface effects of slack tanks are minimized. Ideally, all tanks should be full or empty.
- \* Wind, wave, and current conditions are acceptable.
- \* The mooring lines are slack.

#### Timing

1. You should have two people with stopwatches measuring the rolling periods. Preferably, one person should stand on the dock, the other on the boat.

2. Starting with the vessel at the extreme end of a roll to one side (say, port) and the vessel about to move towards the upright, one complete rolling period will have been made when the vessel has moved to the other extreme side (that is, starboard), has returned to the original starting point, and is about to begin the next roll.

Using a stopwatch, time four complete rolling periods. Start the stopwatch at the beginning of the first rolling period and stop it at the end of the fourth rolling period.

3. After you have timed one series of four rolling periods, roll the boat again and time another series of four rolling periods. For the stability calculations given in this publication, we recommend that you repeat each series of four rolling periods three times.

How big a team will you need for your test? As we recommended, you'll need two people to act as timers (one on the vessel, the other on the dock). Then you'll need three or four more to roll the boat by stepping from the dock to the deck and back, running back and forth across the deck, or pulling a rope tied to the mast. If you plan to lift a heavy load on and off the deck

with a dock or deck crane, add one more person to operate it. Finally, pick one person who will announce when to begin timing and when to stop.

Before you start the actual timed test, rehearse the test procedure so that your team members know what they are supposed to do.

Now you are ready to begin.

Start rolling your boat. Once it's rolling freely, be sure the roll does not submerge the temporary mark you placed on the hull. Before you begin timing, allow one rolling period to elapse.

After your "announcer" gives the command to start timing, he or she will count four complete rolling periods and then tell the timers to stop their watches.

Repeat the measurement of four rolling periods until you have a total of three sequences. Each sequence requires a fresh start. Before timing each sequence, you must start the boat rolling again by whatever method you used. Record your results in the following table:

Timer #1

Time in seconds of first complete rolling period sequence T1\_\_\_\_\_

Time in seconds of second complete rolling period sequence T2\_\_\_\_\_

Time in seconds of third complete rolling period sequence T3\_\_\_\_\_

Timer #2

Time in seconds of first complete rolling period sequence T4\_\_\_\_\_

Time in seconds of second complete rolling period sequence T5\_\_\_\_\_

Time in seconds of third complete rolling period sequence T6\_\_\_\_\_

Total seconds: \_\_\_\_\_

Now that you have timed the rolling period of your boat, you are ready to begin the calculations that will give you an estimate of its metacentric height.

Calculating your rolling period

To calculate the time of one rolling period T--the time it takes for the

boat to roll from port to starboard and back to port--divide the total seconds above by 24:

$$T = \frac{\text{Total seconds}}{24}$$

Now that you have calculated the time of one rolling period, you are ready to compute the metacentric height of your vessel. (The symbol for metacentric height is represented mathematically by the symbol GM.) Use this formula to calculate metacentric height:

$$GM = \frac{(f \times f \times B \times B)}{(T \times T)}$$

In this formula, B is the maximum beam of your vessel in feet.

T is the average time of one rolling period

$$\underline{f} = 0.4$$

The f in the formula stands for a special value characteristic of your boat. This value varies from boat to boat, and it's one of the items that the more-expensive inclining test would provide. Here we are using the average f rating of 0.4 that is typical of flat-bottomed, high-bow fishing vessels up to 80 feet long (based on a National Marine Institute study of these vessels). Use this average figure in your own calculations--unless you have an f value for your vessel from an inclining test.

Let's look at an example involving two sister fishing vessels. Vessel 1 is 70 feet long, with 21.92 feet in maximum beam. Vessel 2 is 70 feet long, but its beam was widened to 24.67 feet to improve its stability.

#### Vessel 1

Two timers timed three complete rolling periods:

$$t1 = \underline{32.89 \text{ sec}}$$

$$t2 = \underline{32.79 \text{ sec}}$$

$$t3 = \underline{32.67 \text{ sec}}$$

$$t4 = \underline{33.08 \text{ sec}}$$

$$t5 = \underline{32.97 \text{ sec}}$$

$$t6 = \underline{32.71 \text{ sec}}$$

$$\text{Total seconds: } \underline{197.11}$$

To determine the time of one rolling period, we divide the total seconds by 24:

$$\frac{197.11 \text{ seconds}}{24} = \underline{8.21 \text{ seconds}}, \text{ the time of one rolling period}$$

Now we can calculate the formula for the metacentric height, or GM:

$$GM = \frac{.4 \times .4 \times 21.92 \times 21.92}{8.21 \times 8.21} = \frac{76.88}{67.4} = 1.14 \text{ feet}$$

The metacentric height of Vessel 1 is 1.14 feet.

Vessel 2. Two timers timed three complete rolling periods:

$$t1 = \underline{23.27 \text{ sec}}$$

$$t2 = \underline{23.09 \text{ sec}}$$

$$t3 = \underline{23.37 \text{ sec}}$$

$$t4 = \underline{23.85 \text{ sec}}$$

$$t5 = \underline{23.01 \text{ sec}}$$

$$t6 = \underline{23.02 \text{ sec}}$$

$$\text{Total seconds: } \underline{139.61}$$

To determine the time of one rolling period, we divide the total seconds by 24:

$$\frac{139.61 \text{ seconds}}{24} = \underline{5.82 \text{ seconds}}, \text{ the time of one rolling period}$$

To calculate the metacentric height, or GM, of Vessel 2:

$$GM = \frac{.4 \times .4 \times 24.67 \times 24.67}{5.82 \times 5.82} = \frac{97.38}{33.87} = 2.88 \text{ feet}$$

The metacentric height of vessel 2 is 2.88 feet.

### Your vessel

Now enter the figures you derived for your vessel into the equation:

$$GM = \frac{(.4 \times .4 \times \quad \times \quad)}{(\quad \times \quad)}$$

$$GM = \quad \text{feet}$$

What does it mean?

What does the figure you derived for GM, or metacentric height, mean? If you complied with the loading and environmental conditions required for the rolling period test, and if the test gives you a metacentric height greater than 1.3 feet, your vessel appears to be stable.

Remember, however, that any changes to your loading conditions, such as adding weight or gear, will alter the metacentric height and affect the stability of your vessel.

If your calculations indicated a metacentric height less than 1.3 feet, your boat appears to be unstable and you should attempt to determine why.

Here are some things to look for:

1. Several tanks have excessive free surface. They're not completely full or completely empty--either way, they're affecting the results of the test.
2. There's a big variance from your vessel's standard loading condition.
3. You conducted the test under marginal wind, current, and wave conditions.
4. The vessel couldn't roll freely during the entire test.

If you can't find an explanation, consult a naval architect or other professional for advice.

If you have previously determined the metacentric height of your vessel but have modified the boat since, compare the old metacentric height with the one you determined with this rolling-period test.

If the rolling period test shows that the metacentric height has decreased, the stability of your vessel may also have decreased.

If the metacentric height is higher than the old value, the vessel is probably more stable than before (figure 8).

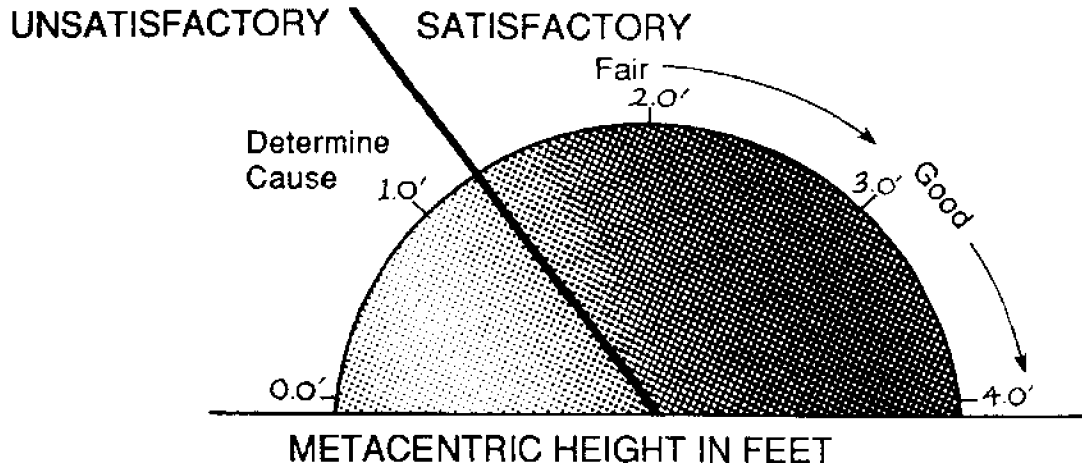

Figure 8

Now that you have estimated your vessel's stability, keep these other major considerations in mind:

1. Deeper loads and less freeboard tend to decrease stability.
2. Adding weight high on the boat decreases stability.
3. The more tanks for fluid to slosh around, the greater the instability.
4. Trim by the stern often means less stability.
5. Icing conditions reduce stability.
6. Water on deck reduces stability.

Finally, always remember that even though your boat may be stable, it may not be seaworthy.

## STABILITY DATA RECORD

Vessel \_\_\_\_\_ Date tested \_\_\_\_\_

Purpose of test \_\_\_\_\_

Vessel length \_\_\_\_\_

Beam \_\_\_\_\_

Freeboard \_\_\_\_\_

Temporary mark (beam/8) height above water line \_\_\_\_\_

Vessel load condition \_\_\_\_\_

Weather \_\_\_\_\_

Time of average roll period (T) \_\_\_\_\_

Estimated metacentric height (GM) \_\_\_\_\_

## STABILITY DATA RECORD

Vessel \_\_\_\_\_ Date tested \_\_\_\_\_

Purpose of test \_\_\_\_\_

Vessel length \_\_\_\_\_

Beam \_\_\_\_\_

Freeboard \_\_\_\_\_

Temporary mark (beam/8) height above water line \_\_\_\_\_

Vessel load condition \_\_\_\_\_

Weather \_\_\_\_\_

Time of average roll period (T) \_\_\_\_\_

Estimated metacentric height (GM) \_\_\_\_\_



---

The Oregon State University Extension Service provides education and information based on timely research to help Oregonians solve problems and develop skills related to youth, family, community, farm, forest, energy, and marine resources.

The Extension/Sea Grant Program provides education, training, and technical assistance to people with ocean-related needs and interests. Major efforts are concentrated in the areas of fisheries and wildlife, marine engineering, food science and technology, economics, business, resource management, education, and recreation.

---

Extension Service, Oregon State University, Corvallis, O. E. Smith, director. This publication was produced and distributed in furtherance of the Acts of Congress of May 8 and June 30, 1914. Extension work is a cooperative program of Oregon State University, the U.S. Department of Agriculture, and Oregon counties.

The Oregon State University Extension/Sea Grant Program is supported in part by the National Oceanic and Atmospheric Administration, U.S. Department of Commerce.

Oregon State University Extension Service offers educational programs, activities, and materials—*without regard to race, color, national origin, sex, or disability*—as required by Title VI of the Civil Rights Act of 1964, Title IX of the Education Amendments of 1972, and Section 504 of the Rehabilitation Act of 1973. Oregon State University Extension Service is an Equal Opportunity Employer.

---

RECEIVED  
NATIONAL SEA GRANT DEPOSITORY  
DATE: AUG 12 1986

NATIONAL SEA GRANT DEPOSITORY  
PELL LIBRARY BUILDING  
URI, NARRAGANSETT BAY CAMPUS  
NARRAGANSETT, RI 02882