



# **Gateway to the Pacific: the Columbia River**

**Teacher's Resource Book**

**Grades 5-7**

**CIRCULATING COPY**  
**Sea Grant Depository**

# **Gateway to the Pacific: the Columbia River**

**Teacher's Resource Book**

**Grades 5-7**



**Oregon State University**  
**Sea Grant College Program**  
**AdS 402**  
**Corvallis, Oregon 97331**  
**ORESU-E-86-001**

**NATIONAL SEA GRANT DEPOSITORY**  
**PELL LIBRARY BUILDING**  
**URI, NARRAGANSETT BAY CAMPUS**  
**NARRAGANSETT, RI 02882**

© 1986 by Oregon State University. All rights reserved.

## Acknowledgments

Writers: Vicki Osis  
Marsha Frost  
Jan Komar  
Peter Bellamy  
Peter Wilson  
Dan Guthrie

Editor: Sandy Ridlington

Illustrator: Matthew Schumaker

Additional  
illustrations  
by: Kip Anastasiou  
Jan Kerns  
Amy Charron  
Phil Schuyler

This book was conceived and organized by the Pacific Circle Consortium;

supported by the Northwest Association of Marine Educators, the Environmental Education Association of Oregon, and the Northwest Educational Laboratories;

and published through the cooperation of the Extension/Sea Grant Program at Oregon State University.

Special thanks for permission to use the following illustrations: P. 130, seal and sea lion, illustrated by Phil Schuyler in Anita E. Daugherty, Marine Mammals of California, 3rd ed. (1979; La Jolla: California Sea Grant, 1985); pp. 42 and 46. Pp. 123 and 124, great blue heron, and p. 128, glaucus-winged gull, illustrated by Kip Anastasiou in The Estuary Book (Vancouver, B.C.: Western Education Development Group, 1981), p. 32. Pp. 125; Brandt's cormorant, 126, white-winged scoter, 127; brant, and 127, common loon, illustrated by Kip Anastasiou in The Beach Book (Vancouver, B.C.: Western Education development Group, 1978), pp. 30 and 31.

---



---

Contents

---



---

Introduction - - - - -	iv
<b>PART ONE: LESSONS . . . . .</b>	<b>1</b>
Entering the Harbor - - - - -	2
1. Introduction to the Columbia River and the Pacific. --	3
2. History of the Columbia River - - - - -	7
3. Ships and Shipping on the Columbia River - - - - -	9
4. Mapping the Columbia - - - - -	17
5. Latitude and Longitude - - - - -	21
Use of the Harbor - - - - -	24
6. Ships in the Harbor - - - - -	25
7. Cargo Transfer . . . . .	36
8. Ship's Communication . . . . .	43
9. Ships and How They Float - - - - -	46
10. Home Goods Survey - - - - -	50
11. Seaman's Diary - - - - -	52
12. Harbor Careers - - - - -	56
The Harbor Environment - - - - -	62
13. Habitats of the Columbia Estuary - - - - -	63
14. Natural Habitats and Human Uses of Harbors - - - - -	70
15. English Sole Life Cycle . . . . .	78
You and Your Harbor - - - - -	85
16. Field Trip to the Harbor - - - - -	86
17. Simulation Game "Cargo" - - - - -	87
<b>PART TWO: READINGS - - - - -</b>	<b>97</b>
The Captain Comes into Port . . . . .	98
Bringing Ships into Port: the Life of a Bar Pilot . . . . .	104
A Day in the Life of a Tubgoat Captain - - - - -	110
Cradle of Life: the Columbia River Estuary - - - - -	115
The Fish and Wildlife of the Columbia River - - - - -	123
A Little Coastal Town - - - - -	133
 <b>PART THREE: VOCABULARY . . . . .</b>	 <b>142</b>

---

## Introduction

---

---

This curriculum has been developed by the Oregon Sea Grant program through participation in the Pacific Circle Consortium's Ocean Project. Each member nation of the consortium has produced a home study unit, similar to this Columbia River unit, on a harbor in his or her country. Participants in the consortium are Australia, whose harbor study is Gladstone; Canada, with its port of Vancouver; Japan, who selected Hiroshima; and New Zealand, who developed materials about Wellington. The University of Hawaii coordinated the project and developed a unit on Honolulu.

The bays and harbor study comprises the following components:

1. Home units
2. International Teachers Handbook
3. Exchange unit--Hiroshima, Japan

The International Teachers Handbook, which is in preparation, describes all the home units. For a copy, contact Extension/Sea Grant, Hatfield Marine Science Center, Newport, Oregon 97365.

Briefly, the project was conceived as a study of the home harbor, followed by a study of one other harbor. Special Japanese materials, a week-long unit on Hiroshima, have been designed to follow the home unit study. Home units from other countries are available if a study of any of the other harbors is desired. Information about any of the materials is available from the Extension/Sea Grant marine education specialist at the Hatfield Marine Science Center, Newport, Oregon 97365.

The goal of the project is to provide information to students about the interdependence of Pacific nations through trade. Through the use of these materials, students will gain an understanding of our Pacific neighbors and bring about an awareness of the dependence of nations on each other for materials and products.

# **Part One: Lessons**

## **Entering the Harbor**

---

## 1. Introduction to the Columbia River and the Pacific

---

---

### Intent:

The students will locate the Columbia River in relation to the Northwest region of the U.S. and to the Pacific.

### Main Ideas:

1. The Columbia River is located in the northeast Pacific.
2. The Columbia River is in the northwestern region of the United States.
3. The mouth of the river, called the bar, is the most treacherous portion of the river to navigate.
4. The Columbia River is in a good location for trade with other Pacific countries.

### Resources:

1. Blank map of the world
2. Blank map of the U.S.
3. "Approaching the Harbor" slide set
4. Short story, "The Captain Comes into Port" (see Part Two)
5. Vocabulary list, "The Captain Comes into Port" (see Part Three)

### Activities:

1. Mapping
  - Using the blank map of the world and an atlas, locate and record the Pacific Ocean, the U.S., the Columbia River, and Portland, Oregon.
  - Discuss with students and list on the chalk board the Pacific countries that may be trading partners with ports on the Columbia. Be sure to list Japan, Korea, China, the Philippines, and Australia.
  - Discuss which other harbors on the West Coast may also be involved with trade in the Pacific Basin. Suggest Seattle, Los Angeles, San Francisco, and Vancouver, Canada.



- With a string and a world map with a scale, measure the distance between other West Coast ports and Pacific Basin harbors. Which of the West Coast harbors is closest to Japan? Which is the closest to Australia, Korea, and so on?
  - What factors other than distance might determine the volume of trade between harbors? For example, the aluminum plants along the Columbia create a demand for alumina from Australia.
2. Slide presentation: "Approaching the Harbor"
- Show the slides to the class and have them write down the first few words that come to mind. Encourage the students to ask questions about the slide set and develop a composite list of words on a board or wall chart for display.
3. Reading the story "The Captain Comes into Port"
- Go over the vocabulary list with students and discuss each term.
  - Reproduce copies of the story "The Captain Comes into Port." Have each student read the story.
  - Discuss the story using the following questions.
    - a. What type of ship was coming into harbor and where had it come from?
    - b. How long did the voyage take?
    - c. What is the entrance to the river like?
    - d. How does the ship enter the river?

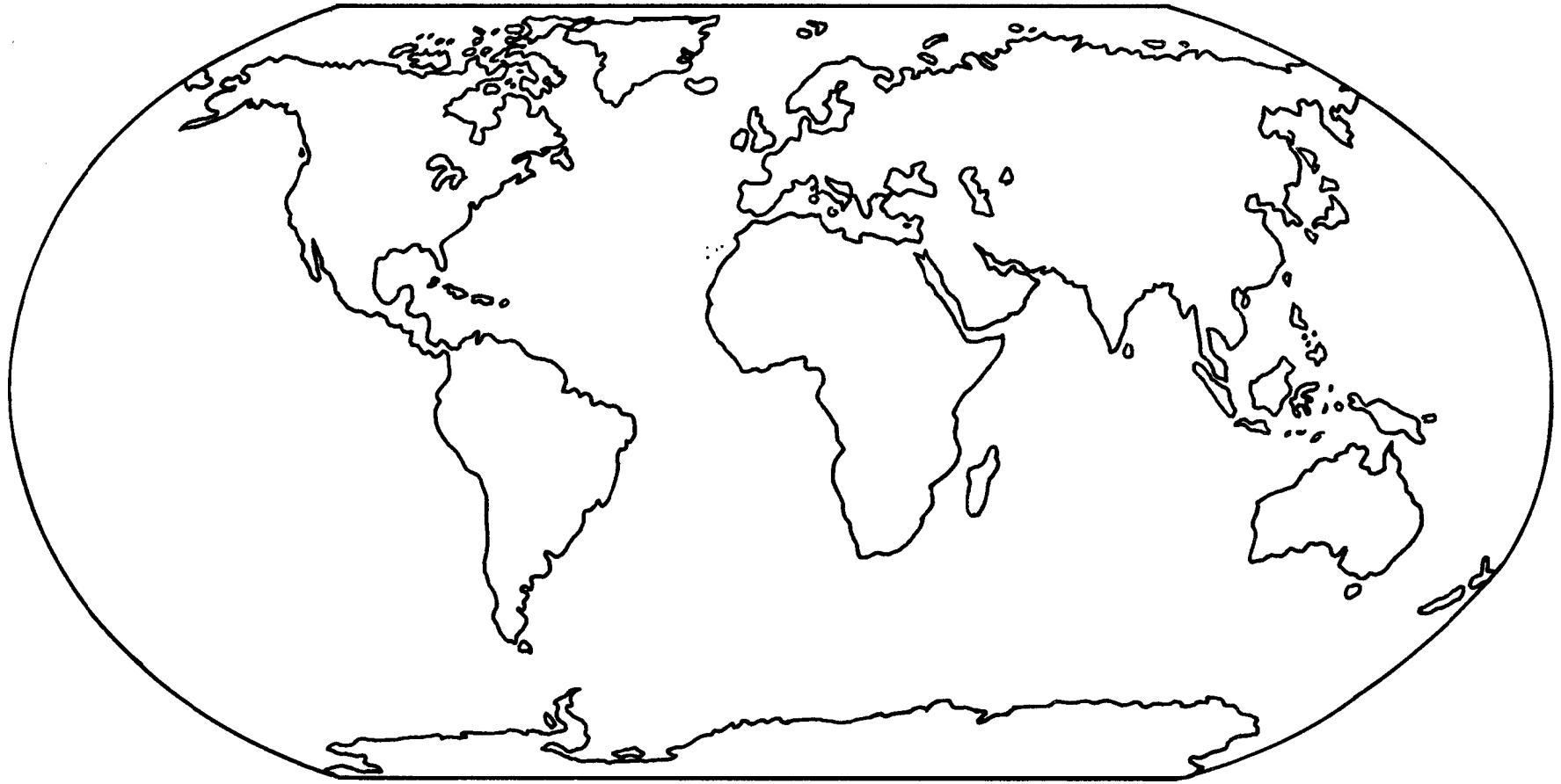

BLANK MAP OF WORLD

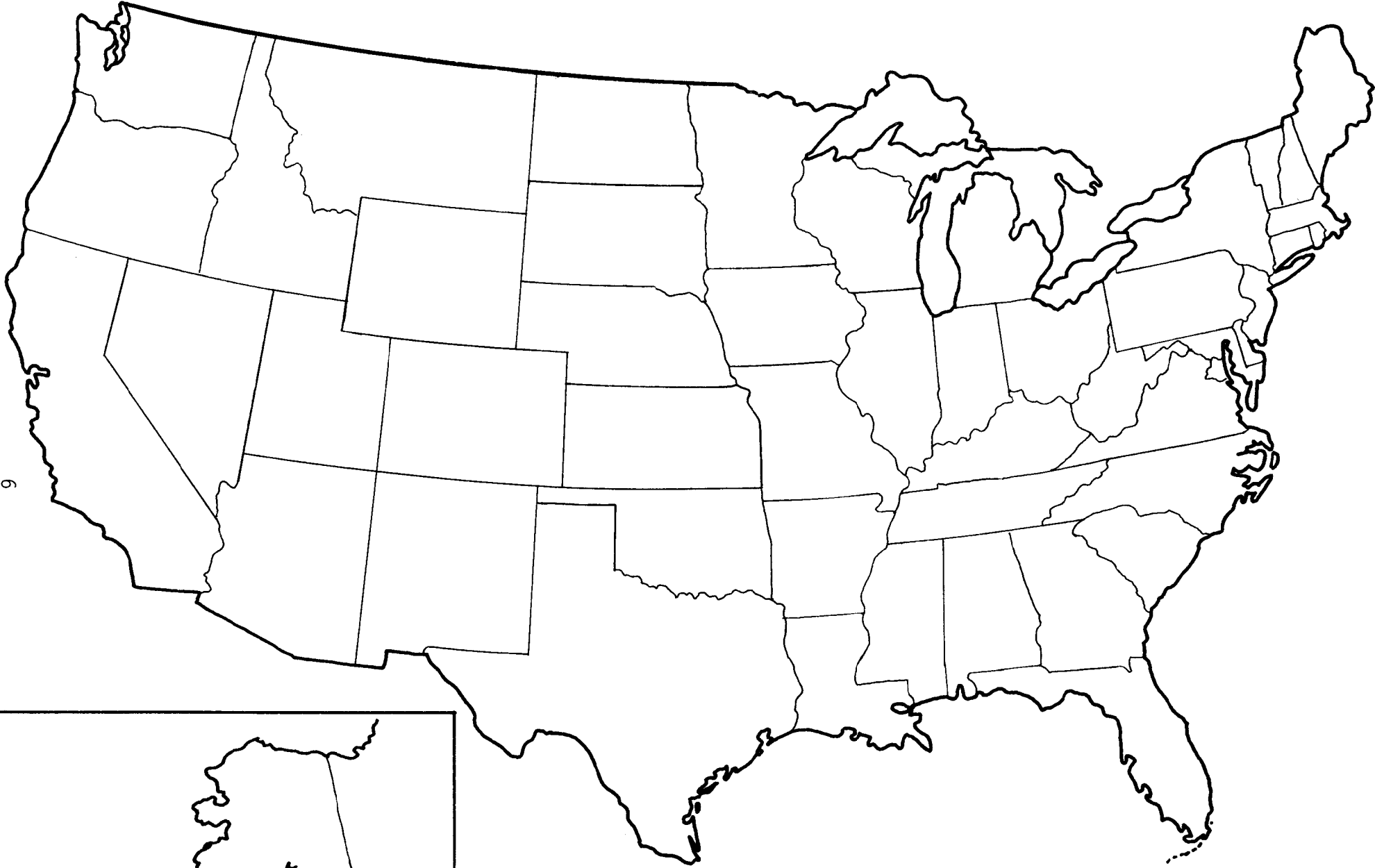

9

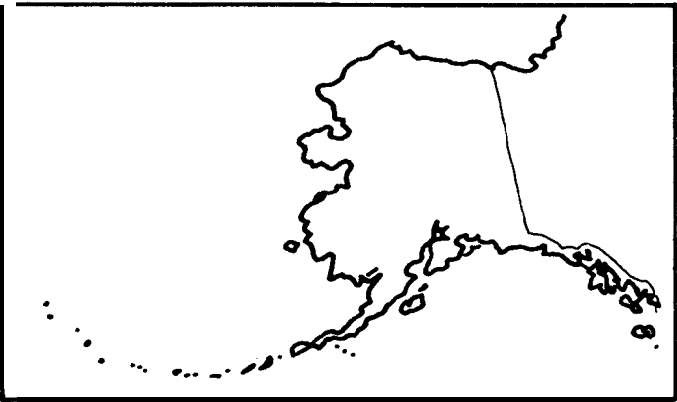

BLANK MAP OF THE UNITED STATES

---

## 2. History of the Columbia River

---

---

### Intent:

Students will become knowledgeable about the early history of the Columbia River estuary and demonstrate their knowledge by dramatizing a chapter of Columbia River history.

### Main Ideas:

1. The Astoria area is important in the history of the United States.
2. The Lewis and Clark expedition overwintered in the Astoria area and built Fort Clatsop.

### Resources:

1. Resource books about the Lewis and Clark expedition
2. 3- by 5-inch cards

### Activities:

#### Lewis and Clark expedition

- Divide the class into small groups of six to eight students.
- Write the following on a set of 3- by 5-inch cards. Pacific NW Indian customs, Winter at Fort Clatsop, Building Fort Clatsop, The help of Sacajawea, Dangers of exploring the frontier, and Celebrating Christmas at Fort Clatsop.
- Have each group choose one of the 3- by 5-inch cards to obtain their research topic.
- Give each group the opportunity to research its topic.
- Ask students to work together within their groups to devise a short skit or dramatic scene summarizing the information they learned through their research.
- Have each group act out their skit or scene for the class.
- Built a model of Fort Clatsop, using pretzels and milk cartons.
- Make a diorama picturing a scene from the Lewis and Clark expedition.

References: Lewis and Clark

Andrist, Ralph. To the Pacific with Lewis and Clark. New York: Harper and Row, 1976.

Clark, Ella, and Margot Edmonds. Sacajawea of the Lewis and Clark Expedition. Berkeley: University of California Press, 1979

Salisbury, Albert and Jane. Two @p tai West: A: Historical Tour of the Lewis and Clark Trail. ~~New York: Bramhall,~~

---

### 3. Ships and Shipping on the Columbia River

---

---

Intent:

Students will gain an understanding of the development of the river as a major transportation system in the Northwest.

Main Ideas:

1. Different types of vessels have been used on the Columbia over time.
2. Changes in technology have greatly changed the use of the Columbia River as a major transportation system.
3. Early settlers depended on the river as a transportation system.
4. The river is now a major route for the transportation of goods and products.

Resources:

1. Reading: "Ships and Shipping on the Columbia River"
2. Drawings of various types of ships which have used the Columbia River
3. Boat pattern
4. Time scale: Events on the Columbia

Activities:

1. Discuss with students the types of vessels used on the Columbia over time.
2. Develop a display showing the types of vessels and a time scale showing when each type of vessel was being used on the Columbia River.
3. Using the pattern for a paddle wheeler, have the students build a model stern-wheeler. Teachers may wish to have the middle school or high school shop class prepare the wooden pieces from the pattern. Students may paint or decorate their boats once they are completed.

Source: Columbia Maritime Museum. "When the River was the Road" teaching kit.

## Ships and Shipping on the Columbia River

From the early voyages of exploration and discovery to maritime trade by sail and diesel engine, the Columbia River and its ships have had a profound influence on the lives of the people of the Northwest.

In 1792 Captain Robert Grey of Boston was one of the many Europeans and Americans who came to the west coast for the rich fur trade. Sea otters at that time were abundant along the west coast and could be sold for a handsome profit in China and the Far East. Grey's 83-foot-long armed merchant ship, the Columbia Rediviva, took its place in history as Grey entered the mouth of the Columbia and named the river after his ship. When Grey entered the river he found Native Americans on the river in their dugout canoes of cedar.

In 1802-03 the Lewis and Clark expedition came across the west and down the Columbia to explore and open the land west of the Mississippi River. They built a fort, Fort Clatsop, along the shores of the Columbia to spend the winter in before their return to Missouri. Their main means of travel on that expedition was by canoe. The natives they found living in the area also used canoes on the river and even ventured out into the ocean in them.

In 1811 John Jacob Astor organized the first permanent American settlement west of the Rocky Mountains and named it Astoria. This new settlement received goods and supplies by sailing ship. The furs which initially attracted the settlers there were sold and transported out of Astoria on sailing ships.

As other settlements began to be established in the Northwest, the settlers either lived near the water or risked total isolation. There were few roads, and most travel took place on the waterways. In those days sailing ships were the major means of transporting goods and of travel.

In the mid 1800s steam-powered vessels began to appear. Steam-powered paddle wheelers such as the side-wheeler Beaver began to be used. Hundreds of such boats were constructed during the next 75 years and opened up the river to extensive travel. River steamers such as the TJ Potter, the Bailey Gatzert, and the Georgiana became a common sight on the river. When people had to move cargo or when they simply wanted to go somewhere, they went down to the river and hailed the next steamboat. River steamers hauled everything from cattle and produce to the local baseball team.

Around 1930 the steam-powered boat was replaced by the more efficient diesel-powered vessel. The era of modern shipping on the Columbia had begun.

In the 1930s the first of the dams was constructed on the river. These dams slowed the flow of the river and changed it from a free-flowing river into a series of lakes. As the dams were built, locks were constructed to enable ships to move up and down the river. This opened up the interior regions to shipping, and agricultural products could be brought down the river and shipped to markets in the Pacific Basin. Today tugs and barges of grain produced in Washington, Oregon, and Idaho travel down the river to Portland and ports downriver to be loaded on grain ships to be shipped to markets in the Orient and beyond. The Columbia-Snake system has become one of the major transportation routes in the world.

Also during the 1930s the coast highway was constructed. However, no bridge was built on the Columbia. Transportation across the river took place by ferry. In 1966 the Astoria bridge was built and cars could drive across the Columbia River.





Dugout canoe

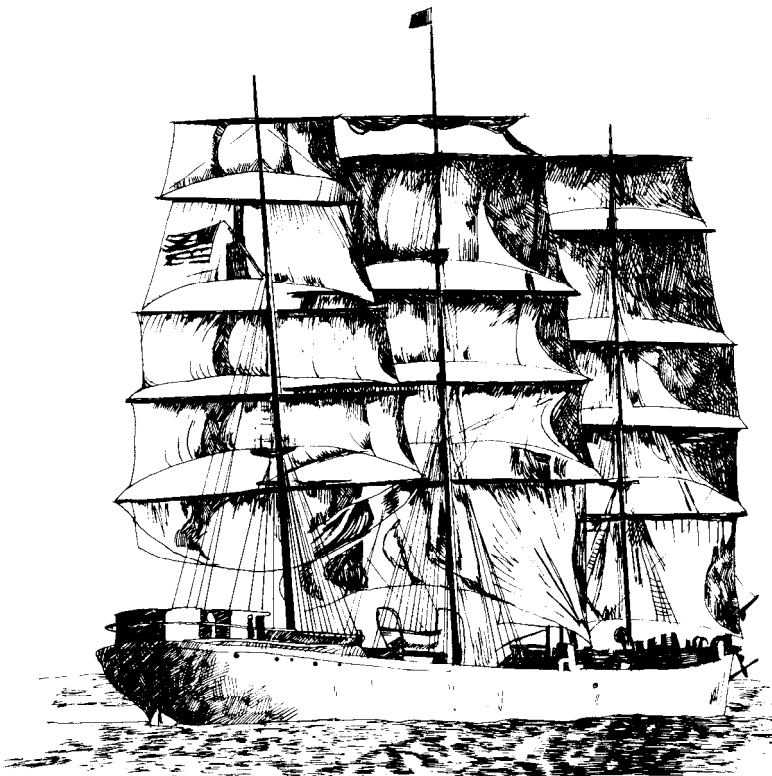

Sailing ship

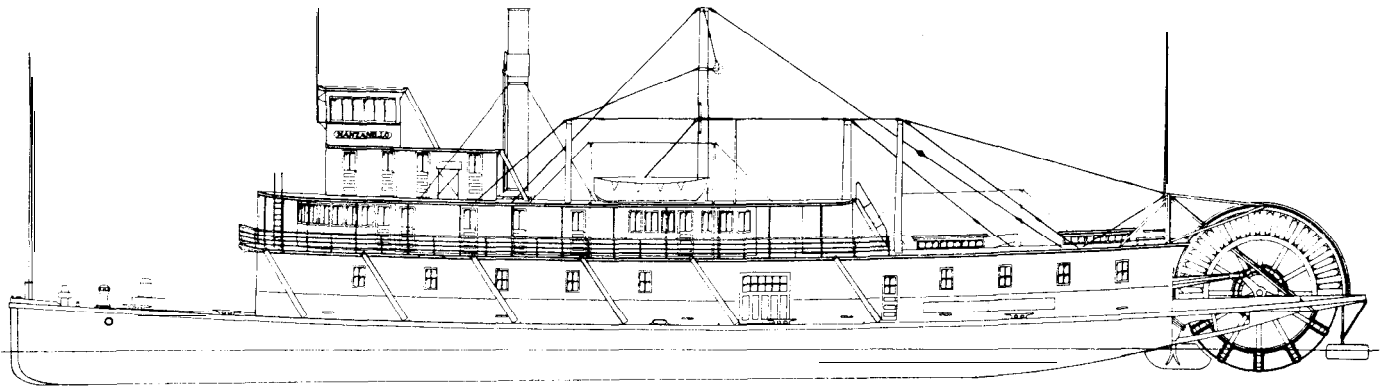

Stern-wheel er

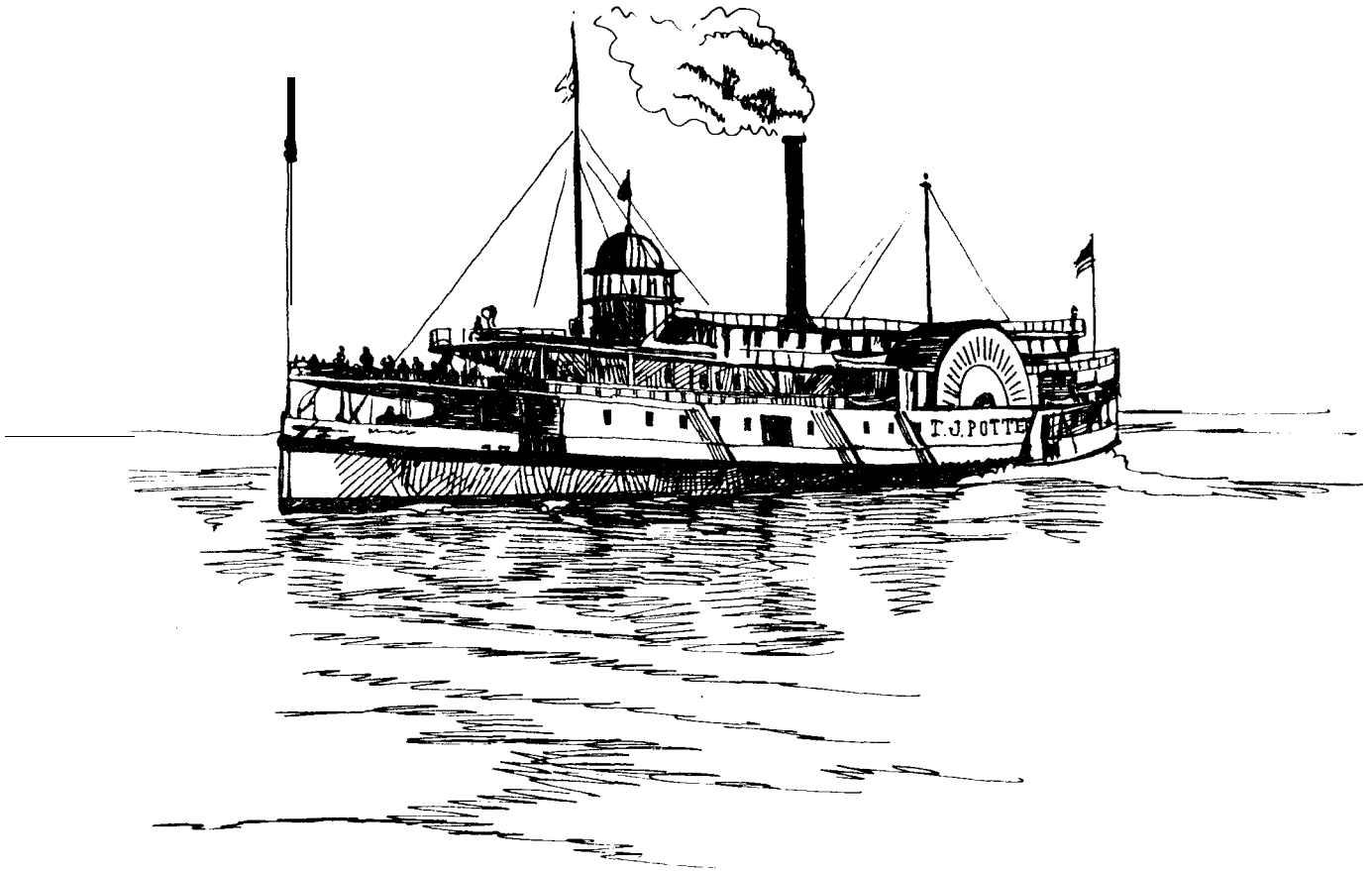

Si de-wheel er

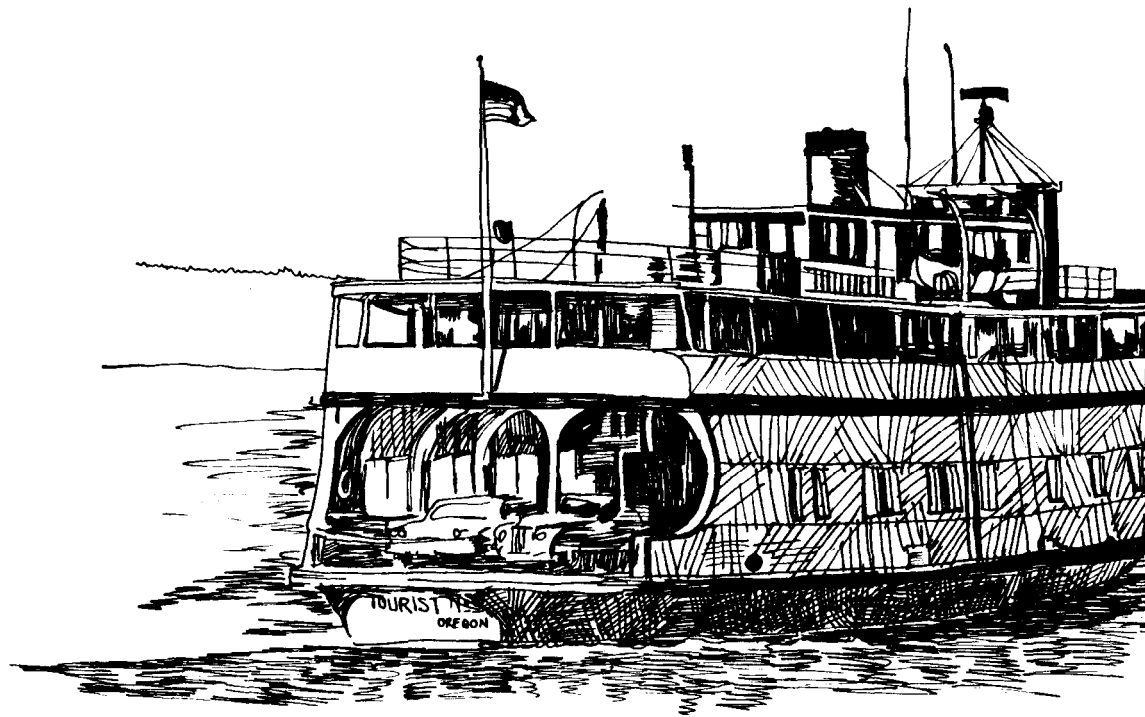

Columbia River ferry

Notch for Rubber Band

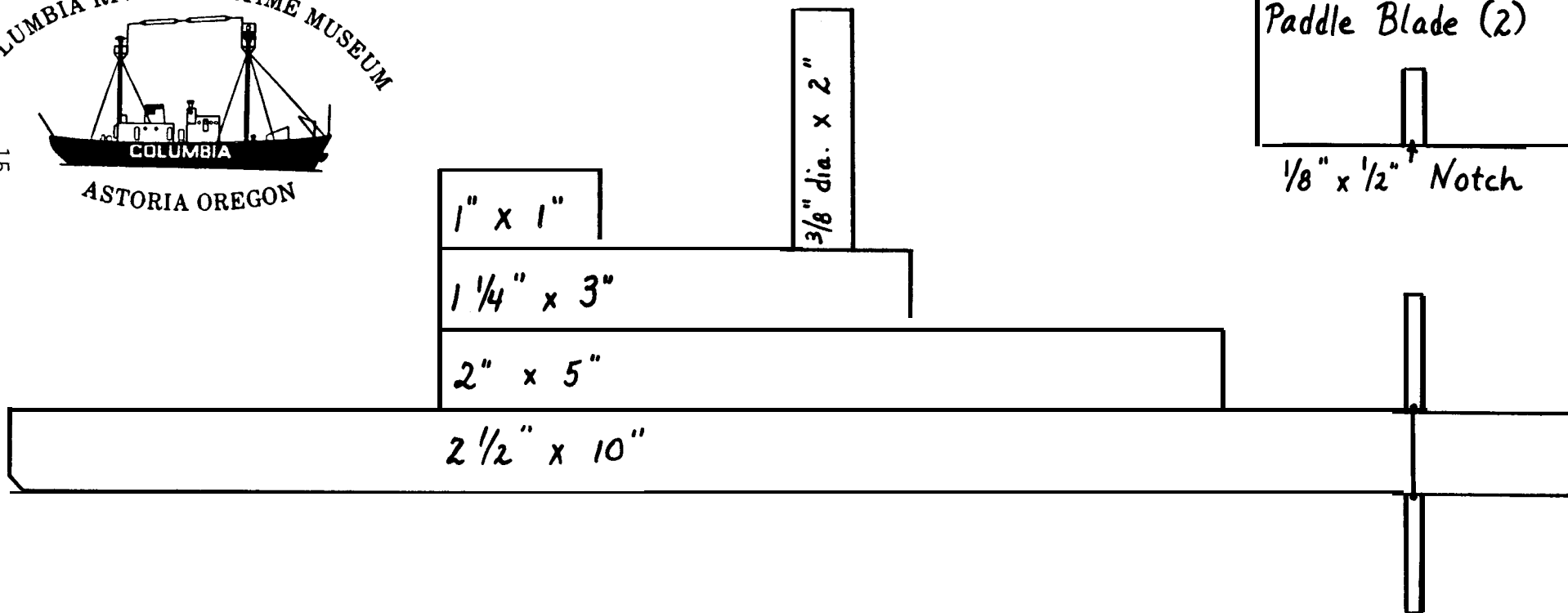
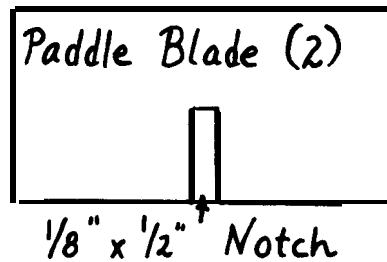
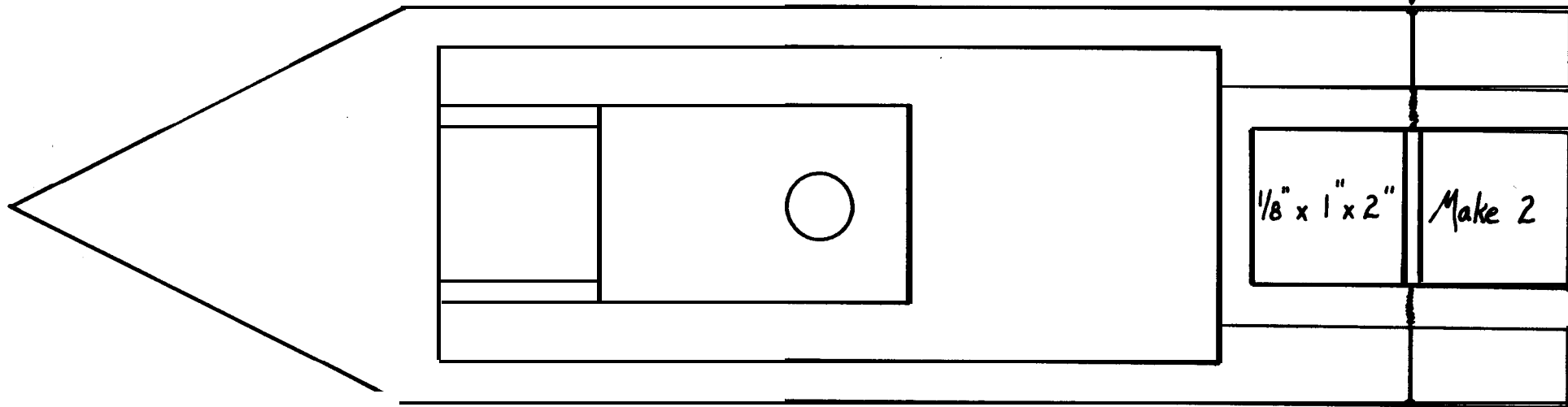

SHIPS ON THE COLUMBIA

EVENTS ON THE COLUMBIA

SHIPS ON THE COLUMBIA	EVENTS ON THE COLUMBIA
	1513 Balboa discovers the Pacific Ocean.
	1578 Sir Francis Drake is the first English-speaking person to sight the northwest coast.
CANOES	1792 Captain Robert Gray discovers the Columbia River.
	1805-1806 The Lewis and Clark expedition winters at Fort Clatsop.
SAIL-POWERED VESSELS	1811 Astoria is founded.
	1836 The steam-powered paddle wheeler <u>Beaver</u> (built in England) arrives on the Columbia.
STEAM-POWERED VESSELS	1850 The side-wheeler <u>Astoria</u> is the first steam-powered paddle wheeler to be built on the Columbia.
	1910 Gasoline-powered gill net boats replace sail-powered boats.
	1930 Diesel-powered ships, including ocean-going vessels, come onto the Columbia.
	1933 The first dam (Rock Island) is built on the Columbia.
DIESEL-POWERED VESSELS	1980 Super tankers come into Columbia for dry docking in Portland.
	1981 The last commercial, steam-powered, stern-wheeler tugboat on the Columbia is retired.
	1986

---

## 4. Mapping the Columbia

---

### Intent:

Through a series of mapping activities and a short story, the students will establish the location of the city of Astoria and become familiar with the features of the mouth of the Columbia.

### Main Ideas:

1. The Columbia River is the second largest river in North America.
2. The Columbia River is one of the major trading centers on the West Coast.
3. Astoria is the first port of call inside the Columbia River and provides support facilities for ships entering and leaving the harbor.

### Resources:

1. Map of the Columbia River Basin
2. Map of the mouth of the Columbia River
3. Short story, "Bringing Ships to Port: the Life of a Bar Pilot" (see Part Two).
4. Vocabulary list for "Bar Pilot" story (see Part Three).

### Activities:

1. Introductory mapping
  - Using the blank map of the Columbia River basin and an atlas, locate and record the Pacific Ocean and the province of Canada and the states of the U.S. that are drained by the Columbia River.
  - Locate and record the Columbia River and its tributaries.
  - Shade in and name some of the major mountain ranges of the Columbia River Basin.
  - Use a piece of string to estimate the length of the Columbia and Snake rivers.
  - Build a model of the Columbia River Basin using salt dough. Indicate on the model mountain ranges in the basin, major ports on the river such as Astoria;

Longview, Washington; St. Helens; and Portland. Ocean ships go up the river as far as Portland while river barge traffic continues up the river as far as Lewiston, Idaho. Indicate the two types of shipping on the model.

2. Reading the story "Bringing Ships to Port: the Life of a Bar Pilot"
  - Read the vocabulary list to the students and discuss each term.
  - Reproduce copies of the story for the students to read. Discuss the story using the following questions:
    - a. What kinds of ships enter the Columbia River?
    - b. What kinds of cargoes do they carry?
    - c. Describe a bar pilot's job.

# COLUMBIA RIVER BASIN

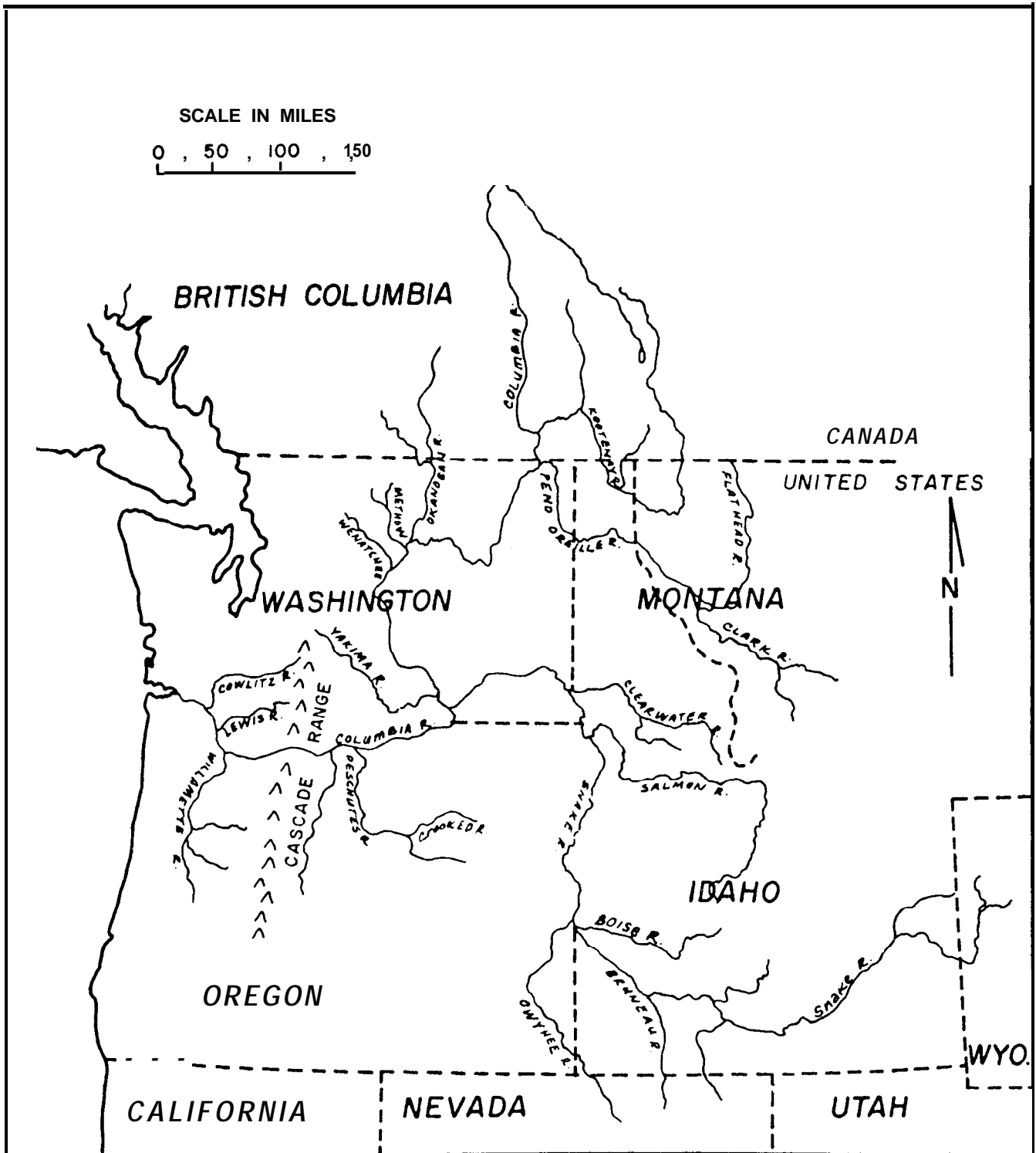



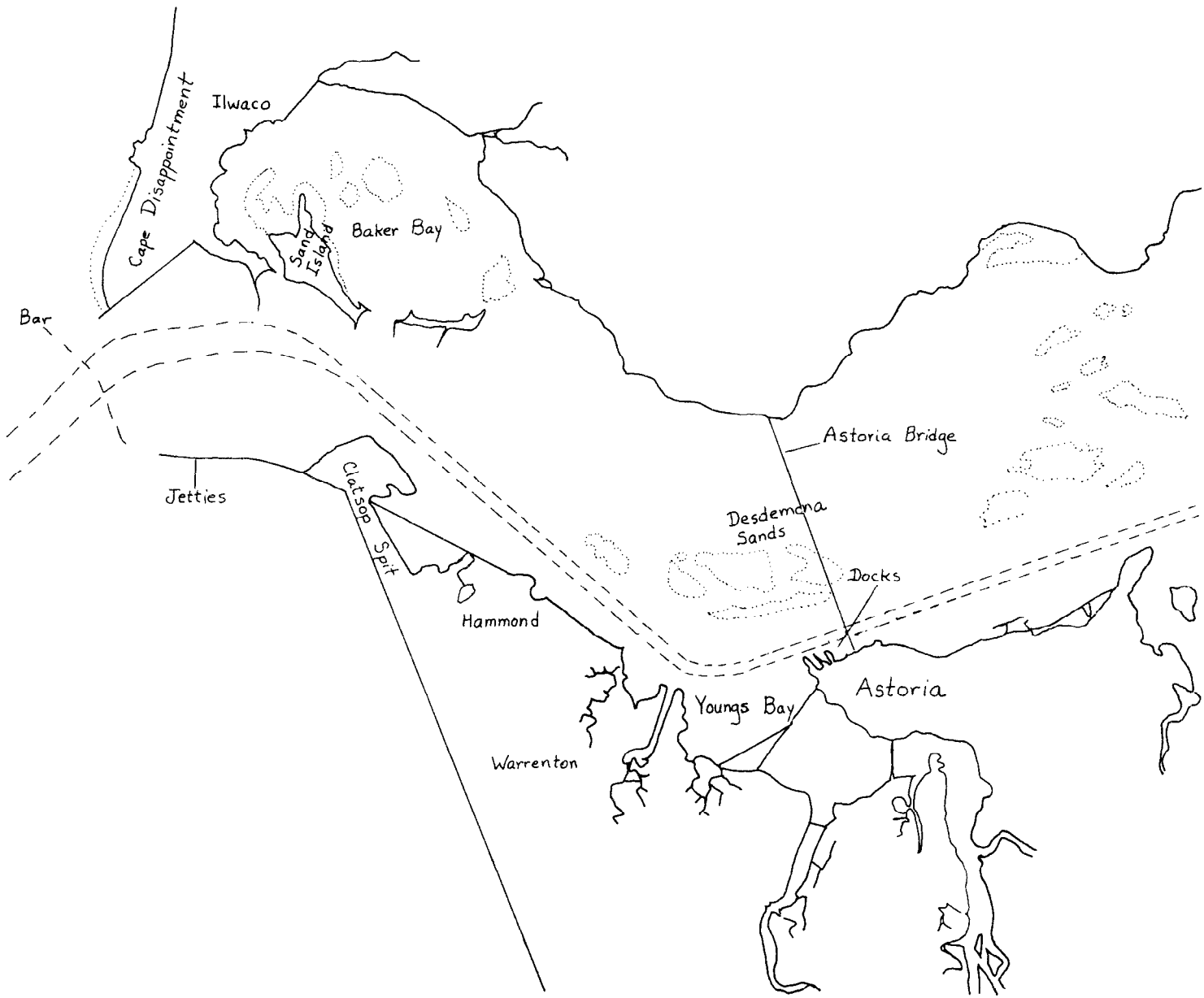

THE MOUTH OF THE COLUMBIA RIVER

---

## 5. Latitude and Longitude

---

---

Intent:

Students will learn to use latitude and longitude to locate any point on Earth.

Main Ideas:

1. Latitude lines run east and west, while longitude lines run north and south.
2. Latitude readings are given north or south of the Equator, while longitude readings are given east and west of the Greenwich meridian.

Resource:

Map of the Pacific Basin

Activities:

1. Duplicate and distribute to each student the Pacific Basin map.
2. Discuss with students the following facts:
  - Latitude lines run east and west, while longitude lines run north and south.
  - Latitude readings are given north or south of the Equator, which is 0 degrees latitude.
  - Longitude readings are given east or west of the Greenwich meridian, which is 0 degrees longitude.
  - The International Date Line is 180 degrees longitude.
  - The unit for measuring the latitude and longitude is the degree ( $^{\circ}$ ). A degree is further divided into minutes ( $'$ ) and seconds ( $''$ ).
  - Distance at sea is measured in nautical miles.  
6,076 feet = 1 nautical mile.  
1' of latitude = 1 nautical mile.  
 $60'$  =  $1^{\circ}$  of latitude.  
 $1^{\circ}$  of latitude = 60 nautical miles.
3. Using a wall chart or globe, locate the Greenwich meridian, the International Date Line, and the Equator. Give their latitude or longitude readings.
4. Have the students locate and estimate the latitude and longitude of the following Pacific Harbors:

## Pacific Harbors

<u>Name of Harbor</u>	<u>Estimate</u>	<u>Actual</u>	<u>Comparison</u>	<u>Nautical Miles Estimate</u>
Seattle, U. S. A.				
Gladstone, Australia				
Wellington, New Zealand				
Suva, Fiji				
Honolulu, U. S. A.				
Los Angeles, U. S. A.				
Yokohama, Japan				
Hong Kong				
San Francisco, U. S. A.				
Vancouver, Canada				
Valparaiso, Chile				
Portland, U. S. A.				
Manila, Philippines				

Example: Hiroshima, Japan

	<u>Latitude</u>	<u>Longitude</u>
Student Estimate:	38°N	134°E
Actual Location:	34°N	132°E
Difference:	4°N	°

What was the difference in nautical miles between the student estimate and the actual location?

$$\text{lat. } 4^\circ \times 60 \text{ miles} = 240 \text{ nautical miles}$$

Complete the chart to find the latitude and longitude of Pacific harbors.

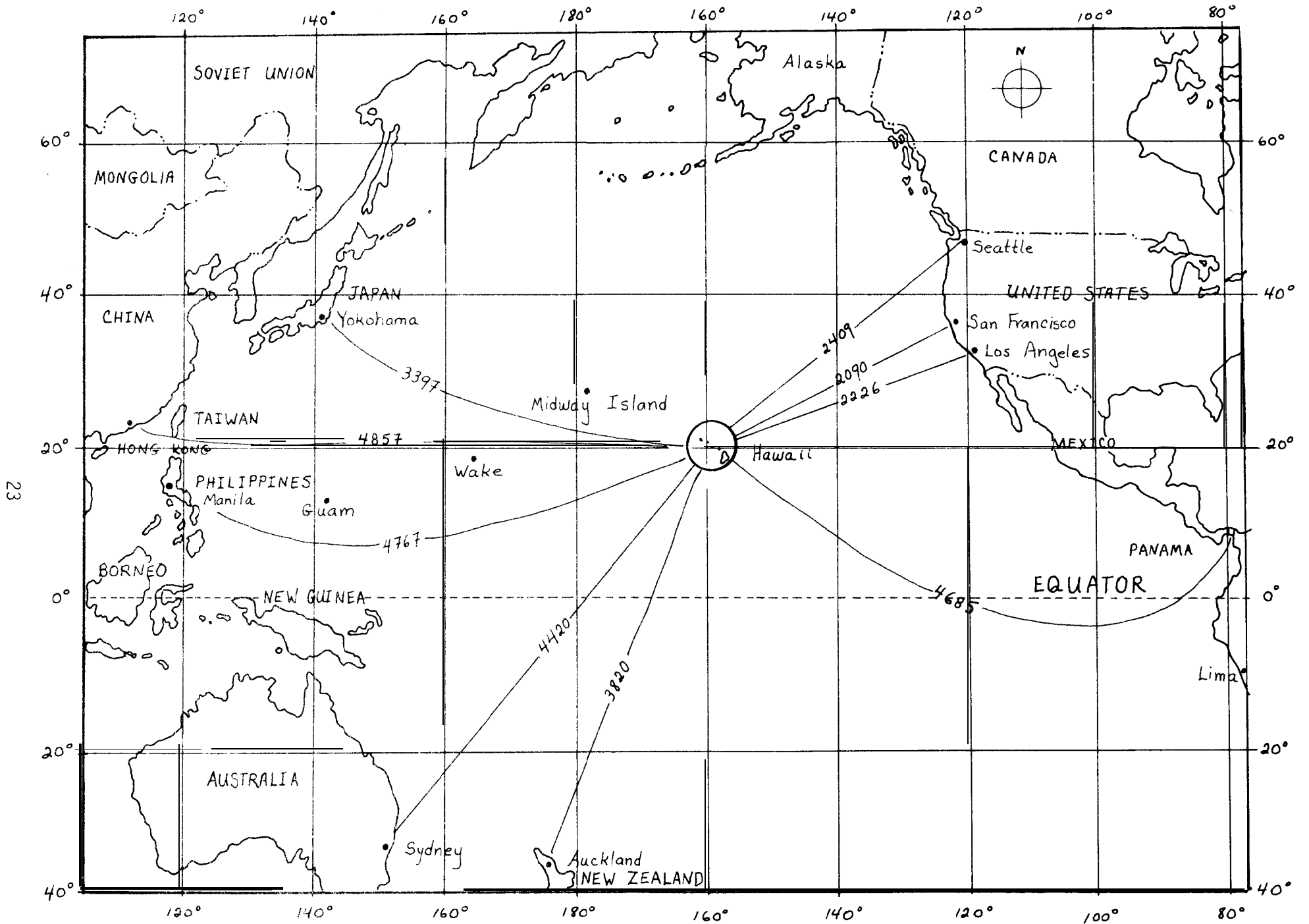

THE PACIFIC BASIN

## **Use of the Harbor**

---

## 6. Ships in the Harbor

---

---

### Intent:

Through graphing exports and imports and developing a display of different types of ships, students will learn which countries are our most important trading partners and the types of ships which transport trade commodities.

### Main Ideas:

1. Much of the Columbia River trade is with countries in the Pacific Basin.
2. Farm and forest products are the main export items from the Columbia, while manufactured goods and raw materials are the major import items.
3. Ships of different types are used to carry different items.

### Resources:

1. Export and import tables
2. Drawings of ship types
3. Vessels chart
4. Blank map of the world (see lesson 1, "Introduction to the Columbia River and the Pacific")
5. Short story, "A Day in the Life of a Tugboat Captain" (see Part Two)
6. Ships calendar for the Columbia River

### Activities:

1. Ship study
  - Look at the information on the ship data sheets. Complete the vessels chart.
  - Discuss how changes in technology have changed the types of vessels which have been used on the Columbia.
  - From the ships calendar, identify how many ships are U.S. owned and how many are foreign owned.
  - Most ships are foreign owned and fly a flag of convenience. This simply means that the ships are registered to a country other than the country of

- ownership. Many of the ships calling at Northwest ports are registered to Panama or Liberia but are actually owned by companies in other countries. U.S. safety regulations and high labor costs have discouraged the development of an extensive merchant marine by the U.S.
- Have the students use the information from the export and import tables to make bar graphs of export and imports into the Columbia.
- On the world map, color in countries that receive goods from the Columbia (export column). Color in a different shade the countries that send materials into the Columbia (import column).
- Have the students fill in the vessel chart.

## 2. Short story

- Read the story "A Day in the Life of a Tugboat Captain," and have the students discuss the following questions.
  - a. What are the uses for tugboats in the harbor?
  - b. What are some of the responsibilities of a tugboat captain?
  - c. Think about the first two stories and tell how the tugboat captain must work with the ship's captain and the bar pilot.

## 3. Countries we trade with

- Pick the top four countries from the export and import columns. Discuss with students who have not yet researched the subject what they know about each country. List four things on the chalk board under each country that the students suggest about each country.
- Learn the following about each of the countries and have students turn in reports with the following information:
  - a. type of government
  - b. capital
  - c. language
  - d. a typical greeting or phrase from each country

### Items Exported by Columbia River Ports

<u>Item</u>	<u>Short Tons</u>
Wheat	10,571,557
Barley	1,072,366
Logs	2,851,752
Corn	5,505,681
Soda ash	761,590

### Items Imported into the Columbia River Ports

<u>Item</u>	<u>Short Tons</u>
Metal, misc. iron and steel products	438,407
Alumina ore	412,935
Auto vans and parts	371,015
Ore, limestone	291,130
Crude salt	281,979
Petroleum products	103,605



## Trading Partners with Columbia River Ports

### Exports and Imports into the Columbia

<u>Exports</u>	<u>Exports-- Short Tons</u>	<u>Items Received from Columbia Ports*</u>
Japan	4,390,439	Wheat, corn, barley, logs
Republic of Korea	1,525,443	Wheat, metal scrap, corn, waste paper
Taiwan	982,158	Wheat, barley, corn, soda ash
Africa	628,969	Grass seed, machinery, paperboard, medicine, wheat, flour, wood pulp
Indonesia	521,163	Wheat, soda ash
Bangladesh	371,715	Wheat
Philippines	253,237	Wheat, soda ash, waste paper, malt
Iraq	153,674	Barley
Hong Kong	134,269	Wheat, paperboard, soda ash, dried peas
Sri Lanka	118,454	Wheat, barley

<u>Imports</u>	<u>Exports-- Short Tons</u>	<u>Items Received from Columbia Ports</u>
Japan	780,778	Steel products, autos and vans, tractors, machinery parts
Canada	465,167	Limestone ore, cement, gasoline, methanol
Australia	427,975	Alumina, steel products, manganese, aluminum, zinc
West Germany	72,848	Steel products, autos and vans, alcoholic beverages
Taiwan	58,938	Asphalt, hardware and tools, steel lawn furniture
Republic of Korea	52,492	Steel, athletic shoes, wire rope, photo albums, canned mushrooms
Philippines	44,384	Coconut oil, athletic shoes, canned tuna
Belgium	40,947	Tractors, agricultural machinery, wire

\*Data for Portland

## SHIPS ON THE COLUMBIA-- 1

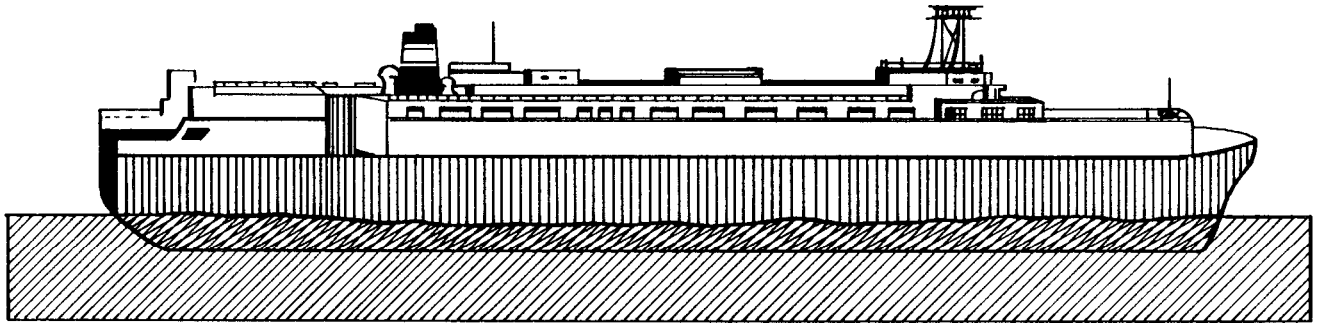

Auto Ship - Exterior

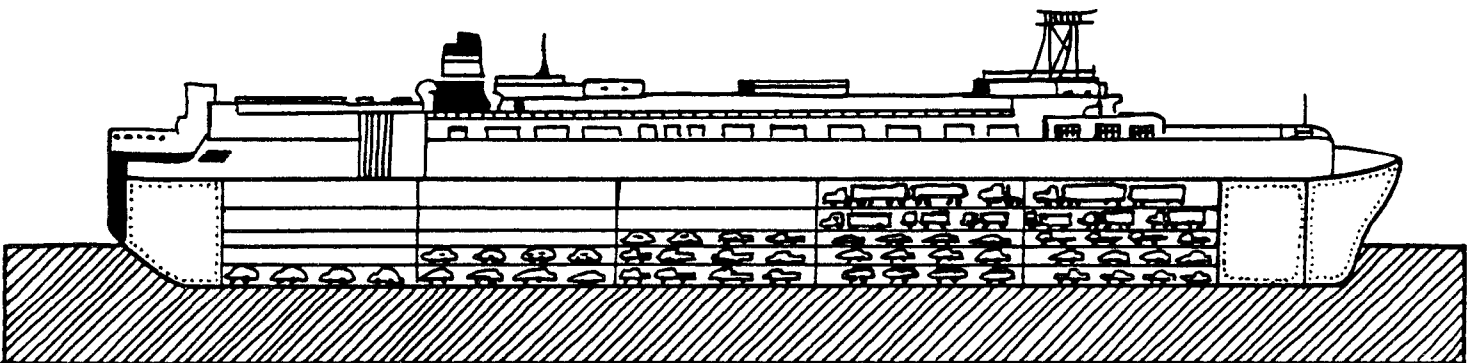

Auto Ship - Interior

### 1. AUTO SHIP

These ships are designed specifically to transport one item--cars. Cars can be driven on and off these ships by ramps which lower from the ship onto the dock. These ships usually carry no other item, so they are loaded on only one half of their trip. They load cars in Japan, unload in the U.S., and return empty for another load of cars. Occasionally Honda ships return with cattle on board in specially built cages with special dry food for the trip. These ships are 900 feet long.

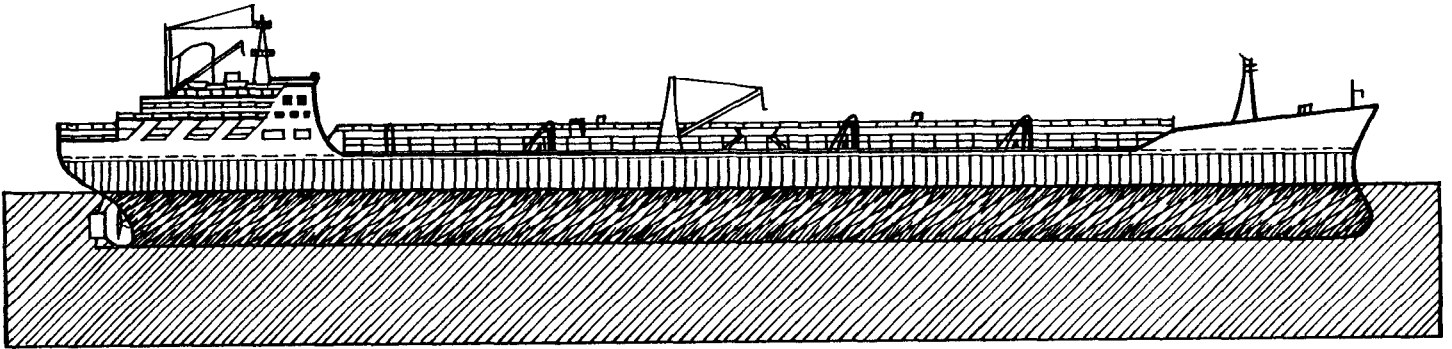

Tanker-- Exterior

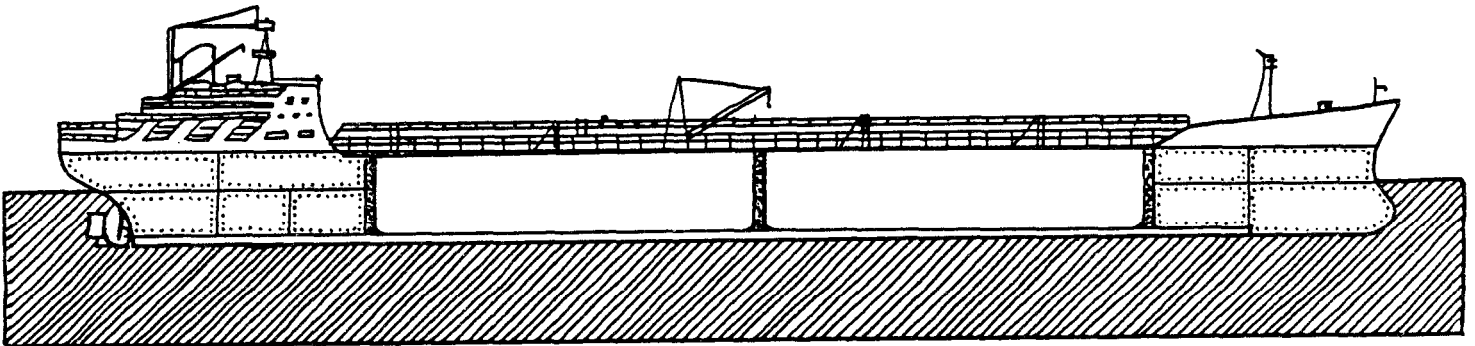

Tanker-- Interior

## 2. TANKERS

Tankers transport liquid materials. Although they can carry liquids such as vegetable oil, molasses, or tallow, the most common material transported is oil. Small tankers enter ports to load and unload while super tankers more often anchor at sea and offload near shore. Super tankers, which are 1,100 feet long, enter the Columbia River empty for repair work in the Portland shipyards.

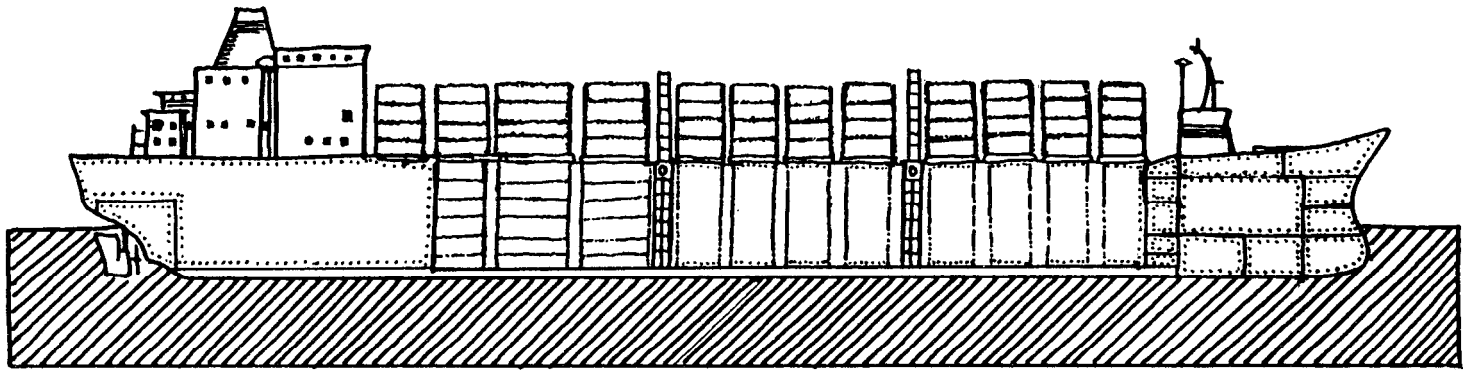

Container Ship--Interior

### 3 . CONTAINER SHIPS

Container ships, 700 to 900 feet long, carry large containers of two sizes--20 feet and 40 feet. Large dockside cranes lift the containers on and off the ships. The containers are then moved by truck or train to their final destination. Containers can be filled with any number of items, from stereos and cameras to lumber. Some of the containers are refrigerated and can be used to transport food.

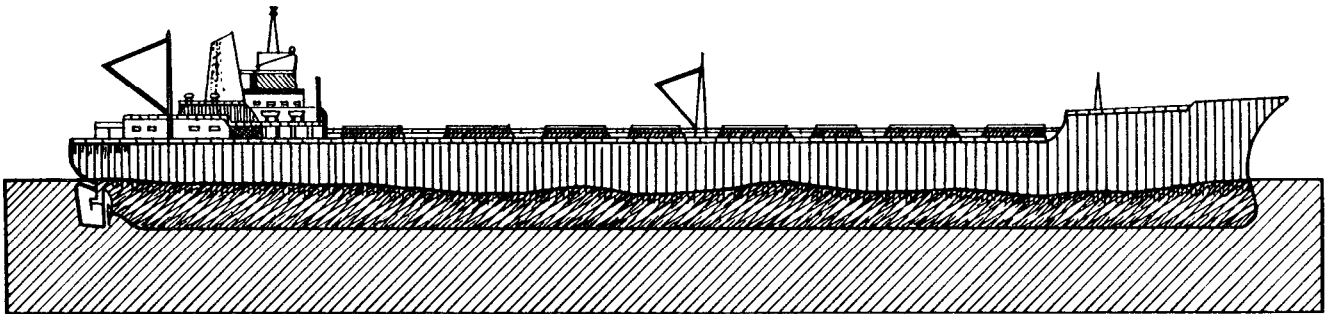

Dry Bulk Carrier

### 4. DRY BULK CARRIER

Large compartments in the holds of these ships are filled with grain, sugar, ores, fertilizers, and other dry materials. These ships are often seen at dock with long, round hoses or funnels that drop down into the holds to fill up the compartments. These ships are 700 to 800 feet long.

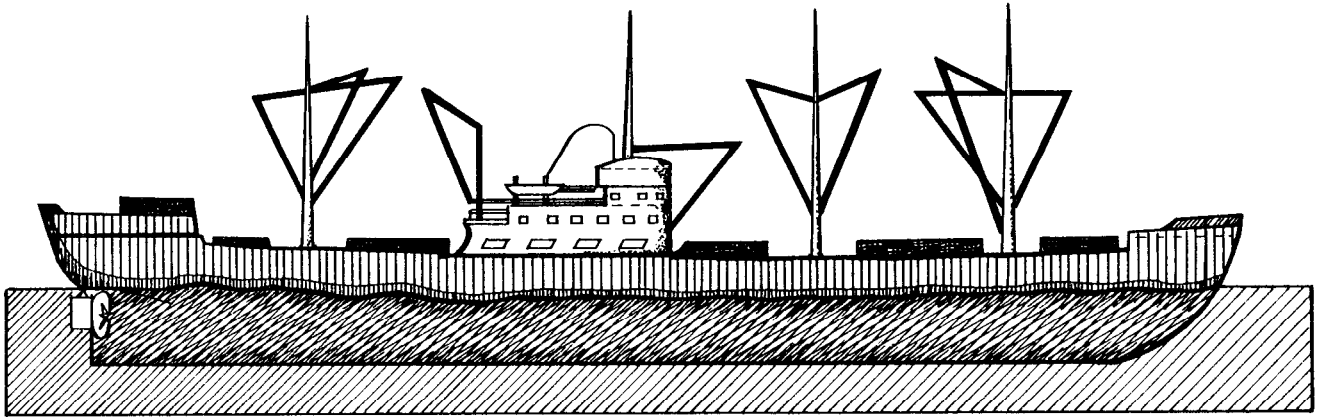

Cargo Ship

## 5. CARGO SHIPS

Cargo ships, or freighters, carry packaged goods of all kinds. These ships, unlike the large container ships, can carry containers of all sizes. The types of goods they carry vary greatly, from tractors, to canned foods, to cartons of apples. These ships have large derricks on board which are used to unload their cargo. The ships are about 900 feet long.

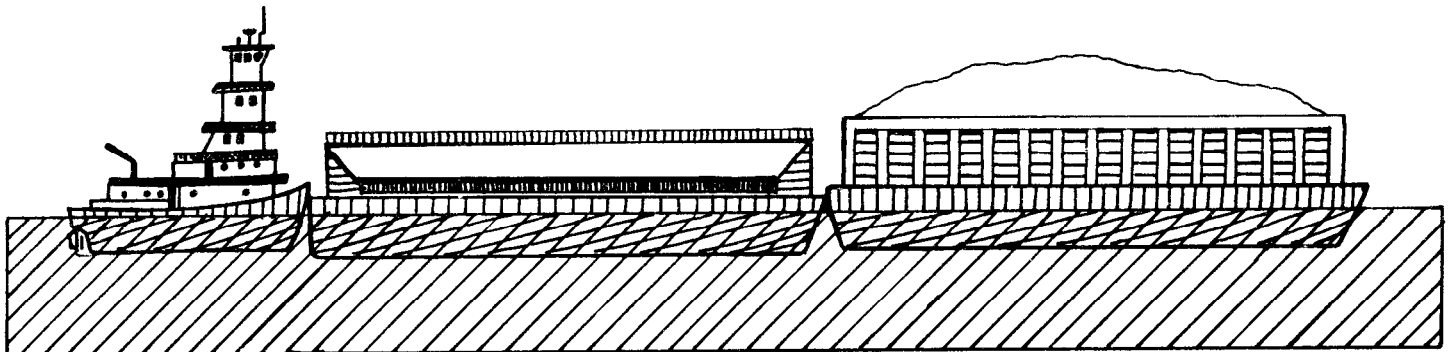

Tug and Barge

## 6. COLUMBIA RIVER TUGS AND BARGES

These tugs and barges are designed for use on the river only. They are a common sight moving goods up and down the river system. The bottom portion of many of the barges is designed to carry fuel while the upper part carries grain. With this design, they can transport grain from inland farm areas to Portland for export and pick up fuel to be carried upriver to ports in Washington, Oregon, and Idaho.

There are two types of tugs on the Columbia. The river tugs that move the barges are designed with a flat bow for pushing. The tugs that assist the ships into dock have rounded bows with tires attached to act as rubber cushions.

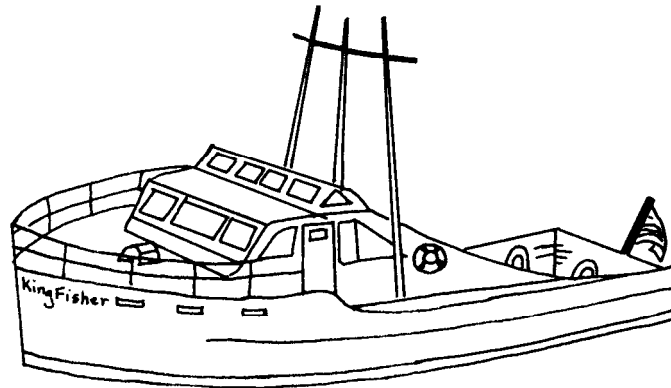

Charter Boat

## 7. CHARTER BOATS

Most ports and harbors in Oregon offer recreational boating facilities. One of the pleasure boats often seen in harbours is the charter boat. This boat can carry from 6 to 30 passengers and is used for ocean fishing, whale watching or, even pleasure excursions.

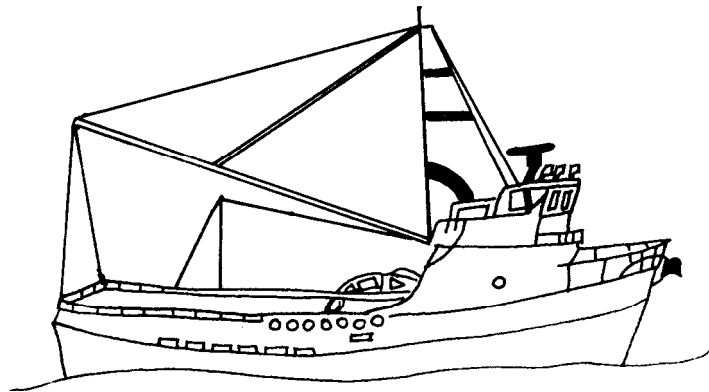

Commercial Fishing Vessel

## 8. COMMERCIAL FISHING VESSELS

Commercial fishing vessels dock in Oregon harbors. The type of equipment these boats carry is geared for the type of fish they are fishing for. For example, if they fish for bottom fish, they are equipped with large nets. Salmon boats have troll poles and lines and crab boats are equipped with crab pots and winches for pulling the pots on board.

### Vessels Chart

Picture Number	Type of Vessel	Cargo
	Car carrier	
	Dry bulk carrier	
	Cargo ship	
	Tanker	
	Columbia tug and barge	
	Container ship	
	Tug boat	
	Fire boat	

What features are designed into the ships to allow them to carry certain types of cargo?

Columbia River Ships Calendar

(a listing of ships which cross the Columbia River bar during a three-day period)

<u>Date</u>	<u>Vessel</u>	<u>Type of Ship</u>	<u>Foreign or U. S.</u>
6/15	<i>Seidai Maru</i>	Log ship	Foreign
	<i>Ocean Bridge</i>	Log ship	Foreign
	<i>Korean Amethyst</i>	Dry bulk carrier	Foreign
	<i>Sea Fortune</i>	Log ship	Foreign
	<i>Paclady</i>	Cargo	Foreign
	<i>Sammi Spirit</i>	Cargo	Foreign
	<i>Balder Oneen</i>	(Taking on fuel)*	Foreign
	<i>Keiyo Maro</i>	(Taking on fuel)	Foreign
	<i>Hoegh Minerva</i>	Cargo	Foreign
	<i>Balder Queen</i>	(Taking on fuel)	Foreign
	<i>Mercury Island</i>	(Taking on fuel)	Foreign
	<i>Sanko Stork</i>	Dry bulk carrier	Foreign
	<i>Star Eucre</i>	Cargo	Foreign
<i>Mercury Island</i>	(Taking on fuel)	Foreign	
6/16	<i>Oregon Rainbow</i>	Dry bulk carrier	Foreign
	<i>Lion of California</i>	Tanker	U. S.
	<i>World Diamond</i>	(Taking on fuel)	Foreign
	<i>Korean Ruby</i>	Dry bulk carrier	Foreign
	<i>Global Sun</i>	Dry bulk carrier	Foreign
	<i>California Highway</i>	Auto carrier	Foreign
	<i>Kiyoyasu Maru</i>	Tanker	Foreign
	<i>Colorado Highway</i>	Auto carrier	Foreign
	<i>Hitten</i>	Dry bulk carrier	Foreign
	<i>Ocelot</i>	Log ship	Foreign
<i>Hyuga Maru</i>	Container vessel	Foreign	
6/17	<i>Ping Chau</i>	Container vessel	Foreign
	<i>Neuguen II</i>	Cargo	Foreign
	<i>Sammi Superstar</i>	Bulk carrier	Foreign
	<i>California Highway</i>	Auto carrier	Foreign
	<i>Ever Order</i>	Container vessel	Foreign
	<i>Packing</i>	Cargo	Foreign
	<i>Huegh Dene</i>	Cargo	Foreign

\*Information not available for ships taking on fuel



---

## 7. Cargo Transfer

---

### Intent:

Through mapping and worksheet activities, students will become familiar with the transport of trade goods upon arrival at a port.

### Main Ideas:

1. The use of containers has revolutionized shipping.
2. Various types of machinery have been developed to handle the transfer of cargo at the docks.
3. Other transportation systems must be used once the cargo is unloaded at the docks.
4. Longshoremen are people who work on the docks to load and unload ships.

### Resources:

1. Port of Portland map
2. Illustrations of cargo handling machines
3. The worksheet, "Cargo Handling Machines and Their Uses"
4. "Using the Harbor" slide set

### Activities:

1. Cargo transfer equipment
  - Introduce and use the specialized cargo transfer worksheet.
  - Have students match equipment to the cargo to be moved. The following are examples.
    - a. Suction hose or clamshell scoop for unloading wheat grains and other dry materials such as fertilizers.
    - b. Lift truck for moving containers onto and off ships.
    - c. Crane and other equipment for moving containers onto and off ships.
    - d. Container. Container boxes are of two sizes--20 feet and 40 feet--and are used to transport a wide variety of materials, from pineapple to electrical equipment.
2. Transportation systems
  - Discuss with students that harbors are places where ships can be safely loaded and unloaded. Point out that they

are places where other transportation facilities must also be available. For example, railroads, highways, and river transportation systems all terminate at a port.

- Using the map of Portland, have students shade in the railroad systems, the road systems, and the water transportation systems to see how they all connect at the Port of Portland.
  - Tour the Port of Portland or the port nearest you. List as many types of cargo transfer equipment as possible.
3. Review the "Using the Harbor" slide set to identify as many types of cargo transfer equipment as possible from the slide set.

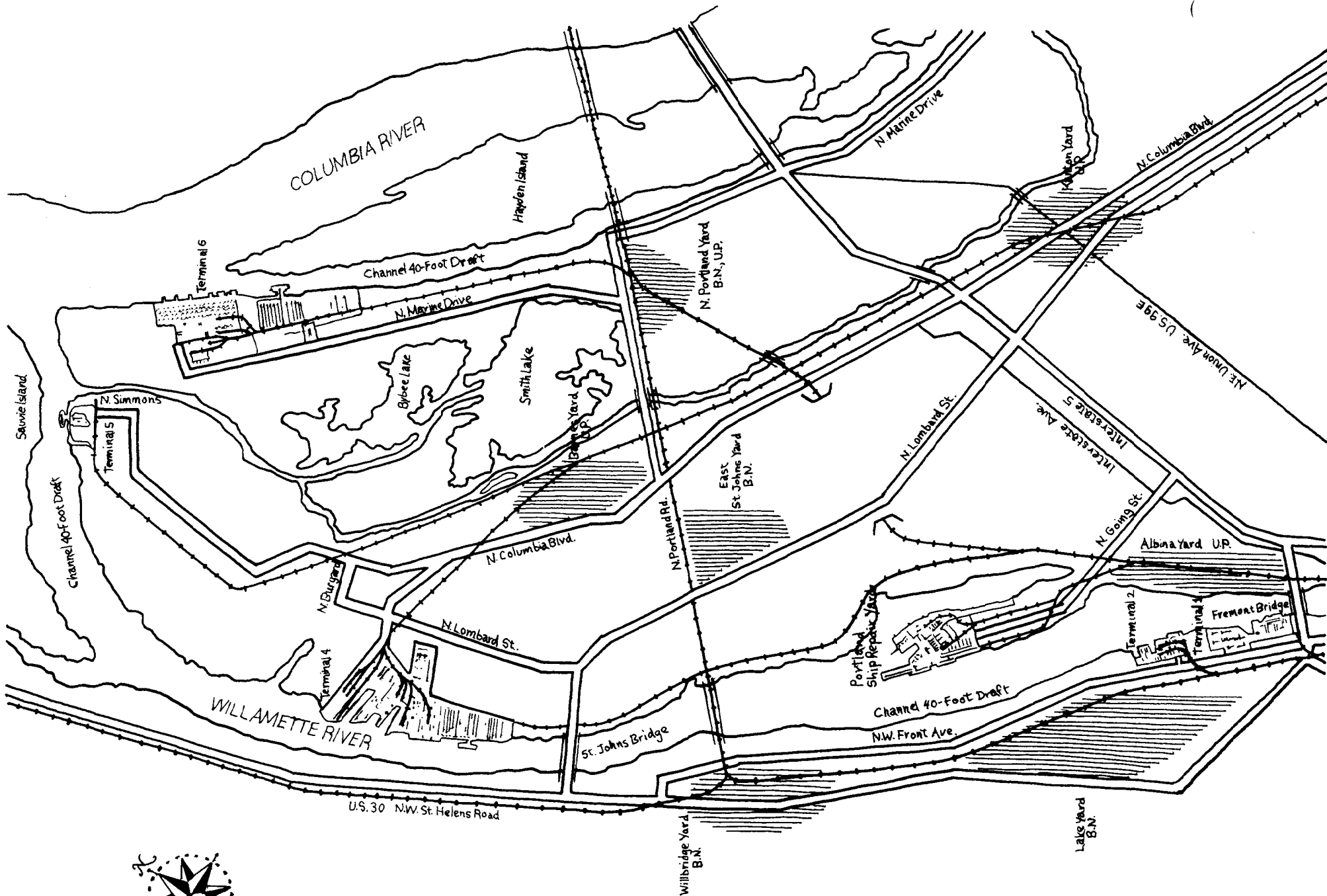

MAP OF PORT OF PORTLAND

Railroad 

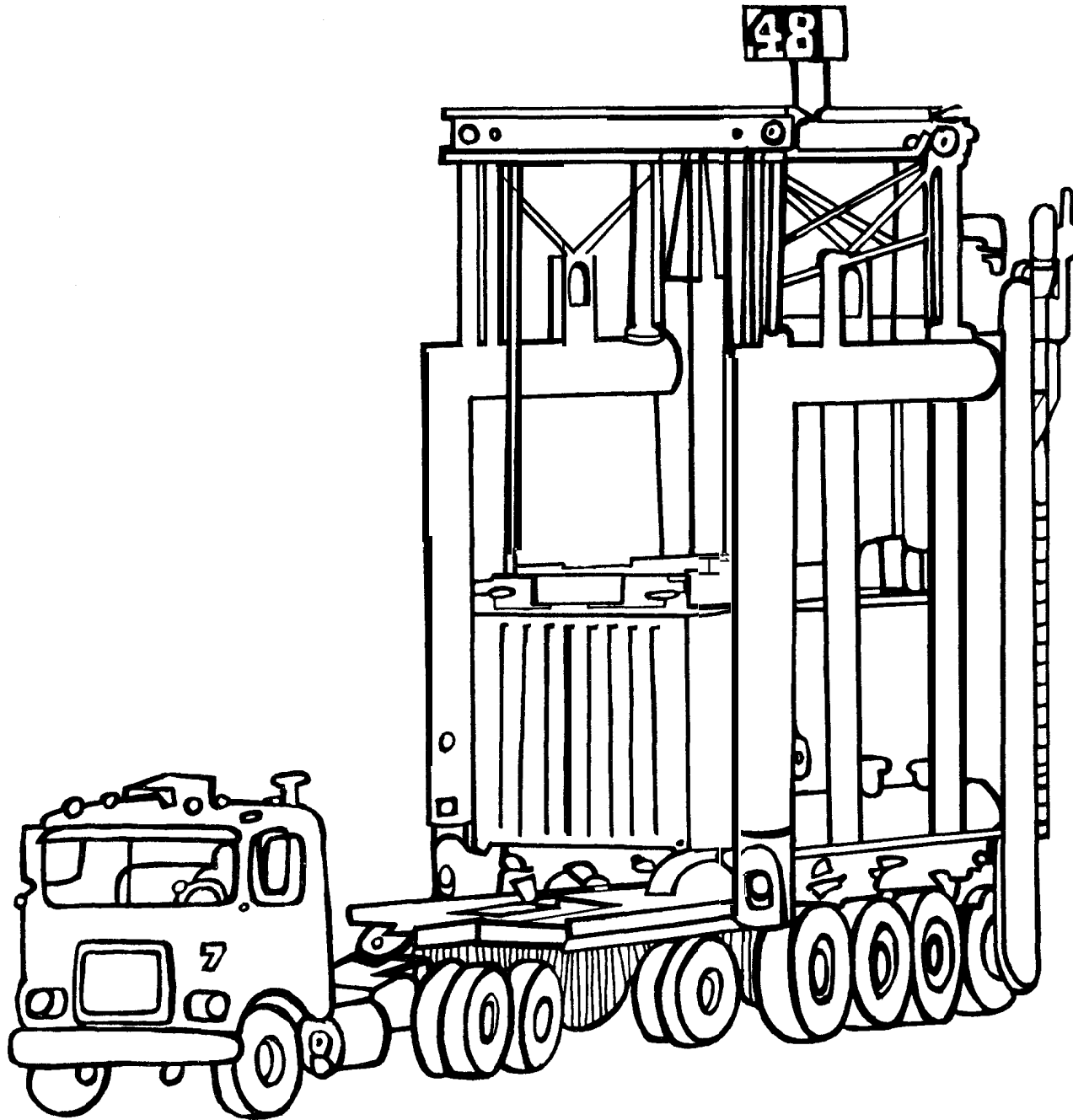

A transtainer unloads a container from a truck

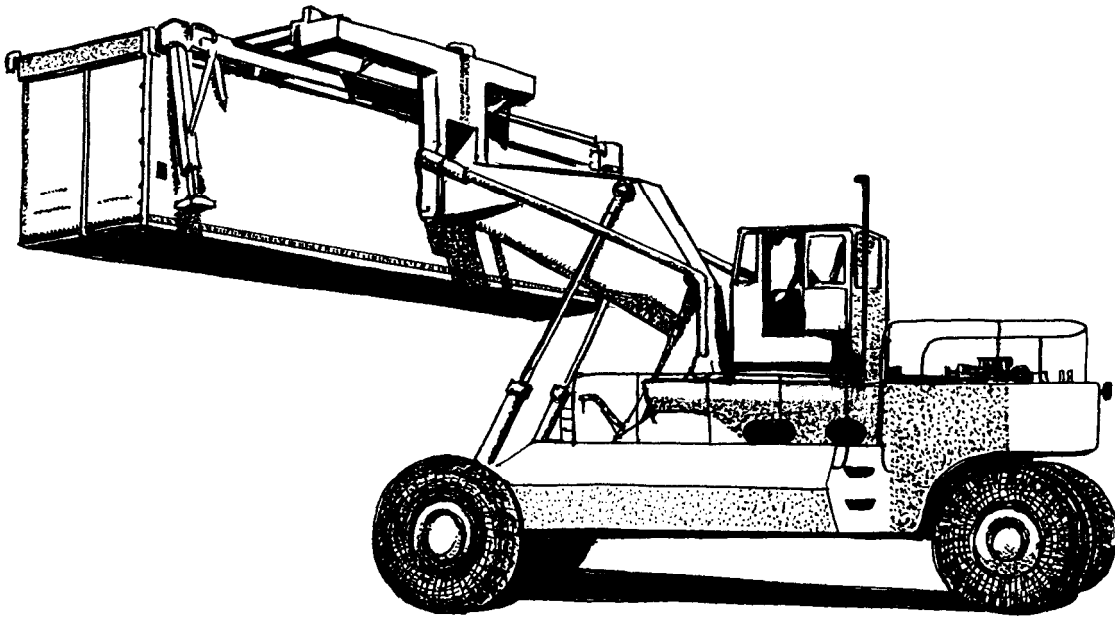

Lift truck for moving containers

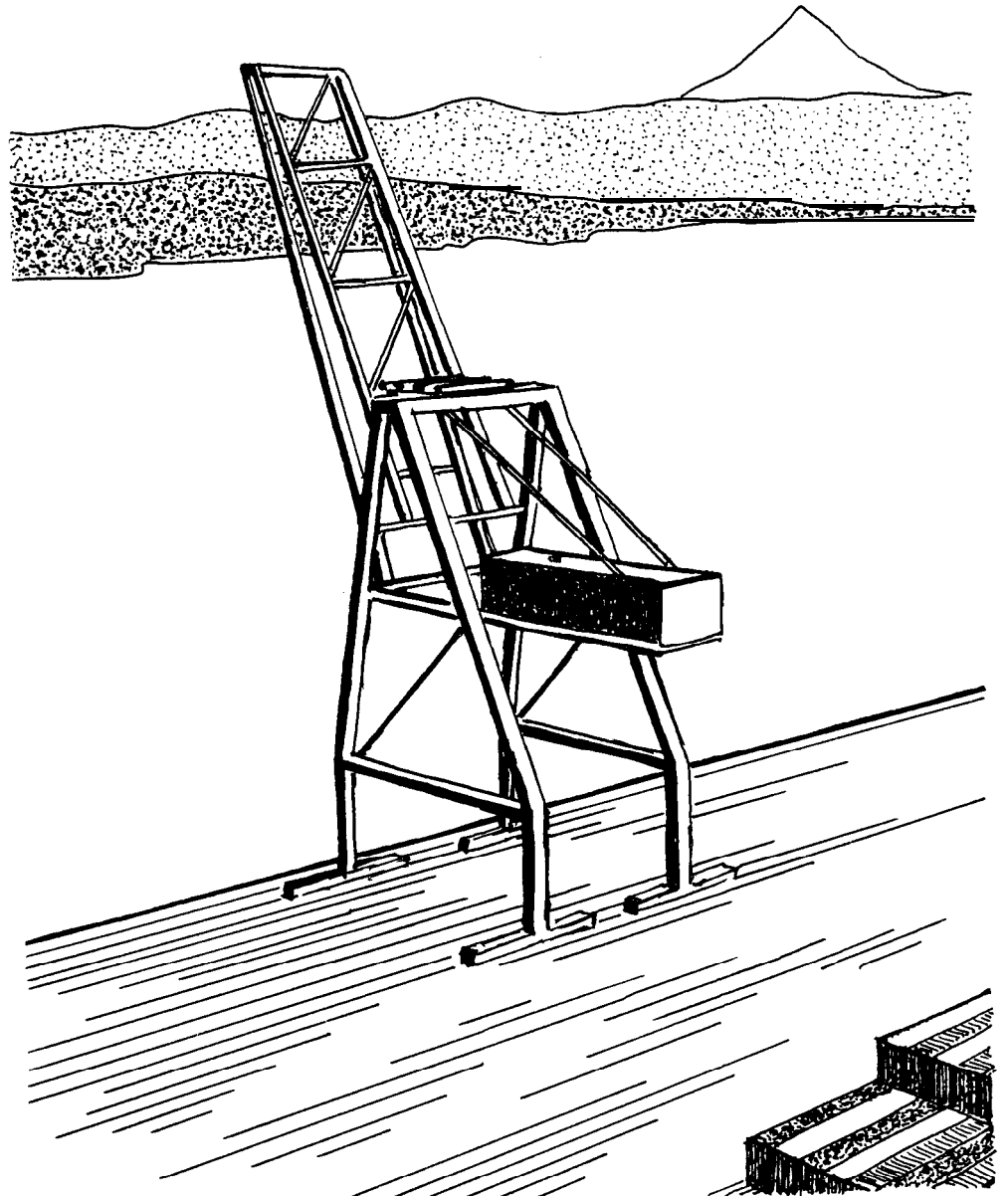

Shoreside crane for loading containers

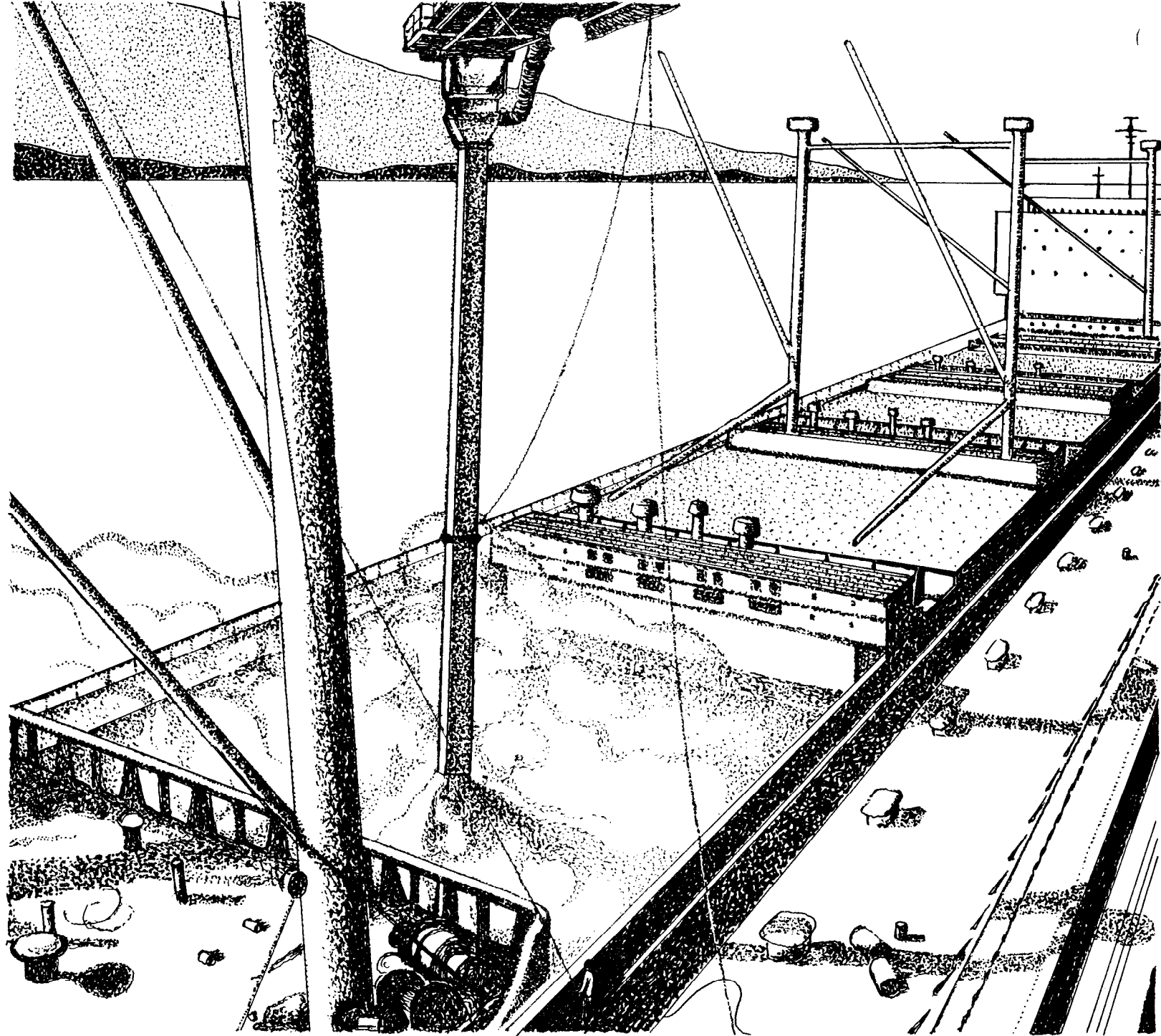

Suction hose and conveyor belt for loading grain and other material

Cargo Handling Machines and Their Uses

Name of Specialized Machinery	Description of Its Use

---

## 8. Ships' Communication

---

---

### Intent:

Through information sheets and flag activity, students will be introduced to the many means of communication used by ships.

### Main Ideas:

1. When vessels travel to foreign ports, crews may not always rely on language to communicate with other vessels.
2. When moving through fog or at night, ships use other means of communication, such as lights and horn blasts.
3. There are many ways of communicating when aboard a ship, including radio, satellite, flags, lights, and horn blasts.

### Resources:

1. International flags and pennants
2. Maneuvering and warning signals

### Activities:

1. Different forms of communication
  - Discuss with students the worksheet maneuvering and warning signals.
  - Discuss why whistle blasts and light flashes are necessary to use on ships.
2. Flag messages
  - Ships fly international code flags to relay messages and to make announcements. If messages are long, strings of flags are flown from the mast. Each international code flag stands for a letter in the alphabet as well as for a specific message.
  - Have students color the international code flags and learn two of the flag messages. Have students create their own flag messages by spelling out words using each flag to represent a letter in the alphabet.
  - In addition to the message flags, ships will also fly a house flag, which represents the company that owns the ship, the national flag of the country where it is registered, and the flag of the country it is visiting.



# INTERNATIONAL FLAGS AND PENNANTS



## ALPHABET FLAGS

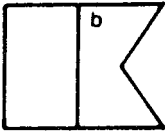

**Alfa**  
Diver down ; keep clear

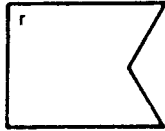

**Bravo**  
Dangerous cargo

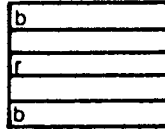

**Charlie**  
Yes

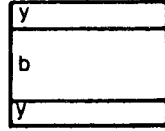

**Delta**  
Keep clear

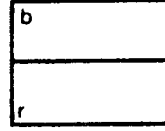

**Echo**  
Altering course to starboard

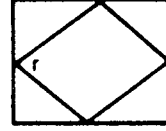

**Foxtrot**  
Disabled

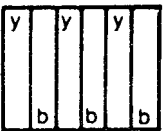

**Golf**  
Want a pilot



**Hotel**  
Pilot on board

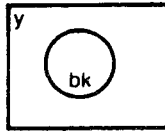

**India**  
Altering course to port

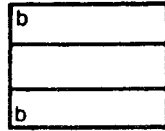

**Juliect**  
On fire; keep clear

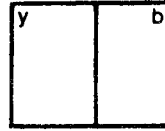

**Kilo**  
Desire to communicate

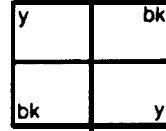

**Lima**  
Stop instantly

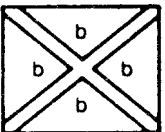

**Mike**  
I am stopped

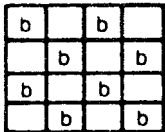

**November**  
No

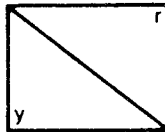

**Oscar**  
Man overboard

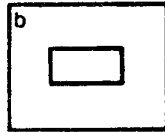

**Papa**  
About to sail

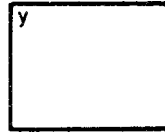

**Quebec**  
Request health clearance

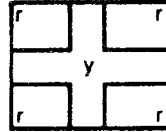

**Romeo**  
(No message)

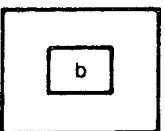

**Sierra**  
Engines going stern

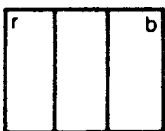

**Tango**  
Keep clear of me

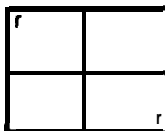

**Uniform**  
Standing into danger

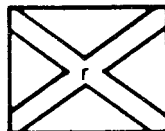

**Victor**  
Require assistance

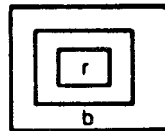

**Whiskey**  
Require medical help

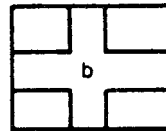

**Xray**  
Do not carry out your plan

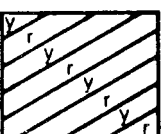

**Yankee**  
Am dragging anchor

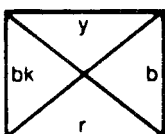

**Zulu**  
Require a tug

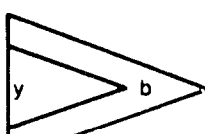

1st repeater

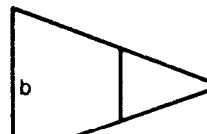

2nd repeater

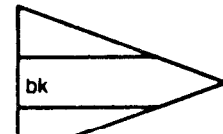

3rd repeater

## NUMERICAL PENNANTS

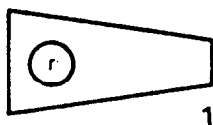

1

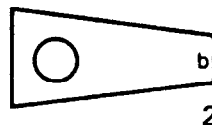

2

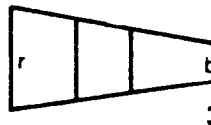

3

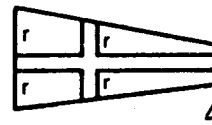

4

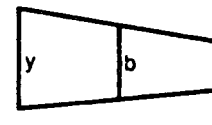

5

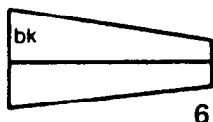

6

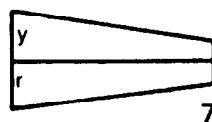

7

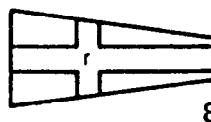

8

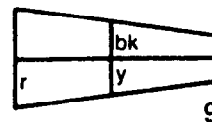

9

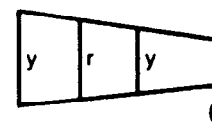

0

## Maneuvering and Warning Signals

### Whistle blasts:

When ships are in sight of one another:

One short blast means--"I am altering my course starboard."

Two short blasts mean--"I am altering my course to port."

Three short blasts mean--"I am operating astern propulsion."

When in sight of one another and one ship intends to overtake another:

Two prolonged blasts followed by one short blast means--"I intend to overtake you on your starboard side."

### Light flashes:

One flash means- "I am altering my course to starboard."

Two flashes mean--"I am altering my course to port."

Three flashes mean--"I am operating astern propulsion."

### Port and starboard vessel light:

A RED light designates the LEFT or PORT side of a vessel.

A GREEN light designates the RIGHT or STARBOARD side of a vessel.

Source: It's Your Port. Port of Vancouver, Canada. Western Education and Development Group.

---

## 9. Ships and How they Float

---

---

Intent:

Through the design of clay boats, students will learn how ships float and carry large loads of cargo.

Main Ideas:

1. Transportation by water is the least expensive method of transportation.
2. Water is able to support and float large quantities of cargo.
3. Ships are designed to carry maximum amounts of cargo.
4. There are marks on the ship's hull to indicate water depth and assist with loading.

Resource:

Boat design and loading lines information sheets

Activity:

Boat design

- Measure a given amount of clay and distribute it to each student. Have the students determine the volume of the clay and an equal volume of water. Let the students solve the problem of determining volume. Some will submerge the clay and measure the volume of water displaced. Others may wish to measure the clay in a container and measure an equal amount of water.
- Weigh equal volumes of clay and water. From the results, have students predict if the clay will float or sink.
- Have each student design a boat hull with his or her clay. See which student can design a boat that will carry more cargo than anyone else's,
- Discuss the problems of moving boats through the water with the greatest speed and least fuel possible. Would any of their designs be modified with these considerations in mind?
- Discuss the bow and stern designs from the fact sheet. How would these designs aid ships in moving through the water easily?

- Discuss the draft marks which are present on the ships. Why are these needed? (For loading and unloading vessels to navigate in shallow channels and to avoid overloading in rough seas.)
- Discuss with students that shipping is the cheapest method of transportation because of the volume that can be moved at the least cost for fuel, labor, and so on. Look at the chart below, which compares the cost of shipping to other means of transportation.

<u>Type of Shipping</u>	<u>Cost per Ton per Mile</u>
Ship	<b>\$0.35</b>
Barge	1.00
Rail	<b>3.00</b>
Truck	4.00

Additional activity:

- "Ships through the Ages: A History of Ships": Water Water Activity E-9. Available from the Extension/Sea Grant Program, Newport, Oregon 97365.

## KEEPING IT SAFE--BOAT DESIGN AND LOADING LINES

Today, almost every cargo ship has a steel hull. The front end of a ship is called the bow, and the back end is called the stern. There are many different shapes of bow and stern. Each is designed to help the boat do its job efficiently.

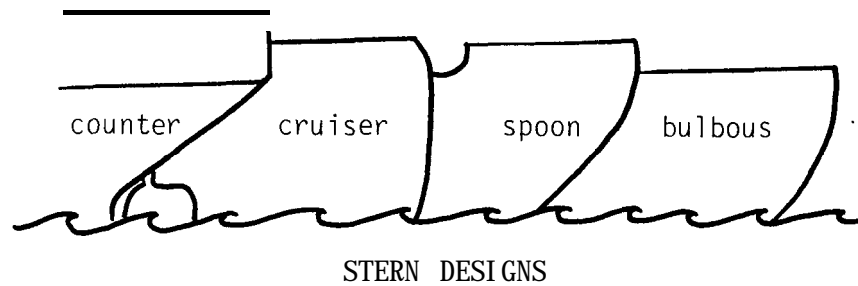
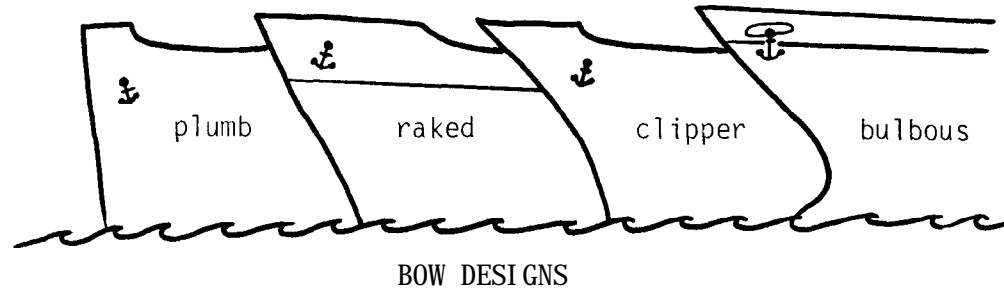

Painted on the bow and stern of large boats are vertical columns of numbers that show the distance, either in meters or feet from the bottom of the ship.

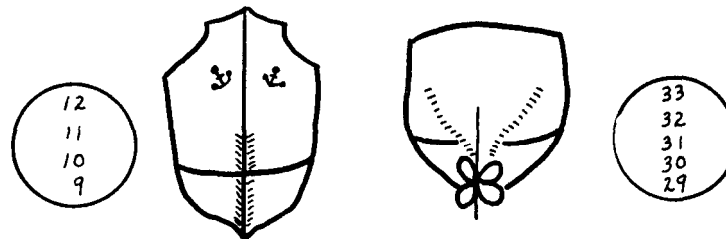

These draft marks show how deeply the hull is sitting in the water.

Source: It's Your Port. Western Education Development Group. University of British Columbia.

KEEPING IT SAFE--BOAT DESIGN AND LOADING LINES

Why does a ship made of steel float?

Anything will float in water if it weighs less than an equal volume of water. Volume is the space that an object takes up, so one cubic meter is a space one meter high, one meter wide, and one meter deep.

One cubic meter of water weighs 1,000 kilograms (1 metric ton).

One cubic meter of pine (wood) weighs approximately 650 kilograms (0.65 metric tons) so it will FLOAT.

One cubic meter of iron weighs approximately 7,800 kilograms (7.8 metric tons) so it will obviously SINK!

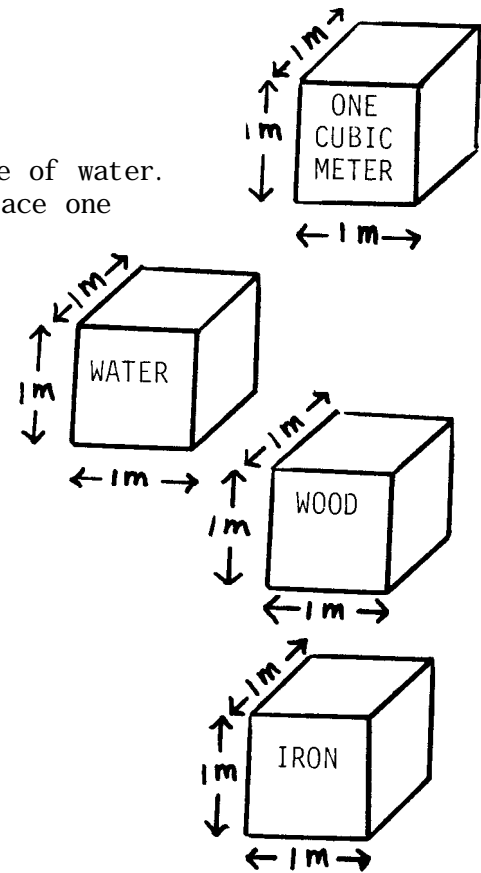

49

But--you can make the iron float if you roll it into a thin sheet, approximately five meters square, bend up the edges, and shape it into a simple "boat."

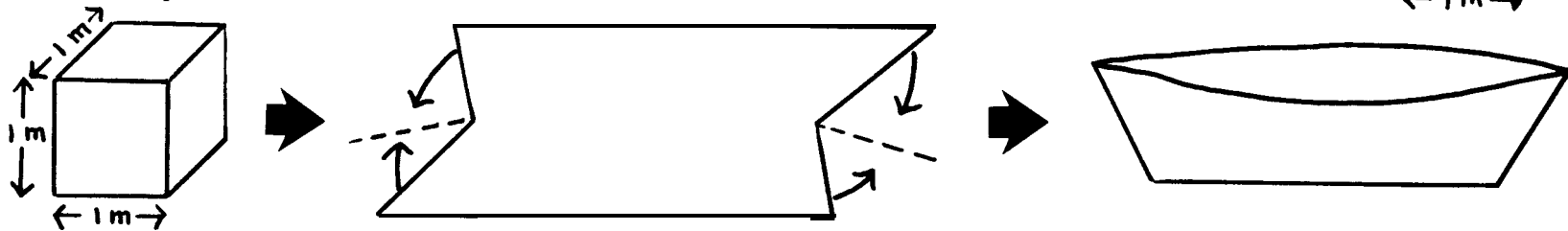

Although the iron still weighs 7,800 kilograms, it now takes up approximately 10 cubic meters of space. Since 10 cubic meters of water weigh 10,000 kilograms, the iron "boat" at only 7,800 kilograms is lighter and will float. It could even carry a cargo of 2,000 kilograms.

Source: It's Your Port. Western Education Development Group. University of British Columbia.

---

## 10. Home Goods Survey

---

---

Intent:

Through a survey of items in their homes, students will discover numerous items that have been imported.

Main Ideas:

1. People of the Pacific are increasingly interdependent as their imports and exports increase.
2. Many of the items we use in everyday life have been brought in through the harbor.
3. The printed label and manufacturer's mark on a product provide information about the product's country of origin.

Resource:

Home products chart (see below)

Activity:

Home products search

- Have students search at home for goods from other countries. Instruct them to look at labels or manufacturers' marks on items for their origin. Names of products may indicate the origin of the goods, as may the brand names of products. For example, cars, microwave ovens, and TV sets often carry Japanese brand or company names.
- The following day collect the information on the chalk board, listing products by country. See example below.

COUNTRY	Japan	Tai wan	Chi na	Australia
PRODUCT	Car Camera Microwave oven	Shirt Jeans	Blouse	Aluminum can (made from alumina from Australia)

- Many products are brought into the U.S. rather than producing them here because labor costs in other countries are much cheaper. For example, much of the clothing purchased in the U.S. is manufactured in countries where labor is cheaper.

Discuss with students what their home products survey might look like if they were conducting it in Japan or Australia. What differences might they find?

Home Products Chart (For Students)

Name of Product	Country of Origin	Number Found



---

## 11. Seaman's Diary

---

---

### Intent:

Students will improve their writing skills by keeping a daily diary.

### Main Ideas:

1. Various types of people make up a ship's crew.
2. Journals are kept and maintained on board ships.

### Resources:

1. Student journals
2. Ship's crew list

### Activity:

#### Daily diaries

- Prepare journals and distribute to students.
- Discuss with students the list of crew members. Let each student pick the member of the ship's crew he or she wishes to be during the course of this activity.
- Keeping the ship's diary may be used in conjunction with the simulation game "Cargo." The students may record in their journal their daily progress on their trip across the Pacific
- The cover page of the journal should contain:
  - a. Ship's name (may be selected by the class)
  - b. Cargo the ship is carrying
  - c. Destination
  - d. Crew member, title, and student's name
- Record the following daily:
  - a. Latitude and longitude as the students cross the Pacific
  - b. Weather conditions each day (may be actual conditions)
  - c. A daily entry to describe the day's happenings  
May be real classroom activities or imaginary ship's activities

## Making a Bound Book (Journal)

### Materials:

1. Paper for the pages (approximately 10 sheets of typing paper  $8\frac{1}{2}$ " x 11")
2. Cardboard (corrugated works best), 9" x 6"
3. Wrapping paper or fabric (inexpensive cotton)--two pieces 12" x 8"
4. White Elmer's-type glue (fabric) or rubber cement (wrapping paper)
5. Plastic Scotch brand colored tape,  $1\frac{1}{2}$ " to 2" wide
6. Scissors
7. Waxed paper
8. Stapler and staples

### Directions:

1. Select size and number. Fold sheets in half and firmly staple them together at the crease. (One can also stitch the pages together on a sewing machine. The thread should match the color of the pages.) A sheet of paper  $8\frac{1}{2}$ " x 11" will fold into a book 8" x  $5\frac{1}{2}$ ", and 5 sheets make 8 pages or 16 sides.
2. Cover one side of the cardboard evenly with a layer of glue. With glued side down, place each corner near the edge of a sheet of cut wrapping paper.
3. Turn the wrapping paper edges over to the unglued side of the cardboard, make the corners as flat as possible, and glue down. Set something heavy on top until it dries. Do the second cardboard piece in the same way.
4. Lay a piece of tape on a flat surface, sticky side up. The tape should extend at least  $1\frac{1}{2}$ " on the top and on the bottom sides of the book's length. Place book covers on the tape with a space about  $\frac{1}{4}$ " between them. Fold tape so that the inside and outside of the cover is taped.
5. Glue the pages into the book. Spread a thin layer of glue over the first and last pages, glue to cover, and place waxed paper between cover and remaining pages to prevent sticking. Place under weight until it dries.

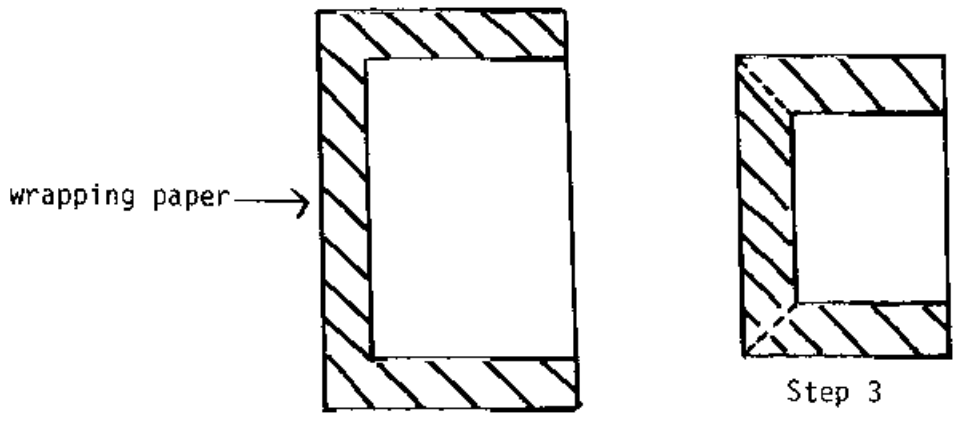
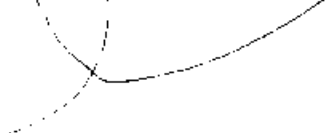

Step 2

Step 3

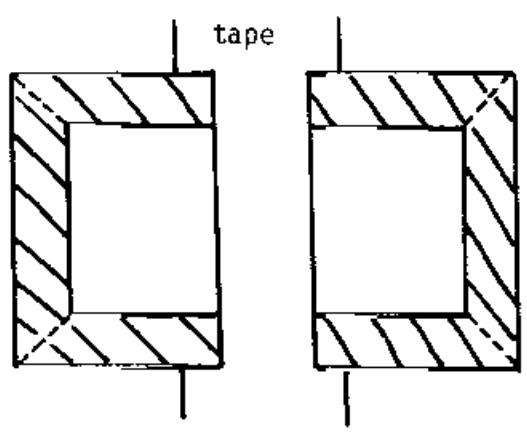

Step 4

MAKING A BOUND BOOK

## SHIP'S CREW

### MASTER OR CAPTAIN

absolute command of the ship  
ultimate responsibility for the safety of a vessel  
even if a pilot is aboard  
responsible for the lives of the crew  
answers directly to the owner of the vessel  
excellent seaman

### CHIEF OFFICER

second in command  
in charge of the bridge and deck work  
responsible for all cargo operations and vessel  
stability

### SECOND MATE

may assume command in an emergency  
performs navigational duties  
looks after all marine charts  
performs watch duty

### THIRD MATE

performs some navigational duties  
may assist the captain on the bridge when  
docking  
checks and maintains lifeboats

### BOSUN

responsible to see that all work is carried out  
on deck  
in charge of all able seaman

### QUARTERMASTER

- steers the ship

### ABLE SEAMAN

- qualified sailors
- general deck maintenance and cleanup
- perform watch duty

### RADIO OFFICER

- in charge of all ship-to-shore messages,  
including weather reports and navigational  
warnings
- listens for distress signals

### PURSER

- orders all provisions needed onboard
- keeps ship's accounts
- in charge of payroll
- in charge of stewards and cooks

### CHIEF ENGINEER

- complete charge of the engines

### FIRST ENGINEER

- assists chief engineer and supervises  
other engineers

### COOK

- cooks three meals a day
- responsible for all baking and food  
preparation

### STEWARD

- plans menus
- keeps track of food supplies and completes  
requisitions
- provides clean linen for crew

---

## 12. Harbor Careers

---

---

### Intent:

Through interviews and a review of career fact sheets, students will become familiar with the variety of jobs associated with shipping.

### Main Ideas:

1. Some jobs are associated with moving ships into and out of the harbor while others involve loading and unloading the vessels.
2. Other jobs may be associated with recreational activities or environmental sciences or commercial fishing.

### Resources:

1. Career fact sheets
2. "Using the Harbor" slide set
- 3 Career cartoon

### Activity:

#### Careers in harbors:

- Discuss with students and list on the chalk board as many jobs as they can think of that might be associated with harbors. Categorize the jobs as to shipping and trade, recreation, commercial fishing, or environmental science.
- Review the "Using the Harbor" slide set. Try to identify as many careers as possible from the slide set.
- Have the students read the career fact sheets and discuss the careers from the information provided. Gather additional information about various careers by interviewing people who work in harbors. Collect the information on a career profile sheet. From the information sheet, prepare a career cartoon depicting some of the duties of the people who work in harbors.

## Marine Biologists

### Duties:

Marine biologists study the plant and animal life in the ocean. Their interest may range from one-celled phytoplankton to whales. Depending on their specific job, some examine organisms, conduct experiments, and analyze data. Others work in the field collecting information about marine plants or animals. Some may tag seals while others collect data on different types of fish.

### Training:

Four years of college plus at least two additional years of study for a master's degree.

### Physical Requirements:

None

### Salary:

Beginning salaries may range from \$15,000 to \$20,000 per year.

## Fishermen

### Duties:

Fishermen must be able to operate boats and navigate at sea. They must also be able to operate heavy fishing equipment, such as large nets, traps, or fishing lines. When not at sea fishing, the fishermen must be at work on their boats, repairing and rigging the boats for the next trip.

Fishing boats carry a crew of two or three people. One is the captain (and often owner of the vessel). The hands are paid a share of the catch. Fishing trips last about a week.

### Training:

No formal schooling or training is required. On-the-job training and experience in handling and using boats and fishing equipment.

### Salary:

Varies widely. Depends on fishing season, price of the catch, skill of the fisherman, and so on.

## Bar Pilots

### Duties:

Guide ships into and out of the harbor. They go out to sea in pilot boats and transfer to the ship at sea. They operate the navigation equipment on the bridge of the ship and bring it into the harbor. They must be very familiar with the channel and entrance to the harbor to be able to bring the ship safely into dock.

### Training and Skills:

They must have experience in the Merchant Marines.

They must have experience as a shipmaster.

They must have a bar pilot's license, which involves training, often by apprenticeship.

### Physical Requirements:

Must be physically fit and agile.

### Salary:

\$80,000 to \$100,000 per year.



## Longshoremen

### Duties:

Longshoremen load and unload ships and move cargo in and out of warehouses. They work in the holds of ships, unhooking slings used to load logs. They load and unload containers in warehouses. They operate lift trucks, cranes, and other equipment.

### Training:

No specialized schooling is needed. New members admitted into the union are expected to have experience using heavy machinery. Most training to operate other types of equipment is gained on the job.

### Physical Requirements:

Must be physically fit and agile.

### Salary:

\$28,000 to \$30,000 per year.

# A day in the life of a Research Assistant

Those are the third and fourth seals I've observed today.

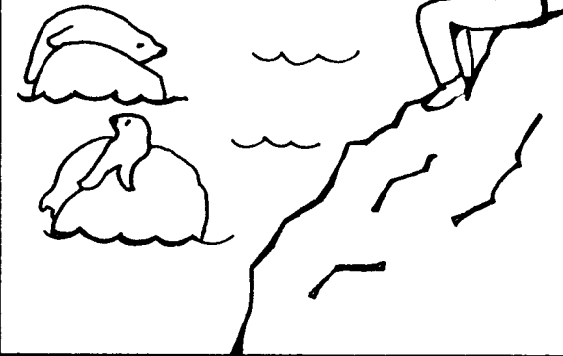

It was hard work to capture and tag this harbor seal!



I really like analyzing blood samples.

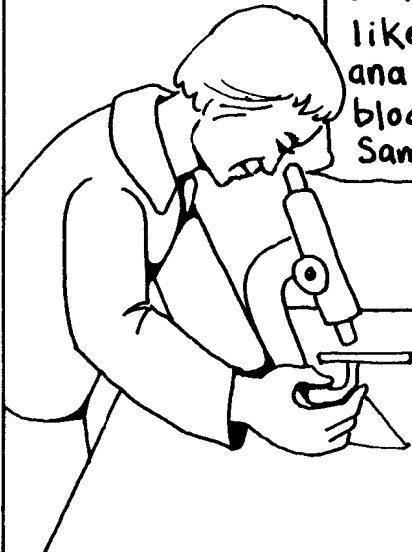

I spent four years in college and I'm still studying research reports!



I'll take a break from writing this research report and go clean the lab.

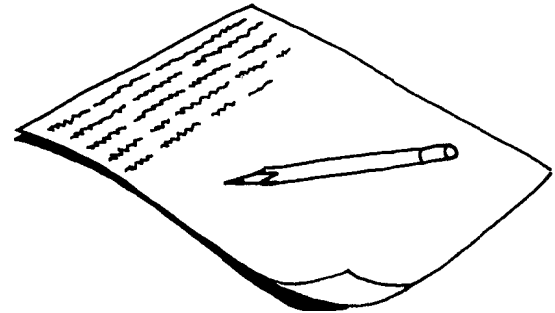

## **The Harbor Environment**

---

### 13. Habitats of the Columbia Estuary

---

---

#### Intent:

Students will discover habitats and animal adaptations to these habitats through mapping and adaptation activity.

#### Main Ideas:

1. The Columbia River estuary has many different habitats.
2. Three major habitats are tidal flats, tidal marshes, and open water.
3. Some plants and animals are found in all three major habitats of the Columbia River, while others are restricted to specific areas.
4. Many areas of the Columbia River estuary have been modified by people for specific needs such as sites for industrial development and marinas.

#### Resources:

1. Description of adaptations
2. Description of three major habitats
3. Map of the habitat areas in the Columbia River estuary
4. Short story, "Cradle of Life--the Columbia River Estuary" (see Part Two)
5. Vocabulary list for "Cradle of Life" (see Part Three)
6. Reading, "Estuaries"

#### Activities:

1. Read the story "Cradle of Life--the Columbia River Estuary"
  - Distribute the story and have the students read during class.
  - Discuss the ideas from the story.
    - a. What is an estuary?
    - b. Describe the food chain for a salmon.
    - c. Why are salmon having problems in the Columbia?

## 2. Columbia River habitats

- Distribute the map of the habitat areas in the Columbia River estuary and the data sheet for fish and wildlife of the Columbia River.
- Have students color different habitat areas on the map, i.e., salt marshes green, mud flats and beaches brown, and water blue.
- Attach tag cards with names or drawings of the animals on the correct habitat, i.e., plankton in the open water and shorebirds on the mud flats.
- Discuss with students the list of adaptations that animals have which suit them for the habitat in which they are found. See the list of adaptations and list some of them on the chalk board. Have the students think of other adaptations. Match the adaptations to the animals from the fish and wildlife identification sheet.

## Adaptations

<u>Adaptation</u>	Use	<u>Animal</u>
long, pointed bill	for stabbing and spearing fish	great blue heron
long legs	for wading in shallow water	great blue heron
webbed feet	for swimming	gull, scoter, cormorant
short, pointed bill	for picking food from sand	shorebirds (western sand piper)
slime and scales	for protection from constant exposure to water	fish
layers of blubber	for warmth	seal and sea lion
thick, dense fur	for warmth	seal and sea lion
webbed feet and legs modified into flippers	for swimming	seal and sea lion
flat shape and eyes on one side of head	for lying flat in sand	starry flounder

## Three Major Estuarine Habitats

### Tidal marshes

Located around the edges of the estuary. These areas have high enough elevation above the water that marsh plants can grow. They are under the influence of salt water since the area is inundated with salt water during the high tides. They are occupied by salt-tolerant plant species: pickle weed, salt grass, arrow grass, tufted hair grass.

Plants growing in the tidal marshes are most important to the estuary after they die and break down into bits of dead plant material (detritus). The material is carried into the estuary by high tides and becomes food for animals that filter bits of food from the water.

### Tide Flats

These areas are exposed by the low tides and are made of sand and mud. The areas are intertidal, that is, exposed at low tide but covered with water at high tide.

They are occupied by a number of animals which live at the surface or burrow into the mud--polychaete worms, mud and sand shrimp, amphipods (beach hoppers), shore birds (sandpipers, and so on).

### Open Water

This is the area where water is always present. It is occupied by a number of species of fish--salmon, tomcod, smelt--and by phytoplankton (plants), zooplankton, crabs, and water fowl (scaup, pintail, widgeon).

HABITAT AREAS IN COLUMBIA ESTUARY

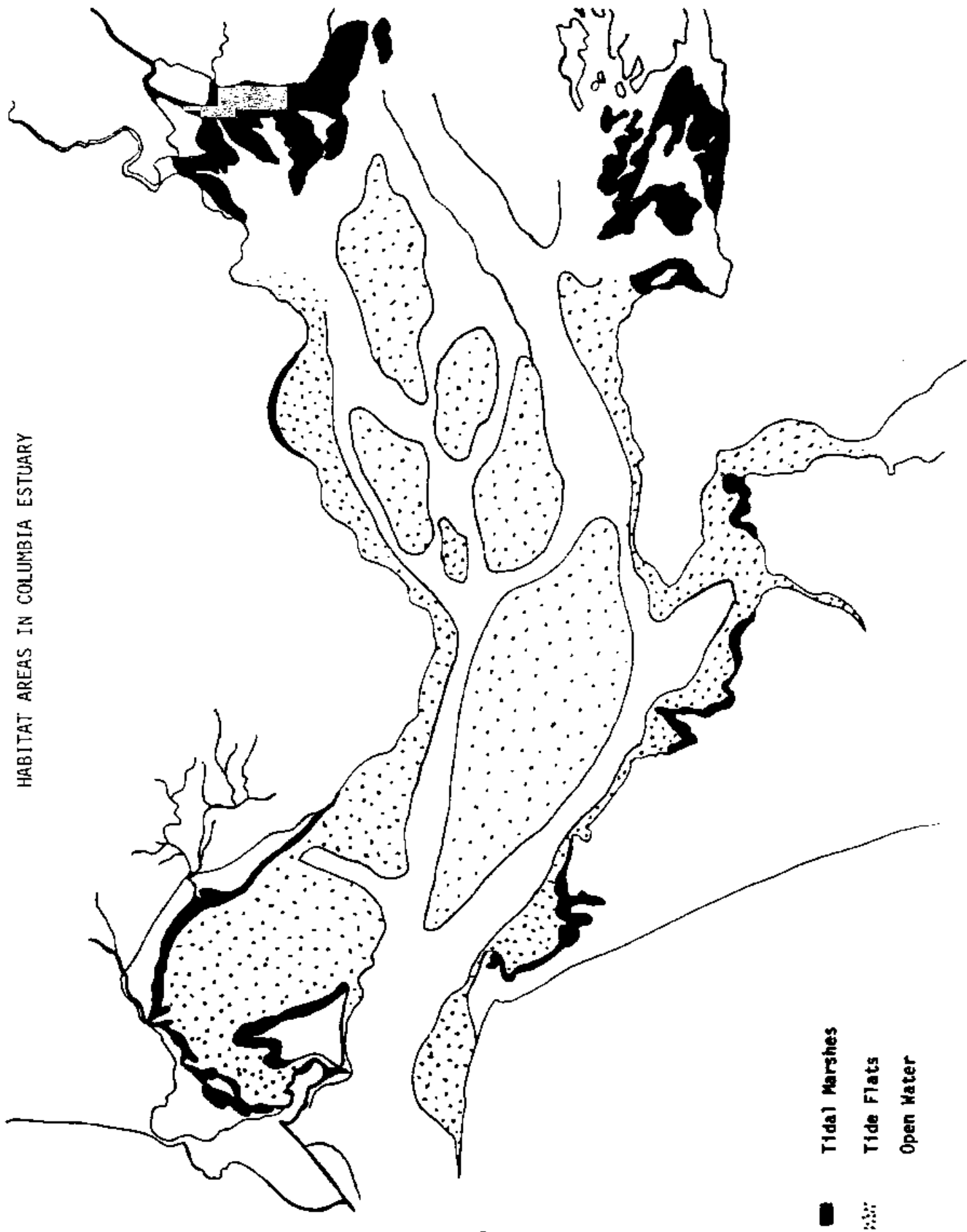

- Tidal Marshes
- Tide Flats
- Open Water



## Estuaries: a Student Reading

Estuaries are places where rivers meet the ocean and where the salt water and fresh water mix. Oregon's estuaries were formed when river valleys, which were carved by coastal rivers, flooded as sea level rose. These resulting areas of shallow water are sheltered and protected from the constant motion of ocean waves. All of Oregon's harbors are estuaries.

In addition to having sheltered water, estuaries have very productive water. Sunlight can penetrate the water, and nutrients carried in by the river provide ideal conditions for the growth and production of tiny plants called phytoplankton. In addition to encouraging the abundant growth of phytoplankton, the shallow areas and margins of the estuaries support marshes and seaweeds. These plants, although not directly eaten by many animals, die, decay, and break down into tiny particles of material called detritus. Detritus is used as food by many animals which live in the estuaries. With such high levels of productivity, estuaries are abundantly supplied with food materials. As a result, estuaries support a rich variety of animal life.

Many animal species will migrate into the estuaries to lay their eggs. This insures that newly hatched or young animals will have abundant food supplies from the rich stores of the estuaries. In addition, juvenile species enter the estuaries to feed. Since a number of animals will use the estuaries for their young, estuaries are often called the nurseries of the sea.

Because of their sheltered nature, estuaries play an important role in human activities. They are the site of the shipping and trade between countries as their sheltered waters provide safe areas to dock ships. They also attract commercial fishing industries as the fishing boats dock and load and unload their catch in estuaries. Seafood plants are built on or near the water to service the boats. Estuaries are also important recreational areas, and sport boats use the estuaries for docking. Estuaries are also popular places for fishing, sailing, clamming, and many other activities.

All of the activities just listed take place at the water's edge. As developments crowd down to the shores, pilings and docks are built. Mud flats and marshes are filled to make way for warehouses or canneries. The very areas that are so important for supporting and feeding fish and wildlife are destroyed to make way for human activities.

In addition to the destruction of shoreline and shallow water areas, the water becomes polluted with runoff from the land. Chemicals in the soils from agriculture leach into the river and estuary waters. Disposal of industrial wastes seeps into the waters, and runoff from logging and other activities flushes topsoil into the estuary, smothering spawning grounds.

The marsh areas bordering the estuary absorb many pollutants which enter the water; fortunately, these areas have the ability to filter them out. These marshes operate much like a sponge. Not only do they absorb outgoing wastes that would pollute the bays, but they capture incoming pollutants as well. These marshes help to keep the harbors and nearshore waters clean. Unfortunately, salt marshes can process and filter only so much water. Marsh areas have been diked and drained to make pastureland, filled to build warehouses, and dredged for dock areas.

Careful planning must be conducted if estuaries are to meet all the demands we are placing on them--a need for fresh, clean water to support fish, shellfish, and waterfowl; the need for shoreline space for shipping, commercial fishing, and housing; and the need for clean natural areas for recreation activities.

---

## 14. Natural Habitats and Human Uses of Harbors

---

---

### Intent:

By comparing historic maps to current maps, students will be able to see how natural areas are changed.

### Main Ideas:

1. Waterfront areas are desirable for developments of various ports.
2. Natural habitats are modified for specific needs such as shipping, housing, and recreational activities.

### Resources:

1. Maps of Columbia River estuary, 1814 and 1960
2. Map of Astoria dock areas
3. Description of the three maps
4. Dodecahedron pattern and directions
5. Map of Astoria waterfront area

### Activity:

#### Mapping habitat destruction

- Distribute the 1814 and the 1960 maps of the Columbia River estuary as well as the map descriptions.
  - a. Students may color the maps and list changes on the map to show changes to islands, shoreline, and jetties.
  - b. Teachers can discuss these changes with students on an overhead transparency of each map shown individually or as an overlay map aid.
- Pass out the map of the Astoria waterfront and the Astoria dock areas. Have the students highlight the 1884 shoreline and use two colors to shade the past and present areas.
  - a. Estimate the amount of area of natural habitat that has been lost to city development since 1884.
  - b. A similar activity may be used for the Astoria dock area.

- If your local area borders on water, compare your local situation with the Astoria area. How much natural habitat has been lost to development? Cities, particularly those with dock areas, tend to grow out into the natural area by filling in mud flats and salt marshes or shallow water areas to create building sites.
- Have students read the student reading section on estuaries. Be sure they understand the following concepts.
  - a. Estuaries provide harbors for shipping and trading activities.
  - b. Estuaries are important areas for fish and wildlife.
  - c. Estuaries are often called nurseries because they are used as sites for spawning and rearing of many ocean species.
  - d. Estuaries are being destroyed by human activities such as filling in shallow shoreline areas.
  - e. Estuary waters are becoming polluted from runoff from agriculture, industrial wastes, and other sources.

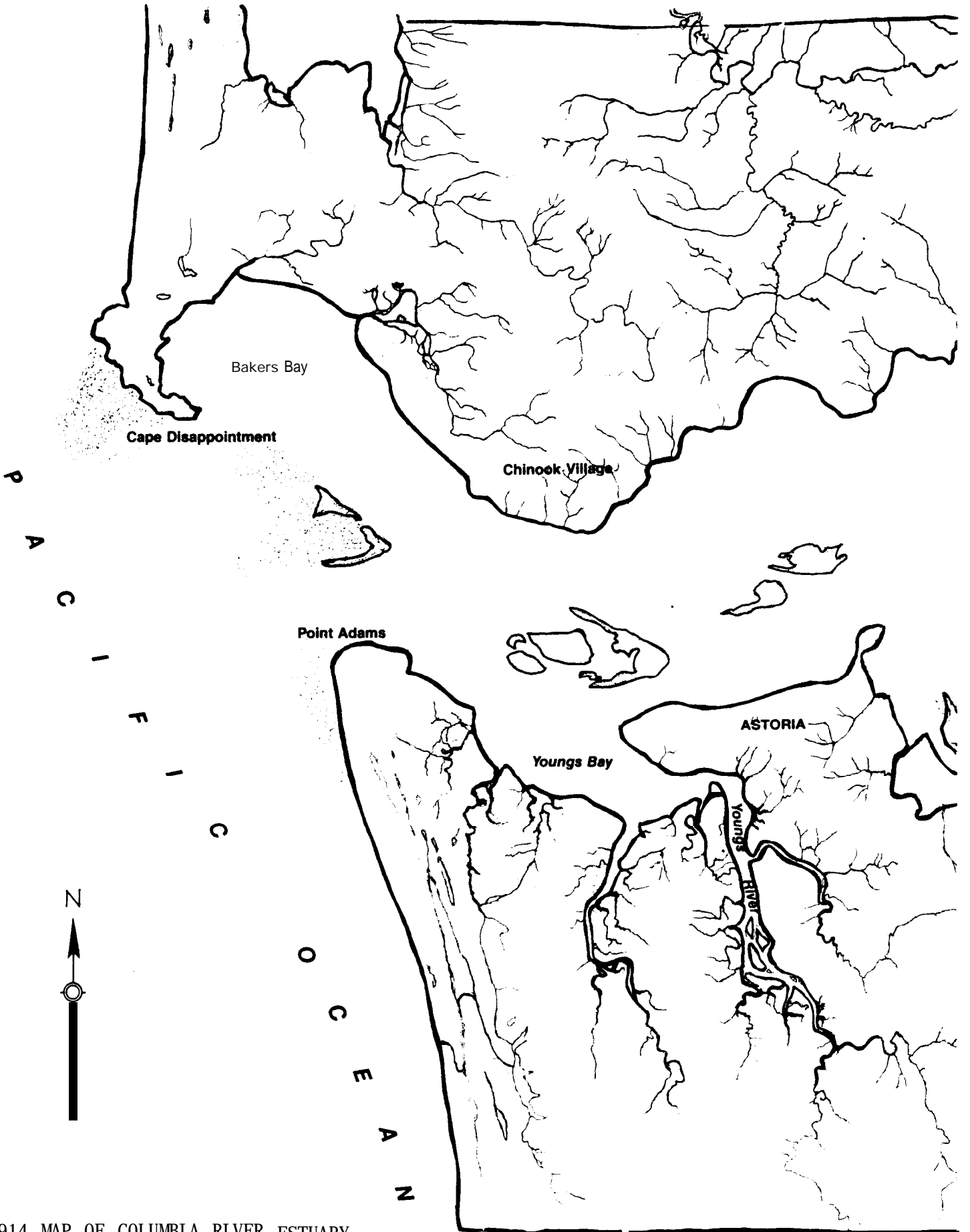

1914 MAP OF COLUMBIA RIVER ESTUARY

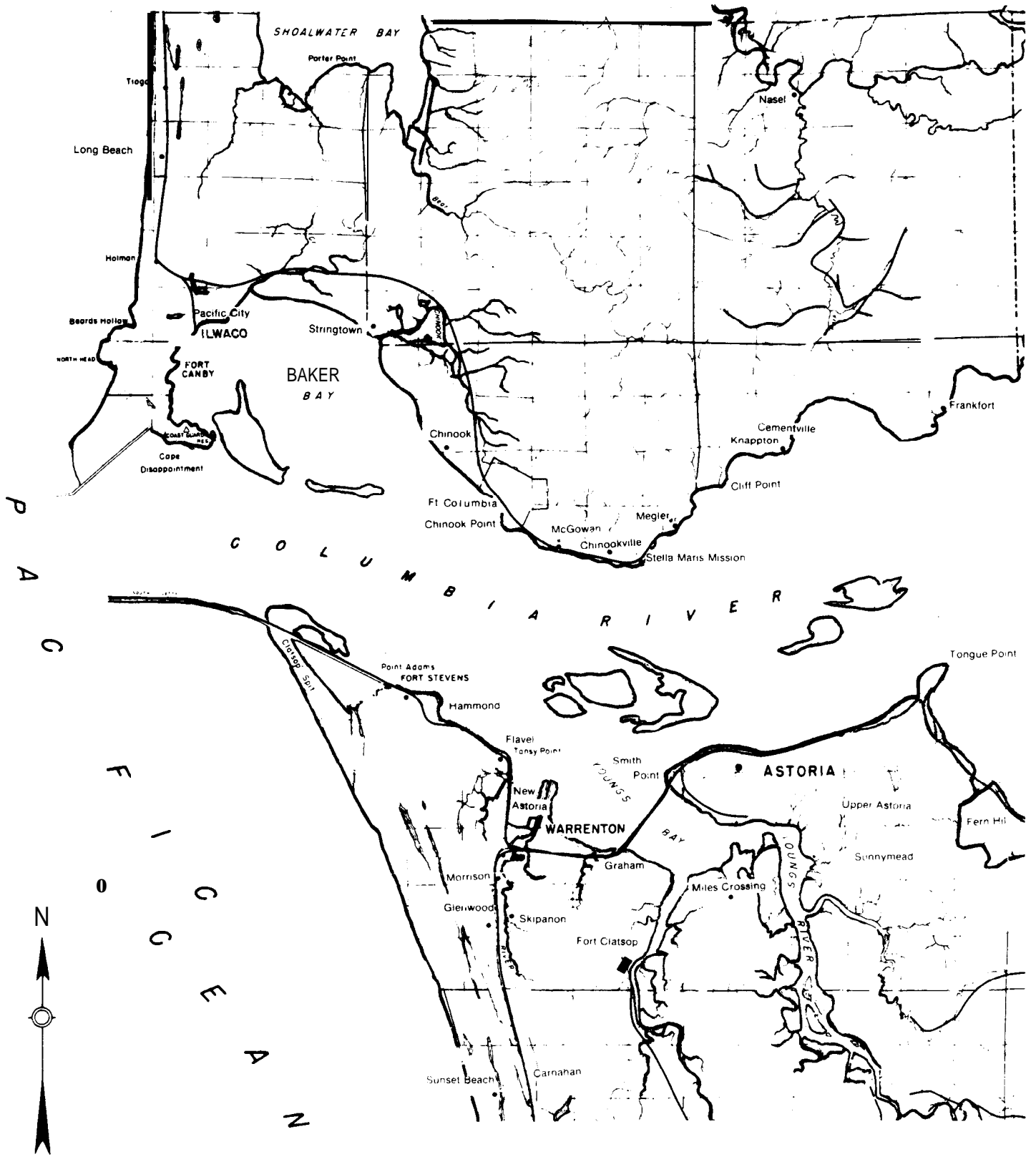

1960 MAP OF COLUMBIA RIVER ESTUARY

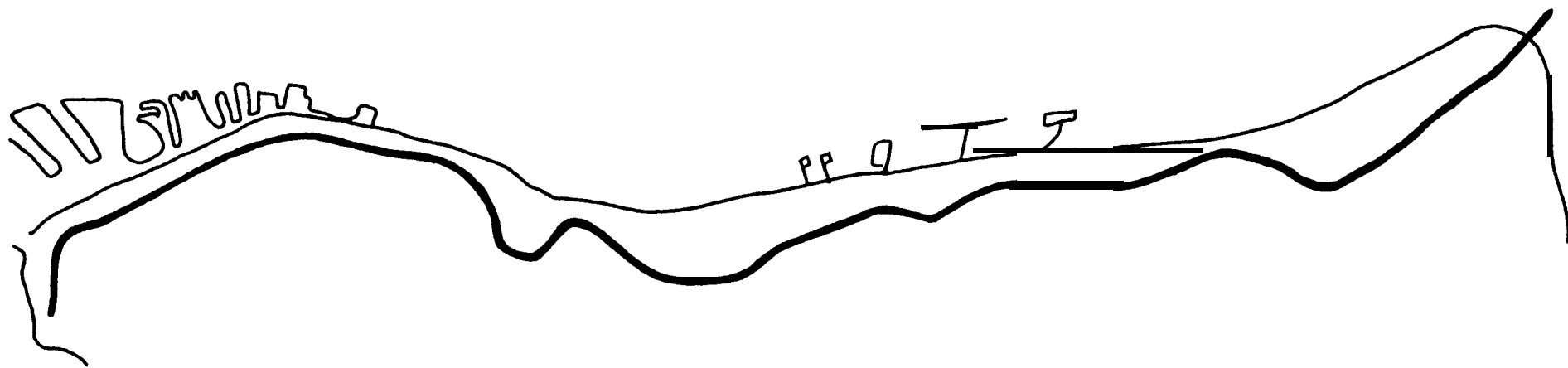

ASTORIA DOCK AREA. The dark line indicates the original shoreline.

0 1000 2000 = feet

## Description of Maps

The 1814 and 1960 maps of the Columbia River show changes which have occurred to the mouth of the Columbia after construction of jetties. Jetties are large structures of rock which extend from the shoreline out into the ocean. They are built to protect the mouth of the harbor and reduce the amount of dredging needed to maintain the channel. Once the jetties are constructed across the beaches and into the ocean, they interrupt the flow of sand up and down the beaches. Sand will be trapped behind the jetties, resulting in the build-up of beaches and sand dunes in the jetty area. So much sand has collected behind the South Jetty that the shoreline has extended over a mile. Also note the beach building which has occurred behind the North Jetty.

The map of Astoria shows how the waterfront of Astoria has been changed. Note the old water line. The area from the old water line to the present water line has been filled in with soil and dredge spoils to make space for homes, streets, and businesses. The Astoria docks, in the Smith Point area, have also been constructed in what were once shallow water areas.

These filled and jetty areas are easily shown on a map. However, some of the most drastic changes to bays and harbors have been the dredging to build and maintain ship channels. These changes are under water and not easily shown. However, the disturbance to the harbor floor, the silt and sand that is stirred up into the water, and finally the dumping of dredged mud and sand all have had a profound effect on the harbor and the animals which live there. For example, feeding areas for fish and migrating birds have been destroyed. And fish habitat and larval animals are disrupted by the sand and mud stirred into the water by dredging.



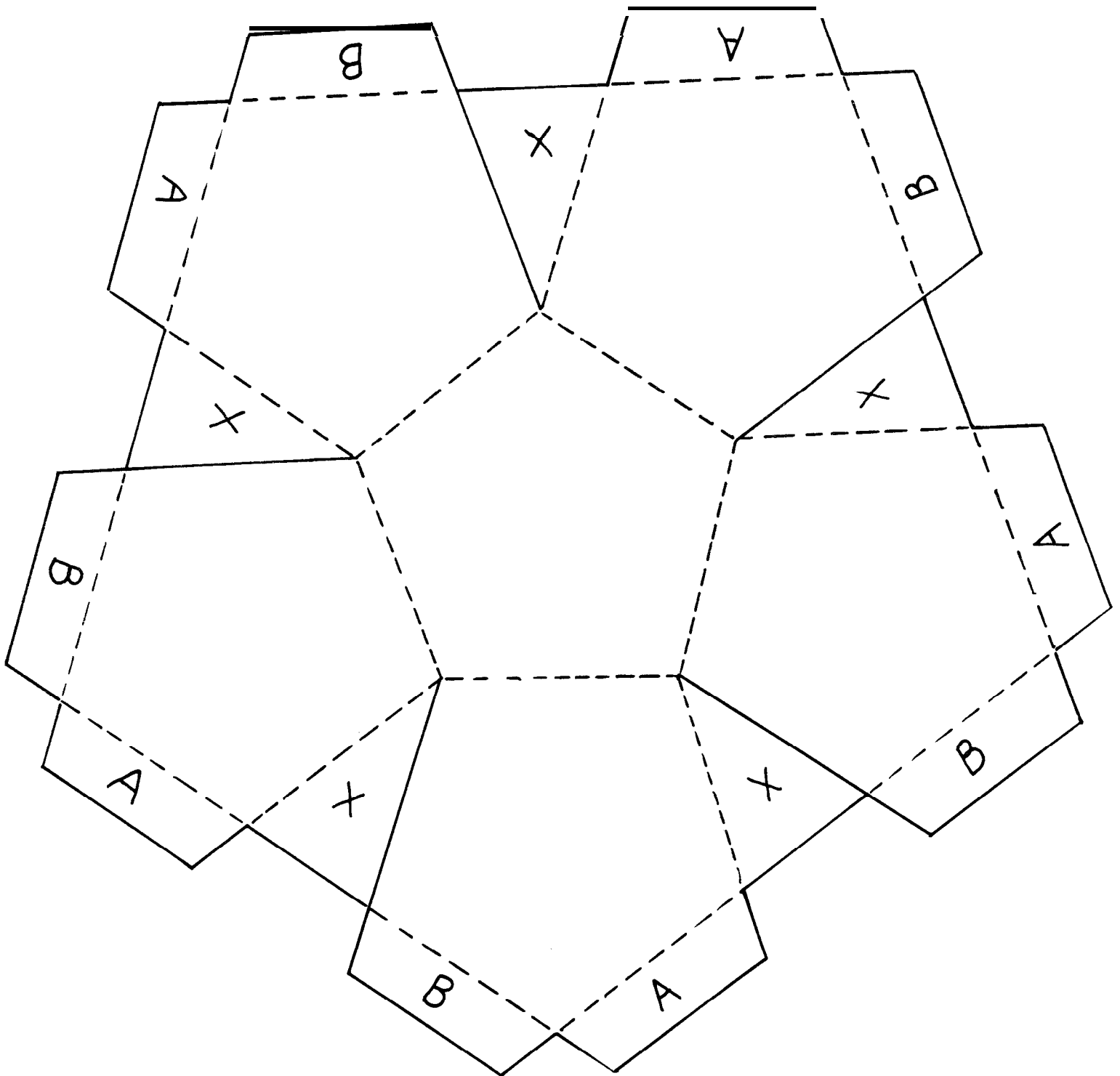

DODECAHEDRON PATTERN

Columbia River

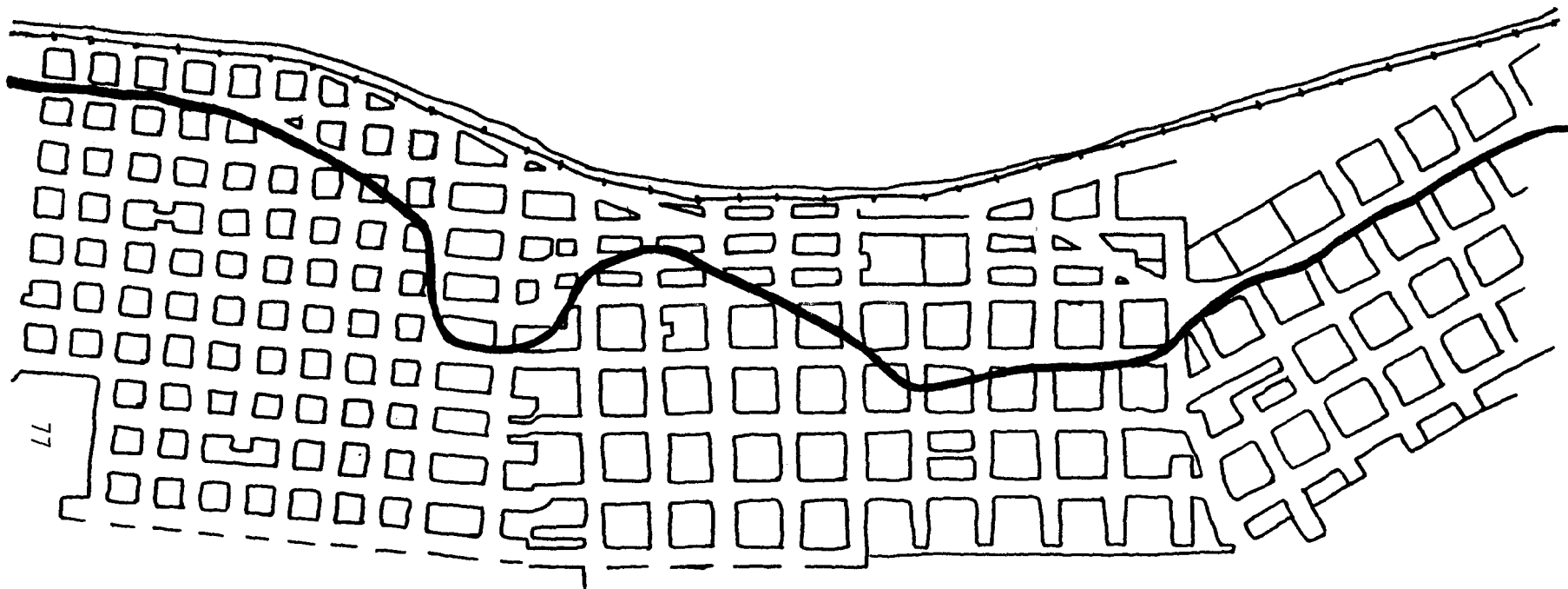

ASTORIA WATERFRONT. The dark line indicates the original shoreline.

0 50 100 feet

---

## 15. English Sole Life Cycle

---

---

### Intent:

Students will gain an appreciation of the use of estuaries by fish and wildlife through a study of the life cycle of the English sole and a review of waterfowl.

### Main Ideas:

1. Estuaries are vital areas because they provide spawning and nursery grounds for juvenile and larval marine creatures.
2. English sole juveniles enter the estuary to feed and grow from April through October.
3. An estuary's water is rich and provides abundant food and protection for juvenile and larval marine creatures.
4. Many waterfowl use estuaries during their life cycle.

### Resources:

1. Description, "Life Cycle of the English Sole"
2. Key to life cycle of the English sole
3. Worksheets
4. List of birds dependent on estuaries

### Activities:

1. The English sole is a good example of creatures which use the estuary to rear their young.
  - Discuss the English sole life cycle with the students. Have them place the different stages of the life cycle into the proper sequence, indicating which environment--ocean or estuary--the fish are in.
2. Other creatures dependent on estuaries.
  - In addition to the English sole there are many other creatures that depend on estuaries at some stage during their life cycle. Discuss the list below.
    - a. Salmon--these fish pass through estuaries on their way to spawn. Young salmon feed in estuaries before migrating into the ocean.

- b. Perch--several species of perch spawn in estuaries.
  - C. Herring enter estuaries to lay their eggs, usually during the month of February.
  - d. Starry flounder spawn in estuaries.
  - e. Waterfowl--see the list of waterfowl that are dependent on estuaries.
3. Have students write a short essay on what they think the best use of estuaries might be. Be sure they understand the need for economic uses as well as fish and wildlife use of estuaries.

## Life Cycle of the English Sole

The English sole is an excellent example of a marine organism which is dependent on estuaries during its life cycle. The eggs are laid at sea during the winter months from November through January and occasionally into the early spring. The eggs drift about in the ocean waters and hatch shortly after spawning. The newly hatched larvae are free swimming and drift about in the ocean waters feeding on plankton. The English sole larvae are almost transparent at this stage. Their eyes are on both sides of the head, but after a few weeks the fish will undergo metamorphosis, as do all of the flounder and soles. The English sole is a member of the right eye flounder family; its left eye migrates over to the right side of the head, the fish becomes flattened, and it lays down on its side. The fish settles to the bottom of the ocean and takes up its bottom-dwelling life style. Pigmentation in the skin of the fish begins at about this time, turning the fish from almost transparent to brown.

Juvenile sole move into estuaries in April to feed and grow in the rich estuarine waters. They stay in the estuaries until October, when they move back into the ocean to spend the rest of their life.

English sole is an important commercial species and is caught by fishermen using nets that drag over the ocean floor. They are sold as fresh fillets.

THE LIFE CYCLE OF THE ENGLISH SOLE

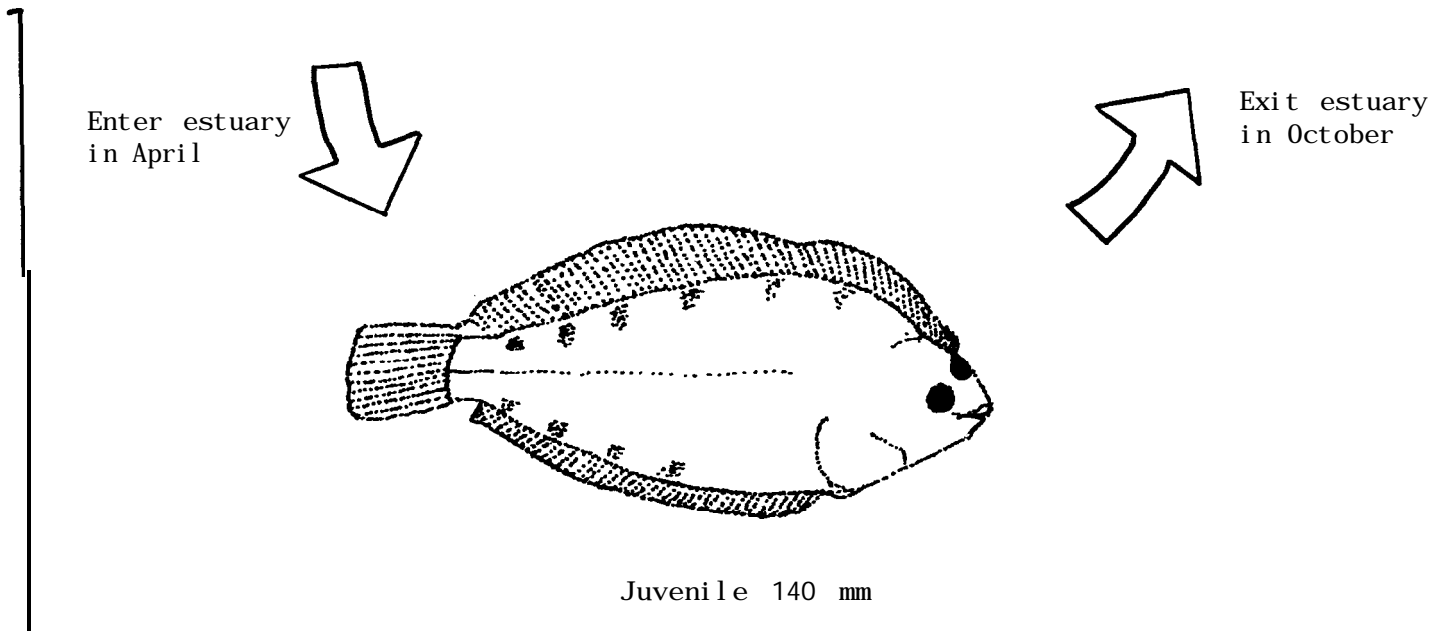
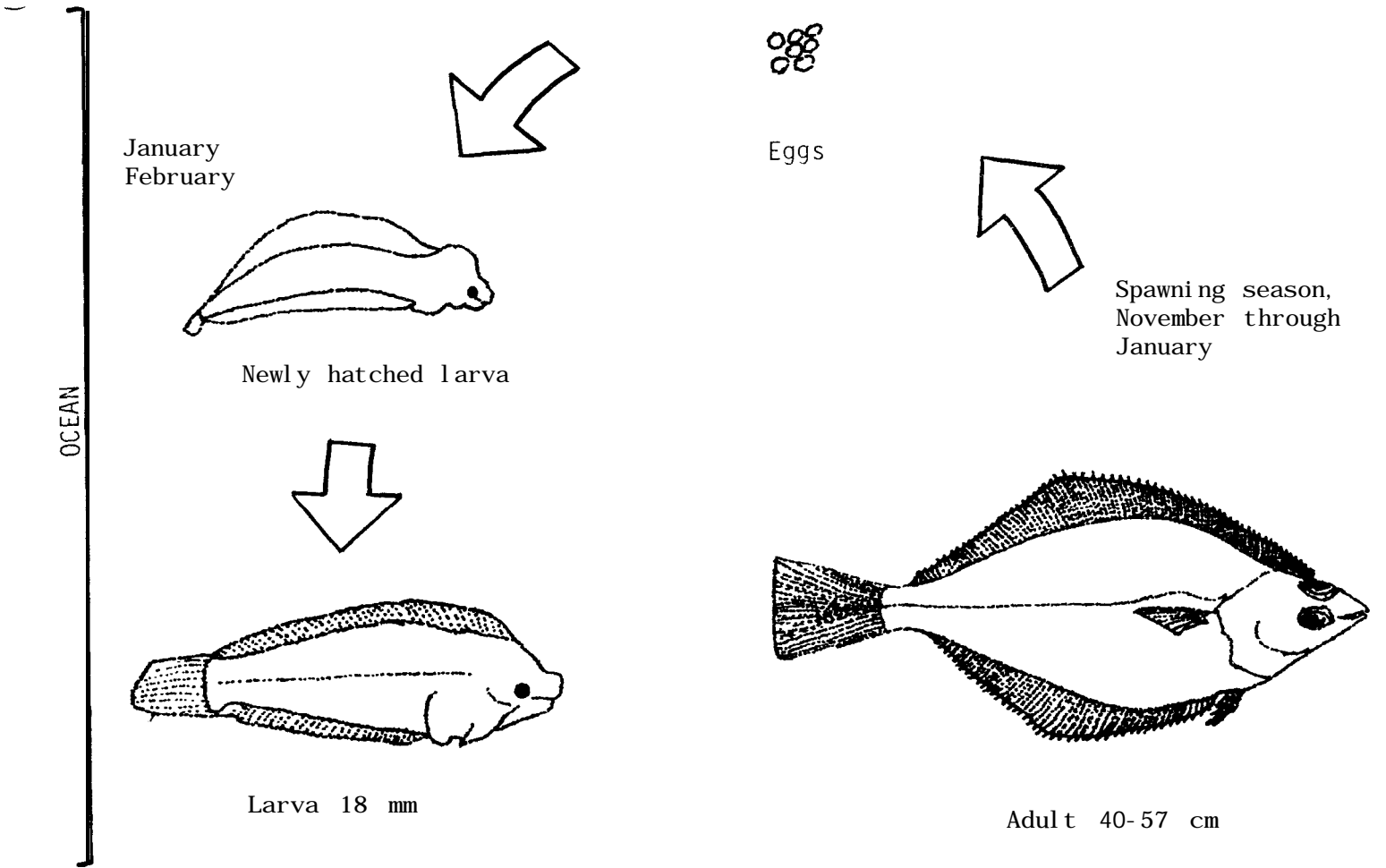

Put these different stages of the English sole into proper sequence, showing the sole's life cycle. Indicate the location of each stage--ocean or estuary.

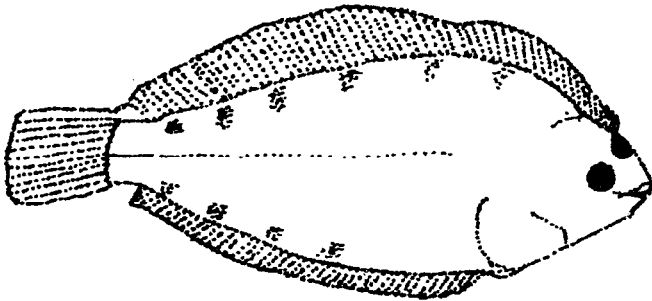
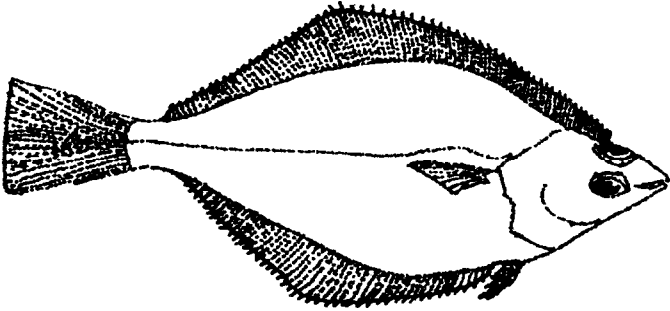





## Birds Dependent on Estuaries

Birds which are totally dependent on estuaries:

brant  
common goldeneye  
whimbrel

Birds almost totally dependent on estuaries:

brown pelican  
great blue heron  
great egret  
canvasback  
greater scaup  
lesser scaup  
buffhead  
white-winged scoter  
surf scoter  
ruddy ducks  
red-breasted merganser  
bald eagle  
semipalmated plover  
lesser golden plover  
black-bellied plover  
willet  
western sandpiper  
least sandpiper  
dunlin  
long-billed dowitcher  
short-billed dowitcher  
marbled godwit  
sanderling  
California gulls  
ring-billed gulls

— ducks

Other birds sometimes found in estuaries:

merlin  
peregrine falcon  
American widgeon  
European widgeon

} — ducks

## **You and Your Harbor**

---

## 16. Field Trip to the Harbor

---

---

### Intent:

A visit to the harbor will enable students to observe firsthand the transfer of cargo, the ships, and the workers on the docks.

### Main Ideas:

1. Harbors are places where ships dock to load and unload their cargo.
2. The docks are busy places where the transfer of cargo takes place.

### Resources:

The Port of Portland offers free guided tours of the Port of Portland facilities.

### Activities:

#### 1. Tour of the port

- Have students note the countries in which the ships are registered. This may be determined by the flags the ships are flying at the stern.
- Note the bow and stern design of the boats from ship design activity.
- Note people at work at the harbor and list their work activities.
- Note the types of equipment used in the transport of articles onto and off ships. Be sure to look for transfer equipment studied in the cargo transfer activities.

#### 2. Follow-up activities to harbor tour

- Develop a mural of the harbor the students visited. Display or list some of the products they saw being loaded and unloaded in the harbor. Indicate where the products were from or destined for.
- Paint a picture of the harbor showing the things the students found most interesting about the harbor.
- Write a poem about the harbor.
- Develop a mural of the harbor showing all uses of the harbor, not only the trade and shipping.

---

## 17. Simulation Game "CARGO"

---

### Intent:

To illustrate the interdependence of Pacific countries, students will buy and sell cargo and travel from port to port in the simulation. This activity involves using data sheets, keeping a diary, and determining latitude and longitude.

### Main Ideas:

1. Trade enables countries to purchase products or materials they cannot produce themselves.
2. Some trade goods may not be vital to a country but may enrich the lives of its citizens.
3. Pacific countries are becoming increasingly interdependent through trade.

### Resources:

1. Sailing projects list
2. Ship's log
3. Import and export commodities list
4. Trading balance chart
5. Map of Pacific trading routes (in the envelope at the back of this book)
6. Exports cost per container chart
7. Appendix of materials for sailing projects

### Activities:

1. Preliminary activities
  - Students need a working knowledge of latitude and longitude. Work through the latitude and longitude activity before starting the game.
2. Simulation game
  - This simulation game involves the buying and selling of commodities commonly traded in countries around the Pacific. Crews of three to four students will have the use of 20 shipping containers and initial capital in the amount of U.S. \$5,000.00 or the local equivalent. The

crews will purchase cargo, travel to selected ports in the Pacific, sell their cargo, and pick up a second load. Travel between ports may be accomplished by completing sailing projects from the project list. As miles are earned, each team may move their markers across the game board. Upon arrival at a port, students may purchase a second cargo and select a port to travel to. Upon reaching a port, students may do a research report on the country or port, the extent of which is to be determined by the teacher.

- When full use is made of the sailing projects, this game can last two or three weeks. However, to familiarize themselves with the game, the students can play it quickly the first time.

Conducting the game:

- Divide the class into crews of three or four students. For each crew, duplicate the Sailing Projects list, the Import and Export Commodities list, the Ship's Log, the Trading Balance Sheet, and the Exports: Cost Per Container sheet.
- Crews plan their first voyage by selecting a starting port and by deciding on the cargo and port of destination.
- Crews purchase their first cargo of 20 containers of commodities, using \$5,000, or the local equivalent. Players should plan on making money conversions only at the beginning or the end of the game, unless a lot of math practice is desired.
- Crews complete the first transaction of purchasing cargo and complete the first Trading Balance Sheet.
- Crews complete their first sailing projects or first round of play from game variation. The sailing projects may be assigned as homework.
- As sailing projects are completed and miles are earned, each team's ship may move across the map to show its progress along the shipping lanes.
- Captains keep a log of the journey across the Pacific by completing the Ship's Log.
- Crews continue sailing projects to move from one port to the next.
- Crews that arrive at trading ports complete the balance sheet to show profit or loss.

- Crews that begin new voyages purchase fresh cargo and complete the purchase section of the balance sheet.
- Crews make presentations of their projects to the class.
- Crews complete voyages by finishing their sailing projects and making final sales.

## Ship's Log

<u>Date</u>	<u>Latitude/ Longitude</u>	<u>Cargo</u>	<u>No. of Days Traveled</u>	<u>Distance to Destination</u>	<u>Remarks</u>
-------------	--------------------------------	--------------	---------------------------------	------------------------------------	----------------

Remarks may be about the destination, profits or losses, sailing projects, crew, and so on.

## Import and Export Commodities

### Australia (Gladstone)

Exports: wheat, wool, meat, bauxite

Imports: cars (20%), electrical goods (30%), tea (10%),  
dairy products (10%), cotton (20%)\*

### Canada (Vancouver)

Exports: lumber, wheat

Imports: cars (30%), electrical goods (20%), copper (10%)

### Chile (Valparaiso)

Exports: copper

Imports: electrical goods (40%), cars (40%), iron and steel  
products (20%)

### Hong Kong

Exports: cotton, rice, tea

Imports: wheat (10%), electrical goods (30%), iron and steel  
products (30%)

### Japan (Yokohama)

Exports: silk, cars, electrical goods

Imports: coal (20%), iron and steel products (20%),  
lumber (20%), wheat (10%), wool (10%)

### New Zealand (Wellington)

Exports: wool, meat, dairy products

Imports: cars (30%), electrical goods (40%), iron and steel  
products (20%), copper (10%), cotton (10%)

\*Figures in parentheses show percentage of profit paid for imports.



Philippines (Manila)

Exports: iron and steel products

Imports: cars (30%), electrical goods (40%), lumber (10%),  
dairy products (20%), rice (10%)

United States (Portland)

Exports: wheat, coal, lumber, iron and steel products

Imports: cars (20%), electrical goods (30%), copper (10%),  
tea (10%), bauxite (20%), silk (20%)

Trading Balance Sheet

Purchased at		Sold at	
<u>Purchases</u>		<u>Sales</u>	
<u>Container</u>	<u>Product</u>	<u>Price</u>	<u>Selling Price</u>
1.			
2.			
3.			
4.			
5.			
6.			
7.			
8.			
9.			
10.			
11.			
12.			
13.			
14.			
15.			
16.			
17.			
18.			
19.			
20.			

Total Cost: \$ A : Total Income \$ B

\*Profit/loss \$ (Subtract A from B to find profit or loss.)

Exports: Cost Per Container

<u>Commodity</u>	<u>Aust.</u> <u>\$</u>	<u>Can.</u> <u>\$</u>	<u>Chile</u> <u>Peso</u>	<u>China</u> <u>Renmi nbi</u>	<u>Japan</u> <u>Yen</u>	<u>N. Z.</u> <u>\$</u>	<u>Phil.</u> <u>Peso</u>	<u>U. S.</u> <u>\$</u>
Wheat	265	265	29,410	571	50,000	380	3,175	200
Wool	265	265	29,410	571	50,000	380	3,175	200
Meat	400	400	44,120	857	75,000	569	4,762	300
Lumber	265	265	29,410	571	50,000	380	3,175	200
Copper	533	533	58,824	1143	100,000	759	6,349	400
Cotton	265	265	29,410	571	50,000	380	3,175	200
Rice	400	400	44,120	857	75,000	569	4,762	300
Tea	533	533	58,824	1,143	100,000	759	6,349	400
Silk	667	667	73,529	1,429	125,000	948	7,937	500
Cars	667	667	73,529	1,429	125,000	948	7,937	500
Electrical goods	933	933	102,941	2,000	175,000	1,328	11,110	700
Dairy produce	400	400	44,120	857	75,000	569	4,762	300
Iron and steel prod.	533	533	58,824	1,143	100,000	759	6,349	400
Coal	400	400	44,120	857	75,000	569	4,762	300
Bauxite	400	400	44,120	857	75,000	569	4,762	300

N. B. Each crew begins with 20 empty containers and U. S. \$5,000. The following chart lists foreign equivalents to \$5,000.

<u>U.S.</u> <u>\$</u>	<u>Aust.</u> <u>\$</u>	<u>Can.</u> <u>\$</u>	<u>Chile</u> <u>Peso</u>	<u>China</u> <u>Renmi nbi</u>	<u>Japan</u> <u>Yen</u>	<u>N. Z.</u> <u>\$</u>	<u>Phil.</u> <u>Peso</u>
5,000	6,666	6,666	735,294	14,285	1,250,000	9,488	79,365

## Sailing Projects

### Miles Earned

- 2,000 1. Learn three major exports and three imports that move in and out of the Columbia River.
- 2,000 2. Prepare at home or in class a **food** common to one of the Pacific countries the crews are planning to visit.
- 1,000 3. Learn the words of a sea chanty.
- 1,000 4. Give the latitude and longitude of Portland, Oregon.
- 2,000 5. Make a coin rubbing from coins of Pacific Basin countries. Compare the value of the coins to U.S. money.
- 2,000 6. Using the encyclopedia, find out the population, size, and climate of three ports in the Pacific (to be selected by your teacher).
- 1,000 7. Solve the following problem: If it is 4,200 miles from Portland to Hiroshima, Japan, and it takes 14 days to reach Japan, how many miles will the ship travel each day?
- 1,000 8. If your ship travels at a speed of 300 miles per day (the average speed of log and cargo ships), how many days will it take to sail from Portland to Auckland, New Zealand (6,000 miles); from Portland to Brisbane, Australia (6,400 miles)?
- 1,000 9. When it is noon Tuesday in Portland, Oregon, it is 5:00 a.m. Wednesday in Japan. You want to place a call from Japan at 10:00 a.m. Tuesday to Portland. What time and what day is it in Portland?
- 1,000 10. A cargo ship uses approximately 2,500 gallons of diesel fuel each day. It costs 70¢ per gallon. How much does it cost to run the ship each day? On a 14-day trip across the Pacific, how much would the fuel cost?
- 1,000 11. Name and describe four crew positions on a ship (see Crewmen's Fact Sheet).
- 2,000 12. Calculate the distance between several ports around the world (to be selected by your teacher).
- 1,000 13. When it is 12:00 noon Thursday in Portland, it is 8:00 a.m. Friday in Auckland, New Zealand. If you wished to call Auckland from Portland at 8:00 a.m. Tuesday, what time and day is it in Auckland?

Miles  
Earned

- 1,000 14. You have \$200 in U.S. currency. You are taking a trip to Japan and must exchange your money for Japanese money (Yen); 250 Y equals U.S. \$1.00. How many Yen will you have?
- 1,000 15. Identify the parts of a ship, for example, the bow, stern, and bridge.
- 2,000 16. Define nautical terms, for example, starboard (right), port (left), and aloft (up).
- 4,000 17. Write an essay about what you think might happen if trade between the U.S. and Japan should suddenly cease.
- 1,000 18. List two countries you think we might trade with should we lose trade with Japan.
- 1,000 19. Learn one custom or greeting from a Pacific Basin country.
- 3,000 20. Refer to the export-import tables and pick the four most important trading nations dealing with the Columbia River ports. Write a report on any one of these countries, including the type of government, capital, climate, population, and language.
- 1,000 21. Make a flag of a Pacific country.
- 2,000 22. Find and make a display of pictures of historic ships.
- 4,000 23. Read a seafaring novel and write a book report on it.
- 2,000 24. Make a scrimshaw item using a bar of soap.
- 3,000 25. Give a report to the class about a famous sailor.
- 3,000 26. Describe the differences between four old sailing vessels: barque, brigantine, schooner, and sloop.
- 3,000 27. Give a report on an occupation in the harbor.
- 4,000 28. Write a report about early transportation on the Columbia River.
- 4,000 29. Prepare a historic display of ships which have used the Columbia River.
- 3,000 30. Do soap carvings of ships or other nautical items.

## **Part Two: Readings**

The Captain Comes into Port

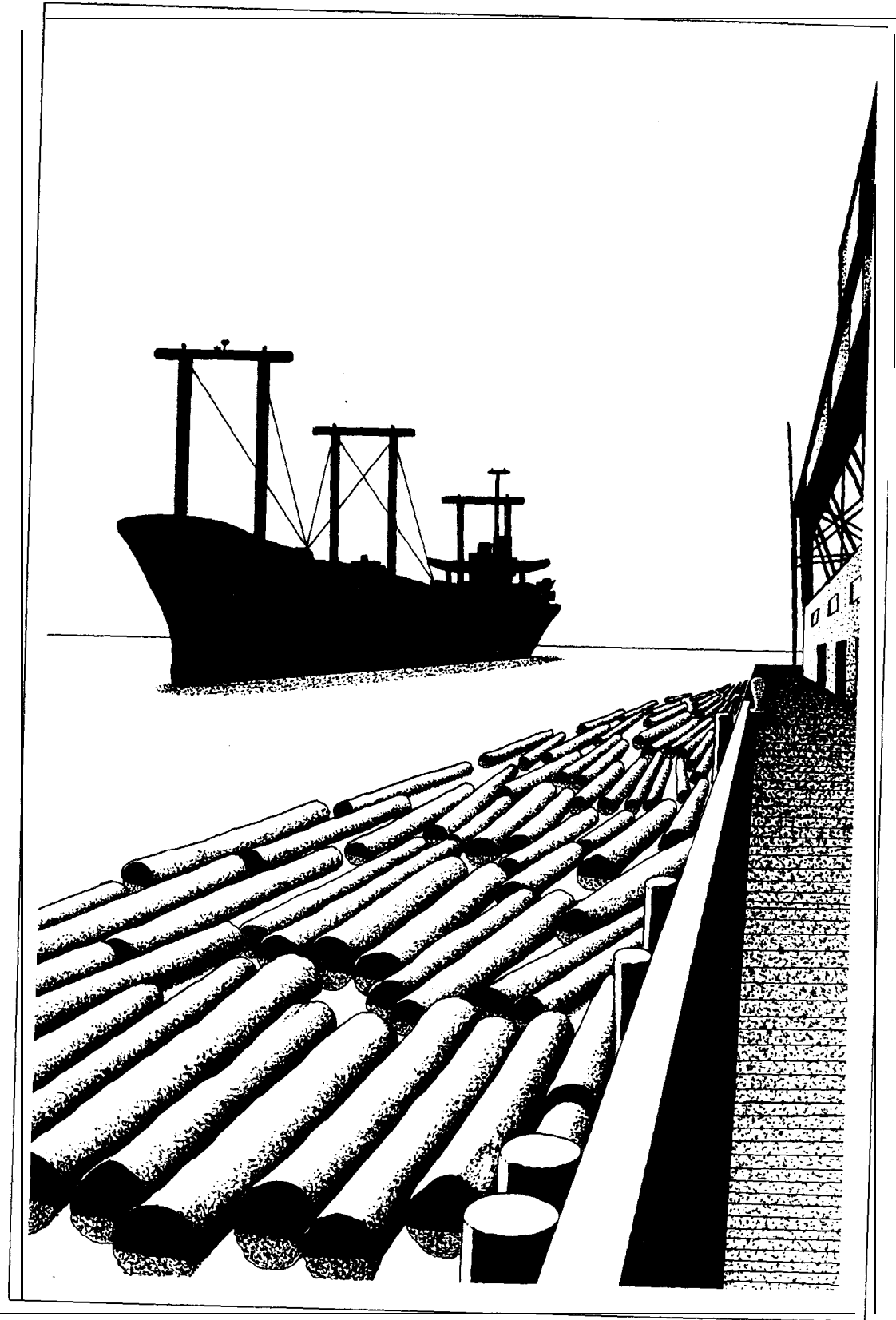

## The Captain Comes into Port

Captain Jumpei Ito, on the bridge of the log ship the Seiko Maru, watches the Pacific waters ahead for a glimpse of the light from Buoy CR. For six years he has been a shipmaster. During that time Captain Ito has made many crossings from Japan to "take on logs" in this closest of United States ports, Astoria, Oregon.

Now his ship is almost two weeks out of Japan and about eight miles from the mouth of the Columbia River. The ship is rolling in the ocean waves. The automatic steering device has been turned off and the quartermaster is reading the instrument panel. The ship is now approaching one of the buoys that marks the entrance to the harbor.

The quartermaster had talked with the office of the Columbia River Bar Pilots by radio more than sixteen hours earlier. He was given the buoy location and his likely arrival time. Now Captain Ito can see the buoy light. The quartermaster says that the moving dot near it on the radar is the pilot boat waiting to meet them.

The bar pilot will come aboard the ship to guide it across the often-dangerous Columbia River. Captain Ito has heard many stories of shipwrecks of earlier centuries which gave the mouth and bar of the Columbia their name-- "Graveyard of the Pacific." Captain Ito is glad to be shipmaster in an age of modern navigational equipment and well-trained pilots.



The bar, an underwater bank of sand, is located at the mouth of the harbor. The bar is built when the river current meets the ocean tides. The sand, which has been carried downstream hundreds of miles, is finally deposited. This piece of rising ground makes the water shallow and difficult to navigate. During low tides and stormy weather, the bar is especially dangerous. However, only once in his trips to Astoria did Captain Ito and his ship have to wait outside the mouth of the Columbia for any length of time. After a fierce winter storm and waves of 20 to 30 feet, the bar may be so rough that the Coast Guard has to close it to all ships.

It is still dark when the bar pilot comes aboard, using a rope ladder lowered against the hull of the ship. The captain and quartermaster give the bar pilot information about the weight of the cargo and the draft of the ship. The draft is the depth of the water that the ship displaces. The three men also discuss any steering problems and whether all instruments are working properly. Captain Ito is still in command, but now the safety of the ship and all aboard it are in the pilot's hands.

There is an increase in the waves; the Seiko Maru begins pitching as they head across the bar. Captain Ito has entered the Columbia in all kinds of weather. He has gone through fog banks so thick that radar was used continuously. He has been in hard rains which kicked up such a chop that it was difficult to tell buoy lights from

lights along the shore. Captain Ito has seen the tug-of-war between the ocean and the river make the bar crossing much more of a challenge for the pilot than it is on this particular night.

The Seiko Maru leaves the jetties behind and continues the twelve miles upriver towards the Astoria docks. There is some thin, patchy, October fog, but Captain Ito knows what land lies portside, across the darkness of the Columbia River. The rocky, black headland is Cape Disappointment in Washington State. Further on, and still to the left, they pass Sand Island and the other sands at the entrance to Baker Bay.

Fog drifts by and light begins to show as the sun comes up. They pass Clatsop Spit, then Youngs Bay. It is now about two hours since they left the buoy. The orange glow of sunrise is spreading above the trees which frame Astoria. Captain Ito finds this port town of steep hills, dotted with old, wood-framed houses, and thick with trees, almost like a park. One could squeeze it into a tiny section of his home port--huge, bustling Tokyo, Japan.

The bar pilots' office has notified the tugboat pilots of the Seiko Maru's arrival time. Two tugs, the Sarah Brix and the Betsy L, are waiting to guide the ship into its berth. At the Port of Astoria docks there are berths for three large ships. Two ships are docked there already.

The tugs, one pushing on the stern and one on the bow, nudge the Seiko Maru toward the slips, or areas of water

between the piers. The tide is ebbing, so with the strong river current flowing out toward the mouth, it takes a little longer than the usual half hour for the tugs to get the ship into its berth. However, the Astoria docks are located and protected in such a way as to be calm and stable.

Soon after the ship is tied up, the longshoremen begin their day's work. Captain Ito knows from past experience that the longshoremen on the Astoria docks work as hard and as quickly as those in any United States port. Captain Ito expects that the Seiko Maru will be loaded with logs and ready to leave port in less than a week.

Today, a barge or log raft is expected to arrive from upriver Lewiston, Idaho, with a load of pine logs. Trucks from local lumber companies will also arrive with logs. These log bundles will be separated by the longshoremen. Three giant cranes on the Seiko Maru will be kept busy lifting the logs onto the ship, from the log raft in the water and from the trucks. The Seiko Maru can hold between two and three million scribner feet of logs. Scribner is the way logs are usually measured for export.

While in port, Captain Ito and his 27-man crew will be busy. The captain will look out for the general welfare of the ship. Directing the loading will be the job of the first mate. The Port of Astoria will see that the ship is resupplied with water, and an oil tanker will pull alongside to refuel the ship.

Before he leaves Astoria, Captain Ito hopes to visit the new Columbia Maritime Museum on Astoria's waterfront. He has seen the outside of the lovely wooden building. The sweep of the roof reminds Captain Ito of the rise and fall of the ocean waves that will take him and the Seiko Maru back to Japan.

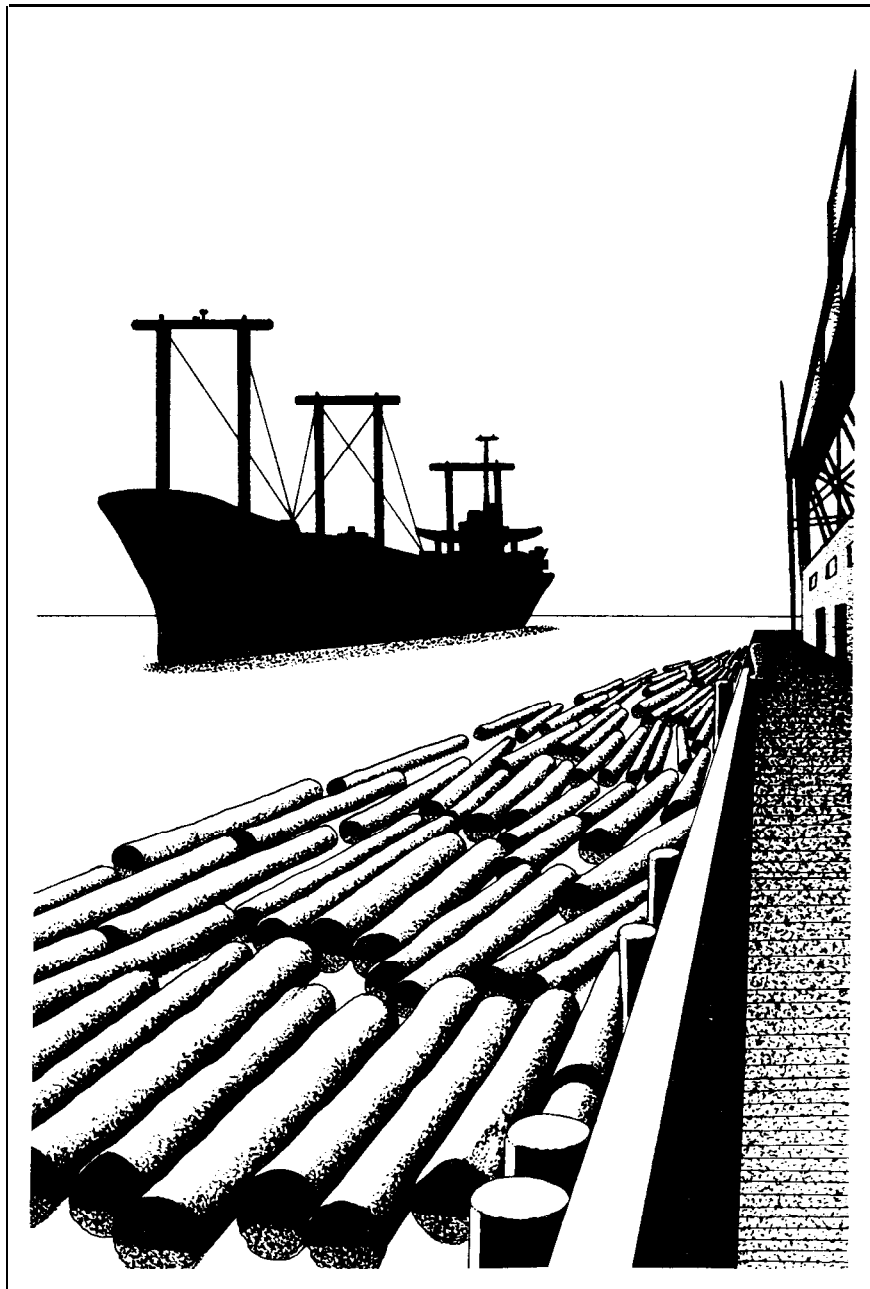

Bringing Ships into Port: the Life of a Bar Pilot

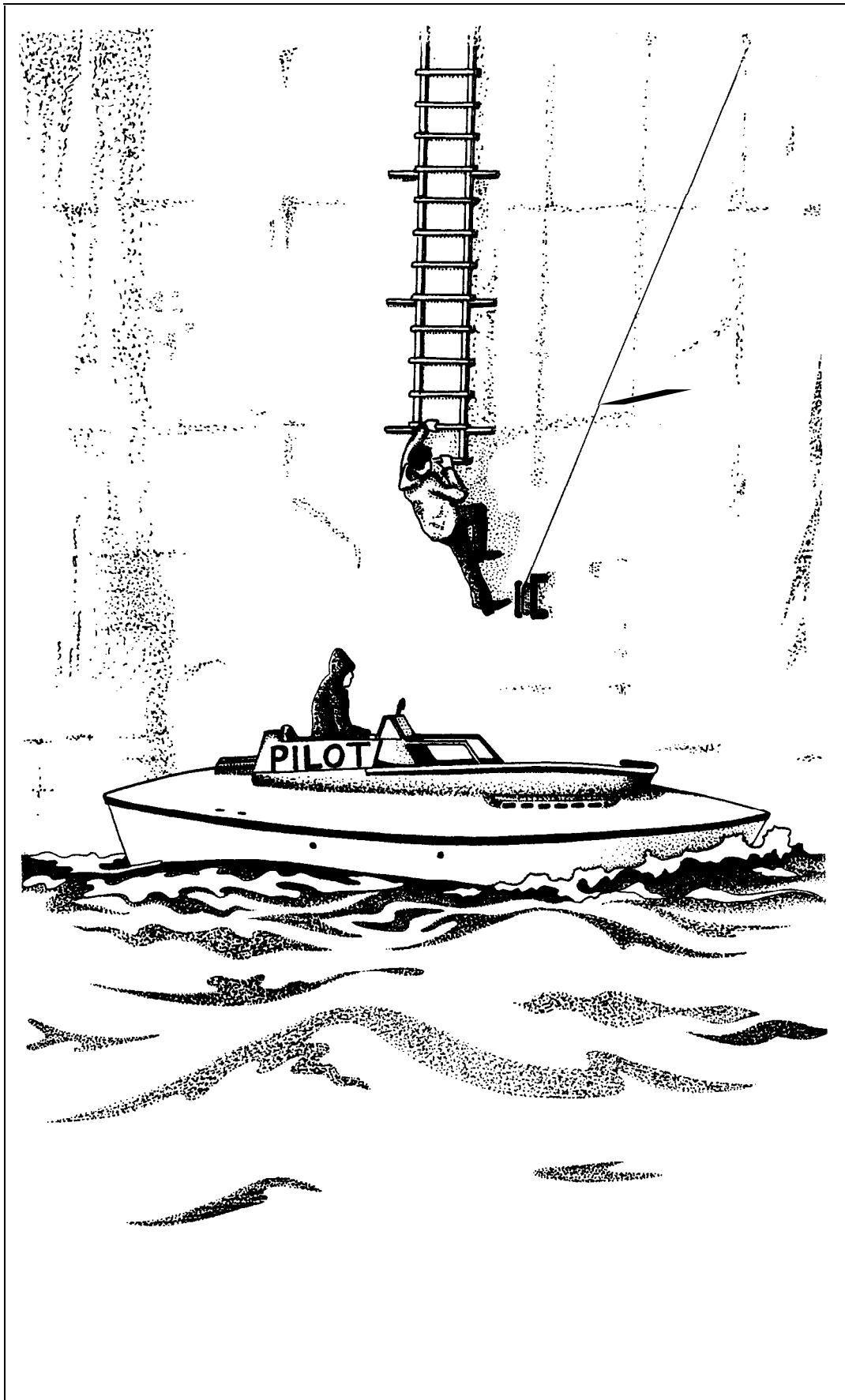

## Bringing Ships into Port: The Life of a Bar Pilot

"When a ship is rolling to 45°, chairs are flying, people are falling down and the rail is under water, you know you're in trouble," said Captain West. "That's when a pilot tries to stay totally calm."

Captain West was talking to a class of ten-year-old students about his job as a Columbia River bar pilot. Fortunately, the situation he was describing almost never happens. But this particular experience took place a few years ago when Captain West was piloting a new, fast ship from India across the Columbia River bar.

Captain West continued his story. "When the ship first started rolling hard, I had given orders for the engine to be slowed. The Indian captain said the ship was not carrying grain, but SOMETHING was moving inside. Every time the ship rolled, it went a little further. We were in danger of rolling over! The captain and crew were getting very excited by this time. The captain sent several officers below to bring the wives and children up on the bridge and get them into life preservers. We reached a really large roll--a disaster. I gave orders to speed up. Only then did I discover that the engines had stopped because of the rolling of the ship. The engines restarted, and at last we made it safely across the bar. However, the ship was tilted over in the water because of the cargo shifting. This caused us to wait for the tide to come in

before we could go the rest of the way to Astoria."

A girl wearing a bright green sweater raised her hand and asked, "Why did you want the engine slowed down and then speeded up?"

"Well, you see," explained Captain West, "a ship is rolling and moving with the waves. The waves are also moving up and down. If the ship rolls at the same time it hits a wave, the roll gets worse. Think of it as a swing going higher each time it is pushed. Slowing down the ship is usually the easiest way to change this. It took a very long time in this case." He smiled.

"What was the ship carrying?" asked the girl in green.

"Containers of tea," answered Captain West.

The captain bent over and rolled a pant leg to his knee. He showed the class the red rope burns and the brown scars on his leg.

"This is what I call bar pilot's shin," he said. "The distance between the scars is the same as the distance between the steps on a ship's ladder. The greatest danger to bar pilots is in getting on and off a rope ladder on the open sea. This is especially true when there are high seas or storms. Over fifteen years ago, when I came to Astoria, a bar pilot's job was even more dangerous. Pilots came to the ships in small, open, round-bottomed boats that flooded easily: pilots and crew were sometimes lost. However, the Columbia River had a new 87-foot boat built, copied after a German rescue boat. It carries a small transfer boat which

is also very seaworthy. Since then, only one man has been lost--a pilot who fell from the ladder and drowned about eight years ago."

"Are there any other dangers?" asked a red-haired boy sitting in the back of the room.

"Darkness," answered Captain West. "About 75 percent of our work is done at night. Most of the ships entering the Columbia go beyond Astoria to Portland. That is about eight hours farther upriver. It is best to have longshoremen load and unload ships during the day: ships try to reach Portland by 8:00 a.m., and when they leave, do so about 5:00 or 6:00 p.m. That puts them at our bar during the night. Radar helps us work through fog; that couldn't be done before. We used to whistle signals when approaching the Astoria pilot station. Some people miss that. But now, we can talk by radio, which makes meeting and passing ships in close quarters much safer."

Captain West walked over to the blackboard and pointed to a chart he had taped there.

"Even though the night bar crossings are done mostly by 'feel' and with radar, I had to learn every inch of this chart of the Columbia River and reproduce it, exactly, in order to get my pilot's license. You can see these lines and dots and numbers on the chart. These represent lights, buoys, heights, depth of water, colors, and coordinates, all of which I learned."

A girl wearing a blue dress and blue hair ribbons asked Captain West, "How did you decide to be a bar pilot?"



"I grew up on the Oregon coast, near Coos Bay," answered the captain. "As a boy, I delivered newspapers aboard all kinds of boats docked there. When I was still in high school, I got a job as a deck hand on a Corps of Engineers dredge. I was in the Merchant Marines during World War II, and I stayed at sea when the war ended. Before coming to Astoria, I was a shipmaster, or captain. The rule for Columbia River bar pilots is at least two years of experience as a shipmaster. In some parts of the United States there is a system where you are taught piloting by a sea or bar pilot. A pilot's license requires 40 crossings of the bar. The state of Oregon requires 100 or more round-trips, with a licensed pilot with you."

Captain West continued by telling the students some of the history of piloting. Bar pilots are called "sea pilots" in most places, because the harbors don't have bars. Bays and harbors which have bars are those on large rivers. He told them about an 11th-century law, back in the days of pirates, which said that if a pilot wrecked a ship and could not pay for the damages, he was to lose his head. He talked about the one-eyed Clatsop Indian, Chief Concomly, who was the first river pilot on the Columbia River. That was in the early 1800s, when fur trading was important. A famous and daring bar pilot he mentioned was Captain Flavel; he built a mansion in Astoria which is now used as a historical society museum.

"What kinds of ships do you pilot?" asked a boy sitting in the front row.

Captain West replied, "All kinds. About 2,000 ships come across the bar each year, carrying more than 20 million tons of cargo. I didn't pilot them all; there are twenty Columbia River bar pilots and about forty river pilots. We pilot bulk carriers, loaded with grain or wood chips, oil and chemical tankers, log ships, and general cargo and container ships, bringing automobiles, stereos, microwave ovens, and other goods from Japan and take fruit and coal back to Japan or Korea."

A small girl, with brown curls, asked shyly, "How much money do you make?"

Captain West laughed. "Almost every time I talk to a school group, someone asks that question. We are very well paid for a dangerous and responsible job. We earn about the same amount of money as doctors."

When Captain West left the school, he drove up the hill toward his large, wood-framed house overlooking Astoria's harbor. He passed and waved to several friends. Knowing people and having them know you was one of the things he had always liked about living in a small town like Astoria.

A Day in the Life of a Tugboat Captain

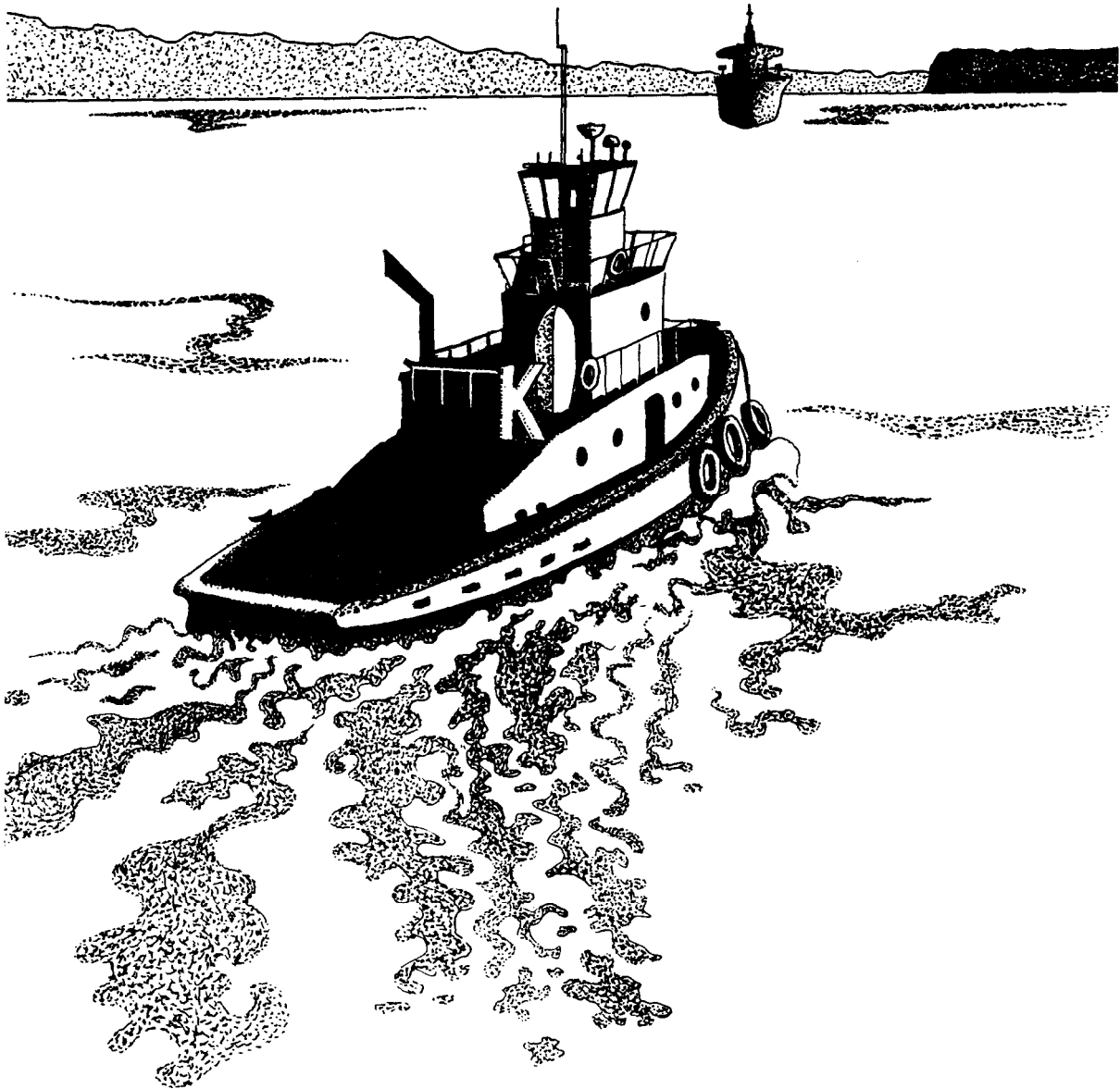

## A Day in the Life of a Tugboat Captain

Ken Haglund steps out of the towboat company office, strolls across the dock, and climbs aboard the tugboat, Betsy L. He checks the instrument panel of the boat and starts the twin engines. He signals to his deck hand, Dave, who loosens the mooring of the vessel, and the Betsy L slowly begins to pull away from the dock. The Seiko Maru, a log ship from Japan, had radioed the bar pilot's office the day before and requested two tugs to assist the ship into dock at the Port of Astoria. The vessel is expected at 9:30 that morning, and in a busy waterway like the Columbia River is is very important that the tugs be there on time.

The first order of business that morning is to check the currents. Letting the engines idle, Captain Haglund lets the tug drift with the current to check the speed and direction of the drift and also the wind velocity. Current and wind must be considered when bringing a ship into dock. The ebbing and flowing of the tides can be especially troublesome on the Columbia when combined with the currents of the river. Satisfied with his current check, the captain pushes the lever forward and heads the tug for its meeting point with the log ship.

There are white caps on the river. Another Pacific storm has just passed through and the water is still choppy from the storm. The log ship has been delayed eight hours because of the storm. The ebb tide, combined with the

20-foot waves, had closed the bar to all ships entering or leaving the harbor. Now, at high tide, the waves are still big but calmed enough by the high tide to allow the ship to enter.

Reaching the destination only one-fourth mile from Pier Number 2, Captain Haglund again idles the motor and waits for the log ship, already looming into view. As the log ship comes within range, the two tugs begin to move into position. The Betsy L, the more powerful of the two, moves to the bow of the ship while the Sarah Brix moves to the stern. Captain Martin West, a Columbia River bar pilot, is in command of the log ship and it is he who has brought the ship from just outside the mouth of the harbor across the bar into the river. It is his responsibility to see the ship safely into its dock. Captain West has decided where the two tugs will work and will be directing the tugs' operation until the ship is docked. Captain Haglund eases his tug against the bow of the Seiko Maru. With a 2,000-horsepower tug under his command, he plans each move carefully. The 85-foot tug is dwarfed by the towering ship. Captain Haglund can see nothing but the wall of metal against which his tug must push and pull until the ship is safely into dock. Towering 20 feet above his head is the deck of the Seiko Maru. Dave casts the head line to the ship. The three-fourth-inch steel cable will attach the tug to the log ship until it is secured and safely docked.

Static from the radio is broken by Captain West's

voice. He gives directions to the tugs. Captain Haglund repeats the orders and eases the heavy rubber fender of the tug against the log ship and begins to push against it. Slowly, the ship turns in the direction of the dock. Instructions are given again by Captain West. He is the only one with a clear view of the river and the dock.

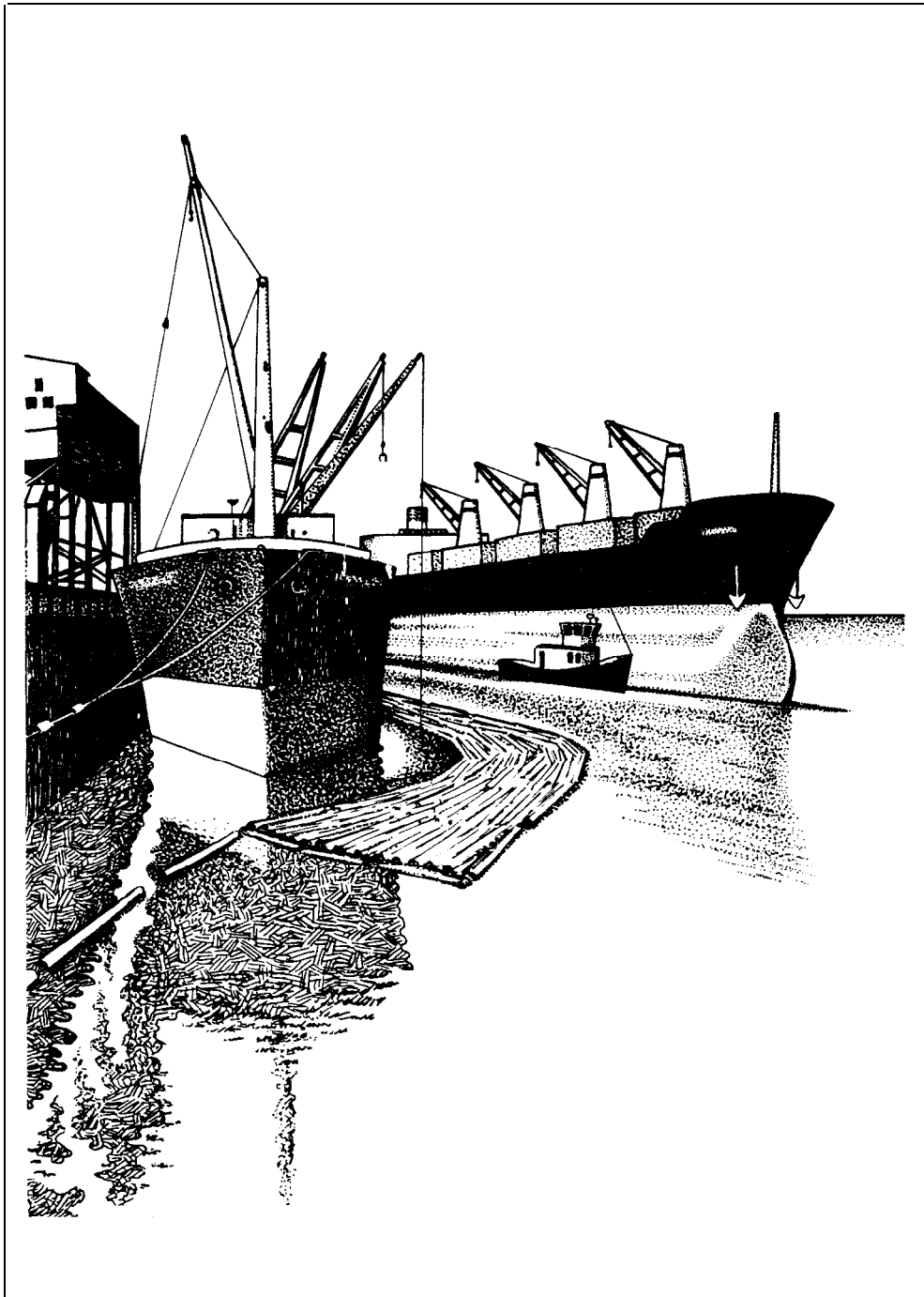

Through the use of the two tugs and its own engines and rudder, this huge log ship is slowly moved into the dock. Tied securely in place, the ship will begin to take on its load.

Backing his tug away from the Seiko Maru, Captain Haglund turns the tug upriver. Only one hour has elapsed since tying on the first head line. A busy day still lies ahead of him and the Betsy L. A barge of fuel oil is waiting and the Betsy L will tow it to a waiting Korean container ship. Once the Korean vessel has taken on fuel oil, it will continue its journey on up the river to Portland, Oregon, 110 miles inland. Also anchored in the river is a Panamanian tanker loaded with diesel fuel and a Russian grain ship. A Japanese ship loaded with cars is disappearing from view up the river on its way to Portland to unload. Passing to his left, an ocean-going tug and barge are heading for the bar and the ocean beyond. Their destination is Alaska or Hawaii with a load of manufactured goods for our two most isolated states.

The Korean ship thus loaded with fuel, Haglund turns the tug back towards his home dock, where she will be tied up for the night. If there were night work to do, a second crew would be on hand to work the tug through the night. Ships enter the Columbia during the night as well as the day.

The rain that had pelted down during the day was finally ceasing as Captain Haglund left his tug.

Cradle of Life--the Columbia River Estuary

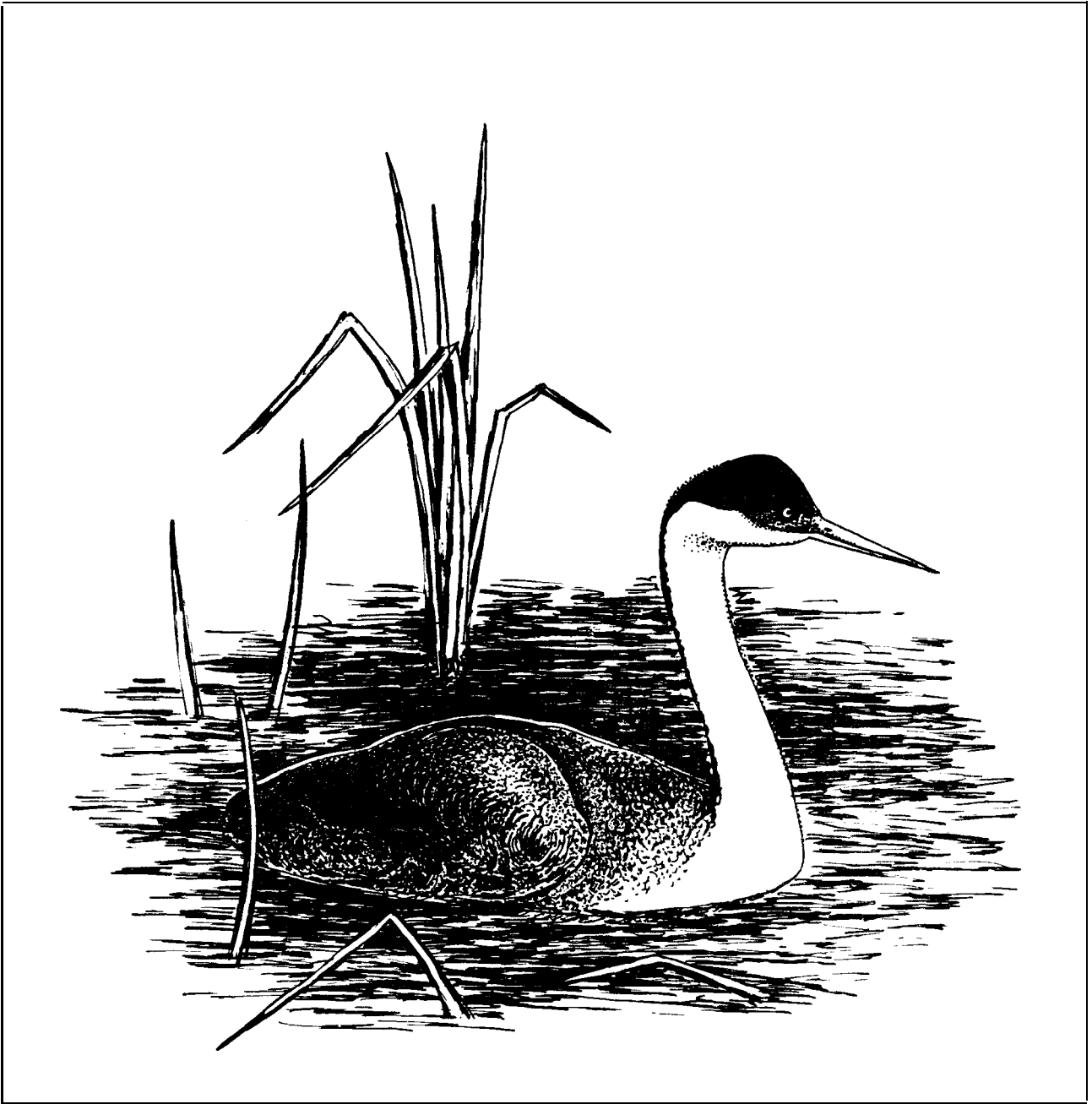



## Cradle of Life--the Columbia River Estuary

As the forty-foot boat pulled away from the dock at Hammond, Oregon, the April air felt cold and damp to those on board. George Campbell and Dan Murphy, biologists with the National Marine Fisheries Service, and four young future biologists were headed for a tour of the lower Columbia River estuary. George cut the power of the engine to a steady "purr" so he could be heard.

"You may already know that an estuary is a river valley which has been invaded by the sea. Twice each day the tides come into the river. The salt water mixes with the fresh river water. This mixed, brackish water can be found at least 20 miles from the river's mouth. One of the unique things about this estuary is the tremendous amount of fresh water flowing into it. After all, the Columbia is the largest river on the West Coast. This mix of salt and fresh water affects the fish and other organisms and controls where they can live in the estuary."

Dan, who had been looking through binoculars, pointed toward the marshlands hugging the shore along Trestle Bay and Clatsop Spit.

"Many of the waterfowl who spend the winter on the estuary have migrated north," he said, "but if you use your binoculars I think you'll see several grebe that are still here. They sit lower in the water than ducks and sink like a submarine when they sense danger. They are great

underwater swimmers and fishermen. They also have a strange habit of swallowing feathers, perhaps to line and protect their stomachs from sharp fish bones. The plants in this marsh are mostly hollow-stemmed rushes and reeds or sedges with sharp, triangular leaves. Behind the bay, on the sandy dunes, you'll see Scotch broom and small, twisted coast pine."

George turned the boat and moved out across the estuary toward Sand Island and Baker Bay. George pointed to the right, to an area of shallows called Desdemona Sands. "For 18 months Dan and I have been studying the fish population here and in other parts of the estuary, obtaining samples from 63 different sites. We wanted to find out what fish live in this estuary, why they live where they do, which fish move in and out, what they feed on, and who their predators are."

"Two predators you'll find in the Desdemona Sands area and near the river mouth are seals and sea lions," added Dan. "Fishermen think they eat too many salmon." "Yes" George agreed. "Since a law was passed in 1972 protecting seals and sea lions, they have become very common in the river. We know they eat a variety of fish, including salmon. When the salmon enter the river on their way to spawn, the seals are usually in the river."

Dan nodded. "The biggest problem occurs when the fishermen set their nets to catch the salmon. Some of the seals learn to take the fish from the nets. There are some

pretty frustrated fishermen when they pull in their nets only to find half-eaten fish for their catch. And that's just one problem we have with salmon on the Columbia. In recent years the salmon have been slowly disappearing. There are many reasons for this: overfishing, dams built upstream without fish ladders, erosion caused by logging, irrigation systems for farming, pollutants from industry, and loss of habitat and food sources. If we hadn't built hatcheries and set fishing seasons and limits on numbers of fish that can be taken, there would be very few salmon left."

"Not only is the salmon important, but mysterious as well," said George. "No one knows for sure how a salmon, born in a redd or gravel nest on a stream bottom, finds its way to the ocean, only to return two to five years later as an adult and fight its way upstream to its birthplace to spawn. Some biologists think it is due to an extremely well-developed sense of smell."

"Yes" George agreed, "but in addition to its important runs of salmon, the estuary is a fine nursery for juvenile fish. Some species are born here or in neighboring rivers and grow in the estuary. In our sampling we have found 95 different species of fish. Some of the most common are bottom fish such as starry flounder, staghorn sculpin, and Pacific tomcod, and, higher in the water column, such fish as longfin smelt, northern anchovy, Pacific herring, and shad."

Dan added, "To catch our samples, we use trawl nets with tickle-chains for kicking up bottom fish, purse seines, and fish traps. We also use beach seines, but without the horses."

George and Dan laughed at the surprised faces of their young guests. Dan pointed toward the sand spit they were approaching. "Sand Island was a favorite beach seining ground back in the early 1900s. A boat would lay out a huge net with one end fastened to land. After making a long loop the boat would return to shallow water. Horses were then attached to the net to drag it in. The horses lived on the island in barns set up on pilings."

The boat was close enough to the spit for those on board to see a flock of sandpipers and hear their high-pitched peeps. The sandpipers bobbed up and down as they fed, scurried ahead, and then turned as one bird and scurried back the way they had come.

Dan pointed to the left and the rocks near Cape Disappointment. "We may see some of the large, black, blue-throated Brandt or the red-faced pelagic cormorants who nest here. These birds fish in groups, fly close to the water as they chase down fish, and dive, usually from a sitting position, to scoop up bottom fish."

The boat left Baker Bay behind in a shower of spray and headed toward Youngs Bay. Glaucous-winged gulls, those silvery-grey garbage collectors of the estuary, were calling and gliding above. Smaller, black-capped Caspian terns

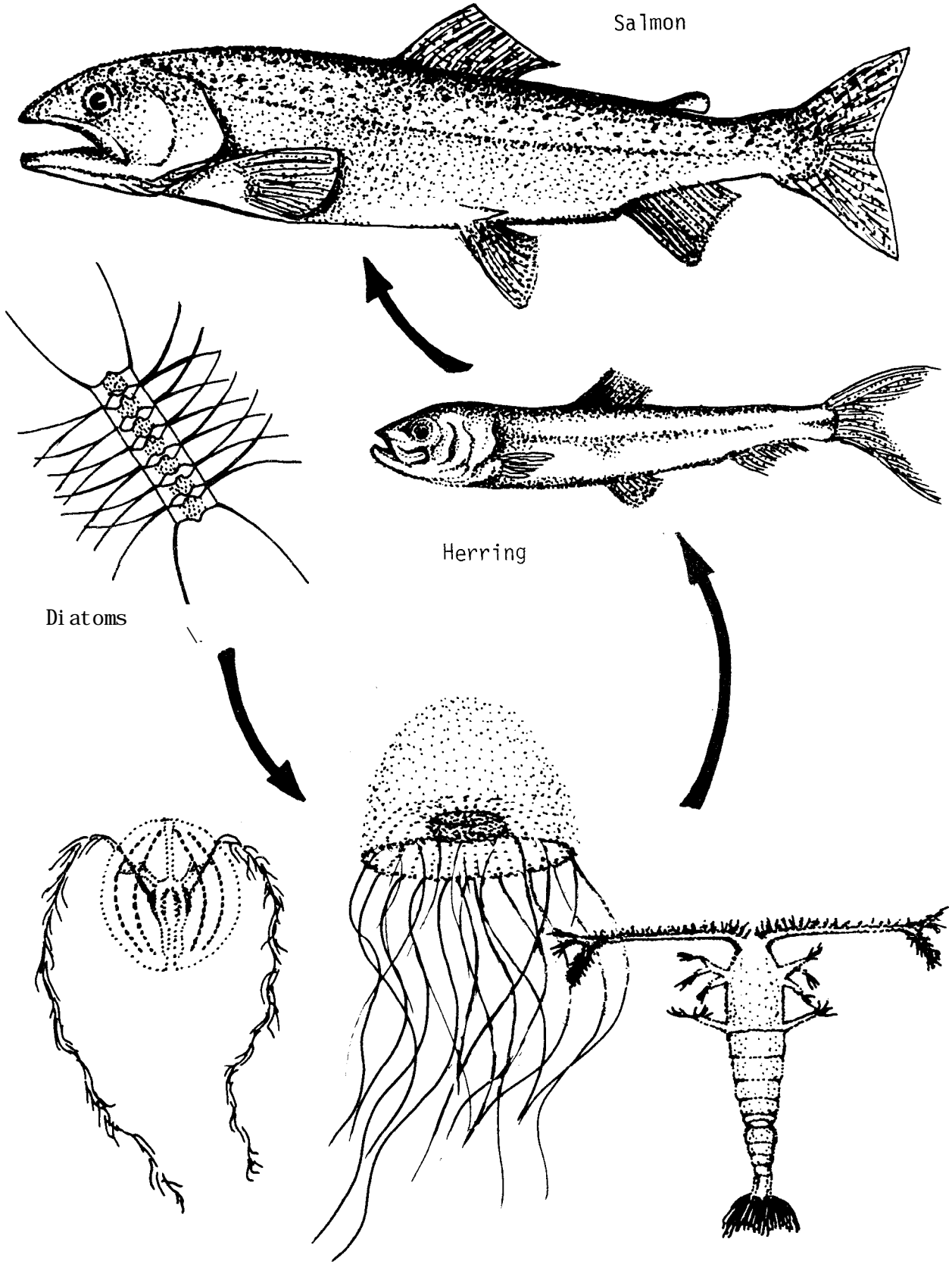

Salmon

Herring

Diatoms

Zooplankton

flashed their wings and forked tails as they plunged just below the water's surface, then flew high, swallowing their fish.

George shouted over the roar of the boat's engine, "We haven't mentioned the most numerous form of life in the estuary--the plankton. These are the floating or drifting plants and animals such as the microscopic diatoms and copepods. Along with bottom dwellers and insects on the water, plankton provide much food for juvenile fish in the estuary. Herring swim through the water with open mouths, straining plankton into their throats through gill rakers. Many anchovy, smelt, and sand shrimp are eaten by larger juveniles. And higher up on the food chain, flounder and sculpin feed on small fish. Pacific lamprey parasitize both juvenile and adult salmon, and sturgeon feast on small fish."

George slowed the boat as it entered the Columbia estuary and moved toward the marshlands bordered with brown-spiked cattails, lady ferns, and yellow-flowering skunk cabbages.

"You'll notice a great many mallard ducks in the bay," said Dan. "They are the most commonly seen waterfowl that live year-round on the estuary. The males have green heads and the females are brownstreaked. When they feed on underwater plants, they 'dabble,' or paddle with their webbed feet, keeping their heads down and tails up.

"Sometimes wading birds like the great blue heron have been seen in Youngs Bay, stabbing at fish or frogs with

their long necks and bills. They are more often seen in the upper estuary where they nest in colonies called rookeries."

"Furbearers such as beaver, river otter, muskrat, and especially raccoon have been seen here, as well as near other estuary marshes," added George.

"This estuary is teeming with life, from the microscopic plankton, to small fish, to large fish like the salmon, to mammals such as seals and sea lions. Every few years we even see an orca, or killer whale, who comes in from the sea to feed on the seals."

A brown, owl-faced marsh hawk glided overhead on long, heavy-moving wings. All eyes watched it sink and rise above the willow and crabapple trees near the shore, as George headed the boat back to the Hammond dock.

The Fish and Wildlife of the Columbia River





The Fish and Wildlife of the Columbia River

GREAT BLUE HERON (Ardea herodias)



On a calm day, great blue herons may be spaced like posts across the shallows of bays, estuaries, and rivers. Watchers notice that the posts move, but ever so slowly; and patient watchers are rewarded by seeing the spear-shaped bills in action. Each blue-gray adult has its own fishing territory, whereas juveniles are more apt to gather in clusters and less apt to catch fish. Great blue herons build bulky stick nests high in the same grove of trees year after year. Eventually the trees become smothered by guano--the birds' waste--and, dying, fall over.

WESTERN GREBE (Aechmophorus occidentalis)

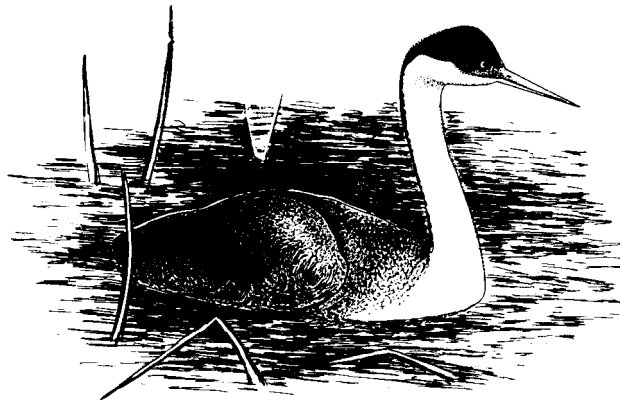

Western grebes once were called swan grebes because of their long, graceful necks. These red-eyed, two-toned birds--sooty on top, white on the bottom--gather along coastlines by the hundreds to winter. Come spring, they retire inland to breed on ponds, where their courtship dance is famous for its sprints atop the water. These fish eaters sink and return to the surface in a magical fashion. The sight has been well described by Aldo Leopold, who buried himself neck deep in a muskrat house to witness it: "I was starting to doze in the sun when there emerged from the open pool a wild red eye, glaring from the head of a bird. Finding all quiet, the silver body emerged: big as a goose, with the lines of a slim torpedo."

BRANDT'S CORMORANT  
(Phalacrocorax penicillatus)

Brant's cormorants are easily identified coastal residents as they fly in a long black file from roost to fishing grounds. While feeding underwater, these yard-long birds pack several fish into their expandable gullet, which has given them a reputation for gluttony. Afterward, they may retire to protected rocks and stand with wings extended in the sun, drying their feathers. Brant's cormorants have blue throats bordered by dirty-yellow feathers; our other two kinds of cormorants have orange or red throats and cheeks.



WESTERN SANDPIPER (Calidris mauri)

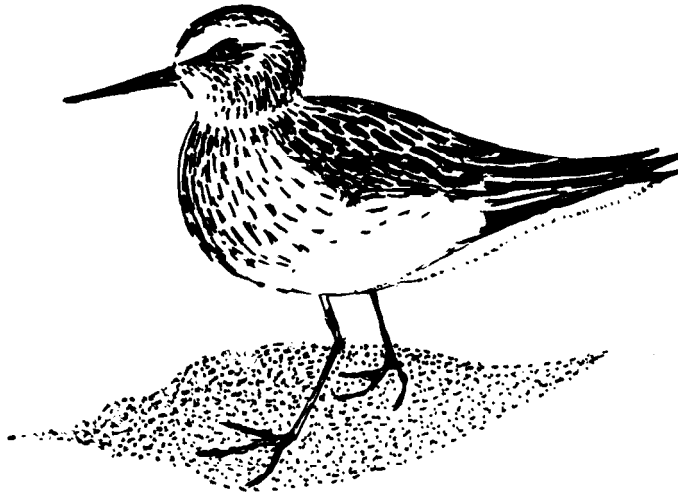

A great wave of western sandpipers moves north along the Oregon coast in May. After breeding in Alaska, these beach-loving birds return to Oregon for the late summer, and a few stay all winter. Flocks of sandpipers are a delight to watch as they scamper in and out with the waves or fly up and down the beach, their white bellies flashing in unison as they veer. These little "peeps" closely resemble other kinds of sandpipers, but a sharp-eyed watcher may notice that the tip of a Western sandpiper's bill droops.

WHITE-WINGED SCOTER (Melanitta fusca)

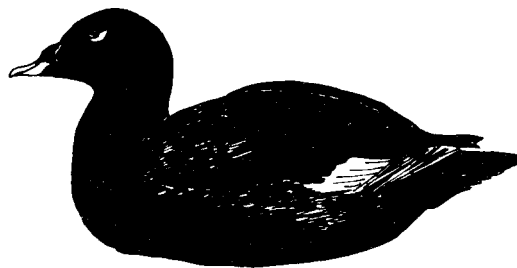

Black ducks bobbing near shore are apt to be white-winged scoters. When they fly, the white wing patches confirm their identity. These clunky-looking ducks prove wonderfully skillful in the roughest surf, where they dive unharmed in and out of waves. They eat shellfish and are capable of swallowing a big oyster--shell and all.

BRANT (Branta bernicula)

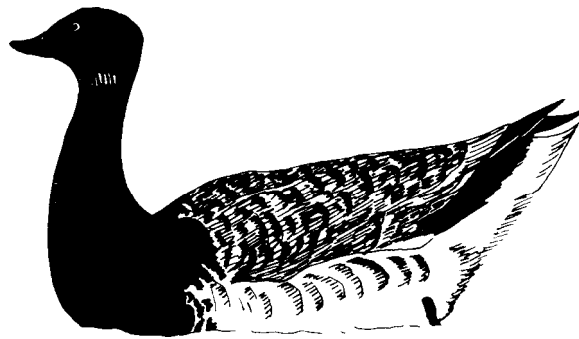

Brant are sea geese that breed near the northernmost fringes of North America, then fly south to winter along the Pacific and Atlantic seaboard. Only two feet long, these black-headed, brown-backed geese are especially fond of eelgrass. Indeed, perhaps they are too fond of it--in the 1940s, when eelgrass beds died from diseases on the Atlantic coast, the brant population crashed. In the West, hunting also takes a heavy toll on these geese, especially in California.

COMMON LOON (Gavia immer)

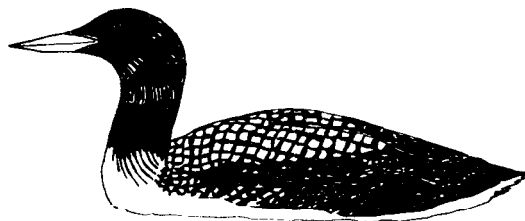

Common loons breed on inland ponds, preferring remote waters of the high country where their wild yodel knifes through the nights like a message from another century. In the fall they give up fresh water for salt water. At the same time their greenish head and black-checked back become mousy colored. These divers use their short wings to perform swimming maneuvers in pursuing fish. They have been known to stay underwater for 15 minutes and dive to depths of 200 feet. They can fly, too--up to 60 miles per hour--but must maintain a rapid wingbeat to stay airborne. The webbed feet of loons are large and placed near the rear of their body. Such feet, though excellent for propelling their owners underwater, are the cause of misery should the loon be stranded on land. Then, it must move by hopping or else by scrambling on its stomach.

CASPIAN TERNS (Sterna caspia)

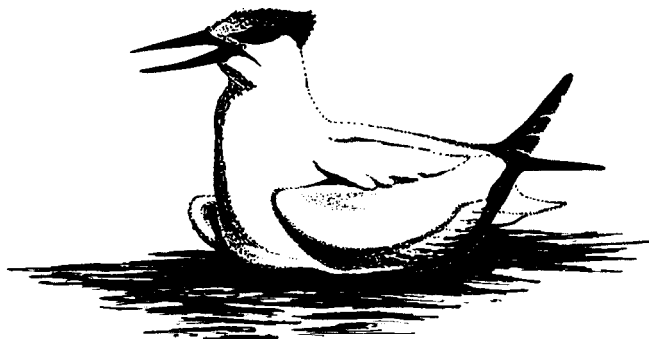

Caspian terns resemble seagulls until you notice the blood-red bill, black cap, and forked tail. With their narrow wings, they fly more agilely than gulls and may plunge underwater to pursue small fish. They breed in small colonies along the coast or inland on freshwater lakes, such as Klamath or Malheur. The call of these largest of terns is a big, guttural "kraaa."

GLAUCOUS-WINGED GULL (Larus glaucescens)



Glaucous-winged gulls are told from our other big gulls by their pink legs and pearly wings that lack black on the tips. When a storm rages offshore, they congregate on Oregon beaches and harbors. Like most gulls, they don't begin to breed until they're three years old, at which time their dingy juvenile feathers are replaced by spanking white and gray ones. Glaucous-winged gulls are most numerous on the coast but they also venture up the Columbia River and may winter around Portland.

PACIFIC HERRING (Clupea harengus)



Herring live in the ocean but enter the estuaries to lay their eggs. Herring are small fish, only six to seven inches long. They are a common food fish for larger fish such as salmon.

STARRY FLOUNDER (Platichthys stellatus)

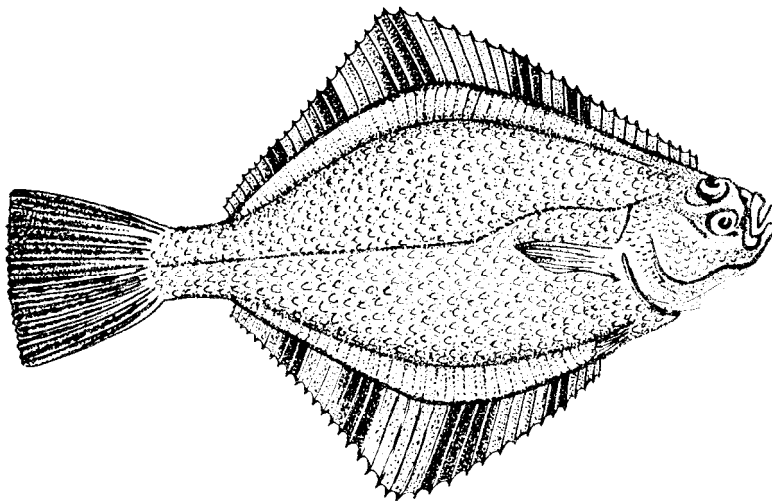

Starry flounder are commonly found in estuaries. They are caught by sport fishermen. They are considered very tasty. Like other flat fish, they have both eyes on one side of their head. However, when the fish are first hatched, their eyes are arranged in a more typical pattern on both sides. As they grow, one of the eyes will move over to one side.

HARBOR SEALS (Phoca vitulina)

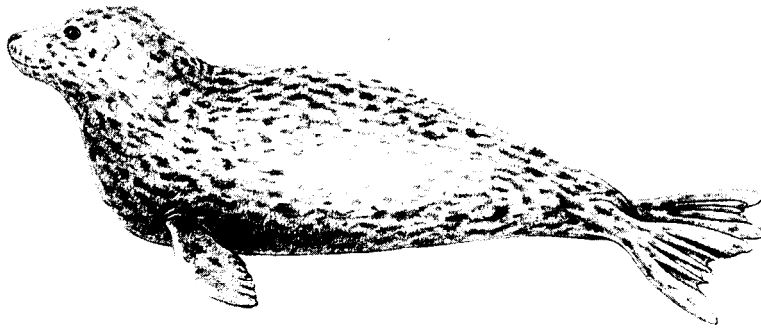

Seals are often seen hauled out on the sand bars or beaches. They enter the river in large numbers in January and February to feed on the runs of smelt that come into the river. They feed on a variety of fish including smelt and, to the disgust of fishermen, salmon.

CALIFORNIA SEA LIONS (Zalophus californianus)

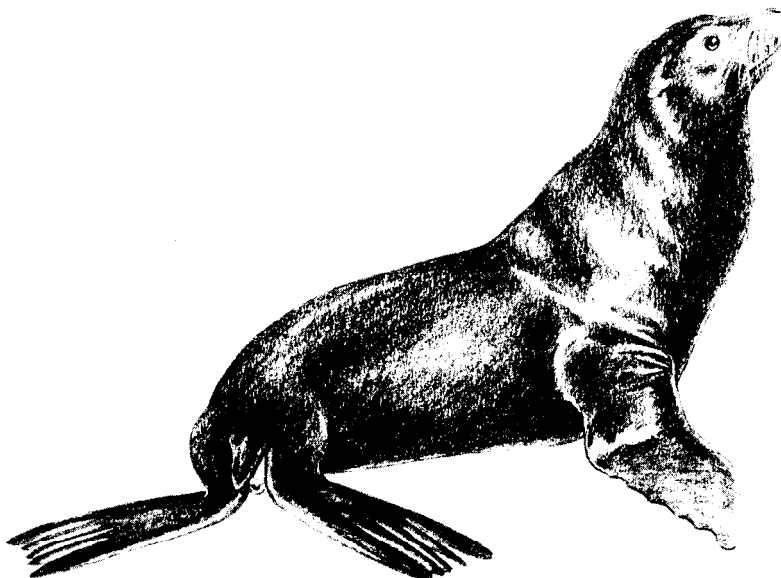

Both the California and northern sea lion are found in the Northwest but they do not enter the Columbia in large numbers. Like the seals, they feed on a variety of fish. They are often seen swimming in the river or occasionally hauled out to rest on the beaches.

COHO SALMON (Oncorhynchus kisutch)

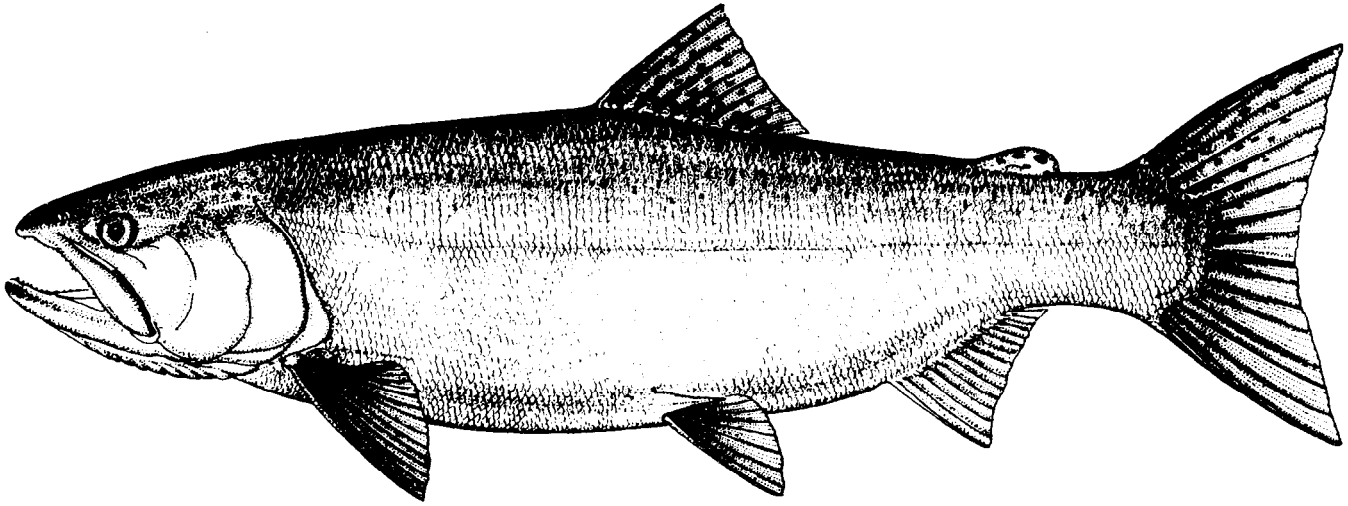

Coho is the most common of the four species of salmon in Oregon. Like other salmon, they lay their eggs in rivers. Upon hatching, they migrate to the ocean, where they spend two years feeding and growing. They return to the same river in which they were hatched to lay their eggs. They build a nest in the gravel called a redd, lay their eggs, then die.

EELGRASS (*Zostera* sp.)

This is a marine plant that is not an algae. Eelgrass is different than algae in that it has flowers, stems, and roots. Eelgrass beds are very important feeding areas for a small black goose called a brant. Eelgrass is found growing on mud areas which are exposed by low tides.

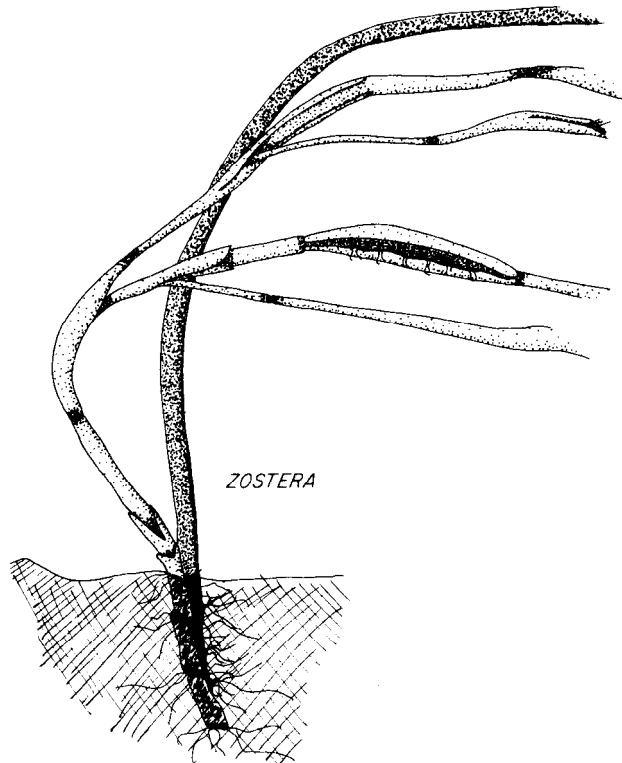



DIATOMS AND DINOFLAGELLATES (many times enlarged)

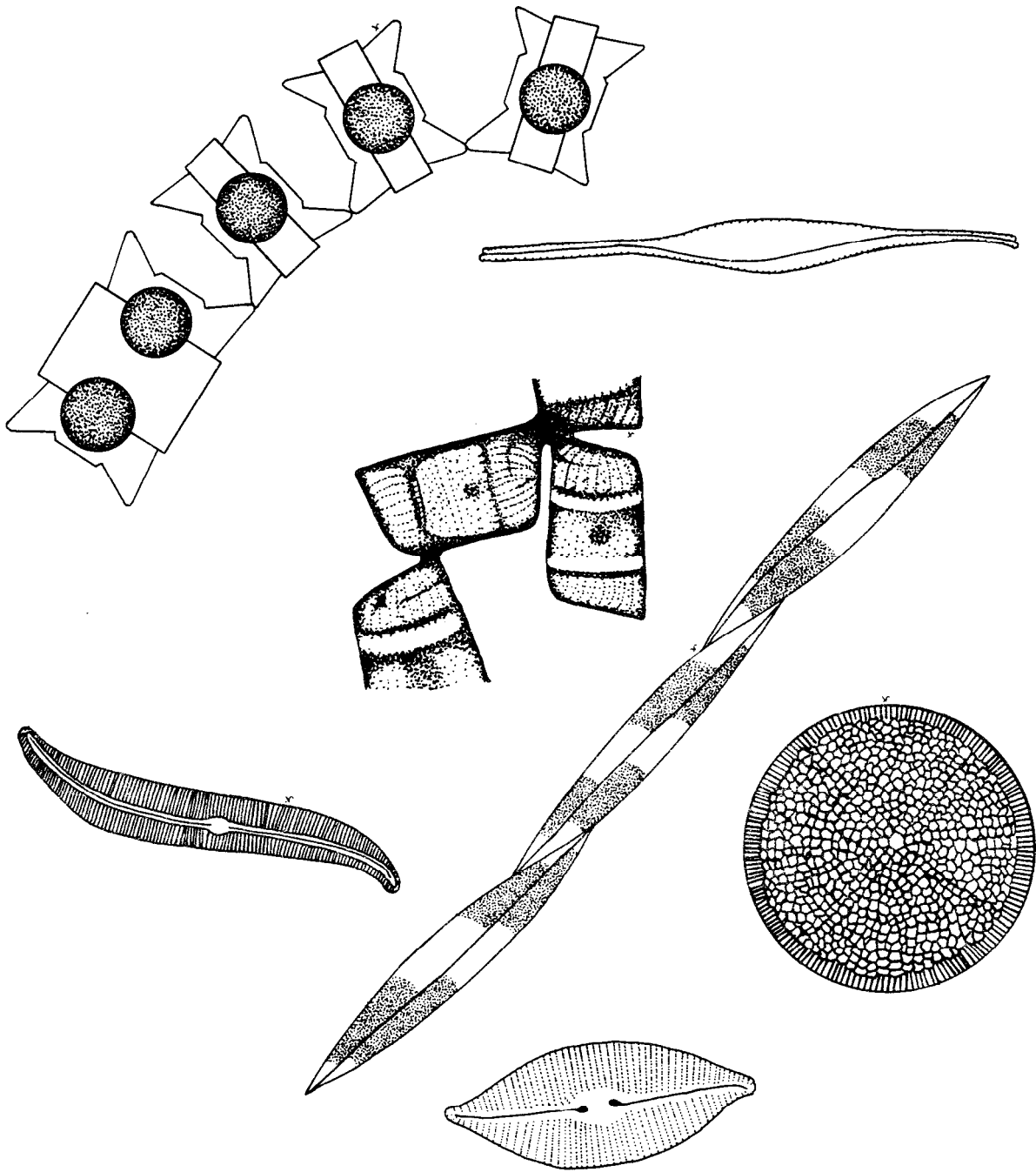

These tiny plants drift in the water and are the primary food for zooplankton, the tiny animals which live in the water. Both phytoplankton and zooplankton are visible only with a microscope.

A Little Coastal Town

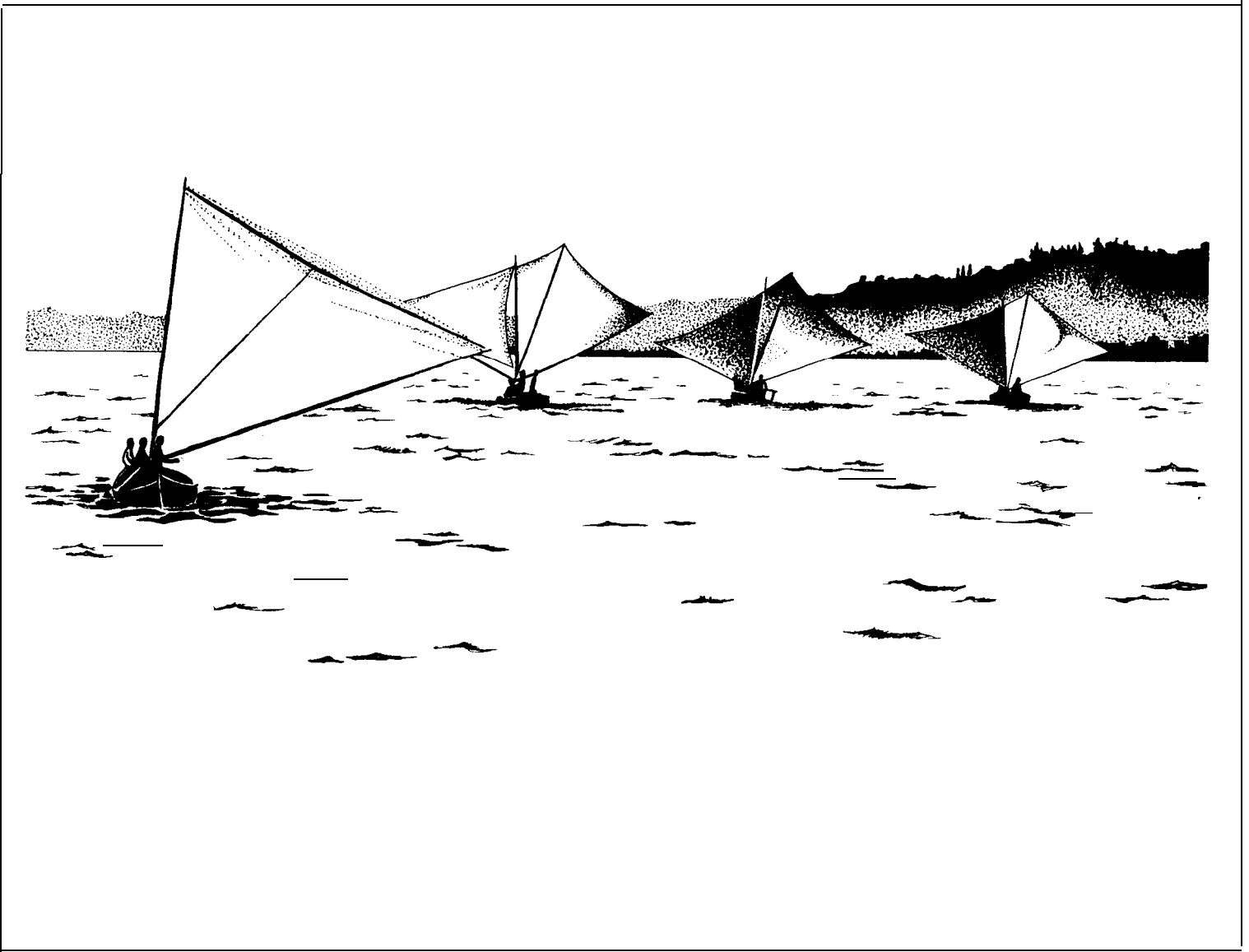

## A Little Coastal Town

For centuries the Clatsop and Chinook Indians lived on the wooded banks of the Columbia River. They got much of their food from its waters. They built sturdy canoes, which they paddled around the bars and through the rough water of the estuary. That way of life began to change in May 1792 when Captain Robert Gray became the first white man to sail into the river which he named after his ship, the Columbia. Nineteen years later John Jacob Astor built a fur trading post at what is now Astoria, Oregon.

Astoria grew very slowly in the early years, but by the 1850s more and more men had discovered that the abundant salmon could bring them more money than could the "soft gold," or fur trade. Fishing led to the opening of canneries; at one time, there were 55 salmon canneries along the lower Columbia River. Though many of the early settlers were from Scandinavia, England, and other European countries, Chinese and Hindus from India were contracted to work in Astoria. Some settled there.

The harvesting of trees became an important industry. Today, logs and lumber are Astoria's major export. But even in early Astoria, wood was important. Many blocks of the town were built on planks, set on pilings, and extended out over the Columbia River. The businesses and hotels on the wharves threw their garbage into the water through holes in their floors. Bears often came down to the river's edge to feast.

The billowing sails on the ships and fishing boats gave way to 400-foot freighters and gasoline-powered trollers. Horse-drawn streetcars and taxis vanished with the coming of the train and the motor car. But Astoria never became a large city. It remains a small, picturesque port town, proud of its past and hopeful about its future.

A life-long resident, Nellie Johansen, tells this story from her Astoria childhood:

"I remember well the August day in 1905 when Wan Kee came to our house for dinner for the very first time. Wan Kee was the contractor for all the Chinese workers in the Astoria salmon canneries. I remember that he brought my brother, Albert, and me some lichee-nut fruits in a fancy Oriental box. But what happened earlier that day I will never forget!

"First of all, Mama said I could wear my hair in long curls rather than the tight braids she usually made to keep my curly hair looking neat. As I slipped into my blue calico dress and buttoned my black high-topped shoes, Mama said I was to go to the meat market and ask Mr. Larson for a nice pork roast. Mama was planning to make her special Norwegian pork with cream gravy and applesauce for dinner. She said I could stop on the way to see Aunt Lottie at the cannery where she worked and to visit Papa at the salmon receiving station.

"Mama told me to try to stay tidy and warned me sternly not to lose the money. She said to me, as she had many

times before, 'Look before you leap, Nellie.'

"I was mighty tired of hearing those words even though I supposed I deserved them. The year before, on my eighth birthday, Mama and Papa had given me a parasol with a pink-rose design and edged with ruffles. I was so proud of that beautiful parasol! But, one day, I became curious to see if my parasol would fit in the cracks between Astoria's plank sidewalks. Some of the cracks were almost two inches wide. Well, I lowered the parasol right to its handle when suddenly it opened up. I tried to close it but it slipped from my hand and into the Columbia River. I never got a new parasol either. Another time I had a two-bit piece (twenty-five cents) Papa had given me for taking all the seaweed out of the gillnet he used for salmon fishing. It was a hard job and two bits was a lot of money! I decided to go to Hoefler's and treat myself to a big ten-cent dish of ice cream; I would save the other fifteen cents to help pay for my school books. But then, I saw a nice round knothole in one of the planks. I wondered and wondered if that two-bit piece would fit through that hole. It would, and did, and I expect it might be in the Columbia yet.

"That memorable morning, I walked along the beach in front of our house, past the small homes of our Yugoslavian neighbors. As I looked out at the busy harbor, I could see a large sailing ship being met by two tugboats. Some of the gillnetters were just coming in from a night of fishing. With their large, triangular sails of many colors, it was

easy to see why they were called the 'butterfly fleet.' I could hear bells clanging and then saw a big sternwheeler steamboat casting off its lines. The wheel began to churn and from its pipe-stacks came a cloud of steam and smoke. The T. J. Potter was on its way to Portland. I had ridden on it only once. I got to daydreaming then about the Regatta. Every August there was a week of festivities when sailing ships would be decorated with banners; there would be parades on the river, rowing races, beautiful floats and townspeople dressed in costumes of their native lands. It was tremendous fun!

"The discarded, rotting fish parts left an unpleasant odor down along the wharves and stopped my daydreams. But mingling with those smells were better ones coming from the cannery mess halls where Chinese cooks made the meals for the boarding cannery workers. One of the men, in his dark jacket and trousers, and with a long pigtail hanging down his back, bowed as I walked past. I stopped to watch a Chinese worker take a huge salmon from a heaped pile of thirty to sixty-pound fish, cut off the head, the fins, and then clean the salmon with a few sure strokes, all in less than a minute. The salmon was then put into a series of vats until the water ran clear and clean. I passed other workers who were chopping the fish into sizes suitable for tins. We had heard there was a new machine that would soon be doing this work. Next, I went into the wrapping and labeling room where I watched Aunt Lottie put colored



tissues around each salmon tin and give the ends a quick twist before passing it on to another lady who put on the handsomely designed labels.

"From the cannery, I walked along the wharves to the Altoona Cannery Receiving Station. Papa was in charge of taking in and weighing the salmon as the fishermen, mostly Swedes, Finns, and Norwegians, brought them in. Papa was a gillnet fisherman until he lost his brand-new net to a purse seiner's net the first night out. Purse seiners had huge nets that they drew up like drawstring purses, catching inside many other things besides fish, such as logs, or gillnets, which were then torn to pieces. I often heard Papa grumble about the seiners and the trappers. The trappers caught large amounts of fish near the mouth of the Columbia before they could get far enough into the river to allow the gillnetters a fair share, according to Papa. Hoping to go back to fishing eventually, Papa was now making his own nets at home. I helped him by winding the twine for knitting the nets onto a bobbin. For each one I wound, I got a penny toward my school books.

"The dock near the receiving station was filled with racks for drying nets. One of the fishermen was mending his net with a wooden shuttle, which helped in knotting the linen twine. Inside were the bluestoning vats, huge tubs filled with water into which a measured amount of bluestone, or cupric sulfate, was dissolved. The nets were dipped into these vats and the bluestoning helped preserve them.



"Papa was standing beside the large wooden box into which the fish were deposited. A crane lifted the box, it was weighed, and each fisherman was given a fixed price per pound. This was credited to his account, if he fished for the cannery. Throughout the fishing season, any costs for nets or other gear for his boat were subtracted. At the end of the season, he would either make a profit or be in debt to the cannery. A highliner was the fisherman who caught the most salmon in a season.

"It was a short walk up the hill from the receiving station to Larson's Meat Market. I stopped to say 'hello' to Mr. Utsinger at his stationery store, and ask if he had fed his cat, Samson. He said he had been waiting for me to help him. We went to the back of the store and sat on boxes beside a hole in the floor. Samson sat near us, waiting. Mr. Utsinger baited a line and handed me the pole. I let it down into the dark, gently lapping water of the Columbia River. It was not long before I felt a tug on the line and pulled up a small tomcod. With Samson fed, I went on up the street.

"Mr. Larson helped me choose a pork roast. He wrapped it several times in a heavy, tan-colored paper and tied it securely with string. I paid Mr. Larson, counted my change, and started home. For awhile, I carried the package under my arm, but when it began to leak in spite of the heavy paper, I looped and twisted the string around my finger and carried it in my hand. As I walked along, I played some

jumping and skipping games. When they got boring, I turned around and began walking backward. Suddenly, I was falling, down, down into cold, black, murky water. Fortunately, the tide was out, the water was not deep, and I was not hurt--except for my pride. However, my dress, my shoes, my long stockings, and my flour-sack petticoats and bloomers were wet and muddy. Salt water and bits of seaweed were dripping from my wet curls. But the meat, its wrapping soaked, was still firmly attached by its string to my finger."

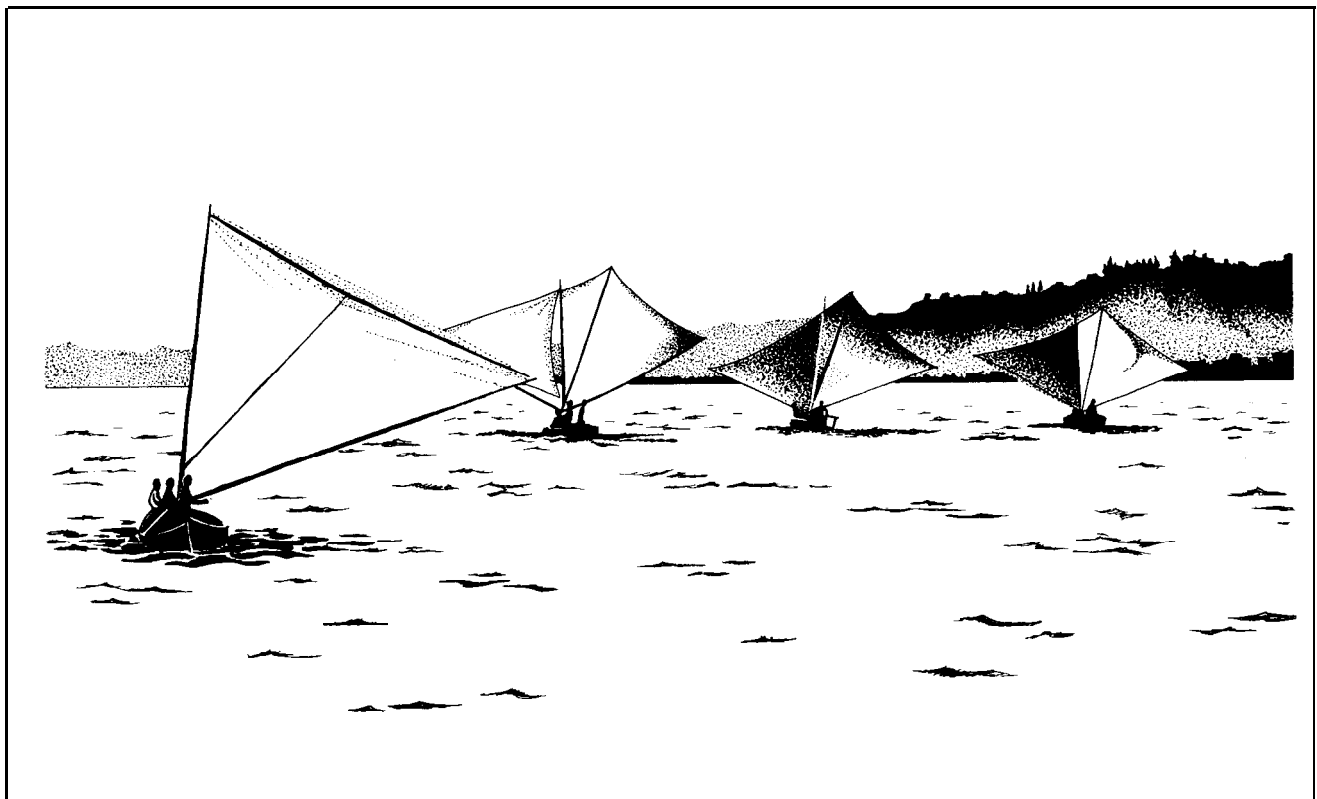

## **Part Three: Vocabulary**

## Vocabulary List

Learn these words before reading "The Captain Comes into Port."

buoy: a floating structure used to mark the entrance to the harbor

bridge: the part of the ship where steering and control of the ship occur

shipmaster: the captain of the ship

quartermaster: one of the officers on board the ship

bar pilot: a person who guides ships over the bar into the harbor

radar: a system that bounces radio waves off objects so that they can be seen in the dark or fog

pilot boat: the boat used to bring the bar pilot to meet the ship

draft: the depth of the water between the waterline and the bottom of the ship

jetty: a long, rock wall that protects the mouth of a harbor

headland: a point of land that juts out to sea

tugboat: a small, strong boat that assists large ships into dock

berth: a place in the water alongside the dock

stern: the back part of the ship

bow: the front part of the ship

ebbing: the flow of water in a seaward direction produced by low tide

longshoreman: a person who loads and unloads ships

crane: a large machine used to load and unload ships

scribner: a unit of measurement for logs

## Vocabulary List

Discuss these terms before reading "Bringing Ships into Port."

channel: that part of the harbor that is deep enough for ships

bar: an underwater bank of sand at the entrance to a harbor. The bar makes the water more shallow than in surrounding areas. Only those harbors that are on a river have a bar.

radar: a system that bounces radio waves off objects so that they can be seen in the dark or fog

bar pilot: a person who guides ships over the bar into the harbor

dredging: scooping sand and mud from the bottom of the harbor

Merchant Marines: large, commercial ships owned by the United States

U.S. Army Corps of Engineers: the agency which is in charge of dredging the harbor

shipmaster: the captain of a ship

sea pilot: another name for bar pilot. Sea pilots work on bays that do not have a bar.

bridge: the part of the ship where steering and control of the ship occur

longshoreman: a person who loads and unloads ships

## Vocabulary List

Discuss these terms before reading "A Day in the Life of a Tugboat Captain."

tugboat: small, strong boat that assists large ships into docks

velocity: the speed at which an object, be it wind, water, or a vehicle, is moving

flood tide: high tide

bow: the front part of the ship

stern: the back end of the ship

bar: an underwater bank of sand at the entrance to a harbor. The bar makes the water more shallow than in surrounding areas. Only those harbors that are on a river have a bar.

## Vocabulary List

Learn these words before reading "Cradle of Life--the Columbia River Estuary."

biologists: people who study plants and animals

estuary: a place where a river meets the sea and where fresh water and salt water mix

brackish: a mixture of fresh water and salt water

waterfowl: birds that live close to the water

rushes, reeds, and sedges: different types of plants that grow near the water

predators: animals who hunt and feed on other animals

redd: the gravel nest that salmon build

tickle chains: chains at the front of nets that drag along the floor

seining: dragging a net through the water to catch fish

diatoms: tiny one-celled plants that drift in the water

copepods: little flea-like animals that live in the water

## Vocabulary List

Discuss these terms before reading "A little Coastal Town."

estuary: a place where a river meets the sea and where fresh water and salt water mix

cannery: a place where fish or other food is canned

parasol: small umbrella

gillnet: a large net that is used in the river to catch salmon. The fish try to swim through the net and are caught in the net by their gill covers,

wharves: another word for docks. Structures built alongside the water that ships may tie up to.

purse seiner: a fishing boat which fishes with a net that can be closed at the bottom to capture the fish

wooden shuttle: a small structure that string can be wound around. Used in repairing nets.

tomcod: a silvery fish that occurs in the Columbia River estuary

cupric sulfate: a chemical which was sometimes used to preserve nets



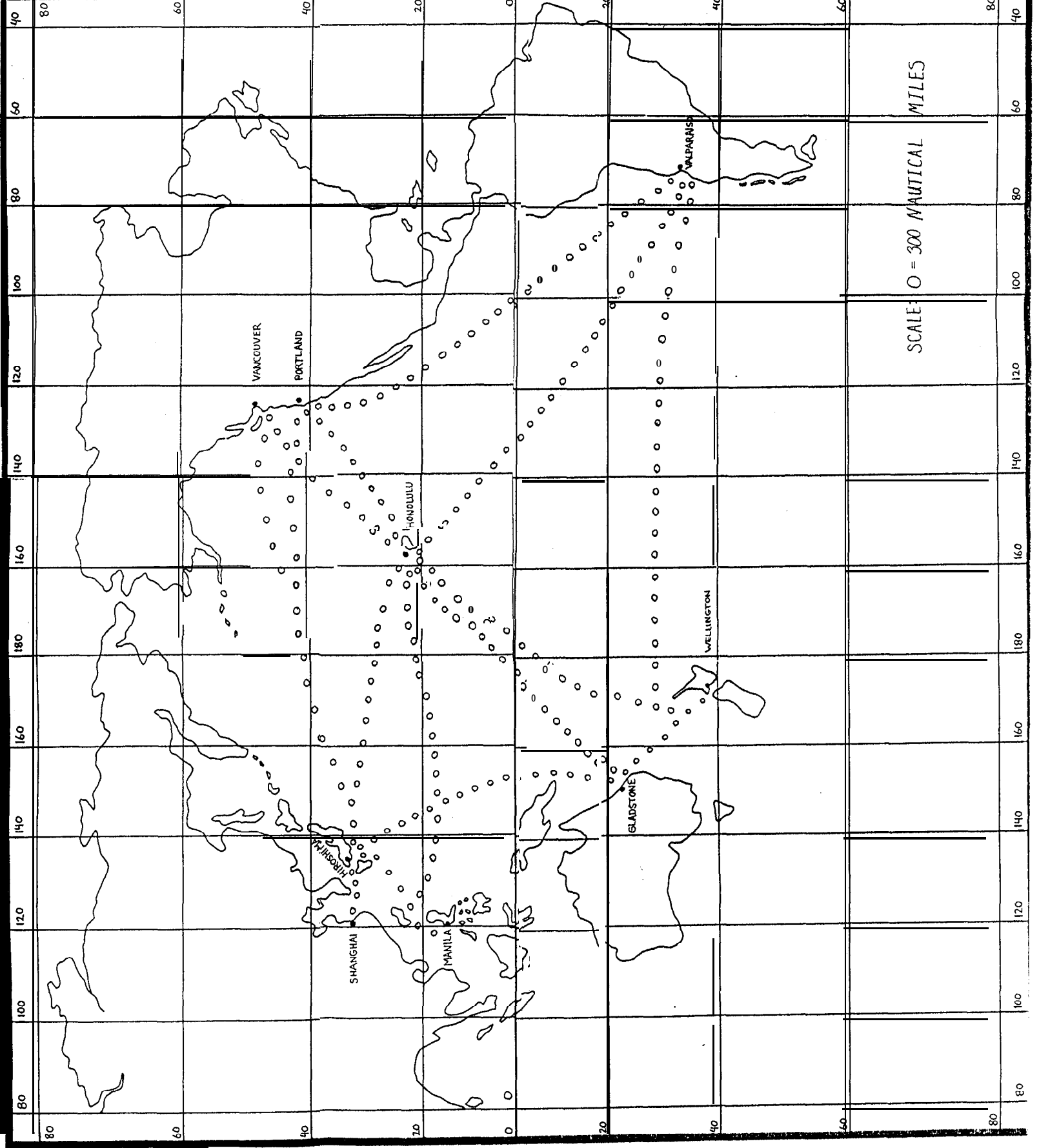

VANCOUVER

PORTLAND

HONOLULU

SHANGHAI

MANILA

GLADSTONE

WELLINGTON

VALPARAISO

SCALE: O = 300 NAUTICAL MILES

