

**NOAA**  
**FISHERIES**

# At-Sea Hake Observer Program

**2022 Sampling Manual**

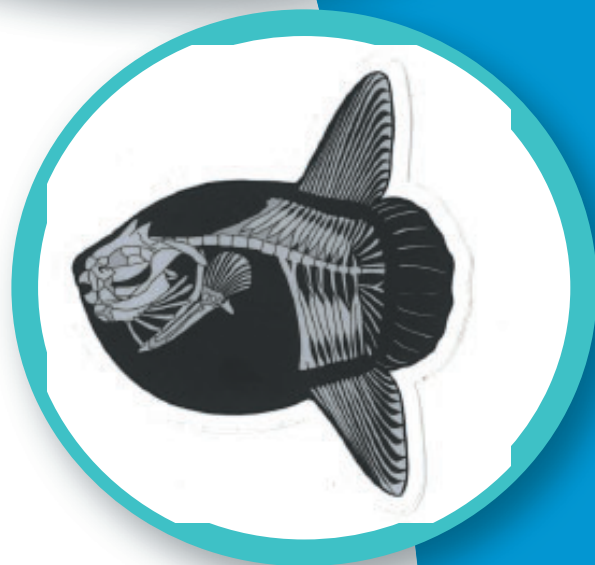

## **Paperwork Reduction Act Statement for the At-Sea Hake Observer Program**

Information collected through the observer program is used to: (1) monitor catch and bycatch; (2) understand the population status and trends of fish stocks and protected species, as well as the interactions between them; (3) determine the quantity and distribution of net benefits derived from living marine resources; (4) predict the biological, ecological, and economic impacts of existing management actions and proposed management options; and (5) ensure that the observer programs can safely and efficiently collect the information required for the previous four uses. In particular, these biological and economic data collection programs contribute to legally mandated analyses required under the Magnuson-Stevens Fishery Conservation and Management Act (MSA), the Endangered Species Act (ESA), the Marine Mammal Protection Act (MMPA), the National Environmental Policy Act (NEPA), the Regulatory Flexibility Act (RFA), Executive Order 12866 (EO 12866), and other applicable law. Most of the information collected by observers is obtained through "direct observation by an employee or agent of the sponsoring agency or through non-standardized oral communication in connection with such direct observations". Under the Paperwork Reduction Act (PRA) regulations at 5 C.F.R. 1320.3(h)(3), facts or opinions obtained through such observations and communications are not considered to be "information" subject to the PRA. The public reporting burden for responding to the questions that observers ask and that are subject to the PRA is estimated to average 20 minutes per trip, including the time for hearing and understanding the questions, searching existing data sources, gathering and maintaining the data needed, and completing and reviewing the collection of information. Send comments regarding this burden estimate or any other aspect of this collection of information, including suggestions for reducing this burden, to: At-sea Hake Observer Program, 2725 Montlake Blvd. East, Seattle, WA 98112. Providing information related to observer and vessel safety is mandatory under regulations at 50 C.F.R. 600.746. However, all other requested information is voluntary. Although you are under no legal obligation to answer non-safety related observer questions, we would appreciate your support as it ensures observer data can be used for its intended purpose. The information collected will be kept confidential as required under Section 402(b) of the MSA (18 U.S.C. 1881a(b)) and regulations at 50 C.F.R. Part 600, Subpart E. Notwithstanding any other provision of the law, no person is required to respond to, nor shall any person be subject to a penalty for failure to comply with a collection of information subject to the requirements of the Paperwork Reduction Act, unless that collection of information displays a currently valid OMB Control Number. OMB Control No. 0648-0593

*Cite this document as follows:*

(NWFSC) Northwest Fisheries Science Center, At-Sea Hake Observer Program, 2022 Sampling Manual. Fishery Resource Analysis and Monitoring, At-Sea Hake Observer Program. NWFSC, 2725 Montlake Blvd. East, Seattle, Washington 98112.

Reference in this document to trade names does not imply endorsement by NOAA Fisheries.

**Cover art by A-SHOP observers Lauren Ackein (canary rockfish painting), Anna McBee (mola mola sticker), and Nancy Franco (Three Gulls drawing).**

### **FUN FACT:**

**The name Salmon shark may be a misnomer. Data collected by A-SHOP observers last year showed that they consume a varied diet including hake, rockfish, flatfish and some squid. Apparently no salmon were harmed by these particular sharks! At least not in the near term.**



## Table of Contents

<b>OVERVIEW</b> .....	4
Safety .....	4
Observer Regulations and Coverage .....	5
Data Confidentiality .....	5
Hake Fishery Background and Information.....	6
Bycatch Limits and Coordinating with Vessel Crew.....	7
Vessel Regulations.....	9
Identification Verification and Signing Documents.....	10
<b>SAMPLING AND BIOLOGICAL DATA</b> .....	11
Observer Priorities .....	11
Priorities and Time Management.....	11
Observer Catch Reporting.....	12
Marine Mammals, Seabirds, and Sea Turtles.....	12
Observer Catch Estimates.....	13
Scale Testing.....	14
Ensuring Accurate Weights .....	15
Presorted Organisms.....	16
Length-to-Weight Tables for Large Organisms.....	16
Set Up a Random Sample Design.....	17
Species Composition Sampling .....	18
Sampling Options.....	19
Subsampling For Two Predominant Species .....	21
High Bycatch Sampling .....	23
Average Weight Samples.....	24
Percent Retained and Estimated Discard Weight .....	25
Mothership Catcher Vessel Discard Accounting .....	26
Species ID Forms.....	27
Prohibited Species .....	28
Protected Fish Species Sampling.....	28
Salmon.....	29
Salmon Biospecimen Sampling .....	30
Coded-Wire Tag Sampling.....	30
Chinook and Coho Genetic Sampling .....	31
Using the Salmon Sampling Deck Form .....	33
Biospecimen Sampling.....	34
Biospecimen Sampling Protocols.....	34
Genetics .....	36
Spiny Dogfish Protocols .....	37
Fish Collection .....	38
Entering Specimen Data in ATLAS.....	38
Data Quality Control .....	40
Communication .....	40
Mid-Cruise .....	41
Debriefing and Specimen Turn-in .....	41
Gear Check-Out and Care .....	42
Gear Check-in Protocol.....	42
<b>APPENDICES</b> .....	43



This manual is a supplement to the North Pacific Observer Program Manual, which is more detailed, particularly about safety. Please review Chapter 19 in the NPOP manual for an in-depth safety review.

## **Safety**

This safety information builds on the foundation of knowledge and skills you have gained through your Alaska training and experiences. This chapter will focus on safety topics specific to the hake fleet off the West Coast.



**Safety must be every observer's top priority.** When you board your vessel, both observers need to physically locate each piece of equipment on the vessel safety checklist, fill out the checklist, and sign the form. Any observer who fails to complete the vessel safety checklist will receive an automatic zero as an evaluation score, because they failed to recognize safety as their number one priority. Out at sea, you must take responsibility for your own safety and do everything within your power to be aware of and avoid known dangerous situations.

### **Specific safety goals:**

1. Create an emergency plan with your partner.
2. Understand the vessel's evacuation plan: where will rafts be launched/boarded, how will crew immersion suits be distributed, how will information be communicated, etc.
3. Learn location of hydraulic shut-off(s) in observer sampling area; confirm that the sorter you work with knows hydraulic shut-off locations.
4. Be aware of diverter board and conveyor belt pinch points.
5. Use hearing protection in the factory.
6. Be extra vigilant during at-sea transfers. Complete the "Transport Vessel Safety Profile" in your logbook for all at-sea transfers and skiff rides.



## **Bed Bugs**

Be aware of the possibility of bed bugs on your vessel. Refer to Appendix J for information on detection and mitigation of bed bugs.

## **COVID-19**

The pandemic landscape is evolving quickly, but please remain vigilant and take precautions to stay healthy. During your safety orientation, feel free to ask what precautions the vessel is taking against COVID-19. Observers must comply with vessel procedures such as mask wearing, temperature checks, etc.

## **Observer Regulations and Coverage**

Regulations requiring 100% observer coverage for catcher-processors (C/Ps) and motherships (MS) went into effect in 2004, though observers have been deployed in the hake fishery since 1975. From 1975-2000, observers on hake vessels were deployed by the North Pacific Observer Program. The At-Sea Hake Observer Program (A-SHOP) in its current form began in 2001, at the same time as the West Coast Groundfish Observer Program, to manage observers deployed along the West Coast. Currently, the mothership and catcher-processor sectors both operate under cooperative agreements (co-ops) which are part of the West Coast catch shares program.

## **Data Confidentiality**

Keep all observer information confidential. Observers may not post observer information on the internet, including but not limited to social media, blogs, and file sharing sites. Observer information is defined as: any information collected, observed, retrieved, or created by an observer, including fish harvest or processing observations, fish sampling or weighing data, vessel logbook data, vessel or processor specific information (including any safety, location, or operating condition observations), and video, audio, photographic, or written documents.

Keep your data secure at all times. All data including deck sheets, forms, and your logbooks should not be left out unattended where anyone can potentially access it.

While the A-SHOP currently allows the use of personal cameras, *photographs and videos taken while deployed as an A-SHOP observer may not be posted on the internet!*

## **Data Integrity**

Observer data is a cornerstone of sustainable fisheries management. NMFS relies on observers as professional biologists, to collect unbiased, high quality data. You should be striving to collect the best data possible. Data integrity is integral to a successful relationship with all of our partners and stakeholders. If you ever have questions about the data, please reach out to the program.

## **Hake Fishery Background and Information**

While the vessels and sampling situations will be familiar to experienced North Pacific observers, the regulations, management, and species encountered in the hake fishery are different from those in Alaska. The at-sea Pacific hake (*Merluccius productus*) fishery, known commercially as whiting, dates back to 1966 when foreign vessels participated. The fishery evolved into a joint venture with U.S. catcher vessels delivering to foreign processing vessels in the 1980s. By 1991, the hake fishery was completely domesticated, allowing only U.S. vessels to catch and process fish.

The fishery opens May 15 and the last day of fishing allowed is December 31. Typically, there is a ‘spring season’ (mid-May through June) and a ‘fall season’ (late August through November). Trip durations range from 10 days to three weeks, depending on the vessel and the season. In the spring, vessels typically fish hake for one or two trips. In the fall, vessels may plan to fish more trips and the trips may be longer.

### **The at-sea hake fishery consists of three sectors:**

1. Motherships
2. Catcher/Processors
3. Tribal

The Total Allowable Catch (TAC) for hake is allocated to each sector as a percentage of the annual total. A portion of the U.S. TAC is allocated to the tribal sector and the remaining TAC is divided between the C/P sector (34%), the MS sector (24%), and the shoreside sector (42%). Check out the “Whiting Report” at <http://pacfin.psmfc.org> for in-season data (your data!).

The hake tribal fishery is exclusive to the Makah, Quileute, Hoh, and Quinault tribes from the Washington coast. To date, only the Makah tribe has participated in the fishery. All hake fishing for the tribes takes place in each tribe's Usual and Accustomed Areas (UAA) by tribal catcher vessels. Figure 1 shows the boundaries for the four tribe's UAAs. The Makah area extends north of the area illustrated here, but is shown within the bounds of both the fishery management area and the U.S. exclusive economic zone (EEZ).

In the tribal fishery, observers on the mothership sample all hauls as usual. Enter a tribe-specific code in the "CDQ/Tribal code" column on the Vessel Haul Form (VHF), for each tribal haul. This does not mean it is a CDQ fishery, but simply designates the delivery as a tribal haul. M01 (M zero one) is the Makah tribal code. The tribal catcher vessels may not carry observers or have electronic monitoring (EM), unlike in the mothership sector.

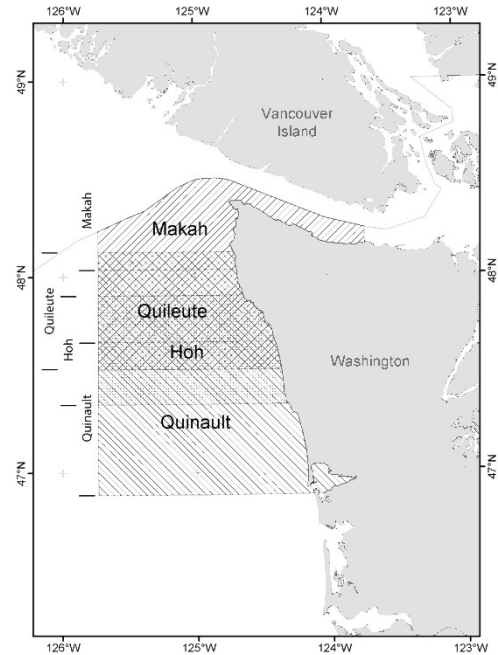

**Figure 1 Tribal Usual & Accustomed Areas**

**Bycatch Limits and Coordinating with Vessel Crew**

Recently, the status of several species of rockfish has changed from overfished to rebuilt - welcome news for West Coast fisheries. These status changes have helped relieve some of the pressure the hake fishery has felt for bycatch of POP, canary, darkblotched and widow rockfishes. However, given the historically high hake quotas of recent years, there are still challenges to utilize the full hake quota while staying within the set-aside amounts allowed for bycatch of a particular species.

The term "species of concern" refers to any bycatch species that is potentially limiting to the fishery. This includes Chinook salmon and any species with potentially low set-asides (i.e. catch limits). Which species are considered "species of concern" can and does change, particularly as the season progresses. The species listed above, as well as sablefish, shortbelly rockfish and at times, spiny dogfish, could all potentially limit the fishery. Communicate with the captain about current species of concern.

In 2004, the at-sea hake fishery came close to catching the entire canary rockfish allocation in one haul. Since then, significant bycatch events have caused challenges and brought increased attention to our sampling methods. This serves as a reminder that observers should use the tools available to them and maintain large sample sizes whenever possible. The vessels continue to be interested in working with the observers to maximize sample size when a species of concern is present in the haul.

Several strategies have proven very effective and are outlined below.

Please contact the Observer Program with any questions.

---

Maintain communication with the captain about species of concern throughout your deployment.

---

1. **Pre-cruise bycatch discussion:** Before fishing begins, it is a good idea to discuss bycatch concerns with the captain and factory supervisor(s). Refer to the '*Pre-Cruise Bycatch Discussion Outline*' in the appendix.
  
2. **Notification of species of concern:** If you are watching the codend dump and notice large amounts of species of concern, make sure the vessel is aware of the situation. This is a good time to indicate to the factory manager/foreperson that you will need help. Occasionally, for hauls with large amounts of species of concern, the captain or mate may request the haul be censused. If the following criteria are met, the A-SHOP requests you census the haul:
  - No fish have been run yet, or you have sampled all of the haul up to that point
  - You determine the request is reasonable, due to:
    - A large amount of species of concern are present
    - The vessel will provide appropriate assistance, including breaks if necessary
  
3. **Help for the observer:** Every vessel has demonstrated that they are willing to help the observers during hauls with high bycatch of species of concern. They may do this by designating someone from the crew to assist the observer - to help sort, lift, and carry. Full supervision of this person is required at all times. You cannot leave this person unattended at the belt to sort while you weigh bycatch or collect biological data.

NOTE: In order to get assistance from the vessel, you must *ask for help*.

4. **Adjust the flow of fish:** To maintain a large sample size, try adjusting the flow of fish. This might mean slowing the belts before the sorting belt so you are able to collect every piece of bycatch, or speeding up the sorting belt to thin out the layer of fish for easier sighting of bycatch. Ideally, this would allow you to obtain larger samples than would be possible without another person assisting.





As the observer, you need to keep in mind that collecting the largest sample possible is a high priority, but you can only achieve that if every piece of bycatch can be collected. Ultimately, sample size is dictated by your ability to collect all bycatch in the sample. If you are unable to obtain a large sample for a haul with species of concern, be prepared to describe to the captain and/or factory manager what it was that prevented a larger sample from being collected and, if possible, work with them to prevent it from happening again.

**Vessel Regulations**

NMFS’s West Coast Region does not currently issue vessel logbooks in the hake fishery. Instead, the captain will record haul information in a generic logbook, or an electronic logbook (ELB), from which you will get the VHF data. Double check for transcription errors between the vessel’s haul information, the VHF, and ATLAS. Get copies or printouts of the vessel’s haul information on a daily basis, to turn in for debriefing.

Verify sample station dimensions to ensure compliance and document any corrections that need to be made. Ask for a copy of the vessel’s sample station certification letter. Measure actual sample station dimensions and record in the Sample Station Verification Checklist in your observer logbook.

**MARPOL regulations:**

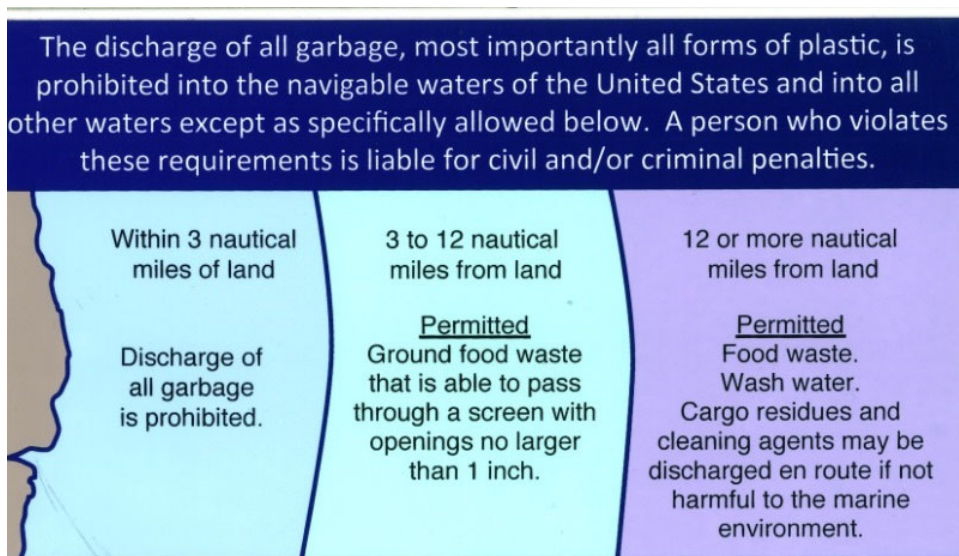

---

Observers record what they see, but interpreting regulations for the vessel is not part of observer duties.

---

**West Coast fishing regulations to note:**

**No processing zone:** No at-sea processing is permitted south of 42.00 N (the California-Oregon border). Mothership catcher vessels may fish south of 42.00 N, but must return north to deliver the fish.

**Retention:** The vessel is entirely responsible for knowing which species they may or may not retain. If someone on the vessel asks you if they are allowed to retain something (e.g., a tasty-looking rockfish) do *not* try to interpret any rules; instead, direct them to the factory manager or captain. As an observer, you are not responsible for interpreting any regulations.

### **Identification Verification and Signing Documents**

The U.S. Coast Guard is required to obtain information on all vessels that could transport foreign nationals into the country. Prior to entering a port, each vessel must submit the full name, date of birth, nationality, identification information, and position or duty on the vessel, as applicable, of each crew and passenger. The Real ID compliant identification you use to get your observer badge - Driver's License or Enhanced Driver's License (depending on the state) or U.S. passport - fulfills this requirement.

Do not sign any document related to your data collection or duties. Sign the flow scale test record form to indicate you witnessed it, if your vessel is not using an ELB. You may also be asked to sign documents or forms *not* related to your data collection or duties, which may include safety or compliance issues, or video release forms. Contact your employer and the Observer Program for advice on how to proceed if this happens. Additionally, written statements should be prepared only for NMFS staff. If vessel personnel want more information, please have them contact the Observer Program.



### **Observer Priorities**

1. Personal safety
2. Marine mammal, seabird, and sea turtle samples
3. Haul information and catch estimates
4. Species composition samples
5. Species ID forms + photos
6. Protected species samples (salmon & sturgeon)
7. Biospecimen samples
8. Monitor gear retrieval for marine mammals and seabirds
9. Special projects, as assigned
10. Fish collection and other tasks

### **Priorities and Time Management**

Complete your observer duties in *order of priority*. There may be hauls where you are not able to complete every task due to time constraints. Refer to the priority list to complete tasks as time allows. Keep in mind that the first couple of days in a new fishery can be overwhelming. It is not unusual to work more than twelve hours a day, particularly in the beginning of your cruise. Once you become familiar with the vessel's operations and complete most of your species ID forms, you will have a better idea of how to manage your time. Your in-season advisor is a helpful resource for any questions or concerns about priorities and time management.

## **Observer Catch Reporting**

Transmit your data via ATLAS once per day on a catcher-processor, and once per shift (twice a day) on a mothership. Enter and transmit non-fishing day positions on days when no fish are retrieved or delivered. This includes every day from the first day you board the vessel until the day you disembark. Ask your in-season advisor any questions you have while deployed and inform them of significant events (e.g. hauls with large amounts of species of concern, non-fishing days due to the vessel needing repair, mola sightings, etc.).

Observer catch estimates and species composition data are used by both NMFS and the vessel to track the hake and bycatch quotas. Wait until you have the final flow scale weights before transmitting data for a specific haul. Double-check your work, and your partner's work, to ensure data entry is accurate and correct.

Enter "HAK" in the purpose code field in ATLAS Haul Data to indicate the hake fishery. Observers on motherships need to record the ADFG number of the catcher boats that are making deliveries (see *Appendix D* for the list).

If ATLAS is not working, please contact Glenn Campbell as soon as possible at 206-526-4240. For all other problems and questions, please contact the A-SHOP (see *Appendix C*).

## **Marine Mammals, Seabirds, and Sea Turtles**

**Sampling:** *Sampling* marine mammals, seabirds, and sea turtles is your second highest priority. If one is caught in the gear, or ends up on deck, collecting the appropriate samples and information takes precedence over other sampling duties. Clearly label all mammal and bird specimens with the lead observer's cruise number, species name, and haul information. Please thoroughly describe the interaction and characteristics used to determine the species in the comments section. Use the A-SHOP issued camera to take photos of any marine mammal or seabird carcasses encountered.

**Mammals:** Collect a small tissue sample from all pinniped carcasses, label, and freeze in a plastic bag. (Note: DMSO is *only* for cetacean samples.) If you encounter a tagged or branded pinniped, please collect and freeze the entire snout (in addition to the tissue sample). This will allow researchers to use the vibrissae (whiskers) and canine teeth for aging and stable isotope studies. Do not record marine mammals in the species composition data, even if you discover it while sampling. Enter marine mammal data in the Marine Mammal Interaction and Specimen Form in ATLAS. Refer to the A-SHOP Wet Manual for instructions to collect pinniped specimens. In the rare case that you encounter a cetacean carcass, refer to Chapter 14 of the NPOP manual to collect specimens.



Report live entangled marine mammals to the NOAA Marine Mammal Disentanglement Hotline at 1-877-SOS-WHAL(e) (1-877-767-9425). See Appendix I for reporting instructions.

**Seabirds:** Albatross interactions are of particular interest in this fishery. Any sightings of short-tailed albatross are extremely valuable data and must be entered in ATLAS. Collect and freeze all seabird carcasses, except gulls. Complete the Bird Interaction, Activity and Species Form in ATLAS for all birds that interact with the vessel or gear, regardless of the outcome of the interaction. Record species, count, and weight in the species composition data for birds that occur in your sample. Observers on catcher-

---

**Short-tailed albatross** are a species of interest, and sightings off the West Coast have increased in recent years.

---

processors will enter the appropriate *Haulback Bird Obs Code* and *Shortwired* fields on the OHF. For mothership observers, the *Haulback Bird Obs Code* is always “0” for No Monitoring and *Shortwired* is always “U” for Unknown.

Record band data for banded birds and leave the bands intact with the carcass. Any information on live banded birds, including pictures, are also useful. Refer to Chapter 16 of the NPOP manual for detailed information on recording seabird sightings and interactions.

**Turtles:** Encountering a sea turtle is highly unlikely. If one is caught by the vessel, refer to the sea turtle guide included in the A-SHOP species ID guide. Most importantly, take photos of the carapace and head before returning it to the water. Inform the Observer Program as soon as possible if a sea turtle is encountered.

**Monitoring:** *Monitoring* for marine mammals and seabirds is lower on the priority list than sampling. Monitor gear retrieval and codend dumping for marine mammals and seabirds when you are not sampling for species composition. Monitoring for mammals and seabirds must be done from the trawl deck and is recorded as either 0 or 100% on the OHF.

### **Observer Catch Estimates**

All vessels are required by regulation to have flow scales and must test them once every day. Use the flow scale weight for the observer catch estimate, record a “W” on the OHF, and enter the flow scale weight in kilograms.

The flow scale is used by the vessel to record total catch weight for each haul. Keep track of which haul is running across the scale. Record the display weight at the end of each haul’s processing when you can.

Request copies of the vessel's flow scale end weight printouts *daily* to verify catch estimates and turn them in for debriefing. (see Appendix G: Flow Scale Documents for an example of the daily printout.)

If part of a codend is spilled or fish overflow through a blowout panel in the net, visually estimate the weight. Add the estimated weight to the flow scale weight for your total observer catch estimate (OCE), and to the discard for your total estimated discard weight. Also, adjust the percent retained accordingly. If an entire codend is lost, you or the captain should visually estimate the weight, and enter code 6 (codend lost) for gear performance on the VHF. Record this information in the Catch Estimate Calculations section of your logbook.

### **Scale Testing**

Please refer to the following guidelines when observing in the hake fishery. Each observer must test the motion compensated platform scale (MCP) during their shift. Test the MCP scale using certified weights at 10, 25, and 50 kg. Record the results on the decksheet and in the "Daily Observer MCP Scale Test Log" section in your logbook. A  $\pm 0.5\%$  variance is allowed to consider the MCP scale usable and accurate. The scale must pass this test in order for you to use it for your species composition sample, and for the flow scale test to be valid. If the MCP scale fails, try calibrating the scale, and then retesting.

---

Test the motion compensated platform (MCP) scale every shift. The flow scale must be tested each day.

---

The flow scale must be tested at least once each calendar day that it is used to weigh catch. Testing the flow scale is the vessel's responsibility, but an observer must be present for the test to be valid. It is the vessel's responsibility to conduct the test when the observer is able to be present. Work with the vessel so you can be present for the test at a time convenient to everyone. The crew will run 400+ kg of sand bags over the flow scale and then verify the weight of the same sand bags using the MCP scale. A  $\pm 3\%$  variance is allowed. The vessel will complete a daily flow scale test record form. For an example of the "Record of Daily Scale Tests", see Appendix G. There is a place for the observer who witnessed the test to sign the form. This simply means you witnessed the test, not that the flow scale passed. When you witness the test, check to see if the flow scale passed or failed, so that you know if you can use it for sampling and observer catch estimates. Record the results in the ATLAS Flow Scale Test Form (see NPOP manual for more details on entering this data in ATLAS). Some vessels may do "mini-flowscale tests" during the day. You are only required to be present for the daily 400kg test.

If the flow scale fails the test, it may be re-tested as many times as the crew wishes. The scale may *not* be relied on as a source for total catch weight until it has passed the daily test. If total catch is weighed on a flow scale that did not pass the test, do not use that weight as the Observer Estimate. Report only the vessel estimate, leave the observer estimate blank, and notify your in-season advisor. If the flow scale fails, the captain decides whether to continue fishing. If the vessel continues to fish, sample for species composition using the MCP scale (if it has passed its test). Your sample sizes will be limited by the fact that you must



weigh the entire sample on the MCP scale. Notify your in-season advisor, and document the situation in your logbook. Do not refuse to sample, or tell the vessel they cannot fish, if the flow scale is not functioning. The flow scale display panel should be sealed. If you suspect the seal is broken, or that someone is tampering with the flow scale, talk to the captain, and document this fully in your logbook.

### **Ensuring Accurate Weights**

Everything in the catch must pass over the flow scale to be weighed. Document all situations when not everything is weighed, such as large organisms removed on deck or organisms removed in the factory prior to the flow scale. Add these weights, or estimated weights, to the flow scale weight in order to calculate the correct observer catch estimate. Individuals of certain species, such as ragfish, may fit through the live tank doors and make it into the factory, but may be too large or bulky to go up the incline belt. Direct crewmembers to pull them off prior to the incline and place them on the belt that feeds to the flow scale so their weight is included in the total haul weight. If an organism is too large to go over the flow scale, cut it up into pieces and weigh it on the MCP scale, if possible. If you cannot weigh it on the MCP scale, record its length and estimated weight. Add the organism's weight to your total sample weight and to the flow scale weight to get the observer catch estimate. If this occurs during a non-sample period, add the estimated weight to the flow scale weight to obtain your observer catch estimate, but do not include it in your species composition sample data, or discard estimate. Occasionally, weight will be added to the flow scale after all the fish have been run out of the tank (e.g., water sprayed over flow scale to clean it). If you sampled the second half and are confident all the fish were run out before you recorded the haul end weight, use the weight you recorded for your observer catch estimate.

### **Presorted Organisms**

Although presorting is never legal, occasionally very large animals are sorted on deck to prevent them from entering the factory or live tanks. When a large organism (e.g. salmon shark) is presorted, the observer must be informed and allowed access to the organism for identification and sampling.

Documenting presorted organisms does not validate the illegal practice of presorting. Observers should remind the deck crew that medium-sized organisms, such as ragfish or skates, *should not be presorted on deck*.

If a very large organism is excluded on deck or removed from the live tank before your sample, it never had the chance to fall in your species composition sample. Record it as a presorted sample, enter the number of organisms and use the appropriate length/weight table, or estimate the weight. Measure and record the length, if possible. Add the estimated weight to the flow scale weight to obtain the observer catch estimate for that haul and enter the observer catch estimate as the sample size for the presorted sample.



### **Length-to-Weight Tables for Large Organisms**

Length-to-weight tables for salmon sharks, Pacific sleeper sharks, Pacific halibut, big skates, and longnose skates are in Appendix P-R in the NPOP manual. For salmon sharks and Pacific sleeper sharks, the length to weight tables use the total natural length – tip of snout to posterior margin of the upper caudal-fin lobe, with the fin in its natural position. For other species of large presorted sharks, cut up and weigh them or make a visual estimate of the weight.





### **Set Up a Random Sample Design**

1. Define the population: *every fish in the haul*
2. Define your sample units: *50% of the haul or smaller units for high bycatch hauls*
3. Number all of the sample units
4. Randomly select units to sample: *use RNT, dice, etc.*

### **Random Number Table**

#### ***Excerpted from NPOP manual: How to Use the Random Number Table***

To use the random number table, enter the table at a random point. The easiest way to do this is by closing your eyes and placing your finger on the table. The column and row nearest your finger is the starting point. Determine how many digits you will use in the row (e.g. if you need numbers between 1 and 25, use two digits in the row). Decide in which direction you will move through the table. Then proceed in any direction through the table (even diagonally), recording appropriate numbers and skipping numbers too high or repeated, until you have enough random numbers. You should decide on a direction and enter the table at a different random starting point every time you use it. *For example*, if you need to choose three numbers between 1 and 15, you could enter the table by placing your finger on the table to choose a column and row. Your criterion is two digit numbers between 01 and 15 (inclusive). For this example, you decided to work up the column from your starting point. As you move up the column, the first number you encounter is 14. This is a two-digit number between 01 and 15; it fits the criterion, so you write it down. The next number is 09; it also fits the criterion, so you write it down. The next number is 58 and does not fit the criterion so you skip this number. Keep moving up the column, skipping the numbers that do not fit the criterion, until you have chosen all the numbers you need.

### **Random Sample Table**

You and your partner will set up opposite work shifts and sample every haul. In the event that one observer gets sick or injured and is unable to sample, contact your in-season advisor and a decision will be made as to whether the random sample table should be used. Generally, if the sickness is expected to last only a day or two, then the well observer will continue to sample during their normal shift. If the sickness might last longer than two days, then the random sample table needs to be used so that the samples are not all coming from the same time period. Always notify your contractor and the A-SHOP of any injury or illness.

## **Species Composition Sampling**

The hake fishery is managed using your observer data, therefore it is vital that the data be both randomly collected and of high quality. Sampling 50% of the haul for species composition is the norm in the hake fishery, except for hauls with unusually high levels of species diversity. Implementing a random sample design is straightforward since all vessels have flow scales. Either estimate the size of the haul yourself, or ask the captain or factory manager for their estimate. Make sure your sample design allows all organisms in the haul an equal opportunity to be sampled.

---

The A-SHOP does not require three distinct samples from each haul, which differs from NPOP requirements.

---

---

Please do all you can to avoid small samples for hauls with *species of concern* present.

---

The vessels are concerned with bycatch of species of concern and are interested in working closely with the observers to ensure that the largest and most accurate samples are taken. This requires cooperation between the observer, the person controlling the belts, and any sorters who might be assisting at the belt. You must be able to account for every piece of bycatch for a sample to be valid.

To minimize incline belt bias, and maintain discrete start and stop points for your sample(s), have a crewmember close the live tank doors and run out all the fish on the belts prior to the flow scale at the start and end of your sample(s).

If you cannot see and collect all species for which you are sampling, you must either reduce your sample size, or work with the vessel crew to achieve your sampling goal. *Keep sampling options in mind when setting up your sample design.*

**Sampling Options**

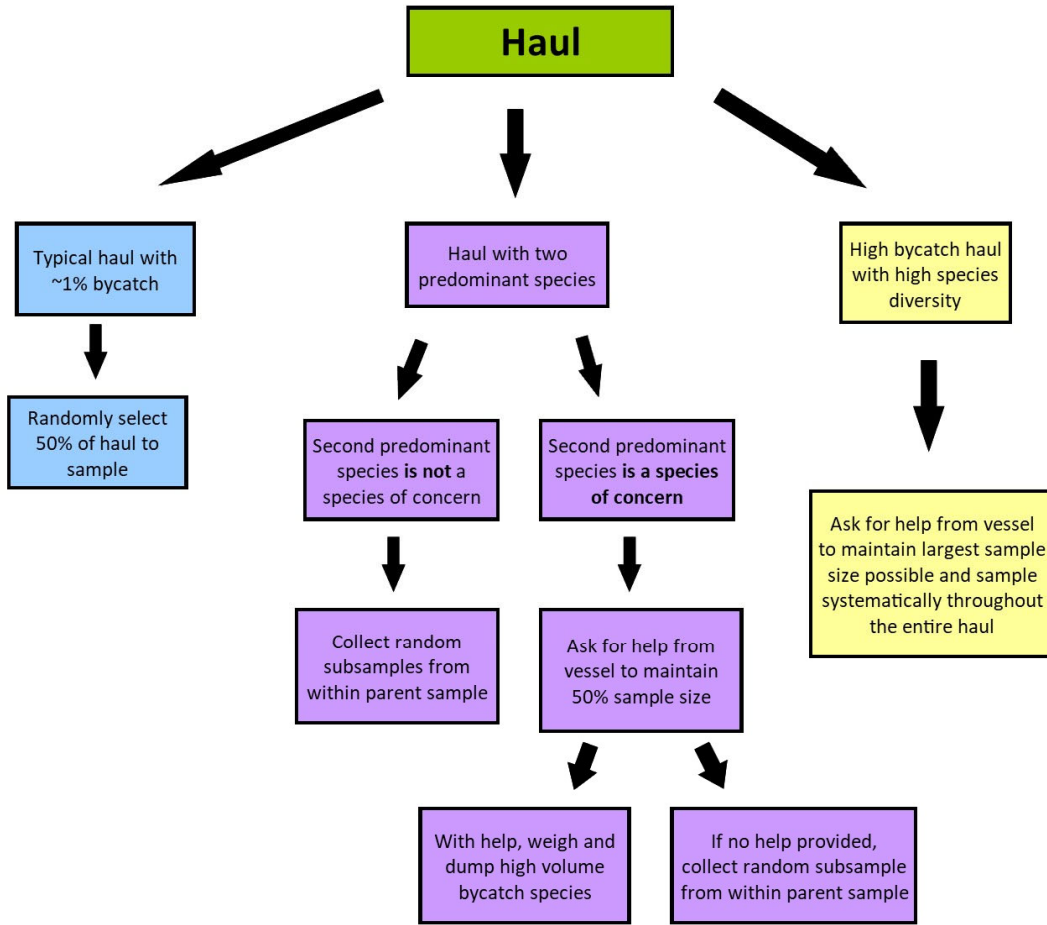

**Figure 2 A-SHOP sampling flow chart**

For a typical low bycatch haul, divide the weight into two equal parts and randomly select which half to sample for species composition (see Figure 3). For an illustration, see Appendix E1. Typical Low Bycatch Decksheet Example.

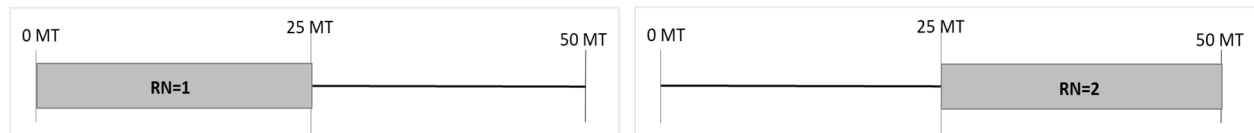
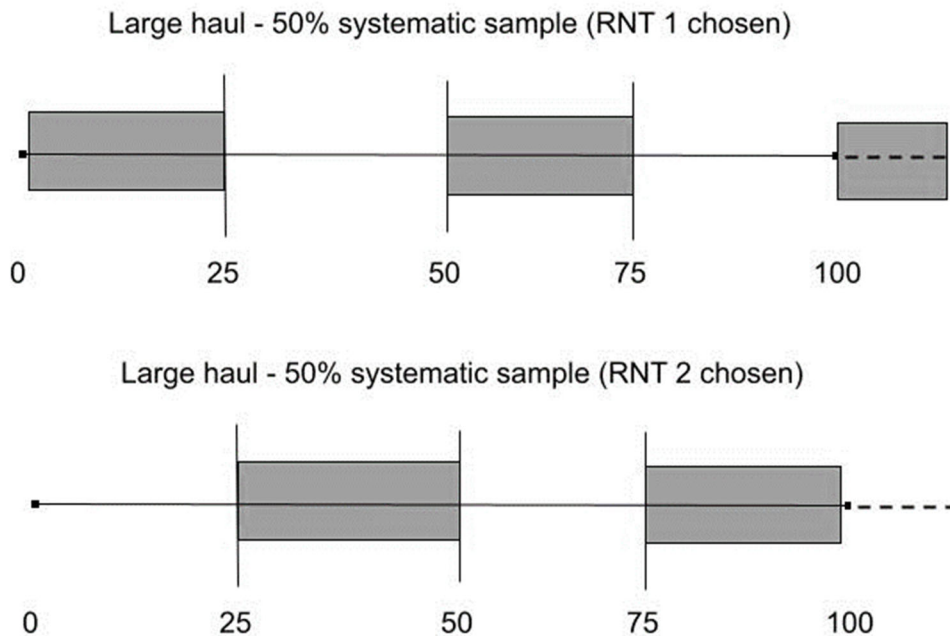

**Figure 3 Sample Design Schematic - simple random example**

Your sample design is based on an estimate and your goal for a typical haul is 50%. If you are sampling the first half, start at the beginning of the haul and stop at the estimated halfway point. If you are sampling the second half, start at the estimated halfway point and sample until the end of the haul (i.e., all tanks are empty). Your sample weight is the weight you actually sampled. For small, clean hauls (e.g. <15 tons), you may be able to census the haul.

If you are on a vessel that pulls up codends with large catches (>75 MT), consider employing a random systematic sample design to break up the sampling effort.

**Example:** 100 MT haul with little bycatch, break into four units of 25 MT, randomly choose 1 or 2 to systematically sample. If “1” is chosen, sample from 0-25 MT, take off 25-50, sample from 50-75 MT, take off 75-100, if haul goes past 100 MT, sample from 100 up to 125 MT. If “2” is chosen, sample from 25-50 MT, take off 50-75, sample from 75-100 MT (see Figure 4).



**Figure 4 Sample Design Schematic - systematic random, low bycatch, large haul example**



### **Subsampling For Two Predominant Species**

When there are two predominant species in a haul, subsampling is a good option to maintain large sample sizes and minimize workload. The two predominant species in the parent sample must be identified to the *species level*, not a species group (i.e. brown cat sharks and spiny dogfish cannot be lumped under *shark unid.*). Everything that lands in your subsample is documented in the species composition data for that subsample. If you subsample for hake and spiny dogfish, and get hake, spiny dogfish, and widow rockfish in your subsample, you record hake, spiny dogfish, and widow rockfish in the species composition data for that subsample.

The size of your subsamples will depend upon the predominance of the two species. Use random systematic subsampling to capture an accurate ratio of the two species. Use either the flow scale or 2-3 baskets to take subsamples from three parts of the species composition sample.

### **Subsample Option 1: “*The flow scale is your friend*” / large (500 – 1,000 kg) subsamples using the flow scale**

**Example:** Richard estimates the bag is ~48 MT and randomly selects the second half. He sees a fair amount of yellowtail rockfish mixed in with hake during the dump. With the goal of 3 subsamples, he divides the sample size of 24 tons by 3 to get intervals of 8 tons. He randomly selects ‘4’ to be the start of his first subsample. During his sample, he lets the yellowtail and hake go by and collects all other bycatch. At 27 tons (the beginning of the 4<sup>th</sup> unit of his sample), he has the belts prior to the flow scale cleared of fish and records the flow scale weight. He starts the belts and pulls everything but hake off the sorting belt. After about a ton, he clears the belts again and records the flow scale weight to get his first subsample weight, then continues with his sample.



The bag is actually 52 MT so he maintains his sample design until the end of the haul, collecting his ~1 MT subsamples at 35, 43 and 51 MT (see Figure 5). For an illustration, see Appendix E2. Flow Scale Subsampling Decksheet Example.

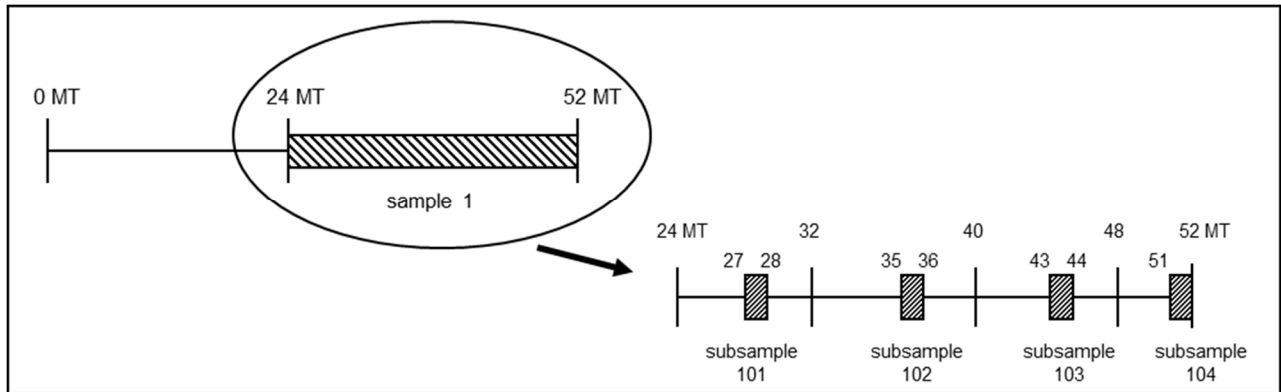

Figure 5 “The flow scale is your friend” subsampling example

### Subsample Option 2: Use baskets

**Example:** Barbara estimates the bag is ~60 MT and randomly selects the first half. During the bag dump, she sees many spiny dogfish mixed in with the hake and little other bycatch. She breaks her 30-ton sample into 3 intervals of 10 tons and randomly selects ‘1’ to be the start of her first subsample. During her sample, she lets the dogfish and hake go by and collects all other bycatch. She collects 3 baskets each at ~0 tons (during the first ton), ~10 tons and ~20 tons for her 3 subsamples (see Figure 6). For an illustration, see Appendix E3. Basket Subsampling Decksheet Example.

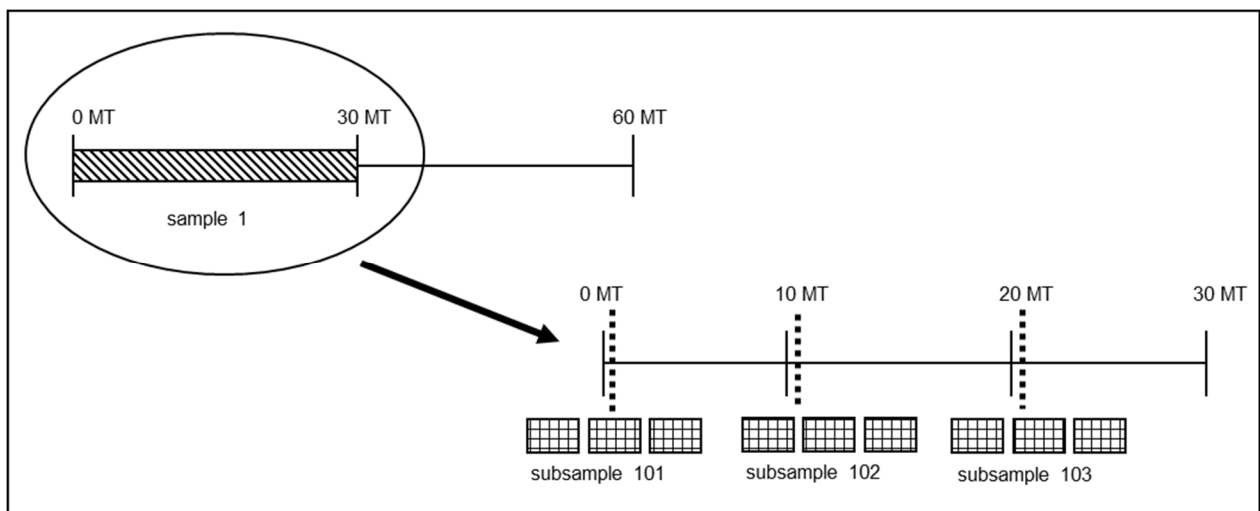

Figure 6 “Use baskets” subsample example

If the catch is so diverse that you have more than two predominant species or cannot account for all other bycatch from within your sample, you should not be subsampling.

### **High Bycatch Sampling**

For hauls with high species diversity for which you cannot sample 50%, set up a random systematic sample frame from the entire haul. Design your sample frame with the goal of getting a minimum of 600kg (more is better!) total sample weight. Collecting small systematic samples in your baskets should be the option of last resort.

On rare occasions, you may not be able to sample the entire originally chosen sample unit or be able to follow your intended sample design. If you find yourself in this situation, continue to systematically sample the haul. Document the reasons in your daily notes.

If you are not be able to collect the entire originally chosen sampling unit, you will have to stop your sample collection sometime within one of your randomly chosen units. This situation should be avoided with a well-planned sample design. However, if you are forced to stop collecting a sample before the entire sample has been collected, follow these guidelines:

- If you are collecting five systematic samples and the first sample must be reduced in size from the original design, make all subsequent samples the same size as that first smaller than intended sample. Determine a sample size that is feasible for the remaining units left to be sampled. A good guideline for this is to try to make the new sample size consistent with the first sample that you had to reduce in size. For these smaller subsequent samples, use the start weight laid out in your original sample design.
- If you are collecting five systematic samples and the first sample unit is sampled without incident, but the second sample must be abandoned at some point due to high diversity, the remaining samples should follow the original intended unit size. If that is not possible, attempt to keep sample 3, 4, and 5 of consistent size with sample 2.

In order to achieve similar sample sizes over the course of one sampled haul, tailor the sample size to accommodate the most diverse portion of the catch. Establish a unit size that you know you can sample consistently through the entire haul. If you are constantly sampling less than your intended unit, you must come up with a new unit size, frame, and possibly an entirely new sample design. Contact your inseason advisor for advice and if questions remain.

Always ask the crew for help on high diversity hauls.

**Example:** Maya sees a fair amount of shortbelly rockfish, jack mackerel, and Pacific mackerel visible during the dump of an estimated 60 MT haul. She coordinates with the back line crew to run fish slowly while she’s sampling and decides she can sample systematically for 1 MT, then take 9 MT off to work up the sample. She breaks the haul into 10 MT units, chooses a random start point, and then samples systematically throughout the haul (see Figure 7). For an illustration, see Appendix E4. High Bycatch Systematic Sampling Decksheet Example.

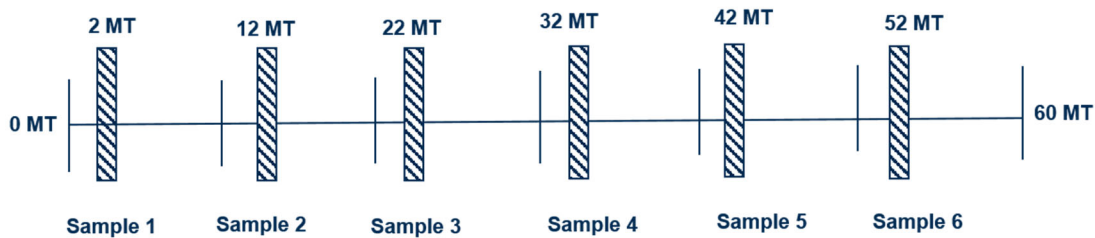

**Figure 7 Sample Design Schematic - systematic random, high bycatch example**

To help set up your sample design, refer to the Sample Design Schematics in the Wet Manual. Refer to the priority list while sampling. For high bycatch hauls, you should drop lower priority tasks (e.g. biospecimen samples) in order to maintain the largest sample size possible.

**Average Weight Samples** (referred to as “subset samples” in the NPOP manual)

Randomly collect an average weight sample of approximately 50 hake from every haul, and record the weight and count of fish. The average weight sample is a logical place to get your biospecimen fish.

---

Samples from a trawl fishery are weighed samples, therefore, every organism must have a weight.

---

Minimize your workload by collecting average weight samples for abundant bycatch species. Do not waste your time counting high abundance species. Count and weigh approximately 50 randomly collected individuals. Record the weight for the remaining individuals of that species with a 0 count (i.e. “weigh and dump”).

Options for abundant bycatch average weight collection include choosing a random basket or two once species composition sampling is complete, or choosing a random section of the sample to set aside the next ~50 individuals of that species. Average weights are collected *once per haul*, not per sample. For an illustration, see Appendix E. Decksheet Examples

## **Percent Retained and Estimated Discard Weight**

Estimate percent retained for each species in your species composition sample. These estimates should reflect what the vessel does, or intends to do. Percent retained data is important to resource managers and should be as accurate as possible. When disposing of your sample, mimic what the vessel does. Fish specimens that you collect should *not* be reflected in your estimate of percent retained. If necessary, ask for help getting your bycatch onto the correct belt.

The time spent on this information should be minimal and obtaining an Estimated Discard Weight should only take a few moments. Record Estimated Discard Weight in kilograms on the OHF for each haul. Ask the vessel crew which belts are going to fish meal (retained) and which are going over-board (discard) so that you can accurately estimate these values.

### **Estimated Discard Weight Options:**

#### 1. **Typical haul:**

Visually estimate how many baskets of discards from species composition sample and multiply by 2.

- *50% sample example:* Sampled 25 MT of 50 MT bag. Three ~40kg baskets of bycatch discarded during sample. Estimated Discard Weight =  $(3 \times 40 \text{ kg}) \times 2 = 240 \text{ kg}$ .

#### 2. **High bycatch hauls – subsampling for two predominant species or multiple small samples:**

Visually estimate discard amount and multiply by proportion of bycatch.

- *Subsampling example:* Looking at the bag dump, it looks like about 10% is spiny dogfish mixed in with hake. Multiply 60 MT vessel estimate by 0.10 to get Estimated Discard Weight = 6,000 kg.
- *High bycatch example:* There's lots of jack mackerel, Pacific mackerel, and American shad visible in the tanks. It looks like about 20% bycatch mixed in with the hake. Multiply 50 MT vessel estimate by 0.20 to get Estimated Discard Weight = 10,000 kg.

3. **For mothership hauls with catcher-vessel discards**

Option 1 or 2 + Catcher Vessel Discards = Estimated Discard Weight

4. **For hauls with pre-sorted organisms**

Option 1 or 2 + Weight of Presorted Organism(s) = Estimated Discard Weight

5. **For hauls where fish spilled overboard (bag overflow, blowout, etc.)**

Option 1 or 2 + Visual Estimate of Spillage = Estimated Discard Weight

**Mothership Catcher Vessel Discard Accounting**

Mothership observer catch estimates and discard data must include catcher vessel (CV) discards. Most catcher vessels are equipped with a camera system for electronic monitoring (EM), while a couple will have a West Coast Groundfish Observer Program observer onboard. A discard estimate of any at-sea discards before the point of delivery will be transmitted to the mothership captain.

**Protocols:**

1. Ask the mothership captain where CV discard data are recorded.
2. Determine which weight units are used (CV discards may be in pounds!)
  - To convert the discard weight to kg, use: 1 lb. = 0.4536 kg or 1 MT = 1000 kg.
3. Document all Observer Catch Estimate and discard calculations in the “Mothership Catch Estimate and Discard Calculations” section of the logbook (*see Figure 8 for example*).
4. Add the CV discard weight:
  - To the flow scale weight to get the total *Observer Catch Estimate* on the OHF.
  - To the mothership discard weight to get the total *Estimated Discard Weight* on the OHF (see discard estimation option 3 for calculation).
5. Calculate the percent of catch delivered to determine if percent retained needs to be adjusted.
  - Determine the percent of catch delivered by *dividing the delivered catch weight (flow scale weight + large items = [B]) by the final observer estimate ([B] + CV discards = [F])*.
  - If the percent of catch delivered is <100%, adjust the percent retained for all species in the species composition sample on the decksheets and in ATLAS by multiplying the original percent retained by the percent of catch delivered (*see Figure 9 for example*).

Mothership Vessel Name Starlord

Haul #	Catcher Vessel Name	Flowscale End - Start = Flowscale Weight (kg)	[A] + Large Items Not Weighed on Flowscale (kg)	CV discard estimate (lb)	CV discards (kg) = [C] x 0.4536 kg/lb	MS discards <sample + pre-sort> (kg)	record on OHF	record on OHF	% of catch delivered = ([B] / [F]) x 100
							Estimated Discard Weight (kg) = [D] + [E]	Observer Catch Estimate (kg) = [B] + [D]	
		[A]	[B]	[C]	[D]	[E]		[F]	
11	Poseidon	49075	49075	500	227	89	316	49302	100%
12	Grant	38468	38468	0	0	107	107	38468	100%
13	Amelia Marie	41357	41477	5000	2268	273	2541	43745	95%

Figure 8 Mothership Catch Estimate and Discard Calculations section of logbook

**A-SHOP Deck Form**

Date	Lead Cruise	Permit	Haul #	Sampled by	Page <u>1</u> of <u>      </u> for Vessel
9-30-21	21212	4321	1	21212	Page <u>1</u> of <u>1</u> for Haul
Sample #	Subsample #	Sample Size	Presorted?		
1		20786 kgs	Y (N)		

Species	#	Weight	% ret.	Notes
-----Keypunch-----	184	20786	X	~40 MT RNT = 102
Hake	0	20629.70	100	95
Hake	59	29.42	100	95
Squid	89	38.90	0	FS end: 41357
Squid	0	25.75	0	FS start: 20571
Jack mack	14	23.99	50	20786 discards
yellowtail	22	38.24	100	64.65 + (23.99 x 1.05) x 41357 / 20786 = 152.50 kg

Figure 9 Adjusted percent retained, due to CV discards, recorded on decksheet

If you census a haul that has CV discards, please record the sample design as code 6.

### Species ID Forms

Each observer must complete a species ID form for every new species encountered during hake deployments. Correct species identification is the cornerstone of observer data. Species ID forms and photos are documents that verify to the program, and to the fishery participants, that each observer is able to correctly identify species. The A-SHOP will provide you with a list of the verified species ID forms you completed for the A-SHOP and the NPOP.

Complete a species ID form for each new species you encounter in your sample, with the fish in hand, which you keyed out yourself.

Complete the form with sufficient detail to convey clearly that the species was identified correctly.

Identify species only to the level to which you are confident. Photograph and collect any unknown fish and record as “fish unid” in the data.



An A-SHOP camera is issued to each pair of observers. Pictures are a required element to your species identification verification, so please take a picture of each new species you see and any rare and usual species. You no longer have to complete the drawing section on your species ID form, instead your photos will fulfill this requirement. Upload photos regularly (e.g. every 2 days) to ensure they are not lost and to keep track of proper labeling. Photos must be labeled and of sufficient quality (full body and not blurry) to easily determine it is the correct species. Please save your photos onto a thumb drive in an electronic folder labeled with your name, cruise number, and vessel name. (e.g. folder name: *Fiona Staples\_79342\_Saga*). Do not use sub-folders, simply label individual photos in folder (e.g. file names: *Canary1, Canary2, POP, Chinook1\_tail, Chinook1\_mouth, Chinook1\_body*). Photos must be submitted in JPEG format.

**Prohibited Species**

SPECIES	PROHIBITED	TAKE LENGTHS
Salmonids (all species)	YES	YES
Pacific halibut	YES	YES + viability
Dungeness crab	YES	NO
Herring	NO	NO
Tanner crab	NO	NO
King Crab	NO	NO

All salmonids, Pacific halibut, and Dungeness crab are prohibited species in the hake fishery. Prohibited species are listed in federal regulations. While vessels may decide to not allow retention of certain species as the season progresses, this does not make them prohibited. Herring, tanner crabs, and king crabs are *not* prohibited species. Collect viabilities from Pacific halibut at the point of discard.

**Protected Fish Species Sampling**

Some salmon, sturgeon, and eulachon populations on the West Coast are protected under the Endangered Species Act (ESA). When salmon or green sturgeon are encountered in your sample, additional biological sampling is required.

## **Salmon**

Salmon is of particular concern in the hake fishery due to declining populations along the West Coast. Salmon bycatch is managed by numbers of fish, not by weight.



The vessel may want haul-by-

haul salmon numbers from you so they can attempt to reduce incidental take. There is no Salmon Retention program in the hake fishery, so do not enter any data in that section of ATLAS.

Identify, weigh, and count every salmon in your species composition sample. If you are unable to do this, you must either ask for help to maintain your sample size or reduce your sample size. Because salmon bycatch is such a sensitive issue on the West Coast, the vessel should be willing to help you maintain your sample size, so ask for help!

In the hake fishery, you *do not* record salmon by sex in your species composition sample. Simply record count and weight by species, then set them aside for the biological sampling as outlined below.

Be careful with salmon identification. Salmon off the West Coast can be challenging to identify, and the typical characteristics for identification may be faint or absent. If you are uncertain of the identification, freeze that salmon and bring it back with you. Atlantic salmon and steelhead trout are rarely seen in this fishery; if you do encounter either, bring back the whole fish.

### **Salmon ID verification protocol (“2 plus 3”):**

For each salmon species you encounter in your species composition sample, each observer will:

- Collect *the first 2 whole specimens*, of each species
- Take *photographs of the next 3 specimens*, of each species
  - Take 3 photos for each fish - full body, mouth, and tail

These specimens serve to verify observers’ ability to identify salmon correctly, as well as provide the A-SHOP, WCGOP, and NPOP with salmon specimens for fish training. This requirement is independent of the species ID form (i.e. you need to collect specimens, even if you already have a verified ID form). It is unlikely that each observer will have more than 6 specimens apiece. As with all whole fish specimens, include a specimen collection label with the whole salmon. Large plastic bags are provided with your A-SHOP gear to facilitate salmon specimen collection.

## Salmon Biospecimen Sampling

Salmon Sampling	Sex / Length	Weight	Adipose Fin	Scan for CWT	Fin Clip	Freeze 2 Whole	3 Photos of 3 Fish
Chinook	X	X	X	X	X	X	X
Coho	X	X	X	X	X	X	X
Pink	X					X	X
Chum	X					X	X
Sockeye	X					X	X
Steelhead / Atlantic	X					X	X

## Coded-Wire Tag Sampling

Some salmon are tagged with coded-wire tags (CWTs).

These are tiny metal tags inserted into the snouts of juveniles. In the past, when a CWT was inserted, the adipose fin was clipped to indicate the presence of a tag. However, West Coast hatcheries now clip the adipose fin on all fish they release; therefore, electronic means must be used to determine if a tag is present. Additionally, both Chinook and coho sometimes have double index tags (DITs) which means they have CWTs, but the adipose fin has purposely *not* been clipped.

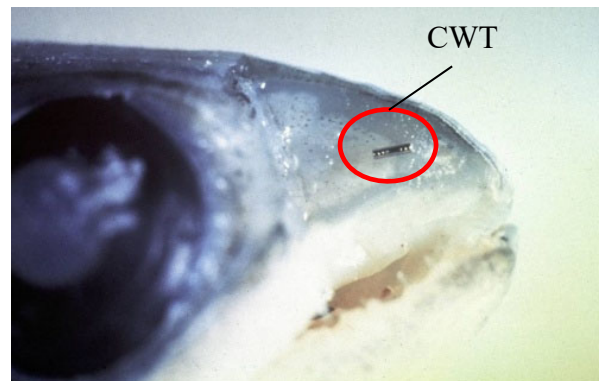

Each Chinook and coho scanned for a CWT must be recorded on the A-SHOP Salmon Sampling Deck Form, whether they have a CWT or not. This data allows us to calculate the mark-recapture rate and is reported to a regional database with all other CWT recoveries. One metal detecting wand is issued to each observer-pair to determine the presence of CWTs.

### **Sampling Details:**

*This project applies to Chinook and coho salmon.*

1. Scan all Chinook and coho in the sample for the presence of CWTs.
  - Pass the wand, in direct contact with the fish, along the exterior of the entire upper snout (*see Figure 10*).



Figure 10  
CWT presence

2. Collect all tagged snouts.
  - Cut straight down directly behind the eye, to collect the upper snout only.
  - Place the snout inside a barcoded zip-top bag (*see Figure 11*).
  - Record the barcode number in the ‘Snout barcode’ column on the A-SHOP Salmon Sampling Deck Form (*see Figure 12*).
  - Store the snouts in a clearly labeled bag in the freezer, to ensure that all return to debriefing with you.
  - If either of your first two salmon is CWT-tagged, collect the snout as described above and then collect the next whole specimen for ID verification.



**Figure 11 Salmon snout in barcoded zip-top bag**

3. Record data for every Chinook and coho scanned for CWTs, *even those not tagged*, on the A-SHOP Salmon Sampling Deck Form (*see Figure 12*).

### **Notes about salmon wands:**

- Beware of nearby metal that can set the wand off. Your cellphone, wristwatch, belly button ring, or nearby metal in the factory may cause false positives.
- These wands are *very expensive*. Please take good care of them. The wand is water-resistant, not waterproof. Store it in a clean, dry, and safe location. If the wand is not functioning properly (i.e. weak or prolonged sounds), try changing the battery. There is a spare 9-volt battery in the wand case. *If the wand stops working, contact your in-season advisor immediately for directions on how to sample for CWTs without a wand.*
- Wands are assigned to observers, not to vessels. Bring it with you when you disembark a vessel, even if other observers are replacing you on that vessel.

### **Chinook and Coho Genetic Sampling**

The goal of this data collection is to obtain an estimate of the genetic stock composition of Chinook and coho salmon bycatch and to understand the spatial and temporal distribution of these distinct stocks. This information helps managers evaluate the impacts on specific salmon stocks, including those listed as threatened or endangered under the Endangered Species Act.

### **Sampling Details:**

***This project applies to Chinook and coho salmon.***

1. Collect genetic samples (fin clips) from all Chinook and coho salmon inside the sample.

- Snip off a small piece of pectoral fin (about the size of your pinky fingernail) with scissors.

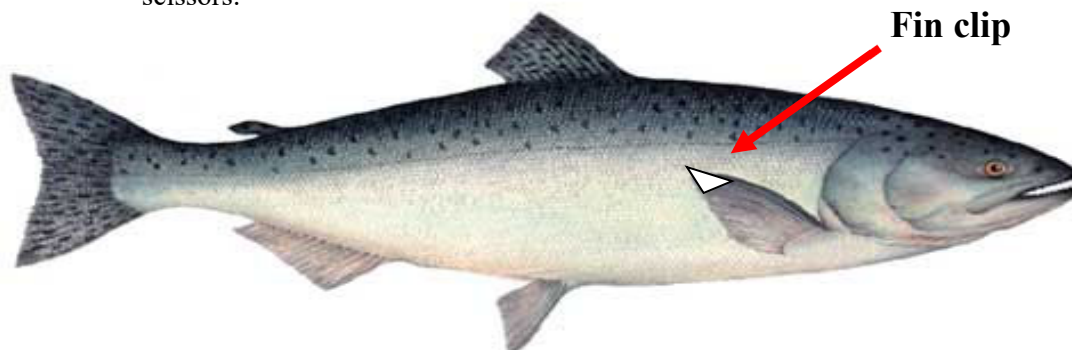

2. Place fin clip flat on paper, fold paper over to maintain a layer of paper between the fin clip and the envelope, and seal the envelope.



3. Record on envelope: Lead Cruise, Haul, and *Snout Barcode*, if CWT tagged. For coho samples, cross out “Chinook” and write “coho” on envelope.
4. Record all data on A-SHOP Salmon Sampling Deck Form (*see Figure 12*).

Keep the envelopes clean. Slime or blood from other fish can contaminate samples. Rinse scissors and forceps in salt or fresh water between sample collections. Samples need to dry out as fast as possible. The longer they stay wet, the more the tissue breaks down.

### Fin Clip Storage at the End of the Day

Allow fin clips to dry out, they should not be frozen. Do not put samples in plastic containers, as they will not dry. Bundle by species once dry and store at room temperature, in large manila envelopes issued with your A-SHOP gear.

### Salmon Subsampling

The vast majority of salmon encountered in the hake fishery are Chinook salmon. *All Chinook in your species composition sample should be sampled for both CWTs and genetics.* If you are overwhelmed with Chinook salmon in a particular haul and are not able to sample all of them for both CWTs and

genetics, select a random subsample with a goal of 25 fish /per haul. Chinook biological sampling includes both genetics and CWT sampling, so the subsampled Chinook are sampled for both genetics and CWTs. Indicate that you subsampled on the Salmon Sampling deck form (circle “Yes” next to “Subsampled for Chinook genetics and CWTs?”) and describe your subsampling method. Sample all of the relatively few coho you may see for CWTs and genetics.

**Example:** 2 coho and 4 baskets of Chinook are in the species composition sample. Randomly select 3 of the 4 baskets of Chinook to subsample for both CWTs and genetics. Sample the 2 coho for CWTs and genetics. *Note: Hauls with this level of Chinook bycatch are rare.*

**Using the Salmon Sampling Deck Form**

Record all CWT and genetics data on the Salmon Sampling deck form, which is waterproof and designed for use in the factory. Number pages separately - start with 1 and enter the total number at the end of your deployment.

**A-SHOP SALMON Sampling Deck Form**

Page 5 of \_\_\_\_\_

record species comp data on Deck Form

record all *Chinook and coho* SALMON SPECIMEN data here\*

*\*it's waterproof for a reason*

Lead Cruise	Permit	Haul	Sample	Vessel Name
97531	1098	17	1	Merluzzo

Subsampled for Chinook genetics and CWTs? NO Yes if Yes, method: \_\_\_\_\_

	Species	Sex	Length (cm)	ATLAS Specimen #	Weight (kg)	Genetics barcode	Snout barcode (if CWT-tagged)	Adipose present?
1	Chinook	F	47	174	1.73	1709337	—	Y
2	Chinook	M	53	175	1.98	1709338	—	Y
3	Chinook	F	52	176	1.87	1709339	809611	N
4	Chinook	F	61	177	2.83	1709340	—	N
5								
6	coho	M	49	178	1.82	1709341	—	Y

**Figure 12 Example of A-SHOP Salmon Sampling Deck Form**



## Sturgeon

If you encounter a sturgeon, please follow the sampling protocol found in your species ID guide at the end of the Bony Fishes Key. The directions explain how to collect biological information and a genetic sample from each fish. Green sturgeons are quite rare in this fishery; only two have been caught in the last fifteen years.

### **Biospecimen Sampling**

Additional biological data for hake and other managed species in the hake fishery are used by stock assessors and resource managers to evaluate and assess population dynamics. This biospecimen data includes sex, lengths, individual weights, age structures, and genetics. All biospecimen samples must be collected randomly, from inside the species composition sample. When subsampling for two predominant species, biospecimen fish can come from either the sample or the subsamples, as long as they are randomly selected. For a review of sample design and methods, refer to Chapter 13 of the NPOP manual. If you are having difficulty coming up with a random method for collecting fish for biospecimen

---

Remember! Record the individual weight of age-structure fish.

---

samples or if you are not sure if your method is truly random, contact your in-season advisor for help. It is acceptable to collect a single otolith and/or the two halves of an otolith with a single, clean break. When entering biospecimen data, you will typically use sample design codes 6 (simple random) or 10 (census). If you think you should use a different code, contact your in-season advisor.

For hake, the randomly selected average weight sample is a logical place to get your biospecimen sample. On the rare occasion that your average weight sample for hake is collected opportunistically (you must collect an average weight sample from every haul), do not collect hake biospecimen data from that haul.

The data collected from rockfish and other species in the hake fishery is invaluable to stock assessors. Biological data collected by A-SHOP observers is used in 14 different stock assessments. Balance the collection of this important data with your other sampling duties by *following the priority list*.

### **Biospecimen Sampling Protocols**

Collect biospecimen data in order of species priority, as time allows. The protocols are broken up into tiers, by importance of species. Tier 1 is the highest priority – collect biospecimen data from these species whenever they are present in the haul. Tier 2 species are the second highest priority and Tier 3 lower priority. The goal is to collect biospecimen data for all species in Tier 1,

---

Refer to the Wet Manual for the specific protocols for all sampling priorities and biospecimen data collections.

---

the top 2 priority species in Tier 2, and the top species in Tier 3, time permitting! Biospecimen sampling is lower priority than species composition and salmon sampling. On high bycatch hauls, you may not be able to sample for biospecimens in order to complete higher priority sampling (and that's OK!)

<b>Species</b>	<b>Sex-Lengths</b>	<b>Collect Weight + Age-Structure (+ Fin Clip)</b>
<b>Tier 1</b>		
<b>Hake</b>	10	4 every 3rd haul
<b>Shortbelly</b>	20	2
<b>Yelloweye</b>	<i>collect the whole fish - up to 5 / observer</i>	
<b>Tier 2</b>		
<b>Canary</b>	20	10 (+ 1 fin clip)
<b>POP</b>	20	1
<b>Bocaccio</b>	20	2
<b>Darkblotched</b>	20	1
<b>Rougheye</b>	20	2 (+ 2 fin clips)
<b>Widow</b>	20	1
<b>Yellowtail</b>	20	2
<b>Tier 3</b>		
<b>Sablefish</b>	10	n/a
<b>Spiny Dogfish</b>	10	1 [2 <sup>nd</sup> dorsal spine]

Predicting when and how many biospecimen sample species you will see is impossible. Ideally, you would set aside all that are in your sample and then randomly choose your biospecimen data fish. However, this may be difficult if you have more than a few baskets of fish. In those cases, you will need to use other means of randomization. One method would be to break the haul into even units (fourths, thirds, tons) and randomly choose a point within the sample to start the collection, collecting the next 10-20 individuals of that species as your biospecimen sample.

**Example:** You are sampling the first half of a 60 MT haul with a fair number of POP, and a few darkblotched, and widow. You break your 30 MT sample into 3 units of 10 MT and randomly select the third unit. Starting at 20 MT, you set aside the first 20 POP and retain the few darkblotched, for biospecimen sampling, since they are a higher priority than widow.

Keep otoliths organized during your deployment. Use the permanent marker and rubber bands in your hake gear. Labeling the vials with species and haul number (e.g. “RE H13” for a roughey from Haul #13) will make for a smoother debriefing. The vials will *not* be hydrated during debriefing as they are shipped dry to age readers. In addition, our age readers will be testing a new infrared scanning machine on otoliths over the next few years, so it is especially important that otoliths are clean and dried at-sea.



Inspect otoliths closely when organizing and re-clean if necessary. Please do not enter otolith barcodes into the Scanned Ages section of ATLAS at-sea. Scanning them with a barcode scanner post-deployment ensures the numbers are entered correctly, and is part of the debriefing data quality control process.

### **Genetics**

As a tool to inform resource management, there is an ongoing interest in genetic data from species that occur in the hake fishery. Pectoral fin clips (identical to Chinook and coho genetics fin clips) are collected from several species.

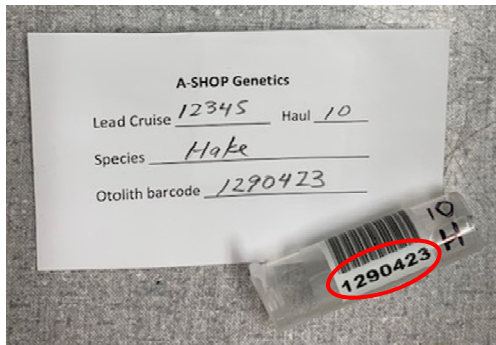

**Figure 13 Genetics envelope with corresponding otolith vial**

Fin clips are collected only from otolith fish. Randomly select an otolith fish from which to collect a pectoral fin clip. White genetic collection envelopes are included with your A-SHOP gear for rockfish fin clips. Record the lead cruise number, haul number, species, and *otolith barcode* number on the envelope (see Figure 13).

Lengths must have an associated sex to be useful for stock assessment. If you are unable to determine the sex of a specific individual, record it as “unknown”. Rockfish and sablefish can be more difficult to sex than other round fish. Information on how to sex fish is included in the Wet Manual.

## **Spiny Dogfish Protocols**

Spiny dogfish are a common bycatch species in the hake fishery. Age data indicates that one dogfish spine collected from the hake fishery, from a 100 cm female, was 88 years old. The second dorsal spine on dogfish are used to determine the age. You will be issued 50 barcoded bags with your hake gear. Once the 50 bags have been used, continue to collect sex/lengths only.

To determine the sex of a shark, look for the presence of claspers around the cloaca. Male sharks have claspers, females do not (*see Figure 14*). For spiny dogfish, measure the fork length from tip of the snout to the fork in the tail (*see Figure 15*).

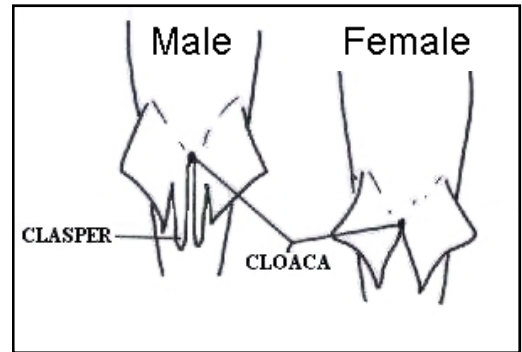

**Figure 14 Ventral surface of sharks**

For spiny dogfish spine collection, cut the entire second dorsal spine off, making sure to include the base of the spine.

Cut down at an angle just in front of and behind the spine, making a wedge (*see Figure 15*). Leave the flesh attached, place the spine in a barcode-labeled bag, and freeze. Record the data on your deck sheet and enter the data into ATLAS as specimen code 6 (spine). Store the dogfish specimens together in a clearly labeled bag in the freezer, to ensure that they are all turned in post-deployment.

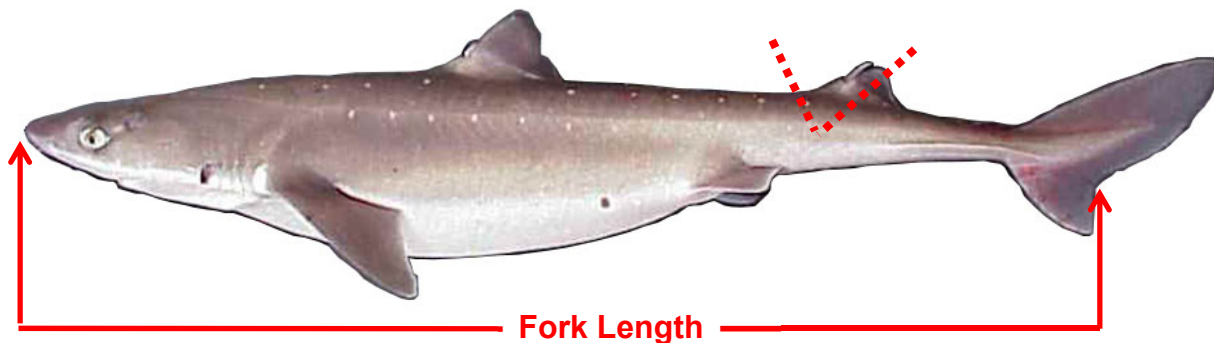

**Figure 15 Spiny dogfish fork length and age structure collection**

The “basket dump” method works for many species, however it does *not* work well for spiny dogfish, which have sandpaper-like skin and tend to clump and stick together. Use other methods to select your biospecimen fish randomly, such as choosing a random start point within your sample and setting aside the next 10 dogfish.

**Example:** Haul #27 has a fair amount of spiny dogfish, so Douglas decides to collect the first 10 dogfish after his hake average weight sample for his dogfish biospecimen sample.

## **Fish Collection**

The observer program can always use frozen fish specimens of just about anything of reasonable size. Please wrap fish individually and label clearly. If you see a rare or uncommon fish, or a fish that is out of its listed geographic range, please bring it back. We always appreciate high quality fish and invertebrate pictures, especially of rare species.



---

Keep a freezer inventory to ensure all of your frozen specimens are turned in post-deployment.

---

## **Entering Specimen Data in ATLAS**

The ATLAS Specimen Form has additional fields for specimen data in the hake fishery, triggered by the “HAK” haul purpose code. *For all specimens, enter the unique specimen number you assign and the weight*, which will automatically check specimen type 3.

### **Salmon biospecimens:**

Chinook and coho CWT and genetics data are entered into ATLAS specimen data (*see Figure 16*).

- **For Chinook and coho:**

- Check the specimen type “Otoliths (1)” checkbox, and then record the genetics barcode in the “Otolith Barcode” field.
- Check the specimen type “Fin Clips (4)” checkbox.
- Check the specimen type “Adipose (13)” checkbox, and then record whether the adipose fin was present by selecting Y, N, or U from the “Adipose Present?” dropdown.
- If you collected the snout from a CWT-tagged specimen, check the specimen type “Snout (12)” checkbox, then record the snout barcode in the “Snout Bar code” field.

Specimen Data	
Specimen Number	1
Weight	2.40 kg
Otoliths (1) <input checked="" type="checkbox"/>	Otolith Barcode: 100321654
Scales (2) <input type="checkbox"/>	
Sex-Length-Weight (3) <input checked="" type="checkbox"/>	
Fin Clips (4) <input checked="" type="checkbox"/>	
Vertebrae (5) <input type="checkbox"/>	
Spines (6) <input type="checkbox"/>	
Maturity Scan (7) <input type="checkbox"/>	Maturity Scan: [dropdown]
Maturity (8) <input type="checkbox"/>	Maturity Weight: [input]
Stomach (9) <input type="checkbox"/>	
Isotopes (10) <input type="checkbox"/>	
Other Tissue (11) <input type="checkbox"/>	
Snout (12) <input checked="" type="checkbox"/>	Snout Barcode: 12345678
Adipose (13) <input checked="" type="checkbox"/>	Adipose Present?: No [dropdown]

Specimen Data	
Specimen Number	12
Weight	2.40 kg
Otoliths (1) <input checked="" type="checkbox"/>	Otolith Barcode: 100456123
Scales (2) <input type="checkbox"/>	
Sex-Length-Weight (3) <input checked="" type="checkbox"/>	
Fin Clips (4) <input checked="" type="checkbox"/>	
Vertebrae (5) <input type="checkbox"/>	
Spines (6) <input type="checkbox"/>	
Maturity Scan (7) <input type="checkbox"/>	Maturity Scan: [dropdown]
Maturity (8) <input type="checkbox"/>	Maturity Weight: [input]
Stomach (9) <input type="checkbox"/>	
Isotopes (10) <input type="checkbox"/>	
Other Tissue (11) <input type="checkbox"/>	
Snout (12) <input type="checkbox"/>	Snout Barcode: [input]
Adipose (13) <input checked="" type="checkbox"/>	Adipose Present?: Yes [dropdown]

Figure 16 ATLAS entry for Chinook and coho genetics for CWT-tagged (top) and non CWT-tagged specimens (bottom)

**Genetics:**

Specimen Data	
Specimen Number	127
Weight	2.40 kg
Otoliths (1) <input checked="" type="checkbox"/>	Otolith Barcode: 100789258
Scales (2) <input type="checkbox"/>	
Sex-Length-Weight (3) <input checked="" type="checkbox"/>	
Fin Clips (4) <input checked="" type="checkbox"/>	
Vertebrae (5) <input type="checkbox"/>	
Spines (6) <input type="checkbox"/>	

Figure 17 ATLAS entry for genetics specimen

For non-salmon genetic specimens, check the specimen type “Otoliths (1)” checkbox, record the otolith barcode in the “Otolith barcode” field, and check the specimen type “Fin Clips (4)” checkbox (Figure 17).



## Spiny dogfish age structures:

Specimen Data	
Specimen Number	1274
Weight	0.87 kg
Otoliths (1)	<input checked="" type="checkbox"/>
Scales (2)	<input type="checkbox"/>
Sex-Length-Weight (3)	<input checked="" type="checkbox"/>
Fin Clips (4)	<input type="checkbox"/>
Vertebrae (5)	<input type="checkbox"/>
Spines (6)	<input checked="" type="checkbox"/>
Otolith Barcode	100321591

For spiny dogfish age structure specimens, check the specimen type “Otoliths (1)”checkbox, record the age structure barcode in the “Otolith barcode” field, and check the specimen type “Spines (6)”checkbox (*Figure 18*).

**Figure 18** ATLAS entry for spiny dogfish age structure specimen

For whole fish collection and special projects, only enter them in species comp data, as usual. There is no ATLAS specimen data needed for these A-SHOP collections.

## Data Quality Control

Although all data is recorded under the lead observer’s cruise number, both observers are equally responsible for accurate data collection and entry. Check each other’s deck sheet calculations and entry into ATLAS on a daily basis. Develop a data-entry/data-check system to ensure all data is entered and checked for accuracy (e.g., checkmarks, date/time). Use the red pencil issued with your hake gear to help you track which data has been double-checked and entered into ATLAS. Each pair of observers is a team and will most likely debrief together. Please work together to collect the best data possible.

## Communication

Bring any questions, concerns, and suggestions to program staff at any time. All hake vessels will have an in-season advisor. In addition to the manual, your in-season advisor is a great resource for answering sampling questions and responding to any problems that may arise. They will also let you know about any data errors found which can be fixed at sea, thereby speeding up your debriefing process. We encourage you to communicate directly with A-SHOP staff or with Jon McVeigh, Program Manager for the Fisheries Observation Science team (see Appendix C for contact information). Following your debriefing, please fill out the anonymous exit survey, which provides us with valuable feedback about the program.

## Mid-Cruise

Every observer will have a mid-cruise conducted via ATLAS message or by phone. After your first few days on board, you will be sent a list of questions asking about sampling methods to ensure that the protocols are clear and easy to follow. Answer the mid-cruise questions completely and promptly. If you or the observer program feels the interview should be done verbally, a time will be arranged so that it can be conducted over the phone.

## Debriefing and Specimen Turn-in

Notify your contractor and in-season advisor of your estimated arrival time in port. Your in-season advisor will inform you of current NOAA campus access protocols. You will need to debrief from your hake cruise as soon as you return, and before deploying to Alaska.

Turn in all of your data and specimens prior to debriefing.  
Deliver salmon snouts, dogfish samples, and clearly labeled specimens to the hake section of the Building 4 wet lab freezer.

While your contractor will schedule a debriefing check-in appointment for you, it will help streamline your check-in process to directly inform your in-season advisor of your appointment. If an observer is *unable to arrive on time* for their scheduled appointment, the debriefer needs to be notified.

Vessel surveys may be completed before you arrive at Sandpoint or at your appointed check-in time. The vessel survey link is: <https://apps-afsc.fisheries.noaa.gov/ords/f?p=189:LOGIN:438487914698>



Choose “HAKE” from the Fishery dropdown.

**Trawl Catcher Processor/Mothership - Hake**

Exit	Print
------	-------

Survey ID Number: 12863  
Fishery: **HAKE** ▼  
Survey Type: Trawl Catcher Processor/Mothership - Hake ▼

### **Gear Check-Out and Care**

Every observer pair will check out a set of gear that is specific to the sampling requirements for the hake fishery. The “A-SHOP Gear Sheet” in the front of the logbook lists the gear provided by the A-SHOP program. Store any extra gear (otolith vials, deck forms, Chinook genetics envelopes, etc.) and the CWT-detecting wand in a safe, dry area near the observer sampling station.

### **Gear Check-in Protocol**

After you check-in with A-SHOP staff, you will turn in your PLB and use the observer check-in computers at the NPOP computer room to make a gear check-in appointment and begin pre-debriefing tasks.

**Photo Credits:** Lauren Ackein, John Bieraugel, Cassandra Dahl, Cassandra Donovan, Lauren Hartman, Roy Morse, Lindsey Nelson, Greg Norris, Elizabeth Perkins, Merri Strayer, Jarrod Ver Steeg, Mark Wormington, Jennifer Wright – thank you observers!

The A-SHOP really appreciates you sharing copies of photos taken during your deployment. We use observer photos in training materials, fish lectures, and scientific presentations. If you do not wish for your photos to be used for these purposes, please let us know when you give them to us.

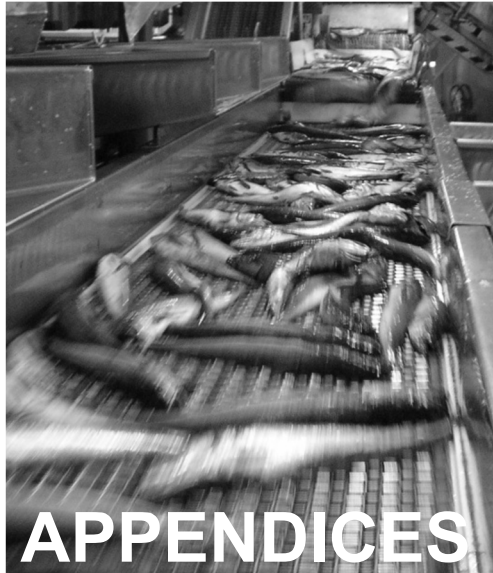

## Appendices Table of Contents

A-SHOP Observer Eligibility and Training Requirements.....	App. A
Pre-Cruise Vessel Bycatch Meeting Outline .....	App. B
Observer Program Contact Information.....	App. C
Catcher Vessel ADFG Numbers.....	App. D
Typical Low Bycatch Decksheet Example .....	App. E1
Flow Scale Subsampling Decksheet Example.....	App. E2
Basket Subsampling Decksheet Example.....	App. E3
High Bycatch Systematic Sampling Decksheet Example .....	App. E4
Frequently Asked Questions.....	App. F
Flow Scale Documents .....	App. G
Contractor Information .....	App. H
Whale Entanglement Hotline.....	App. I
Bed Bug Detection and Mitigation for Observers .....	App. J
Conflict Resolution Recipe.....	App. K

## Appendix A. A-SHOP Observer Eligibility and Training Requirements

Observer Programs have broad latitude to maintain continuity of operations while coping with the challenges brought on by the COVID-19 pandemic. This means some eligibility and training requirements may change or be revised.

### Eligibility requirements:

- Observer is a currently certified North Pacific Observer Program (NPOP) observer.
- Observer has completed one or more satisfactory deployments with the NPOP.
  - Deployment scores: 1 = satisfactory; 0 = unsatisfactory
- Observer has received satisfactory deployment scores for every vessel/plant from their most recent deployment.
- If an observer receives an unsatisfactory deployment score on an A-SHOP deployment, the observer must complete an A-SHOP 4-day training prior to deploying again in the hake fishery.

### Training requirements:

- Observer must complete the safety training and meet any requirements for participating in drills and donning equipment, including donning an immersion suit in less than 60 seconds.
- Observer must pass the fish exam with an 80% or better.
- Observer must pass the written quiz with an 80% or better. This quiz is closed book.
- Observer must attend the full, 4-day A-SHOP training.
  - Arrive on time, at the beginning of each day and returning from breaks. Tardiness may result in being dropped from the class.
- Observer must successfully complete any homework or in-class exercises and make any corrections requested by the trainers.
- Use of electronic devices during fish lab and exam is prohibited.

Additionally, new trainees must be able to demonstrate to the trainer that they have the attitude and ability required to perform a difficult job independently, and to act professionally in stressful situations.

Observers who do not pass both the fish exam and the written quiz must take the full A-SHOP training again. In the spring, when back-to-back trainings are offered, observers in the first training may not repeat the training immediately afterwards, due to class size limits.

Training class size is limited to 25 observers unless the Program allows more, as deemed necessary.

## Appendix B. Pre-Cruise Bycatch Discussion Outline

### NOAA Fisheries At-Sea Hake Observer Program

**Purpose of discussion:** To stress cooperation and communication between observer and vessel personnel in order to maximize sample sizes for hauls with species of concern.

**Who should attend:** Observers, captain, factory manager/foreperson, backline operator

#### Outline:

##### 1. Introductions

- a. Who is in attendance? Who is not at the meeting that needs to be in the loop (i.e. backline operator, mate)?
- b. What is the preferred order of communication on the vessel? (e.g. foreperson → factory manager → captain)

##### 2. Review bycatch limit - Discuss the species of concern in 2022

**Suggested thresholds of action** - Hauls with >25 Chinook (individual fish)

##### 3. Sampling goals - Remind crew that the observer will collect 50% samples whenever possible. Use the flow chart below to go over the sampling options for tows with species of concern. Discuss the actions that can be taken to maximize sample size when the haul is dirty or when species of concern are an issue:

- A. Notifying observers of dirty hauls (making observer aware of bycatch if they were not present at the codend dump)
- B. Vessel providing help (assistance with sorting, lifting, dumping)
- C. Adjusting belt speed
- D. Collecting multiple small samples (with cooperation from bleeder and sorters)

## A-SHOP Sampling Protocol Review

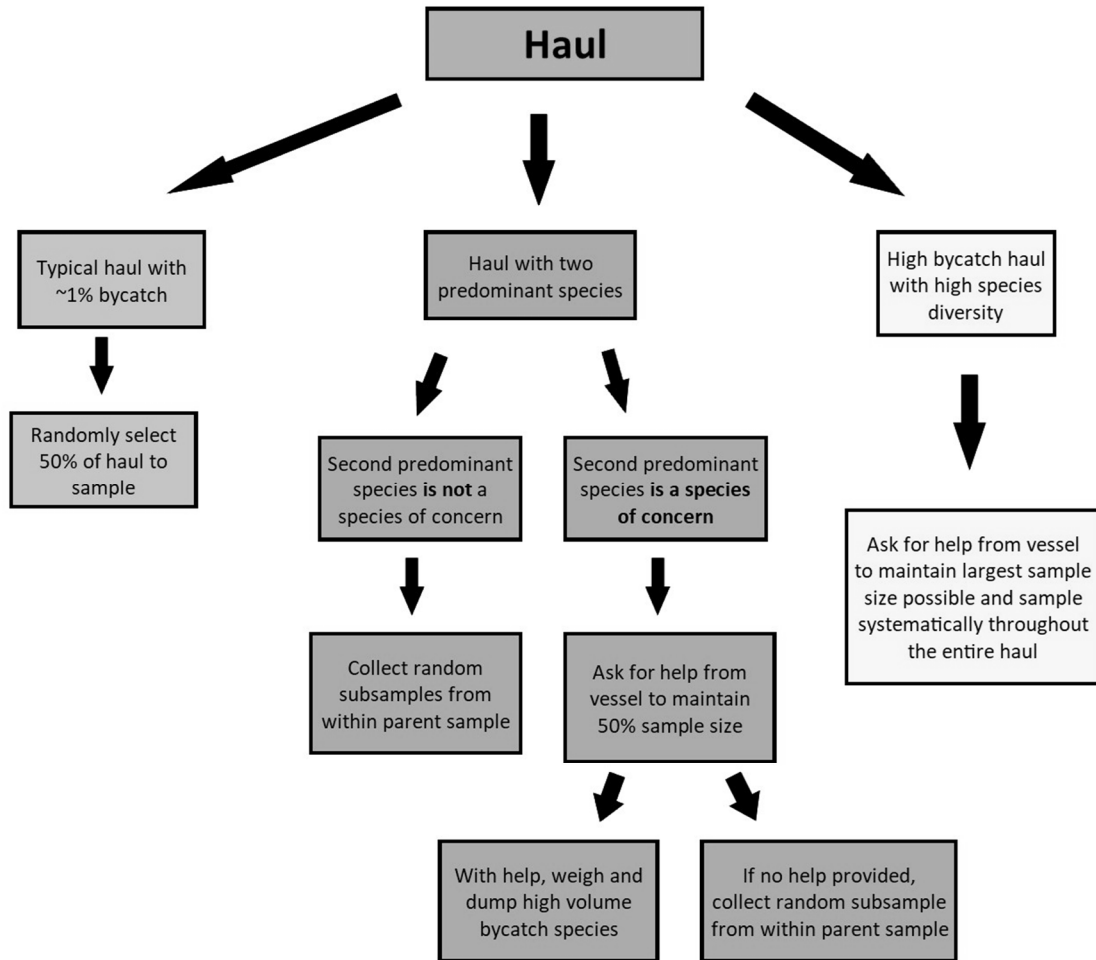

Species of concern may vary over time, but high levels of Chinook bycatch are always reason for maintaining a large sample size whenever possible.



## **Appendix C. Observer Program Contact Information**

### **A-SHOP contacts**

*Office location:* Sand Point, Building 4, Room 1156

Cassandra Donovan                      Phone: 206-526-6724  
E-mail: Cassandra.Donovan@noaa.gov

Jeannine Memoly                      Phone: 206-526-6782  
Email: Jeannine.Memoly@noaa.gov

Vanessa Tuttle                      Phone: 206-860-3479  
E-mail: Vanessa.Tuttle@noaa.gov

Jon McVeigh                      Phone: 206-302-2423  
E-mail: Jon.McVeigh@noaa.gov

**Note:** Please leave a message, including a phone number, if we do not answer. We are likely just away from our desks for a moment and will call you right back. Listen to what the voice mail message says. When one of us is out at sea, the message will say so, and you should contact the next person on this list.

### **ATLAS questions or problems**

Glenn Campbell (AFSC):              Phone: 206-526-4240  
Email: Glenn.Campbell@noaa.gov

### **Enforcement**

For emergencies:                      Hot line: 1-800-853-1964

Non-emergency:

Enforcement Officer Sonya Jordan      Phone: 206.348.9100  
Email: sonya.jordan@noaa.gov

### **Sexual Assault / Sexual Harassment Helpline**

Phone: (866) 288-6558; Text: (202) 335-0265

Website & Online Chat: NOAASASHhelpline.org

Reporting Email: noaa.victimservices@noaa.gov

General Email: violence.prevention@noaa.gov

### **NOAA Marine Mammal Disentanglement Hotline:**

1-877-SOS-WHAL(e) (1-877-767-9425).

## Appendix D. Catcher Vessel ADFG numbers

Catcher Vessel	ADFG #
Alyeska	45
Arctic Fury	68869
Bay Islander	49618
Blue Fox	62892
Caitlin Ann	59779
California Horizon	33697
Collier Brothers	54648
Crysan	575942
Leslie Lee	56119
Lisa-Melinda	41520
Marathon	49617
Mar-Gun	12110
Mark I	6440
Messiah	66196
Miss Berdie	59123
Miss Sarah	64109
Miss Sue	580055
Misty Dawn	68858
Muir Milach	41021
Neahkahnne	32858
New Life	21845
Nordic Fury	200
Nordic Star	961

Catcher Vessel	ADFG #
Pacific Challenger	6931
Pacific Fury	33
Pacific Prince	61450
Pacific Ram	61792
Papado II	55512
Pegasus	57149
Perseverance	12668
Predator	33744
Raven	56395
Sea Clipper	62
Sea Storm	40969
Sea Dawn	77
Seeker	59476
Starward	39197
Traveler	58821
Western Dawn	22294
Winona J	43383



## Appendix E2. Flow scale Subsampling Decksheet Example

### A-SHOP Deck Form

Date	Lead Cruise	Permit	Haul #	Sampled by	Page <u>49</u> of _____ for Vessel
5/27/16	13579	9876	42	13579	Page <u>1</u> of <u>5</u> for Haul

Sample #	Subsample #	Sample Size	Presorted?
1		29340 kgs	Y <input checked="" type="radio"/> N

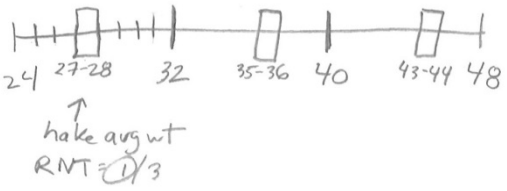
Species	#	Weight	% ret.	Sample design, sex-lengths, specimens, viabilities, mammals, birds, notes:
-----Key punch-----	70	84.62	X	~48 MT 1 (2) lots of yellowtail! ~1 MT subsamples FS end: 53387 FS start: 24047 RNT = (4)/8  POP F   M 42   (39) (45)   (47) 48 F 45-.84-510847 M 39-.52-510848 M 47-.98-510849
Hake	0	0	100	
Yellowtail	0	0	100	
squid unid	57	13.98	0	
squid unid	0	35.60	0	
squid unid	0	29.18	0	
Amshad	8	2.32	100	
POP	5	3.54	100	

Date	Lead Cruise	Permit	Haul #	Sampled by	Page <u>50</u> of _____ for Vessel
5/27/16	13579	9876	42	13579	Page <u>2</u> of <u>5</u> for Haul

Sample #	Subsample #	Sample Size	Presorted?
	101	1121 kgs	Y <input checked="" type="radio"/> N

Species	#	Weight	% ret.	Sample design, sex-lengths, specimens, viabilities, mammals, birds, notes:
-----Key punch-----	111	1121.00	X	hake F   M 32   29 34   33 36   35 F 37   36 F 40 M   38 42 FS end: 28114 FS start: 26993 sample wt 1121.00 -hake avg -24.12 -bycatch -83.10 hake wt = 1013.78
Hake	0	1013.78	100	
Hake	57	24.12	100	
Yellowtail	24	39.20	100	
Yellowtail	26	42.85	100	
Amshad	1	0.15	100	
squid unid	3	0.90	0	

## A-SHOP Deck Form

Date	Lead Cruise	Permit	Haul #	Sampled by
5/27/16	13579	9876	42	13579

Page 51 of \_\_\_\_\_ for Vessel

Page 3 of 5 for Haul

Sample #	Subsample #	Sample Size	Presorted?
	102	1078 kgs	Y <input checked="" type="radio"/> N

Species	#	Weight	% ret.	Sample design, sex, lengths, specimens, viabilities, mammals, birds, notes:
-----Keypunch-----	46	1078.00	X	sample wt 1078.00 -bycatch -76.30 <hr/> hake wt = 1001.70  FS end: 36097
Hake	0	1001.70	100	
Yellowtail	25	41.08	100	

## A-SHOP Deck Form

Date	Lead Cruise	Permit	Haul #	Sampled by
5/27/16	13579	9876	42	13579

Page 52 of \_\_\_\_\_ for Vessel

Page 4 of 5 for Haul

Sample #	Subsample #	Sample Size	Presorted?
	103	1076 kgs	Y <input checked="" type="radio"/> N

Species	#	Weight	% ret.	Sample design, sex, lengths, specimens, viabilities, mammals, birds, notes:
-----Keypunch-----	56	1076.00	X	sample wt 1076.00 -bycatch -89.54 <hr/> hake wt = 986.46  FS end: 44047 FS start: 42971  otol genetics RE F 51-2.92 510850
Hake	0	986.46	100	
Yellowtail	33	53.78	100	
Yellowtail	20	32.64	100	
Squid unid	2	0.20	0	
Parakeye	1	2.92	100	

Date	Lead Cruise	Permit	Haul #	Sampled by
5/27/16	13579	9876	42	13579

Page 53 of \_\_\_\_\_ for Vessel

Page 5 of 5 for Haul

Sample #	Subsample #	Sample Size	Presorted?
	104	944 kgs	Y <input checked="" type="radio"/> N

Species	#	Weight	% ret.	Sample design, sex, lengths, specimens, viabilities, mammals, birds, notes:
-----Keypunch-----	66	944.00	X	sample wt 944.00 -bycatch -88.83 <hr/> hake wt = 845.17  FS end: 52051 FS start: 51107
Hake	0	845.17	100	
Yellowtail	29	47.80	100	
Yellowtail	32	50.08	100	
Squid unid	5	0.95	0	

### Appendix E3. Basket Subsampling Decksheet Example

#### A-SHOP Deck Form

Date	Lead Cruise	Permit	Haul #	Sampled by
5/28/16	13580	9867	44	13580

Page 55 of \_\_\_\_\_ for Vessel  
 Page 1 of 5 for Haul

Sample #	Subsample #	Sample Size	Presorted?
1		29668 kgs	Y <input checked="" type="radio"/> N

Species	#	Weight	% ret.	Sample design, sex lengths, specimens, viabilities, mammals, birds, notes:																																
-----Keypunch-----	27	17.77	X	RNT 1/2 (1)2 ~ 60mt																																
Hake	0	0	100	Lots of dogfish!																																
Spiny dog	0	0	0	FS end: 29668 Will sample																																
Widow	3	1.98	0	FS start: 0 2-quad using																																
Yellowtail	6	9.64	0	29668 baskets.																																
Lampry mFH	1	0.02	0	Sample ~ 30mt,																																
Squid unid	17	6.13	0	3 subsamps 0-10 R# 1																																
				0-30 mt / baskets @ 0, 10, 20																																
				<table border="0"> <tr> <td colspan="2">Widow</td> <td colspan="2">Yellowtail</td> </tr> <tr> <td>M</td> <td>E</td> <td>M</td> <td>F</td> </tr> <tr> <td>(36)</td> <td>(37)</td> <td>41</td> <td>42</td> </tr> <tr> <td></td> <td>41</td> <td>43L</td> <td>(43)</td> </tr> <tr> <td></td> <td></td> <td></td> <td>(45)</td> </tr> <tr> <td colspan="2">otos</td> <td colspan="2">otos</td> </tr> <tr> <td colspan="2">731511 m 36, 0.70</td> <td colspan="2">731513 F 43, 1.18</td> </tr> <tr> <td colspan="2">731512 F 37, 0.76</td> <td colspan="2">731514 F 45, 1.26</td> </tr> </table>	Widow		Yellowtail		M	E	M	F	(36)	(37)	41	42		41	43L	(43)				(45)	otos		otos		731511 m 36, 0.70		731513 F 43, 1.18		731512 F 37, 0.76		731514 F 45, 1.26	
Widow		Yellowtail																																		
M	E	M	F																																	
(36)	(37)	41	42																																	
	41	43L	(43)																																	
			(45)																																	
otos		otos																																		
731511 m 36, 0.70		731513 F 43, 1.18																																		
731512 F 37, 0.76		731514 F 45, 1.26																																		



## A-SHOP Deck Form

Date	Lead Cruise	Permit	Haul #	Sampled by
5/28/16	13580	9876	44	13580

Page 58 of \_\_\_\_\_ for Vessel

Page 4 of 5 for Haul

Sample #	Subsample #	Sample Size	Presorted?
	103	108.60 kgs	Y <input checked="" type="radio"/> N

Species	#	Weight	% ret.	Sample design, sex-lengths, specimens, viabilities, mammals, birds, notes:
-----Keypunch-----	45	108.60	X	3 bkts @ 20  FS end: FS start:
Hake	0	32.16	100	
↓	0	28.72	100	
Hake	0	30.42	100	
Spiny dog	44	17.28	0	
Lamprey in ID	1	0.02	0	

## A-SHOP Deck Form

Date	Lead Cruise	Permit	Haul #	Sampled by
5/28/16	13580	9876	44	13580

Page 59 of \_\_\_\_\_ for Vessel

Page 5 of 5 for Haul

Sample #	Subsample #	Sample Size	Presorted?
2		62277.85 kgs	<input checked="" type="radio"/> Y <input type="radio"/> N

Species	#	Weight	% ret.	Sample design, sex-lengths, specimens, viabilities, mammals, birds, notes:
-----Keypunch-----	1	129.85	X	+ 129.85 <sup>Shark</sup> FS end: 62148 FS start: <u>62277.85</u>  Shark total l = 215cm Fork l = 201cm
Salmon shark	1	129.85	0	
				(cut shark into 3 pieces) <hr/> # 1 45.96 # 2 42.18 # 3 41.71 <hr/> 129.85 kg



# Appendix E4. High Bycatch Systematic Sampling Decksheet Example

## A-SHOP Deck Form

Date	Lead Cruise	Permit	Haul #	Sampled by	Page <u>21</u> of <u>      </u> for Vessel
5/19/22	74242	4123	17	74242	Page <u>1</u> of <u>6</u> for Haul

Sample #	Subsample #	Sample Size	Presorted?
1		1004 kgs	Y (N)

@ 2 MT

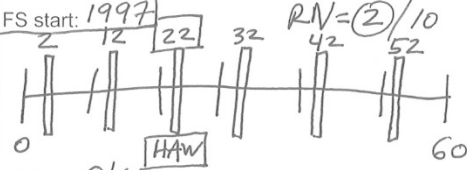
Species	#	Weight	% ret.	Sample design, sex-lengths, specimens, viabilities, mammals, birds, notes:
-----Keypunch-----	236	1004.00	x	60 MT Lots of mackerel & shortbelly! systematic FS samples 1 on / 9 off FS end: 3001 FS start: 1997 
Hake	Ø	887.44	100	
Jack mack	75	42.96	Ø	
Jack mack	66	35.82	Ø	
Pac mack	34	24.66	Ø	
Shortbelly	51	9.14	Ø	
Am shad	5	2.86	Ø	
Squid	5	1.12	Ø	
				Sample size 1004.00 - bycatch 116.56 ----- hake 887.44

Sample #	Subsample #	Sample Size	Presorted?
2		1003 kgs	Y (N)

@ 12 MT

Species	#	Weight	% ret.	Sample design, sex-lengths, specimens, viabilities, mammals, birds, notes:
-----Keypunch-----	204	1003.00	x	FS end: 13011 FS start: 12008 sample 1003.00 -bycatch 99.00 ----- hake 904
Hake	Ø	904.00	100	
Jack mack	61	38.16	Ø	
Jack mack	53	29.74	Ø	
Pac mack	24	17.62	Ø	
Shortbelly	62	11.18	Ø	
Jelly	4	2.30	Ø	

Sample #	Subsample #	Sample Size	Presorted?
3		1012 kgs	Y (N)

@ 22 MT

Species	#	Weight	% ret.	Sample design, sex-lengths, specimens, viabilities, mammals, birds, notes:
-----Keypunch-----	214	1012.00	x	FS end: 23014 FS start: 22002 sample 1012.00 -bycatch 71.26 -HAW 32.14 ----- hake 908.60
Hake	Ø	908.60	100	
Hake	53	32.14	100	
Jack mack	74	40.76	Ø	
Pac mack	24	18.88	Ø	
Shortbelly	52	8.90	Ø	
Squid	11	2.72	Ø	

hake	
F   M	
39   38	
41   39	
42   40	
44   41	

## Appendix F. Frequently Asked Questions

- 1. I cannot log into ATLAS or I cannot transmit, what do I do?**  
Contact Glen Campbell. His contact information is in Appendix C.
- 2. Which estimate do I use as the vessel estimate on the OHF? The estimate given when the bag is hauled up or the one recorded in the logbook?**  
Use the vessel estimate recorded in the logbook.
- 3. For “Estimated Discard Weight” on the OHF, do I use the actual weighed discards from my sample or should I extrapolate it up to the haul level?**  
Extrapolate discards up to the haul level. See “Estimated Discard Weight Options” on page 26 for discard estimation options.
- 4. How do I calculate percent retained?**  
Percent retained is an estimate. Visually estimate how much of each species is being retained by the vessel. Ask vessel crew which belts are going over-board (discard) and which are going to fishmeal (retained) so that your percent retained estimates are as accurate as possible.
- 5. I am on a mothership and the captain is recording catcher vessel discards in the vessel logbook. How do I account for these discards in my data?**  
Use the protocols in the “Mothership Catcher Vessel Discard Accounting” on page 27 for how to track and record catcher vessel discards.
- 6. I am on a mothership and the captain has not received any discard info from one of the catcher vessels. What do I do?**  
Ask the mothership captain to obtain the catcher vessel’s discard amounts from the catcher vessel captain. Catcher vessel discard data will be reviewed and verified during debriefing.
- 7. What changes if the vessel is participating in the tribal fishery?**  
You will enter a tribal code in the CDQ/Tribal code column for each haul. Each tribe has its own code. Contact the A-SHOP for the appropriate code. The vessel you are on will receive catch from tribal catcher vessels, so “Vessel Type” is code 2 (mothership) and the ADFG numbers for the catcher vessels need to be recorded on the OHF. Tribal vessels may not carry observers or EM so there will not be CV discard data. All other sampling and data protocols remain the same.
- 8. What are the haulback notification guidelines for hake?**  
The vessel is required to notify you 15 minutes prior to haulback. Regardless of this requirement, it is your responsibility to know what is going on during your shift. Never assume the crew is going to inform you - it is not their job to search the boat for you. It is reasonable to say that you will be either in the factory, the galley or the wheelhouse. If reasonable notification efforts are not made, discuss the situation with the captain,

document it in your logbook, and inform your in-season advisor.

**9. Whose cruise number goes on the deck forms and genetic envelopes?**

The lead observer's cruise number goes on both, regardless of who collected the data.

**10. I subsampled for two predominant species and randomly collected my hake average weight sample from outside a subsample. How do I enter it in ATLAS?**

You cannot enter a count and weight for a species in a sample that is also recorded as 0 count/0 weight in the same sample. Record your hake average weight sample as a separate small subsample (e.g. subsample #104 – hake: 57 count / 29.54kg weight).

**11. I have 10 spiny dogfish sharks and 1 spiny dogfish shark headless body in my species comp sample. I took sex/lengths from all 10 whole fish - do I use sample design code 10 (census) or another code?**

Include the weight of the shark part in with the weight of the 10 whole sharks and record the lengths as census - code 10.

**12. For sex/lengths, when do I use sample design code 10?**

Sample design codes are recorded at both the haul level, for species comp samples, and at the sex/length sample level - they are independent of each other. For example, if you sampled half of a haul by randomly choosing the first or second half, your haul sample design code would be 6 - simple random. If you took sex/lengths from all the rougheyeye rockfish in your species comp sample, your length sample design would be 10 - census.

**13. What do we do if it is time to change shift and the observer whose shift is ending is in the middle of a sample?**

The usual protocol for shift-crossing samples is for the observer coming on shift to come to the factory, check-in with the observer currently sampling about haul specifics (size, diversity, average weight sample coming up, etc.) or check the decksheet where all this is written and then say something along the lines of 'OK, I got it from here, have a good off shift, don't eat too much ice cream,' and then take over sampling the haul.

# Appendix G. Flow Scale Documents

## Daily Flow Scale printout example – get copies to turn in for debriefing

Marel M2200 X02 Haul Report

=== HAULS ===

Date and Time.....: 2016-11-20 14:00:38

Device name.....:

Vessel.....: Boaty McBoatFace

Vessel Permit #...:

Accumulated Total.: 46927218 kg

CAL/CON/MARCAL....: 15/13/461

Total Hauls/Tests.: 46840621 kg / 86598 kg

Haul #	Date	Time	Weight	Totalizer	ReLoads
-> 1281	2016-11-18	23:43:02	14438.2 kg	46912780.0 kg	0
1282	2016-11-18	19:03:38	0.0 kg	46912364.0 kg	0
1280	2016-11-18	11:47:30	12962.0 kg	46899403.0 kg	0
1279	2016-11-18	02:50:55	29790.0 kg	46869613.0 kg	0
1278	2016-11-17	22:25:28	17146.0 kg	46852468.0 kg	0
1277	2016-11-17	17:25:08	42671.0 kg	46809796.0 kg	0
1276	2016-11-17	10:28:07	59858.0 kg	46749525.0 kg	0

Revised 4/10/13

CMB Control No. 0648-0330  
Expiration Date: 11/30/2015

### RECORD OF DAILY SCALE TESTS



Vessel Name: \_\_\_\_\_ Date: \_\_\_\_\_

Time test started: \_\_\_\_\_

#### I. TEST PLATFORM SCALE

10kg (9.95-10.05kg)      25kg (24.88-25.13kg)      50kg (49.75-50.25kg)

#### II. WEIGH FISH ON OBSERVER PLATFORM SCALE

BASKET #	WT FISH + BASKET (kg)	BASKET #	WT FISH + BASKET (kg)	BASKET #	WT FISH + BASKET (kg)	BASKET #	WT FISH + BASKET (kg)
1		8		15		21	
2		9		16		22	
3		10		17		23	
4		11		18		24	
5		12		19		25	
6		13		20		26	
7		14		Total weight all fish+baskets		0.00	

#### III. CALCULATE PERCENT ERROR OF FLOW SCALE

Scale Indicator

Begin Test: \_\_\_\_\_ kg

End Test: \_\_\_\_\_ kg

TOTAL WEIGHT FISH AND BASKETS (kg)	-	WEIGHT OF BASKET	=	PLATFORM SCALE WEIGHT OF FISH (kg)	WEIGHT OF FISH ON FLOW SCALE (kg)	ERROR (B) - (A)	% ERROR = (C) + (A) X 100
				(A)	(B)	(C)	

#### IV. SEA CONDITIONS (BEAUFORT SCALE) AT TIME OF SCALE TEST (CHECK ONE):

0  1  2  3  4  5  6  7  8  9  10  11  12

SIGNATURE OF VESSEL OPERATOR

I observed this test and to the best of my knowledge it was conducted in accordance with 50 CFR 679.28 (b)(3)

Signature of observer

## **Appendix H. Contractor Information**

### **Alaskan Observers, Inc. (AOI)**

130 Nickerson, Suite 206

Seattle, WA 98109

Phone: (206) 283-7310

Fax: (206) 283-6519

E-mail: [aoistaff@alaskanobservers.com](mailto:aoistaff@alaskanobservers.com)

[www.alaskanobservers.com](http://www.alaskanobservers.com)

### **Saltwater, Inc. (SWI)**

733 N. Street

Anchorage, AK 99501

Phone: (907) 276-3241

Fax: (907) 258-5999

E-mail: [stacey.hansen@saltwaterinc.com](mailto:stacey.hansen@saltwaterinc.com)

E-mail: [joann.alvarez@saltwaterinc.com](mailto:joann.alvarez@saltwaterinc.com)

[www.saltwaterinc.com](http://www.saltwaterinc.com)

# Appendix I How to Report an Entangled Whale

The public plays an important role in saving distressed whales, like those that become entangled. Prompt reporting and monitoring of the animal are the best ways to help.

**You can report large whales in distress to either:**

**The 24/7 reporting hotline:  
1-877-SOS-WHAlE (767-9425)**

*or*

**The United States Coast  
Guard on VHF CH-16**

Entangled whales are unpredictable and potentially dangerous. Please keep a safe distance and do not approach the animal. You can continue to monitor the animal's condition and document the encounter while waiting for a response team to arrive.

## What to include in your Report

1. Location of the animal;
2. A detailed description of the color and gauge of rope;
3. Location of gear on the whale;
4. Color and size of buoys;
5. Direction of the whale's movement, including whether it is solitary or with a group;
6. Behavior of the whale, including whether it is surfacing or diving, and the length of dive times;
7. Species of whale; and
8. Size and condition of the whale.

**Documentation in the form of photos and videos of the entangled whale can provide valuable information to the responders and resource managers. The information from each whale entanglement contributes to our larger knowledge-base and can be a valuable tool in helping to prevent future entanglements.**



Gray Whale (*Eschrichtius robustus*) 39-46 feet



Humpback whale (*Megaptera Novaeangliae*) 40-60 feet

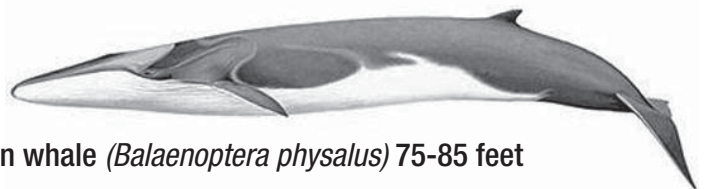

Fin whale (*Balaenoptera physalus*) 75-85 feet

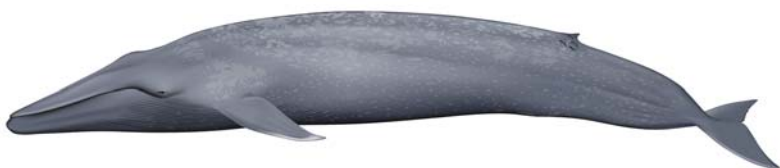

Blue whale (*Balaenoptera musculus*) 88-108 feet



**NOAA  
FISHERIES**

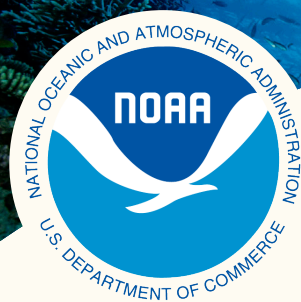

## NOAA FISHERIES

### National Observer Program Advisory Team's Safety Advisory Committee

The Safety Advisory Committee (SAC) advises the National Observer Program Advisory Team (NOPAT) on matters of observer safety, health, and welfare. It works to promote a safer and healthier environment for observers to work in and is responsible for developing and recommending the requirements necessary to fulfill NOPAT's national safety standards, including:

- Spearheading and reviewing proposals on observer safety initiatives, along with monitoring and advising on any safety policies and programs which may affect NOAA Fisheries observers.
- Addressing specific safety issues through seminars, workshops, forums, and panel discussions.
- Developing training classes and standards for observer programs' safety trainers.
- Creating and maintaining enforcement mechanisms to enforce safety-related policies for observer programs.

#### FOR MORE INFORMATION

Dennis Hansford

[dennis.hansford@noaa.gov](mailto:dennis.hansford@noaa.gov)

(301) 427-8136

[fisheries.noaa.gov/topic/fishery-observers](https://fisheries.noaa.gov/topic/fishery-observers)

## Bed Bug Detection and Mitigation for Observers

### Safety First For Successful Monitoring

We depend on our observers and at-sea monitors—professionally trained scientists who gather crucial information about what species are caught and thrown back by U.S. commercial fishing vessels—to be our eyes and ears on the water. The work of observers is critical to effective fisheries management, and their safety on the job is of utmost importance. Although the marine environment can be challenging, ensuring that observers have comfortable and healthy working conditions is a top priority.

### The Challenge: Bed Bugs

Bed bug (*Cimex lectularius*) populations have been increasing and spreading across the globe since the 1990s, and vessels at sea are not immune to this phenomenon. Characterized by feeding on human blood, usually at night, bed bugs typically cause a rash which can lead to itchiness, fever, fatigue, and mental distress.



### The Solution: Vigilance

Once bed bugs are onboard a ship, they can be extremely difficult to exterminate. However, there are steps observers can take to detect and reduce the presence of bed bugs.



#### Where should I check?

You should check the bunk area, particularly the bedding and sleeping area for signs of bed bug infestation. Mattress seams and crevices near your bunk are places where bed bugs often hide.



#### What should I look for?

- Bed bug eggs look like tiny grains of rice.
- Bed bugs leave dark, grainy droppings that appear as dark spotting on bedding.
- Bed bugs can also leave cast-off husks from molt.

#### What should I do if I find signs of bed bugs in my assigned sleeping area?

If detected, you should document it and provide notice during your debriefing.

#### What do I tell the captain or vessel master?

If you find signs of bed bugs in your cabin and sleeping area, tell the captain what you found and share the tips below to reduce or eliminate the infestation.

#### What can I do to mitigate bed bugs in my sleeping area?

Getting rid of bed bugs is a constant effort, but there are several things you can do to reduce the presence of bed bugs:

- Vacuum the area, especially the crevices and seams.
- Place the mattress in a removable mattress cover.
- Treat the area with steam and/or insecticide if possible.
- Shake out infested bedding, and wash if possible.

#### What can I do to reduce bed bugs in my gear?

Just as with bedding, gear can also play host to bed bugs. To reduce the spread of bed bugs among gear, try to keep your gear stowed separately from others, in a plastic bin if possible. Controlling clutter is another step that will minimize potential habitats for bed bugs.

#### How do I make sure I don't bring bed bugs ashore?

Don't assume you need to throw out all your gear and bedding when you return home. Instead, continue to keep your gear separate from other belongings at your home before washing and heat-drying your laundry (and laundry bags). Continue to vacuum other items as needed, changing bags/filters in the vacuum as necessary and discarding them in tightly sealed plastic bags placed in outside trash bins.

## Appendix K. Conflict Resolution Recipe

*excerpted from Fieldwork Toolkit Series - Trip Planning: Risk Management for Field Settings*

### A Recipe for Resolving Conflict

1. Plan all this out first!
2. Connection before Correction
3. Identify what you're noticing & set up a time to meet
4. State your goals at the meeting
5. Take time to listen, listen, listen
6. Invite and give feedback
7. Take one of several actions
8. Make a plan to check in again
9. Reassure them, appreciate them, and thank them for talking.

### Possible actions:

- Make a request
- Clarify expectations and suggest ways they can meet them
- Collaboratively problem-solve
- Help them understand the ramifications of their actions
- Agree to meet again and continue discussing



## Index

- Adipose fin..... 31
- Alaskan Observers, Inc. (AOI) .....See  
Contractor information
- Albatross ..... 13
- ATLAS..... 9, 13, 38, 41, 48
- ATLAS specimen data..... 39
- At-sea transfers ..... 4
- Average weight samples ..... 25
- Biospecimen Sampling ..... 35
- Biospecimen Sampling Protocols ..... 35
- Bird Interaction, Activity and Species Form  
..... 13
- Bycatch ..... 7, 8, 9, 19, 25, 29, 38
- Bycatch limits ..... 7
- Canary rockfish..... 7
- Catcher Vessel ADFG Numbers..... 12,  
Appendix D
- Catcher vessels..... 6
- Chinook genetics..... 32
- Coded wire tags. See CWT - coded wire tags
- Communication..... 41
- Confidentiality ..... 5
- Conflict Resolution ..... Appendix K
- Contact information ..... Appendix C
- Contractor information..... Appendix I
- CWT - coded wire tags ..... 31
- Data quality control..... 41
- Debriefing ..... 42
- Discard Estimates..... 25
- Discards, Mothership Catcher Vessels ..... 26
- Dumping, codend..... 14
- EM – electronic monitoring ..... 26
- Enforcement..... See Contact information
- Estimated Discard Weight ..... 25
- Fish specimens ..... 39
- Flow scale ..... 14, 15, 16, 17
- Flow scale test..... 15
- Frequently Asked Questions ..... Appendix G
- Gear..... 42, 43
- Genetics..... 35, 37
- High Bycatch Sampling ..... 23
- High Bycatch Systematic Sampling  
Decksheet Example..... Appendix E
- Hoh.....See Tribal fishery
- In-season advisor ..... 16, 18, 35, 41
- Length to weight tables..... 17
- Lengths..... 12, 35, 37, 38
- Makah .....See Tribal fishery
- Marine Mammal Interaction and Specimen  
Form..... 13
- Marine mammals ..... 11, 13, 14
- MARPOL..... 9
- Mid-cruise..... 41
- Mothership Catcher Vessel Discard  
Accounting..... 26
- Motion compensated platform scale (MCP)  
..... 15, 16
- non-fishing day ..... 12
- noon position..... See non-fishing day
- Observer Catch Estimates ..... 14, 16, 17
- Observer catch reporting..... 12
- Observer program contact information.....See  
Contact information
- Otoliths..... 35, 37
- Pectoral fin clip..... See Chinook genetics
- Percent Retained ..... 25
- photos..... 28
- Pre-cruise meetings..... 8
- Pre-Cruise Vessel Bycatch Meeting Outline  
Appendix B
- Presorted Organisms ..... 16, 17
- Priority list ..... 4, 9, 11, 13, 14, 25, 35, 37
- Prohibited species ..... 29
- Protected Species ..... 29
- Purpose code, VHF ..... 12
- Quileute..... See Tribal fishery
- Quinault..... See Tribal fishery
- Random sample table..... 18
- Record of Daily Flow Scale Tests Appendix  
H
- Regulations, fishing ..... 10
- Regulations, observer..... 5
- Regulations, vessel..... 9
- RNT, random number table ..... 17
- Rockfish ..... 8, 10, 35
- Rockfish, sexing..... 37
- Sablefish, sexing ..... 37
- Safety ..... 4

Salmon .....	29, 30	Species ID forms.....	28
Salmon Biospecimen Sampling.....	30	Species of concern .....	8
Salmon retention .....	29	Spiny Dogfish Protocols .....	38
Salmon Sampling Deck Form.....	31, 32, 34	Sturgeon .....	35
Salmon Subsampling .....	33	Subsampling Decksheet Example. Appendix E	
Saltwater, Inc. (SWI) .....	See Contractor information	Subsampling For Two Predominant Species .....	21
Sampling ....	1, 6, 8, 9, 11, 13, 14, 15, 16, 17, 18, 19, 20, 24, 25, 30, 31, 32, 33, 34, 41, 42	Subset Sampling.....	See Average weight samples
Sampling for large sharks .....	17	Time management.....	12
Sampling options flowchart.....	19	Tribal fishery.....	7
Sampling, Species Composition .....	18	Turtle, sea.....	14
Scale Testing.....	14	vessel logbooks .....	9
sea turtles .....	13	Vessel safety checklist .....	4
Seabirds.....	13	Wand, CWT sampling .....	31, 42
Signing Documents.....	10	whale entanglement .....	13