

Marine Studies of San Pedro, California

CIRCULATING COPY
Sea Grant Depository

PART 12

BIOENHANCEMENT STUDIES OF THE RECEIVING WATERS
IN OUTER LOS ANGELES HARBOR

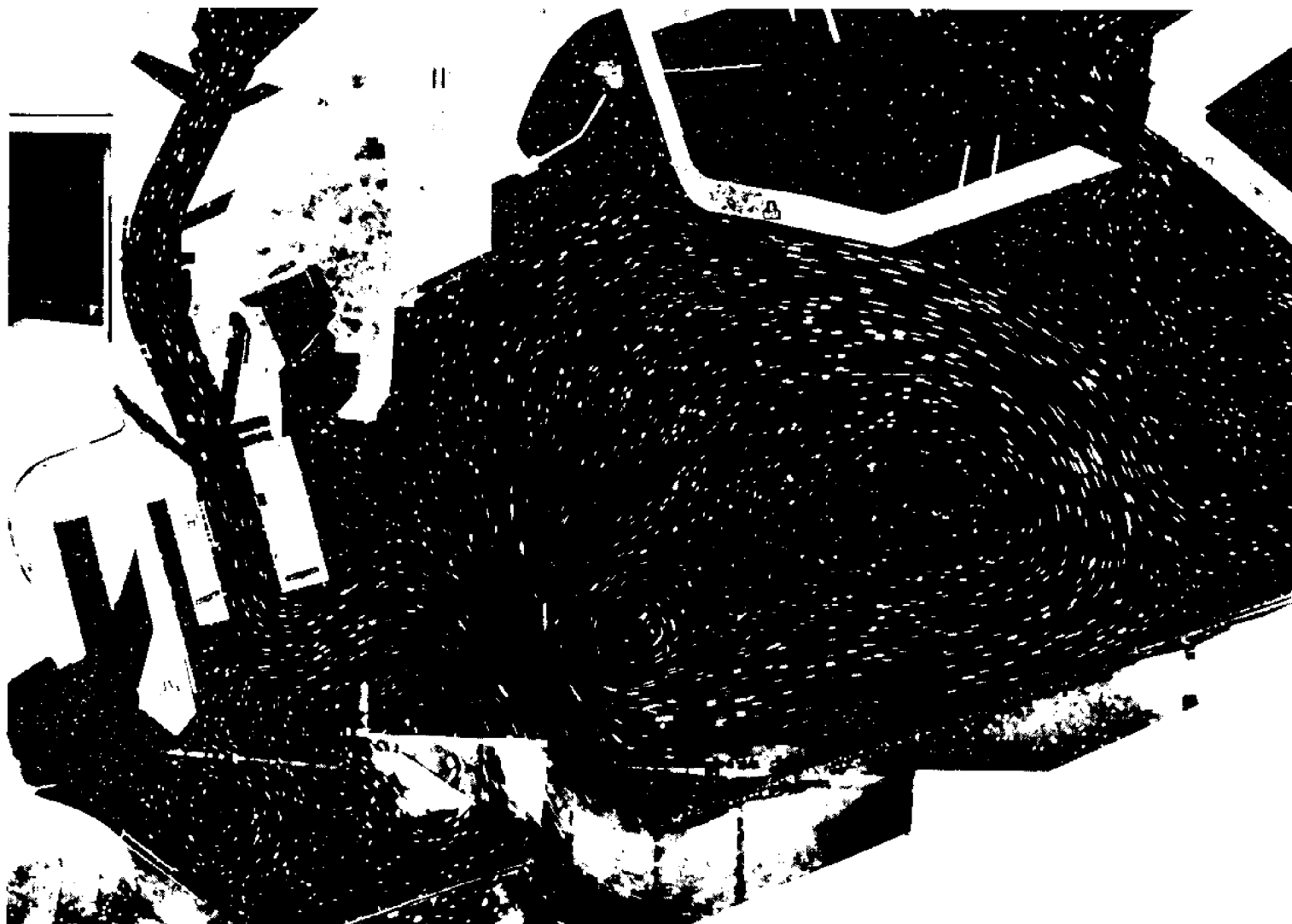

Edited by

Dorothy F. Soule and Mikihiko Oguri

Published by

Harbors Environmental Projects

Allan Hancock Foundation

and

The Office of Sea Grant Programs

Institute of Marine and Coastal Studies

University of Southern California

Los Angeles, California 90007

December, 1976

NATIONAL SEA GRANT DEPOSITORY
PELL LIBRARY BUILDING
URL. NARRAGANSETT BAY CAMPUS
NARRAGANSETT, RI 02882

Marine Studies of San Pedro Bay, California

Part 12

BIOENHANCEMENT STUDIES OF THE RECEIVING WATERS
IN OUTER LOS ANGELES HARBOR

Review of Field Observations
Assimilation Capacity/Oxygen Budget Modelling
Bioassay and Laboratory Investigations

Edited by

Dorothy F. Soule

and

Mikihiko Oguri

Published by

Harbors Environmental Projects
Allan Hancock Foundation
and
The Office of Sea Grant Programs

Institute of Marine and Coastal Studies
University of Southern California
Los Angeles, California 90007

December 1976
USC-SG-5-76



BIOENHANCEMENT STUDIES OF THE
RECEIVING WATERS IN OUTER LOS ANGELES HARBOR

by

Dorothy F. Soule and Mikihiko Oguri

EXECUTIVE SUMMARY

The receiving waters for fish cannery wastes in outer Los Angeles Harbor have been studied by Harbors Environmental Projects of the Allan Hancock Foundation, University of Southern California, since 1971. During that period, field investigations have been made of physical and biological parameters on a monthly basis, with specialized studies being carried out bi-weekly, weekly and daily during a portion of that time.

Physical conditions surveyed include circulation and flushing, temperature, dissolved oxygen, pH, salinity, turbidity, sediment character, pollutants, BOD and nutrients. Biological parameters include microbiology, phytoplankton productivity, zooplankton, benthic and water column invertebrates, fish and birds.

Laboratory studies have been carried out on bioassays, reproduction and growth, stress, toxicity, and food web relationships.

Mathematical modelling studies use the baseline data to relate the parameters to one another and work toward projection of organic loading in relation to assimilation capacity of the receiving waters.

The following statements summarize the information and conclusions derived from these investigations.

1. The field studies indicate that the present state of the

harbor is healthy. Rich and diverse biotic elements are supported by the present environmental regime. Episodes of stress, which occurred in earlier years, as indicated by reduced levels of dissolved oxygen, have not been noted since the canneries have instituted improved waste management procedures.

2. Bioenhancement (the enhancement of the biological quality of receiving waters) is occurring in outer Los Angeles Harbor, due at least in part to the presence of natural waste effluents.

3. Bioenhancement has been evaluated in terms of numbers of organisms and species diversity of plankton, benthic organisms, and standing crop of fish, as well as in biomass and a number of other factors detailed in the research reports.

4. The fish populations are higher in the outer harbor than in any other local coastal area in southern California. The harbor is an essential nursery grounds for the 0-1 year age class of anchovy and for other fish species.

5. Under present conditions, a small zone within approximately 200 feet of the outfalls exists where numbers of species are low. Adjacent to this zone is a zone of enrichment which extends through most of the outer harbor. Beyond that, conditions return to average coastal populations. The regulation of waste loading and control of pollutants in the past six-year period has brought the harbor ecosystem from a depauperate biota to a moderately rich one in the immediate outfalls zone, with a very rich biota in the adjacent outer harbor area.

6. There is a net bioenhancement over and above those

conditions which would occur in the absence of the existing natural waste discharges.

7. Cessation of all effluents would probably cause a gradual or accelerated reduction in the biota and ecosystem. Such phenomena have been documented in the United States and elsewhere; e.g., the Aswan Dam has caused a severe reduction in the Mediterranean fisheries.

8. The organic load from the cannery wastes puts a high Biological Oxygen Demand (BOD) on receiving waters. At the same time the BOD represents high nutrient input to the ecosystem, provided that sufficient dissolved oxygen is available to prevent reduced water quality.

8. Management strategies can be developed to predict generally the amount of loading possible under various environmental conditions. Mathematical model studies of the harbor based on the data being collected, suggest that the assimilation capacity of the receiving waters is not being exceeded by the organic load discharged in these waters. The model studies are being further developed to reflect short-term stress and change.

9. A more limited biota, tolerant to the effluents, is found in a relatively small area near the discharge points. Harbor organisms more sensitive to the effects of the effluent are not usually found there and on laboratory testing are unable to survive in high concentrations of the effluent.

Recommendations

1. Mitigating measures can be developed which would reduce or eliminate the zone of reduced productivity at the immediate outfall sites. Several possibilities have been suggested and should be investigated.

2. Effluents should be analyzed and bio-tested to determine whether current processing methods cause toxic factors to be present some, or all, of the time in existing effluent concentrations.

3. Further development of the mathematical model should be continued to establish its utility as a management tool.

TABLE OF CONTENTS

Executive Summary	i
Bioenhancement Studies of the Receiving Waters in Outer Los Angeles Harbor, by Dorothy F. Soule and Mikihiko Oguri	3
Part A. Quantification of the Assimilative Capacity of Outer Los Angeles Harbor; A Dynamic Oxygen Model, by J. Stanley-Miller, Patricia Kremer and Wen-Li Chiang	59
Part B. The Food Habits of Marine Fish in the Vicinity of Fish Harbor in Outer Los Angeles Harbor, by Donald J. Reish and Richard Ware	113
Part C.I. The Energetic Role of Amino Acid and Protein Metabolism in the Kelp Bass (<i>Paralabrax clathratus</i>), by Karen Bever and Arnold Dunn	129
Addendum: Preliminary Note: Direct Uptake of Amino Acids by the Gut of the Kelp Bass, <i>Paralabrax clathratus</i> , by Karen Bever and Arnold Dunn	143
II. The Protein Content of Seawater in Outer Los Angeles Harbor, by Karen Bever	145
III. The Amino Acid Content of Seawater in Outer Los Angeles Harbor, by Sidney Chao	159
Part D. The Effects of Waste Effluents on Fish Populations in the Los Angeles Harbor, by Gary D. Brewer	165
I. Bioassay Studies of Fish	169
Addendum: Fish Cannery Waste Bioassay with <i>Fundulus parvipinnus</i>	190
II. Enhancement Studies: a) Zooplankton; b) Fishes	193

TABLE OF CONTENTS (cont.)

Part E.I.	Bioassay Investigations of the Impact of Wastes on the Copepod <i>Acartia tonsa</i> , by John R. McConaugha	215
II.	Microheterotrophic Uptake of Organics in Seawater, by John R. McConaugha	226
Part F.	Impact of Discharges from the Main Cannery, StarKist and the Terminal Island Waste Treatment Plant on the Ecology of Outer Los Angeles Harbor, by Ray R. Emerson	233
I.	Impact of Cannery and TITP Wastes in the Receiving Waters on Certain Marine Invertebrates: a) Bioassay; b) Bioenhancement	236
II.	Effects of Secondary Waste Treatment and Chlorination on Selected Invertebrates	247
III.	The Impact of Cannery Wastes on Primary Productivity in the Receiving Waters	255
Part G.	Phytoplankton Studies: Progress Report, by Gregory Morey-Gaines	269
Errata	279

Cover photo: Tidal flow in the physical model of outer Los Angeles-Long Beach Harbors.
Courtesy of the U.S. Army Engineers
Waterways Experiment Station.

BIOENHANCEMENT STUDIES OF THE
RECEIVING WATERS IN OUTER LOS ANGELES HARBOR

by

Dorothy F. Soule and Mikihiko Oguri

INTRODUCTION

The premise that waste effluents from domestic sewage and from food processing plants may enhance the ecosystems of marine waters is not unique to the case of the Terminal Island effluents in outer Los Angeles Harbor. However, documentation of cannery waste fields is scarce, while sewer outfalls have been more extensively studied. Empirical evidence of enhancement is often observed; by the shore anglers who fish with unbaited gang hooks beside the outfall pipes at Terminal Island, by the sport fishing party boats that regularly anchor near the local ocean sewer outfalls, and by the fishing birds such as pelicans that dive repeatedly into the plume areas to capture fish attracted to the food source.

Locally, field studies of receiving waters around ocean outfalls have been carried on at Hyperion (Los Angeles City) in Santa Monica Bay, at Whites Point (Los Angeles County) off Palos Verdes Peninsula, at the Orange County outfall, and at Avalon, on Santa Catalina Island. The Allan Hancock Foundation first studied Hyperion in 1946-47, and covered the entire coast of southern California beyond about the 100 ft contour (AHF, 1965) where waste fields occur. The Southern California Coastal Water Research Project was initiated in 1969 by the Cities of Los Angeles and San Diego, the Sanitation Districts of Los Angeles

and Orange County and by Ventura County, to study the receiving waters and the impacts of waste input. A number of specialized studies and reports have originated from that group. Bascom (1974, 1976) wrote on waste disposal in the ocean and noted the zone of enhancement that lies outside the immediate zone of impact of the discharge. D. J. Reish and his associates at California State University, Long Beach, and Emerson (1974) documented the biostimulatory effects of certain dilute concentrations of wastes.

The evidence for bioenhancement in Los Angeles Harbor is of several sorts. In the sections following, under Background Investigations, the information developed from studies carried out in the last five years is reviewed and summarized. In the appendices, separate research reports by several investigators contain the indications for enhancement, and also point out some of the problem areas.

It appears that the problems associated with the cannery wastes are minor ones which could be ameliorated by strategies such as dilution of the effluent with ambient sea water, modification of the outfall pipes, and continued management of total loading.

The possible impact of treatment methods such as the Dissolved Air Flotation (DAF) unit and mitigating measures to control the minor incidence of mortality in the more delicate species should be investigated.

The trophic structure is still not known in sufficient detail to quantify precisely the optimal level of BOD. It is essential that these studies be pursued to result in a management tool for

maintaining environmental quality. Results, when refined through computer, field and laboratory verification, should be applicable to other fish cannery waste sites, and to the food industry in general.

The present study is funded in part by the Tuna Research Foundation, representing the local canners StarKist, Van Camp and Pan Pacific (CHB), plus Neptune and Del Monte. Other participants in the cooperative effort are the City of Los Angeles Department of Engineering for the Sanitation District, plus the University of Southern California's Office of Sea Grant Programs (U.S. Department of Commerce) and Harbors Environmental Projects (Allan Hancock Foundation and the Institute of Marine and Coastal Studies).

Previous studies in the harbor, reported under Background Investigations, were carried out in cooperation with the U.S. Army Corps of Engineers, Los Angeles District, USC-Sea Grant Program, Los Angeles Board of Harbor Commissioners, Pacific Lighting Corporation (Southern California Gas Company), Tuna Research Foundation, StarKist Foods, and other local entities and agencies.

BACKGROUND INVESTIGATIONS

The degree to which field conditions in the Los Angeles Harbor receiving waters for the Terminal Island cannery wastes have been documented is perhaps unique. Probably no other cannery waste fields have been as extensively studied, because of cooperative

efforts there by local industries, public agencies, and Harbors Environmental Projects (HEP) of the University of Southern California. For more than five years, monthly monitoring of seven outer harbor stations for temperature, salinity, oxygen, pH, turbidity, phytoplankton productivity, zooplankton species and numbers, and midwater fauna has been carried out, along with quarterly benthic sampling, seasonal fish trawls and oceanographic studies. During 1973 and 1974, the studies were expanded to include the entire Los Angeles-Long Beach Harbors area to the southeast of the San Gabriel River mouth. Parameters sampled were increased to include microbiology, sedimentology, sediment chemistry and pollutants, and weekly observations of marine birds. These efforts have been supported in part by the USC-Sea Grant Program (Department of Commerce), the Army Corps of Engineers, and Pacific Lighting Corporation.

In the immediate vicinity of Terminal Island, where the StarKist and Way Street Station cannery outfalls and the Terminal Island Treatment Plant outfall are located, biweekly monitoring of temperature, dissolved oxygen (DO), pH, salinity, color and biological oxygen demand (BOD) has been maintained at 22 surface and subsurface sampling stations for the Tuna Research Foundation. Figure 1 shows the monthly stations A1-A7 which were studied since 1971. The Tuna Research stations are shown on transects as 1A-4D, and 5A-6C.

The results of these and other studies have helped to form the basis of the conclusion that the natural wastes are important

to the local ecosystem. Several other HEP studies funded by the Los Angeles Harbor Department showed results that could be used to evaluate the question of enhancement. A drogue study (Soule and Oguri, 1972) described the presence of a large circulation gyre in the outer harbor which was confirmed by current meter studies (Robinson and Porath, 1974). The Army Engineer Waterways Experiment Station scale model in Vicksburg, Mississippi duplicated this gyre (McAnally, 1975). Another HEP study mapped trace metal and other pollutant concentrations in the harbor and in the San Pedro channel area (Chen and Lu, 1974). A further HEP study for the Los Angeles Harbor Department mapped the biomass distribution of benthic organisms in the outer harbor, measured for benthic recolonization potential and performed bioassays simulating the effects of resuspension of sediment (dredging or stirring) on representative harbor species.

Figure 2 shows the station pattern for the two-year study (Allan Hancock Foundation, 1975) which created a data bank and permitted computer analysis of multiple parameters. The Marine Studies of San Pedro Bay, California series (Soule and Oguri, eds., 11 volumes, 1972-1976) summarizes results.

In addition to the long-term studies, a number of short-term field investigations are currently underway, some results of which are discussed in subsequent sections of the present papers. Water quality measurements are also made at a number of stations from which receiving water samples are taken for laboratory tests.

Circulation and Flushing

The existence of the large gyre in outer Los Angeles Harbor appears to serve as a natural oxidation pond, which allows the reduction and recycling of the nutrients in the wastes to take place in a balanced system. The cannery wastes are composed of natural proteins, carbohydrates and fats, which can be incorporated into the ecosystem food web. The sewage wastes from Terminal Island Treatment Plant (primary treated effluent) are also largely natural substances, although industrial and storm drain wastes have carried large amounts of trace metals and other pollutants into the harbor.

In the past, when unlimited dumping was permitted in the harbor prior to regulatory actions, flushing was inadequate to supply sufficient dissolved oxygen for the heavy biological and chemical oxygen demand (BOD, COD). Since the efforts of the State and Regional Water Quality Control Board were initiated to monitor receiving water quality, and industry has upgraded the management and treatment of wastes, the quality of the receiving waters, and hence the ecosystem, has improved.

The circulation patterns in the harbor, as shown in the model studies, are presented in Figures 3 and 4 (McAnally, 1975). These can be compared with the only previously published illustration of the harbor before the extensive Pier J landfill (Figure 5, adapted from Reish, 1959). Flushing was quite different in the harbor, and the gyre was not apparent. Circulation now appears to be strongly wind-driven in the outer harbor.

The combinations of circulation, flushing and nutrients, plus the reduction in toxic wastes, has led to the apparently steady improvement in the quality of marine life that was revealed by the biological investigations detailed in the subsequent sections.

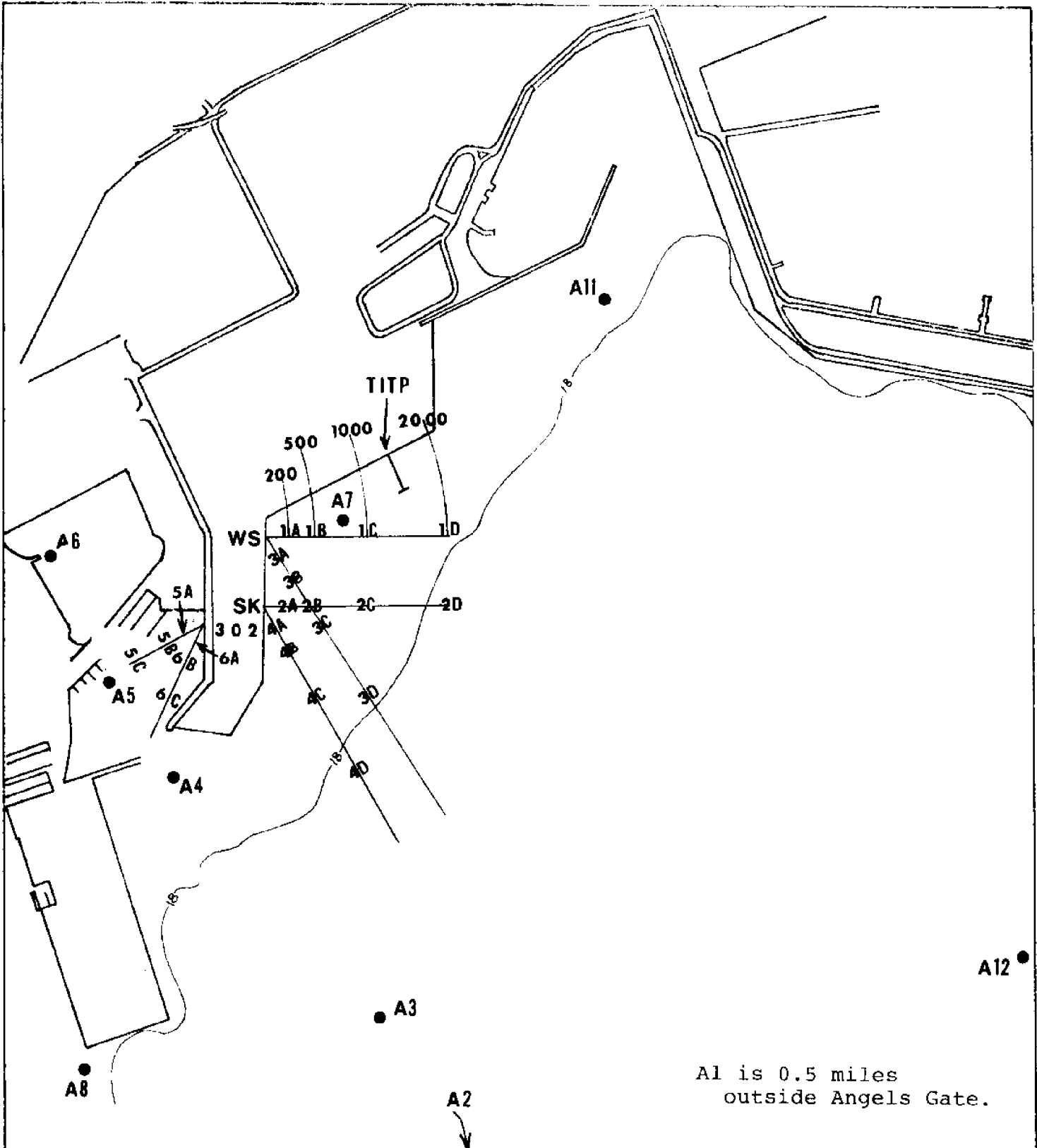

Figure 1. Water Quality Monitoring Stations in Effluent Area.

Tuna Research Foundation: 1A - 4D

Pacific Lighting Corporation: A1 - A7

(distance in feet)

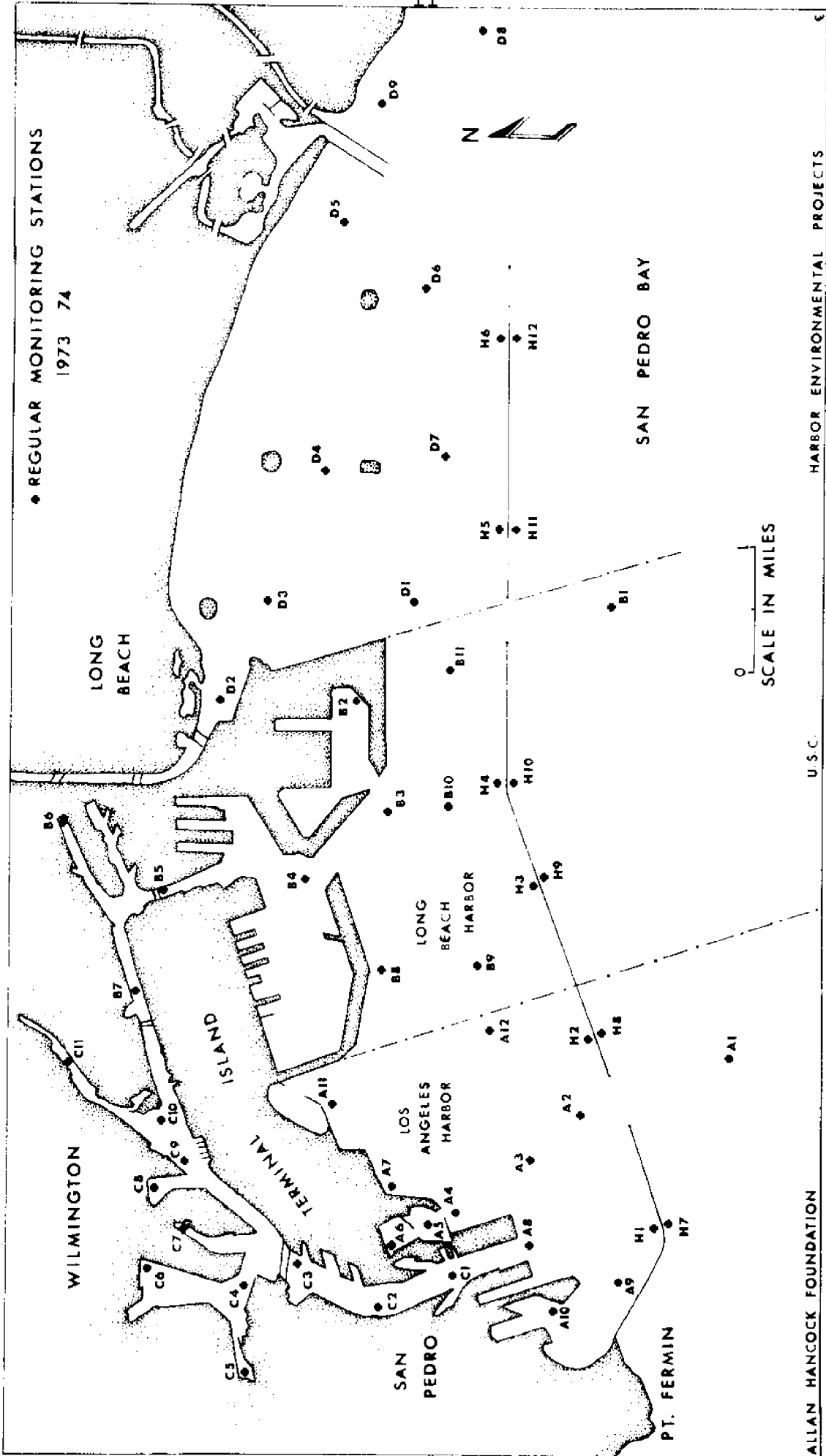
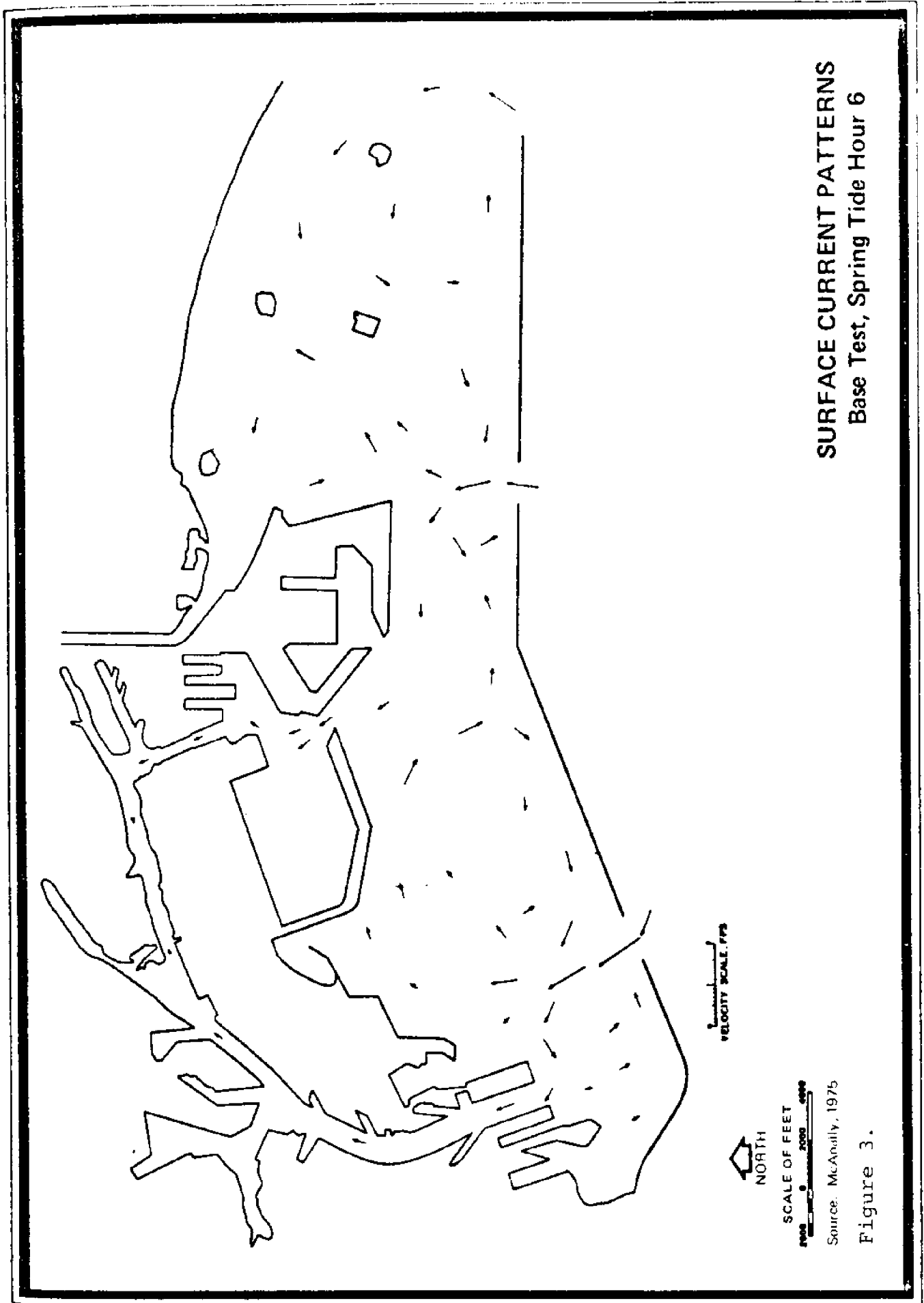

Figure 2. Monthly Monitoring Station, 1973 and 1974.



SURFACE CURRENT PATTERNS
Base Test, Spring Tide Hour 6

VELOCITY SCALE: fms



NORTH

SCALE OF FEET



Source: McAnally, 1975

Figure 3.

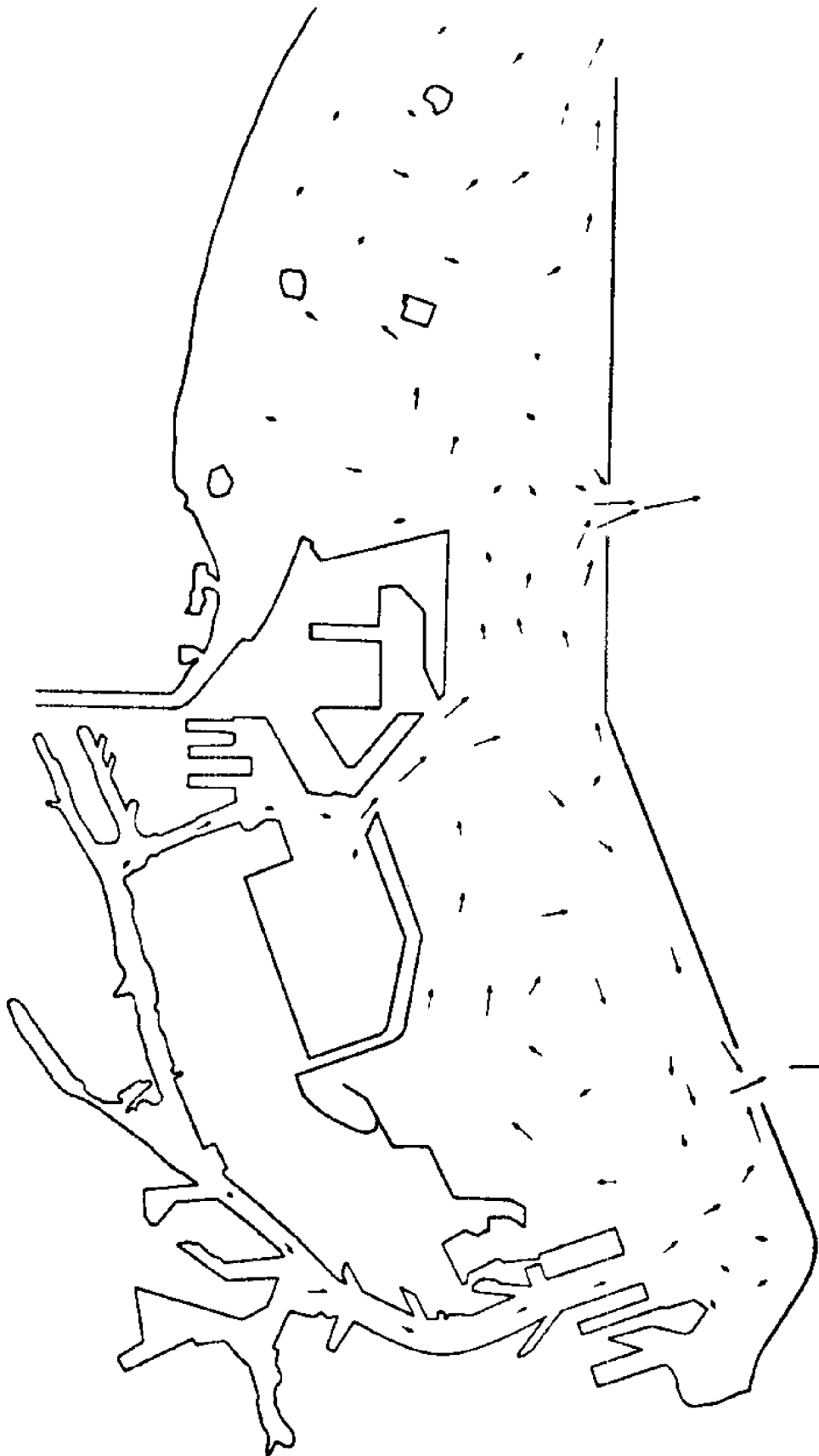

SURFACE CURRENT PATTERNS
Base Test, Spring Tide Hour 13

VELOCITY SCALE, FPS

NORTH

SCALE OF FEET



Source: McAnally, 1975

Figure 4.

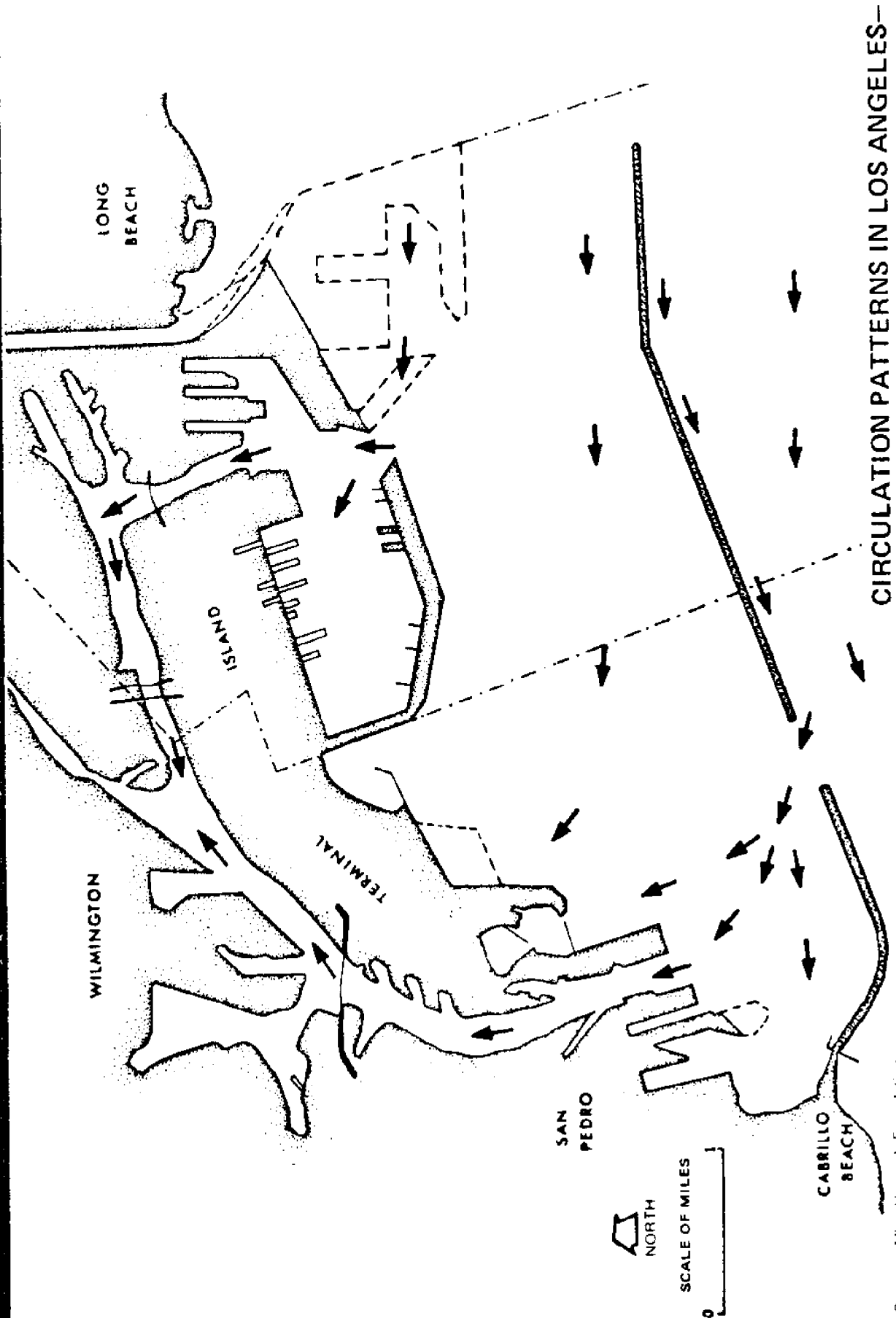

CIRCULATION PATTERNS IN LOS ANGELES—
LONG BEACH HARBORS

Figure 5.

Source: Allan Hancock Foundation
Reference: Rehn, 1959

Benthic Animal Life

During the Harbors Environmental Projects 1973-74 study, benthic samples were taken at quarterly intervals throughout the harbor at 42 stations. The numbers of species present (species diversity) and the numbers of individuals combine to give a good indication of the health of the benthos. Reduced species diversity, even when the species occur in very large numbers, is an indication of a stressed environment. Reduced diversity and reduced numbers (production) together indicate a poor quality of environment due to stress or to unsuitable substrate. Figure 6 shows the mean numbers from representative boxcorer samples, with species/numbers taken per 1/16 sq. meter sample per station. The A1 and B1 stations outside the breakwater can be taken as a comparative standard, with more than 50 species. The innermost harbor slips and channels show fewer than 50 species; the lowest at C11 in Dominguez Channel (Consolidated Slip) was 6 species.

Numbers extrapolated to counts per square meter ranged from 1600-6400 in inner slips. Counts of 8000 and 14,000 occurred at A1 and B1 respectively, outside the harbor. Most main channel stations had 30-40 species and 6400 to 26,000 individuals per square meter.

In the outer harbor, only A4, A5 and A6, enclosed areas associated with Fish Harbor, had low species diversity and low numbers. At A7, between cannery and sewer outfalls, the counts of numbers of individuals were better than several main channel

stations. In the rest of the outer harbor, most stations had above 50 species and the individual counts ranged up to 76,000, or 6 to 10 times the numbers of individuals at A1 and B1.

It cannot be said that this bioenhancement is due solely to waste effluents, for the finer sediments in the harbor and the limited wave action provide a suitable substrate. However, it can be said that the counts would not be so high if the environment were as stressed as it is in the inner slips, where reduced flushing and higher temperatures may deplete the bottom dissolved oxygen, or residual industrial wastes may be inhibitory.

By way of comparison with another outfall, a study by SCCWRP of sludge in the waste field of Hyperion Treatment plant in Santa Monica Bay found 24 species of benthic animals and 16,000 individuals per square meter in the sludge bed (Bascom, 1976). The number of species and individuals there were much reduced as compared with the area of bioenhancement in outer Los Angeles-Long Beach Harbors. The number of individuals near Hyperion was higher than those in Fish Harbor and the inner harbor slips, and quite similar to those at A7, between the Terminal Island Treatment Plant and cannery effluents in the outer harbor. The average for the entire Los Angeles-Long Beach Harbor was 28 species, and 80,000 individuals per square meter (AHF, 1975).

An examination of Reish's data from the harbor in 1954 (Figure 7) shows the areas sampled and the classification of the sediments according to indicator species he selected (Table 1). He did not sample a large part of the area of outer Los Angeles

that can presently be considered the zone of enhancement. However, the figure and table show that the most polluted zone then was devoid of macroscopic life, a condition which does not now exist in the harbor. Table 1 also compares Reish's data with HEP (AHF, 1975) data, and Figure 8 shows the classifications developed in that study.

Table 1. Comparisons of Indicator Organisms Used by Various Authors to Classify Levels of Pollution in the Harbor

Very Polluted	Polluted	Semi-healthy II	Semi-healthy I	Healthy
	<i>Capitella capitata</i>	<i>Cirriiformia luxuriosa</i>	<i>Polydora pauetbranchiata</i> <i>Schistomerings longicaornis</i>	<i>Tharyx ? parvus</i>
"Polluted" (station 24)				
	<i>Capitella capitata</i> <i>Capitella ambiseta</i> <i>Polydora ligni</i>			<i>Tharyx parvus</i> <i>Cosaura candida</i> <i>Haploecoloplos elongatus</i>
	Group Z <i>Capitella capitata</i> <i>Armandia bioculata</i> <i>Polydora ligni</i> <i>Pseudopolydora pauetbranchiata</i>	Group Y <i>Schistomerings long.</i> <i>Capitella capitata</i> <i>Ophiodromus pugetten.</i> <i>Theora lubrica</i>	Group X <i>Euchone limicola</i> <i>Callianassa</i> <i>Cryptomya calif.</i> <i>Nephtys o. frana.</i>	Group W <i>Tharyx ? parvus</i> <i>Cosaura candida</i> <i>Haploecoloplos elongatus</i> <i>Prionospio pinn.</i> <i>Tellina modesta</i>
		Group I <i>Tharyx</i> <i>Cosaura candida</i> <i>Capitellidae*</i> <i>Euphilomedeae</i>	Group II <i>Tharyx</i> <i>Cosaura candida</i> <i>Paranais g. oculata</i>	Group III <i>Tharyx</i> <i>Cosaura candida</i> <i>Paranais g. oculata</i>
				Group IV <i>Tharyx</i> <i>Euphilomedeae</i> <i>Carcharodonta</i> <i>Capitellidae*</i> <i>Euphilomedeae</i>

Reish, 1959 →

Hill, 1974 →

NY, 1975 →

MBC, 1975 →

* *Capitella ambiseta* and *Mediomastus*.

Benthic Biomass

The body weight, or biomass, of benthic organisms can also be used as an indicator of environmental quality, although presence of a few large individuals can create a misleading impression on occasion. In a study of the outer Los Angeles Harbor proposed LNG channel area (Figure 9) biomass measurements were made in 1975 and 1976. Results indicated that within approximately the 18-foot contour closest to the waste outfalls and the shore, there was a zone of relatively low productivity or biomass (grams per square meter). In the outer harbor area studied, a zone of relatively high productivity was delineated (Figure 10). This study confirmed the distribution of species and numbers found in the earlier study (Figure 6) for part of the area of the waste effluent field.

In a series of field experiments (HEP, 1976) racks of jars containing newly-exposed dredged surface sediments were placed at five locations (Figure 9, R symbols). Although many of the jars were destroyed, presumably by ships' anchors, vandalism, or storms, evidence of good potential for recolonization was gained (Table 2).

In the winter-spring periods of exposure, the best biomass gain was at LNG 18 and R4, just east of the TITP outfall and well within the zone of influence of the cannery wastes, where waters were warmer.

In the summer, the shallow water stations showed very much higher biomasses than the stations nearer the breakwater. This contrasts considerably with the biomasses and benthic samples taken from the sediments directly by grab sampler or boxcorer.

Since the recolonization jars are deployed by divers in racks on the bottom sediments, the difference may lie in the shelter provided above the sediment by the jars.

Taken alone, the recolonization data were too few to quantify the distribution patterns accurately. However, they do provide evidence that the receiving waters and sediments are not toxic, but are really quite productive.

Table 2. Recolonization Biomasses with Seasonal Abundances Indicated.
(grams/sq. meter)

1975 Stations	6 weeks						12 weeks			18 weeks		24 weeks
	Feb.- March	May- June	June- August	Aug.- Sept.*	Feb.- May	April- June	May- August	Feb.- June	May- Sept.*	Feb.- August		
LNG 1 C		○ 1.8	○ 25.6	○ 0.205			● 46.1					
Recol 1 E		○ 3.5	○ 16.9	○ 0.175			○ 14.4					
LNG 3 C		○ 2.9	● 32.3	○ 0.30			○ 27.0					
Recol 2 E		○ 2.3	● 73.4	○ 0.62			● 50.5					
LNG 5 C	○ 11.8	○ 4.7	● 35.0		○ 14.1	○ 2.6		○ 2.9	○ 0.2	○ 12.0		
Recol 3 E	○ 24.7	○ 6.6	● 37.6		○ 14.1	○ 0.9		○ 3.5	○ 0.35	○ 26.7		
LNG 18 C	● 57.6	○ 8.8	■ 131.9		● 35.2	○ 0.6		○ 23.5	■ 139	■ 161.6		
Recol 4 E	● 48.1	○ 10.4	○ 22.9		○ 10.6	○ 5.9		○ 17.0	■ 162.4	■ 135.0		
LNG 24 C	○ 16.5	○ 10.6	● 60.8		○ 15.3	○ 7.1		○ 8.8		○ 36.7		
Recol 5 E	○ 17.0	○ 6.2	● 80.2		○ 7.6	○ 5.3		○ 8.8		■ 162.4		
Average	29.28	16.4	51.6		16.5	3.73	34.5	10.85		89.6		

○ 0 - 9 ● 30 - 39 ● 60 - 69 ■ 90 - 99

○ 10 - 19 ● 40 - 49 ● 70 - 79 ■ 100 (* One sample only)

○ 20 - 29 ● 50 - 59 ● 80 - 89

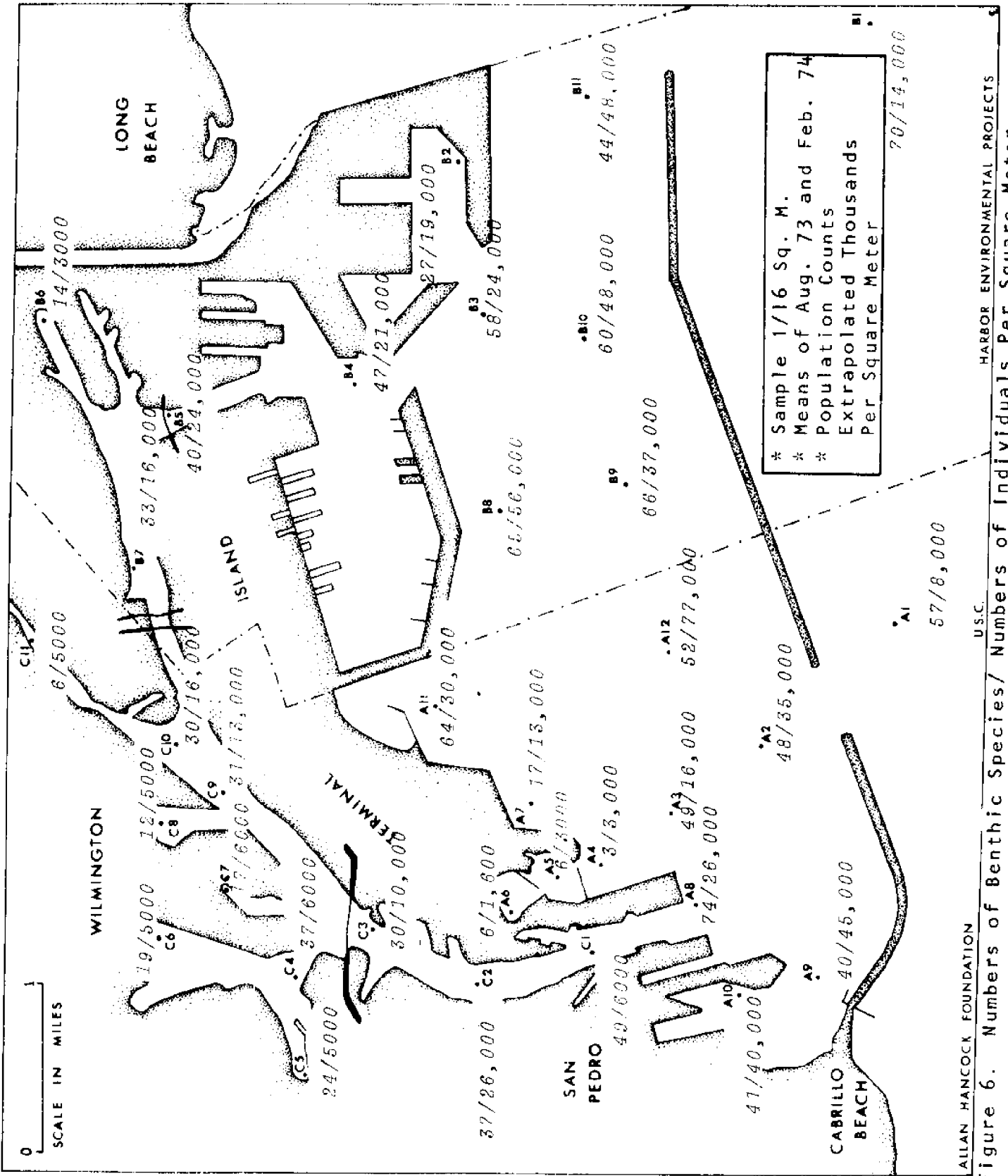

Figure 6. Numbers of Benthic Species/ Numbers of Individuals Per Square Meter

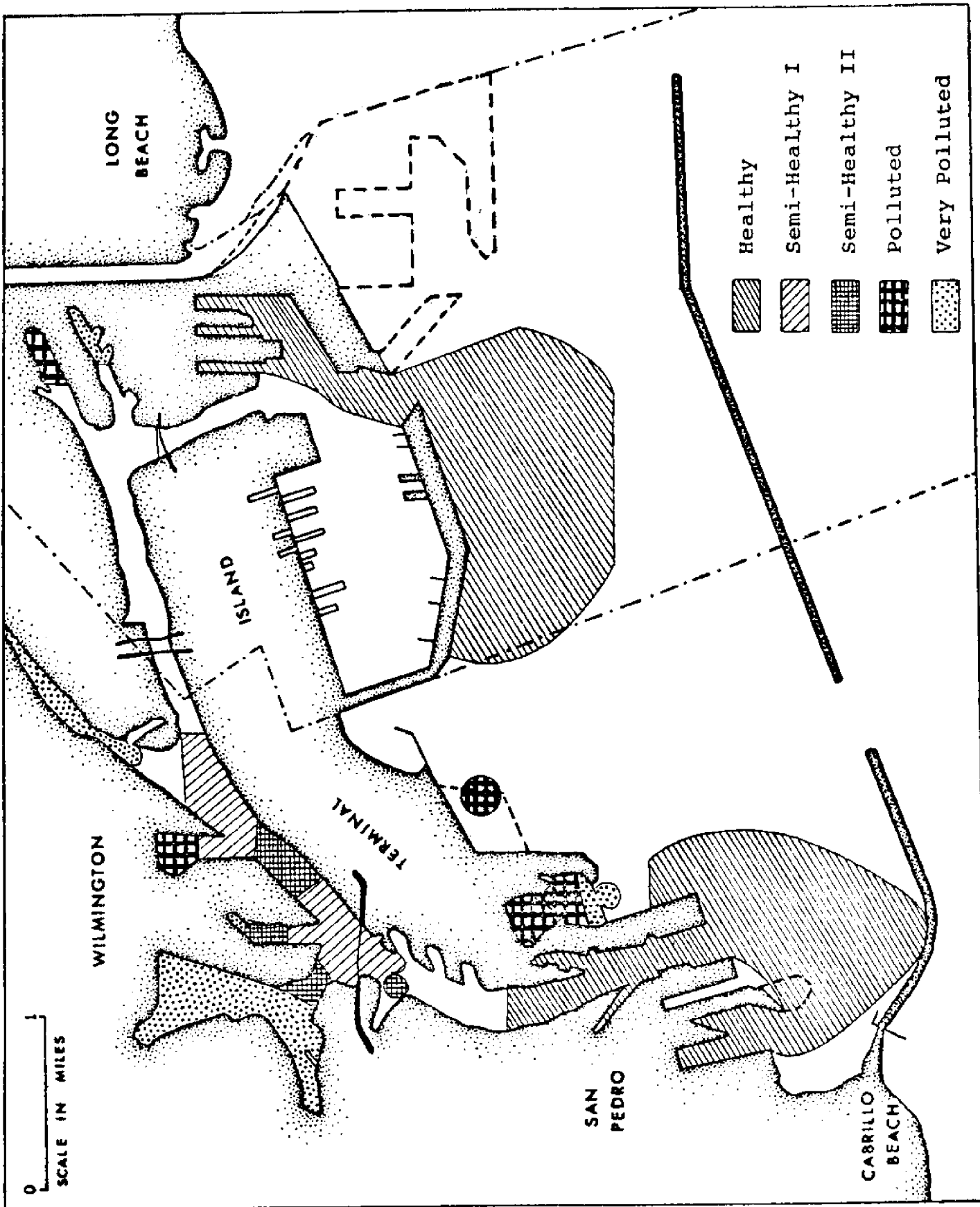
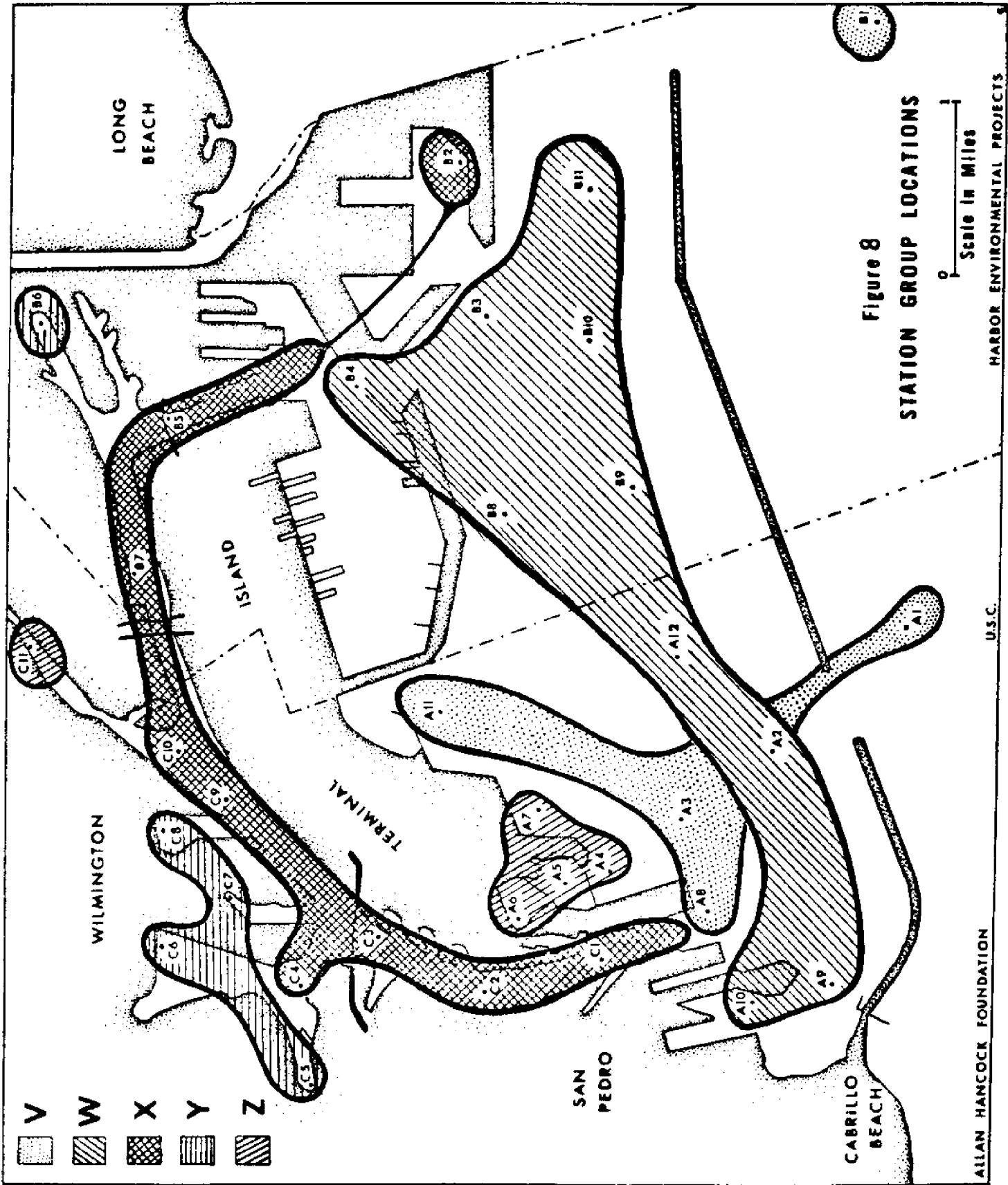

Figure 7. Location of Pollution Zones - June, 1954. (from Reish, 1959).



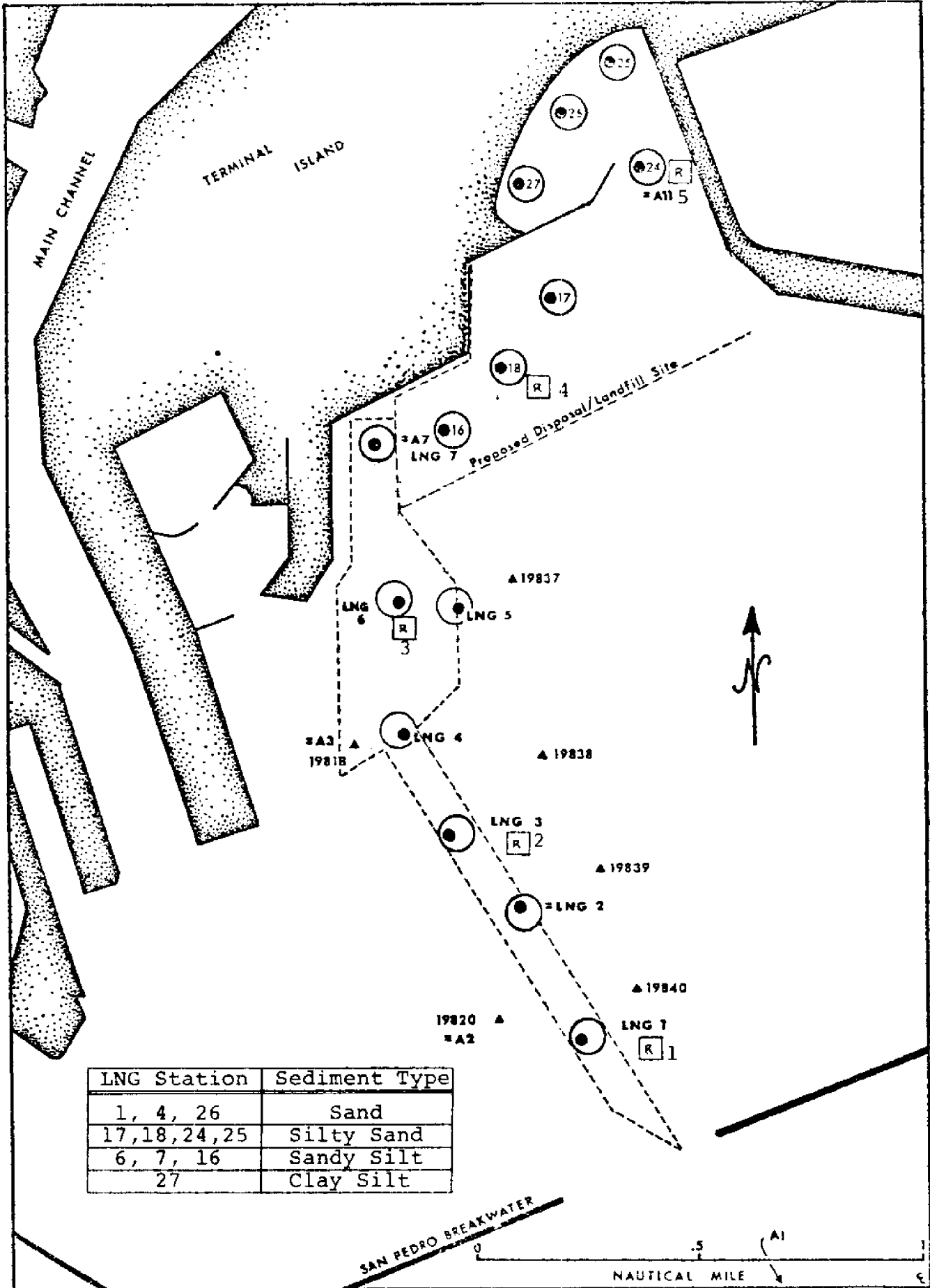
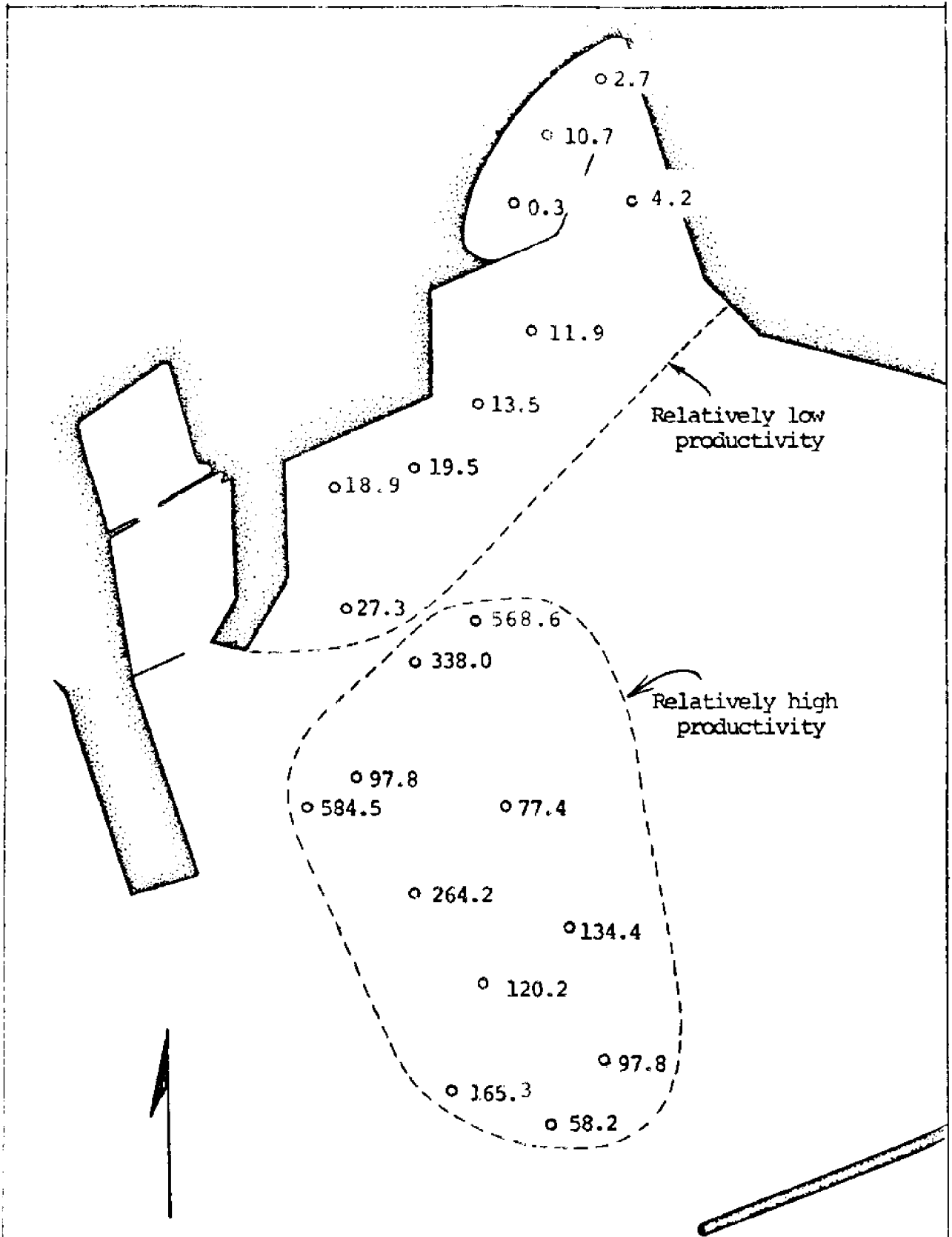

Figure 9 . Outer Los Angeles Harbor Dredging Effects Study (Harbor Environmental Projects, 1976).



Source: Marine Studies of San Pedro Bay, Calif. 1976. Part 11.
 Figure 10. Animal Biomass in g/m² at the Benthic Stations.

Phytoplankton Productivity

Phytoplankton productivity, photosynthetic pigments and assimilation ratio in the general area of the outfalls have been monitored monthly since 1971 as part of the various studies mentioned above. These measurements offer an indication of the fertility of the associated waters in terms of how much organic material is being produced by photosynthesis and how large a population of phytoplankton is involved in the production.

Data on annual average productivity, chlorophyll *a* and assimilation ratio for the years 1973 and 1974 are reproduced from the AHF (1975) report to the Corps of Engineers as Figures 11 to 16. The area around the outfalls showed moderate levels of productivity and chlorophyll *a*, with somewhat higher values than for the stations outside the harbor. Assimilation ratios, a measure of productivity per unit of population, showed patterns reflecting the enrichment associated with the effluents. Higher assimilation ratios were found in and around the outfalls area than in many other areas, though they were not the highest found in the harbor.

Seasonal variations in these measurements (Soule and Oguri, 1973; Oguri, 1974) were similar in pattern to those occurring offshore, but varied in magnitude. A spring bloom, primarily of diatoms, showed higher values of productivity, pigments and assimilation ratio. In the summer and fall, secondary peak blooms occurred, usually of dinoflagellates. These were followed by the minimum values found in winter. The secondary blooms in 1971 through 1974 were notably more intense and longer lasting than those occurring in 1975 and 1976. This may be due to the institution of more rigid

waste discharge requirements imposed on the canners by the Regional Water Quality Control Board and also to decreased rainfall and milder temperatures than prevailed in the earlier years. The years 1973 and 1974 are the only ones for which comparable data for the entire harbor are available. In the other years the data collected were primarily for outer Los Angeles Harbor.

Zooplankton

Zooplankton in the Los Angeles-Long Beach Harbor has been reported on in the recent past by the Allan Hancock Foundation (1975) after conducting a two-year survey of the entire harbor for the Corps of Engineers and others in 1973 and 1974.

The zooplankton of the harbor consists, essentially, of two distinct populations. In the inner harbor population levels are generally more sparse than in the outer harbor. However, the dominant species, the copepod *Acartia tonsa*, comprises 60% to 80% of the total population in the inner harbor and also is prominent in the outer harbor. *Oithona oculata*, a cyclopoid copepod, also is found in abundance in the inner harbor but is much less apparent in the outer harbor. The cladocerans *Podon polyphemoides* and *Evadne nordmanni* are restricted almost exclusively to stations in the outer harbor.

Figures 17 to 21 show computer maps of population densities based on settling volume for 1973 and 1974. In both years populations in the outer harbor were higher than those found in the inner harbor. The highest population densities for both years occurred in the area near the outfalls. This may reflect the enrichment provided by the effluents.

Table 3. Table 3 shows the seasonal variation in productivity, chlorophyll *a* and assimilation ratio during 1973.

ABIOTIC TABLE FOR THE YEAR 1973: PRODUCTIVITY, CHLOROPHYLL A, AND ASSIMILATION RATIO
STATIONS A1 THROUGH D8 BY MONTH

	JAN	FEB	MARCH	APRIL	MAY	JUNE	JULY	AUG	SEPT	OCT	NOV	DEC
A1	***** ***** *****	3.70 1.77 2.08	4.40 2.10 2.10	10.30 4.82 2.13	3.00 ***** *****	3.30 1.30 2.54	38.20 6.37 5.99	10.60 1.07 9.85	9.10 2.55 3.57	15.30 2.62 5.83	7.50 ***** *****	29.30 7.92 3.70
A2	***** ***** *****	8.40 2.00 4.20	14.20 5.42 2.62	10.80 5.05 2.14	33.10 18.07 1.83	30.10 12.45 2.42	61.80 11.97 6.83	69.10 9.40 9.48	29.10 5.47 5.32	12.70 5.07 2.50	19.80 3.37 5.87	31.20 6.62 4.71
A3	***** ***** *****	3.70 1.17 3.15	18.70 7.92 2.36	15.60 6.90 2.26	30.60 18.42 1.66	21.20 7.95 2.67	134.90 17.30 7.80	76.20 10.67 7.14	131.40 15.32 8.57	9.60 4.47 2.15	44.20 6.15 7.19	50.20 11.00 4.56
A4	***** ***** *****	2.00 1.25 1.60	16.70 9.02 1.85	4.60 2.82 1.63	20.20 13.75 1.47	35.90 21.85 1.64	159.70 18.47 8.64	76.60 10.90 7.03	107.60 15.30 7.03	4.80 3.70 1.30	14.60 2.30 6.35	32.90 10.05 3.27
A5	***** ***** *****	3.30 1.40 2.36	25.00 8.90 2.81	11.30 8.00 1.41	14.70 6.60 2.23	31.30 20.00 1.56	138.30 17.32 7.98	108.60 19.10 5.69	44.90 6.05 7.42	1.30 2.32 0.56	31.00 7.10 4.37	51.00 11.90 4.29
A6	***** ***** *****	3.60 1.50 2.40	19.70 10.70 1.84	16.50 9.67 1.71	17.90 3.22 5.55	56.40 33.13 1.70	104.60 17.52 5.97	66.90 13.75 4.87	38.90 8.35 4.66	1.30 2.92 0.44	76.80 10.97 7.00	43.10 14.15 1.05
A7	***** ***** *****	1.80 2.77 0.65	10.50 6.60 1.59	1.20 3.35 0.36	1.40 21.85 0.06	45.20 29.25 1.55	31.30 7.77 4.03	15.20 5.87 2.59	77.20 8.80 8.77	1.40 3.20 0.44	14.40 1.77 8.11	***** ***** *****
A8	***** ***** *****	2.80 1.45 1.93	4.40 2.32 1.89	7.10 3.22 2.20	9.20 4.95 1.86	29.00 9.90 2.93	105.30 16.10 6.54	68.10 9.50 7.17	38.00 5.90 6.44	1.50 1.42 1.05	20.30 11.85 1.71	23.00 5.75 4.00
A9	***** ***** *****	7.10 2.17 3.26	13.50 4.82 2.80	6.50 2.97 2.18	10.90 4.50 2.42	***** 10.35 *****	117.10 18.52 6.32	48.40 8.92 5.42	25.30 3.82 6.61	4.50 2.02 2.22	23.90 4.00 5.94	30.20 8.30 3.64
A10	***** ***** *****	2.60 0.87 2.97	5.00 1.35 3.70	5.50 2.50 2.20	8.00 3.32 2.41	13.80 3.67 3.76	130.70 17.40 7.51	46.50 10.27 4.53	29.90 3.92 7.62	7.20 2.40 3.00	51.30 9.40 5.46	38.90 6.70 5.81
A11	***** ***** *****	1.80 1.07 1.67	13.90 5.67 2.45	9.80 5.22 1.88	20.80 10.22 2.03	25.60 27.35 0.94	51.30 10.37 4.94	74.60 10.82 6.89	64.50 15.30 4.22	8.20 ***** *****	150.80 10.72 14.00	11.60 10.22 1.13

VALUES OF ***** REPRESENT DATA NOT AVAILABLE

Figure 11.

Mean Productivity, 1973

ABSOLUTE VALUE RANGE APPLYING TO EACH LEVEL
(*MAXIMUM* INCLUDED IN HIGHEST LEVEL ONLY)

MINIMUM	9.47	15.08	21.68	28.09	34.30	40.51	45.72	52.92	59.13	65.34
MAXIMUM	16.68	21.88	28.09	34.30	40.51	46.72	52.92	59.13	65.34	71.55

PERCENTAGE OF TOTAL ABSOLUTE VALUE RANGE APPLYING TO EACH LEVEL

10.00	10.00	10.00	10.00	10.00	10.00	10.00	10.00	10.00	10.00	10.00
-------	-------	-------	-------	-------	-------	-------	-------	-------	-------	-------

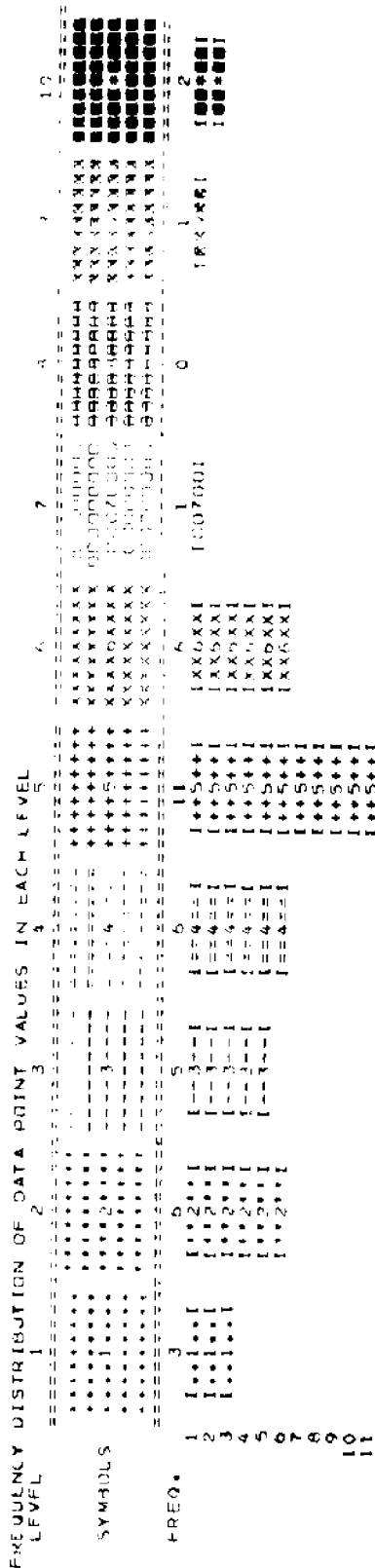



Mean Productivity - 1973

Figure 11

Figure 12.

Mean Productivity, 1974

ABSOLUTE VALUE RANGE APPLYING TO EACH LEVEL
 (*MAXIMUM INCLUDED IN HIGHEST LEVEL ONLY)

MINIMUM	11.22	22.80	34.38	45.95	57.53	69.11	80.69	92.27	103.85	115.43
MAXIMUM	22.80	34.38	45.95	57.53	69.11	80.69	92.27	103.85	115.43	127.01

PERCENTAGE OF TOTAL ABSOLUTE VALUE RANGE APPLYING TO EACH LEVEL

	10.00	10.00	10.00	10.00	10.00	10.00	10.00	10.00	10.00	10.00
--	-------	-------	-------	-------	-------	-------	-------	-------	-------	-------

FREQUENCY DISTRIBUTION OF DATA POINT VALUES IN EACH LEVEL

LEVEL	1	2	3	4	5	6	7	8	9	10
SYMBOLS
FREQ.	13	10	10	2	2	1	0	0	2	1



Mean Productivity -- 1974

Figure 12

Figure 13.

Mean Chlorophyll a, 1973

ABSOLUTE VALUE RANGE APPLYING TO EACH LEVEL
(* MAXIMUM INCLUDED IN HIGHEST LEVEL ONLY)

MINIMUM	1.17	1.89	2.60	3.31	4.03	4.74	5.45	6.17	6.88	7.59
MAXIMUM	1.89	2.60	3.31	4.03	4.74	5.45	6.17	6.88	7.59	8.30

PERCENTAGE OF TOTAL ABSOLUTE VALUE RANGE APPLYING TO EACH LEVEL

10.00	10.00	10.00	10.00	10.00	10.00	10.00	10.00	10.00	10.00	10.00
-------	-------	-------	-------	-------	-------	-------	-------	-------	-------	-------

FREQUENCY DISTRIBUTION OF DATA POINT VALUES IN EACH LEVEL

LEVEL	1	2	3	4	5	6	7	8	9	10
SYMBOLS
FREQ.	7	9	7	8	4	2	0	1	2	1

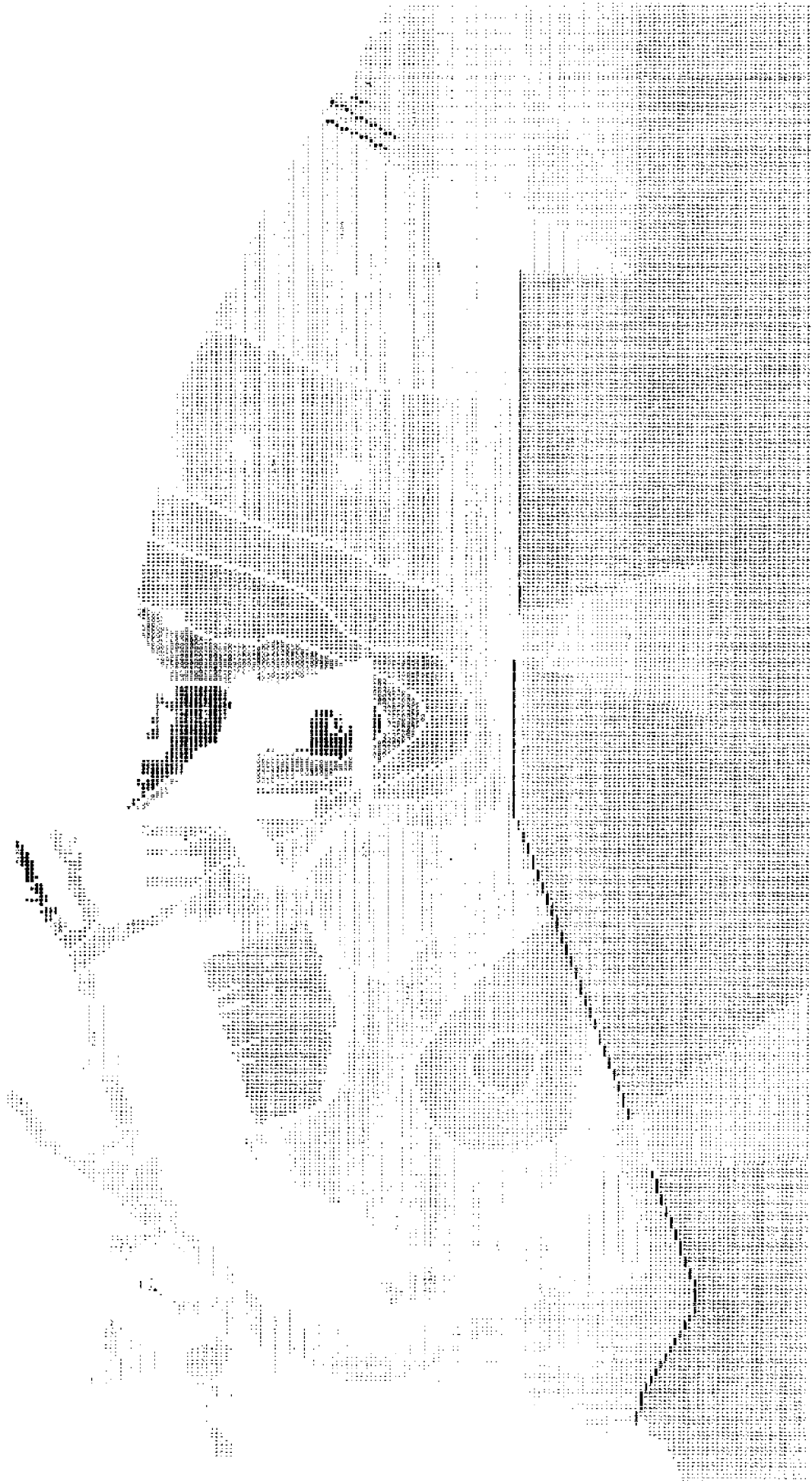

Mean Chlorophyll a — 1973

Figure 13

Figure 14.
Mean Chlorophyll a, 1974.

ABSOLUTE VALUE RANGE APPLYING TO EACH LEVEL
('MAXIMUM' INCLUDED IN HIGHEST LEVEL ONLY)

MINIMUM	1.04	2.33	3.62	4.90	6.19	7.47	8.76	10.04	11.33	12.61
MAXIMUM	2.33	3.62	4.90	6.19	7.47	8.76	10.04	11.33	12.61	13.90

PERCENTAGE OF TOTAL ABSOLUTE VALUE RANGE APPLYING TO EACH LEVEL

	10.00	10.00	10.00	10.00	10.00	10.00	10.00	10.00	10.00	10.00
--	-------	-------	-------	-------	-------	-------	-------	-------	-------	-------

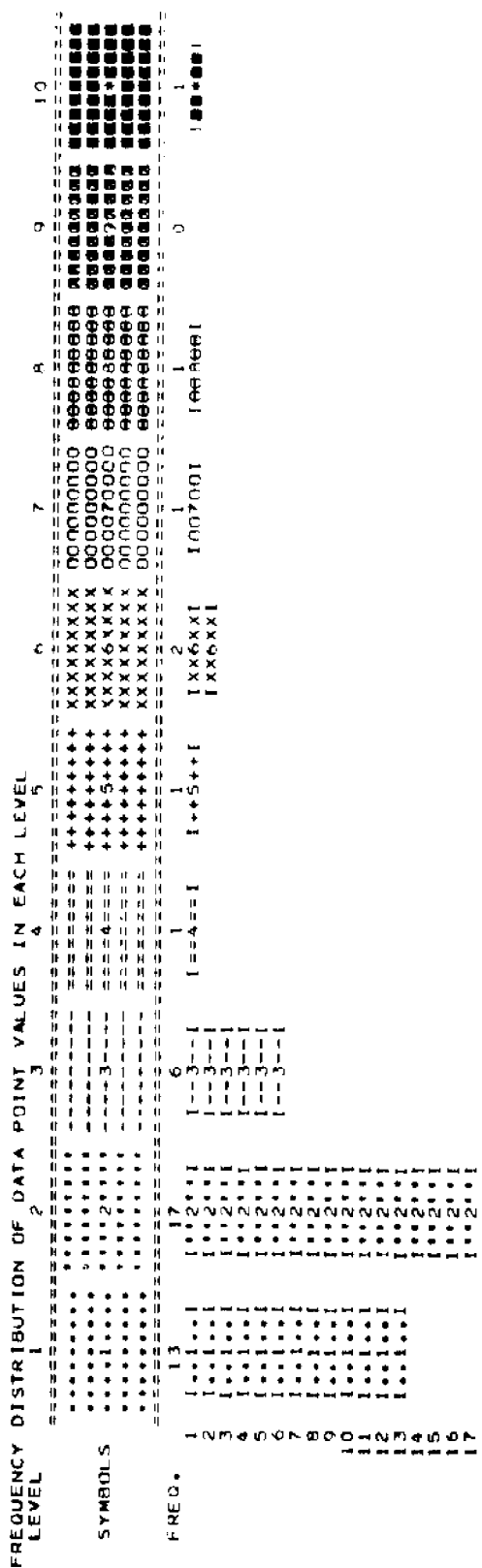



Mean Chlorophyll a — 1974

Figure 14

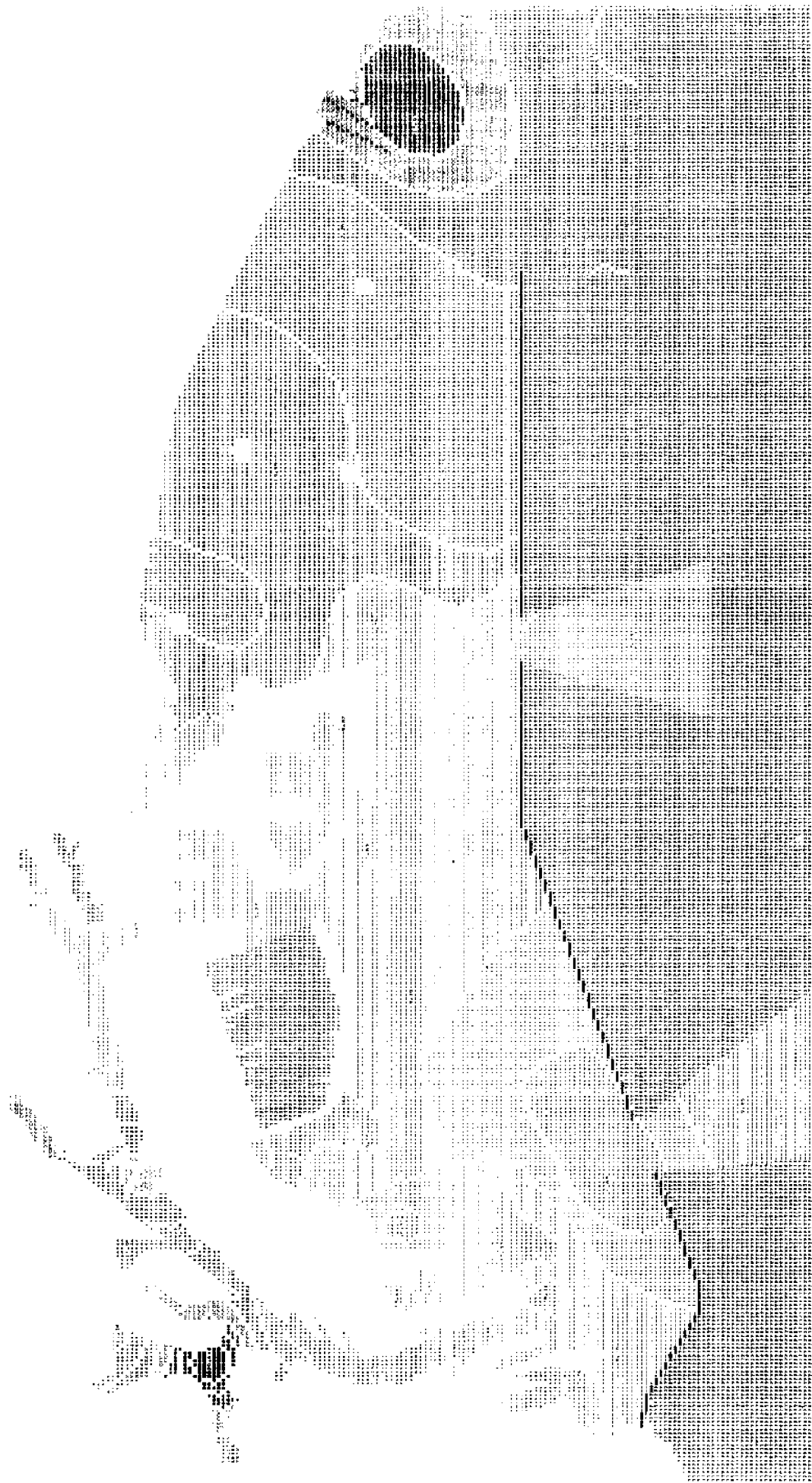

Mean Assimilation Ratio A - 1973

Figure 15



Mean Assimilation Ratio A — 1974

PLATE 16



Figure 17. Mean Plankton Settling Density - 1973

Figure 10.

ABSOLUTE VALUE RANGE APPLYING TO EACH LEVEL
(MAXIMUM INCLUDED IN HIGHEST LEVEL ONLY)

MINIMUM	0.42	0.67	0.92	1.17	1.43	1.68	1.93	2.18	2.44	2.69
MAXIMUM	0.67	0.92	1.17	1.43	1.68	1.93	2.18	2.44	2.69	2.94

PERCENTAGE OF TOTAL ABSOLUTE VALUE RANGE APPLYING TO EACH LEVEL

10.00	10.00	10.00	10.00	10.00	10.00	10.00	10.00	10.00	10.00	10.00
-------	-------	-------	-------	-------	-------	-------	-------	-------	-------	-------

FREQUENCY DISTRIBUTION OF DATA POINT VALUES IN EACH LEVEL

LEVEL	1	2	3	4	5	6	7	8	9	10
SYMBOLS
FREQ.	1	1	1	1	1	1	1	1	1	1

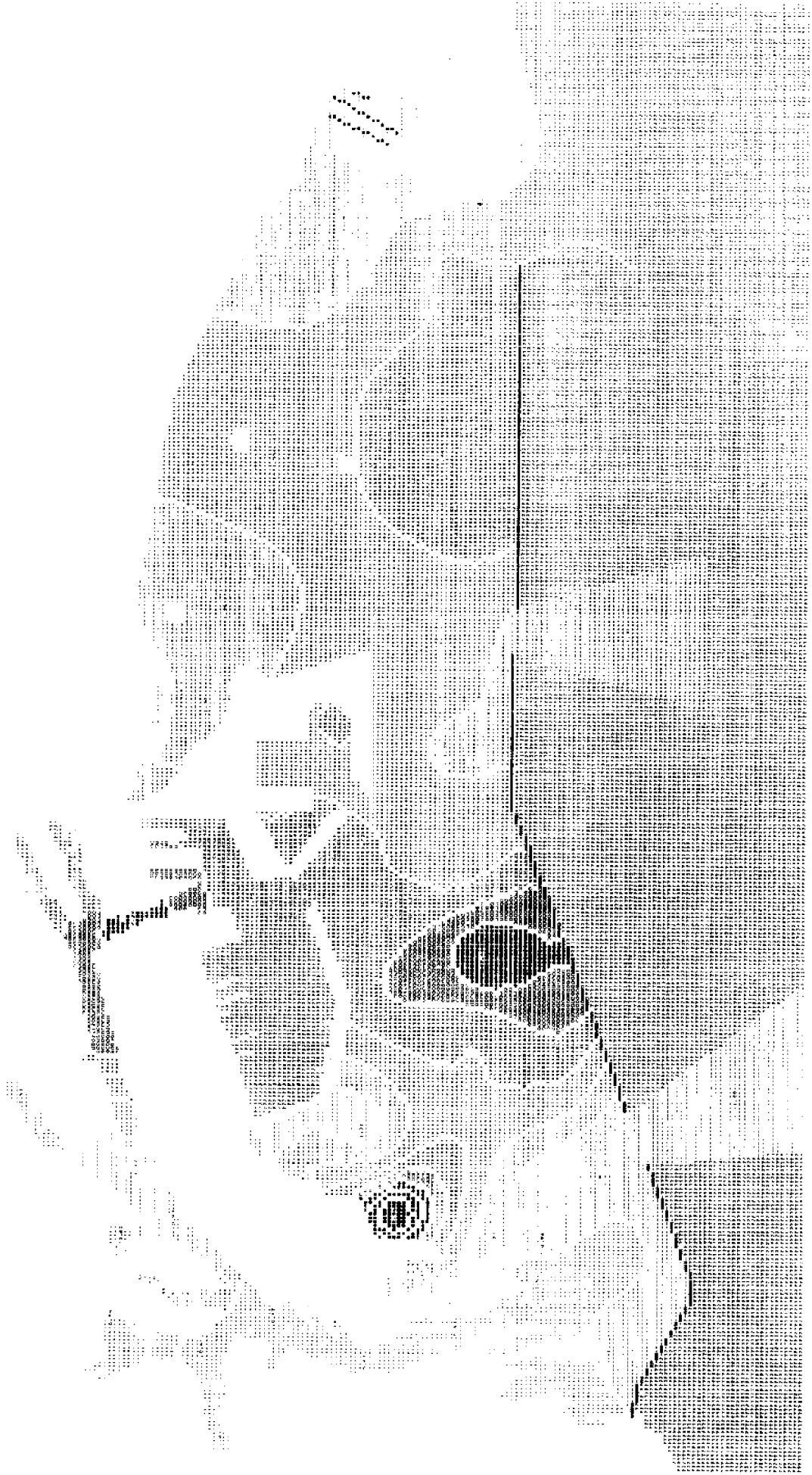

Figure 13. Mean Plankton Settling Density - 1974

Figure 19.

ABSOLUTE VALUE RANGE APPLYING TO EACH LEVEL
(* MAXIMUMS INCLUDED IN HIGHEST LEVEL ONLY)

MINIMUM	0.0	1.13	2.26	3.38	4.51	5.64	6.77	7.90	9.02	10.15	11.28
MAXIMUM	1.13	2.26	3.38	4.51	5.64	6.77	7.90	9.02	10.15	11.28	

PERCENTAGE OF TOTAL ABSOLUTE VALUE RANGE APPLYING TO EACH LEVEL

	10.00	10.00	10.00	10.00	10.00	10.00	10.00	10.00	10.00	10.00	10.00
--	-------	-------	-------	-------	-------	-------	-------	-------	-------	-------	-------

FREQUENCY DISTRIBUTION OF DATA POINT VALUES IN EACH LEVEL

LEVEL	1	2	3	4	5	6	7	8	9	10
Symbols
FREQ.	1	1	1	1	1	1	1	1	1	1



Figure 19. **Podon polyphemoides** - 1974



Figure 20. *Acartia tonsa*



Figure 21. *Oithona oculata* - 1974

Fish

More than 130 species of fish have been reported from Los Angeles-Long Beach Harbors (Chamberlain, 1973; Stephens, et al., 1974; AHF, 1975) collected by trawl, gill net and hook and line (Figure 22). Stephens, et al. (1974), in analyzing these data, reported that the harbor supports a richer fish fauna than offshore areas of similar depth. The most numerous fish in the harbor were the white croaker and the northern anchovy, which made up 69% of the catch. Both of these fish are plankton feeders and their large numbers probably are related to the enrichment of the harbor biota by the effluents supplied.

Distribution in the harbor was described by Stephens, et al. (1974). Three general populations of fish were recognized, based on otter trawl collections as shown in Figure 23. These are croakers, distributed throughout the outer harbor except where the flat fish are found closest to the breakwater in the western areas of the outer harbor and where rockfish abound near the breakwater in the outer Long Beach Harbor. The croaker population appears to be the most widespread and the most tolerant of the effluents discharged in the harbor.

The anchovy populations in and near the harbor have been studied by Brewer (1975). In the harbor the population consists primarily of the first year age class. Since egg abundance is richest outside the harbor (Figure 24), it suggests that the juveniles migrate inshore, perhaps attracted by the shelter and nutrients offered by these waters. The northern anchovy caught

as bait is the only commercial fishery permitted inside the harbor. It is surmised that older anchovies leave the harbor and are recruited to the offshore fishery in existence there. The harbor serves as a nursery for this population.

Preliminary results of the present studies of the harbor ichthyofauna indicate that there is a series of zones around the outfalls. These zones, shown in Figure 25, were initially found during bioassay tests of the cannery wastes using anchovy eggs and larvae as test organisms. The eggs and larvae are among the organisms most sensitive to environmental stress. Closest to the outfalls is a zone called the mortality zone, in which none of the eggs and larvae survived under test conditions. The zone of inhibition is the zone in which exposure of eggs and larvae to the waters resulted in as much as 50% survival. In the zone of low productivity survival noted was as high as 100%. Beyond that no mortality was found under test conditions. Other data, some of which are discussed above and elsewhere in these reports, suggest that bioenhancement occurs beyond this zone.

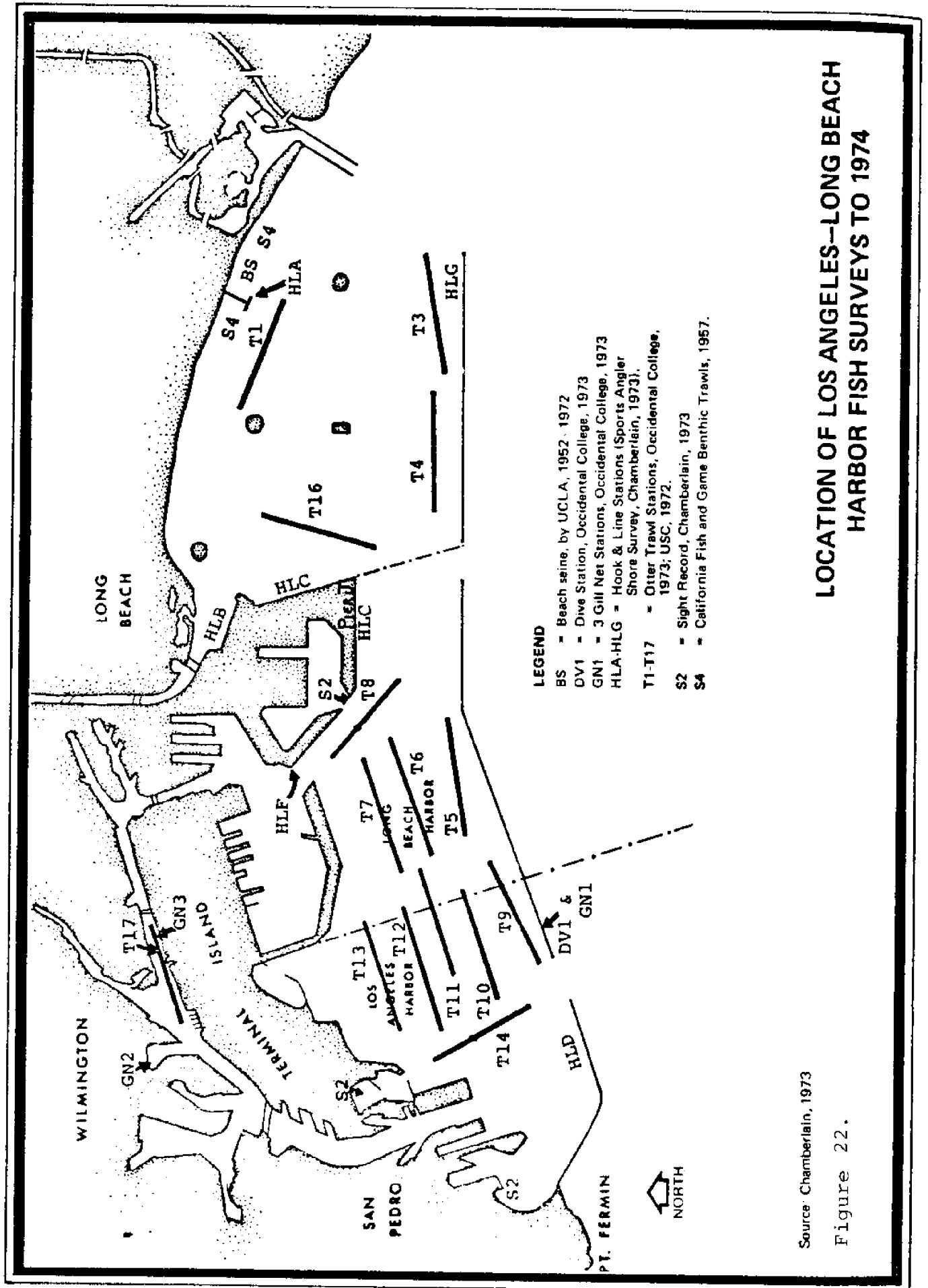

**LOCATION OF LOS ANGELES—LONG BEACH
HARBOR FISH SURVEYS TO 1974**

Source: Chamberlain, 1973

Figure 22.

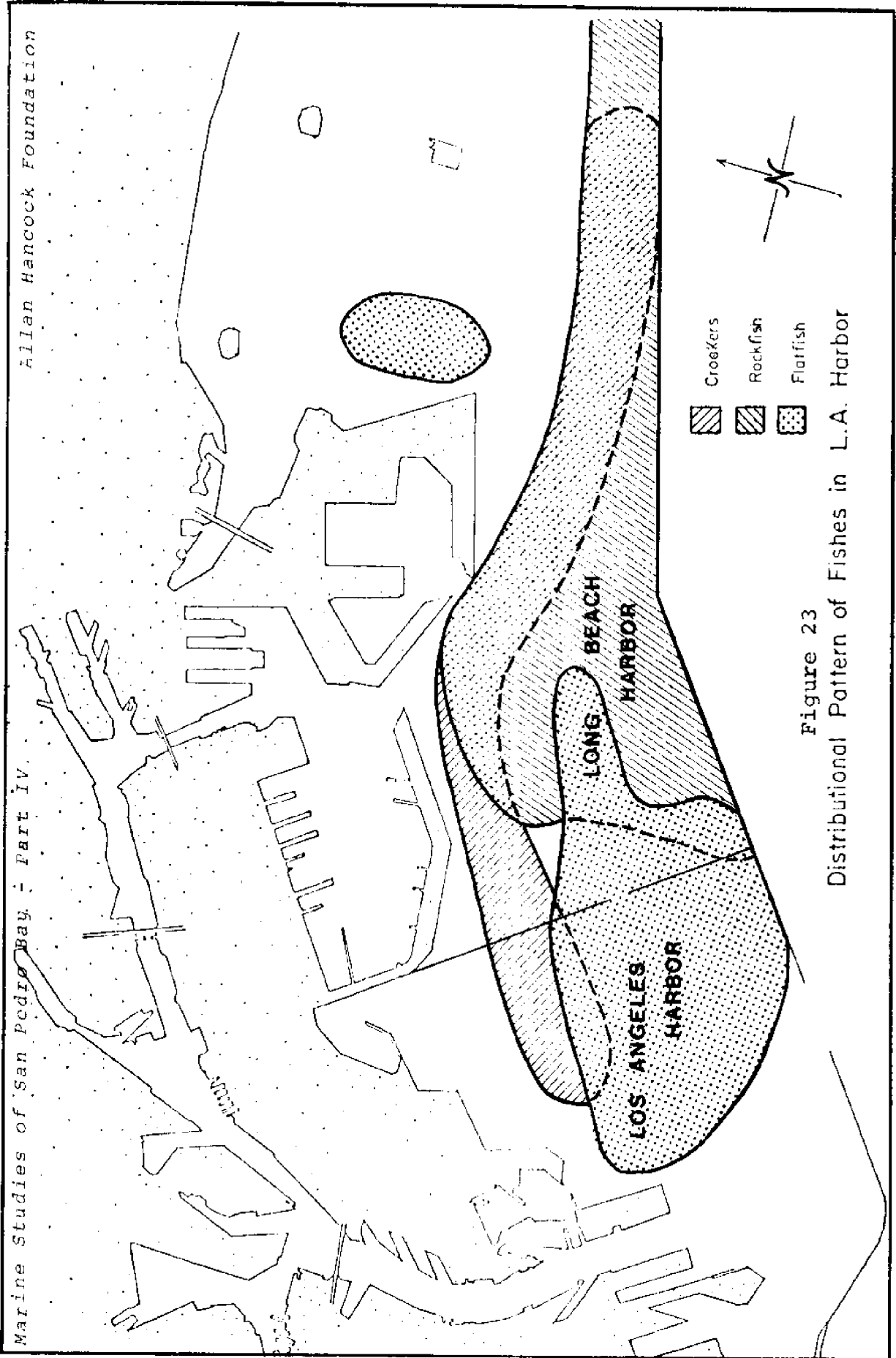

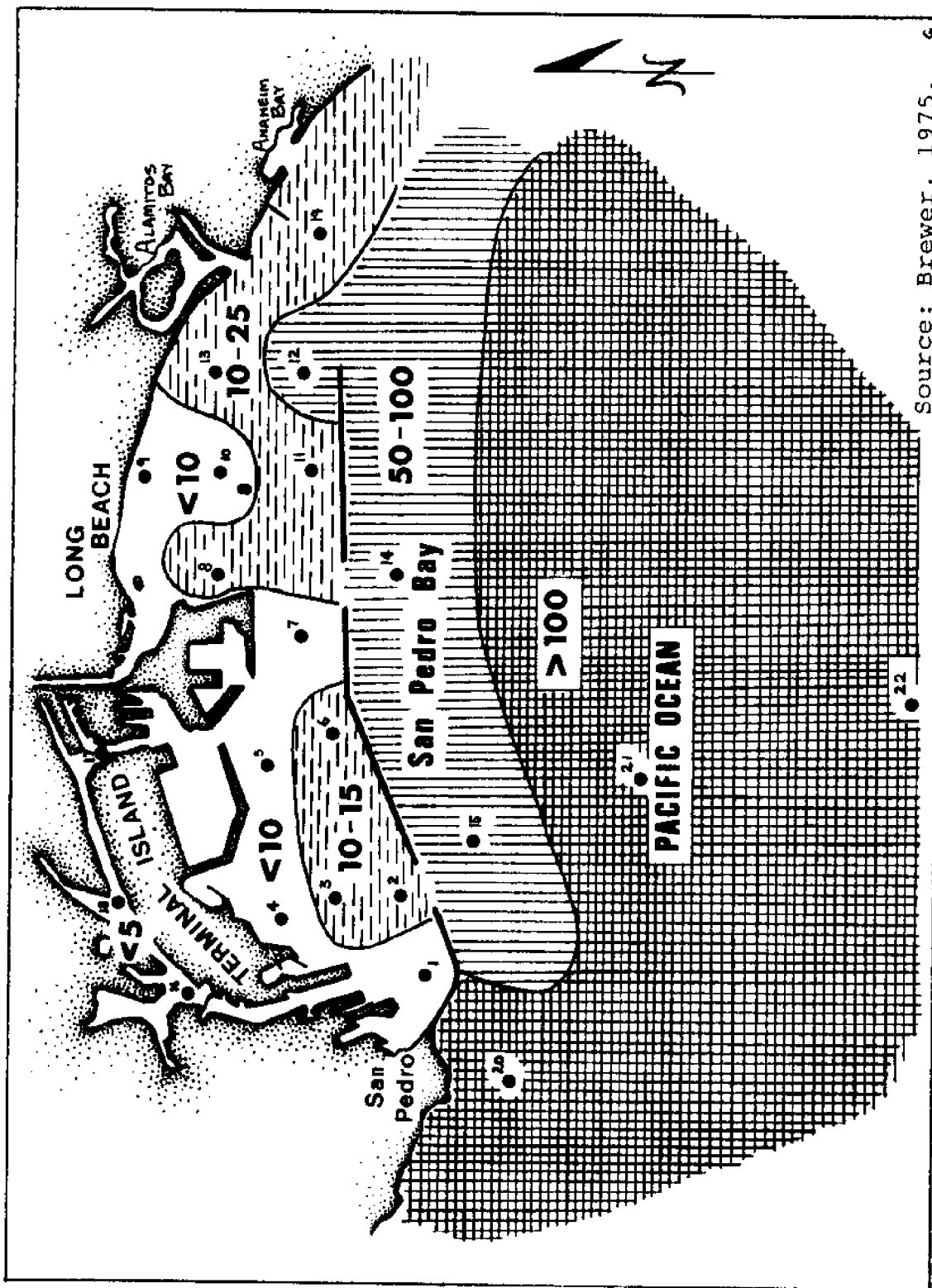
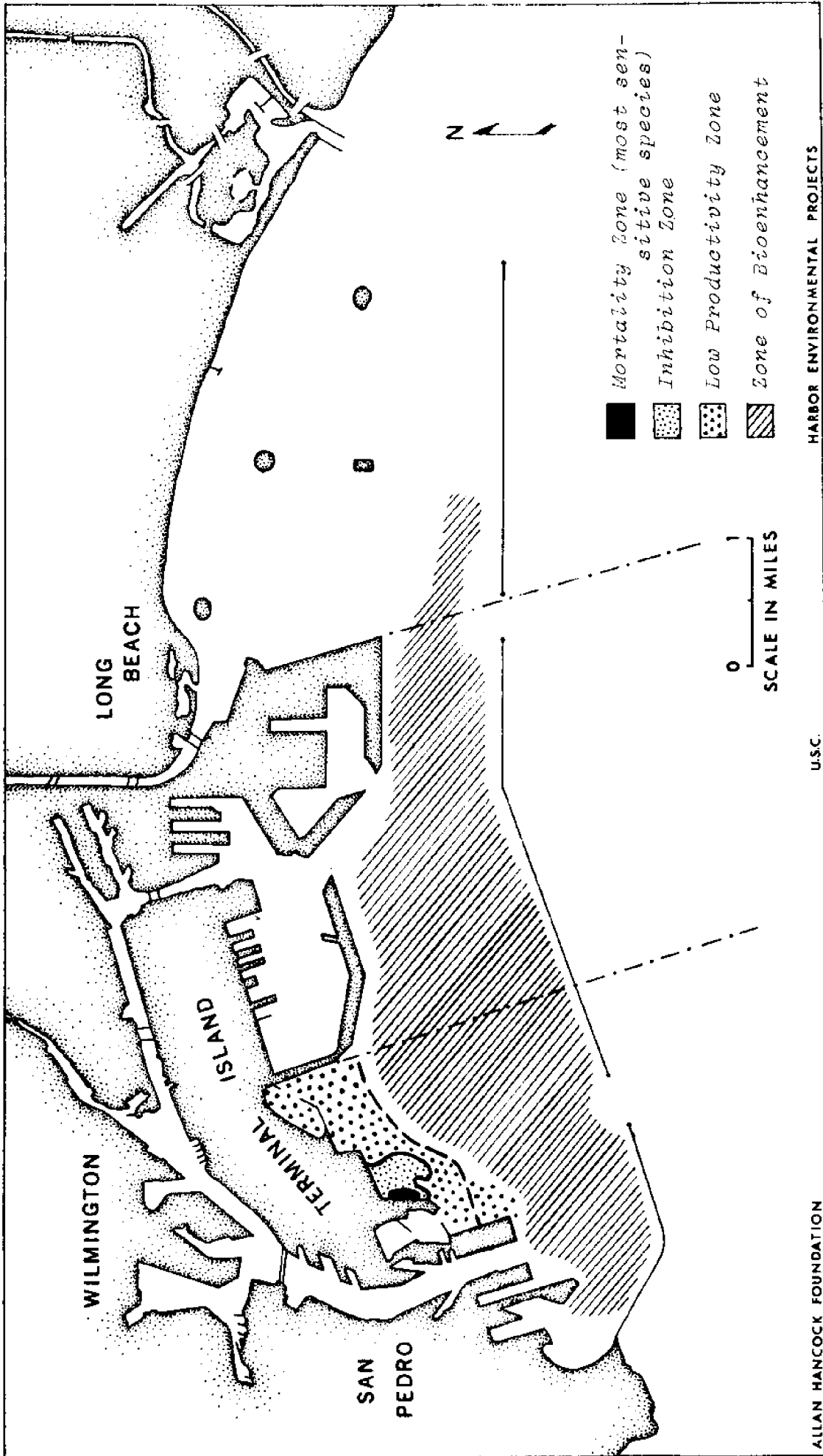

Figure 24. Map of the Los Angeles-Long Beach Harbor and San Pedro Bay, indicating the mean number of anchovy eggs per standardized trawl over a 20 month period.



HARBOR ENVIRONMENTAL PROJECTS

U.S.C.

ALLAN HANCOCK FOUNDATION

Figure 25. Zones of Bioenhancement, Outer Los Angeles-Long Beach Harbors.

LITERATURE CITED

- Allan Hancock Foundation. 1975. Environmental investigations and analyses for Los Angeles-Long Beach Harbors. A report to the U.S. Army Corps of Engineers, Contract No. DAWCD 9-73-0112, 552 pp. (Revised 1976).
- Bascom, W. 1974. The disposal of waste in the ocean. *Scientific American*, vol. 231, no. 2. p. 16-25.
- _____. 1976. Waste solids entering the ocean in the Los Angeles area. Conference on Sludge Disposal Alternatives in the Ocean off Southern California. Calif. Instit. Technol., 8 Sept. 1976.
- Chen, K.Y., and J.C.S. Lu. 1974. Sediment compositions in Los Angeles-Long Beach Harbors and San Pedro Basin. *Marine Studies of San Pedro Bay, California, Part 7*. Allan Hancock Foundation and Sea Grant Program, University of Southern California. 1-177.
- Emerson, R.R. 1974. Preliminary investigations of the effects of resuspended sediment on two species of benthic polychaetes from Los Angeles Harbor. In *Marine Studies of San Pedro Bay, California, Part 3*. Allan Hancock Foundation and Sea Grant Program, University of Southern California. 97-110.
- McAnally, W.H. 1975. Los Angeles and Long Beach Harbors model study. Report 5. Tidal verification and base circulation tests. U.S. Army Corps of Engineer Waterways Experiment Station, Vicksburg, Miss.
- Robinson, K., and H. Porath. 1974. Current measurements in the outer Los Angeles Harbor. *Marine Studies of San Pedro Bay, California, Part 6*. Allan Hancock Foundation and Sea Grant Program, University of Southern California. 1-91.
- Soule, D.F., and M. Oguri. 1972. Circulation patterns in Los Angeles-Long Beach Harbor. Drogue study atlas and data report. *Marine Studies of San Pedro Bay, California, Part 1*. Allan Hancock Foundation and Sea Grant Program, University of Southern California.

PART A.

QUANTIFICATION OF THE ASSEMLATIVE CAPACITY OF
L.A. HARBOR: A DYNAMIC OXYGEN MODEL

by

John Stanley-Miller
Assistant Professor
Environmental Engineering

Patricia Kremer
Research Associate
Harbors Environmental Projects

and

Wen-Li Chiang
Research Assistant
Environmental Engineering

INTRODUCTION

DESCRIPTION OF THE PROBLEM

The "assimilative capacity" of a harbor relates to the quantity of wastes that can be "safely" dumped into the harbor without overloading the system and causing significant harm to aquatic organisms. Excessive dumping of fish cannery and municipal wastes into Los Angeles Harbor could surpass the harbor's assimilative capacity, resulting in significant environmental degradation. Appropriate waste disposal management in L.A. Harbor requires improved understanding and quantification of the harbor's oxygen assimilative capacity. Oxygen is an important constituent to consider since anoxic conditions may damage commercial and sport fishing and create unaesthetic odors and water color.

APPLICATION OF DYNAMIC MODELLING

The oxygen assimilative capacity of Los Angeles Harbor is a function of physical, biological, and chemical processes including photosynthesis, aeration, oxidation, and sedimentation. The system is complex and obtaining precise data for various important rates is difficult. Computer simulation is a promising method for studying such a complex system, and attempting to define quantitatively the critical parameters which control the level of oxygen present.

During computer simulation, mathematical equations are used to represent the actual processes occurring in the harbor waters. Appropriate existing data is incorporated to

improve the reliability of results, and sensitivity analysis and other tests can indicate which missing data are most crucial for obtaining better results from the model. Collection of the missing data coupled with further computer simulation should then result in improved understanding and quantification of the oxygen assimilative capacity of L.A. Harbor.

SCOPE OF THE PAPER

A computer model consists of a set of assumptions about how reality works. Before believing the results of a computer model, one should carefully evaluate the assumptions underlying the model. To facilitate review of our study, the following section of Model Assumptions details the important assumptions incorporated into the current model. The section on use of the model then goes on to present application of the model for parameter sensitivity and policy analysis. The section on improving the model explains possible extensions of the current model, while the last section provides preliminary conclusions based on work to date.

MODEL ASSUMPTIONS

THE HARBOR SYSTEM

The first step in building a computer model is to identify the system under study by indicating the system boundary, time horizon, and degree of spatial aggregation.

The System Boundary

Figure A1 depicts the L.A. Harbor indicating the loca-

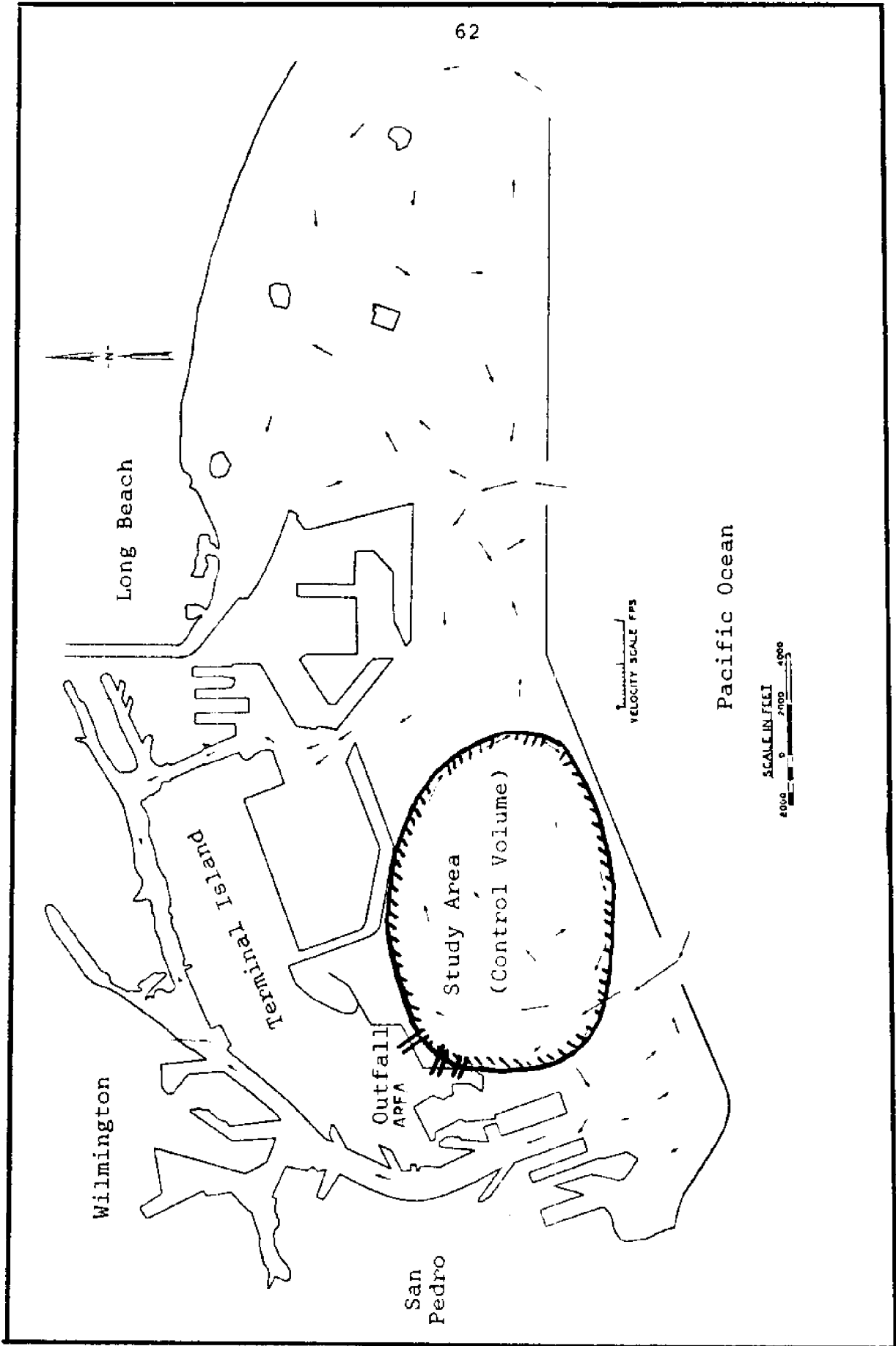

FIGURE A1 Location of Study Area in Los Angeles Harbor

tion of waste disposal sites from the canneries and indicating the location of the proposed boundary for the model, hereafter referred to as HAC2 (for Harbor Assimilative Capacity II). The boundary shown in Figure A1 was chosen because preliminary data on current patterns indicate that the water in that area rotates as a gyre, has little mixing with surrounding waters and is fairly uniform in its characteristics such as temperature and dissolved oxygen, with the exception of the waters immediately around the outfalls. We refer to the shaded area in Figure A1 as the "control volume" for our study.

Time Horizon

HAC2 focuses on a time frame of one year to allow inclusion of seasonal effects. The average temperature of L.A. Harbor waters varies between approximately 12° C in the winter to 20° C in the summer. This temperature variation leads to significant seasonal changes in aeration, oxydation, and especially algae growth.

Spatial Aggregation

Computer simulation models always simplify reality in order to understand fundamental relationships. Typically, a model will either emphasize spatial or dynamic aspects. We decided to emphasize non-linear and dynamic aspects of the harbor system. Spatial disaggregation was kept to a minimum. HAC2 portrays average values for all variables, ignoring any gradients in either the horizontal or vertical directions. The averaging process places an important qualification on

model results. When HAC2 generates a dissolved oxygen value of, for example, 6 mg/l, in the real system the dissolved oxygen could be 10 mg/l at the surface and 1 or 2 mg/l at the bottom, with an average value of approximately 6 mg/l. As long as one is aware of the model's limitations, the information provided is useful and can give a measure of "average" conditions, even though extreme values are overlooked. Inclusion of extreme conditions into the modified models is an area for future work.

MODEL STRUCTURE

The goal of this dynamic oxygen model is to predict seasonal average values for the amount of dissolved oxygen in water. Figure A2 shows dissolved oxygen and five rates that govern how dissolved oxygen changes over time: 1) aeration; 2) photosynthesis; 3) oxygen demand; 4) benthic oxygen uptake, and 5) oxygen migration. Calculation of the rates of photosynthesis and oxygen demand requires predictions about algal growth and BOD, respectively. Figure A3 shows the complete structure of HAC2 with additional boxes for Algae (mg/liter chlorophyll) and BOD (mg/liter oxygen) and the rates that control algae and BOD. In HAC2 each of the rates (valve symbols ) changes over time affecting the amount of dissolved oxygen in the model according to the following differential equation:

$$\frac{d(DO)}{dt} = AER + PHOTO - OD - BOU + OM$$

Figure A2 illustrates this balance.

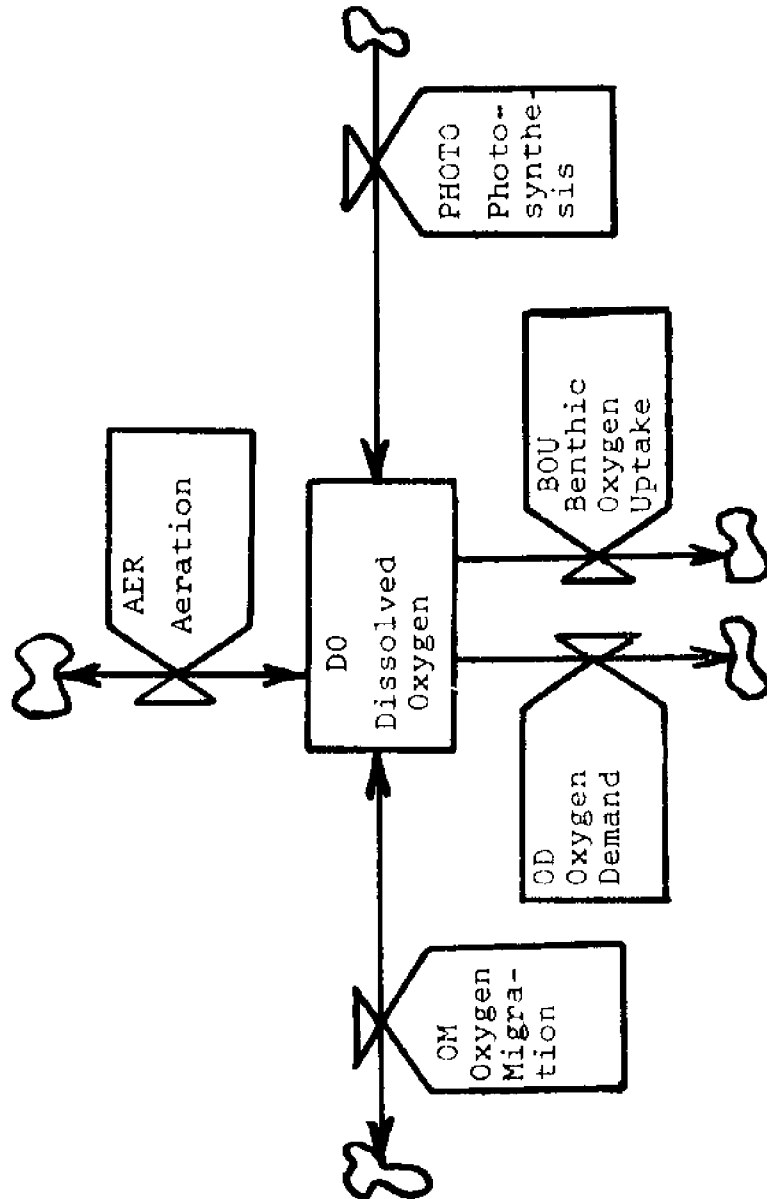

FIGURE A2 Factors Affecting Dissolved Oxygen

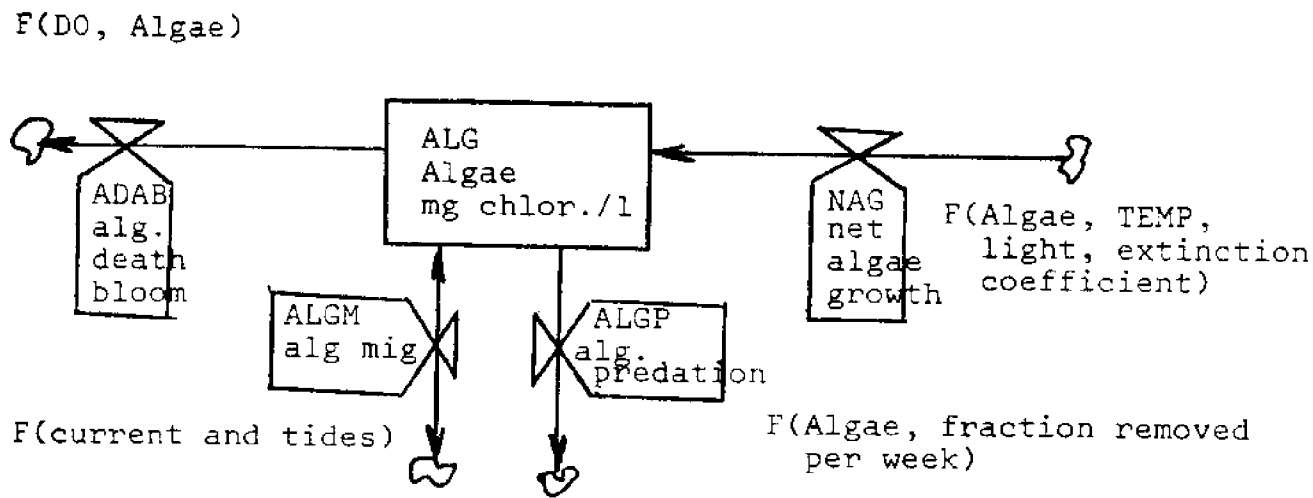
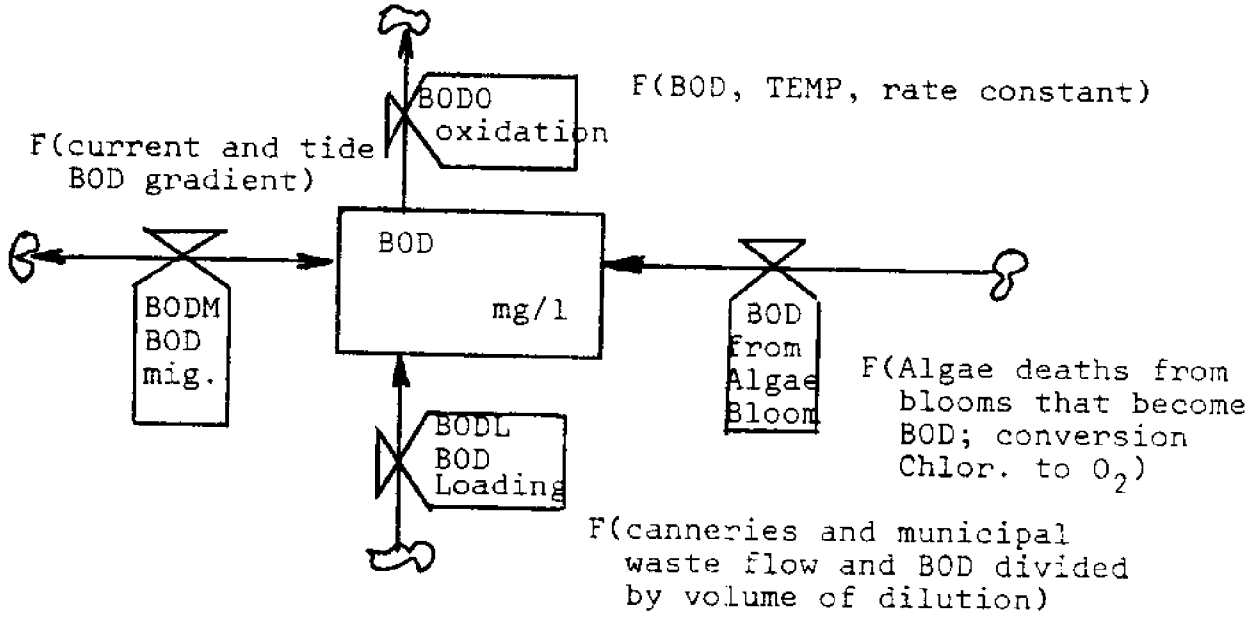
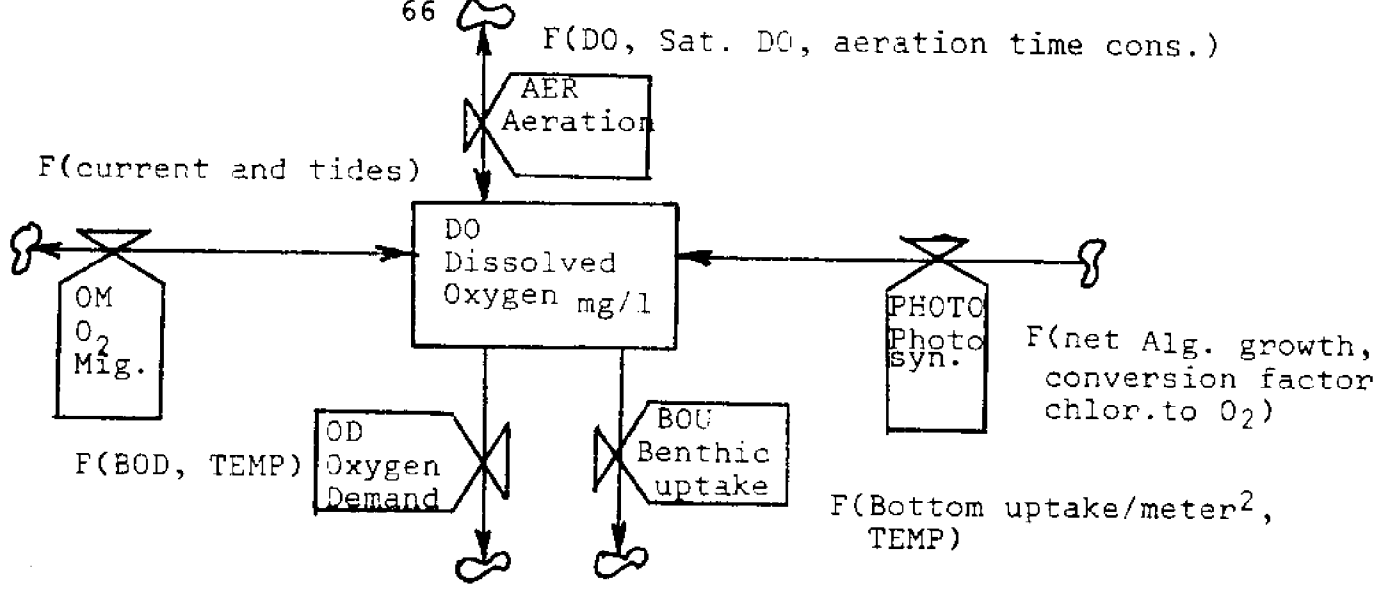

FIGURE A3 Structure of HAC2: Note for simplicity connections between symbols are not shown

The following sections describe the more important equations in HAC2. A complete list of model equations appears in the Appendix to this report. HAC2 employs a computer simulation language called DYNAMO (Pugh, 1970).

Aeration

Aeration accounts for oxygen passing in or out of the water across the air-sea interface. We assume aeration is proportional to the difference between the actual amount of dissolved oxygen in the control volume and the saturation level for a given water temperature.

$$\text{AER} = (\text{OSL} - \text{DO}) (\text{AERK})$$

AER = aeration (mg/l/wk)

OSL = oxygen saturation level (mg/l)

DO = dissolved oxygen (mg/l)

AERK = aeration constant (fraction/wk)

The oxygen saturation level OSL is a function of salinity and temperature. At high temperatures OSL is less than at low temperatures for the same water salinity. The relationship between OSL and water temperature TEMP is well established. We used data from Fair et al. (1968) in HAC2.

The aeration constant AERK, represents what fraction of the difference between saturation and actual DO is made up each week. In HAC2, the aeration constant is a function of temperature and surface area-to-depth ratio according to the following equation:

$$\text{AERK} = \text{AERK20} * 0.25 * e^{0.0692 * \text{TEMP}} (\text{SADM})$$

AERK = aeration constant (fraction/wk)
 AERK20 = aeration constant @ 20^o C (fraction/wk)
 0.25 = conversion of AERK20 to aeration constant at 0^o C
 (dimensionless)
 0.0692 = time constant relating temperature change to
 change in AERK (1/^oC)
 TEMP = water temperature (^oC)
 SADM = surface area to depth multiplier (dimensionless)

The AERK20 is difficult to measure in the field and is a function of wind velocity, waves, mixing of water, etc. HAC2 uses a value of 2 for AERK20, derived from the literature (Fair, et al., 1968). Most measured aeration constants are for streams and rivers, which would differ from conditions in L.A. Harbor. Some form of field measurement of the aeration constant at 20^o C would be useful.

Photosynthesis

Oxygen is produced by algal photosynthesis. As such, the units of algal growth and biomass (chlorophyll) may be converted to oxygen equivalents. Using an average carbon-to-chlorophyll ratio of 50:1 for phytoplankton (Parsons et al, 1961) and knowing that the fixation of one atom carbon (a.w. 12) releases 2 atoms oxygen (a.w. 16), an increase in algal biomass of 1 mg chlorophyll results in a release of approximately 130 mg of oxygen.

$$\text{PHOTO} = \text{NAG} * \text{OEC}$$

$$\text{OEC} = 130$$

PHOTO = photosynthesis (mg O₂/l/wk)

NAG = net algal growth (mg chlorophyll/l/wk)

OEC = oxygen equivalent of chlorophyll (mg O₂/mg chlorophyll)

Net Algal Growth

It was assumed that net algal growth was controlled primarily by the ambient water temperature and the available light. Because the major nutrients seem to be always abundant in the harbor, their effect was not included in the model. The following equations quantify this exact effect of light and temperature on phytoplankton growth and represent the condensation of a review of the pertinent literature (Eppley, 1972; Chen, 1970; DiToro et al., 1971; Riley, 1963).

$$G = GMAX * 0.85 * \frac{e * f}{K * Z} \left(e^{\frac{\bar{I}}{IOPT}} * e^{-KZ} - e^{-\frac{\bar{I}}{IOPT}} \right)$$

$$NAG = LAG * G$$

$$GMAX = 4.1 * e^{0.0633 * TEMP}$$

$$\bar{I}/IOPT = 2$$

NAG = net algal growth (mg chlorophyll/l/wk)

ALG = algae (mg chlorophyll/l)

G = growth factor (fraction/wk)

GMAX = maximum algal growth wotj zero self-shading
(fraction/wk)

0.85 = correction for daily variation in light intensity
(dimensionless)

e = base of natural log (dimensionless)

f = photo period (= .5) (dimensionless)

K = light extinction coefficient (1/meters)

Z = depth of water (meters)

\bar{I} = average light intensity (g cal/cm²/day)

IOPT = optimal light intensity for algal growth
(g cal/cm²/day)

Oxygen Demand

Oxygen demand accounts for oxygen consumed for degradation of biodegradable material (BOD). BOD oxidation equals oxygen demand and is equal to the amount of BOD times the BOD time constant associated with harbor waters. Experimental studies indicate a value of .4/day at 20°C for L.A. Harbor waters.

$$OD = BOD * BODK$$

OD = oxygen demand (mg/l/week)

BOD = BOD (mg/l)

BODK = BOD constant (fraction/wk)

Benthic Oxygen Uptake

Benthic organisms and chemical oxidation of sediments on the harbor bottom utilize a significant amount of dissolved oxygen. We assume that the benthic oxygen uptake is approximately 33.6 grams oxygen/meter² wk at 20° C. This value is slightly larger than many of those reported for intact coastal sediments (Pamatmat, 1968; Hargrove, 1969; Nixon et al., in press) and is meant to include the oxygen demand of resuspended sediments as well. This demand was calculated using results of investigations in L.A. Harbor (AHF, 1975) and assuming 5% of the bottom sediment in the study area is resuspended every day. The expression of the benthic oxygen uptake used in the model also includes the trend for benthic oxygen uptake to increase exponentially with temperature. Direct field measurements of the benthic oxygen uptake are planned for the harbor, to refine this preliminary estimate.

$$\text{BOU} = (\text{BOU20} * 0.25 * e^{0.0692 * \text{TEMP}}) / \text{DEPTH}$$

$$\text{BOU20} = 33.6$$

$$\text{DEPTH} = 10$$

BOU = benthic oxygen uptake (mg/l/wk)

BOU20 = benthic oxygen uptake @ 20°C (grams/meter² wk)

0.25 = conversion of BOU20 to a value at 0°C (dimensionless)

0.0692 = time constant for change in BOU as a function of temperature (1/°C)

TEMP = temperature

DEPTH = average water depth (meters)

Oxygen Migration

Oxygen migration represents the amount of oxygen moving into or out of the control volume because of tidal and current flows. In the model, it is assumed that the oxygen level in the surrounding waters is saturated, so that it equals the oxygen saturation level OSL. The amount of oxygen migration is then equal to the difference between the oxygen in the surrounding waters and the oxygen level in the control volume times the fraction of new water added weekly due to currents and tides. The value currently used for this exchange rate is 0.5 of the volume per week.

$$\text{OM} = (\text{OSL} - \text{DO}) * \text{FNW}$$

$$\text{FNW} = 0.5$$

OM = oxygen migration (mg/l/wk)

OSL = oxygen saturation level (mg O₂/l)

DO = dissolved oxygen (mg O₂/l)

FNW = fraction of new water (fraction/wk)

USING THE MODEL

REQUIRED INPUTS

In order to simulate the behavior of the L.A. Harbor using HAC2, we have to select parameters for initial conditions, exogenous inputs, model constants, and time invariant model relationships. One important exogenous function required to operate HAC2, for example, is the average water temperature in L.A. Harbor. Time series data has been collected on average water temperature and was used in HAC2. (see Figure A4).

A second exogenous input is the amount of waste material dumped into the harbor. Data collected by the canneries and the City of Los Angeles indicate that, on the average, 2.5×10^8 grams BOD/week are dumped into the control volume depicted in Figure A1. Of course, the actual loading fluctuates around this average, depending on the season of the year. Future model work will invariably entail estimation of a fluctuating BOD loading that more closely represents actual conditions.

TYPICAL OUTPUT

Figure A5 depicts typical computer-generated output from HAC2. The computer can either print out numerical, tabular results, or the computer can plot graphical results, as in Figure A5.

Figure A5 shows a typical output from a simulation run. Several important variables are plotted on the vertical axis against time (in weeks) on the horizontal axis. Explanations of the variables are given in the following table.

Harbors Environmental Projects University of Southern California

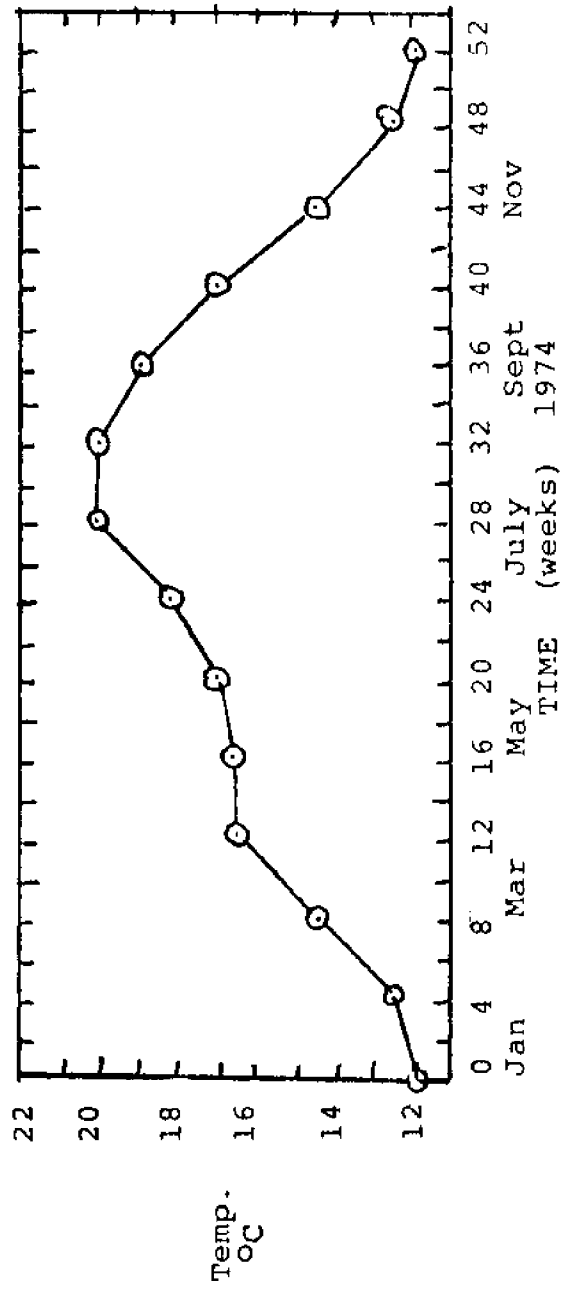

Figure A4 Temperature Versus Time in LA Harbor

STD.

5/06/76

(Revised 5-6-76)

HARBOR ASSIMILATIVE CAPACITY 2

DO=O, OSL=S, ALG=A, AER=R, PHOTO=P, OM=M, OD=D, BOU=U, TEMP=T

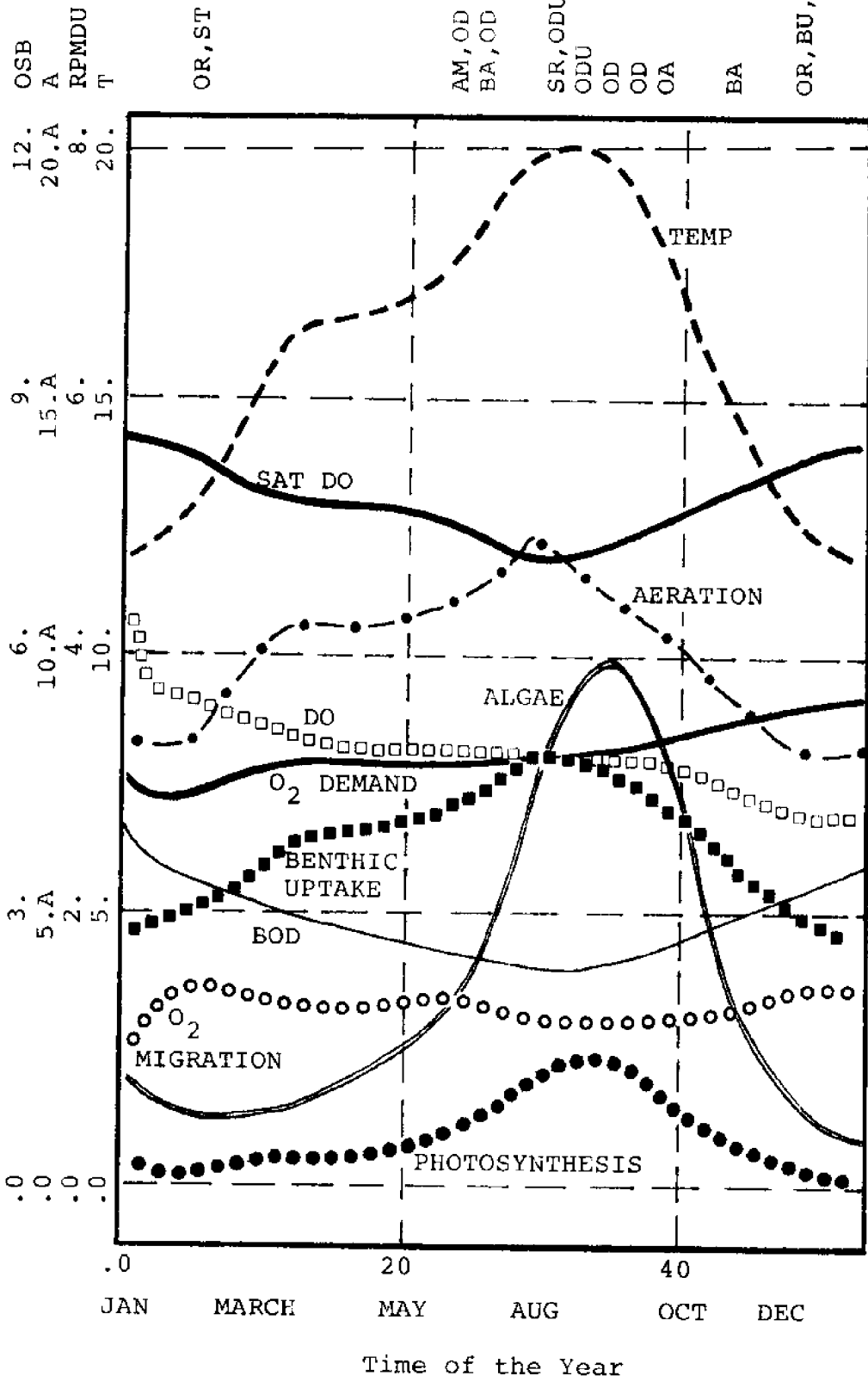

FIGURE A5. Standard Run of HAC2.

tions of the symbols used in the plot are given to the left of the vertical axis. The magnitude of each variable at a given point in time can be read from the vertical axis using the correct scale, which is the one where the plot symbol for the variable occurs at the top of the scale (in the scales A means 10^{-3}). All computer runs use the same vertical scales to facilitate comparison between runs. The three lines in the upper left corner indicate parameters which have been changed from the values occurring in the standard model as given in the appendix.

The computer prints only the individual characters (for example, the string of 0's indicating dissolved oxygen DO) in the plots. To improve the readability of the graphs, the curves were drawn manually connecting the individual, identical symbols.

In Figure A5 dissolved oxygen DO starts initially in January with a value of 6.7 mg/l. DO drops to a minimum value of approximately 4.8 mg/l in late July and then rises again to 5.8 mg/l in December. The decrease in average DO is primarily a consequence of water temperature which peaks in August. A higher water temperature increases benthic uptake of oxygen and oxygen demand from BOD. Interestingly, when the water has its lowest DO in summer, the BOD is also lowest. DO and BOD track each other (assuming a constant inflow of BOD loading) since a high rate of BOD degradation tends to lower both BOD (which is being oxidized) and dissolved oxygen (which

is required for oxidation). The amount of algae, on the other hand, grows inversely to DO and BOD. Algal growth is stimulated by higher temperature, so that algae peaks in quantity around August (which corresponds roughly to collected field data). As water temperature falls from July to December, so does the amount of algae. The peak in algae and photosynthetic activity in August corresponds to a high average value of algae in the harbor and does not attempt to predict or represent the periodic "algal blooms" that occur in the spring and early fall. The dynamics of algal blooms are poorly understood and the time horizon of blooms is very short (in the order of days). Explicit representation of algal blooms required a different model with a time frame considerably shorter than the one year time horizon of HAC2.

In Figure A5 the rates influencing dissolved oxygen are plotted on the same scale to facilitate visual comparison of degree of their importance. Aeration is largest in magnitude, followed by oxygen demand from BOD, benthic oxygen uptake, oxygen migration, and photosynthesis. The relative importance of these rates could change with new values for model parameters. Model parameters can be evaluated through parameter sensitivity tests, as explained in the following section.

SENSITIVITY ANALYSIS

The ability to perform sensitivity analysis is an important attribute of a computer simulation model. Sensitivity analysis involves identifying those parameters in the model

which are most important in determining behavior. Some parameters can be changed over a wide range without significantly influencing model output. Small changes in other parameters can markedly affect results. Identification of sensitive parameters is important, since measurement and collection of data is expensive. Rather than trying to collect data on everything, sensitivity analysis can indicate which data are most significant.

Figure A6 depicts output from an example sensitivity analysis from HAC2. In this analysis the light extinction coefficient, which reflects the "clearness" of water and hence the ability for light to penetrate and increase algal growth, was decreased by 30%, from a value of 1.75 per meter to a value of 1.5 per meter. A decrease in the light extinction coefficient corresponds to an increase in the clearness of the harbor waters with more light made available for photosynthesis.

Analysis of Figure A6 shows that decreasing the light extinction coefficient has a marked impact on photosynthesis and amount of algae; but little effect on dissolved oxygen when compared to the Standard Run of Figure A5. Algae and photosynthesis peak in August as they did in the Standard Run; however, they peak at a value approximately 100% higher. Dissolved oxygen DO increases by only about 7% as a consequence of the photosynthetic activity. There are two reasons why dissolved oxygen doesn't change very much even though

HARBOR ASSIMILATIVE CAPACITY 2 (Revised 5-6-76) 5/06/76 Lower K

DO=O, OSL=S, BOD=B, ALC=A, AER=R, PHOTO=P, OM=M, OD=D, BOU=U, TEMP=T

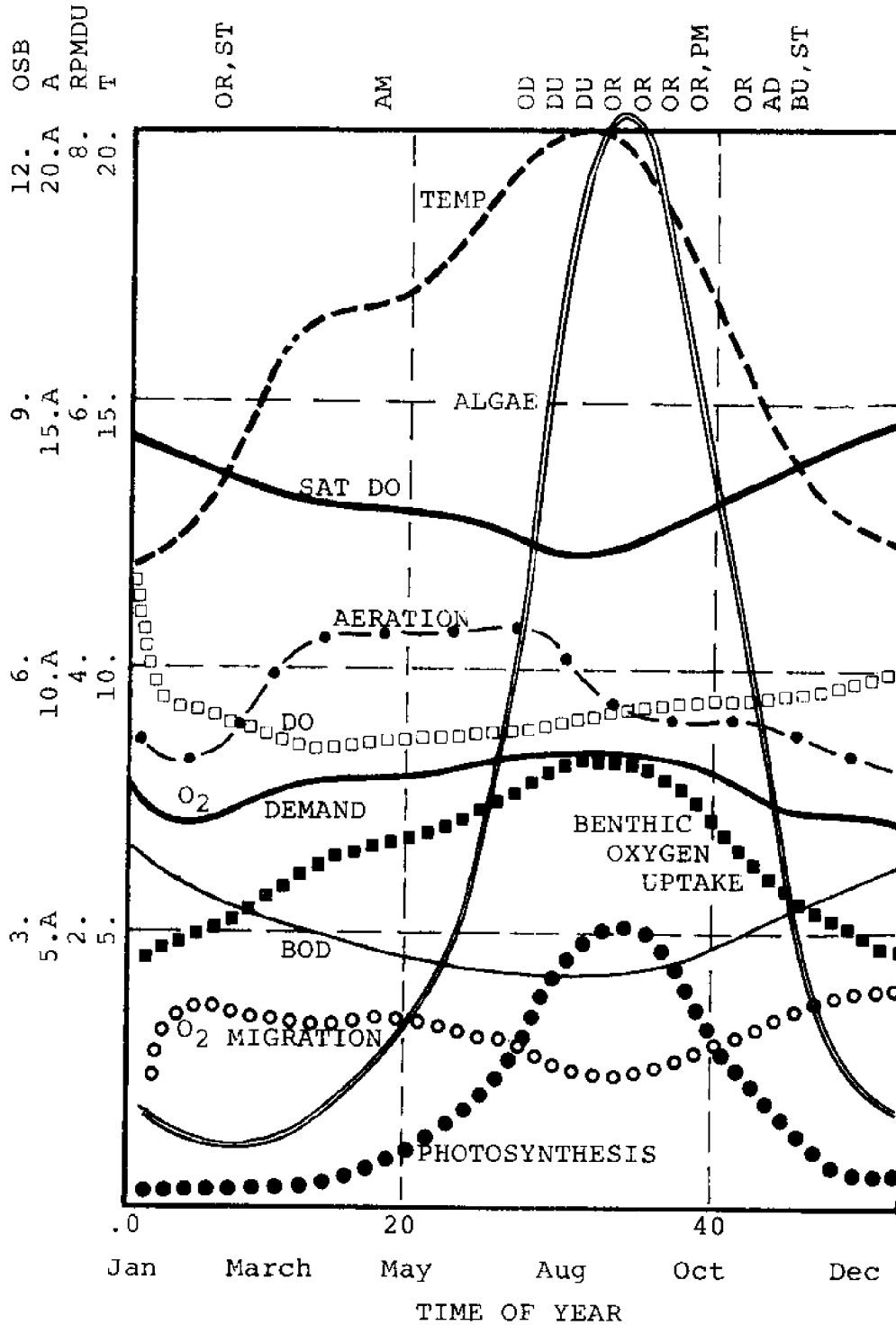

Figure A6. HAC2 with a Light Extinction Coefficient K_0 of 1.5 rather than the original value of 1.75.

photosynthesis is increased. First, photosynthesis only accounts for a small portion of DO, so that a doubling of photosynthetic activity does not lead to a doubling of DO. Second, aeration and oxygen migration are self-regulating, negative feedback effects, which means that if photosynthesis raises the amount of dissolved oxygen, then aeration and oxygen migration will be reduced because they are a function of the difference between DO and saturation DO. Since increasing photosynthesis leads to less aeration and oxygen migration, the net effect of more photosynthesis is less than might be expected if aeration and oxygen migration remained constant.

In terms of sensitivity, photosynthesis and amount of algae are sensitive to the value of the light extinction coefficient; whereas the amount of dissolved oxygen is not. In a similar but more thorough manner, it is possible to carry out sensitivity tests on other model parameters.

POLICY ANALYSIS

When a model has passed basic tests of validity and seems a useful representation of the real-world system, the model becomes available as a laboratory to test alternative policies. Policy tests are very similar to the sensitivity analysis of Figure A6. A model parameter is altered to reflect the policy and the computer output is compared to the Standard Run to see the consequences of the policy.

An important policy issue is the effect on dissolved oxygen levels of requiring secondary treatment of the wastes from the Terminal Island Treatment Plant and the fish canneries. Table A1 shows the results of a policy test using water temperature patterns appropriate to 1973 and 1974 and reducing the existing average BOD loading of 37×10^5 grams/wk to:

- (1) a value of 24×10^5 grams/wk, representing the reduction in BOD of performing secondary treatment on the Terminal Island Treatment Plant wastes alone; and
- (2) a value of 5×10^5 grams/wk, representing the reduction in BOD of performing secondary treatment on both the Terminal Island Treatment Plant wastes and the cannery wastes.

All the dissolved oxygen data in Table A1 is generated by the computer model. The values represent average levels for several months throughout the year as well as the minimum dissolved oxygen level (usually occurring in the month of August). Table A1 shows that secondary treatment of the Terminal Island wastes raises the minimum D.O. from approximately 4.9 mg/l to 5.3 mg/l, an increase of 6.6%. Combined secondary treatment of the cannery and Terminal Island wastes raises the minimum D.O. from 4.3 mg/l to 6.1 mg/l, an increase of 23%. Although secondary treatment of combined wastes leads to higher D.O. values, we must point out that several qualifications are important:

- (1) the model does not account for the possible increase in algal blooms resulting from secondary treatment of the cannery wastes; and
- (2) the model does not measure the reduced fish productivity that might result from removing the cannery wastes.

Table A1. POLICY ANALYSIS WITH HAC2: Effect of Secondary Treatment on Average Dissolved Oxygen.

Date	Existing BOD Loading	Secondary Treatment of Terminal Island Waste		Secondary Treatment of Terminal Island and Canneries Waste	
	Ave. DO (mg/l)	Av. DO (mg/l)	% Change	Ave. DO (mg/l)	% Change
<u>1973</u>					
Mar.	5.3	5.6	+ 5.1	6.4	+ 21
June	5.3	5.6	+ 5.9	6.4	+ 20
Sept	5.2	5.6	+ 6.1	6.4	+ 21
Dec.	6.0	6.3	+ 5.4	7.1	+ 19
<u>1974</u>					
Mar.	6.2	6.6	+ 5.0	7.3	+ 17
June	5.1	5.4	+ 6.4	6.2	+ 22
Sept	5.3	5.6	+ 6.1	6.4	+ 21
Dec.	6.1	6.5	+ 5.3	7.3	+ 18
Min. DO (Aug., 1973)	4.9	5.3	+ 6.6	6.1	+ 23

Note: This data was simulated by the HAC2 model using temperature patterns from 1973 and 1974.

IMPROVING THE MODEL

Model improvement has two dimensions: 1) collecting data to support assumptions in the existing model; or 2) adding structure not included in the original model.

COLLECTING DATA

Collection of data and studies that support assumptions in HAC2 is an important area for model improvement. The literature on aeration, BOD oxidation, alga growth and decay, photosynthesis, and oxygen convection and diffusion, although partially reviewed, must be further examined for relevant information. Existing data on Los Angeles Harbor has been identified and applied to the model. Where feasible and sensitivity analysis indicates, additional data will be collected to verify important model assumptions and output.

IMPROVING MODEL STRUCTURE

No model is ever complete in the sense that it represents all attributes found in the real-world system. The art of modeling is to include the most important factors in a preliminary model and then add increasingly less important factors as time and money allow.

One possible area for further study is to account for vertical and horizontal gradients in such variables as water temperature, dissolved oxygen and algal productivity. Currently, the model uses average values for these variables which could be obscuring some significant interactions.

A second area for further study deals with the phenomena of algal blooms. Representation of algal blooms requires a new model with a much shorter time horizon. The following section briefly describes a preliminary model of the algal bloom phenomena.

A FORCED ALGAL BLOOM MODEL IMPROVEMENT

Predicting the occurrence of an algal bloom is still a problem under study. Data has been collected in L.A. Harbor, however, which shows the time development pattern of a typical algal bloom. A bloom usually lasts approximately 2 weeks. The peak in algal mass reaches an approximate value of 20 to 50 x 10⁻³ chA/l. Although every bloom is different, we can simulate the affect of a "typical" bloom by artificially controlling the growth rate of algae to produce an algal mass that replicates collected data.

A typical algal bloom follows a smoothly rising curve which peaks then declining rapidly. This phenomenon may be represented as a distorted sinusoidal curve with a very sharp peak. In this preliminary model a sinusoidal input was used to "force" an algal bloom to occur. The effects of the bloom on oxygen levels could be subsequently **studied**.

The four most important assumptions in the Forced Algal Bloom Model are:

- (1) the algal bloom lasts approximately 14 days with a peak occurring on the 10th day;
- (2) the peak occurs with an algal mass of 50 x 10⁻³ mg chA/l;

- (3) as much BOD is produced during the decline phase of the bloom as was oxygen produced during the growth phase; and
- (4) photosynthetic activity or growth only occurs during daylight (assumed 6 a.m. to 6 p.m.).

A more detailed explanation of equations used in the Forced Algal Bloom Model appears in the Appendix to this paper. The Appendix also includes a documented listing of the Forced Algal Bloom Model.

FORCED ALGAE BLOOM MODEL ANALYSIS

Figure A7 depicts the Standard Run using the Forced Algae Bloom Model. The figure shows the change in Algal Mass, Dissolved Oxygen, and BOD during a typical algal bloom. Time is measured in days on the horizontal axis. The bloom starts at time equal to zero, with Algal Mass reaching a peak of 50×10^{-3} mg chlorophyll A/liter on the tenth day. The algae then dies off to a value close to zero (due to either a light or nutrient limitation on growth). During the algal growth period from day 0 to day 10, dissolved oxygen rises from a value of 5 mg/l to a value of 7 mg/l as net algae growth is positive and produces excess oxygen. BOD remains essentially constant at 2 mg/l during this period.

In Figure A7, from day 10 to day 14, Algal Mass drops rapidly with a negative net algal growth. In this model we assume that as much BOD is created during the decline phase of the bloom as was oxygen produced during the growth phase. As a consequence, BOD rises to a peak value of 5 mg/l and creates

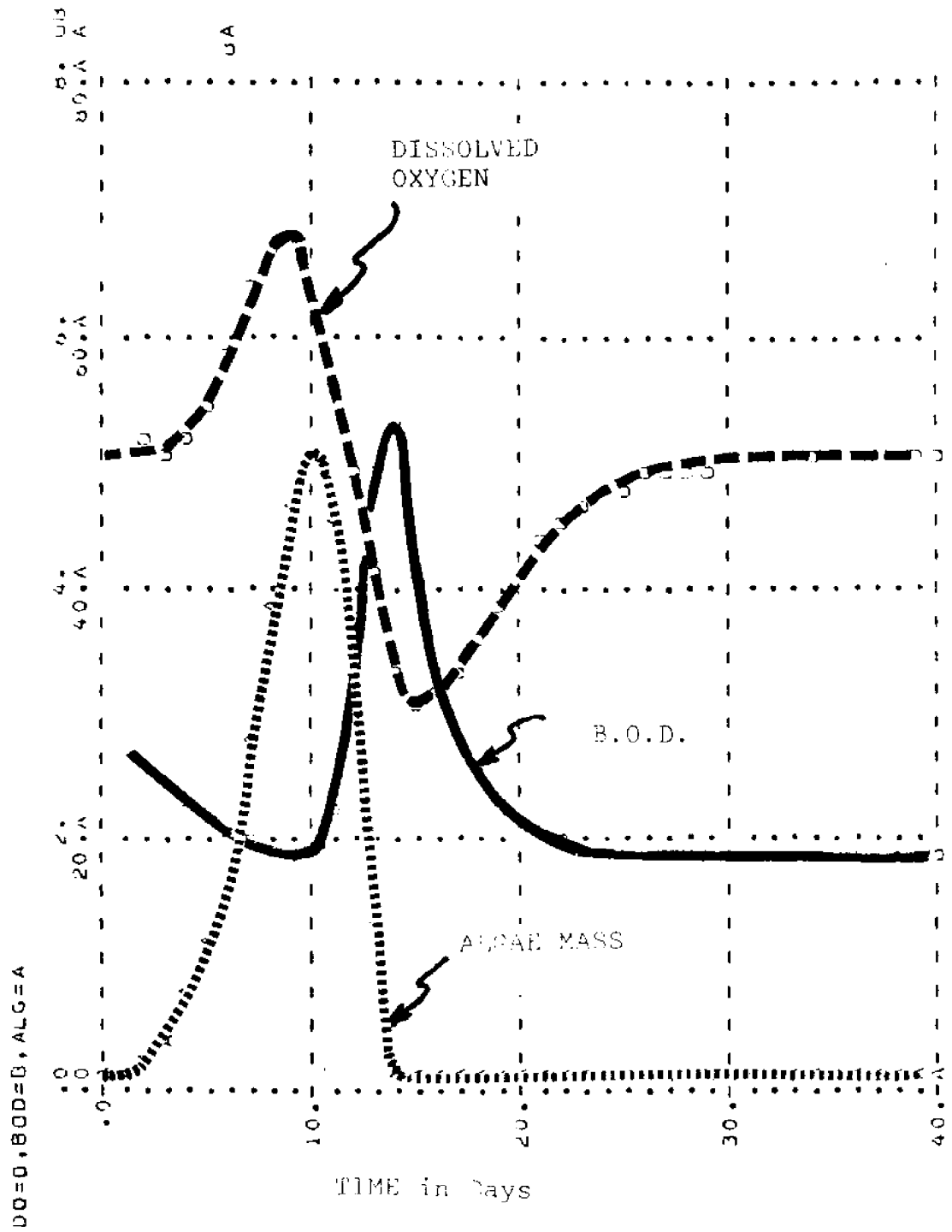

FIGURE A7 FORCED ALGAE BLOOM MODEL: STANDARD RUN
(Algae Peak = 50×10^{-3} mg chl a/l)

a large consumption of oxygen which, in turn, causes DO to drop from its peak of 7 mg/l to a minimum value of 3 mg/l and then rises back up to an equilibrium value of 5 mg/l. The final rise in DO is a result of the eventual reduction in BOD as it is biodegraded.

In terms of the sequence of events: First, Dissolved Oxygen reaches a peak approximately 2 days prior to the peak in Algal Mass and attains a minimum value five days after the peak in Algal Mass. BOD peaks approximately four days after the algae peak; so that the maximum BOD and minimum DO occur almost simultaneously.

There are a variety of different types of analysis that can be performed using the algal model. In this section we describe two tests: (1) an evaluation of the consequences of Algal Mass reaching a higher peak value; and (2) an evaluation of the effect on minimum dissolved oxygen, if during a bloom there is secondary treatment of waste material and a reduction in BOD loading.

A Higher Peak in Algal Mass

Figure A8 shows the results of forcing the algal bloom to reach a peak of 100×10^{-3} mg ch A/l as opposed to the Standard Run Value of 50×10^{-3} mg ch A/l. Such a higher peak value could possibly be achieved if there were increased nutrients made available to the algae and/or if water turbidity were reduced.

We must be careful in comparing Figures A7 and A8, since

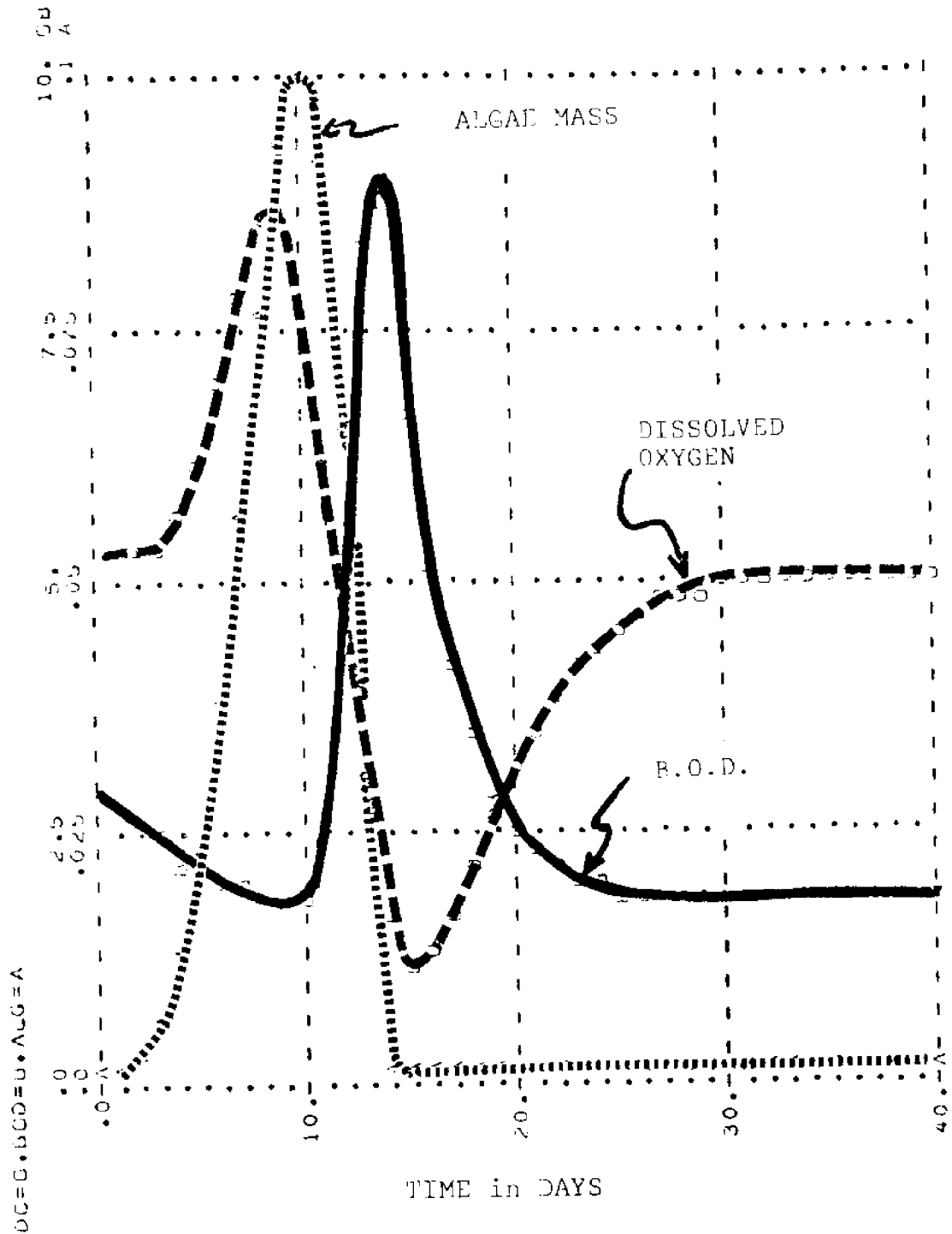

FIGURE A8 FORCED ALGAE BLOOM MODEL: INCREASED ALGAE PEAK
 (Algae Peak = 100×10^{-3} mg chl a/l)

scales on the vertical axis are different. The higher peak in Algae of Figure A8 leads to a higher peak in BOD (8.5 mg/l versus 5 mg/l in Figure A7). The higher peak in BOD, in turn, causes D.O. to reach a much lower value of 1.2 mg/l as opposed to the value of 3 mg/l in Figure 9. Doubling the peak value of the algal bloom has caused a 60% reduction in minimum dissolved oxygen. A further increase in the algae peak could lead to a zero D.O. level with development of anoxic conditions. For this reason policies in the L.A. Harbor which have the potential for either increasing the peak value or rate of occurrence of algal blooms must have strong justification.

Effect of Secondary Treatment on Minimum D.O.

Table A2 shows the results of a second policy test in which secondary treatment of wastes occurs during an algal bloom. Column one shows minimum D.O. values for three B.O.D. loadings: (1) the existing conditions; (2) B.O.D. loading if there were secondary treatment of Terminal Island wastes; and (3) B.O.D. loading if there were secondary treatment of combined Terminal Island and Cannery wastes. Table A2 shows that even if secondary treatment were applied to the combined wastes, average D.O. would still drop below the 5 mg/l level required for acceptable water quality.

TABLE A2 POLICY ANALYSIS WITH THE FORCED ALGAL BLOOM MODEL:
Effect of Secondary Treatment

BOD Loading	Min. DO (mg/l)	Max. BOD (mg/l)
Existing BOD Loading	3.1	5.3
Secondary Treatment of Terminal Island Waste	3.4	4.9
Secondary Treatment of Terminal Island and Canneries Waste	4.4	3.9

CONCLUSIONS

This paper has briefly summarized some work which applies computer simulation to determination of the oxygen assimilative capacity in L.A. Harbor. Although further data collection will improve our confidence in the model as a portrayal of the real-world system, we can still make some general conclusions as a result of the work to date:

- (1) With the exception of the deleterious effects of algal blooms, the harbor seems to be able to assimilate the current level of BOD loading; however, any large decrease in water volume through land-fill or any substantial increase in BOD loading would probably create dissolved oxygen levels below 5 mg/l.
- (2) Secondary treatment of Terminal Island Treatment Plant wastes alone will not substantially raise dissolved oxygen levels in the harbor; however, the resulting levels should be compatible with existing water quality criteria;
- (3) Secondary treatment of a combination of Terminal Island Treatment Plant and cannery wastes would substantially increase dissolved oxygen levels in the harbor; however, there are two important qualifications. First, in its present form, the model does not consider any nutrient limitation for phytoplankton growth so that possible stimulation of algal blooms from secondary treatment is not evaluated. Second, the effect on fish productivity of removing the cannery organics is also beyond the scope of the oxygen model.
- (4) Model results indicate that large algal die-offs following an algal bloom can substantially lower dissolved oxygen levels. Policies which may affect the magnitude and occurrence of blooms, therefore, require careful analysis.

APPENDIX AA

This Appendix for the paper on Quantification of the Assimilative Capacity of L.A. Harbor includes:

1. Equations for the Forced Algal Bloom Model
2. Documented Listing of HAC2
3. Documented Listing of the Forced Algal Bloom Model

Forced Algal Bloom Model

The following section briefly justifies the equations used in the Forced Algal Bloom Model. A complete listing of all equations appears at the end of this appendix (note: two documented model listings are presented in this appendix. The first is for the HAC2 Model, and the second is for the Forced Algal Bloom Model).

$$\text{ALG} = \text{ALGI} + \text{H} * \text{EXP}(-\text{DEG} * \text{TIME}) (1 - \text{COS}(\text{W} * \text{TIME})) \quad \text{Eq. A1}$$

$$\text{NAG} = \frac{d}{dt} \text{ALG}$$

$$\begin{aligned} &= \text{H} * \text{EXP}(-\text{DEG} * \text{TIME}) * (\text{W} * \text{SIN}(\text{W} * \text{TIME}) \\ &\quad - \text{DEG} * (1 - \text{COS}(\text{W} * \text{TIME}))) \end{aligned} \quad \text{Eq. A2}$$

$$\text{where } \text{H} = (\text{P} - \text{ALGI}) * \text{EXP}(\text{DEG} * \text{PT}) / (1 - \text{COS}(\text{W} * \text{PT})) \quad \text{Eq. A3}$$

$$\text{DEG} = \text{W} * \text{COS}(\text{W} * \text{PT} / 2) / \text{SIN}(\text{W} * \text{PT} / 2) \quad \text{Eq. A4}$$

$$\text{W} = 2\pi / \text{PER}$$

$$= 6.2831853 / \text{PER} \quad \text{Eq. A5}$$

$$\text{PER} = 14$$

$$\text{PT} = 10$$

$$\text{ALGI} = .0018$$

$$\text{P} = .100$$

ALG - algae (mg-chl._a/l)

ALGI - algae initial (mg-chl._a/l)

H - a constant controls the height of the curve
(mg-chl._a/l)

DEG - a constant determines the degree of distortion
of the curve (1/day)

TIME - time (day)

W - a constant, see Eq. A5(1/day)

NAG - net algal growth rate (mg-chl._a/l/day)

PER - period of the curve (day)

P - peak of the curve (mg-chl._a/day)

PT - time when peak occurs (day)

When PT is chosen to be the middle of the period

$$PT = PER/2,$$

$$DEG = 0,$$

$$H = P - ALGI,$$

$$\text{and } ALG = ALGI + H*(1 - \cos(W*TIME)) \quad \text{Eq. A6}$$

which is a symmetric sinusoidal curve with a maximum point equal to P.

When the peak is reached,

$$TIME = PT,$$

$$\frac{d}{dt}ALG = 0$$

and so, from equation A2,

$$NAG = H*EXP(-DEG*PT)*(W*SIN(W*PT)-DEG*(1-COS(W*PT)))$$

$$= 0$$

which gives

$$W*SIN(W*PT)-DEG*(1-COS(W*PT)) = 0$$

$$\text{or } DEG = W*SIN(W*PT)/(1-COS(W*PT))$$

$$= W*COT(W*PT/2)$$

Eq. A7

which gives equation A4.

The respiration rate of algae is assumed to be $0.005*TEMP$ (/day/°C) [DiToro, et al., 1971] for both day-time
Harbors Environmental Projects University of Southern California

and night-time periods. The equations are expressed as:

$$\text{ARES} = \text{ALG} * .005 * \text{TEMP} * \text{OEC} \quad \text{Eq. A8}$$

$$\text{OEC} = 130$$

$$\text{ARESDAY} = \begin{cases} \text{ARES}/2 & \text{during day-time} \\ 0 & \text{during night time} \end{cases} \quad \text{Eq. A9}$$

ARES - algal respiration rate (mg-0₂/l/day)

TEMP - temperature (°C)

OEC - oxygen equivalent of chlorophyll (mg-0₂/mg-chl.a)

ARESDAY - day-time algal respiration rate (mg-0₂/l/day)

In this simplified model we assume that when the algal mass is increasing, the total oxygen produced during the daylight period through photosynthesis equals the oxygen equivalent of the algal growth plus respiration for that daylight period:

$$\text{PHOTO} = \text{ODAY} + \text{ARESDAY} \quad \text{Eq. A10}$$

PHOTO - photosynthesis (mg-0₂/l/day)

ODAY - daytime oxygen production (mg-0₂/l/day)

The daytime production is apportioned in a sine curve around noon such that

$$\text{ODAY} = \text{TODAY} * \text{HRF} \quad \text{Eq. A11}$$

$$\text{HRF} = \begin{cases} 0 & (\text{TM} < .5) \\ \frac{\pi}{2} * \text{SIN}(2\pi * \text{TM}) & (\text{TM} \geq .5) \end{cases} \quad \text{Eq. A12}$$

$$\text{TM} = \text{TIME} - \text{D} + .25 \quad \text{Eq. A13}$$

TODAY - total daytime oxygen production (mg-0₂/l/day)

HRF - a fraction (dimensionless)

TM - clock hour, changes between 0 and 1, while TM = 0

designate 6 pm and $TM = .5$ designate the beginning of daytime, 6 am (day)

D - count of days (day)

The count of days is expressed by a level equation

$$D.K = D.J + (DT)(IN.JK) \quad \text{Eq. A14}$$

DT - delta time (day)

IN - increment (day)

A unit is added to the count whenever

$$TM \geq 1$$

i.e., whenever the clock hour passed 6 pm:

$$IN = \begin{cases} 0 & (TM < 1) \\ 1/DT & (TM \geq 1) \end{cases} \quad \text{Eq. A15}$$

The integration of the fractions,

$$\begin{aligned} \int_0^1 \text{HRF} \, d(TM) &= \frac{1}{2} \int_{.5}^1 \sin(2\pi * TM) \, d(TM) \\ &= \frac{1}{4} \cos(2\pi * TM) \Big|_{.5}^1 \\ &= \frac{1}{2} \end{aligned} \quad \text{Eq. A16}$$

which equals

$$\begin{aligned} \int_{.5}^1 d(TM) &= TM \Big|_{.5}^1 \\ &= \frac{1}{2} \end{aligned} \quad \text{Eq. A17}$$

as it should.

Total daytime oxygen production rate, TODAY, is the oxygen equivalent of the net algal growth rate when the algal mass is increasing. We assume a zero value during

the falling stage of the algal mass:

$$\text{TODAY} = \begin{cases} \text{OEQ} & (\text{NAG} \geq 0) \\ 0 & (\text{NAG} < 0) \end{cases} \quad \text{Eq. A18}$$

$$\text{OEQ} = \text{OEC} * \text{NAG}$$

$$\text{OEC} = 130$$

OEP - oxygen production equivalent (mg-0₂/l/day)

OEQ - oxygen equivalent of chlorophyll (mg-0₂/mg-chl._a)

Let NAGR and NAGF denote the net algal growth rates in the rising stage and falling stage, respectively. Then equation A2 becomes

$$\text{NAG} = \begin{cases} \text{NAGR} & (\text{TIME} < \text{PT}) \\ \text{NAGF} & (\text{TIME} \geq \text{PT}) \end{cases} \quad \text{Eq. A20}$$

$$\begin{aligned} \text{NAGF} = & \text{H} * \text{EXP}(-\text{DEG} * \text{TIME}) * (\text{W} * \text{SIN}(\text{W} * \text{TIME}) \\ & - \text{DEG} * (1 - \text{COS}(\text{W} * \text{TIME}))) \quad (\text{TIME} \geq \text{PER}) \end{aligned} \quad \text{Eq. A21}$$

$$\text{NAGR} = \text{NAGF} \quad \text{Eq. A22}$$

NAGF - net algal growth rate in the falling stage
(mg-chl._a/l/day)

NAGR - net algal growth rate in the rising stage
(mg-chl._a/l/day)

We assume that the algae grows during daytime only, and so equation A22 is modified to

$$\text{NAGR} = \begin{cases} 0 & (\text{TM} < .5) \\ \text{NAGDAY} & (\text{TM} \geq .5) \end{cases} \quad \text{Eq. A23}$$

$$\text{NAGDAY} = 2 * \text{NAGF} \quad \text{Eq. A24}$$

NAGDAY - net algal growth during daytime (mg-chl._a/l/day)

2 - a factor to make the growth rate double in the daytime and zero in the nighttime

Because the growth rate is a sinusoidal curve with respect to time, the factor 2 in equation A24 can produce a distorted value of the curve peak which is not the designed value. We found that

$$\text{NAGDAY} = 1.77 * \text{NAGF} \quad \text{Eq. A25}$$

instead of equation A24, which makes the peak value very close to the desired one.

As the algae die off, their biomass becomes oxidizable material:

$$\text{BODFA} = \begin{cases} \text{OEQ} & (\text{NAG} < 0) \\ 0 & (\text{NAG} \geq 0) \end{cases} \quad \text{Eq. A26}$$

BODFA - BOD loading from algal bloom (mg/l/day).

The oxygen production equivalent, OEQ, is calculated from equation A19.

Additional rate RESA is put into the equation of DO level,

$$\text{RESA} = \text{ARES} \quad \text{Eq. A27}$$

RESA - respiration rate of algae where ARES is calculated from equation A8

In the forced algae bloom model, the combination of equation A2 through A25 is used to replace the whole ALGAE section in the basic model. The equations A26 and A27 are used to modify the equations in the BOD section and DO section, respectively.

PAGE 1 HARBOR ASSIMILATIVE CAPACITY 2 9/28/76

DISSOLVED OXYGEN

$DO.K = DO.J + (DT) \{ AER.JK + OM.JK + PHOTO.JK - CD.JK - BCU.JK \}$ 1. L
 $DO = DOI$ 1.1. N
 $DOI = 6.7$ 1.2. C
 DO - DISSOLVED OXYGEN (MG/L)
 DT - DELTA TIME (DAYS)
 AER - AERATION (MG/L/DAY)
 OM - OXYGEN MIGRATION (MG/L/DAY)
 PHOTO - PHOTOSYNTHESIS (MG/L/DAY)
 CD - OXYGEN DEMAND (MG/L/DAY)
 BCU - BENTHIC OXYGEN UPTAKE (MG/L/DAY)
 DOI - DISSOLVED OXYGEN INITIAL (MG/L)

$AER.KL = (OSL.K - DO.K) * AERK.K$ 2. R
 AER - AERATION (MG/L/DAY)
 OSL - OXYGEN SATURATION LEVEL (MG/L)
 DO - DISSOLVED OXYGEN (MG/L)
 AERK - AERATION CONSTANT (FRACTION/DAY)

$AERK.K = AERK20 * EXP(.015775 * (STEMP.K - 20))$ 3. A
 $AERK20 = .3$ 3.1. C
 AERK - AERATION CONSTANT (FRACTION/DAY)
 AERK20 - AERATION CONSTANT AT 20 C (FRACTION/DAY)
 STEMP - SURFACE TEMPERATURE (DEGREE C)

$STEMP.K = TABLE(STEMPT, TIME.K, 0, 720, 30)$ 4. A
 $STEMPT = 12.0/12.1/15.0/17.3/15.5/18.4/19.7/19.2/$ 4.1. T
 $20.2/17.8/15.4/13.7/13.2/13.5/14.8/12.4/15.2/$
 $16.8/19.2/18.7/16.6/17.4/16.9/12.1/12.6$
 STEMP - SURFACE TEMPERATURE (DEGREE C)
 STEMPT - SURFACE TEMPERATURE TABLE (DEGREE C)
 TIME - TIME (DAY)

$OSL.K = TABLE(OSLT, STEMP.K, 0, 25, 5)$ 5. A
 $OSLT = 11.3/10/8.9/8/7.3/6.5$ 5.1. T
 OSL - OXYGEN SATURATION LEVEL (MG/L)
 OSLT - OXYGEN SATURATION LEVEL TABLE (MG/L)
 STEMP - SURFACE TEMPERATURE (DEGREE C)

$OM.KL = (OSL.K - DO.K) * FNW$ 6. R
 $FNW = .07$ 6.1. C
 OM - OXYGEN MIGRATION (MG/L/DAY)
 OSL - OXYGEN SATURATION LEVEL (MG/L)
 DO - DISSOLVED OXYGEN (MG/L)
 FNW - FRACTION OF NEW WATER (FRACTION/DAY)

$PHOTO.KL = NAG.JK * DEC$ 7. R
 $DEC = 130$ 7.1. C
 PHOTO - PHOTOSYNTHESIS (MG/L/DAY)
 NAG - NET ALGAE GROWTH (MG/L/DAY CHL.)
 DEC - OXYGEN EQUIVALENT OF CHLOROPHYLL (MG C/MG CHLOR)

PAGE 3 HARBOR ASSIMILATIVE CAPACITY 2 9/08/76

$BODM.KL=(BOD.K-BODR)*FNW$ 15. R
 $BODR=1$ 15.1. C
 BODM - BOD MIGRATION (MG/L/DAY)
 BOD - BOD (MG/L OXYGEN)
 BODR - BOD REFERENCE (MG/L)
 FNW - FRACTION OF NEW WATER (FRACTION/DAY)

$BODD.KL=BOD.K=BODK.K$ 16. R
 BODD - BOD OXIDATION (MG/L/DAY)
 BOD - BOD (MG/L OXYGEN)
 BODK - BOD CONSTANT (FRACTION/DAY)

$BODK.K=BODK20*0.25*EXP(0.0692*(MTEMP.K-20))$ 17. A
 $BODK20=.4$ 17.1. C
 BODK - BOD CONSTANT (FRACTION/DAY)
 BODK20 - BOD CONSTANT AT 20 C (FRACTION/DAY)
 MTEMP - MEAN TEMPERATURE (DEGREE C)

$MTEMP.K=TABLE(MTEMPT,TIME,K,0,720,30)$ 18. A
 $MTEMP=11.8/12.5/14.7/15.2/14.5/17.2/15.8/15.9/$ 18.1. T
 $19.5/17.8/15.3/14.1/13.1/13.3/14.3/11.4/14.2/$
 $15.4/17.2/17.3/15.6/16.9/16.9/12.2/12.4$
 MTEMP - MEAN TEMPERATURE (DEGREE C)
 MTEMPT - MEAN TEMPERATURE TABLE (DEGREE C)
 TIME - TIME (DAY)

ALGAE

$ALG.K=ALG.G/J+(DT*(NAG.JK-ALGP.JK-ALGM.JK-ADAB.JK))$ 19. L
 $ALG=ALGI$ 19.1. N
 $ALGI=1.0E+3$ 19.2. C
 ALG - ALGAE (MG/L CHLOROPHYLL)
 DT - DELTA TIME (DAYS)
 NAG - NET ALGAE GROWTH (MG/L/DAY CHL.)
 ALGP - ALGAE PREDATION (MG/L/DAY CHL.)
 ALGM - ALGAE MIGRATION (MG/L CHL.)
 ADAB - ALGAE DEATHS AFTER A BLOOM (MG/L/DAY)
 ALGI - ALGAE INITIAL (MG/L CHL.)

$NAG.KL=E.C.K*ALG.K$ 20. R
 NAG - NET ALGAE GROWTH (MG/L/DAY CHL.)
 G - GROWTH FACTOR FOR ALGAE (FRACTION/DAY)
 ALG - ALGAE (MG/L CHLOROPHYLL)

$G.K=((0.15)*(E*F.K)/(K.K*DEPTH))*(EXP((-I.K/IOPT))-EXP((-K.K*DEPTH)))-EXP(-I.K/IOPT))*GMAX.K$ 21. A
 $G=$
 $E=$
 $F=$
 $K=$
 $DEPTH=$
 $I=$
 $IOPT=$
 $GMAX=$
 G - GROWTH FACTOR FOR ALGAE (FRACTION/DAY)
 E - NATURAL BASE (DIMENSIONLESS)
 F - PHOTO PERIOD (DIMENSIONLESS)
 K - EXTINGUISH COEFFICIENT (1/METER)
 DEPTH - DEPTH (METERS)
 I - LIGHT INTENSITY (G CAL/SG CM/DAY)
 IOPT - LIGHT INTENSITY OPTIMAL (G CAL/SG CM/DAY)
 GMAX - GROWTH FACTOR MAXIMUM (FRACTION/DAY)

GMAX.K=.59*EXP(0.0633*STEMP.K) 22. A
 E=EXP(1) 22.1. N
 GMAX - GROWTH FACTOR MAXIMUM (FRACTION/DAY)
 STEMP - SURFACE TEMPERATURE (DEGREE C)
 E - NATURAL BASE (DIMENSIONLESS)

F.K=TABLE(FT,TIME,K,0,1080,30) 23. A
 FT=.415/.440/.473/.522/.563/.594/.599/.576/.537/ 23.1. T
 .494/.451/.420/.415/.440/.479/.522/.563/.594/
 .599/.576/.537/.494/.451/.420/.415/.440/.478/
 .522/.563/.594/.599/.576/.537/.494/.451/.420/.415
 F - PHOTO PERIOD (DIMENSIONLESS)
 FT - PHOTO PERIOD TABLE (DIMENSIONLESS)
 TIME - TIME (DAY)

K.K=K0+0.084*EXP(.667*LOGN(1E3*ALG.K))+0.0088*1E3* 24. A
 ALG.K
 K0=1.75 24.1. C
 K - EXTINCTION COEFFICIENT (1/METER)
 K0 - K WITH ZERO ALGAE SHADING (1/METER)
 ALG - ALGAE (MG/L CHLOROPHYLL)

I.K=2*ICPT 25. A
 ICPT=1 25.1. C
 I - LIGHT INTENSITY (G CAL/SQ CM/DAY)
 ICPT - LIGHT INTENSITY OPTIMAL (G CAL/SQ CM/DAY)

ALCP.KL=APF*ALG.K 26. R
 APF=.04 26.1. C
 ALCP - ALGAE PRODUCTION (MG/L/DAY CHL.)
 APF - ALGAE PRODUCTION FACTOR (FRACTION/DAY)
 ALG - ALGAE (MG/L CHLOROPHYLL)

ALCM.KL=(ALG.K-ALGR)*FNW 27. R
 ALGR=0.5E-3 27.1. C
 ALCM - ALGAE MIGRATION (MG/L CHL.)
 ALG - ALGAE (MG/L CHLOROPHYLL)
 ALGR - ALGAE REFERENCE (MG/L CHL.)
 FNW - FRACTION OF NEW WATER (FRACTION/DAY)

ADAB.KL=TABLE(ADABT,TIME,K,0,720,60) 28. R
 ADABT=0/0/0/0/0/0/0/0/0/0/0/0/0/0/0 28.1. T
 ADAB - ALGAE DEATHS AFTER A BLOOM (MG/L/DAY)
 ADABT - TABLE OF ALGAE DEATH AFTER A BLOOM (MG/L/
 DAY)
 TIME - TIME (DAY)

SPECIFICATIONS

SPEC DT=1/LENGTH=720/PLTPER=15/PRINTER=15 28.6
 DT - DELTA TIME (DAYS)
 LENGTH - END TIME OF PROGRAM (DAY)
 PLTPER - PLOT PERIOD (DAY)
 PRINTER - PRINT PERIOD (DAY)

PAGE 5 HARBOR ASSIMILATIVE CAPACITY 2 9/09/76

PLDT DD=0,BOD=E(0,8)/ALG=A(0,10E-?) 28.7
 DD - DISSOLVED OXYGEN (MG/L)
 BOD - BOD (MG/L OXYGEN)
 ALG - ALGAE (MG/L CHLOROPHYLL)

PRINT DD/BOD/ALG 28.8
 DD - DISSOLVED OXYGEN (MG/L)
 BOD - BOD (MG/L OXYGEN)
 ALG - ALGAE (MG/L CHLOROPHYLL)

NAME	NO	T	DEFINITION
PAGE 1			HARBOR ASSIMILATIVE CAPACITY 2 9/08/76
ADAB	28	R	ALGAE DEATHS AFTER A BLOOM (MG/L/DAY)
ADABT	28.1	T	TABLE OF ALGAE DEATH AFTER A BLOOM (MG/L/DAY)
AER	2	R	AERATION (MG/L/DAY)
AERK	3	A	AERATION CONSTANT (FRACTION/DAY)
AERK20	3.1	C	AERATION CONSTANT AT 20 C (FRACTION/DAY)
ALG	19	L	ALGAE (MG/L CHLOROPHYLL)
	19.1	N	
ALGI	19.2	C	ALGAE INITIAL (MG/L CHL.)
ALGM	27	R	ALGAE MIGRATION (MG/L CHL.)
ALGP	26	R	ALGAE PREDATION (MG/L/DAY CHL.)
ALGR	27.1	C	ALGAE REFERENCE (MG/L CHL.)
APF	26.1	C	ALGAE PREDATION FACTOR (FRACTION/DAY)
BOD	11	L	BOD (MG/L OXYGEN)
	11.1	N	
BODFA	14	R	BOD FROM ALGAE BLOOMS (MG/L/DAY)
BODI	11.2	C	BOD INITIAL (MG/L)
BODK	17	A	BOD CONSTANT (FRACTION/DAY)
BODK20	17.1	C	BOD CONSTANT AT 20 C (FRACTION/DAY)
BODL	12	R	BOD LOADING (MG/L/DAY)
BODLT	12.1	T	BOD LOADING TABLE (MG/L/DAY)
BODM	15	R	BOD MIGRATION (MG/L/DAY)
BODO	16	R	BOD OXIDATION (MG/L/DAY)
BODR	15.1	C	BOD REFERENCE (MG/L)
BOU	9	R	BENTHIC OXYGEN UPTAKE (MG/L/DAY)
BOU20	9.1	C	BENTHIC OXYGEN UPTAKE AT 20 C (GRAMS/SQ METER/DAY)
STEMP	10	A	BOTTOM TEMPERATURE (DEGREE C)
STEMPT	10.1	T	BOTTOM TEMPERATURE TABLE (DEGREE C)
DEPTH	13.2	C	DEPTH (METERS)
DO	1	L	DISSOLVED OXYGEN (MG/L)
	1.1	N	
DOI	1.2	C	DISSOLVED OXYGEN INITIAL (MG/L)
DT			DELTA TIME (DAYS)
E	22.1	N	NATURAL BASE (DIMENSIONLESS)
F	23	A	PHOTO PERIOD (DIMENSIONLESS)
FABOD	14.1	C	FRACTION ALGAE DEATHS TO BOD (DIMENSIONLESS)
FNW	6.1	C	FRACTION OF NEW WATER (FRACTION/DAY)
FT	23.1	T	PHOTO PERIOD TABLE (DIMENSIONLESS)
G	21	A	GROWTH FACTOR FOR ALGAE (FRACTION/DAY)
GMAX	22	A	GROWTH FACTOR MAXIMUM (FRACTION/DAY)
I	25	A	LIGHT INTENSITY (G CAL/SQ CM/DAY)
IDPT	25.1	C	LIGHT INTENSITY OPTIMAL (G CAL/SQ CM/DAY)
K	24	A	EXTINCTION COEFFICIENT (1/METER)
KD	24.1	C	K WITH ZERO ALGAE SHADING (1/METER)
LENGTH			END TIME OF PROGRAM (DAY)
MTEMP	18	A	MEAN TEMPERATURE (DEGREE C)
MTEMPT	18.1	T	MEAN TEMPERATURE TABLE (DEGREE C)
NAG	20	R	NET ALGAE GROWTH (MG/L/DAY CHL.)
OD	8	R	OXYGEN DEMAND (MG/L/DAY)
OEC	7.1	C	OXYGEN EQUIVALENT OF CHLOROPHYLL (MG O/MG CHLOR)
OM	6	R	OXYGEN MIGRATION (MG/L/DAY)
OSL	5	A	OXYGEN SATURATION LEVEL (MG/L)
OSLT	5.1	T	OXYGEN SATURATION LEVEL TABLE (MG/L)

PAGE 2 HARBOR ASSIMILATIVE CAPACITY 2 9/08/76

PHOTO	7	R	PHOTOSYNTHESIS (MG/L/DAY)
PLTPER			PLUT PERIOD (DAY)
PRTPER			PRINT PERIOD (DAY)
SA	13.1	C	SURFACE AREA (SQ METER)
STEMP	4	A	SURFACE TEMPERATURE (DEGREE C)
STEMPT	4.1	T	SURFACE TEMPERATURE TABLE (DEGREE C)
TIME			TIME (DAY)
VOL	13	A	CONTROL VOLUME (METER CUBED)

FORCED ALGAL BLOOM MODEL

PAGE 1

9/08/76

DISSOLVED OXYGEN

$DO.K = DO.J + (DT) (AER.JK + CM.JK + PHOTO.JK - OD.JK - BOU.JK - RESA.JK)$ 1. L
 DO=DO1 1.1. N
 DO1=6.7 1.2. C
 DO - DISSOLVED OXYGEN (MG/L)
 DT - DELTA TIME (DAYS)
 AER - AERATION (MG/L/DAY)
 CM - OXYGEN MIGRATION (MG/L/DAY)
 PHOTO - PHOTOSYNTHESIS (MG/L/DAY)
 OD - OXYGEN DEMAND (MG/L/DAY)
 BOU - BENTHIC OXYGEN UPTAKE (MG/L/DAY)
 RESA - RESPIRATION RATE OF ALGAE (MG/L OXYGEN)
 DO1 - DISSOLVED OXYGEN INITIAL (MG/L)

$AER.KL = (OSL.K - DO.K) * AERK.K$ 2. R
 AER - AERATION (MG/L/DAY)
 OSL - OXYGEN SATURATION LEVEL (MG/L)
 DO - DISSOLVED OXYGEN (MG/L)
 AERK - AERATION CONSTANT (FRACTION/DAY)

$AERK.K = AERK20 * EXP(.015775 * (TEMP.K - 20))$ 3. A
 AERK20=.3 3.1. C
 AERK - AERATION CONSTANT (FRACTION/DAY)
 AERK20 - AERATION CONSTANT AT 20 C (FRACTION/DAY)
 TEMP - TEMPERATURE (DEGREE C)

$TEMP.K = TABLE(TEMP.TEMP.K, C, 90, 90)$ 4. A
 TEMP=16/16 4.1. T
 TEMP - TEMPERATURE (DEGREE C)
 TEMP.TEMP - TEMPERATURE TABLE (DEGREE C)
 TIME - TIME (DAY)

$OSL.K = TABLE(OSL.T, TEMP.K, C, 25, 5)$ 5. A
 OSLT=11.3/10/9.9/3/7.2/6.5 5.1. T
 OSL - OXYGEN SATURATION LEVEL (MG/L)
 OSLT - OXYGEN SATURATION LEVEL TABLE (MG/L)
 TEMP - TEMPERATURE (DEGREE C)

$OM.KL = (OSL.K - DO.K) * FNW$ 6. R
 FNW=.07 6.1. C
 OM - OXYGEN MIGRATION (MG/L/DAY)
 OSL - OXYGEN SATURATION LEVEL (MG/L)
 DO - DISSOLVED OXYGEN (MG/L)
 FNW - FRACTION OF NEW WATER (FRACTION/DAY)

$PHOTO.KL = ODAY.K - ARESDAY.K$ 7. R
 PHOTO - PHOTOSYNTHESIS (MG/L/DAY)
 ODAY - OXYGEN PRODUCTION IN DAY-TIME (MG/L/DAY OXYGEN)
 ARESDAY - ALGAL RESPIRATION RATE DURING DAY-TIME (MG/L/DAY OXYGEN)

FORCED ALGAL BLOOM MODEL

PAGE 2

9/08/76

$OD.KL = BOD.K * BODK.K * DOM.K$ 8. R
 OD - OXYGEN DEMAND (MG/L/DAY)
 BOD - BOD (MG/L OXYGEN)
 BODK - BOD CONSTANT (FRACTION/DAY)
 DOM - DO MULTIPLIER (FRACTION)

$DOM.K = TABHL(DOMT, .4343 * LOGN(DO.K), -4.5, .5, 5)$ 9. A
 $DOMT = 0/1$ 9.1. T
 DOM - DO MULTIPLIER (FRACTION)
 DOMT - DO MULTIPLIER TABLE (FRACTION)
 DO - DISSOLVED OXYGEN (MG/L)

$BODU.KL = (BODU20 * 0.25 * EXP(0.0692 * TEMP.K)) / DEPTH$ 10. R
 DEPTH = 10 10.1. C
 BODU20 = 4.8 10.2. C
 BODU - BENTHIC OXYGEN UPTAKE (MG/L/DAY)
 BODU20 - BENTHIC OXYGEN UPTAKE AT 20 C (GRAMS/50
 METER/DAY)
 TEMP - TEMPERATURE (DEGREE C)
 DEPTH - DEPTH (METERS)

$RESA.KL = ARS.K$ 11. R
 RESA - RESPIRATION RATE OF ALGAE (MG/L OXYGEN)
 ARS - ALGAL RESPIRATION RATE (MG/L/DAY OXYGEN)

BOD

$BOD.K = BOD.U * (DT) * (BODL.UK + BODFA.UK - BODM.UK - BODD.UK)$ 12. L
 $BOD = BODI$ 12.1. N
 $BODI = .4$ 12.2. C
 BOD - BOD (MG/L OXYGEN)
 DT - DELTA TIME (DAYS)
 BODL - BOD LOADING (MG/L/DAY)
 BODFA - BOD FROM ALGAE BLOOMS (MG/L/DAY)
 BODM - BOD MIGRATION (MG/L/DAY)
 BODD - BOD OXIDATION (MG/L/DAY)
 BODI - BOD INITIAL (MG/L)

$BODL.KL = (TABLE(BDLT, TIME.K, 0.40, 40) * CONV) / VOL$ 13. R
 $BDLT = 35E6 / 35E6$ 13.1. T
 $VOL = 61E6$ 13.2. C
 $CONV = 1 / (1 - EXP(-5 * BODK20))$ 13.3. N
 $BODK20 = .4$ 13.4. C
 BODL - BOD LOADING (MG/L/DAY)
 BDLT - BOD LOADING TABLE (MG/L/DAY)
 TIME - TIME (DAY)
 CONV - A FACTOR CONVERT 5-DAY BOD TO ULTIMATE BOD
 (FRACTION)
 VOL - CONTROL VOLUME (METER CUBED)
 BODK20 - BOD CONSTANT AT 20 C (FRACTION/DAY)

$BODFA.KL = 0 - MIN(0, DEG.K)$ 14. R
 BODFA - BOD FROM ALGAE BLOOMS (MG/L/DAY)
 DEG - OXYGEN EQUIVALENT OF ALGAL GROWTH (MG/L/DAY
 OXYGEN)

FORCED ALGAL BLOOM MODEL

PAGE 3

9/08/76

$BDDM.KL = (BCD.K - EDDR) * FNW$ 15. R
 $BDDR = 1$ 15.1. C
 BDDM - BOD MIGRATION (MG/L/DAY)
 BOD - BOD (MG/L OXYGEN)
 BDDR - BOD REFERENCE (MC/L)
 FNW - FRACTION OF NEW WATER (FRACTION/DAY)

$BDDO.KL = BCD.K * BCDK.K * DCM.K$ 16. R
 BDDO - BOD OXIDATION (MG/L/DAY)
 BOD - BOD (MG/L OXYGEN)
 BCDK - BOD CONSTANT (FRACTION/DAY)
 DCM - DO MULTIPLIER (FRACTION)

$BODK.K = BODK20 * \exp(.0459 * (TEMP.K - 20))$ 17. A
 BODK - BOD CONSTANT (FRACTION/DAY)
 BODK20 - BOD CONSTANT AT 20 C (FRACTION/DAY)
 TEMP - TEMPERATURE (DEGREE C)

ALGAE

$ALG.K = ALG.J + (DT) * (NAG.JK)$ 18. L
 $ALG = ALGI$ 18.1. N
 $ALGI = 1.8E-3$ 18.2. C
 ALG - ALGAE (MC/L CHLOROPHYLL)
 DT - DELTA TIME (DAYS)
 NAG - NET ALGAE GROWTH (MG/L/DAY CHL.)
 ALGI - ALGAE INITIAL (MG/L CHL.)

$NAG.KL = \text{CLIP}(NAGF.K, NAGR.K, TIME.K, PT)$ 19. R
 $PT = 10$ 19.1. C
 NAG - NET ALGAE GROWTH (MG/L/DAY CHL.)
 NAGF - NET ALGAL GROWTH IN FALLING STAGE (MG/L/DAY CHL.)
 NAGR - NET ALGAL GROWTH IN RISING STAGE (MG/L/DAY CHL.)
 TIME - TIME (DAY)
 PT - PEAK TIME (DAY)

$NAGR.K = \text{CLIP}(NAGDAY.K, 0, TM.K, .5)$ 20. A
 NAGR - NET ALGAL GROWTH IN RISING STAGE (MG/L/DAY CHL.)
 NAGDAY - NET ALGAL GROWTH DURING DAY-TIME (MG/L/DAY CHL.)
 TM - CLOCK HOUR IN A DAY (DAY)

$TM.K = TIME.K - D.K + .25$ 21. A
 TM - CLOCK HOUR IN A DAY (DAY)
 TIME - TIME (DAY)
 D - COUNT OF DAYS (DAY)

$D.K = D.J + (DT) * (IN.JK)$ 22. L
 $D = 0$ 22.1. N
 D - COUNT OF DAYS (DAY)
 DT - DELTA TIME (DAYS)
 IN - INCREMENT OF THE COUNT OF DAYS (DAY)

FORCED ALGAL BLOOM MODEL

PAGE 4

9/08/76

$IN.K = CLIP(1.0, TM.K, 1) / DT$ 23, R
 IN - INCREMENT OF THE COUNT OF DAYS (DAY)
 TM - CLOCK HOUR IN A DAY (DAY)
 DT - DELTA TIME (DAYS)

$NAGDAY.K = 1.77 * NAGF.K$ 24, A
 NAGDAY - NET ALGAL GROWTH DURING DAY-TIME (MG/L/DAY CHL.)
 NAGF - NET ALGAL GROWTH IN FALLING STAGE (MG/L/DAY CHL.)

$NAGF.K = CLIP(0, H * EXP(-DEG * TIME.K) * (W * SIN(W * TIME.K) -$ 25, A
 $DEG * (1 - COS(W * TIME.K))), TIME.K, PER)$
 $H = (P - ALGI) * EXP(DEG * PT) / (1 - COS(W * PT))$ 25.2, N
 $P = 50E-3$ 25.3, C
 $DEG = W * COS(W * PT / 2) / SIN(W * PT / 2)$ 25.4, N
 $W = 6.2831853 / PER$ 25.5, N
 $PER = 14$ 25.6, C
 NAGF - NET ALGAL GROWTH IN FALLING STAGE (MG/L/DAY CHL.)
 H - HEIGHT OF CURVE (MG/L CHL.)
 DEG - DEGREE OF DISTORTION OF CURVE (1/DAY)
 TIME - TIME (DAY)
 W - A CONSTANT EQUALS 6.2831853/PER (1/DAY)
 PER - PERIOD OF CURVE (DAY)
 P - PEAK OF CURVE (MG/L CHL.)
 ALGI - ALGAE INITIAL (MG/L CHL.)
 PT - PEAK TIME (DAY)

$ARESDAY.K = CLIP(ARES.K / 2.0, TM.K, .5)$ 26, A
 ARESDAY - ALGAL RESPIRATION RATE DURING DAY-TIME (MG/L/DAY OXYGEN)
 ARES - ALGAL RESPIRATION RATE (MG/L/DAY OXYGEN)
 TM - CLOCK HOUR IN A DAY (DAY)

$ARES.K = ALG.K * .005 * TEMP.K * DEC$ 27, A
 ARES - ALGAL RESPIRATION RATE (MG/L/DAY OXYGEN)
 ALG - ALGAE (MG/L CHLOROPHYLL)
 TEMP - TEMPERATURE (DEGREE C)
 DEC - OXYGEN EQUIVALENT OF CHLOROPHYLL (MG O₂/MG CHLOR)

$ODAY.K = TODAY.K * PRF.K$ 28, A
 ODAY - OXYGEN PRODUCTION IN DAY-TIME (MG/L/DAY OXYGEN)
 TODAY - TOTAL OXYGEN PRODUCTION IN DAY-TIME (MG/L/DAY OXYGEN)
 PRF - HOURLY RATE FRACTION (FRACTION)

FORCED ALGAL BLOOM MODEL

PAGE 1

9/08/76

NAME	NO	T	DEFINITION
AER	2	R	AERATION (MG/L/DAY)
AERK	3	A	AERATION CONSTANT (FRACTION/DAY)
AERK20	3.1	C	AERATION CONSTANT AT 20 C (FRACTION/DAY)
ALG	18	L	ALGAE (MG/L CHLOROPHYLL)
	18.1	N	
ALGI	18.2	C	ALGAE INITIAL (MG/L CHL.)
ARES	27	A	ALGAL RESPIRATION RATE (MG/L/DAY OXYGEN)
ARESDAY	26	A	ALGAL RESPIRATION RATE DURING DAY-TIME (MG/L/DAY OXYGEN)
BOD	12	L	BOD (MG/L OXYGEN)
	12.1	N	
BODFA	14	R	BOD FROM ALGAE PLEOMBS (MG/L/DAY)
BODI	12.2	C	BODINITIAL (MG/L)
BODK	17	A	BOD CONSTANT (FRACTION/DAY)
BODK20	17.4	C	BOD CONSTANT AT 20 C (FRACTION/DAY)
BODL	13	R	BOD LOADING (MG/L/DAY)
BODLT	13.1	T	BOD LOADING TABLE (MG/L/DAY)
BODM	15	R	BOD MIGRATION (MG/L/DAY)
BODO	16	R	BOD OXIDATION (MG/L/DAY)
BODR	15.1	C	BOD REFERENCE (MG/L)
BOU	10	R	BENTHIC OXYGEN UPTAKE (MG/L/DAY)
BOU20	10.2	C	BENTHIC OXYGEN UPTAKE AT 20 C (GRAMS/SQ METER/DAY)
CONV	12.3	N	A FACTOR CONVERT 5-DAY BOD TO ULTIMATE BOD (FRACTION)
D	22	L	COUNT OF DAYS (DAY)
	22.1	N	
DEG	25.4	N	DEGREE OF DISTORTION OF CURVE (1/DAY)
DEPTH	10.1	C	DEPTH (METERS)
DO	1	L	DISSOLVED OXYGEN (MG/L)
	1.1	N	
DOI	1.2	C	DISSOLVED OXYGEN INITIAL (MG/L)
DOM	9	A	DO MULTIPLIER (FRACTION)
DOMT	9.1	T	DO MULTIPLIER TABLE (FRACTION)
DT			DELTA TIME (DAYS)
FNW	6.1	C	FRACTION OF NEW WATER (FRACTION/DAY)
H	25.2	N	HEIGHT OF CURVE (MG/L CHL.)
HRF	29	A	HOURLY RATE FRACTION (FRACTION)
HRFT	29.1	T	HOURLY RATE FRACTION TABLE (FRACTION)
IN	23	R	INCREMENT OF THE COUNT OF DAYS (DAY)
LENGTH			END TIME OF PROGRAM (DAY)
NAG	19	R	NET ALGAE GROWTH (MG/L/DAY CHL.)
NAGDAY	24	A	NET ALGAL GROWTH DURING DAY-TIME (MG/L/DAY CHL.)
NAGF	25	A	NET ALGAL GROWTH IN FALLING STAGE (MG/L/DAY CHL.)
NAGR	20	A	NET ALGAL GROWTH IN RISING STAGE (MG/L/DAY CHL.)
OD	8	R	OXYGEN DEMAND (MG/L/DAY)
ODAY	28	A	OXYGEN PRODUCTION IN DAY-TIME (MG/L/DAY OXYGEN)
DEC	31.1	C	OXYGEN EQUIVALENT OF CHLOROPHYLL (MG O ₂ /MG CHLOR)
DEG	31	A	OXYGEN EQUIVALENT OF ALGAL GROWTH (MG/L/DAY OXYGEN)
DM	6	R	OXYGEN MIGRATION (MG/L/DAY)

FORCED ALGAL BLOOM MODEL

PAGE 2

9/08/76

OSL	5	A	OXYGEN SATURATION LEVEL (MG/L)
OSLT	5.1	T	OXYGEN SATURATION LEVEL TABLE (MG/L)
P	25.3	C	PEAK OF CURVE (MG/L CHL.)
PER	25.6	C	PERIOD OF CURVE (DAY)
PHOTO	7	R	PHOTOSYNTHESIS (MG/L/DAY)
PLTPER			PLCT PERIOD (DAY)
PRTRPER			PRINT PERIOD (DAY)
PT	19.1	C	PEAK TIME (DAY)
RESA	11	R	RESPIRATION RATE OF ALGAE (MG/L OXYGEN)
TEMP	4	A	TEMPERATURE (DEGREE C)
TEMPT	4.1	T	TEMPERATURE TABLE (DEGREE C)
TI	29.3	N	TIME INTERVAL (DAY)
TIME			TIME (DAY)
TM	21	A	CLOCK HOUR IN A DAY (DAY)
TODAY	30	A	TOTAL OXYGEN PRODUCTION IN DAY-TIME (MG/L/DAY OXYGEN)
VOL	17.2	C	CONTROL VOLUME (METER CUBED)
W	25.5	N	A CONSTANT EQUALS 6.2831853/PER (1/DAY)

LITERATURE CITED

- Bailey, Thomas E. 1970. Estuarine oxygen resources - photosynthesis and reaeration. ASCE Sanitary Eng. Div. 96 SA2:279-296.
- Chen, C.W. 1970. Concepts and utilities of ecologic modeling. Journal of Sanitary Engineering Div. ASCE Vol. 96 No. SA5.
- DiToro, D.M., D.J. O'Conner, and R.V. Thomann. 1971. A dynamic model of phytoplankton populations in the Sacramento-San Joaquin Delta. Adv. in Chem. 106:131-180.
- Eppley, R.W. 1972. Temperature and phytoplankton in the sea. Fish. Bull. 70:1063-1085.
- Fair, G.W., J.C. Geyer, and D.A. Okun. 1968. Water and wastewater engineering. John Wiley and Sons, Inc., New York.
- Hargrave, B.T. 1969. Similarity of oxygen uptake by benthic communities. Limnol. Oceanogr. 14:801-805.
- Nixon, S.W., C.A. Oviatt, and S.S. Hale. In press. Nitrogen regeneration and the metabolism of coastal marine bottom communities. Symp. of Decomposition, British Ecological Society, Coleraine No. Ireland. April, 1975.
- Pamatmat, M.M. 1968. Ecology and metabolism of a benthic community on an intertidal sandflat. Int. Rev. Ges. Hydrobiol. 53:211-298.
- Parsons, T.R., K.Stevens, and J.D.H.Strickland. 1961. On the chemical composition of 11 species of marine phytoplankters. J. Fish. Res. Bd. Can. 18:1001-1016.
- Pugh, A. 1970. DYNAMO II user's manual. MIT Press, Cambridge, Mass.
- Riley, G.A. Theory of food chain relations in the ocean. In The Sea. M.N. Hill, ed. vol. 2:438-463. Interscience, New York.
- Soule, Dorothy and M.Oguri, eds. Marine Studies of San Pedro Bay, California. Allan Hancock Foundation and Office of Sea Grant Programs, University of Southern California.
- 1973 Biological Investigations: Preliminary investigations of the role of cannery wastes in the Los Angeles Harbor. Part 2.
- 1974 Data Report. Temperature, salinity, oxygen, and pH in outer Los Angeles Harbor. Part 5.

PART B.

THE IMPACT OF WASTE EFFLUENTS ON THE BENTHOS
AND FOOD HABITS OF FISH
IN OUTER LOS ANGELES HARBOR

by

Donald J. Reish and Richard Ware
Department of Biology, California State University
Long Beach, California 90720

THE IMPACT OF WASTE EFFLUENTS ON THE BENTHOS
AND FOOD HABITS OF FISH
IN OUTER LOS ANGELES HARBOR

by

Donald J. Reish and Richard Ware
Department of Biology, California State University
Long Beach, California 90720

INTRODUCTION

The present study was initiated to investigate dietary content of the large fish populations present in the vicinity of the fish cannery and Terminal Island sewage outfalls in order to determine whether these discharges contribute a food source, directly or indirectly through an invertebrate food chain, to the large population of fish inhabiting the area. Many of the fish species are bottom feeders, either primarily or gratuitously.

The area out from the Terminal Island and fish cannery outfalls can be divided into three zones on the basis of benthic species present (Reish, 1959; Allan Hancock Foundation, 1975). The inner zone, which may be termed polluted zone or impoverished zone, extends from about the entrance of the seaplane base to the outer Fish Harbor jetty. It is characterized by the polychaete *Capitella capitata* and a few other pollution-tolerant species. Fish caught in this zone were feeding upon *Capitella capitata*, *Armandia bioculata*, and harpacticoid copepods.

A zone of enrichment, or semi-healthy zone, is found immediately outside the impoverished zone. It is characterized by a

large population of many species of polychaetes, especially *Pseudopolydora paucibranchiata*, *Schistomeringos longicornis*, and *Cirriformia luxuriosa*. Crustaceans and molluscans are also present in this zone. The fish population is larger here than in any other place in Los Angeles-Long Beach Harbors. The fish caught in this zone fed upon a large variety of benthic invertebrates.

A normal or healthy zone is present out from the zone of enrichment. This zone extends throughout much of the outer harbor area and beyond the breakwater. The normal community contains representatives from most of the animal phyla and is characterized by the polychaete indicators *Tharyx* sp. and *Cossura candida*. While the diversity of life is greater here, the total biomass was less than in the zone of enrichment. The fish population is diverse but sparser in comparison to the zone of enrichment. Zones of enrichment are often found some distance away from a sewage effluent. This is probably influenced by the addition of some organic matter, but not too much, diluted to an optimal level by circulation and diffusion. The outer harbor study area comprises all three zones: (1) a polluted zone near the cannery and Terminal Island effluent discharges; (2) a semi-healthy zone which is located adjacent to the influx of these discharges, near trawl stations 4, 5, and 7; and (3) a healthy zone at the outer trawl sites, stations 6, 8, and 9 (Fig. B1).

METHODS

Fish trawls were taken four times between October, 1975 and March, 1976 at the stations indicated in Figure B1. Each species was sorted onboard ship according to size class and diseases, if present. Ten fish from each size class of all species were randomly selected and their digestive tract injected with 10 percent formalin. In the laboratory the fish were weighed and measured. In addition the coefficient of condition (K) was determined by the formula:

$$K = \frac{\text{weight in grams}}{\text{standard body length in millimeters}^3}$$

Higher K values indicate that the fish are heavier for their body length than others of the same length. The species of fish caught are given in Table B2. The contents of both stomach and intestine were analyzed and the organisms identified as far down as possible.

Benthic samples were taken at each trawl station with a 0.1m² modified Campbell grab. These samples were preserved and later in the laboratory washed through a 0.5 mm screen and sorted to species.

RESULTS

A total of 28 species of fish have been taken. Gut contents have been analyzed for 16 species (Table B2). The condition factors for the white croaker, shiner perch, and speckled sanddab

were similar to or exceeded values reported earlier. Lower values were noted for the queenfish, white surfperch, and northern anchovy. It is important to note that the earlier data reported by Chamberlain (1973) and Stephens, et al. (1974) were calculated from fish taken throughout the harbor and therefore these data may not be comparable. The condition factor for the white croaker was highest near the outfalls and decreased towards the break-water.

Three types of external fish abnormalities were noted: exophthalmia, jaw malformation, and fin erosion. Four specimens of white croaker were observed with exophthalmia and jaw malformation, all from trawl 5. Fin erosion occurred predominantly in the white croaker and to a lesser extent in the queenfish and white surfperch. The greatest fin erosion in white croakers was present in the 90-150 mm size class at trawls 4 and 5, where 30 percent were diseased.

The dietary organisms of the fish collected are summarized in Table B4 according to trawl and species of fish. Food consisted primarily of polychaetes, crustaceans of all types, and molluscans which were predominantly bivalves. A correlation exists between organisms eaten by the fish and the organisms living in the area. Fish collected in trawls 1 and 3 fed primarily on *Capitella capitata*, a pollution indicator. Fish collected in trawls 4, 5, and 7 fed upon those animals characteristic of the semi-healthy zone; similarly, those fish collected in trawls 6, 8, and 9 fed upon typical healthy zone animals.

DISCUSSION

It could not be determined with any degree of certainty that the fish or the polychaetes were consuming organic waste material. Since the particulate organic waste material is amorphous, it would be difficult to identify by microscope examination. It is logical to assume that since most of these polychaetes feed either by engulfing material, like an earthworm, or filtering out the particles, they derive some of their nourishment from the wastes. The larger population of fish present just outside this area may in turn be the result of organic wastes passing up through the food web to the fish.

Brewer (pers. comm.) found fish near the outfalls with coagulated protein chunks and also pieces of fish muscle tissue in their guts. The fish tissue could be from bait or from predation; such material is not supposed to pass through the cannery screening devices. Similar tissue was found in the present study in fish from trawl 3 area.

LITERATURE CITED

- Allan Hancock Foundation. 1975. Environmental investigations and analyses for Los Angeles-Long Beach Harbors. A Report to the U.S. Army Corps of Engineers, Contract No. DAWCD 9-73-0112. 552 pp.
- Reish, D.J. 1959. An ecological study of pollution in Los Angeles-Long Beach Harbors, California. Allan Hancock Foundation Publ. Occasional Paper No. 22. 119 pp.

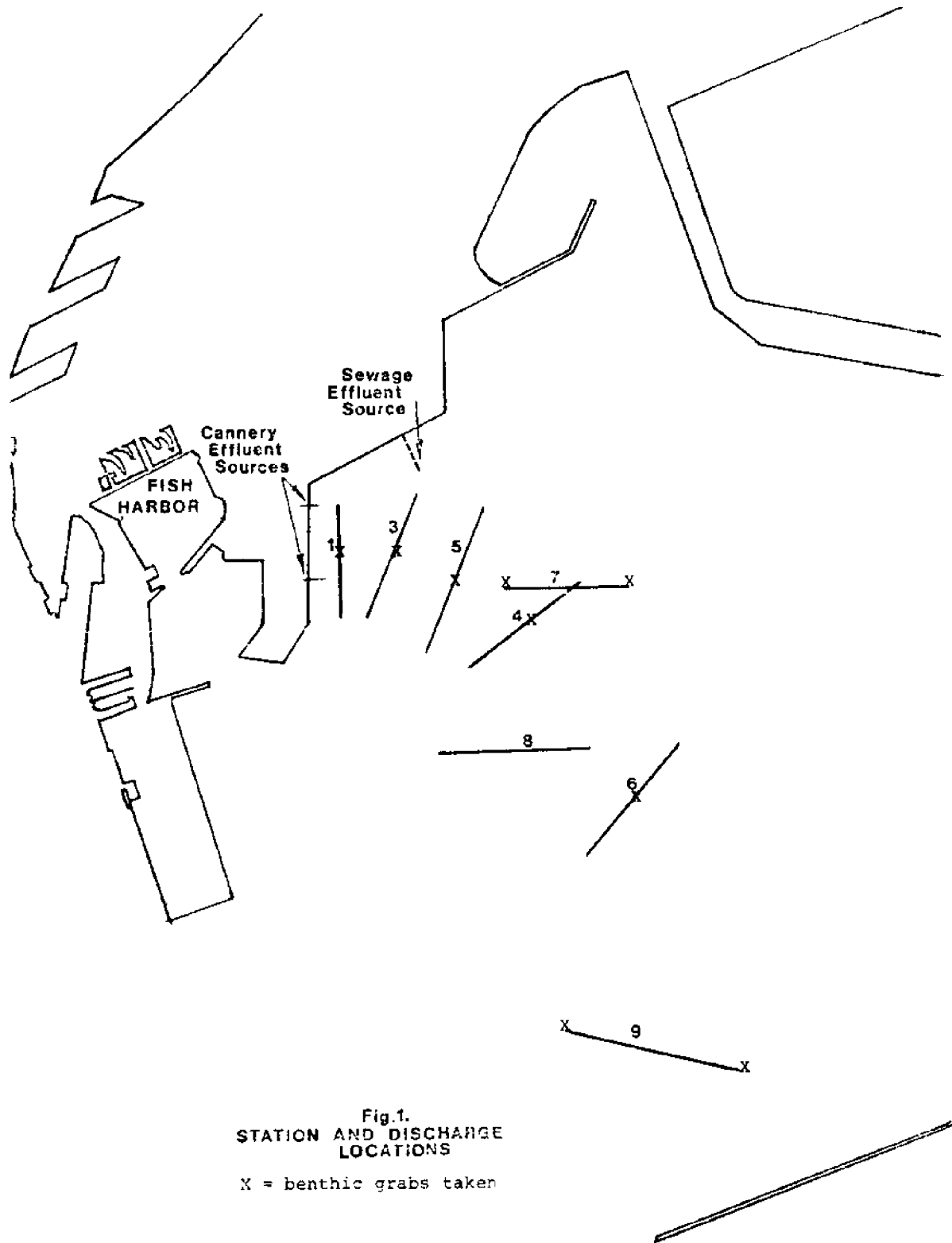

Fig.1.
STATION AND DISCHARGE
LOCATIONS

X = benthic grabs taken

Table 81. Spatial relationships of fishes in soft bottom communities *

Category	Description	Species
A	Obligate benthos	<i>Citharichthys stigmaeus</i> <i>Lepidogobius lepidus</i> <i>Paralichthys californicus</i> <i>Pleuronichthys decurrens</i> <i>Pleuronichthys verticalis</i> <i>Symphurus atricauda</i>
B	Facultative benthos	<i>Paralabrax maculatofasciatus</i> <i>Paralabrax nebulifer</i> <i>Porichthys myriaster</i> <i>Scorpaena guttata</i> <i>Sebastes miniatus</i> <i>Synodus lucioceps</i> <i>Synodus serranoides</i> (adults)
C	Benthos feeders	<i>Damalichthys vacca</i> <i>Embiotoca jacksoni</i> <i>Genyonemus lineatus</i> <i>Phanerodon furcatus</i> <i>Seriphus politus</i> ?
D	Water column fish	<i>Cymatogaster aggregata</i> <i>Sebastes goodei</i> <i>Sebastes saxicola</i> <i>Sebastes serranoides</i> (juveniles) <i>Seriphus politus</i> ?
E	Epipelagic fish	<i>Atherinops affinis</i> <i>Engraulis mordax</i>

* From Stephens, et. al., 1974.

Table B2. Species taken in trawls October 16, 1975 through March 4, 1976

Family	Species
Batrachoididae (Toadfishes)	<i>Porichthys myriaster</i> *
Bothidae (Left eye flounders)	<i>Citharichthys stigmaeus</i> * <i>Xystreurys liolepis</i>
Cynoglossidae (Tonguefish)	<i>Symphurus atricauda</i> *
Embiotocidae (Surfperches)	<i>Cymatogaster aggregata</i> * <i>Embiotoca jacksoni</i> * <i>Hyperprosopon argenteum</i> * <i>Phanerodon furcatus</i> *
Engraulidae (Anchovies)	<i>Anchoa compressa</i> * <i>Engraulis mordax</i> *
Myliobatidae (Eagle rays)	<i>Myliobatis californicus</i>
Platyrrhinidae (Thornbacks)	<i>Platyrrhinoidis triseriata</i>
Pleuronectidae (Right eye flounders)	<i>Hypsopsetta guttulata</i> * <i>Pleuronichthys verticalis</i> *
Sciaenidae (Croakers [Drums])	<i>Genyonemus lineatus</i> * <i>Seriphus politus</i> *
Scorpaenidae (Rockfishes)	<i>Scorpaena guttata</i> <i>Sebastes dalli</i> * <i>Sebastes miniatus</i> *
Syngnathidae (Pipefishes)	<i>Syngnathus leptorhynchus</i> *

* gut analysis performed

Table B3. Average fish condition factors, $K \times 10^{-5}$

Scientific Name	Common Name	May, 1972*	May, 1972-Oct., 1973**	Jan.-March, 1976
<i>Achoa compressa</i>	Deepbody anchovy			1.45
<i>Citharichthys stigmatæus</i>	Speckled sanddab	0.916	1.60	1.68
<i>Cymatogaster aggregata</i>	Shiner perch		2.53	2.70
<i>Embiotoca jacksoni</i>	Black perch			3.81
<i>Engraulis mordax</i>	Northern anchovy		0.88	0.70
<i>Genyonemus lineatus</i>	White croaker	1.27	2.16	2.17
<i>Hyperprosopeon argenteum</i>	Walleye surfperch			2.90
<i>Phanerodon furcatus</i>	White surfperch	1.11	2.54	2.41
<i>Porichthys myriaster</i>	Specklefin midshipman			1.36
<i>Sebastes dalli</i>	Calico rockfish		1.36	2.13
<i>Seriophilus politus</i>	Queenfish		2.20	1.42

* Chamberlain, 1973

** Stephens, et al., 1974

Table B4a. FISH GUT CONTENTS BY MAJOR FOOD GROUPS
(Percentage based on number of food items.)

January, 1976					
Station Fish Species	1	3	4	5	6
<i>Genyonemus lineatus</i> (White Croaker)		N=1 94.5 P 3.6 C	N=12 68.0 P 31.7 C	N=5 97.4 P 1.6 C 1.0 M	
<i>Seriphus politus</i> (Queen Fish)			N=12 68.7 P 8.5 C 22.3 CH 0.5 PI	N=5 93 P 7 C	
<i>Cymatogaster aggregata</i> (Shiner Surf Perch)	N=4 100 C	N=6 4.3 P 95.7 C	N=4 0.4 P 99.6 C		
<i>Embiotoca jacksoni</i> (Black Perch)				N=2 6 P 91 C 3 M	
<i>Hyperbrecoxon</i> (Walleye Surf Perch)			N=5 0.3 P 99.7 C		
<i>Phanerodon furcatus</i> (White Surf Perch)	N=4 16.4 P 83.6 C	N=10 85.3 P 14.7 C	N=3 2.0 P 99.8 C		
<i>Citharichthys stigmaeus</i> (Speckled Sanddab)			N=3 18.8 P 80.2 C 1.8 MISC		
<i>Symphurus atricauda</i> (Tongue Fish)	N=1 100 P				

LEGEND: P = Polychaetes N = Number of Fish Analyzed
C = Crustacea MISC = Miscellaneous Debris
M = Mollusca CH = Chaetognatha
PI = Pisces

Table B4b. FISH GUT CONTENTS BY MAJOR FOOD GROUPS

(Percentage based on number of food items)

March, 1976					
Fish Species \ Stations	1	3	4	5	6
<i>Genyonemus lineatus</i> (White Croaker)			N=18 4.0 P 94.4 C 1.6 NE	N=28 11.0 P 84.8 C 4.2 NE	
<i>Seriphus politus</i> (Queenfish)			N=11 29.4 P 70.6 C	N=11 13.6 P 84.2 C 0.1 NE 2.1 CH	
<i>Embiotoca jacksoni</i> (Black Perch)				N=5 10.4 P 89.4 C 0.2 M	
<i>Citharichthys stigmaeus</i> (Speckled Sanddab)	N=1 41.2 P 52.9 C 5.9 NE		N=1 25 P 75 C		N=4 20.4 P 77.8 C 1.9 NE
<i>Symphurus atricauda</i> (Tongue Fish)	N=1 40 P 60 C		N=3 80 C 20 M	N=5 75 C 25 M	

LEGEND: P = Polychaetes N = Number of Fish Analyzed
 C = Crustacea NE = Nematoda
 M = Mollusca CH = Chaetognatha

Table B4c. FISH GUT CONTENTS BY MAJOR FOOD GROUPS
(Percentage based on number of food items)

May, 1976					
Fish Species	Stations 1	3	4*	5*	6
<i>Phanerodon furcatus</i> (White Surf Perch)					N=5 6.0 P 84.7 C 7.3 M 2.0 E
<i>Citharichthys stigmaeus</i> (Speckled Sanddab)					N=10 26.6 P 70.3 C 1.9 M 0.6 PI.E 0.6 MISC
<i>Pleuronichthys verticalis</i> (Horny Head Turbot)					N=1 T-P T-C SI-25
<i>Symphurus atricauda</i> (Tongue Fish)					N=5 33.3 P 50.0 C 16.7 M
<i>Anchoa compressa</i> (Deep Body Anchovy)		N=1 5 P 95 C			
<i>Genyonemus lineatus</i> (White Croaker)	N=1 4.8 P 91.0 C T-M 14 MISC T-CN A1 - + A2 - + "Tissue" - +	N=22 5.2 P 86.8 C 0.1 M 8.0 MISC T-H T-E			N=5 48.3 P 48.3 C 3.4 M SI-+
<i>Cymatogaster aggregata</i> (Shiner Surf Perch)		N=7 100 C			
<i>Embiotoca jacksoni</i> (Black Perch)		N=5 8.6 P 90 C 0.8 M 0.6 MISC			

LEGEND: P = Polychaetes H = Hydroidea MISC = Misc. Debris
 C = Crustacea E = Ectoprocta PI.E = Pisces Eggs
 M = Mollusca SI = Mollusc Siphons T = Trace
 + = Present A1 = Alga, *Ulva* sp. A2 = Alga, *Enteromorpha* sp.
 CN = Cnidaria "Tissue" - amorphous mass of tissue
 N = Number of Fish Analyzed

Table B4d. FISH GUT CONTENTS BY MAJOR FOOD GROUPS
(Percentage based on number of food items)

October, 1976									
Fish Species	Stations	1	3	4	5	6	7	8	9
<i>Genyonemus lineatus</i> (White Croaker)							N=11 86.1 P 12.5 C 0.6 M 0.3 PH 0.5 MISC		N=4 87.0 P 12.6 C 0.4 M
<i>Seriphus politus</i> (Queenfish)									N=5 100 P
<i>Embiotoca jacksoni</i> (Black Perch)							N=2 1.0 F 1.0 P 93.2 C 4.8 M		N=3 7.1 P 83.4 C 9.5 M
<i>Phanerodon furcatus</i> (White Surf Perch)							N=5 25.2 P 67.4 C 6.5 M 0.9 MISC		N=2 13.3 P 80.0 C 6.7 M
<i>Pleuronichthys verticalis</i> (Horny Head Turbot)								N=3 33.3 P 33.3 M 33.3 P	N=7 82.5 P 17.5 M
<i>Symphurus atricauda</i> (Tongue Fish)									N=5 5.3 P 68.4 C 26.3 M

LEGEND: P = Polychaetes PI = Pisces N = Number fish analyzed
 C = Crustacea PH = Phoronida MISC = Miscellaneous Debris
 M = Mollusca F = Forams

Table B4e. FISH GUT CONTENTS BY MAJOR FOOD GROUPS
(by Percent Volume).

March, 1976						
Fish Species	Stations	1	3	4	5	6
<i>Genyonemus lineatus</i> (White Croaker)				N=18 45.0 P 44.7 C 1.7 NE 8.6 MISC	N=28 36.1 P 44.6 C 0.8 NE 0.9 M 0.4 O 17.2 MISC	
<i>Seriphus politus</i> (Queenfish)				N=11 67.8 P 32.2 C T-A	N=11 23.2 P 52.5 C 0.4 CH 20.3 MISC	
<i>Embiotoca jacksoni</i> (Black Perch)					N=5 19.0 H 21.7 P 15.9 C 10.6 M 22.8 MISC	
<i>Citharichthys stigmaeus</i> (Speckled Sand- dab)		N=1 31.1 P 6.3 C 62.5 MISC		N=1 83.3 P 16.7 C	N=5 60 P 40 C	

LEGEND: P = Polychaetes N = Number of Fish Analyzed
 C = Crustacea MISC = Miscellaneous Debris
 M = Mollusca NE = Nematoda
 A = Algae O = Oikopleura T = Trace
 H = Hydroidea CH = Chaetognatha

Table B4f. FISH GUT CONTENTS BY MAJOR FOOD GROUPS
(by Percent Volume).

May, 1976					
Fish Species	Stations 1	3	4	5	6
<i>Genyonemus lineatus</i> (White Croaker)	N=13 18.4 P 19.1 C 1.9 MISC 10.7 Al 49.9 FT	N=22 39.5 P 52.8 C 2.6 M 2.6 NE 2.6 MISC			N=5 1.5 P 69.8 C 11.7 M 17 MISC
<i>Cymatogaster aggregata</i> (Shiner Surf Perch)		N=7 100 C			
<i>Phanerodon furcatus</i> (White Surf Perch)					N=5 7.0 P 15.7 C 72.9 M 0.6 O 7.8 MISC
<i>Citharichthys stigmaeus</i> (Speckled Sanddab)					N=10 53 P 47 C T-PI T-MISC
<i>Pleuronichthys verticalis</i> (Horny Head Turbot)					N=1 83.5 SI 16.5 MISC

LEGEND: P = Polychaetes N = Number of Fish Analyzed
 C = Crustacea MISC = Miscellaneous Debris
 M = Mollusca NE = Nematoda
 Al = Alga, *Ulva* sp. FT = Fish Tissue
 T = Trace SI = Mollusc Siphons
 O = Ophiuroidea PI = Pisces

PART C.

- I. THE ENERGETIC ROLE OF AMINO ACID AND
PROTEIN METABOLISM IN THE
KELP BASS (*Paralabrax plathratus*) -

by

Karen Bever, Ph.D.

and

Arnold Dunn, Ph.D.

Department of Biological Sciences

- II. THE PROTEIN CONTENT OF SEAWATER IN SAMPLES
FROM OUTER LOS ANGELES HARBOR

by

Karen Bever, Ph.D.

- III. THE AMINO ACID CONTENT OF SEAWATER
IN SAMPLES FROM OUTER LOS ANGELES HARBOR

by

S.C. Chao, Ph.D.

Harbors Environmental Projects
University of Southern California
Los Angeles, California 90007

I. THE ENERGETIC ROLE OF AMINO ACID AND
PROTEIN METABOLISM IN THE
KELP BASS (*Paralabrax clathratus*)

by

Karen Bever, Ph.D. and Arnold Dunn, Ph.D.

INTRODUCTION

Most teleost fish, including the kelp bass (*Paralabrax clathratus*) are carnivorous, obtaining at least 70% of their caloric intake from protein. Since fish require carbohydrates for optimal muscle and nerve function, and since dietary sources of carbohydrate are quite limited, these organisms must synthesize glucose from the more readily available amino acid precursors obtained from the digestion of protein. This biochemical conversion of amino acids into glucose is termed "gluconeogenesis." Although any given amino acid can have a multiplicity of fates, gluconeogenesis is an important process which can give insight into an organism's ability to utilize amino acids as metabolic fuel. This past year we have initiated a series of experiments in intact, free-swimming kelp bass in order to measure glucose synthesis from three isotopically labelled amino acids (alanine-U-¹⁴C, aspartic acid-U-¹⁴C, and glutamic acid-U¹⁴C) and to monitor the turnover of these labelled amino acids in the blood of both fed and fasted fish. Kelp bass were used in these studies for two reasons: 1) surgical procedures for implanting the indwelling arterial cannula had already been established and 2) baseline studies of the metabolism of glucose in fed and fasted individuals had already been carried out. Data obtained from these individuals trapped at Catalina Island will serve as comparative material for further studies in the Los Angeles Harbor.

METHODS

Kelp bass (149-379 g.) were obtained by trapping in Big Fisherman's Cove, Catalina Island and maintained in 50 gallon aquaria with fresh, running seawater at ambient ocean temperatures. Squid were provided as a readily accepted food source. Resumption of feeding after capture was the criterion used to indicate adaptation to the new environment of the aquarium. A fasting state was obtained by withholding food for at least 20 days.

Anaesthesia is induced with MS 222 in seawater (1:10,000) and maintained by perfusing water containing the anaesthetic across the gills during surgery. The ventral aorta is exposed by a small incision in the membrane lining the gill chamber just over the heart. The cannula consists of 70 cm of polyethylene tubing (PE 60) attached to the bent shank of a 21 gauge hypodermic needle. The cannula is filled with heparinized saline, inserted into the ventral aorta (Figure C1-1) and subsequently cleared of any blood. The free end is heat-sealed and the cannula is anchored to the skin with silk sutures. Recovery from anaesthesia is effected by perfusing the gills with fresh seawater. The fish is then placed in an experimental tank for the duration of the experiment.

Tracer quantities of glucose-6-³H and either alanine-U-¹⁴C, aspartic acid-U-¹⁴C, or glutamic acid-U-¹⁴C are injected via the in-dwelling cannula at time zero. The cannula is then repeatedly flushed with saline to prevent isotope contamina-

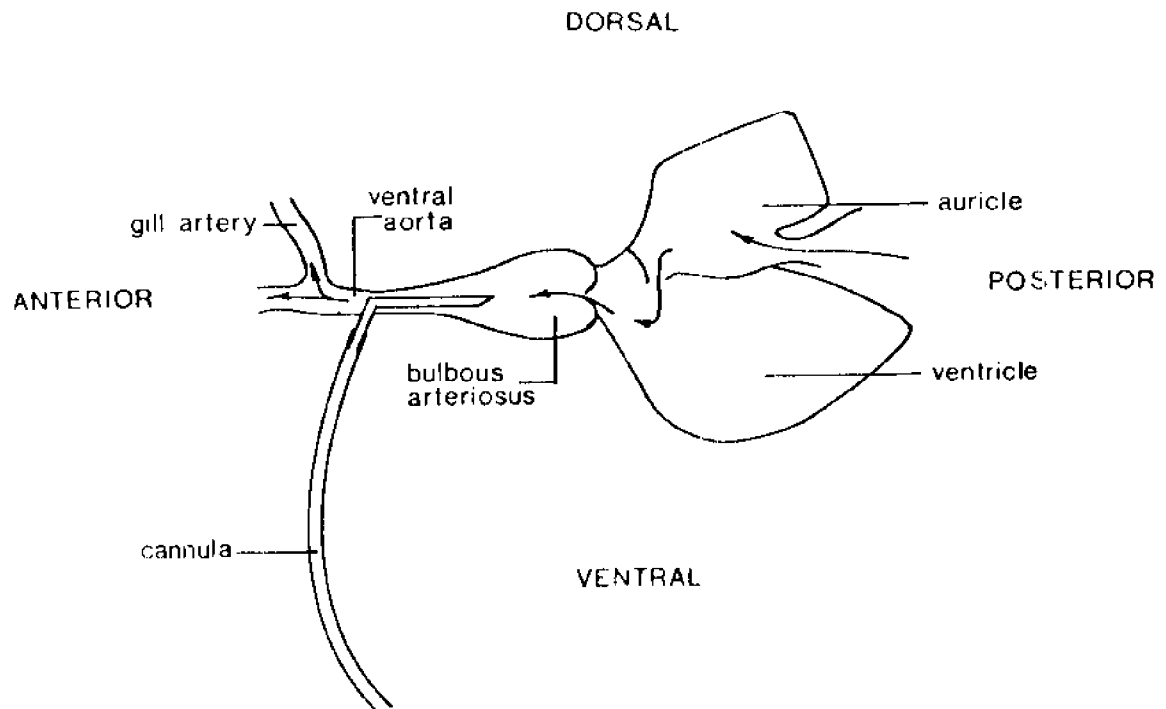

Figure CI-1. Anatomical location of the cannula in the kelp bass.
Arrows indicate the direction of blood flow.

tion of the early blood samples. Serial blood samples are drawn at appropriate intervals after isotope administration. Every attempt was made to avoid disturbing the animal.

Plasma glucose is assayed by the hexokinase procedures of Bergmeyer (1963) after a perchloric acid precipitation of plasma proteins. The remaining supernatant is applied to ion exchange columns (Dowex 50 (H^+) and Dowex 1 (acetate $^-$)) which are stacked in series according to the methods of Katz et al. (in press). Glucose is eluted with water and the specific activity (counts per minute/mg glucose) is determined. The columns are then separated. The amino acids are eluted from the Dowex 50 column with 0.1M phosphate buffer, pH 8.0 and assayed for radioactivity.

RESULTS

DISAPPEARANCE OF THE AMINO ACIDS

Labelled alanine, glutamic acid and aspartic acid all disappear rapidly from the plasma of fed and fasted fish. Because there is no significant difference between these two nutritional groups with respect to the amino acid disappearance rates, data is grouped together in Table CI-1 . By 15 minutes, nearly 90% of the administered glutamic and aspartic acids have been removed from the plasma. Thirty minutes are required for comparable quantities of alanine to disappear. By 60 minutes, effectively all of the administered isotopic amino acids are gone. In rats, only 7% of the alanine dose remains at 15 minutes; however, these mammals have a much higher metabolic rate as well as a shorter circulation time

Table CI-1. Disappearance of radioactive amino acids from the plasma of kelp bass.

	% of the dose remaining		
	<u>15 min.</u>	<u>30 min.</u>	<u>60 min.</u>
Alanine	56±15	13±3	8±4
Glutamic acid	12±4	6±2	3±1
Aspartic acid	13±1	8±1	4±0

Values are the mean±standard error of the mean.

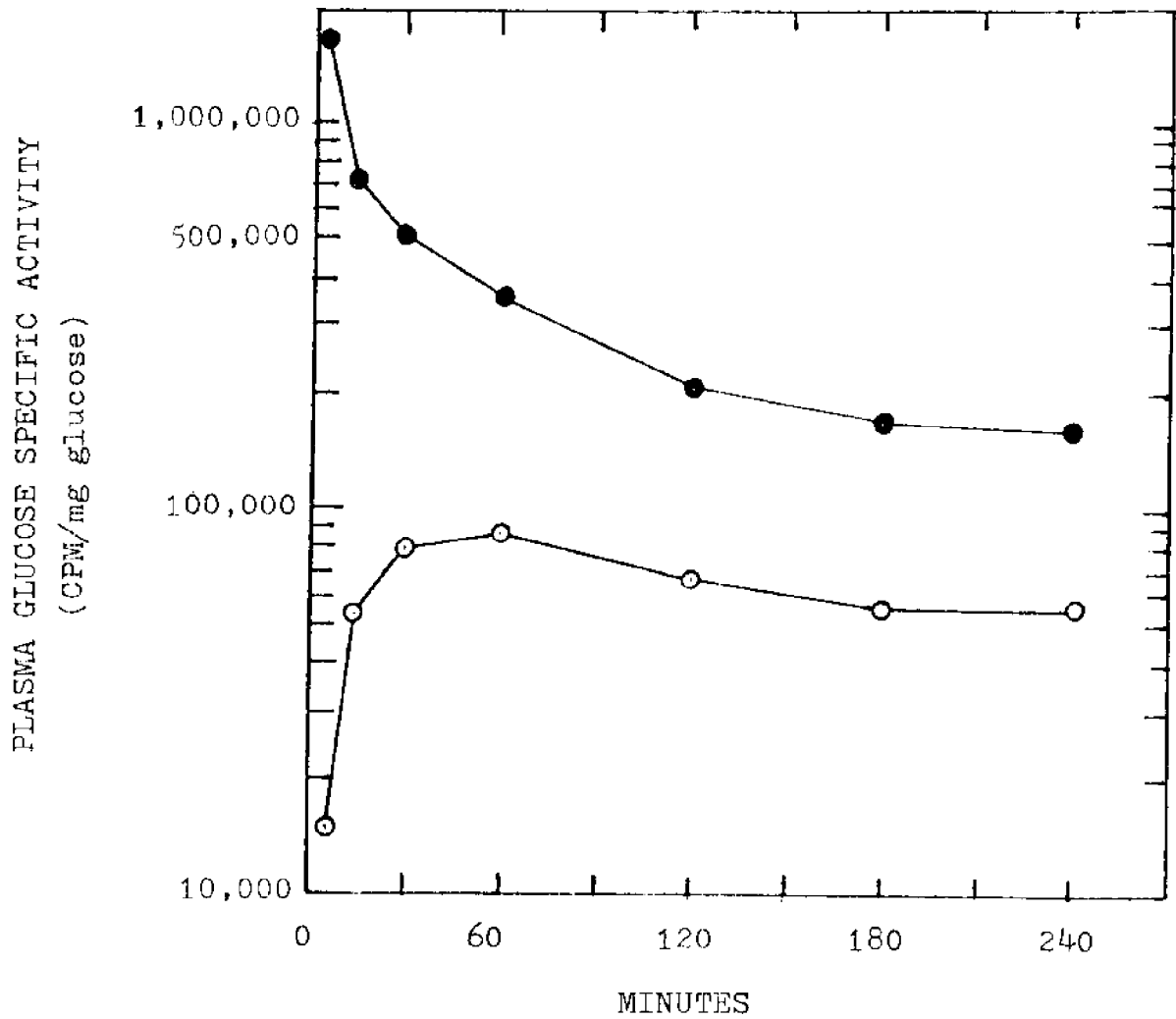

Figure CI-2. Incorporation of ^{14}C carbon of glutamic acid into plasma glucose. ●, glucose-6- ^3H ; ○, glucose- ^{14}C appearing from glutamic acid-U- ^{14}C . Experimental animal was fasted 79 days.

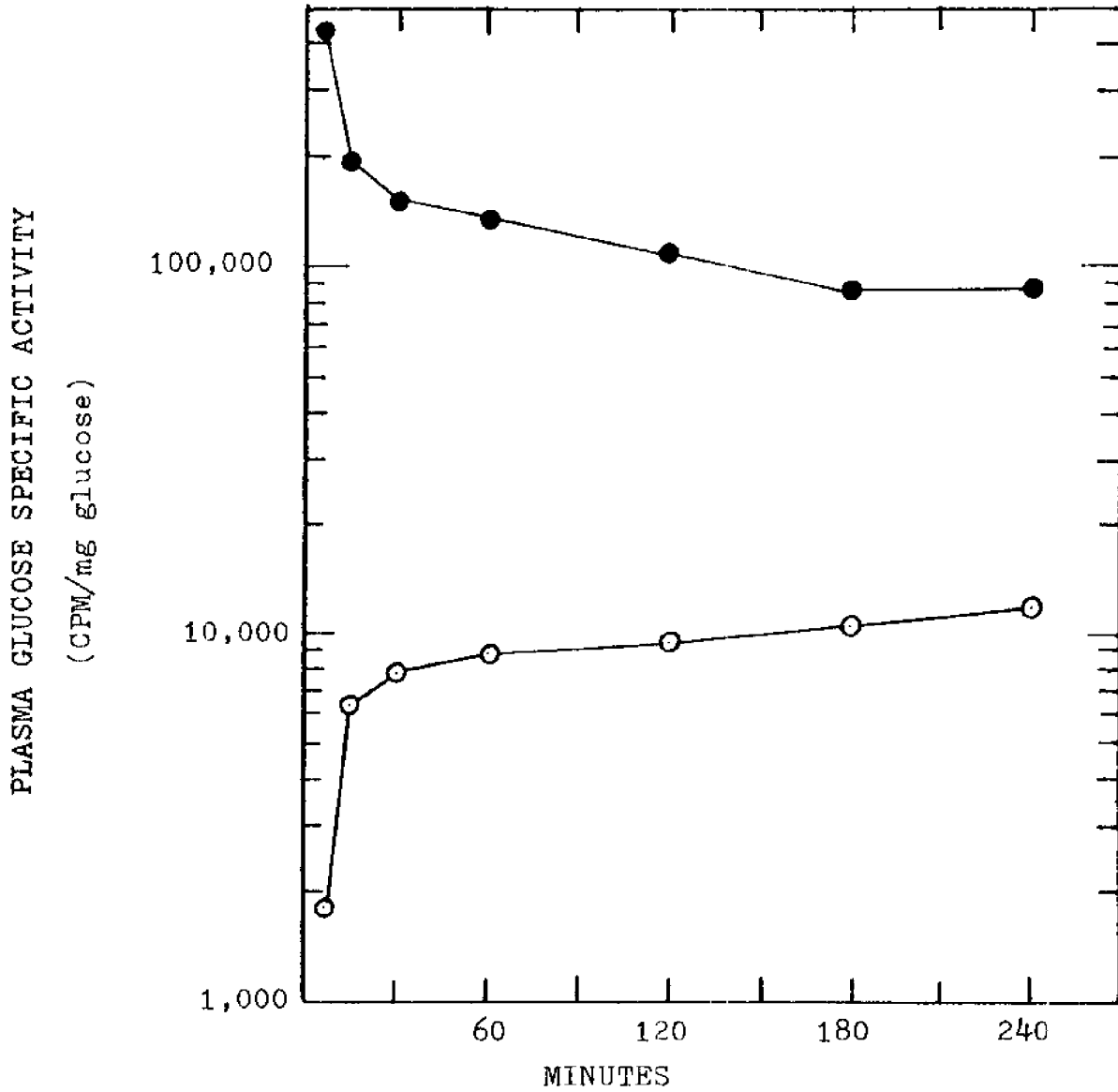

Figure CI-3. Incorporation of ^{14}C carbon of alanine into plasma glucose. ● , glucose-6- ^3H ; ○ , glucose- ^{14}C appearing from alanine-U- ^{14}C . Experimental animal was fasted 79 days.

(Prosser, 1973) when compared with kelp bass (Bever et al., submitted). When these differences are taken into consideration, the removal rates of all three amino acids from the plasma of these fish are comparable to or greater than those in mammals.

KINETICS OF INCORPORATION

Figure CI-2 shows a representative example of the appearance of glutamic acid carbon into plasma glucose of a fish fasted 79 days. For comparison, the simultaneous turnover of glucose-6-³H in the same experimental animal is presented. By 60 minutes, the specific activity curve of the ¹⁴C-glucose derived from glutamic acid parallels that of the ³H-glucose, suggesting that no further incorporation of radioactive carbon occurs during the remainder of the experiment. Not unexpectedly, all of the glutamic acid-U-¹⁴C has disappeared from the plasma.

Figure CI-3 shows a similar experiment in another fish fasted for 79 days and injected with alanine-U-¹⁴C, glucose-6-³H. Although incorporation of the alanine carbon into plasma glucose is rapid during the first 60 minutes, a continual slow input of ¹⁴C occurs for the duration of the experiment. The changes in the specific activity of the ¹⁴C- and ³H-glucose are not parallel as they were in Figure CI-2. The alanine dose is somewhat slower in disappearing, requiring 120 to 180 minutes before essentially all of the radioactivity has been removed from the plasma. Although both alanine and glutamic acid are gluconeogenic, the different kinetic behavior during

fasting may reflect differences in the pool sizes of the two amino acids (i.e., the total amount of available alanine and glutamic acid in the plasma of the experimental animals). Thus more unlabelled alanine (a larger pool) would dilute the administered radioactive alanine thereby decreasing the apparent conversion of radioactive carbon into the glucose skeleton. We anticipate measuring the plasma amino acid levels in fed and fasted fish during the coming year.

TOTAL INCORPORATION

Peak incorporation of amino acid carbon into plasma glucose in kelp bass is more extensive than that found in rats under similar circumstances for all three amino acids examined (Table CI-2). By 30 minutes as much as 1.6% of the ^{14}C -aspartic acid dose is incorporated per mg of plasma glucose in fed fish. The least amount incorporated was found with glutamic acid (0.2%). For the rat, the maximal synthesis of glucose from amino acid carbon occurred at 5 minutes with aspartic acid (0.3%). The least conversion to plasma glucose occurred with glutamic acid (0.2%). Thirty and 60 minute values for the rat are shown in Table CI-2 for comparative purposes. Due to the temperature dependence of biochemical reactions, most metabolic events in warm-blooded mammals are quite rapid compared with those in cold-blooded fish. In contrast, amino acid gluconeogenesis in kelp bass is a process which occurs relatively rapidly and far more efficiently than that in the rat.

Table CI-2. Incorporation of amino acid carbon into plasma glucose in rats and kelp bass.

		<u>fed fish</u>	<u>fasted fish</u>		<u>rat</u> *
Days without food		2-14	20-33	79	1
Alanine	30 min.	1.3±0.3	2.5±0.8	0.3±0.0	0.1
	60 min.	0.7±0.1	1.7±0.5	0.3±0.1	0.1
Glutamic acid	30 min.	0.2±0.1	-----	2.2	0.2
	60 min.	0.3±0.2	-----	2.3	0.1
Aspartic acid	30 min.	1.6	-----	0.7	0.2
	60 min.	1.3	-----	0.7	0.1

Values are the mean ± standard error of the mean. When only a single number appears, it is the mean of two experiments.

* Data taken from Dunn, et al. (5).

With prolonged fasting (20-33 days), the conversion of alanine carbon to glucose tends to increase (1.3% to 2.5%) as would be expected if protein is the major source of glucose carbon both in the diet and as a depot of stored energy. After extensive fasting (79 days) gluconeogenesis from alanine and aspartic acid falls. Only that from glutamic acid increases. Rather remarkable quantities of the administered ^{14}C -alanine and ^{14}C -aspartic acid are still being incorporated even after 79 days without food. This data is consistent with adaptation to a protein based metabolism as would be the case with carnivores.

DISCUSSION

Previous work by D.W. Chamberlain (1975, 1976) suggested that fish are capable of removing amino acids from seawater and incorporating them into their body mass. A necessary extension of this work is the investigation of the role these amino acids might play in the nutrition of marine fish. Since glucose is a major source of energy for nerve and muscle function, efficient conversion of amino acid carbon into plasma glucose would suggest that protein and amino acids are necessary for maintenance and growth of marine fish, particularly in light of the lack of a dietary source of carbohydrate (glucose). Using radioactive amino acids (alanine, glutamic acid, and aspartic acid) we undertook an estimation of the contribution of amino acids to glucose production in intact, free-swimming kelp bass, *Paralabrax clathratus*, a popular sport fish found in the waters off southern California.

Not only was there a rapid uptake of all three amino acids from the plasma of these fish, there was an equally rapid and efficient conversion of the ^{14}C dose into plasma glucose. To emphasize the importance of this process in fish, a comparison with that in a mammal is instructive. While the plasma glucose turnover in rats is approximately 22 times that in the kelp bass (Bever et al., submitted), the maximum incorporation of ^{14}C carbon into glucose with labelled alanine and aspartic acid was 1/13 and 1/5 that found in kelp bass. Glutamic acid was equally good as a precursor in both fish and rats, although fasting the fish for 79 days considerably elevated gluconeogenesis from this amino acid.

There is a considerable difference in the diet of kelp bass and the laboratory rat. The former is a carnivore, the latter, an omnivore. Although rats normally consume a large proportion of their caloric intake as carbohydrate, if their diet is modified to one high in protein, gluconeogenesis is stimulated (Eisenstein et al., 1974). For mammalian carnivores such as the dolphin (*Tursiops truncatus*) (Patton, 1975), increased emphasis is placed upon amino acid metabolism. Similar results were seen in comparative studies of the vulture (carrion eater) and granivorous domestic chicken (Migliorini, 1973).

We believe that marine fish are well adapted to a proteinaceous diet and may in fact gather in locations rich in this type of food. Certainly comparative studies must be carried out on fish found near the cannery outfalls in t'e

Los Angeles Harbor to determine if these animals are equal to or greater than the control fish from Catalina Island in their ability to utilize protein and amino acids found in the effluent from these processing plants. This work is being continued under the NSC-Sea Grant Program in 1976-1977.

Preliminary Note:

Direct Uptake of Amino Acids by the Gut of
the Kelp Bass, *Paralabrax clathratus*

by

Karen Bever and Arnold Dunn

Work in our laboratory previously reported in this volume (Part C.I.) has demonstrated an enhanced ability of intact, free swimming kelp bass (*Paralabrax clathratus*) to convert amino acid carbon to glucose, a major energy source for metabolic activity. This capacity for rapid amino acid gluconeogenesis is indicative of a metabolism which emphasizes protein as metabolic fuel. Logically, then, such fish ought to be able to utilize not only discrete, ingested protein (invertebrate and vertebrate prey items) but also amino acids and protein contained in water swallowed during normal activity. The latter process would only provide a nutritional source when ambient water was heavily enriched in protein and amino acids, such as occurs in the Fish Harbor area of the Los Angeles Harbor (Part C.I.). To test the ability of kelp bass to accumulate ingested amino acids in the circulation, a polyethelene cannula (PE 60) was implanted in the ventral aorta as previously described for monitoring radioactivity (Fig. CI-1). In addition, a stomach tube consisting of PE 60 tubing was placed in the stomach of the anesthetized fish. The tube exited through a PE 200 sleeve implanted in the membrane between the premaxillary and the skull. This was to minimize interference of the stomach tube with respiratory movements as

Harbors Environmental Projects University of Southern California

would occur if the tube exited from the mouth. On the day after surgery, 5 uCi of mixed amino acids were injected into the stomach via the tubing and the plasma was sampled at regular intervals for 19 hours. The plasma sample was deproteinized with perchloric acid, neutralized, and an aliquot was counted in a Beckman LS233 liquid scintillation counter.

Although the results are only preliminary in that only one fish was used in the experiment, by five minutes an estimated 40% of the administered dose appeared in the plasma. At 30 minutes 42% could be detected. From 30 minutes, radioactivity in the plasma declined until only 6% of the dose remained 19 hours post-isotope injection. Many more experiments of this kind are necessary to substantiate this data, however, due to the rapid (within 5 minutes) appearance and the magnitude of the radioactivity detected in the circulation, we feel reasonably certain that carnivorous fishes, living in water enriched in suspended protein and amino acids, would be able to make efficient use of these nutrients, providing sufficient quantities of water were swallowed. It is likely that obtaining proteins and amino acids by this means would provide a supplementary source of nutrition in large fish rather than the sole dietary input. We have demonstrated, however, that the potential exists for efficient absorption by the gut, and once the amino acid appears in the plasma, rapid conversion to energetically important intermediates such as glucose will take place. Yet to be investigated is the possible uptake of amino acids by the gills.

II. THE PROTEIN CONTENT OF SEAWATER IN SAMPLES
FROM THE LOS ANGELES HARBOR

by Karen Bever

INTRODUCTION

The fish cannery wastes in the Los Angeles Harbor have been under investigation during recent years as a potential source of organic nutrients for both vertebrate and invertebrate life in the harbor waters. Evidence for the enhancement of the quality of the water by effluent wastes can be inferred from the work of Stephens, et al. (1974) who found high densities of fish in the region adjacent to the cannery outfalls. Investigations by Chamberlain (1975) suggested that cannery effluent could, at least temporarily, support a small harbor goby (*Clevelandia ios*). Furthermore, this goby accumulated added ^{14}C -glutamic acid from the sea water. Other investigators have demonstrated direct uptake of amino acids by invertebrates (Wright et al., 1975; Southward and Southward, 1972) and phytoplankton (North, 1975). Larger protein molecules could be removed as particulates depending upon the size of the particles and the rate of filtration by the consumer (Owen, 1966; Prosser, 1973).

That the fish cannery effluents would supply biologically useful organic compounds is clear since the released waste is primarily of biological origin. Determination of the actual levels of protein in the effluents and in harbor water is the subject of this study. Furthermore, comparisons with primary waste from

the Terminal Island Treatment Plant and with secondary wastes from the Hyperion Treatment Plant were made to quantify the effect such treatment would have on both the cannery and TITP outfalls with respect to the available protein in the discharge water.

METHODS

Water samples were collected from eleven stations in the Los Angeles Harbor area (Fig.CII-1). At each station, both surface water and water from approximately one meter above the bottom was taken, frozen as rapidly as possible, and transported to the University of Southern California for analysis of total protein according to the methods of Schaffner and Weissmann (1975). A brief outline of the method follows.

One ml of the thawed, well mixed sea water sample is placed in an 11 x 75mm test tube. To this is added 0.1 ml 1M Tris-HCl pH 7.5 containing 1% sodium dodecyl sulfate and 0.4 ml 60% trichloroacetic acid (TCA). After mixing, the entire assay volume is filtered through a 0.45 micron Millipore filter. The assay tube is rinsed with 6% TCA and filtered through the same location as the initial volume. Approximately eleven samples were prepared from bovine serum albumin, fraction V (5-20ug BSA/assay).

The filter disc carrying the precipitated protein is then placed in 0.1% amidoschwartz dye prepared in methanol:glacial acetic acid:distilled water (45:10:45), washed in water, and destained in three successive washes of methanol:glacial acetic

acetic acid:distilled water (90:2:8). After a final wash in distilled water, the disc is then dried. Stained areas are removed with a cork borer, placed in an 11 x 75mm test tube and eluted with 1.2 ml of eluant (25mM NaOH, 0.5mM EDTA in 50% ethanol). After ten minutes, the absorbance is read at 630 nm in a Beckman DB spectrophotometer using a semi-micro cell.

Assays were run in duplicate with variation between duplicates less than 15%. If the standard BSA protein solution is diluted directly in the assay tube with natural sea water, the absorbance obtained is equivalent to that measured when the diluant is distilled water. Since BSA will clump and precipitate if left in sea water for any period of time, standards were routinely prepared in distilled water for ease in handling and storage.

RESULTS AND DISCUSSION

Since the amidoschwartz protein assay measures precipitated protein, it can be used effectively to monitor total protein (both dissolved and particulate fractions) in harbor water as long as a homogeneous suspension is obtained. Agreement of duplicate assays (within 15% for both standards and unknowns) indicates that this uniformity can be attained by careful mixing of the thawed sample prior to removing each aliquote for assay. In order to determine the fraction of protein which is in particulate form, samples from several stations were analyzed before and after filtration through a 0.45 micron Millipore filter. As can be seen in table CII-1, between 78 and 87% of the analyzable

protein is removed by filtration. There was no difference upon filtration for CTP stations 1 and 4. The former (station 1) is located outside of the breakwater and provides a background level for comparison with harbor stations. CTP station 4 is a short distance from the cannery and sewage outfalls (Fig. CII-1) and, in this instance, no difference from the background was noted, not was there any apparent precipitated protein in the water sample. Since the majority of the protein which would be available to the harbor biota is lost when the water is filtered, the remainder of the analyses were carried out on unfiltered samples. Furthermore, as other investigators in this project utilized unfiltered water in their bioassays, quantitation of total protein values was desirable.

Not unexpectedly, the protein content of the cannery effluents far exceeds that at any of the other sampled locations (table CII-2). Day-to-day variability was high (28.2-84.2 mg/L, Starkist; 26.9-53.4 mg/L, Main Street Station) depending upon the level of activity in the canneries. Similar variation was seen in the TITP outfall area (3.8-18.4 mg/L). These latter levels, elevated over the background by 5 to 23 times, may in fact result from mixing with cannery protein. Given the large amount released by the canneries and the circulation patterns in this area of the harbor (Soule and Oguri, 1972, 1973), any contribution of protein by TITP might be obscured. Since no effluent was collected inside the treatment plant, it is difficult to separate the contribution of the TITP outfall from

Table CII-1: Dissolved and particulate fractions in harbor sea water. Values are the average of duplicate samples and are expressed in mg protein/L. "Filtrate" is prepared by passing the sample through a 0.45 micron filter.

Station	Total protein	Filtrate	% particulate
1	0.5	0.5	0
4	0.5	0.6	0
5	39.9	8.1	78
6	27.4	4.5	84
7	12.2	1.6	87

cannery discharges in elevating surface water protein levels. According to the dye studies of Foxworthy (1973), however, maximal dilution of the cannery waste should occur prior to the treatment plant outfall. The calculated dilution would reduce the levels of cannery-generated protein measured in this investigation to near background levels by the time it reaches the sewer outfall.

Secondary-treated effluent taken from the Hyperion treatment plant is significantly lower in protein (1.4-1.8 mg/L) than water taken at the TITP boil. This type of treatment will effectively remove the potentially important nutrient source from the discharged water of the canneries if it is processed through TITP.

Although the pattern of distribution of the cannery protein depends upon surface currents and would be expected to vary accordingly from day to day, it appears as if most of the protein is confined to the immediate area adjacent to the three outfalls (Table CII-2, Fig. CII-1). Without more widespread sampling, the extent of direct influence of the canneries and TITP upon more distant regions of the harbor cannot be determined. Certainly at CPT stations 2 and 3, protein levels are approximately equal to background values for the days sampled during this study.

Up to this point, the discussion has been concerned with the surface waters. At depths one meter above the bottom, protein concentrations are reduced significantly (Table CII-2). At

Table CII-2: A comparison of unfiltered sea water samples from the eleven stations in the Los Angeles Harbor. "Surface" refers to samples taken at the surface; "Bottom" refers to those taken one meter above the sediment. Values represent the average of duplicate assays and are expressed in mg protein/L.

Date collected	Surface				Bottom		
	6/17	6/23	7/8	7/22	8/8	6/17	7/22
Station							
1	----	----	0.5	1.2	0.6	1.2	1.2
2	1.7	----	----	1.8	1.2	1.8	1.3
3	1.8	----	----	1.8	4.7	----	1.1
4	0.8	----	0.5	10.7	8.5	0.6	1.9
5	28.2	42.3	39.9	29.6	84.2	0.0	1.9
6	26.9	35.5	27.4	41.7	53.4	10.6	5.1
7	3.8	18.4	12.2	6.2	12.3	0.7	0.9
8	----	----	----	2.8	0.6	2.9	1.0
9	0.1	----	----	16.7	17.2	0.2	2.7
10	2.4	----	----	11.9	7.1	1.5	0.9
11	0.5	----	----	9.0	12.2	0.7	0.7

only one station (station 6) was the level consistently greater than four times that at the background station. This was, however, the shallowest station sampled (fig. CII-1). It appears as if the surface water is far richer in this potential nutrient than is the water near the bottom of the harbor. This supports previous observations of Soule and Oguri (1973) concerning the surface distribution of the cannery plume. Further sampling at regular intervals between the surface and the sediment might give a more definitive pattern of the vertical distribution of the effluents; it appears as if organisms found in the surface waters might be expected to derive more benefit from the available protein than would the benthic fauna. Nevertheless, the faunal patterns determined in a benthic study of the same area showed that the richest biomass occurred along the periphery of the CPT stations, between 2 and 3, and near 11.

The amount of useful protein obtained from the harbor water would depend upon many factors. First, the filtration rate and the efficiency of extraction of the nutrient containing sea water by a given organism would be a major determinant. At the highest concentrations of protein measured (84.2 mg/L) an organism would be required to filter 12 liters of water to obtain one gram of protein if that individual was 100% efficient at extracting the protein from the sea water. At the maximum levels found near the bottom, one gram could be extracted from 94 liters. These volumes are not necessarily out of the range of many invertebrates. Adult oysters are capable of filtering 4-15 liters/hour and

Mytilus edulis, 0.2-2 liters/hour (Owen, 1966). Of course, reported rates of filtration are a function of body size as well as of species, ambient temperature, and the previous nutrient history of the animal (fed, fasted, starved). Vertebrates would have to obtain the protein from ingested water. Secondly, the quality of the protein--that is, how much of the available protein can be digested-- is important. As much as 97% of the protein content in the natural diet of trout can be digested, while only 70% of that in soybean meal is utilized (Phillips, 1969). The assumption is made, in the case of the cannery effluents, that the majority of the available protein is of biological origin and is fish protein. Finally, the specific nutritional requirements, the age or size of the organism, and the feeding adaptations of the individual species would determine the degree to which dissolved and particulate protein could be used. While the amount of protein might not be the sole source of energy for growth and development of populations of organisms found in the areas adjacent to the outfalls, it should serve at least as a supplementary nutrient source for a variety of species. Secondary treatment of the cannery effluents will certainly remove the majority of this potentially useful biological nutrient from the harbor.

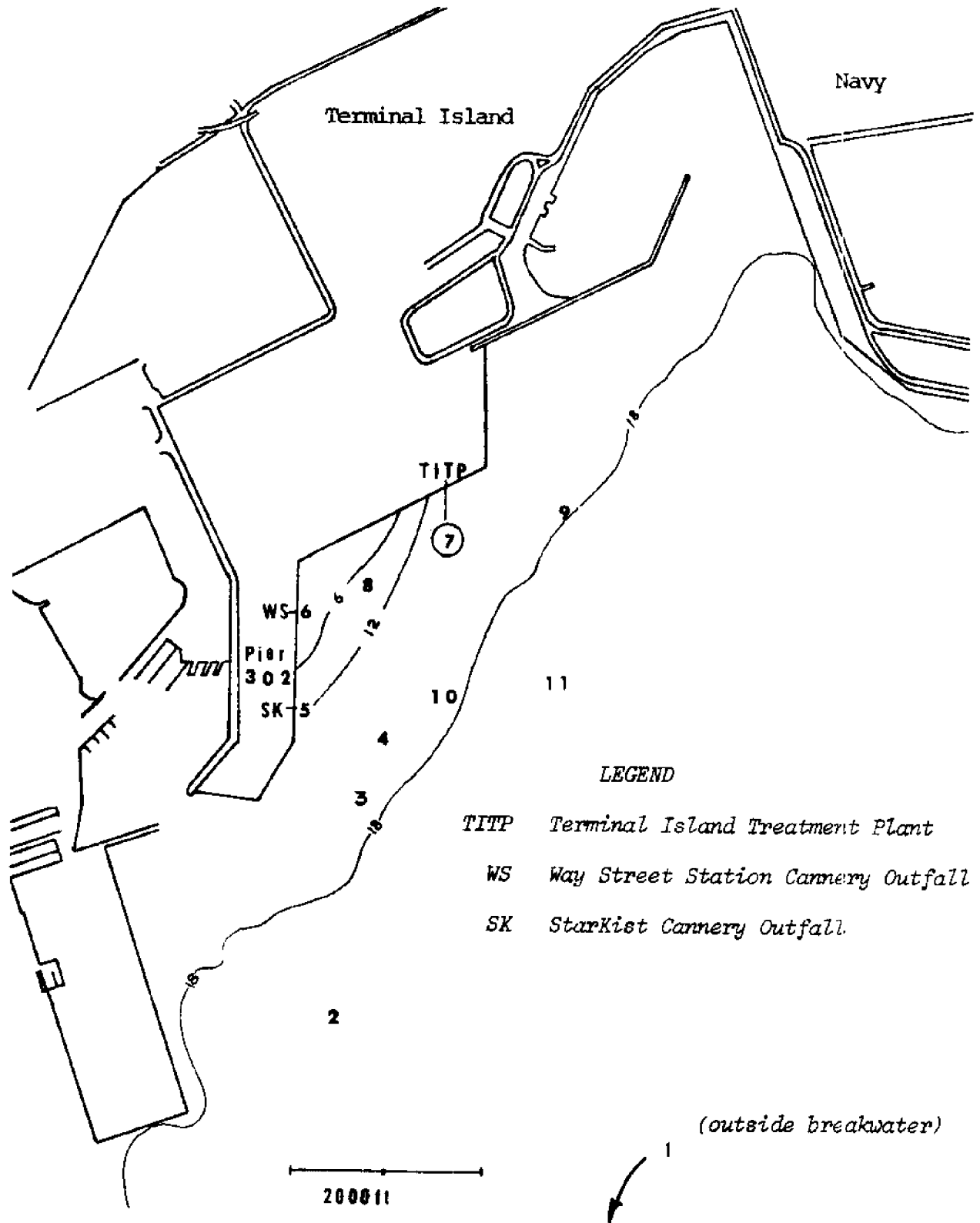

Figure D 1 Cannery/Treatment Plant (CTP), Special Stations, 1976

Fig. 1: Station locations in the area of the three outfalls.

Station 5 is Starkist effluent; station 6 is Way Street

Station cannery effluent and station 7 is the TITP outfall.

Bottom depths are indicated.

LITERATURE CITED

- Bergmeyer, H.U. 1963. Methods of enzymatic analysis. Academic Press, New York and London. pp. 117-123.
- Bever, K., M. Chenoweth, and A. Dunn. Submitted for publication. *In vivo* estimation of glucose production and uptake in fed and fasted kelp bass (*Paralabrax clathratus*) using 6-³H and 6-¹⁴C glucose.
- Chamberlain, D.W. 1976. Effects of Los Angeles Harbor sediment elutriate on the California killifish (*Fundulus parvipinnus*) and white croaker, *Genyonemus lineatus*. In Marine Studies of San Pedro Bay, Calif. Part 11, pp. 338-48.
- Chamberlain, D. 1975. The role of fish cannery waste in the ecosystem. In Marine Studies of San Pedro Bay, California, Part VIII, Soule & Oguri, eds. Allan Hancock Foundation Publication USC-SG-1-22.
- Dunn, A., M. Chenoweth, and J.G. Heminton. 1971. The relationship of adrenal glucocorticoids to transaminase activity and gluconeogenesis in the intact rat. Biochem. Biophys. Acta 237: 192-202.
- Eisenstein, A., I. Strack and A. Steiner. 1974. Glucagon stimulation of hepatic gluconeogenesis in rats fed a high protein, carbohydrate free diet. Metabolism 23:15-23.
- Katz, J., A. Golden, A. Dunn, and M. Chenoweth. In press. Estimation of glucose turnover in rats *in vivo* with tritium labelled glucoses. Metabolism.
- Migliorini, R.H., D. Linder, J. Moura and J. Veiga. 1973. Gluconeogenesis in a carnivorous bird (black vulture). Am. J. Physiol. 225:1389-1392.
- North, B. 1975. Primary amines in California coastal waters: utilization by phytoplankton. Limnol. Ocean. 20:20-27.
- Owen, G. 1966. Feeding in Physiology of Mollusca. Wilbur and Yonge, eds. Academic Press, N.Y. pp. 29-42.
- Patton, G.S. 1975. Metabolic studies on marine mammals: characterization of alpha- and beta-cell function. Dissertation, University of Southern California.
- Phillips, A. 1969. Nutrition, digestion, and energy utilization in Fish Physiology. Hoar and Randall, eds. Academic Press, N.Y. pp. 391-432.

- Prosser, C.L. 1973. Comparative Animal Physiology. W.B. Saunders Co., Philadelphia. pp. 182-184.
- Schaffner, W. and C. Weissmann. 1973. A rapid, sensitive and specific method for the determination of protein in dilute solution. Anal. Biochem. 56: 502-514.
- Soule, D. and M. Oguri. 1972. Circulation patterns in Los Angeles-Long Beach Harbor: Drogue study atlas and data report in Marine Studies of San Pedro Bay, California Part 1. Soule and Oguri, eds. Allan Hancock Foundation Publication USC-SG-6-72.
- Soule, D. and M. Oguri. 1973. Preliminary investigations of the role of cannery wastes in the Los Angeles Harbor: an introduction in Marine Studies of San Pedro Bay, California. Part II. Soule and Oguri, eds. Allan Hancock Foundation Publication USC-SG-2-73.
- Southward, A. and E. Southward. 1972. Observations on the role of dissolved organic compounds in the nutrition of benthic invertebrates. Sarsia 48: 61-70.
- Stephens, J., D. Terry, M. Allen. 1974. Abundance, distribution, seasonality, and productivity of the fish populations in Los Angeles Harbor 1972-1973 in Marine Studies of San Pedro Bay, California. Part IV. Soule and Oguri, eds. Allan Hancock Foundation Publication USC-SG-2-74: 1-42.
- Wright, W., T. Johnson, and J. Crowe. 1975. Transport of amino acids by isolated gills of the mussel, *Mytilus californianus*. J. Exp. Biol. 62: 313-325.

III. THE AMINO ACID CONTENT OF SEAWATER
IN SAMPLES FROM OUTER LOS ANGELES HARBOR

by S. C. Chao

INTRODUCTION

The presence of amino acids in cannery wastes stem from the release of free amino acids and the lysing of proteins during fish processing, or of subsequent microbial action. While analysis of total protein can be accomplished by rather direct methods, techniques for identifying amino acids in the relatively low quantities present in saline receiving waters present difficulties. The importance of amino acids in receiving waters has not been well investigated, but uptake into the food chain has been indicated for a variety of invertebrates, vertebrates and phytoplankton (Bever, Appendix C 2).

The procedures were divided into three major steps. First, the amino acids were isolated from seawater samples. Second, the amino acids were converted to a derivative which absorbs strongly in the ultraviolet (UV) region. Third, the amino acids derivatives were analyzed qualitatively and quantitatively by high pressure liquid chromatography (HPLC).

ISOLATION OF AMINO ACIDS FROM SEAWATER

Approximately two liters of seawater samples were collected from each of the designated stations in the Los Angeles Harbor. These samples were frozen as soon as possible to prevent any

biological activities. Prior to analysis the solution was thawed; and approximately ten milliliters of chloroform was added to prevent further biological activities during the isolation process.

Since the seawater samples from the Los Angeles Harbor contained large quantities of solid matter, the solutions were vacuum filtered through Whatman number 1 filter paper. Then, the filtered solutions were made alkaline to pH 9.5 by adding solid NaOH pellets and 1 N NaOH solution. Since seawater contains many metallic cations (Ca^{2+} , Mg^{2+} , etc.), insoluble hydroxides were formed upon addition of NaOH. These precipitates had to be filtered again. However, these filtrations were carried out with Millipore filtering apparatus and 0.45 micron filter papers. After all the filtering, the alkalinity of the solutions was again tested. If necessary, it was adjusted to pH 9.5.

With the filtered solutions at pH 9.5, the amino acids were now ready to be extracted by using a chelating resin, Chelex 100 (Bio-Rad Laboratories, 100-200 mesh, in Na form), the sodium form of Chelex 100 was converted to the copper form according to the procedure outlined by Seigil and Degens (1966). Two liters of alkaline seawater was eluted on a 1 cm diameter micro column containing approximately 10 ml of Cu-Chelex 100 resin. The flow rate was adjusted to 100 ml/hour. The amino acids were quantitatively isolated on the resin with other constituents in the eluant. The amino acids were then stripped off the resin with 150 ml of 3 M NH_4OH with a flow rate of 75 ml/hour. After the

elution with NH_4OH , the eluent was concentrated to 20 ml volume. The concentrated solution was desalted on a 15 ml cation-exchange resin column (Bio-Rad Laboratories, 50-100 mesh, AG 50 W-8X). The cation exchange column was then washed with 100 ml of 3 M NH_4OH to remove all the amino acids. The eluent was evaporated to dryness by using a Roto-Vap and a steam bath. Now the solid amino acids were ready to be derivatized.

DERIVATIZATION OF AMINO ACIDS

The isolated solid amino acids were derivatized to PTH-amino acids (3-phenyl-2 thiohydantoins) by using a microsynthesis method according to Sjoquist (1957). A general structure of a PTH-amino acid is given below.

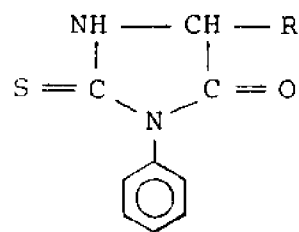

Since the quantity of total amino acids in two liters of seawater was not known, the quantities of reagents used in synthesis were one hundred-fold, and the reaction was allowed to stand overnight instead of 6½ hours as indicated in the procedure. After the synthesis, the PTH-amino acids were dissolved in spectro grade methanol to be analyzed by the high pressure liquid chromatography (Lominar and Kingdon, 1976).

ANALYSIS OF PTH-AMINO ACIDS BY HIGH PRESSURE LIQUID CHROMATOGRAPHY

PTH-amino acids were analyzed on a Water Associates Model

6000 solvent pump system with a U6K sample injector and a Differential U.V. detector. The data were displayed on a Linear Instrument Corp recorder. A standard solution of 20 PTH-amino acids (MCB) was used to calibrate a 3.2 I.D.-25 cm length-Li Chrosorb reverse phase 10 microns column by Altek Scientific, Inc. The elution solvent was a 65/35 (%V) H₂O-CH₃OH systems which had been degassed and filtered with 0.2 micron Millipore filter. The standard mixture of PTH-amino acids was separated and identified by retention times and by spiking with individual PTH-amino acids.

The PTH-amino acids of seawater sample were eluted on HPLC under identical conditions as the standard mixture. They were identified by their retention times and by spiking with standard individual amino acids. The following list indicates the amino acids present in the sample with the relative quantities. This sample is from station CTP 2 in the outer harbor, which is in the "zone of biological enrichment".

Amino Acid	Relative Quantity
Cystine	Trace
Aspartic Acid	Large
Glutamic Acid	Medium
Arginine	Large
Serine	Large
Threonine	Small
Glycine	Medium
Alanine	Medium
Tyrosine	Medium
Proline	Small
Methionine	Medium

Amino Acid	Relative Quantity
Valine	Medium
Histidine	Large
Lysine	Medium
Isoleucine	Medium
Leucine	Medium

Cystine, Asparagine, and Tryptophane may be present in trace quantities. The instrument was not sensitive enough to positively confirm their presence.

LITERATURE CITED

- Lominar, G.D., and H.S. Kingdon. 1976. A Simple and In-expensive High Pressure Liquid Chromatographic System as an Adjunct to Gas Chromatography in Identification of Amino Acid Phenylthiohydantoin. Archives of Biochem and Biophys. 173, pp. 320-325.
- Seigel, A., and T. Degens. 1966. Concentration of Dissolved Amino Acids from Saline Waters by Ligand-Exchange Chromatography. Science 151, pp. 1098-1101.
- Sjöquist, J. 1957. Determination of Amino Acids as Phenyl Thiohydantoin Derivatives. Arkiv for Kemi, 11, p. 129
- Williams, J., T. Berman, and O. Holm-Hansen. 1976. Amino Acid Uptake and Respiration by Marine Heterotrophs. Marine Biology, 35, pp. 41-47.

PART D.

THE EFFECTS OF WASTE EFFLUENTS ON FISH POPULATIONS
IN THE LOS ANGELES HARBOR

- I. Bioassay Studies of Fish
- II. Enhancement Studies

by

Gary D. Brewer, Ph.D.
Harbors Environmental Projects
University of Southern California
Los Angeles, California 90007

THE EFFECTS OF WASTE EFFLUENTS ON FISH POPULATIONS
IN THE LOS ANGELES HARBOR

by

Gary D. Brewer, Ph.D.
Harbors Environmental Projects
University of Southern California

INTRODUCTION

Damaging effects of sewage on fish and other marine life have generally been attributed to the introduction of poisonous compounds, the decrease of dissolved oxygen from bacterial respiration, increased turbidity, the encouragement of fish disease, the smothering of benthic animals by deposited solid matter, a general shift in the biological balance, and the production of tastes and odors in fish and shellfish (Tsai, 1975). A reduction in dissolved oxygen and formation of septic conditions by bacterial decomposition is cited as the major cause of fish kills, the exclusion of fishes, and generally "unhealthy" conditions for other marine life (Turner, 1960).

Studies on the effects of Hyperion sewage discharged in Santa Monica Bay have been made by Hume et al. (1962), Hume and Carber (1967), Carlisle (1969, 1972), Ludwig and Storrs (1970), and SCCWRP (1974, 1975). These studies have indicated that fluctuation in fish abundance in Santa Monica Bay were not the result of waste discharge. Some species apparently avoided the area of waste discharge while others were attracted to it. These and other studies suggest that variation in fish abundance

and diversity off Santa Monica and Palos Verdes result more from depth, temperature, dissolved oxygen, and seasonal variability than from the direct impact of wastes. Grigg and Kiwala (1970) found that the number of species at stations around the White's Point outfall off Palos Verdes was negatively correlated with the amount of fine grain organic laden sediments.

Surveys by California Department of Fish and Game biologist-divers found some fishes concentrated at the terminus of the Orange County outfall where they were apparently feeding directly on the effluent itself (Turner et al., 1966). Other animal assemblages nearby appeared typical except that the number of species incrusting the last 100 feet of the outfall pipe was limited as compared to the central section, and species diversity and numbers on a nearby artificial reef were less than was observed on similar reefs in Santa Monica Bay.

There is overwhelming evidence that the addition of managed amounts of sewage and fish cannery wastes can and does have long term beneficial effects on fisheries (Bardach, 1968; Bardach and Rhyther, 1968; Thorsland, 1971; Bascom, 1974). Yields of fish and shellfish from aquaculture ponds supplemented with raw sewage are often great (Tsai, 1975; Bardach Rhyther, and McLarney, 1972). The natural fertilization of lakes in the Pacific northwest from decomposing salmon carcasses has been discussed by Krokhin (1967), who has suggested that the potential deficit from salmon removed by the fishery should be replaced by artificial fertilization.

The Los Angeles-Long Beach Harbor is itself a large, potentially high-yield aquaculture pond. Phytoplankton productivity and standing stocks of fishes are apparently greater here than in other southern California marine waters. The input of organic matter from the TITP plant and the fish canneries in the form of both particulate and dissolved matter is undoubtedly a significant factor in the harbor's richness. The complete elimination of these valuable foodstuffs through secondary treatment or discharge outside the harbor would reduce the biomass of organisms. Fishes, including the northern anchovy, would be affected. There must be a compromise between the potentially inhibitory and lethal aspects of sewage discharge and the potential long term benefits from increased productivity of adjacent receiving waters.

Wastes from the fish canneries and TITP in high concentration are inhibitory, mainly as a result of oxygen depletion from high microbial activity and possibly excessive ammonia levels. Field and laboratory studies have demonstrated that in lesser concentration these materials provide raw materials for direct utilization by fishes and other organisms. Although the diversity of fishes adjacent to the outfalls is relatively low, the numbers of individuals far exceed numbers found elsewhere. Between 400 and 1000 feet from the outfalls, diversity and numbers of fishes may be higher than at similar depths anywhere in southern California.

The studies reported herein were undertaken to determine

more accurately the effects of the cannery and treatment plant wastes on the fish populations in the outer harbor. Techniques were not necessarily intended to duplicate standard toxicity monitoring methods, but were designed to learn more about the impacts in the ecosystem.

I. BIOASSAY STUDIES OF FISH

Methods

Samples of Terminal Island Treatment Plant sewage were obtained at the surface of the primary dilution zone (stn. 7, the center of the effluent boil) on nine dates between 18 March and 12 August 1976. Effluent from Way Street Outfall (Fig. D1) was sampled at the surface within four feet of the partially submerged pipe (stn. 6) on 18 dates between 18 March and 6 August 1976. Samples of waste from the Starkist Outfall (station 5) were taken on ten dates between 16 May and 6 August. Because the Starkist Outfall pipe discharges above the high tide level, samples were taken within four feet of shore directly below the discharge.

In addition, samples of Hyperion Treatment Plant primary treated and secondary treated waste and Terminal Island primary treated waste (i.e., before mixing with sea water at the outfalls) were obtained for bioassay.

Sea water for dilutions and for controls consisted of sand filtered, ultraviolet light-treated sea water from the Long Beach Harbor. Test dilutions were made and experiments initiated within one hour after sample collection, with the exception of

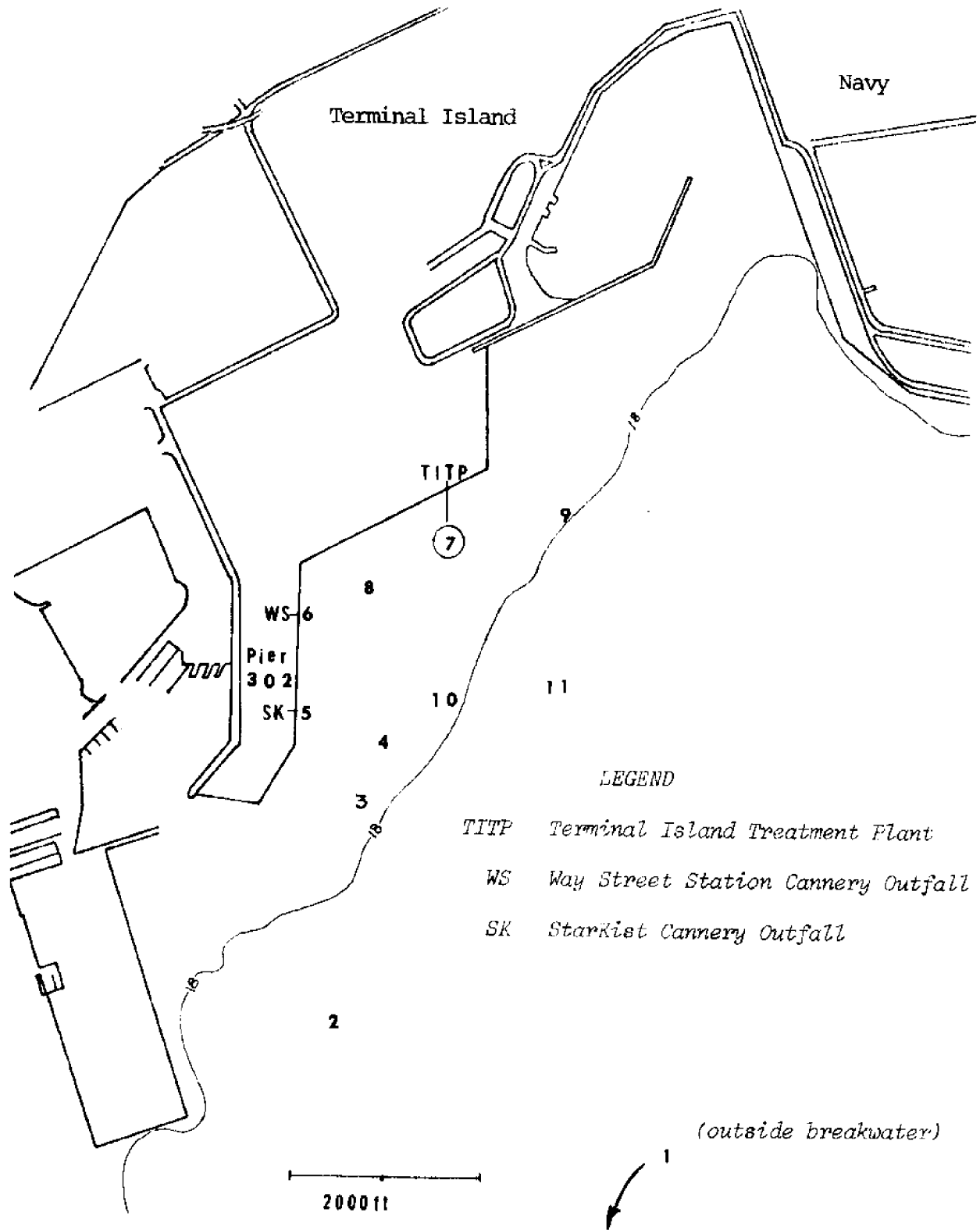

Figure D 1 Cannery/Treatment Plant (CTP), Special Stations, 1976

the Hyperion and TITP within-plant wastes which were stored at 4° C for 18 hours before being assayed.

Ten-liter aliquots of the cannery and TITP samples taken from the primary dilution zones on 19 May were aerated vigorously with four liters of air per minute. After 24 and 48 hours of aeration, sub-samples were withdrawn and dilutions prepared.

Samples of surface water from the secondary dilution zone (receiving water field (Fig. D2) surrounding the cannery and TITP discharges were obtained on ten dates between 28 April and 28 July 1976. The samples were assayed without further dilution. All other procedures were maintained as above.

Species Tested by Bioassay

The northern anchovy (*Engraulis mordax*) inhabits the harbor in large numbers, most of which are in the 0-1 year age class. They are a delicate fish, not easily reared in captivity.

Northern anchovy eggs were captured by a surface-towed plankton net (333 μ) within San Pedro Bay. Anchovy eggs which had been spawned the previous evening (i.e., blastodisc stage embryos, 10-14 hours after fertilization) were sorted from the plankton sample and subsequently placed in 250 ml or one l incubation jars containing the test dilutions. The jars were partially submerged in a water table and maintained at ambient environmental temperatures. Temperatures varied between 14° and 20° C during the five-month experimental period. However, during each 96-hour exposure period, temperatures varied no

more than plus or minus 1.0 C. Photoperiod was maintained with 12 hours light (700 lux) and 12 hours dark (16 lux) by incandescent bulbs controlled by a timer. The developing embryos and larvae were left undisturbed for 96 hours. No aeration was provided. No supplemental aeration was provided in the bioassay vessels except for one series of tests on September 21, which compared survival between unaerated and continuously aerated test dilutions. A stream of bubbles (about 100 per minute from the end of a pipette) was maintained in the aerated vessels.

At the conclusion of each 96 hour test, the number of viable larvae were counted. Each larva was examined individually for normal development and the absence of deformities. Only live, normal appearing larvae were considered survivors.

The killifish is a species commonly used in bioassay tests. *Fundulus parvipinnis* were seined from the Venice Canal and held in 950 liter acclimation tanks with flow-through, sand-filtered ultraviolet-treated seawater for at least two weeks before tests commenced. Temperatures, light intensity, and photoperiod were regulated as described above. The fish were fed a ration of Trout Chow equivalent to about 5% of their wet weight per day. The food was withheld for 24 hours before each test.

Shiner perch (*Cymatogaster aggregata*) were taken by dip net from the Long Beach Harbor and similarly acclimated.

Fish were transferred by dip net to 20 liter, glass test aquaria containing the waste effluent. No more than ten killifish or 3 shiner perch were placed in one aquarium. Air was bubbled into each aquarium through air stones at rates of at least 2 l/min. Aquaria were partially submerged in water baths which
Harbor Environmental Projects University of Southern California

maintained the aquaria at ambient environmental temperatures (17° - 18° C).

Results

Results of the sewage and cannery waste bioassays are detailed in appended Tables 14-21 and are summarized here as Table D1. Anchovy embryos and larvae are highly susceptible to the cannery and sewage wastes in bioassays that are without supplemental aeration. The lethal effects are apparently directly associated with high levels of organic material (see Total Organic Carbon and protein measurements, Table D2) which create excessive Biological Oxygen Demand (BOD) and subsequent low dissolved oxygen levels in the test dilutions (Tables D3a, 3b, 3c). The bioassay of the Hyperion primary and secondary wastes exemplify these lethal effects. Approximately 90% of the TOC (and BOD) is removed by secondary treatment, and hence, mortality of anchovy eggs and larvae is much reduced.

A comparison of the TITP bioassays on anchovy embryos and larvae shows that the TITP primary is lethal in small concentrations. However, the waste is rapidly diluted at the outfall pipe; survival of anchovy larvae exposed to samples from the sewer boil (the surface turbulence at the end of the pipe) is four to five times greater at the same dilutions.

Aeration of the TITP effluent boil samples before assaying resulted in decreased toxicity within 24 hours (Table D4a). Similarly, mortality was decreased within 48 hours when a sample of Way Street cannery effluent was aerated (Table D4b). Mortality was roughly unchanged for the sample of effluent from the StarKist cannery outfall (Table D4c). Continued aeration past

Table D1. Bioassay Summary

<u>TITP (Sewer Boil)</u>			
	Anchovy Embryos and Larvae (unaerated)	Killifish (aerated)	Shiner Perch (aerated)
100% survival	≤ 20% sewage	≤ 100% sewage	≤ 90% sewage
50% survival	25% sewage	---	---
0% survival	≥ 70% sewage	---	---
<u>TITP (Primary)</u>			
100% survival	≤ 5% sewage	---	---
50% survival	7-8% sewage	---	---
0% survival	≥ 15% sewage	---	---
<u>Starkist Cannery (Effluent Boil)</u>			
100% survival	≤ 5% effluent	100% effluent	? 60-90% effluent
50% survival	17-18% effluent	---	---
0% survival	≥ 50% effluent	---	---
<u>Way Street Outfall (Effluent Boil)</u>			
100% survival	< 5% effluent	90% effluent	80% effluent
50% survival	17-18% effluent	---	95% effluent
0% survival	≥ 80% effluent	---	---

(continued)

Table D1. Bioassay Summary (continued).

<u>Hyperion (Primary)</u>	
	Anchovy Embryos and Larvae (unaerated)
100% survival	< 1% sewage
50% survival	3-4% sewage
0% survival	≥ 15% sewage
<u>Hyperion (Secondary)</u>	
100% survival	< 60% sewage
50% survival	65% sewage
0% survival	≥ 70% sewage
<u>Hyperion Chlorinated (primary and secondary mix)</u>	
100% survival	≤ 5% sewage
50% survival	7-8% sewage
0% survival	≥ 10% sewage

Table D2. Results of Total Organic Carbon (TOC) and Protein Analysis for Cannery Effluents and Sewage Wastes.

July 22			June 25	
Station	TOC (mg/l)	Protein (mg/l)	Station	TOC (mg/l)
1S	15	1.2	5S	18
1D	11	1.2	5D	-
2S	8	1.8	6S	20
2D	9	1.3	6D	10
3S	-	1.8	7S	7
3D	4	1.1	7D	12
4S	16	10.7	July 8	
4D	8	1.9	5S	25
5S	18	29.6	6S	17
5D	4	1.9	7S	11
6S	59	41.7	August 19	
6D	22	5.1	Hyperion primary	149
7S	7	6.2	Hyperion secondary	26
7D	-	0.9	Hyperion Chlorinated Primary-Secondary Mix	67
8S	14	2.8		
8D	17	1.0		
9S	18	16.7		
9D	15	2.7		
10S	16	11.9		
10D	-	0.9		
11S	8	9.0		
11D	-	0.7		

Note: S stations = Surface
D = 1 meter above bottom

Table D3a. Terminal Island Treatment Plant Sewage Bioassay.

Primary Dilution Zone (sewage boil) Surface Water Sample
 Dissolved Oxygen Measurements mg/l* (no aeration)
 May 11, 1976

Conc. (%)	Initial Measurement	24-hour Measurement	48-hour Measurement	72-hour Measurement
100	1.4	0.4	0.6	1.0
75	2.9	0.5	1.3	2.2
50	3.5	0.9	2.5	3.1
30	4.5	2.9	4.4	5.3
20	5.0	3.6	4.2	5.4
10	5.5	5.2	5.4	6.3
5	5.5	6.3	5.9	6.4
1	5.5	6.2	6.0	6.5
0 (Control)	5.2	6.2	5.8	7.3

* Samples maintained at 20° C.

Table D3b. Way Street Station Effluent Bioassay.

Primary Dilution Zone Surface Water Sample
 Dissolved Oxygen Measurements mg/l* (no aeration)
 May 11, 1976

Conc. (%)	Initial Measurement	24-hour Measurement	48-hour Measurement	72-hour Measurement
100	0.4	0.3	0.4	0.2
75	0.4	0.3	0.4	0.8
50	0.7	0.4	0.4	0.4
30	2.9	0.4	2.4	2.9
20	4.3	1.1	4.1	4.6
10	4.6	2.6	4.5	5.4
5	5.2	4.5	5.5	5.6
1	5.4	6.2	6.1	6.4
0 (Control)	5.2	6.2	5.8	7.3

* Samples maintained at 20° C.

Table D3c. StarKist Effluent Bioassay.

Primary Dilution Zone Surface Water Sample
 Dissolved Oxygen Measurements mg/l* (no aeration)
 May 11, 1976

Conc. (%)	Initial Measurement	24-hour Measurement	48-hour Measurement	72-hour Measurement
100	0.1	1.1	0.1	0.2
75	0.2	0.2	0.1	0.2
50	0.2	0.2	0.2	0.3
30	0.2	0.2	0.3	0.3
20	0.3	0.3	0.4	0.3
10	1.5	0.4	0.5	0.9
5	3.5	0.7	0.7	3.0
1	5.1	4.7	5.2	6.5
0 (Control)	5.2	6.2	5.8	7.3

* Samples maintained at 20° C.

Table D4a. Terminal Island Treatment Plant Sewage Bioassay
Engraulis mordax Embryos and Larvae, 96-hour Tests

Primary Dilution Zone (sewage boil) Surface Water
 Dilutions

Conc. (%)	Initial Results Mar. 19		24-hour Aeration Mar. 20		48-hour Aeration Mar. 21	
	(N)	(Mort.)	(N)	(Mort.)	(N)	(Mort.)
100					10	10
90			10	10	10	10
80			10	10	10	6
70			10	10	10	4
60			10	9	10	1
50	10	10	10	10		
40	10	10	10	0		
30	10	7	10	0		
20	10	0	10	2		
10	10	0				
5	10	1				
1	10	0				

Table D4b. Way Street Outfall Bioassay

Engraulis mordax Embryos and Larvae, 96-hour Tests

Primary Dilution Zone (effluent boil) Surface Water Dilutions

Conc. (%)	Initial Results May 19		48-hour Aeration May 21	
	(N)	(Mort.)	(N)	(Mort.)
100			10	10
90			10	9
80			10	10
70			10	10
60			10	7
50	10	10	10	3
40	10	8	10	1
30	10	9		
20	10	6		
15	10	1		
10	10	2		
5	10	1		
1	10	0		

Table D4c. Starkist Outfall Bioassay
Engraulis mordax Embryos and Larvae, 96-hour Tests
 Primary Dilution Zone (effluent boil) Surface Water
 Dilutions

Conc. (%)	Initial Results May 19		48-hour Aeration May 21	
	(N)	(Mort.)	(N)	(Mort.)
100				
90				
80			10	10
70			10	10
60	10	10	10	10
50	10	10	10	9
40	10	5	10	9
30	10	4	10	6
20	10	3	10	1
15	10	1		
10	10	1		
5	10	0		
1	10	0		

48 hours might further reduce the lethal qualities of these samples by supplying the necessary dissolved oxygen to satisfy the high BOD and maintain the organisms. Complex changes may occur in the chemistry of the solution, however.

Results of tests on anchovy eggs in aerated and unaerated effluent are given in Table D5. Uniform bubbles could not be maintained in all 30 aerated vessels simultaneously. Fluctuations occurred during the test period which obviates some of the results. In some cases, the bubbling was unintentionally stopped in some vessels; in others, the aeration was excessive and probably contributed to the mortality of the larvae. Data from several test dilutions were eliminated from Table D5 because of these factors. These data indicate that low oxygen levels only partially explain the lethal response of the waste effluents to anchovy embryos and larvae. While survival was enhanced with aeration, toxic components are apparently present. The identification of these toxic contaminants must await further study.

Results of the secondary dilution zone assays are given in Table D6. The most striking feature of the results is the relatively sharp gradient between extreme toxicity and 100% survival of closely approximated stations (Figure D2). Apparently the cannery outfalls exert an overriding influence on the toxicity of the effluent field to *E. mordax* embryos and larvae. The toxicity of the surface waters between stations 7 and 14 gradually diminish; mortality is inversely proportional to the distance from the cannery outfall, with little influence from

Table D5. Starkist, Way Street, and Terimal Island Treatment Plant Sewage Bioassay.
Engraulis mordax embryos and larvae, 96 hour tests.
 Primary dilution zone, surface water dilutions.
 Comparison of unaerated and continuously aerated samples.

effl. conc.	Starkist		Way Street		TTPP	
	survival % unaerated	survival % aerated	effl. conc.	survival % unaerated	effl. conc.	survival % aerated
100%			100%		100%	0
90%			90%		90%	10
80%			80%	0	80%	0 20
70%		0	70%	0	70%	0 60
60%		0	60%	0	60%	10 60
50%		0	50%	0	50%	20
40%		0	40%	0	40%	70 100
30%	0	0	30%	0	30%	50 100
20%	0	0	20%	0	20%	80 80
15%	0		15%	40	15%	90
10%	0	70	10%	70	10%	80
5%	70	100	5%	70	5%	100
1%	90		1%	100	1%	90

Control - Unaerated 100%
 Aerated 80%

Table D6. Terminal Island Treatment Plant Sewage Bioassay. *Engraulis mordax* Embryos and Larvae, 96-hour Tests. Secondary Dilution Zone - Surface Water Samples.

GDB Stations	Apr. 28		May 4		May 7		May 19		May 21		May 29		June 4		June 28		July 28	
	(N)	(Mort.)	(N)	(Mort.)	(N)	(Mort.)	(N)	(Mort.)	(N)	(Mort.)	(N)	(Mort.)	(N)	(Mort.)	(N)	(Mort.)	(N)	(Mort.)
1							10	0	10	0	10	0			10	0		
2							10	0	10	0	10	1						
3													10	0			10	5
4							10	6	10	1	10	8	10	0	10	3		
5							10	3	10	1	10	0	10	3	10	0		
6																	10	10
7	20	20	10	10														
8	20	20	10	10														
9	20	20	10	10			10	4	10	4	10	10						
10			10	10			10	9	10	1	10	7	10	10				
11													10	7				
12							10	0	10	1	10	0	10	2	10	2		
13													10	0	10	0	10	5
14															10	0	10	3
15													10	4	10	1	10	9
16													10	0	10	0	10	0
Control			10	1			10	1					10	0	10	0		

Table D6. Continued. Summary of Results

GDB Stations	Total N	Total Mortality	Survival (%)	Adjusted Survival %
1	50	0	100.0	104.8
2	40	1	97.5	102.2
3	20	5	75.0	78.6
4	60	26	56.7	59.4
5	60	9	85.0	89.1
6	30	22	26.7	30.0
7	35	35	0.0	0.0
8	35	35	0.0	0.0
9	65	58	10.8	11.3
10	65	47	27.7	29.0
11	30	12	60.0	62.9
12	60	13	78.4	82.2
13	30	5	83.4	87.4
14	30	8	73.4	76.9
15	50	22	56.0	58.7
16	50	6	88.0	92.2
Control	30	2	95.4	100.0

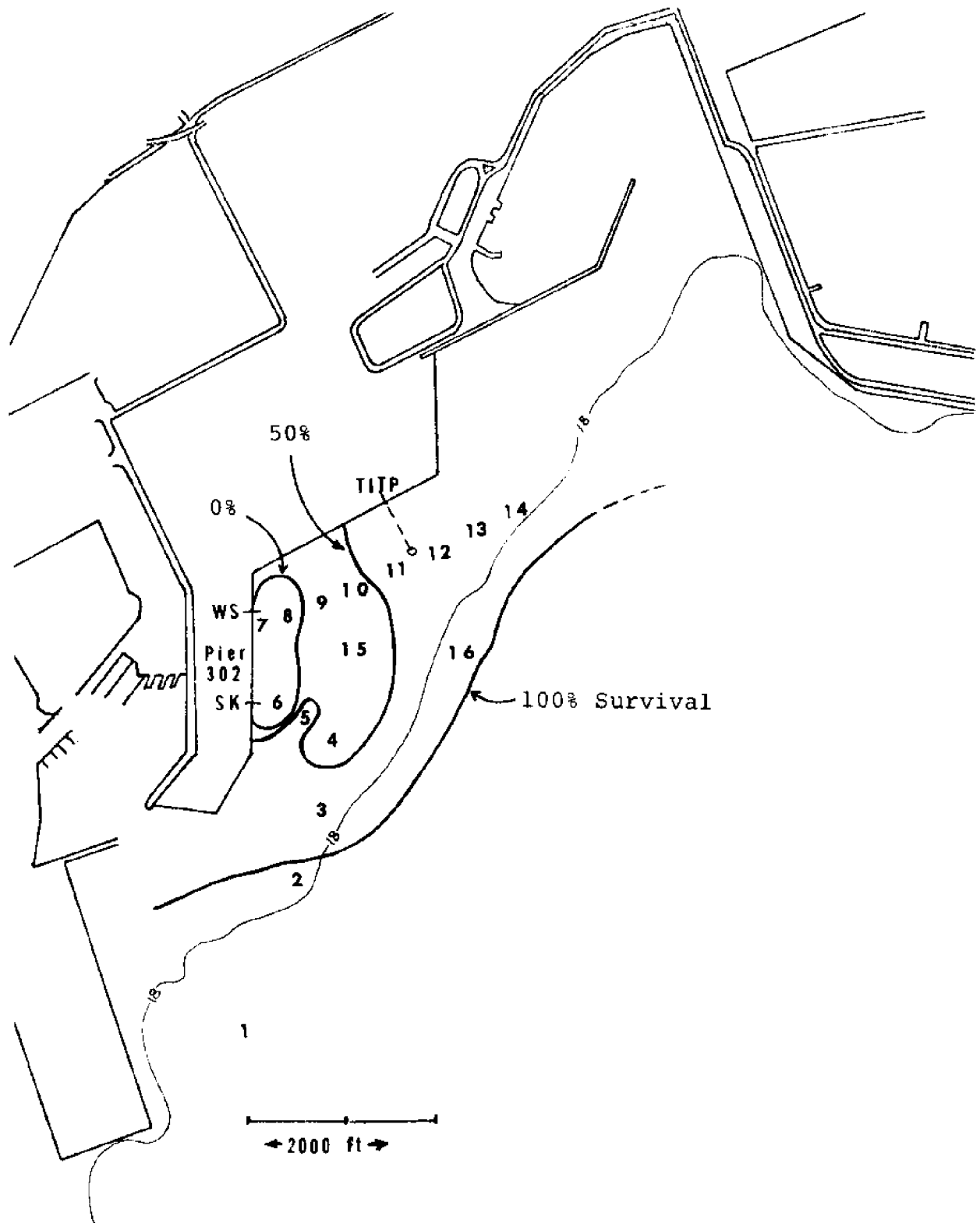

Figure D2. GDB Stations for Anchovy Eggs and Larvae Survival Contours.

the TITP outfall (except within the boil itself).

Bioassays with killifish and shiner surfperch utilized aeration to maintain oxygen at tolerable levels (i.e., above 5 ppm). Nevertheless, some mortality occurred at the highest effluent concentrations. Excessive levels of ammonia (as NH_3) are suspect, but this supposition requires additional experimentation. Few studies have documented the lethal levels of ammonia on marine fishes. However, from available literature, ammonia concentrations of 1mg/l or below may be detrimental (Tsai, 1975).

Discussion

The toxicity of the primary and secondary dilution zones of the effluent field at a given dilution or station on different test dates was highly variable. Samples from GDB Stn. 5 were harmless to *E. mordax* embryos and larvae on 21 May, but were lethal four days later. A fifty per cent dilution of TITP effluent from the sewer boil was tolerated by embryos and larvae on 18 March, but was 100 per cent lethal on two other dates. This variability in toxic effect may reflect day to day differences in the TITP effluent composition, differences in the cannery wastes, a diversity of modifying oceanographic conditions including tidal cycle and height, wind direction and strength, receiving water temperatures, and numerous biological influences such as plankton blooms.

The close proximity of the cannery outfalls to the TITP outfall obscures an understanding of the potential impact of each source. The station data reflect the overwhelming influence of

the cannery outfalls. Although the combined flow of the cannery wastes is about 1/3 less than the TITP plant, the BOD of the cannery wastes is about five times the TITP levels.

The major limiting factor in the anchovy embryo and larvae bioassay was undoubtedly oxygen. Although detailed studies on the oxygen requirements of *E. mordax* embryos and larvae are lacking, data on other marine fish larvae have shown levels below 4-5 mg/l to be detrimental (Alderdice and Forrester, 1971).

The lethal effects of the effluents are decreased by aeration before testing. Although it is possible that toxic, volatile components are driven off by bubbling, it is likely that the BOD fraction is gradually eliminated during vigorous aeration. A reduced organic load, and hence, reduced bacterial metabolism, would afford the developing anchovies higher oxygen tensions during the bioassay.

Addendum

Fish Cannery Waste Bioassay with *Fundulus parvipinnis*Introduction

Previous fish cannery bioassay data on the killfish *Fundulus parvipinnis* were restricted to lethal effects of water samples drawn from the primary dilution zone. Additional studies were undertaken to assess the potential toxicity of the (1) undiluted waste from the Way St. Station and the Starkist outfall and (2) of the secondary dilution zone. In addition, chemical analyses were performed on samples of the undiluted waste by Dr. Chen.

Methods

Techniques were identical to those used in the report "Bioenhancement Studies of the Receiving Waters in Outer Los Angeles Harbor" (Brewer). Samples were drawn from the Way St. pumping station and from the Starkist outfall pipe on October 29. A geometric series of concentrations (100, 75, 56, 42, 32, and 24%) were prepared using filtered, UV sterilized dilution water. In addition, samples of surface water from the secondary dilution zone were obtained at distances of 7, 15, and 30 meters from the Starkist outfall pipe. Temperatures varied between 17.9 and 20.2⁰ C during the tests. Ten fish were tested in each concentration or sample.

Despite vigorous aeration in each aquarium, O₂ could not be maintained at satisfactory levels in all tanks (i.e. above 5.0 mg/l). However, mortality can not be attributed to low O₂

exclusively since levels as low as 2.8 mg/l were not lethal in the Way St. Station effluent. Results suggest that toxic material is present in the Starkist effluent.

Mortality could be eliminated if the discharge volume in the Starkist Outfall were increased two-fold with clean sea water.

Note: Results of chemical analyses will be available soon which may suggest potentially toxic materials in the effluent. These results may call for additional bioassays.

Results

Way St. Station	Cumulative Mortality				Range pH	Range Salinity	Range Dissolved Oxygen
	Conc. 24	48	72	96			
100	0	0	0	0	7.2-7.7	27.7-30.1	2.8-7.3
75	0	0	0	0	7.3-7.8	28.6-31.2	3.9-7.1
56	0	0	0	0	7.3-7.7	29.2-32.0	4.1-7.7
42	0	0	0	0	7.4-7.7	29.8-32.6	5.0-8.8
32	0	0	0	0	7.6-7.8	29.7-33.0	6.1-7.1
24	0	0	0	0	7.6-7.8	30.4-33.3	5.4-7.0

Starkist

100	5	10	10	10	7.0-8.0	20.4-21.2	2.1-6.7
75	3	10	10	10	7.0-7.4	24.1-24.6	2.9-4.8
56	2	3	6	6	6.9-7.4	24.6-26.4	3.5-6.0
42	2	2	2	2	7.3-7.8	26.3-28.9	5.1-7.2
32	0	0	0	0	7.1-7.9	27.4-30.1	6.1-7.4
24	0	0	0	0	7.4-7.7	28.3-31.0	6.0-7.8
Control	0	0	0	0	7.6-7.9	31.3-34.0	6.3-7.4

Secondary Dilution Zone

Sample
Distance from Outfall (m)

7	0	0	0	0
15	0	0	0	0
30	0	0	0	0

II. ENHANCEMENT STUDIES

Methods

Zooplankton

In order to measure the influence of cannery and TITP wastes on the lower trophic levels, surface zooplankton was captured by a 333 μ mesh plankton net in February 1976 along two transects; within 30 meters of the shore adjacent to the Way Street and Starkist outfalls and within a radius of 30 meters adjacent to the TITP sewage boil (Figure D3). Each trawl filtered approximately 50 m³ of water.

Fishes

Field Studies. An accurate accounting of the abundance and diversity of fishes gives an excellent measure of the "healthiness" of a marine habitat as opposed to various nebulous abiotic parameters such as dissolved oxygen or BOD (Wheeler, 1970; Sinderman, 1972). Gill-net, beach seine, and otter trawl were utilized to sample fishes occupying the area adjacent to the cannery and TITP outfalls (Figure D3). In addition, numerous observations were made of sport angler catches in the same area.

Laboratory Studies. Fishes may feed directly on the particulate or dissolved organic material which is discharged from the cannery and TITP outfalls. This hypothesis was tested by 1) examination of the gut contents of fishes collected near the outfalls and 2) by offering laboratory fish a ration of sewage and cannery wastes.

Three shiner surfperch (*Cymatogaster aggregata*) were placed

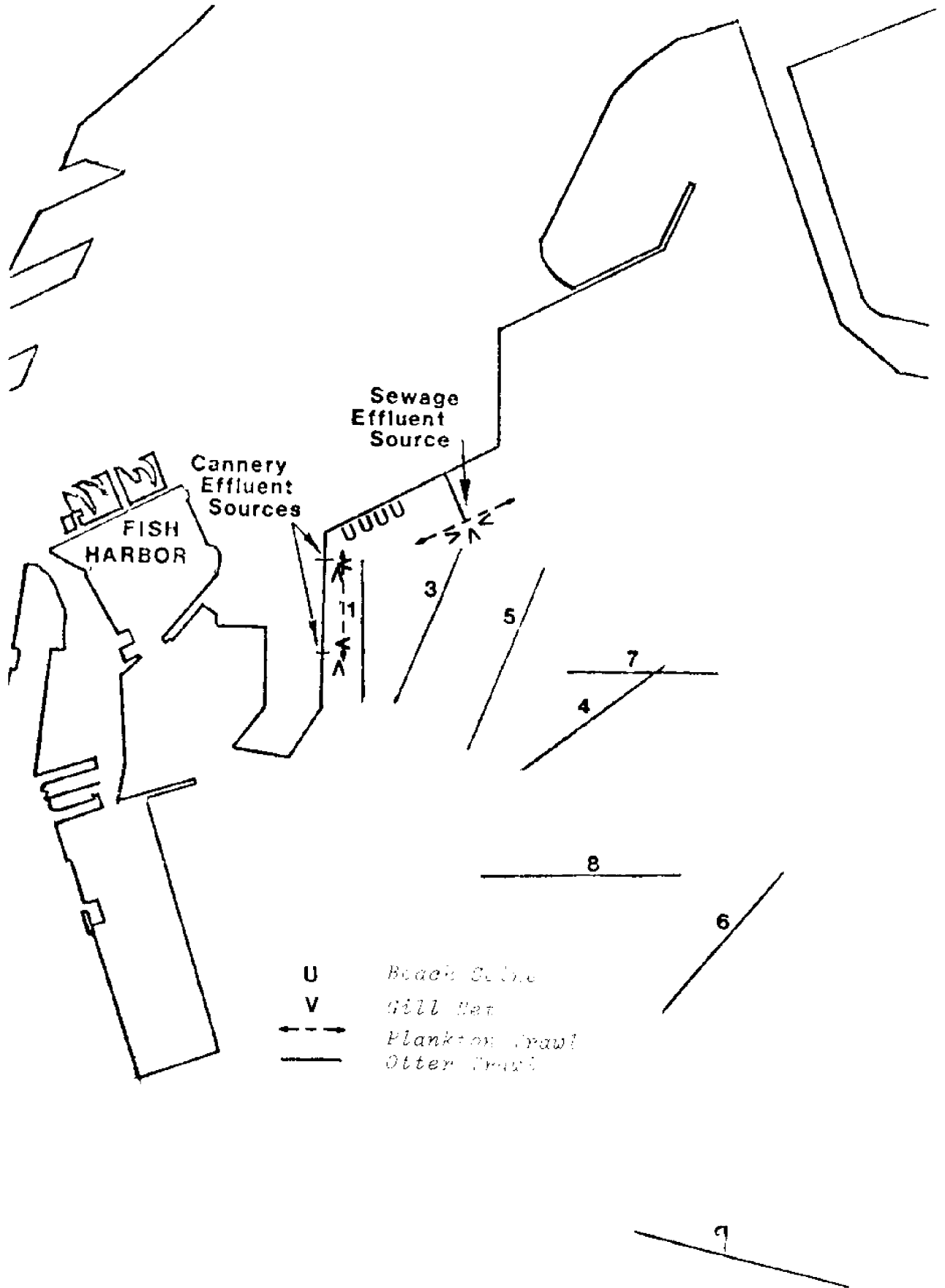

Figure D3. Fish Sampling Stations and Waste Discharge Locations.

in each of five 5-gallon aquaria. Each group was "fed" one of the following rations:

- 1) Trout Chow equivalent to 5% of the fish's wet weight per day.
- 2) Particulate material from the Way Street cannery outfall pipe equivalent to 5% of their wet weight per day.
- 3) Way Street cannery effluent samples from the primary dilution zone (sewer boil) equivalent to 5% of the aquarium volume per day.
- 4) TITP effluent samples from the primary dilution zone (sewer boil) equivalent to 5% of the aquarium volume per day.
- 5) Starvation control.

Each day the water in each aquarium was replaced with fresh, filtered, UV-treated water from Long Beach Harbor.

Anchovy eggs, captured by plankton net (see methods under Bioassay Studies) were utilized in experiments on the potential uptake and utilization of organic materials from the cannery and TITP outfalls. Embryos and larvae were exposed to several dilutions of waste, maintained at 20° C and measured four days after hatching. Any significant increase in length attained must be considered as survival enhancement.

Results

Zooplankton

In the immediate vicinity of the Terminal Island Treatment Plant outfall, zooplankton numbers show a 20-fold increase over

the mean abundance in the harbor during February as determined by the Harbors Environmental Projects (1975) (see Table D7,8, & 9) Assuming that zooplankton motility is low relative to water currents and circulation patterns, this greatly enhanced abundance appears to be due to a local increase in zooplankton production.

The zooplankton of the Los Angeles-Long Beach Harbor is dominated by crustacean fauna. Seven dominant species compose 95% of the harbor's zooplankton (see Table D9). Of these species, copepods compose 69.8% and cladocerans compose 15.8%. The species composition of the zooplankton at the TITP outfall does not appear to differ significantly from the mean for the harbor.

In the immediate vicinity of the fish cannery waste discharge zooplankton abundance does not appear greatly different from the mean annual abundance in the harbor (see Table D8). However, the species composition is altered. Of the 7 dominant species, copepods compose 30.3% and cladocerans 45.7%. This large increase in the proportions of cladocerans is not explained by the available data, but McConaughy's study of *A. tonsa* indicates inhibitory effects on that usually dominant species. Data from the Allan Hancock Foundation (1975) suggest that cladoceran species generally have low tolerance to reductions in dissolved oxygen and salinity. These factors show no apparent inhibitory effect in the cannery discharge area.

Table D7. Zooplankton Species Composition of Surface Samples Taken by Plankton Net (333 μ mesh) in Transects Adjacent to the TITP Sewage Outfall and the Two Cannery Outfalls - February 23, 1976.

	Number per m ³ of Water Filtered	
	TITP Outfall	Cannery Outfalls
<i>Acartia tonsa</i>	24,672	555
<i>Acartia tonsa</i> (immature)	11,514	432
<i>Acartia clausi</i>	2,632	83
<i>Corycaeus anglicus</i>	164	103
<i>Paracalanus parvus</i>	1,645	206
<i>Paracalanus parvus</i> (immature)	1,069	21
<i>Podon polyphemoides</i>	8,060	1,501
<i>Evadne nordmanni</i>	3,125	452
<i>Oithona oculata</i>	--	21
Gastropod veliger	247	21
Brachyura zoea	411	--
Polychaete larvae	164	41
Cyphonautes larvae	82	41
Larvacea	984	5
Barnacle cypris	329	288
Barnacle nauplius	576	206
Pelecypod veliger	--	103
Fish eggs	--	82
Harpacticoid	--	21

Table D8. Zooplankton Numbers of the Outfalls Area, compared to Mean Harbor Concentrations.

Species	TITP Transect	Cannery Transect	Mean Harbor Conc.	Mean Feb. Conc. (1972-74)
<i>Acartia tonsa</i>	36,186	987	1,538	908
<i>Podon polyphemoides</i>	8,060	1,501	295	246
<i>Evadne nordmanni</i>	3,125	452	125	141
<i>Paracalanus parvus</i>	2,714	227	265	550
<i>Corycaeus anglicus</i>	164	103	42	138
Barnacle nauplii	576	206	110	-
Larvaceans	984	103	152	-

Table D9. Dominant Species of Zooplankton of the Outfalls Area compared to the Entire Harbor.

Species	% in Harbor Plankton	% in TITP Transect	% in Cannery Transect
<i>Acartia tonsa</i>	57.9	64.9	23.1
<i>Podon polyphemoides</i>	11.1	14.5	35.1
<i>Paracalanus parvus</i>	10.0	3.0	4.8
<i>Evadne nordmanni</i>	4.7	5.6	10.6
<i>Corycaeus anglicus</i>	1.9	0.3	2.4
Larvaceans	5.7	1.8	2.4
Barnacle nauplii	4.2	1.0	4.8

Fishes

Field Studies. Results of field sampling for fishes are given in Tables D10,11,& 12. It must be emphasized that no single technique effectively samples the fish population. Otter trawls sample the demersal (bottom associated) species; gill nets sample the upper water column, and beach seines are only effective over shallow sandy beaches.

Within 300-400 feet of the cannery and sewage outfalls the fish fauna is composed of approximately 12 species which are present in very large numbers near the surface. White croaker, topsmelt, and white surfperch dominate. Bottom dwelling fishes (i.e., flatfishes) are relatively uncommon in this area (see Otter trawl data, Table D12. Polluted sediments may be intolerable to halibut, turbot, and sanddabs, which are abundant farther offshore and are common at shallow depths off Belmont Shore (see the beach seine data, Table D11. The area surrounding the outfalls is fished heavily by shore fisherman, who generally use unbaited hooks and enjoy a phenomenally high catch rate by simply snagging the fish. The catch rate of the gill-net is at least an order of magnitude higher off the effluent outfalls than at comparable depths at other areas in the harbor (unpublished data, G. Brewer, D. Chamberlain).

Between 400-1500 feet from the outfalls, the diversity of fishes increases substantially and also the numbers of demersal fishes increase greatly (Table D12,Figure D3). Some of the increased diversity may be a function of depth, but the quality of the bottom sediments is undoubtedly a factor. This area

Harbors Environmental Projects University of Southern California

Table D10. Fishes Taken by Gill-net March 10 and 24, April 20, and June 10 Within a 100 ft. Radius of the TITP Outfall and the Two Cannery Outfalls.

TITP Outfall

<i>Embiotoca jacksoni</i>	black surfperch
<i>Phanerodon furcatus</i>	white surfperch
<i>Hyperprosopon argenteum</i>	walleye surfperch
<i>Amphistichus argenteus</i>	barred surfperch
<i>Genyonemus lineatus</i>	white croaker

Cannery Outfall

<i>Genyonemus lineatus</i>	white croaker
<i>Hyperprosopon argenteum</i>	walleye surfperch
<i>Amphistichus argenteus</i>	barred surfperch
<i>Cymatogaster aggregata</i>	shiner surfperch
<i>Atherinopsis californiensis</i>	jacksmelt
<i>Atherinops affinis</i>	topsmelt
<i>Phanerodon furcatus</i>	white surfperch

Table D11 Fishes Taken by Beach Seine on May 5 and June 10, 1976
at the Sandy Beach Adjacent to the Cannery and TITP
Outfalls (total of six sets)

<i>Atherinops affinis</i>	topsmelt
<i>Atherinopsis californiensis</i>	jacksmelt
<i>Genyonemus lineatus</i>	white croaker
<i>Phanerodon furcatus</i>	white surfperch
<i>Cymatogaster aggregata</i>	shiner surfperch
<i>Amphistichus argenteus</i>	barred surfperch
<i>Hyperprosopon argenteum</i>	walleye surfperch
<i>Anchoa compressa</i>	deepbody anchovy
<i>Seriphus politus</i>	queenfish

Fishes Taken by Beach Seine During the Spring of 1976
at Belmont Shore (total of six sets)

<i>Cymatogaster aggregata</i>	shiner surfperch
<i>Amphistichus argenteus</i>	barred surfperch
<i>Hyperprosopon argenteum</i>	walleye surfperch
<i>Mugil cephalus</i>	mullet
<i>Genyonemus lineatus</i>	white croaker
<i>Atherinops affinis</i>	topsmelt
<i>Anchoa compressa</i>	deepbody anchovy
<i>Engraulis mordax</i>	northern anchovy
<i>Urolophus haleri</i>	round stingray
<i>Menticirrhus undulatus</i>	California corbina
<i>Paralichthys californicus</i>	California halibut
<i>Hypsopsetta guttulata</i>	diamond turbot
<i>Platichthys stellatus</i>	starry flounder
<i>Seriphus politus</i>	queenfish

Table D12. Summary of Fishes Taken by Otter Trawl During March, May, and June, 1976

	<u>Station 1</u>	<u>Station 3</u>	<u>Station 4</u>	<u>Station 5</u>	<u>Station 6</u>
	<i>Citharichthys stigmaeus</i>	<i>Porichthys myriaster</i>	<i>Symphurus atricauda</i>	<i>Porichthys myriaster</i>	<i>Citharichthys stigmaeus</i>
	<i>Symphurus atricauda</i>	<i>Cymatogaster aggregata</i>	<i>Anchoa compressa</i>	<i>Paralichthys californicus</i>	<i>Kystreurus liolepsis</i>
	<i>Cymatogaster aggregata</i>	<i>Embiotoca jacksoni</i>	<i>Porichthys myriaster</i>	<i>Symphurus atricauda</i>	<i>Symphurus atricauda</i>
	<i>Embiotoca jacksoni</i>	<i>Phanerodon furcatus</i>	<i>Paralichthys californicus</i>	<i>Leptocottus armatus</i>	<i>Cymatogaster aggregata</i>
	<i>Genyonemus lineatus</i>	<i>Paralichthys californicus</i>	<i>Embiotoca jacksoni</i>	<i>Cymatogaster aggregata</i>	<i>Phanerodon furcatus</i>
		<i>Symphurus atricauda</i>	<i>Citharichthys stigmaeus</i>	<i>Hyperprosoon argenteum</i>	<i>Clevelandia ios</i>
		<i>Genyonemus lineatus</i>	<i>Cymatogaster aggregata</i>	<i>Embiotoca jacksoni</i>	<i>Pleuronechthys verticalis</i>
		<i>Atherinops affinis</i>	<i>Hyperprosoon argenteum</i>	<i>Platyrrhinoidis triseriata</i>	<i>Genyonemus lineatus</i>
			<i>Phanerodon furcatus</i>	<i>Genyonemus lineatus</i>	
			<i>Engraulis mordax</i>	<i>Seriphus politus</i>	
			<i>Paralabrax nebulifer</i>	<i>Atherinops affinis</i>	
			<i>Genyonemus lineatus</i>		
			<i>Sebastes rastrelliger</i>		
			<i>Pleuronectus verticalis</i>		
			<i>Seriphus politus</i>		
Total species	5	8	15	11	8
Total individuals	20	203	183	876	84
Mean species/rawl	1.7	5.5	7	6.6	6
Mean individuals/rawl	6.6	101.5	61	292	28

encompasses one of the richest areas for fishes in the entire harbor (Stephens et al., 1974; Hancock Foundation, 1975), and, indeed, for all of southern California.

Beyond 1500 feet from the outfall sites, the diversity of fishes drops off to normal harbor background levels which are still higher than most shallow water marine areas off southern California.

Laboratory Studies. Results of feeding studies are given in Table D13. Although the test fish in all experimental groups lost weight during the two week period, fish exposed to particulate matter and effluents from the cannery and sewage outfalls lost less weight than the starvation control group. These experiments must be repeated with larger numbers of animals. However, these preliminary observations indicate that shiner perch will ingest and assimilate waste material. In the natural environment, such material could replace and/or supplement their normal intake of naturally occurring food materials.

Experiments with anchovy embryos and larvae exposed to dilutions of cannery and sewage wastes (i.e., 0-20%) are as yet inconclusive. There is no obvious (statistical) trend of increased growth or survival of larvae exposed to the higher organic loads in the waste dilution when compared to larvae grown in control sea water. The short experimental duration may obviate analysis of potential long term differences.

Similarly, experiments with radioactively labeled amino acids which are exposed to anchovy embryos and larvae are inconclusive.

Although some uptake is apparent in the axenic cultures, the quantities appear to be quite low; hence, it is questionable whether increased growth and survival could occur.

Table D13. Feeding and Uptake of Organic Materials by *Cymatogaster aggregata* Exposed to Sewage and Cannery Wastes.

	Starva- tion Control	Trout Chow ¹	Cannery Partic- ulate Matter ²	Cannery Effluent ³	TITP Effluent ³
Initial Weight	51.75	40.94	53.81	49.33	58.20
Final Weight	49.32	40.49	51.92	47.41	56.12
Percent Change	-4.7	-1.1	-3.6	-4.1	-3.6

1 Fish were offered 5% of their wet weight per day of this ration.

2 Fish were offered 5% of their wet weight per day of this ration.

3 Samples of cannery and sewage effluents, taken from the North Cannery outfall and the TITP boil and equivalent to 5% of the aquarium volume, were added each day.

LITERATURE CITED

- Alderdice, D.F., and C.R. Forrester. 1971. Effects of salinity, temperature, and dissolved oxygen on early development of the Pacific Cod (*Gadus macrocephalus*). J. Fish. Res. Bd. Can. 28:883-902.
- Allan Hancock Foundation. 1975. Environmental investigations and analyses for Los Angeles-Long Beach Harbors, Los Angeles, California. A report to the U.S. Army Corps of Engineers, Los Angeles District. Harbors Environmental Projects. Univ. So. Calif. 552 p.
- Bardach, J.E. 1968. Aquaculture. Science 161:1098-1106.
- Bardach, J.E., and J.H. Ryther. 1968. The status and potential of aquaculture, particularly fish culture. U.S. Clearing-house, PB. 177:768.
- Bascom, W. 1974. The disposal of waste in the ocean. Sci. Amer. 231(2):16-25.
- California Department of Fish and Game. 1976. Guidelines for performing static acute toxicity fish bioassays in municipal and industrial wastewaters. Report to the California State Water RESources Control Board. 65 p.
- Carlisle, J.G., Jr. 1969. Results of a six-year trawl study in an area of heavy waste discharge: Santa Monica Bay, California. Calif. Fish and Game 55:26-46.
- Carlisle, J.G., Jr. 1972. A trawl study in an area of heavy waste discharge: Santa Monica Bay, Calif. In Marine Pollution and Sea Life. Fishing News Ltd. (Lond.) 417-421.
- Grigg, R.W., and R.S. Kiwala. 1970. Some ecological effects of discharged wastes on marine life. Calif. Fish and Game 56:145-155.
- Hume, N.B., C.G. Gunerson, and C.E. Imel. 1962. Characteristics and effects of Hyperion effluent. Jour. Wat. Pollut. Contr. Fed. 34:15-35.
- Hume, N.B., and W.L. Carber. 1967. Marine disposal of digested screened wastewater solids. Proc. 3rd Int. Conf. Wat. Pollut. Res. Munich, 1966, 3:243-262.
- Krokhin, E.M. 1967. Influence of the intensity of passage of the sockeye salmon *Oncorhynchus nerka* (Wald.) on the phosphate content of spawning lakes. Izd. "Nauka", Leningrad 15(18:26-31. (Fish. Res. Board Can. Trans. Ser. 1273.)

- Ludwig, H.F., and P.N. Storrs. 1970. Effects of waste disposal into marine waters. A survey of studies carried out in the last ten years. *Wat. Res.* 4:709-720.
- Neess, J.C. 1949. Development and status of pond fertilization in central Europe. *Trans. Amer. Fish. Soc.* 76:335-358.
- SCCWRP (Southern California Coastal Water Research Project). 1974. Annual Report. El Segundo, California, 197 p.
- SCCWRP. 1975. Annual Report. El Segundo, California.
- Sindermann, C.J. 1972. Some biological indicators of marine environmental degradation. *Jour. Wash. Acad. Sci.* 62(2): 184-189.
- Stephens, R.S., Jr., C. Terry, S. Subber, and M. J. Allen. 1974. Abundance, distribution, seasonality, and productivity of fish populations in Los Angeles Harbor, 1972-1973. In *Marine Studies of San Pedro Bay, California. Part 4.* Allan Hancock Foundation and Sea Grant Program, Univ. So. Calif. p. 1-42.
- Thorsland, A.E. 1971. Potential uses of waste water and heated effluents. The use of domestic water for fish culture in Poland. *FAO EIPAC OCC. pap. No. 5*, 23 p.
- Tsai, C. 1975. Effects of sewage treatment plant effluents on fish: A review of literature. Chesapeake Research Consortium, Inc., Publ. no. 36, 229 p.
- Turner, C.H. 1960. River pollution prevention. *Jour. R. Soc. Hlth.* 80:403-408.
- Turner, C.H., E.E. Ebert, and R.R. Given. 1966. The marine environment in the vicinity of the Orange County Sanitation District's Ocean Outfall. *Calif. Fish Game* 52:28-48.
- Wheeler, A. 1970. Fish return to the Thames. *Sci. Jour.* 6(11): 28-33.

Table D14. Terminal Island Treatment Plant Sewage Bioassay. *Engraulis mordax* Embryos and Larvae, 96-hour Tests. Primary Dilution Zone (sewage boil) - Surface Water Dilutions.

Conc. (%)	Mar. 18 (N) (Mort.)	May 4 (N) (Mort.)	May 7 (N) (Mort.)	May 16 (N) (Mort.)	May 19 (N) (Mort.)	May 21 (N) (Mort.)	Aug. 12 (N) (Mort.)	Total N	Total Mortality	Survival (%)	Adjusted Survival (%)
100	5 5	10 10	5 5	10 10		10 10		40	40	0.0	0.0
90				10 10				10	10	0.0	0.0
80		10 10	5 5	10 10				25	25	0.0	0.0
75	5 5							5	5	0.0	0.0
70				19 19				10	10	0.0	0.0
60		10 9	5 5	10 10				25	24	4.0	4.4
50	5 0			10 10	10 10			25	20	20.0	21.9
40		10 2	5 5	10 10	10 10			35	27	23.9	26.2
30				10 10	10 7			20	17	15.0	16.4
25							10 4	10	4	60.0	65.6
20	5 0	10 0	5 2	10 1	10 0			40	3	92.5	101.4
15							10 1	10	1	90.0	98.7
10				10 0	10 0			20	0	100.0	109.6
5				19 0	10 1			20	1	95.0	104.2
1					10 0			10	1	90.0	98.7
0 (control)	5 0	10 1		10 2	10 1		10 0	45	4	91.2	100.0

Table D15. Way Street Outfall Bioassay. *Engraulis mordax* Embryos and Larvae, 96-hour Tests.
 Primary Dilution Zone (effluent boil) - Surface Water Dilutions.

Conc. (%)	18 March	14 April	20 April	23 April	28 April	16 May	19 May	27 July	Total N	Total Mortality	(% Survival)	Adjusted Survival
	(N) (Mort.)	(N) (Mort.)	(N) (Mort.)	(N) (Mort.)	(N) (Mort.)	(N) (Mort.)	(N) (Mort.)	(N) (Mort.)				
100	5 5	10 10		10 10					25	25	0.0	0.0
90		10 10		10 10					20	20	0.0	0.0
80		10 10		10 10					20	20	0.0	0.0
70		10 10		10 10	10 9				30	29	3.4	3.7
60		10 10		10 10	10 6				30	26	13.4	14.6
50	5 5	10 10		10 10	10 7	10 10	10 10		45	42	6.7	7.3
40			3 3	10 10	10 0	10 8	10 10	10 10	43	31	27.9	30.4
30		10 8	3 3	10 10	20 13	10 1	10 9	10 8	73	52	28.8	31.4
20		10 6	3 3	10 10	20 15	10 2	10 6	10 8	73	48	34.3	37.4
15					20 11		10 1	10 6	40	18	55.0	59.9
10	5 0	10 4	3 0	10 3	20 5	10 1	10 2	10 5	78	20	74.4	81.0
5					20 4	10 0	10 0	10 3	50	7	86.0	93.7
1					20 0	10 1	10 0	10 0	50	1	98.0	106.8
0 (control)		10 2	3 0	10 1	20 0	10 3	10 0	10 0	73	6	91.8	100.0

Table D16. Starkist Outfall Bioassay.
Engraulis mordax Embryos and Larvae, 96-hour Tests
 Primary Dilution Zone (sewage boil) Surface Water
 Dilutions

Conc. (%)	16 May (N) (Mort.)	19 May (N) (Mort.)	21 June (N) (Mort.)	28 July (N) (Mort.)	Total				% Adjusted Survival	
					Conc. (%)	N	Mortality	% Survival		
100										
90										
80										
70	10 10				70	10	10	0.0	0.0	0.0
60	10 10	10 10	10 10	10 10	60	40	40	0.0	0.0	0.0
50	10 10	10 10	10 10	10 10	50	40	40	0.0	0.0	0.0
40	10 10	10 5	10 10	10 10	40	40	35	12.5	12.5	12.5
30	10 10	10 4	10 10	10 10	30	40	34	15.0	15.0	15.0
20	10 10	10 3	10 9	10 9	20	40	31	22.5	22.5	22.5
15		10 1	10 6	10 6	15	30	13	56.7	56.7	56.7
10	10 10	10 1	10 1	10 1	10	40	13	67.5	67.5	67.5
5	10 6	10 0	10 0	10 0	5	40	6	85.0	85.0	85.0
1	10 4	10 0	10 0	10 0	1	40	4	90.0	90.0	90.0
0			10 0	10 0	0	20	0	100.0	100.0	100.0

Table D17. Hyperion and Terminal Island Treatment Plant
 Sewage Bioassay
Engraulis mordax Embryos and Larvae, 96-hour Tests
 Within Plant Dilutions, August 20, 1976

Conc. %	Hyperion Primary (N) (Mort.)	Hyperion Secondary (N) (Mort.)	Chlorinated (50mg/l) Hyperion Primary Secondary Mix (1:1) (N) (Mort.)	Terminal Island Treatment Plant Primary (N) (Mort.)
100		10 10		
90		10 10		
80		10 10		
70		10 10		
60		10 1		
50	10 10	10 0	10 10	10 10
40	10 10	10 0	10 10	10 10
30	10 10	10 0	10 10	10 10
20	10 10	10 0	10 10	10 10
15	10 10	10 1	10 10	10 10
10	10 7	10 0	10 10	10 6
5	10 6	10 0	10 0	10 1
1	10 3	10 1	10 1	- -
0	10 1	10 1	10 1	10 0

Table D18.

Terminal Island Treatment Plant Sewage Bioassay
Fundulus parvipinnis, 96-hour Tests

Primary Dilution Zone (sewage boil) Surface
Water Dilutions

Conc. (%)	1 July		5 July		8 July		Total Mortality		Adjusted Survival (%)	
	N	Mortality	N	Mortality	N	Mortality	N	Mortality	N	Mortality
100	10	0	10	0	10	0	30	0	100.0	111.1
0 (control)	10	1	10	1	10	1	10	1	90.0	100.0

Terminal Island Treatment Plant Sewage Bioassay
Cymatogaster aggregata, 96-hour Tests

Primary Dilution Zone (sewage boil) Surface
Water Dilutions

Conc. (%)	1 July		5 July		8 July		6 August		Total Total N Mortality	Survival (%)	Adjusted Survival (%)
	N	Mortality	N	Mortality	N	Mortality	N	Mortality			
100	1	0	1	0	1	0	3	1	6	66.6	66.6
90							3	0	3	100.0	100.0
80							3	0	3	100.0	100.0
70							3	0	3	100.0	100.0
0 (Control)							6	0	6	100.0	100.0

Table D19. Way Street Outfall Bioassay.
Fundulus parvipinnis, 96-hour Tests

Conc. (%)	Primary Dilution Zone (effluent boil) Surface Water Dilutions								Totals		
	10 June (N) (Mort.)	15 June (N) (Mort.)	25 June (N) (Mort.)	1 July (N) (Mort.)	9 July (N) (Mort.)	12 July (N) (Mort.)	28 July (N) (Mort.)	N	Mortality	(%) Survival	(%) Adjusted Survival
100	12 1	10 10	10 3	10 10	10 2	10 0	10 0	72	26	63.9	71.0
90		10 1	10 1				10 1	20	2	90.0	100.0
80		10 3	10 3				10 1	20	4	80.0	88.9
70		10 0	10 0				10 0	20	0	100.0	111.1
0 (control)	10 0	10 4	10 4		10 0		10 0	40	4	90.0	100.0

Way Street Outfall Bioassay.
Cymatogaster aggregata, 96-hour Tests

Conc. (%)	Primary Dilution Zone (effluent boil) Surface Water Dilutions						Totals	
	1 July (N) (Mort.)	12 July (N) (Mort.)	17 July (N) (Mort.)	6 August (N) (Mort.)	N	Mortality	(%) Survival	(%) Adjusted Survival
100	1 1	1 1	1 1	3 1	6	3	50.0	50.0
90		1 1	1 1	3 0	4	1	75.0	75.0
80		1 0	1 0	3 0	4	0	100.0	100.0
70		1 0	1 0	3 0	4	0	100.0	100.0
0 (control)		3 0	3 0	3 0	6	0	100.0	100.0

Table D 20. Starkist Outfall Bioassay.
Fundulus parvipinnis, 96-hour Tests

Primary Dilution Zone (sewage boil) Surface
Water Dilutions

Conc. (%)	21 June (N) (Mort.)	24 June (N) (Mort.)	10 July (N) (Mort.)	2 August (N) (Mort.)	Totals		Adjusted Survival (%)
					N	Mortality	
100	10 2	10 0	10 0	10 0	40	2	95.0
90	10 1	14 2	10 0	10 0	34	3	91.2
80	11 1	13 3	10 0	10 0	34	2	94.1
70	12 1	10 1	10 0	10 0	32	2	93.7
0 (control)					40	4	90.0

Starkist Outfall Bioassay.
Cymatogaster aggregata, 96-hour Tests

Primary Dilution Zone (sewage boil) Surface
Water Dilutions

Conc. (%)	25 June (N) (Mort.)	30 June (N) (Mort.)	6 July (N) (Mort.)	10 July (N) (Mort.)	16 July (N) (Mort.)	2 August (N) (Mort.)	Totals		Adjusted Survival (%)
							N	Mortality	
100	1 0	2 2	1 0	1 1	1 1	1 1	7	5	28.6
90					1 0	1 1	2	1	50.0
80					1 0	1 1	2	1	50.0
70					1 0	1 1	2	1	50.0
0 (control)							6	0	100.0

Table D21. Hyperion Treatment Plant Sewage Bioassay
Fundulus parvipinnis, 96-hour Tests within
 Plant Sample

Conc. (%)	1 July					9 July				
	Cumulative Mortality					Cumulative Mortality				
	N	24	48	72	96	N	24	48	72	96
100	10	0	0	0	0	10	0	0	0	0

Conc. (%)	Total N	Total Mortality	Survival (%)	Adjusted Survival (%)
100	20	0	100.0	111.1

PART E.

I. BIOASSAY INVESTIGATIONS OF THE IMPACT OF WASTES
ON THE COPEPOD *Acartia Tonsa*

II. MICROHETEROTROPHIC UPTAKE OF ORGANICS IN SEAWATER

by

John R. McConaugha
Research Associate
Harbors Environmental Projects
University of Southern California
Los Angeles, California 90007

I. BIOASSAY INVESTIGATIONS OF THE IMPACT OF WASTES
ON THE COPEPOD *Acartia Tonsa*

by

John R. McConaugha
Research Associate
Harbors Environmental Projects
University of Southern California

INTRODUCTION

The 96-hour bioassay test has become the standard method of determining the effect of any compound, or mixture of compounds, that is discharged into receiving waters. Although such tests do not consider other ecological parameters, they have been utilized in the present study to estimate what effect a change from primary treated domestic sewage to secondary treated sewage would have on the planktonic calanoid copepod *Acartia tonsa* population in the Los Angeles Harbor, and to evaluate the present impact of cannery wastes. *Acartia tonsa* is found extensively in the inner and middle harbor slips and channels in both Los Angeles and Long Beach, but although it is less prevalent in the outer harbor, near the waste outfalls it remains the numerically dominant species (Allan Hancock Foundation, 1975).

MATERIALS AND METHODS

Bioassay tests were carried out using: 1) primary treated waste from the Terminal Island Treatment Plant (TITP), 2) primary treated wastes from Hyperion Treatment Plant (HTP), 3) secondary treated HTP wastes, and 4) a mixture of primary and secondary HTP wastes. In addition, cannery waste samples were taken from *Harbors Environmental Projects University of Southern California*

the StarKist outfall and the Way Street Station, a combined canneries waste outfall. Effluent samples from TITP and Hyperion were collected inside the treatment plants in 5 gal polyethylene buckets, while the cannery effluents were obtained at the mouth of the outfall pipes. These effluents were considered to be 100 percent concentrations and were diluted with 0.45 μ filtered seawater to concentrations of 25, 15, 10, 5 or 1% prior to testing.

Specimens of *Acartia tonsa* were obtained from plankton tows taken in Los Angeles Harbor. The crude plankton was returned to the laboratory, where it was sorted and *A. tonsa* transferred to 0.45 μ Millipore filtered seawater.

All bioassay tests were conducted in 1 liter beakers containing 500 ml of the appropriate dilutions of effluent and covered with crystallizing dishes. Three replicates of 10 organisms per replicate were utilized.

Because *A. tonsa* is very small, oxygen introduced into the test containers creates bubbles and turbulence, which damages the organisms. For this reason oxygenation was not carried on in the test containers.

RESULTS

The results of the static bioassay tests are summarized in Table EI-1. When compared to the appropriate controls, TITP effluent and Hyperion secondary effluent were not significantly different at a concentration of 15%. Hyperion primary effluent and a mixture of primary and secondary effluent, with or without

chlorination (50 ppm), were lethal at a concentration of 1%. The estimated lethal dose with 50% mortality (LD50) was between 0.6% and 0.7% waste in each case, with no difference between the chlorinated and unchlorinated samples.

Waste from the StarKist cannery outfall was lethal to *A. tonsa* at concentrations of 10% or greater, while the Way Street cannery effluent was lethal at 5%. Although the exact cause of the observed mortality was not demonstrated, it was hypothesized that it might have been due to a rapid reduction in dissolved oxygen in the test samples. Oxygen measurements from one dilution series of waste from StarKist and the Way Street outfall (Table EI-2) indicated that there was a rapid drop in the dissolved oxygen content for dilutions of 5% or greater during the first 24 hours, followed by a gradual increase over the next 48 hours.

In an attempt to evaluate this hypothesis, the experimental procedure was modified to include a dilution series of effluent that had been aerated for 20 hours prior to the initiation of the experiment. The solution in each test container was replaced daily with freshly prepared dilutions made from a constantly aerated stock effluent (California State Water Resources Control Board, 1976). This technique did not produce a consistently high level of dissolved oxygen (DO) since the DO levels fell from approximately 7.5 ppm to 0.5 ppm over a 24-hour period, which was comparable with the DO of the non-aerated series. However, by replacing the effluents daily the organisms were not continuously exposed to low DO conditions but rather to a cyclical

situation of high to low DO over a twenty-four hour period.

The results of these experiments are summarized in Table EI-3. There was a noticeable increase in the survival rates for the aerated Way Street Station effluent, with 89% survival in 50% effluent as compared to 0% survival in 25% non-aerated effluent. However, there remains a lethal effect (0% survival) in the 75% effluent. Although there is a slight reduction in lethality of the StarKist effluent (Table EI-3) following aeration, the lethal effect remains high, with an estimated LD50 of 37% compared to an estimated LD50 of 8.5% for non-aerated effluent. The aerated TITP survival rate increased to 100% over the relatively high survival level (90%) in the non-aerated series of tests.

DISCUSSION

Because of the rapid drop in DO over a 24-hour period it is still not possible to exclude the effects of low DO (i.e. BOD and COD) totally on the observed survival rate of *A. tonsa*. However, because of the close approximation of the DO levels in the aerated and non-aerated effluents and the retention of some lethality in the higher concentrations these results suggest that there may be some undetermined toxic factor in the cannery effluents which is partially removed or altered by aeration. Although the reduced dissolved oxygen values masked the possibility of determining whether the wastes are in themselves toxic, it does not negate the relevance of the test to the field situation,

since dissolved oxygen values of the order of 1-3 ppm have been obtained in the immediate discharge area, especially during the summer months. Field data show, however, that, based on annual mean values, the BOD of the waste drops about 50% within a radius of 200 feet of the outfall pipe (Brewer, unpublished data). However, both BOD and DO fluctuate widely throughout the year (Table EI-4). Within 1000 feet (300 ± m) the BOD has declined to ambient levels. The drop in BOD and the increase in DO with distance from the cannery waste outfalls may be taken as an indicator of mixing in the initial dilution zone, as defined by the State Water Resources Control Board in Water Quality Policy for Bays and Estuaries.

The results of the TITP-Hyperion studies suggest that there would be little change in the effect of the effluent on *A. tonsa* in the event that the present primary-treated TITP effluent was changed to a secondary-treated effluent provided that the characteristics of the new effluent were similar to that presently being discharged by Hyperion TP.

Table EI-1. Static (Unoxxygenated) 96-hour Bioassay Tests of Hyperion and TITP Effluents

<u>Effluent</u>	<u>Concentration</u>	<u>% Survival</u>
0.45 μ filtered seawater	---	80.0%
TITP	15%	80.0%
	10%	82.8%
	5%	93.3%
	1%	86.6%
Hyp 2 ^o	15%	60.0%
	10%	77.1%
	1%	59.3%
Hyp 1 ^o	15%	0.0%
	10%	0.0%
	1%	1%
Hyp 1 ^o + 2 ^o	15%	0.0%
	10%	0.0%
	1%	26.6%
Hyp 1 ^o + 2 ^o + chlorine (50 ppm in 100% effluent)	15%	0.0%
	10%	0.0%
	1%	26.6%
Starkist	25%	0.0%
	10%	41.3%
	5%	50%
Way Street	25%	6.6%
	10%	37.5%
	5%	45%
	1%	61.6%
0.45 μ filtered seawater	---	78.8%

Table EI-2. Oxygen Depletion in Cannery Waste Samples
During 72 Hours.

Time dilutions:	StarKist			Way St. Cannery			Control
	5%	10%	20%	5%	10%	20%	
hours:							
0	3.5	1.5	0.3	5.2	4.6	4.3	5.2
24	0.7	0.4	0.3	4.5	2.6	1.1	6.2
48	0.7	0.5	0.4	5.5	4.5	4.1	5.8
72	3.0	0.9	0.3	5.6	5.4	4.6	7.3

Table EI-3. Comparison of Percent Survival of Aerated vs. Non-aerated Effluents from Los Angeles Harbor Receiving Waters.

StarKist (non-aerated)		StarKist (aerated)	
<u>Concentration</u>	<u>% Survival</u>	<u>Concentration</u>	<u>% Survival</u>
25%	0%	75%	0%
10%	0%	50%	0%
5%	91%	10%	78%

Way St. Station (non-aerated)		Way St. Station (aerated)	
<u>Concentration</u>	<u>% Survival</u>	<u>Concentration</u>	<u>% Survival</u>
25%	0%	75%	0%
10%	100%	50%	89%
5%	95%	25%	100%
		10%	100%

TITP (non-aerated)		TITP (aerated)	
<u>Concentration</u>	<u>% Survival</u>	<u>Concentration</u>	<u>% Survival</u>
25%	87%	75%	100%
10%	89%	50%	100%
5%	95%	25%	100%
		10%	94%

Table EI-4. Water Quality.

Tuna Research Foundation Monitoring

January through July, 1976

Dissolved Oxygen

Station	Mean DO at Surface	Range	Mean DO at Depth*	Range
1A	5.1	0.9 - 8.5	4.4	1.4 - 6.7
1B	6.1	1.6 - 8.2	6.8	4.6 - 9.2
1C	7.6	5.5 -10.3	7.0	4.5 -10.3
1D	8.3	5.8 -10.3	7.2	5.1 -10.2
2A	6.7	1.1 -11.0	5.1	0.6 - 6.9
2B	6.8	1.2 - 8.9	6.2	3.3 - 7.7
2C	7.6	2.3 -11.9	6.7	5.0 -10.2
2D	8.3	4.2 -11.8	6.8	2.5 - 9.8
3A	5.2	0.2 - 8.7	5.0	0.24- 9.0
3B	6.2	2.0 -11.1	4.7	0.1 - 8.5
3C	7.2	2.6 -11.6	6.3	3.8 - 7.8
3D	7.8	4.1 -10.6	6.9	4.4 - 8.4
4A	6.0	0.02- 8.4	4.7	1.3 -10.4
4B	6.4	2.0 - 8.5	6.4	3.8 - 9.1
4C	7.1	3.5 - 8.8	6.6	3.8 - 8.5
4D	8.1	3.8 -11.0	6.3	5.0 - 9.0

pH

Station	Mean DO at Surface	Range	Mean DO at Depth*	Range
1A	7.8	7.3 - 8.5	7.8	7.06- 8.37
1B	7.94	7.14- 8.52	7.99	7.38- 8.42
1C	8.05	7.48- 8.52	7.96	6.94- 8.33
1D	8.14	7.83- 8.63	8.04	7.6 - 8.57
2A	8.03	7.63- 8.73	7.93	7.36- 8.38
2B	8.04	7.33- 8.49	7.99	7.38- 8.44
2C	8.26	7.79- 9.52	8.04	7.41- 8.45
2D	8.18	7.61- 8.73	7.96	7.36- 8.56
3A	7.9	7.39- 8.59	7.94	7.22- 8.53
3B	8.04	7.45- 8.71	7.85	7.39- 8.36
3C	8.09	7.54- 8.76	8.03	7.41- 8.43
3D	8.13	7.56- 8.69	8.08	7.42- 8.51
4A	7.99	7.6 - 8.54	7.75	7.08- 8.36
4B	8.03	7.48- 8.46	7.95	7.37- 8.42
4C	8.14	7.55- 8.88	8.04	7.44- 8.51
4D	8.16	7.57- 8.65	8.00	7.44- 8.55

* Within 2 feet of the bottom.

Table EI-4 (continued)

Station	% Transparency			
	Mean DO at Surface	Range	Mean DO at Depth*	Range
1A	21	0 -81	52	20 - 94
1B	31	3 -92	51	7.6 -100
1C	42	15 -60	48	12 - 81
1D	48	37 -70	62	20 - 90
2A	28	6 -65	58	40 - 77
2B	34	18 -64	55	27 - 80
2C	43	16 -90	61	38 - 86
2D	59	28 -97	54	1 - 79
3A	17	5 -44	52	21 - 91
3B	27	2 -75	54	22 - 77
3C	39	12 -73	62	44 - 78
3D	49	30 -73	58	20 - 88
4A	39	6 -70	56	28 - 86
4B	42	10 -64	55	40 - 82
4C	47	28 -78	52	18 - 86
4D	53	27 -86	52	6 - 82

Station	BOD			
	Mean DO at Surface	Range	Mean DO at Depth*	Range
1A	29	3.2 -84.0	4.8	1.3 - 8.7
1B	13.3	3.6 -37.0	4.2	2.0 - 9.0
1C	6.6	1.9 -10.2	3.7	0.5 - 15.0
1D	5.7	2.3 -11.3	2.7	0.9 - 4.1
2A	16	2.1 -35	4.4	1.8 - 9.0
2B	12.0	5.5 -34.8	3.2	1.9 - 5.35
2C	7.7	3.0 -16	2.9	1.0 - 5.25
2D	5.0	1.75- 8.9	2.5	0.85- 3.8
3A	30.9	3.4 -78	4.8	1.4 - 11.0
3B	16.9	4.6 -58.5	4.1	2.1 - 7.1
3C	9.5	4.6 -32.25	3.4	1.35- 4.9
3D	5.4	2.7 - 8.2	2.9	1.25- 6.5
4A	21.1	2 -84	4.6	2.55- 10
4B	7.5	2.0 -17.25	4.1	1.95- 6.3
4C	5.9	1.9 -11.0	3.0	1.25- 4.15
4D	5.3	2.55- 8.6	2.7	0.95- 4.6

* Within 2 feet of the bottom.

II. MICROHETEROTROPHIC UPTAKE OF ORGANICS IN SEAWATER

by

John R. McConaugha
Research Associate
Harbors Environmental Projects
University of Southern California

INTRODUCTION

In the marine environment the utilization of dissolved organics by microorganisms through consumer (heterotrophic) pathways is important because of their role in nutrient recycling and detrital food chains. This aspect is especially important in areas that receive dissolved organic pollutants from domestic and industrial outfalls. Unfortunately these processes are poorly understood, especially in polluted waters. Williams and Gray (1970) stated that microorganisms in estuarine waters are capable of responding to a 100-fold increase in substrate concentration of organic substances within a 30-hour period. They further suggest that duration of any increased substrate concentration will be closely correlated with the substrate turnover time. However, Goulder (1976) was not able to correlate heterotrophic uptake with bacterial crops, suspended solids, or oxygen depletion and suggested that the change in heterotrophic activity may be related to changes in metabolic state or to the percentage of active bacteria.

This report presents the preliminary results of investigations of the microheterotrophic activity in the Los Angeles Harbor in the area receiving primary-treated sewage and cannery

Harbors Environmental Projects University of Southern California

effluent.

MATERIALS AND METHODS

Surface water samples were taken at eleven stations in the Los Angeles Harbor (Fig. EII-1), using a clean polyethylene bucket. Subsamples for the heterotrophic uptake experiments were then transferred to clean non-sterilized BOD bottles and placed in ice chests and returned to the laboratory. In addition to the subsamples for the heterotrophic uptake, samples were collected for primary productivity, chlorophyll α , nutrient and amino acid analysis. The physical parameters of temperature, salinity and dissolved oxygen were also measured for each station (Table EII-1).

In the laboratory the samples were filtered through a 202 μ mesh net and split into six 100 ml samples in heat-sterilized 125 ml reagent bottles. Three of these samples received 0.4 μ Ci of ^3H -glucose while the remaining 3 bottles received .048 μ Ci of a mixture of 5 uniformly labelled ^{14}C amino acids. One sample in each series received 2-5 ml of butanol and served as a control. All samples were incubated in the dark for a period of 6-18 hours. Following incubation a 50 ml sample was filtered through a glass fiber filter. The wet filters were placed directly into scintillation vials containing 10 ml of Aquasol. Following a minimum period of 24 hours, samples were counted in a Beckman liquid scintillation counter at an efficiency of 62.6% for ^{14}C and 35.9% for ^3H . Counts per minute (CPM) were corrected

for efficiency and converted to turnover time (S/V) by the equation $S/V=t/f$ where S is the substrate concentration, V is the uptake velocity, t is time, and f is the fraction of added tracer taken up in time t (Azam and Holm-Hansen, 1976).

The amino acid mixture contained the 5 major amino acids found in the main cannery effluent (Chamberlain, 1975). The composition of the mixture (by radioactivity) was: L-Glutamic acid, 26.8%; L-Glycine, 21.6%; L-Aspartic acid, 18.6%; L-Alanine, 16.5%; and L-Lysine, 16.5%.

RESULTS

Table E II-1 presents the amino acid and glucose turnover rates in days measured at 11 stations on 3 Aug. 1976. The amino acid activity at the StarKist outfall was the lowest, with a turnover time of 7.5 days. This station also had the highest protein concentration (Table E II-1), This, however, does not totally explain the rather slow turnover rate at station 5 since the Way Street Cannery outfall area also had high protein concentrations but had a turnover rate comparable to the other stations. The glucose turnover rates are opposite to those for amino acids, with the StarKist outfall having a turnover rate of 2.6 days while the remaining harbor stations had turnover rates ranging from 3.1 to 6.6 days; station 1 outside the breakwater was fastest with a rate of 2.5 days. Analyses are presently being conducted to determine the ambient substrate levels of amino acids and glucose present at each station.

With this data it will be possible to calculate uptake rate (V) at each station. It should then be possible to determine if the differences in observed turnover time are due to substrate levels or to possible differences in the number of organisms or metabolic activity of the heterotrophic population.

DISCUSSION

The exact composition of any microheterotrophic population is unknown. However, size distributions indicate that greater than 50% of heterotrophic activity is less than 1.2 μ in size and presumably bacterial (Williams, 1970). Assuming that the major portion of the heterotrophic activity was bacterial, Williams and Gray (1970), utilizing bacterial enzyme kinetics, suggested that the observed lag period (25-30 hr.) between the addition of high amino acid concentration and uptake by heterotrophic organisms was due to growth and enzyme induction. Although the Los Angeles Harbor continually receives discharges from both the canneries and TITP the quantity and quality is highly variable.

Therefore growth rates and induction may be factors in the utilization of these wastes. Further study is needed to determine if these are important factors in the harbor ecosystem. Information is also needed on the carrying capacity of harbor waters for microheterotrophs before a maximum assimilation capacity (μ g C/l) can be calculated.

Table E II-1. Microheterotrophic Turnover Rates, August 3, 1976.

<u>CTP Station Number</u>	<u>Amino Acid Uptake (S/V days)</u>	<u>Glucose Turnover (S/V days)</u>	<u>Protein mg/l</u>	<u>Dissolved Oxygen (ppm)</u>
1	1.5	2.5	0.6	7.6
2	2.8	6.5	1.2	7.1
3	1.6	5.9	4.7	4.6
4	2.2	6.0	8.5	2.1
SK 5	7.5	2.6	84.2	2.4
WS 6	2.0	4.7	53.4	2.1
TITP 7	1.6	3.1	12.3	5.7
8	1.2	3.6	17.2	2.3
10	2.5	6.6	7.1	3.1
11	1.2	5.6	12.2	4.2
12	1.3	4.9	0.6	9.1

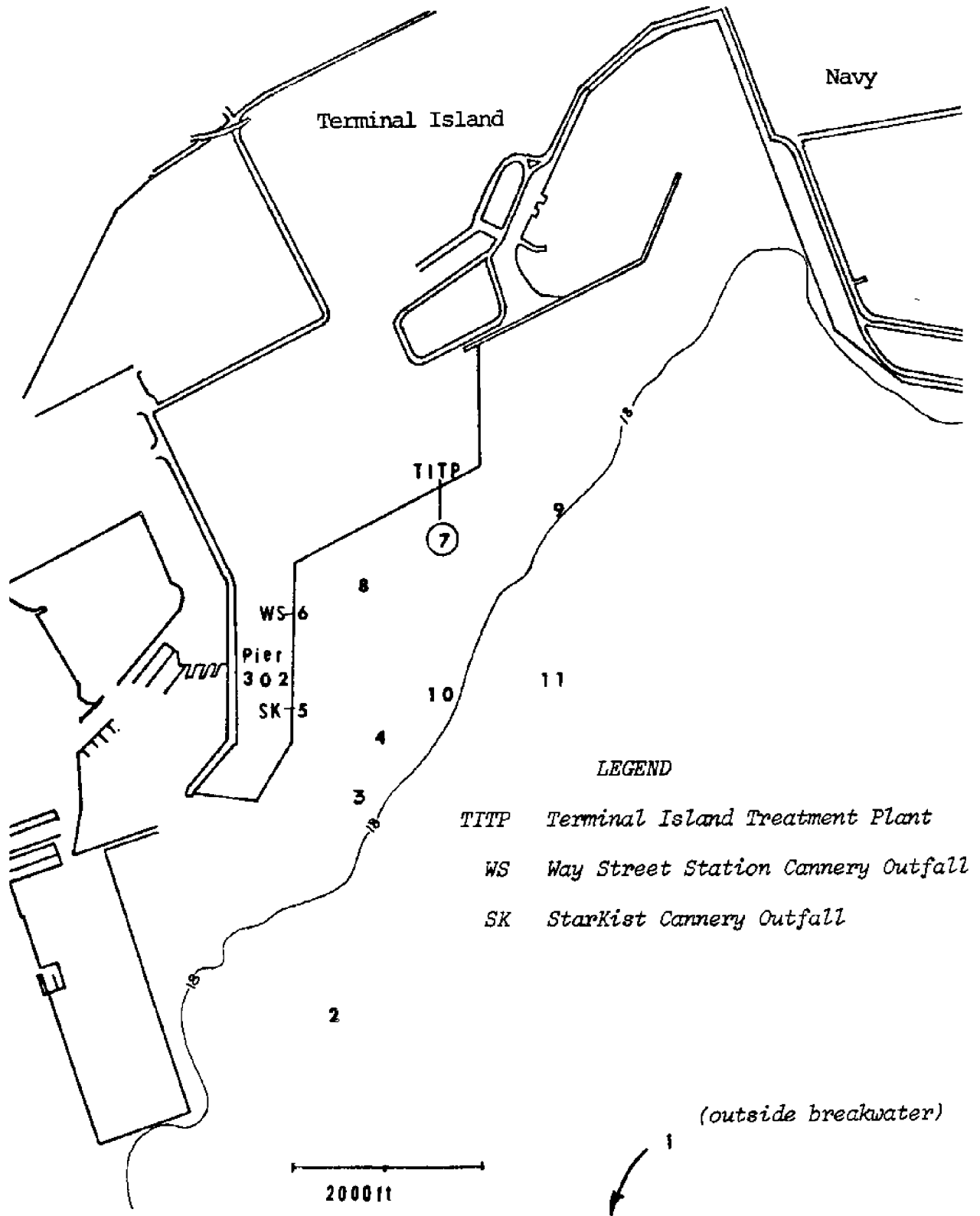

Figure E 1. Cannery/Treatment Plant (CTP), Special Stations, 1976

LITERATURE CITED

- Allan Hancock Foundation. 1975. Environmental investigations and analyses for Los Angeles-Long Beach Harbors, Los Angeles, California. A report to the U.S. Army Corps of Engineers, Los Angeles District. Harbors Environmental Projects, Univ. So. Calif. 552 p.
- Azam, F., and O. Holm-Hansen. 1973. Use of tritiated substances in the study of heterotrophy in seawater. *Marine Biology* 23:191-196.
- Chamberlain, Dilworth W. 1975. The role of fish cannery waste in the ecosystem. In *Marine Studies of San Pedro Bay, California. Part 8.* Allan Hancock Foundation and Sea Grant Program, Univ. So. Calif. 1-22.
- Goulder, R. 1976. Relationships between suspended solids and standing crops and activities of bacteria in an estuary during a neap-spring-neap tidal cycle. *Oecologia* 24:83-90.
- Williams, P.J. LeB. 1970. Heterotrophic utilization of dissolved organic compounds in the sea. I. Size distribution of population and relationship between respiration and incorporation of growth substrates. *J. Mar. Biol. Ass. U.K.* 50:859-870.
- Williams, P.J. LeB., and R.W. Gray. 1970. Heterotrophic utilization of dissolved organic compounds in the sea. II. Observations on the responses of heterotrophic marine populations to abrupt increase in amino acid concentration. *J. Mar. Biol. Ass. U.K.* 50:871-881.

Part G.

IMPACT OF DISCHARGES FROM THE MAIN CANNERY, STAR KIST
AND THE TERMINAL ISLAND WASTE TREATMENT PLANT
ON THE ECOLOGY OF OUTER LOS ANGELES HARBOR

by

Ray R. Emerson, Ph.D.
Harbors Environmental Projects
University of Southern California
Los Angeles, California 90007

IMPACT OF DISCHARGES FROM THE MAIN CANNERY, STARKIST
AND THE TERMINAL ISLAND WASTE TREATMENT PLANT
ON THE ECOLOGY OF OUTER LOS ANGELES HARBOR

by

Ray R. Emerson, Ph.D.

INTRODUCTION

At present the Way Street Station and the Star Kist outfall are discharging organic fish cannery wastes into Los Angeles Harbor. Some preliminary digestion and screening are done prior to discharging; however, the impact of these discharges on the receiving waters has not previously been determined. The organic material comprising a major portion of both discharges can be utilized to some extent by the variety of indigenous marine organisms representing the full range of trophic levels within the harbor. The question arises as to how much of this "organic soup" can be discharged to the benefit of the marine communities and what the alternatives might be for handling the excess. Recent regulatory mandates have offered the alternative of demonstrating the "bioenhancement" due to their discharges to the canneries or having the wastes processed through the adjacent Terminal Island Waste Treatment Plant (TITP).

In addition, the TITP facility has been directed by the State Water Resources Control Board to demonstrate an "enhancement" effect from discharging secondary treated waste, within the same area of the harbor. If such an effect cannot be demonstrated to the satisfaction of the Board, the discharge

may have to be relocated outside the Harbor.

The impact of the secondary treatment process, which is presently required for the new TITP facility, is a difficult problem to assess. It has not yet been determined whether this process will include continuous or periodic chlorination such as is presently being done at the Hyperion Water Treatment Plant. Chlorine, with its ability to form chemical complexes with organic materials, represents the single greatest potentially toxic constituent of the TITP secondary waste.

The emphasis of this part of the investigation was 1) to determine the impact of the present Way Street Station, Star Kist and TITP discharges; 2) to evaluate the impact of the proposed secondary treatment, and 3) to estimate the extent of "bioenhancement" stemming from these discharges to the variety of marine organisms presently within the existing harbor ecosystem.

A series of experiments were conducted to determine:

1. The effects on certain marine invertebrates of the wastes in receiving waters, in various concentrations which simulate dilutions under field conditions.
2. The effect of secondary waste treatment on certain marine invertebrates.
3. The effects of wastes in the receiving waters on primary productivity.
4. The "bioenhancement" or nutrient contribution of the waste discharges to a variety of marine organisms.

I. IMPACT OF CANNERY AND TITP WASTES IN THE RECEIVING WATERS
ON CERTAIN MARINE INVERTEBRATES

Two species of polychaetous annelids, *Ophryotrocha puerilis* and *Capitella capitata* were used as test organisms. *Ophryotrocha puerilis* occurs commonly throughout Los Angeles Harbor and is a member of the "fouling" community, those organisms which attach to pier and dock pilings. *Capitella capitata* is also commonly found throughout much of the Harbor and thrives in the soft silty substrate of the Harbor benthos. Both of these species have been used routinely as bioassay organisms (Akeson, 1970; Reish and Barnard, 1960; Emerson, 1974).

MATERIALS AND METHODS

Effluent from each of the three harbor discharges was collected in 5 gallon plastic buckets, returned to the laboratory and stored at 6° C. Bioassay procedures consisted of preparing a replicate series of dilutions from the discharge sample. Five organisms were added to each test chamber which consisted of 15 ounce jars and monitored for at least 96 hours. Survival and lethal effects were recorded, in addition to sublethal effects, as determined by the number of egg cases produced by *O. puerilis* and by brooding behavior in *Capitella capitata*.

The lethal dose for 50 percent (LC₅₀) was determined for each series of tests, and a reproductive index (RI₅₀) was determined for *O. puerilis*. The RI₅₀ is similar to the LC₅₀, except that it indicates the effluent concentration at which 50% of the

reproductive potential of the species has been curtailed.

Prior to each bioassay a sample of the discharge was frozen for later analysis of total protein content. Total protein was measured as an indication of the organic or nutrient load of the discharge sample and is reported in Part C (Bever).

RESULTS

Preliminary monitoring of a range of discharge concentrations revealed that the dissolved oxygen levels in static test chambers without the test organisms varied, with some decreasing and some increasing over a 72-hour period. The dissolved oxygen level within the vicinity of the discharges is believed to be one of the primary limiting factors to marine organisms. Demand on the dissolved oxygen levels within the discharge areas was greatest in the Way Street and StarKist effluents, which is indicative of their high organic content. Providing laboratory aeration to the test chambers brought all of the respective dilutions up to about 5.0 ml/l of DO₂.

The organic load of the discharge, as indicated by mg protein/liter was determined over a period of time from June 23, 1976 to August 3, 1976 (Table F1). The StarKist discharge was highest in organic content, ranging from 39.9 to 84.2 mg protein/liter. The Way Street discharge ranged from 27.4 to 53.4 mg protein/liter. The TITP discharge was lowest in organic content, ranging from 12.2 to 18.4 mg protein/liter.

Table F1. Total Protein Content of Discharges Surveyed.

Discharge	Total Protein in mg/liter			Mean	Range
	1976 6/23	Collection 7/8	Dates 8/3		
StarKist	42.3	39.9	84.2	55.5	39.9-84.2
Way Street	35.5	27.4	53.4	38.8	27.4-53.4
TITP	18.4	12.2	12.3	14.3	12.2-18.4

Static 96-hour bioassays with *Ophryotrocha puerilis* indicated that the TITP discharge was least inhibitory of the three discharges, but a 96-hour LC₅₀ could not be determined since mortality at 100% concentrations was less than 50% (Table F2a). However, the sublethal effects produced an RI₅₀ at a 48% concentration of the TITP discharge.

The StarKist discharge was the most inhibitory, with an LC₅₀ of 43% for *O. puerilis* (Table F2) and an LC₅₀ of 58% for *Capitella capitata* (Table F3a). Reproduction, as determined by the number of egg cases produced, was terminated between 25 and 50% concentrations of the discharge for *Capitella capitata*.

The Way Street discharge produced an LC₅₀ of 60% concentration for *O. puerilis* and an LC₅₀ of 80% concentration for *C. capitata*. Reproduction was terminated between 25 and 50% concentrations (RI₅₀ 15%) for *O. puerilis* and between 10 and 25% for *Capitella capitata*.

In an attempt to determine the limiting effect of low dissolved oxygen levels in static bioassays, another series of tests were conducted with *O. puerilis* and *C. capitata* at various levels

Harbors Environmental Projects University of Southern California

of dissolved oxygen. Intermittent aeration of the TITP and Way Street discharges did not appreciably improve survival or the number of egg cases produced by *O. puerilis* (Table F2b). However, intermittent aeration of the StarKist discharge did improve survival and the number of egg cases produced. Dissolved oxygen levels of the non-aerated TITP discharge ranged from 5.2-7.0 ml/l. The non-aerated Way Street and StarKist discharges had respectively lower ranges of 1.1-5.5 ml/l and 0.3-2.6 ml/l. Intermittent aerated Way Street and StarKist discharges ranged from 3.2-6.4 ml/l and 2.5 and 5.6 ml/l respectively over the 96 hour period.

Capitella capitata was less sensitive to dissolved oxygen levels than *O. puerilis*. Complete survival of *C. capitata* occurred in all TITP discharge concentrations with dissolved oxygen levels ranging as low as 5.2 ml/l in the non-aerated tests (Table F3b). The Way Street discharge levels of dissolved oxygen ranged as low as 1.1 ml/l and also yielded complete survival in all test concentrations. Levels of dissolved oxygen of the StarKist discharge ranged as low as 0.3 ml/l in the non-aerated tests. Survival was not appreciably affected at these lower dissolved oxygen levels. Both intermittent and continuous aeration of the StarKist discharge produced correspondingly greater mortality in the higher concentrations. Complete mortality occurred in the 100% and 75% concentrations where dissolved oxygen levels averaged from 7.1-7.3 ml/l. It is herein suggested that vigorous aeration of the StarKist discharge may produce a toxic constituent to *Capitella capitata* which is presently undefined.

Table 2a. Static Bioassays Using *Ophryotrocha puerilis*

Numbers are means of replicate tests at end of 96 hours
(Five organisms per test per concentration)

Discharge	Concentration (%)	No. of Survivors (out of five)	No. Egg Cases
TITP	100	3	0
	75	4.5	1
	50	5	3.5
	25	4	2.5
	10	4	4
	5	4.5	2.5
	1	5	4
	LC ₅₀ >100%		
RI ₅₀ 48%			
Way Street	100	1	0
	75	2.5	0
	50	3.5	0
	25	4	1.5
	10	4	2.5
	5	5	3.5
	1	5	3
	LC ₅₀ 60%		
RI ₅₀ 15%			
Starkist	100	0	0
	75	0	0
	50	4.5	0
	25	4.5	2.5
	10	4	2.5
	5	4	4.5
	1	5	3
	LC ₅₀ 43%		
RI ₅₀ 33%			
Controls(4)	0	5	3.25

Table F2b. Static 96 Hour Bioassay Tests Using *Ophryotrocha puerilis* with varying levels of dissolved oxygen.

Number of survivors and number of egg cases are means of replicate tests (5 organisms/test).

Dissolved oxygen (ml/l) concentrations are means determined at 24 hour intervals.

Concentration		Intermittent Aeration*			No Aeration		
		No. of Survivors	No. Egg Cases	DO	No. of Survivors	No. Egg Cases	DO
TITP	100	3.5	0	5.9	5	0	5.2
	75	5	1	6.1	5	1	5.4
	50	4.5	3	6.5	5	1.5	5.9
	25	5	2.5	6.9	5	3	6.5
	10	4.5	2	7.4	5	4.5	7.0
Way St.	100	4	0	3.2	4	1.5	1.2
	75	5	3	3.6	4.5	2	1.1
	50	5	.5	4.0	5	2	1.6
	25	3.5	2	4.6	5	.5	3.3
	10	4.5	2	6.4	5	1.5	5.5
Star-kist	100	3.5	0	2.5	0	0	0.3
	75	4	0	2.8	0	0	0.3
	50	5	.5	3.2	1.5	0	0.3
	25	5	2.5	4.2	4.5	1	0.7
	10	5	2.5	5.6	5	2	2.6
Controls		5	2.5	7.2	5	4	6.8

* Test solutions were prepared daily from stock solutions undergoing continuous aerations.

Table F3a. Static Bioassays using *Capitella capitata*.

Numbers are means of replicate tests at end of 96 hours. (Five organisms per test per concentration)

Discharge	Concentration (%)	No. of Survivors (out of five)	No. Egg Cases
TITP (LD ₅₀ 65%)	100	1	0
	50	3	0
	25	5	2
	10	5	1
	1	5	1
Way Street (LD ₅₀ 80%)	100	2	0*
	50	5	0*
	25	5	0*
	10	5	1
	1	5	1
Starkist (LD ₅₀ 58%)	100	0	0*
	50	4	0*
	25	5	0*
	10	5	1
	1	5	1
Controls (4)	0	5	1

* Eggs were present in tube, but had been abandoned by adult.

Table F3b. Static 96 Hour Bioassay Tests using *Capitella capitata* with varying levels of dissolved oxygen.

Number of survivors and number of egg cases are means of replicate tests (5 organisms/test).

Dissolved oxygen (ml/l) concentrations are means determined at 24 hour intervals.

Concentration		Continuous Aeration		Intermittent Aeration*		No Aeration	
		No. of Survivors	DO	No. of Survivors	DO	No. of Survivors	DO
TITP	100	5	7.5	5	5.9	5	5.2
	75	5	7.6	5	6.1	5	5.4
	50	5	7.6	5	6.5	5	5.9
	25	5	7.9	5	6.9	5	6.5
	10	5	7.6	5	7.4	5	7.0
Way. St.	100	5	7.3	5	3.2	5	1.2
	75	4	7.4	5	3.6	5	1.1
	50	5	7.4	5	4.0	5	1.6
	25	5	7.6	5	4.6	5	3.3
	10	5	7.6	5	6.4	5	5.5
Star-kist	100	0	7.1	3	2.5	4	0.3
	75	0	7.3	3	2.8	3	0.3
	50	3	7.4	3	3.2	5	0.3
	25	5	7.5	3	4.2	5	0.7
	10	5	7.4	3	5.6	5	2.6
Controls		5	7.5	5	7.2	5	6.8

* Test solutions were prepared daily from stock solutions undergoing continuous aeration.

DISCUSSION

The greater reproductive sensitivity of the *Capitella capitata* over *O. puerilis* may be explained by the behavior of the organisms. Newly hatched larvae of *C. capitata* remain on the bottom of the test chamber, while *O. puerilis* larvae and adults display greater mobility and may migrate to the surface of the test solution where oxygen levels are probably higher. Mobile species of marine organisms living within the harbor would have a greater likelihood of surviving under low dissolved oxygen conditions.

The results of these bioassays represent the combined impacts of the discharges with respect to possible toxic components, chemical and biological oxygen demand, and freshwater input into a saline environment.

No attempt was made in this study to determine separate thresholds of response of the test organisms to dissolved oxygen (DO) levels.

Previous studies with both *Ophryotrocha puerilis* and *Capitella capitata* have shown that continuous aeration of contaminated waste waters collected from Los Angeles Harbor showed insignificant lethal responses by the test organisms within a 96-hour period (Emerson, 1976). The cannery discharges, which consist primarily of an organic fraction, are primarily wastes with high oxygen demands. This may produce lethal responses due to the lower dissolved oxygen levels. This was a primary concern in the design of these bioassays.

The effluent from the TITP facility, with a lower organic content (Table F1), places less demand upon the dissolved oxygen of the receiving waters but has a greater potential for containing toxic constituents such as heavy metals, pesticides and PCB's. The concentration levels of the toxic constituents within a sample of the effluent are too low to represent lethal levels within the time frame of a standard 96-hour bioassay, as prescribed by the State Water Resources Control Board (Kopperdahl, 1976).

Levels of toxic components within the existing TITP primary discharge may be altered by the aeration of discharge samples during bioassays, altering the lethal response of organisms due to changes in chemical speciation and solubilities (Chen, personal communication). The problems of conducting 96-hour bioassays using a variety of separate contaminants at a series of dissolved oxygen levels put this approach beyond the scope of the present study, but it has been attempted recently with limited success (Lu, 1975).

Bioenhancement or Biostimulation

The "enhancement" nature of the receiving waters can be determined by examining the reproductive potential or number of egg cases produced by *O. puerilis* within a 96-hour period. The physiological condition of stock cultures maintained in the laboratory for extended periods of time changes in response to culture stock density, available food and changing quality of the culture water within a closed system. Some of these factors

Harbors Environmental Projects University of Southern California

may have contributed to the variability in number of egg cases produced by *O. puerilis* controls which ranged from means of 3.0 (Tables F4 and F5) to a mean of 5 (Table F6). When considering the series of experiments using *O. puerilis*, comparisons of the reproductive potential were made between test and control groups within each experiment to minimize the physiological variability of the organisms.

The number of egg cases produced by *O. puerilis* in concentrations of the cannery discharge (Table F2) exceeded the controls cultured in seawater collected from outside the harbor at station A1 (Angels Gate). Control groups in this series of tests produced an average of 3.25 egg cases.

The number of egg cases produced by *O. puerilis* in dilutions of the TITP discharge were highly variable and ranged from 3.5 in a 50% concentration to 4.0 in a 1% concentration (Table F2). A greater number of egg cases were produced in dilutions of 50%, 10% and 1%.

In subsequent experiments to determine the effects of secondary treatment the control group of *O. puerilis* produced 4.5 egg cases (Table F6). The number of egg cases produced in 1%, 5% and 10% concentrations of the Hyperion primary treated waste averaged 5.0 egg cases which exceeded the control group.

II. EFFECTS OF SECONDARY WASTE TREATMENT AND CHLORINATION ON SELECTED INVERTEBRATES

One of the major purposes of converting the existing discharges to secondary treatment is to reduce the biological oxygen demand (BOD) on the receiving waters. High oxygen demand (biological or chemical) causes reduced dissolved oxygen levels which are not well tolerated by the vast majority of marine organisms. While secondary waste treatment can reduce the BOD of the receiving waters significantly, this advantage may be more than offset by the periodic or continuous input of chlorine as a disinfectant in the secondary treatment process.

The purpose of this aspect of the study was to compare the toxicity of the TITP primary, Hyperion primary, and Hyperion secondary waste water in an attempt to project the impact of secondary treated waste water discharged into the harbor, and to compare the effects of chlorination which will be included in the secondary treatment process for public health reasons.

MATERIALS AND METHODS

Samples of waste water were collected from inside the Hyperion and TITP facilities in 5-gallon plastic buckets. Samples of chlorinated Hyperion secondary treated waste water were not available, as chlorination was not being carried out at Hyperion during this study. Chlorinated waste water was prepared by adding sodium hypochlorite (NaOCl) to a mix of Hyperion primary and secondary in a ratio of 70:30. The

primary-secondary (70:30) mix is typically the proportion of the waste water which would undergo periodic chlorination at the Hyperion facility.

Test organisms were exposed to a series of dilutions of each waste water treatment facility for a period of 96 hours. Replicate tests were carried out using five organisms in each test chamber. Tests were conducted to determine the sensitivity of the test organisms to changes in salinity and to chlorination, in the absence of the waste water fraction.

RESULTS

In order to assess the effects of salinity changes and chlorination in secondary treatment, these parameters were tested separately with *Ophryotrocha puerilis*. Sodium hypochlorite (NaOCl), the major compound used in the chlorination phase of some secondary treatments, was prepared in a series of dilutions with fresh seawater which had been filtered through 0.45 μ Millipore filters.

The results of the 96-hour static bioassay tests indicated that lethal levels of NaOCl are between 5 and 50 ppm for *O. puerilis* (Table F4). The number of egg cases produced, an indication of reproductive capacity, was reduced at concentrations of 5-0.5 ppm, as compared with controls.

Samples of the discharges collected from the receiving waters are lower in salinity; thus the dilutions determined the salinity levels used in the test procedures and could not

Table F4. Static Bioassays using *Ophryotrocha puerilis* to Determine the Toxicity of Sodium Hypochlorite.

Numbers are means of replicate tests.

NaOCl (ppm)	No. Organisms (96 hours)	No. Egg Cases (96 hours)	No. Egg Cases (144 hours)	No. Hatched
50	0	0	0	0
5	5	1.5	4.5	1
0.5	5	4.5	5	3
0.05	5	2	6	2.5
Controls (2)	5	3	7	2.5

be tested separately (Table F5). Possible synergistic effects of chlorination and reduced levels of salinity have not been determined at this time. *O. puerilis* was unable to survive within a salinity range of 16.4 to 24.6 parts per thousand. Reproduction was adversely affected in salinities between 24.6 and 29.5 parts per thousand.

To determine the effects of the proposed secondary treatment of the TITP effluent comparisons were made with the Hyperion primary, secondary and a chlorinated mix of primary and secondary effluent (Tables F6,F7). The Hyperion primary was more lethal to both *O. puerilis* and *C. capitata*. Both species showed 100% survival in 10% Hyperion primary. In Hyperion secondary *O. Puerilis* showed 100% survival in a 25% concentration of the discharge, while *C. capitata* showed complete survival in 50% concentration of the Hyperion secondary treated sewage.

The TITP primary was less toxic than the Hyperion primary for both test organisms. This may be attributed to the greater organic load of the Hyperion discharge as determined by total organic carbon (148 ppm), while the TITP discharge was 54 ppm.

The chlorination of the Hyperion mix (primary:secondary) produced a greater lethal response than any of the other discharges tested (Table F6). Although the organic load (total organic carbon) of the Hyperion mix was 67 ppm and well within the range of the primary and secondary Hyperion discharges, it was the most toxic to *O. puerilis*, with complete survival

Table F5. Static Bioassays using *Ophryotrocha puerilis* to Determine the Sensitivity to Salinity.

Numbers are means of replicate tests.

Freshwater Salinity (%)	Salinity (‰)	No. Organisms (96 hours)	No. Egg Cases (96 hours)	No. Egg Cases (144 hrs.)	No. Hatched (144 hr.)
75	8.2	0	0	0	0
50	16.4	0	0	0	0
25	24.6	5	2.5	3.5	0
10	29.5	5	2.5	5.5	2.5
5	31.2	5	2	6	1.5
Controls (2)	32.8	5	3	5	2

Table F6. Static Bioassays using *Ophryotrocha puerilis* comparing relative lethality of Hyperion Primary, Hyperion Secondary, Hyperion Primary + secondary + chlorination, and TITP Primary.

Numbers are means of replicate tests of five animals each.

Concentration (%)	Salinity (%)	No. Survivors (96 hours)	No. Egg Cases (96 hours)
TITP Primary	50	16.5	0
	25	24.5	1
	10	29.5	3
	5	31.2	5
	1	32.0	5
Hyperion Primary	50	16.5	0
	25	24.5	0
	10	29.6	5
	5	31.2	5
	1	31.8	5
Hyperion Secondary	50	16.5	0
	25	24.5	5
	10	29.6	5
	5	31.2	5
	1	31.8	5

Concentration (%)	Chl. (ppm)	Sal. (%)	No. Surv. (96 hrs.)	No. Egg Cases (96 hours)
Hyperion Primary + Secondary + Chlorination (50 ppm)	50	16.5	0	0
	25	24.5	0	0
	10	29.6	0.5	0
	5	31.2	4.5	2
	1	31.8	5	2.5
Controls (4)	0.05	32.8	5	4.5

Table F7. Static Bioassays using *Capitella capitata*, utilizing Discharges from Hyperion Primary, Hyperion Secondary, Hyperion Primary + secondary + chlorination, and TITP Primary Waste Treatment.

Numbers are means of replicate tests (five organisms per test per concentration).

Concentration (%)	No. of Survivors - 96 hours			
	TITP Primary	Hyperion Primary	Hyperion Secondary	Hyperion Prim.+ Second. + Chl.
50	0	0	5	0
25	1	0	5	4
10	5	5	5	5
5	5	5	5	5
1	5	5	5	5
Controls (4)	5	5	5	5

only at a concentration of 1% of the discharge. *C. capitata* was less sensitive to the chlorinated discharge with complete survival occurring in 10% concentrations.

DISCUSSION

In general, chlorine, a powerful oxidant in water, may be present as free chlorine in the form of hypochlorous acid or hypochlorite ion or both (Brungs, 1973). Free available chlorine is seldom found in secondary treated waste water, since it is usually added in lesser quantities than the chlorine demand before discharge into the receiving waters (McKee and Wolf, 1963). The resulting compounds are primarily chloramines and a variety of chloro-derivates. The derivatives are a consequence of the composition of the waste waters and may result in toxic compounds normally not found in the discharge (Allen, et al., 1946; Carlson, 1972; Hayatsu, et al., 1971).

The toxicity of chlorine to marine organisms will not depend alone upon the amount of chlorine added in the secondary waste treatment process, but on the concentration and composition of chlorine compounds already in the receiving waters. However, the toxicity of free chlorine has been considered of the same order of magnitude as that of chloramines and a measure of residual chlorine is a good indication of chlorine toxicity (Dudoroff and Katz, 1950; Merkens, 1958).

The toxicity of the chlorinated waste material to *O. puerilis*, as discussed above, has also been demonstrated in marine estuarine and freshwater environments (Hirayama and Hirano, 1970; Brook and Baker, 1972).

Harbors Environmental Projects University of Southern California

III. THE IMPACT OF CANNERY WASTES ON PRIMARY PRODUCTIVITY IN THE RECEIVING WATERS

Phytoplankton constitutes the major trophic level upon which the variety of marine herbivores and carnivores are directly or indirectly dependent. The canneries discharge high levels of organics which are acted upon by bacteria in the receiving waters, to produce an abundance of nutrients important for phytoplankton productivity. These nutrients include nitrates, nitrites, phosphates and ammonia. The effects of these nutrients on phytoplankton are varied. Insufficient levels are inhibitory to phytoplankton success; possible inhibitory effects of excessive levels are not sufficiently documented in the literature on phytoplankton. Microbials break down the organic load, but possible inhibitory effects of the microbials on the phytoplankton are not understood at present.

The purposes of this portion of the study were: 1) to determine the amount of primary productivity occurring in the discharge area and the efficiency with which nutrient assimilation was occurring, and 2) to determine the potential support levels or growth response of these high nutrient concentrations to a primary producer-organism cultured under controlled laboratory conditions.

MATERIALS AND METHODS

A series of eleven stations (CTP 1-11) were established to sample the concentration gradients of the three discharges on
Harbors Environmental Projects University of Southern California

the northern margin of the major water circulation gyre within the outer harbor (Figure 1). The temperature, salinity, and dissolved oxygen present at each station were determined with the Martek probe from a small boat (Table 8). Water samples were collected from each of the stations in 300 ml DO bottles, refrigerated and returned to the laboratory.

Primary productivity determinations were made using a modification of the isotopic ^{14}C carbon method, first described by Nielsen (1952). Duplicate clear and black plastic-coated 125 ml, glass-stoppered bottles were filled with water from the sampling station. To each was added a known quantity of radioactive carbon as carbonate or bicarbonate. The bottles were incubated at ambient seawater temperature under controlled illumination for three hours. The contents of the bottles were filtered through Millipore AA filters, and the cells containing the assimilated radioactive carbon were retained on the filters. The proportion of assimilated carbon was determined. The data are reported as milligrams of carbon fixed, per hour of incubation, per cubic meter of water sampled.

Standing crop determinations were made by measuring the quantity of chlorophyll *a* present per liter of water sampled. A known volume of water was filtered through Millipore HA filters and the pigments were extracted into 90% acetone from the cells retained on the filter. The pigments in the extract were then determined spectrophotometrically. The equations of Strickland and Parsons (1968) were used to calculate pigment

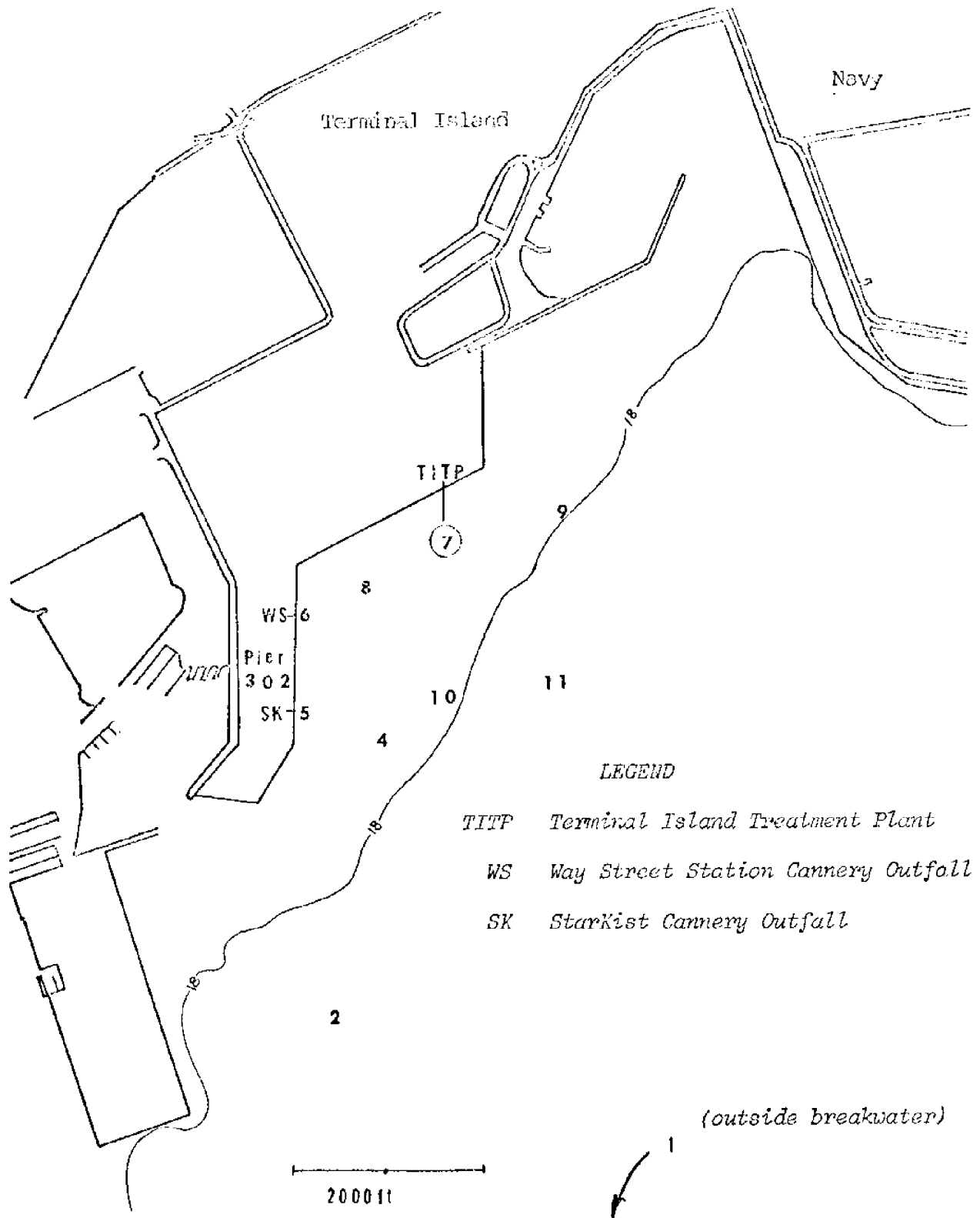

Figure F1. Cannery/Treatment Plant (CTP), Special Stations, 1976

Table F8. Physical Characteristics of Surface Water Samples
August 23, 1976

Station *	Temperature	Salinity	DO
1 (A-1)	17.1	32.3	7.5
2	19.0	33.0	7.1
3	18.5	31.9	6.8
4	18.5	32.0	7.0
5 SK	19.5	29.9	6.2
6 WS	20.0	30.0	3.2
7	18.8	27.8	6.8
8	19.7	30.9	5.1
9	19.0	31.9	8.9
10	19.0	30.5	6.2
11	19.5	30.0	7.6

* See Figure F1 for station location.

values.

Assimilation ratios were not directly measured but were calculated by dividing the values determined for productivity by the values determined for chlorophyll *a* concentrations.

Culturing experiments were initiated with unialgal cultures of *Peridinium trochoideum*, a dinoflagellate, and *Chaetocerus affinis*, a diatom, both of which are commonly found in the harbor.

Replicate 500 ml flasks for each station and each species of phytoplankter were autoclaved and 150 ml of Millipore filtered seawater added. Stock culture density was determined and one ml of culture stock was injected into replicate flasks and counted daily. *P. trochoideum* was counted with a Coulter Counter Model B and daily samples of *C. affinis* were fixed in Lugol's solution and are in preparation. The cultures were illuminated by fluorescent tubes while maintained in an environmental chamber at $18^{\circ} \text{C} \pm 0.5^{\circ} \text{C}$. Toxicity of the seawater sample was based on the duration of the lag phase and cell density. Eutrophication was based on growth response time and cell density at steady state conditions.

RESULTS

The primary productivity measured indicates the ability of the autotrophic organisms to produce organic matter. Uptake rates of ^{14}C at the control station located outside the harbor (A1) were similar to CTP stations 2, 10 and 11 (Table F9). The lowest rates of ^{14}C incorporation (.01 to .83 mgC/hr/m³) occurred at both the cannery discharges (stations 5 and 6) and adjacent to the

Harbors Environmental Projects University of Southern California

Way Street outfall (station 8). The TITP outfall (station 7) yielded higher rates of ^{14}C incorporation than the cannery outfalls (6.67 mgC/hr/m^3). The maximum rate of uptake occurred at station 4 (11.81 mgC/hr m^3).

The chlorophyll *a* measure indicates the standing crop or the organic production potential of the phytoplankton community. Chlorophyll *a* values indicated that the lowest standing crop of phytoplankton occurred at the Way Street outfall, station 6 (Table F9). The outside Harbor station A1 and stations 9 and 11 represented intermediate standing crop levels (2.41 to 3.63 mg/m^3). Stations 2, 3, 4, 5, 7, 8 and 11 (5.37 to 15.33 mg/m^3) were higher than the station A1 outside the Harbor.

The assimilation ratio which is a measure of the efficiency of the standing crop in the production of organic matter can indicate the degree of stress to the phytoplankton community with respect to limiting or inhibiting conditions. The control station (A1) outside the Harbor yielded the highest assimilation ratio of 2.91 (Table F9). An intermediate range of efficiency was represented by stations 2, 3, 4 and 10 which ranged from 1.07 to 1.82. The lowest assimilation ratio or poorest efficiency occurred nearest the outfalls (stations 5, 6, 7, 8, 9) with assimilation ratios ranging from 0.06 to 0.99.

Concentrations of nitrite, nitrate, phosphorus and ammonia were higher nearest the outfalls at stations 5, 6, 7 and 8 (Table F10). Nitrite concentrations ranged from 0.90 to 0.22

microgram atoms/liter. Those stations further from the discharge ranged from .09 to .02 $\mu\text{g a/liter}$. Nitrate concentrations near the discharge sites ranged from 2.78 to 7.93 $\mu\text{g a/liter}$, with concentrations of .91 to 2.61 $\mu\text{g a/liter}$ at those stations further from the outfalls.

The concentration of phosphate (PO_4) at those stations nearest the outfalls ranged from 10.74 to 34.92 $\mu\text{g a/liter}$. Lower concentrations occurred further from the outfall and ranged from 0.63 to 4.50 $\mu\text{g a/liter}$.

Concentrations of ammonia (NH_3) were also higher near the discharges (32.46 to 59.56 $\mu\text{g a/liter}$). Those stations further from the outfalls were for the most part an order of magnitude less in range (0.56 to 11.16 $\mu\text{g a/liter}$).

The growth response of *Peridinium trochoideum* in filtered seawater samples collected from the receiving waters nearest the outfalls showed either a negative or very slight growth response (Table 11). Growth in samples from those stations further from the outfalls (stations 2, 3, 4, 9, 10, 11) showed the shortest lag phase, about two days, and reached a greater cell density at the steady state growth phase than in the sample from the control station, number 1.

DISCUSSION

The reduced lag phase and high cell densities of *P. trochoideum* supported at the steady state phase in samples from the outer stations from the discharges suggests a "bioenhancement" or enrichment property of these waters. The samples from the

innermost stations produced a poor or negative response. High nutrient levels may have produced an inhibitory or toxic response from the phytoplankton.

The rapid growth response of *P. trochoideum* at moderate levels of ^{14}C incorporation suggests that a greater potential enhancement in waters collected from the outer stations is possible than is presently occurring within the field phytoplankton community. The poor response of ^{14}C assimilation may be caused by a variety of factors, some of which would include turbidity, chemical and biological inhibitors and trophic relationships of populations within the receiving waters.

The high concentration of inorganic nutrients represents a potential reservoir for growth response of the phytoplankton community. The usual range of these nutrients in sea water is 0.01 to 50 $\mu\text{g}/\text{liter}$ for nitrate, 0.01 to 5 $\mu\text{g}/\text{liter}$ for nitrite, and 0.1 to 5 $\mu\text{g}/\text{liter}$ for ammonia (Parsons, et al., 1973). Most algae do not have the ability to fix molecular nitrogen and must utilize inorganic salts. With respect to nitrite, nitrate, and ammonia, ammonia is utilized in preference to nitrate (Eppley, et al., 1969). Ammonia is used directly for amino acid synthesis through transamination, but nitrite and nitrate must be reduced before entering into cell synthesis.

Table F9. Primary productivity, standing crop and assimilation ratio in phytoplankton of surface water samples, August 23, 1976

Station	Primary Productivity mg C/hr/m ³	Total Chlorophyll <i>a</i> mg/m 2x(2.45)	Assimilation Ratio
1	9.76	3.34	2.91
2	9.16	7.08	1.29
3	6.30	5.37	1.17
4	11.81	6.47	1.83
5	0.83	12.72	0.06
6	0.01	---	---
7	6.67	15.33	0.43
8	0.51	5.76	0.09
9	2.40	2.41	0.99
10	8.19	7.63	1.07
11	8.95	3.63	2.46

Table F10. Nutrient Concentrations ($\mu\text{g}/\text{liter}$) of Surface Water Samples August 23, 1976

Station	NO ₂	NO ₃	PO ₄	NH ₃
1	.09	2.61	0.91	0.92
2	.04	1.23	1.56	5.45
3	.02	0.91	1.89	4.48
4	.05	1.71	2.74	2.65
5 SK	.09	2.78	10.74	46.21
6 WS	.09	3.73	24.72	54.06
7 TITP	.13	4.09	22.38	59.56
8	.22	7.93	34.92	32.46
9	.05	1.59	0.63	0.56
10	.06	1.74	4.37	11.16
11	.04	1.21	4.50	9.73

Table F11. Growth of *Peridinium trachoidium* in Filtered Sea Water Collected from the Receiving Waters (cells/ml)

Stations	Days										
	0	1	2	3	4	5	6	7	8	9	10
1	198	200	174	219	400	707	1009	595	1274	2568	3491
2	261	297	260	562	1149	1879	3024	1923	2823	3060	3584
3	262	360	382	691	1429	2261	4142	3530	3506	3945	4866
4	276	287	321	612	1410	2275	3536	3299	3816	5314	5079
5	369	547	576	686	574	629	790	512	563	440	533
6	356	495	446	392	454	537	837	457	647	657	1108
7	352	456	430	506	519	467	472	198	137	177	147
8	335	496	377	627	1146	1269	1538	744	804	517	722
9	390	362	446	777	1571	3095	4486	2806	3257	3206	3017
10	261	199	212	585	1118	1829	2860	1815	2248	2811	3736
11	526	435	403	977	2080	3425	5574	4035	4930	6957	8234

LITERATURE CITED

- Akesson, B. 1970. *Ophryotrocha labronica* as a test animal for the study of marine pollution. *Helgolander wiss. Meeresunters.* 20:293-303.
- Allen, L.A., et al. 1946. Toxicity to fish of chlorinated sewage effluents. *Surveyor (G.B.)*, 105, 298.
- Brook, A., and A. Baker. 1972. Chlorination at power plants: Impact on phytoplankton productivity. *Science. N.Y.* 176:1414-1415.
- Brungs, W.A. 1973. Effects of residual chlorine on aquatic life. *J. Water Poll. Control Board.* 45(10):2180-2193.
- Doudoroff, P., and M.C. Katz. 1950. Critical review of literature on the toxicity of industrial wastes and their components to fish. *Sew. and Ind. Wastes*, 22:1432.
- Emerson, R. 1974. Preliminary investigations of the effects of resuspended sediment on two species of benthic polychaetes from Los Angeles Harbor. *In Marine Studies of San Pedro Bay, California. Part 3.* Allan Hancock Foundation and Sea Grant Program, Univ. So. Calif., 97-110.
- Eppley, R.W., J.L. Coatsworth, and L. Solorzano. 1969. Studies of nitrate reductase in marine phytoplankton. *Limnol. Oceanogr.* 14:194-205.
- Hirayama, K., and R. Hirano. 1970. Influences of high temperature and residual chlorine on marine phytoplankton. *Mar. Biol.* 7:205-213.
- Kopperdahl, F.R. 1976. Guidelines for performing static acute toxic fish bioassays in municipal and industrial waste waters. *Calif. Water Res. Control Board.* 66 p.
- McKee, J.E., and H.W. Wolf. 1963. Water quality criteria. 2nd ed. Publ. 3A. Calif. State Water Quality Control Board.
- Merkens, J.C. 1958. Studies on the toxicity of chlorine and chloramines to the rainbow trout. *Water and Waste Treatment Jour.* 7:150.
- Neilsen, E.S. 1952. The use of radioactive carbon (^{14}C) for measuring organic production in the sea. *Rapp. Cons. Explor. Mer.* 144:92-95.
- Parsons, T.R., and M. Takahashi. 1975. Biological oceanographic processes. Pergamon Press. p. 75.

Reish, D.J., and J.L. Barnard. 1960. Field toxicity tests in marine waters utilizing the polychaetous annelid *Capitella capitata* (Fabricus). Pacific Naturalist. 1(21-22):2-8.

Strickland, J.D.H., and T. R. Parsons. 1968. A practical handbook of seawater analysis. Fish. Res. Bd. Canada Bull. 167, 311 p.

Part G.

PHYTOPLANKTON STUDIES:

PROGRESS REPORT

by

Gregory Morey-Gaines
Harbor Environmental Projects
University of Southern California
Los Angeles, California 90007

This study is designed in three parts: 1) a field study of zooplankton and phytoplankton species abundances in the Los Angeles-Long Beach Harbor; 2) gut content analysis of the zooplankton; and 3) laboratory grazing studies of the feeding patterns of the zooplankton. Data from the first part is the most current and complete, so only the field study will be reported here.

Sampling is being carried out weekly at four stations in the Los Angeles-Long Beach Harbor area (Figure G1). Triplicate plankton samples are taken at each station at the surface, at three meters, and at six meters depth. The phytoplankton in a one milliliter water sample are fixed with Lugol's solution, allowed to settle, then counted and identified using a Zeiss inverted microscope. The zooplankton from a four liter water sample are retained by a 102 micron mesh net, fixed in buffered formalin, then counted and identified using a Wild dissecting microscope. These water samples are collected from a 16½ foot Boston Whaler using a hand pump and hose system.

Plankton Station 1 (PL1) is outside the breakwater, and is presumed to represent more nearly the conditions of the open coast adjacent to the harbor. Comparing this station to the other three, all of which are within the harbor, will provide evidence of the effect harbor conditions have upon the plankton. Table G1, and to a lesser extent, Figure G2, shows a difference between phytoplankton counts at Station PL1 and the stations inside the harbor, most clearly represented by the mean of stations PL2, 3, and 4. However, the data available are too few to in-

terpret this as a statistically significant difference. In addition, these data represent only a short period during the year, and this difference may not extend to other seasons. However, it has been observed during the fall that dinoflagellate blooms often begin and are most intense in the harbor, even though coastal blooms may extend throughout San Pedro and Santa Monica Bay. Table G2 and Figure G3 present the same kind of information for zooplankton, for which the data are more complete. Again, the concentration of organisms is higher in the harbor than outside. Once again, though, this mean difference is not statistically significant, due to the large fluctuations in abundance from spring to summer to fall.

Station PL3 is located near the cannery and sewage outfalls, and is presumed to represent more nearly the effects of these discharges than the other two harbor stations, PL2 and PL4. Comparison of Station 3 phytoplankton with the phytoplankton of stations 2 and 4 in Table G1 and Figure G2 shows marked differences. Station 3 has a higher phytoplankton concentration. However, these differences are not statistically significant, due to the sparseness of the data and to seasonal variation. The zooplankton (Table G2 and Figure G3) appear to be somewhat reduced at station 3 from the mean of the other two stations, 2 and 4. This is doubtless due to the extremely high counts at station 4, and is not statistically significant.

To summarize, preliminary data suggest that the plankton of the harbor is more abundant than that of the open coast. It is assumed that cannery and sewage discharges play a role in this increase. The zooplankton populations near the outfalls at sta-

tion 3 are not significantly greater than the other areas sampled in the harbor. The phytoplankton populations at this station are greater than at other stations, but the data available are too few to be conclusive. From these data, it would appear that the absence of these discharges would reduce the populations of plankton in the harbor to levels approaching those found outside the harbor.

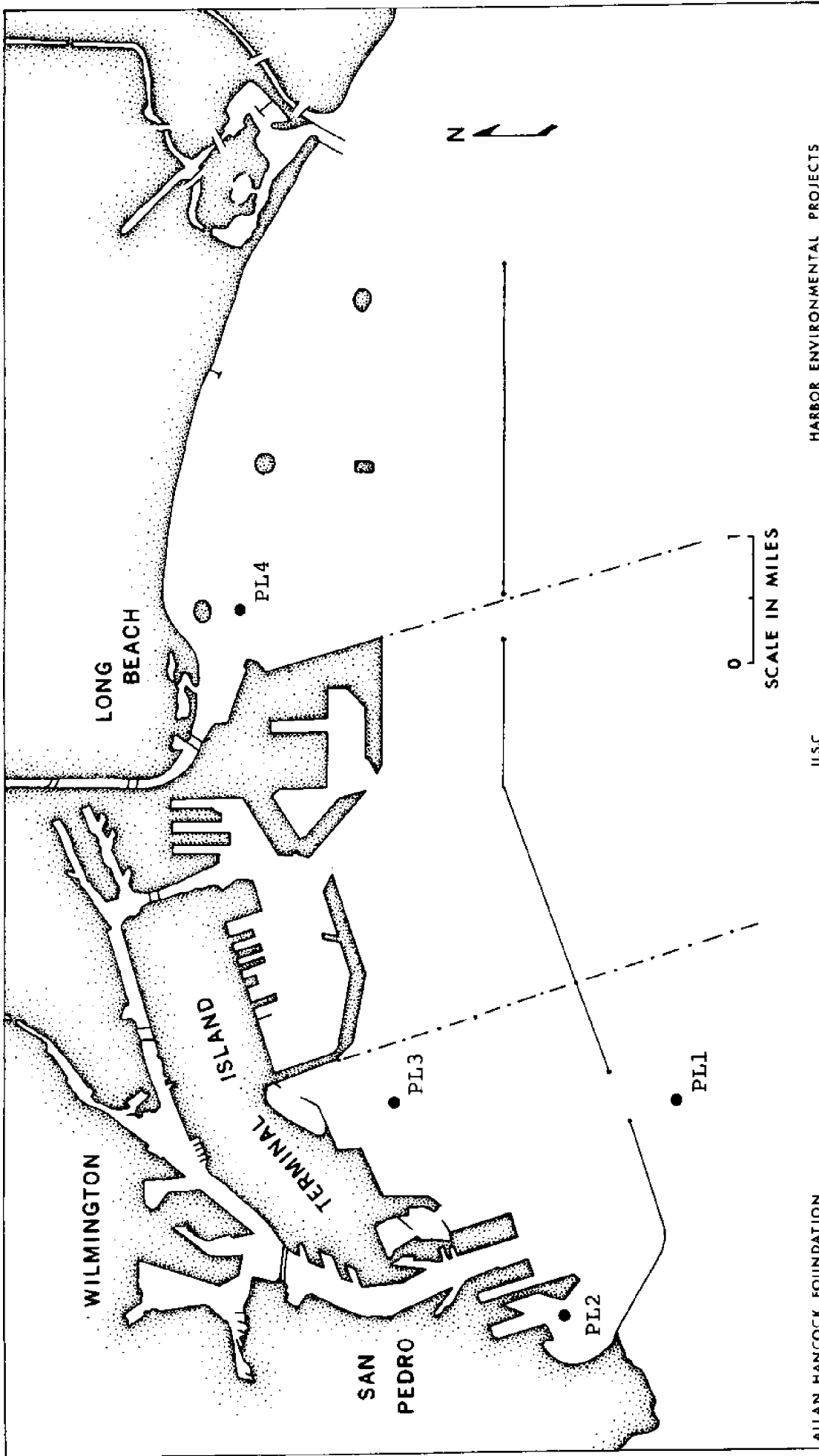

Figure G1. Plankton Sampling Stations.

Table G1. Concentration of Phytoplankton (cells in one milliliter).

Date	Station 1	Station 2	Station 3	Station 4
April 12	-	-	6,013	2,936
May 10	5,389	2,526	9,680	6,324
May 17	1,040	3,109	968	407
May 24	56	685	3,480	806
May 31	-	254	-	1,115
June 7	23	645	-	880
Means*	2,162	2,107	4,709.5	2,512

* Dates with missing data omitted from the calculations.

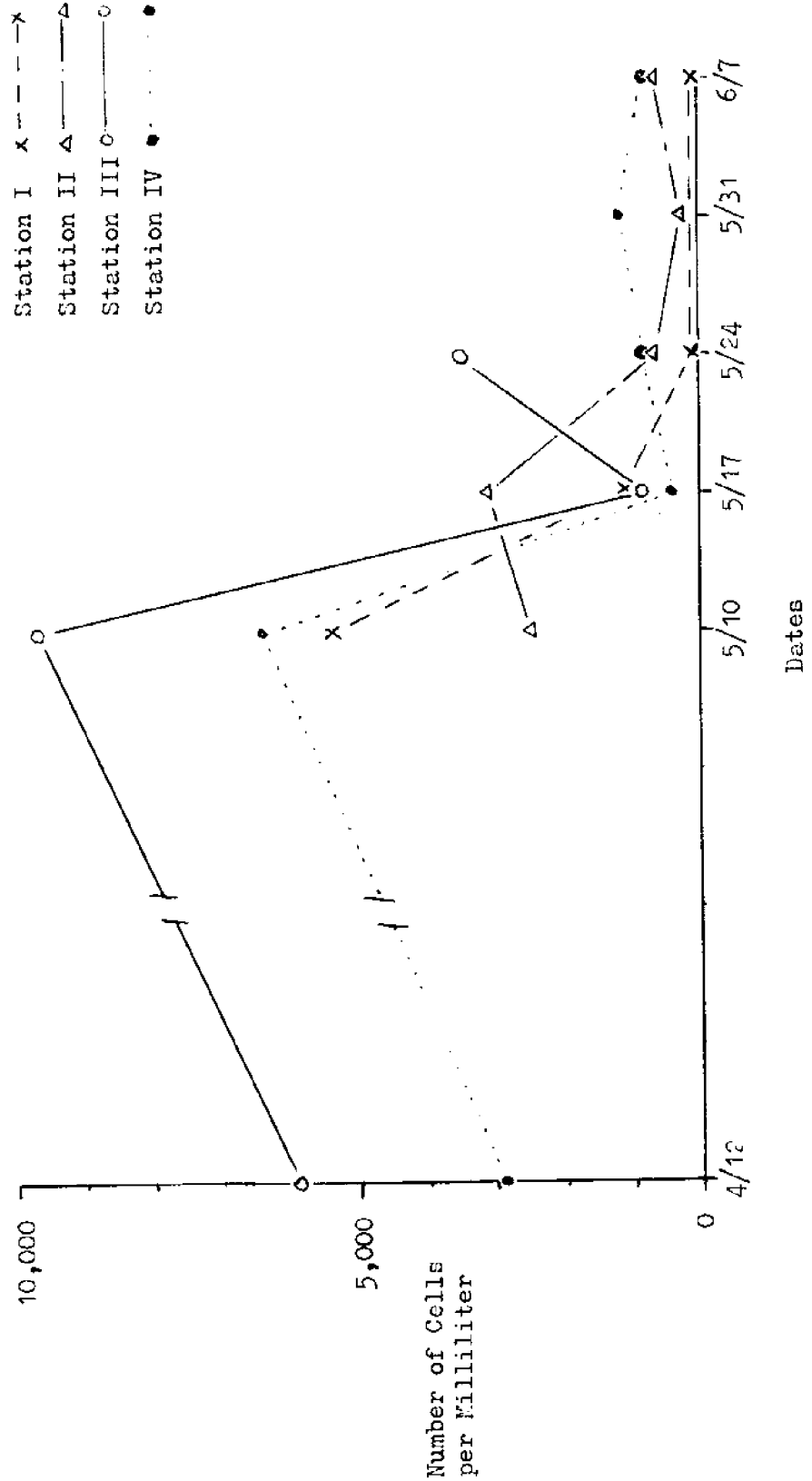

Figure G2: Concentration of Phytoplankton (Cells in One Milliliter).

Table G2. Concentration of Zooplankton (organisms in four liters), excluding copepod nauplii.

Date	Station 1	Station 2	Station 3	Station 4
April 26	55.75	43.5	48.5	67.0
May 3	-	222.0	67.7	21.0
May 10	55.0	48.0	41.0	42.3
May 17	10.3	13.7	22.3	47.0
May 24	6.7	37.3	32.7	116.3
May 31	54.3	79.7	129.0	204.3
June 7	18.0	42.3	58.0	39.3
June 14	36.3	26.3	33.3	77.3
June 21	-	43.0	49.3	-
June 28	10.7	10.7	12.0	11.3
July 5	25.0	7.3	16.7	13.3
July 12	73.7	-	20.0	20.0
July 19	24.0	5.7	12.3	-
July 26	8.0	18.3	23.7	19.7
August 2	21.3	8.0	10.0	27.3
August 9	20.3	22.7	43.0	74.3
August 16	71.3	79.0	87.0	-
August 23	65.3	42.3	79.0	137.3
August 30	56.0	79.3	71.3	250.0
Sept. 6	47.3	58.7	30.3	107.0
Means*	32.7	35.9	43.4	82.25

* Dates with missing data omitted from the calculations.

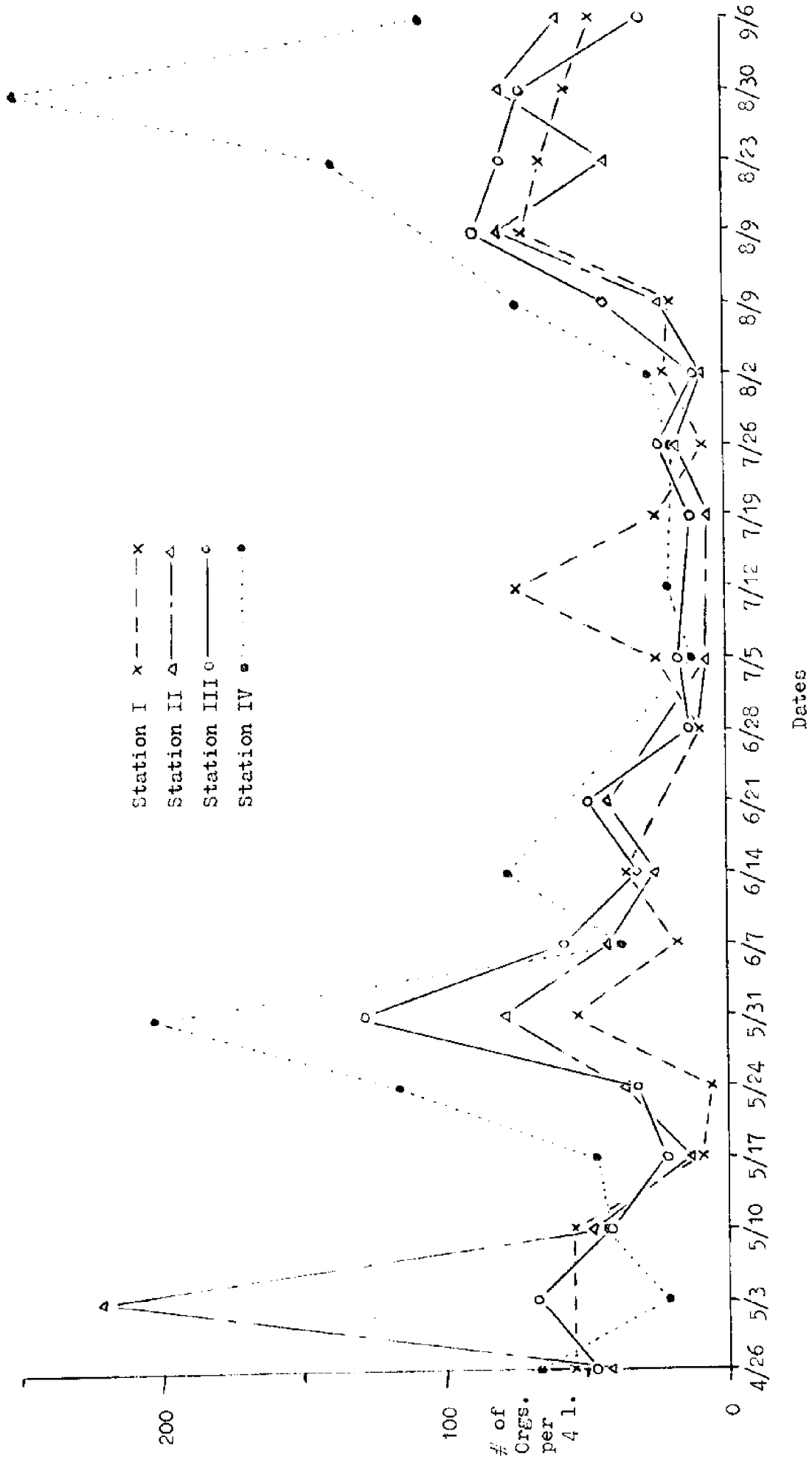

Figure G3: Concentration of Zooplankton (Organisms in Four Liters), excluding copepod nauplii.

Errata

Marine Studies of San Pedro Bay, California, Part 12

p. 114, line 30 read: Riley, G.A. 1960.

