

**SHELFED**

**CRAB PRODUCTION**  
**OPTIONS AND OPPORTUNITIES**

**Jerald Horst**



SOFT-SHELLED CRAB PRODUCTION  
*Options and Opportunities*

By

Jerald Horst  
Louisiana Cooperative Extension Service

Louisiana Sea Grant College Program  
December 1992





**LOUISIANA  
SEA GRANT**  
COLLEGE PROGRAM



Louisiana State University  
**Agricultural Center**  
Louisiana Cooperative Extension Service

Additional copies of this publication are available from Louisiana Sea Grant College Program, Louisiana State University, Baton Rouge, LA 70803-7507, (504) 388-6448.

This publication is a result of extension work sponsored by the Louisiana Sea Grant College Program. This program is maintained by the NOAA National Sea Grant College Program Office, Department of Commerce, and by the State of Louisiana.



## INTRODUCTION

The shedding of blue crabs to produce the more commercially valuable soft-shelled form has been done for at least one hundred years in the United States. Soft crab prices have consistently been much higher than the prices for hard-shelled crabs. In spite of the best efforts of many researchers, no one has yet developed a profitable system for the culture of crabs from eggs to marketable animals. The supply of soft crabs depends upon the ability of commercial fishermen to catch and recognize crabs that are nearing the molt of their shells.

The publication is designed to assist people who are considering shedding blue crabs. Although the sections on open systems and float cars are relatively complete, the reader will have to consult a much more detailed reference on closed systems. The reader may also get hands-on assistance from marine extension personnel assigned to local parish offices of the Louisiana Cooperative Extension Service and the LSU Agricultural Center, Baton Rouge.

## BIOLOGY

The blue crab (*Callinectes sapidus*) is commonly found on the Gulf and Atlantic coasts of the United States. Blue crabs possess an outer hard shell called an exoskeleton. Unlike skin, the hard shell cannot stretch with growth, so the crab must shed its shell, or molt, as many as 25 times in its lifetime in order to grow. Before molting, the crab forms a new soft shell under the old one. After casting off the old shell, the crab swells with water to a larger size and the new soft shell becomes hard within 12 hours. The crab then begins to feed and add weight inside its new shell.

Small crabs may molt every few days. As they become larger, the period between molts becomes longer. Female crabs do not molt (with rare exceptions) after reaching sexual maturity. Soft crab shedding systems are designed to put near-molt crabs in a controlled environment, so they can efficiently be harvested during the few hours that the shell is soft.

## SUPPLY

The first requirement is access to a reliable supply of crabs that are near shedding stage. These are called premolts or "busters". Surprisingly, this is often the most overlooked consideration. Buster crabs must be obtained from the commercial harvest of wild blue crabs, either by catching them or buying them from crab fishermen. For the blue crab fisherman, the decision is easy. He must simply decide if it is worth the effort to grade crabs as they are caught and to separate and carefully handle the busters.

A person planning to buy busters must consider several factors. First, are there enough crabbers in the immediate area who would be willing



to sell busters at a reasonable price? In many areas, especially in south-eastern and south-central Louisiana, blue crab shedding technology is well known, and crab fishermen who are inclined to grade their crabs may already be shedding their own catches.

If the shedding system operator has to pay a high price for busters as incentive for fishermen to grade their crabs, it may not be profitable. Buster crabs are delicate animals and handling them carelessly before they are put in the shedding system may kill more than 50 percent. If buster crabs cost 75 cents each and the market price for soft crabs is \$1.50 (prices for example purposes only) the shedder will obviously lose money with a 50 percent mortality rate. Crabbers who handle their busters with the utmost care can keep mortality rates under 10 percent.

### **TIME REQUIREMENTS**

The time available to devote to shedding operations may be a constraint. The production of soft crabs is labor intensive. Buster crabs placed in the shedding system must be graded, crabs within the system must be graded, and soft crabs must be removed and packaged. Buster crabs are graded according to how far they are from shedding. White-sign crabs are 7 to 14 days from shedding, pink-sign crabs are 3 to 6 days removed, red-sign crabs are 1 to 3 days removed, and cracked busters are within 24 hours of shedding. White-sign crabs should be graded every three days and crabs that have developed pink and red signs should be maintained separately. White-sign crabs are still feeding vigorously and cannibalize red and cracked crabs if not separated. (White-sign crabs must be fed in order to molt successfully, so they cannot be used in a closed or recirculating system unless a sand filter is used.) Red-sign crabs must be checked once a day for the appearance of cracks. Cracked busters must be checked every three to four hours.

Once a crab has shed its shell and been allowed to expand to its full size, it must be removed from the water immediately or its shell will harden. Soft crabs may be temporarily stored in a refrigerator and wrapped or packaged once a day. Some buyers also require that soft crabs be cleaned before packaging.

### **CHOICE OF SHEDDING SYSTEMS**

Soft crab shedding systems fall into one of four categories:

- (1) Float cars
- (2) Onboard flow-through or open systems
- (3) Land-based flow-through or open systems
- (4) Closed or recirculating systems



Float cars are the simplest and closed or recirculating systems are the most complex of the systems. Each has its advantages and drawbacks. In general, the simpler the system, considering location and water quality, the fewer technical problems can be expected.

### **Float Cars**

Float cars come in a variety of shapes and sizes. Some are buoyant because they are made of wood (Figure 1) or have built-in flotation (Figure 2). The shedder can work these cars from a small boat, by wading in the water or by hauling them onto a low wharf. Cars may also be raised and lowered with a windlass system. The shedder can step into the car from the wharf to grade the crabs (Figure 3). Others are designed to be lifted onto a floating or stationary wharf (Figure 4).

Wood float cars should be made of cypress if possible, and any hardware cloth used should be vinyl-covered. Holes drilled for circulation or gaps in slats should be no larger than  $\frac{1}{4}$  inch in diameter to prevent fish from biting off the crab's legs.

The advantages of float cars are:

- (1) They are inexpensive.
- (2) They have few mechanical parts to maintain.
- (3) They are not affected by electrical or pump failures.
- (4) White-sign crabs may be fed in them.

The disadvantages of float cars are:

- (1) Poor water quality (caused by rapid salinity changes, poor oxygen levels, silt suspended in the water, or high hydrogen sulfide levels) can prevent shedding.
- (2) Waterfront property is needed for the operation.
- (3) The shedder has to tend the floats while exposed to the weather.

### **Onboard Flow-Through or Open Systems**

These systems are simply shallow boxes (no more than 16 inches deep) which are placed on the deck of a shrimp trawler for the shedding of buster crabs that are caught incidentally in trawls (Figure 5). Sea water is recirculated through the system by a small pump or the system is periodically flushed with the deck hose. Almost any size or shape of box will do, but it should be equipped with a drain plug.

The advantages of onboard flow-through or open systems are:

- (1) They are inexpensive and simple to operate.
- (2) They are easily removed when not needed.



The disadvantages include:

- (1) One must own a shrimp trawler or other large vessel.
- (2) The system takes up a lot of deck space.

### **Land-Based Flow-Through or Open Systems**

These are fiberglass or fiberglass-coated wooden boxes, built much like tables, to a height convenient for the shedder (Figure 6). If space is at a premium, shedding boxes can be stacked like bunk beds. Water is drawn from a nearby bayou or lake and pumped through the system, draining back into the bayou after one pass. If no suitable surface water is nearby, water from a saltwater well may also be used, but the salinity must be right.

No part of this system that is in contact with the water should be constructed of metal. Most metals are either poisonous to crabs or corrode easily. The pump may or may not be submersible. A 1 $\frac{1}{2}$  horsepower swimming pool pump will usually handle three 4 x 8-foot shedding boxes with a capacity of 800 to 900 crabs. The shedding boxes should be located under a roof to keep rain and debris from entering the tanks, to provide shade, and for the comfort of the shedder.

Particular attention should be paid to the construction of the standpipe (Figure 7) since it will determine the level of water in the tank. It should be removable so that the shedder can control the water level by changing pipes and allow the tank to drain. A hole, no larger than  $\frac{1}{4}$  inch, should also be drilled in the standpipe  $\frac{1}{2}$  inch above the tank bottom to allow the tank to slowly drain in the event of a power failure. The small amount of water left will allow the crabs to keep their gills wet and breathe air. Without the small hole, the crabs would quickly use up oxygen in the water and die in the 4 to 6 inches of water in the tank during a power failure. When power is restored, the tanks will quickly refill. The tanks can be made self-cleaning by inserting over the standpipe a longer, larger pvc pipe with the notches cut from the bottom. This will force the standpipe to pick the water up from the bottom of the tank, effectively flushing dirt and other debris from the tank.

The advantages of a land-based flow-through or open system are:

- (1) The shedder can aerate the water supply.
- (2) The system does not have to be located immediately on the water.
- (3) The shedder is protected from the weather, can use electric lights, and doesn't have to bend over the tanks.
- (4) No crab losses are suffered during short power failures.
- (5) The system is immediately operable at full scale since there is no filter to be conditioned.
- (6) White-sign crabs may be fed in the system.



The disadvantages are:

- (1) The system must be fairly near water (unless a well is used).
- (2) Silt or hydrogen sulfide in the water source may kill the crabs.

### **Closed or Recirculating Systems**

These systems are similar to land-based flow-through systems except that the same water is recirculated. Water is added only to make up for evaporation. Water leaving the shedding tanks flows by gravity into a filter system. The filter is made up of clam shells, limestone, sand, or plastic beads on which bacteria grow. These bacteria consume the ammonia that crabs give off as a waste product. Without the bacteria, the ammonia would quickly build up to toxic levels and kill the crabs. From the filter, the water is pumped back to the shedding tanks. Three 4 x 8-foot shedding boxes with a working filter 1 foot deep, 4 feet wide, and 8 feet long will support 900 crabs at any one time, usually enough for a single crabber's production.

The advantages of a closed or recirculating system are:

- (1) Poor environmental water quality doesn't affect the system.
- (2) The system can be located anywhere.
- (3) The shedder has good working conditions.

The disadvantages include:

- (1) This system is more complex than the others.
- (2) If the system is not carefully designed, a power failure can result in loss of either crabs or water.
- (3) Time is necessary to grow the bacteria before the system can be used at full capacity.
- (4) White-sign crabs cannot be fed unless a sand or bead filter is used.

The details of constructing and operating such a system are too lengthy to discuss here but are thoroughly covered in the publication, *Design of Recirculating Blue Crab Shedding Systems*, by Ronald F. Malone and Daniel G. Burden. The publication may be ordered from the Louisiana Sea Grant Communications Office, LSU, Baton Rouge, Louisiana 70803. The cost is \$10.

### **HARVESTING BUSTER CRABS**

Buster crabs are usually available each year from the middle of March through October, with some variation caused by weather conditions. Peak production usually occurs in April or May with another smaller peak in September. The vast majority of premolt or buster crabs produced in Louisiana are caught with standard blue crab pots (Figure 8) and are separated from the others during the course of fishing.





Buster crabs are also harvested by other methods. Some are caught with shrimp trawls. In parts of Lake Pontchartrain, fishermen dip buster crabs with dip nets from marine grass beds. Probably the most unusual method of harvesting buster crabs is with bushlines (Figure 9). The bushline is basically a heavy trot line with bundles of wax myrtle (locally called *seria*) instead of hooks. Crabs that are near molting enter the bushes apparently for protection. The crabber gently raises each bush and uses a large dipnet to catch any crabs that fall from the bush when it is shaken (Figure 10). Almost all the crabs produced by this method are red-sign or cracked crabs. This method of producing buster crabs is used extensively in central and upper Barataria Bay but has not been successfully adapted for use elsewhere.

Peeler pounds, crab scrapes, and jimmy pots are illegal in Louisiana and elsewhere have been only marginally successful for producing buster crabs.

### **HANDLING PREMOLT CRABS**

The most important step in the shedding process may be the proper handling of buster crabs after they have been caught and before they are put in a shedding system. This is especially true if the shedder has to buy the busters.

The most successful producers immediately put busters in a separate crate filled with evergreen branches (usually wax myrtle, although other plants can be used). The branches shade, cool, and cushion the crabs and prevent their points from poking holes in other crabs. They also calm them and prevent them from pinching each other. A crab with even a small hole in its shell usually will not shed successfully.

When the buster crate is as full as desired, it should be covered (leaving the bushes in), with wet burlap sacking material and placed out of the wind and the sun. The burlap covering must be kept moist. At the dock, the buster crate should be handled and transported gently. The crate should never be left in a vehicle parked in the sun. Also remember that the sooner the crabs are placed in the system after being caught, the better. Efficient, careful handling makes the difference between a 50 percent shedding rate and a 90 percent rate.

### **LEGAL CONSIDERATIONS**

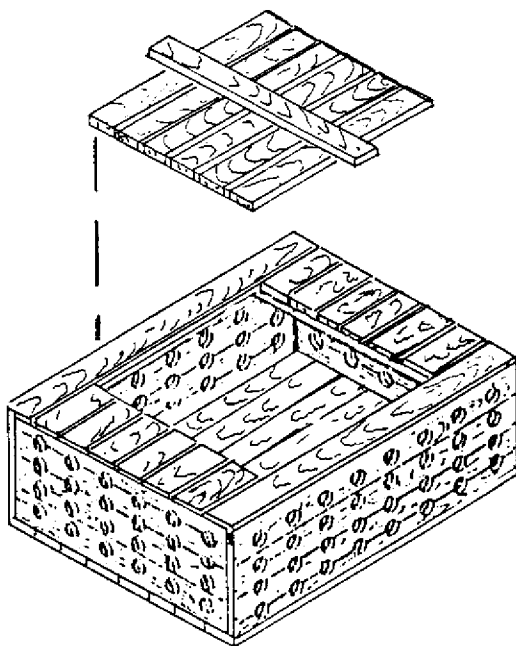
It is important to know the licensing requirements before catching, buying, or selling busters or soft crabs. The minimum size requirements may be different from those for hard crabs. The licensing section of the Louisiana Department of Wildlife and Fisheries has licensing information. The Enforcement Division of the same department or the local marine advisory agent in the Cooperative Extension Office should have the other legal requirements, which may occasionally change.



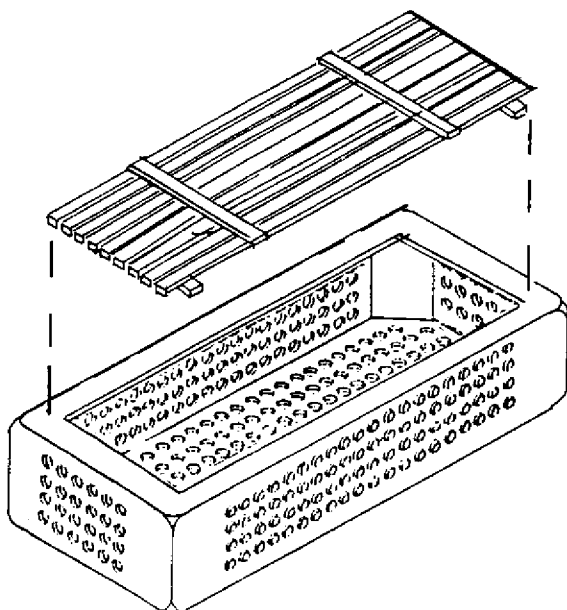
# FIGURES

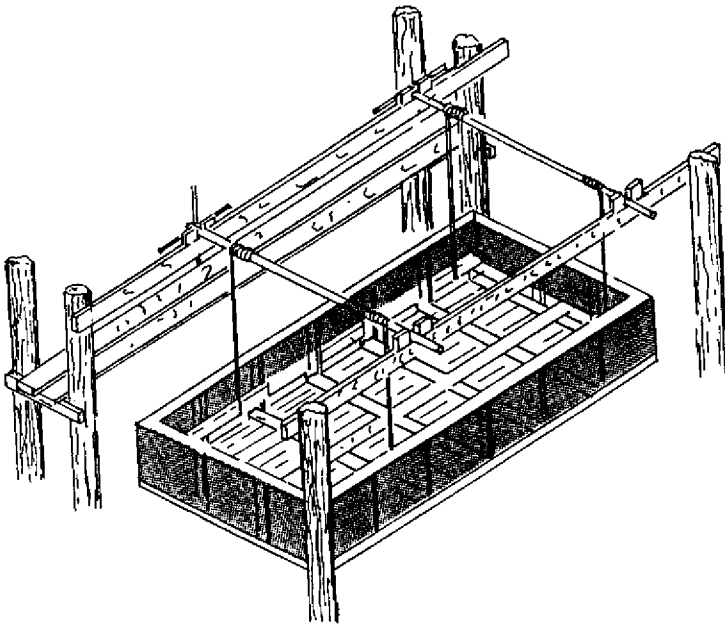


**Figure 1.** The shape of this float car allows it to face into the waves when anchored or tied off.

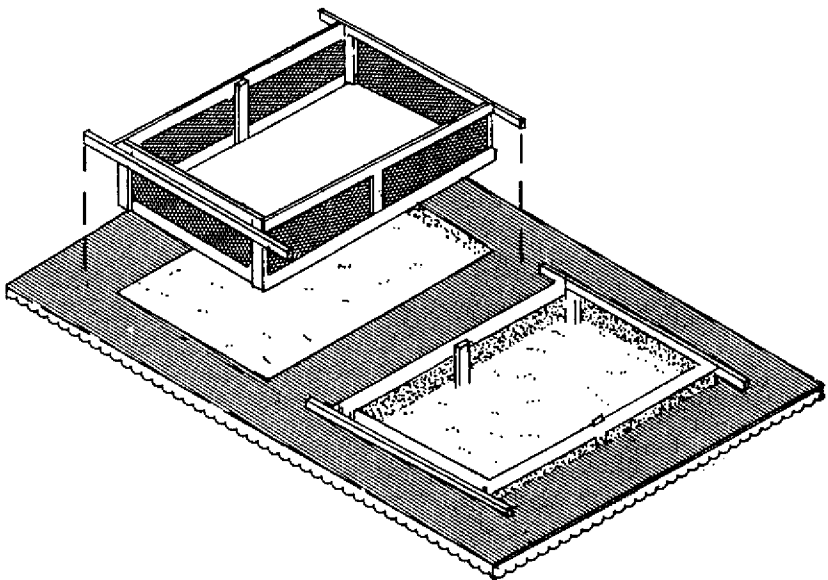


**Figure 2.** A fiberglass float car with air pockets built into the corners for flotation.



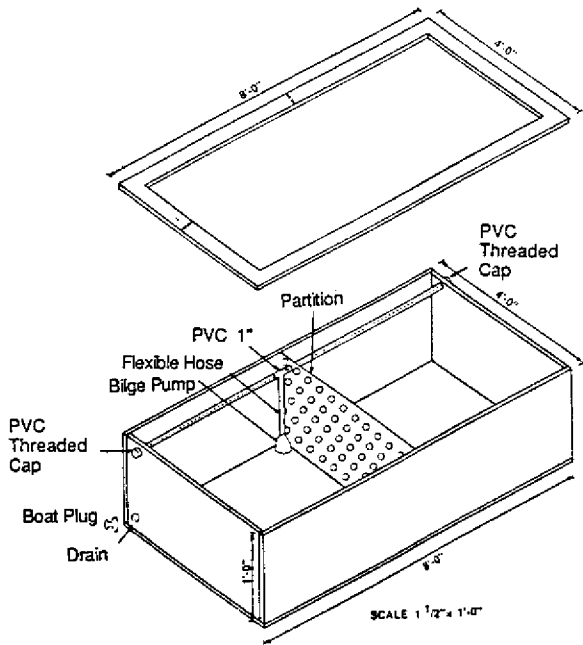


**Figure 3.** The wooden framing on this float car provides flotation. Note the runner boards in the bottom of the car on which the shedder stands.

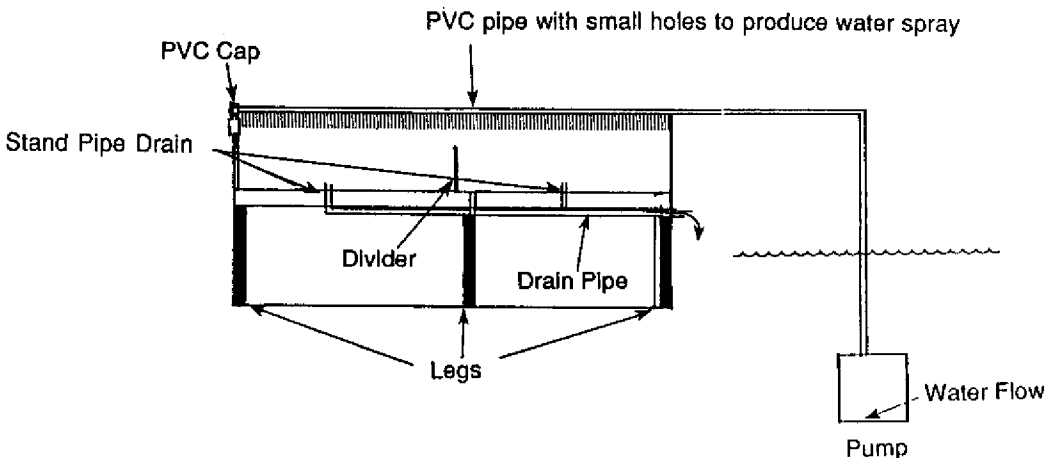


**Figure 4.** These float cars are constructed of lightweight materials for ease of handling.

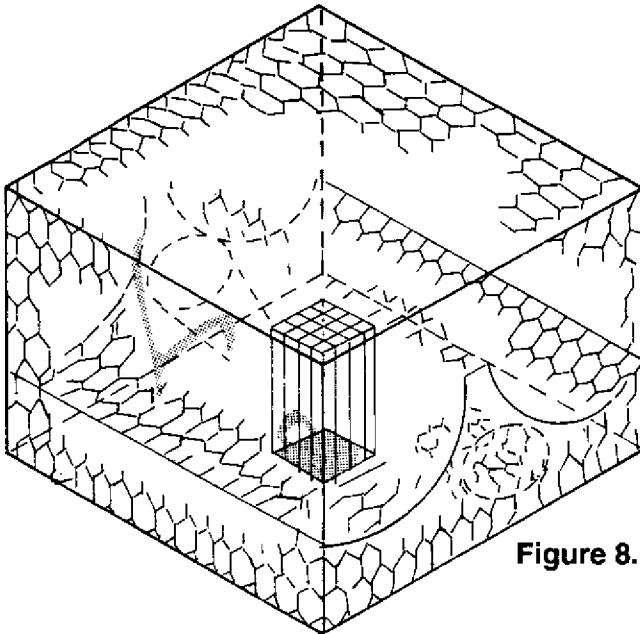
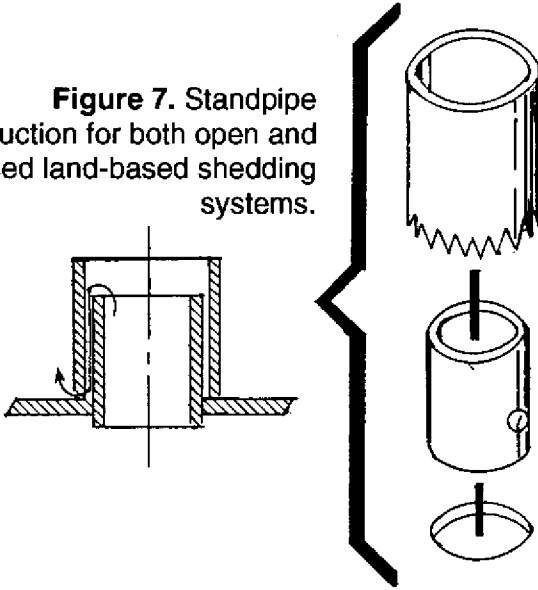
**Figure 5.** These boxes may be constructed of fiberglass or fiberglass-covered wood. Note the partition and the lip on the top edge of the box to prevent the water and crabs from sloshing out.



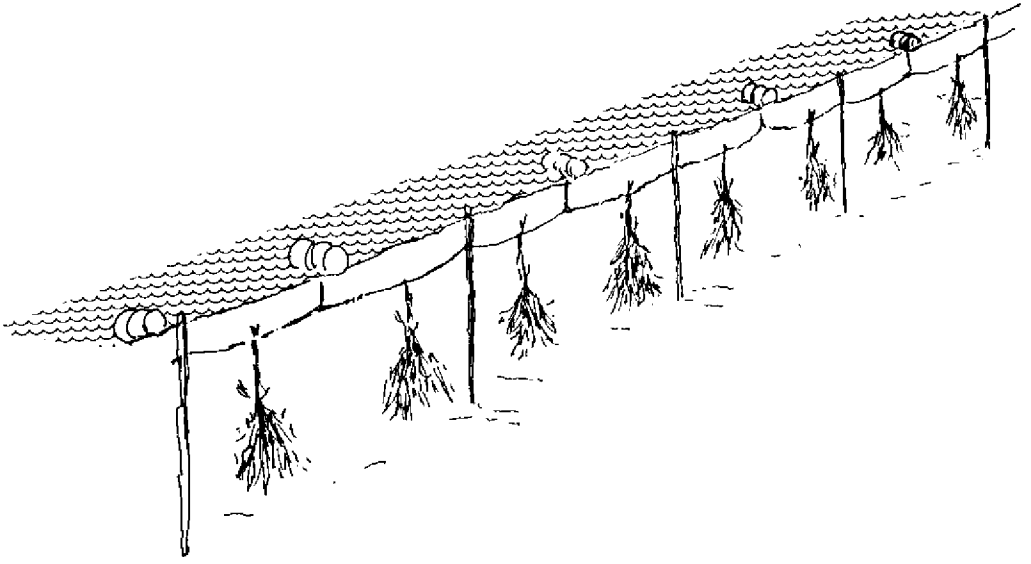
**Figure 6.** A typical land-based system. Note that the pump or intake is located half way between the bottom and surface of the water to avoid surface contaminants and bottom mud.



**Figure 7.** Standpipe construction for both open and closed land-based shedding systems.



**Figure 8.** A crabpot.



**Figure 9.** A bushline with bundles of wax myrtle branches about 15 feet apart, suspended near the bottom by floats.



**Figure 10.** Crab bushlines are checked daily, or during clear water periods, nightly.

# MARINE ADVISORY SERVICE PERSONNEL IN THE LOUISIANA COOPERATIVE EXTENSION SERVICE

## **SPECIALISTS:**

**Dr. Wendell Lorio**, Specialist, Aquaculture  
Louisiana Cooperative Extension Service  
202P Knapp Hall-Louisiana State University  
Baton Rouge, LA 70803-1900  
(504) 388-2152 / FAX (504) 388-2478

**Dr. Gregory Lutz**, Asst. Aquaculture Specialist  
Louisiana Cooperative Extension Service  
202G Knapp Hall-Louisiana State University  
Baton Rouge, LA 70803-1900  
(504) 388-2152 / FAX (504) 388-2478

**Dr. Mike Moody**, Specialist, Seafood Tehnology  
Louisiana Cooperative Extension Service  
202D Knapp Hall-Louisiana State University  
Baton Rouge, LA 70803-1900  
(504) 388-2152 / FAX (504) 388-2478

**Mr. Jimmy Avery**  
Associate Area Agent—Aquaculture  
Louisiana Cooperative Extension Service  
202A Knapp Hall-Louisiana State University  
Baton Rouge, LA 70803-1900  
(504) 388-2152 / FAX (504) 388-2478

## **AREA AGENTS:**

**Mr. Sandy Corkern**  
Louisiana Cooperative Extension Service  
Courthouse Bldg., Room 314  
Franklin, LA 70538  
(318) 828-4100 Ext. 300 / FAX (318) 828-4092

**Mr. David L. Heikes**  
Louisiana Cooperative Extension Service  
Courthouse Bldg., West Wing  
Winnsboro, LA 71295  
(318) 435-7551 / FAX (318) 435-5810

**Mr. Jerald Horst**  
Louisiana Cooperative Extension Service  
1825 Bonnie Ann Drive  
Marrero, LA 70072  
(504) 349-5640 / FAX (504) 349-5645



**Mr. Tom Hymel**

Louisiana Cooperative Extension Service  
P.O. Box 10407  
New Iberia, LA 70562-0407  
(318) 369-4442 or 4437 / FAX (318) 373-0040

**Mr. Dwight Landreneau**

Louisiana Cooperative Extension Service  
P.O. Box 497  
Crowley, LA 70527-0497  
(318) 788-7547 / FAX (318) 788-7568

**Mr. Brian LeBlanc**

Louisiana Cooperative Extension Service  
8201 W. Judge Perez  
Chalmette, LA 70043  
(504) 278-4234 / FAX (504) 271-7343

**Mr. Alan Matherne**

Louisiana Cooperative Extension Service  
P.O. Box 927  
Galliano, LA 70354  
(504) 632-6852 / FAX (504) 632-6703

**Mr. Kevin Savoie**

Louisiana Cooperative Extension Service  
P.O. Drawer H  
Cameron, LA 70631  
(318) 775-5516 / FAX (318) 775-8177

**Mr. Mark Shirley**

Louisiana Cooperative Extension Service  
1105 W. Port Street  
Abbeville, LA 70510  
(318) 898-4335 / FAX (318) 898-4309

**Mr. Paul Thibodeaux**

Louisiana Cooperative Extension Service  
7163 Highway 39, Suite 201  
Braithwaite, LA 70040-9742  
(504) 682-0081 Ext. 2233 / FAX (504) 682-4579

**Matherne/Corkern split assignment**

Louisiana Cooperative Extension Service  
P.O. Box 626  
Houma, LA 70360  
(504) 873-6495