

J. SUPAN

J. HORST

D. BANKSTON

# SOFT-SHELLED CRABS:

Onboard Shedding For Extra Income



LOAN COPY ONLY



# SOFT-SHELLED

# CRABS:

Onboard Shedding For Extra Income

JOHN SUPAN

JERALD HORST

DAVID BANKSTON

LOUISIANA COOPERATIVE  
EXTENSION SERVICE

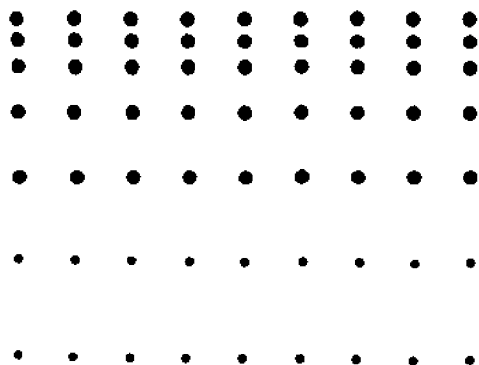

LOUISIANA SEA GRANT COLLEGE PROGRAM  
LSU Center for Wetland Resources  
Baton Rouge, Louisiana 70803

## CONTENTS

<b>Introduction .....</b>	<b>1</b>
<b>Recognizing Shedders .....</b>	<b>2</b>
<b>Tank Design .....</b>	<b>5</b>
<b>Care of the Crabs .....</b>	<b>7</b>
<b>Handling the Crabs .....</b>	<b>7</b>
<b>Storing the Crabs .....</b>	<b>8</b>

## ACKNOWLEDGMENTS

The authors gratefully acknowledge the assistance of Mr. Cultus Pearson, Mr. Noel Usannaz, and Mr. Opie Frey, who shared their own tank designs for the production of this publication.

The crab photographs were provided by Ms. Harriet M. Perry, Gulf Coast Research Laboratory, except for Figure 7, which is courtesy of Dr. Steven Otwell, Florida Sea Grant Marine Advisory Program.

©Louisiana Sea Grant College Program  
Center for Wetland Resources  
Louisiana State University  
Baton Rouge, Louisiana 70803

August 1986

# SOFT-SHELLED CRABS: ONBOARD SHEDDING FOR EXTRA INCOME

John Supan, Jerald Horst,  
and David Bankston

## Introduction

In order to grow, the blue crab must periodically molt, or cast off, its rigid, restricting outer shell. The new, soft shell revealed underneath absorbs water and stretches, allowing the crab to increase in size by about 25 percent. In this soft state, the crab is a special table delicacy, and the entire crab can be prepared in a variety of imaginative ways and eaten shell and all.

For decades, crab fishermen have been producing soft-shelled crabs by holding hard crabs in natural water systems until they molt. Recently, however, closed recirculating water systems have been developed for shedding crabs onshore. The development of onshore holding systems has been of great benefit to the soft-shelled crab industry, particularly in Louisiana, as soft crabs represent a valuable resource. Prices may range from \$12 to \$25 per dozen, and many crab fishermen sell directly to restaurants and consumers.

During the warmer months, shedder crabs are abundant in coastal waters and are often caught by shrimp boats as part of the bycatch. Frequently, shrimpers simply throw these crabs overboard or include them in the hard crab catch, not realizing their potential value. It is feasible, however, for shrimpers to earn extra income by holding the shedders on their vessels until they molt. Onboard tanks can be used for producing soft crabs or for holding hard crabs for later shedding in onshore systems.

Terminology	Sign	Time Before Molting
prepeeler or green crab	white line	6-12 days
peeler or buster crab	pink line red line	2-6 days 1-3 days
buster or cracked crab	cracked shell	within 24 hours

1

## Recognizing Shedders

Shedder crabs--also called "peelers," "busters," and "green crabs"--can be identified by certain color changes in their shells that indicate the length of time until they molt. The most obvious signs are changes in the color of the abdomen (belly), claws, and paddle fins, as well as a darkening in the suture (hinge) lines where the old shell cracks open.

**Paddle fins.** The outer edges of the last two segments of the paddle fins change color. A white line appears (*Figure 1*), caused by the formation of the new shell beneath the old one. This line gradually darkens to a pink line (*Figure 2*) and then to a red line (*Figure 3*) as the new shell continues to form. The red line stage indicates that shedding is about to occur.

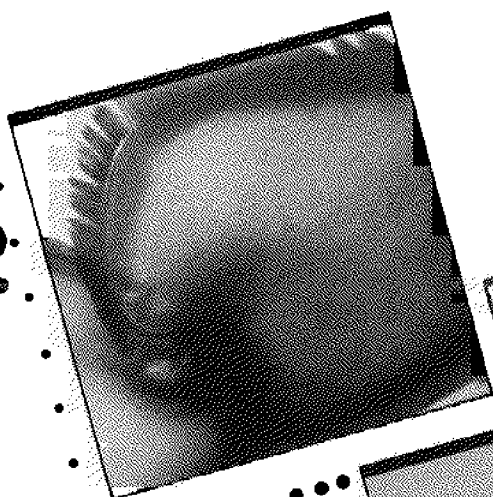

FIGURE 1. White line stage.

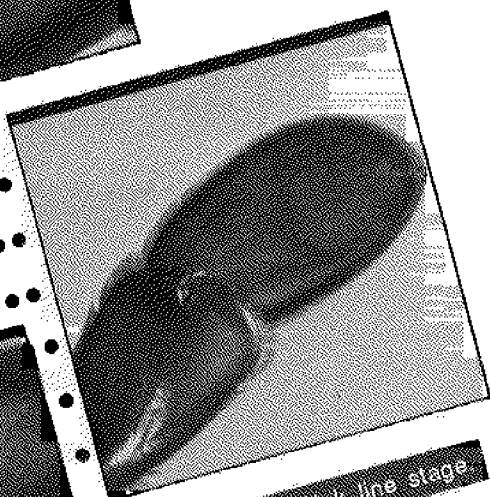

FIGURE 2. Pink line stage.

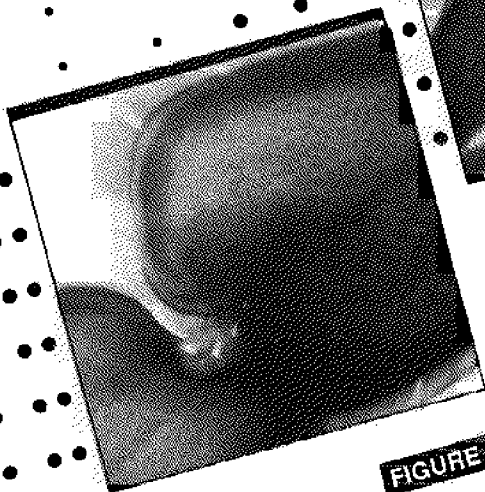

FIGURE 3. Red line stage.

**Abdomen.** Other signs of shedding include changes in the color of the triangular abdomen of the immature female (*Figure 4*) from creamy white to reddish-purple. The abdominal apron of the mature female is round or semicircular. Mature female crabs generally do not molt and should not be kept for shedding.



**FIGURE 4.** Immature female abdomen: intermolt (top) and ripe (bottom)

The abdomens of male crabs turn yellowish before shedding (*Figure 5*). In learning to recognize this sign, it is best to compare the abdomen color of a shedder with that of a newly molted male crab. The shedder also has a new, soft limb bud forming, another sign that shedding is about to occur.

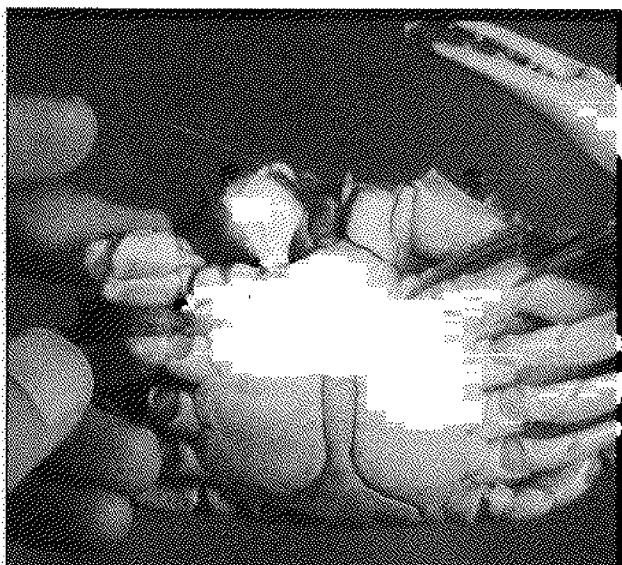

**FIGURE 5.** Male crab with well developed limb bud.

4

**Busters or cracked crabs.** When the soft-shelled crab begins to emerge, the old, hard shell cracks along the back and beneath the "wings" or points (*Figure 6*) and along the suture lines of the claw (*Figure 7*). These crabs shed completely within 24 hours and offer the best turnover and profit potential.

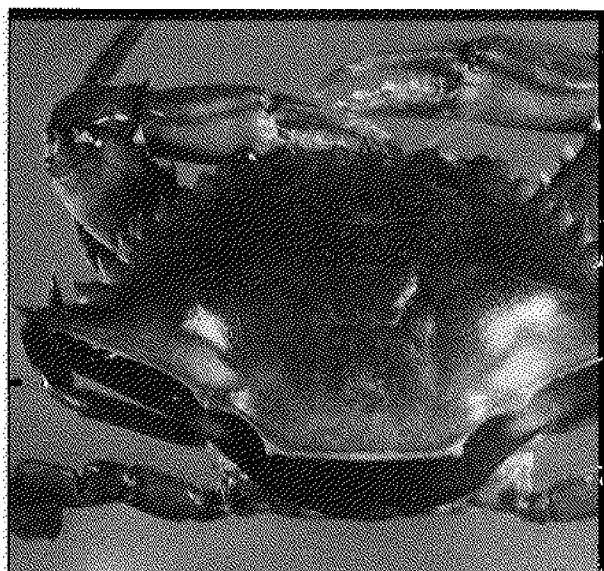

**FIGURE 6.** 'Buster.'



**FIGURE 7.** Cracked claw.

**Other indications.** Other signs include a crab's movements or reactions. For example, when trawls are emptied on the boat's deck, shedder crabs may appear to be less frisky, moving more slowly than hard crabs. They often cover their faces with their claws. The closer a crab is to shedding, the more noticeable this kind of behavior becomes.

## Tank Design

5

A shedding tank can be any size or shape but is usually rectangular for ease of construction. It should be designed for convenient storage on your vessel—out of the way when not in use, but easy to get to when needed.

Tanks used for onboard shedding are basically the same as those used onshore. They may be made of plywood or fiberglass. The sides should be 1 foot high. Onboard tanks may also have a lip on the sides to prevent splashing and loss of crabs.

Cracked crabs or busters should be separated from the other shedder crabs to reduce losses from injury, so the tank should have a divider. The divider should have small holes to allow the tank's water to flow from one side to the other. Hardware cloth or plastic trays work well for this purpose. A plywood or fiberglass sheet with 1-inch holes will also allow water to pass through and reduce splashing, which is especially important on small boats (*Figure 8*).

A tank constructed of wood should be sealed. The side and bottom seams should be sealed on the inside with fiberglass cloth strips and resin for lasting strength. The rest of the inside area should be sealed with a coat of resin, applied with a stiff paint brush. Never use antifouling paint on the tank, as it may kill the crabs. New tanks should be washed well before being used.

A small submersible bilge pump wired to the boat's batteries is commonly used to circulate the water. The water is pumped through a short hose to a capped PVC pipe located along the top of the tank. Holes, 1/8-inch in diameter, spaced



about 2 inches apart on the pipe, spray the water into the tank (Figure 8). The caps on the pipe should be threaded for removal so that the pipe can be cleaned easily. The drain hole at the bottom end of the tank should be large enough to permit quick drainage. A common boat plug used in small recreational boats is a good size for drainage and is available at any marine supply house.

6

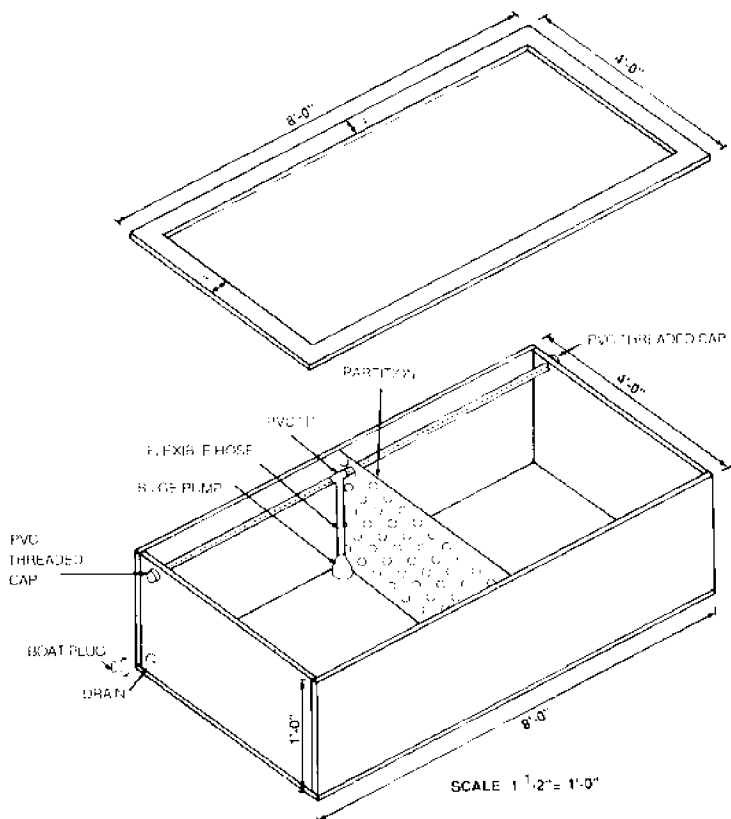

MATERIAL: 1/2" EXTLIGHT PLYWOOD

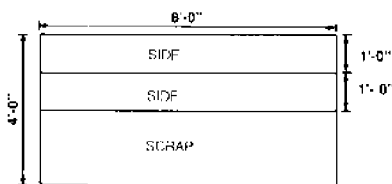
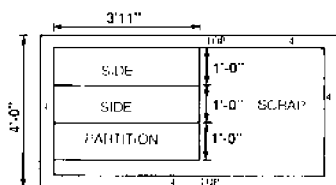
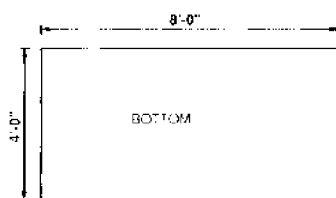

SCALE 1 1/2" = 1'-0"

## Care of the Crabs

**Water quality.** When crabs are held in tanks, good water quality must be maintained. This requires the removal of crab wastes and the maintenance of adequate dissolved oxygen in the water. Crabs produce waste products that can build up to deadly levels in the water. These wastes (mostly ammonia) can be removed by regularly draining the tank and filling it with fresh seawater. How often the water needs changing depends on the number of crabs in the tank, but *the water should be changed at least once a day*. Heavy foaming on the water surface inside the tank is a strong sign of waste build-up and should be prevented with regular water changes.

Oxygen is essential for keeping the crabs alive in the tank and for successful shedding. Crabs remove oxygen from the water that circulates through their gills and this oxygen must be replaced. Using a pump to spray the tank's water through the air is the easiest and most common method of maintaining satisfactory oxygen levels.

Another type of onboard system in use is a flow-through tank. Water is continuously pumped through the tank and discharged overboard. To reduce priming problems, a submersible pump is used for this purpose. Make sure that the pump's intake isn't located near the boat's bilge outlet.

## Handling the Crabs

When a crab is about to shed, it is undergoing great stress. Poor handling can cause death. Do not damage the crabs by dropping them or throwing them about, exposing them to oil, fuel, or fumes, or puncturing their shells with tongs or other handling tools.

Shedder crabs in the early stages of the molting process (the prepeeler or green crabs) will eat those in the later stages, so cracked or buster crabs should be separated from the others to reduce losses from cannibalism. To do this, the crabs should be "graded," or inspected, daily and the cracked crabs removed. The tank compartment holding the cracked crabs should be checked every 3 hours for newly molted soft-shelled crabs.

After molting, a soft-shelled crab usually expands to its full size within about an hour, though length of time depends on the size of the crab and the water temperature. When a crab has expanded to full size, it should be removed from the water to keep the new shell from hardening.

If a crab is left in the water too long after molting, its shell begins to harden, leaving a "papershelled" crab of far less value. Water temperature determines how fast a crab's shell hardens--the warmer the water, the faster it hardens.

## Storing the Crabs

Proper storage of soft-shelled crabs is essential for good quality and, therefore, top prices. If you have a freezer on board, tightly wrap the crabs individually in plastic wrap and store them face up. This helps to keep water from draining out of the crabs. If a freezer isn't available, place the crabs in a single layer, face up, in a cardboard "beer flat." Place these flats on ice in the hold or ice box. Don't stack the flats on top of one another, or the crabs will be crushed. Never place the crabs in direct contact with ice.

### MATERIALS LIST FOR A PLYWOOD TANK, 4 X 8 X 1 FEET

NO.	ITEM
3	4' x 8' x 1/2" sheet exterior grade plywood ( <i>Figure 8</i> )
1	small bilge pump or other submersible pump
1	12" length of flexible hose
2	hose clamps
2	4' lengths of 1" PVC pipe (the diameters of pipe and flexible hose depend on the pump's water-outlet size and should be chosen accordingly)
1	PVC "T" fitting, same size as pipe
2	PVC male and female threaded fittings, same size as pipe
1	small can PVC glue
2	quarts resin and hardener
	30 feet of 2" fiberglass cloth
	galvanized nails
1	boat plug (for drain)

A tank of this size will hold about 200 crabs. The more crabs put into the tank, the more often the water needs to be changed. If you want to hold more crabs, build another tank. Before using the tank for the first time, flush it. To do this fill with water and turn on the pump. Allow the pump to run for a few hours and then drain the tank. This procedure removes harmful chemicals that leach out of the fiberglass, resin, and pipe glue.

NATIONAL SEA GRANT DEPOSITORY  
PELL LIBRARY BUILDING  
URI, NARRAGANSETT BAY CAMPUS  
NARRAGANSETT, RI 02882

RECEIVED  
NATIONAL SEA GRANT DEPOSITORY

DATE: OCT 14 1988

