

**CIRCULATING COPY**  
**Sea Grant Depository**

ORES-U-H-75-001

C. 2



# **Netarts Bay Chum Salmon Hatchery**

**an experiment in  
ocean ranching**

**James E. Lannan**

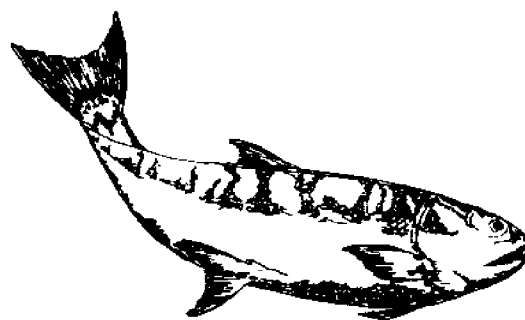

**OREGON STATE UNIVERSITY  
SEA GRANT COLLEGE PROGRAM**

Publication no. ORESU-H-75-001

**AGRICULTURAL EXPERIMENT STATION**  
Station Bulletin no. 621

**NOVEMBER 1975**



# **Netarts Bay Chum Salmon Hatchery**

**an experiment in  
ocean ranching**

**James E. Lannan**

**OREGON STATE UNIVERSITY  
SEA GRANT COLLEGE PROGRAM**

Publication no. ORESU-H-75-001



**AGRICULTURAL EXPERIMENT STATION**

Station Bulletin no. 621

**NOVEMBER 1975**

## author

JAMES E. LANNAN is Assistant Professor of Fisheries and Wildlife at Oregon State University.

## acknowledgment

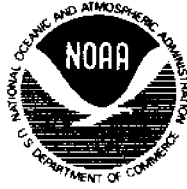

The Oregon State University Sea Grant College Program is supported cooperatively by the National Oceanic and Atmospheric Administration, U.S. Department of Commerce, by the State of Oregon, and by participating local governments and private industry.

## product names

Products and suppliers are mentioned for clarity. Mention of a trademark name or a firm does not constitute endorsement. The company and trademark names mentioned in this publication supplied products actually used at the Netarts Bay hatchery facility. No criticism is implied of firms not mentioned.

## related publications

**NORTHWEST MARICULTURE LAWS: PAPERS AND PRESENTATIONS FROM A SYMPOSIUM HELD AT THE LAW CENTER, UNIVERSITY OF OREGON, EUGENE, JUNE 7, 1974.** Publication no. W-74-005. (Price: \$2.00) 31 pp.

Proceedings of a symposium which examined the legal implications of the growing interest in mariculture and focused discussion on the laws, new and old, that affect the establishment and operation of mariculture businesses.

**HATCHERY MANUAL FOR THE PACIFIC OYSTER**, by Wilbur P. Breese and Robert E. Malouf. Publication no. H-75-002.

Explains the tools and techniques tested and adopted at the Oregon State University Pilot Oyster Hatchery. It is a "how-to" manual covering all phases of raising oyster seed—from selecting and conditioning adult spawners, to feeding and raising larvae, to culturing algae for oyster food and preparing tanks for setting.

## ordering publications

Copies of these and other Sea Grant publications are available from

Sea Grant Communications  
Oregon State University  
Corvallis, Oregon 97331

Please include author, title and publication number. Some publications carry a charge to help defray printing expenses. The charge, if any, appears after the publication number.

Please make checks payable to Oregon State University.

CONNIE MOREHOUSE: illustrator

## **contents**

Introduction	5
Background information	6
Planning the ocean ranching hatchery	7
Description of Netarts Bay hatchery	12
The hatchery routine	23



The recent pattern in Pacific salmon fisheries is one of overcapitalized vessels, facing escalating energy and labor costs, in pursuit of limited (in some cases decimated) stocks. In many areas of the Pacific Northwest, the fisheries depend heavily upon exploiting artificially propagated stocks. Since revenues from the fisheries do not offset the costs of hatchery programs, the propagative programs of state and federal agencies are a subsidy without which the fisheries could not exist. The fisheries are also dependent on market prices which place ocean-caught salmon in the luxury food class. The problems confronting the fisheries have resulted in increasing interest in salmon aquaculture as an alternative approach to salmon production.

One contemporary approach to the culture of Pacific salmon favors a very intense culture analogous to the feed lot concept of livestock production. Salmon are propagated in hatcheries and reared at high densities in impoundments or floating pens to marketable size. Because of the very high production costs associated with this type of culture, the product must be of sufficiently high quality to command a premium market price. Complex facilities are required and a significant labor expenditure is associated with intensive culture. Pacific salmon are at the highest trophic level and require a diet comprised largely of animal protein. Adequate rations are very expensive. Rearing the fish at high densities leaves the crop vulnerable to outbreaks of infectious diseases.

Extensive marine aquaculture, popularly referred to as ocean ranching, provides an attractive alternative to intensive feed lot culture. Pacific salmon lend themselves well to extensive production concepts. They can be propagated efficiently and economically in hatcheries, released to "graze" at sea and harvested either in an ocean fishery or upon their return to the natal stream.

The term ocean ranching has been used to describe a number of production concepts employing varying degrees of culture intensity. For example, the artificial propagation of salmon to augment offshore fisheries is considered to be a form of extensive aquaculture even though it may be intensive in the early stages. In the subsequent sections of this report the term ocean ranching will be used in a restricted sense to describe a specific production concept. This concept involves the production of chum salmon fry in an incubation system designed specifically for this purpose, the direct release of these unfed fry and the harvesting of mature fish upon their return to the natal facility. This is among the least intensive approaches to fish production with respect to capital, labor and operating expenses. As such, it is a promising approach to large scale production of low cost aquatic animal protein.

# background information on the netarts bay project

---

The potential for the application of the ocean ranching concept to the production of salmon has been recognized at least since the 19th century. However, it has not been conclusively demonstrated that there is indeed a sound biological and economic basis for commercial salmon production through ocean ranching.

In 1969, Dr. William McNeil, then associate professor of fisheries at Oregon State University, initiated a project to develop an incubation system for the production of chum and pink salmon fry. Working at Netarts Bay on land donated to the University by the Victor Swanson family, he and his student, Derek Poon, constructed a prototype gravel incubator hatchery. Their experiments led to the development in 1971 of what is now known as the Netarts gravel incubation system. They tested this system on a production scale during the fall of 1971. The results of this test indicated that the Netarts gravel incubation system was capable of producing fry of reasonable quality efficiently and economically and the system ap-

peared to be suitable for industrial production.

During the summer of 1972, Dr. McNeil left Oregon State University to accept a position in Alaska. Project leadership was assumed by the author.

Dr. McNeil's activities at Netarts Bay occurred during an era of increasing interest in commercial salmon production in Oregon. This interest led to the enactment in 1971 of legislation which allowed the commercial production of chum salmon in Oregon.

The selection of chum salmon as the first species for which private production would be allowed in Oregon was by no means an arbitrary decision. The decision was based upon biological, economic and public interest considerations. For example, while coho and chinook salmon are exploited in both commercial and recreational fisheries on the Oregon coast, chum salmon are not exploited to any large degree. Further, the markets for chum salmon differ from the other species. Therefore, the production of chum salmon by commercial ocean ranching does not place the producer in com-

petition with existing fisheries. This benefits both the fisheries and the ocean ranchers since fish released from private hatcheries are fair game for sport and commercial fishermen during the ocean phase.

Certain aspects of the biology of chum salmon make this species well suited for commercial production. For example, chum salmon fry are capable of adapting to seawater by the time yolk utilization is complete. Coho and chinook salmon, on the other hand, require an extended fresh water rearing phase before they are capable of seawater adaptation. The selection of chum salmon for ocean ranching relieves the producer of the expense of feeding juvenile fish and eliminates the requirement for fresh water holding facilities.

By the end of 1971, the Fish Commission of Oregon had licensed two commercial chum salmon hatcheries and had received applications for hatchery permits from several other parties. In 1972, the primary limitations to the further development of a chum salmon producing industry in Oregon were two-fold. First, the capitalization of an ocean ranching enterprise was highly speculative since commercially adequate returns had not been demonstrated. Second, eggs were not available for establishing private hatchery stocks of chum salmon. What was needed then was a demonstration project directed towards the following objectives: (1) to test and demonstrate the technology of producing chum salmon through extensive aquaculture, (2) to assess the economic feasibility of such production, and (3) to establish an egg source from which commercial producers would be able to obtain gametes. In response to this need, chum salmon have been propagated at Netarts Bay each year since 1972. Subsequent sections of this booklet describe the concepts, facilities and methods employed at Netarts Bay in satisfying the demonstration project objectives.

# planning the ocean ranching hatchery

## General Considerations

The majority of expenses incurred in ocean ranching is related to hatchery operations, including trapping and harvesting. The ocean ranching hatchery functions to produce large numbers of fry at minimum cost. The ideal ocean ranching hatchery is conceived as one representing a very modest capital outlay in which labor intensity is minimal and maximum reliability in all hatchery systems is achieved. It follows that the degree to which an ocean ranching endeavor is profitable may be largely determined during the planning stages. In addition to carefully planning the development of the hatchery itself, hatchery site selection and legal problems must be considered.

The major labor expenditures in the ocean ranching hatchery occur during the process of trapping fish and during subsequent spawning operations. The facilities utilized in these operations should be designed to streamline these processes and thus minimize labor intensity. The remainder of the production cycle is conceived to be a hands-off operation. The only labor expenditure here is in routine hatchery inspection and maintenance. The labor expenditure can be minimal if all hatchery systems perform reliably.

The reliability of hatchery systems is dependent on the hatchery water supply system. A reliable water supply system is absolutely essential. Reliability in this sense means that the incubation system is provided with an adequate quantity and quality of water at all times. This may impose a requirement for back-up systems and alarm systems. However, the most dependable system is not necessarily the most sophisticated system. In many instances, one may avoid mechanical failures and reduce capital expenditures by avoiding sophistication. This is the preferred practice when it can be done without compromising the dependability of the water supply.

## Selection of the Hatchery Site

The first consideration in the selection of the hatchery site is, of course, the hatchery stream. The selection of a hatchery stream will typically be dictated largely by availability. However, should a commercial enterprise have more than one stream from which to select, some general considerations should direct this selection.

The reproductive strategy and behavior of the species are such a consideration. Chum salmon fry are subject to predation by a variety of organisms, including other species of salmonid fishes. Their reproductive strategy has been to exploit streams in which they are least likely to be faced with this predation. Because chum salmon fry migrate into estuarine nursery areas almost immediately after emergence, they can utilize spawning areas in which other species of salmonids could not survive. Specifically, they are adapted to exploit the sorts of coastal streams which manifest minimal summer stream flows and high summer temperatures. These streams are not suitable for the reproduction of many salmonid species because of the extended fresh-water juvenile stage of those species. Chum salmon can enter these streams, deposit their seed after early autumn freshets, and the subsequent generation emerges and migrates out of the stream the following spring before stream conditions become critical. An ocean ranching hatchery situated on this type of stream would probably experience less severe predation than one located on a stream which supported natural populations of predators.

Juvenile chum salmon exploit estuarine nursery areas during the course of their ocean migration. It is not surprising that the most productive chum salmon streams are in close proximity to an estuary. Streams with very severe gradients are less likely to be productive chum salmon habitats than streams with gentle gradients. Unlike other salmonid species, chum salmon

appear reluctant to negotiate turbulent waters during their spawning migration, especially if this migration would require movement over obstacles. It is more the nature of chum salmon to attempt to burrow under an obstacle than go over it.

Another factor underscoring the desirability of hatchery sites in close proximity to an estuary for the production of chum salmon relates to the optimum location of the trapping facility. The site selected for the ocean ranching trap should be as near to the ocean or estuary as possible. This location is dictated by two considerations. First, if there is suitable spawning habitat downstream of the trap, mature fish will take advantage of that habitat. The eggs deposited in that area are no longer available to the production hatchery. Second, the flesh quality of the mature fish deteriorates rapidly once the fish enter fresh water and commence their courtship. Both these problems are avoided if the fish are trapped as soon as they begin to explore the natal stream.

Legal considerations relating to the hatchery site will be discussed in another section. Other questions which should be considered during site evaluations include whether the site is of sufficient area to accommodate the ultimate level of production projected and whether the site can be developed in such a way as to insure security in the face of inclement weather, high tides and stream flows, and vandalism. Finally, the site obviously must lend itself to the development of a suitable hatchery water system, a functional hatchery layout and adequate harvest facilities.

## Selection of an Egg Source

The preferred source of eggs for developing a stock of chum salmon for a commercial hatchery is from fish native to the hatchery stream. These fish would be expected to be genetically adapted to that environment. If a stock of chum salmon exists in the hatchery stream, it is necessary to ob-



tain permission from the appropriate state regulatory agencies before taking eggs. If a stock of fish does not exist in the hatchery stream, or if permission to take eggs cannot be obtained, then it will be necessary to import eggs to establish a hatchery stock.

If the hatchery stream contains a stock of chum salmon but eggs are imported because permission was not granted to take eggs from the native stock, it may be possible to obtain permission to harvest sperm from native fish and use this sperm to fertilize the imported eggs. In this way a hybrid stock is established which would be expected to be better adapted than a totally imported stock.

It may be necessary to import both eggs and sperm. If so, a decision must be made as to where the eggs and sperm will be obtained. This decision may be dictated to a large degree by

the fishery regulations of the appropriate states. The present discussion will be limited to considering the circumstances facing private hatchery operators in Oregon.

In Oregon, the policies of the Department of Fish and Wildlife require private hatcheries between Cascade Head and the mouth of the Columbia River to use only eggs from within this geographical region. Private hatcheries outside this zone may utilize eggs from any approved source.

Among the considerations which should be addressed in evaluating an egg source are how well the donor stock might be adapted to the recipient environment and the disease status within the range of the donor stock. With respect to the question of adaptation, it is not generally possible to determine before the fact how fish derived from a given stock will perform when introduced into a foreign environment. In general, however, one might expect fish or eggs from a nearby region to manifest better performance than those from a more distant source. For example, eggs from another Oregon coastal site would be a better selection than eggs from the Puget Sound region.

The inadvertent introduction of fish diseases into a hatchery stream is an always present danger. Once a disease is introduced, it may be virtually impossible to eliminate. This is especially true for viral diseases of fishes.

The danger of introducing viral diseases is especially great. Evidence has been presented which indicates that these diseases may be transmissible through the eggs. To get a permit to transport fish eggs into Oregon, it is necessary to obtain a certification from a qualified fish pathologist that not only the eggs but also the parents from which they were derived are free from viral diseases. As a consequence of these regulations, salmon eggs brought into Oregon for propagative purposes must be fertilized at the point at which they are taken and incubated outside the state until the

pathologist's laboratory tests have been completed. The costs associated in obtaining this certification must be borne by the applicant. Because of the very real danger of introducing viral diseases to the Oregon coast, where they have not been reported to date, private hatchery operators should make every attempt to obtain eggs from an Oregon source before turning to sources outside the state.

### **Legal Considerations**

The legal considerations encountered in developing a commercial hatchery depend largely on the internal organization of the producing firm, relationships with land owners, and so on, and therefore will vary from one situation to another. However, there are certain legal considerations which are applicable to any commercial hatchery and are appropriately considered here.

The first consideration relates to water rights. Water rights can be obtained for the beneficial use of unappropriated waters and are subject to existing rights. Whether unappropriated water is available for utilization in the ocean ranching hatchery should be determined during the process of site selection. In Oregon, applications for water rights are processed by the Office of the State Engineer, Salem, Oregon 97310. This agency also regulates the development of hatchery intakes and other water diversion facilities.

A permit to operate a private hatchery must be obtained from the state in all states where private production is permitted. In Oregon, private salmon hatchery permits are issued by the Department of Fish and Wildlife. Prospective applicants may contact coastal agents or write to the Research and Management Division, Department of Fish and Wildlife, 17330 S.E. Evelyn, Clackamas, Oregon 97015. In addition to the salmon hatchery permit required for ocean ranching, a Wildlife Hatchery License is required for intensive fish rearing. This license

<i>Type of Permit</i>	<i>Responsible Agency</i>
Water rights	Office of the State Engineer Salem, Oregon 97310
Private hatchery permit	Research and Management Division Oregon Department of Fish and Wildlife 17330 S.E. Evelyn Clackamas, Oregon 97015
Importation of fish or fish eggs	Oregon Department of Fish and Wildlife P. O. Box 3503 Portland, Oregon 97208
Pollutant discharge	Department of Environmental Quality 2595 State Street Salem, Oregon 97310
Building permit; land use approval	appropriate local agencies
Works in navigable waters	District Engineer U.S. Army Engineer District, Portland P. O. Box 2946 Portland, Oregon 97208 and Director Division of State Lands 1445 State Street Salem, Oregon 97310
Wildlife hatchery license	Oregon Department of Fish and Wildlife P. O. Box 3503 Portland, Oregon 97208
Clearance to sell fish and fishery products	Department of Agriculture Salem, Oregon 97310

**Table 1. Checklist of permits required for private hatcheries in Oregon.**

may be obtained from the Department of Fish and Wildlife, P.O. Box 3503, 3503, Portland, Oregon 97208.

The transportation of fish and fish eggs across state lines is regulated by the states concerned. A permit must be obtained to import fish or fish eggs into Oregon. Applications for this permit should be directed to the Department of Fish and Wildlife, P.O. Box 3503, Portland, Oregon 97208.

Many fish hatcheries are now required to obtain a National Pollutant Discharge Elimination System Permit. The feeding of juvenile fish in hatcheries may result in increased organic pollutants in the discharge water. Although the hatchery discharges from ocean ranching hatcheries are relatively clean, private hatchery operators are advised to apply for a pollutant discharge permit before commencing production. In Oregon, dis-

charge permits are administered by the Department of Environmental Quality, 2595 State Street, Salem, Oregon 97310.

A building permit may be required for the development of a private hatchery and the proposed land use may be subject to local zoning regulations. Private hatchery operators should consult with appropriate local agencies to determine whether such permits are required.

The development of a private hatchery may involve work in navigable waters. Navigable waters are defined as waters which run between the ordinary high water lines of river banks and between the mean higher high water lines of estuary banks. Permits are required to undertake construction in navigable waters. In the case of the ocean ranching hatchery, this means a permit may be required for

stream bank stabilization, installation of the trapping facility and possibly for the construction of the water diversion structure associated with the hatchery water system. Requests for information relating to permits to work in navigable waters should be directed to the District Engineer, U.S. Army Engineer District, Portland, P. O. Box 2946, Portland, Oregon 97208. In addition to the permit from the Corps of Engineers, the State of Oregon requires that a permit be issued by the Division of State Lands, 1445 State Street, Salem, Oregon 97310.

The sale of fish and fishery products is regulated by the state. In Oregon, clearances to sell fish are administered by the State Department of Agriculture, Salem, Oregon 97310.

A checklist of permits required to operate a private hatchery in Oregon is presented in Table 1.



# description of the netarts bay hatchery

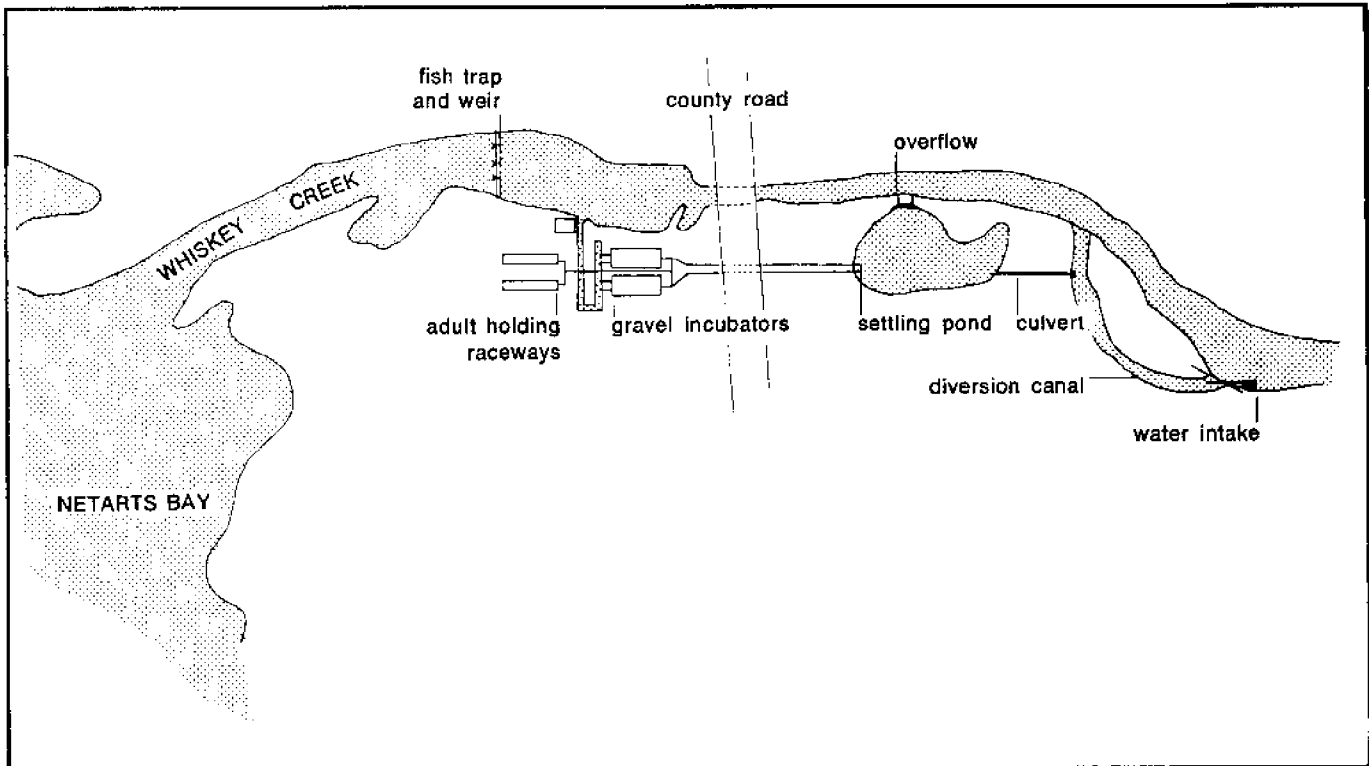

Fig. 1. Overview of Netarts Bay hatchery.

Physically, the Netarts Bay hatchery is composed of five systems: the trapping facility, the adult holding raceway, the spawning area, the Netarts gravel incubator and the hatchery water supply. The layout of these components at Netarts Bay is shown in Fig. 1.

Descriptions and construction details for the five components follow. Some modification may be necessary to adapt these designs to other hatchery sites.

## The Netarts Gravel Incubation System

At the heart of the Netarts hatchery is the Netarts gravel incubation system.

Numerous implements have been developed for the purpose of hatch-

ing trout and salmon eggs. All of these systems have a common denominator: a means of passing clean, oxygenated water past developing eggs until the eggs have hatched and the developing alevins have utilized their supply of yolk. It should be recognized at the outset that the Netarts gravel incubator is another permutation of this principle. It is a permutation which, owing to its efficiency and economy, is ideally suited for ocean ranching.

## The Evolution of Gravel Incubators

During the exploratory stages of the artificial propagation of Pacific salmon, it was found that incubation techniques which had been developed for the propagation of trout lent themselves well to the propagation of some,

but not all, species of Pacific salmon. Specifically, these techniques did not lend themselves to the propagation of pink and chum salmon. Alevins of the latter species were frequently observed to develop abnormally. It was subsequently learned that these abnormalities could be prevented by providing the alevins of chum and pink salmon with a substrate upon which or within which they could repose during the period of yolk utilization. In nature, of course, the stream bed gravel serves this purpose. This generalization prompted fish culturists to experiment with the utilization of gravel in conjunction with conventional egg incubation techniques.

The earliest approaches taken to the development of gravel incubators concerned themselves with attempting

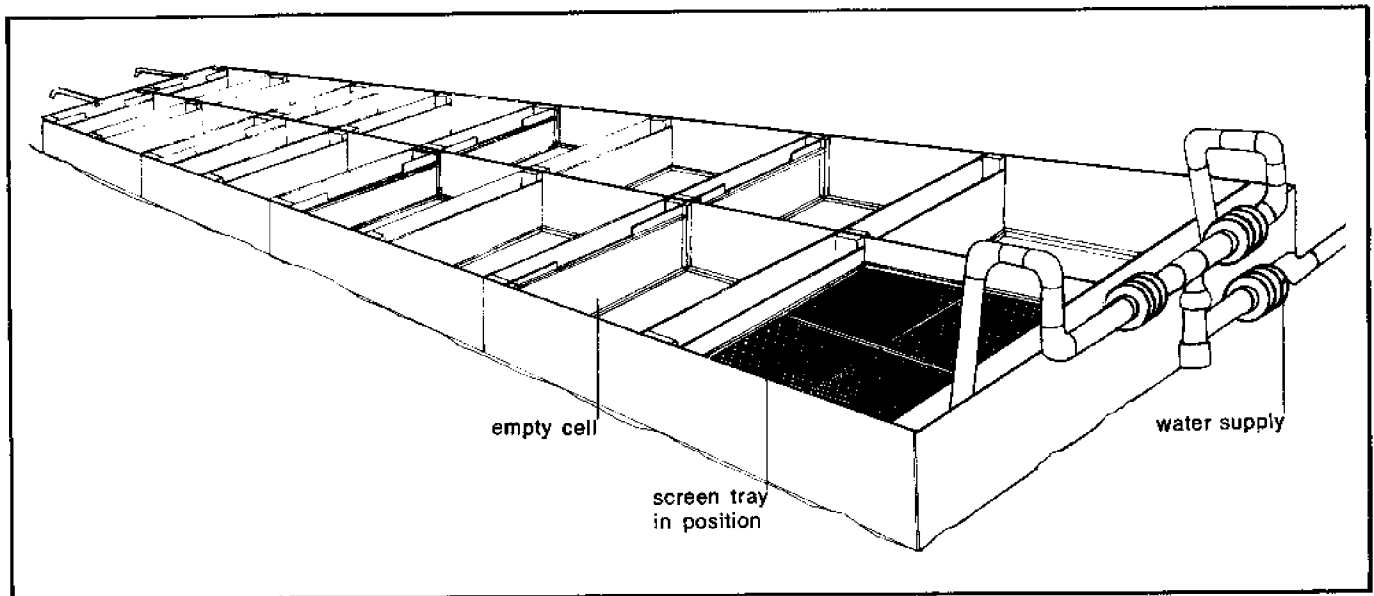

Fig. 2. Incubator modules arranged in a linear array.

to simulate the incubation environment found in nature. These investigations culminated in the development of the upwelling gravel incubator by Robert Bamms of the Fisheries Research Board of Canada.

In upwelling incubation systems, fertilized salmon eggs are placed within a deep bed of gravel. Water is introduced under pressure at the base of the gravel layer and forced up through the gravel layer containing the eggs. The eggs hatch within the gravel and the alevins reside in the gravel during the period of yolk utilization. When yolk utilization is complete, the fry emerge from the gravel.

The upwelling gravel incubator has been shown to produce a fry of high quality relative to other incubation techniques. However, there are certain operational aspects associated with this incubation system which make it less than well suited for the propagation of salmon fry for ocean ranching. First, water must be introduced under the gravel layer. This may require the use of pumps, precluding the use of gravity flow water

systems. Second, because of the filtration properties of the deep gravel bed, the hatchery water system must be essentially free of silt throughout the incubation period. At many hatchery sites this would require filtration of the hatchery water prior to introduction to the incubator. Finally, seeding the incubator is a labor intense operation. Relatively large quantities of gravel are required, and must be placed in the incubators concurrent with placing the eggs in the incubators. Upwelling incubators typically use from 12 to 15 cubic yards of gravel per million eggs.

The development of the Netarts gravel incubator resulted from the efforts of Dr. McNeil and his colleague, Derek Poon, to circumvent the problems attendant with operating an upwelling gravel incubator. Their design resulted from their observation that fry of reasonable quality could be produced by placing alevins upon a gravel substrate instead of within it and passing water over the gravel instead of upwelling through it. Working around this generalization, they proceeded to

optimize the design of the incubation system with respect to the following criteria: (1) the incubator must be of a simple design and easily constructed from readily accessible materials, (2) labor intensity associated with operating the incubation system should be minimal, and (3) the water flow requirements of the incubation system should permit the utilization of gravity flow water systems without requiring prefiltration of the incubator water.

#### Description of the Netarts Gravel Incubator

The basic Netarts gravel incubator module is a box measuring 4 x 8 x 1½ feet deep. The box is comprised of two incubation cells and a system of water diversion baffles. Up to eight modules (i.e., 16 cells) can be arranged in a linear array (Fig. 2). Water is introduced into the water intake compartment at the upstream end of each module. The water intake compartment is separated from the incubation cell by a water intake baffle. Water is forced to flow under the water intake baffle, entering the incu-

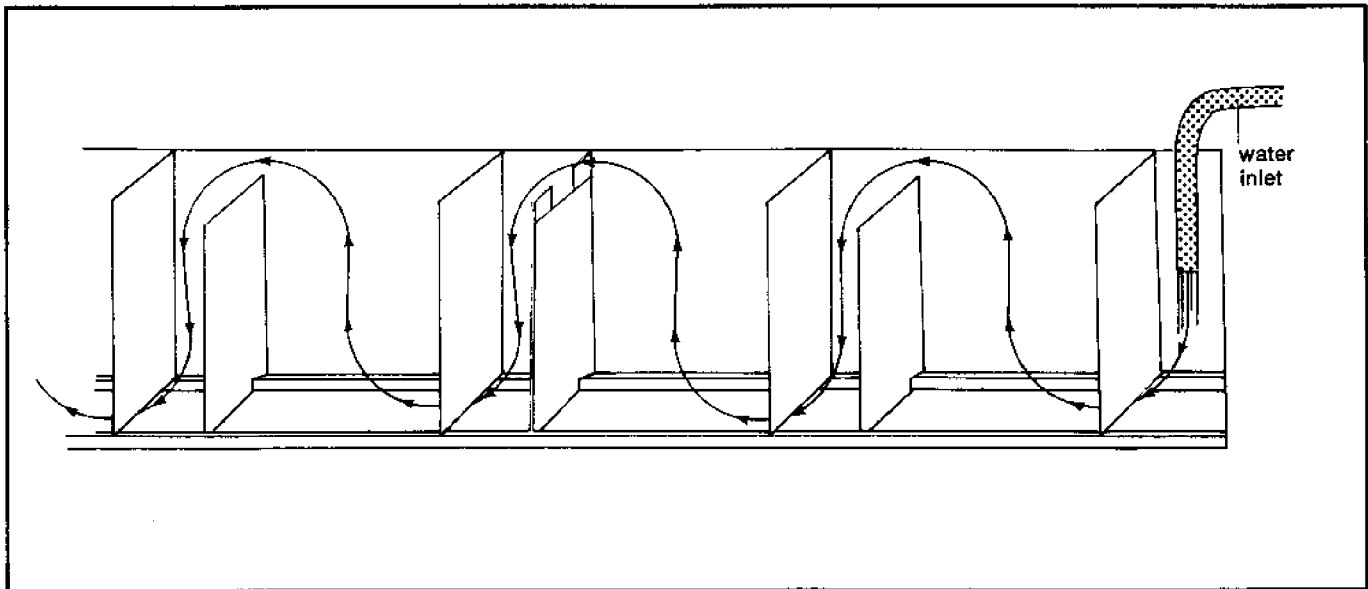

Fig. 3. Water flow through Netarts Bay incubator. Baffles insure mixing and prevent stratification.

bation cell at the bottom of the upstream side. Water then circulates up and through the incubation cell and spills over the water outlet baffle into the water intake chamber of the next cell (Fig. 3). A bed of washed, graded gravel one to two inches deep is placed in the bottom of each incubation cell. Crushed rock graded from  $\frac{1}{8}$  inch to  $\frac{3}{8}$  inch has been found to be satisfactory for this purpose. Approximately two cubic feet of gravel are required for each cell.

Fertilized salmon eggs are placed on screen trays suspended above the gravel (Fig. 4). The trays are made from Vexar® 60CDS49BK, a DuPont thermoplastic netting. A mesh size of  $\frac{1}{8}$  inch is satisfactory for the incubation of pink salmon eggs and a mesh size of  $\frac{1}{4}$  inch is satisfactory for the incubation of chum salmon eggs. Four trays are placed in each cell (Fig. 5). Each tray is seeded with approximately 10,000 fertilized eggs. The optimum loading for each cell is based on the available gravel area and not on the total screen area.

During incubation of the eggs,

water is introduced at the bottom of the upstream end of the incubation cell and flows upward through the eggs resting on the screens. After hatching, alevins find their way through the screens and ultimately come to rest on and within the gravel in the bottom of the cell, where they remain until utilization of the egg yolk is completed. When hatching is complete and all of the alevins have found their way to the gravel, the egg support screens are removed from the incubation cells. When the fry are ready to commence their downstream migration, their way to the outlet pipe at the downstream end of the row of incubator modules is unrestricted.

The incubators in use at the Netarts hatchery were constructed from  $\frac{3}{4}$  inch exterior grade plywood. Alternate materials might include fiberglass, other non-toxic plastics or concrete. Construction details are shown in Figs. 6 and 7 and Table 2.

The cover is an important part of the incubator module. It has been shown that fry of superior quality result when embryos and alevins are in-

cubated in the absence of light. The covers at the Netarts hatchery are uncut 4 x 8-foot sheets of plywood, painted on both sides, and fitted with guide strips on the under surface which prevent lateral displacement. The covers are secured with screen-door hooks.

During assembly of the incubators for the Netarts hatchery, caulking compound was applied to all adjoining surfaces. After closure of the joints, excess caulking compound was carefully removed.

Interior and exterior finishing extends the useful life of the incubators and simplifies cleaning and maintenance. One must exercise caution in selecting only non-toxic finishes. At the Netarts hatchery, the exteriors of the incubators are painted with exterior latex housepaint. The interiors are painted with lead-free exterior enamel (hatchery white).

Joining the incubator modules securely into tandem units is easily accomplished. The modules are placed in the desired position and  $\frac{3}{8}$  inch holes are match-drilled through both

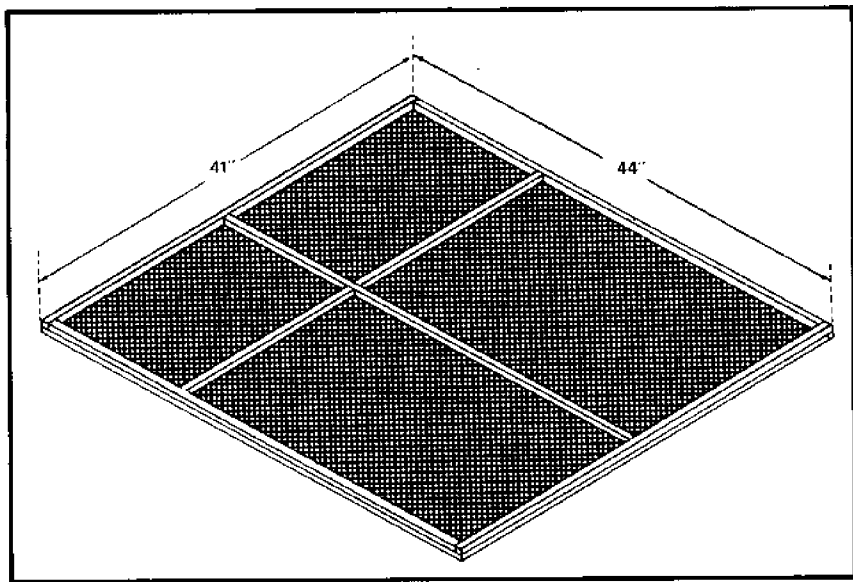

Fig. 4. Screen tray used to hold salmon eggs. Crossbars should be offset randomly to avoid partitioning water flow in the cell. See Table 2 for materials list.

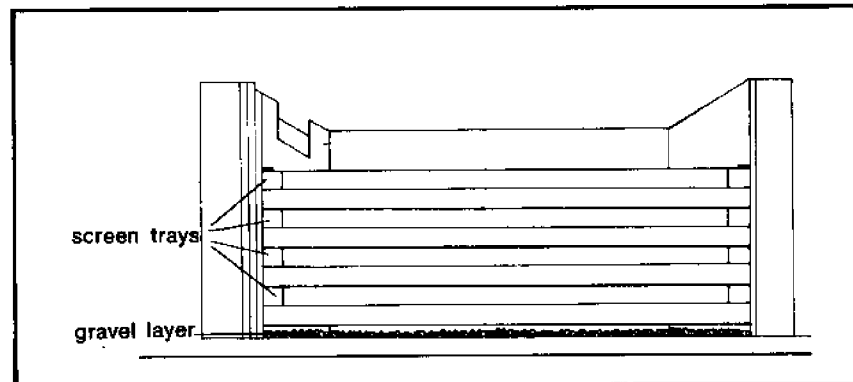

Fig. 5. View of Netarts Bay incubator cell with side removed, showing all screen trays in place. Screens are held in place by removable pegs fixed to the corners of the incubator. Since screen trays float when the incubator is filled with water, the pegs are placed above the trays.

Reference	Description	Number Required
Fig. 4	$\frac{3}{8}$ " or $\frac{1}{2}$ " mesh VEXAR® 60-CDS cut to 41" x 44 $\frac{1}{2}$ "	1 per tray
Fig. 4	$(\frac{1}{2}) \times (\frac{1}{2})$ , for tray frames	43 lin. ft. per frame
Fig. 6		
#1	bottom: 48 x 96 x $\frac{3}{4}$	1
#2	side: 16 x 96 x $\frac{3}{4}$	2
#3	end: 16 x 46 $\frac{1}{2}$ x $\frac{3}{4}$ (3" x 32" cutout, centered) (End pieces for modules at end of a series of modules may differ; see Figs. 6 and 7.)	2
#4	inlet baffle: 14 $\frac{1}{2}$ x 46 $\frac{1}{2}$ x $\frac{3}{4}$ (bottom rests on stringer to allow water flow under baffle)	2
#5	outlet baffle: 13 x 46 $\frac{1}{2}$ x $\frac{3}{4}$ (lower corners notched for stringers)	1
#6	stringer: $(1\frac{1}{2}) \times (1\frac{1}{2}) \times 94\frac{1}{2}$	2
#7	baffle/end support, horizontal: $(1\frac{1}{2}) \times (1\frac{1}{2}) \times 43\frac{1}{2}$	5
#8	corner post: $(1\frac{1}{2}) \times (1\frac{1}{2}) \times 14\frac{1}{2}$	2
#9	baffle support: $(1\frac{1}{2}) \times (3\frac{1}{2}) \times 14\frac{1}{2}$	4
Fig. 7	3" flange or bulkhead fitting, PVC	1 per line of incubators
Fig. 7	1 $\frac{1}{2}$ " flange or bulkhead fitting, PVC	1 per line of incubators
Fig. 7	3" elbow, PVC	1 per line of incubators
Fig. 7	1 $\frac{1}{2}$ " elbow, PVC	1 per line of incubators
Fig. 7	3" PVC pipe	to suit installation
Fig. 7	1 $\frac{1}{2}$ " PVC pipe	to suit installation

Dimensions in parentheses denote actual dimensions of dimension lumber. E.g.,  $(1\frac{1}{2})$   $(1\frac{1}{2})$  denotes 2 x 2 dimension lumber.

Table 2. List of materials for Netarts Bay gravel incubator.

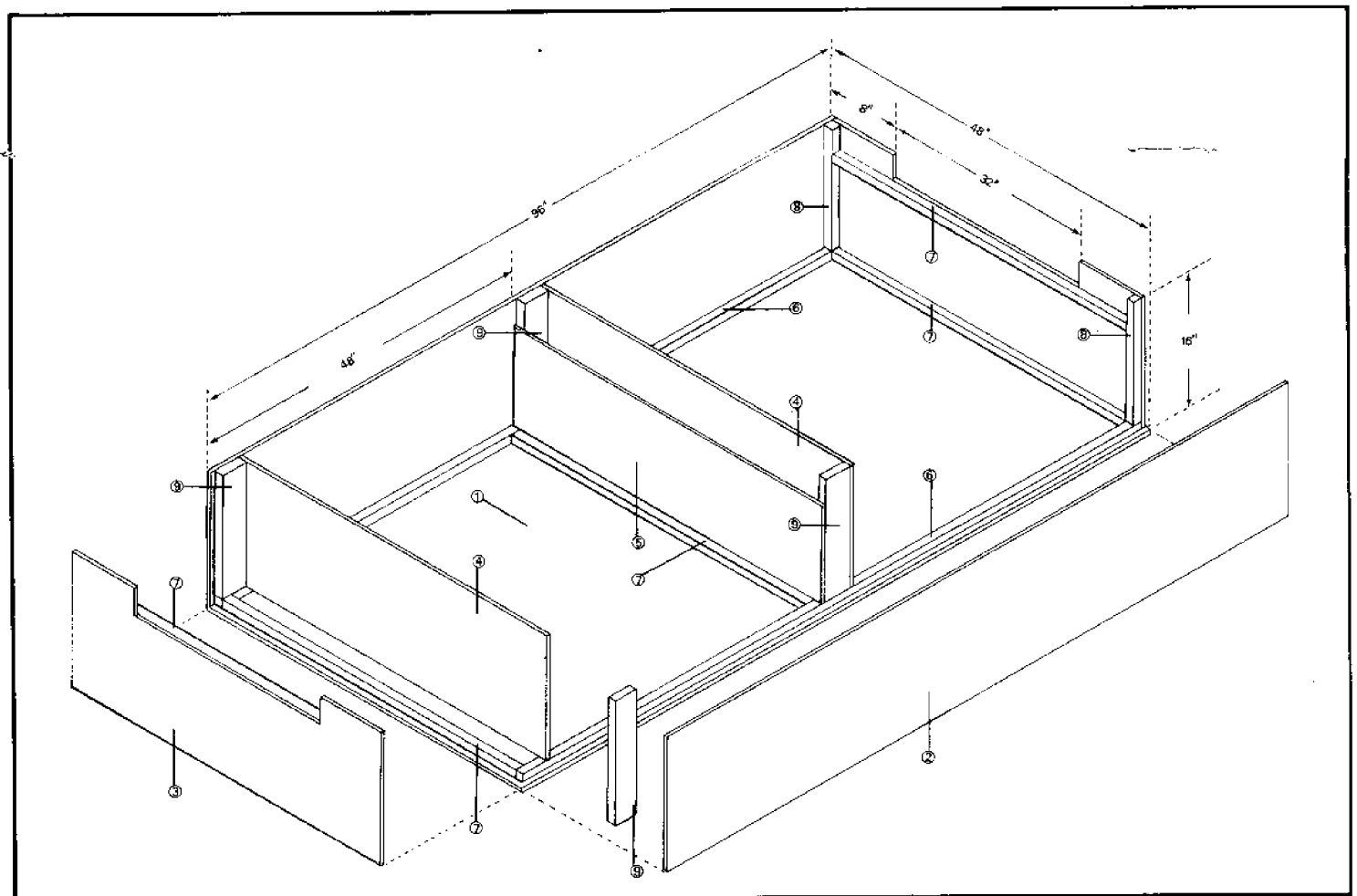

Fig. 6. Construction details of incubator module. Circled numbers refer to parts listed in Table 2. If the incubator module is to be located at the upstream end of a series of modules, the upstream end of the module should be a solid panel without the 3x32-inch cutout. If the incubator module is to be located at the downstream end of a series of modules, the downstream end of the module should be constructed as shown in Fig. 7.

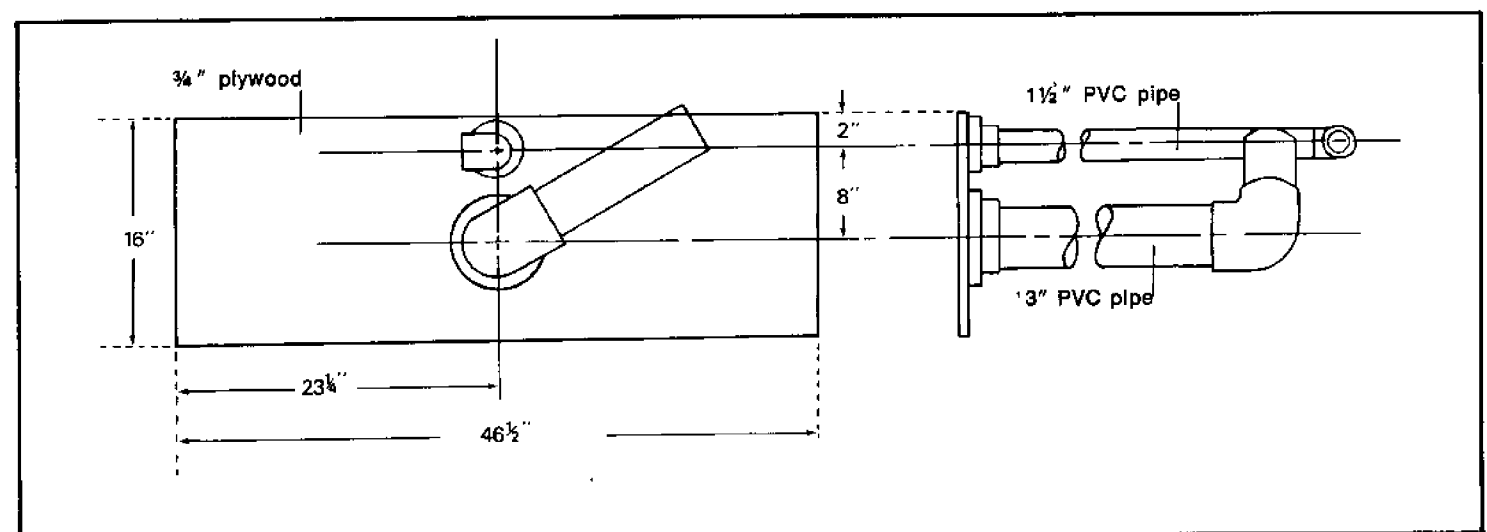

Fig. 7. Alternate end assembly for incubator module. To be used on the downstream end of modules located at the downstream end of a series of modules. See Table 2 for parts list.





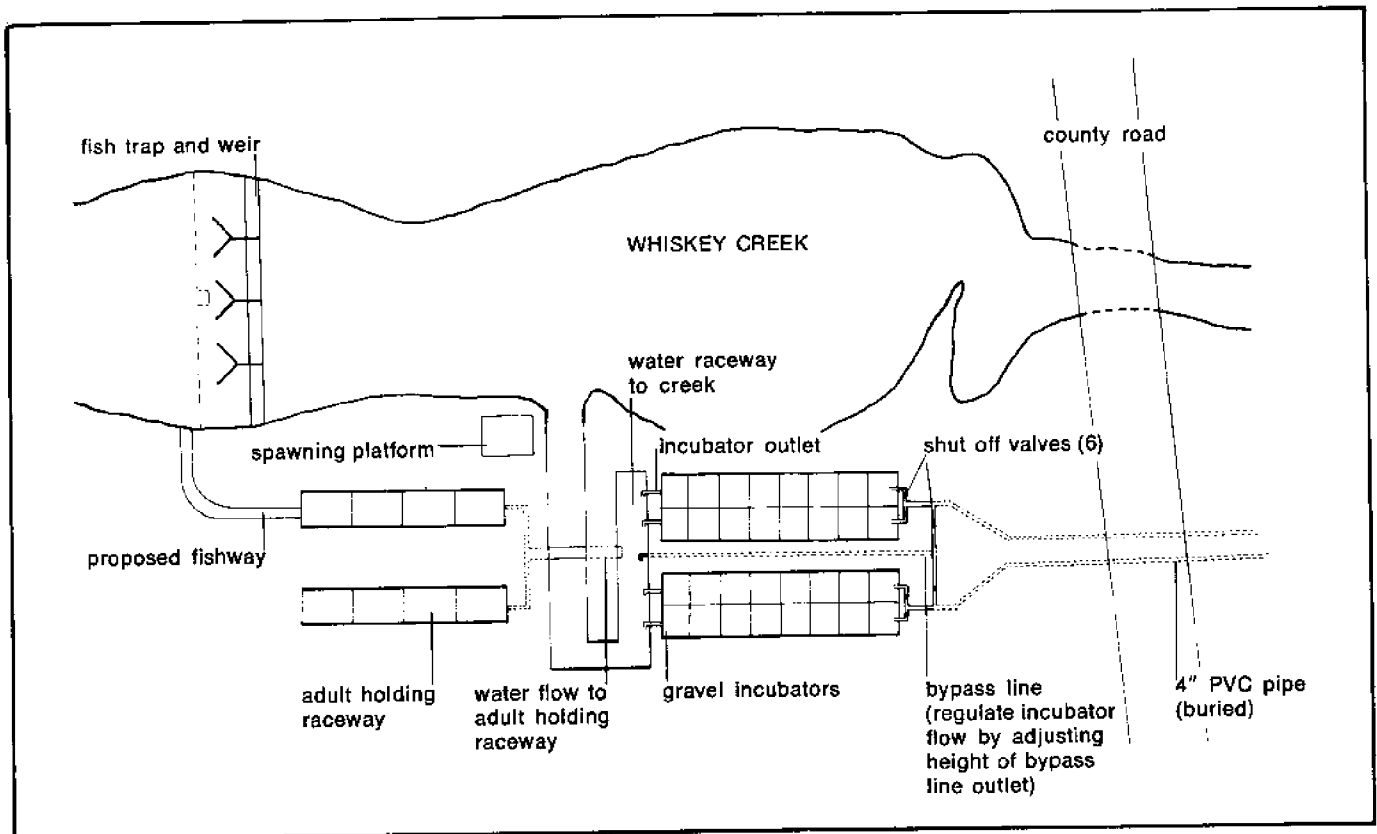

Fig. 8. Overview of hatchery water system from settling pond to fishway.

units. Caulking compound is applied to adjoining surfaces and the modules are secured with  $\frac{3}{8}$  inch (non-galvanized) steel carriage bolts.

### Hatchery Water System

Consistent with development of other systems at the experimental hatchery, emphasis in the development of the hatchery water system has been placed on simplicity, dependability and minimum development cost.

The point of diversion for the water intake system was selected by going upstream to a point where the difference in elevation between the inlet to the streamside incubators and the point of water diversion would provide an adequate hydrostatic head for a gravity flow water system. Water is diverted from the streambed through a 12-inch culvert which was installed through the streambank. A culvert was used in place of an open flume to limit the amount of water which could enter the water intake system during periods of peak stream flow. (See Fig. 9).

The inlet end of the culvert is pro-

tected by a four-foot square grillwork which prevents water-borne debris from entering and possibly fouling the water intake system. The intake grillwork is situated so it can be cleaned easily from the streambank with a garden rake.

Water flows through the intake culvert for about 20 feet and then enters an open canal. The water flows through this canal for a distance of about 250 feet. The canal is fitted with an overflow channel to prevent flooding. From the downstream terminus of the canal, the water flows through 170 feet of 12-inch pipe into a large settling pond. (The contour of the area did not permit extending the canal to the pond, so it was necessary to use pipe at this point.)

The settling pond has a surface area of approximately 5,400 square feet and is an average of five feet deep. This pond serves two purposes. It facilitates the removal of silt and debris from the intake water by settling and provides a positive hydrostatic head for the incubator water system. Since the net inflow of water into the pond

exceeds the net flow of water diverted to the incubators, a constant hydrostatic head is easily maintained by adjusting the level of the overflow from the pond.

Under ideal circumstances, one would establish the dimensions of the settling pond on the basis of the water retention time required to remove the settleable solids from the water system. The more common situation is the case where the size of the pond is dictated by the contour and amount of land available. This was the case encountered in excavating the pond at the Netarts Bay hatchery. Thus, while the pond is an effective regulator of hydrostatic head and precludes water-borne debris from entering the incubator water supply, it is not of sufficient size to remove all settleable solids.

Water is diverted from the settling pond to the gravel incubators through two four-inch PVC pipes. These pipes are buried to reduce expansion and contraction and to prevent inadvertent disruption by personnel working in the hatchery area. Each four-inch line

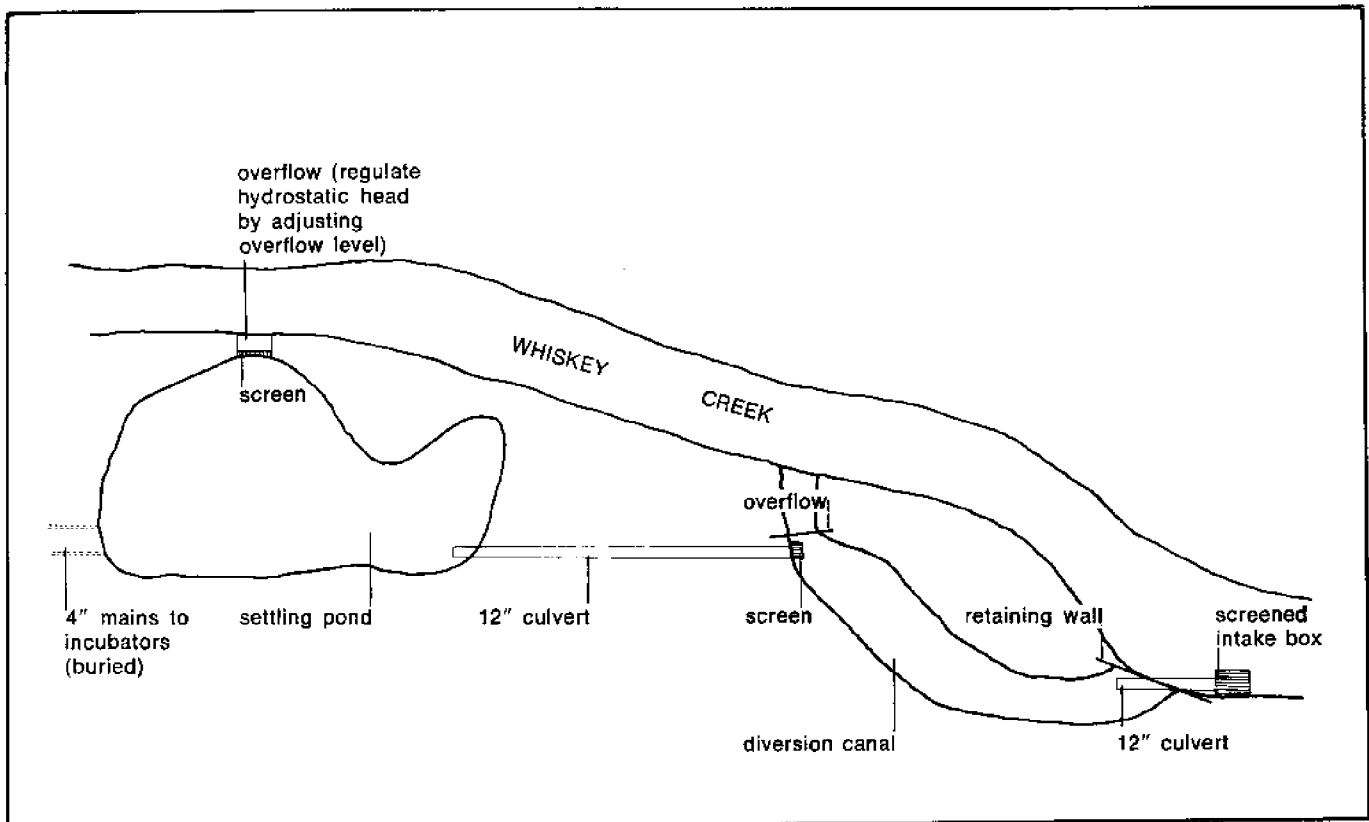

Fig. 9. Overview of hatchery water system from intake culvert to settling pond.

supplies two lines of gravel incubator modules. Either pipe is capable of providing an adequate flow of water to sustain the entire hatchery. The two lines are manifolded so that each line serves as a backup system for the other. Water flow in excess of that needed for the incubators is bypassed into the adult holding facility. (See Fig. 8).

The inlet line to each row of incubators is fitted with a shutoff valve. These valves are operated in either the completely open position or fully closed. They are not used to regulate water flow. A row of four incubator modules receives a flow of 20-30 gallons per minute. Water flow rate through the incubators is regulated by adjusting the bypass flow rate.

Two precautions should be underscored at this point. First, the use of potentially toxic materials such as heavy metals in the water system must be avoided. Specifically, the use of galvanized materials (zinc), brass or bronze (copper), and cadmium should be avoided. Polyvinyl chloride (PVC) and polypropylene pipe and fittings

have been found to be satisfactory materials at the Netarts hatchery. The second precaution is to allow for expansion and contraction of plastic pipe, which has a high coefficient of expansion. Unless the pipe is buried, provisions must be made to allow for expansion to avoid pipe breakage.

#### Adult Holding Facility

Adult chum salmon arrive at the hatchery in varying degrees of sexual maturity. Female fish may be ready for spawning on the day of arrival. Or it may be necessary to hold them for two or three days, perhaps longer, before they are ready to spawn. This is best done in a holding facility out of the streambed. The design of this holding facility may have a profound influence on the ripening of the fish for spawning. The holding facility should have a provision for segregating male and female fish to prevent spawning in the holding facility, and it should have a provision for segregating ripe female fish from those which are green.

The adult holding facilities at the

Netarts hatchery are raceways 20 feet in length, four feet wide and three feet deep, with gravel bottoms. Each raceway receives a water inflow of approximately 100 gallons per minute. The water is introduced near the bottom to prevent stratification and insure mixing.

Screen partitions divide the raceways into four compartments. These raceways will hold approximately 200 mature chum salmon each. A decreased loading is used in each compartment. When holding the maximum number of fish, the compartments hold 80, 60, 40 and 20 fish, respectively, starting at the upstream end. The raceways are fitted with plywood covers to prevent fish escaping when the hatchery area is unattended. If a raceway is used to hold fish of both sexes, males are always held in compartments downstream of those holding females. The raceways are illustrated in Fig. 10.

#### Trapping Facilities

The ocean ranching trap serves a dual purpose. In addition to the usual

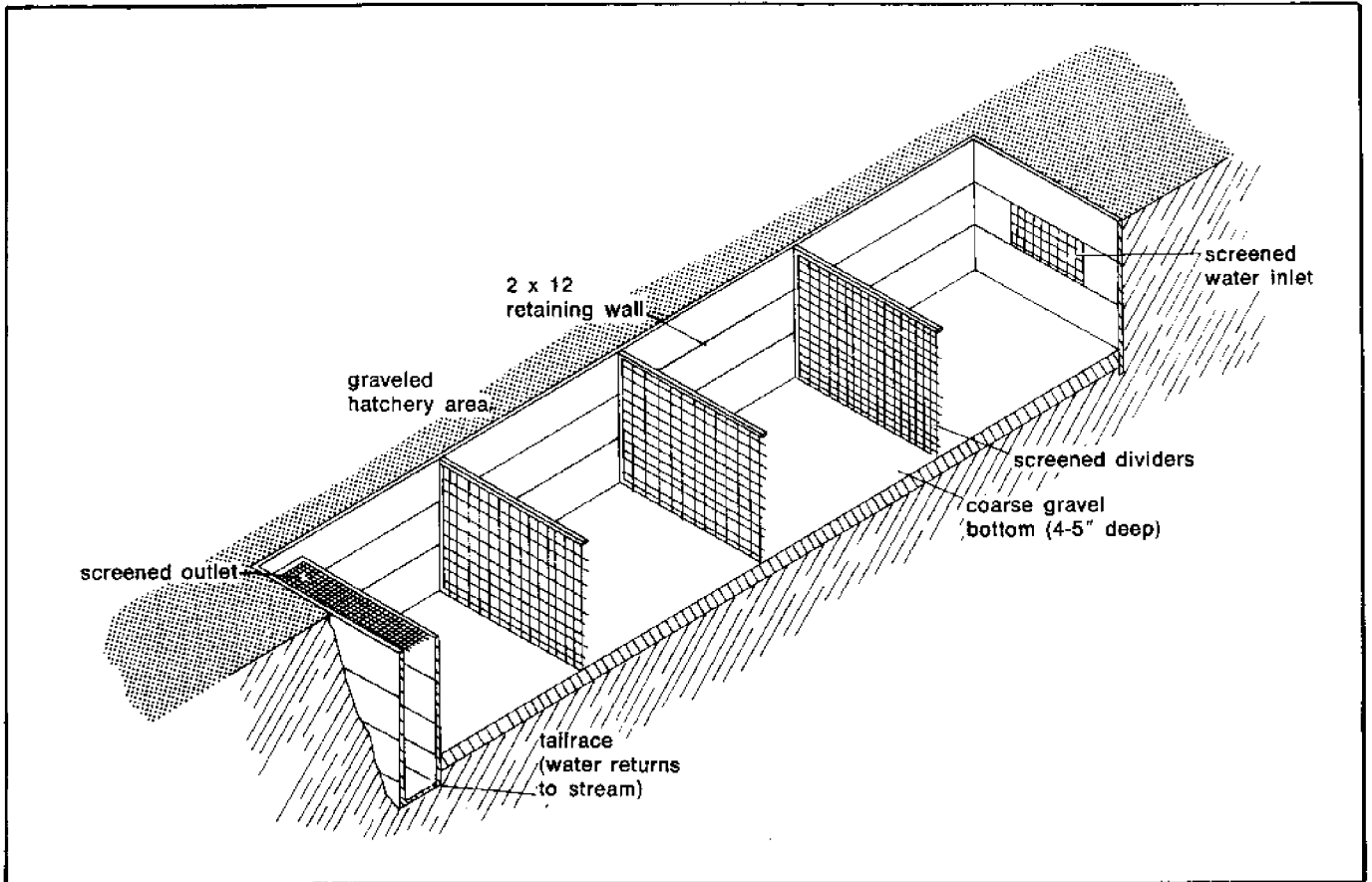

Fig. 10. Adult holding raceway. Raceway is 20 feet long, 4 feet wide and 3 feet deep.

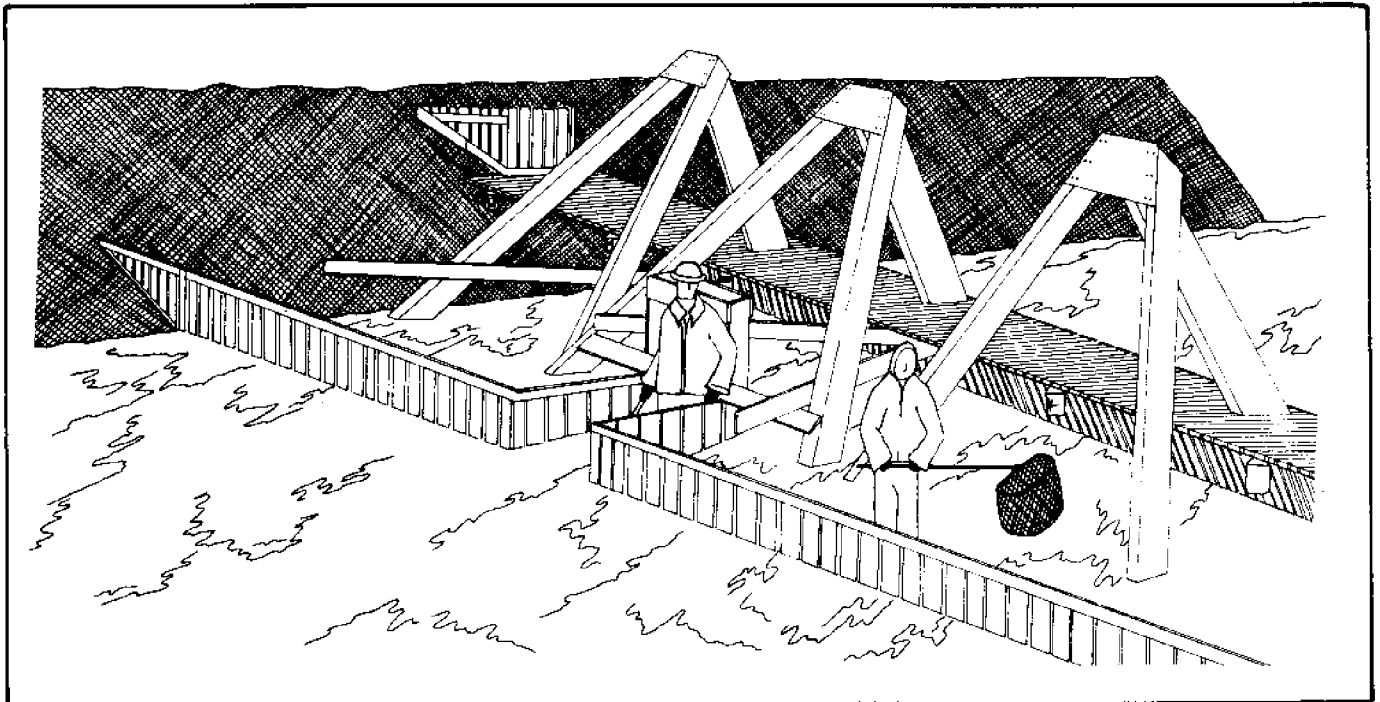

Fig. 11. Netarts Bay weir and fish trap.

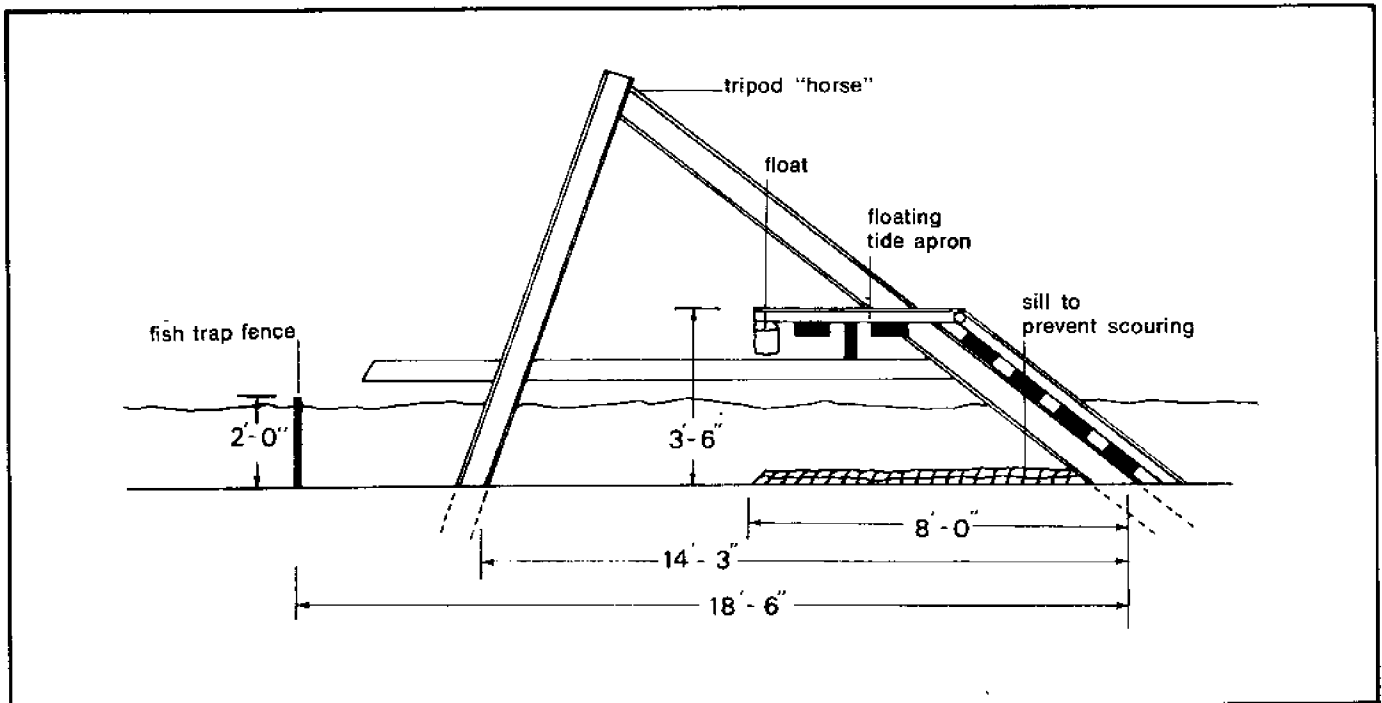
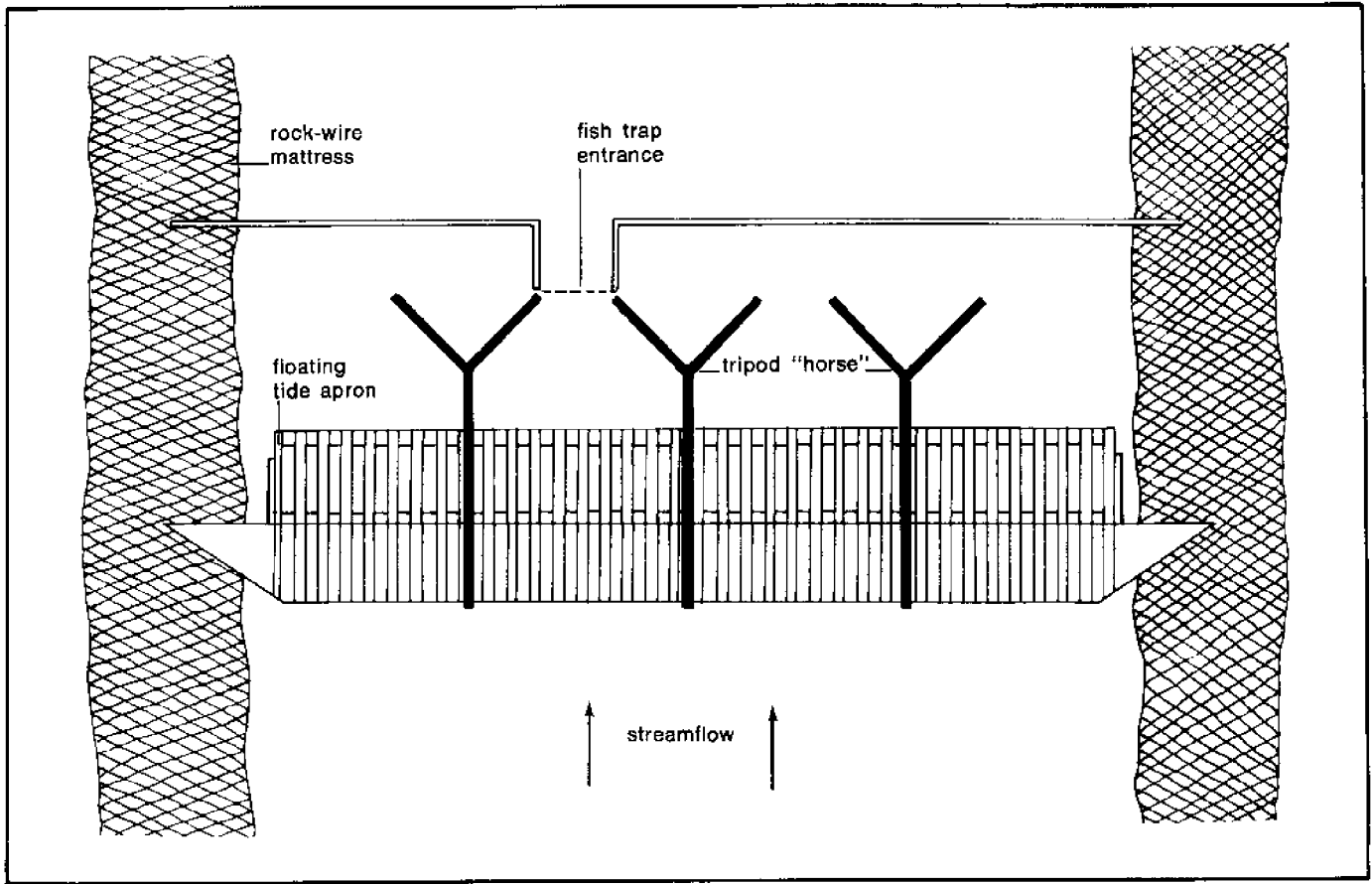

Fig. 12. Schematic diagram of weir.

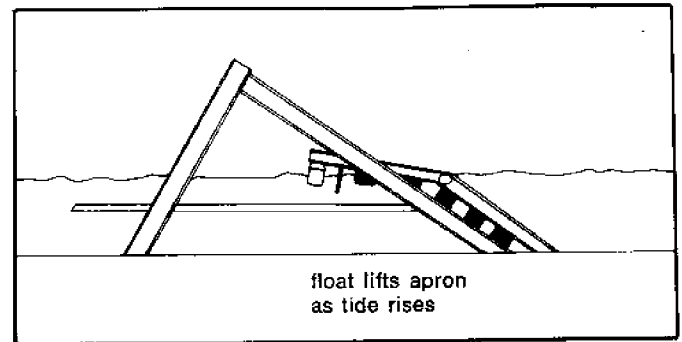
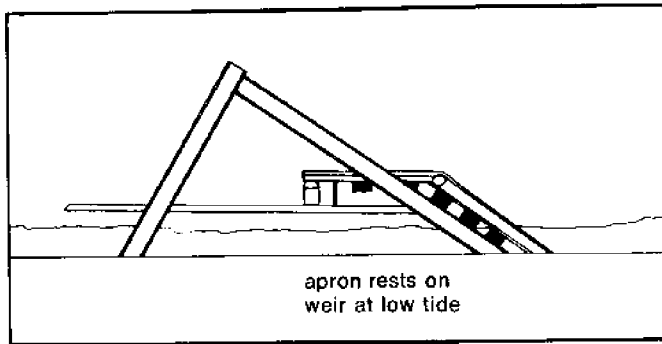

Fig. 13. Operation of the weir apron.

hatchery function, i.e., the trapping of mature fish for spawning, it is also used to harvest the crop for market.

A trap for ocean ranching presents a number of design problems because the weir may be installed in the tide-water region of a coastal stream and because of the nature of coastal streams which are exploited for ocean ranching. These streams typically undergo rapid severe fluctuations of streamflow during periods of rain. They are prone to carrying heavy loads of debris which are potentially capable of obstructing the passage of water through the weir. The stability of the streambank is typically poor; excessive erosion is frequently observed. If a weir is constructed of sufficient height to prevent the upstream migration of fish during the highest tides, flooding of the adjacent area is certain to result during periods of peak streamflow. The minimum design criteria to be considered in constructing a weir for ocean ranching:

1. The weir must be sufficiently strong to withstand maximum streamflow, even when totally fouled with debris.
2. The weir must prevent the upstream migration of adult fish under all conditions of tide.
3. The stream configuration in the vicinity of the weir must allow the passage of maximum flow over the weir without flooding adjacent areas, and the streambank must resist erosion and scouring under and around the weir.
4. The design of the weir must be consistent with all legal considerations relating to the placement of structures in navigable waters.

5. The cost associated with installing, maintaining and operating the weir must be within the reach of private commercial hatcheries. In addition, in many instances the design of the weir must lend itself to installation in remote sites.

The weir at the Netarts Bay hatchery satisfies all these requirements.

Dr. Royal H. Brooks, Oregon State University Department of Agricultural Engineering, cooperated in developing the weir. He estimated the maximum streamflow that would be encountered at the trapping site and recommended a stream cross section configuration and weir height that would handle that flow. The streambank was then graded to the recommended configuration and stabilized by the installation of a rock-wire mattress before the weir was constructed. An overall view of the Netarts weir is shown in Fig. 11.

The Netarts Bay weir is supported by three "horses," steel tripod structures. The horses are asymmetrical. The upstream leg is 14 feet long; the downstream legs are approximately 9 feet long. The horses are secured in the streambed by their own weight. Horses constructed of timbers also have been used successfully in construction of fish weirs. When wooden horses are used, a box-like structure is assembled between the legs of the horse above the water line and weighted with rocks or other high density material. A schematic diagram of the weir is shown in Fig. 12.

The horses support two horizontal 4 x 4 beams which extend the full width of the streambed and are an-

chored to the streambank on each side. These horizontal beams support the vertical grillwork comprised of 2 x 2 dimensional lumber spaced 1½ inches apart. The grillwork is assembled in removable panels which are placed on the weir before the first fish are expected to arrive, and left in place until the spawning migration is over. They are then removed and stored for the remainder of the year. In this way, the stream is only restricted during the time of trapping operations.

Scouring under the weir is prevented by a sill which is attached to the lower horizontal support and extends into the stream bottom to a depth of about two feet. Heavy Vexar® netting was used for this purpose on the weir at Netarts Bay. A rigid wooden sill probably would function equally well.

The weir described to this point satisfies all the design criteria except for the requirement to prevent the passage of fish upstream during periods when the height of the tide exceeds the height of the weir. This requirement was satisfied by fitting a hinged horizontal apron to the weir. The length of the horizontal apron is slightly greater than the distance between the top of the weir and the water level at the highest tides encountered. The upstream end of the apron is hinged to the upper horizontal beam of the weir. The downstream end of the apron is fitted with buoyant devices. When the level of the tide exceeds the height of the weir, the downstream end of the horizontal apron floats up and presents a barrier to the upstream migration of fish. The operation of the apron is shown in Fig. 13.

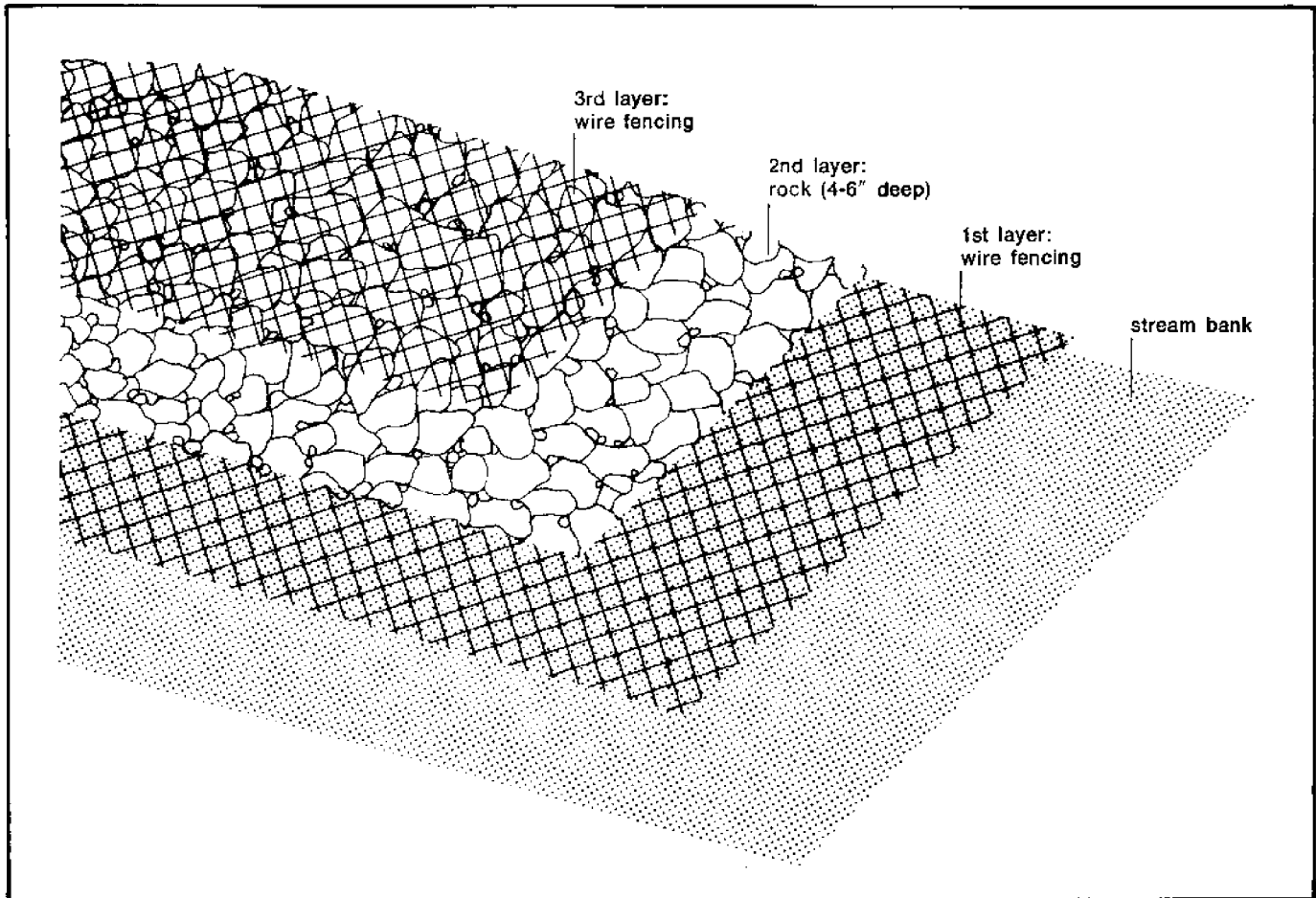

Fig. 14. Construction of the rock-wire mattress used to prevent stream bank erosion.

The streambank in the vicinity of the weir is protected against erosion by a rock-wire mattress. This is a form of rip-rap which is well suited for this type of installation. The mattress consists of a layer of rock four to six inches deep which is secured on top and bottom by chain-link fencing. The mattress is illustrated in Fig. 14.

The remainder of the trapping facility at the Netarts Bay hatchery has not been completed, so the following describes an aspect of the hatchery which has not been production tested. The purpose of the final installation is to move fish from the weir to the holding facility. In previous years, this has been accomplished manually, and thus has been a labor intense operation, inconsistent with the philosophy of ocean ranching. The proposed alternative, to be completed prior to the 1975 season, is a fishway which will allow the mature salmon to move directly

from the weir into the adult holding facility.

The proposed fishway is a raceway extending from the adult holding facility to the streambed immediately below the weir (see Fig. 9). The fishway will also serve as the water discharge channel for the holding facility. The bottom elevation at the upstream end is equal to that of the holding raceways and drops in gradual steps to streambed elevation at the outlet. The water passage between steps is below the surface of the water to encourage the upstream movement of chum salmon.

### Spawning Area

Consideration should be given to the layout of the spawning area at the time the hatchery facility is designed. The spawning area should be laid out in such a way as to maximize the efficiency of spawning operations. Provi-

sions for maintaining cleanliness during spawning operations should be incorporated. Cleanliness minimizes egg losses and the introduction of contaminants and disease organisms into the incubators. Further, it is essential to maintain high standards of cleanliness if the carcasses are to be marketed after spawning.

The spawning platform at the Netarts hatchery is illustrated in Figs. 15 and 16. This platform serves a small pilot hatchery. Thus, while the illustrated design is functional, it might need to be enlarged for use in a commercial operation. A further improvement would be to cover it; however, this is not a necessity.

The spawning area is adjacent to both the adult holding facility and the streamside incubators. The location provides access to the brood stock and facilitates the orderly movement of eggs to the incubators.

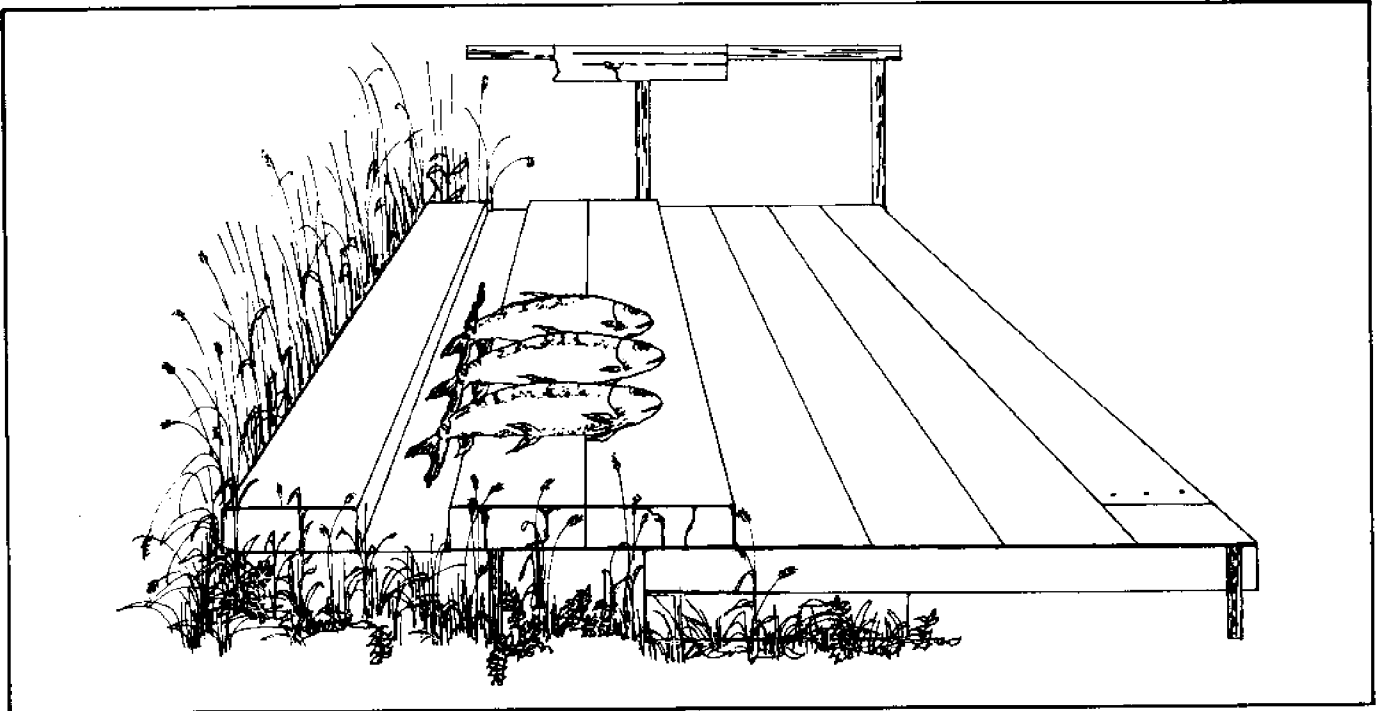

Fig. 15. Spawning platform used at the Netarts Bay Hatchery.

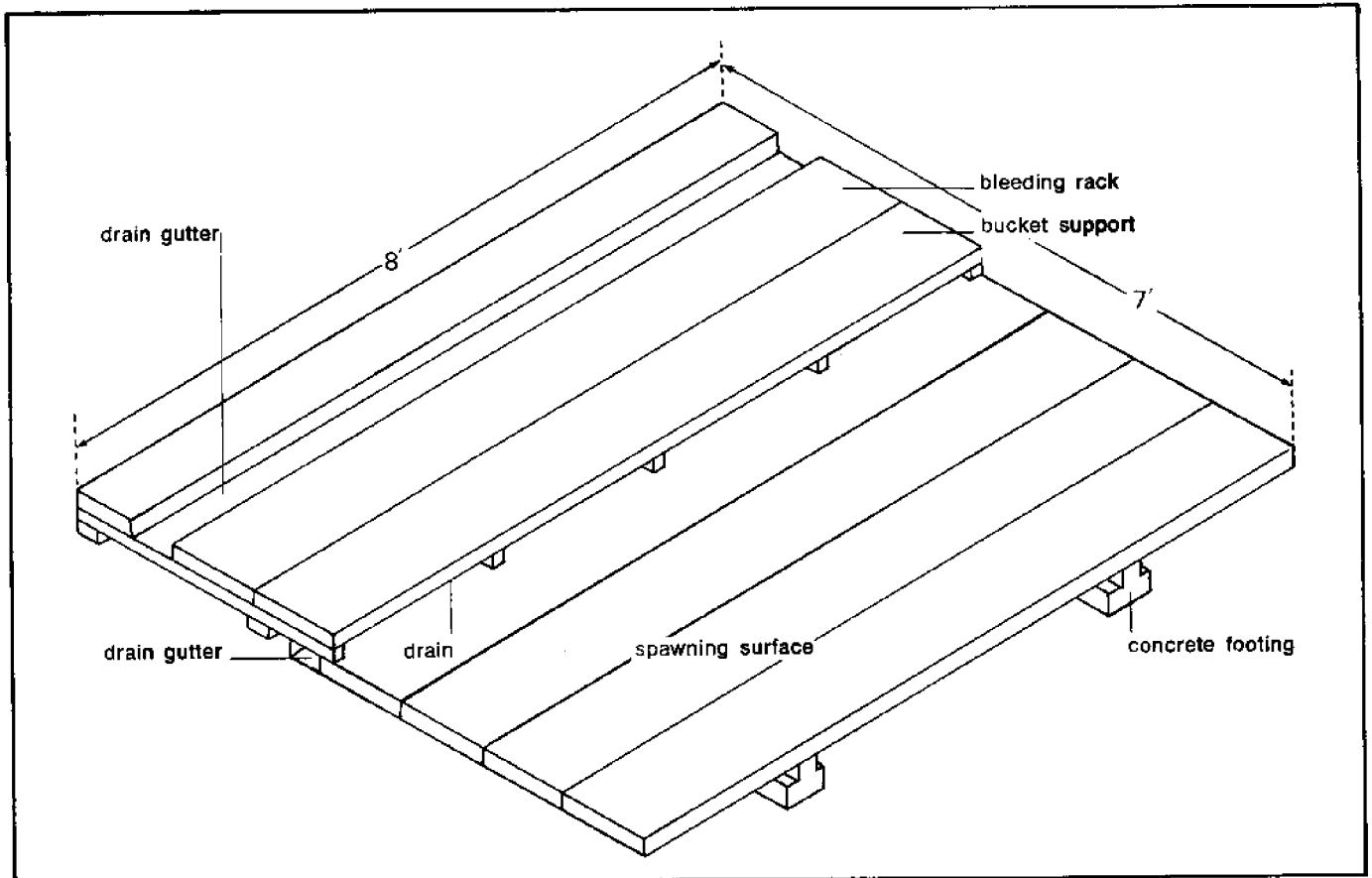

Fig. 16. Construction of spawning platform.

# the hatchery routine

---

Salmon propagation involves both science and art. Because of the element of art, one often encounters a diversity of opinion regarding methodology. In many instances, the decision as to what constitutes the *best* method is left to the discretion of the fish culturist. The best method is often the method with which one associates the greatest degree of confidence.

The methods outlined in this section have been satisfactorily employed at the Netarts Bay hatchery. They are generally typical of the methods employed at most salmon hatcheries today. Where appropriate, they have been modified to suit the species and the production system. They are described here primarily for the benefit of the novice fish culturist. The intent is to impart some feeling for the hatchery routine and how it relates to the physical facilities described in an earlier section.

## Trapping and Sorting

The spawning process commences with the trapping of mature fish. Mature salmon are removed from the trap several times each day. Fish to be used for propagation are transferred to the adult holding facility. Surplus fish are slaughtered at once.

Female fish are spawned as soon after they have become ripe (i.e., fully mature) as possible. Timing is important at this point. Reduced viability of eggs will result if females are spawned while they are green (i.e., not fully ripe) or if they are overly ripe. The spawning condition of each female fish in the adult holding facility is tested at least once each day. Ripe fish are segregated from green fish and are spawned as soon as possible.

Determining the relative ripeness of mature chum salmon is an art acquired through experience. At the Netarts Bay hatchery, we rely mainly on feel rather than on sight in judging the degree of sexual maturity. The visual indicators of maturity that are useful in sorting other species of Pa-

cific salmon seem to be less reliable as indicators of ripeness of chum salmon. It has been our experience that the characteristic feel of the forward portion of the abdomen of a ripe fish is the most dependable indicator of ripeness.

To determine the degree of maturity a female fish is grasped by the tail and held firmly with her head slightly lower than her tail until she relaxes completely (see Fig. 17). (A pair of cotton or nylon gloves improves one's grip.) The forward portion of the abdomen is gently pressed. With experience, one learns to recognize a characteristic feeling associated with the degree of ripeness. A loosening of the eggs within the ovaries occurs during the process of maturation. It is this feeling of the ovary in the forward extremity of the abdominal cavity which is used as an indicator of sexual maturity.

Many fish will be observed to pass eggs freely through the vent when they are handled, and one may be tempted to use the ejection of eggs as a criterion for judging ripeness. There are two reasons why this is a dangerous practice. First, the process of releasing eggs from the skeins as maturity proceeds occurs from the rear of the ovary forward. Therefore, a partially ripe fish (in which the eggs are still tightly bound at the forward end of the ovary) may pass eggs freely from the rear of the ovary. Second, one may encounter fish which, although completely ripe, are incapable of passing eggs through the vent. These fish likely would be held until overripe. In both cases, a decrease of fertility probably will result.



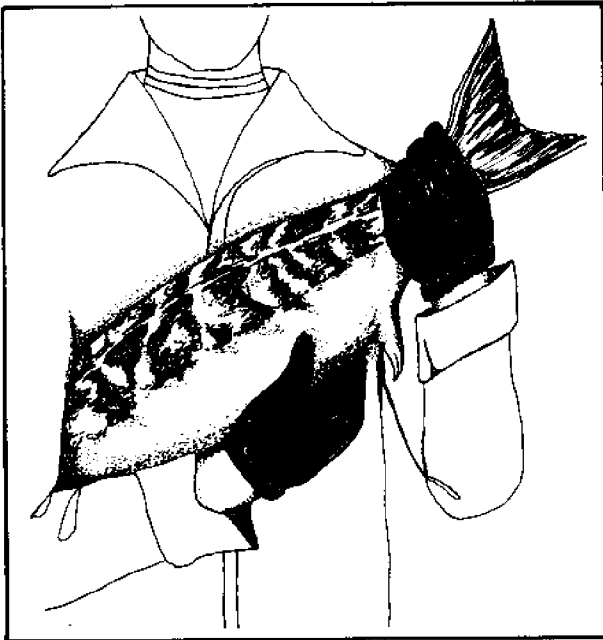

Fig. 17. Testing female salmon for ripeness.

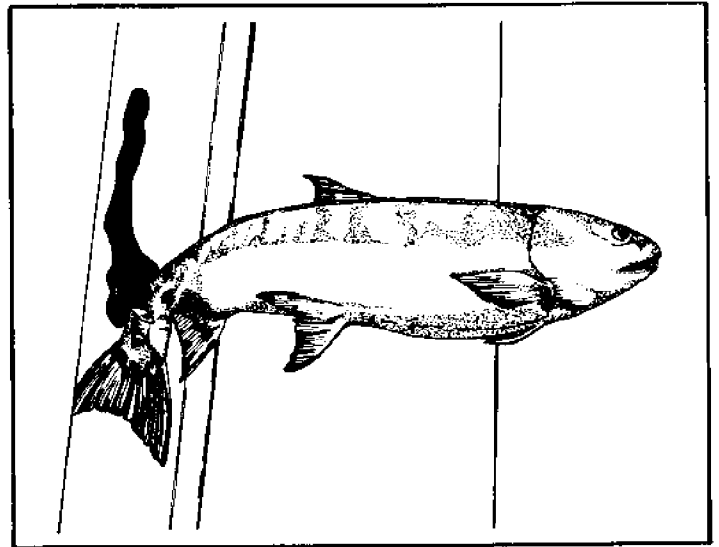

Fig. 18. Incision for bleeding female fish on spawning platform before taking eggs.

## Spawning

At the Netarts Bay hatchery, female fish are killed by a sharp blow on the head before spawning. The fish are placed on the bleeding rack portion of the spawning platform with their tails extending over the drain gutter (see Fig. 18). An incision is made into an artery near the tail region. The location of this incision is shown in Fig. 18. The fish are allowed to bleed for five minutes or more. During this period, male fish are taken from the holding facility, killed in the same manner as the female fish, washed with fresh water, and placed on the spawning platform. Male fish are not bled.

The incision method is used for taking eggs at the Netarts hatchery. A washed, well drained plastic bucket of approximately 8 to 10-quart capacity is placed on the spawning platform against the bucket support surface. The bucket is held in place between one's feet. The female fish is grasped by inserting fingers in the gill cavity. The point of the spawning knife is placed in the vent before lifting the fish. This prevents losing eggs while the fish is being moved from the bleeding rack to the bucket. The fish is moved around the bucket and into a vertical position so the vent is about

one-half inch to one inch above the lip of the bucket. The fish can be held securely in this position by bracing the back of the fish between one's knees (Fig. 19). An incision is made by raising the knife to a point just below the pelvic fin, then out around the pelvic fin, back to the center line and continuing upward to a point just under the hand supporting the head of the fish. If the fish is ripe, most of the eggs will flow freely into the bucket. The remaining eggs can be dislodged by placing one's fingers in the abdominal cavity and gently shaking the viscera. If the fish is not ripe, gentle shaking will not dislodge the eggs. In this case, the female should be discarded. Green eggs, i.e., those which must be removed by force, should not be placed in the incubators as a large proportion of infertile eggs are probably included.

The spawning incision is best made with a knife which is capable of cutting with a drawing motion. Linoleum knives have been used for this purpose. Some hatcherymen prefer spawning knives of their own designs. At the Netarts Bay hatchery, a commercially available knife is used which was developed for the purpose of opening the visceral cavity of fish and game. The Zak knife, available from

the Zak Tackle Manufacturing Company, 235 South 59th Street, Tacoma, Washington, 98408, is an extremely useful tool in the spawning process.

At the Netarts Bay hatchery, milt is passed directly from the male fish into the spawning bucket. The male fish is grasped in much the same way as the female fish was held during testing for ripeness, only with the head elevated slightly above the tail. The fish is held slightly to one side of the spawning bucket with the vent directed away from the bucket. Starting with one hand under the abdomen of the fish just behind the pectoral fin, the hand is moved slowly along the abdomen, applying just enough pressure to maintain an even stream of milt. The first milt ejected is likely to be watery; this should not be placed in the egg bucket. When a steady stream of dense milt is observed, a small quantity of this, about a half teaspoon or so, is directed into the egg bucket (Fig. 20). When the desired amount has been introduced into the egg bucket, release the pressure to discontinue the flow.

Cleanliness is very important during the egg-taking process. Blood and slime in the eggs may interfere with fertilization and provide nutrients for disease organisms if carried over into

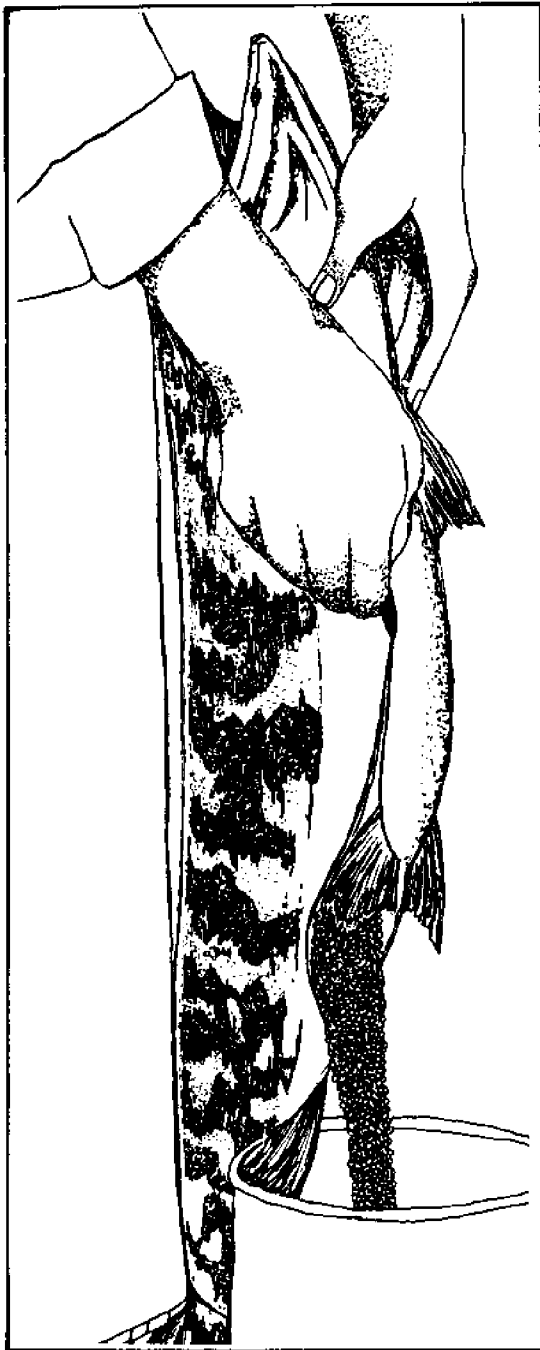

Fig. 19. Making incision to collect eggs from female.

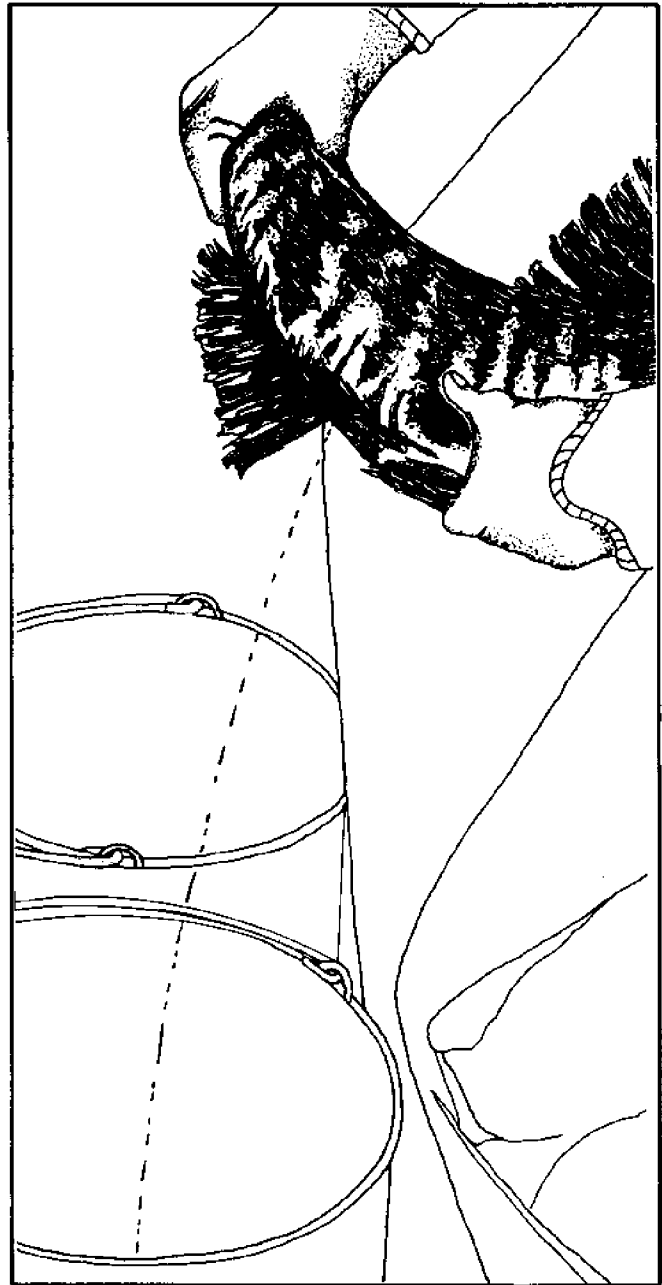

Fig. 20. Stripping milt from male salmon into a bucket containing eggs.

the incubators. Care is taken to avoid holding the fish over the bucket while maneuvering it into position. The bleeding incision is held below the level of the top of the bucket at all times.

At the Netarts Bay hatchery, each female is fertilized with at least three

males. This serves two purposes. First, it virtually assures that viable sperm will be introduced into each bucket. Second, it increases the number of matings accomplished and helps to maintain the genetic variability in the breeding population. Milt from each of the three males is introduced into

a different side of the bucket and is then mixed with the eggs by stirring the eggs gently with one hand.

The bucket containing fertilized eggs is then taken directly to the streamside incubator. The egg trays are secured in their submerged position before placing the eggs on the

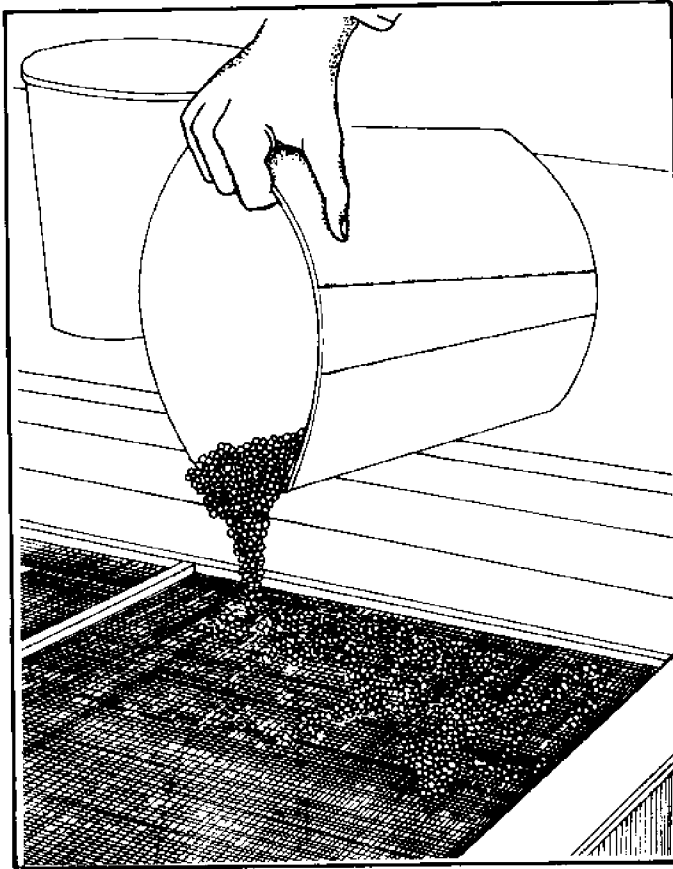

Fig. 21. Distributing fertilized eggs on incubator screen trays.

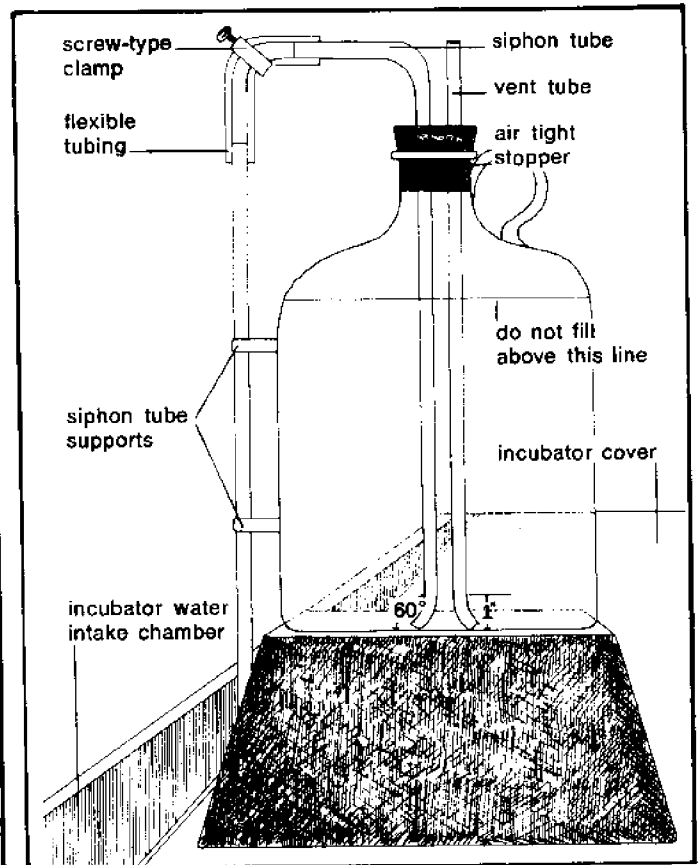

Fig. 22. Construction of drip bottle used in Malachite Green treatment.

trays. The eggs are then distributed carefully on the surface of the water and allowed to settle on the trays. See Fig. 21. Each tray is comprised of four compartments. Eggs from one female only are placed in each compartment. This simplifies the removal of non-viable eggs from the incubator. After eggs from four females have been added to a tray, the next tray is placed in the incubation cell and secured in its submerged position. This process continues until each cell contains four trays.

Female fish in which one skein has released the eggs while the eggs remain tightly bound in the other ovary are occasionally encountered. This is thought to be a heritable deformity. All eggs from fish displaying this malformation should be discarded.

### Incubation

Incubation of eggs at the Netarts hatchery is largely a hands-off operation. During the first four to six weeks

following fertilization, the eggs are extremely sensitive to mechanical shock and should not be disturbed for any reason. After this period, the eggs may be handled without detrimental effect. The end of the sensitive period is accompanied by the appearance of a dark pigment spot on the egg. Eggs which have developed this spot are said to be "eyed."

During the eyed stage, dead eggs may be removed from the incubators if desired. Removal of dead eggs is desirable for fungus control but is a tedious, time consuming and costly task. In previous years, dead eggs were removed from the incubators at the Netarts Bay hatchery as part of the fungus control effort. We now use a compromise fungus control measure, removing only large clusters of dead eggs. The remaining dead eggs are left in the incubators through the incubation cycle and fungus growth is controlled by chemical treatment with Malachite Green.

### Fungus Control

Malachite Green is administered by the drip bottle method three or four times weekly. This method involves injecting a solution of fungicide into the incubator inlet in proportion to the water flow into the incubator, resulting in an effective fungicide concentration of one to two parts per million in the incubator. Fungicide injection is continued for one hour during each treatment. To maintain a constant fungicide concentration in the incubator, both the incubator water flow and the fungicide flow must remain constant. Incubator water flow normally remains relatively constant. Injection of the fungicide at a constant rate is readily accomplished by using a constant flow siphon bottle or "drip bottle."

A constant flow siphon bottle is easily constructed from an ordinary one-gallon jug. The jug is fitted with an air-tight stopper through which passes a siphon tube and a vent tube.

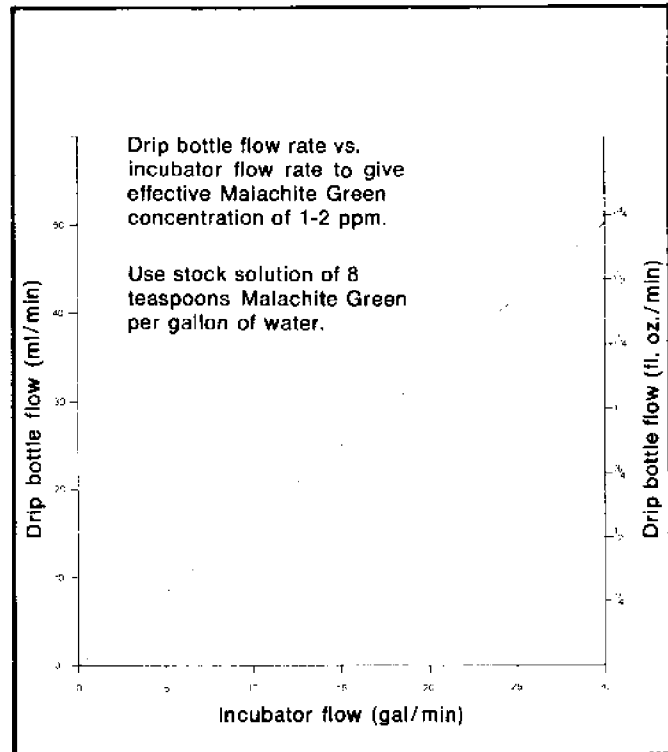

Fig. 23. Incubator flow rate vs. drip bottle flow rate for Malachite Green treatment. To use the graph, locate the incubator flow rate on the horizontal axis, find the corresponding point on the diagonal graph, then locate the drip bottle flow rate on the vertical axis beside that point on the graph.

The siphon tube extends nearly to the bottom of the bottle on the inside and below the bottom of the bottle on the outlet end. The vent tube extends to about the same depth in the bottle as does the siphon tube but is open at the top of the bottle. When the bottle is siphoning, it will deliver liquid at a constant rate until such time as the liquid level reaches the bottom of the vent tube. The rate at which siphon bottles deliver can be regulated in one of two ways: one can regulate the distance between the bottom of the vent tube and the siphon tube outlet, or alternately, can place a piece of flexible tubing fitted with a screw type clamp on the siphon tube outlet. Construction of the drip bottle is shown in Fig. 22.

Materials needed for the Malachite Green treatment include the drip bottle as described, Malachite Green crystals, a measuring teaspoon, a one-quart liquid measure, a bucket of approximately five-gallon capacity grad-

uated in one-quart intervals, and a watch with a sweep second hand.

The procedure used for the Malachite Green treatment at the Netarts Bay hatchery is as follows: (1) determine the water flow rate through the incubators by collecting water from the outlet pipe in the calibrated bucket for a known period of time and then calculate the total flow in gallons per minute; (2) make a stock solution of Malachite Green containing 8 level teaspoons of Malachite Green per gallon of water and place this solution in the drip bottle; (3) determine the desired drip bottle flow rate from Fig. 23 by locating the incubator flow rate on the vertical axis, finding the corresponding point on the diagonal graph, and then locating the drip bottle flow rate which corresponds to this incubator flow rate on the horizontal axis; (4) start the siphon and adjust the drip bottle flow to the desired rate; and (5) direct the drip bottle flow into the inlet chamber

of the incubator and allow the flow to continue for a period of one hour.

Malachite Green treatment can commence on the day after fertilized eggs are placed in the incubators and continue through the entire incubation period up to hatching. Discontinue the Malachite Green treatment before the first hatching occurs.

At the date of this writing, the use of Malachite Green in fish culture applications had not received Food and Drug Administration approval. Fish culturists are advised to determine the legal status of any drugs or chemicals before using.

### Hatching and Release

Under the climatic conditions encountered at the Netarts hatchery, hatching occurs from 8 to 10 weeks after fertilization. When hatching is complete, the egg support trays are removed from the incubators, cleaned thoroughly and placed in storage. The incubators remain covered after hatch-

ing so that the alevins are maintained in total darkness until utilization of the yolk material is complete. At the Netarts hatchery, this has been 14 to 16 weeks after fertilization.

Fry are allowed to migrate out of the hatchery when they are capable. Access to Whiskey Creek is via the incubator outlet pipes which empty into a common raceway. This raceway drops from hatchery elevation to stream elevation in a series of gradual steps. Out-migration is usually encouraged by removing the covers from the incubators. There are always a few stragglers who refuse to leave the incubators. These must be removed manually and released into the stream. When the out-migration is complete, the incubator water flow is terminated, the gravel is removed and washed, and the incubators are cleaned and repaired to prepare them for the subsequent season.

### **Shipping Eggs to Private Hatcheries**

It has been previously noted that one of the objectives of the Netarts Bay project has been to develop an egg source from which private hatcheries could obtain eggs to be used to establish their own stocks. The Oregon Department of Fish and Wildlife has distributed a significant number of surplus eggs from the Whiskey Creek stock to private hatcheries.

Ripe male and female fish are prepared for spawning as outlined in the previous sections. Eggs are harvested from the female fish as described and placed in plastic bags. The plastic bags are sealed and placed on a bed of crushed ice in an ice chest. Using the methods described, milt is collected in separate plastic bags. Milt from several fish may be placed in a single bag. The bag is tightly sealed and buried in the layer of crushed ice in the ice chest. The eggs and sperm are then transported in the ice chest to the hatchery site where they are to be incubated. The bags containing the eggs are opened and the eggs are

placed in plastic buckets. Several drops of milt are added, and the eggs and the milt are gently mixed. The eggs are then ready to be placed in the incubators.

This method has yielded excellent results. Fertilization success at private hatcheries receiving eggs from Netarts Bay and transported by this method has been comparable to fertilization success realized at the Netarts hatchery, and is significantly better than the fertilization success observed when the eggs are fertilized prior to shipment.

### **For More Information**

For more detailed information on hatchery methods, see textbooks dealing with the subject. Noteworthy in this respect are four inexpensive publications which should be part of every hatchery library:

Bakkala, Richard G. Synopsis of biological data on the chum salmon, *Oncorhynchus keta*. (Walbaum) 1792. (Order from the Northwest Fisheries Center, 2725 Montlake Blvd. E., Seattle, Washington 98112. Free.)

Leitritz, Earl. Trout and salmon culture. Fish Bulletin No. 107, California Department of Fish and Game. (Order from the Office of Procurement, Documents Section, P.O. Box 20191, Sacramento, California 95820. Price \$2)

McNeil, W. J. and J. E. Bailey. Salmon ranchers manual. (Order from Northwest Fisheries Center, Auke Bay Laboratory, P. O. Box 155, Auke Bay, Alaska 99821. Free.)

Wood, James W. Diseases of Pacific salmon: their prevention and treatment. (Order from Washington Department of Fisheries, 115 General Administration Building, Olympia, Washington 98501. Price \$5)

