

LOAN COPY ONLY

MSG-E-97-11

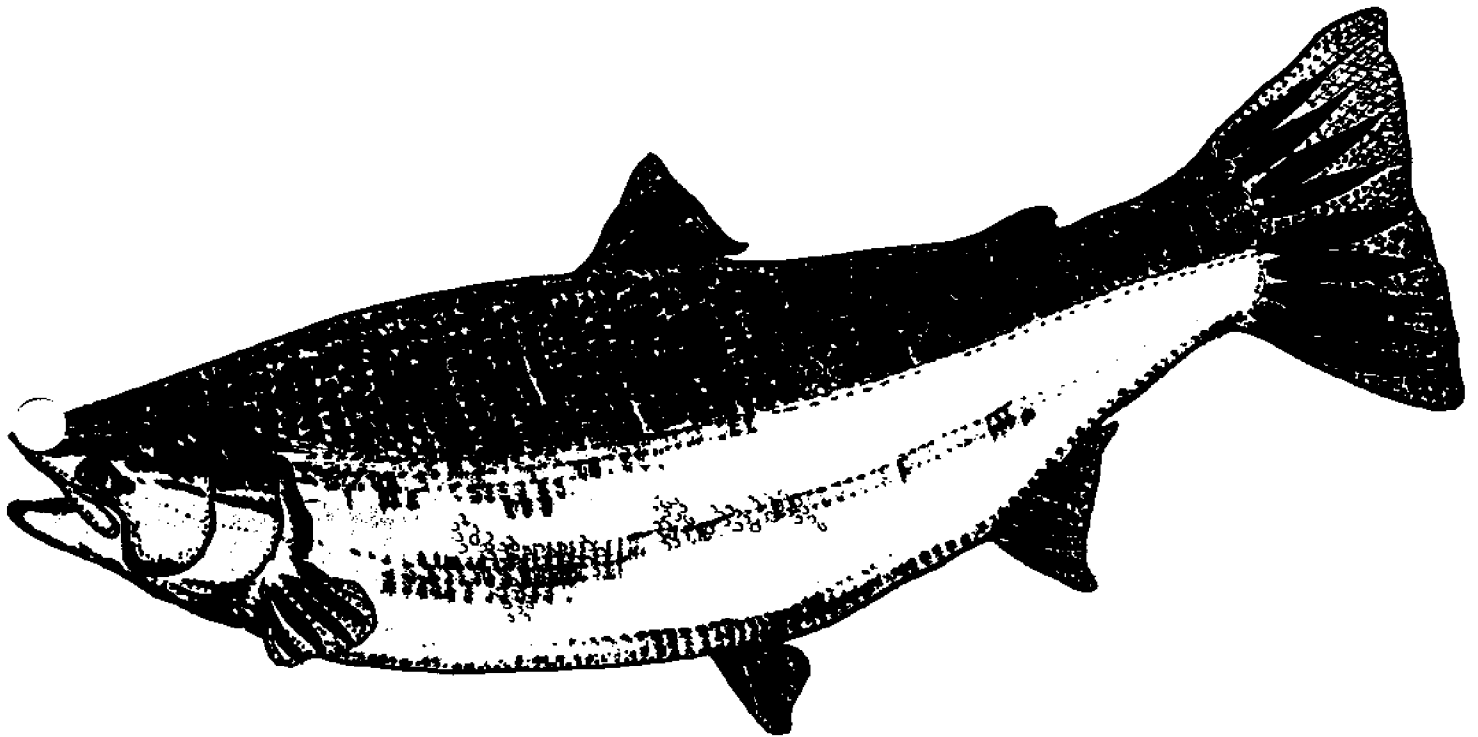

Aquaculture in Maine

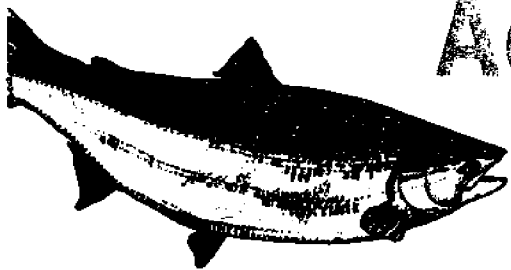

A curriculum guide for secondary school teachers

NATIONAL SEA GRANT LIBRARY
Pell Library Bldg. GSO
University of Rhode Island
Narragansett, RI 02882-1197 USA

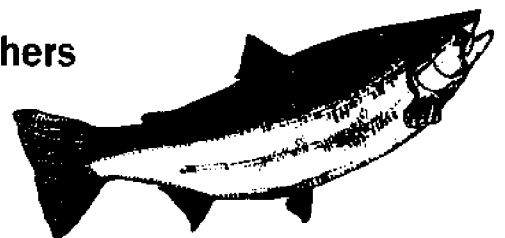

AQUACULTURE IN MAINE

A Curriculum Guide for Secondary School Teachers

TABLE OF CONTENTS

- 1 Introduction to Aquaculture 5**
ACTIVITY: AQUACULTURE AND THE GLOBAL COMMONS
- 2 Aquaculture Around the World 13**
ACTIVITY: AQUACULTURE TIME LINE
ACTIVITY: GLOBAL GRAPHING
- 3 Aquaculture in Maine 25**
ACTIVITY: MAPPING MAINE'S AQUACULTURE SITES
ACTIVITY: AQUACULTURE NEWSLETTER
ACTIVITY: FISH MARKET AQUACULTURE SURVEY
- 4 To Culture or Not to Culture: The Controversy Continues 39**
ACTIVITY: AQUACULTURE DEBATE/TOWN MEETING
- 5 Aquaculture: What's Involved 49**
ACTIVITY: STARTING YOUR OWN AQUACULTURE OPERATION
ACTIVITY: DETERMINING NUMBER BY WEIGHT IN FISH POPULATIONS
- 6 Water: The "Aqua" in Aquaculture 59**
ACTIVITY: SALTWATER WONDERS
ACTIVITY: TESTING THE WATERS
- 7 Aquatic Ecology 75**
ACTIVITY: ECOTRIVIA
ACTIVITY: WEB OF LIFE
- 8 Culturing Finfish 87**
ACTIVITY: KEYING OUT FISH
ACTIVITY: AGING FISH
ACTIVITY: BONY FISH DISSECTION
- 9 Culturing Shellfish and Sea Vegetables 113**
ACTIVITY: MUSSEL DISSECTION
- 10 Aquaculture in the Classroom 131**
ACTIVITY: GROWING FRESHWATER ALGAE
ACTIVITY: MARINE ALGAE AND LIGHT
ACTIVITY: GROWING CLAMS

- APPENDIX A: Water Quality Variables
- APPENDIX B: Identification of Seaweeds and Marine Organisms
- APPENDIX C: Field Trip to a Rocky Shore
- APPENDIX D: Adaptations to Survive on a Rocky Beach
- APPENDIX E: Field Guide to Seaside Plants and Coastal Organisms
- APPENDIX F: Cleaning and Dressing Fish
- APPENDIX G: Shellfish Species Characteristics
- APPENDIX H: Map: Mairfe's Aquaculture Sites
- APPENDIX I: State of Maine Learning Results

WRITER: Katie Sucoff, University of Maine (UM) College of Education
EDITOR: Susan White, Maine/New Hampshire Sea Grant College Program
DESIGN/LAYOUT: MaJo Keleshian, Me/NH Sea Grant College Program
EDUCATIONAL CONSULTANT: Mary Bird, UM College of Education
PROJECT COORDINATOR: Michael Hastings, Maine Aquaculture Innovation Center
CURRICULUM CONSULTANTS: Patricia Bernhardt and Sarah Winne, Bangor School Department

We would like to thank everyone who helped develop *Aquaculture in Maine: A Curriculum Guide for Secondary School Teachers*. The level of support and cooperation from people across the state was truly inspirational.

Special thanks go to the following individuals whose time, effort, and expertise insured the success of this project: Seth Barker and Elaine Jones, Maine Department of Marine Resources; Esperanza Stancioff, Cathy Elliott, Mike Opitz, and Gary Anderson, University of Maine Cooperative Extension; Dick Paul, University of Maine at Machias; Jane Lamson, Downeast Resource Conservation and Development (RC & D); Chris Bartlett, Maine/New Hampshire Sea Grant College Program; and Sam Chapman, Time and Tide RC & D.

The Aquaculture Education Coalition*, which prepared, published, and tested the *Aquaculture in Maine* curriculum guide, wishes to express its special thanks to the Maine Science and Technology Foundation and the Maine Community Foundation, each of which provided major funding support for this project.



*The Aquaculture Education Coalition consists of representatives of the Maine/New Hampshire Sea Grant Program, Time and Tide RC & D, Maine Department of Marine Resources, Maine Aquaculture Innovation Center, Maine Aquaculture Association, and the University of Maine Cooperative Extension.

A Note on

MAINE'S LEARNING RESULTS

Determining What Students Should Know and Be Able to Do

Each chapter in the *Aquaculture in Maine* curriculum guide includes a section describing how the various activities incorporate the **State of Maine Learning Results**. Letters and numbers appearing below each of the activities refer to the Science and Technology content standards and the secondary school level of performance indicators, respectively, and coincide with those indexed in Appendix I.

Maine's Learning Results offers three levels of descriptive language which articulate, by grade span, the knowledge and skills that children should acquire through their K-12 public school experience.

- Guiding Principles (Level 1) – Articulates a broad description of an “educated person.”
- Content Standards (Level 2) – Organizes the Learning Results by content areas or disciplines.
- Performance Indicators (Level 3) – Informs the development of assessment measures and daily instruction.

Guiding Principles

Each Maine student will leave school as:
a clear and effective communicator.
a self-directed and lifelong learner.
a creative and practical problem solver.
a responsible and involved citizen.
a collaborative and involved citizen.
a collaborative and quality worker.
an integrative and informed thinker.

Science and Technology Content Area

The rapid changes to our understanding of the world demand that students learn to access, understand, and evaluate up-to-date information through the study of science and technology. While science is concerned with understanding the natural world, technology deals with human-made solutions. Science and technology impact and are impacted by all other content areas, and this interconnectedness must be a significant part of all learning.

Developing curiosity and excitement in science and technology, while gaining essential knowledge and skills, is best achieved by engaging students as active learners who experience and apply science rather than absorb and parrot it. Standards J-L describe essential skills that should run throughout the curriculum. Standards A-I encompass the subject matter conventionally referred to as biology, physics, chemistry, and earth science.

Introduction to Aquaculture

KEY CONCEPTS

Aquaculture is the controlled cultivation and harvest of aquatic animals and plants. There are many similarities between aquaculture and agriculture, but there are some important differences as well. Aquaculture, like agriculture, is necessary in order to meet the food demands of a growing global population with diminishing natural fisheries stocks. Unlike land under cultivation, the world's oceans, lakes, rivers, and streams are usually public or common resources. Managing these common resources is often problematic.

LESSON OVERVIEW

Students will read a handout which introduces them to the topic of aquaculture. The class will conduct an aquaculture brainstorming session. Cooperative learning groups will explore the “commons dilemma” through a hands-on activity. Students will connect what they learned in the “Aquaculture and the Global Commons” activity to what they know about aquaculture.

LEARNING OBJECTIVES

After completing this chapter, the student will be able to:

- Define aquaculture.
- Distinguish between aquaculture and agriculture.
- Explain different types of aquaculture.
- Distinguish between warmwater, coldwater, and maricultured species.
- Describe the outcomes of a self-interest strategy vs. a cooperative strategy for managing a renewable resource.
- Enumerate the complex factors involved in managing a global public resource.
- Apply math skills to natural resource management problems.
- Apply analytic skills to natural resource management problems.

LEARNING RESULTS

AQUACULTURE AND THE GLOBAL COMMONS

- B. Ecology:** Students will understand how living things depend on one another and on non-living aspects of the environment.
3. Analyze the effect of reproductive and survival rates on population size.
 4. Analyze the impact of human and non-human activities on the type and pace of change in ecosystems.
- J. Inquiry and Problem Solving:** Students will apply inquiry and problem solving approaches in science and technology.
2. Verify, evaluate, and use results in a purposeful way. This includes analyzing and interpreting data, making predictions based on observed patterns, testing solutions against the original problem conditions, and formulating additional questions.
- K. Scientific Reasoning:** Students will learn to formulate and justify ideas and to make informed decisions.
3. Develop generalizations based on observations.
 5. Produce inductive and deductive arguments to support conjecture.

- L. **Communication:** Students will communicate effectively in science and technology.
5. Critique models, stating how they do and do not effectively represent the real phenomenon.

MATERIALS

Copies of student handout, chart paper, and markers (brainstorming session); 2 pounds of peanuts in the shell* or styrofoam packing material and one large bowl for every cooperative learning group made up of approximately four students (“Aquaculture and the Global Commons” activity).
(*Keep in mind that some students may have food allergies or dietary restrictions.)

BACKGROUND

What is aquaculture?

Word breakdown: Aqua (water) culture (to grow)

Aquaculture is:

- The art, science, and business of producing aquatic plants and animals useful to humans.
- The controlled cultivation and harvest of aquatic animals and plants.

Mariculture is:

- The raising of such crops in the sea.

Are aquaculture and agriculture similar?

Aquaculture can be viewed as a type of agriculture. Aquaculture, like agriculture, is the cultivation and harvest of plants and animals for human use. In essence, aquaculture and agriculture are both farming. However, aquaculture is farming in water and therefore requires a different set of knowledge, skills, and technology.

Which aquatic species are cultured in which environments?

Aquaculture takes place in three general aquatic environments:

1. **Warmwater aquaculture** is culturing plants and animals which thrive in warm, fresh water such as catfish, crayfish, baitfish, sportfish, and ornamental fish.
2. **Coldwater aquaculture** is culturing species which thrive in cool, fresh water such as trout and salmon.
3. **Mariculture** (marine culture) is culturing plants and animals which are accustomed to living in a saltwater or **brackish** environment. Species include clams, oysters, seaweed, mussels and shrimp, salmon, and steelhead trout.

Who practices aquaculture and why?

Aquatic plants and animals are cultured for a variety of reasons. For simplicity, let’s separate aquaculture into two broad categories: public sector and private sector aquaculture.

Public sector/restoration aquaculture is generally aimed at replenishing depleted fishery stocks to benefit all. It tends to be conducted by non-profit organizations, or by the state and federal government. Motivations for public sector aquaculture vary. Sometimes officials are attempting to protect a potentially threatened species such as the Atlantic salmon. When fish are raised to restock depleted waters, we will refer to it as *restoration* aquaculture. Another motivation for public sector aquaculture initiatives are to replenish depleted commercial fishery stocks to enhance the local fishing economy.

Private sector aquaculture has profit as its main motive. Aquaculture entrepreneurs range from individuals to large corporations. Their goal is to sell their product for a profit. The product may be fish or shellfish for a local, regional, or national market; seaweed for a global market; or ornamental fish for aquaria.

What are the different stages of aquaculture?

For finfish . . .

Hatchery: Place where young are produced and often parental broodstock are maintained.

Nursery: Place where newly hatched fry are housed and cared for.

Grow-out facility: Place where young are grown to market size in a variety of holding facilities which include ponds, tanks, raceways, cages, vats, and pens.

Harvesting: Gathering or capturing the cultured aquatic species for marketing or processing.

Processing: Converting the raw product to final form for sale, ranging from minimal to value-added.

Marketing: Getting the product from the producer to the consumer.

For shellfish . . .

Hatchery: Place where broodstock are maintained and spawning and fertilization are initiated.

Nurseries: Place where juvenile shellfish are raised, often in floating trays where they are fed marine algae.

Grow Out: Process whereby young shellfish are seeded on mud flats, placed on the bottom, or suspended in the water column.

Harvesting: Gathering or capturing the cultured aquatic species for marketing or processing.

Processing: Converting the raw product to final form for sale, ranging from minimal to value-added.

Marketing: Getting the product from the producer to the consumer.

ACTIVITY: AQUACULTURE AND THE GLOBAL COMMONS

(Used with permission through arrangement with Schlitz Audubon Center of the National Audubon Society, 1111 East Brown Deer Road, Milwaukee, WI 53217. Reprinted from copyrighted material, Living Lightly on the Planet. All rights reserved.)

Information

Although aquaculture has been around for thousands of years, many people are still unclear about the nature of aquaculture and its place in society. Only a small percentage of global fish production stems from aquaculture; the overwhelming majority is wild capture. Now, with many commercial fisheries in decline, we must turn to alternative food technologies. Aquaculture research and development may provide a partial answer to the difficult problem of managing a dwindling natural resource. In order to understand how our fisheries predicament evolved, we must turn to the global commons. As global population increases, more and more pressure is put on our diminishing natural fish stocks because the oceans are a common public resource to which everyone has access.

The interrelated problem of population growth and dwindling resources is illustrated in this demonstration of the "commons dilemma." Christened by Garrett Hardin, the commons dilemma is derived from *The Tragedy of the Commons* written by William Forester Lloyd in 1833. The commons described by Lloyd is a pasture open to all. Herdsmen bring cattle to the commons to graze. Over time, each herdsman seeks to maximize his economic gain and adds cattle to his

herd. The positive component, the increased profit, is realized by the individual herdsman. The negative component, the resultant overgrazing, is shared by all who use the commons. As each seeks to maximize his gain, the commons resource declines until overgrazing leads to its destruction. The dilemma: self-interest versus cooperation, or maximizing individual gain versus cooperative stewardship of a resource.

Preparation

Photocopy and distribute the student handouts entitled *Aquaculture: What Is It All About?* to the students the day before so that your students will have a chance to read them prior to class.

Procedure

1. Introduce the unit or lesson with a brainstorming session to engage students in the topic and to determine their current level of knowledge about aquaculture. This could be done as a whole-class activity or in cooperative learning groups. Explore ways in which aquaculture connects with their lives. Some students might have relatives working in aquaculture, or live near an aquaculture facility. The goal is to have your class generate a concept map or descriptive list about aquaculture which can be reproduced, distributed, and revisited at the end of the unit.
2. Invite students to consider water resource issues associated with aquaculture. Who owns the oceans, bays, or rivers of the world? The people or nations that surround them? The organisms that occupy them? What happens to the fisheries as the human population rises?
3. Facilitate the commons dilemma demonstration. In this simulation, your students will have an opportunity to demonstrate their response as consumers of a resource in a commons. A large bowl (the commons) represents the sea, and peanuts or styrofoam packing material represent fish (the resource).
4. Introduce the demonstration with a discussion of the ground rules, supplying only the information needed to get the students started. The dilemma and a discussion of the various strategies should surface at the outcome of the activity. Divide students into groups of four and give each a bowl with 16 "fish."

Ground Rules

- The object of the game is to harvest as many fish as possible from the sea.
- At carrying capacity, there are 16 fish (peanuts) in this sea (bowl). For every four fish each student harvests, he/she will receive one point. The more fish you harvest, the more points you will receive.
- When the game begins, you may harvest all of the fish, some of the fish, or none.
- You will have four, 20-second trials in which to harvest fish. You will be notified when to start and stop each trial.
- If fish remain in the sea after each trial, a new fish will be added for each one remaining. If there are four fish left, four more can be added. But for each new trial, the total number of fish in the sea cannot be more than the carrying capacity of 16 fish.

5. Repeat the demonstration with eight students in each group to simulate population growth. Keep all other factors constant.
6. Engage the students in the following discussion of their experience.

Discussion

1. What were the maximum number of points achieved by any individual? Any group?
2. Why were fish only replaced if some remained in the bowl after the trial?
 - It simulates natural conditions; if all fish are harvested, no additional fish will be born.
3. Why is the population of the “sea” limited to 16 fish?
 - Carrying capacity represents the maximum number of organisms that can be supported by an ecosystem.
4. What happens when members of a group do not use a cooperative strategy?
5. What was the best strategy for harvesting from this commons?
 - Harvest eight from each trial.
6. Does this model realistically represent the the real phenomenon of fishing within our oceans?
 - Other variables may affect the population of fish, including non-human predators, dissolved oxygen, water temperature, food supply, and disease.
7. What other human activities threaten the oceans and its inhabitants?
 - Ocean dumping of municipal, industrial and hazardous waste
 - Oil spills and oil drilling
 - Fishing practices which harm other marine wildlife such as whales, dolphins, and sea turtles
 - Nonpoint source pollution such as stormwater runoff
 - Coastal development
 - Industrial and municipal sewage
8. How does aquaculture relate to the commons dilemma?
 - If we culture more aquatic species and catch less wild species, depleted fish stocks will begin to recover.
9. Aquaculture alone will not solve the commons dilemma. Why?
 - Global population is still rising.
 - Cooperation is needed between different nations, corporations, fisherman, and aquaculturists.
 - National and international regulations are needed.
 - Many aquatic species which are being overharvested are not currently being cultured.

STUDENT HANDOUT

Aquaculture: What Is It All About?

The practice of “farming” **aquatic** plants and animals (or aquaculture) has been going on for many centuries. Since **prehistoric** times, obtaining food has been a struggle and a necessity for humans. Early humans were **hunter-gatherers**, which meant that members of the community would venture into the wild to **hunt** animals such as bear, moose, deer, beaver, fish, and other small mammals and reptiles, while others would **gather** food including fruits, berries, nuts, herbs, roots and grubs (insect larvae).

Many societies moved from hunting and gathering to **culturing** their food. In addition to **domesticating** and **cultivating terrestrial** plants and animals, aquatic species were cultured as well. The culture of plants and animals useful to humans is called **agriculture**; when it takes place in water, it is called **aquaculture**. Therefore, aquaculture is a type of agriculture. The method, equipment, and technology is quite different, but the rationale is similar. It is more convenient to choose particular wild species to **domesticate**, cultivate, and **harvest**.

Just as animals have been over-hunted in the past, fish and shellfish have been **overfished** as well. If an animal is hunted beyond a **sustainable** level, it is said to be **depleted**, **overharvested**, or **overexploited**. Throughout the world, **marine** fisheries are in trouble. While the world’s population and its appetite for fish are growing, wild fish stocks are shrinking. According to the U.N. Food and Agricultural Organization (FAO), about 60% of the **commercial** species in every ocean and sea are either depleted or fully exploited today. “It’s like **deforestation**, but you can’t see it under the ocean,” explained a World Bank fisheries advisor in a recent article in *National Fisherman*.

Between 1950 and 1988, the human population has doubled from 2.5 billion to 5 billion. In response to this increase in mouths to feed and people to employ, world fish production has more than quadrupled from 21 million metric tons (mmt) to 98 mmt. Of the 98 mmt of fish production, only 14 mmt came from aquaculture; the remaining 84 mmt came from wild capture. As we take more and more fish from our waters, there are less fish left behind to produce the next generation of fish. By the year 2000, the global human population is expected to reach 6 billion and annual fish production to reach 138 mmt. With global fisheries in decline, aquaculture is the *only* way we can attempt to make up the difference and meet the seafood demands of a growing population.

As the total worldwide marine catch continues to fall, the harvest from aquaculture is rising. By the 21st century, aquaculture will be a major new agricultural growth industry. If managed properly, aquaculture can help overfished species recover, employ people, feed a growing population, and help our local, regional, and national economy.

MAKING CONNECTIONS: ADDITIONAL ACTIVITIES AND EXTENSIONS

• Taking Action

Is there a commons dilemma to be resolved in your community? Have students (or groups of students) select a local commons issue to investigate. Once students have identified the problem and collected data, they should determine which laws exist to protect the resource they are investigating, and then try to come up with a solution to the problem.

• Local Fishery Resources

Many of the fish that once inhabited the Gulf of Maine have been overharvested. Have students, or a group of students, choose a local species which has been overharvested and determine its past and present status, management, and whether it is being cultured or considered for culture.

• Global Planning

There have been successful international efforts to solve some of our global environmental problems. One example is the *Montreal Protocol on Substances that Deplete the Ozone Layer*—referring to the beneficial ozone found in the upper atmosphere that protects us from the harmful rays of the sun. Another largely successful international effort has been the establishment of the International Whaling Commission (IWC) which seeks to end the global slaughter of whales. Have students devise an international management plan for the oceans which would protect species from being overharvested.

GLOSSARY

Agriculture: The art, science, and business of producing every kind of plant and animal useful to humans.

Aquaculture: The art, science, and business of producing aquatic plants and animals useful to humans. The controlled cultivation and harvest of aquatic animals and plants.

Aquatic: An organism that lives in, on, or near the water.

Brackish: Water that contains some salt, but not as much as the ocean.

Carrying Capacity: The maximum number of individual organisms that can be supported by an ecosystem.

Coldwater Species: Aquatic animals that spawn at temperatures below 60° F (15° C).

Commercial: Those fish species which are raised or harvested for market sale.

Cultivate: To grow or tend a plant or crop.

Deforestation: The practice of cutting down or clearing away trees from a forest.

Depleted: Decreased, used up, or emptied out.

Domesticate: To train or adapt a plant or animal to live in a human environment for human use.

Exploit: To utilize for personal gain.

Extinction: The complete elimination of a species.

Finfish: Any true fish (bony, cartilaginous, or jawless) which has a spindle-shaped body and fins.

Grow-out: Place where young are raised to market size.

Harvest: To gather or capture aquatic species for marketing or processing.

Hatchery: Place where seed or young fish produced.

Hunter-Gatherers: Humans who hunt wild animals and gather wild plants for food.

Mariculture: A type of aquaculture which cultures animals and plants in seawater.

Marine: Having to do with salt water.

Organism: An individual form of life, such as a plant, animal, bacterium, protist, or fungi.

Overexploited: To utilize a resource beyond a sustainable level.

Overfish: To collect so many fish from the wild that the population can no longer sustain itself.
Overharvest: To gather so many plants and animals from the wild that the population can no longer sustain itself.
Marketing: The process of getting the product from the producer to the consumer.
Nursery: Place where newly hatched fry are housed and cared for.
Prehistoric: Of, relating to, or belonging to the era before recorded history.
Processing: Conversion of raw product to final saleable form.
Shellfish: An aquatic invertebrate animal with a shell. Especially an edible mollusk or crustacean.
Spawn: The mixing of sperm and eggs to produce young. (i.e., fertilization)
Species: A group of organisms that resemble one another closely.
Sustainable: Economic development that takes full account of the environmental consequences of economic activity and is based on the use of resources that can be renewed or replaced and therefore are not depleted.
Traditional Fisheries: Business of harvesting wild aquatic organisms for sale.
Terrestrial: Living on land.
Warmwater Species: Aquatic animals that spawn at temperatures above 60° F (15°C).
Wild: Occurring, growing, or living in a natural state; not domesticated, cultivated, or tamed.

ADDITIONAL RESOURCES

McVey, Eileen. *Aqua-Topics: Aquaculture for Youth and Youth Educators*. Beltsville, MD: Aquaculture Information Center-Public Services Division, 1989. 19 pp.
Northeast Fisheries Science Center. *Status of the Fishery Resources Off the Northeastern United States*. NOAA Tech. Memorandum NMFS-NE-108. Woods Hole, MA. Jan. 1995.
Parker, Rick, Rosemary Vaughn and Terry Patterson. *Aquaculture Science*. Delmar Publishers, 1995. 660 pp.
Quest: Investigating the World We Call Maine, Episode #4: "Gulf of Maine." Maine Public Television, November 1995.
Texas A&M University. *Exploring Aquaculture: Curriculum Guide for Agriscience 282*. College Station: Texas A&M Dept. of Agricultural Science, 1992. 22 pp.
The Council for Agricultural Education. *Aquaculture*. Alexandria, VA, 1992.

Aquaculture Around the World:

Where Did It Come From and Where Is It Going?

KEY CONCEPTS

Aquaculture may seem to us like a relatively new scientific venture, but it has a very long and rich history. The roots of aquaculture can be traced back to 3500 B.C. in China. Asia is still, by far, the leader in aquaculture production. In the United States, aquaculture is a small, yet growing, industry. U.S. national policy encourages this growth for the dual purpose of reducing the U.S. trade deficit and for replenishing depleted wild fish stocks.

LESSON OVERVIEW

Students will learn about the history of aquaculture around the world and construct a timeline which will place aquaculture milestones in context with key world events. Students will calculate figures and construct graphs and charts based on global aquaculture production statistics. Students will research different countries and their contribution to global aquaculture production.

LEARNING OBJECTIVES

After completing this chapter, the student will be able to:

- Describe the history of aquaculture around the world.
- Explain the current global status of aquaculture.
- Describe the production status of individual countries.
- Identify several countries and continents critical to aquaculture production and locate them on a map of the world.
- Enumerate the important contributions that many different cultures have made to aquaculture.
- Demonstrate math skills such as adding, subtracting, multiplying, dividing, calculating proportions and percentages and applying basic algebra.
- Demonstrate analytical math skills and apply them to real global aquaculture statistics.
- Develop a pie chart and a bar graph based on global aquaculture statistics.
- Analyze and interpret data.
- Demonstrate research skills.

LEARNING RESULTS

AQUACULTURE TIMELINE

M. Implications of Science and Technology: Students will understand the historic, social, economic, environmental, and ethical implications related to science and technology.

5. Examine the historic relationships between prevailing cultural beliefs and breakthroughs in science and technology.

GLOBAL GRAPHING

M. Implications of Science and Technology

1. Examine the impact of political decisions on science and technology.

MATERIALS

World map, overhead of *Aquaculture Timeline*, overhead projector, index cards, markers, flags or pushpins, copies of student handouts, map of the world, graph paper, calculators (optional), computer spreadsheet/graphing program (optional), world almanac, research materials.

BACKGROUND

Based on written documents, it is believed that aquaculture began in China around 3500 B.C. Culturing fish may have evolved from the practice of storing fish in ponds until they are ready to be eaten. The Chinese developed the use of **polyculture**, the art of growing more than one species at a time. They determined that many different species of **carp** could coexist in the same pond because they lived in different parts of the water and fed on different organisms. With polyculture, more fish could be raised in a given area. Originally, aquaculture was designed only for the wealthy elite who wished to have fresh fish all year long. Later, it became a way to provide food for the masses.

Based on drawings which date back to 2000 B.C., historians determined that Egyptians cultured **tilapia**. It is likely that the practice of aquaculture evolved from their advanced system of irrigation. Mayan Indians trapped and culture fish between 500 and 800 B.C. By 100 B.C., wealthy members of the Roman empire enjoyed mullet and trout reared in ponds called "stews." They were the first to experiment with both saltwater and freshwater culture. As far back as 400 A.D., Hawaiians utilized extensive pond systems for aquaculture. They raised species in fresh, salt, and brackish water. It was not until the end of the 11th century that aquaculture took hold in Europe. In the United States, culturing trout began in earnest in the mid 1800s. To this day, the United States lags behind much of the world in aquaculture production. China is still the leader in aquaculture production. All of Asia makes up around 85% of the total global aquaculture production. In contrast, the U.S. produces only 2% of the world's total aquaculture production.

A variety of experts are needed to unravel the history of aquaculture, which may include deciphering ancient writings and pictures, archaeological excavation, and carbon-dating. "Modern" aquaculture usually involves sophisticated technology, but does not necessarily imply "better" aquaculture. Many less developed countries still practice very successful, low technology aquaculture.

ACTIVITY 1: AQUACULTURE TIMELINE

Preparation

Student groups will need index cards and access to a world map and a world almanac.

Procedure

1. Using a map of the world and the overhead provided, trace the evolution of aquaculture through time. Point out that these dates are approximate. Determine whether students understand the B.C./A.D. distinction. Try to get students thinking about how timelines are created. How did historians trace the history of aquaculture back 3500 years?
2. Divide the class into three groups. Assign each group a particular area of the world such as the Americas, Europe, and Asia/Africa. Give each group a world almanac. Have each group brainstorm (with the help of the almanac and teacher) pivotal events in history in their region. Then choose five pivotal historical events and write down the event and date on an index card. Each group will also fill out an index card for any relevant aquaculture event in their region.

3. As a class, create a "History of the World Timeline" by pasting, taping, or stringing the various index cards from the three groups in sequence, to be displayed in the classroom or hall. Students will see the history of aquaculture in context with general events in history.
4. After the classroom timeline is complete, have the students from each group apply a "flag" or pushpin to a world map identifying their country or region and the date which reflects that country's milestone in aquaculture history (e.g., Egypt, 2000 B.C.)

Discussion

1. How do the aquaculture systems and practices of the different area and time periods differ?
2. Is there a relationship between any historic event and a breakthrough in aquaculture?
3. What cultural beliefs might account for the acceptance of aquaculture in one area and not in another?
4. What predictions might you make for the future of aquaculture?

OVERHEAD

Aquaculture Timeline

- 3500 B.C. Aquaculture began in **China**. They raised carp, a hardy freshwater species, which is still raised in many parts of the world today. They also developed the use of polyculture, the art of growing different species together.
- 2000 B.C. Drawings dated back to 2000 B.C. indicate that **Egyptians** practiced aquaculture. They cultured tilapia, a warmwater species which is still cultured in many countries today.
- 800 B.C. Archeological evidence indicates that the **Mayan Indians** of Central America cultured fish in ponds and canals.
- 100 B.C. **Romans** practiced both freshwater and saltwater aquaculture. Fish such as trout and mullet were raised in ponds called "stews."
- 400 A.D. **Hawaiian Natives** established an organized system of aquaculture which consisted of a variety of fresh and saltwater systems to raise several species.
- 1100 A.D. Aquaculture began in **Central Europe** with the culture of carp.
- 1800 A.D. **France** began experimenting with modern aquaculture techniques. By the mid 1800s, coldwater trout and salmon were cultured in France and other European countries.
- 1850 A.D. Trout and salmon were cultured in the **United States** for the purpose of restocking lakes and streams for anglers.

Within the last century, aquaculture has expanded nationally and globally. A huge selection of fish, shellfish, and plants are cultured for a variety of purposes.

ACTIVITY 2: GLOBAL GRAPHING

Information

Depending on the level of your students, the following activity can be modified to make it more or less challenging. For younger students, who may not be familiar with algebra, figures can be rounded to whole numbers, estimated, or given in proportions. This activity can work as an individual student exercise, as a take-home assignment, but ideally as a cooperative learning activity.

Preparation

Familiarize students with the countries and geographic areas for which they will be calculating aquaculture productivity: Asia, East Asia, West Asia, Africa, Eastern Europe, Western Europe, Western Hemisphere, etc. Review computational skills and graphing if needed.

Procedure

1. Divide students into cooperative learning groups. Give each student a copy of the student handout entitled *Global Graphing*.
2. Have students work through the mathematical problems and construct graphs.
3. Go over the problems as a class, inviting groups to provide answers.
4. Pass out a copy of the handout *Aquaculture Policy in the U.S.* This may be read in, before, or after class.

Discussion

- What role has the U.S. played in aquaculture in the past, present, and future?
- How does this relate to global aquaculture statistics and the aquaculture timeline?

STUDENT HANDOUT

ACTIVITY: GLOBAL GRAPHING

In 1988, the Food and Agricultural Organization (FAO) gave the following statistics for global aquaculture production:

1. In 1988, global aquaculture yield reached 14 million metric tons (mmt). If global fish production was 98 mmt, what *percentage* of this fish production was cultured?

East Asian Countries (China, Japan, North and South Korea, Taiwan and the Philippines) produce three-fourths of the world's aquaculture production. China produces one-half of all East Asian aquaculture production.

2. How many mmt does East Asia produce?
3. How many mmt does China produce?

West Asian Countries (Indonesia, Vietnam, Thailand, India and Bangladesh) together produce almost 1.5 mmt, bringing the Asian total to 12 mmt.

4. What *percentage* of global aquaculture production is made up by all of Asia?
5. Europe and the former USSR make up 10% of world aquaculture production. How many mmt does that work out to be?
6. Aquaculture in Africa makes up 0.5% of total aquaculture production. How many mmt is Africa producing?
7. The entire western hemisphere produces less than 5% of the total world aquaculture production. How many mmt does the Western Hemisphere produce?

8. The U.S. produces 0.3 mmt of cultured fish. What percentage of total aquaculture production does this amount to?
9. Draw a pie chart which shows the percentages of global aquaculture production for the following countries or areas: (Asia, Europe and former USSR, U.S, Africa, other)
10. Construct a bar graph (on the graph paper provided) of aquaculture production in mmt for the following countries or areas: (Asia, Europe and former USSR, U.S, Africa, other)
11. Based on your answers above, shown by the pie chart and the bar graph you generated, briefly assess global aquaculture production. Do you think it will change? Why do you think that countries within the Eastern Hemisphere culture more fish than the Western Hemisphere?
12. Of the species cultured globally, 4 mmt are algae, 3 mmt are mollusks (oysters, clam, mussels, and scallops) and 7 mmt are finfish. Of the finfish, most are freshwater carp and tilapia raised in Asia. *Less than 1 mmt of all finfish cultured are marine.* Determine the *percentages* of algae, mollusks, and finfish cultured and draw a pie diagram to represent the total.

Algae:

Mollusks:

Finfish:

13. In the U.S., the species listed below are cultured. Construct a bar graph and/or pie chart which represents the distribution of species cultured in the U.S.

Catfish - 49%

Salmon - 10%

Oysters - 5%

Bait/tropical fish - 6%

Trout - 9%

Crawfish - 11%

Others - 10%

HANDOUT (TEACHER COPY)

ACTIVITY: GLOBAL GRAPHING

In 1988 the Food and Agricultural Organization (FAO) gave the following statistics for global aquaculture production:

1. In 1988, global aquaculture yield reached 14 million metric tons (mmt). If global fish production was 98 mmt, what *percentage* of this fish production was cultured?

$$(14/98 = X/100) = 14.3\% \text{ (of total global fish production came from aquaculture)}$$

East Asian Countries (China, Japan, North and South Korea, Taiwan and the Philippines) produce three-fourths of the world's aquaculture production. China produces one-half of all East Asian aquaculture production.

2. How many mmt does East Asia produce?

$$(14) (3/4) = 10.5 \text{ mmt}$$

3. How many mmt does China produce?

$$(10.5) (1/2) = 5.25 \text{ mmt}$$

West Asian Countries (Indonesia, Vietnam, Thailand, India and Bangladesh) together produce almost 1.5 mmt, bringing the Asian total to 12 mmt.

4. What percentage of global aquaculture production is made up by all of Asia?

$$(12/14) = X/100 = 85.7\%$$

5. Europe and the former USSR make up 10% of world aquaculture production. How many mmt does that work out to be?

$$(14) (.1) = 1.4 \text{ mmt}$$

6. Aquaculture in Africa makes up 0.5% of total aquaculture production. How many mmt is Africa producing?

$$(14) (.005) = .07 \text{ mmt}$$

7. The entire western hemisphere produces less than 5% of the total world aquaculture production. How many mmt does the Western Hemisphere produce?

$$(14) (.05) = 0.7 \text{ mmt}$$

8. The U.S. produces 0.3 mmt of cultured fish. What percentage of total aquaculture production does this amount to?

$$(.3) (14) = X/100 = 2.1 \%$$

9. Draw a pie chart which shows the percentages of global aquaculture production for the following countries or areas: (Asia, Europe and former USSR, U.S, Africa, other)

10. Construct a bar graph (on the graph paper provided) of aquaculture production in mmt for the following countries or areas: (Asia, Europe and former USSR, U.S, Africa, other)

11. Based on your answers above, shown by the pie chart and the bar graph you generated, briefly assess global aquaculture production. Do you think it will change? Why do you think that countries within the Eastern Hemisphere culture more fish than the Western Hemisphere?

12. Of the species cultured globally, 4 mmt are algae, 3 mmt are mollusks (oysters, clam, mussels, and scallops) and 7 mmt are finfish. Of the finfish, most are freshwater carp and tilapia raised in Asia. *Less than 1 mmt of all finfish cultured are marine.* Determine the percentages of algae, mollusks and finfish cultured and draw a pie diagram to represent the total.

$$\text{Algae: } (4)/(14) = (X)/(100) = 28.6 \%$$

$$\text{Mollusks: } (3)/(14) = (X)/(100) = 21.4 \%$$

$$\text{Finfish: } (7)/(14) = (X)/(100) = 50 \%$$

13. In the U.S., the species listed below are cultured. Construct a bar graph and/or pie chart which represents the distribution of species cultured in the U.S.

Catfish - 49%

Salmon - 10%

Oysters - 5%

Bait/tropical fish - 6%

Trout - 9%

Crawfish - 11%

Others - 10%

Charts and Graphs

9. Global Aquaculture Production (in %) 10. Global Aquaculture Production (in mmt)

1 = Asia 2 = Europe 3 = Former USSR 4 = United States 5 = Africa & others

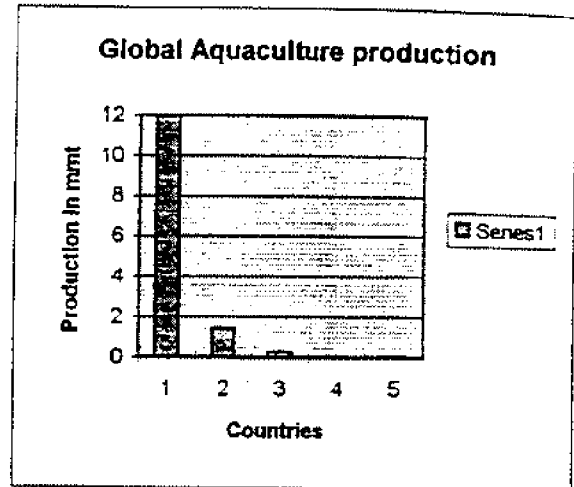
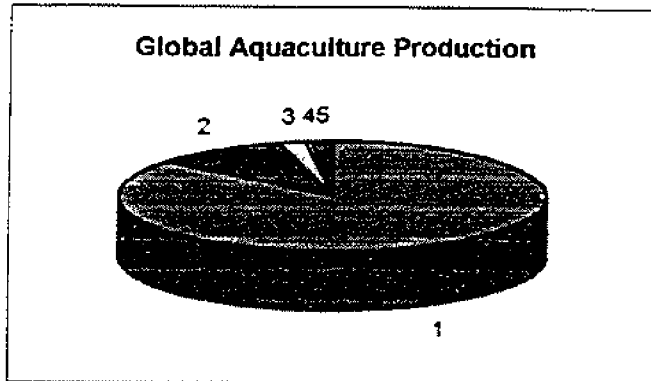

12. Species cultured in the U.S. (in %)

1 = Catfish 2 = Crawfish 3 = Salmon 4 = Trout 5 = Bait/tropical fish 6 = Oysters
7 = Others

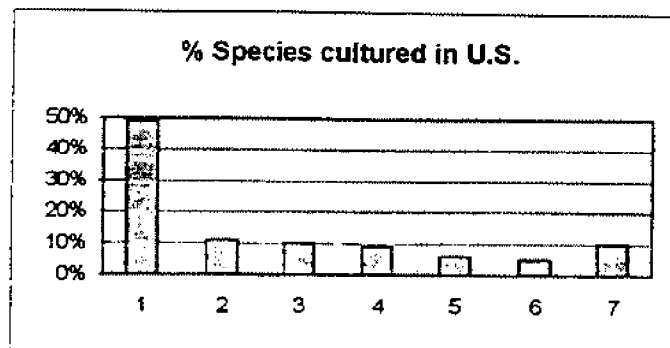
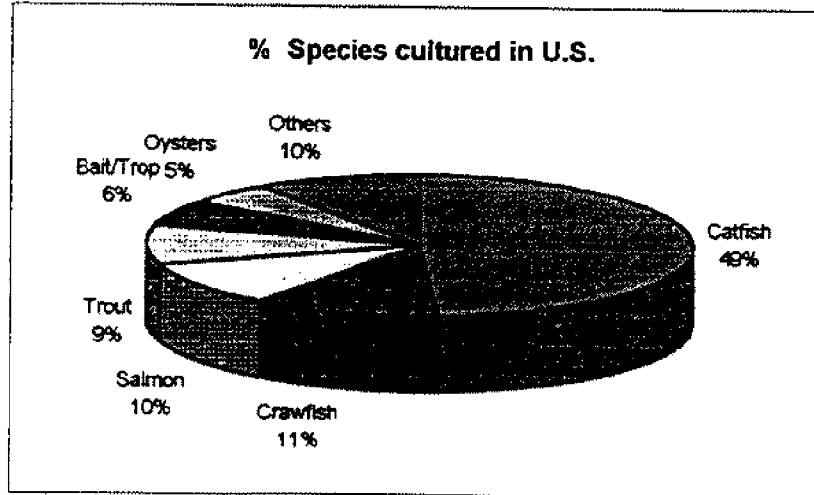

STUDENT HANDOUT

Aquaculture Policy in the U.S.

In 1980, The National Aquaculture Act (P.L. 96-362) made **aquaculture** a national priority in the United States. The law was enacted because so many **commercial** fish had been **depleted** and our national fisheries **trade deficit** was rising. A trade deficit occurs when a nation **imports** more than it **exports**. The U.S. is the second largest importer of seafood in the world. Over the last 20 years, people in the U.S. have demanded more seafood, largely due to the health benefits associated with eating seafood. Less than 40% of the seafood we consume has been caught, **harvested**, or raised in the U.S. Therefore, the majority of the seafood we, as a nation, consume is imported from other countries. Between 1980 and 1990, aquaculture production in the U.S. tripled, making aquaculture the fastest growing type of agriculture in the U.S. However, the U.S. fishery trade deficit rose from 2.6 billion in 1980 to 5.5 billion in 1990, so we still have a long way to go if we want to reverse our trade deficit. We can no longer turn to traditional fisheries to solve the problem since they are in decline throughout the world, due to management problems, overfishing, and environmental problems. Instead, the U.S. could seize this major opportunity to develop an internationally competitive aquaculture industry.

Mariculture: An Unrealized Potential

Of the 0.3 mmt of fish cultured in the U.S., nearly three-fourths is grown in fresh water. These freshwater species include catfish, crayfish, rainbow trout, ornamental fish and baitfish for commercial, recreational, and stocking purposes. Marine aquaculture, or **mariculture**, makes up the remaining one-fourth of all cultured fish in the U.S. Oyster culture makes up the bulk of all maricultured species (80%). Clams, mussels, salmon, and shrimp make up the rest (20%).

MAKING CONNECTIONS: ADDITIONAL ACTIVITIES AND EXTENSIONS

- Have each cooperative learning group research aquaculture in a particular country, region, or continent. This research would give the students an opportunity to compare and contrast the way different countries practice aquaculture, and how it relates to their culture and politics. This group project could culminate in a research paper and/or a class presentation.

GLOSSARY

Aquaculture: The art, science, and business of producing aquatic plants and animals useful to humans. The controlled cultivation and harvest of aquatic animals and plants.

Carp: Hardy, freshwater fish cultured throughout much of the world.

Commercial: Those fish species which are raised or harvested for market sale.

Depleted: Decreased, used up, or emptied out.

Export: To send or transport a product to another country for trade or sale.

Harvest: To gather or capture fish for marketing and processing.

Import: To bring a product from a foreign country for trade or sale.

Mariculture: A type of aquaculture which cultures animals and plants in seawater.

Polyculture: Raising two or more species in the same pond or enclosure.

Tilapia: A warm, freshwater fish native to Africa, which is cultured throughout much of the world.

Trade Deficit: When a nation spends more money importing a product than it gains from exporting that product.

Traditional Fisheries: Business of harvesting wild aquatic organisms for sale.

ADDITIONAL RESOURCES

Cross, Douglass. "FAO & Aquaculture: Ponds and Politics in Africa." *The Ecologist* 21(2): 73; 1991.

Kelley, Ken. "Japanese Fish Farming." *National Fisherman* Apr. 1994: 58.

Levi, Carolyn, "Growing Fish Salad: An Experiment in Integrated Aquaculture." *Nor'easter* Spring 1991: 15.

National Research Council. *Marine Aquaculture: Opportunities for Growth*. Washington: National Academy Press, 1992.

Swift, Donald R. *Aquaculture Training Manual*. Cambridge, MA: Fishing News Books-Blackwell Science Publications, 1993.

Aquaculture in Maine

KEY CONCEPTS

For many reasons, Maine is an ideal place for certain kinds of aquaculture, particularly mariculture. Since the 1970s, there have been many advances in culturing finfish, shellfish, and sea vegetables in Maine.

LESSON OVERVIEW

Students will read about and discuss the practice of aquaculture in Maine. Aquaculture sites in Maine will be identified and marked on a map. The class will collaborate on a class newsletter which focuses on aquaculture in Maine. Students will conduct an aquaculture survey at a local fish market and tour a local aquaculture facility.

LEARNING OBJECTIVES

After completing this chapter, the student will be able to:

- Explain major events in the history of aquaculture in Maine.
- Identify the three broad groups cultured in Maine (finfish, shellfish, sea vegetables).
- Identify the species cultured within the three groups.
- Locate aquaculture sites on a map of Maine.
- Explain the important cultural aspects of aquaculture in Maine.
- Identify environmental factors influencing aquaculture site locations.

LEARNING RESULTS

MAPPING MAINE'S AQUACULTURE SITES

K. Scientific Reasoning: Students will learn to formulate and justify ideas and make informed decisions.

3. Develop generalizations based on observations.

L. Communication: Students will communicate effectively in science and technology.

3. Make and use appropriate symbols, pictures, diagrams, scale drawings, and models to represent and simplify real-life situations and solve problems.

AQUACULTURE NEWSLETTER

L. Communication

2. Use journals and self assessment to describe and analyze scientific and technological experiences and to reflect on problem solving processes.

6. Evaluate the communication capabilities of new kinds of media.

FISH MARKET AQUACULTURE SURVEY

J. Inquiry and Problem Solving: Students will apply inquiry and problem solving approaches in science and technology.

1. Make accurate observations using appropriate tools and units of measure.

K. Scientific Reasoning

3. Develop generalizations based on observations.

4. Recognize the need to revise studies to improve their validity through better sampling controls or data analysis techniques.

MATERIALS

Large classroom map of Maine, map “flags” (colored pushpins) and labels (paper cut into small strips), copies of student handout *Aquaculture in Maine*, four copies of the *Aquaculture Map*, copies of student handout *Fish Market Survey*, copy of *List of Aquaculture Facilities in Maine*.

BACKGROUND

(The following information is an excerpt from *The Maine Seacoast*, Sherman Hasbrouck and Kathleen Lignell, a University of Maine Sea Grant publication, 1994.)

The Gulf of Maine

The Gulf of Maine is a body of water 70% enclosed by New England and Canadian land masses. It is really a “sea within a sea,” a 36,000 square-mile basin bounded on the ocean side by Georges Bank and other submerged shelves off Nova Scotia. (These shelves were mainly formed by glacial ice sheets that dredged huge amounts of materials from the mainland and deposited them on the ocean floor.)

The Gulf is a unique body of water because of its size, tidal action, and other characteristics. Its water circulation pattern—called the “Gulf of Maine gyre” is shown on the illustration below. Cold ocean water from the Scotian Shelf off Nova Scotia, runoff from rain and spring snowmelt, and winds and strong tides all contribute to the circulation pattern. (As satellite photographs show, areas of high biological production tend to occur where water movement is strong, especially along the coast and over Georges Bank.)

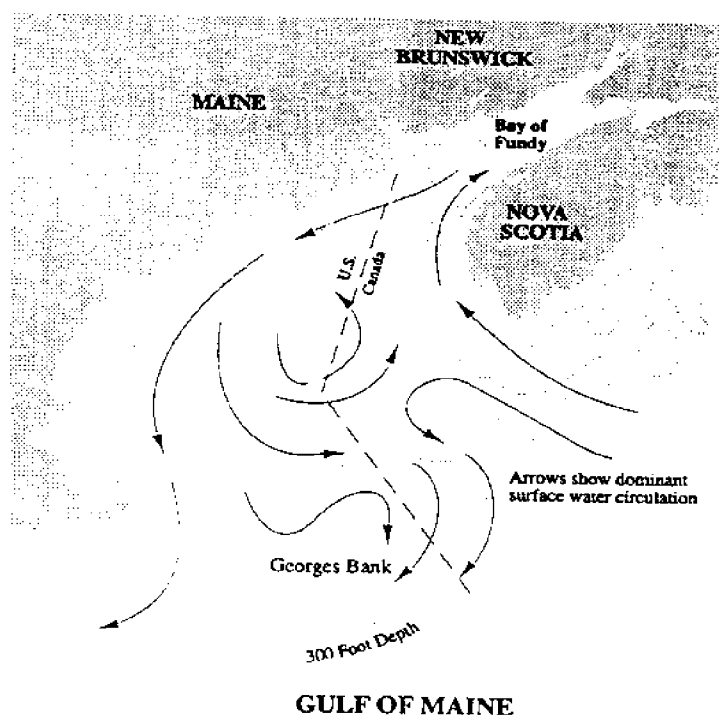

Tides currents, salinity (salt) levels, sedimentation, freshwater input, and cool temperatures all provide the special conditions that contribute to the abundant marine life in the Gulf. Especially important is the process of vertical mixing of bottom waters with surface waters.

The Gulf contains a number of diverse biological habitats and ecosystems that are linked and partially interdependent. The two primary habitat regions are the coastal region and the central gulf.

The coastal region consists primarily of rocky headlands, coves, bays, islands, and occasional sand beaches. Near-shore waters contain many fish species and marine mammals (including whales and harbor seals). The sea bottom in this region is composed of rocks and soft sediments on and in which an array of "benthic" (bottom-dwelling) organisms live (i.e., marine worms and other detritus-feeding organisms). There is also an abundance of rock crabs, sea scallops, ocean quahogs, and surf clams. The most familiar benthic creature is the American lobster.

In the central gulf region, the relatively warm bottom waters and moderate depths (around 500 feet) support a wide variety of fish: e.g., cod, haddock, pollock, swordfish, and redfish (ocean perch).

The Maine Seacoast

It is ironic that rising sea levels are now a matter of concern, since rising sea levels helped create Maine's rugged sea coast. However, historic sea-level changes have been extremely gradual and hardly noticeable.

Yet those changes have had much to do with forming the physical, biological, and social character of Maine's seacoast. Scientists call that coast a "drowned coastline." As a geologically young coast, the sea has not yet had time to pound Maine's seacoast flat. There has not been time for the shore to be weathered into a relatively smooth edge, where shifting sand deposits absorb much of the brunt of the ocean's force. Rather Maine's coast is a place where hard upland bedrocks meet the fury of the rising, incoming sea in full force.

There are, nevertheless, considerable differences in coastal areas in Maine, differences in physical character, marine life, and human settlement. To understand the Maine coast more fully, we must look at three coastal zones: the eastern coast, the midcoast, and the southern coast.

Maine's southern coast extends from Casco Bay to the New Hampshire border. Although some sections are rocky, the southern coast is noted for its sand beaches. The sand was deposited by the glaciers of the last ice age over a large area. (In contrast, the sands of coastal areas below Cape Cod were created by thousands of years of shoreline erosion and weathering.) We thus find, in the southern coast, a shorter, more regular seacoast and

- fewer fish and shellfish areas than those elsewhere in coastal Maine;
- warmer waters than those elsewhere in Maine;
- little contamination of coastal waters; and
- intensive recreational use and tourism.

Maine's midcoast extends from Penobscot Bay to Casco Bay. This coastal area is irregular, like the eastern coast, but shaped more by the rivers that flow southward into the Gulf of Maine. (These rivers drain well over half of Maine's land area.) We find in the midcoast:

- river corridors, like the Kennebec, that historically linked Maine's seacoast with interior forests, agricultural lands, and urban communities;
- Merrymeeting Bay, a large inland tidal area of water and wetland, where the Androscoggin River joins the Kennebec before the combined river flows to the sea;

- superb saltwater boating areas and dozens of protected harbors;
- competing space demands, in those same harbors, by commercial fishermen, recreational boaters, and tourism businesses;
- some pollution of bays and shellfish areas; and
- excellent aquaculture sites (though not comparable, in number and size, to those on Maine's eastern coast).

The eastern coast extends from Passamaquoddy Bay in the east to Penobscot Bay. On this coast we find:

- tides nearly twice as strong and high as those along the southern coast;
- a most irregular coastline with rocky headlands, thousands of islands, and many tidewater bays and salt marshes;
- cold waters and, especially toward the east, frequent foggy days;
- abundant fish, shellfish, seabirds, and other marine life;
- the prime habitat in the world of the American lobster;
- Cobscook Bay, a bay complex with unusually high, strong tides (and some of the best aquaculture sites in the world);
- relatively little urban development and tourism (aside from Mount Desert Island); and
- the largest extent of undeveloped coast remaining in the lower United States—the “bold coast” extending eastward from Machias Bay.

ACTIVITY 1: MAPPING MAINE'S AQUACULTURE SITES

Preparation

Distribute the two student handouts on *Aquaculture in Maine* prior to class.

Procedure

1. Have the students review the *Aquaculture in Maine* handouts at the beginning of class. Based on the student handouts, conduct a brainstorming session on aquaculture in Maine with your class. This could be done as a class activity or in cooperative learning groups. The goal is to have the class generate a list that describes Maine aquaculture which can later be reproduced and distributed. One way to facilitate the brainstorming session is to ask the class a series of questions to introduce the topic such as:
 - *What makes the coast of Maine suitable for aquaculture?*
 - *What species are suitable for aquaculture in Maine?*
 - *How do fisheries and aquaculture complement each other?*
 - *How does technology influence aquaculture?*
 - *Why is it becoming so important to learn how to aquaculture cod, haddock, or halibut?*
2. Divide the class into three teams and give each team a copy of the *Aquaculture Map*. As a class, go through the student handout and pick out all the aquaculture operations mentioned. Then locate them on a large class map of Maine. Mark each location with a clear pushpin and a label identifying the name of the aquaculture operation.

3. Under "Additional Resources," there is a comprehensive list of current aquaculture operations in Maine. Copy and distribute the list to each student. Assign each of the three teams to one of the following categories: 1. finfish, 2. shellfish, and 3. freshwater hatcheries and sea vegetables. Distribute 25 pushpins (of one color) to each team, which will be named after the color of the pushpins they receive (i.e., blue team, red team, and green team).
4. Have each group identify the species cultivated within their category.
5. Have each group locate the aquaculture operations they are responsible for on their own map. Call on members of each group to come up and label aquaculture operations on the large class map. Students will label each site with a paper strip which will have the name of the aquaculture operation, and a colored pushpin.

Discussion

1. Where do you tend to see a concentration of finfish operations, shellfish operations, freshwater hatcheries, or sea vegetable growing sites?
2. What factors influence the locations of a particular type of aquaculture?

STUDENT HANDOUT

Aquaculture in Maine

In the early 1970s, a few **entrepreneurs** first experimented with **commercial** mussel, oyster, coho salmon, and rainbow trout farming in Maine. Since then, aquaculture has grown into a technologically advanced industry worth \$57.5 million to harvesters in 1996. There are 1,282 acres of ocean leased for farming at 80 different sites. More than 690 people work full time on 25 aquafarms in Washington, Hancock, Lincoln, Knox, and York counties where they raise Atlantic salmon, steelhead trout, mussels, and oysters. In finfish culture, the harvest has grown from a 1988 **landing** of 1 million pounds to over 22 million pounds in 1996. Research conducted by Maine scientists may make raising cod, haddock, and halibut practical and cost-effective in the future.

Because Maine has protected bays with generally clean and nutrient-rich waters with large tides, the entire coast is suitable for aquaculture in one form or another. The greatest concentration of finfish operations is in Downeast Maine where winter water temperatures tend to be higher than the deep narrow **estuaries** west of Penobscot Bay. Most shellfish farms are in the midcoast region. Maine's lakes, with their abundance of clean water, are also ideal places for freshwater finfish hatcheries.

Although sometimes seen as rivals, aquaculture and traditional fisheries can complement each other. Several projects in the state prove the beneficial relationship between the two. Aquaculture can provide off-season or additional jobs for people involved in traditional fisheries, and fishermen can apply their skills and know-how to aquaculture.

Maine's strategy for developing aquaculture in the state has included promoting cooperation among university and technical college researchers, industry and government personnel, and those involved in traditional fisheries and aquaculture. Maine is committed to encouraging the development and distribution of information on aquaculture, developing a positive investment climate for small entrepreneurs, coordinating aquaculture and traditional fisheries, and ensuring efficient and effective regulations while monitoring and preserving coastal water quality.

Maine's Aquaculture History: A Closer Look

Finfish

Commercial finfish aquaculture began in Maine in 1970 near the midcoast town of Wiscasset. Richard Gower, Evelyn Sawyer, and Gary Towle formed *Maine Salmon Farms*, the first commercial **salmonid** pen culture operation on the east coast, and the second in the U.S. They raised rainbow trout and coho salmon in floating net pens and fed them a homemade concoction of shrimp and herring waste from a local fish meal plant. High water temperatures during the summer and low water temperatures during the winter were factors in the collapse of their business.

Also in the 1970s, Robert Mant started *Maine Sea Farms* on Cape Rosier. He raised coho salmon and rainbow trout in pens that floated in the flooded pit of a former 300-foot-deep, open-pit, copper and zinc mine. In another part of Penobscot Bay in 1973-74, Spencer Fuller started a Vinalhaven-based company, *Fox Island Fisheries*, which was probably the first strictly marine salmon pen operation in the Northeast. By 1975, Fuller's company was producing 40,000 pounds of fish in Hurricane Sound. The combination of the 1976 superchill, when the seawater temperature at the site dropped to 29.5°F, and the low price for fish caused the company to close by 1979.

In 1981, Edward Myers of *Abandoned Farm, Inc.* on the Damariscotta River, obtained the

first lease from the Maine Department of Marine Resources, allowing the culture of salmon and shellfish at his site. Using 5,000 coho salmon, Myers set up pens about eight miles from the open sea. That winter, water temperatures fell to 28°F. and only 150 fish survived. Myers abandoned finfish cultivation to concentrate on mussel culture.

By the early 1980s, pen-rearing techniques improved, and raising salmon and rainbow trout became a promising new business in Downeast Maine. In Eastport, where the decline of the local herring fishery made salmon aquaculture a welcomed new industry, *Ocean Products Inc. (OPI)* was established in 1982. By 1984, the company had 12 pens holding about 63,000 fish. Some of the fish were smoked and sold through L.L. Bean's mail-order catalog.

A second generation of sea farmers in the Eastport area came mostly from former employees of OPI, local families formerly involved in herring fishing, or were graduates of an aquaculture training course at Washington County Technical College. These people formed small, mostly family-run businesses in 1986-87. Their examples were soon followed by large firms, some of them **multinational**, including *Maine Coast Nordic Enterprises*, *Sea Farm Lubec*, *Atlantic Salmon Maine*, and *Mariculture Products, Ltd.*

Currently, 12 companies along the Maine coast, from the Canadian border to Muscongus Bay in the midcoast region, raise about 22 million pounds of salmon each year. Maine fish farmers and scientists are researching nutrition and feeding methods, predator controls, and alternative species of fish for culture.

Shellfish

In the 1970s, a few small oyster and mussel farms pioneered raising shellfish. The industry grew slowly, but the 1980s brought promising changes. In mussel and oyster farming, bottom culture techniques were developed to allow growers to produce their crops more efficiently. According to 1989 data, for every 1,000 acres of ocean bottom planted with oysters, about \$35 million worth of shellfish could be harvested each year. Also in the 1980s, the *Beals Island Regional Shellfish Hatchery* began to spawn soft-shell clams and educate clam diggers and the public about the life cycle of clams and ways to restock depleted clam flats.

Sea Vegetables

Aquaculturists in the 1990s began to investigate the culture of *nori*, a species of algae native to the Pacific and most familiar as the seaweed wrappers for sushi, Japanese delicacies made of raw fish, vegetables, and rice. In Cobscook and Penobscot bays, large nets seeded with nori were placed in areas where strong currents could provide the necessary nutrients and oxygen-carbon dioxide exchange needed by the seaweed. The harvested seaweed is sent to Eastport for processing on a press (the only one of its kind in the Western Hemisphere) that turns out paper-like sheets of dried nori, for the growing U.S. market.

ACTIVITY 2: AQUACULTURE NEWSLETTER

Information

A class newsletter provides an excellent opportunity to engage students of all abilities in a class project. The newsletter should concentrate on local events which are more relevant to the students and the community. The following could be included: personal interviews with members of the community, summaries of articles from local papers and magazines, photographs, artwork, poetry, editorials, comics, supermarket inventories of aquaculture products, recipes, web site reviews, etc. The newsletter can be an ongoing project throughout the unit. After it is completed, it can be displayed in the school or distributed throughout the local community to educate others.

Depending on the age and ability of your students and your teaching objectives, the format of the aquaculture newsletter activity can be modified to suit your needs. It could simply be a teacher compilation of student work, a sophisticated newspaper, or a magazine. Access to a personal computer would provide a good opportunity to experiment with some simple graphic design, graphing, and word processing.

Procedure

1. Introduce the idea of a class newsletter about aquaculture.
2. As a class, generate a list of various components which ought to be included in the newsletter.
3. Have students choose which areas of the newsletter they would like to be responsible for and divide the students up into groups based on their interests.
4. Have groups work on their part of the newsletter.
5. As a class, discuss the design of the newsletter and how to incorporate everyone's work into a final product.
6. Compile and merge the various components to form the class newsletter.
7. Publish and distribute the newsletter.

ACTIVITY 3: FISH MARKET AQUACULTURE SURVEY

Preparation

Locate a few local fish markets and inform them that students will be stopping by to ask them questions about their fish and shellfish products. Students may visit these fish markets individually, with their family, or as a class.

Procedure

1. Distribute and explain the student handout *Fish Market Survey*.
2. Have students discuss the purpose in conducting this survey.
3. Have students visit a local fish market. If possible, encourage students to survey different fish markets for comparison.

4. At the fish market, have the students fill out the inventory sheet so that they can distinguish between products that are coldwater, warmwater, marine, cultured or wild caught. They can also record the packaging of the product (fresh, frozen, canned, etc.) Students should also be aware of price and quality differences between cultured and wild caught fish products.

5. Share and compile students' findings in class.

Discussion

1. In what ways does aquaculture impact the economics of the fish market?
2. What influences might a producer, a retailer, or a consumer have on the market?
3. Does the fish market sample represented by the class results adequately represent fish markets in the State of Maine? How might the study be revised to improve its validity?

MAJOR AQUACULTURE FACILITIES IN MAINE

TYPE	SPECIES ¹	CULTURE ²	COMPANY	LOCATION
Shellfish	M	S,P	Abandoned Farm	South Bristol
Shellfish	O,C	B	Associated Sea Farms	Newcastle
Shellfish	M	B	Beal, Isaac	Beals
Shellfish	C	F	Beals Is. Reg. Shellfish Hatchery	Beals
Shellfish	M,O,C,Sc	F,B	Chance Along Farm	Freeport
Shellfish	O	S	Dodge Cove Marine Farms	Damariscotta
Shellfish	C	B	Federal Harbor Farms	Lubec
Shellfish	O	S	Glidden Point Oyster Co.	Newcastle, S. Bristol
Shellfish	M	B,S	Great Eastern Mussel Farms	Jonesport, Deer Isle, Lamoine
Shellfish	O	F,B	Hog Island Shellfish Inc.	Newcastle
Shellfish	O,C	B,S	Marine Bioservices Co.	Damariscotta
Shellfish	O,C,Sc	F,B	Mook Sea Farms, Inc.	Newcastle
Shellfish	O	B	Pemaquid Oyster Co.	Damariscotta, Newcastle
Shellfish	O,C	B	Spinney Creek Shellfish	Eliot
Shellfish	M	S,B	Thompson, Paul	Cutler
Shellfish	O	B	York Harbor Oyster	York
Finfish	S	S,P	Atlantic Aquafarms	Sorrento, Eastport
Finfish	S	P	Atlantic Salmon of Maine	Machiasport, Cutler, Harrington
Finfish	S	P	Birch Point Fisheries	Perry
Finfish	S	P	Connors Aquaculture, Inc.	Lubec, Eastport
Finfish	S	P	Cooke Aquaculture U.S., Inc.	Lubec, Eastport
Finfish	S	T	Craig Brook National Fish Hatchery	E. Orland
Finfish	S	P	D.E. Salmon Company	Lubec
Finfish	S	P	East Coast Fish Farms	Lubec, Pembroke
Finfish	S	P	Friendship Fisheries, Inc.	Eastport
Finfish	S	T	Green Lake National Fish Hatchery	Ellsworth
Finfish	S	P	Hydro Sea Foods	Brooklin
Finfish	A	T	Integrated Food Technologies	Franklin
Finfish	S	P	Island Aquaculture Corp.	Swans Island, Frenchboro
Finfish	S	P	Island Salmon, Inc.	Perry
Finfish	S	P	Maine Aqua Foods, Inc.	Eastport
Finfish	S	P	Maine Coast Nordic	Jonesport, Cutler
Finfish	S	P	Maine Pride Salmon	Eastport
Finfish	S	P,S	Maine Salmon, Inc.	Eastport
Finfish	S	P	North Atlantic Aquaculture, Ltd.	Eastport
Finfish	S	P	Sheep Cove Associates	Perry

TYPE	SPECIES ¹	CULTURE ²	COMPANY	LOCATION
Finfish	S	P	Skybird Unlimited	Lubec
Finfish	S	P	Stolt Seafarm Maine, Inc.	Lubec
Finfish	S	P,S	Treats Island Fisheries, Inc.	Lubec, Eastport
Finfish	S	P	Trumpet Island Salmon Farm, Inc.	Tremont
Seaveg	N	S	Coastal Plantations	Lubec, Eastport
Fresh	S,T	T	Casco Fish Hatchery	Casco
Fresh	T	T	Dry Mills Fish Rearing Station	Gray
Fresh	T	T	Embden Fish Hatchery	N. Anson
Fresh	S,T	T	Enfield Fish Hatchery	Enfield
Fresh	T	T	Governor Mill Fish Hatchery	Augusta
Fresh	S	T	Grand Lake Stream Fish Hatchery	Grand Lake Stream
Fresh	T	T	Mineral Springs Trout Ponds	E. Vassalboro
Fresh	T	T	New Gloucester Fish Hatchery	New Gloucester
Fresh	T	T	Palermo Fish Rearing Station	Palermo
Fresh	T	T	Phillips Fish Hatchery	Phillips
Fresh	T	T	Sea Run Holdings	Kennebunkport
Fresh	T	T	Pine Tree Trout Hatchery	Sanford
Fresh	T	T	Shy Beaver Hatchery	W. Buxton

¹ M - mussel	O - oyster	C - clam	S - salmon	T - trout	A - arctic char	N - nori
² B - bottom	F - floating	S - suspended	P - pen	T - tank		

This chart was compiled by the project's curriculum consultants from data provided by the Maine Department of Marine Resources, Maine Aquaculture Innovation Center, extension agents, and industry contacts.

To Culture or Not to Culture: The Controversy Continues

KEY CONCEPTS

Aquaculture, like any other industry, has its costs and benefits, as well as its proponents and opponents. As a result, there are impediments to aquaculture development in Maine. Some of the concerns expressed about aquaculture are valid, while others are steeped in misconceptions and misunderstandings about the nature of aquaculture in Maine. An active, involved, and informed community is needed to determine whether or not aquaculture is suitable for their community and coastal waters. Comprehensive federal and state regulations are necessary to insure that an aquaculture venture does not compromise the integrity of the community and the natural environment.

LESSON OVERVIEW

Students will discuss some of the pros and cons related to aquaculture. As a class, the students will discuss the hypothetical case studies provided. In cooperative learning groups, students will engage in an aquaculture debate in the style of a town meeting.

LEARNING OBJECTIVES

After completing this chapter, the student will be able to:

- Describe the impediments to aquaculture development in Maine.
- Describe the pros and cons of an aquaculture industry in their community.
- Describe the position of several community groups regarding aquaculture development.
- Work cooperatively in groups to solve real life problems.
- Adopt a position and defend it effectively.
- Demonstrate critical thinking skills.
- Demonstrate public speaking skills.

LEARNING RESULTS

AQUACULTURE DEBATE/TOWN MEETING

- B. Ecology:** Students will understand how living things depend on one another and on non-living aspects of the environment.
4. Analyze the impact of human and non-human activities on the type and pace of change in ecosystems.
- K. Scientific Reasoning:** Students will learn to formulate and justify ideas and to make informed decisions.
1. Judge the accuracy of alternative explanations by identifying the evidence necessary to support them.
 2. Show that agreement among people does not make an argument valid.
 5. Produce inductive and deductive argument to support conjecture.
 7. Analyze situations where more than one logical conclusion can be drawn.
- L. Communication:** Students will communicate effectively in science and technology.
8. Debate opposing points of view using a common set of information.
- M. Implications of Science and Technology:** Students will understand the historic, social, economic, environmental, and ethical implications related to science and technology.
3. Evaluate the ethical use or introduction of new scientific or technological developments.

MATERIALS

Copies of student handout *To Culture or Not to Culture*, overhead *Aquaculture: Arguments For and Against*, overhead projector.

BACKGROUND

Why does the U.S. lag behind so many other nations in aquaculture production?

Even though national policy is aimed at encouraging aquaculture initiatives, there are still many barriers to starting new aquaculture ventures including:

• Economics

Starting a new aquaculture venture is expensive, it requires a large initial capital investment, and it may be quite some time before entrepreneurs begin to see a profit. Banks may be skeptical about loaning out large sums of money to small aquaculture entrepreneurs. As a result, new aquaculture enterprises often favor large businesses over smaller, community operations.

• Environmental issues

Not every body of water can serve as a site for an aquaculture facility. There are very specific requirements which must be met. For example, to raise freshwater trout, you must have a continuous supply of very cold water. For salmon, or other maricultured finfish, you must have very strong tides to disperse the waste produced from the finfish or you risk polluting the surrounding waters. For mollusks, you must have nutrient-rich water. Culturing shellfish and sea vegetables rarely have any negative environmental consequences.

Mariculture operations are always at the mercy of mother nature. Storms and other oceanographic and meteorological conditions can wreak havoc on one's culturing operation. A specific threat to maricultured shellfish is a tiny organism called fecal coliform bacteria which can enter the water via sewage, particularly during times of flooding. In spite of all these hazards, Maine has an excellent marine environment for raising maricultured fish, shellfish, and algae because of its high tides, strong currents, and nutrient-rich water.

• Opposition

Probably the biggest barrier to starting new aquaculture ventures is local public opposition. Although there are many people who support and encourage a growing aquaculture industry, there are others who oppose such growth.

In 1990, the Maine Coastal Program at the State Planning Office published An Aquaculture Development Strategy for the State of Maine which listed several impediments to aquaculture development in Maine:

1. Lack of information about aquaculture development such as production technology.
2. Lack of a lead state agency to coordinate action and state services to provide programs in training, inspection, and grading (sorting fish by size).
3. Lack of research and development coordination between federal, state and university research organizations.
4. Lack of public understanding about the nature of aquaculture, specifically that success of aquaculture ventures depends on good environmental quality in Maine's coastal waters.
5. Lack of adequate organized market institutions for sale of cultured seafood.
6. Lack of incentive for small, local business investments in aquaculture.

In response to these impediments, a strategy was developed which was designed to reduce or remove the impediments listed above. The strategy included the following goals:

1. Develop and disseminate information about aquaculture.
2. Cultivate a positive investment climate for small entrepreneurs.
3. Designate a lead state agency to support development of aquaculture.
4. Develop a comprehensive regulatory process.
5. Include traditional fisheries.
6. Protect, preserve, and enhance coastal water quality.
7. Develop a comprehensive plan for use of coastal waters.

Since 1990, state officials have been working to achieve the above goals and encourage the growth and development of aquaculture in Maine. Many Maine organizations have helped realize this goal such as: Maine Department of Marine Resources, Maine Aquaculture Innovation Center, Sea Grant College Program, and the University of Maine system.

Economic issues include:

- Regulatory/permitting costs
- Capital costs
- Operating costs
- Marketing factors
- Foreign competition and trade

To be economically successful, feed and feeding practices must be cost-effective to yield more growth with minimal pollution impacts. An aquaculture operation must maintain a clean environment if it is to survive.

Environmental Issues include:

- Waste from cages or ponds
- Introduction of non-native species and/or disease
- Culture operation infrastructure in public waters
- Genetic alteration of wild stocks through escapement of cultured animals or intentional releases for stock enhancement
- Dealing with fish predators which are protected by law such as seals and eagles

Benefits of a healthy U.S. marine aquaculture industry include:

- Healthy food to replace diminishing wild stocks
- Export crop to decrease trade deficit
- Enhancement of commercial and recreational fisheries
- Economic opportunities for rural communities
- New jobs for skilled workers

ACTIVITY 1: AQUACULTURE DEBATE/TOWN MEETING

Preparation

Prior to class, have the students read the hypothetical case study about the two island communities.

Procedure

1. As a class, or in cooperative learning groups, develop a possible pros and cons list for aquaculture or use the overhead provided.
2. Give the students a chance to review the student handout *To Culture or Not to Culture* describing the hypothetical case study of Gull and Tern Islands. Engage the class in a discussion about the case study. How and why did each community reach such different conclusions about the issue of salmon farming?
3. Introduce the idea of a town meeting or debate in which various members of the community come together to reach a consensus on an issue or proposal which will affect their community. Explain that the class will conduct their own town meeting to decide whether to permit the establishment of an aquaculture venture in their community.
4. The class must first set the parameters of the aquaculture site that is being proposed:
 - Will the company be culturing finfish, shellfish, or sea vegetables? What species?
 - Will the site be warmwater, coldwater, or marine? A river, estuary, shorefront, or deepwater?
 - Is the area already used by others? By whom?
5. In the aquaculture debate, groups of students will adopt a position on aquaculture (role-playing) and defend it in a town meeting. Possible roles include: fisherman, lobsterman, coastal homeowner, vacationer, local/state politician, small aquaculture entrepreneur (local), large aquaculture entrepreneur (international), or conservation group. Before the debate, stress the professionalism and decorum which ought to take place in a town meeting. Establish a set of guidelines based on mutual respect so that the debate does not degenerate into a shouting match. Positions can include stipulations such as: "I support aquaculture in the community if x,y and z are included." You may need to stress that the point of a debate is to adopt the position of the group and defend that position. The position may or may not reflect the students' own opinions. Therefore, students ought not to feel personally attacked and have the advantage of learning how to argue positions other than their own. Students should gain an understanding of the complexity of community issues.
6. Break the class up into as many groups as there are roles. Assign (or let the groups choose for themselves) a different role for each cooperative learning group. You may want to provide a "blurb" describing each group's general position on aquaculture. However, be careful not to pigeonhole groups into black and white categories. There can be advantages to letting the students struggle with defining the roles of these groups themselves, rather than providing them with a predetermined "script." Encourage groups to approach this as a real-life scenario.

7. Give students some time to prepare their case. Each group will be given 2-3 minutes to present their case. After all groups have spoken, any group is entitled to "counter" or challenge another group's argument. It is important that the group that is challenging another group be given a time limit and that the group being challenged has the opportunity to respond to that challenge. Stick to *one* challenge and response per group.
8. After the debate is over, individuals will be asked to vote on whether or not they want to start an aquaculture venture in their community and any stipulations. Write the final decision on the board or overhead and then list the reasons and/or stipulations for the decision.

Discussion

What would you do to encourage aquaculture if you were on a special governor's committee?

OVERHEAD

Aquaculture: Arguments For and Against

FOR

Aquaculture . . .

1. Can increase employment in your community.
2. Can increase revenue in your community, resulting in better schools, parks, community programs, etc.
3. Can increase state and national revenue.
4. Can reduce the seafood trade deficit.
5. Can restore depleted native fish populations.
6. Can feed a growing population.
7. Can encourage local investment.
8. Can increase scientific knowledge and technology.
9. Can place more emphasis on protecting coastal waters from pollution.

AGAINST

Aquaculture . . .

1. Can occupy bottom formerly utilized by lobstermen and fishermen.
2. Can compromise the aesthetic beauty of our coastline.
3. Can alter the benthic (bottom) communities under coastal finfish pens.
4. Can add excess nutrients (fish feed and wastes) to coastal waters.
5. Can add chemicals and antibiotics to coastal waters.
6. Can be too expensive for small local companies because of large start-up costs.
7. Can compromise native gene pools if cultivated and native species interbreed.
8. Can threaten the livelihood of fishermen and lobstermen.
9. Can be an unpredictable enterprise for small local communities due to its susceptibility to severe weather, predators, disease, and global competition.

STUDENT HANDOUT

To Culture or Not to Culture . . . That Is the Question

Two island communities in Maine were approached by salmon farming entrepreneurs. One community said yes the other said no. Why?

In the late 1980s, both Gull Island and Tern Island were approached by separate companies wishing to establish net-pen salmon farming operations off their islands. The majority of the year-round residents on Gull Island and Tern Island make their living lobstering. While the residents of Tern Island fiercely rejected the proposal for net pen salmon farming off their island, the residents of Gull Island grappled with the proposal for some time and eventually decided to accept it and try salmon farming, hoping to supplement their traditional fishing income. What prompted these two similar communities to have such different responses to salmon farming in their coastal waters? Let's take a look at these two different approaches.

Tern Island

In 1987, a representative from Salmon Servers Inc. submitted a proposal for a 10-year lease of 25 acres of ocean bottom off Tern Island. The residents of Tern Island were first introduced to the proposal at a public hearing. No attempt was made to introduce the idea to Tern Island's residents prior to the hearing, and the people of Tern Island were not pleased about being left in the dark.

The proposed 25-acre lease area was prime lobster and scallop area, used heavily by the lobstermen and fishermen of the island. The fishing community was concerned about not having access to those 25 acres and also about the effect the net pens would have on the surrounding bottom. They feared contamination of the bottom and the surrounding coastal water from fish food and waste, antibiotics used in the pens, chemicals used in the fish foods, and diseases spread by the cultured salmon. Another fear was that escaped salmon could mix with wild salmon and negatively affect the local native salmon species. Many of these fears were valid, while others were not. Many of the contamination issues which had been problems in past net-pen ventures in Norway and Sweden, had since been resolved.

The effect of aquaculture on the local economy was another issue for the residents of Tern Island. While Salmon Servers Inc. promised economic gain, residents feared that the big corporation would bring workers from off-island. Residents researched the job total and determined that there would be only three to five jobs available per farm which might not make up for the money lost from the 25 acres of bottom leased to Salmon Servers Inc.

Another issue was tourism. Tourists and summer residents alike are attracted by the beauty of the island. In the summer, the size of the island swells from 1,200 to 6,000. Islanders feared the salmon pens would be an eyesore which would compromise the natural beauty of the island, deter tourists, and reduce the property value of their homes. Due to community opposition, Salmon Servers Inc. withdrew its proposal.

Gull Island

Soon after the Tern Island aquaculture fiasco, Gull Island was approached with a different salmon culturing proposition. Initially, a representative of Salmon Lovers Ltd. came to the island to speak with members of the Gull Island Fisherman's Coop. Members of the community were invited to several informative discussions to decide whether they were interested in exploring salmon

farming as an option. Although there was a great deal of negative aquaculture propaganda floating around the community, there was little in the way of concrete information. Keeping an open mind, the Gull Island Fisherman's Coop thoroughly researched salmon farming, and visited salmon farms in New Brunswick.

Many of the salmon farms that Gull Island residents visited were small operations run by former and current fishermen and lobstermen. Because of the strong tidal action in the Gulf of Maine, there was no buildup of feed or waste under the pens, and scallop and lobster populations in and around the pens were healthy. The two antibiotics which were used in the salmon pens were both approved by the U.S. Food and Drug Administration (FDA) and were commonly used in lobster pounds. The contamination problems such as those experienced in Norway had resulted from overcrowding, shallow sea pens, and inadequate tidal current. These problems were remedied once the sea pens were moved from the still water fjords to the open oceans. Salmon farmers frequently commented that if the net-pen salmon were to contaminate the surrounding water or bottom in any way, the salmon themselves would be the first ones to suffer.

Although the Gull Island fishing community was sufficiently convinced about the merits of aquaculture to continue exploring salmon farming as an option, there was still opposition from members of the community. Some residents were concerned about the potential environmental problems associated with aquaculture. Other members were concerned with the aesthetic value of their coastline and the affect that salmon farms could have on the property value of their homes. Much of the opposition came from summer residents and tourists.

Ultimately, there was greater support for salmon farming than there was opposition to it. Salmon Lovers Ltd. offered to help set up any member of the community who wanted to get involved in salmon farming, so a mutually beneficial partnership was established. Gull Island began salmon farming very conservatively, with seven, well-spaced pens on 18 acres. They purposefully understocked the pens to avoid problems associated with overcrowding. As a result of their caution, no antibiotics were necessary and the salmon and the surrounding bottom community were healthy.

GLOSSARY

Antibiotic: A chemical compound which can inhibit reproduction or cause the destruction of bacteria.

Benthic: Bottom-dwelling organisms in an ocean community.

Compromise: An agreement between two parties in which each side makes concessions.

Contamination: Polluted or impurity caused by contact with another substance.

Deficit: The quantity by which an amount is less than the needed amount.

Entrepreneur: A person who takes on the risk of a business venture hoping to profit.

Fecal Coliform Bacteria: A rod-shaped microorganism found in the solid waste of humans and some other animals. These bacteria render water supplies unusable.

Investment: The money put into a business.

Pelagic: Organisms living in ocean waters away from the shore or bottom.

Public Hearing: A meeting to discuss or resolve an issue. The general population is invited.

Net-pen Salmon Farming: An aquaculture technique using nets to form holding pens for salmon.

MAKING CONNECTIONS: ADDITIONAL ACTIVITIES AND EXTENSIONS

- Survey/Questionnaire

Have students create a survey/questionnaire to determine how members of the community would feel (or do feel) about having an aquaculture facility in their community. Have them survey family, friends, and members of the community and share their results with the class. Students may also choose to tape a personal interview with someone who has an interesting point of view.

- Marine Issues

Divide students into groups and have each group monitor one local marine issue or controversy involving fisheries and/or aquaculture.

ADDITIONAL RESOURCES

Maine State Planning Office. *An Aquaculture Development Strategy for the State of Maine*. Augusta: Maine Coastal Program, 1990.

Mook, William. "Aquaculture: A Boost for Maine's Fisheries." *Coastal Choices: Deciding Our Future*. Augusta: Maine Coastal Program, n.d.

Griffin, Nancy. "A Tale of Two Islands." *National Fisherman* 70(12): 20; 1990.

Aquaculture: What's Involved

KEY CONCEPTS

There are several steps that one must take when starting an aquaculture venture: choosing an appropriate species to culture; obtaining a bottom lease and permit; designing, building, and maintaining the aquaculture facility; obtaining, breeding, and maintaining the health and nutrition of the species being cultured; and harvesting, processing and marketing. The multifaceted nature of aquaculture demands a diversity of skills including scientific, mechanical, technological and business.

LESSON OVERVIEW

Students will discuss the various stages involved in starting an aquaculture venture. In the form of a jigsaw, groups of students will choose a species to culture and identify the processes involved in culturing that species. Groups will generate a list of all the jobs/careers related to their form of aquaculture. Groups will engage in a hands-on activity which simulates a method aquaculturists use for estimating numbers of fish, based on weight.

LEARNING OBJECTIVES

After completing this chapter, the student will be able to:

- List the steps involved in starting an aquaculture venture.
- List the various skills and jobs needed in aquaculture.
- Determine which species are best suited for aquaculture in their area.
- Work cooperatively to make decisions.
- Demonstrate critical thinking and individual initiative.
- Demonstrate creative writing skills.
- Demonstrate technical writing skills.
- Demonstrate research skills.
- Demonstrate mathematical problem-solving ability.
- Apply computational skills involving algebra and geometry.

LEARNING RESULTS

STARTING YOUR OWN AQUACULTURE OPERATION

- B. Ecology:** Students will understand how living things depend on one another and on non-living aspects of the environment.
4. Analyze the impact of human and non-human activities on the type and pace of change in ecosystems.
- L. Communication:** Students will communicate effectively in science and technology.
2. Use journals and self assessment to describe and analyze scientific and technological experiences and to reflect on problem solving processes.
 5. Critique models, stating how they do and do not effectively represent the real phenomenon.
- M. Implications of Science and Technology:** Students will understand the historic, social, economic, environmental, and ethical implications related to science and technology.
1. Explain the impact of political decisions on science and technology.
 2. Demonstrate the importance of resource management, controlling environmental impacts, and maintaining natural ecosystems.

DETERMINING NUMBER BY WEIGHT IN FISH POPULATIONS

J. Inquiry and Problem Solving: Students will apply inquiry and problem solving approaches in science and technology.

1. Make accurate observations using appropriate tools and units of measure.
2. Verify, evaluate, and use results in a purposeful way.

L. Communication:

3. Make and use appropriate symbols, pictures, diagrams, scale drawings, and models to represent and simplify real-life situations and solve problems.
5. Critiques models, stating how they do and do not effectively represent the real phenomenon.

MATERIALS

Copies of lab handout *Determining Number by Weight in Fish Populations*, 1-quart glass jar filled with dry kidney beans for each lab group, one 8-inch diameter aluminum pie tin for each lab group, scales, calculator (optional).

BACKGROUND

Starting an aquaculture operation is no simple task. A great deal of research is necessary to determine which species to culture and what technology to utilize. A variety of skilled professionals will be needed in order to design, build, and maintain the facility. Aquaculture is a business and therefore requires all the skills associated with running a business, including financial management, human relations, and bookkeeping—as well as an understanding of the legal aspects of licensing and permitting the facility. Both the business aspect of aquaculture and the day-to-day management requires mathematical problem-solving and computational skills.

There are so many different skills required in the growing industry of aquaculture. As a result, there are many different jobs and careers related to aquaculture, both directly and indirectly. Education and training for careers in aquaculture may take place at technical or vocational schools, colleges and universities, internships and on-the-job training,

Jobs in Aquaculture

Supplies and Services

- **Finance:** Providing money for establishing aquaculture facilities.
(banker, loan officer, farm credit association employee)
- **Feed and Supplies:** Manufacturing, selling, hauling, storing, purchasing feed and feed ingredients.
(feed salesperson, truck driver, feed mill workers, nutritionist)
- **Equipment:** Manufacturing, selling, hauling and installing aquaculture equipment.
(equipment engineer, builder, installer, salesperson)
- **Construction:** Designing and constructing aquaculture facility.
(engineer, architect, carpenter, equipment operator, electrician, surveyor, well driller)
- **Consulting:** Advising aquaculturists on how to manage a successful aquaculture business.
(general consultant, extension specialist, veterinarian, nutritionist)

Training and Education: Includes an increasing number of jobs available in the area of educating and training the next generation of aquaculturists.

- High school instructor
- College or university instructor

- Fisheries instructor
- Extension specialist

Production Employment: Includes all occupations directly associated with growth, reproduction, and harvesting of the cultured species.

- Business management: Encompasses planning, organizing, staffing, directing, and controlling the activities at the aquaculture facility.
- Aquaculture staff: Includes both skilled and unskilled laborers. (fishery technician, water technician, seine operator, biologist)

Marketing: Includes all jobs and activities which link the aquacultured product to the consumer.

- Processing: Usually involves the preparation of fish or shellfish in a processing plant.
- Promoting/ Marketing: Encourages the consumer to purchase the product.° (writers, photographers, advertisers, and salespeople)

Inspection: Includes jobs related to health, safety, and environmental regulation.

Research and Development: Includes research scientists, technicians, and lab assistants who continually look for new and profitable ways to culture species.

General Marine Farm Site Requirements for Atlantic Salmon

(Submitted by Christopher Bartlett, Sea Grant Marine Advisory Program, University of Maine)

- *Temperature:* 0° - 20° C (32° - 68° F)

(Note: -0.7° C is lethal to fish, i.e. they die from "superchill.")

- *Depth:* Flexible depending on containment system; average rule of thumb is a minimum of 3 meters (10 feet) between net bottom and ocean floor. Most salmon farms in Maine are situated in at least 40 feet of water at mean low tide.

- *Protection:* Open ocean conditions are capable of exerting very high energies during the winter storm months, which can severely damage the floating cage systems. Therefore, most salmon farms are situated in areas sheltered from the prevailing winter winds. Look on the charts and see the islands and bays that are used for protection by Maine's salmon farms.

- *Oxygen:* Oxygen is required both for the biological needs of the salmon and the biological needs of the environment to process the organic loading caused from the deposit of feces and excess feed. Salmon require 7 to 12 parts per million (milligrams oxygen per liter of seawater.) The benthic community requires 75% to 85% saturation for aerobic breakdown of carbon.

- *Current:* Current, which transmits oxygen to the fish and the benthos, is a very important factor in locating sites. Most of Maine's salmon farms have a peak of 25 to 40 centimeters per second (cm/sec) current at the surface which supplies an ample amount of oxygen. This means that the average current velocity throughout a tide cycle would be about 10 cm/sec. (Remember that there are periods of slack tide in between the coming and going cycles.) 25 cm/sec on the bottom is considered to have erosional force, and some farms in the state are subjected to this amount of current. Current

is a direct function of tide, so the greater the tide height, the greater the current. Constrictions in bays where the water is forced through a narrow channel also greatly increase the current speed.

ACTIVITY 1: STARTING YOUR OWN AQUACULTURE OPERATION

Procedure

1. As a class, brainstorm a list of the steps one must take when starting an aquaculture operation.
2. Divide the class into cooperative learning groups with four people per group. Explain that each *group* will devise a detailed proposal for beginning an aquaculture operation. Each *member* of the group will become an "expert" in a particular area and then share his/her expertise with their group. The areas to choose from are: 1) Business and Legal Issues 2) Facility Siting and Construction 3) Management and Maintenance, and 4) Processing and Marketing. Members from each group will choose one of the four areas in which to gain expertise.
3. Distribute the handout *Choosing an Aquatic Species for Culture* to each student. Have each group choose a species to culture based on the guidelines.
4. Members from each group will choose an expert role and look over their particular *Area of Expertise* sheet.
5. Convene a "conference of experts" for each area to discuss the general needs of their area of responsibility. (Students will leave their original group to meet with students in other groups who share their area of expertise.)
6. Experts will return to their original groups and contribute their expertise to develop a plan for their new aquaculture company and the species they will culture.
7. After each group has developed a comprehensive development strategy, it will generate a list of jobs related, either directly or indirectly, to its aquaculture venture.
8. Each group presents their aquaculture proposal to the class, which then comments on the feasibility of the operation.
9. As a class, generate a master list on the board, or on butcher block paper, of all the jobs related, either directly or indirectly, to aquaculture.

Discussion

1. Were the students, individually and/or collectively, able to effectively carry out the simulation?
 - What additional research might need to be done?
 - What experts might need to be called in?
2. How effectively does this simulation represent the actual establishment of an aquaculture operation?

STUDENT HANDOUT

Choosing an Aquatic Species for Culture

What type of aquaculture will you choose?

Out of the thousands of aquatic species, how does an aquaculturist decide which species to culture?

- **Warmwater, coldwater, or marine?**

One of the first decisions is whether to culture a warmwater, coldwater, or marine species. The answer, in part, is decided by the region in which you choose to start your aquaculture facility. It makes sense to culture a coldwater fish like freshwater trout in cool northern waters or in locations where there are cold springs. A warmwater fish like catfish is best cultured in the south. If you are looking to set up an aquaculture facility on the coast, you will be looking at saltwater species for mariculture.

- **Finfish, shellfish, or aquatic plants?**

Once again, deciding whether to culture finfish, shellfish, or aquatic plants has a lot to do with your location. Because Maine has protected bays with generally clean and nutrient-rich waters with large tides, the entire coast is suitable for aquaculture in one form or another. The greatest concentration of *finfish* operations is in Downeast Maine where winter water temperatures tend to be higher. Most *shellfish* farms are in the midcoast region. Maine's lakes, with their abundance of clean water, are also ideal places for freshwater finfish hatcheries.

Which species will you culture?

Once you have decided on a particular *type* of aquaculture which is best suited to your region, community, and individual goals, the next question is which *species* to culture. Aquaculturists want to choose a species which:

- Has been successfully cultured before.
- Has a good, stable market value.
- Is well understood in terms of its biology, ecology, reproduction, and susceptibility to disease.

(Note: This is not to say that new or developmental species should not be cultured. Experience has shown that, the more we diversify our aquaculture market, the better. Or, as the saying goes: Don't put all your eggs in one basket. For example, if Maine only raises salmon, and a disease wipes out a large portion of the cultured salmon, or the market price drops, then Maine's aquaculture industry could be in big trouble. Therefore, it is very important for scientists and aquaculturists from universities and research facilities to continue experimenting with a wide variety of species for us to culture.)

How large do you want your operation to be?

Finfish operations such as salmon farms tend to be larger operations than shellfish operations. Larger operations may result in larger profits; however, they also require larger financial investments, more labor, and more risk. Another related question is whether you want to work for a large aquaculture corporation or start a small community aquaculture facility on your own.

Areas of Expertise

1. Business and Legal Issues

Licensing and Permitting

Aquaculture entrepreneurs must submit an aquaculture application and fee to the Maine Department of Marine Resources (DMR) if they wish to lease areas on and under coastal water for scientific research or for aquaculture of marine organisms. DMR then conducts an environmental review of the proposed lease site, including an assessment of possible conflicts with wildlife. Lease applicants must show that they have the technical capabilities and financial capacity to operate and maintain their proposed facility. Once the lease is granted, DMR establishes annual lease fees. Aquaculture sites must also be approved by the state Department of Environmental Protection and often by the U.S. Army Corps of Engineers. Once an application is approved, a public hearing is held during which all interested parties convene to discuss the proposal.

The Business of Aquaculture

Many business skills are needed in aquaculture such as:

- Record/bookkeeping
- Loan applications
- Hiring and managing employees
- Financial management
- Public relations

2. Facility Siting and Construction

Designing and Building the Grow-out Facility

After obtaining juveniles, the next step is choosing the best site for your grow-out facility. Engineers, architects, contractors, builders, and inspectors will be needed to design and build the aquaculture facility. Depending on which species you choose, you may need very little equipment or you may need a great deal of expensive, high tech equipment.

- *Finfish* culturing will require ponds or net pens to grow out the fish, as well as specialized nets (seines) to harvest the crop and a processing facility to dehead, gut, and clean the fish.
- *Shellfish* culturing may require very little in the way of technology if species are cultured in their natural environment. Clams are often cultured in trays and mussels on ropes. In an artificial environment, you will need a flowing seawater lab with trays to rear the young, tubs to spawn the broodstock, and tanks to raise algae to feed your shellfish. Most shellfish are marketed in their shells, often after they have been cleaned. Increasingly, growers are seeking new processed product forms.
- *Sea Vegetables*, such as nori, require little more than trays in the water seeded with spores, but a special machine is needed to convert the algae slurry into flat, uniform sheets which are the saleable end product.

3. Management and Maintenance

Getting Started

Once your aquaculture setup is in place and ready to go, you ought to have your staff in place as well. Full and part-time employees may include consultants, biologists, chemists, laborers, and veterinarians. Now you are ready to transport the seed, broodstock, and juveniles, and begin culturing your species of choice.

Health Management

The aquaculture facility must be maintained and managed. This includes water quality management and equipment maintenance. Biologists need to maintain the health of the species being cultured which includes management of:

Feeding and Nutrition: This involves what to feed and how much (if applicable).

Stress: Fish can be stressed by overcrowding, lack of oxygen, and other factors.

Disease: Disease often results from stress and can many times be prevented by carefully monitoring the aquatic environment and feed. If not, chemicals and antibiotics can provide temporary relief, but the underlying cause of the stress must be remedied in order to alleviate the problem. Vaccines can be effective for certain viral and bacterial diseases.

Reproduction: This may involve managing broodstock, spawning, genetic selection, incubation, growth, and development.

4. Processing and Marketing

How will your aquaculture product be harvested, processed and marketed?

Harvesting, processing and marketing the aquaculture crop differs greatly depending on which species is being raised.

- Harvesting involves gathering or capturing product for processing and marketing and may include topping (partial harvest) or total harvest.
- Processing involves many steps to prepare product for consumption and may include gutting, deheading, cleaning, filleting, smoking, marinating, or other preparations
- Marketing involves selling the product to the consumer and may include grading (sizing), packaging, advertising, wholesaling, and retailing.

ACTIVITY 2: DETERMINING NUMBER BY WEIGHT IN FISH POPULATIONS

Hand out copies of the following activity to each student. The activity can be modified to be more or less challenging, depending on your group.

Information

Aquaculturists need to employ hands-on mathematical skills on a daily basis. Fish and shellfish need to be measured, weighed, and counted; feed type and quantities determined; water samples measured, tested, and analyzed; and chemicals and antibiotics measured, mixed, and distributed.

In finfish aquaculture, fish need to be counted and weighed for many purposes such as taking inventory, determining growth weights and feed quantities, and for fish sales. Often it is impossible, or at least impractical, to count each individual fish. For example, fingerlings (1 to 2-inch fish), are often sold by the thousands or hundreds of thousands.

Aquaculturists must employ sampling methods which allow them to estimate the number of fish based on their weight. A sample (small part) of the entire population (all the fish in the enclosure) is netted and counted into a bucket suspended from a spring tension scale. After weighing a number of these samples, an average weight can be determined. Assuming that all fish are graded evenly (approximately the same size), you can simply use weight to determine large quantities of fish.

Sampling Methods:

Mathematical problem-solving is necessary to determine precise estimates of fish numbers. The following formula is used:

$$\frac{\text{Sample Number}}{\text{Sample Weight}} = \frac{\text{Total Number}}{\text{Total Weight}}$$

As long as three out of the four variables are known, the fourth variable can be determined using cross multiplication.

A hypothetical example:

1. Joe and Sue are salmon farmers. They have kept excellent records and they know that there are 6,357 salmon in their net pen. They need to know how much these 6,357 salmon weigh in order to determine the proper amount and kind of feed they should be giving the salmon at this particular life stage. They net, weigh, and count out 50 fish from four separate sample sites within the pen and come up with 9.5 pounds (lbs.), 10.2 lbs., 10.5 lbs. and 9.8 lbs. When they average the four samples, they come up with an average sample weight of 10.0 lbs. Since they now know three of the four variables, they simply need to cross multiply to determine the total weight of all the fish in the pen.

$$\frac{50 \text{ fish}}{10 \text{ lbs.}} = \frac{6,357 \text{ fish}}{X} \quad (50)(X) = 63,570 \quad X(\text{total wt. of fish}) = 1,271 \text{ lbs.}$$

2. It is useful to utilize this same procedure in other situations as well. For example, if Joe and Sue made a sale that day of 2,500 fish, it would be much easier to weigh out the fish rather than try to count them. By counting and weighing out a smaller sample, they can figure out the weight of the 2,500 fish.

$$\begin{array}{rcl} 50 \text{ fish (sample number)} & & 2,500 \text{ fish (total sale number)} \\ \hline & = & \hline 10 \text{ lbs. (sample weight)} & & X \text{ lbs. (total sale weight)} \end{array}$$

Now, solve for the unknown variable, X (the total weight of the fish):

$$(50)(X) = 25,000$$

$$X = 500 \text{ lbs}$$

The 2,500 fish would weigh 500 lbs.

Procedure

1. In this simulation, kidney beans represent fish. The glass jar filled with kidney beans represents your entire stock of fish. The pie tin represents a one-acre pond which you will have to stock with the appropriate number of fish.
2. Count out 50 beans from the jar and weigh them. Now you know the sample number and sample weight. These numbers can be used to determine the weight or number of larger population of the same fish.
3. Now, imagine that you are selling some of the fish to another aquaculturist who will grow the fish to market size. Let's say that a proper stocking rate is 200 fish per acre. The 8-inch diameter pie tin represents the grow-out facility pond which you are stocking with a sample of your fish. Let's assume that 25 inches squared is equal to one acre. How many acres does the pie tin represent? You must use the formula for the area of a circle $a = \pi r^2$ to determine the area of the pie tin (grow-out pond). The area of the pie tin turns out to be approximately 50 inches squared. Since one acre is equal to 25 inches squared, then the pie tin represents a two-acre, grow-out pond. If you are supposed to stock the grow-out pond at a rate of 200 fish per acre, you will need 400 fish total. Therefore, the only variable which is still unknown is the weight of the sample.
4. Now determine the weight of your sale population of 400 fish, by substituting in your three known variables and solving for X (the total sale weight) in the following equation:

$$\begin{array}{rcl} \text{sample number} & & \text{total sale number} \\ \hline & = & \hline \text{sample weight} & & X \text{ (total sale weight)} \end{array}$$

5. Weigh out the amount of beans from the answer above to represent the sample of fish from your population that you will be selling, and place it in the pie tin.

Discussion

1. Do you think that estimating numbers by weight is an accurate measure. Why? Why not?
2. Why would this method be ineffective if your fish population had mixed age classes?
3. Can you think of other cases besides aquaculture where this estimating method would be useful?

GLOSSARY

Broodstock: Adult fish retained for spawning.

Grow-out Pond: An aquatic environment in which finfish are reared until market size.

Juveniles: Young organisms, not fully grown or sexually mature.

Lease: The renting of a site or the rent agreement.

Sampling: The act of removing and examining a few organisms from a population in order to gain information.

Seed: Immature stage of the organisms, used as stock to begin a long-term aquaculture project.

Seine: A large fishing net weighted along the bottom.

Stocking Rate: The density of new organisms introduced to a given environment.

Variable: A quantity that changes.

MAKING CONNECTIONS: ADDITIONAL ACTIVITIES AND EXTENSIONS

• Careers in Aquaculture

Have individual students choose a career related to aquaculture, research it, and draft a hypothetical cover letter and résumé to obtain that job.

• Aquaculture Job Description

Have students develop a hypothetical job description for some of the aquaculture careers listed above. This will give them a sense of the qualifications necessary for such work.

• Short Story

Have students write a creative short story from the cultured species perspective on their journey from developing egg or cell to plate (or freedom if you choose to focus on aquaculture for the purpose of restoration efforts). Stories should include the various stages of aquaculture as it relates to their particular species production. Although accuracy is important, creative writing should be the principal goal.

ADDITIONAL RESOURCES

Boghen, Andrew D. *Cold-Water Aquaculture in Atlantic Canada*. N.p.: The Atlantic Institute for Research on Regional Development, 1995.

Iversen, Edwin S. and Kay K. Hale. *Aquaculture Sourcebook: A Guide to North American Species*. New York: Van Nostrand Reinhold, 1992.

National Research Council. *Marine Aquaculture: Opportunities for Growth*. Washington: National Academy Press, 1992.

Swift, Donald R. *Aquaculture Training Manual*. Cambridge, MA: Fishing News Books Blackwell Science Publications, 1993.

Wolfe, Louis. *Aquaculture: Farming in Water* (juvenile literature). New York: G.P. Putnam's Sons, 1972.

Water: The “Aqua” in Aquaculture

KEY CONCEPTS

Water is an invaluable, recyclable resource which encompasses over two-thirds of the Earth's surface. Of all the water present on earth, only a small fraction is composed of fresh water. The overwhelming majority is salt water found in the oceans. The hydrologic cycle demonstrates how water changes phases and locations, but is neither created nor destroyed. Clean water is essential to the survival of aquatic plants and animals. Therefore, clean water is essential to aquaculture. Aquaculturists must maintain good water quality. To insure this, they regularly test the water for such things as temperature, pH, dissolved oxygen and carbon dioxide, ammonia, hardness, and bacteria to determine whether they are maintaining good water quality for the sake of the species they are culturing and for the aquatic environment as a whole.

LESSON OVERVIEW

Students will conduct an activity which demonstrates the breakdown of fresh and salt water and explains the water cycle. Students will conduct a variety of mini-experiments which demonstrates various properties of salt water. Depending on access to water testing equipment and chemicals, a number of analyses specific to aquaculture can be tested.

LEARNING OBJECTIVES

After completing this chapter, the student will be able to:

- Diagram the water cycle.
- Explain why the supply of water on Earth is finite.
- Describe the breakdown of fresh and salt water on Earth.
- Demonstrate an understanding of the physical and chemical properties of water.
- Conduct aquaculture water quality tests.
- Demonstrate chemical analysis skills.
- Demonstrate measurement skills.
- Demonstrate knowledge of the scientific method.
- Gather, record, analyze, and report data.
- Make predictions based on observations.

LEARNING RESULTS

SALTWATER WONDERS

- E. Structure of Matter:** Students will understand the structure of matter and the changes it can undergo.
2. Analyze how matter is affected by changes in temperature, pressure, and volume.
- J. Inquiry and Problem Solving:** Students will apply inquiry and problem solving approaches in science and technology.
1. Make accurate observations using appropriate tools and units of measure.
 2. Verify, evaluate, and use results in a purposeful way.
 3. Recognize, extend, and create patterns and cycles using concrete products and examples of data and ideas or theories.
- K. Scientific Reasoning:** Students will learn to formulate and justify ideas and to make informed decisions.

3. Develop generalizations based on observations.
- L. **Communication:** Students will communicate effectively in science and technology.
 3. Make and use appropriate symbols, pictures, diagrams, scale drawings, and models to represent and simplify real-life situations and solve problems.

TESTING WATERS

J. **Inquiry and Problem Solving:**

1. Make accurate observations using appropriate tools and units of measure.
2. Verify, evaluate, and use results in a purposeful way.

MATERIALS

Overhead projector; *Water Cycle* transparency; one clear gallon container and two small clear jars; graduated cylinders; copies of the *Saltwater Experiments* handout; scissors; glue; index cards; several gallons water; aquarium, kosher, or canning salt; materials for individual saltwater experiments (see *What You Need* under “Saltwater Wonders” activity); water testing equipment and/or chemicals for mixing solutions (see “Testing the Waters” activity), beakers, glass or plastic containers, safety glasses, eye droppers.

BACKGROUND

See individual activities for additional information and Appendix A for more detailed information on water quality testing.

(Used with permission through arrangement with Schlitz Audubon Center of the National Audubon Society, 1111 East Brown Deer Road, Milwaukee, WI 53217. Reprinted from copyrighted material, Living Lightly on the Planet. All rights reserved.)

Photographs of Earth taken from the perspective of outer space reveal a watery world. This image coincides with a commonly held conception of water abundance. Ours is a water-rich planet. Problems we encounter with water shortages arise due to unequal distribution and unwise use of this life-sustaining resource. This investigation begins with a study of the water cycle. Students will see that the water we use on Earth today is the same water that filled the water jugs of the ancient Egyptians. Water moves in a closed system with no additional inputs from the atmosphere. We will never have more water on Earth than we have today.

The Water Cycle

Discuss the cycling of water on Earth. The immensity of the cycle is illustrated in the following figures. (Help your students visualize the size of a cubic mile before discussing these figures. For example, eight city blocks equal one mile. Students could try visualizing a cube eight city blocks in length, width, and height.)

- At any given moment, an average of 3,100 cubic miles of water droplets and water vapor is distributed throughout the atmosphere.
- Once every 12 days, all of the moisture in the air falls as precipitation and is subsequently replaced.
- Ninety-five thousand cubic miles of water are evaporated into the atmosphere annually; 80,000 from oceans, 15,000 from land.
- This is balanced by 95,000 cubic miles of precipitation which fall back to the Earth and into oceans; 90,000 cubic miles on land which runs off into rivers and streams and back into oceans, and 15,000 cubic miles which percolates into the soil.

WATER CYCLE

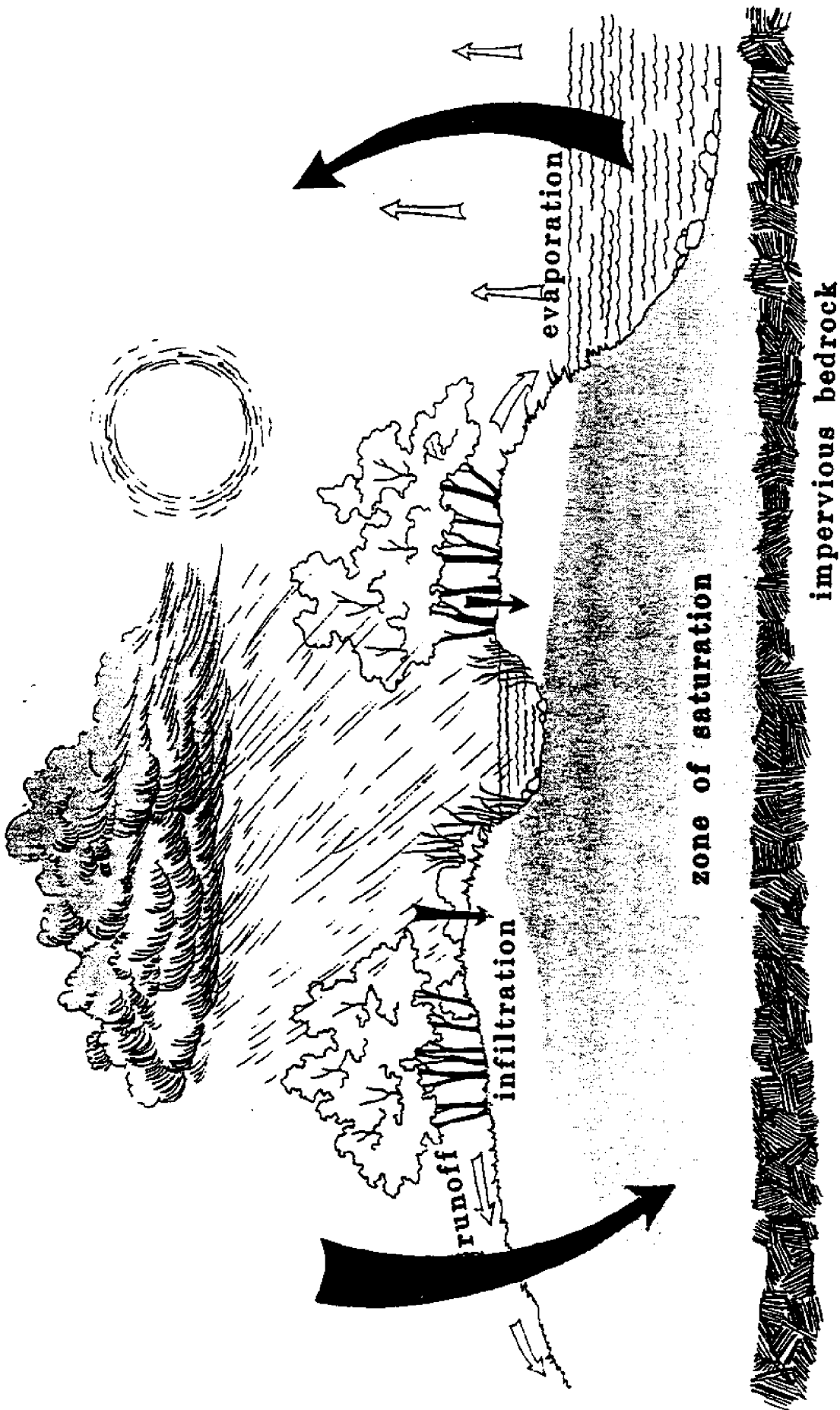

Where the Water Is

In the face of such water abundance, why are there water shortages? The breakdown of fresh and salt water on the planet is outlined below.

Distribution of Earth's Water

Location	%
Ocean	97.3
Fresh	2.7
Distribution of fresh water:	
Ice caps and glaciers	77.2
Groundwater and soil moisture	22.4
Lakes and wetlands	0.35
Atmosphere	0.04
Stream channels	0.01

Source: Water Management for Arid Lands In Developing Countries, A. K. Biswas et al., p. 10.

Water Distribution Demonstration

1. The following demonstration could be used to help your students conceptualize the breakdown of fresh and salt water.
2. Fill a large, clear container with 100 ounces (oz) or 12-1/2 cups of water. This represents 100% of the Earth's water.
3. Pour 3 ounces into a small, clear container to roughly represent the percentage of fresh water on the planet.
4. From the three-ounce container, pour 2-1/4 oz into a third container. This represents the amount of water in ice caps and glaciers.
5. The water remaining in the second container represents the percentage of water available for our use. You might want to label the containers beforehand so students can refer to the labels as you demonstrate.

(Note: If you wish to use metric units in the demonstration, begin with 3 liters of water to represent the Earth's total water. Then pour 90 milliliters (ml) into a second container to represent the percentage of fresh water. From the 90 ml, pour off 67-1/2 ml into a third container to represent the amount of water in ice caps and glaciers. The amount remaining in the second container represents the amount available to us for freshwater uses.)

ACTIVITY 1 : SALTWATER WONDERS

(Reprinted with permission of the National Wildlife Federation from the Diving into Oceans issue of NatureScope. For more information about National Wildlife Federation and its educational programs, call (703) 790-4100.)

Information

Here's a hands-on way for your students to discover some of the characteristics of seawater and to think about how these properties might affect life in the ocean.

Preparation

Before you get started, make copies of the experiments. Also make up several gallons of salt water by mixing two tablespoons of aquarium, kosher, or canning salt per quart of water. Aquarium salt is available in aquarium stores and some pet stores. The students will be using this salt water in many of the experiments. (It's referred to in the experiments as "saltwater solution.") Store the salt water in airtight containers in a cool place until the students need it.

Procedure

1. Begin by dividing the students into groups of four. Explain that each group is going to complete five different experiments.
2. Tell them that before they do an experiment, they should read through the directions carefully.
3. Then, using the questions under "Make a Prediction," they should write down on a sheet of paper what they think is going to happen.
4. Next, they should do the experiment and record the results. Afterward they should answer the questions listed under "Brain Busters."

- Once everyone has had a chance to finish experiment #1, get all the students back together and talk about the results and the questions.
- Use the information under "What Should Have Happened," to help with the discussion. Then let students start working on the next experiment.

(Note: Depending on how much time you have, you might want to do these experiments as demonstrations and then discuss them with the students.)

Discussion

- Why is it important to test water quality? Why is it important for an aquaculturist to perform these tests?
- Other than these tests and tasting, list some indicators you could use to determine water quality.
- What are some environmental factors that cause water test results to vary? What are the effects of this variance (both high and low levels) on aquatic life? What can be done to purposely manipulate each of the water quality parameters?

Experiments With Salt Water

#1 Under Pressure

What You Need:

1-quart milk carton, 3 identical nails, ruler, margarine or small cottage cheese tub, cup or other container, 9 x 13" baking pan, water.

What To Do:

- Open the entire top of the milk carton. Then push each of the 3 nails through the cardboard on one side of the carton so they are in a column (see diagram). Make sure that the bottom nail is at least 3 inches above the bottom and all the nails are at least 1 inch apart.
- Lay the ruler down the middle of the pan so that the 12-inch end of the ruler is touching one end of the pan.
- Place the empty margarine tub upside down in the baking pan at the 1-inch end of the ruler. The margarine tub should be on top of the ruler. Then set the milk carton on top of the tub so that the nails point toward the 12-inch end of the ruler (see diagram).
- Fill the milk carton with water all the way to the top.
- Pull all 3 nails out of the milk carton at the same time and then slowly pour water into the milk carton so that it's always filled.
- As the water squirts out the nail holes, watch to see how far each jet goes.

Make a Prediction: Will the water coming from each hole travel the same distance or will some jets travel farther than others?

Brain Busters: What did you observe and why did it happen? What might this tell you about how pressure changes the deeper you go in the ocean?

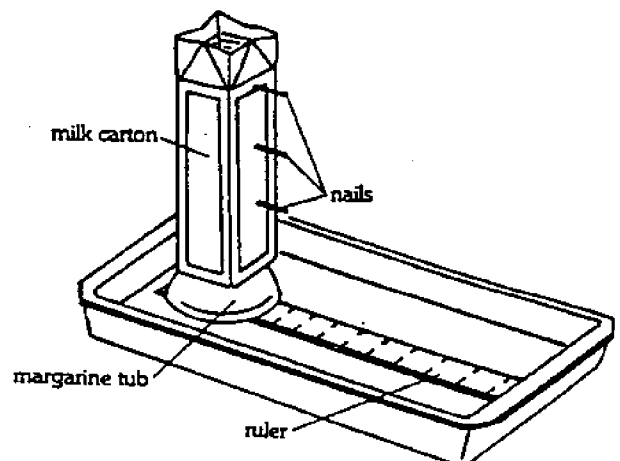

#2 Hot and Cold

What You Need:

4 containers, clear plastic cup, measuring cup, measuring spoon, saltwater solution, aquarium, kosher or canning salt, hot tap water, food coloring, medicine dropper, and refrigerator.

What To Do:

1. Pour 1 cup of saltwater solution into one of the containers and label it solution A. Then put it in a refrigerator for at least 2 hours.
2. Pour 1 cup of hot tap water into another container and add 1-1/2 teaspoons of salt. Stir until all salt is dissolved. Label this container solution B.
3. Pour a small amount of solution B into a different container, add 4 or 5 drops of food coloring, and stir well. Label this container solution 1.
4. Fill the clear plastic cup with about 2 inches of solution A. Then drop about 20 drops of solution 1 into the cup, using a medicine dropper. Watch to see what happens as the colored, warm salt water drips into the cold salt water. Then clean out the plastic cup.
5. Pour a small amount of solution A into a different container, add 4 or 5 drops of food coloring, and stir well. Label this container solution 2.
6. Fill the clear plastic cup with about 2 inches of solution B. Then drop about 20 drops of solution 2 into the cup, using the dropper. Watch to see what happens as the colored, cold salt water drips into the warm salt water.

Make a Prediction: When you add warm salt water to chilled salt water, will it float at the surface, sink to the bottom, or mix right in? When you add chilled saltwater to warm salt water, will it float, sink, or mix right in?

Brain Busters: What did you observe and why did it happen? Based on this experiment, where would you find the warmest water in the ocean, at the surface or close to the bottom?

#3 The Salty Sea

What You Need:

4 containers; clear plastic cup; measuring cup; saltwater solution; aquarium, kosher, or canning salt; measuring spoon; food coloring; medicine dropper.

What To Do:

1. Pour 1 cup of saltwater solution into each of 2 containers and label them solution A and solution B.
2. Make solution A extra salty by adding 3/4 teaspoon of salt to it and stirring until the salt is dissolved.
3. Pour a small amount of solution A into another container, add 4 or 5 drops of food coloring, and stir well. Label this container solution 1.
4. Fill the clear plastic cup with about 2 inches of solution B. Then drop about 20 drops of solution 1 into the container, using a medicine dropper. Watch to see what happens as the colored, extra-salty water drips into the less salty water. Then clean out the plastic cup.
5. Pour a small amount of solution B into another container, add 4 or 5 drops of food coloring, and stir well. Label this container solution 2.

6. Fill the clear plastic cup with about 2 inches of solution A. Then drop about 20 drops of solution 2 into the container, using a medicine dropper. Watch to see what happens as the colored salt water drips into the extra-salty water.

Make a Prediction: When you add extra-salty water to salty water, will it float at the surface, sink to the bottom, or mix right in? When you add salty water to extra-salty water, will it float at the surface, sink to the bottom, or mix right in?

Brain Busters: What did you observe and why did it happen? Based on this experiment, what do you think happens to river water, which is fresh water, as it flows into the sea? Does it tend to float or does it sink to the bottom?

#4 The Current Connection

What You Need:

9" x 13" glass baking pan or other large, clear container; saltwater solution; container; plastic ice cube tray; food coloring; lukewarm tap water; freezer.

What To Do:

1. Add 4 or 5 drops of food coloring to a container of saltwater solution and stir well.
2. Fill 4 ice cube compartments in a plastic ice cube tray halfway with the colored salt water and freeze.
3. Fill a clear baking pan with lukewarm tap water. Then line up the 4 colored ice cubes along one end of the baking pan, using your finger to keep them from floating away. Look into the pan from the side and watch what happens as the ice cubes melt.

Make a Prediction: As water from the ice cubes melts, will it sink straight to the bottom, float at the surface, or mix in?

Brain Busters: What did you observe and why did it happen? Based on this experiment, what do you think happens to ocean water as it's chilled at the polar regions?

#5 Changing Temperatures

What You Need:

2 large glass jars with lids, 2 thermometers that fit inside the jars, water, graph paper, refrigerator.

What To Do:

1. Set a thermometer inside a glass jar and screw the lid on. A few minutes later, record the temperature on the thermometer. This is the temperature of the air inside the jar.
2. Fill the other glass jar with water that's the same temperature as the air inside the first jar. Put a thermometer in the jar and screw the lid on.
3. Put both jars in the refrigerator and record their temperatures every 3 minutes for 21 minutes. Graph the results.

Make a Prediction: After you set the jars in the refrigerator, will they change temperature at the same rate or will one change faster than the other?

Brain Busters: What did you observe and why did it happen? Based on this experiment, do you think the ocean changes temperature at the same rate as the air around it? How do you think temperatures along the coast might compare with an area 100 miles inland during the summer? During the winter?

What Should Have Happened

1. Under Pressure

The middle jet of water would have traveled farther than the top jet, and the bottom jet of water should have traveled farthest of all. Explain that water near the bottom of the milk carton is under more pressure than the water at the top because it has the weight of all the water on top of it. In the ocean, water pressure also increases with depth and in the deep ocean, the pressure can be tremendous. At 30,000 feet the water pressure can be as great as having the weight of an elephant pushing against every square inch of your body! Life in the deep ocean is adapted for these conditions.

2. Hot and Cold

The warm, colored salt water (solution 1) should have floated on top of the cold salt water (solution A). Almost all of the colored, cold salt water (solution 2) should have sunk to the bottom of the warm salt water (solution B). Explain that since warm water is less dense than cold water, it floats on top. Because cold water is denser than warm water, it sinks to the bottom. In the ocean, the warmest water is found at the surface and the water at the bottom of the ocean is very cold.

3. The Salty Sea

The colored, extra-salty water (solution 1) should have sunk to the bottom of the uncolored salt water (solution B). The colored, less salty water (solution 2) should have floated on top of the uncolored, extra-salty water (solution A). Explain that the saltier water is, the denser it is. And denser water sinks through less dense water. For example, extra-salty water in the ocean tends to sink. And as fresh river water flows into the sea, it tends to stay near the surface-flowing over the saltier, denser water in the sea.

4. The Current Connection

Colored water from the ice cubes should have sunk straight to the bottom of the pan and then moved along the bottom toward the far end. Explain that the melting water sank because it was colder and saltier and therefore denser. As the ice cubes melted, the continuous stream of cold, salty water took the path of least resistance; it flowed along the bottom, underneath the less dense tap water. As ocean water is chilled at the polar regions, it sinks and flows toward the equator. These deep, coldwater currents are important in ocean circulation.

5. Changing Temperatures

The temperature of the air inside the first jar should have changed more rapidly than the temperature of the water inside the second jar. Explain that air changes temperature much more rapidly than water, so the temperature of the atmosphere changes more rapidly than that of the ocean. And air that blows across the sea tends to have cooler temperatures in the summer and warmer temperatures in the winter than areas farther inland.

ACTIVITY 2: TESTING THE WATERS

Information

The procedures for the activity will vary depending on the water testing method you employ. Aquaculture test kits and electronic meters are available from HACH and La Motte but are quite expensive. Test strips are relatively inexpensive, are available from Environmental Test Systems, and can test for pH, nitrite and hardness. Some inexpensive water testing kits for aquaria can be found in pet supply stores. To determine dissolved oxygen and carbon dioxide, reagents can be mixed from chemicals found in most chemistry labs. Take extreme caution when using chemicals. Read and follow all directions in the material safety data sheets which accompany all chemicals.

Preparation:

Provide freshwater samples for the class to compare. A classroom aquarium provides an excellent source of water to test and compare with tap water. Make sure that the aquarium has not been recently cleaned (within the last week).

*If you are mixing your own reagents, prepare the following solutions:

Solution #1	48% manganous sulfate
Solution #2	70% potassium hydroxide & 15% potassium iodide
Solution #3	concentrated sulfuric acid
Solution #4	2% starch
Solution #5	0.31% sodium thiosulfate
Solution #6	phenolphthalien solution
Solution #7	0.4% sodium hydroxide solution

*Exercise extreme caution when working with chemicals. Make sure that gloves and safety glasses are worn at all times.

Photocopy and distribute the following lab *Testing the Waters* to students.

LAB HANDOUT

Testing the Waters

Water Testing Methods

For each sample test, students will be measuring out 100 milliliters (ml) of the two different water samples. Always collect and measure samples with clean, glass or plastic equipment. Samples must be tested shortly after collected in order for the tests to be accurate. Unless solutions are being used, it will be assumed that students will follow the specific instructions included in the packaging of the particular test they are using (i.e., titrimetric, colorimeter, electronic meter, or test strip).

Procedure

1. Divide the class into lab groups and distribute safety glasses to each student.
2. Each group will be provided with a set of premixed solutions which are numbered and labeled.
3. In a clean glass or plastic container, each group will collect a water sample from each source (i.e., aquarium water and tap water). Groups should collect enough water to do the following tests. Record the temperature of each water sample in the table below.
4. For each test, students will measure out 100 ml of each water source into small, clean, glass or plastic flasks or beakers. These containers should be labeled (aquarium or tap) and must be cleaned out thoroughly between tests. Eye droppers should be thoroughly cleaned out when changing solutions.

Water Tests

(For pH, ammonia, nitrite, and hardness, follow the specific instructions based on your test method. For dissolved oxygen and carbon dioxide, titrimetric procedures are included.)

5. **pH:** Perform the test according to packaging instructions and record your results in the table below.
6. **Dissolved Oxygen:** Pour 100 ml of water from each source *slowly* into each container to avoid aerating your sample. Perform the instructed test and record your results in the table below. If you are using the premixed solutions, adhere to the following directions:
 - Holding the eye dropper close to the water, add 10 drops of solution #1 to each water sample.
 - Using a clean eye dropper, add 10 drops of solution #2 to each water sample.
 - Gently mix the samples by swirling the containers, taking care to avoid splashing.
 - Using a clean eye dropper, add 15 drops of solution #3 to each water sample.
 - Again, gently mix the samples by swirling the containers.
 - While mixing, add 5 drops of solution #4. Your sample should turn a dark blue.
 - Add one drop at a time of solution #5, gently mixing after each drop has been added.
 - Repeat the above step while keeping track of how many drops are added.
 - Stop when each sample is colorless and note how many drops of solution #5 were used.
 - In order to convert your number to parts per million (ppm) of dissolved oxygen, divide the number of drops by 20 and record in the table below. Carry divisions to one decimal place.
7. **Carbon Dioxide:** Perform the test according to packaging instructions and record your results in the table below. If you are using the premixed solutions, adhere to the following directions:
 - Add 5 drops of solution #6 to each water sample and mix by gently swirling containers. *(If a pink color forms and remains, this indicates that there is no carbon dioxide in your water sample.)*

- Using a clean dropper, add solution #7 one drop at a time, counting as you go and swirling solution after every few drops. When a light pink color forms and remains after swirling, you can stop adding solution #7 and note the number of drops that were added.
 - In order to convert your number to parts per million of carbon dioxide, multiply the number of drops used by 5 and record it in the table below.
8. **Ammonia, Nitrite, and Hardness:** Perform the instructed test and record your results in the table below.
 9. **Salinity:** Salinity can be measured using any of the test kits mentioned above, an electronic meter, or a hydrometer. Record your results in the table below.

Test	Unit (measured in)	Sample #1 (from)	Sample #2 (from)
Temperature			
Dissolved Oxygen			
Carbon Dioxide			
Ammonia			
Nitrite			
Hardness			
Salinity			

10. Pool the results to see if groups obtained similar results.

Discussion:

1. What are the similarities and differences between the two samples? Examine the test results.
2. Are your results compatible with expected results? Why? Why not?
3. What are the sources of potential errors?

STUDENT HANDOUT

Water Quality Testing in Aquaculture

Maintaining good water quality is essential for any aquaculture operation. Aquaculturists must carefully monitor water for: temperature, pH, ammonia, nitrate, water hardness, dissolved oxygen, carbon dioxide, and salinity. There are several different methods for testing water quality.

These test methods include:

Titrimetric

This analysis is based on titration which is a method of determining the strength or concentration of a solution by adding known amounts of a reacting chemical until you can see a color change.

Calorimetric

This method determines the concentration of many substances in water by the color which the chemical test reaction produces. The darker the color, the greater the concentration. The sample *experimental* color is compared to a standard *control* color.

Electronic Meters

Modern technology has developed electronic meters which can measure many different water quality factors by passing an electric current through the water sample. Again it is important that a standard, control water sample be used to **calibrate** the meter.

Aquaculturists must monitor several factors such as:

Temperature

Water temperature is extremely important to monitor, as it affects the life processes of all aquatic organisms. Temperature determines which aquatic organisms can be cultured, the solubility of important gasses like oxygen, and the **physiology** of species being cultured.

Salinity

Salinity tests measure the concentration of dissolved salts in the water, which is measured in parts per thousand (ppt). Even drinking water has some salinity, usually less than 0.5 ppt whereas sea-water averages around 35 ppt.

pH

This test measures the concentration of hydrogen ions in the water. The pH scale goes from 0 to 14 where zero is the most **acidic** and 14 is the most **basic** and 7 is **neutral**. Generally, fish cannot live in a pH below 4 or above 11. Ideally, a pH between 6 and 9 is optimal for fish reproduction and development.

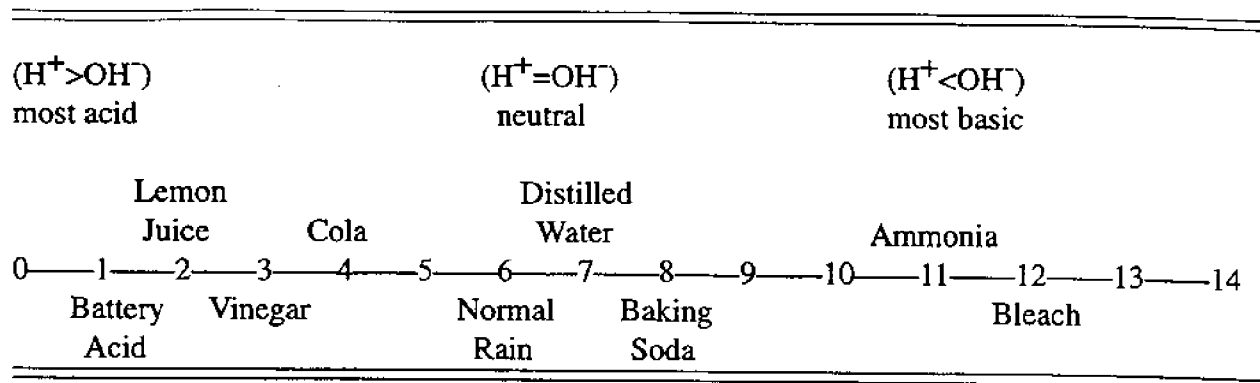

pH scale which shows the values of some common substances

(Source: U.S. Fish and Wildlife Service)

Dissolved Gases

There are many naturally occurring gases which dissolve in water. Dissolved gases which are tested for include: Oxygen (O₂), Carbon Dioxide (CO₂), Nitrogen (N₂), Ammonia (NH₄⁺ and NH₃), Hydrogen Sulfide (H₂S), Chlorine (Cl₂) and Methane (CH₄). The quantity of these various gases determines the quality of the water for culturing aquatic species. In order to accurately test for these gases, it is best to conduct your tests right at the water site rather than taking a sample and conducting the test later in a laboratory. Ammonia, however, is the most stable of the gases listed above, and will give a fairly accurate reading if it is processed within one day of the sample collection.

Dissolved Oxygen

All living organisms require oxygen. Terrestrial (land) organisms get their oxygen from the air, whereas aquatic (water) organisms get their oxygen from the water. Dissolved oxygen is measured in milligrams per liter (mg/L) or parts per million (ppm). There is a lot less oxygen available in water than in air. Most dissolved oxygen in water comes from the atmosphere. The ability of oxygen to dissolve in water depends on salinity, temperature, altitude, weather, **photosynthetic** algae concentrations and depth of water. For example, as water gets warmer and/or more **saline**, its ability to hold oxygen decreases. As a result, there would be less oxygen available in warmer, saltier water for the species you are culturing. Some species such as trout and salmon require much oxygen. These species thrive in cold water where oxygen is more plentiful. Warmwater species, such as catfish and carp, do not have such high oxygen requirements and so they thrive in warm water. Usually, surface waters contain at least 7 mg/L of oxygen. Most aquatic animals need at least 4 mg/L of oxygen to maintain good health. When aquatic animals do not get enough oxygen or are overcrowded, they become *stressed* which makes them more susceptible to disease.

Carbon Dioxide (CO₂)

All living organisms, even plants, undergo a process called **respiration** which produces carbon dioxide. Carbon dioxide readily dissolves in water. This can be a problem since high concentrations of carbon dioxide can reduce the ability of aquatic animals to remove oxygen from the water. Although carbon dioxide rarely exceeds 5 mg/L at the surface of the water, it can reach over 60 mg/L at lower depths, or when fish are overcrowded. Fish pens can be aerated to add oxygen and/or remove excess carbon dioxide. Oxygen and carbon dioxide enter the water via the atmosphere, and from the plants and animals which inhabit the water.

Ammonia

Ammonia enters the water from a variety of pathways. As plants and animals die, bacteria breaks down larger molecules into ammonia. Human sewage and waste from aquatic animals also raises ammonia levels, as does fertilizer runoff from agricultural land and livestock pens. When you have increased levels of ammonia and nitrogen, this nitrogen source acts as a plant fertilizer and can lead to an **algae bloom** whereby plants grow and decay more rapidly, thus reducing the level of dissolved oxygen. In the water, ammonia combines with oxygen to form nitrites (NO_2) and nitrates (NO_3). Nitrogen can be toxic to aquatic life at levels above 0.4 mg/L. When there are high nitrogen levels, nitrogen, rather than oxygen, bonds to the hemoglobin molecule in the bloodstream causing a condition in fish which is called *brown blood disease*. In aquaculture, as in one's hobby aquarium, ammonia must be carefully monitored and regulated since an excess of ammonia can be lethal to its inhabitants.

Hardness

Total water hardness is a measure of Calcium(Ca) and Magnesium (Mg) in mg/L of an equal amount of calcium carbonate (CaCO_3). Total hardness relates to total alkalinity and determines the ability of a sample of water to stabilize pH. Aquatic organisms do well if hardness/alkalinity measures between 20 and 300 mg/L. Hardness below 20 is not good, but it is possible to raise the value by adding lime, which is alkaline, to the water.

GLOSSARY

Acidity: A measure of the hydrogen ions in solution (H^+).

Acid Solution: Contains more hydrogen ions (H^+) than hydroxide anions (OH^-) or $\text{pH} > 7$.

Algae Bloom: A growth of algae resulting from excessive nutrient levels or other physical and chemical conditions that enable algae to reproduce rapidly.

Alkalinity: A measure of the hydroxide anions in solution (OH^-).

Anions: A negatively charged ion.

Basic Solution: Contains more hydroxide anions (OH^-) than hydrogen ions (H^+) or $\text{pH} < 7$.

Calibrate: To check, adjust, or determine by comparison with a standard.

Cation: A positively charged ion.

Concentration: The amount of a specified substance in a unit amount of another substance.

Ion: An atom or group of atoms that has either lost one or more electrons (a cation), or gained one or more electrons (an anion).

Neutral: A solution that is neither acidic or alkaline ($\text{pH} = 7$).

Photosynthetic: Organisms which can make their own food using carbon dioxide, water, and energy from the sun, and releasing oxygen as a by-product.

Respiration: The oxidative process occurring within living cells by which the chemical energy of organic molecules is released in a series of metabolic steps, involving the consumption of oxygen and the liberation of carbon dioxide and water.

Saline: Of, relating to, or containing salt.

MAKING CONNECTIONS: ADDITIONAL ACTIVITIES AND EXTENSIONS

- Density column

Challenge students to create a density column. You will need 1 liter of water; red, blue, and yellow food coloring; table salt; four 500ml beakers; 4 paper cups per group; and one 100ml beaker per group. Have the solutions ready for the students. Take one liter of water and add salt until no more will dissolve; call this saturated solution A. Take 200 ml of A, the saturated solution, and add 100 ml of plain water; this is solution B. Take another 100 ml of solution A and add 200 ml of plain water; this is solution C. Solution D is 300 ml of plain water. Add red food coloring to solution A, nothing for color to B, blue to C, and yellow to D. Give each group a sample of each solution in cups, and a glass beaker. Knowing what they do about density, see if they can determine the densest solution by layering the samples.

- Determining salinity

An inexpensive hydrometer can be purchased at your local pet store. Use the hydrometer to check the salinity in your saltwater aquarium. You can also use this instrument on your colored saltwater samples to quantify the students' results.

- Field trip to a local lake or river to perform water quality tests

Students can volunteer to monitor a local lake and report results to DEP by contacting the Division of Environmental Evaluation and Lake Studies at 207-289-3901.

- Research

Have students research the following questions: How does pressure affect marine organisms? What special adaptations do marine deep-diving mammals have?

ADDITIONAL RESOURCES

Andrews, William A. *Investigating Aquatic Ecosystems*. Scarborough, Ontario: Prentice-Hall Canada Inc., 1987.

Bright, Sarah S. *The Wild Gulf Almanac*. Wiscasset, ME: The Chewonki Foundation-Osprey Press, 1995.

Hoppe, Kathy. *A Catalog of Water Quality: Information & Educational Materials*. Augusta: Maine Department of Environmental Protection, 1995.

Lehnertz, Christine and Esperanza Stancioff. *The Qualities of Quality: A Workbook for Protecting the Critters in the Gulf of Maine* (A step-by-step guidebook to writing a Quality Assurance Project Plan-QAPP.) Orono: University of Maine Cooperative Extension, 1996.

Krum, Cynthia and Flis Schaffler. *Charting Our Course: An Activity Guide for Grades 6-12 on Water Quality in the Gulf of Maine*. Augusta: Maine Coastal Program, 1995.

Maine State Planning Office. *The Estuary Book*. Augusta: Maine Coastal Program, 1991.

Mitchell, Mark K. and William B. Stapp. *Field Manual for Water Quality Monitoring: An Environmental Education Program for Schools*. Dexter, MI: Thompson-Shore Inc., 1994.

Stancioff, Esperanza. *Clean Water: A Guide to Water Quality Monitoring*. Orono: Maine/New Hampshire Sea Grant Marine Advisory Program and University of Maine Cooperative Extension, 1996.

The Watercourse & Western Regional Environmental Education Council. *Project WET*. Boulder, CO, 1995.

University of Maine Cooperative Extension. *Connections to the Sea: A 4-H Guide to Marine Education*. Orono, ME, 1990.

Western Regional Environmental Education Council. *Project Wild Aquatic*. Boulder, CO, 1987.

Aquatic Ecology

KEY CONCEPTS

In order to culture aquatic organisms, we must understand the ecology of our many diverse aquatic ecosystems. These include freshwater ecosystems such as ponds, lakes, rivers and streams; and marine ecosystems such as the oceans, gulfs, bays and brackish ecosystems or estuaries, where fresh water and salt water meet and combine to create a unique environment. Basic ecological concepts which stress the interdependence of life will be addressed.

LESSON OVERVIEW

Students will take part in a simulation which depicts the ecological levels of organization. They will learn basic laws of ecology, especially as they relate to the aquatic environment. Students will demonstrate their knowledge of aquatic ecology and marine organisms in a game called *Ecotrivia* and an activity which simulates a marine food web.

LEARNING OBJECTIVES

After completing this chapter, the student will be able to:

- Define ecology.
- List the levels of ecology from species to biosphere.
- List the biotic and abiotic components of an ecosystem.
- List the different trophic, or feeding, levels.
- Define food chains and food webs.
- Define habitat and niche.
- Describe basic laws of ecology and apply them to aquatic ecosystems.
- List several different aquatic ecosystems.
- Apply ecological principles to aquaculture.
- Demonstrate correct use of a marine field guide.

LEARNING RESULTS

WEB OF LIFE

- B. Ecology:** Students will understand how living things depend on one another and on non-living aspects of the environment.
3. Analyze the effect of reproductive and survival rates on population size.
 4. Analyze the impact of human and non-human activities on the type and pace of change in ecosystems.
- K. Scientific Reasoning:** Students will learn to formulate and justify ideas and to make informed decisions.
3. Develop generalizations based on observations.
- M. Implications of Science and Technology:** Students will understand the historic, social, economic, environmental, and ethical implications related to science and technology.
2. Demonstrate the importance of resource management, controlling environmental impacts, and maintaining natural ecosystems.

MATERIALS

Blackboard, *Ecotrivia* questions (provided), *Gulf of Maine Organism Web*, photocopies of pictures of marine organisms (Appendix B), marine field guides, scissors, ball of string.

BACKGROUND

Ecology is the study of how living things interact with each other and with their environment. Ecology can be studied at many levels including:

Level 1: **Individual organism**

Level 2: **Population:** Any group of plants or animals of the same **species** living in the same place. (e.g., all the lobsters in the Gulf of Maine or all the Atlantic salmon in the Penobscot River)

Level 3: **Community:** All the living things in an area consisting of several different populations. For example, an **intertidal community** may be made up of different populations of seaweed, crabs, clams, barnacles, etc.

Level 4: **Ecosystem:** The relationship of the community with its environment or where it lives.

Level 5: **Biome:** A large geographic area which has its own unique characteristic communities. (e.g., arctic tundra, deciduous forest, grassland, desert)

Level 6: **Biosphere:** All biomes together which is the area on earth where all life exists.

Structure of an Ecosystem

The **ecosystem** is the basic unit of ecology and consists of both living (**biotic**) and non-living (**abiotic**) components. Abiotic components include the basics for life such as air, water, temperature, light, and soil; and chemical elements such as nitrogen, hydrogen, carbon, oxygen, and phosphorus. All these abiotic components provide **energy** and **nutrients** to the biotic components of an ecosystem. All parts of an ecosystem are interrelated and they can range in size from a small pond, to a rocky coast, and to the Atlantic Ocean.

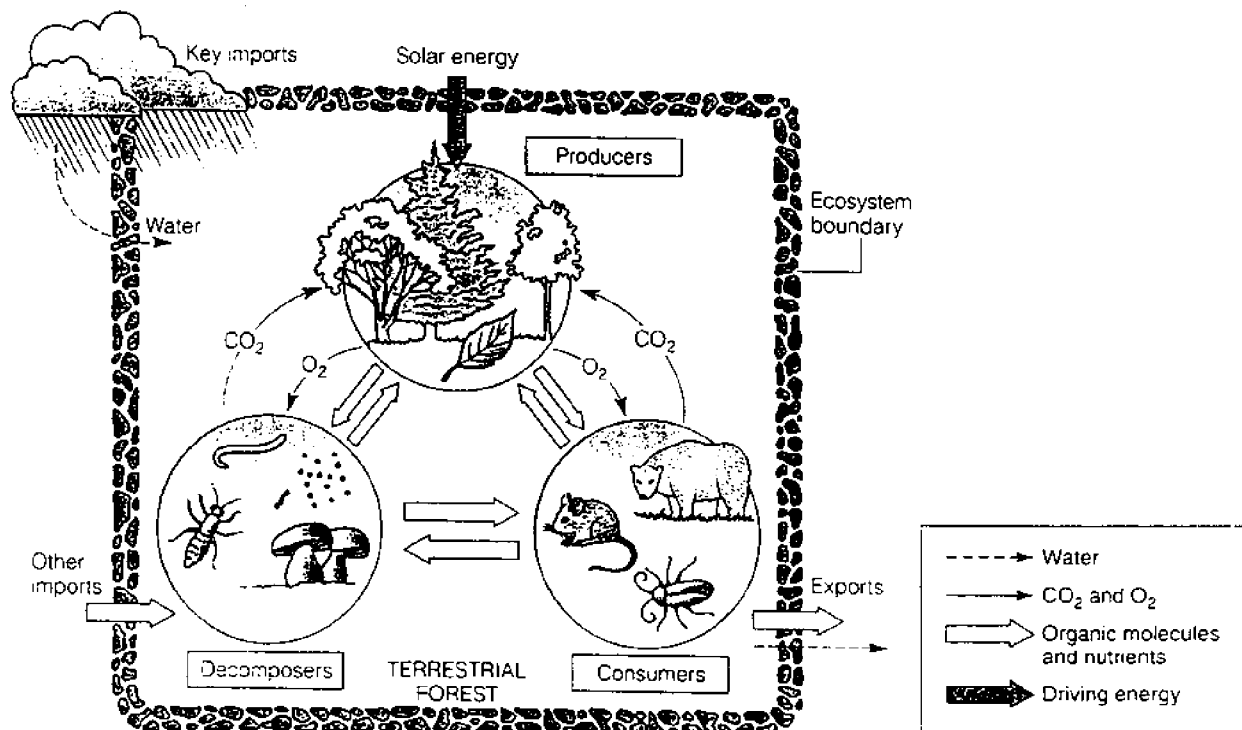

Individual organisms live in specific **habitats**. A habitat is a “home” which provides the necessities for life: food, water, oxygen, shelter, and space. There are many different habitats available within a given ecosystem. The role an organism plays within the community is called its **niche**. Habitats and niches may overlap for certain species. A habitat is like an animal’s address; a niche is its profession. For example, on a rocky shore, a periwinkle snail’s habitat is in the rockweed area of the **littoral (intertidal) zone** and its niche is grazing (feeding) on the seaweed and algae in this zone and providing food for other animals. Some species called “specialists” require a very specific habitat; others, called “generalists,” can survive in a variety of habitats.

Competition occurs when members of the same species or members of different species attempt to live together in a similar habitat/niche and there is a limited **resource** needed for their survival such as food, light, and space. Often competition requires that certain individuals, or an entire population, leave that area and search for another suitable habitat in order to survive.

Ecologists group living organisms according to their function in an ecosystem. These are divided into different trophic, or feeding, levels which include:

Producers: (Also called autotrophs) Green plants are producers because they make their own food using carbon dioxide, water and energy from the sun, and release oxygen as a by-product. This process is known as **photosynthesis**. **Phytoplankton** are the producers of aquatic ecosystems.

Consumers: (Also called heterotrophs) These organisms get their energy from eating other plants and animals.

Herbivores are **primary consumers** because they eat plants. (e.g., beavers, tadpoles, periwinkle snails and **zooplankton**)

Carnivores are **secondary consumers** because they eat primary consumers or other carnivores (e.g., seals, eagles, sharks, and trout). Carnivores, which feed on live animals, are called **predators** and their food is called **prey**. For example, an **osprey** is a predator because it feeds on fish which are considered its prey. Animals that feed on dead animals, which bald eagles often do, are considered **scavengers**. Many aquatic organisms are scavengers.

Omnivores such as **carp**, eat both plants and animals (carnivores *and* herbivores). Humans are omnivores.

Decomposers are specialized consumers which get their energy from dead or decaying plants and animals and their waste. Fungi, bacteria, and many insects are decomposers and serve an invaluable function in an ecosystem. They convert waste matter to nutrients which can be used again and are important recyclers in an ecosystem.

Animals and plants are connected by their feeding relationships called **food chains**. Indi-

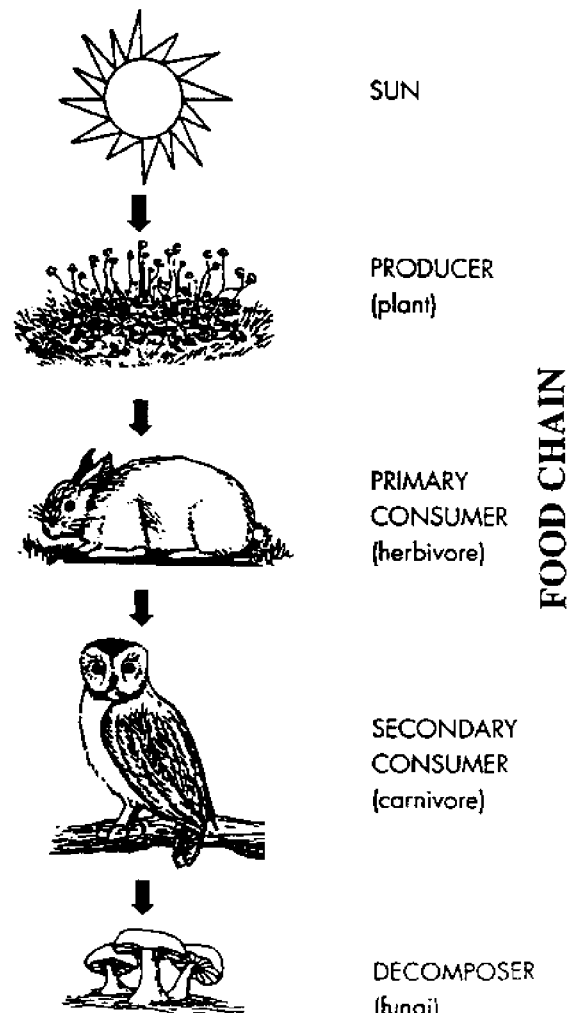

vidual organisms usually contribute to more than one food chain. These many food chains connect together to form an ecosystem's **food web**.

Some of the important basics of ecology can be simplified into the following statements:

1. Everything is connected to everything else.

This concept is demonstrated by:

- Food chains and food webs which link all biotic and abiotic factors
- Competition
- Predator-prey interactions

2. Everything has to go somewhere: The earth is finite and has limits.

This concept is demonstrated by:

- Life support cycles (Water and nutrient)
- Energy flow: Energy flows from the sun and through the trophic levels, losing energy as heat as it continues along the food chain.
- Pollution

3. Everything is always changing.

This concept is demonstrated by:

- Ecological succession: Plant and animal communities undergo change and pass through stages. (e.g., pond succession)
- Adaptation and natural selection
 - Physical or structural: Over long periods of time, plants and animals undergo changes which help them survive better in their specific environment.
 - Behavioral: Animals change their behavior in response to the environment.
 - Metabolic: Plants and animals change their body functions in response to the environment. (e.g., hibernation)

4. There is no such thing as a free lunch: There are environmental costs.

This concept is demonstrated by:

- Pollution
- Deforestation
- Pesticide/herbicide use

5. We are part of the earth: Humans are part of the earth and we play an active role altering the environment to suit our needs and desires. Human alteration of the biosphere has repercussions.

This concept is demonstrated by:

- Dredging/ wetland reclamation
- Coastal development
- Shoreline stabilization structures

There are several different aquatic ecosystems with their own unique set of species which are specifically adapted to living in that particular environment.

Some Freshwater Ecosystems

Freshwater ecosystems can be divided into standing waters (which do not move) and flowing waters (which move). Flowing water and standing water ecosystems have very different living and non-living components.

• Standing Waters

Ponds tend to have a lot of emergent vegetation because they are shallow enough that light can reach the bottom in most places.

Lakes have less aquatic vegetation because light is unable to reach the bottom in many places.

Marshes tend to be shallow, grassy, and lack open areas of water.

Swamps tend to be more shallow and have land patches and trees.

Bogs tend to be waterlogged and spongy, with acidic water.

• Flowing Waters

Flowing waters are classified by a system called stream orders and are categorized from smallest to largest as *brooks*, *creeks*, *streams*, and *ivers*.

Marine Ecosystems

Marine ecosystems differ from freshwater ecosystems in many ways: salinity, currents, waves, tides, productivity, and the living organisms which inhabit these ecosystems. Marine environments include oceans, rocky shores, sandy shores, salt marshes, mud flats, estuaries, and tide pools.

Oceans / Seas

- Pelagic (water environment)
 - Neritic (nearshore) waters
 - Oceanic waters (top to bottom): epipelagic, mesopelagic, bathypelagic, abyssopelagic, hadal
- Benthic (bottom environment - dune to deep sea trenches): supralittoral, littoral, sublittoral, bathyl, abyssal, hadal
- Photic Zone (the upper part of the water where photosynthesis takes place)
- Aphotic Zone (the lower part of the water where light cannot reach)

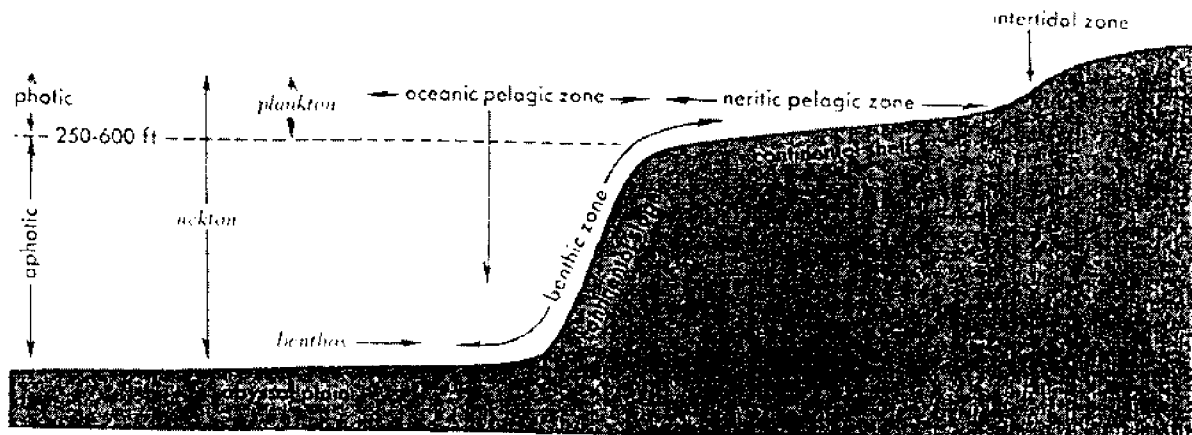

The structure of an ocean basin.

COASTAL ZONATION

ACTIVITY 1: ECOTRIVIA

Information

Since this chapter introduces so many new concepts and vocabulary, a game such as *Ecotrivia* is an excellent way for students to review what they have learned in a fun and challenging way.

Preparation

Trivia questions can be read from the sheet or written on a board or overhead. Use a blackboard as a scoreboard to record the responses of each team.

Procedure

1. Divide the class into two separate teams and give each team a name. Write the name of each team on the scoreboard.
2. To begin, ask team #1 a question. They will be allowed thirty seconds to discuss the question amongst themselves and come up with an answer. If they answer correctly, the team receives 2 points. If they answer incorrectly, team #1 gets zero points and team #2 gets a chance to answer the question. If team #2 answers the question correctly, they will get 1 point.
3. Direct the second question to team #2 and follow the same procedures as in step 2.

Questions

1. Ecology is the study of how living things interact with each other and with their _____.
[environment]
2. Habitat is to address, as niche is to _____. [profession]
3. What are the five components of a habitat? (must get all five correct to get any credit)
[food, water, shelter, oxygen, space]
4. Grasslands, deserts, arctic tundra are all examples of what? [biomes]
5. Name four types of standing water. [ponds, lakes, marshes, swamps, and bogs]
6. Fungi and bacteria are examples of what? [decomposers]
7. What do primary consumers eat? [plants/producers]
8. What do secondary consumers eat? [primary consumers or other carnivores]
9. Green plants are producers because they convert sunlight, carbon dioxide, and water into food in a process called _____. [photosynthesis]
10. Name four kinds of marine ecosystems. [estuaries, marshes, sandy shores, mud flats, tide pools, rocky shores]
11. If you eat both plants and animals, you are called an _____. [omnivore]
12. Any group of plants or animals of the same species living in the same place is called a _____. [population]
13. All the living things in an area consisting of several different populations is called a _____. [community]
14. When a pond turns into a grassland, or a field into a forest, this is known as _____. [succession]
15. A marine ecosystem where fresh water and salt water meet is called an _____. [estuary]
16. Name three of the five statements which describe the general principles of ecology. [listed above]

17. An animal which is hunted, killed and eaten is called _____. [prey]
18. When two animals occupy a very similar habitat and niche in the same area, they are said to be in _____. [competition]

ACTIVITY 2: WEB OF LIFE

Information

This activity can be used as a way of reviewing what students have learned about aquatic communities and to familiarize them with marine ecosystems. Students demonstrate the interconnectedness of all biotic and abiotic components of an ecosystem in a hands-on game. For younger students, pictures can be colored and holes punched so that they can wear them around their neck for the activity. For older students, you may choose to leave out the string and simply discuss the various connections.

GULF OF MAINE ORGANISM WEB

Organism	Food	Predators	Habitat
Bloodworm (<i>Glycera dibranchiata</i>)	bloodworms other marine invertebrates	worms, crustaceans fish	intertidal, subtidal
Soft-shell clam (<i>Mya arenaria</i>)	plankton	green crabs, sea stars fish, whelks, lobsters	intertidal, subtidal
American oyster (<i>Crassostrea virginica</i>)	plankton	crabs, sea stars, whelks	estuaries
Sea scallop (<i>Plactopecten magellanicus</i>)	plankton	sea stars, fish, crabs	subtidal
Periwinkle (<i>Littorina littorea</i>)	algal film	crabs, dog whelks, sea stars, fish	intertidal
Dog whelk (<i>Thais lapillus</i>)	clams, barnacles, periwinkles, mussels	sea stars	intertidal
Waved whelk (<i>Buccinum undatum</i>)	dead organisms	sea stars, lobsters	subtidal
Horseshoe crab (<i>Limulus polyphemus</i>)	dead organisms, small clams, worms	sea gulls, fish	intertidal, subtidal
Short-finned squid (<i>Illex illecebrosus</i>)	fish, krill	fish, marine mammals	mid ocean
Green crab (<i>Carcinus maenas</i>)	clams, mussels, periwinkles	lobsters, gulls	intertidal, subtidal
Northern shrimp (<i>Pandalus borealis</i>)	plankton, shrimp	fish	mid ocean
Lobster (<i>Homarus americanus</i>)	mussels, crabs, clams, lobsters	lobsters, cod, sharks	ocean bottom
Blue mussel (<i>Mytilus edulis</i>)	plankton	lobsters, crabs, dog whelks	intertidal
Northern sea star (<i>Asterias vulgaris</i>)	clams, mussels, whelks, periwinkles	seagulls	intertidal, subtidal
Green sea urchin (<i>Strongylocentrotus droebachiensis</i>)	algae	crabs, lobsters, fish	intertidal, subtidal
Atlantic cod (<i>Gadus morhua</i>)	krill, shrimp, fish, crabs	cod, seals	low to mid ocean
Winter flounder (<i>Pseudopleuronectes americanus</i>)	clams, worms	fish, seals, birds	ocean bottom
Atlantic mackerel (<i>Scomber scombrus</i>)	krill, fish	fish, seals	mid ocean

Preparation

Cut out the pictures of marine organisms (Appendix B) and paste to index cards to represent the biotic components of the marine community. Write the names of the abiotic components of an ecosystem on index cards (sun, soil, and water) and also marine plankton (**phytoplankton** and **zooplankton**).

Procedure

1. Have the students sit or arrange their desks in a circle. Each student will be given a picture of a marine organism.
2. Have the students look up their organism in a field guide to learn a little about it. They should be able to answer certain questions such as: 1) Where does it live 2) Does it eat? And if so, what?
3. In the circle, students will hold these pictures facing out so that others can see what ecosystem component they represent.
4. Ask students which parts of the ecosystem are *not* represented. [abiotic components such as sunlight, water, and nutrients]. These abiotic components are essential for all life. Pass out the index cards depicting these abiotic factors to a few of the students. Some students will have two index cards.
5. Ask students to describe a food web. All food webs are connected to the basic abiotic components of an ecosystem which are sunlight, water, and nutrients.
6. Explain that the class is going to depict a Gulf of Maine, marine food web.
7. Mention that some of the smallest, but most important members of the food web have been left out. What are they? [phytoplankton and zooplankton]. Pass out the plankton index cards.
8. To start the web, a student will begin by identifying their picture in ecological terms: Is it a producer or a consumer? What is its habitat or niche?
9. Then, the student will look around and identify another member of the marine ecosystem to which they are directly related. For example, a plant uses the energy of the sun, a primary consumer will eat a producer, etc.
10. Once the student identifies the related component, he/she will hold onto the end of the string while unraveling the ball of string, passing it to the student to whom he/she is "connected."
11. The second person will then proceed as the first student, until all students are part of the "web" made up of the string.
12. When all students are connected, introduce the idea of *disturbance* which is anything that upsets the balance of an ecosystem. These disturbances can be natural (e.g., storms, beaver dams, floods) or human-induced (e.g., acid rain, ocean dumping, fishing).
13. Present a particular disturbance and walk through the web again to see which components would be affected. What happens when the web begins to break down?

Discussion

1. Are humans part of the marine "Web of Life"? If so, what role do they play?
2. How does overfishing affect the web? Does this upset the ecological balance?
3. What happens when all of the finfish and shellfish are removed from the circle?
4. What role does aquaculture play in the "Web of Life"?

MAKING CONNECTIONS: ADDITIONAL ACTIVITIES AND EXTENSIONS

- Ecology & Aquaculture (The importance of ecology in aquaculture)

Using the six ecology statements listed previously, ask the students to determine how the “laws” of ecology relate to aquaculture production. This can be conducted in class, individually, or in cooperative learning groups; as a jigsaw, where each group is assigned to report on just one of the statements; or as an individual homework assignment.

- Field Trip to a Rocky Shore (Appendix C, D, and E)
- Conduct a field lab *Zonation Along A Rocky Shore* (Appendix C).
- Examine the survival adaptations of the plants and animals found along the rocky shore (Appendix D).
- Create a Maine coastal field guide using the pictures of the plants and animals from Appendix B and Appendix E.

GLOSSARY

Carp: Hardy, freshwater fish cultured throughout much of the world.

Competition: The simultaneous demand by two or more organisms for limited environmental resources, such as nutrients, living space, or light.

Ecosystem: An ecological system defined by the interactions of living and non-living components to form a discrete unit.

Energy: Capacity to do work.

Food Chain: The transfer of energy from the primary producers (green plants) through a series of organisms that eat and are eaten, assuming that each organism feeds on only one other type of organism.

Food Web: A diagram that represents the feeding relationships of organisms within an ecosystem, consisting of a series of food chains.

Habitat: Those plants, animals, and physical components of the environment that constitute the natural food, physical-chemical conditions, and shelter requirements of an organism.

Littoral (Intertidal) Zone: The part of the shore which is exposed at low tide and submerged at high tide.

Niche: The functional role of an organism in its environment.

Nutrients: Chemicals used for growth and maintenance of an organism.

Osprey: A bird of prey which feeds on fish.

Photosynthesis: The process by which green plants produce carbohydrates (food) from carbon dioxide, water, and the sun.

Phytoplankton: Tiny plants which make up the primary producers of aquatic ecosystems.

Predator: An animal which consumes another animal.

Prey: That animal which is consumed by a predator.

Primary Consumers: Consumers which feed on producers.

Resource: A component of an ecosystem such as nutrients, sunlight, water, or food that is required by an organism for its survival.

Secondary Consumers: Consumers which feed on other consumers.

Species: A group of organisms that resemble one another closely.

Zooplankton: Tiny animals which make up the primary consumers of aquatic ecosystems.

ADDITIONAL RESOURCES

- Andrews, William A. *Investigating Aquatic Ecosystems*. Scarborough, Ontario: Prentice-Hall Canada Inc., 1987.
- Booker, James and Dawn Grover. *Gulf of Maine Marine Coloring Book*. Augusta: Maine Department of Marine Resources, n.d.
- Coulombe, Deborah. *The Seaside Naturalist*. New York: Simon and Schuster-A Fireside Book, 1984.
- Jones, Elaine P. *A Teacher's Guide to Marine Life of the Gulf of Maine*. Augusta: Department of Marine Resources, 1993.
- Maine State Planning Office. *Charting Our Course: An Activity Guide for Grades 6-12 on Water Quality in the Gulf of Maine*. Augusta: Maine Coastal Program, 1995.
- Maine State Planning Office. *The Estuary Book*. Augusta: Maine Coastal Program, 1991.
- The Watercourse & Western Regional Environmental Education Council. *Project WET*. Boulder, CO, 1995.
- University of Maine Cooperative Extension. *Connections to the Sea: A 4-H Guide to Marine Education*. Orono, ME, 1990.
- Western Regional Environmental Education Council. *Project Wild Aquatic*. Boulder, CO, 1987.

Culturing Finfish

KEY CONCEPTS

Finfish account for 50% of global aquaculture production. In the United States, finfish accounts for 74% of total aquaculture production. In order to successfully culture finfish, we must have a good understanding of the biology, ecology, anatomy, and life cycle of the species in question. Catfish are, by far, the most commonly cultured fish in the United States (47%). These warmwater species are cultured in freshwater ponds in southern areas of the country. In cool, northern waters, the most commonly cultured finfish are salmonids (trout and salmon). Currently in Maine, salmon, steelhead trout and char are the only finfish cultured for commercial sale. However, many aquaculturists are learning how to commercially grow other fish such as cod, haddock and flounder.

LESSON OVERVIEW

Students will learn about culturing finfish in Maine. They will learn how to use a dichotomous key to identify several fish found in Maine. By counting growth rings on scales, students will determine the age of fish. Students will become familiar with the external and internal anatomy of a bony fish through dissection.

LEARNING OBJECTIVES

After completing this chapter, the student will be able to:

- List the major finfish cultured in Maine.
- Distinguish between jawless fish, cartilaginous fish, and bony fish.
- Describe how fish are classified.
- Describe the basic physiology of the fish.
- Describe the life history of the Atlantic salmon.
- Determine the age of a fish by examining scales.
- Identify the internal and external structure of finfish.
- Determine the function of various internal and external features of finfish.
- Demonstrate effective use of a microscope.
- Demonstrate dissection skills.

LEARNING RESULTS

KEYING OUT FISH

A. **Classifying Life Forms:** Students will understand that there are similarities within the diversity of all living things.

2. Describe similarities and differences among organisms within each taxonomic level.

J. Inquiry and Problem Solving

1. Make accurate observations using appropriate tools and units of measure.

AGING FISH

J. **Inquiry and Problem Solving:** Students will apply inquiry and problem solving approaches in science and technology.

1. Make accurate observations using appropriate tools and units of measure.

2. Verify, evaluate, and use results in a purposeful way.

BONY FISH DISSECTION

J. Inquiry and Problem Solving

1. Make accurate observations using appropriate tools and units of measure.
2. Verify, evaluate, and use results in a purposeful way.

K. Scientific Reasoning

3. Develop generalizations based on observations.

MATERIALS

Photocopies of the following student handouts: *Culturing Finfish in Maine*, *Key Out These Fish*, *Bony Fish Dissection*, *Bony Fish Dissection Diagram*, *Gill Diagrams*, *Scale Types and Growth Rings*, *Generalized Bony Fish External Anatomy*; hand lens or dissecting microscope, compound microscope slides, coverslips, various species of fish and scales provided by teacher, metric ruler, projector, microprojector or slide projector, plastic sheeting, empty slide, newspaper or table covering material, disposable latex/rubber gloves, tweezers/forceps, scissors, scalpel, eye dropper/pipette, commercial quick blood smear stain, alcohol or bunsen burner.

BACKGROUND

Classification

Fish are divided into three groups:

1. Jawless fish (*Agnatha*) (e.g., hagfish and lampreys)
2. Cartilaginous fish (*Chondrichthyes*) (e.g., sharks, skates, rays, and chimeras)
3. Bony fish (*Osteichthyes*) (e.g., lobe-finned fish, lungfish, and ray-finned fish)

For the purpose of aquaculture, we are primarily concerned with the bony fish, and more specifically, the ray-finned fish. There are over 20,000 species of ray-finned fish, an extremely diverse group found in fresh, salt and brackish waters. Most ray-finned fish, such as salmon, trout and carp, have protective scales covering their skin. Catfish, however, do not. All ray-finned fish have gills which are used to remove oxygen from the water and release carbon dioxide. The gills are usually covered by a plate-like structure called the *operculum*.

Fish produce mucous through their skin which makes them feel slimy and serves a variety of functions. It allows the fish to move smoothly and quickly through the water by reducing friction, it helps make the skin waterproof, and it protects the fish from bacteria and other small organisms which can cause infections.

All bony fish have fins, although the number, shape, and purpose of those fins vary greatly. Fish are equipped with teeth which help them catch their prey, but they don't use them for chewing; they must gulp their food down whole. Fish are cold-blooded which means their body remains the same temperature as their surroundings. The bony or ray-finned fish are an extremely diverse group made up of many different shapes, sizes, and colors.

Female fish lay eggs, which are fertilized with sperm from the males. Some fish build "nests" along the bottom which they "guard" until the eggs hatch. A few fish, including some tilapia, guard their eggs in their mouth; they are called mouth brooders. Fish may lay thousands of eggs, but usually only one out of 100 survives to become an adult fish. Most eggs and young are eaten by other aquatic animals, thus contributing to the food chain. When fish hatch, they are equipped with a *yolk sac* which provides them with nourishment for the first couple of days, after which time the yolk sac becomes absorbed and fish must fend for themselves.

Physiology of the fish (the study of body functions)

All animals have nine body systems:

1. Skeletal
2. Muscular
3. Digestive
4. Excretory
5. Respiratory
6. Circulatory
7. Nervous
8. Sensory
9. Reproductive

In aquatic animals, such as fish, these systems are adapted to a water environment.

1. **Skeletal:** Fish have an internal or *endoskeleton* which provides shape, support, and protection for internal organs and muscles which attach to the skeleton.
2. **Muscular:** By contracting and releasing muscles, fish can move through the water (locomotion), capture food, pass water over their gills for oxygen, and eliminate waste.
3. **Digestive System:** Digestion is a process which converts food into a usable form for growth, maintenance, and reproduction. A fish's digestive system differs depending on whether it is an herbivore, carnivore, or omnivore. The digestive system usually consists of a mouth, esophagus, stomach, intestines, and anus.
4. **Excretory System:** The excretory system eliminates waste from the body and usually consists of the gills, kidneys, urinary ducts, bladder, and opening.
5. **Respiratory System:** Gills are the respiratory organs of the fish. Water is pumped over the gills and dissolved oxygen present in the water diffuses into the blood stream. This oxygen is delivered to the tissues and cells of the body and exchanged for carbon dioxide, which is then expelled as a waste product through the gills and into the water.
6. **Circulatory System:** The circulatory system includes the heart, veins, and arteries and is responsible for circulating blood throughout the body. Oxygenated blood travels to the cells and tissues where it is exchanged for carbon dioxide. This de-oxygenated blood travels back to the gills, is released into the water, and is replaced with oxygen.
7. **Nervous System:** The fish's nervous system consists of a well-developed brain, spinal column, nerve fibers and sensory receptors. Through electrical-chemical impulses, the nervous system supplies the fish with information about its internal and external environment.
8. **Sensory System:** The sensory system relays information through the nervous system using the five senses: sight, smell, touch, taste, and hearing. The *lateral line* is an external sensory organ which runs down the length of the fish and helps it maintain balance and position in the water. Some fish, like catfish, have **barbels** which help them feel around the bottom for food.
9. **Reproductive System:** Fish reproduce sexually to create offspring. Males have testes which produce sperm and females have ovaries which produce eggs.

STUDENT HANDOUT

Culturing Finfish in Maine

Culturing Salmon and Steelhead Trout

The most popular fish to culture in the Gulf of Maine is the Atlantic salmon. Maine aquaculturists have been raising salmon since the 1970s. Hatcheries throughout the state produce 3.5 million fish each year for net-pen salmon farming operations along the coast.

While private industry continues to farm Atlantic salmon for profit, there are also public hatchery programs aimed at restocking Maine's rivers and streams. Native salmon populations have been in decline for some time. Since there is concern that the Atlantic salmon may disappear from Maine's rivers completely, the federal and state government has been trying to protect the salmon through stricter fishing regulations, improvement or restoration of salmon river habitat, and hatchery stocking programs.

The Atlantic salmon is an **anadromous** species which means they are born in fresh water, spend most of their life at sea, and return to fresh water to **spawn** or produce young. In the wild, most of an adult salmon's life is spent in the ocean. During the spring of the fourth or fifth year, the adult fish will return to the river where it was born in order to spawn.

Life Cycle of the Atlantic Salmon

In salmon and steelhead farms, some adult fish are kept for **broodstock**. These fish supply the eggs and the sperm to produce all the hatchery fish. Spawning occurs between mid-November and mid-December. A 12-pound female fish produces an average of 10,000 eggs each season. These eggs are collected and **fertilized** with sperm from the males by mixing the two together. The fertilized eggs are then **incubated** at a freshwater **hatchery**. The eggs hatch and eventually develop into free-swimming **fry**. After the **yolk sac** is absorbed, the fish begin to eat food on their own.

During the first year of life, fish develop vertical stripes on their sides. They are now called **parr**. For the first 18 months of their life cycle in the hatchery, **parr** are **graded**, vaccinated against diseases, and their health and growth is monitored. After two to three years in fresh water, young salmon undergo major changes that enable them to live in salt water. Their kidneys adapt to excrete salt, rather than retain it, and their skin becomes silvery so the fish will be less visible to predators in the ocean. Changes also occur in the eyes, blood plasma, musculature, and fat. This whole process is called *smoltification*. The **smolts**, roughly five inches long, are transferred to floating pens in the sea, typically between mid-April and mid-May.

The steelhead trout, also called the sea run rainbow trout, belongs to the same family (the **salmonids**) as the Atlantic salmon. The steelhead has been referred to as the saltwater version of the rainbow trout. The life cycle of the steelhead is essentially the same as the Atlantic salmon, except that the steelhead does not go through true smoltification. In the wild, both Atlantic salmon and steelhead trout return to fresh water to spawn. The steelhead looks similar to the Atlantic salmon, but usually has an iridescent sheen; hence the name "rainbow." This rainbow sheen becomes brighter when the steelhead returns to fresh water to spawn.

Salmon Farming

Young salmon are raised in freshwater hatcheries. When they undergo smoltification, they are then transferred to salt water salmon farms. In these grow-out facilities, salmon are housed in net pens which are generally 20 feet deep. These large pen systems, held in place with moorings,

may cover several acres of surface water. In the pens, fish are fed pellets of fish meal, vitamins, and minerals. To prevent the spread of disease, fish are inoculated or antibiotics added to the fish feed. After about two years in the pens, fish grow from smolts weighing 3 to 5 ounces (80-120 grams) to fish with a market weight of 6 to 12 pounds. A farming operation with 2-1/2 acres of net pens can produce about 50,000 fish each year for market. When the fish reach an appropriate size, they are harvested, cleaned, and shipped to wholesale and retail markets.

Eight commercial freshwater hatcheries in Maine produced about 3 million young salmon and 100,000 steelhead in 1995. There are 30 saltwater grow-out sites, located primarily in Washington and Hancock counties, where excellent water quality, protected bays, water temperatures of 0 to 15°C (32-59°F), strong currents, and high tides provide ideal conditions for raising salmon. In 1995, fish farming generated more than \$53 million in gross sales revenue, and the salmonid aquaculture industry has brought much needed aid to economically depressed communities. Increasingly, fishermen who depend on wild fish stocks for their livelihood are considering putting their skills to work in aquaculture to supplement their incomes.

Another economic benefit of salmon and steelhead trout farming is the increase in the number of family-owned smoke houses, where the fish are processed for a gourmet market. Furthermore, a health-conscious public creates a demand for salmon and steelhead, which are excellent sources of protein, omega-3 fatty acids, and vitamins A, B, D, and E. These fish species are also low in sodium, rich in potassium, and are natural sources of selenium, iodine, and fluorine.

Salmon farming depends on, and demands, a clean environment. One of the largest dangers to salmon farming is industrial and municipal waste which enters the marine environment. This pollution may contain hazardous chemicals, heavy metals, and untreated sewage which then make eating fish or shellfish hazardous to humans. In order to protect the salmon farms, pollution inputs from industrial or municipal sources must be very carefully monitored and regulated. Protecting the salmon pens from pollution, can help protect the marine environment as a whole.

Culturing Other Finfish in Maine

With the decline in wild groundfish populations, there is considerable interest in developing efficient techniques for raising cod, halibut, and haddock on fish farms. Researchers at the University of Maine recently began studying both the nutritional needs of larval cod and haddock, and the type of food to maximize healthy growth in the early stages of these fish. Atlantic Aquafarms in Franklin and the Maine Hatchery Technology Association on Swan's Island are experimenting with different ways of hatching and raising cod and haddock on a commercial scale. Some of the young fish will be used for restoring the natural groundfish populations in the waters offshore; the rest will be raised in pens until they are market size. Both projects are good examples of cooperation between aquaculturists and traditional fishermen.

High in demand, low in supply, halibut (*Hippoglossus hippoglossus*) could be a good candidate for aquaculture. Halibut is more resistant to **superchill** than salmon. Maine aquaculturists have successfully captured young halibut and are rearing them for future broodstock for the Maine aquaculture industry.

Halibut (which can achieve a weight of more than 100 pounds in the wild) present special challenges for pen culture. As an experiment, young fish that weighed from seven to 10 pounds were caught by longline fishermen and donated to the broodstock project. Raised in pens, these fish grew three times faster in captivity than in nature. Now researchers are testing new "Malloch-style" cages, made of tightly drawn nylon mesh, and designed by growers at the Marine Technology Center in Eastport. By the fall of 1996, 27 fish were held at Maine Salmon Company's Shackford

Head lease site in Eastport while researchers waited for them to mature. Scientists expect to study broodstock management, experiment with halibut egg incubation, and continue to investigate the growth patterns and larval feeding habits of halibut.

SALMON LIFE CYCLE

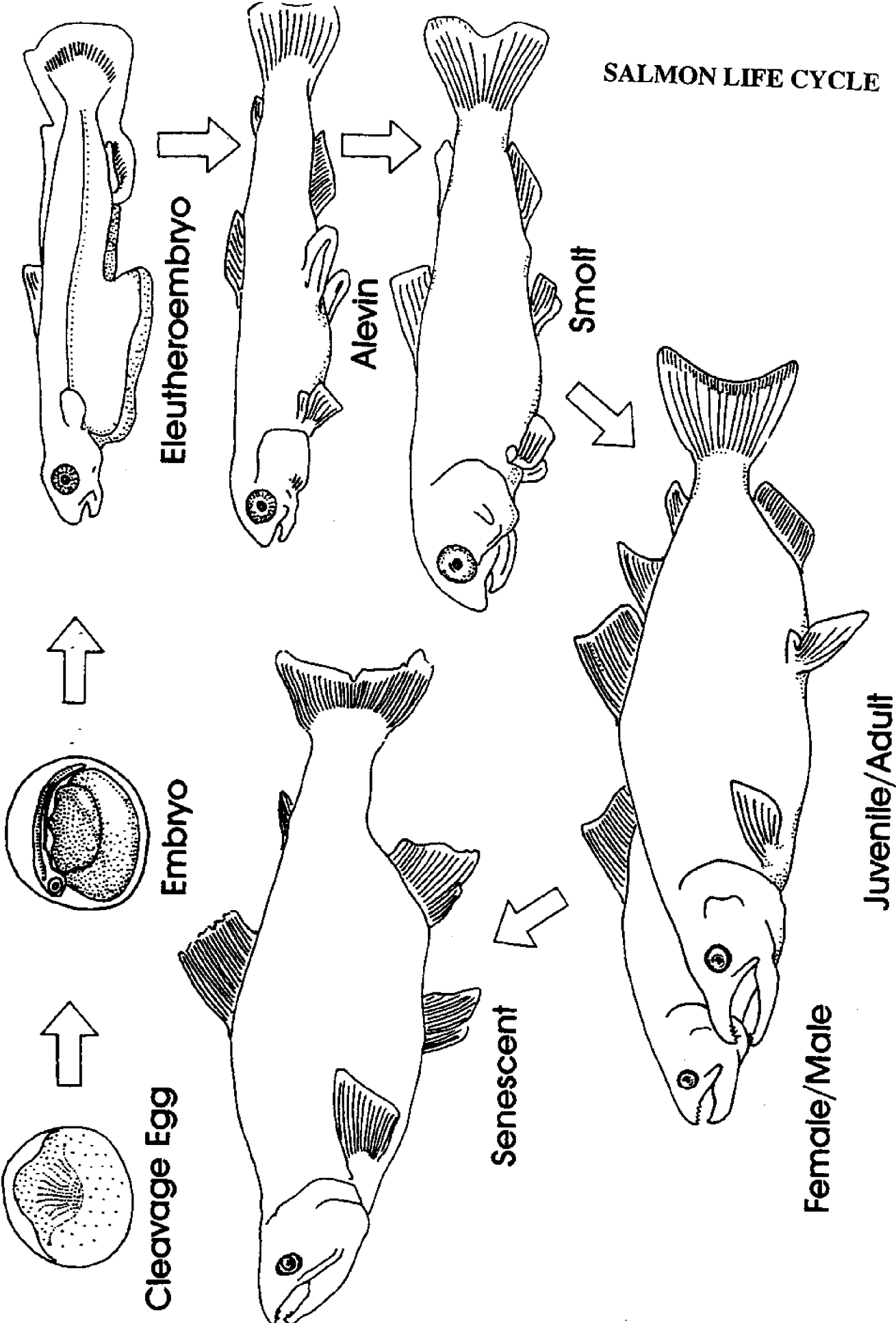

Successive developmental stages of the salmon.

ACTIVITY 1: KEYING OUT FISH

Information

A fish key is a series of questions or statements that may be asked about the characteristics of a fish. If you do not know the scientific name (genus and species) of a fish, you can observe the fish and answer the questions in the key to find the scientific name. At the end of each question that pertains to your particular fish is a number directing you to the next question. When you have answered enough questions, you eventually find the scientific name of your fish.

Procedure

Choose a fish and carefully answer each question, proceeding through the key. If a question is answered incorrectly, you will not obtain the correct scientific name. A key is provided and may be copied and handed out to your class.

Answers to *Key These Fish* Handout

1) smelt 2) haddock 3) American eel 4) winter flounder 5) ocean sunfish 6) white hake
7) hammerhead shark 8) wolffish 9) sea lamprey 10) Atlantic halibut 11) alewife 12) bluefin tuna
13) American pollock 14) spiny dogfish 15) Atlantic cod 16) Atlantic mackerel

FISH KEY

Sample answers for
hammerhead shark

1. a. Does the fish have a body like a snake? 2 (no)
b. Does the fish not have a body like a snake? 3 (yes)
2. a. Does the fish have a jaw? *Anguilla rostrata* (American eel)
b. Does the fish not have a jaw? *Petromyzon marinus* (lampreys and hagfish)
3. a. Does the fish have eyes on the same side and a flattened body? 4 (no)
b. Does the fish not have eyes on the same side and no flattened body? 5 (yes)
4. a. Does the fish have a forked tail? *Hippoglossus hippoglossus* (Atlantic halibut)
b. Does the fish not have a forked tail? *Pseudopleuronectes americanus* (winter flounder)
5. a. Does the fish have fleshy fins (without rays)? 6 (yes)
b. Does the fish have fins with rays? 7 (no)
6. a. Does the fish have a pointed head? *Squalus acanthias* (spiny dogfish shark) (no)
b. Does the fish not have a pointed head? *Sphyrna lewini* (scalloped hammerhead shark) (yes)
7. a. Is the fish body full moon-shaped with a little caudal fin? *Mola mola* (ocean sunfish)
b. Is the fish body not distinctly moon-shaped and has a highly visible larger caudal fin? 8
8. a. Is the fish club-shaped like a baseball bat? *Anarhichas lupus* (Atlantic wolffish)
b. Is the fish body not club-shaped like a baseball bat? 9
9. a. Is there evidence of a chin barbel? 10
b. Does the fish have no chin barbels? 13
10. a. Is the caudal fin not notched or only slightly (just barely) notched? 11
b. Is the tail decidedly notched? 12
11. a. Does the fish have three distinct dorsal fins (top side)? *Gadus morhua* (Atlantic cod)
b. Does the fish have two distinct dorsal fins? *Urophycis tenuis* (white hake)

12. a. Does the lower jaw extend beyond the upper jaw? **Pollachius virens**
(**American pollock**)
b. Does the lower jaw not extend beyond the upper jaw? **Melanogrammus**
anglefinus (**haddock**)
13. a. Does the fish have finlets (small fins like growth between tail and dorsal
and anal fin)? **14**
b. Does the fish not have finlets? **15**
14. a. Are the dorsal fins distinctly separated? **Scomber scombrus** (**Atlantic**
mackerel)
b. Are the dorsal fins not separated distinctly? **Thunnus thynnus** (**bluefin**
tuna)
15. a. Does the fish have a small adipose fin (small fleshy fin between the caudal
and dorsal fin)? **Osmerus mordax** (**smelt**)
b. Does the fish not have a small adipose fin? **Pamolobus pseudoharegus**
(**alewife**)

Key Out These Fish

1

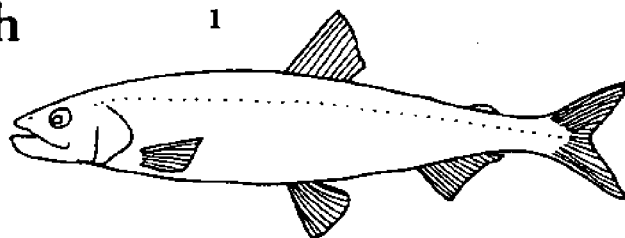

2

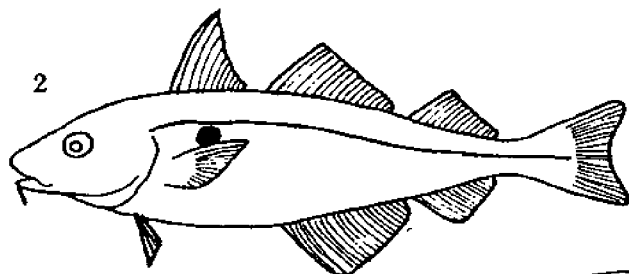

3

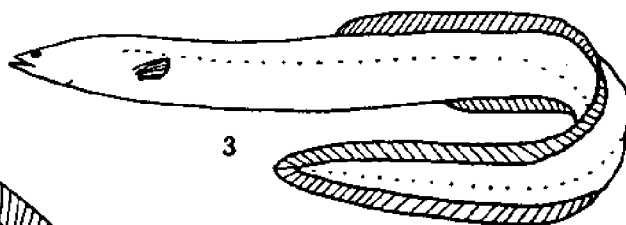

4

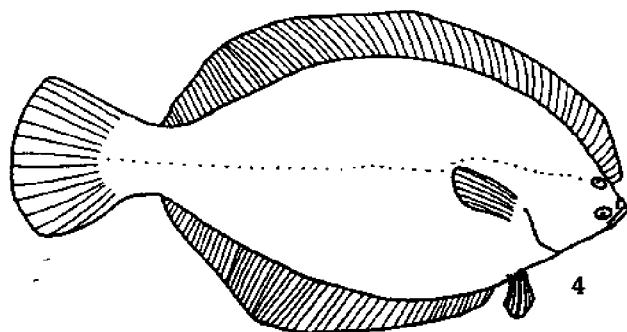

5

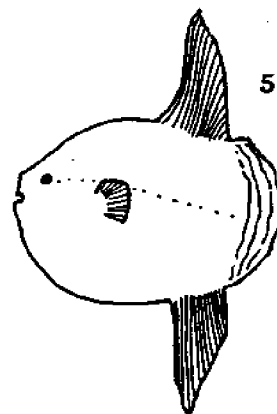

6

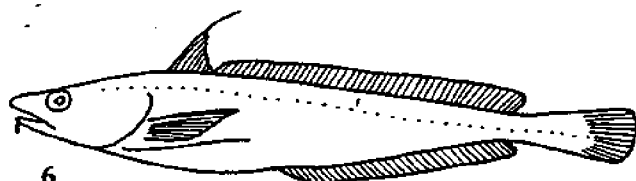

7

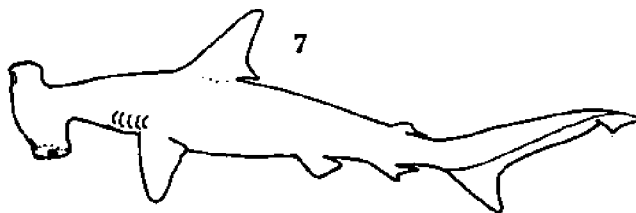

8

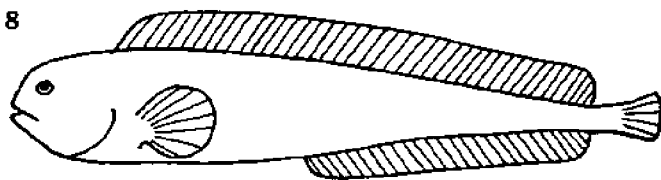

Key Out These Fish

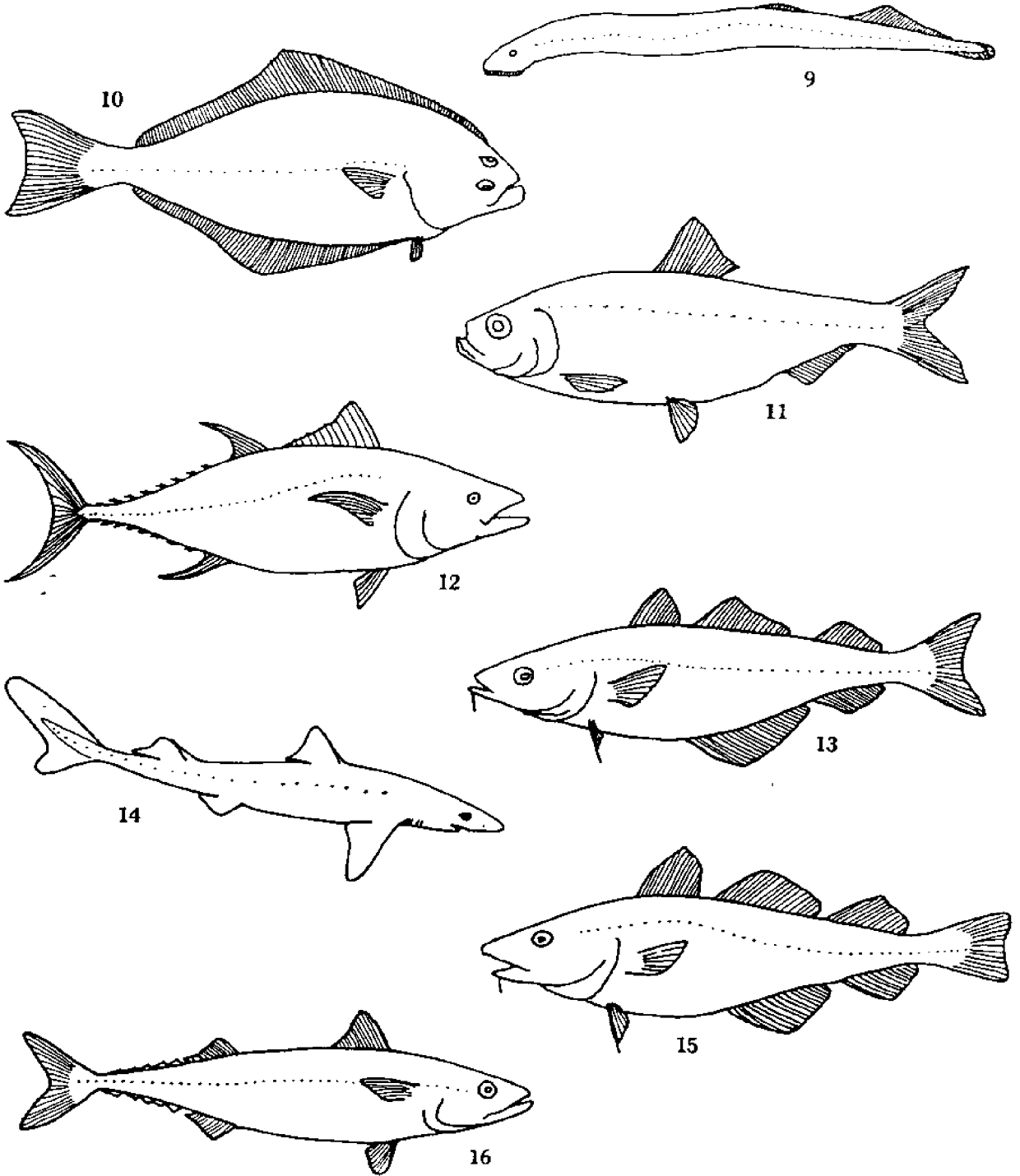

ACTIVITY 2: AGING FISH

Information

Determining the age of fish is very important for fishery biologists and aquaculturists. By examining scales, it is possible to determine an age profile of your present fish population and make predictions for the future. Knowledge of the age structure of a fish population is important for management practices and conservation efforts.

Given adequate food and space, fish will continually grow. In this case the oldest fish would be the largest, but in nature, conditions are less than ideal and fish grow at varying rates. Food, space and other life requirements are not equally distributed in the environment, and some fish are more hardy and grow faster than others.

There are a number of methods to calculate the age of fish. Aging fish by scale counts is the most widespread and straightforward method and can be conducted on live specimens without harming the individual. The limitations of this method is that accuracy depends on the interpretive ability of the examiner and the distinctiveness of the annual layers. Scales grow as the fish grows, producing growth layers which have a ring-like appearance. The scale and other hard parts of the fish grow faster during the heavy feeding months of the summer and slow down during bad feeding seasons, usually winter. When the growth subsides, the rings are closer together and appear darker, when observed under low microscopic magnification (20-40X). Each of these darker rings is an *annulus* and usually demarks one year's growth.

The age of the fish can be roughly determined by counting the rings starting with the clear area of the center called the focus or core. The focus represents the original scale of the young fish. In order to determine the age of fish by studying the scale structure, several terms should be explained:

- **Annulus:** The annual mark or zone on fish scales which is formed once a year.
- **Focus:** The small, clear area near the center of the scale which represents the original scale of the young fish.
- **Ctenoid Scale:** The scale of a bony fish (teleost) which possesses small sharp spines (ctenii).
- **Cycloid Scale:** The scale of a bony fish without spines.

There are variations of these scales. The spines of ctenii and the position of the focus varies with each species of fish. The annulus is recognized in one of the following ways: 1) "crossing over" where the onset of fall or winter causes several ridges or *circuli* to flare outward and end on the side of the scale, rather than circle the focus; 2) "discontinuous circuli" where the individual circuli do not grow together in a complete line because the scale stops growing and 3) extreme crowding of the circuli which occurs first, prior to resumption of growth.

Preparation

Select fish with large scales. These include fish such as herring, alewife, bass, perch, haddock, cunner, salmon, anchovy, and silversides. Other swift-swimming fish such as the mackerel and tuna have reduced scales to enhance streamlining. The scales of common eels (*Anguilla*) are microscopic or not present. You may obtain some of the above fish from a local fish market, a seafood processing plant, or a local fisherman. Fully-formed scales from each specimen should be selected. When a scale is lost, the regenerated scale does not form the old rings. Also, a false annual ring is produced by females just prior to spawning as reabsorption occurs. In addition, it is

difficult to age hatchery fish using this method. Hatchery fish undergo rapid, even growth within controlled environments. Their scales will not have the annual dense groupings found on scales of fish that experience seasonal food deprivation.

To provide uniformity to this procedure, biologists usually select scales from a specific spot on a fish. Follow the back edge of the dorsal fin down towards the lateral line; remove the second scale just above the lateral line. After the scales are selected and removed, they may be stored for later use by placing them in an envelope or by pressing them between pieces of paper. The scales have their own cement called mucus. If possible, the paper that the scale is on should be labeled with the following information: type of species, weight, length, place, sex, and date. A useful way to examine scales is to place them between two layers of thin clear plastic and mount them in a 35-millimeter (mm) slide blank. Scales are magnified by projecting them with an ordinary 35-mm slide projector. This method facilitates storing and cataloging and can be done by the whole class at once. Scales may also be examined under the stereoscope at 2040X. Detailed examinations of parts of the scales may also be of interest. A compound microscope with 50-100X objectives would be of some use, especially for smaller scales if large ones are not available.

Collecting scales from a large number of different species of fish shows the variety of size and the difficulty of age analysis. Start out with some of the easier specimens first, such as herring or haddock. A comparison of bony fish scales to the scales of sharks would also be of interest. Sharks have a more primitive *placoid* type scale, which does not detach easily. The scale, which is very tiny, gives the skin a sandpaper-like texture. Other types of scales include those of the gar and the Atlantic sturgeon which have *ganoid* scales. Ganoid scales also do not detach easily. Large and pyramid-shaped, they give the skin an armour-like appearance.

STUDENT HANDOUT

Generalized Bony Fish External Anatomy

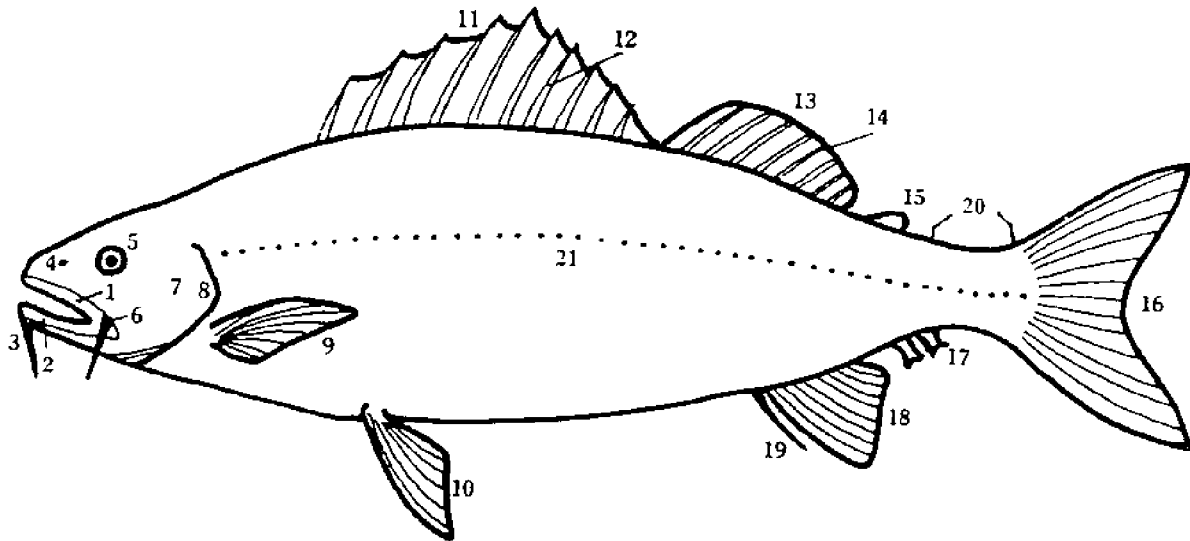

- | | |
|--|--|
| <ul style="list-style-type: none"> 1. Maxilla and premaxilla (Upper jaw) 2. Mandible (Lower jaw) 3. Barbel 4. Nostril 5. Eye 6. Maxillary barbel 7. Cheek 8. Operculum (gill cover) 9. Pectoral fin 10. Pelvic fin | <ul style="list-style-type: none"> 11. Spiny dorsal fin (first dorsal) 12. Dorsal spine 13. Soft rayed dorsal fin (second dorsal) 14. Soft ray (fin ray) 15. Adipose fin 16. Caudal fin (tail fin) 17. Finlets 18. Anal fin 19. Anal spine 20. Caudal peduncle 21. Lateral line |
|--|--|

Bony Fish Scale Types and Growth Rings

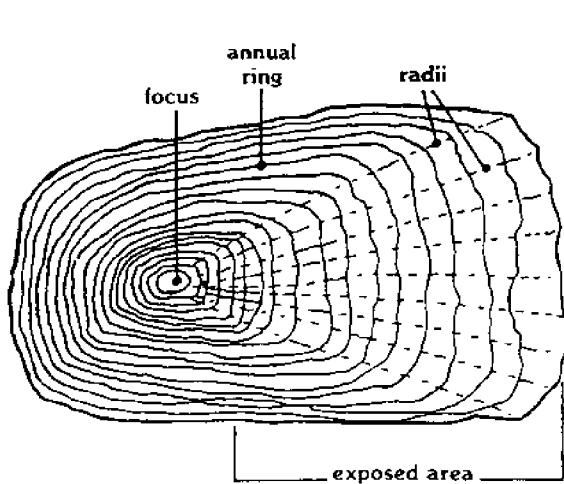

Cycloid Scale
(from cod)

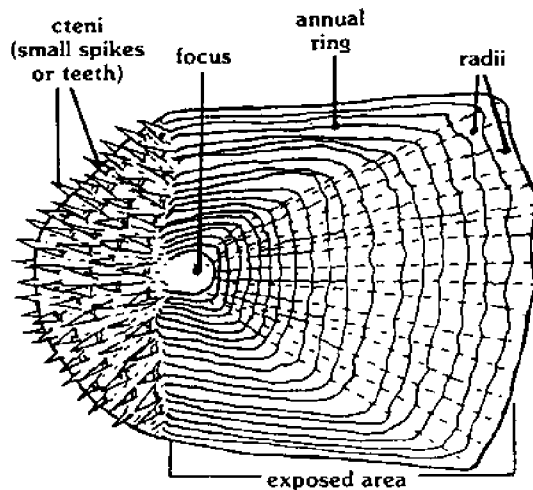

Ctenoid Scale
(from striped bass)



LAB HANDOUT

Determining the Age of Fish Through Observation of Scales

Information

With increasing demands on fish stocks around the world, it has become very important to know the age composition of each type of fish. Such knowledge about the amount of growth gained each year, the life span of fish, and the age structure of the population, enables us to harvest fish crops more efficiently and to enact conservation measures effectively. We will age fish by counting the annual growth rings deposited on the scales of fish.

Terms to know

- **Annulus:** The annual mark or zone on fish scales which is formed once a year.
- **Focus:** The small, clear area near the center of the scale which represents the original scale of the young fish.
- **Ctenoid Scale:** The scale of a bony fish (*teleost*) which possesses small sharp spines (*ctenii*).
- **Cycloid Scale:** The scale of a bony fish without spines.

Materials

Hand lens or dissecting microscope, compound microscope slides, various species of fish or scales provided by teacher, metric ruler, projector, microprojector or slide projector, plastic sheeting, and empty slide (if demonstrations are desired)

Procedure

1. Remove a scale from several areas of each specimen. Using a hand lens or microscope and the *Scale Types and Growth Rings* handout, determine if scales are cycloid or ctenoid.
2. If the scale is ctenoid, remove further scales around the area of the pectoral fin. Cycloid scales should be taken from an area between the dorsal fin and the lateral line. Remove three scales from the indicated area of each specimen.
3. Make a wet mount of the scales or place them between two glass slides for microscopic observation. Use both a compound microscope and a stereoscope.

Observations

Make illustrations of the general features of the scale noting: annuli, focus, circuli, and ctenii (when present). Determine the distance between annuli on the scale by using a metric ruler. To determine the age, each scale should be counted twice, at different times, to arrive at an accurate interpretation. Count one year of growth for each annulus.

Discussion

Can you differentiate between summer growth and winter growth? How? Each scale tells a story about the life history of that particular fish. Choose a scale and describe its life history.

Limitations and Sources of Error

This could result in incorrect reading of scales. Some fish show no definite annuli. Other errors might result in the use of imperfect scale or scales that have been rejuvenated. Errors in age determination increase with the age of the fish. Errors may also be made in determining the location of the first annulus.

ACTIVITY 3: BONY FISH DISSECTION

Preparation:

If possible, select several different specimens and compare their external features. The fish may be fresh or marine, as both have the same anatomical features. A diagram of the internal and general external anatomy of a typical bony fish is provided. Photocopy and distribute copies of the lab handouts *Bony Fish Dissection Diagram*, *Generalized Bony Fish External Anatomy*, and *Gill Diagrams*. More detailed anatomical figures are available in marine science lab manuals.

STUDENT HANDOUT

Bony Fish Dissection Diagram

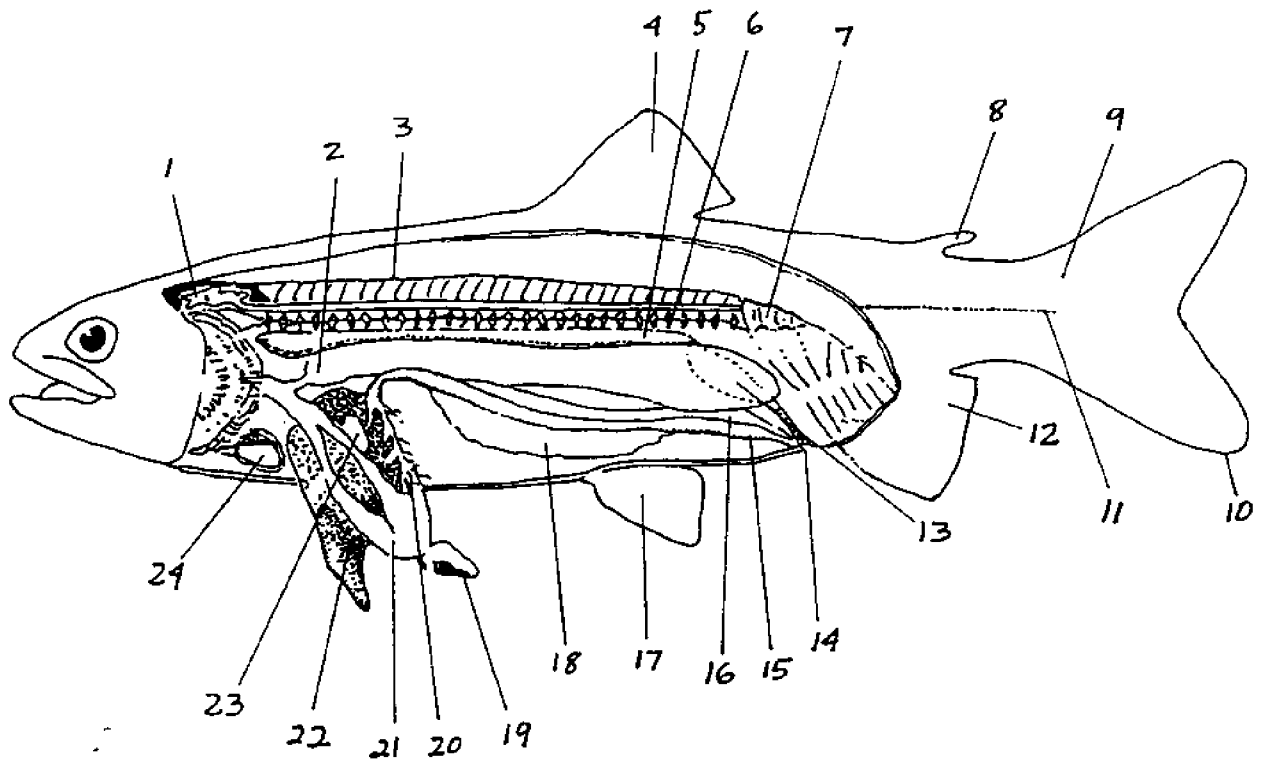

- | | |
|--------------------|---------------------|
| 1. Brain | 13. Urinary bladder |
| 2. Swim bladder | 14. Anus |
| 3. Neural spine | 15. Colon |
| 4. Dorsal fin | 16. Gonad |
| 5. Kidney | 17. Pelvic fin |
| 6. Spinal cord | 18. Adipose tissue |
| 7. Vertebrae | 19. Spleen |
| 8. Adipose fin | 20. Pyloric caeca |
| 9. Caudal peduncle | 21. Stomach |
| 10. Caudal fin | 22. Liver |
| 11. Lateral line | 23. Gall bladder |
| 12. Anal fin | 24. Heart |

STUDENT HANDOUT

Gill Diagrams

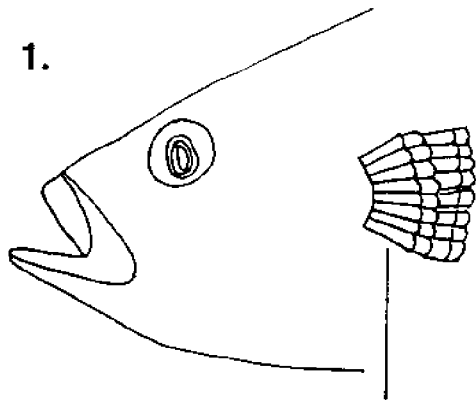

Gill filaments are stacked and layered for increased surface area.

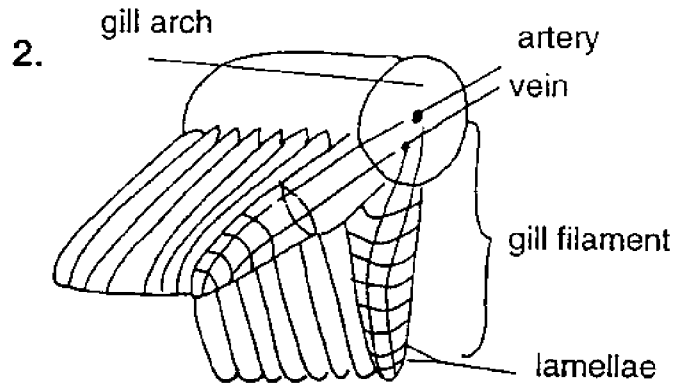

The major parts of the gills include the bony gill arch. The major blood vessels run through the gill arch and along the gill filament. Each filament contains several disc-shaped lamella.

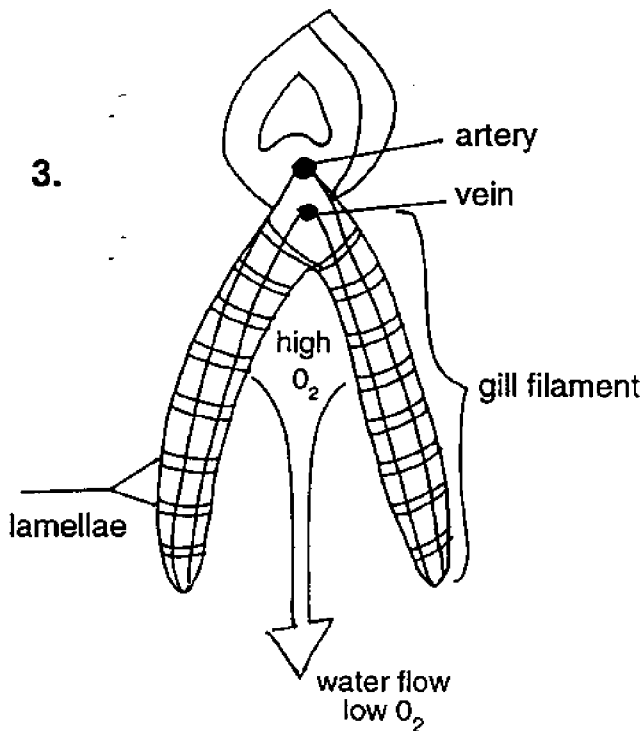

The lamella (folds of tissue) contain the smaller branches of blood vessels known as capillaries. The exchange of gases occurs in the capillaries.

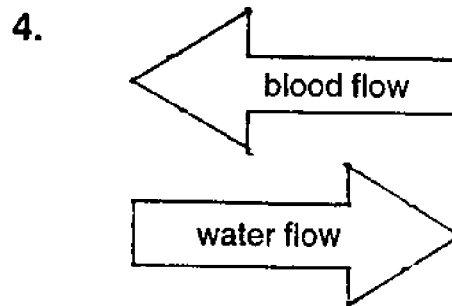

The fish maintains a one-way flow of water through the gills by taking water into the mouth and passing it out through the gill slit or operculum. The water flows over the gills. Specifically, the gill filaments deflect the water so it will flow across the lamella. The blood flows in the opposite direction. The water and blood flow in counter directions across the lamella. This counter current flow enhances the diffusion of oxygen into the blood.

STUDENT HANDOUT

Bony Fish Dissection

Instructions

Carefully read through the following procedures and record observations accordingly.

Procedures

External Anatomy

Shape

1. Commonly, a fish's body is torpedo-shaped (fusiform) and slightly ovoid in cross-section. However, there are many interesting departures from this idealized case. These range from globe shapes (puffers-globiform) through serpentine (American eels-anguilliform) to thread-like forms (snipes). A flatfish like a flounder is laterally compressed or flattened from the sides, whereas a skate is dorso-ventrally compressed or flattened from the top. *What is the shape of the fish(s) you are dissecting?*

Body Covering

2. Many fish have thick skins which are continuous with the lining of all the body openings. Mucous cells provide a coating which is both protective and effective in streamlining the fish for swimming. *Does your specimen(s) have a very tough skin? Does it feel slimy?*
3. Scales are usually imbedded in the skin. They may be small or very large. The types of scales (ganoid, cycloid, or ctenoid) serve as characteristics of major bony fish groups. The types of scales and the number of scale rows along or around the body aid in identification. *What type of scales does your specimen(s) have? Are they small or large?*

Appendages

4. The appendages of fish include the various fins and the *cirrhi* (fleshy projections). Fins are categorized as median or paired. The dorsal (top) fins show much variation. They may be continuous, partially divided, or completely divided into separate parts. The dorsal fin may also consist of either spines (soft or hard), rays, or both. Spines usually appear transparent, hard, and sharp at the ends. Rays are soft and appear segmented when held to the light or when viewed under a low-powered stereoscope. The rays may also branch out at the end. *What type of dorsal fin(s) does your specimen(s) have? Does it have rays, spines, or both? What advantage is there to having spines or soft rays?*

6. Other median fins include the tail (caudal fin) and the anal fin (just behind the vent on the lower side). The trout or salmon-like forms have a fatty adipose fin. Fins also may be reduced to a few disconnected spines as in the stickleback. *What function do you think the caudal fin serves?*

7. Pectoral fins may vary also. They may be enlarged as in the sculpin, sea raven, or flying fish, or more regular in shape, as in the trout and flounder. *What function do you think the pectoral fins serve?*

8. Pelvic fins vary in shape and position. Their support comes internally from the pelvic girdle. Most soft-rayed fish have pelvics located abdominally, as in salmonids. They may be located below the pectorals, or they may be under the throat (jugular). Some pelvics are modified, as in the shark and skate, to form claspers used in reproduction. *Where are the pelvic fins on your fish? What function do you suppose they serve?*

Internal Anatomy

9. Using a scalpel or strong scissors, carefully cut open the belly cavity, starting at the anal vent and proceeding up to the pectoral fins. For a better view, remove a portion of the body wall by starting again at the anal vent and cutting an arch-shaped line to the pectoral fins. *Use the internal anatomy diagram to help identify the structures.*

10. Take the gill cover, called the *operculum*, off the left side of the fish and observe the gills. If the specimen is fresh, note the red color produced by blood capillaries. ***Sketch the gill structure.***

11. Identify the major internal organs. ***Make a diagram showing the route of the blood from the heart (two-chambered) to the gills.***

12. Study the digestive tract. Make an incision through the small intestines and a small cross-section. Examine the internal surface area. ***What is the color of the lining of the digestive cavity?*** This lining is called the *peritoneum*. If it is white, the fish is generally a carnivore. Black indicates an herbivore.

13. Observe the swim bladder which is found under the vertebral column and kidneys. Note that it connects to the esophagus. This flotation device is unique among the bony fish and is very important for maintaining buoyancy. ***Can you express any air from the swim bladder?***

14. Cut into the musculature midway along the body. ***Are all the muscles white or are some red? What is the approximate ratio of red to white muscle tissue in this region of the body? What do you think the significance of red muscle cells is for a swimming animal?***

15. Choose an organ like the heart, liver, kidney, or spleen and cut a portion from it. Use forceps to blot the cut surface of the organ on a microscope slide. Allow slide to air dry and then quickly pass the slide once or twice through an alcohol burner flame. (This will fix or stick the blot to the slide). Stain with a commercial quick blood stain for one minute. Rinse slide in tap water and allow to air dry. View under a compound microscope at 40X or 100X. *Draw a diagram of what you see. Label the red blood cells and the white blood cells.*

MAKING CONNECTIONS: ADDITIONAL ACTIVITIES AND EXTENSIONS

- Culture Candidates

Divide the class into cooperative learning groups. Using the *ABC Fish of the Gulf of Maine* (obtained from Maine Department of Marine Resources) and the *NOAA Status of the Fishery Resources off the Northeastern United States* (obtained from Woods Hole Oceanographic Institute), identify which species are currently being overfished. Divide the class into cooperative learning groups and have them choose one of the fish (principal groundfish or flounder) to research. Groups should research the past and current status of their species, and its biology, ecology, and potential for culture. Groups will report their findings to the class.

- Cleaning and Dressing Fish

Perhaps you will have the opportunity to go on a class fishing trip, or to obtain fish for the dissection which are suitable for cooking. For information on cleaning and dressing fish, refer to Appendix F.

GLOSSARY

Adipose: Fat tissue.

Anadromous: A species which leaves the sea to migrate up freshwater rivers to spawn.

Barbel: A tactile sense organ that is a threadlike growth from the jaw of some fish.

Broodstock: Adult fish retained for spawning.

Caudal: Referring to the tail.

Caudal Peduncle: The nerve bundle from the tail region of a fish.

Circuli: A ridge on a scale which can take many forms; often used in aging fish.

Cteni: Small sharp spines on the comb-like edge of a ctenoid scale.

Dorsal: Referring to backside.

Fertilization: The union of sperm and egg.

Food Chain: The transfer of energy from one organisms to another in the form of food.

Fry: The stage in a fish's life from the time it hatches until it reaches 1 inch in length.

Ganoid: Diamond-shaped scales that are connected to one another by joints.

Grade: To sort fish by size.

Groundfish: A marine bottom fish of commercial importance.

Hatchery: Location where fish are raised from fertilized egg to juvenile.

Incubation: Process by which eggs are placed in a favorable environment form hatching.

Native: Species which have historically lived and reproduced in a particular area.

Operculum: Gill cover.

Parr: A life history stage which marks the first year of a salmonids life cycle.

Placoid: Primitive, tooth-like scales found on sharks, so small that they give the shark a sandpaper texture.

Salmonid: Taxonomic fish group which contains salmon and trout.

Smolt: A life history stage which marks a juvenile salmonid's physiological transformation to life in a marine environment.

Spawn: The mating of male and female organisms to produce offspring.

Superchill: The low temperature at which a particular species of fish dies.

Yolk Sac: Source of nutrition for fish immediately after hatching.

ADDITIONAL RESOURCES

- Atlantic Salmon Federation. *Fish Friends: A Curriculum Supplement for Grades 4, 5 & 6*. St. Andrews, NB: Armour & Associates and Gaynor/Sarty, Huntsman Marine Science Centre, 1995.
- Franzen, Nathan and Mark Wiley. *Atlantic Salmon Teaching Guide*. St. Andrews, NB: Atlantic Salmon Federation, 1991.
- Iversen, Edwin S. and Kay K. Hale. *Aquaculture Sourcebook: A Guide to North American Species*. New York: Van Nostrand Reinhold, 1992.
- Maine Department of Marine Resources. *ABC Fish of the Gulf of Maine*. Augusta: DMR-Education Division, 1987.
- National Film Board of Canada. *The Atlantic Salmon* (film). Cat. no. 106C-0178-501.
- Northeast Fisheries Science Center. *Status of the Fishery Resources Off the Northeastern United States*. NOAA Tech. Memorandum NMFS-NE-108. Woods Hole, MA. Jan. 1995.
- Swift, Donald R. *Aquaculture Training Manual*. Cambridge, MA: Fishing News Books-Blackwell Science Publications, 1993.

Culturing Shellfish & Sea Vegetables

KEY CONCEPTS

Shellfish and sea vegetables are important aquaculture crops in the state of Maine. Shellfish that are being cultured for commercial sale are soft-shelled clams, mussels and oysters. A relatively new but extraordinarily successful aquaculture venture has been the culture of nori, a seaweed used predominantly in Asian cooking. In order to culture shellfish and sea vegetables, we must have a working knowledge of the species anatomy, ecology, life cycle, and culturing technique.

LESSON OVERVIEW

Students will explore the culturing of shellfish and sea vegetables in Maine. A dissection of the blue mussel will be conducted to examine the structural and functional attributes of a commonly cultured bivalve mollusk. Students may conduct additional experiments with oysters, clams, and mussels.

LEARNING OBJECTIVES

After completing this chapter, the student will be able to:

- Distinguish between shellfish and finfish.
- List the shellfish species which are cultured in Maine.
- Describe the process of culturing shellfish.
- Describe the process of culturing nori.
- Label the internal and external anatomy of a clam and/or mussel.
- Demonstrate dissection skills.

LEARNING RESULTS

MUSSEL DISSECTION

- A. **Classifying Life Forms:** Students will understand that there are similarities within the diversity of all living things.
2. Describe similarities and differences among organisms within each taxonomic level.
- J. **Inquiry and Problem Solving:** Students will apply inquiry and problem solving approaches in science and technology.
1. Make accurate observations using appropriate tools and units of measure.
- K. **Scientific Reasoning:** Students will learn to formulate and justify ideas and to make informed decisions.
3. Develop generalizations based on observations.

MATERIALS

Photocopies of the following student handouts: *Culturing Shellfish and Sea Vegetables in Maine*, *Mussel Dissection*, and *Mussel Diagrams*; blue mussels and other bivalves (live specimens and/or shells for comparison); saltwater solution; flexible knife; carmine powder; newspaper or table covering material; disposable latex/rubber gloves.

BACKGROUND

Shellfish, very simply, are all aquatic animals that contain some type of a shell. The three shellfish species which are cultured in Maine are the soft-shell clam (*Mya arenaria*), the blue mussel (*Mytilus edulis*) and the oyster (*Crassostrea virginica*). These three species all belong to the phylum *Mollusca* and to the class *Bivalvia*. The phylum *Mollusca* contains 100,000 different species divided into several classes which include bivalves, snails, chitons, squids and octopi. Most mollusks are marine, although there are a few terrestrial and freshwater mollusks. All mollusks have a foot and a visceral mass in common. The molluscan foot is used for crawling, swimming, and burrowing. The visceral mass is the main part of the body where all the important organs such as the heart, stomach, intestines, kidney, and gonads are found. All body systems—respiration, circulation, reproduction, digestion, and excretion—are located within the visceral mass.

The class *Bivalvia* is so named because organisms included in it are completely enclosed by a calcareous shell made of two halves (or *valves*). The two shells are held tightly together by a muscle called the *adductor* muscle. When this muscle is relaxed, the valves will stay open slightly; when it contracts, the shell closes around the animal. The shell offers protection and serves as the animal's external skeleton (*exoskeleton*). Shell-building material is produced by the *mantle* which lies between the body and the shell. The mantle secretes calcium carbonate and chemicals taken up from the surrounding seawater. The molluscan shell grows as the mollusk grows and stays with it for its whole life.

Most bivalves are filter feeders or suspension feeders, which means they strain tiny particles of food (usually phytoplankton) from the surrounding water.

STUDENT HANDOUT

Culturing Shellfish and Sea Vegetables in Maine

Molluscan Aquaculture in Maine

In the 1970s, companies in Blue Hill and on the Damariscotta River pioneered oyster aquaculture in Maine, using rafts to culture European oysters (*Ostrea edulis*). Hatchery-produced seed oysters were reared to market size in Japanese lantern nets, stacked trays, or floating trays suspended in the water. Suspension culture, in which oysters or mussels are grown off the bottom, in floating trays and on ropes, is a labor-intensive form of cultivation that requires continuous tending and cleaning of both gear and shellfish. On the U.S. East Coast, bottom culture is the preferred method of farming oysters and mussels now. Similar to conventional crop farming on land, bottom culture involves selecting areas of the sea floor that provide a natural food supply, necessary currents, minimum exposure to predators, and proper temperature and then "seeding" the bottom with shellfish stock that are left to grow to market size. Then they are harvested with a bottom drag from a boat. Both suspension culture and bottom culture depend on natural food supplies for growing the shellfish being raised.

Today, most east coast oyster farms grow American oysters (*Crassostrea virginica*). Hatchery-produced seed is reared until it is 25 to 37 millimeters (mm) long in floating tray nurseries that cover an acre or more of water. Before winter, oysters are set out on the ocean bottom at leased sites protected from heavy weather. With this system of oyster culture, the major problem is controlling predators, including crabs, oyster drills, and starfish. In two or three seasons, the industry can produce a high quality oyster for the restaurant half-shell market.

Blue mussels (*Mytilus edulis*) have been a staple food for Native Americans in what is now New England since prehistoric times. Along the Maine coast, wild mussel harvests have been recorded since 1887, with a peak of 2.6 million pounds of meat collected during World War II. Although mussels have always been considered a delicacy in Europe, it was not until the 1970s that the general public on this side of the Atlantic developed a gourmet taste for the bivalve. Marketing campaigns in Maine and the development of rope-culturing techniques produced demand and a high quality product. But the intensive labor required to harvest rope-grown mussels make this cultivation method uneconomical, except for mussels destined for the most discriminating restaurants.

Bottom culture of mussels, however, allowed a boom in mussel farming in the 1980s. Today, most mussel farmers select appropriate areas of the sea floor and seed the selected site with young mussels, spreading them out to optimize densities. The cultivated stock is left for one or two years to mature to market size and then harvested with a bottom drag.

In 1995, farm-raised mussels, which make up 10% to 20% of the state's total mussel landings, had a dockside value of more than \$1 million. Today, mussel producers are researching more efficient ways to collect juvenile mussels for seed, studying the importance of eelgrass in the life cycle of the mussel, and exploring better methods of harvesting and washing mussels.

Soft-shell clams (*Mya arenaria*) have always been an important cash crop for Maine. However, between 1984 and 1995, the number of clams harvested in the state dropped by 80%. No one really knows why. This dramatic decrease in wild clam populations has resulted in annual declines of nearly \$3.5 million to Maine clam diggers, even though the per-bushel price of clams continues to rise.

Beals Island Regional Shellfish Hatchery, a nonprofit, educational and research operation, has been instrumental in studying soft-shell clams and educating the public about this resource.

The hatchery produces millions of 1/4 to 1/2-inch soft-shell clams each year by spawning broodstock and raising the juvenile clams through to transplant size.

To induce spawning, broodstock clams are “shocked” by moving them from 50°F seawater to seawater warmed to 70°F. The change in temperature causes clams to release eggs and sperm into the water which mix together to produce fertilized eggs. Fertilized eggs (a 2-inch female clam may contain 1 million eggs) are collected and placed in large tanks in the hatchery where they are raised until they can be transferred to a nursery container (a surface tray or an “upweller”) through which nutrient-rich seawater passes. Once clams reach 1/2-inch size (usually the following spring), they are planted in mud flats overseen by municipal shellfish committees.

Hatchery personnel teach the general public, town shellfish committees, and clambers about the life cycle of clams and clam flat management. Seeding a depopulated clam flat involves transplanting young clams to traditionally productive areas that now have low clam populations due to overharvesting by humans; natural predation by birds, fish, crabs, moon snails, sandworms, bloodworms; or poor recruitment. The seeded area is covered with nets to keep out predators, and the transplanted clams are left to grow until they reach market size. Clammers benefit from this management strategy.

Developmental Shellfish Species

For Maine shellfish growers, the sea scallop (*Placopecten magellanicus*) offers commercial possibilities. Some of the technology employed in mussel culture may be transferable to scallop culture. Scallop spat are collected in the wild between August and October and are grown out to market size in suspension culture in pearl nets or lantern nets. After three or four years, sea scallops of marketable size fetch premium prices. Small scallops can be harvested a year and a half after spat collection. Canadian scientists are doing much of the research on sea scallops and are also investigating hatchery techniques.

At the Darling Marine Center, the marine laboratory of the University of Maine, researchers are studying the reproductive biology of species such as the Arctic surf clam and are developing techniques for spawning and raising mahogany quahogs (*Arctica icelandica*), surf clams (*Spisula solidissima*), and Stimpson surf clams (*Mactromeris polynema*). To date, growth trials for the Atlantic surf clam have been conducted at six sites in Maine; at least one aquafarm is marketing the product.

Sea Vegetables

A cool climate, an abundance of nutrient-rich waters, and a large tidal flow make the Maine coast ideal for the state’s newest aquaculture industry—seaweed farming. Nori, a type of red algae, is an essential ingredient of sushi, the Japanese delicacy composed of fish, vegetables, and rice wrapped in thin strips of the dried seaweed. In the clean waters of Cobscook and Penobscot bays, Maine seaweed farmers tend large floating nets seeded with spore from the filaments of nori, (*Porphyra yezoensis*).

Wild nori is native to Maine, but *Porphyra yezoensis*, a native to the Pacific, is easier to press and process into the paperlike sheets used in Japanese cuisine. In order to thrive, nori needs water with high nutrient levels and strong currents to bring the nutrients to the algae and to promote the exchange of oxygen and carbon dioxide. Maine nori farmers are using the cool summer waters of Cobscook and Penobscot bays to grow what is, in its natural habitat in Japan, a winter crop.

At the Coastal Plantations International, Inc. (CPI) plant in Eastport, large rectangular nets are seeded with nori spores, then climatized in a tank under lights that simulate September conditions in Japan. The nori attaches to the nets, and the nets are set out in clusters in bay waters where they are periodically raised in order to remove unwanted algae growth, as well as mussels and snails that attach themselves to the nets. The nori grows out to a length of about ten inches before it is harvested. Special "nori boats" are used to tend the nets and gather the seaweed. As a possible spin-off industry, the construction of the long, low, flat-bottomed craft may provide work for local boatbuilders.

Coastal Plantations not only cultivates *Porphyra yezoensis* in the waters around Eastport, but also operates the only nori-processing plant in the western hemisphere. A machine that looks like a printing press, equipped with paper-sized paddles, processes the seaweed and produces a high quality nori with a dark, lustrous color and a tender texture that dissolves in your mouth.

CPI intends to sell seeded nets of nori to local fishermen, who will raise the crop as a source of supplemental income and sell it back to Coastal Plantations for processing. A cooperative of nori growers from Blue Hill has purchased eight nets seeded with (*Porphyra yezoensis*) from CPI and is placing them at sites in Eggemoggin Reach and the Bagaduce River in Penobscot Bay to test the productivity of the area. The raw nori grown in the Blue Hill area will be transported to Eastport for processing into sushi sheets.

Besides a wrap for sushi, nori is also used in soups, salads, teas, and candy. Scientists are studying its therapeutic effects on ulcers and stomach cancer. Reputedly, nori prevents and cures scurvy, acts as an antibiotic, reduces blood cholesterol, and is high in B vitamins and minerals. Nori growers are selling spring growth to pharmaceutical companies that extract a dye from the seaweed, used as a tracer in biomedical research.

With the fastest growing market for nori in the world, the United States imports more than \$30 million worth of the seaweed each year from Asia. Maine nori farmers aim to capture 1% of the U.S. market and perhaps eventually enter the \$2 billion-per-year global market.

ACTIVITY: MUSSEL DISSECTION

(Adapted with permission from the Northern New England Marine Education Project at the University of Maine.)

Information

The dissection of shellfish requires care because mussels have few colored organs. However, there are many things that can be readily seen and the observations made during dissection can serve as the basis for discussion.

The dissection deals specifically with the Blue mussel, *Mytilus edulis*, but will apply equally well to many of the other bivalves (oysters, *Ostrea edulis* and *Crassostrea virginica*; soft-shell clams, *Mya arenaria*; hard-shell clams, *Mercenaria*; and bay scallops, *Aquipecten*). Specific mention of certain other bivalves is made throughout this dissection and if a specimen of one or more of these animals is included, the scope of the experience will be increased. It is, however, not necessary to have any other shellfish present to conduct a dissection of the blue mussel.

The mussel should be opened and dissected in salt water to reduce the damage to the gill and mantle structures. The initial cutting of the adductor mussels requires a sharp knife. Therefore, it is suggested that the teacher provide students with precut specimens or allow two to three animals for the student to “practice on” prior to starting the dissection. The problem with bivalve dissection is that one does not know what is inside the shell until it is opened and careless opening of an animal will destroy delicate structures.

Preparation

After you try the dissection yourself, duplicate and distribute the handouts *Mussel Dissection* and *Mussel Diagrams* to your class. Mussels (and other bivalves) can be purchased from a supermarket or fish market. They may be kept a week or so in the refrigerator without water or returned to the refrigerator after partial dissection to wait for the next class. There is no need to use any kind of preservative.

Procedure

1. Discuss the student handout *Culturing Shellfish and Sea Vegetables in Maine*.
2. Briefly go over the biology of molluscan bivalves.
3. Introduce the “Mussel Dissection” activity.
4. Distribute the student handouts *Mussel Dissection* and *Mussel Diagrams*.
5. Students may work in teams, groups, or as a class following a teacher demonstration.

MUSSEL DIAGRAMS

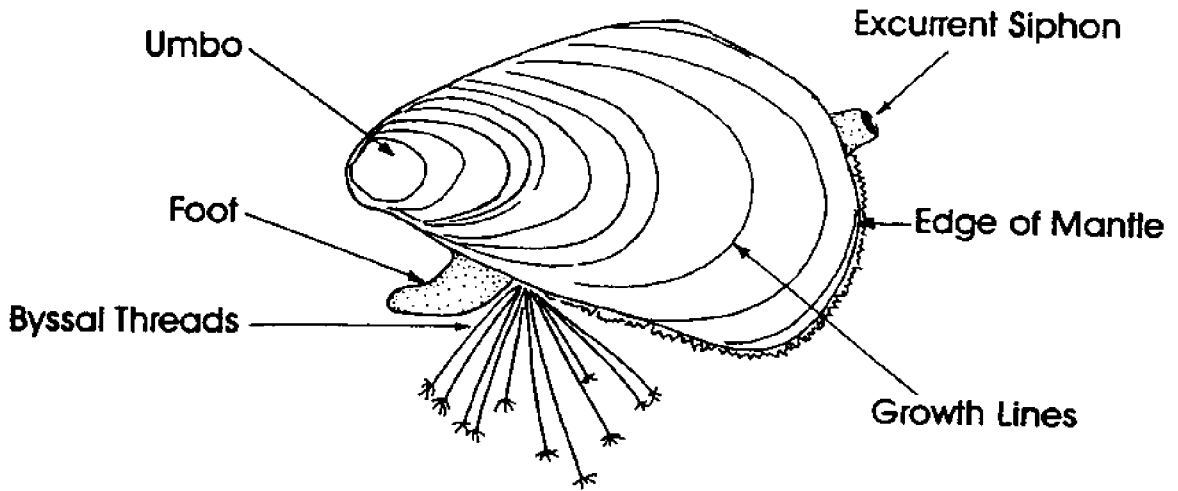

Figure 1. Mussel Exterior

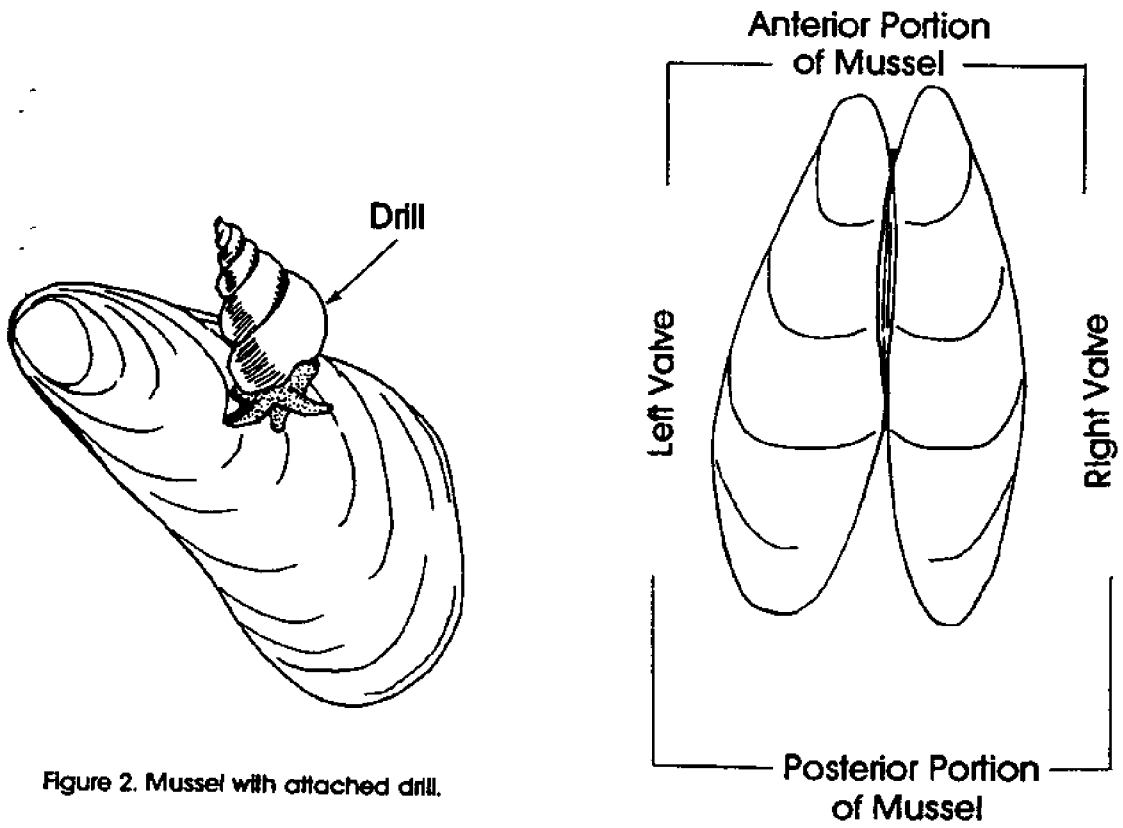

Figure 2. Mussel with attached drill.

Figure 3. Mussel showing left/right valve orientation.

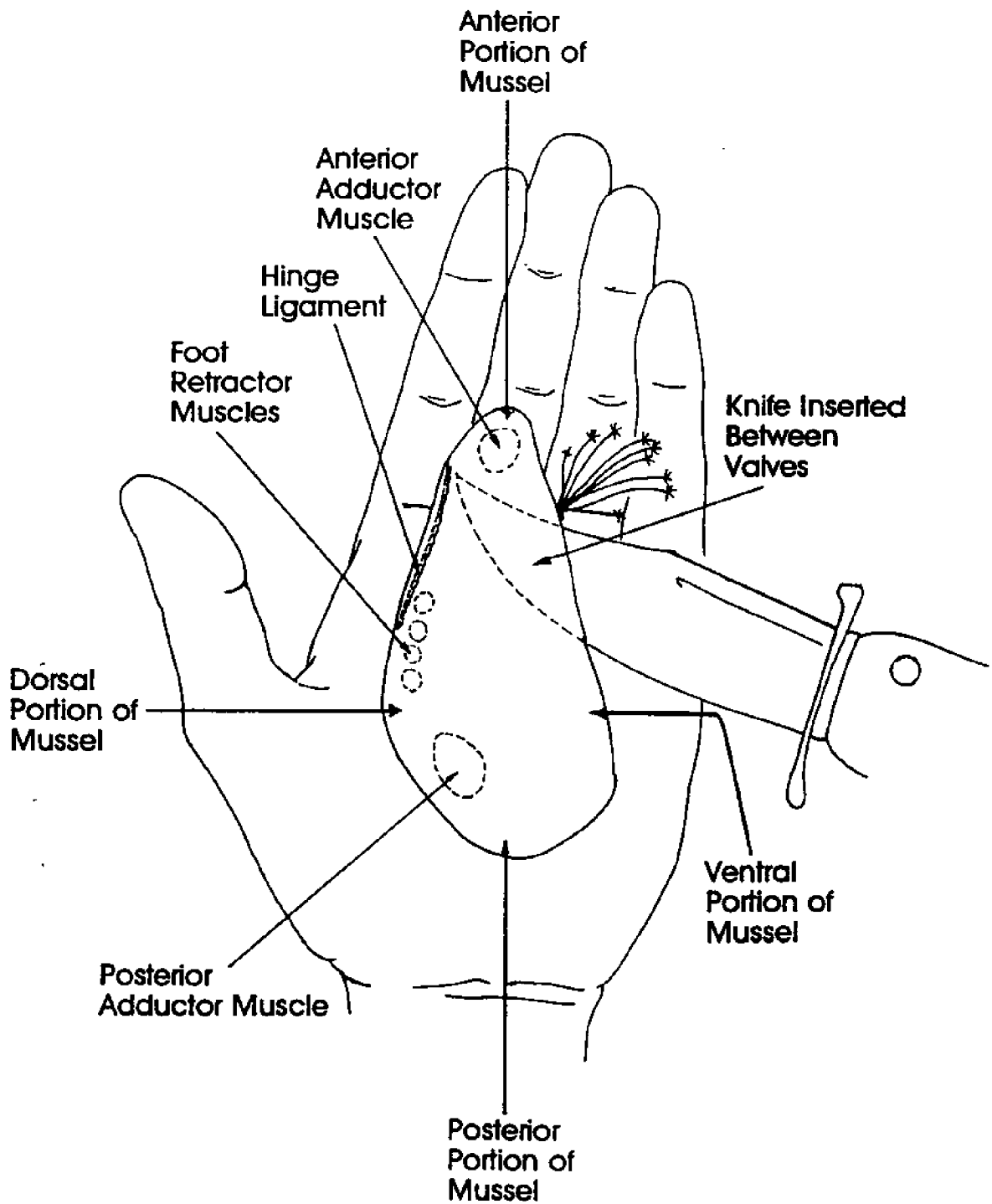

Figure 4. Mussel oriented in hand for beginning dissection.

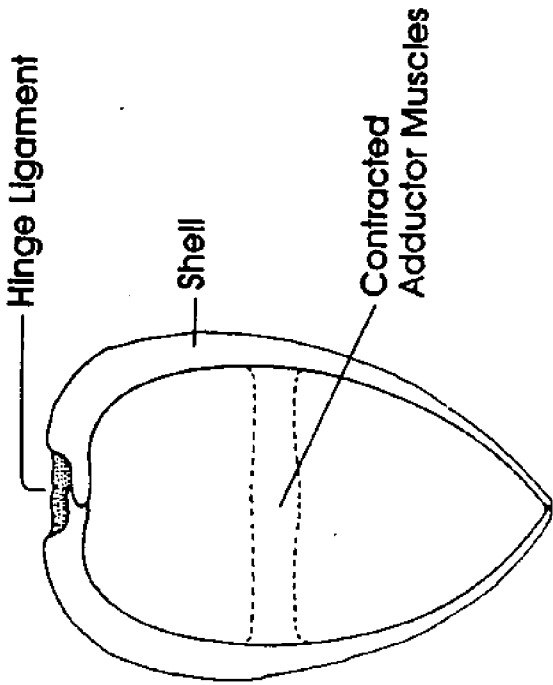

Figure 5. Closed valves.

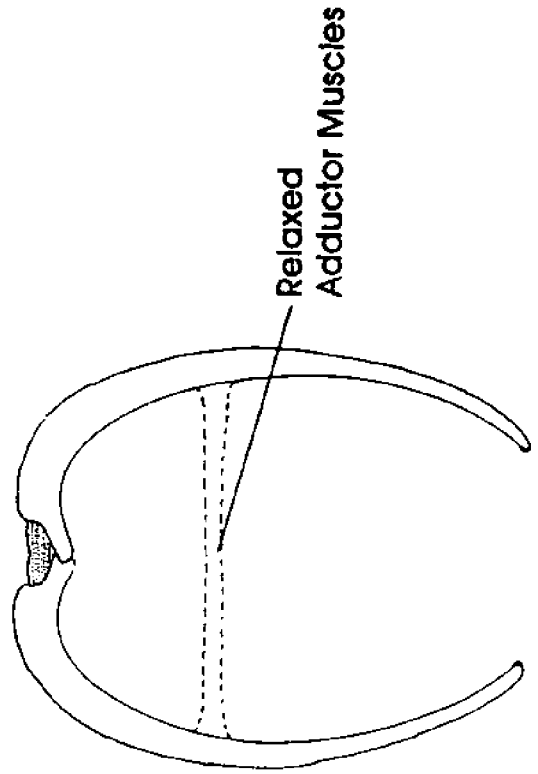

Figure 6. Open valves.

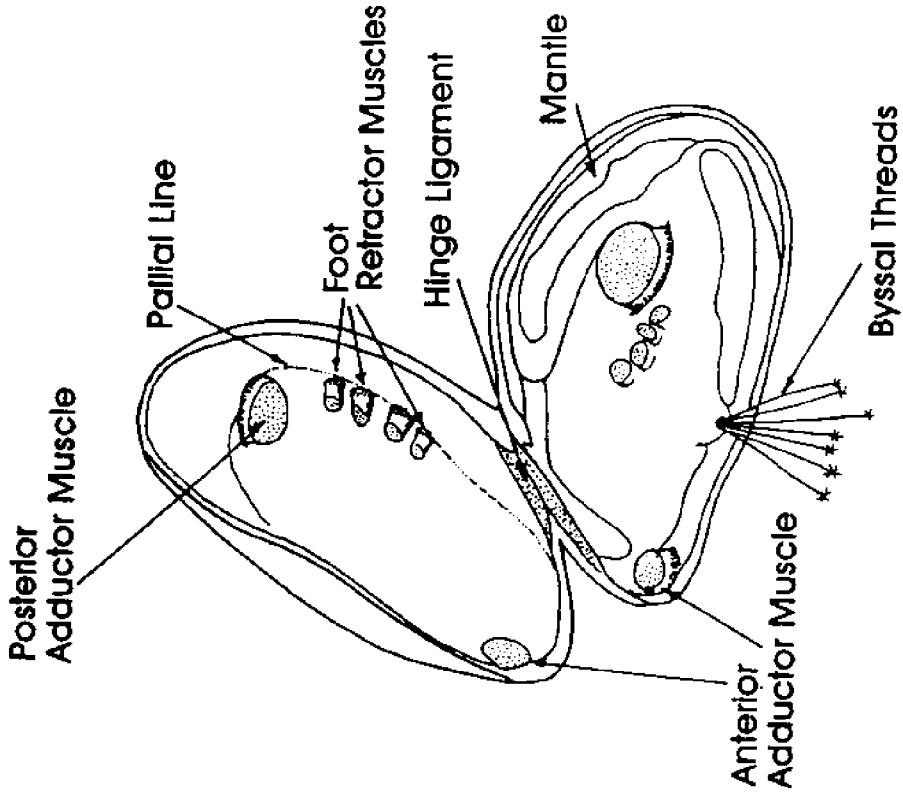

Figure 7. Mussel with left valve lifted.

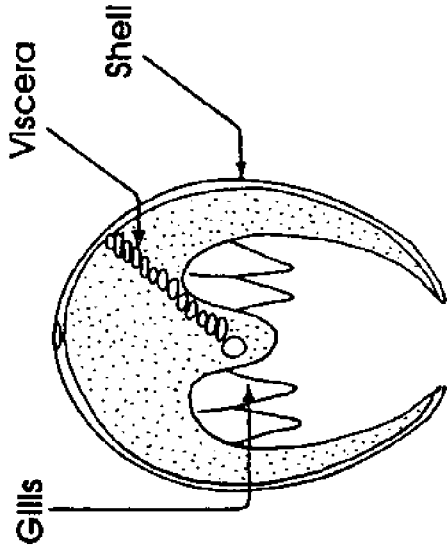

Figure 9. Cross-section of mussel showing gill location.

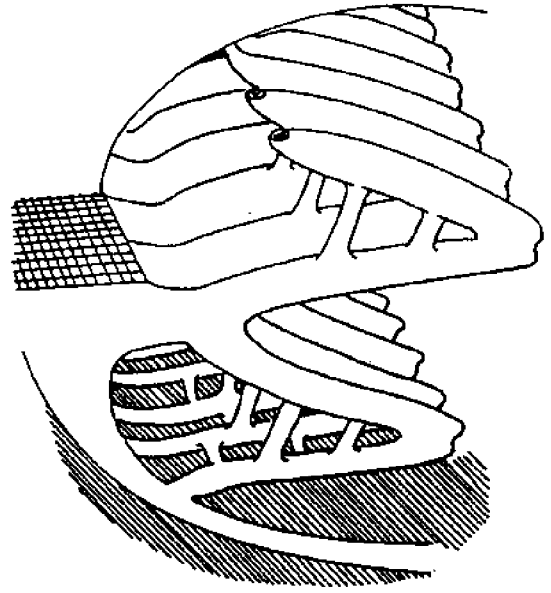

Figure 10. Gill detail.

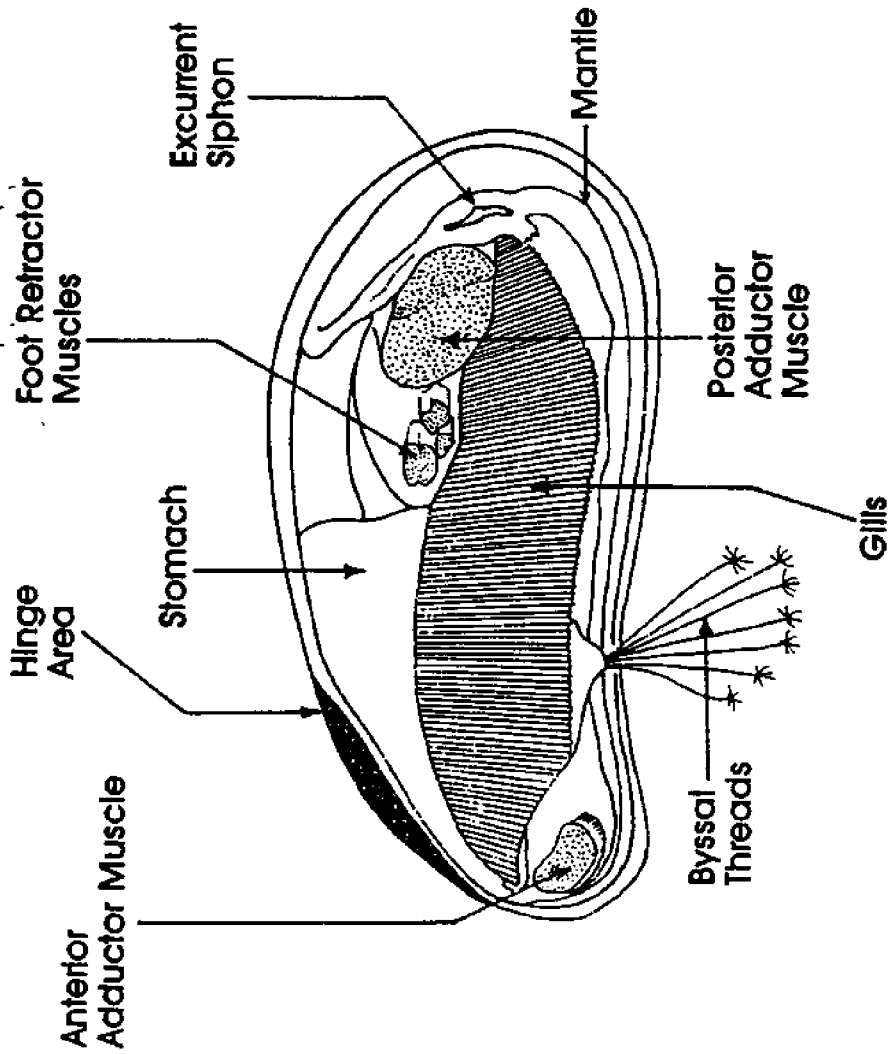

Figure 8. Mussel with left valve removed, exposing gills.

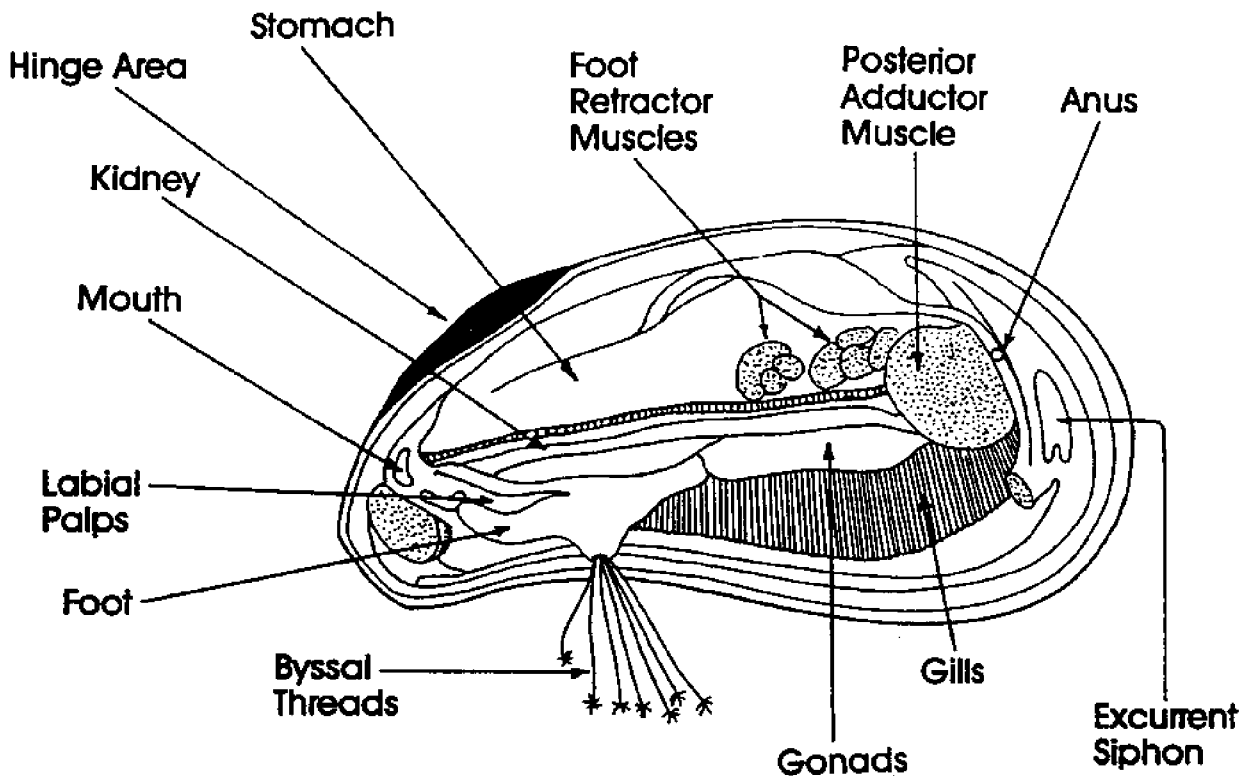

Figure 11. Mussel with left valve and gill removed to expose organs.

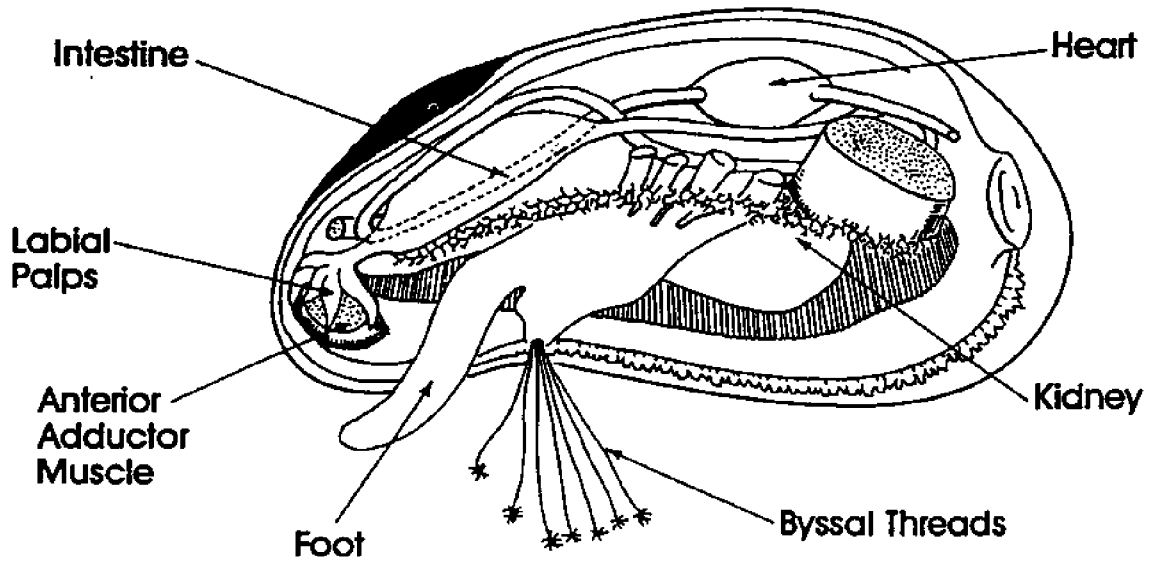

Figure 12. Anatomical drawing showing Intestinal tract.

STUDENT HANDOUT

Mussel Dissection

Instructions

Carefully read through the following procedures and make observations accordingly.

Procedure

External Anatomy

1. There are several things to observe about the outside of the mussel. The first is the presence of concentric growth rings on the shell. Just like the rings visible in a cross section of a tree, there is a direct relationship between the spacings between the rings and environmental conditions. Shell morphology (i.e., its form and structure) reflects growth pattern and is characteristic of each species, though pronounced irregularities can occur under disease conditions. ***How many growth rings are present on the shell of your specimen?***
2. The next thing to observe is the presence of the *byssal threads*. These threads are laid down within a few minutes and provide the mussel with the ability to hold on. Test the strength of the byssal threads by trying to pull one apart. ***Why do you think it is so important that the mussel has a means of anchoring itself to a substrate?***
3. The last external feature to note is the presence of a cartilaginous, rubbery material on the back of the shell. This acts like a hinge and allows the mussel to open the two-way valves by a pivoting action which will be discussed later. If the organism is healthy, none of the internal organs, mantle, gills, siphon, or foot should be protruding from the shell. ***Is your specimen healthy?***

Internal Anatomy

4. Orient the mussel in the hand as shown in Figure 4. Familiarize yourself with the four exterior areas (anterior, or head end; posterior, or rear end; dorsal, or top area; ventral, or bottom area) and sides (left and right valves, see Figure 3). If the mussels have been cooled at 2-3°C (35-38°F) for a half hour prior to dissection, adductor muscles will be relaxed and the process of opening shells will be simplified. Try to open the mussel with your bare hands without damaging the shell. *What function do you think the adductor muscle serves?*

5. Insert a flexible knife at the area shown in Figure 4, and gently slide it across the interior of the upper, left valve. Care should be taken to keep the knife blade from damaging the internal organs, which will be located in the central region of the mussel. Three major muscle groups will have to be severed before the shell can be easily lifted to expose the organs: (1) posterior adductor, (2) foot retractor muscles, and (3) anterior adductor muscle. The posterior is largest in size, and the most easily cut. The anterior adductor may be located and cut after the other two muscle groups have been cut, allowing the valves to open. If there is not a marked relaxation following your cutting motion, you may have to repeat it, always seeking to avoid damaging internal organs, particularly the delicate gills. (see Figure 5 and 6). *What function do you think the foot retractor muscle serves?*

6. The dissector will immediately be confronted by the unfortunate fact that almost everything inside a mussel is the same color. Also, many organs are similarly shaped and tend to overlay each other. Before examining the organs, you should examine the shell interior. When all muscles have been severed, lift the left valve up and locate the *pallial line* (see Figure 7), which marks the place where the mantle attaches. The inner layer of the shell is completely different in texture and color from the exterior portion of the shell. This is because the shell is not one material but is composed of layers of different materials. If it were possible to observe the cross-section of the shell under a microscope, three distinct layers would become apparent: the inner or *peristracum* layer, composed of *conchiolin* (mother of pearl), and two outer crystalline layers composed of calcium carbonate and conchiolin. *Where does the mussel obtain shell-building material such as calcium?*

7. The location and number of the adductor muscles is highly variable among bivalves and can be used as an identification aid when a dried shell is located on the beach. In most bivalves, there is also a distinctive pallial line that marks where the mantle attaches to the inside of the shell. It should be noted that, in certain bivalves, this pallial line is deformed into a pallial sinus by the presence of the *excurrent (exhalent)* siphon. A dried shell can be used as a rough identification aid to separate certain bivalves such as mussels from clams. The shape of the pallial sinus gives you an idea of the importance of the excurrent siphon to the animal. Burrowing animals depend upon this organ more than non-burrowing animals. *Examine a dried scallop, mussel, and clam shell. Can you locate the position of the adductor muscle(s) and the pallial line (sinus)? Sketch and label these parts for several different dried bivalve shells.*
8. With the left-hand shell removed, those structures depicted in Figure 8 should be visible. The structure which completely surrounds the body of the organism much like a blanket is the mantle. One of the functions of the mantle is the production of new shell material. In the mussel, the mantle is not fused along the ventral border. You may find that in cutting the adductor muscles to open the valves, you cut the mantle, with portions adhering to both valves. *Is the mantle of your specimen intact or divided in two?*
9. The internal organs of the bivalve can be divided into groups by their function: (1) respiring and/or eating, (2) locomotion, (3) reproduction, and (4) musculature. Each of these organ systems may be thought of as a separate entity for the purpose of this dissection, but it must be remembered that several organs may function together at any one time. *Using Figures 11 and 12, assign each labeled organ to one or more of the functional groups listed above.*

10. The gill is actually composed of two W-shaped *ctenidium*, fused along the dorsal surface (see Figures 8, 9, and 10). After examining the left gill in place (for location, refer to Figure 7), you may remove it by lifting and cutting carefully along its entire length. You will find that it is attached to the main mass of organs along a rather straight line from the mouth area to the posterior adductor muscle. Care should be exercised not to accidentally remove the kidneys while doing this (see Figures 11 and 12). When the gill is removed, the digestive organs should be easily exposed. ***What function(s) do the gills serve?***
11. The digestive system of bivalves consists of an esophagus, stomach, digestive diverticulum, midgut or intestine, and hindgut or rectum. Water is drawn over the gill ctenidia and the food particles are sorted out and covered with a mucous material. This food package is carried towards the *labial palps* and the mouth by tiny hair-like projections from the cell. These projections are called *cilia* and their beating creates a current directed towards the mouth. On reaching the palps, the food is sorted. The material which is small enough to be accepted passes onward and the larger material is passed outward towards the periphery of the mantle. ***Why is this food-sorting mechanism necessary?***
12. The small, mucus-bound food particles enter the mouth from the oral groove of the palps and move to the stomach via a short esophagus. Once the food reaches the stomach and intestine, it is subjected to mechanical abrasion by the crystal *style* and chemical degradation by the enzymes and chemicals in these organs. Food is sorted by ciliary action and conveyed to the digestive diverticulum and eventually is excreted at the anus into the cavity of the shell. Here the feces (the matter which has passed through the digestive tract) and the pseudo-feces (the material which was rejected at the labial palps) are both discarded through the excurrent siphon to the outside. ***Using Figures 11 and 12, trace the digestive path of a food particle.***

13. The foot is the organ of locomotion. In animals such as the soft-shell clam, the foot is used to burrow. Burrowing is accomplished by extending the foot through the mud and then causing the end portion of this organ to swell, acting as an anchor. When the foot is secured, the retractor muscles which normally retract the foot are contracted, and since the foot is secured, the body moves toward the foot rather than vice versa. As the organism developed from a burrowing to a sedentary mode of life, it developed a byssal structure to secure itself to hard substrates. Since the mussel is a creature which clings to its substrate, you would expect to observe this byssal apparatus. Externally, the threads are easily apparent; internally, they can be seen to originate from the foot structure proper. *What function do you think the foot serves in the blue mussel?*
14. When the organism became more sedentary, the size of the foot decreased and the size of the byssal threads increased. The byssal apparatus functions in two ways to secure the animal to its environment. In the case of the mussel, threads are produced which act to secure the animal. In the case of the oyster, a gland produces a cementing agent which secures the animal directly to its substrate. The mussel foot is attached to the shell by a series of retractor muscles, and it is connected to the other organs by a blood and nervous system. It should be possible to locate the foot, which you will probably find "tucked" forward, almost under the mouth apparatus. *Locate the foot on your specimen. Measure the length of the foot and record below.*
15. The gonads usually lie in the foot below the visceral mass, and depending upon the species and time of year, their size can be highly variable. Many of the bivalves are functionally hermaphroditic—forming sperm and eggs in different parts of the same gonad. Other bivalves can change their sex in response to the need to balance the number of males and females within the population. This sex change can occur either as a single event or several times during the lifetime of the animal. Fertilization occurs externally, although the animal may hold the fertilized eggs within the shell in response to adverse environmental conditions. *What are some possible adverse environmental conditions which might cause an animal to retain its eggs?*

MAKING CONNECTIONS: ADDITIONAL ACTIVITIES AND EXTENSIONS

- **Mussel Activity: Water and Nutrient Passage in Mussels**

Place a live mussel in a container of sea water and observe its movements. When the mussel begins to filter, add some carmine powder, obtainable from science supply houses. Observe the filter currents. Then determine where water enters and where it exits. After about twenty minutes dissect the mussel carefully and observe where the carmine powder has collected. For additional information and activities, see Appendix G.

- **Clam Activities: Additional Information and Activities (Appendix G)**
- **Oyster Activities: Additional Information and Activities (Appendix G)**
- **Scallop Activities: Additional Information and Activities (Appendix G)**

GLOSSARY

Calcareous: Describing something that contains calcium carbonate.

Climatized: To allow an organism time to get used to a new climate.

Gonads: Sex organs.

Juvenile: The immature form of a living thing, not sexually mature.

Nori: A red alga aquacultured in Maine.

Optimize: To make the most of something.

Phytoplankton: Microscopic algae which is often an important food source for marine animals.

Spat: The spawn or juvenile form of bivalves such as oysters, scallops, and clams.

Visceral: Describing internal organs located in the thorax and the abdomen.

ADDITIONAL RESOURCES

Booker, James and Dawn Grover. *Gulf of Maine Marine Coloring Book*. Augusta: Maine Department of Marine Resources, n.d.

Coulombe, Deborah. *The Seaside Naturalist*. New York: Simon and Schuster-A Fireside Book, 1984.

Iversen, Edwin S. and Kay K. Hale. *Aquaculture Sourcebook: A Guide to North American Species*. New York: Van Nostrand Reinhold, 1992.

Jones, Elaine P. *A Teacher's Guide to Marine Life of the Gulf of Maine*. Augusta: Department of Marine Resources, 1993.

Maine Sea Grant Communications. *The Cultured Clam: Raising Soft-Shell Clams Downeast* (video). Orono, ME, 1992.

Northeast Fisheries Science Center. *Status of the Fishery Resources Off the Northeastern United States*. NOAA Tech. Memorandum NMFS-NE-108. Woods Hole, MA. Jan. 1995.

Northern New England Marine Education Project. *Is Our Food Future in the Sea?* Orono: University of Maine, 1981.

Swift, Donald R. *Aquaculture Training Manual*. Cambridge, MA: Fishing News Books-Blackwell Science Publications, 1993.

Aquaculture in the Classroom

KEY CONCEPTS

The best way for students to learn about aquaculture is to engage in a class aquaculture project. Growing freshwater or marine algae, or culturing clams allows students to use many science skills such as measuring, observing, sampling, record keeping, analyzing, and graphing. Furthermore, students will learn the importance of resource management, controlling environmental impacts, and maintaining natural ecosystems.

LESSON OVERVIEW

Students will experiment with aquaculture in the classroom by setting up and maintaining freshwater and saltwater aquaria and culturing algae.

LEARNING OBJECTIVES

After completing this chapter, the student will be able to:

- Observe live plants and animals in a semi-natural environment.
- Describe how to set up and maintain freshwater and saltwater aquaria.
- List the life requirements of several aquatic plants and animals.
- Describe how to culture freshwater and marine algae and clams.
- Describe how to isolate a variable and test it.
- Demonstrate measurement skills using calipers.
- Demonstrate the use of a hemacytometer to determine algae density.

LEARNING RESULTS

GROWING FRESHWATER ALGAE

- B. Ecology:** Students will understand how living things depend on one another and on non-living aspects of the environment.
4. Analyze the impact of human and non-human activities on the type and pace of change in ecosystems.
- J. Inquiry and Problem Solving:** Students will apply inquiry and problem solving approaches in science and technology.
1. Make accurate observations using appropriate tools and units of measure.
- K. Scientific Reasoning:** Students will learn to formulate and justify ideas and to make informed decisions.
4. Recognize the need to revise studies to improve their validity through better sampling, controls, or data analysis techniques.

MARINE ALGAE AND LIGHT

- B. Ecology:** Students will understand how living things depend on one another and on non-living aspects of the environment.
3. Analyze the effect of reproductive and survival rates on population size.
 4. Analyze the impact of human and non-human activities on the type and pace of change in ecosystems.
- J. Inquiry and Problem Solving:**
1. Make accurate observations using appropriate tools and units of measure.
 2. Verify, evaluate, and use results in a purposeful way.

K. Scientific Reasoning:

4. Recognize the need to revise studies to improve their validity through better sampling, controls, or data analysis techniques.

GROWING CLAMS

B. Ecology: Students will understand how living things depend on one another and on non-living aspects of the environment.

4. Analyze the impact of human and non-human activities on the type and pace of change in ecosystems.

J. Inquiry and Problem Solving:

1. Make accurate observations using appropriate tools and units of measure.
2. Verify, evaluate, and use results in a purposeful way.

K. Scientific Reasoning:

4. Recognize the need to revise studies to improve their validity through better sampling controls or data analysis techniques.

M. Implications of Science and Technology: Students will understand the historic, social, economic, environmental, and ethical implications related to science and technology.

2. Demonstrate the importance of resource management, controlling environmental impacts, and maintaining natural ecosystems.
4. Analyze the impacts of various scientific and technological developments.

MATERIALS

Copies of student handouts *Growing Freshwater Algae* and *Culture Media for Freshwater Algae* and various individual setups for aquariums.

BACKGROUND

A FRESHWATER AQUARIUM

(The following setup was reprinted with permission from NSTA Publications, 1980, from Science and Children, Carol D. and Carolyn H. Hampton, National Science Teachers Association, 1840 Wilson Boulevard, Arlington VA 22201-3000.)

Having an aquarium in the classroom lets children make firsthand observations of plants and animals and environmental interrelationships. Feeding habits, predator-prey relationships, behavior patterns, life cycles, and the effect of changing environmental conditions on populations are some activities for study.

Selecting a Container

First, determine the function of your aquarium. Do you want to keep a few aquatic organisms for a short time for a demonstration, for individual students, or for team projects? If so, very large jars, plastic containers, or battery jars are satisfactory. For more organisms that will be observed over a longer period, you will need to build a well-designed habitat of 57 to 95-liter (L) capacity. The shape of the tank should provide a maximum of water-to-air surface area to insure an adequate supply of oxygen; i.e., don't use round fishbowls with small openings.

If the aquarium is only a holding tank for short periods, sand or plants are not necessary. Only a satisfactory water source and a compatible temperature range are needed. Most aquatic animals survive well in diffused light to darkness; avoid southern and western exposures.

Second, determine the need for mobility of the aquarium and choose accordingly. If aquaria will be moved, use only small molded glass tanks or vessels. *Never* move glass or plastic tanks with reinforced edges. Moving a tank filled with water—or allowing one to dry for a long time—distorts the frame, loosens the glass, and causes leaks.

Setting Up the Aquarium

Wash the tank thoroughly with detergent. If the tank has been used before, add a little household ammonia to the water to help dissolve grime. Rinse with clear water at least three times.

Thoroughly wash enough coarse sand or small gravel with clean water to cover the bottom of the tank to a 3 to 4 centimeter (cm) depth. Run warm water into a plastic bucket containing the sand. Allow the sand to settle and pour the water off until the water remains clear.

Add a 3-cm layer of clean sand or gravel to the aquarium. Add one or two clean clam shells to help neutralize the water's acidity and to provide a source of calcium for animals with shells. Add a strip of copper (approximately 2 X 5 cm). Copper ions released from the strip will retard the growth of single-celled and colonial forms of algae.

Add the remaining sand or gravel. Landscape the aquarium so the sand level is higher in the rear of the aquarium. This creates a trough in front for removal of dead organic matter (detritus) that will accumulate.

Add to the tank either well water, rainwater, or water from springs, ponds, or streams. If tap water is used, let it "age" in uncovered containers for at least three days before using so gaseous chlorine escapes. Place a saucer or square of plastic on the sand. Pour the water in *slowly* so the sand is not disturbed. When the water is 15 to 20 cm deep, add plants.

Green Plants

Green plants make an aquarium more attractive. They provide cover for shy or young fish, remove some of the nitrogenous products released by animals, and absorb carbon dioxide.

The role played by plants in oxygenating aquarium water has been exaggerated. If there is enough air/water surface area, the oxygen concentration in the water will eventually reach the saturation point. Since the aquarium plants also use oxygen, they may actually compete with animals for what is available.

Plant the longer plants near the rear and the shorter sprigs near the center of the aquarium. Leave enough space in front for examining and handling animals and for removing detritus. Allow 8 to 10 cm between any two plants.

Fill the aquarium with water to within 2 cm from the top. Add several rocks (smooth sandstone or granite) for a scenic effect and cover for shy animals. Add a glass cover to reduce evaporation and contamination by dust and unwanted microorganisms. Glue small pieces of cork to the rim at each corner to leave space for ventilation.

Animals

The aquarium can be stocked with animals after several days. Give the water time to clear, reach room temperature, and dissolve adequate oxygen. In selecting animals, remember: (1) predators should be isolated from prey species until you want to study feeding behaviors; (2) animals that normally live in still ponds or quiet streams will adapt better than those from running streams because of the oxygen supply; (3) avoid animals that stir up the bottom sand or uproot vegetation; and (4) using 4 L of water per 2.5 cm animal prevents overcrowded conditions.

Native freshwater animals can survive in a classroom aquarium. Animal selection may vary with the students' ages, the science curriculum, organisms collected during field trips, the time of the year, the area in which you live, or your own preferences. Mature or older specimens are generally less hardy than young animals. Fish that are 3 to 5 cm in length are best to use. Several small animals are preferred to one large animal. A suggested grouping for a 38-L unaerated, unfiltered aquarium includes:

- 15-20 rooted and/or submerged plants
- 2 x 2 cm of duckweed
- 10 small snails (or 5 large snails)
- 8, 2.5-cm fish (or 4, 5-cm fish)
- 4 tadpoles
- 1 newt or larval salamander
- 1 mussel

Put one snail in the aquarium for each 4 L of water. Scavenger snails help remove sedimentary wastes and algae. Too many snails add excrement that is unsightly and supports algae growth. Avoid species that eat rooted plants.

When adding fish or other animals to a tank, allow them to remain in a plastic bag containing the water in which they arrived until the water temperature in the bag is the same as the tank's. Tip the bag to empty organisms into the tank.

Maintenance

Keep an aquarium with plants in medium light. Strong light favors algae growth. A window with a northern or eastern exposure (or a fluorescent ceiling light) provides the best light. Optimum temperature range will vary with organisms, but room temperature is usually satisfactory.

A common problem with classroom aquaria is overfeeding. Overfeeding leads to buildup of organic wastes, cloudy water, lowered oxygen concentration, and in some cases death. It is better to underfeed than overfeed. Remove any food that remains 30 minutes after feeding.

Daily care and weekly cleaning can slow down the processes of algae growth and accumulated organic matter. Check daily for dead plants and animals, and the accumulation of excess food. Remove sick or dead animals and any dead foliage. Fish gulping at the surface, bubbles accumulating at the edge of the water, and dead animals are all signs of pollution or the lack of adequate oxygen.

Remove detritus that accumulates in the trough at the front of the aquarium with a siphon or a baster by hand. Remove filamentous algae each week.

Many aquarium aids on the market enhance the use of aquaria for specific objectives and organisms. Filters, aerators, heaters, thermostats, and artificial lights are options. Accessories increase the cost of keeping a classroom aquarium. We have had success in maintaining aquaria without them.

A SALTWATER AQUARIUM

(The following setup was reprinted with permission from NSTA Publications, 1979, from Science and Children, Carol D. and Carolyn H. Hampton, National Science Teachers Association, 1840 Wilson Boulevard, Arlington VA 22201-3000.)

Bring the sea to your classroom by setting up a saltwater aquarium. While a marine aquarium is not as easily maintained as a freshwater aquarium, it is not a difficult task. If students follow instructions carefully, they will develop new skills and experiences and will soon be observing marine organisms in their own miniature ecosystem. In a class where a marine aquarium is maintained, student interests progress from casual observation, to studying feeding and behavior patterns, to taking responsibility for maintaining the tank and organisms.

In the ocean, water composition is quite stable because of the vastness and ability of seawater to dissolve and dilute water substances. Water in any given area is constantly circulated by tides, currents, and wave action. The key to a successful aquarium is maintaining good water quality.

Selecting a Tank

Use an inert tank of all glass or Plexiglass construction. A recessed ridge on which a glass or Plexiglass lid can rest will allow splashed water and condensation to drip back into the tank. Tanks of 75 to 110 L capacity are recommended. Smaller tanks do not allow for a variety and a good balance of organisms. Two 75 L tanks can hold more animals and provide more ecological niches than one 150 L tank. If one tank becomes contaminated, a second one can function while the first is cleaned.

Filtration System

Marine organisms (especially fish and motile invertebrates) produce a lot of waste material consisting of ammonia, urea, and carbon dioxide (CO₂). Ammonia is of greatest concern because it is toxic in relatively low concentrations.

There are two basic types of filtration: biological and mechanical. The essential filter for a marine aquarium is the under-gravel filter, also called a biological filter because it relies on bacteria. As soon as the tank is set up, nitrifying bacteria and other microorganisms attach to the gravel and filter substrate surfaces. The microbes extract waste products and decaying matter from the water as it filters through the gravel. Ammonia and urea are converted to less toxic compounds called nitrites and finally to end products called nitrates. Nitrates, while still toxic, are only lethal at high concentrations. Green algae take up the nitrates and convert them into plant biomass. Nitrates also may be removed by a mechanical filter.

A mechanical filter is not an absolute necessity. In conjunction with a sub-gravel filter, it will improve the quality of the water by removing particulate matter and keeping the dissolved oxygen concentration high. Usually this type of filter is a box attached to the outside of the tank. The water moves down through a layer of polyester fiber, which filters out suspended particles, and then moves through a layer of activated charcoal which absorbs organic molecules. In time, this type of filter becomes a biological filter, as nitrifying bacteria attach to the fibers.

Both types of filters must be attached to an air pump to make them operate. For 75 L tanks or larger, two under-gravel filters are needed. If a mechanical filter is used, one is sufficient.

Water

Water for the aquarium may be either natural seawater or a medium made from synthetic sea salts. If you are located near the coast, marine organisms you collect will survive well in the water from their collection site. Seawater near the shore has a tendency to be polluted. Collect the water from a rock jetty or wade out into deeper water at high tide. Transport the water in plastic buckets. A good practice is to collect extra water to store for making water changes in maintaining

the aquarium. Store the buckets in a darkened place and tighten the lids to prevent algae and other unwanted contaminants from growing. The quality of the water improves with storage. Before using natural seawater, filter it through a funnel packed with polyester fiber.

You can make synthetic seawater by mixing prepackaged salts and minerals with distilled or aged tap water. Before using tap water, leave it in an open plastic bucket for three days to allow the chlorine to escape. For best results, use a well-known sea salts product from a reputable supplier. Beware of off-brand products at the pet stores.

Bottom Material

Good materials to use as a substrate are calcareous gravel limestone pebbles, coquina shells, or crushed coral. Slow dissolution of the calcium carbonate in shells and other limestone materials will help stabilize the pH of the water. Never use siliceous gravel, sand, or colored pebbles sold in pet stores. Be sure the particle size is greater than the holes in the sub-gravel filter.

Run fresh water over the bottom material in a plastic dishpan or bucket to clean it. Stir the material so dirt and organic debris float to the surface. As the heavy particles settle, pour off the floating material. Continue this procedure until the water remains clear when the gravel or shells sink to the bottom.

Setting up the Aquarium

Place the aquarium tank on a sturdy level surface. Select a location out of direct sunlight to prevent excessive algal growth. Never move a tank once it has any substrate and water in it or you will loosen the seams.

Install the sub-gravel filter, connecting air hoses and an air pump according to the manufacturer's directions. Cover the filter with 5 to 7 cm of substrate material.

Decorate the seascape with pieces of coral, dried sea shells, and sea fans. If you use rocks, be sure they have no holes, or have holes only large enough to permit recovery of animals that might hide in them and die. Soak seascape materials in seawater for 48 hours before placing them in the aquarium. Do not use metal objects or metal containing rocks because they may add toxic metallic ions to the water.

Place a shallow saucer on the substrate and fill the tank 2 to 3 cm from the top. Pour water onto the saucer to prevent gouging out the substrate material. With a wax crayon or piece of masking tape, mark the water level on the outside of the tank. Install the outside mechanical filter, if one is used. Turn on the air pump and adjust the valves. The bubbles should rise rapidly but separately through the tubes of the sub-gravel filters.

System Stabilization

Let the aquarium system operate for at least three days before adding any organisms. Add one hardy organism for a one-week period, then add others. This procedure will help build up nitrifying bacteria in the under-gravel filter and stabilize the physio-chemical environment. If it is not possible to condition the tank with a single organism, then let the aquarium stabilize for two weeks before adding a full population.

Stocking the Aquarium

In a classroom aquarium where temperature is difficult to regulate, the best specimens to maintain are those from the Middle Atlantic and the Gulf states (North Carolina to Texas). These specimens tolerate a temperature range of 18°C (64°F) to 21°C (70°F). Most biological supply houses advertise a composite of marine organisms for classroom aquaria.

If you live near the coast, collect your own specimens. Thoroughly clean and rinse two milk cartons. Cut off the tops and arrange the cartons in a large ice chest with seaweed in the bottom of each carton. Fill the cartons with seawater to just below the surface of the seaweed. Add one to three invertebrate specimens to each carton. Be careful not to submerge them in water. The most common reasons for specimens not surviving transportation are overcrowding and lack of oxygen. The wet seaweed will keep specimens' respiratory surfaces moist. If the animals are not completely covered with water, more oxygen will spread across their respiratory surfaces.

Place fish in a carton with just enough water to cover them. Collect specimens that are less than 5 cm in diameter. Do not pack predators with prey nor active organisms such as crabs with delicate animals. The biomass carrying capacity of a tank depends upon a number of factors, including the efficiency of the filtering system and the metabolic rates of individual organisms. A good rule of thumb is about 18 to 20 animals per 75 L tank.

Acclimatizing the Specimens

Float the bags or cartons holding the animals in the aquarium. Add a little water from the aquarium to the bags every 15 minutes. If the animals act nervous or contract, stop and wait before adding water more slowly. When the water temperature in the containers equals the aquarium's, remove the specimens with a dip net or with gloves and place them in the aquarium.

Feeding Rules

1. Cut off the power supply to the filters so small food particles will not filter out of the aquarium.
2. Do not give more food than can be eaten in one to two hours.
3. Keep a few scavenger animals to help clean up excess food.

Maintenance

Light

Do not expose the aquarium to direct sunlight. Excess light will cause undesirable algal growth and high temperatures. Diffuse light from a north or east-facing window is best. If the area is exceptionally dark, use an aquarium hood with fluorescent lights.

Temperature

Extreme body temperature changes lead to stress, burrowing, dormancy, disease, and perhaps death of the animals. Keep the aquarium at 21°C (70°F) to 24°C (75°F).

Salinity

The salinity (salt content) should be kept at 30 parts per million (ppm) or a hydrometer reading of 1.025. Once the aquarium is working and the water level is marked, add distilled or aged tap water to keep the water level stabilized. Never add more seawater; this increases the salinity. A glass cover over the aquarium will retard the rate of evaporation.

pH

The pH should be kept between 8.0 and 8.3. You can order a simple test kit from a biological supply house for this purpose. Calcareous shells and a natural growth of algae will help stabilize the pH. If the pH becomes too acid or falls below 8.0, remove a cup of aquarium water, add one teaspoon of bicarbonate of soda, mix well, and pour it slowly into the tank. If the water is still acid the next day, repeat the procedure until the water is the proper pH.

Water Changes

Make a partial water change once a month to dilute built-up wastes, replenish trace elements, and help maintain alkalinity. Siphon off one-fourth of the tank's volume and replace it with fresh seawater. Remove the mechanical filter once a month. Rinse the polyester fibers in fresh, aged tap water and replace the activated charcoal. Be sure to rinse the new charcoal to remove dust particles that could cloud the water.

Most detritus (partially decayed organic matter) will be drawn into the gravel where bacterial action will break it down. However, with time, some debris may accumulate on the substrate. Periodically stir and circulate this material so filter feeders use it. Remove large, accumulated materials with a kitchen baster. Each week, scrape algae from the inside aquarium walls with a plastic aquarium scraper. Encourage students to keep a log of their organisms and sources of food. This will be useful information in planning the composition of organisms for future aquaria.

ACTIVITY 1: GROWING FRESHWATER ALGAE

(The information, preparation, and student handout sections of the following activity were reprinted with permission from NSTA Publications, 1980, from "Growing Algae in the Classroom," *Science and Children*, Carol D. and Carolyn H. Hampton, National Science Teachers Association, 1840 Wilson Boulevard, Arlington VA, 22201-3000.)

Information

Teachers can use freshwater algae in middle and junior high school classroom experiments to demonstrate basic biological concepts, including requirements of living organisms. Teachers may not use living algae cultures because the cultures can be expensive. They may think culturing is impractical. While some algae are impractical for classroom use, many forms can be maintained with few technical requirements. In fact, most algal forms useful in classrooms can be cultured using short-term methods described here. You do not need pure culture techniques for keeping algae for class use. If you monitor temperature, light, pH, water quality, and have a satisfactory culture medium, algae are easy to grow in your classroom.

Preparation

Water

Water quality is of critical importance. Use filtered pond water, spring water, rainwater, or in some cases, distilled water. Never use chlorinated tap water. Heat all water for making solutions to 73°C (163°F) for at least 20 minutes and let it cool to room temperature before inoculating the water with organisms. Refer to specific formulas for media to see whether or not water should be made aseptic before or after mixing with other materials. You can make aseptic water by heating water in a covered container such as a stainless steel stockpot. Store the water in its covered pot and keep it in a place where it will not be disturbed.

Mark the water level on the side of the culture vessel and compensate for evaporation by adding distilled water, aseptic spring water, or rainwater. A glass poultry baster makes an excellent device for adding aseptic water to culture vessels. Keep the baster clean by storing it in a graduated cylinder with a beaker inverted over the bulb. Keep culture vessels covered with loose fitting lids or plugs to allow gas exchange and to keep out unwanted microorganisms and other forms of algae.

Glassware, Workspace, and Storage Preparation

Carefully wash all glassware used in culturing with warm water and detergent. Rinse twice in warm tap water. Residual detergent on glassware may kill algae so be sure the glassware is carefully rinsed. Store glassware upside down in a clean area. Sterilize pipettes or droppers used in transferring algae by boiling them in water for 10 minutes. Store the sterile pipettes or droppers, tips down, in a wide-mouth canning jar with a tightened lid. Do not sterilize rubber bulbs. You can keep these in a box until time for making transfers. Scrub working and storage surface with a 2% Lysol solution made of 2 milliliters (ml) Lysol and 98 ml water to help prevent contamination of cultures with unwanted algae and other microorganisms.

Procedure

1. Students should work in small groups to prepare a culture of algae using a starter culture and a medium which is appropriate for the specific algae species.
2. The culture should be placed in an environment with controlled light and temperature.
3. Have students record date, time, and baseline water quality measurements for the following parameters: pH , salinity, temperature.
4. Observe algae on a daily basis.
5. Students may experiment using a variety of mediums for a particular species of algae.

Discussion:

1. What changes did the students observe in the algae culture over time? What may have caused these changes?
2. How might the manipulation of light or temperature affect the growth of the algae?
3. What practical uses might there be for the culture of algae?
4. How are the needs of algae similar to those of other plants or other living organisms?
5. What is the role of algae in the food chain and the web of life?
6. What are some environmental factors that affect algae?

Aids for Identification

Hausman, Leon A. *Beginner's Guide to Freshwater Life*. New York: G.P. Putnam's Sons, 1950.
Klots, Elsie B. *The New Field Book of Freshwater Life*. New York: G.P. Putnam's Sons, 1966.
Reid, George K. *Pond Life*. Herbert S. Zim, Editor. (Golden Guide Series) Racine, WI: Western Publishing Co., Inc., 1967.

STUDENT HANDOUT

Basic Requirements of Living Algae

Temperature

Many species of algae will keep at room temperature. The optimal range of temperatures for classroom culturing is between 10°C (50°F) and 21°C (70°F). Avoid temperatures above 27°C (81°F) because higher temperatures are more damaging than lower ones.

Light

Keep cultures in a well-lit room near a window with a northern exposure. Never put algae in direct sunlight because the water may heat beyond the plant's tolerance. An ideal set-up is to install a 45-watt fluorescent tube 30 to 45 centimeters (cm) above the storage shelf. Between 200 to 400 foot-candles of light will result, adequate light for many species. You can put an inexpensive timer between the wall socket and the light plug and set it to furnish 16 hours of illumination and 8 hours of darkness.

pH

Keep the hydrogen ion concentration at neutral to slightly alkaline (pH of 7 to 7.5). Check your water source with pH test paper or have the water tested by a high school chemistry teacher who has access to a pH meter to make sure the pH is correct.

Transferring Cultures

Moving algae from one container to another is called transferring. For classroom short-term cultures, algae should be transferred every two to four weeks, depending on growth rate of individual species. Take care in transferring procedures to avoid contaminating the cultures with unwanted organisms. Single-celled and colonial forms are best transferred with a sterile pipette or dropper. Remove the pipettes or droppers from their storage chamber, making sure you do not contaminate the tips. Put the large end into a rubber bulb and draw water containing algae halfway up the glass tube. Do not draw water into the bulb. Hold the tip just under the surface of the new culture medium. Squeeze gently on the bulb to release the algae into the medium. You can pick up filamentous algae with forceps or tweezers. Sterilize the tips of the forceps by dipping them first into a container of alcohol (baby food jar, for instance) then passing them through the flame of an alcohol burner. The alcohol will ignite briefly. Allow the forceps to cool a few seconds, then dip the tips into the water containing algae. Pick up some strands of the algae and put them in the new culture. Another method of transferring is to use sterile cotton swabs from a drugstore, swirl the algal filaments around the cotton swab then transfer the filaments to the new medium and unswirl.

STUDENT HANDOUT

Culture Media for Freshwater Algae

The following media have proven successful with culturing certain species of algae under average classroom conditions.

Fertilizer Medium

Mix together 1 gram (g) of 4-10-4 or 5-10-5 (nitrogen, phosphorous, potash) fertilizer and 1 liter (L) of pond, spring, or rainwater. Heat the mixture to 30°C (86°F) for 20 minutes. Filter the mixture while still hot, before cooling it and inoculating the water with algae. Use for *Eudorina*, *Pandorina*, *Volvox*, and other volvocales.

Pringheim's Soil-Water Medium

This medium represents a miniature pond. The soil provides organic matter, growth factors, and trace elements. We have found that gas collecting bottles fitted with cotton plugs or heat resistant plastic foam plugs make satisfactory containers. Put a pinch of calcium carbonate (CaCO_3) in the bottom of the bottle. Layer over this 1.5 centimeter (cm) of rich loamy garden soil. Soil you have recycled from potted plants or greenhouses works well in this method. Fill the bottles to the shoulder with rain, spring, or distilled water. Plug with cotton or plastic foam stoppers. Put the bottles in a water bath and steam them at 70°C (158°F) for 15 minutes on two consecutive days to kill both vegetative and spore forms of algae and fungi that are in the soil. Let the bottles cool before inoculating. Use for blue-green algae: *Oscillatoria*, *Rivularia*; green algae: *Chlamydomonas* and *Closterium*; other desmids: *Eudorina*, *Pandorina*, *Volvox*, *Cladophora*, *Oedogonium*, *Spirogyra* (omit CaCO_3) and *Zygnema*.

Natural Water Medium

Fill a clean 3.8 L jar with water from the source where algae is found growing. Do not crowd the filamentous forms. Set the container in a north window. Use for *Rivularia*, *Chlorella*, and others for a few days.

Natural Pond Medium with Mud/Sand Substrate

This method also represents a miniature pond and is useful for some of the larger branching filamentous algae, particularly the stoneworts. Use a wide-mouth 3.8 L jar or a battery jar. Layer 1.5 cm of pond mud and/or sand. Cover with 1.5 cm layer of pre-washed aquarium gravel. Fill the container with filtered pond water without disturbing the bottom layers. Allow sediment to settle before planting the filaments in the substrate, using gravel to hold them in the bottom. Use for stoneworts: *Chara* and *Nitella*.

Aquarium Method

Keep a classroom aquarium or battery jar stocked with a few rooted plants and two or three small fish. You can introduce filamentous algae for short intervals of time. Clean away unwanted algae by hand. Use for blue-green algae: *Nostoc*, *Oscillatoria Rivularia*; green algae: *Hydrodictyon*, *Scendesmus*; desmids: *Cladophora*; and diatoms: *Spirogyra* and *Zygnema*, although neither form may live a long time.

ACTIVITY 2: MARINE ALGAE AND LIGHT

Information

Marine microalgae are extremely important organisms because they, like plankton, are among the first order producers in the food chain. They are also important as a source of oxygen. There are several single-celled green and brown algae that are used in laboratory aquaculture as a food source for oyster and clam larvae and juveniles. (*Tetraselmis striata*, a green dinoflagellate native to the tropics, is widely used in Maine aquaculture.)

As with freshwater algae, for successful culture, environmental factors must be controlled:

- 1) Sterile conditions are imperative. Keep glassware and all tools clean. Algae growing containers will range from 250ml flasks for the stock culture to large 22 liter carboys for mature cultures.
- 2) The algae are grown in filtered saltwater which may be obtained from the ocean or made using sea salt. Sterilize all water before using it. Never use chlorinated tap water. The pH range is 7.3 to 7.5.
- 3) Set up a grow area with controlled temperature and light. Temperature range is 20° to 25° C.
- 4) Algae are sensitive to parameters such as oxygen and carbon dioxide content. Oxygen levels must be supplemented by daily swirling of the culture container or by pumping in air or oxygen using an airstone and pump; although not essential, CO₂ may also be pumped in.
- 5) Maintaining the cultures requires weekly dilution of the algae (to avoid overpopulation) with sterile filtered seawater and the addition of nutrient supplements. (Miracle Grow works as a nutrient, using 2 tablespoons per gallon of water).

When raising algae as a food source for bivalves or small crustaceans, it is important to be able to determine the density of the culture. The organisms feeding on it require different amounts of algae at different stages of their development. For example larval shrimp require densities of 100,000 to 150,000 cells per milliliter (cells/ml) in the zoeal through myosis stages. A very rough estimate may be accomplished by observing the culture's color ; a more accurate count is done using a specialized tool called a hemacytometer. This is a slide with a grooved counting chamber. When the premeasured chamber is filled with an algae sample and viewed under a microscope, the organisms will appear as small green (*Tetraselmis*) or brown (*Isochrysis*) dots. To determine density (measured in cells/ml), the algae cells in several of the chamber's grid squares are counted, averaged, and then multiplied by 10,000.

Preparation

About two weeks prior to the experiment, the teacher should secure at least 10 ml of a marine algae stock culture for each class of students. Using sterile equipment and methods, this should be diluted with 90 ml of filtered seawater in a 250 ml flask, sealed with a cotton plug, set under grow lights and swirled daily. Keep at a temperature between 20° to 25° C. Add .25 ml (1 drop) of prepared nutrient solution every four days. (If using Miracle Grow, add 10 ml initially.)

Procedure

1. Using sterile techniques and working from a common source of healthy dense algae, each group of students should prepare an experimental culture flask by adding 10 ml of algae to a flask containing 90 ml of sterile seawater.

2. Determine a base density of each algae culture by gently removing a small sample with a sterile dropper and filling the counting chamber of a hemacytometer. Slowly place the coverslip at a 45° angle. Place the hemacytometer on a viewing platform of a compound microscope and focus under low power (4x). Move into high power and focus.
3. Count and record the number of microalgae in four different grids. To estimate the number of cells/ml, first calculate the average number of microalgae cells per grid by taking the total number of microalgae counted and dividing by four. Then multiply by 10,000 to obtain the number of cells/ml.
4. The flask containing the algae culture should then be sealed with a cotton plug and set under grown lights.
5. Observe daily. Also swirl daily or oxygenate using an air stone and air pump.
6. At the end of the week, again determine the density of each algae sample.
7. Then have each group determine an experimental location for their culture. One group's culture should remain under the lights as a control. The other groups should place their culture in an area with more or less light than the control. Students should predict whether the algae in the experimental jars will grow better than the control.
8. Have the students maintain their culture for another week. Observe daily.
9. At the end of the week, determine the density a third time.
10. Have students prepare a graph to show the microalgae cell count over time.

Discussion

1. Which culture of algae grew the best? Why do you think?
2. Were there any variables that were difficult to control?
3. Why is determining algae density important?
4. Is it possible to have too many algae cells? What happens in an overpopulation state?

ACTIVITY 3: GROWING CLAMS

Information

The soft-shelled clam, *Mya arenaria*, is a bivalve mollusk similar to the mussel, scallop, and oyster. It lives in soft-bottom intertidal and subtidal sediments ranging from Labrador to North Carolina. Clams are filter feeders, extending their siphons to the surface to obtain water for respiration and food, the microscopic algae and diatoms found in seawater. Clams propagate through external fertilization. The resulting larvae are without shells and spend a short time in the water column, swimming with the currents. As they develop, they grow shells and settle on the ocean floor. After the first year, they dig deeper into the sediment to establish a permanent burrow.

When they are legal-sized (two inches and larger), they are harvested for human consumption. Licensed clam diggers use a pronged "hoe" to harvest clams at low tide in the intertidal mudflats of protected bays. Historically, commercial clam digging has been an important industry in Maine; in 1993, 2.3 million pounds, at a value of \$9 million, were harvested. Since 1982, statewide clam landings have decreased dramatically. In eastern Maine, where the majority of the clams are harvested, landings have decreased 75%. Factors responsible for the decline include overharvesting, natural predation, and pollution and red tide (caused by the bloom of a marine alga, the dinoflagellate *Gonyaulax tamarensis*).

In the late 1980s, the Beals Island Regional Shellfish Hatchery in Beals, Maine was established as a public stock enhancement program for the purpose of replenishing publicly-owned clam flats. The hatchery's successful clam spawning and educational outreach program has benefited many coastal towns and students interested in marine ecology. The Hatchery obtains and spawns broodstock; rears larvae in tanks using marine algae for food; maintains nursery units in the ocean; and trains members of municipal shellfish committees how to use hatchery seed to reestablish productive mud flats.

Preparation

With care, immature clams can be raised within a classroom aquaculture set-up. It is necessary to set up a saltwater aquarium with both a filtration and aeration system. A chiller is not necessary as young clams will live and grow in water that is room temperature. However, keep the aquarium out of direct sunlight so the water does not overheat. Use sterile, filtered seawater or saltwater prepared using commercial sea salt. Perform water quality tests to check pH, temperature, salinity, ammonia, and nitrate levels. Also prepare floating trays with cloth-screened bottoms. The immature clams are small and the trays allow for easy observation. Because the clams' food source has to be well established, it is necessary to start growing marine algae about three weeks prior to the arrival of the immature clams. Be sure to add a silicate supplement (important for clam shell growth) to the algae as it is being cultured.

Procedure

1. When the clams arrive, allow about 24 hours for them to acclimate to the aquarium temperature and water before placing them on the screen trays.

2. Have the students select a small random sample (20 to 25) of clams to measure. Measure the length of each clam from tip to tip using calipers or the grids on engineering graph paper. Record the measurements and then return the clams to the tray.
3. Throughout the project, measure a sample of clams once a week.
4. Feed the clams daily. Use approximately 500 ml of dense algae culture per hundred clams. Simply pour the algae over the floating trays. The water should clear within 24 hours; if it remains cloudy with algae, skip a day of feeding.
5. When eating, healthy clams will open slightly and stick out their siphons; they orientate themselves upward on the screen instead of lying flat. A small muscular foot may be visible and occasionally the clams flip themselves.
6. Observe the clams daily looking for signs of disease. Unhealthy clams will stay flat on the screen and may develop a white film. Remove all unhealthy ones. One way to minimize the risk of a fungal infection is to "rinse" the clams with a freshwater spray once a week. Simply remove the whole tray from the aquarium and spray it gently.
7. As the clam grows, the mantle secretes new layers along the outside edge of the shell. The new shell will be white or nearly clear. Using a dissecting microscope, the students should be able to observe these new growth rings.
8. Other than removing clams for measurement or inspection, handle the clams as little as possible.
9. As with any closed system, it is important to continuously monitor the water quality, watching for an unusual odor or change in water color. Measure and record pH, salinity, temperature, ammonia, and nitrates weekly. If any of these parameters should go beyond a healthful range, be sure to remedy the situation immediately. If necessary, change the water.
10. When the young clams are 10 to 20 mm in length, release them at a local clam flat.
11. Have students make a graph showing average growth (in mm) over time.

Discussion

1. How does this model ecosystem compare to the Gulf of Maine ecosystem?
2. What problems if any did you encounter dealing with a closed system?
3. What factors influenced the growth of the clams? What might you do to enhance the clam growth?
4. What effect will releasing 100 clams have on the population of clams in Maine? What effect would releasing a billion have? What changes would have to be made to the classroom aquaculture system to accommodate a billion clams?

MAKING CONNECTIONS: ADDITIONAL ACTIVITIES AND EXTENSIONS

- **Adopt a salmon**

For a fee, the U.S. Fish and Wildlife Service offers a multidisciplinary watershed education program (grades 5 through 8) entitled "Adopt-A-Salmon" which consists of a curriculum package and an incubator stocked with fertilized salmon eggs.

- **Field trip to a coastal clam flat or an aquaculture facility**

- **Experiment using marine organisms**

If you have set up a saltwater aquarium with a chiller, students may conduct experiments to find out more about the natural habitat of marine organisms. 1) Determine whether periwinkles prefer a light or dark habitat. First prepare a tank so that one end is dark, the other light. Label two or more periwinkles with coded initials and place half the periwinkles in each end of the aquarium. Leave undisturbed for 24 hours. After 24 hours, observe and record the periwinkles' positions. Compile and analyze the data. 2) Determine what type of substrate lobsters prefer: sand or gravel. Prepare a tank with gravel on one end and sand on the other. Introduce one or more lobsters to the tank; be sure to leave undisturbed. On a daily basis, over a period of five days, observe and record the location of the lobster(s). Compile the data in a single table.

GLOSSARY

Acclimatizing: To become accustomed to a new environment.

Aseptic: Sterile, without the presence of microorganisms.

Broodstock: Adult clams retained for spawning.

Calcareous: Describing something that contains calcium carbonate.

Contamination: Being polluted or impure as a result of being in contact with another substance.

Detritus: Debris.

Dormancy: The inactive state of an organism.

Filamentous: Having long threads or filaments.

Inoculating: Putting an organism into a growing medium with the intention of culturing it.

Dinoflagellate: A marine single-celled alga with two flagella, or threadlike projections, used for movement.

Monitor: To watch or observe.

Optimal: The best, in reference to environmental conditions.

Toxic: Poisonous or harmful.

ADDITIONAL RESOURCES

Growing Algae in the Classroom

Growing Freshwater Algae in the Laboratory. Turtox Service Leaflet, No. 6. Chicago: Turtox/Cambosco, 1961.

Hampton, Carolyn H. and Carol D. Hampton. "Collecting and Observing Algae." *Science and Children* 17: 50-52; Sept. 1979.

James, Daniel E. *Culturing Algae.* Burlington, NC: Carolina Biological Supply Co., 1974.

Morholt, Evelyn, et al. *A Sourcebook for the Biological Sciences.* 2nd ed. New York:

Harcourt, Brace, and World, 1966.

A Freshwater Aquarium

A Sourcebook of Information and Ideas. London: William Collins Sons & Co., Ltd. (Nuffield Junior Science), 1967.

Aquatic Insects in the Laboratory. Turtox Service Leaflet 14 (New Series). Chicago: Macmillan Science, 1974.

Behringer, Marjorie P. *Techniques and Materials in Biology*. New York: McGraw-Hill, Inc., 1973.

DeFilippo, Shirley. "Aquarium Problems: How to Solve Them." *The Science Teacher* 42: 56-57; May 1975.

Hampton, Carolyn H. and Carol D. Hampton. "Elodea." *Science and Children* 16: 27-28; Nov./Dec. 1978.

Hampton, Carolyn H. and Carol D. Hampton. "Snails." *Science and Children* 16:42-43; Jan. 1979.

How to Feed Animals in Aquaria and Terraria. Turtox Service Leaflet 12 (New Series). Chicago: Macmillan Science, 1974.

Orlans, Barbara. *Animal Care: From Protozoa to Small Mammals*. Reading, MA: Addison Wesley, 1977.

Plants for the Fresh-Water Aquarium. Turtox Service Leaflet 11 (Original Series). Chicago: Macmillan Science, 1960.

Starting and Maintaining a Fresh-Water Aquarium. Turtox Service Leaflet 5 (Original Series). Chicago: Macmillan Science, 1960.

Swenson, William, Charles Barman, and Rudy Koch. "Aquaria on a Classroom Budget." *The Science Teacher* 43:35-36; Mar. 1976.

A Saltwater Aquarium

Bower, Carol E. *Keeping a Marine Aquarium: A Guide for Teachers*. Hartford, CT: The Children's Museum of Hartford, 1975.

Bradley, Michael. "All About Aquaculture." *The Science Teacher* 59(2): 36; Feb. 1992.

James, Daniel E. *Carolina Marine Aquaria*. Burlington, NC: Carolina Biological Supply Co., 1975.

Nicol, Ernest. "How-to-do-it: Hydroponics & Aquaculture in the High School Classroom." *The American Biology Teacher* 52(3); 1990.

Straughan, Robert P. *The Salt-Water Aquarium in the Home*. 4th ed. New York: Barnes and Company, 1976.

Waters, Barbara. *Small Oceans*. 4-H Marine Education Project. Amherst: University of Massachusetts, 1977.

APPENDIX A

Water Quality Variables

(Reprinted with permission from University of Maine Cooperative Extension and the
Maine/New Hampshire Sea Grant Program.)

Water quality variables which can be easily measured by volunteers participating in an estuarine citizen water quality monitoring project include: temperature, salinity, dissolved oxygen, pH, transparency, and fecal coliform bacteria. Samples to test for nutrients (ammonium, nitrate, nitrite, and phosphorus) and chlorophyll a can be collected and filtered by volunteers, but they should be analyzed by a professional laboratory.

TEMPERATURE

Water temperature exerts a major control over the distributions and activities of marine organisms. Temperature affects the rates of chemical and biochemical reactions. Many biological, physical, and chemical processes and activities are temperature-dependent. Among the most common of these are:

- ~ The solubility of compounds in sea water. Gases are more soluble in cool water than in warm water. As water temperature increases, the rates of photosynthesis and plant growth also increase. An increase in plant growth and photosynthesis means that more oxygen is produced, but it also means that more plant respiration and decay will use oxygen;
- ~ Distribution and abundance of organisms;
- ~ The metabolic rates of organisms increase with increasing water temperature. Increased metabolism increases the oxygen demand of many organisms. Extreme high or low water temperatures may exceed the tolerance limits for marine organisms. Juveniles of some species may become stressed and thus more vulnerable to toxic chemicals, diseases, and parasites; and
- ~ Density of water which affects inversions, mixing, and current movements.

Temperature and salinity are important variables to measure, because increase of either of them reduces the solubility of oxygen in water. Temperature can be measured in the field with an armored thermometer to the nearest 0.5 degrees C.

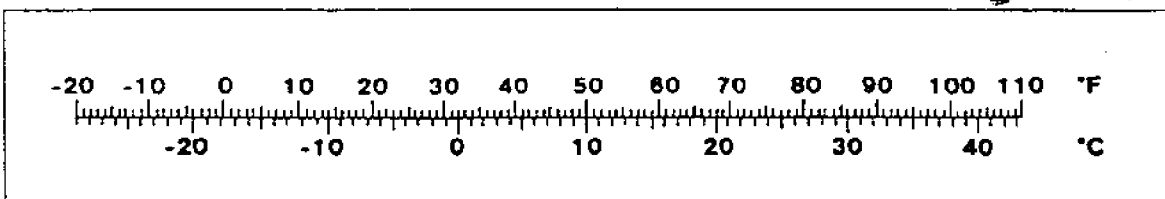
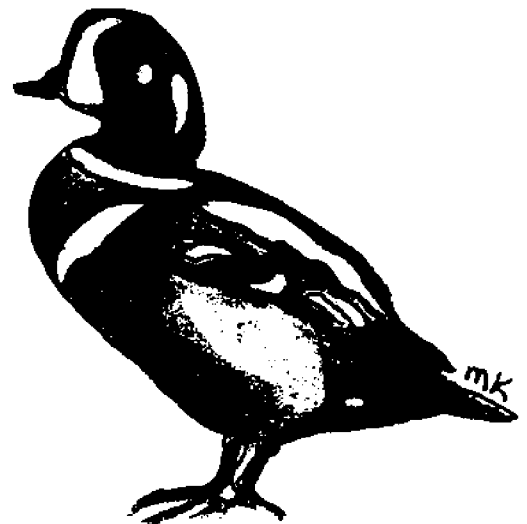

Temperature Conversion Chart from Fahrenheit to Centigrade

SALINITY

Salinity is the concentration of dissolved salts in the water, usually expressed in parts of salts per thousand parts of water (ppt). Fresh water contains few salts (drinking water usually has a salinity of less than 0.5 ppt), while sea water averages 35 ppt.

In estuaries, salinity changes with the tides and is also subject to fluctuations due to changes in the rate of dilution by fresh water from the land. Salinity is the principal factor controlling the distribution of marine organisms, especially as the salinity begins to decrease well below oceanic levels.

The determination and definition of salinity is something which has been given much attention over the years by marine chemists and physicists.

The salinity of marine waters is a fundamental property which can be used to determine much about the mixing and chemical history of the waters. In the open ocean and even in coastal waters, variations in salinity are small and thus it is necessary to use very precise methods to determine the extent of real differences. In estuaries, differences in salinity are typically much greater and the use of high precision methods is often counter-productive. The use of such methods can introduce unwanted background noise which may obscure the information sought.

Salinity can be measured by using a hydrometer, a salinity hand-held refractometer, or a conductivity meter.

Oceans supply 97% of the Earth's water. The next 2% is frozen, and the remaining 1% is found in rivers, streams, lakes, and groundwater.

DISSOLVED OXYGEN

Dissolved oxygen (DO) is essential for basic metabolic processes of most plants and animals inhabiting coastal waters. However, it is a particularly sensitive constituent because chemicals present in the water, biological processes, and temperature exert a major influence on its availability during the year.

A shortage of DO may not only be an indicator of pollution, but it can also be harmful to marine organisms. The ability of organisms to tolerate low dissolved oxygen conditions is extremely varied. However, if levels fall below 5 ppm (parts per million), certain species in the community may become stressed. Oxygen depletion is a significant event that can occur as a result of nutrient pollution and excessive phytoplankton production and can result in mass mortalities of fish and shellfish in coastal waters.

The oxygen in water comes from many sources. One of the largest sources is oxygen absorbed from the atmosphere. A second major source of oxygen is aquatic plants, including algae. During photosynthesis, plants remove carbon dioxide from the water and replace it with oxygen.

Once in the water, oxygen is used by marine organisms. Like land animals, fish and other marine animals need oxygen for respiration. Oxygen is also consumed by bacteria decomposing dead plants and animals.

The oxygen level of water is dependent not only on production and consumption. Many other factors work together to determine the oxygen level, including salinity, temperature, and atmospheric pressure.

Dissolved oxygen can be measured using a dissolved oxygen meter in the field or a Winkler titration method, which will give you dissolved oxygen in parts per million (ppm).

Oxygen is poorly soluble in water, roughly 100 ppm (parts per million) at 0-20°C compared to almost 1700 ppm for carbon dioxide at the same temperature.

CHLOROPHYLL *a*

Chlorophyll *a* is a green pigment contained in algae and other organisms and is necessary for photosynthesis. Its abundance is directly proportional to the abundance of algae in a body of water. Algal populations increase and decrease throughout the summer. As the population of algae increases, water clarity is reduced and a water body develops a greenish coloration, unless it is a brown or red bloom of **dinoflagellates**. As algal populations increase, chlorophyll *a* concentrations should increase. This increase leads to reduced water clarity.

Because chlorophyll *a* measurement requires special instrumentation, it probably will require the services of a well-equipped laboratory.

FECAL COLIFORM BACTERIA

The fecal coliform group of bacteria is used by the U.S. Food and Drug Administration (FDA) as a microbiological indicator of sewage pollution to determine the potential for public health risks through dispersal of **pathogenic organisms** and for ecological damage through **nutrient loading**.

Fecal coliforms were chosen as the indicator because they originate in the digestive tract of warm-blooded animals and are discharged into the environment with fecal wastes. Presence of fecal coliforms therefore indicate the presence of sewage which could contain pathogenic bacteria, viruses, **protozoans**, or parasites. Detection of the pathogens would be an inefficient and sometimes impossible undertaking because of their limited numbers and diversity. Fecal coliforms were also chosen because of their relative ease of detection and their viability in the aquatic environment.

One member of this group is sometimes considered as a representative of the fecal coliform group. In fresh water, the bacteria *E. coli* is used as an indicator of water quality by the Environmental Protection Agency (EPA), and the enterococci group is used as an indicator in marine swimming areas.

Fecal coliforms can be detected and counted in the lab by use of media with specific substrates and specific incubation times and temperatures.

Fecal Coliform Bacteria numbers that indicate problems:

Fecal Counts	Area Closed
14 colonies/100 ml of sample	shellfish growing area
200 colonies/100 ml of sample	swimming area

TRANSPARENCY

Transparency of water is a quick and easy measurement that integrates many important features of an aquatic system. Algae, microscopic animals, eroded soil, and resuspended bottom sediment contained in the water column interfere with light penetration and lessen the transparency of the water.

In late spring and early fall, there is usually less transparency because of plankton and algal blooms, and in the early spring the water may become more turbid with the silt being carried into the estuary with the spring run-off. Since sunlight is the basic energy source for most life forms, the degree of turbidity of the water has an important effect.

Transparency affects fish and other aquatic life by:

- ~ limiting photosynthetic processes and increasing respiration, oxygen use and the amount of carbon dioxide produced;
- ~ clogging of fish gills and feeding apparatus of bottom dwelling animals by suspended particles; and/or
- ~ obscuring vision of fish as they hunt food and smothering bottom-dwelling animals.

A Secchi disk can be used to determine how deep into the water column the light penetrates. This technique may be less useful on mudflats and is impossible to use in shallow water areas.

To build a Secchi Disk:

1. Use an aluminum sheet, plexiglas, or masonite that can be cut to a diameter of 20 centimeters, an eye bolt, washers, and braided dacron rope, (or some other rope that does not stretch), marked off every 10 centimeters for the first two meters and every 50 centimeters (half-meter) thereafter.
2. Divide the circle into quarters. Paint alternate quarters black and white.
3. Drill a hole through the center and assemble as shown in the diagram in the margin. (A metal weight will be needed if using plexiglas.)

MAKING A SECCHI DISK

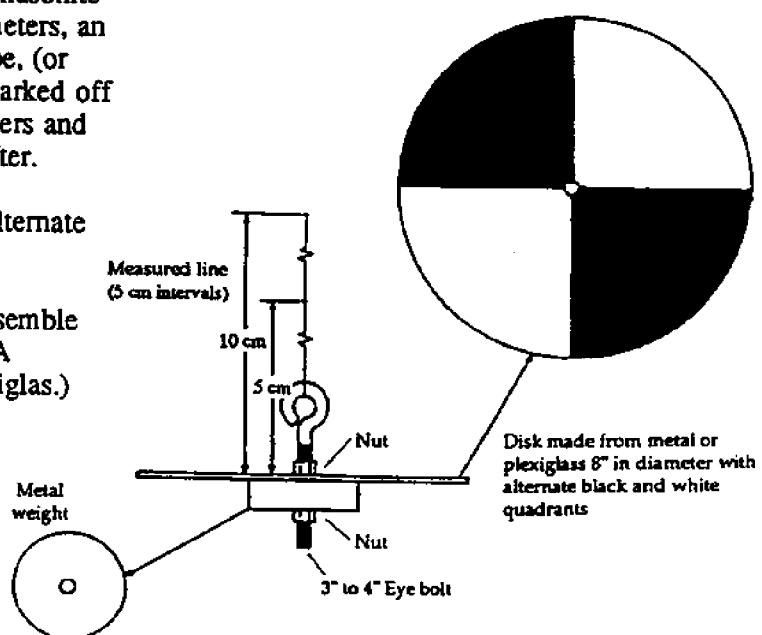

Prepared by Michigan Department of Natural Resources
Self-Help Water Quality Monitoring Program

pH

Most coastal groups monitoring in Maine do not regularly measure pH. It does become important, however, in certain situations such as during algal blooms or in freshwater streams flowing into an estuary.

pH is a measure of how acidic or basic (alkaline) a solution is. In any given solution some atoms of water dissociate to form hydrogen (H) and hydroxyl (OH) ions ($H_2O = H + OH$). The pH scale shows which ion has the greater concentration.

At a pH of 7.0 the concentration of both hydrogen ions and hydroxyl ions is equal and the water is said to be neutral. Pure water has a pH of 7.0. When the pH is less than 7.0, there are more hydrogen ions than hydroxyl ions and the water is said to be acidic. When the pH is greater than 7.0, there are more hydroxyl ions than hydrogen ions and the water is said to be basic or alkaline.

pH is defined as the negative logarithm of the hydrogen ion concentration which means that the concentration of hydrogen ions does not increase or decrease in a linear fashion; that is, a pH of 3 is not just twice as acid as a pH of 6. Increases are in powers of 10. At pH of 5, there are 10 times more H than at a pH of 6. A change in pH of one whole number is, therefore, a large change.

Water dissolves mineral substances it contacts, picks up aerosols and dust from the air, receives human wastes, and supports photosynthetic organisms, all of which affect pH. The buffering capacity of water, or its ability to resist pH change, is critical to aquatic life, as it determines the range of pH.

Generally, the ability of aquatic organisms to complete a life cycle greatly diminishes as pH exceeds 9.0 or falls below 5.0. Coastal marine systems are well buffered. Consequently, pH is not an important indicator. The exception is during intense algal blooms. In an estuarine system where the salinity is highly variable, pH is a useful indicator. Also, it becomes important where an industrial discharge could effect the pH.

In fresh water, most fish can tolerate pH values between 5 and 9, but the ideal range falls between 6.5 and 8.2. When water with a low pH value comes in contact with certain chemicals and metals, the acid may cause these substances to become more soluble or more toxic than normal. Fish that can stand a pH as low as 4.8 may die at a pH of 5.5 if low concentrations of iron, aluminum, lead, or mercury are present.

Ocean water is a highly buffered solution with a pH of 8.1 to 8.3. Fresh water is, therefore, more affected by acid rain than the ocean or estuaries.

pH can be measured with a meter. It is not possible to get an accurate measurement with a prepared kit, especially in salt water.

NUTRIENTS

1. Nitrogen

Nitrogen is one of the major constituents of plant and animal tissue. Its primary role is in the synthesis and maintenance of protein. Nitrogen enters the ecosystem in several chemical forms, including ammonia, nitrate, and nitrite. Nitrogen also occurs in other dissolved organic and particulate forms, such as living and dead organisms.

Some bacteria and blue-green algae can extract nitrogen gas from the atmosphere and transform it into organic nitrogen. This process, called **nitrogen fixation**, is an important pathway in the cycling of nitrogen between organic and inorganic components. Nitrogen is the **limiting nutrient** in Maine coastal waters.

2. Phosphorus

Phosphorus is another key nutrient and is found in the water as dissolved organic and inorganic phosphorus and also in particulate form. Phosphorus is essential to cellular growth and reproduction. Phytoplankton and bacteria assimilate and use phosphorus in their growth cycles.

When phosphate is highly concentrated in waters which contain oxygen, it combines with iron and suspended particles and eventually settles to the bottom, becoming unavailable to phytoplankton and temporarily excluded from the cycling process. Phosphate sometimes becomes a long-term constituent of the bottom sediments. When DO is absent, phosphorus is released and becomes available. Phosphorus is generally the limiting nutrient in freshwater lakes in Maine.

3. Uses of Nutrients

Just as fertilizer aids the growth of agricultural crops, nitrogen and phosphorus are vital to plant growth. These elements are supplied in significant quantities by sewage treatment plants, food processing industries, and urban and agricultural run-off. They are generally needed in a ratio of 16 parts nitrogen to one part phosphorus. If the availability of either drops below this ratio, it becomes the limiting nutrient in the growth of plant life.

Too many nutrients, on the other hand, can lead to over-abundances of phytoplankton, creating dense populations, or **blooms**, of plant cells. Blooms of green or blue-green phytoplankton can become a nuisance in the upper tidal freshwaters. As the blooms decay, oxygen is used up in decomposition. This leads to **anoxic** (and odorous) conditions causing fish kills and nutrient releases.

Nutrient samples can be collected and filtered by volunteers, but they require a qualified lab for analysis.

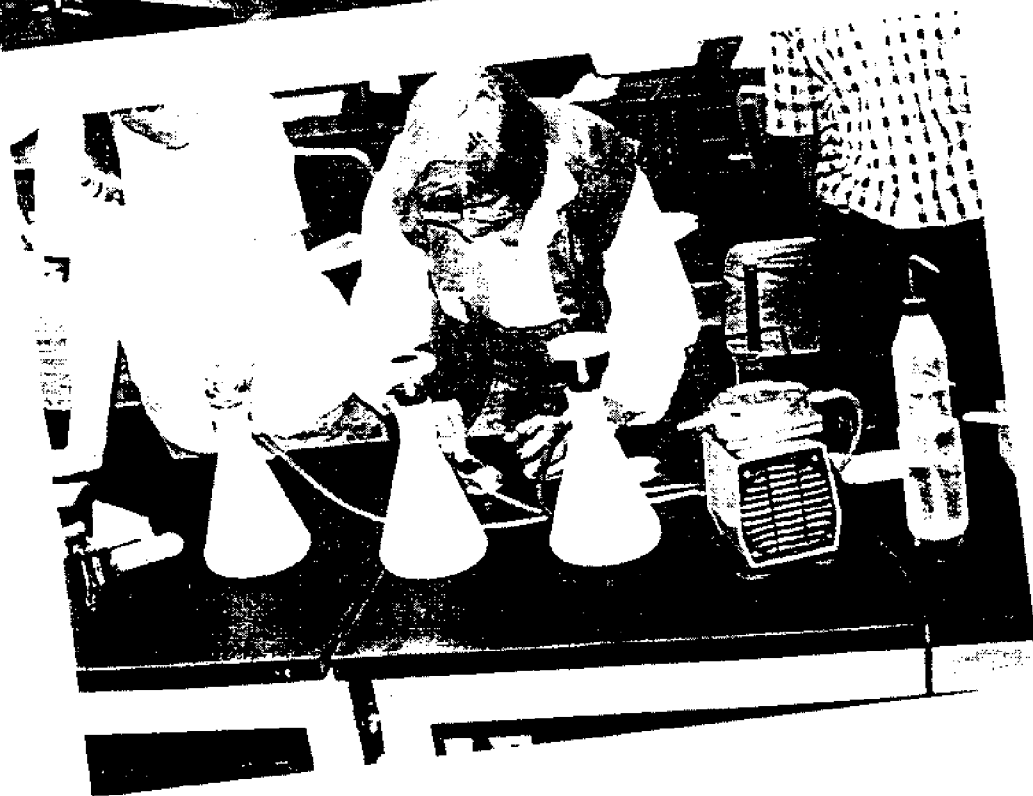
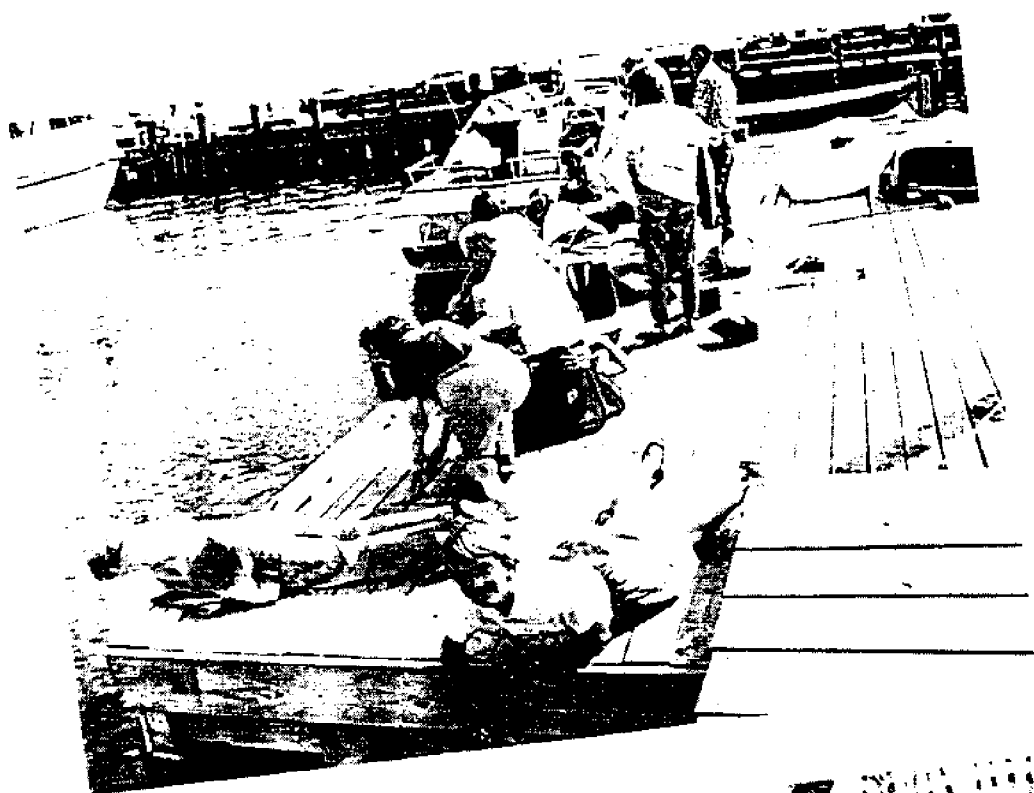

APPENDIX B

Identification of Seaweeds & Marine Organisms

(Reprinted with permission from Elaine P. Jones, Director of Marine Science Education,
Maine Department of Marine Resources, Bureau of Resource Management Education
Division, P.O.Box 8, W. Boothbay Harbor, Maine 04575; website:
<http://www.state.me.us/dmr>)

Irish Moss

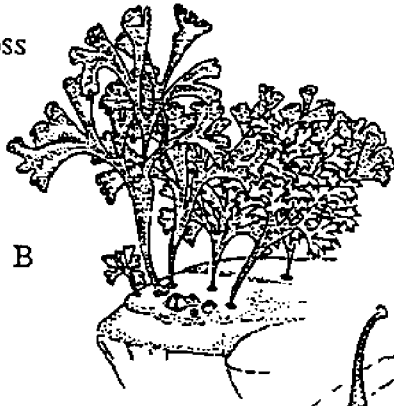

B

Fucus

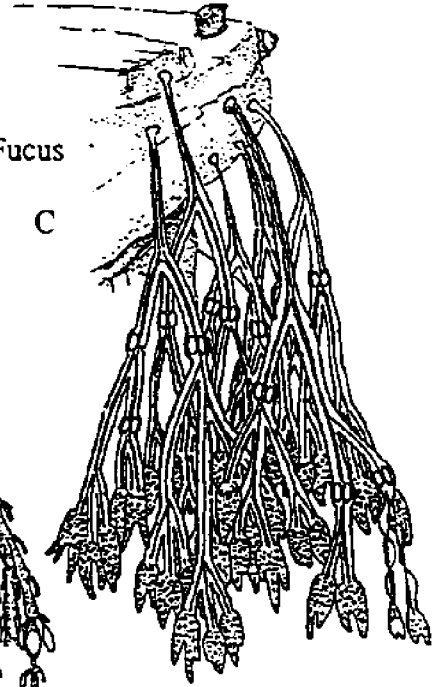

C

Laver

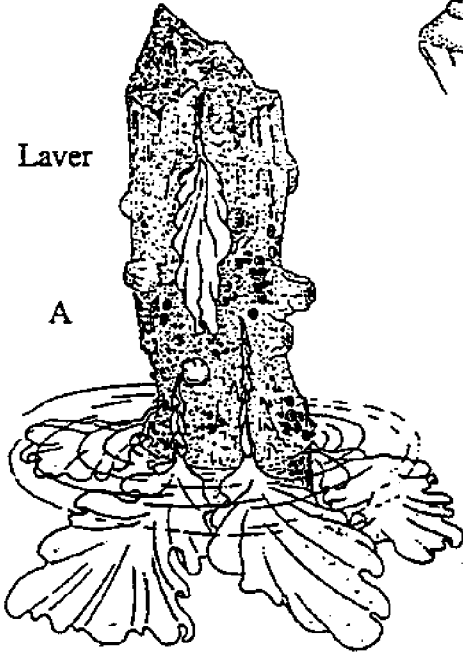

A



D

Ascophyllum



E

Colander Kelp



F

Winged Kelp

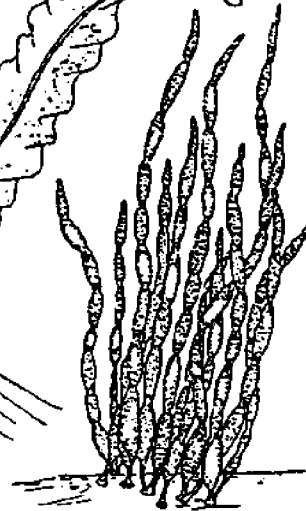

G

Tube Weed

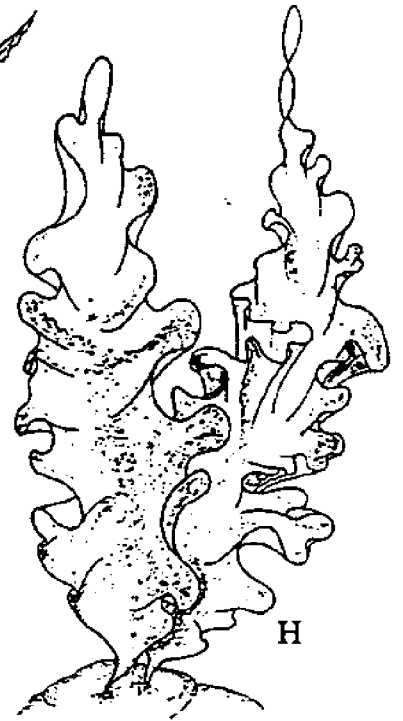

H

Sea Lettuce

Fringed Sea Anemone

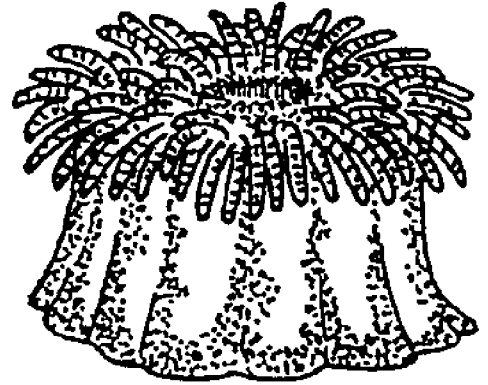
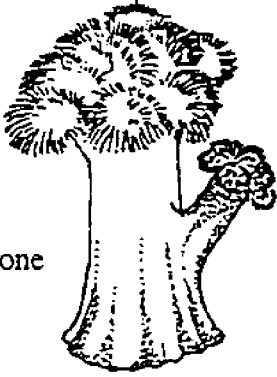

Moon Jelly

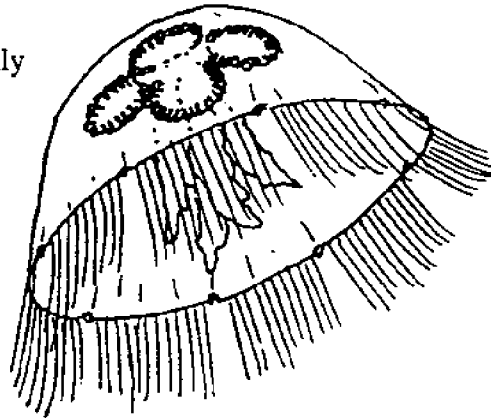

Northern Red Anemone

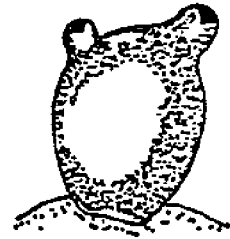

Blood Worm

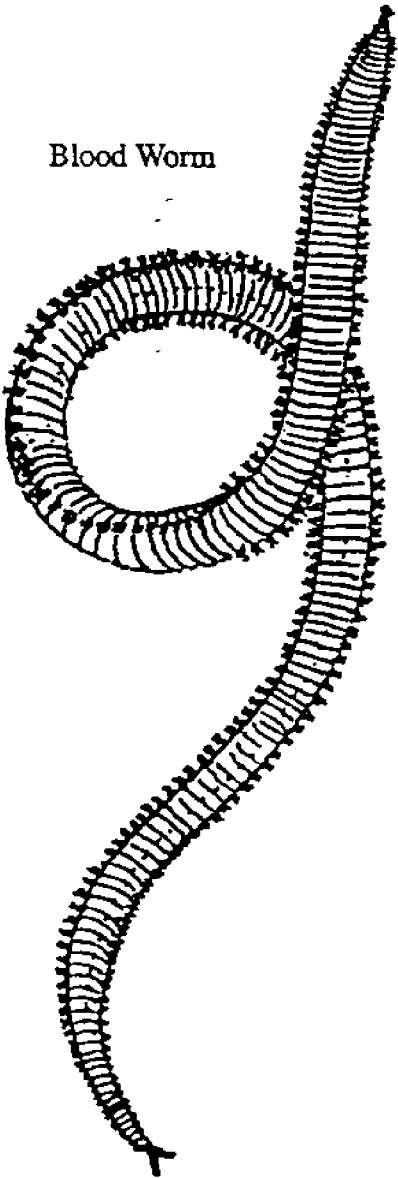

Sea Peach

Sea Vase

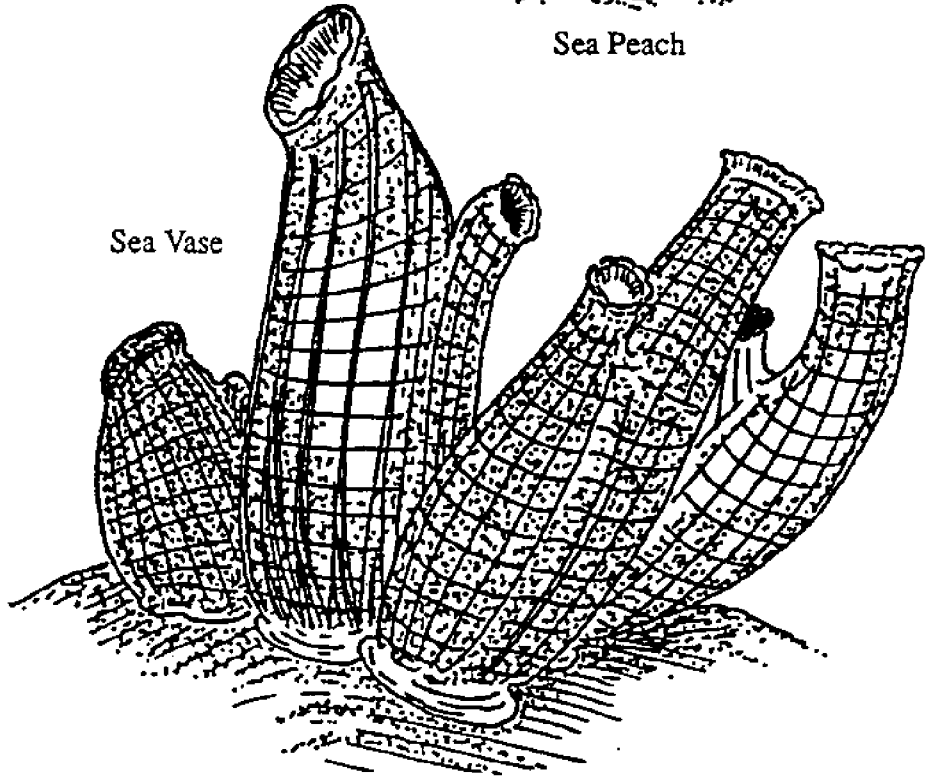

Northern Sea Star

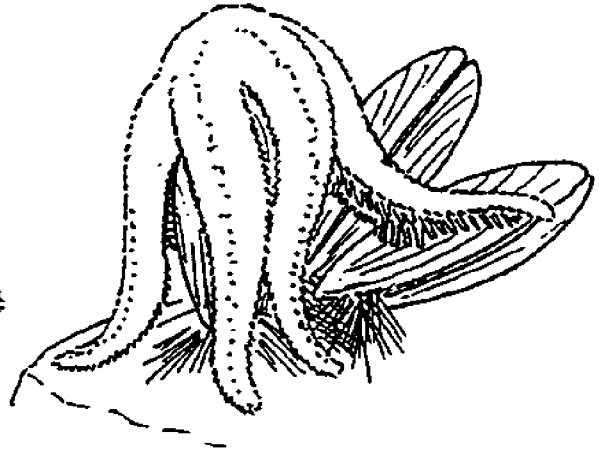
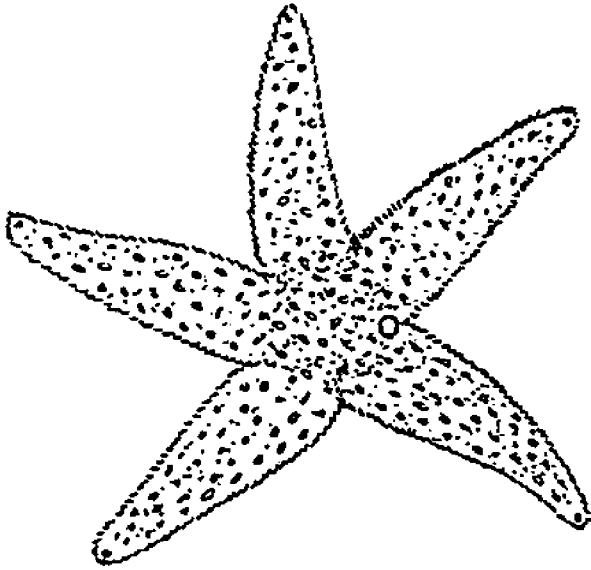

Blood Star

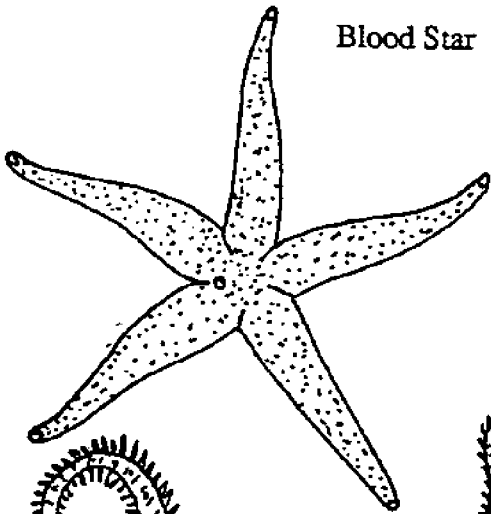

Mud Star

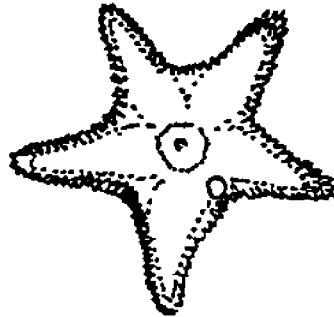

Daisy Brittle Star

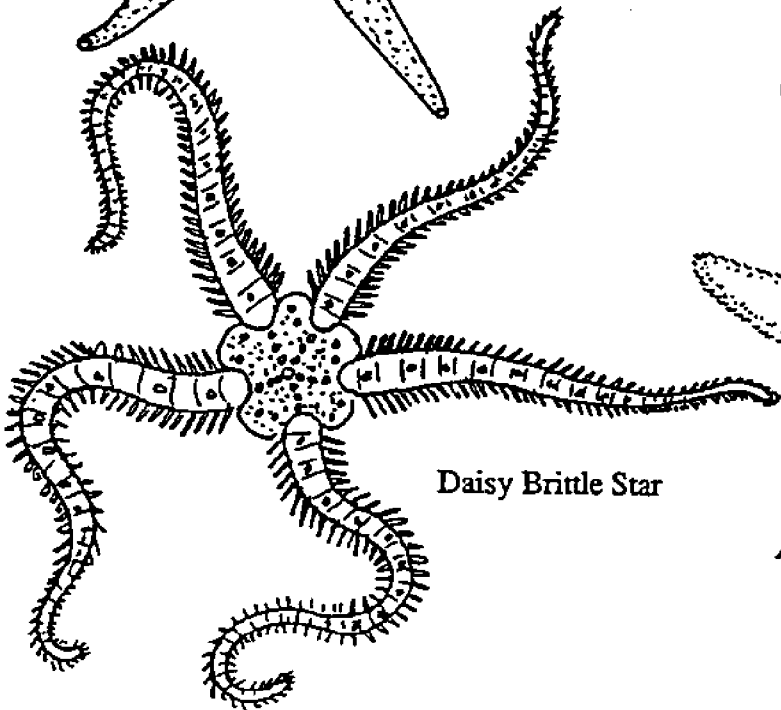

Purple Sunstar

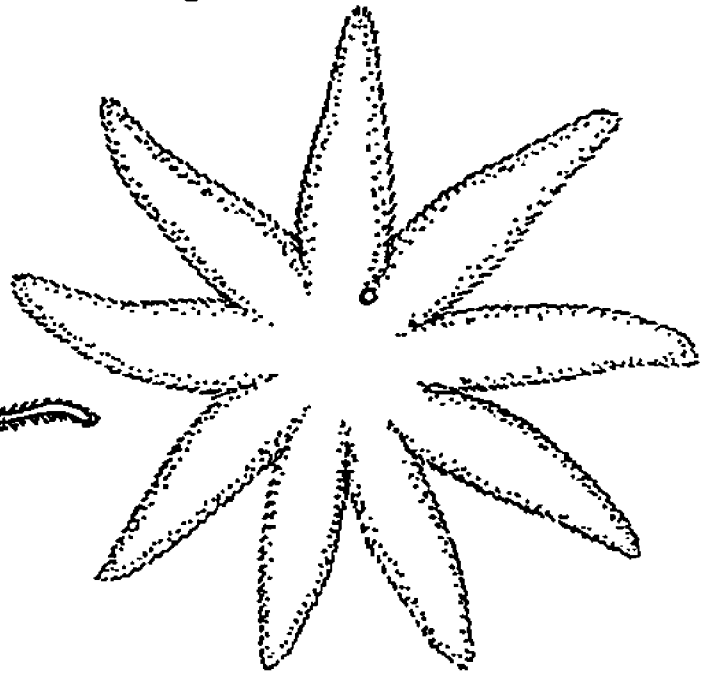

Empty Test

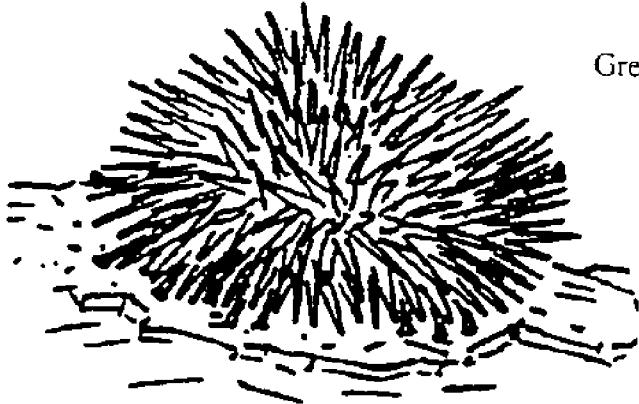

Green Sea Urchin

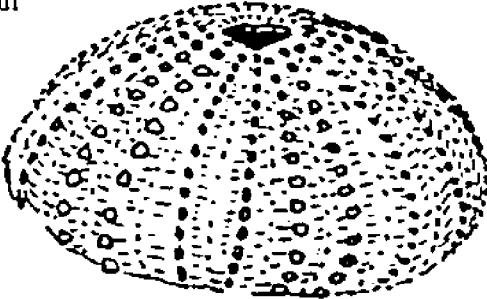

Sea Cucumber

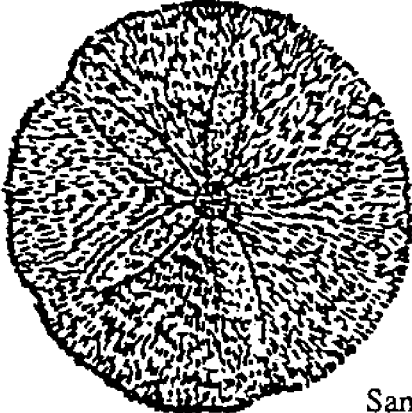
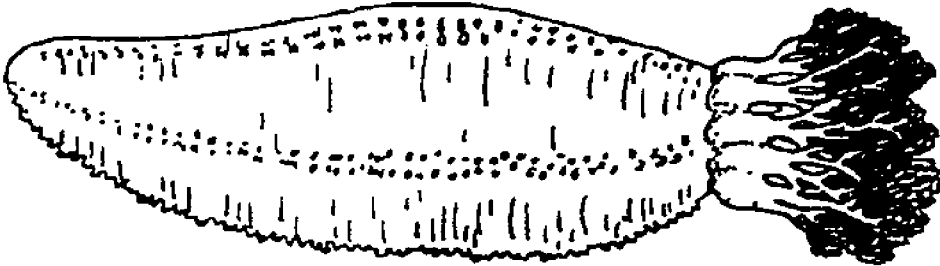

Sand Dollar



Rat-tailed Cucumber

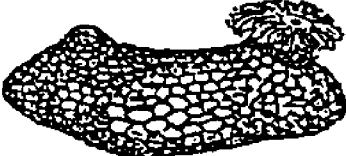

Scarlet Psolus



Common Periwinkle

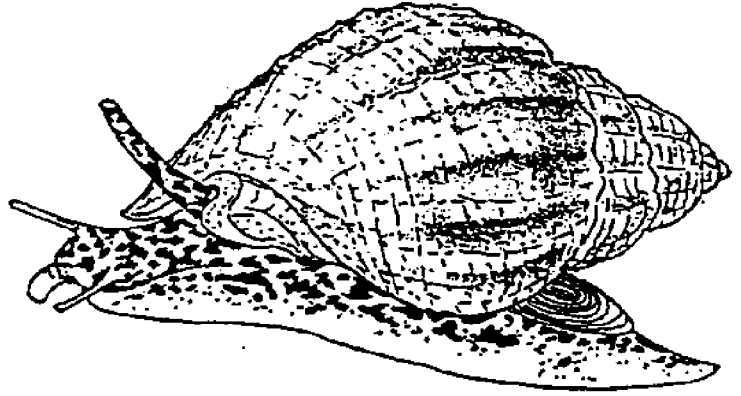
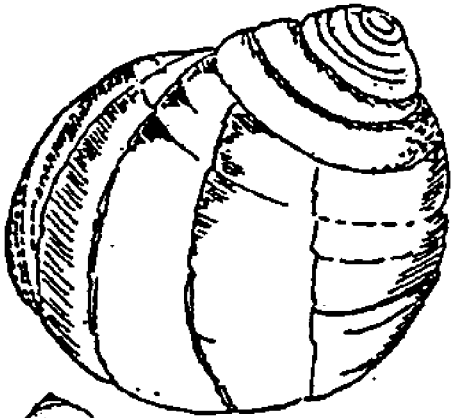

Waved Whelk



Smooth Periwinkle



American Oyster

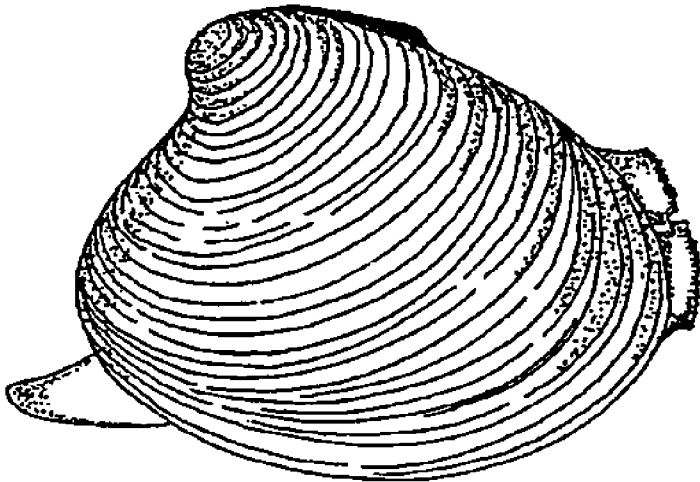
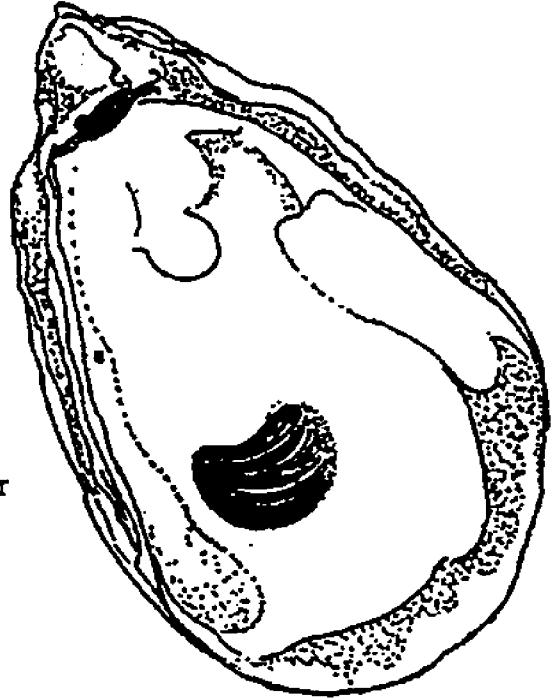

Quahog

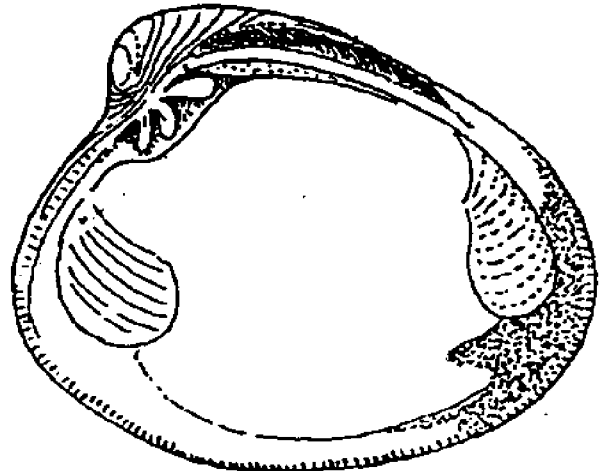

Soft-Shell Clam

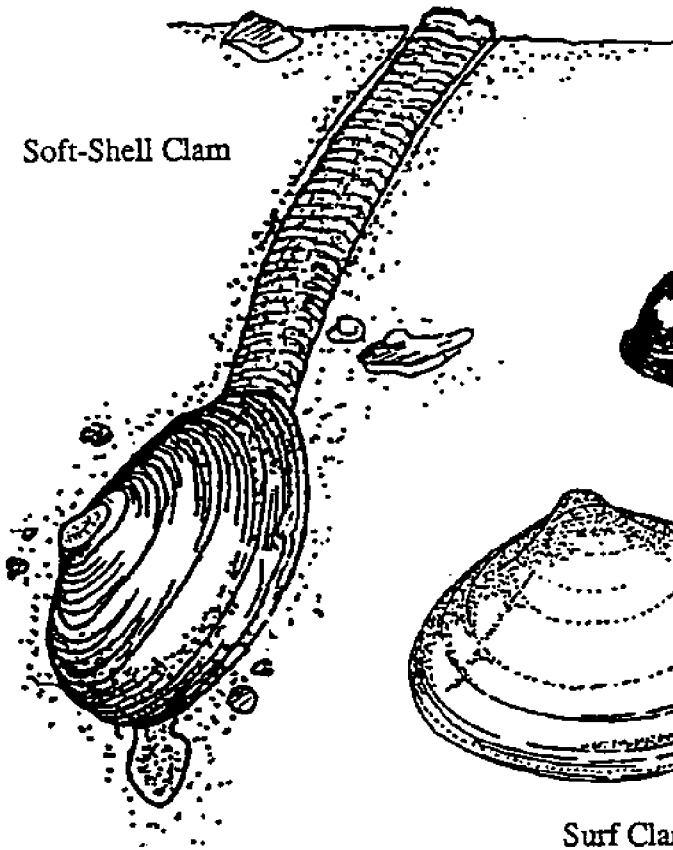

Horse Mussel

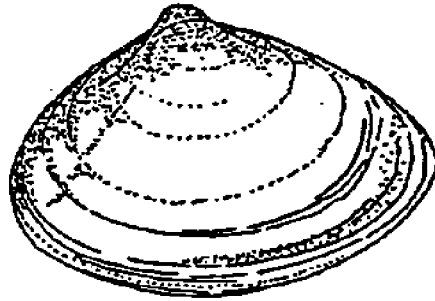
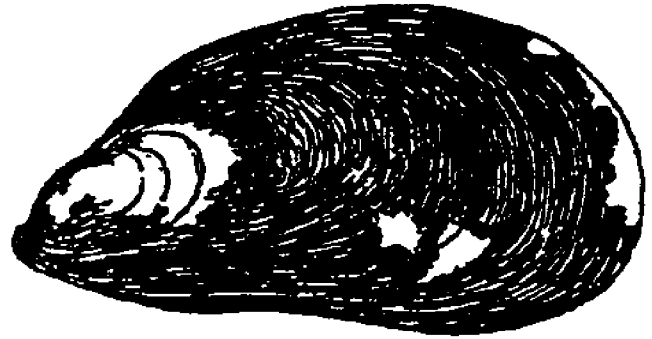

Surf Clam



Razor Clam

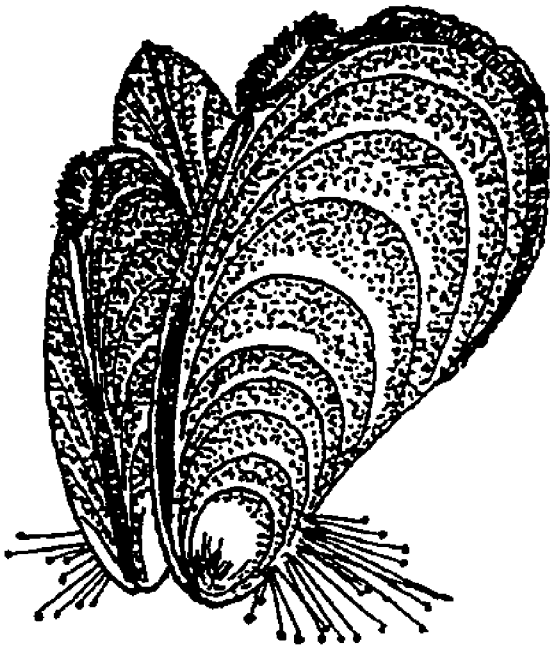

Blue Mussel

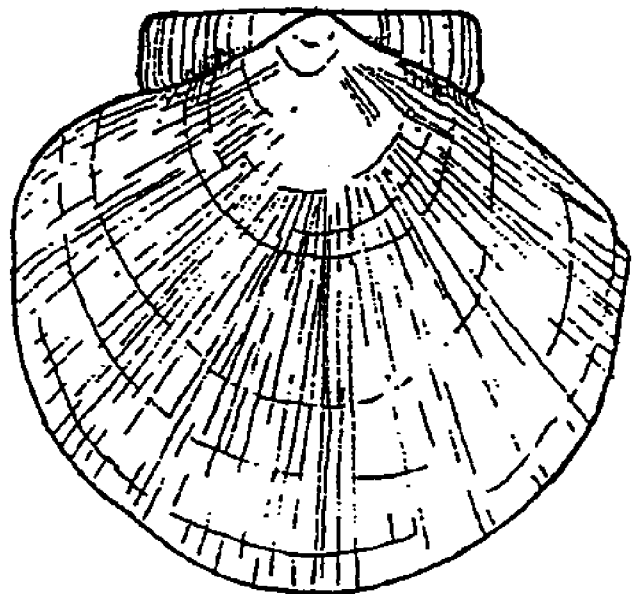

Scallop

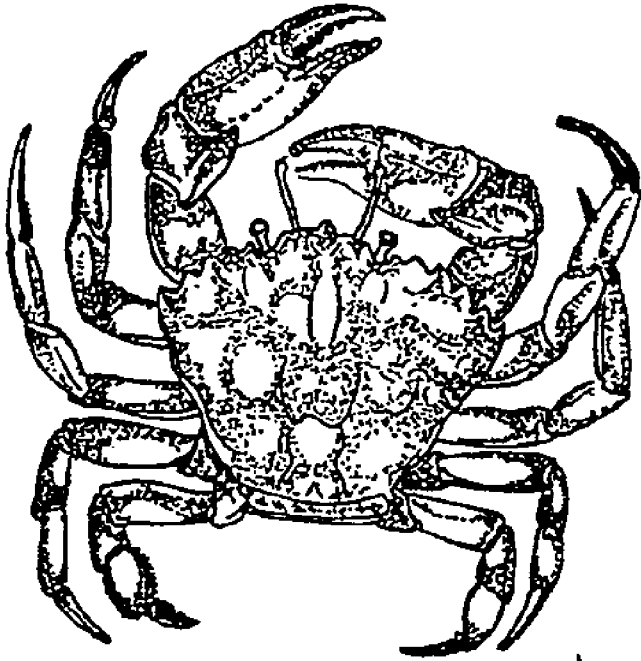

Green Crab

Rock Crab

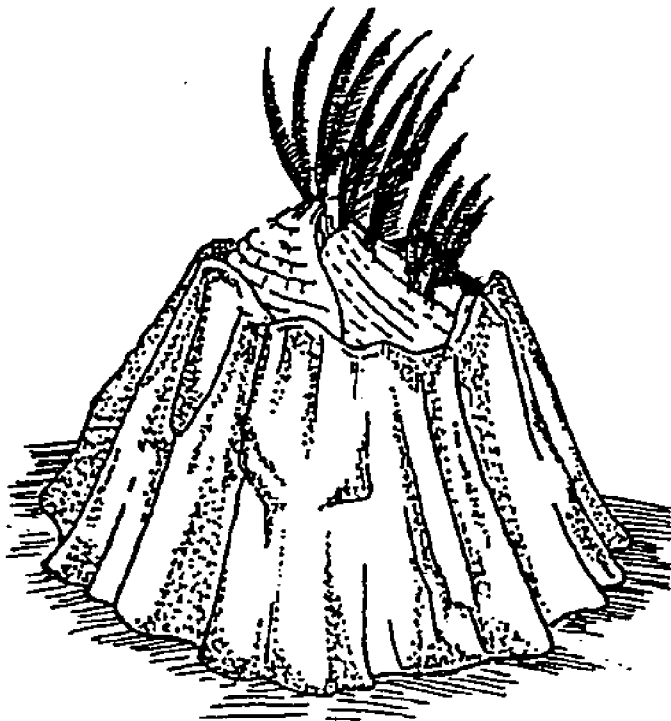
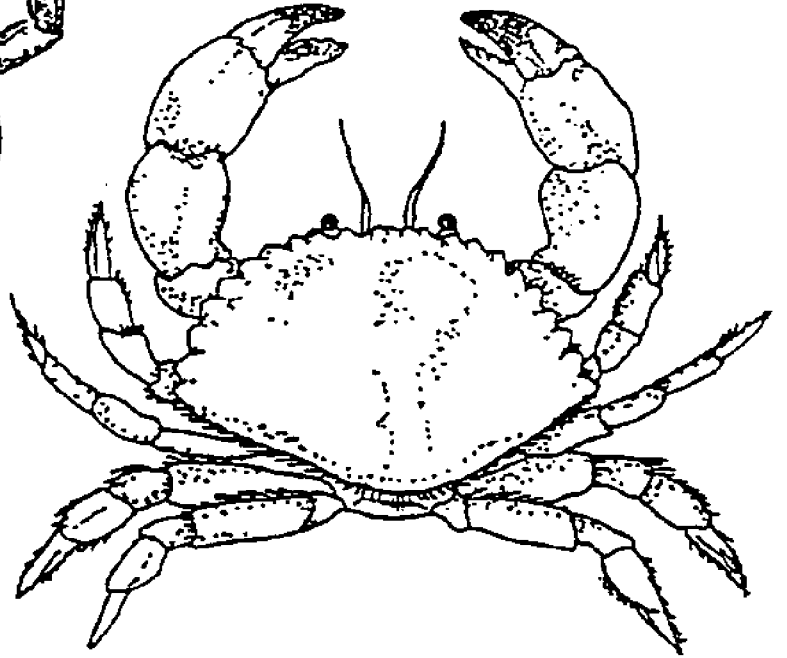

Northern Rock Barnacle

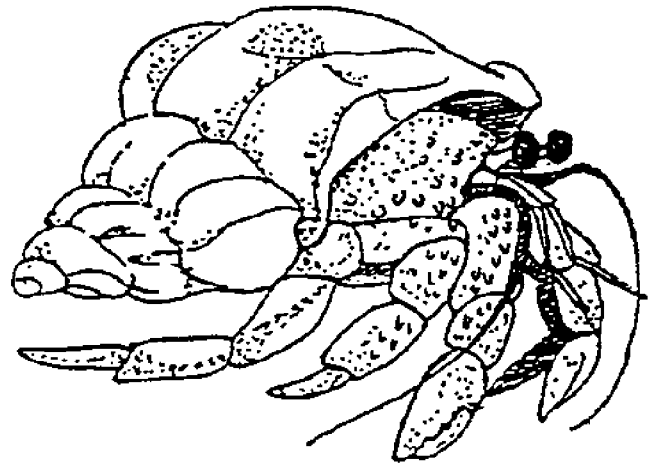

Hermit Crab

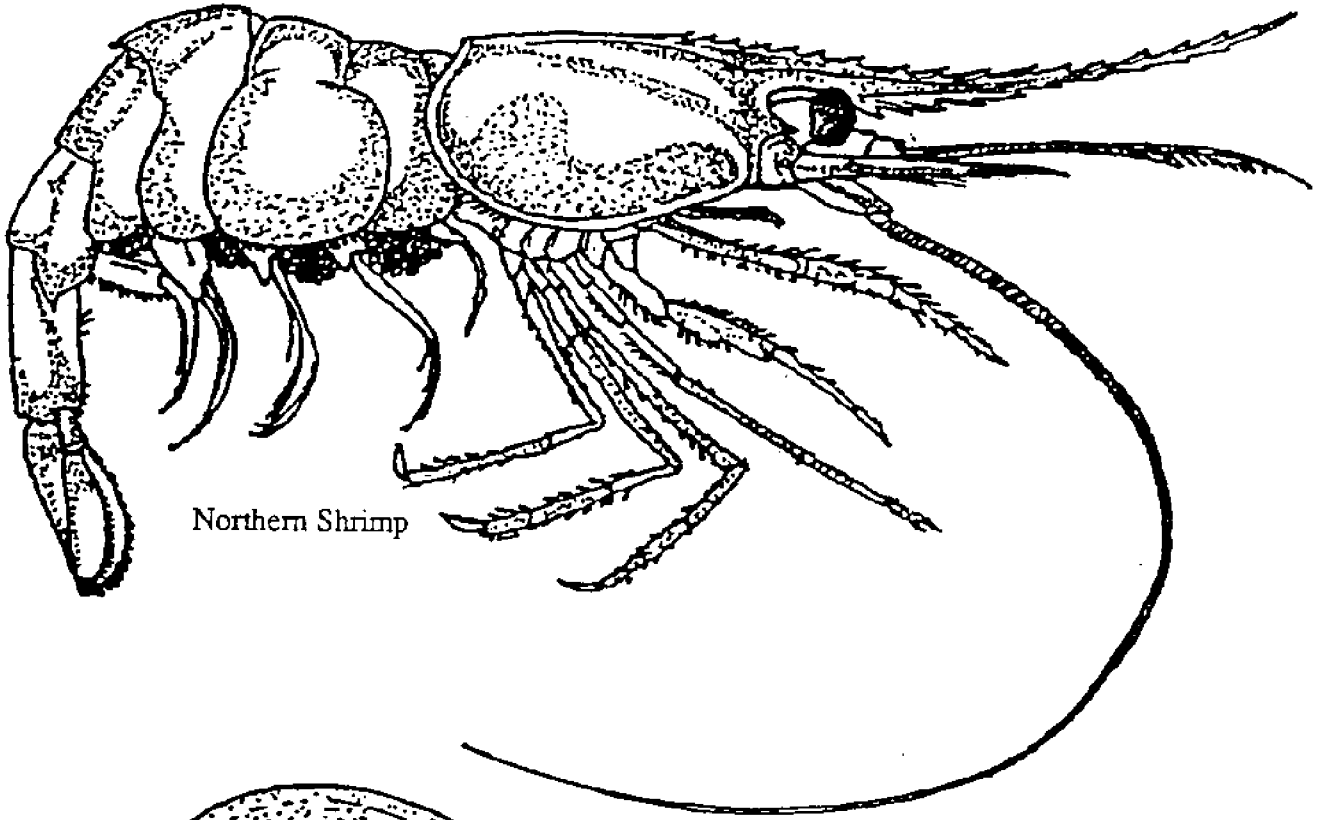

Northern Shrimp

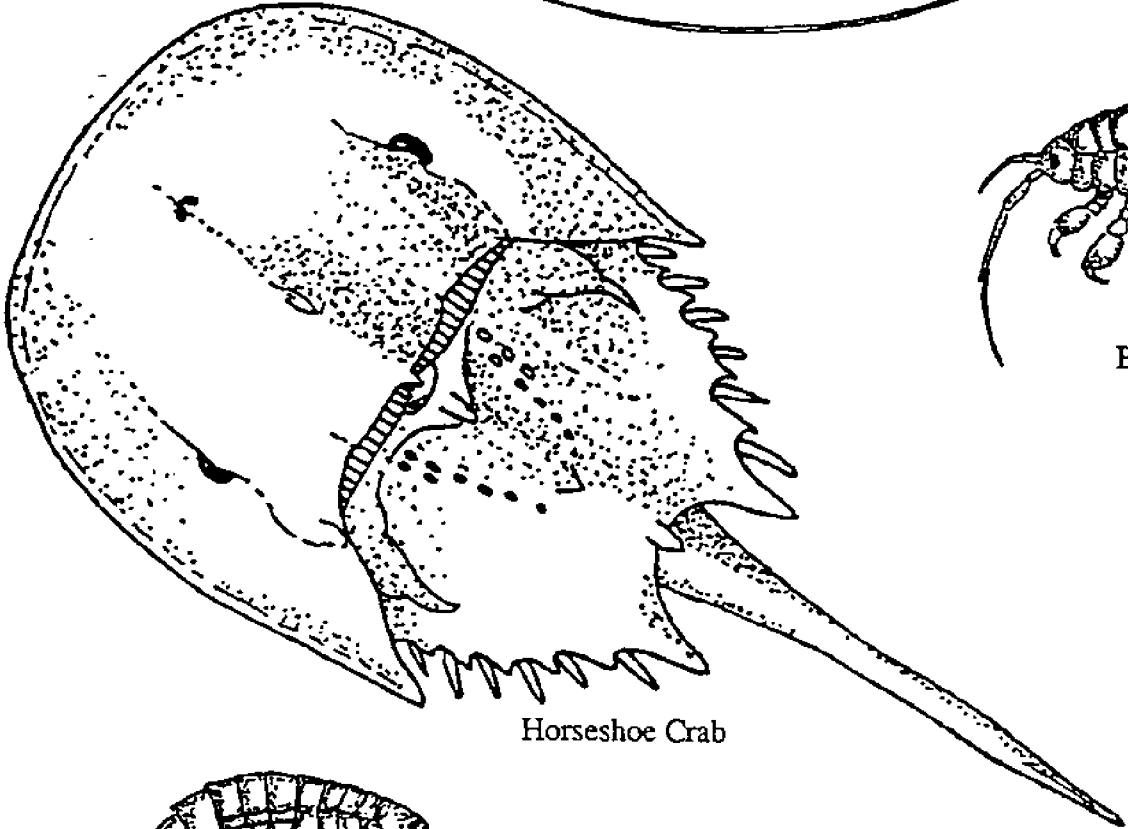

Horseshoe Crab

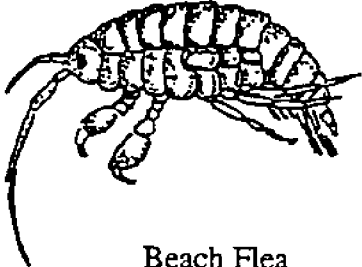

Beach Flea

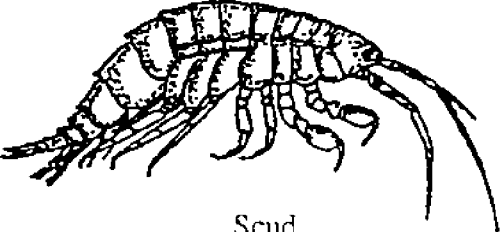

Scud

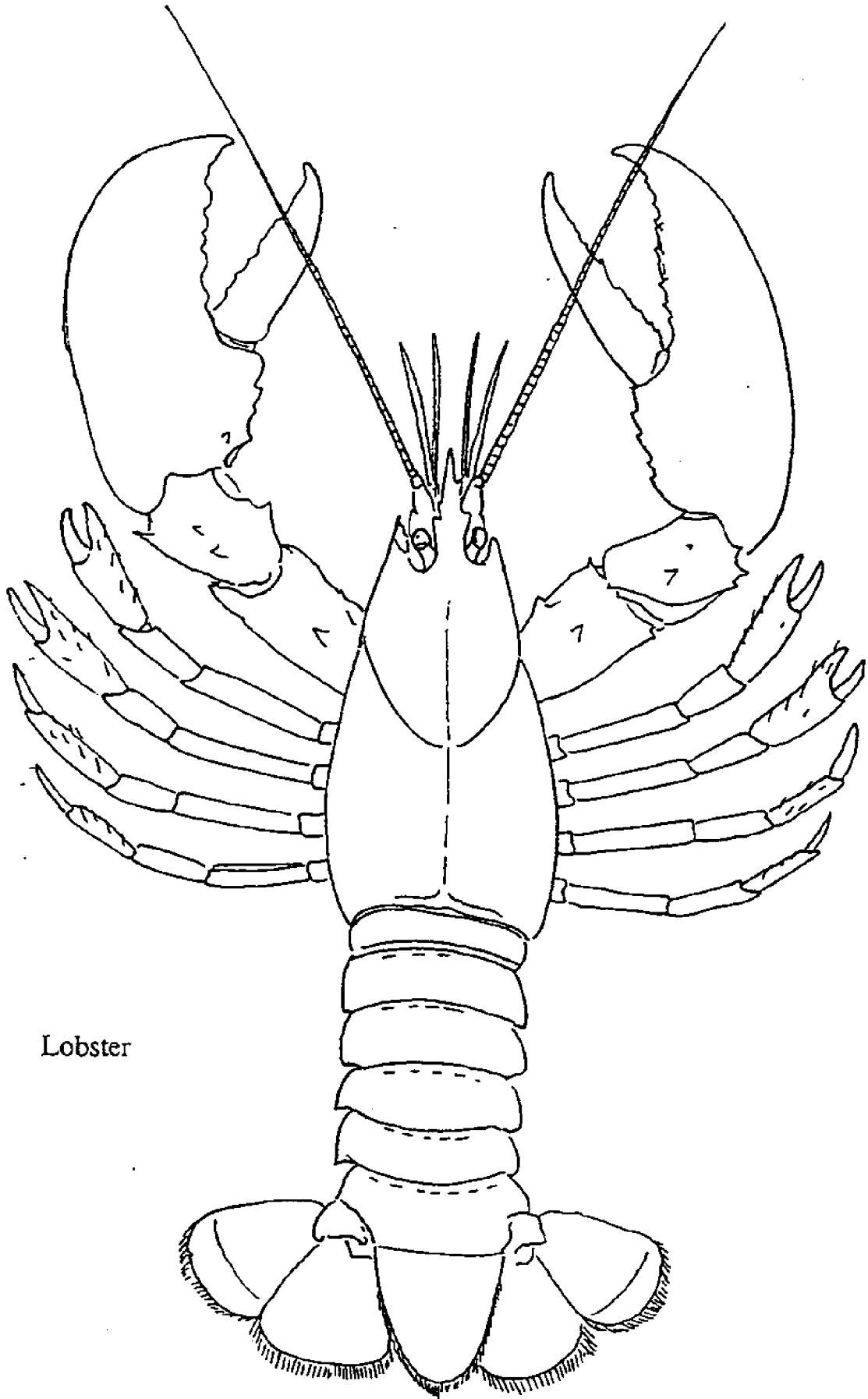

Lobster

Mackerel

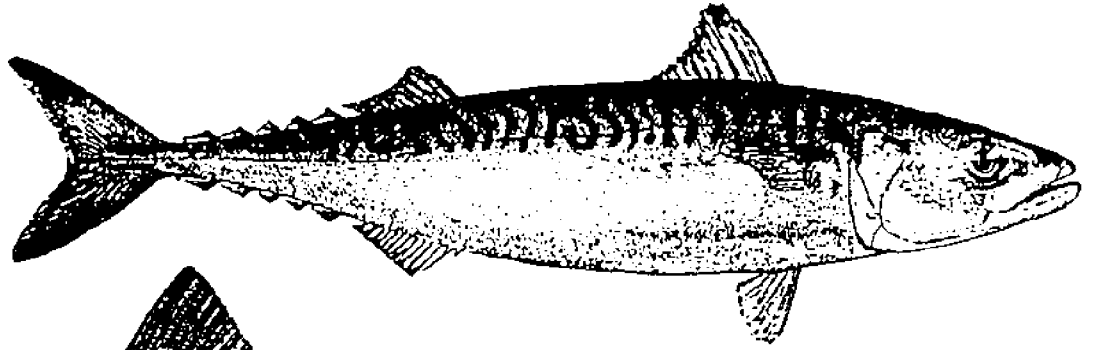

Alewife

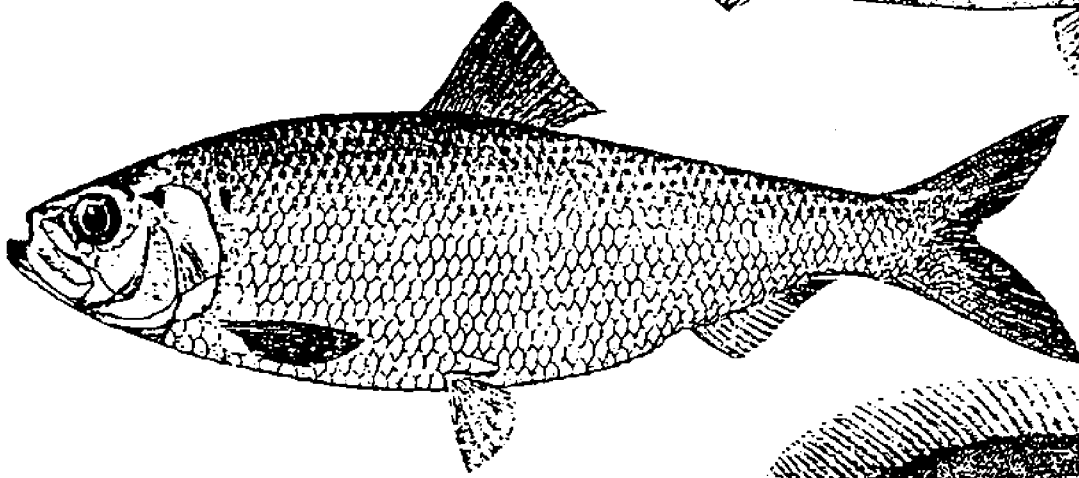

Flounder

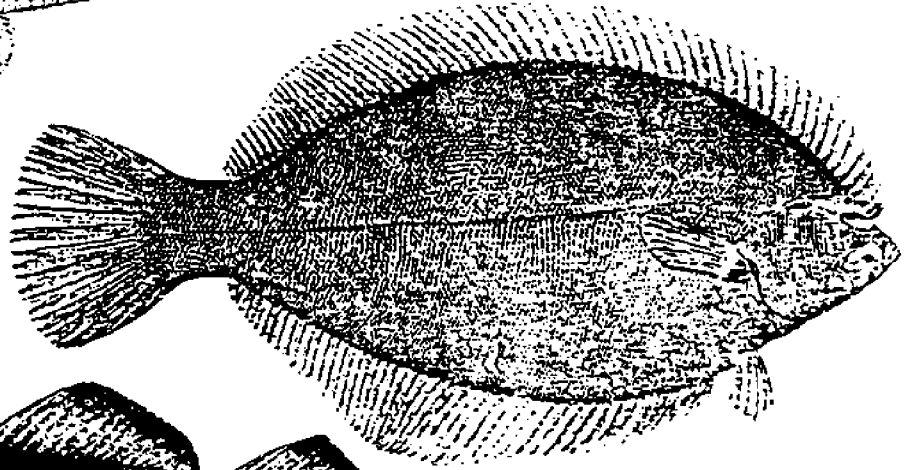

Cod

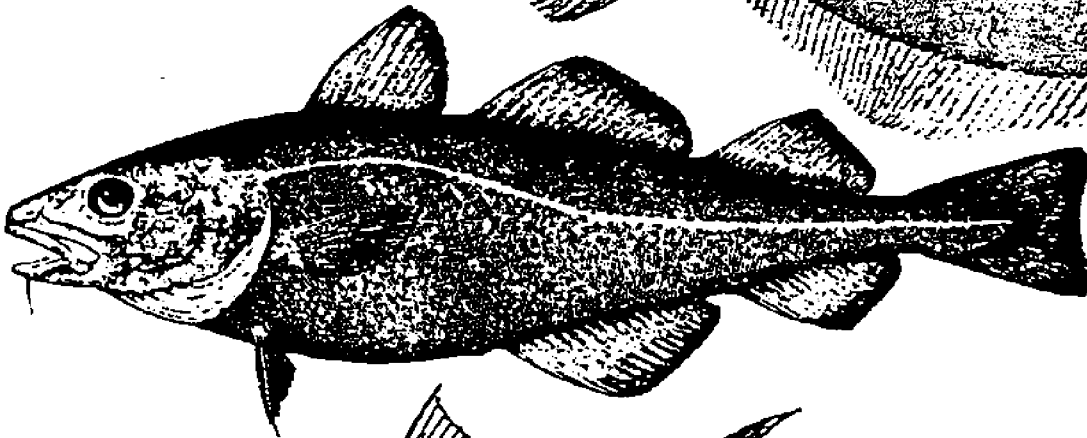

Bluefin Tuna

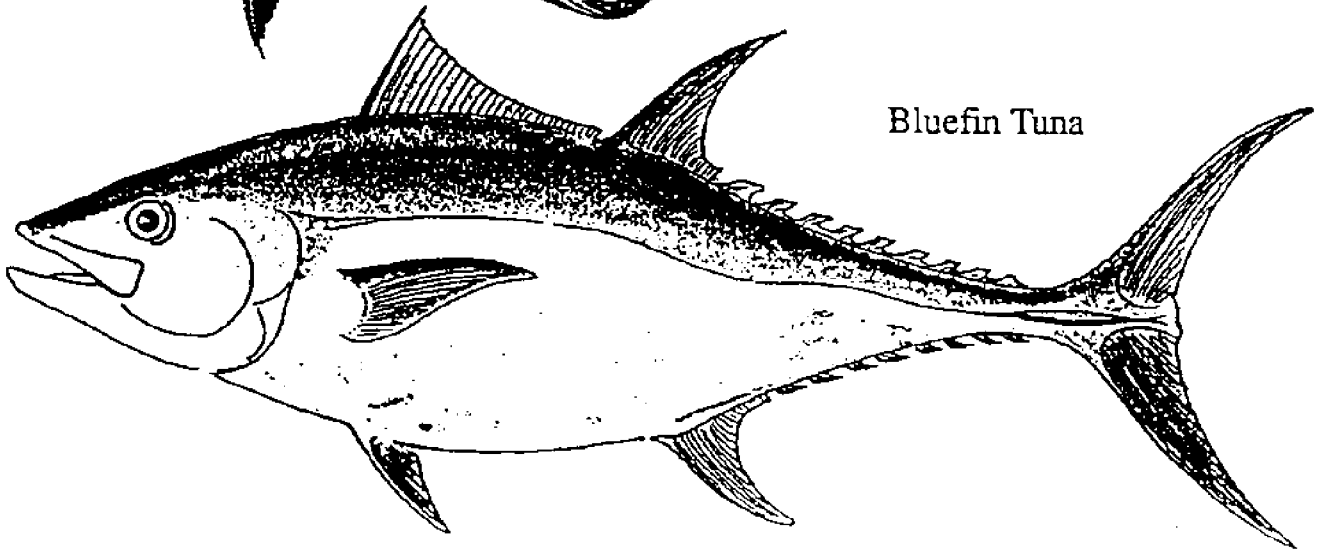

APPENDIX C

Field Trip to a Rocky Shore

(Reprinted with permission from University of Maine Cooperative Extension and Northern New England Marine Education Project.)

Welcome to the Maine coast. While some flat, sandy beaches do exist in Maine, the major part of the coast is rugged and rock-lined. It is clearly described by Howard M. Weiss and Michael W. Dorsey in their book *Investigating the Marine Environment*:

"The rocky shore is a severe and rugged environment. It is battered by surf and covered by salty water with each incoming tide and during storms. The rest of the time it is exposed to the heat and radiation of the sun, to icy winds, to rain and snow, and to the blistering heat of summer and the bitter cold of winter. The plants and animals that live here must be as rugged as this environment.

"Rocky shore organisms must be able to hold tight to sheer rocks to keep from being washed away. They must resist abrasion as they are scraped by rocks and bounced about by the turbulent water. They must be able to withstand exposure to salty sea water and fresh rainwater and other changes that occur as the tide rises and falls.

"In certain places the rocks form basinlike depressions that hold water as the tide recedes. Conditions in these basins, or tide pools, are harsh and

unpredictable. When they are exposed to air, the sun can heat them up to the temperature of a warm tub. The sun's heat evaporates the water, increasing the salinity (salt content) higher than that of the open ocean. When it rains, the basin is filled with fresh water, and the salinity can drop to zero. Although the rocky intertidal zone is a harsh environment, a surprisingly large number of different plants and animals live there.

"Within a short distance, the environment on the rocky shore changes from completely marine to completely terrestrial. This makes it an ideal place to study how the distribution of animals is affected by the environment. The organisms living near the low-tide level on a rocky shore are immersed in sea water almost all the time, whereas the organisms living higher up are inundated only at high tide. Different plants and animals tolerate the conditions found at different locations between the tidal levels. Groups of organisms that tolerate similar conditions will generally occupy bands or zones along the shore. As you walk from the land toward the water, you will pass over a number of zones containing different groups of organisms."

On most rocky shores the following areas can be identified:

Above the tide – a transitional area extending from the forest down to the spray zone.

Spray zone – a black or greyish band found above high tide which sea water reaches regularly by splash or spray action; the black color is caused by the presence of millions of microscopic, individual blue-green algae.

High tide mark - a line along the shore caused by the uppermost rise of sea water on a given day; this line varies considerably due to storms, the monthly cycle of the moon, and the annual cycle of the sun.

Rockweed or intertidal zone - a yellowish-brown band found between the high and low tide marks which is alternately exposed to air and covered by sea water each day; organisms common in the zone include rockweeds, barnacles, periwinkles, blue mussels, and dog whelks; barnacles often form a distinctive white band between the black splash zone and the rockweeds.

Tide pools – places among the rocks between high and low tide marks where seawater is trapped each time the tide goes out.

Irish moss zone – a belt of vegetation found below the rockweed zone and near the low tide mark; this zone is dominated by Irish moss and other red algae.

Low tide mark – a line along the shore created by the farthest drop of sea water on a given day; as with the high tide mark, this line varies with storms and the cycles of the moon and sun.

Kelp or subtidal zone - a band of vegetation located right at or below the low tide mark; common organisms include kelp, sea stars, sea urchins, and sea cucumbers.

1. Howard M. Weiss and Michael W. Dorsey, *Investigating the Marine Environment: A Sourcebook. Volume I: Field Studies* (Groton, CT: Project Oceanology, 1980), pp. 37-38

Following is an activity that will help you locate these various zones and the organisms that live in each. Included is a Field Guide to the Organisms found along the shore to help you identify them. Also helpful is the chart on Rocky Beach Survival which follows the Field Guide.

ZONATION ALONG A ROCKY SHORE

Purpose: To study the zonation of plants and animals living along a rocky shore.

Introduction: The rocky shore is a severe and rugged environment. It is battered by surf and covered by salty water with each incoming tide and during storms. The rest of the time it is exposed to the heat and radiation of the sun, to icy winds, to rain and snow, and to the blistering heat of summer and the bitter cold of winter. The plants and animals that live here must be as rugged as this environment. Within a short distance, the environment on the rocky shore changes from completely marine to completely terrestrial. This makes it an ideal place to study how the distribution of animals is affected by the environment.

Materials and equipment needed:

Pail for collections
Coat hangers bent into square shape
30 yard line marked at 2 yard intervals
Data sheets or notebook
Clip board
Pencil
Field Guide
Hand lens (optional)

Procedure:

- Plan to arrive at the shore at about one or two hours before low tide.
- Divide your group into teams of three persons (recorder, investigator, researcher).
- Starting at the edge of the woods or landward side of the beach, stretch out the transect line at about a right angle to the beach. Place the hanger square (quadrat frame) next to the uppermost marking on the transect line. Place number "1" under quadrat number on the data sheet.
- Using your Field Guide, identify all the plants and animals that you can which fall inside the quadrat frame. List these on your data sheet.
- Complete the rest of the information requested on the data sheet: approximate number of each type of organism; description of the environment (rocks, sand, sunny) estimate the elevation above or below the high tide mark and the zone in which your quadrat is located (spray zone, tidal pool, rockweed zone).
- Continue toward the water using the same procedure for each quadrat. Move the transect line when you reach the end to form a straight line toward the water. Continue until you reach the low tide mark.
- When you have finished your transect, go back and study in detail the plants and animals you found to discover how they survive. For each organism list: how it survives the crashing waves, how it protects itself from drying, where it lives (niche), and how it gets food. Record these observations on the Rocky Beach Survival Data Sheet.
- After returning home, prepare a map showing the location of each quadrat along the transect line. Show the location of the high tide mark, low tide mark, and the different zones. Make up symbols for the different organisms you found, such as

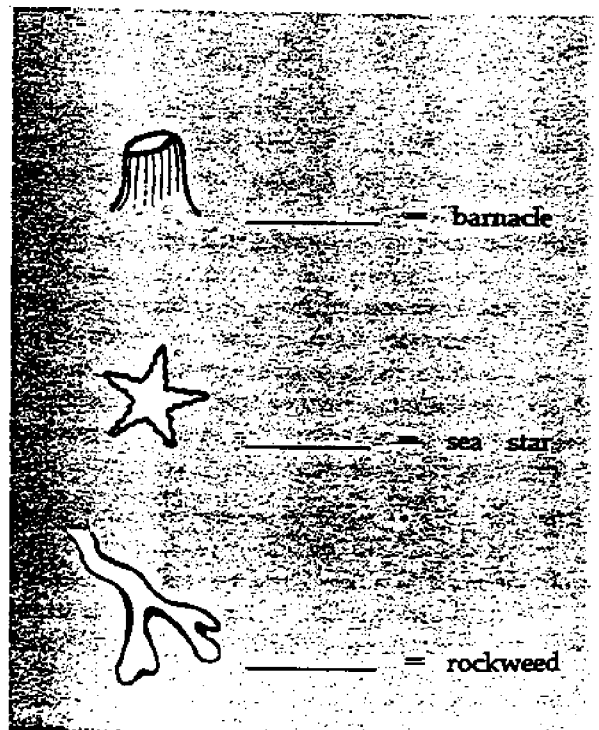

Fill in your map with the symbols for the dominant organisms found in each zone.

Zonation Along a Rocky Shore
Data Sheet

Your Name _____
Transect # _____
Date _____

Quadrat Number	Animals	Approx. Number	Plants	Approx. Number	Zone	Environment (rock, sand, etc.)	Elevation (Feet above or below high tide mark)

Our Seashore Life

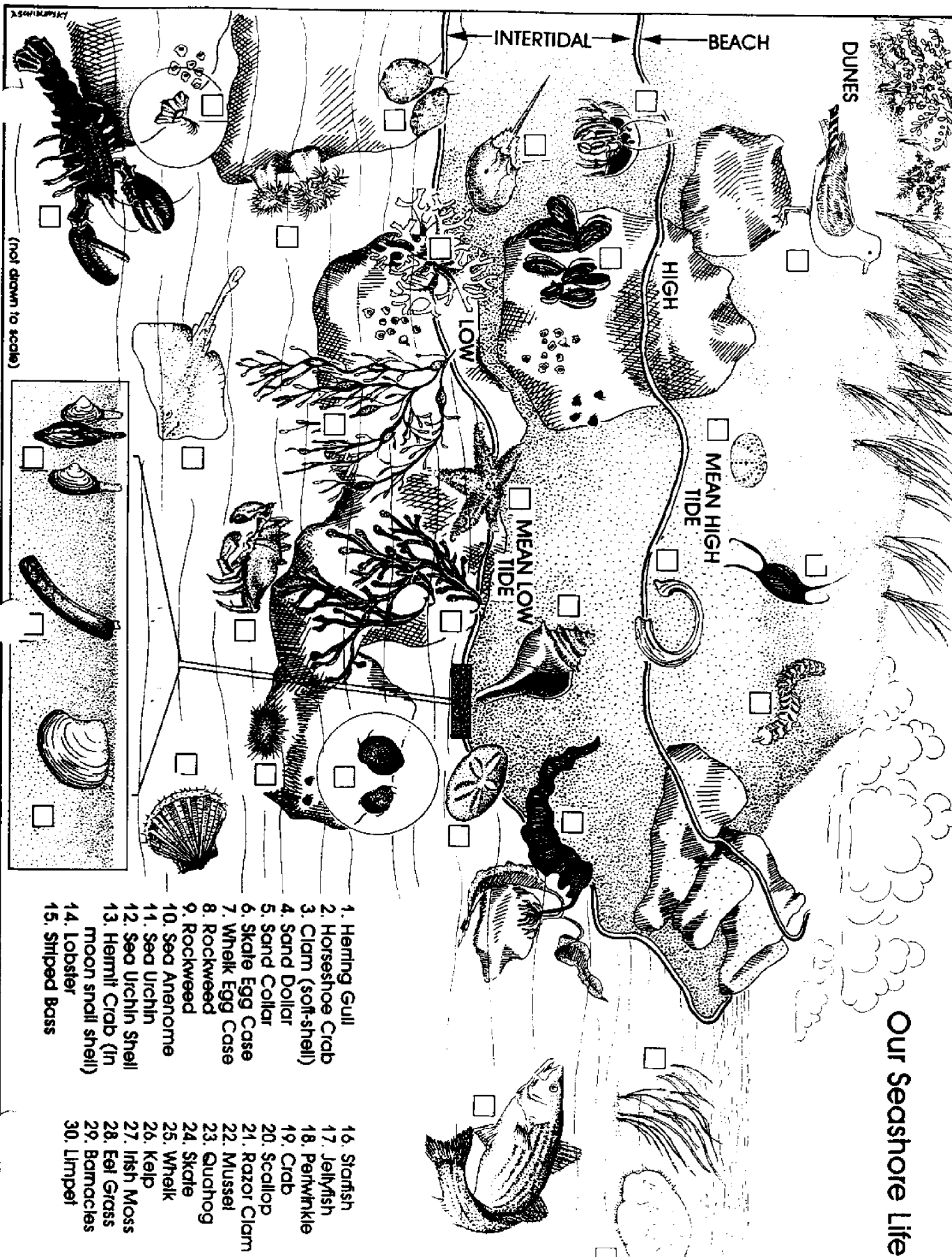

- 1. Herring Gull
- 2. Horseshoe Crab
- 3. Clam (soft-shell)
- 4. Sand Dollar
- 5. Sand Collar
- 6. Skate Egg Case
- 7. Whelk Egg Case
- 8. Rockweed
- 9. Rockweed
- 10. Sea Anemone
- 11. Sea Urchin
- 12. Sea Urchin Shell
- 13. Hermit Crab (In moon snail shell)
- 14. Lobster
- 15. Striped Bass

- 16. Stormfisk
- 17. Jellyfish
- 18. Periwinkle
- 19. Crab
- 20. Scallop
- 21. Razor Clam
- 22. Mussel
- 23. Quahog
- 24. Skate
- 25. Whelk
- 26. Kelp
- 27. Irish Moss
- 28. Eel Grass
- 29. Barnacles
- 30. Limpet

(not drawn to scale)

© 1995

Our Seashore Life (Answers)

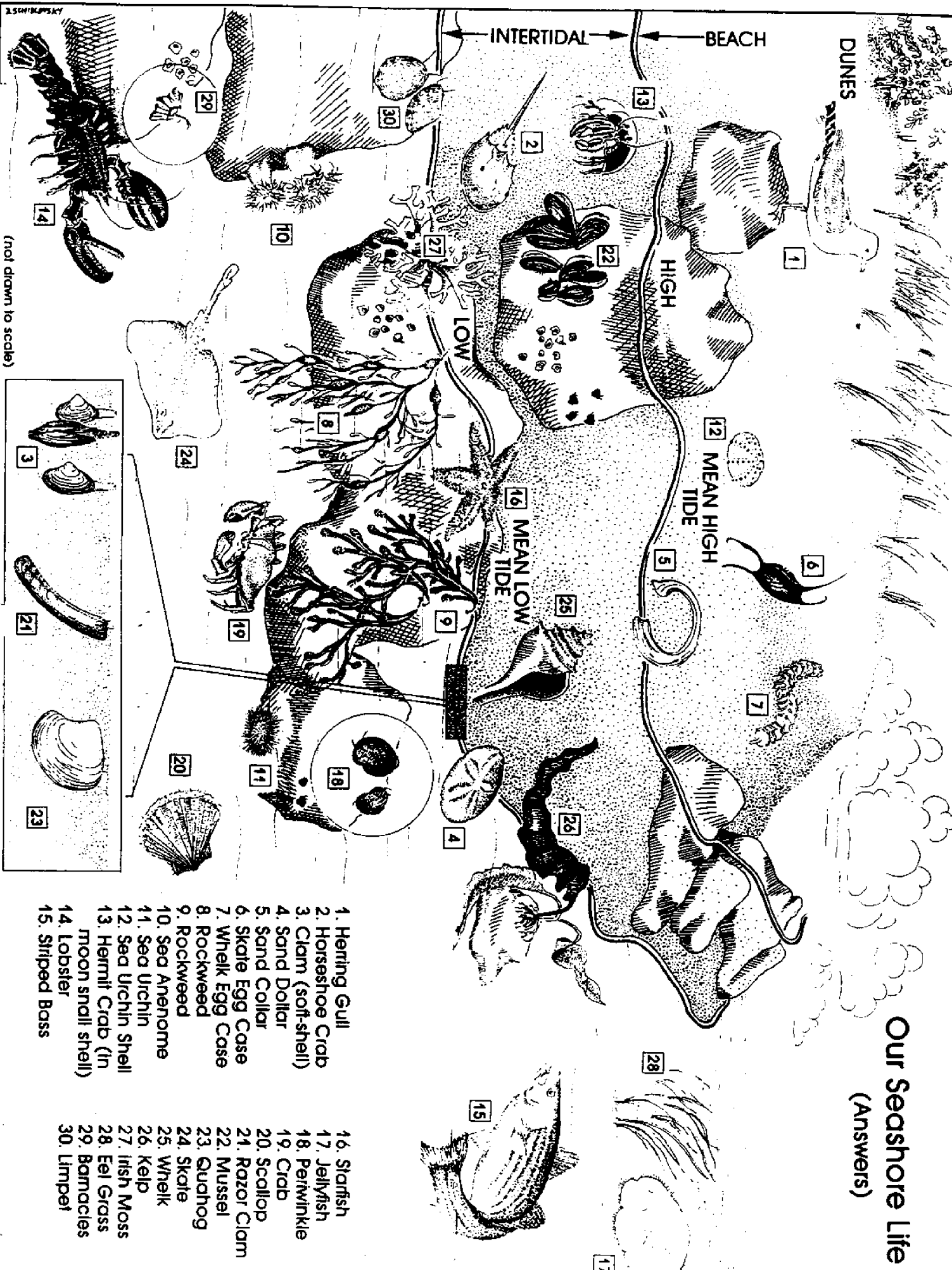

- | | |
|---------------------------------------|----------------|
| 1. Herring Gull | 16. Starfish |
| 2. Horseshoe Crab | 17. Jellyfish |
| 3. Clam (soft-shell) | 18. Periwinkle |
| 4. Sand Dollar | 19. Crab |
| 5. Sand Collar | 20. Scallop |
| 6. Skate Egg Case | 21. Razor Clam |
| 7. Whelk Egg Case | 22. Mussel |
| 8. Rockweed | 23. Quahog |
| 9. Rockweed | 24. Skate |
| 10. Sea Anemone | 25. Whelk |
| 11. Sea Urchin | 26. Kelp |
| 12. Sea Urchin Shell | 27. Irish Moss |
| 13. Hermit Crab (in moon snail shell) | 28. Eel Grass |
| 14. Lobster | 29. Barnacles |
| 15. Striped Bass | 30. Limpet |

(not drawn to scale)

APPENDIX D

Adaptations to Survive on a Rocky Beach

(Reprinted with permission from University of Maine Cooperative Extension.)

ROCKY BEACH SURVIVAL
Data Sheet

Your Name _____
Date _____

Instructions: List the plants and animals found along the rocky shore. Examine and list how each survives.

PLANT OR ANIMAL	WAVE SURVIVAL	PROTECTION FROM DRYING	NICHE	METHOD OF FEEDING
<p>Example: Barnacle</p>	<p>attaches to rocks</p>	<p>closes shell tightly</p>	<p>rocks</p>	<p>opens shell, hand-like structure strains food from the water</p>

ROCKY BEACH SURVIVAL
The Irish Moss Zone

ORGANISM	WAVE SURVIVAL	PROTECTION FROM DRYING	METHOD OF FEEDING
anemone	attaches to rocks	withdraws tentacles; covers with shell bits	catches food with tentacles
crumb of bread sponge	encrusts rocks	tidal pools; subtidal	passes water through tiny holes; traps food in- side
fan worm	burrows into mud	burrows into mud	catches food with tentacles
sand dollar	lies flat against sand	hard shell; subtidal	cilia move food into mouth
sand shrimp	burrows into sand; free swimming	tidal pools; subtidal	strains food through stiff bristles
sea cucumber	clings to rocks with tubular feet	tidal pools; subtidal	takes in organic debris with mop-like branches or tentacles
sea star	tube feet act as suction cups for clinging	crawls into moist crevices; forms clusters	open bivalve shells with tube feet; extends stomach into shell
sea urchin	tube feet act as suction cups for clinging	crawls into rocky crevices	tube feet catch food; move under to mouth with tiny feet
slipper shell	holds onto rocks with muscular foot	clamps onto rocks	mouth, located in front of foot, scrapes tiny plants off rocks
squirt	embedded in jelly-like substance	tidal pools; subtidal	siphons water through body; traps food inside
jellyfish	free swimming	kelp zone; subtidal	catches plankton on sticky bands of umbrella; licks off with mouth arms

ROCKY BEACH SURVIVAL
The Rockweed Zone

ORGANISM	WAVE SURVIVAL	PROTECTION FROM DRYING	METHOD OF FEEDING
blood worm	burrows into mud	burrows into mud	catches food with hook-like jaws
clam worm	burrows into mud	burrows into mud	catches food with horny protruding jaw
tube worm	attaches to rocks and seaweed	pulls plume into tube; has plug for end	catches food with plume
barnacle	attaches to rocks	closes shell tightly	opens shell; hand-like structure strains food
beach flea	above high tide mark	crawls under seaweed	through mouth; scavenger
chiton	holds onto rocks with muscular foot	clamps onto rocks	mouth, located in front of foot, scrapes tiny plants off rocks
clam	burrows into mud	closes shell tightly	pumps water through shell to filter food
dog whelk	holds onto rocks with muscular foot	clamps onto rocks	rasps prey with file-like mouth part
dog winkle	holds onto rocks with muscular foot	closes shell tightly	rasps or drills into mussels or other shelled animals
limpet	holds onto rocks with muscular foot	clamps onto rocks trapping water under shell; forms clusters in sheltered spots	mouth, located in front of foot, scrapes tiny plants off rocks
mussel	attaches to rocks with byssus threads	closes shell tightly	pumps water through shell to filter food
periwinkle	holds onto rocks with muscular foot	clamps onto rocks; retreats into shell	rasps seaweed with tiny file-like mouth part
rock crab	crawls under rocks	crawls to moist areas under rocks	uses claws to scavenge
hermit crab	crawls under rocks	pulls into shell; crawls to wetter area	uses claws to scavenge

APPENDIX E
Field Guide to Seaside Plants & Coastal Organisms

(Reprinted with permission from University of Maine Cooperative Extension.)



Bayberry
Myrica pennsylvanica
 2-4' shrub, glossy leaves, grey-white, waxy nuts;
 shores, edge of woods

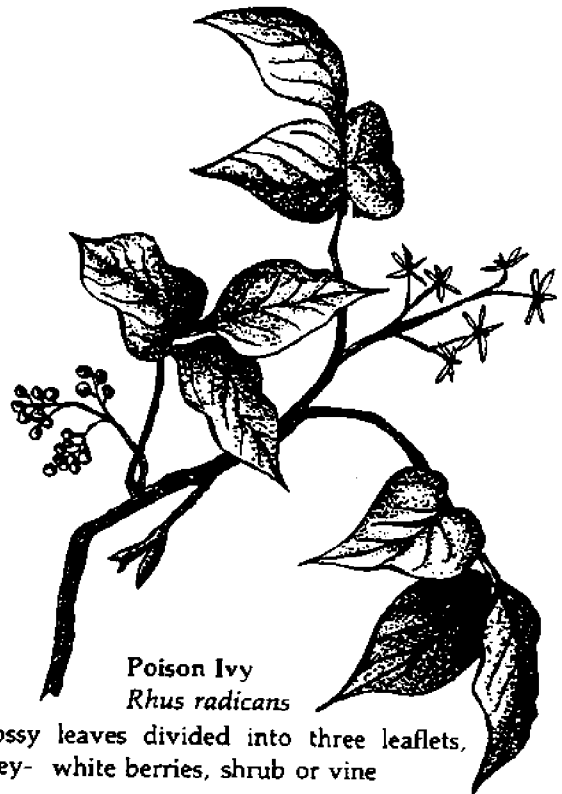

Poison Ivy
Rhus radicans
 glossy leaves divided into three leaflets,
 grey- white berries, shrub or vine



Rugosa Rose
Rosa rugosa
 shrub, large pink or white flower in July to Oc-
 tober, bright orange, rose hips, thorny stems



White Spruce
Picea glauca
 tree, bluish-green needles $\frac{1}{2}$ - $\frac{3}{4}$ " long, pungent
 odor when crushed, twigs *not* downy or hairy,
 edge of woods

**Juniper***Juniperus communis*

shrub, needles in whorls of three, one side white, blue-black berries with white powder, edge of woods

**Bearberry***Arctostaphylos uva-ursi*

creeping evergreen shrub, flowers white May-June, fruit red, forms mat on sand and rocks near ocean

**Black Crowberry***Empetrum nigrum*

small flowers, needle-like leaves, fruit black, forms mat on rocks near ocean

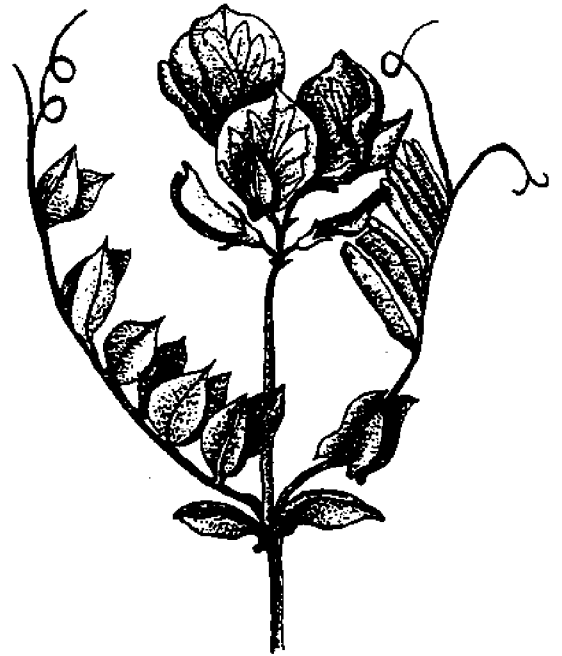
**Beach Pea***Lathyrus japonicus*

violet or purple flowers in June to September, beaches, shores



Seaside Goldenrod
Solidago sempervirens
yellow flowers in August to October, salt marshes, shores



Orach
Atriplex patula
tiny green flowers in August to October, salt marshes, shores



Sea Rocket
Cakile edentula
pale lavender blossoms in July to September, rocket-shaped seed capsule, dunes

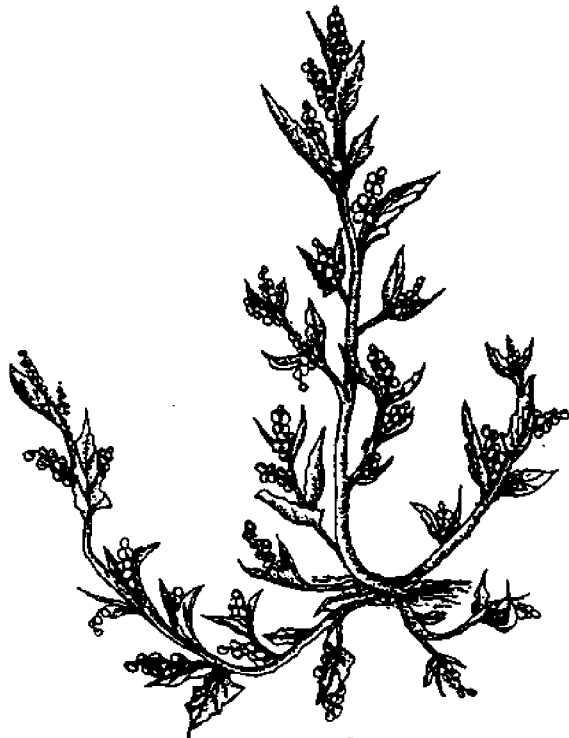

Coast Blite
Chemopodium rubrum
small red flowers in clusters in August to October, bright red in fall, salt marshes, shores

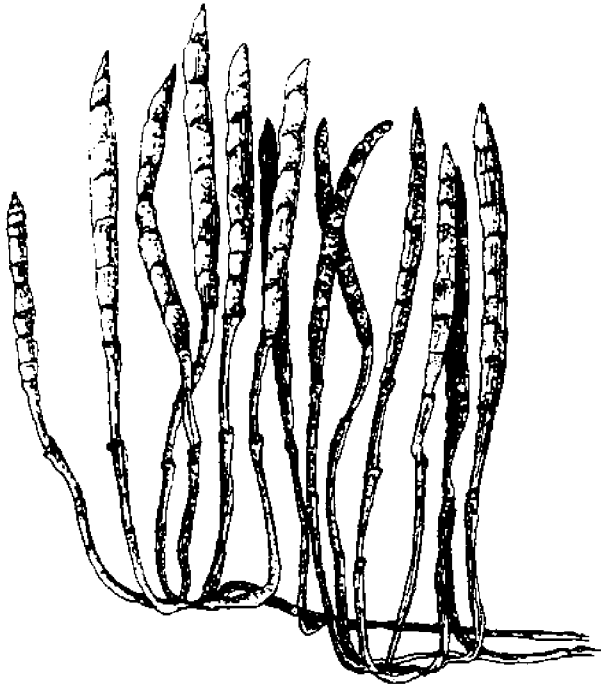

Glasswort
Salicornia sp.
 green turning orange to red in fall, succulent,
 jointed stems, mat forming in salt marshes



Seaside Plantain
Plantago oliganthos

flowers small, whitish spike, leaves linear,
 triangular in cross section, shores, salt marshes

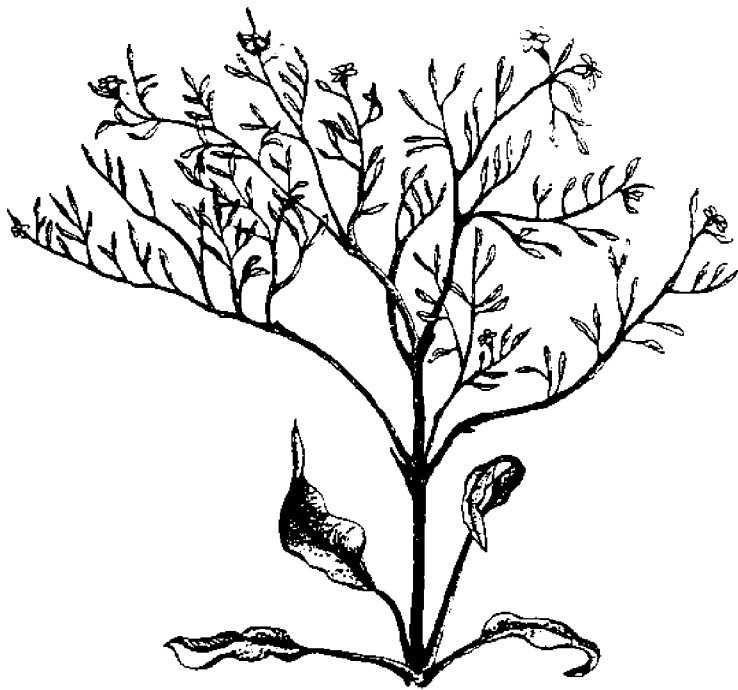

Sea Lavender
Limonium carolinianum
 light purple flowers in July to October, salt mar-
 shes



Beach Grass
Ammophila breviligulata
stems rise stiffly from
creeping rhizomes,
beaches, dunes

Chairmaker's Rush
Scirpus americanus
brown spikelets,
triangular stem, June to
September, brackish shores



Salt Marsh Grass
Spartina alterniflora
leaves flat and tough, spikelets alternating,
salt marshes and tidal creeks, roots covered
at high tide

Salt Meadow Grass
Spartina patens
touselled appearing grass, dominant plant in salt
marshes, generally above high tide mark



Spike Grass

Distichlis spicata

leaf blades curled, grows with salt meadow grass in salt marshes



Black Grass

Juncus gerardi

rush family, purple-brown seed capsule, salt marshes

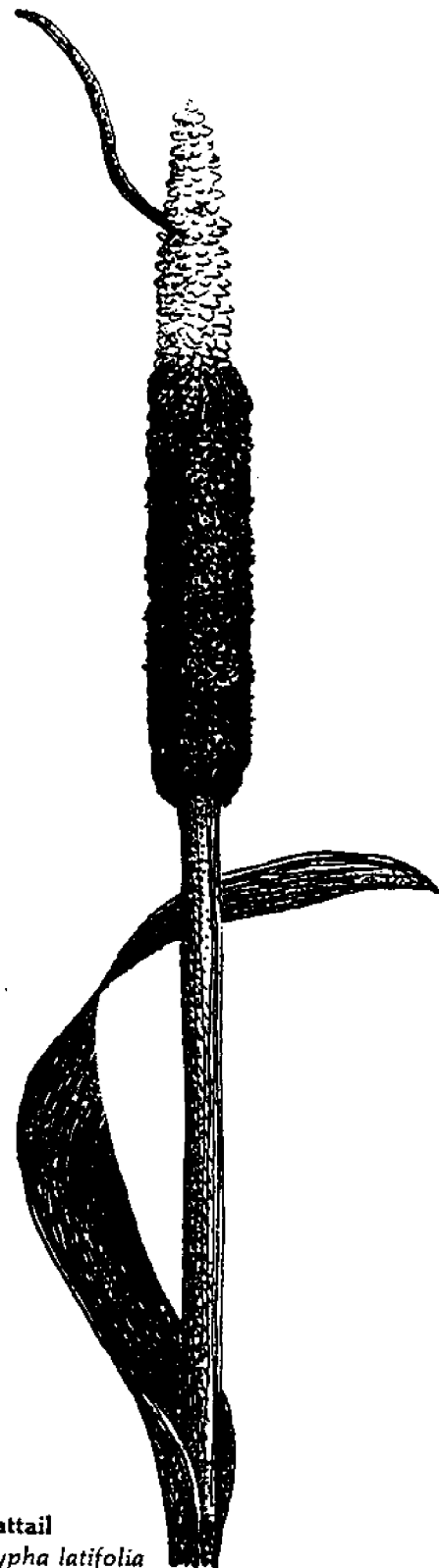

Cattail

Typha latifolia

flowers pistillate yellow (upper) and staminate brown (lower) in May to June, back of marsh in fresh water



Old Man's Beard
Usnea barbata
lichen, greyish, yellow and green, growing on branches of trees throughout year

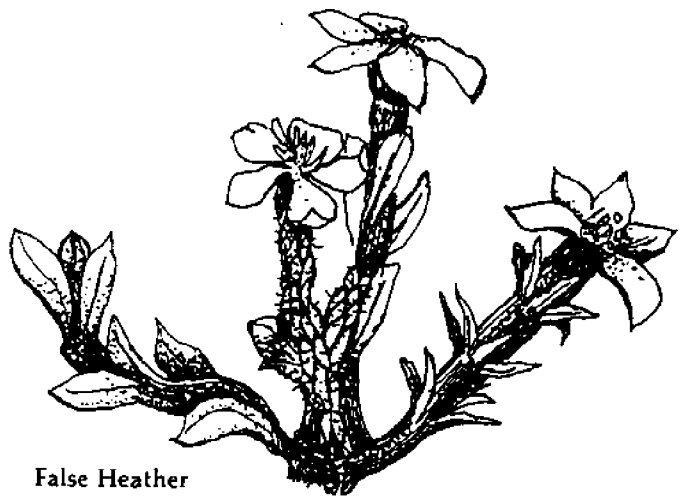

False Heather
Hudsonia tomentosa
flower bright yellow in May to July, low shrubby plant, beaches, shores



Hollow Green Weeds
Enteromorpha intestinalis
green algae, upper tide pools

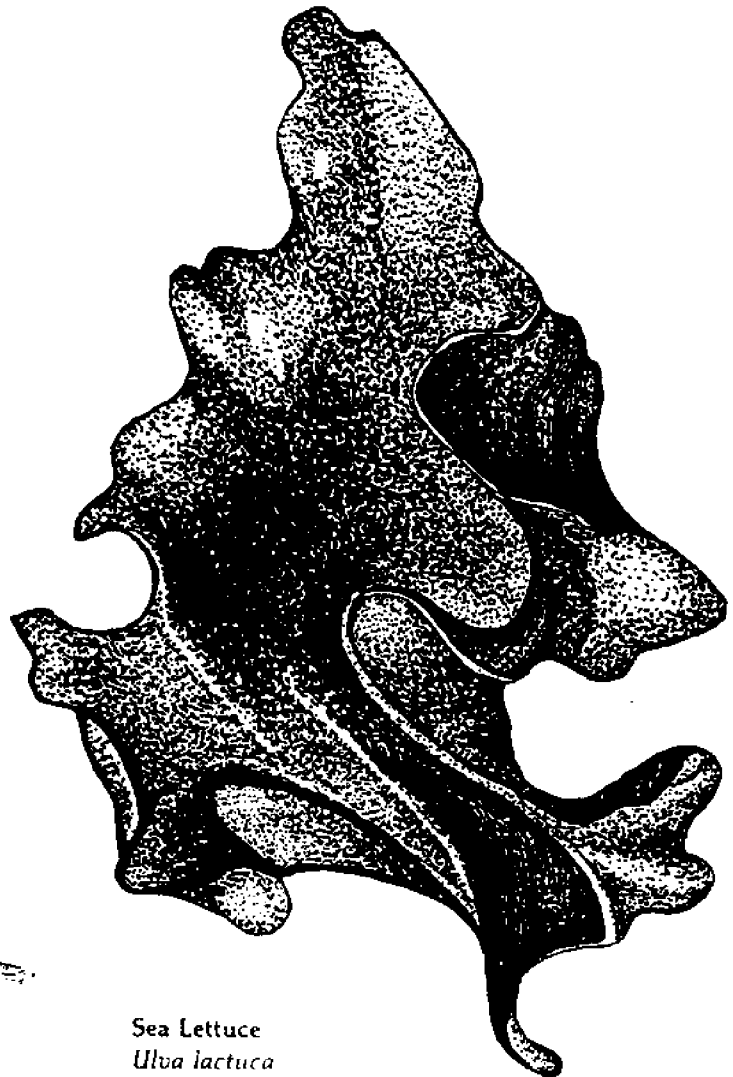

Sea Lettuce
Ulva lactuca
green algae, upper tide pools

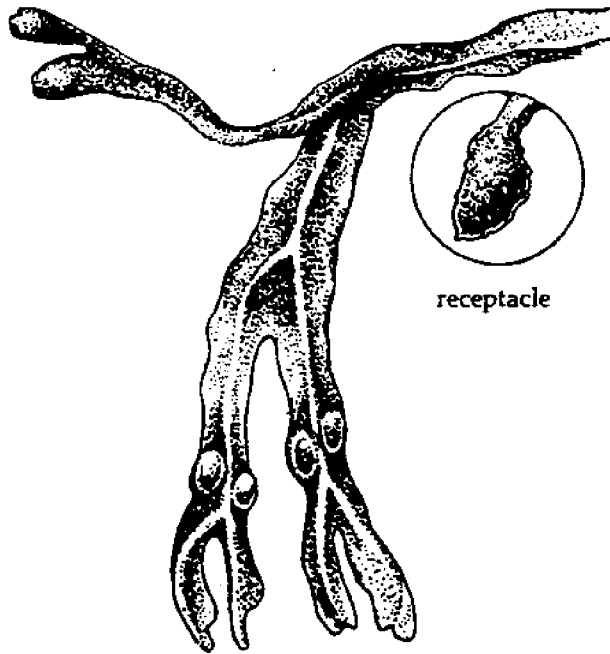
**Bladder Wrack***Fucus vesiculosus*

brown algae, called rockweed, dominant in rockweed zone

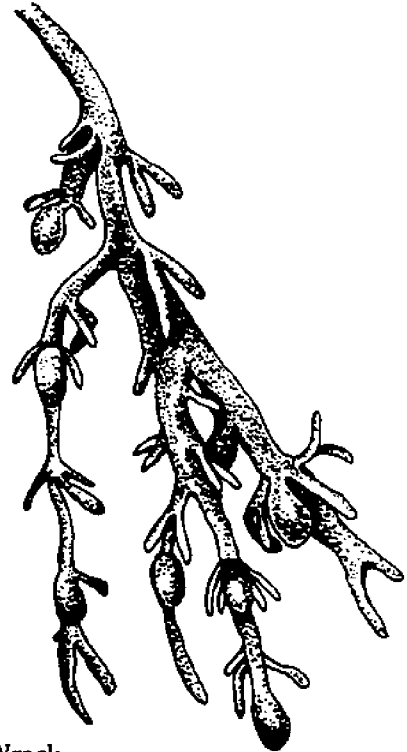
**Knotted Wrack***Ascophyllum nodosum* (to 2 ft.)

brown algae, called rockweed, dominant in rockweed zone

**Eelgrass***Zostera marina*

green algae, below low tide in shallow water growing in sand or mud

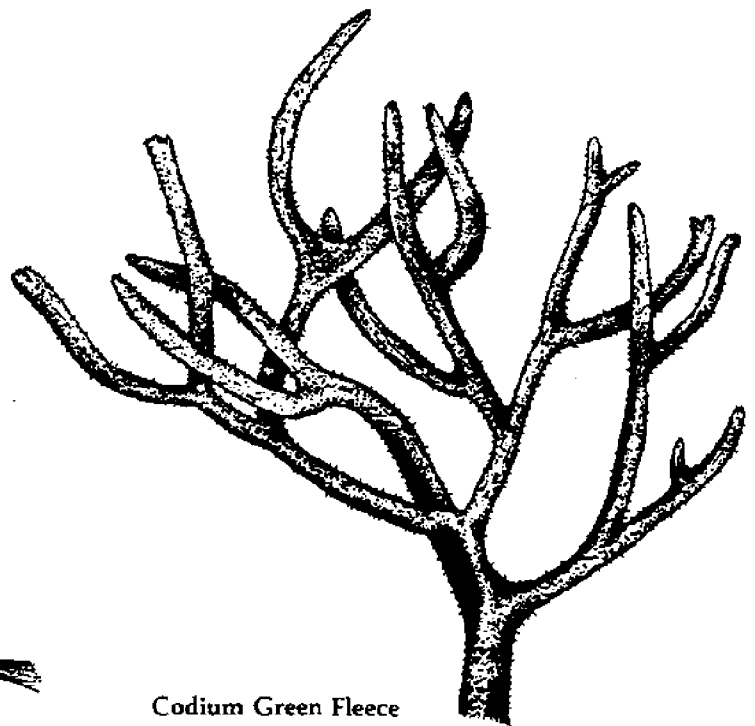
**Codium Green Fleece***Codium fragile*

velvety textured green algae, erect, attached to shells and stones near low tide and in tidal pools



Sea Colander (to 6 ft., sometimes twice that)
Agarum cribrosum
 attached to rocks by holdfasts at or below low tide, brown algae

— Hollow Stemmed Kelp
Laminaria longicuris
 attached to rocks by holdfasts at or below low tide, brown algae

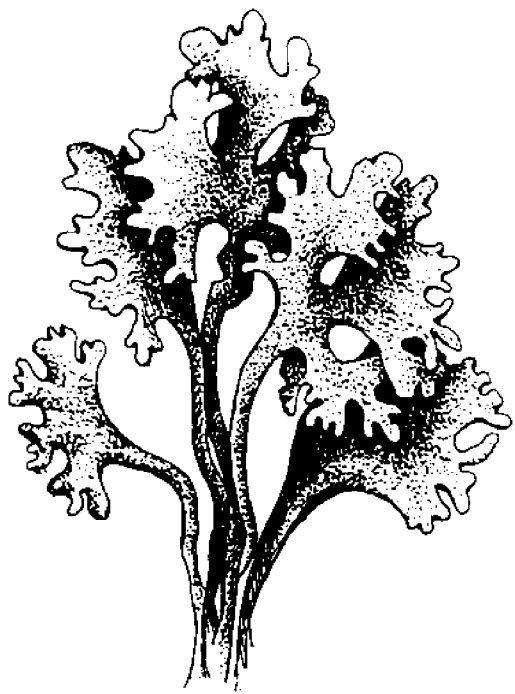

Irish Moss
Chondrus crispus
 red algae, from definite zone between rockweeds and kelp at low tide line



Tufted Red Weed
Gigartina stellata
 red algae, form definite zone between rockweeds and kelp at low tide line (to 3 inches)

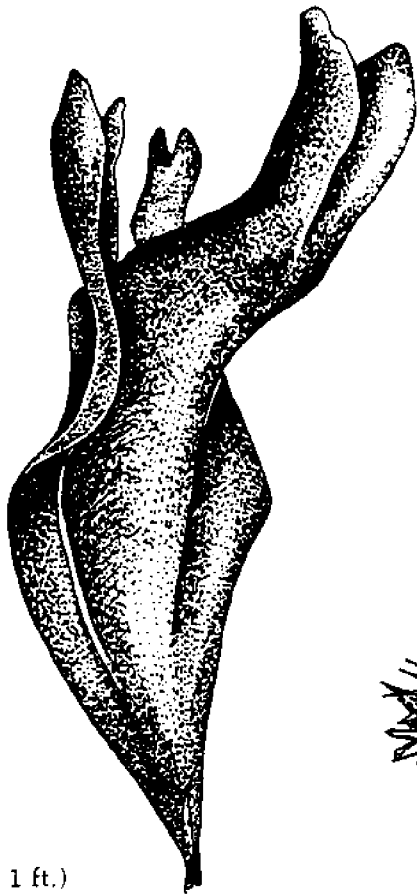

Dulse (to 1 ft.)
Rhodymenia palmata
red algae, Irish moss zone into deep water

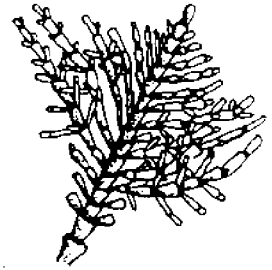

Coral Weed
Corallina officinalis
segmented, fan-shaped tufts from deep turf on rocks and under large algae (to 1½ inches)

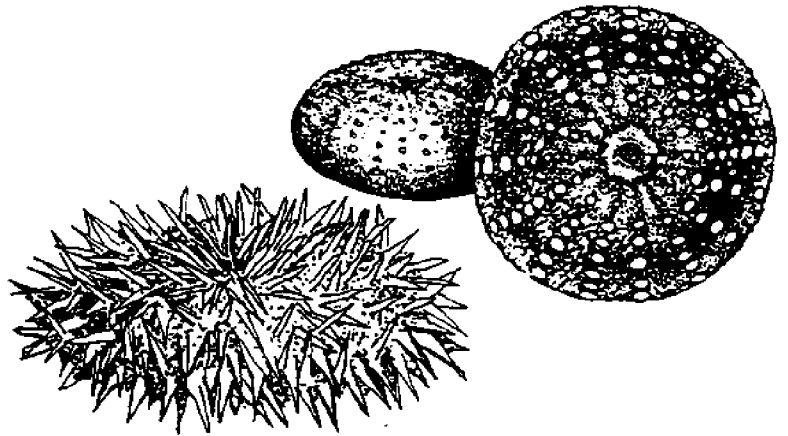

Green Sea Urchin
Strongylocentrotus dröbachiensis
tide pools and deep water (to 3 inch diameter)

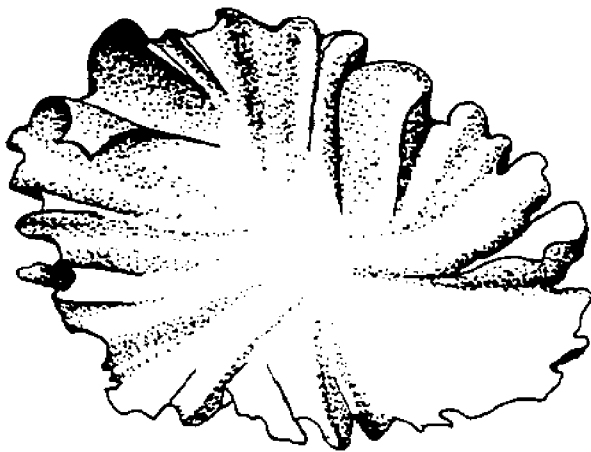

Laver (to 1 ft.)
Porphyra sp.
red algae, paper-thin, nearly transparent, in tidal pools and near low tide line

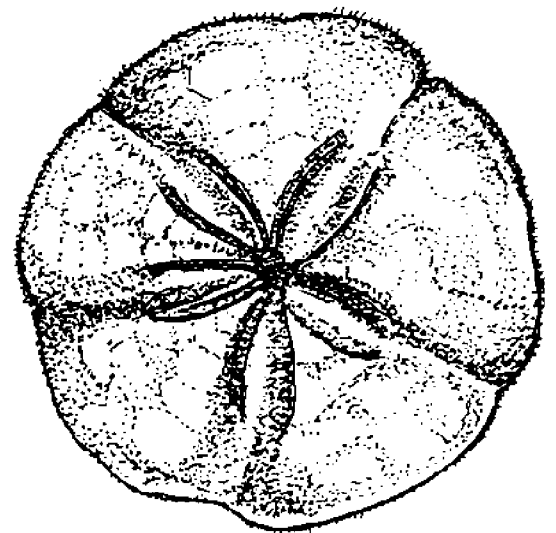

Sand Dollar
Echniarachnius parma
lower intertidal zone and more than one-half mile deep on sandy bottoms (to 3 inch diameter)

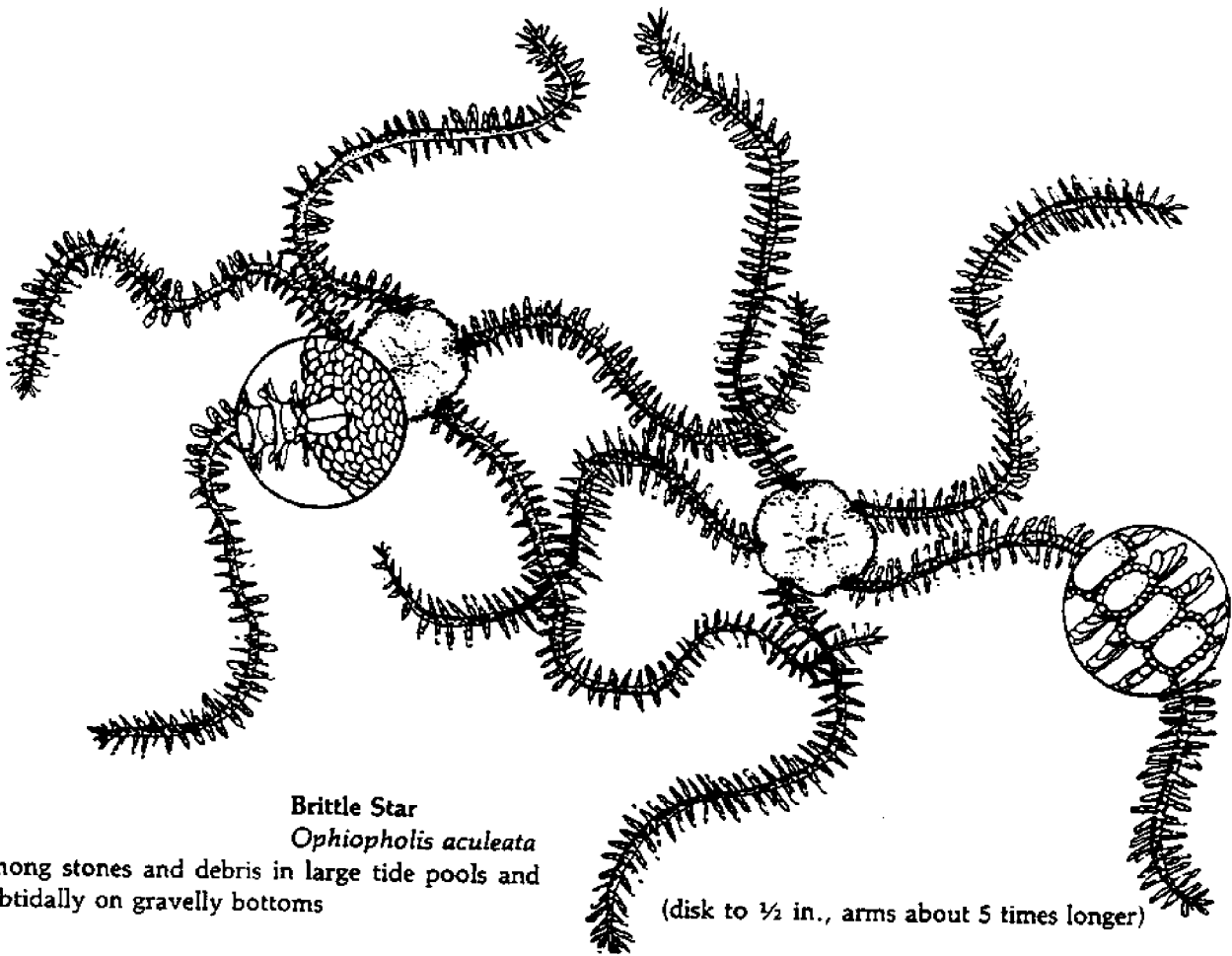

Brittle Star
Ophiopholis aculeata

among stones and debris in large tide pools and subtidally on gravelly bottoms

(disk to ½ in., arms about 5 times longer)

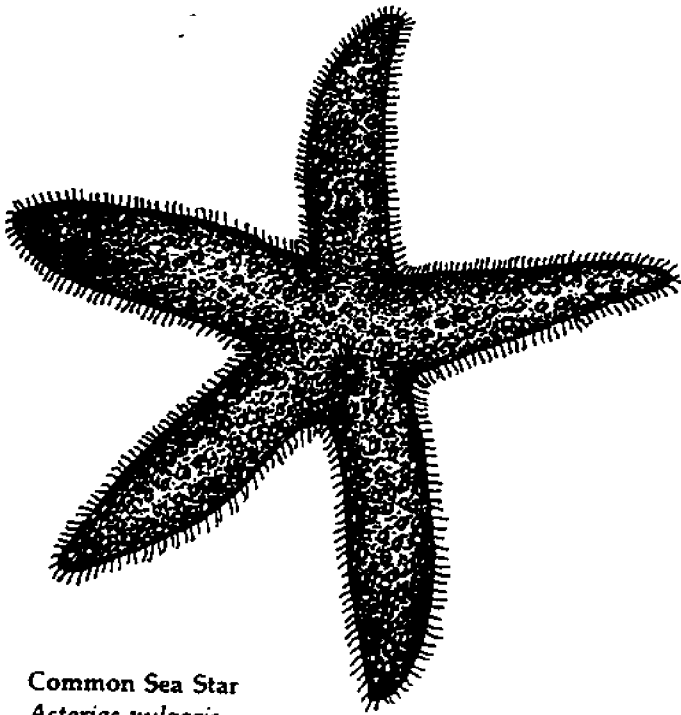

Common Sea Star
Asterias vulgaris
tide pools, rocky or sandy bottoms (to 8 inches)

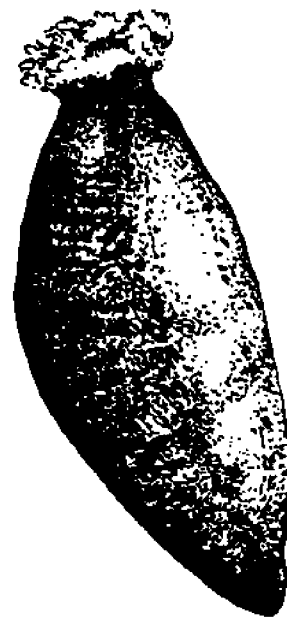

Sea Cucumber
Cucumaria frondosa (to 7 inches)
tide pools, intertidal zone, subtidally down to more than 1,000 feet

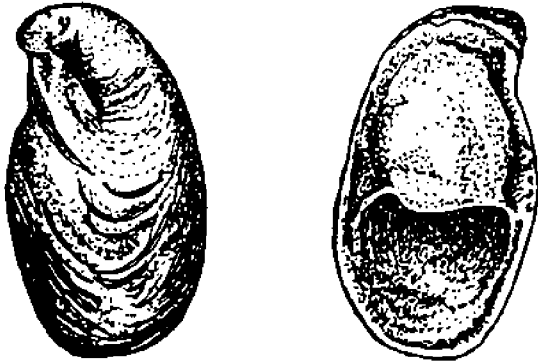

Common Slipper Shell
Crepidula fornicata (to 1½ inches)
 attached to almost any available hard object in
 lower intertidal zone

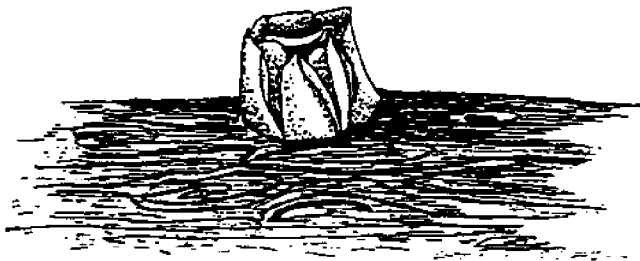

Barnacle
Balanus balanoides (to ½ inch)
 on shells, rocks, rockweeds, and pilings intertidal-
 ly, subtidally into shallow waters



Red Chiton
Ischnochiton ruber
 intertidal zone
 (to 1 inch)

Top

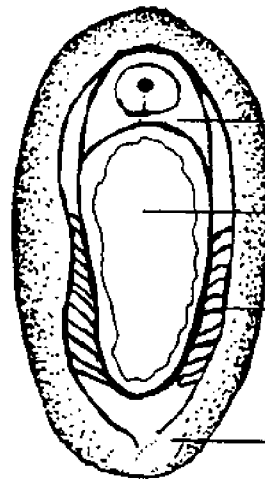

Bottom

head

foot

gills

girdle

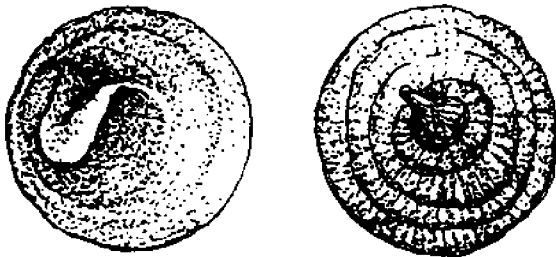

Limpet
Acmaea testudinalis (to 1 inch)
 on rocks in intertidal and subtidal areas

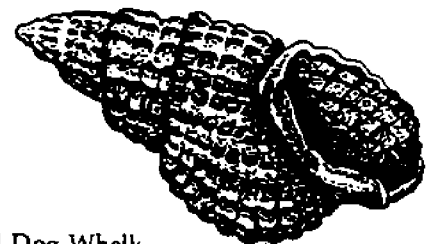

New England Dog Whelk
Nassarius trivittatus (to ¾ inch)
 subtidally in quiet waters on sand or grassy flats

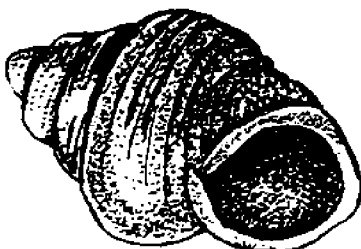

Periwinkle
Littorina littorea (to 1¼ inch)
 intertidally attached to any solid substratum

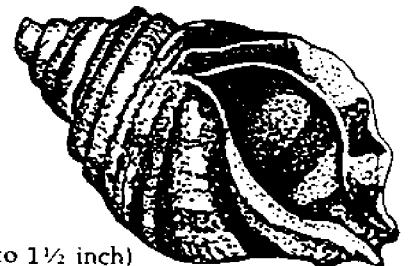

Dog Winkle
Thais lapillus (to 1½ inch)
 intertidal and subtidal zone

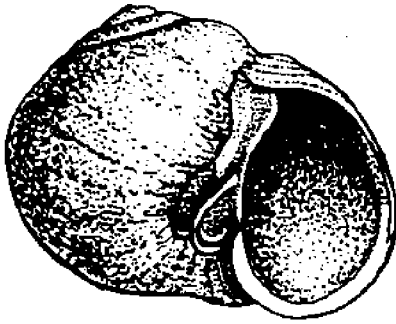

Northern Moon Shell
Lunatia heros (to 4 inches)
 on beaches and subtidally to depths of 1,200 feet

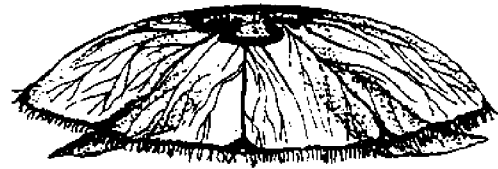

Jelly Fish
Aurelia aurita (to 10 inches)
 free swimming, found washed up on nearly all beaches; color ranges from white to pink and orange



Crumb of Bread Sponge
Halichondria panicea
 (colonies can extend over several feet)
 in colonies encrusting walls or crevices in shaded tide pools from lower intertidal to subtidal zone

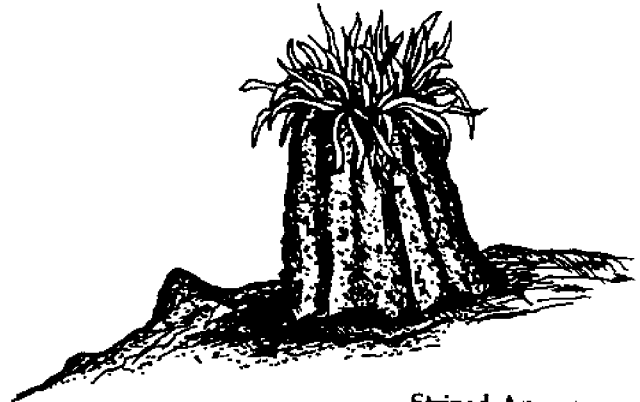

Striped Anemone
 (to 3/4 inch) *Haliplanella luciae*
 on rocks and pilings intertidally and in estuaries and other protected waters; column dark green with lighter colored stripes



Rough Sea Squirt
Styela partita (to 1 1/2 inch)
 often in clumps in lower intertidal zone



Frilled Anemone
Metridium senile
 on pilings, crevices, and pools intertidally; most common anemone; column orange, brown, or mottled; many fine tentacles (to 4 inches tall)

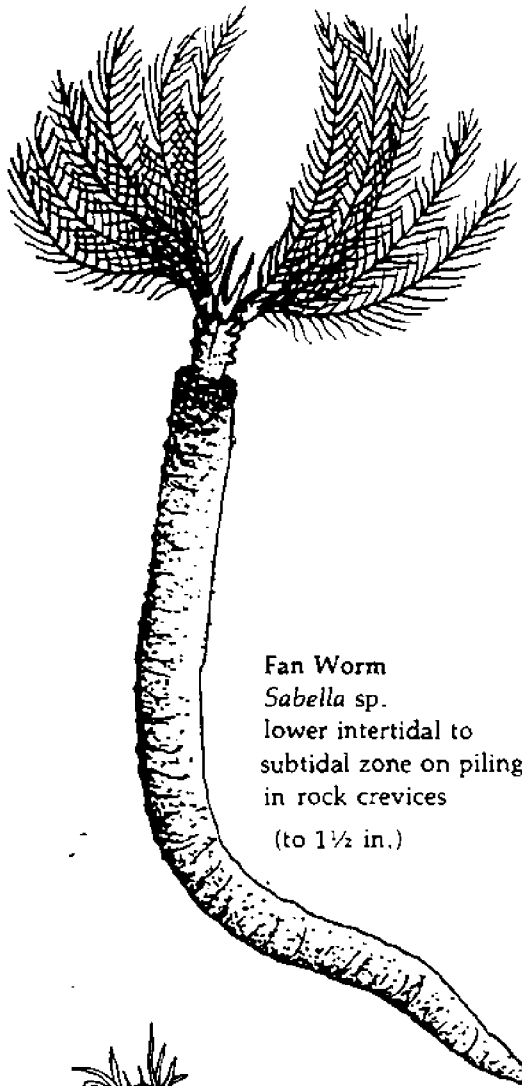

Fan Worm
Sabella sp.
lower intertidal to
subtidal zone on pilings and
in rock crevices
(to 1½ in.)

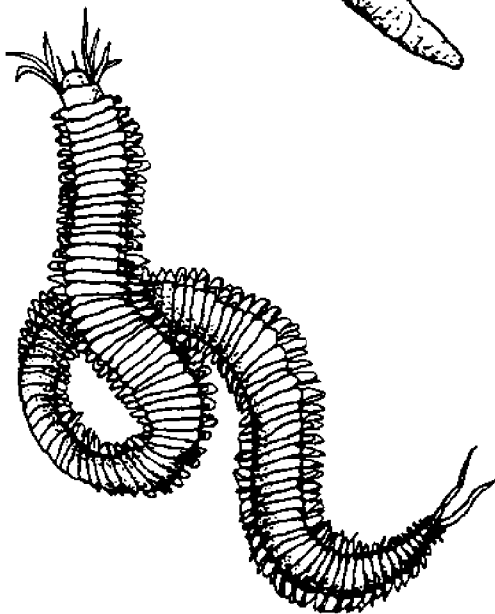

Clam Worm
Nereis sp. (to 8 in.)
upper intertidal to subtidal zone down to 500 feet;
common bait worm; coppery brown or red

Tube Worm
Spirorbis sp.
intertidally on seaweeds or stones;
deposits hard, limy tubes
formed into coils
(to 3 in.)

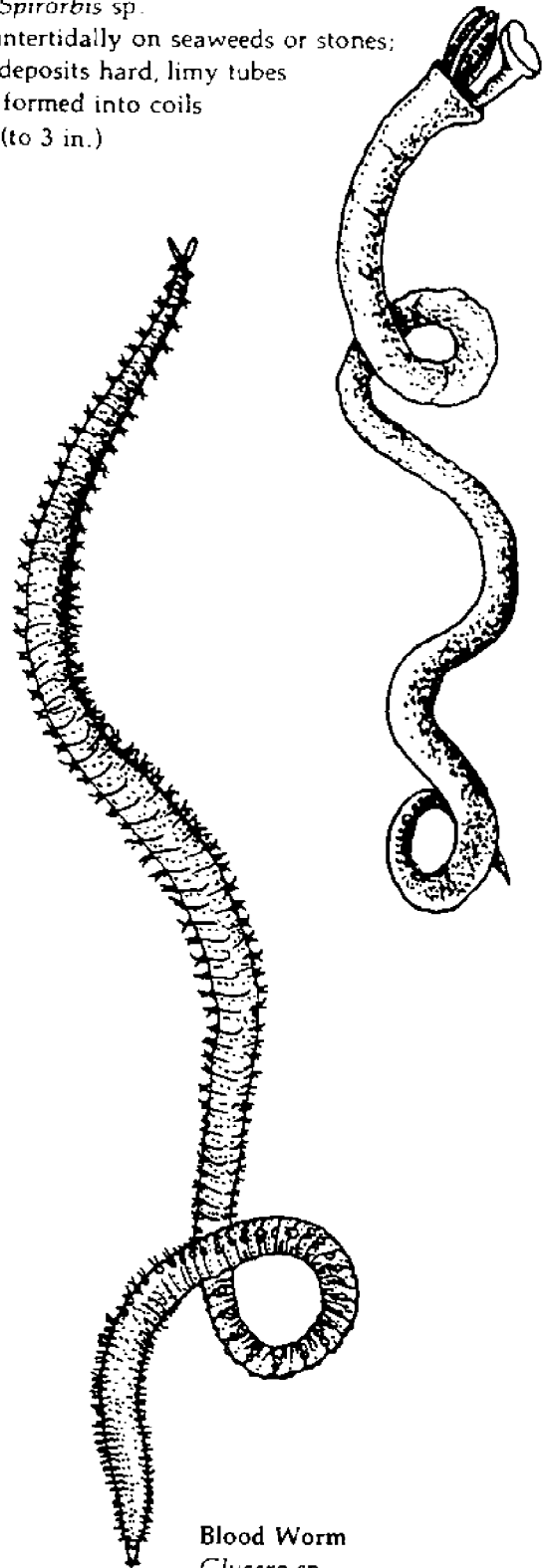

Blood Worm
Glycera sp.

intertidally in mud flats and among organic debris
mixed with sand and subtidally down to 1,000
feet; common bait worm; palely translucent body
allows internal fluids to show through (to 15 in.)

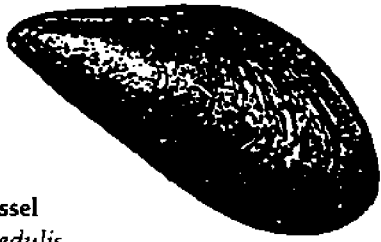

Blue Mussel
Mytilus edulis
 intertidal to subtidal zones attached to rocks and pilings (to 4 inches)

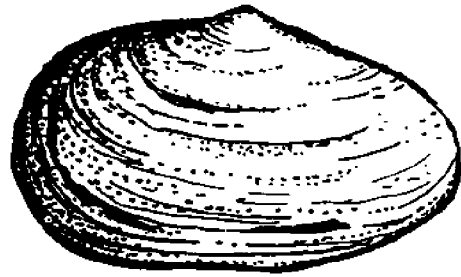

Soft Shell Clam
Mya arenaria (to 4 inches)
 intertidal to subtidal zones in sandy or muddy areas

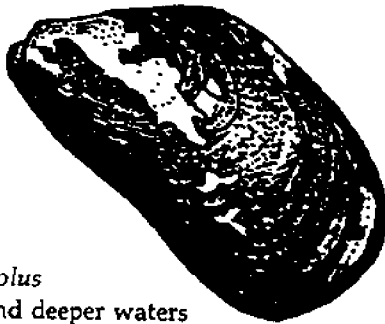

Horse Mussel
Modiolus modiolus
 subtidal zone and deeper waters (to 6 inches)

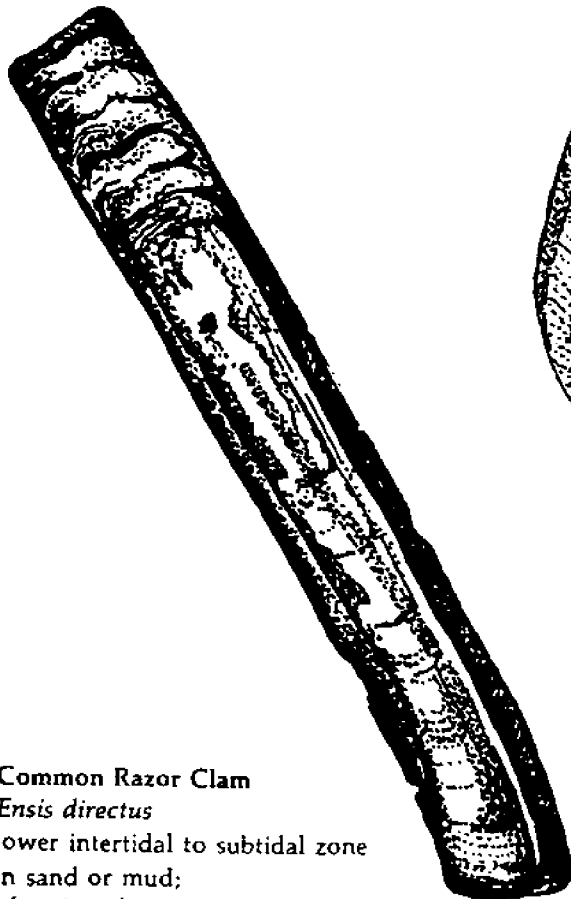

Common Razor Clam
Ensis directus
 lower intertidal to subtidal zone in sand or mud; often in colonies (to 10 inches)

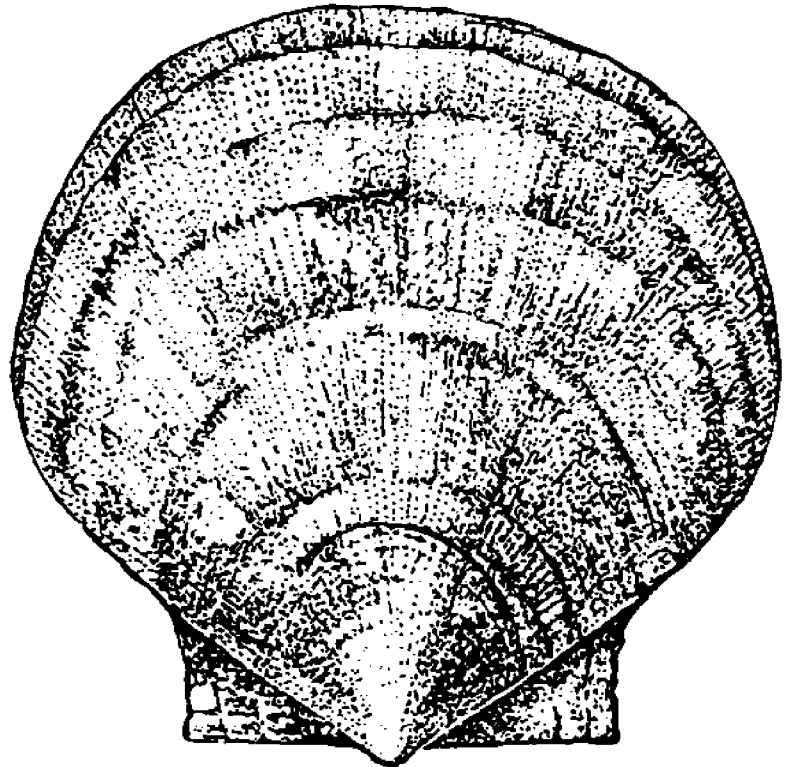

Deep Sea Scallop
Placopecten magellanicus
 low tide line down to 50 feet on a variety of bottoms; often a beach shell (to 8 in.)

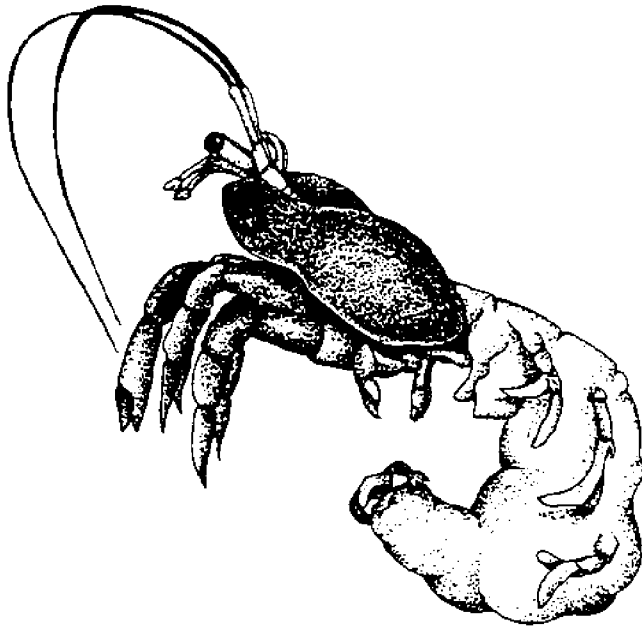

Hermit Crab

Pagurus longicarpus (to approx. ¼ in. long)
 tide pools and intertidal rocks, lives in discarded
 shells of other animals and continues to seek larger
 ones as it grows

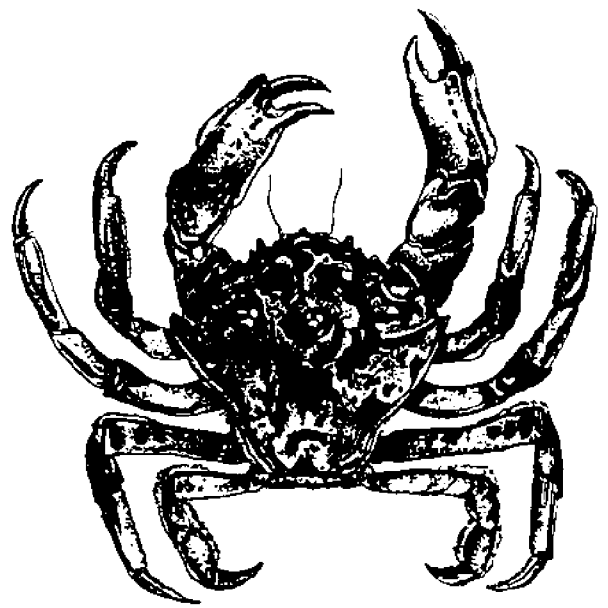

Green Crab (to 3 inches)

Carcinus maenas
 under rocks in intertidal zone



Rock Crab (to 5¼ inches)

Cancer irroratus
 under rocks in intertidal zone

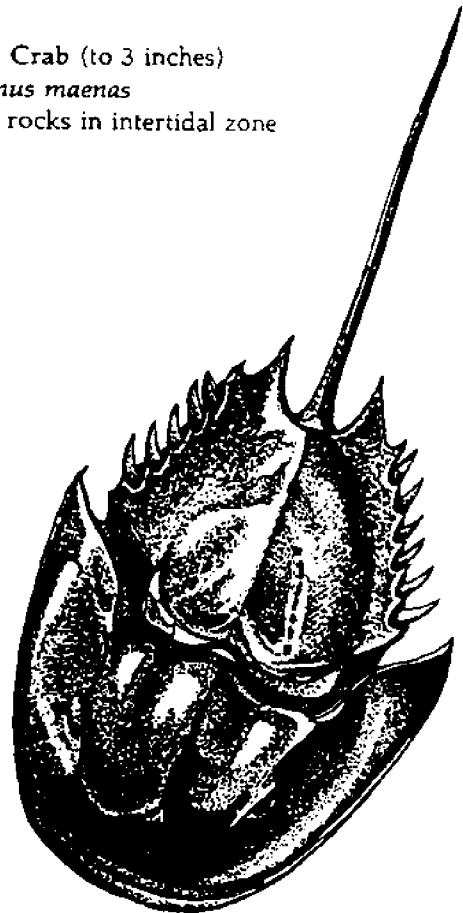

Atlantic Horseshoe Crab (to 2 ft. including tail)

Limulus polyphemus
 along intertidal beaches and in subtidal waters

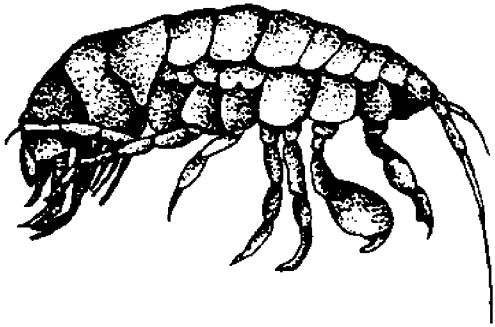

Beach or Sand Flea (to 1½ inch)
Orchestia sp.
under dead seaweed and other debris at or above high tide mark, leap erratically when disturbed, olive to reddish brown



Sand Shrimp (to 2¾ in.)
Crangon septemspinosa
lower intertidal zone to subtidal zone down to 300 feet or more; varies from almost colorless to mottled brownish or black



American Lobster (to 3 ft.)
Homarus americanus
subtidal waters to edge of continental shelf

APPENDIX F

Cleaning & Dressing Fish

(Reprinted with permission from Northern New England Marine Education Project.)

Cleaning and Dressing Fish

Materials:

Scaling knife (optional), filleting knife, cutting board or surface, sink for cleaning, garbage bags for "remains," towels and of course, safety.

1

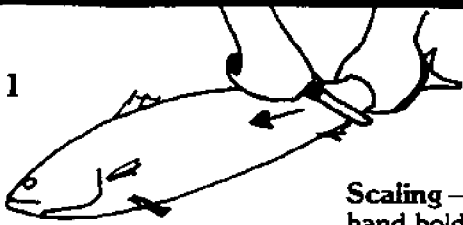

Dressing a whole fish for baking

Scaling — Wash the fish. Place the fish on a cutting board and with one hand hold the fish firmly by the head. Holding a knife almost vertical, scrape off the scales, starting at the tail and moving toward the head (fig. 1).

2



Cleaning — With a sharp knife cut the entire length of the belly from the vent to the head. Remove the intestines. Next, cut around the pelvic fins and remove them (fig. 2).

3

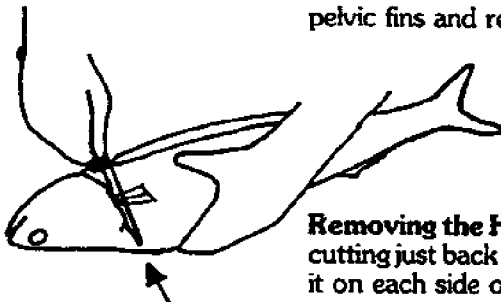

Removing the Head and Tail — Remove the head and pectoral fin by cutting just back of the collarbone. If the backbone is large, cut down to it on each side of the fish (fig. 3).

4

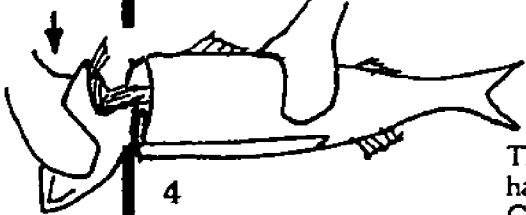

Then place the fish on the edge of the cutting board so that the head hangs over and snap the backbone by bending the head down (fig. 4). Cut and discard any remaining flesh that holds the head to the body. Cut off the tail.

5

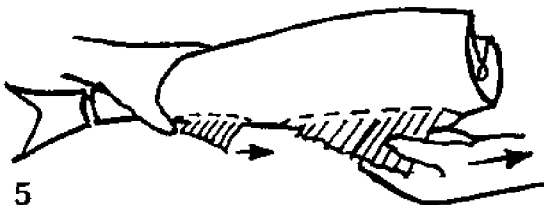

Removing the Fins — Next remove the dorsal fin, the large fin at the back of the fish, by cutting along each side of the fin (fig. 5). Then give a quick pull forward toward the head and remove the fin with the back bones attached (fig. 5). Remove the ventral fin in the same way. Never trim the fins off with shears or a knife because the root bones at the base of the fins will be left in the fish. Wash the fish thoroughly in cold running water. The fish is now dressed or pan-dressed depending on its size.

APPENDIX G

Shellfish Species Characteristics

(Reprinted with permission from Maine Department of Marine Resources.)

Soft-shell Clam (*Mya arenaria*)



Classification: Phylum: Mollusca; Class: Bivalvia

Description: Soft-shell clams are elongated, thin-shelled bivalves. Their shells vary in color from white to dark grey according to their habitat. They have a long, extendable siphon or "neck."

Habitat: These clams are found intertidally and subtidally from subarctic areas to the Carolinas.

Movement: Soft-shell clams can burrow into the mud up to two and half times their shell length by using their muscular foot. This hatchet-shaped foot works best when the clam is small.

Respiration: These clams have two pairs of gills in their mantle cavity. These gills exchange gases and assist in the ingestion process.

Ingestion: Their "neck" is composed of two siphon tubes. The incurrent siphon tube allows water containing microscopic plankton to enter their mantle cavity. The gills trap and transport food toward the mouth using mucus and cilia. The labial palps sort and direct food to the mouth.

Growth: A fleshy membrane called the "mantle" secretes the limy shell. Thickened ridges on the shells indicate yearly growth. Thinner lines are interpreted as stress rings. Soft-shell clams can grow four to five inches in length.

Excretion: Digestive wastes exit their body by way of the anus into their excurrent siphon tube. Liquid wastes are removed by the excretory gland and eliminated through a pore into the mantle cavity and out the siphon.

Nervous System: The nervous system consists of three nerve centers connected by two pair of nerves. The margin of their mantle is the principal location of the clam's sensory cells.

Circulation: Their chambered heart pumps blood through a system of blood vessels that empty into sinuses surrounding the body organs.

Reproduction: The gonad can be found in the visceral mass. Reproduction takes place when male and female clams release sperm and eggs into the water. Fertilized eggs develop into free-swimming larvae before settling to the bottom.

Common Names: "steamer," "long-neck," "squirt clam," "belly clam," "nannynose" and "gaper"

Predators: They are preyed upon by green crabs, sea stars, birds, fish, whelks, lobsters and man.

Commercial Value: In 1992, 2,265,592 bushels of clams were harvested at a value of \$7,862,425.

Other Gulf of Maine Species: Razor Clam (*Ensis directus*), Quahog (*Mercenaria mercenaria*), Ocean quahog (*Arctica islandica*) and Surf Clam (*Spisula solidissima*)

Soft-shell Clam

External Anatomy

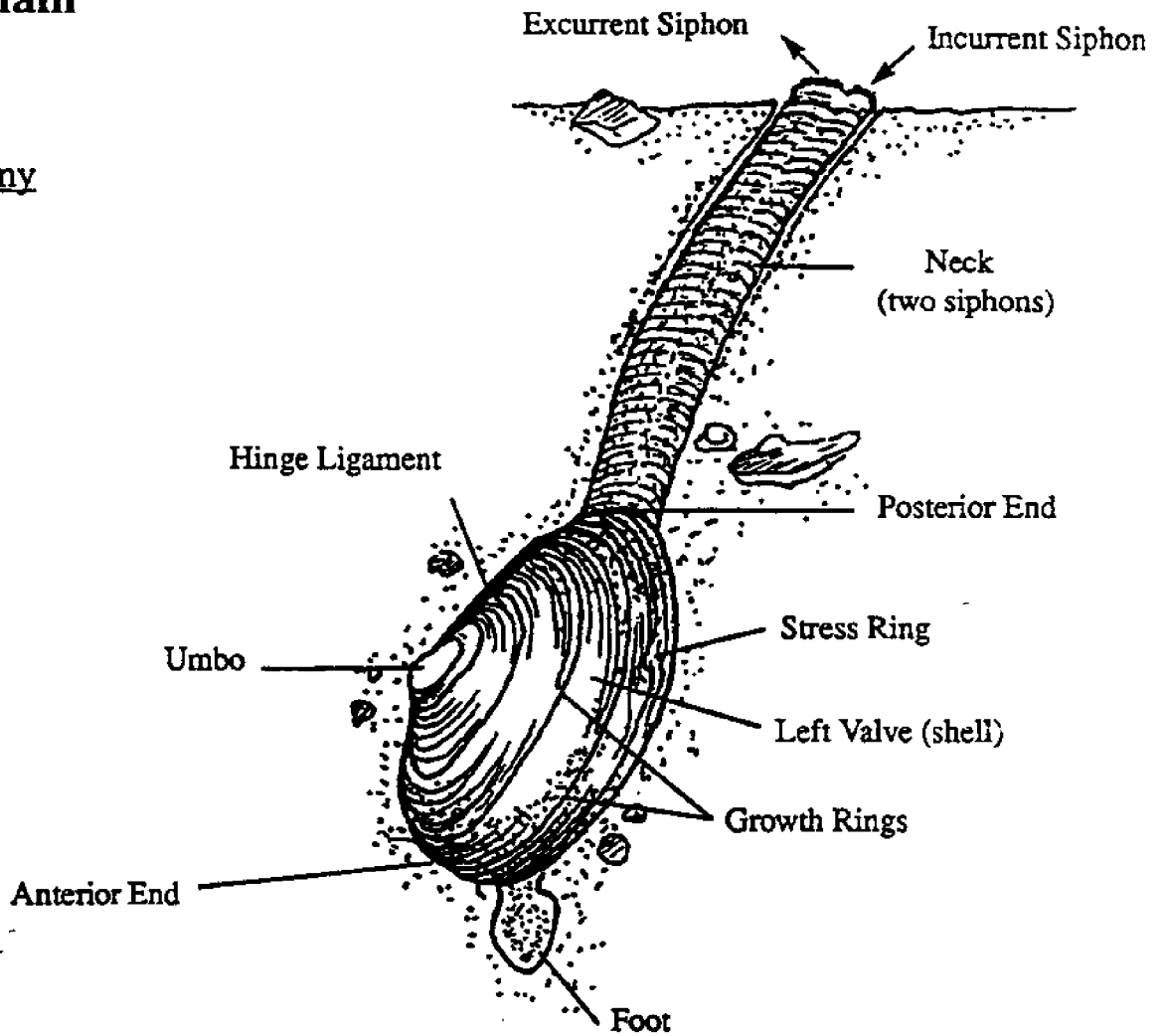

Internal Anatomy

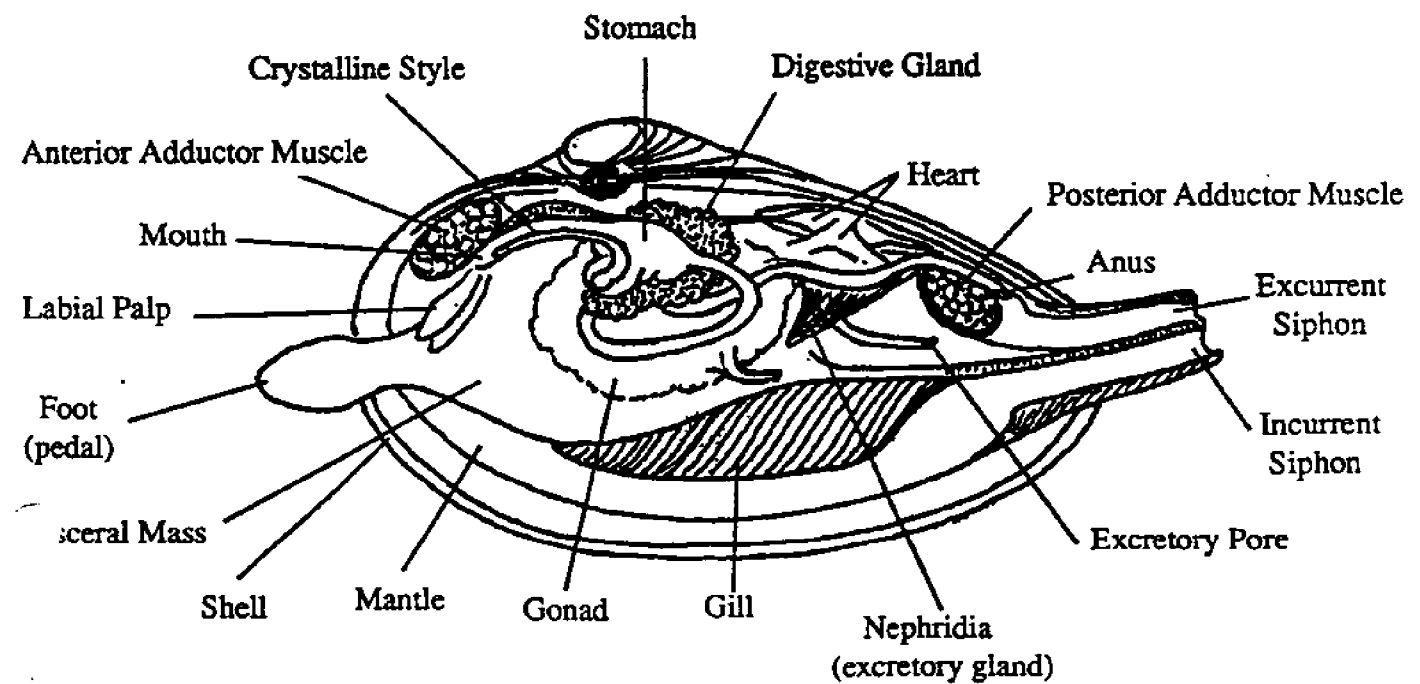

Gulf of Maine Species of Clams



Soft-shelled Clam
(*Mya arenaria*)

- white, elongated, thin shell
- often called "steamers"
- found intertidally in mud flats
- harvested commercially



Hard-shelled Clam
(*Mercenaria mercenaria*)

- thick, white shell with a purple edge on the inside
- commonly called "Quahog" in New England
- found intertidally and subtidally in sand or muddy sand
- harvested commercially
- Indian's used this shell to make wampum.

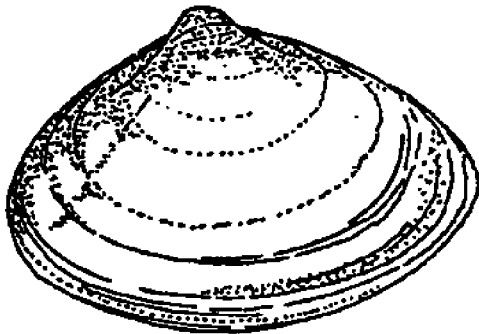

Surf Clam
(*Spisula solidissima*)

- large clam that grows to eight inches
- white shell is somewhat triangular
- sometimes called a "hen" clam
- found in the very low intertidal zone or subtidally along beaches
- meat is canned or used in clam cakes

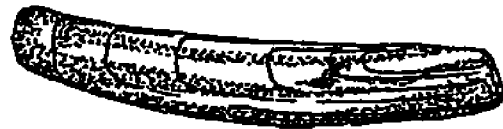

Razor Clam
(*Ensis directus*)

- fragile shell measuring up to ten inches in length
- sometimes called a "jackknife" clam
- found in the low intertidal zone and subtidally in sandy-mud bottoms
- burrow quickly and deeply into bottom substrate



Baltic Macoma Clam
(*Macoma balthica*)

- small, oval clam measuring up to 1 1/2 inches in length
- mud dwellers in shallow quiet bays

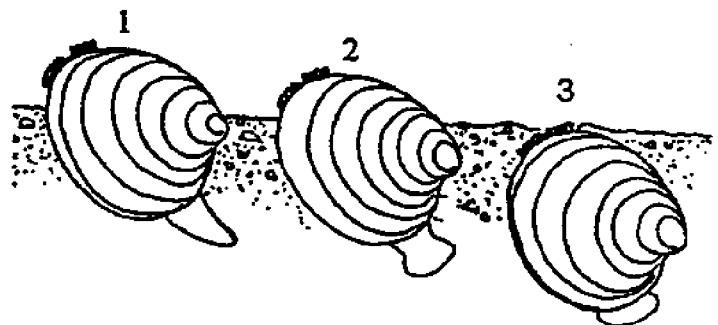

Clam's Method of Burrowing

The clam pushes its muscular foot into the sand or mud. Blood entering the foot causes it to swell and form a hatchet-shaped anchor. The foot muscles contract pulling the clam down into the substrate.

Clam Activities

1. Observations of live clams

- a) Obtain soft-shell clams ("steamers") from your local fish market or supermarket. (keep refrigerated)
- b) Place the clams in a container of seawater. Observe and describe their size, color, shape, shell etc.
- c) Pick up the clams and touch their black "neck" with your finger. What did they do?

2. Comparing different species of clams

- a) Pass out different kinds of clam shells such as: soft-shell, quahog, razor, hen and mahogany clams.
- b) Have the students trace around each shell on a piece of paper.
- c) Use a field guide to identify the different species of clams.
- d) Write the name and characteristics about each clam within its traced outline.

3. Explorations

- a) How do clams move?
 - Place sand in the bottom of a container and add seawater.
 - Observe a small clam as it attempts to burrow itself into the sand. How does it perform this task?
- b) How do clams eat?
 - Place a clam, siphon end up, in a container of sand. Add seawater to the container.
 - Add a drop of concentrated red food coloring near the siphon. Observe the movement of the dye.
 - Where was the water drawn into the clam? Where was it expelled from the clam?
- c) Raising Soft-shell clams in the classroom
 - Juvenile clams are available from Beals Island Regional Shellfish Hatchery, Beals, ME 04611. (207) 497-5769. They will provide you with instructions on how to set up the proper apparatus for rearing them in the classroom.
 - Design and conduct your own growth studies on clams.

4. Reseed an area of a mud flat

- a) Submit your plan and site to the Department of Marine Resources for approval.
- b) Obtain juvenile clams from the Beals Island Regional Shellfish Hatchery.
- c) As the tide is coming in, gently toss the clams on the surface and they will burrow in to the correct depth. Be aware that sea gulls will feast on these clams if they are exposed for a long period of time.
- d) Use fixed reference points to identify your reseeded area, if you wish to return for further studies.

5. Art Activities

- a) Make a mobile with clam shells.
- b) Rubbings of clam shells will identify growth rings.
- c) Glue ocean treasures inside of a clam shell for use as a Christmas ornament.

6. Research

- a) Management plans practiced by the State of Maine and those of local municipalities.
- b) Paralytic Shellfish Poisoning (PSP) and how it is monitored in the State of Maine.
- c) Depuration plants which purify clams taken from polluted mudflats.
- d) What has been the commercial harvest & value of clams in Maine over the past 50 years?

Blue Mussel (*Mytilus edulis*)



Classification: Phylum: Mollusca; Class: Bivalvia

Description: Blue mussels are bivalves that have two, smooth, tear-shaped, bluish-black shells. They attach themselves to almost any substrate by means of byssal fibers or threads.

Habitat: Mussels live in dense colonies or beds and are found intertidally and subtidally. Their range extends from subarctic areas to South Carolina.

Movement: Mussels are sedentary by nature. If they should become disturbed or if they develop a need to resettle, they can dissolve their byssal threads. These bivalves will use their muscular foot to relocate.

Respiration: The exchange of oxygen and carbon dioxide occurs through two pairs of gills located in the lateral mantle cavities.

Ingestion: Mussels are known to be very efficient filter feeders processing two liters of water per hour. Water containing plankton enters through their incurrent siphon and is directed toward their gills. There, food particles are then trapped and transported by cilia to the labial palps which surround their mouth.

Growth: The mantle produces the annual rings on the shell which represent yearly growth. Mussels grow to an average shell length of two to four inches.

Excretion: Body wastes and processed water are expelled through their excurrent siphon.

Nervous System: The nervous system consists of three nerve centers connected by two pairs of nerves. The margin of the mantle is the principal location of the mussels sensory cells.

Circulation: Nutrients and oxygen absorbed into the blood are pumped by a heart through a system of vessels. These vessels transport the blood to the various sinuses throughout the body.

Reproduction: Mussels either expel sperm or eggs into the water. These gametes are released in large quantities to ensure fertilization. Development involves a planktonic stage before they settle onto the ocean substrate.

Common Names: "edible mussel," "moules"

Predators: They are preyed upon by birds, fish, crabs, whelks, lobsters, sea stars and man.

Commercial Value: The 1992 reported landings in Maine were 3,086,500 pounds having a commercial value of \$1,020,859.00. 10-15% were grown aquaculturally and the rest harvested from native populations.

Other Gulf of Maine Species: Northern Horse Mussel (*Modiolus modiolus*), Atlantic Ribbed Mussel (*Geukensia demissa*)

Blue Mussel

External Anatomy

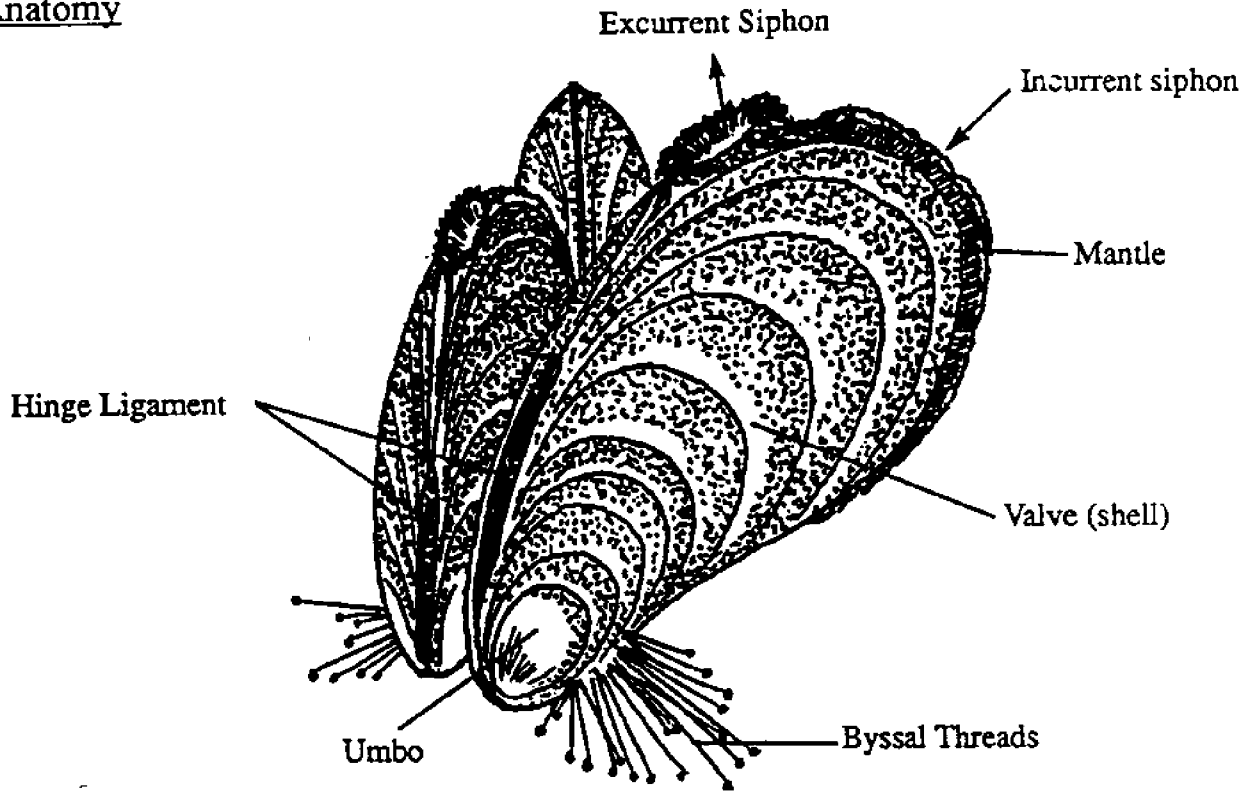

Internal Anatomy

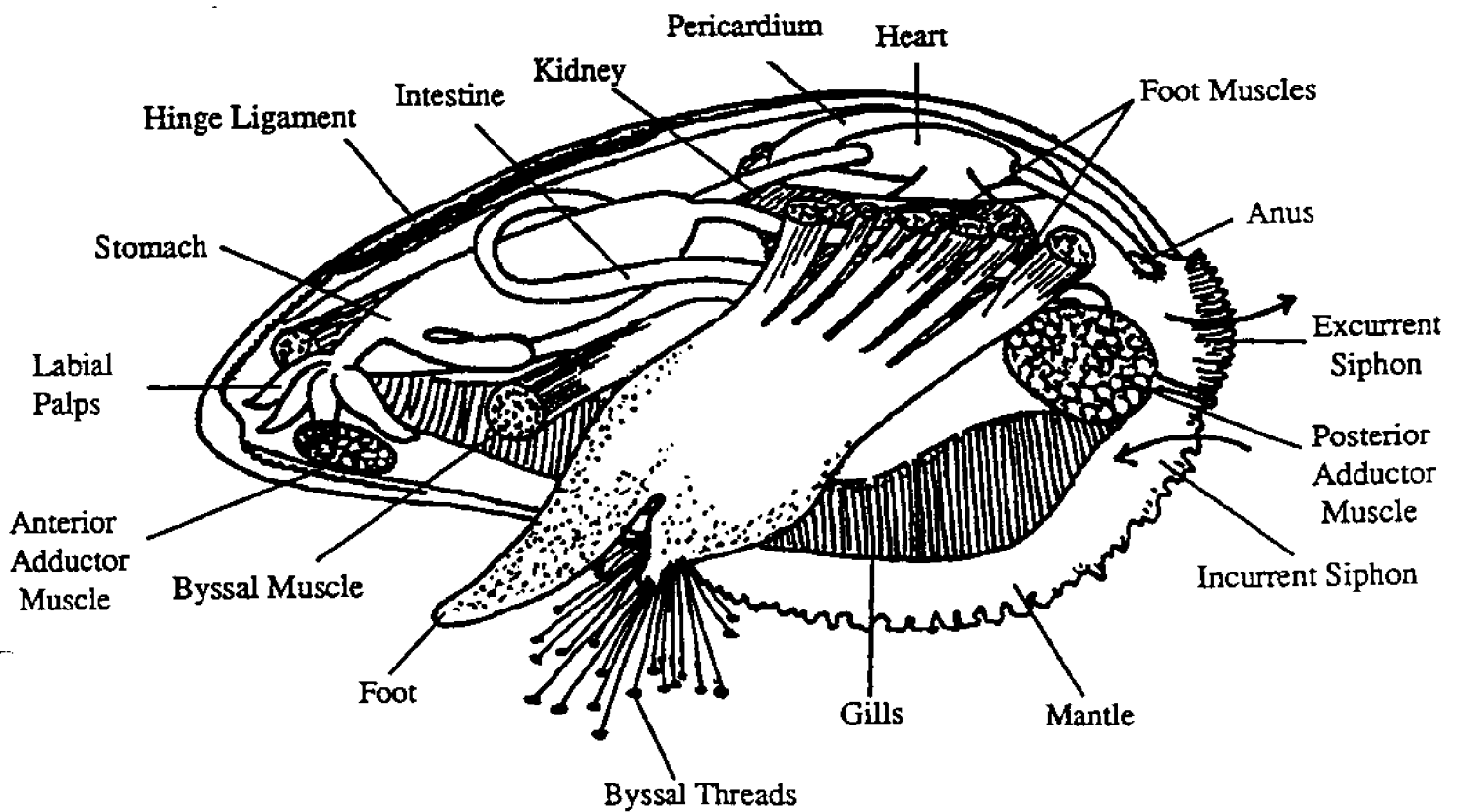

Gulf of Maine Species of Mussels

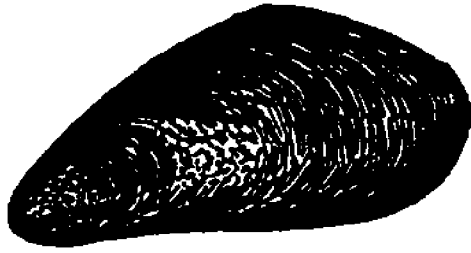

Blue Mussel
(*Mytilus edulis*)

- violet-blue shell with a bluish-black covering
- grows up to four inches in length
- umbo at the end of the shell
- often called the "common edible mussel"
- flesh tends to be cream colored
- competes with barnacles and seaweeds for intertidal space on the rocks
- raised by several aquaculturists in Maine

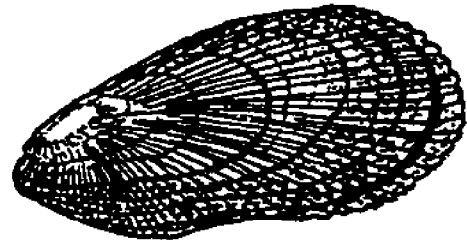

Ribbed Mussel
(*Modiolus demissus*)

- brittle, greenish or yellowish brown shell
- shell has numerous, rough, radial ribs
- grows up to four inches in length
- meat is less palatable as it is tough and bitter
- found living half-buried in the muddy banks of the salt marsh

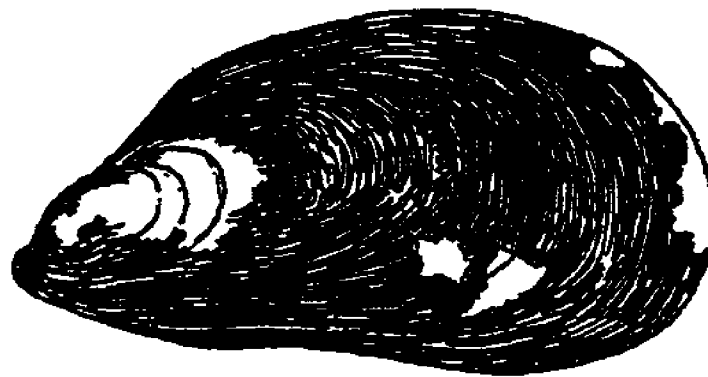

Horse Mussel
(*Modiolus modiolus*)

- thick, brown shell four to six inches long
- a ragged fringe of brown outgrowths on the shell
- umbo at one side of the end of the shell
- edible but orange flesh is tough
- usually found subtidally along the rocky shore or washed ashore in the grip of kelp holdfasts

Mussel Activities

1. Observations of live mussels

- a) Place a live mussel in a clear container of seawater. Be sure that the water covers the mussel.
- b) Observe and describe its size, color, shape and protective adaptations.
- c) Does it have any threads coming off from it? What might it use these threads for?

2. Comparison of species

- a) Obtain the shells of the three different types of mussels found in Maine; blue mussel, horse mussel and ribbed mussel.
- b) Compare the color, size and shape of each. Use a ruler to measure the length of each.
- c) Research the preferred habitat of each species.

3. Explorations

- a) How does temperature effect the heart rate of a mussel?
 - Gently pry open the shells with a knife. Insert the knife between the mantle and the shell and sever the two adductor mussels. Remove one valve and place the mussel back into 15°C seawater.
 - Use a dissecting microscope to observe the heart and determine its rate of contraction every two minutes.
 - Repeat the procedure with the temperature of the seawater being 10°C and 20°C.
- b) Observing the microscopic cilia on the gills.
 - Using a pair of scissors, remove a small piece from the edge of a gill and mount it on a slide with a drop of seawater.
 - Observe it under a compound microscope and draw the cells of the gill edge. Describe the function of these cells.

4. Mussel mobile

- a) Obtain whole mussel shells that are still attached at the hinge. These shells will be transformed into fish with the hinge end becoming the nose of the fish.
- b) Cut out a dorsal fin, tail fin and pectoral fins from colored construction paper or felt cloth.
- c) Glue these fins into their correct places as you glue the edges of the mussel shell together. Glue a piece of string between the shells as a way to suspend the fish. Wrap it with a rubber band while the glue dries.
- d) Glue eyes in their appropriate places.
- e) Attach the fish to a piece of wood or a coat hanger to create the mobile.

5. Christmas ornament

- a) Using a low temperature glue gun, attach a colorful ribbon to the back of a mussel shell.
- b) Glue a Christmas scene into the shell or a variety of ocean treasures.
- c) Dip the shell into a can of varnish or spray it with polyurethane.

6. Mussel feast

- a) Buy or collect about 2 pounds of blue mussels. Be sure to check for "red tide" if you are collecting.
- b) Combine 1 cup of white wine (non-alcoholic if in school), 2 cups of water, 2 tablespoons of butter, 1 tablespoon of parsley and 1/2 teaspoon of garlic powder. Bring to a boil and cook mussels for 5 minutes. Shake and then steam for another 5 minutes until the shells are open.
- c) Chew carefully because there may be some pearls present in the mussels.

American Oyster (*Crassostrea virginica*)



Classification: Phylum: Mollusca; Class: Bivalvia

Description: Oysters are mollusks that possess two asymmetrical shells. These elongated valves are light colored and have a rough surface.

Habitat: Oysters thrive best in estuarine conditions from the Gulf of St. Lawrence to the Gulf of Mexico. They are usually found below the mean tide level on a bottom type that is firm and non-shifting. Oysters often live in colonies commonly referred to as "beds."

Movement: American Oysters permanently attach themselves to the bottom substrate by use of a cement which they produce after completing their planktonic stage.

Respiration: Oysters have two pairs of gills in their mantle cavity.

Ingestion: Oysters are filter feeders that utilize their gills to trap microscopic food particles. Cilia, on the surface of the gills, transport these particles to the labial palps. These structures sort the food and direct it into the mouth.

Growth: Their two asymmetrical shells are produced by the mantle. Oysters can reach a shell length of ten inches. Pearls may form within oysters if an irritant, like a grain of sand, gets lodged in their mantle.

Excretion: Oysters excrete their wastes into a common canal created by the joining of the mantles and gills.

Nervous System: Sensory tentacles, that detect touch and chemicals, are located along the edge of their mantle. These tentacles are connected by nerve fibers to ganglia.

Circulation: A chambered heart pumps blood through simple branching vessels to sinuses which surround the body's organs.

Reproduction: Oysters reproduce by external fertilization when both sexes release their sperm and eggs into the water. Following several planktonic stages, the young or "spat" must settle onto the correct substrate. American Oysters possess the ability to vary their sex.

Common Names: "eastern oyster," "Atlantic oyster"

Predators: Sea stars, carnivorous snails, boring sponge, crabs and man prey upon oysters.

Commercial Value: Landings for 1992 were 37,017 pounds valued at \$143,056.00. Most American Oysters harvested in Maine are cultivated.

Other Gulf of Maine Species: European Oyster (*Ostrea edulis*)

Oyster

External View of Shell

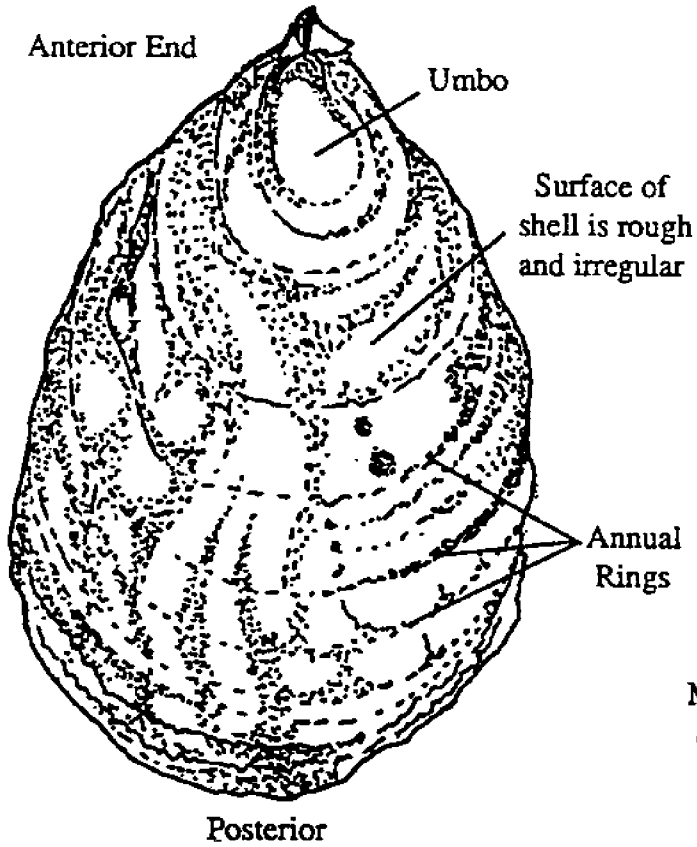

Internal View of Shell

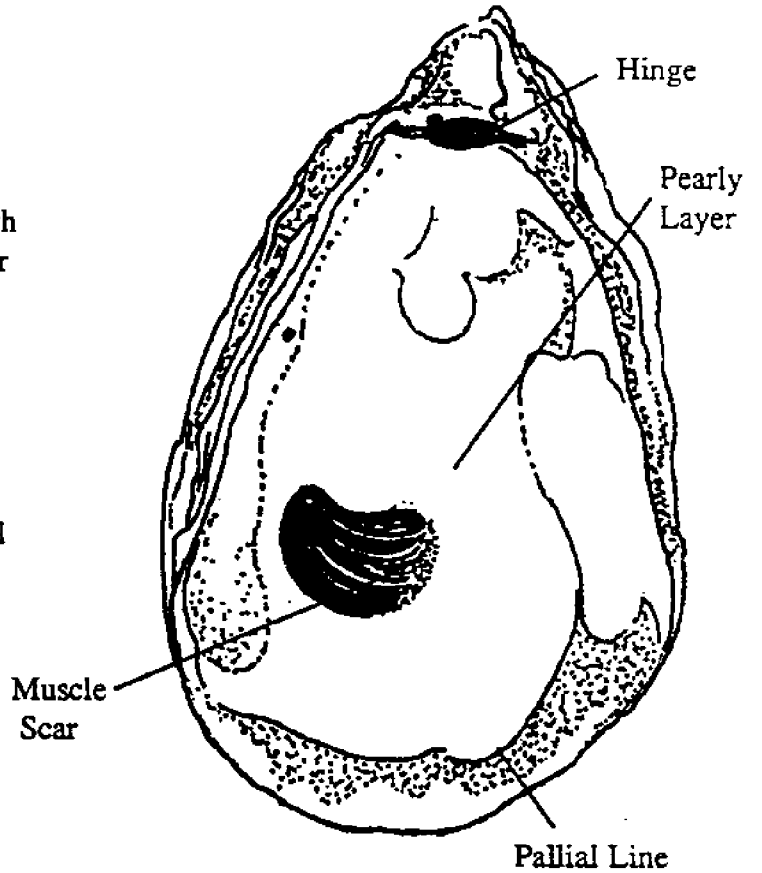

Internal Anatomy

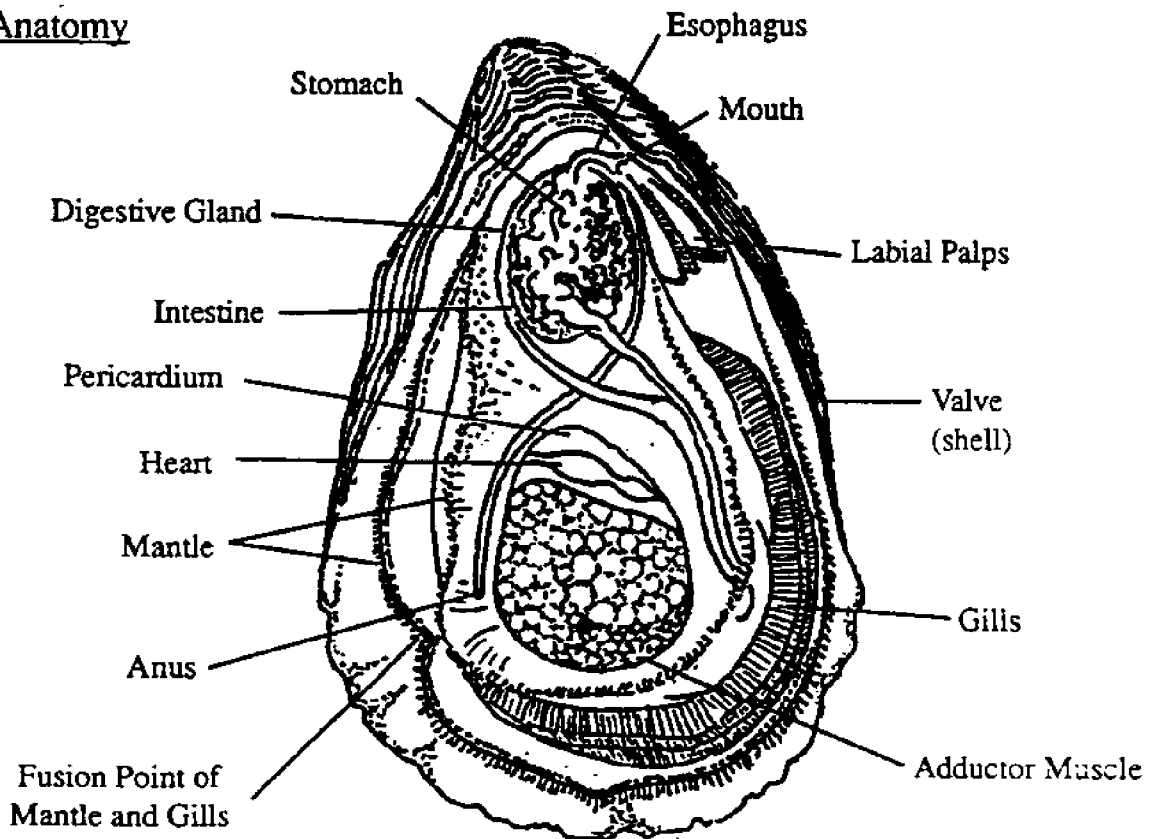

Gulf of Maine Species of Oysters



American Oyster
(*Crassostrea virginica*)

- shells are thick, rough and variable in shape
- upper shell or right valve is smaller and flatter
- bottom shell or left valve attaches with a special glue to rocks or to other oysters in subtidal beds
- a purple muscle scar is visible on the inside of the shell
- large scale harvesting in states of NJ., MD. & VA.



European Oyster
(*Ostrea edulis*)

- shells shapes are less variable and more rounded
- upper valve is flat and lower shell is cup-shaped
- transplanted into Maine waters in 1940
- meat is darker with a distinct black edge
- specifically a cold water animal cultured in Maine and New Hampshire

Oyster Trivia

Have you ever heard the tale that you should never eat oysters during a month that does not have the letter "R" in it? Oysters are available year-round even though they are less marketable during these months which lack "R's." It is during this time period that oysters spawn. Their energy goes into reproduction making their meat soft and watery. Also, masses of developing larvae attach to the gills giving rise to the term "white sick" which make these oysters less desirable.



Oyster Midden

The American Indians once harvested oysters in Maine's estuaries and discarded the shells into piles called "middens." One of these larger middens was discovered in Newcastle, Maine.

Oyster Activities

1. Observations of live oysters

- a) Obtain some live oysters (American and European) from your local fish market or supermarket. Keep them refrigerated.
- b) Place a live oyster in a clear container of seawater. Be sure that the water covers the animal.
- c) Observe and describe its size, color, shape and protective adaptations.
- d) Compare the American Oyster to the European Oyster in its size and shape.

2. Explorations

a) Observations

- Observe and describe the shells: color, shape, texture and the differences between dorsal and ventral shells.
- If it is an American Oyster, locate the scar on its shell which indicates where it was glued to the bottom.
- Carefully observe the shell for signs of spat (young oysters) or other organisms.

b) Shell measurements

- The height of the oyster is the distance from the pointed end or "beak" to the opposite end. If it is less than 3 inches it usually is a male and greater than 3 inches is a female. The oyster has the ability to change sexes which assures successful reproduction.
- The length of the oyster can be determined by measuring the widest part of the shell parallel to the beak.

c) Internal anatomy

- When opening an oyster, grasp the shell with a gloved hand. Place it on a firm surface with the wide edge of the shell protruding past the edge of the surface. Break off the edge of the shell with a hammer. Insert the knife between the broken edges and work the knife towards the umbo severing the adductor muscle.
- Using the diagram of the internal anatomy, locate the following parts: adductor muscle, heart, mantle, gills, labial palps, stomach and gonad.

3. Creating a fossil

- a) Cut the sides of a milk carton so that it has a three inch rim. Press modeling clay into the bottom so that it is one inch deep.
- b) Obtain an oyster shell with an uneven surface. Press it into the clay and then carefully remove it.
- c) Mix plaster-of-Paris, according to the directions, and pour an inch of plaster over the impression.
- d) Let the plaster set for at least an hour. Peel away the milk container and separate.

4. Oyster Stew

- a) Ingredients: 3/4 stick of butter, 1 pint of shucked oysters, 1 pint of milk, salt and pepper
- b) Melt 3/4 stick of butter in a heavy saucepan.
- c) Rinse grit off oysters and simmer in hot butter for a few minutes. Add salt and pepper to taste.
- d) Add a pint of milk and bring it to a near boil. Serve at once with oyster crackers.

5. Read the story The Pearl written by John Steinbeck. This novel is appropriate for seventh grade reading. The Pearl is the tale of a fisherman named Kino, his wife Juana, and the pearl that they found.

Sea Scallop (*Plactopecten magellanicus*)

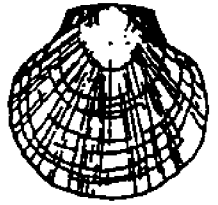

Classification: Phylum: Mollusca; Class: Bivalvia

Description: Sea scallops are mollusks which possess two, fan-shaped shells. A set of distinctive "wings" or "ears" are located where their two shells are hinged together.

Habitat: Sea scallops are found from Labrador to New Jersey in depths ranging from twelve to nine hundred feet. These bottom dwellers prefer a substrate comprised of sand and gravel.

Movement: Scallops swim either forward or backward by contracting and relaxing their large adductor muscle in conjunction with working their mantle curtain. When swimming, scallops move in a zig-zag fashion.

Respiration: Gas exchange is accomplished by two pairs of large gills located in the mantle cavity.

Ingestion: Sea scallops are filter feeders that use their gills to trap minute food particles. Food is passed from the gills toward the mouth by use of cilia. The actual ingestion of food involves the labial palps and the crystalline style.

Growth: The scallop's mantle contains a fleshy layer of cells that is responsible for producing the shell. Sea scallops can grow to be over eight inches in diameter.

Excretion: Waste is expelled out of the anal opening into the mantle cavity where it is flushed out of the shell.

Nervous System: The scallop's nervous system consists of neural centers and their interconnecting nerve cords. Sensory tentacles and more than fifty blue eyes line the mantle edges giving them a general awareness of its surrounding.

Circulation: Nutrients and oxygen are absorbed into the blood. The blood is then pumped by a chambered heart through a system of vessels to the organs.

Reproduction: Sea scallops have separate sexes. They release sperm or eggs into the water during spawning which usually occurs during the late summer months. Following fertilization, the larval scallops pass through a trochophore and veliger stage before they briefly attach themselves to the bottom.

Common Names: "deep-sea scallop," "Atlantic sea scallop" and "giant scallop"

Predators: Sea stars, some species of fish and man are the major predators of sea scallops.

Commercial Value: The 1992 reported landings were 1,419,839 pounds valued at \$7,344,691.

Other Gulf of Maine Species: Iceland Scallop (*Chlamys islandica*), Bay Scallop (*Aequipecten irradians*)

Scallop

External Anatomy

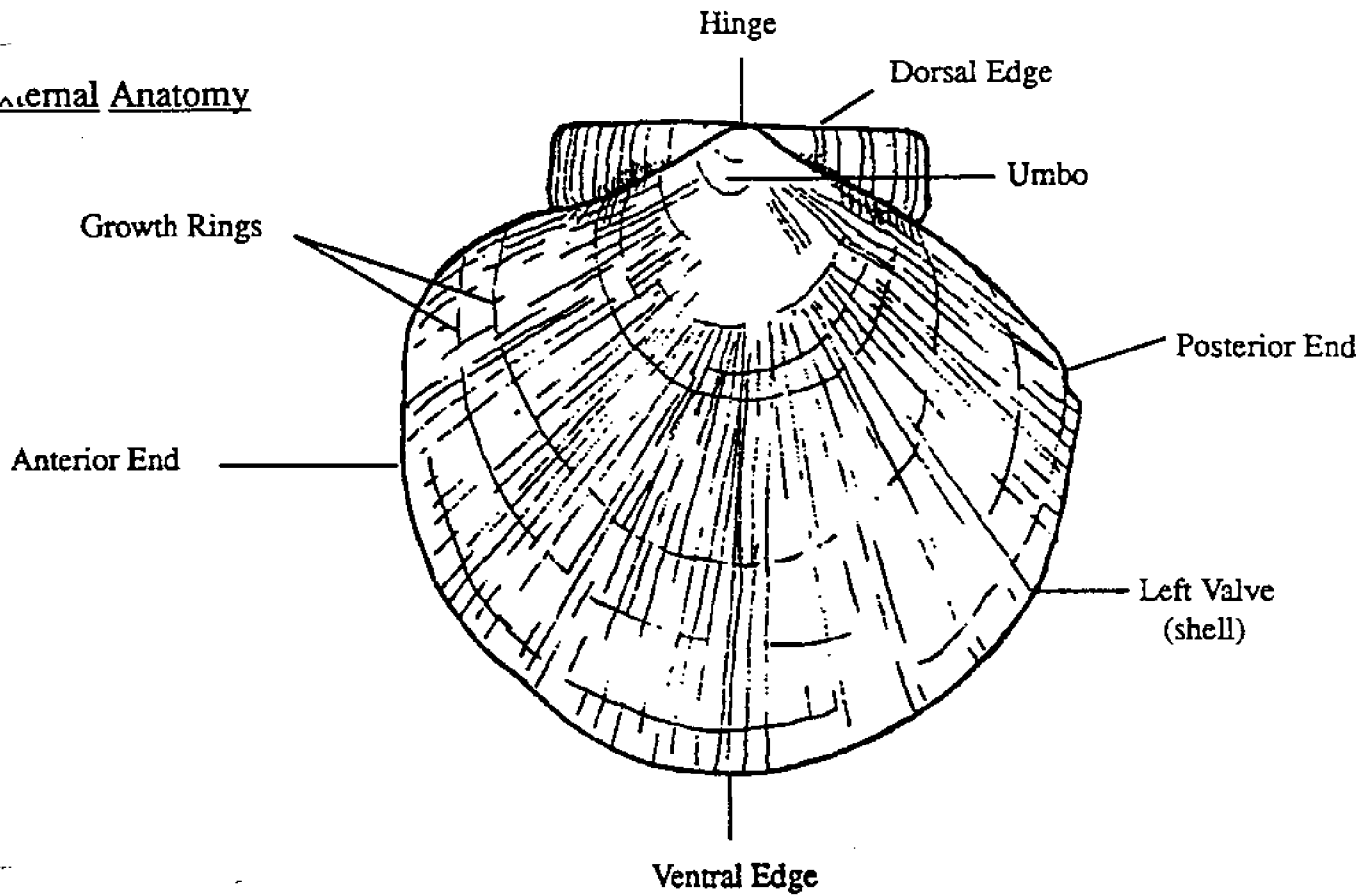

Internal Anatomy

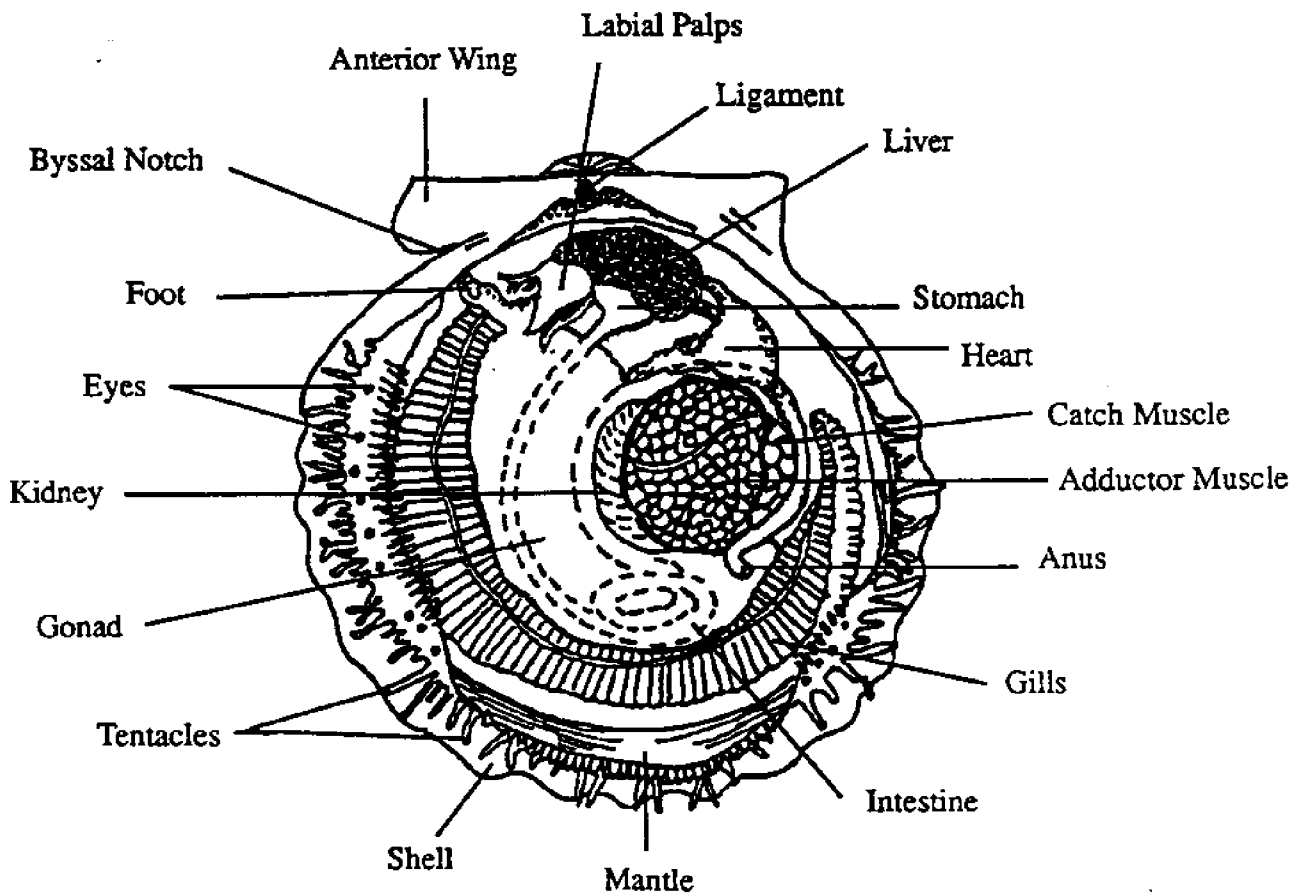

Gulf of Maine Species of Scallops

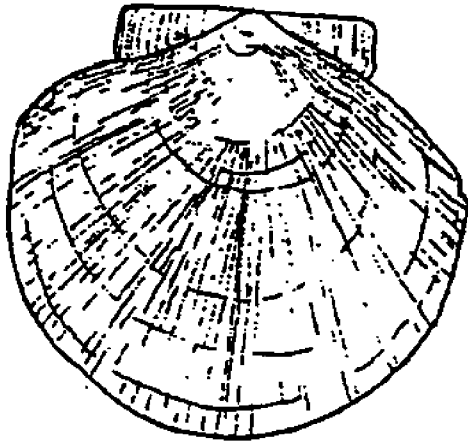

Deep Sea Scallop
(*Placopectin magellanicus*)

- large, smooth, flat, finely-ribbed valves
- wings at hinge line are about equal
- grows to eight inches in size
- harvested off the coast of Maine
- commonly found from Labrador to Cape Cod
- found in deep water south of Cape Cod to N. Carolina

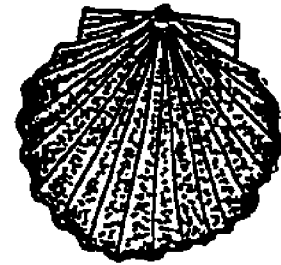

Bay Scallop
(*Aequipecten irradians*)

- small, coarsely-ribbed valves
- coloration varies from drab grey to yellowish brown
- wings at hinge line nearly equal
- grows to three inches in size
- found from Cape Cod to Gulf of Mexico



Iceland Scallop
(*Chlamys islandica*)

- ovoid upper valve with fifty or more ribs
- variable in color
- unequal wings at the hinge line
- grows up to four inches in size
- found from the Arctic Ocean to Cape Cod

Scallop Activities

1. Observations of a live scallop

- a) In order to possess a live scallop, you must have a special permit from DMR.
- b) Place a small scallop in a container of seawater.
- c) Observe and describe its shape, color, movement, and protective adaptations.
- d) Place a live scallop in a tray for a short time. Make detailed observations of its structures and behaviors. (Be aware that the scallop may startle the students as it closes its shells.)
- e) How does this animal differ from the scallops purchased at a store? Attempt to locate its edible muscle when the scallop opens its shells.

2. Observations of scallop shells

- a) Large, flat scallop shells are from the sea scallops which are common to Maine. The smaller, coarsely-ribbed scallop shells are from Bay scallops that are found from Cape Cod south.
- b) Identify the differences between the top and bottom shells.
- c) Examine the inside and outside of the shells. Locate plants or animals, their remnants or scars that may be present on the shell. Common animals which attach or bore into shells are: slipper limpets, barnacles, spirorbis worms, bryozoans, jingle shells, boring worms and boring sponges.
- d) Examine the inside of the scallop shells for the hinge and the scar created by the adductor muscle.

3. Explorations

- a) How does a scallop sense changes in the environment?
 - Locate the small bluish-black dots on the edge of the scallops mantle. Approximately how many are present and what are their function?
 - Use a pencil to gently touch the small tentacles found on the edge of the mantle. What was the scallop's reaction?
- b) How does a scallop move?
 - Place a small scallop in a large container of seawater. Probe it gently with a pencil as a stimulant.
 - How does a scallop move? How do the hinge, adductor muscle and mantle curtain work together to allow this type of locomotion?

4. Art Activity

- a) Scrimshaw
 - Use a sharp nail to scratch a design on the inside of a scallop shell.
 - Generously coat the scratched surface with India ink and allow it to set for a few minutes.
 - Wipe off the excess ink using a paper towel.
- b) Rubbing of a scallop
 - Draw the shape of a scallop and its growth rings on a piece of cardboard. Apply a heavy bead of Elmer's glue to the pattern on this template.
 - Place a piece of white paper over the template and rub it with a crayon.

5. Research Topic: Maine's scallop fishery; including fishing gear, regulations and fishing season.

APPENDIX H

Map of Maine's Aquaculture Sites

(Reprinted with permission from Seth Barker, Maine Department of Marine Resources.)

APPENDIX I
State of Maine Learning Results

(Reprinted with permission from the Maine Department of Education.)

State of Maine LEARNING RESULTS Alignment Index

A. Classifying Life Forms: Students will understand that there are similarities within the diversity of all living things.

2. Describe similarities and differences among organisms within each taxonomic level (kingdom through species).

KEYING OUT FISH
MUSSEL DISSECTION

B. Ecology: Students will understand how living things depend on one another and on non-living aspects of the environment.

3. Analyze the effect of reproductive and survival rates on population size.

AQUACULTURE AND THE GLOBAL COMMONS
WEB OF LIFE

4. Analyze the impact of human and non-human activities on the type and pace of change of ecosystems.

AQUACULTURE AND THE GLOBAL COMMONS
AQUACULTURE DEBATE/TOWN MEETING
STARTING YOUR OWN AQUACULTURE BUSINESS
WEB OF LIFE

E. Structure of Matter: Students will understand the structure of matter and the changes it can undergo.

2. Analyze how matter is affected by changes in temperature, pressure, and volume.

SALTWATER WONDERS

J. Inquiry and Problem Solving: Students will apply inquiry and problem solving approaches in science and technology.

1. Make accurate observations using appropriate tools and units of measure.

FISH MARKET AQUACULTURE SURVEY
DETERMINING NUMBER BY WEIGHT IN FISH POPULATIONS
SALTWATER WONDERS
TESTING WATERS
KEYING OUT FISH
AGING FISH
BONY FISH DISSECTION
MUSSEL DISSECTION
GROWING FRESHWATER ALGAE
MARINE ALGAE AND LIGHT
GROWING CLAMS

2. Verify, evaluate, and use results in a purposeful way.

AQUACULTURE AND THE GLOBAL COMMONS
DETERMINING NUMBER BY WEIGHT IN FISH POPULATIONS
SALTWATER WONDERS
TESTING WATERS
AGING FISH
BONY FISH DISSECTION
MARINE ALGAE AND LIGHT
GROWING CLAMS

3. Recognize, extend, and create patterns and cycles using concrete products and examples of data and ideas or theories.

SALTWATER WONDERS

K. Scientific Reasoning: Students will learn to formulate and justify ideas and to make informed decisions.

1. Judge the accuracy of alternative explanations by identifying the evidence necessary to support them.

AQUACULTURE DEBATE/TOWN MEETING

2. Show that agreement among people does not make an argument valid.
AQUACULTURE DEBATE/TOWN MEETING
3. Develop generalizations based on observations.
AQUACULTURE AND THE GLOBAL COMMONS
MAPPING MAINE'S AQUACULTURE SITES
FISH MARKET AQUACULTURE SURVEY
SALTWATER WONDERS
WEB OF LIFE
BONY FISH DISSECTION
MUSSEL DISSECTION
4. Recognize the need to revise studies to improve their validity through better sampling, controls, or data analysis techniques.
FISH MARKET AQUACULTURE SURVEY
GROWING FRESHWATER ALGAE
MARINE ALGAE AND LIGHT
GROWING CLAMS
5. Produce inductive and deductive argument to support conjecture.
AQUACULTURE AND THE GLOBAL COMMONS
AQUACULTURE DEBATE/TOWN MEETING
7. Analyze situations where more than one logical conclusion can be drawn.
AQUACULTURE DEBATE/TOWN MEETING

L. Communication: Students will communicate effectively in science and technology.

2. Use journals and self assessment to describe and analyze scientific and technological experiences to reflect on problem-solving processes.

AQUACULTURE NEWSLETTER
STARTING YOUR OWN AQUACULTURE BUSINESS

3. Make and use appropriate symbols, pictures, diagrams, scale drawings, and models to represent and simplify real-life situations and solve problems.

MAPPING MAINE'S AQUACULTURE SITES
DETERMINING NUMBER BY WEIGHT IN FISH POPULATIONS
SALTWATER WONDERS

5. Critique models, stating how they do and do not effectively represent the real phenomenon.

AQUACULTURE AND THE GLOBAL COMMONS
STARTING YOUR OWN AQUACULTURE BUSINESS
DETERMINING NUMBER BY WEIGHT IN FISH POPULATIONS

6. Evaluate the communication capabilities of new kinds of media.

AQUACULTURE NEWSLETTER

8. Debate opposing points of view using a common set of information.

AQUACULTURE DEBATE/TOWN MEETING

M. Implications of Science and Technology: Students will understand the historic, social, economic, environmental, and ethical implications related to science and technology.

1. Examine the impact of political decisions on science and technology.

GLOBAL GRAPHING
STARTING YOUR OWN AQUACULTURE BUSINESS

2. Demonstrate the importance of resource management, controlling environmental impacts, and maintaining natural ecosystems.

STARTING YOUR OWN AQUACULTURE BUSINESS
WEB OF LIFE
GROWING CLAMS

3. Evaluate the ethical use or introduction of new scientific or technological developments.

AQUACULTURE DEBATE/TOWN MEETING

4. Analyze the impacts of various scientific and technological developments.

GROWING CLAMS

5. Examine the historic relationships between prevailing cultural beliefs and breakthroughs in science and technology.

AQUACULTURE TIMELINE

