

**CIRCULATING COPY**  
**Sea Grant Depository**



**Northern New England Marine Education Project**

NATIONAL SEA GRANT DEPOSITORY  
PELL LIBRARY BUILDING  
URI, NARRAGANSETT BAY CAMPUS  
NARRAGANSETT, RI 02882

**What Is Our  
Maritime Heritage?**

# **What Is Our Maritime Heritage?**

**A Marine Education Infusion Unit  
on Ships and Sailing**

## **Units Revision Team**

**John W. Butzow, *Project Director***

**Peter Corcoran, *Curriculum Writer  
and Assistant Director***

**Susan White, *Educational Materials  
Design and Production***

**Rick Hardman, *Illustration***

Copyright © 1980 by the University of Maine at Orono.

Permission is hereby granted to classroom teachers and informal educators to make unlimited numbers of copies of any portions of this material for classroom or teacher education uses.

All other rights reserved. For additional permissions write to the Northern New England Marine Education Project, 206 Shibles Hall, University of Maine, Orono, Maine 04469.

# Acknowledgement of Support

*The original editions of these units were supported by the College of Education and the Maine-New Hampshire Sea Grant College with funding from the Office of Sea Grant, NOAA, U.S. Department of Commerce.*

*This edition is based on work supported by the National Science Foundation under Grant No. SER8008177.*

*Any opinions, findings, and conclusions or recommendations expressed in this publication are those of the authors and do not necessarily reflect the views of the National Science Foundation.*

## Contributors

### **NNEMEP Staff**

**Project Director: John Butzow 1975-81**

**Project Assistant Directors:**

**Richard Schlenker 1976-77**

**Les Picker 1977-78**

**Harry H. Dresser 1978-79**

**Peter Corcoran 1979-81**

### **Major Contributors:**

John Butzow  
Clayton Carkin  
Peter Corcoran  
Victor DiSilvestro  
Harry Dresser  
Thomas Duym  
John Eiseman  
Richard Glueck  
Ruth Gruninger  
Deborah Hartney  
Wesley Hedlund  
Mildred Jones  
Win Kelley  
Steven Kilfoyle  
Daniel Lancor  
Jean MacConnell  
Julia Steed Mawson  
Les Picker  
Robert Pratt  
Gail Shelton  
Lorraine Stubbs

### **Staff Assistants:**

Julie Brown  
Deborah Hartney  
Michael Shirley

### **Developmental Art Work:**

Peter Archambault  
Lori Dombek  
Carol Nichols  
Harry Dresser  
William Hepburn

### **Developmental Photography:**

Les Picker  
John Butzow  
Clarence Barber

### **Manuscript Preparation:**

Mary Brown

## **Revised Marine Education Infusion Units for Middle School-Junior High School**

***Have You Been to the Shore Before?*** A Marine  
Education Infusion Unit on Seashore and Aquarium  
Life

***What Adventures Can You Have in Wetlands,  
Lakes, Ponds, and Puddles?*** A Marine Education  
Infusion Unit on Wet Environments

***What is Our Maritime Heritage?*** A Marine Education  
Infusion Unit on Ships and Shipping

***Is Our Food Future in the Sea?*** A Marine Education  
Infusion Unit on Aquaculture and Sea Farming

***How Do People Use Lighthouses and Navigational  
Charts?*** A Marine Education Infusion Unit

### **Original — Trial Editions (For Grades K-12)**

*Clams and Other Critters*

*Marine Art*

*The Aquarium*

*The Beaver*

*The Lobster*

*Whale Multi-disciplinary Studies*

*Our Heritage of Ships*

*Shipping, Ships and Waterways*

*The ABCs of Celebrating Year of the Coast in  
Your School*

*Have You Ever Been to the Shore Before?*

*Blue Mussel*

*Lighthouses*

*Wetlands*

*Seaweeds*

*Aquaculture*

*Navigation*

More than one hundred teachers and members of past NSF sponsored summer institutes have trial tested and critiqued these units.

# Marine Education

## Ocean & Coast Conceptual Scheme

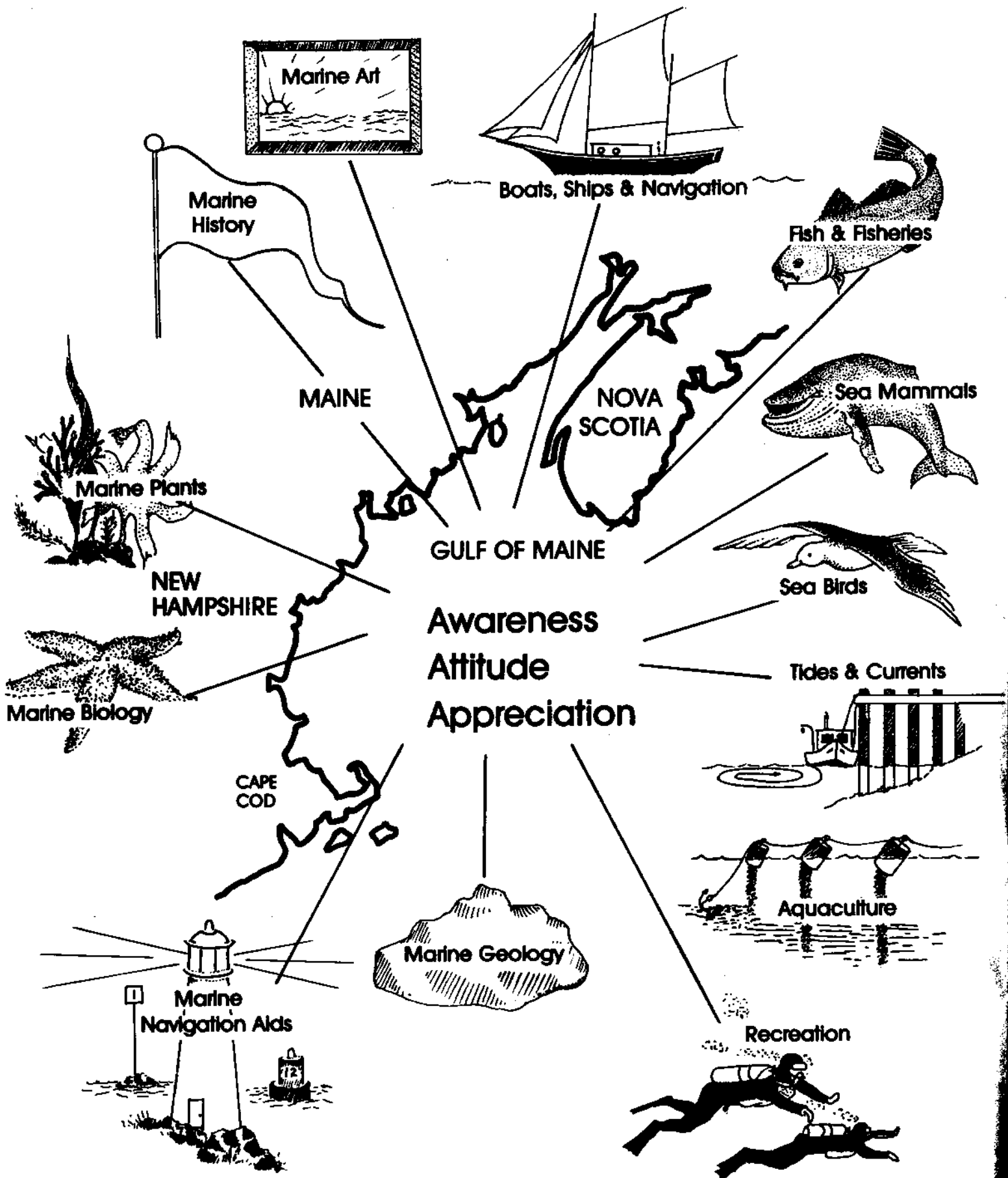

# Foreword

Marine education is a relatively new term embracing a multi-disciplinary approach to learning about the marine environment: how it relates to people and how people change and relate to it. These units are intended to serve as points of departure for teachers and students who desire to increase their awareness of the watery world of this blue planet. Each unit includes ideas and activities drawn from a variety of content areas so that teachers of many different subjects at the junior high and middle school levels can make use of them. These units may be used in their entirety or used as idea or activity sources to infuse into the usual curriculum.

Our objective is to help teachers make learning more water-related. We did not plan a structural sequence of topics for grades 5-9 but rather offer these teachers guides and student pages for your consideration.

The general focus within these units is the Gulf of Maine. As the Gulf extends from Cape Cod to Nova Scotia it washes an extremely long and varied coast. We have dredged and seined themes from the activities, concerns, organisms, vessels and the past of this vast watery region of North America. We aim to be inclusive rather than exclusive, suggestive rather than factual, and stimulating rather than expert. Our hope is that your students will become more questioning, interested, and critical of watery concerns. We hope your use of these materials will add water back into our culture.

John W. Butzow

#### **A Note on Measures and Gender**

The length measurements of vessels in this unit are generally provided in metric units to encourage implementation of the metric system in the classroom. Weights or displacements are described in both long and metric tons. Lengths of traditional boats are retained as is the customary system, for example, as a 16' skiff.

A number of occupational words have as yet no generally used non-sexist equivalent. We have, therefore, retained use of the terms fisherman and lobsterman for either sex.

# Contents Of The Teacher's Guide

<b>Teacher Background Information</b> .....	1
Our Maritime Heritage .....	1
The First Boats .....	1
Native American Boats .....	1
Buoyancy and Flotation .....	2
Building a Whitehall Rowing Boat .....	2
Plans and Process .....	2
Molds and Patterns .....	3
Setting Up .....	4
Lining Off the Planking .....	4
Timbering Out .....	4
Planking .....	5
Interior Joinery .....	5
Masts, Yard, and Sails .....	5
Sail Shapes .....	6
Lines .....	6
Basics of Sailing .....	7
Northern New England Ships and Shipping .....	9
Whaling Vessels .....	9
Clipper Ships .....	9
Downeast Schooners .....	9
The Decline of the Downeaster .....	10
Rebirth of the Downeaster .....	12
Fishing Vessels Under Sail .....	12
Friendship Sloops .....	12
Grand Banks Dory Schooners .....	12
Commercial Vessels Today .....	14
Otter Trawling, Also Called Dragging .....	14
Midwater Trawling .....	15
Longlining .....	16
Lobster Fishing, Also Called Lobstering .....	16
Coastal and Lake Steamers .....	18
<b>Classroom Activities</b> .....	19
The Parts of a Vessel .....	19
Keeping Afloat .....	19
A Paper Boat .....	19
Fan Sailing .....	20
Sail-O: The Game of Sailing .....	20
Block and Tackle .....	21
Chanties: Singing and Work .....	21
Old Ironsides .....	21



Making Scrimshaw .....	22
Life on a Coaster .....	22
Reading <i>Captains Courageous</i> by Rudyard Kipling .....	24
Model Lobsterboat Hull Construction .....	25
Building a Model Walking Beam Engine .....	26
Gathering Local Information .....	26
<b>Teacher Resources</b> .....	27
<b>Places to Visit</b> .....	31
A Directory of Historic Maritime Collections and Vessels .....	31
A Checklist of Marine Oriented Materials and Services .....	33
A List of Boatyards .....	34

## Contents of the Pocket

Lines Plan — Profile  
 Body Plan  
 Whaler  
 Tea Clipper Under Sail  
 A Maine Coasting Schooner  
*Rebecca R. Douglas*  
*Mattie J. Alles*  
*John F. Leavitt*  
 Friendship Sloop  
 Grand Banks Schooner  
 Making Dory Model  
 Bottom Trawl  
 Modern Stern Trawler  
*State of Maine*  
*New Hampshire*  
 Canoe Parts  
 Chanty Music  
 Lobster Boat Hull Sections  
 Walking Beam Instructions

# Teacher Background Information

*The special purpose of "What is Our Maritime Heritage?" is to familiarize teachers and students with our heritage of ships and their importance to us today. It is not intended that the teacher necessarily follow the order, as presented in the unit. Class adaptations reflecting the teacher's preferences are encouraged.*

*Each major ship type or concern is presented as a separate section. Background information is given for the teacher to present to the class as a group, or to individuals for reading. Drawings are synchronized to the background material and are found in the packet.*

*Following the teacher background information section, a series of suggested multidisciplinary activities/projects are listed. It is not intended for every activity to be done by the class. Teacher or student modification and additions are encouraged.*

*Since students will be bringing in articles, projects, and reports concerning the various ship types, it is recommended that file folders be set up to help you organize the material. These could be the basis for reference files for use in the future.*

*Since this is an inter-disciplinary infusion unit, no attempt was made to include an evaluation device for measuring student learning. It is suggested that a test be constructed based on how the unit was used. Objective questions can be drawn from the teacher background information. The most appropriate questions for this unit are aimed at reasoning abilities and synthesizing information. Projects and reports can also be used as a basis for evaluation.*

## Our Maritime Heritage

For thousands of years people all over the world have traded or moved goods over long distances by water transport on either rivers, lakes, or oceans. This is true today even though the types of vessels and the products they carry have changed dramatically. While passengers now rely upon the automobile and airplane for rapid transport to most areas of the world, large freight and fuel cargoes are still moved most efficiently over the waters of the earth's surface. This unit will explore some of the vessel types on which people have relied.



Early Water Transportation

### The first boat

The earliest boats were probably simple logs which people held onto for support when crossing a body of water. In order to move their belongings with them, they had to lash several logs together with vines or reeds which grew near the water's edge. The several logs now formed a floating platform or raft which either drifted on the water current or was pushed as the person walked through shallow water. In deeper bodies of water, people pushed against the bottom of the lake or river with long poles while standing on the raft. The method of propulsion remained in the muscles of the person who owned the boat.

### Native American Boats

Americans found that by carefully burning only the inside of a large tree trunk and scooping out the ashes, they could make a boat in which they could sit, and which would keep their belongings in one place and dry. Sharp rocks and clam shells were common tools for hollowing out the log.

The dugout canoe was easier to push or paddle than a raft and much easier to steer. However, these hollowed tree trunks were very heavy when

removed from the water. Native Americans knew that birch bark is oily and repels water. By inserting wooden frame members into an envelope of birch bark, they created a canoe which was lighter, waterproof, and as long or short as was desired by the builder. Many of the techniques Native Americans used to bend wood for the canoe frame and prepare the bark covering are used today to construct small sail and rowboats.

## Buoyancy and Flotation

Boat float because their weight is less than that of an equal volume of water. While boats may be made of materials which themselves will not float such as steel or concrete, the weight of the boat hull including its skin, ribs and contents, including air, must be less than an equal volume of water or the boat will go down.

Actually, boats are usually much lighter per volume or much less dense than water which weights one gram per  $\text{cm}^3$  (cubic centimeter) or one metric ton (1000 kg) per cubic meter. In a general way, the lighter the vessel is, compared with an equal volume of water, the more of it will be visible above the surface of the water.

The floating boat is held up by a buoyant force which gives the boat the property of being able to float called buoyancy. Buoyant force can be imagined by considering the part of the boat hull that extends downward into the water to be a "hole" in the water which the water constantly tries to squeeze out. The water pushes the hull upward until the boat's weight equals the weight of the water which would fill the hole that the hull makes in the water.

The weight of a vessel can be determined if the portion of the hull which extends below the water level could be cut off and, assuming a negligible hull thickness, filled with water. The weight of the water equal to the submerged part would be the vessel's weight. In international trade vessels, water equivalent weight or displacement is measured in long tons or in metric tons. A long ton equals 2240 pounds. A metric ton equals 1000 kilograms which is equivalent to 2240 pounds in standard measurement.

When commercial vessels are described, the term usually used is not the displacement but rather the maximum safe load weight. This capacity in weight of the vessel is called the deadweight tonnage of the vessel which is the difference between the loaded displacement and the unloaded displacement. The deadweight tonnage is the maximum load capacity of the vessel while its displacement is simply its weight. Both are expressed in either metric or long tons.

## Building a Whitehall Rowing Boat

Today, watercraft are built in a wide variety of sizes and from a vast array of materials. Huge naval vessels are built at the Bath Iron Works of modules or complete segments of metal which include pipes, electrical fittings and other gear. These modules are later assembled into a whole ship. Space-age technology has produced tough laminates of plastics that can be warmed and molded into the hull of a small canoe or rowing boat. This procedure virtually produces a vessel in one step.

Wooden vessels traditionally have been built from small three dimensional models of their hulls, called half models. Scale diagrams, often at a one inch to one foot scale, are then produced. These scale diagrams are called line diagrams or lines plans. The next step is to make a full size set of plans which is done on the floor of a large room. This process is called lofting after the large loft space where it takes place. Next, a temporary framework or mold is built to tie together the boat's backbone structures. Ribs are bent and supported in the mold structure and then the skin or planking is attached. Finally, finishing and interior work is completed.

The following section describes in considerable detail the construction of a wooden vessel. Those not interested in the technical aspects of this process may wish to proceed to the section, "Masts, Yards, and Sails."

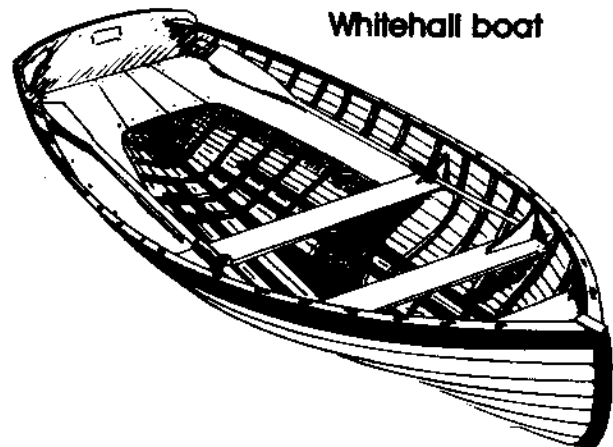

Whitehall boat

### Plans and Process

Our treatment of boat construction will deal with the traditional and recently revived methods for making wooden boats. The following example is largely taken from procedures used at the Marine Trades Center for Washington County Vocational Technical Institute. In this school boatbuilding students make a Whitehall rowing boat as part of the first year of their course.

The work on the Whitehall begins with the selection of materials for construction. Wood must

be strong and water resistant. In our region, white cedar is often best for skin planking while the heavier, stronger white oak is a good selection for backbone structures and ribs. Oak can be steamed and bent which makes it a very versatile wood. Other regionally important woods, such as white pine and spruce for masts and ash in place of oak, should also be noted. Exotic woods not regionally grown, such as mahogany and teak, are often used for trim.

Fasteners must be away from or resistant to the highly corrosive salt water. Silicon bronze screws and copper rivets are preferred below the water line, although some workboats are fastened together with hot galvanized steel. Waterproof glues such as resorcinal or epoxy are preferred.

All joints are coated with a non-hardening compound to keep out water and hence prevent rot. The whole vessel is coated with specially prepared marine paints and varnishes to lengthen the life of the perishable wood. With the necessary materials at hand, actual construction begins with a self-designed plan or half model or alternatively with plans purchased from boating publications, museums, boat designers or copied full scale from an admired craft.

The plan one receives from a designer includes two major parts, the lines plan (profile view and plan or side view) and the body plan including a table of offsets. Since the hull is symmetrical about the center line, or CL, only half of it needs to be drawn.

### The Lines Plan

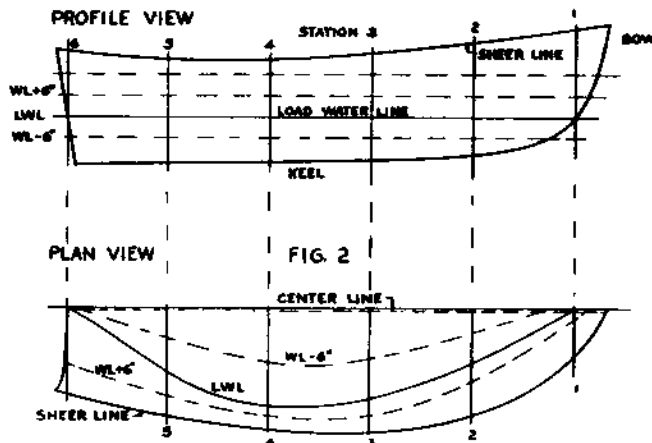

FIG. 2

sections that cut the hull crossways. These stations are placed at even intervals along the length of the boat. Stations are seen as sections in a third view, the sectional view of body plan. The offsets are the numerical measurements given for the various lines at each station. They appear in a table.

Working to a scale of 1" = 1' the designer is limited in his precision. A 1/8" error on the drafting board corresponds to a 1 1/2" error full size. So it is necessary to redraw the lines of the boat full size on a white painted floor known as the loft floor or mold loft. From the full size drawing, patterns can be made. A grid is made with the waterlines and station lines from the profile view. If space is a limiting factor, the plan view with CL and buttocks is superimposed. The offsets are then measured off at their respective locations. When all the measurements for a particular waterline, or WL, have been made, a long straight-grained flexible wooden batten is bent between the individual points giving a continuous curve. The curve is checked by eye for fairness. As the fairing of the lines continues, all offsets are checked and changes are made as necessary, so that all three views (the profile, the plan, and the sectional) agree with each other.

### Molds and Patterns

When lofting is complete, patterns are made out of 1/2" pine or 1/8" masonite for the various keel parts. Also each station is transferred to 1" spruce

### The Body Plan

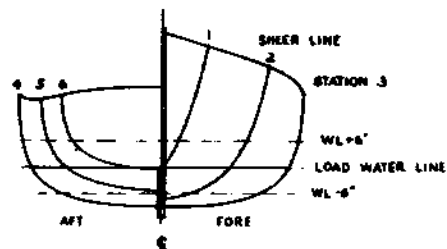

### Table of Offsets

STATION	HALF BREADTH						STATION
	1	2	3	4	5	6	
WL-6"	030	112	200	116	145	087	WL-6"
LWL	020	097	191	087	120	000	LWL
WL-8"	031	132	144				WL-8"

OFFSETS GIVEN IN FEET, INCHES, AND EIGHTHS

The sheer line is the line where the top of the hull and the deck meet. The load water line, or LWL, is the line on the hull which the surface of the water makes when the boat is afloat. Water lines are straight reference lines parallel to the LWL in the profile view. In the plan view, they are also known as water lines and they appear curved like contour lines. Buttocks appear as straight reference lines in the plan view and contour lines in the profile view. The stations are planes that are perpendicular to both the CL and the LWL;

forms, which are called molds. These molds are temporary and are removed as the boat is finished.

One method of transferring the lines to the wood is by laying 4 penny nails on the floor with their heads aligned with the line that is to be transferred. The piece of wood for the mold or pattern is then carefully laid on top of the nails and pressed down hard. The impression of the nail head is left on the piece, which can now be cut to shape on the band saw.

## Setting Up

A strong back is made out of two by fours to brace the keel and molds during construction. The only requirements are that it be rigid and stationary or, if the boat is large, the strong back is sometimes eliminated and the keel is secured to posts which hold it in place. The molds are braced from the ceiling. The keel patterns are then traced on the oak keel stock and the various keel parts are cut out.

The planking rabbet is then cut in the various parts. This is the groove in the backbone where the hull planking will join it. The angle of the rabbet changes quickly at the ends of the boat. The keel parts are bolted together, and bedding compound is first applied. Stopwaters or pine dowels are drilled through the joints in way of the rabbet. The stopwaters swell and prevent water from wicking along the joint and finding its way into the boat.

Molds are then erected on the keel and checked for spacing, plumb, and level, for correct height using a string down the CL of the boat as a reference WL, and for square to CL by measuring both sides of mold from some point on the stem. When all the molds are set correctly, they are securely braced.

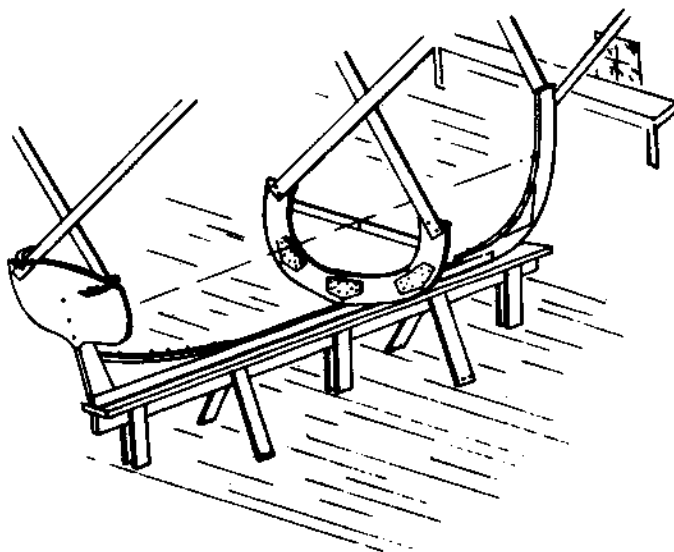

Midship Station Mold braced in place. Typical Strongback Setup.

## Lining Off the Planking

Since the distance from the rabbet to the sheer line varies from the bow to the stern, the plank widths at each station must be found. One method is to make a base line slightly longer than the longest girth (usually just aft of amidships). This line is then divided evenly by as many spaces which are to have planks. From one of the space marks close to the center, one erects a perpendicular with a carpenter's square and then connects the tip of the perpendicular to the various division marks on the original line.

Now, we have a triangular-shaped diagram with rays going from the vertex to the base line divisions. To find the plank width for a given mold, bend a flexible batten around the mold from the rabbet to the sheer line and transfer the sheer line to the batten. Now one uses the triangle for moving the batten parallel to its base line until the two outside rays of the triangle coincide with the measurement on the batten. At this point each ray is transferred to the batten, the batten taken back to the mold and the division lines are transferred to each mold. Now one runs long thin battens along plank lines to check for fairness and adjust as necessary.

## Timbering Out

Ribbands, built up of strips of spruce to a total size of  $1\frac{1}{4}$  x  $1\frac{1}{4}$ " for a small boat to 2" x 4" for a large boat are fastened to the molds in a fore and aft direction every 6" to 12" along the side of the hull. These are temporary and make the boat look like a basket at this point. The insides of the

ribbands are marked for the locations of the timbers.

Timber stock cut out of planks is steamed one hour for each inch of thickness in a steam box. These are taken out one by one and bent into place inside the ribbands. They are then held in place with clamps. Timbering out is fast work. The timbers, sometimes with a little persuasion, bend right into place. It is common to timber out a 30 footer in a day with a crew of three.

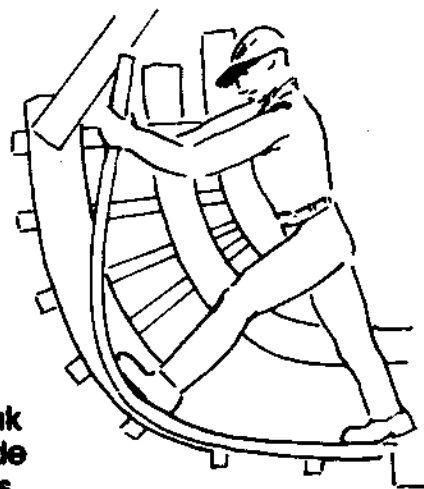

Bending steamed oak timbers inside the ribbands.

## Planking

Determining plank shapes is done by spiling. A flexible spiling batten about 1/4" thick and 3/4" wide is wrapped around the molds, being careful not to set it edgewise. Then a pair of dividers or a thin block is used to span the gap between the predetermined plank line on the mold and the batten. This is done at each mold. The rabbet at the forward end is marked in this manner also. The transom need only be marked appropriately since the plank is allowed to run by the transom to be trimmed flush later.

The first plank to go on is usually the bottom or garboard. This is also usually the hardest to fit because of the curve at the stem rabbet. Sometimes a pattern must be made of the forward end of the garboard to help things out. Once the garboard has been fitted to the rabbet, the widths of the plank at the various stations may be measured and the plank's top edge cut to final shape.

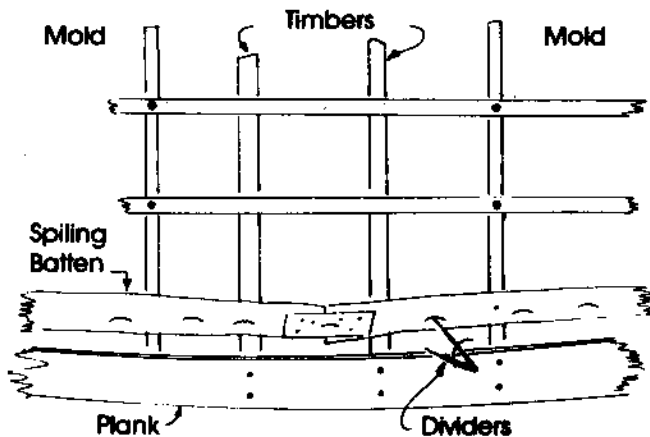

**A Spiling Batten is used to find the shape of each successive plank.**

The sequence of applying planks is usually to start at the garboard then to the sheer strake, alternating and closing in on a point just below the turn of the bilge. The ribbands are removed one by one as they are met in the way of the planking operation. The plank edges must be beveled slightly to make a wedge-shaped caulking seam. A 1/16" gap is formed at the outer edge, tight on the inside. At the turn of the bilge, the planks must sometimes be hollowed out on the inside to lie flush on the timbers.

## Caulking and Fairing the Hull

When the planking is complete, the seams are caulked with cotton. For a small boat such as a Whitehall, the caulking cotton is in the form of thin yard or wicking. This is rolled into the seams with a tool resembling a dull pizza cutter. On a large boat the cotton used is in the form of a continuous

strand of 1/2" diameter cotton batting and is driven into the seams with a mallet and a dull flat-bladed caulking iron. Immediately after the cotton is applied, the seams are painted with primer so that the cotton will not creep out of the seams.

Now the hull is planed smooth. Holes are filled. Final sanding and first primer coat are applied. The seams are then filled with a non-hardening compound and small gouges are filled with a plastic putty.

## Interior Joinery

The hull is primed inside with a primer if it is to be painted; varnished if it is to be bright. The breasthook at the bow and quarter knees at the stern are fitted by making patterns of thin pine to fit and then tracing them on oak stock. The inwales and rubrails are fastened in place. The thwart riser is installed which is a lengthwise batten on which the thwarts rest. The thwarts and thwart knees are installed. Patterns are helpful here. Cleats and oaklock sockets complete the interior carpentry. And then, the final coats of paint are installed inside and out. The toxic antifouling paint is applied to the bottom about twelve hours before launching.

Then it's time to get out the champagne!

## Masts, Yards, and Sails

Not all sailing ships are rigged in the same manner. Specific sailing ships are designed for specific purposes, be it a Clipper ship, freighting Downeaster, or yacht.

On four-masted sailing vessels, the first mast nearest the bow is the foremast. The masts following are the mainmast, the mizzen, and the jigger.

Sail plans can designate over thirty separate sails on a single vessel, but we can classify sailing vessels by the mast and yard arrangement. A yard is a wooden crosspiece from which sails hang on a mast. There are two major types of sail plans; square rigs and fore-and-aft or schooner rigs.

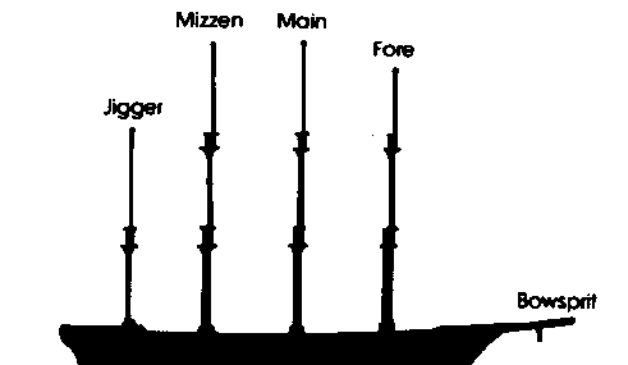

**Masts on a Four-Masted Bark**

## Rigging of Ships

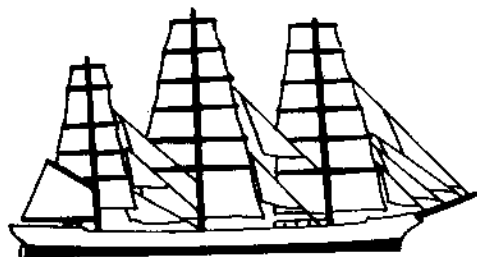

Ship

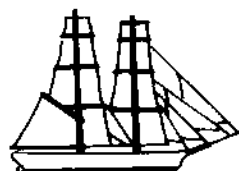

Brig

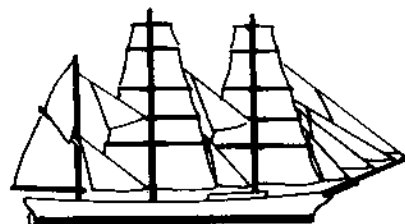

Bark

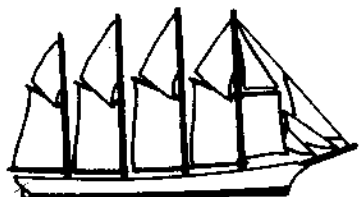

Four Masted  
Schooner (Downeaster)

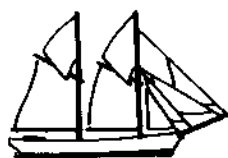

Schooner



Sloop

Square rigs are four-sided canvases (though not always exactly square), schooner rigs are large triangular canvases. The combinations of these rigs as they are hung from the masts determine the type of ship.

Not all sailing vessels are ships. Ship rigging implies that three or more masts must all be square-rigged. Two-masted vessels with square rigging are called brigs. A vessel with at least three masts, the fore and main masts square rigged, and the mizzen mast schooner rigged, is a bark. Vessels with at least two masts, all of them schooner rigged, are simply schooner no matter how large. Sloops are small one masted vessels, fore-and-aft rigged with at least a jib and main sail. Usually, the name sloop is used with a small vessel whose mast is somewhat forward of amidships.

### Sail Shapes

Sail shapes are not completely square and triangular, some are gaff sails in which the shape is like a triangle with the top point eliminated.

Fore-and-aft rigged vessels usually had masts made in a single piece. A few, topsail schooners, had square-rigged sails set above the triangular fore-and-aft sails and, therefore, had several pieces to their masts. Pieces and sails were named from top to bottom. The names for sails are royal, topgallant, topsail, and course. For masts, the pieces are royal, topgallant, topmast, and lower.

### Lines

Square-rigged vessels are designed to catch the maximum wind, providing it comes directly from behind the intended direction. When winds were

### The Parts of a Sail

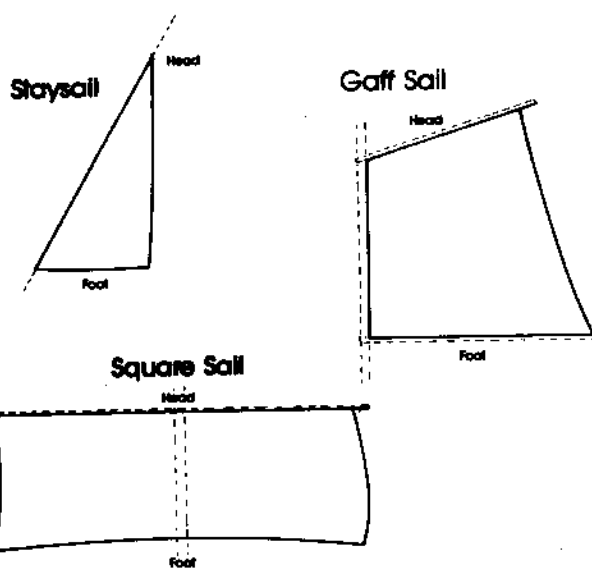

### Masts, Yards & Sails of a Square Rigger

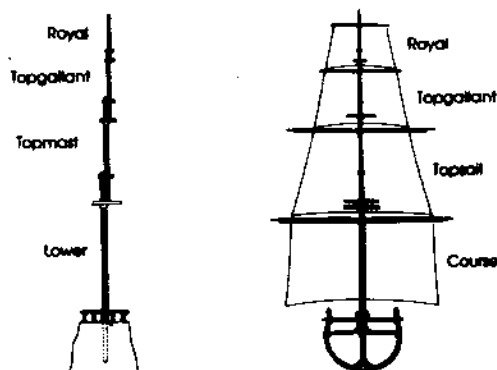

## Lines that control the sails

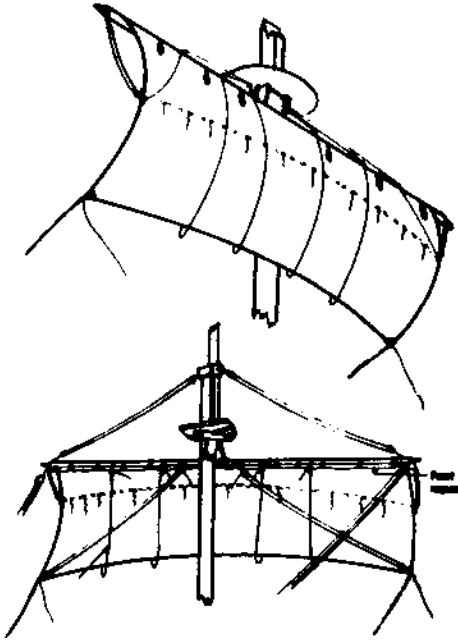

## Block & Tackle

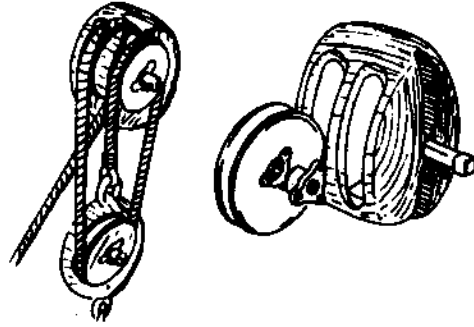

## Basics of Sailing

To learn to sail safely requires a great deal of time and should be taught by an expert teacher. In this treatment only the most basic points can be described. The perfect situation for either the square-rigged or fore-and-aft rigged vessel is with the wind astern. The sensation from the vessel on a warm day should be most pleasant. With a frictionless hull, boat speed would be the same and into the same direction as that toward which the wind blows. You look astern and see a nice wake indicating good speed, sails are nicely bellowed and there is no apparent wind on you.

unfavorable, yards could be hauled to adjust the angle between the sail and wind but this was very limited. Since canvas became extremely heavy when wet, and in the days before synthetics, also rotted easily when wet, stormy weather signaled that the sails needed to be furled or rolled up on the yards. This was accomplished by sailors who stood on the foot ropes and leaned over the yard while they pulled up the sail hand over hand. This work often had to be accomplished in the dark, in a driving rain.

Conditions such as that rarely occur. It is easy to see that a sailing vessel cannot sail directly into the wind. While the closeness to the wind direction will vary because of ship design, for the purpose of this unit, let's use the value 45 degrees from the wind direction as our cut-off value. This means that when the angle from the intended course to the wind direction becomes less than 45° you must either furl sail or change course. With a large square rigger and a very strong wind, the choice may well be furl sail.

Working a fore-and-aft rigged vessel could be largely done from the deck. Often when unfavorable weather set in, the sail tension could be released, the sails luffed up and left until favorable winds returned.

Usually the alternative is to sail a zig-zag pattern in which the overall course is in the intended

Sails, yards and lines are adjusted with pulleys which are called blocks because the body of the pulley is cut from a single wooden block. The wheel part of the pulley is called the sheave and the axle on which the sheave rotates is the pin. An arrangement of a pulley and lines is called a block and tackle. In our illustration we have one block with a single sheave and one with two sheaves. The mechanical advantage of such an arrangement is the ratio of the weight to the force needed to lift it:

$$\text{Mechanical Advantage} = \frac{\text{Weight}}{\text{Force}}$$

As a generalization which ignores the friction of the lines on the sheaves, the mechanical advantage is equal to the number of lines that actually support the weight. In our illustration there are three lines supporting the weight, so we would expect a mechanical advantage of three. More or less lines and blocks can produce much more or much less advantage. This help is welcome to lesson backbreaking labor.

Limit of angle between wind and course, which allows ship to move ahead.

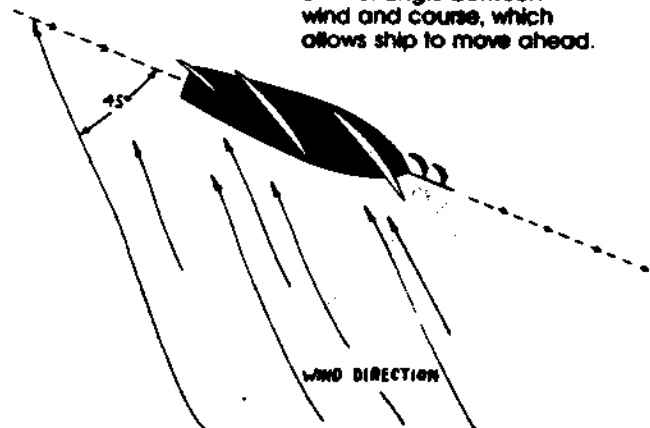



## Tacking a Square Rigger

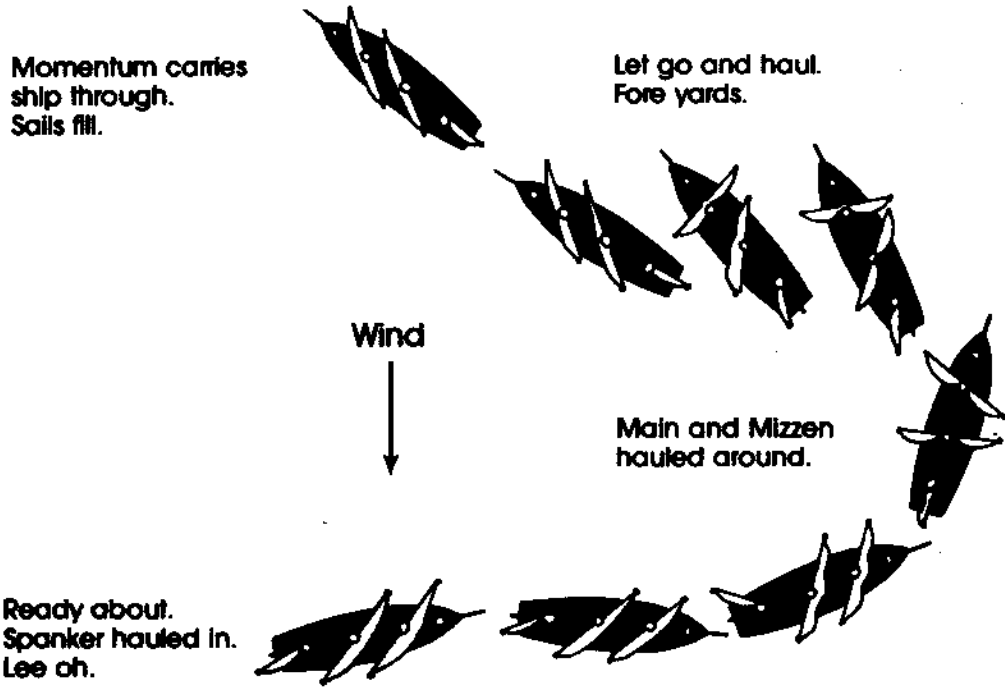

## Wearing Ship

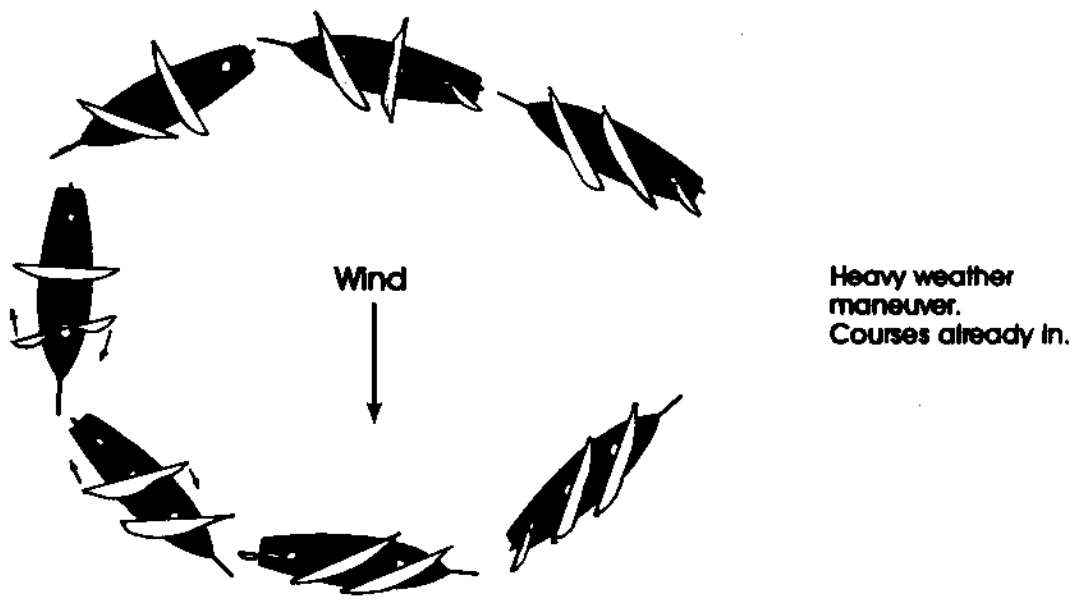

direction but course is altered to alternatively let the ship's momentum carry it through the wind and let the wind push the vessel.

This procedure is called tacking. Tacking a large square-rigged vessel can be a massive undertaking for a score of men. If the wind were very strong it might be better to sail around in a circle to avoid problems — a process described as wearing ship.

Tacking a fore-and-aft rigged vessel is usually much simpler. The sails are slackened as the vessel moves through the wind while the lines and sails are hauled to the other side. With a winch or a small gasoline engine a fairly large schooner rigged vessel can be tacked by a very small crew.

## Northern New England Ships and Sailing

### Whaling Vessels

One of the most important industries of New England during the 1800's was directed to hunting whales and producing whale oil as a fuel and lubricant. Other parts of the whales were used for perfumes and skirt hoops. The whaling fleets sailed out of New Bedford, and Nantucket Island, Massachusetts, Mystic, Connecticut, Portsmouth, New Hampshire, and Portland, Maine as well as many other coastal ports. Voyages were often three years long and the work was dangerous and dirty. Often whaleships disappeared without a trace in the Atlantic or Pacific Oceans. When a ship returned successfully, the owners and crew would divide many thousands of dollars in profits.

Whaleships were generally around 37 meters long and had many different sail riggings. Each ship was equipped with four or six whale boats which were lowered to chase and capture the prey. Each of these boats had to be rowed by a crew under the direction of the harpooner. A harpoon is a sharp, barbed spear which was attached to a rope. Dead whales were towed back to the ship where the fatty blubber was removed and boiled down into oil. The ship's carpenter was kept busy building oil kegs and repairing whaleboats.

The whaling industry began to die out in New England with the discovery of underground petroleum in Pennsylvania in the late 1800's. The last whaling voyage from New England, which was in 1925, lasted only two days when the bark *Wanderer* sailed from New Bedford, only to be wrecked in a storm on Cuttyhunk Island.

There is only one remaining whaleship from the New England fleets in existence, the *Charles W. Morgan*, which is on display at Mystic Seaport in Mystic, Connecticut.

During the long voyages, sailors would carve designs or scratch pictures into whalebone as a pastime. This was known as scrimshaw. Usually scrimshaw pictures were of what was available to sketch. We therefore have a good idea of what a

sailor thought of and appreciated most during those years at sea. Often pictures were of other ships, sailors, or the wives left back at port.

### Clipper Ships

Clippers were the fastest sailing ships to ever enter merchant service. They sped across the oceans from New York and Liverpool to India and China, carrying back tea, spices, and silk. The market prices for these goods were highest for those shippers who could supply them fastest, which explains the quest for speed.

This design of the ship was invented and built by Donald McKay, originally of Nova Scotia. His Boston yard produced ships which bore names suggestive of speed and greatness, such as *Flying Cloud*, *Lightning*, *Nightingale*, *Ariel* and *Black Prince*. The last clipper built was the *Glory of the Seas*, in 1858.

Clippers featured large, square-rigged sails, and tall, sharp bows and sterns. This shape helped the ship plunge through the seas, and cargo space was sacrificed to streamline the vessel. Because clippers were built for speed, their masters pushed them to the limits of their designs. Sometimes a ship would plunge into a large wave at high speed and never come to the surface again.

Clipper ships remained in service until steamships proved more reliable. While clippers sometimes could move at speeds of 19 knots (35 km/hr), which was faster than steamships of the day, steamships had the advantage because they did not slow down when the wind died. These proud, beautiful, romantic ships ended their days as barges, hauling fertilizer from Africa to Europe. The last clipper ship in existence is the *Cutty Sark* in England.

### Downeast Schooner

The coasts of Maine, New Hampshire, and Massachusetts were the greatest producers of sailing ships in the world, due to the abundance of lumber. The sailing vessels built on the coast were designed to carry freight — lots of it — around the world or up and down the American coast. Downeasters had greater cargo space than clippers due to their long, boxy hulls. These vessels were not designed for speed, but to move freight cheaply and in great volume.

Schooners and ships were commonly built with three, four, five, or six masts. Only one ship, the iron-hulled *Thomas W. Lawson*, was built with seven masts. The size of the *Lawson*, 135 m x 17 m, was her undoing, as she proved too big to turn in a breeze and was finally lost in a storm off England. The largest schooner built in Maine was the *Wyoming* built in Bath in 1909.

Schooners from Bath and Searsport, Maine continued to be built until the end of World War I. Some were sent to Florida to move supplies in when that state was developing; many were burned or sunk, some abandoned. Today, the remains of

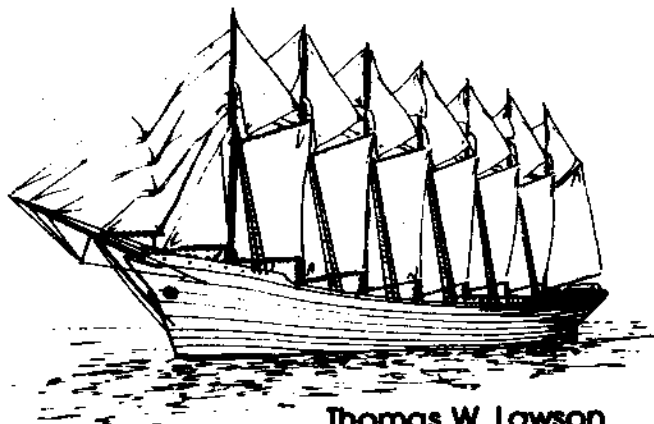

Thomas W. Lawson

the *Luther Little* and the *Hesper* can be seen in Wiscasset, Maine. The hulk of the five master, *Cora A. Cressey* rests in Bremen, Maine while other hulks can be seen in Boothbay and Frankfort, Maine. These are representative of all that remain of hundreds of ships born along this coast.

There are still sailing ships afloat as museum pieces in New York, Philadelphia, and San Francisco, to name a few places. While these ships are mostly of European origin, they still bear the designs and dimensions of the Yankee Downeaster.

### The Decline of the Downeaster

Sailing vessels played a most important role in the history and development of the States of New Hampshire and Maine. This region has been one of the leaders in wooden shipbuilding and world-wide commerce since the founding of our country — more especially during the golden age of sail in the 1800's. The great fleet of downeasters built during the latter part of the last century represented the area's greatest success. The building of the railroads eventually dealt a severe blow to the sailing vessels. However, the major factor that resulted in the disappearance of the small coasting schooners, which were once so prevalent, was the use of motor trucks in the transportation of freight and produce to the remote coastal areas not served by the railroads.

Sailing vessels were of various sizes and rigs, depending upon the uses for which they were built. Ocean going ships were built for foreign trade and were square-rigged vessels. The two-masted crafts were brigs, or topsail schooners, and the three or four-masted crafts were brigs, or ships.

Square-rigged vessels which were used for long ocean voyages had a tendency to perform better than the schooners in heavy seas, and there was less wear and tear on the ship and the rigging. However, because they required a much larger crew to man and were more costly to operate than the schooners with their fore-and-aft rigs; they were replaced by the schooners in the coastal trade. By the turn of the 20th century, nearly all sailing craft built in the United States were fore-and-aft rigged.

It should be noted that the development of the steamship also had a great deal to do with the eventual disappearance of the sailing craft. Steamships proved more dependable in reaching their destination at a specified time, and required smaller crews to operate them. Large schooners were used chiefly in the coal trade along the Atlantic Coast, and were later also replaced by barges and steamships.

The building of sailing vessels was widely spread along the Northern New England coast, especially so during the latter part of the 19th century. After 1900, very few schooners were built and only the older established yards remained in business. Most of the schooners built after 1900 were the three, four, five, and six masters. Some of the ships were built for private owners, some for large shipping companies, and many were built for a large number of shareholders. The most usual share breakdown was 64ths. In this way, if a ship was lost it would be possible for as many as 64 individuals to share the loss of the craft on an equal basis. It was possible for individuals to hold several 64ths, such as 1/32, 1/16, 1/8, 1/4, or 1/2 with each of the last stated fraction parts based on 64th. The builders, local merchants, shipping agents, sea captains, or any interested party could become a shareholder.

Between 1900 and the outbreak of World War I, shipyards sprang up in many coastal communities that had not been building vessels for years including Bath, Rockland, Thomaston, Waldoboro, Camden, Phippsburg, Richmond, and Milbridge.

With the close of WWI and certainly after 1922, the building of commercial sailing vessels came to an end. A few small bay coasters were built in Stonington, and a large two-masted schooner, the *Anna Sophia* was built in Dennysville. The last commercial sailing vessel built in Maine was launched in 1938. It was the schooner *Endeavor* built by the Billings Brothers on Deer Isle.

In the mid 1900-1910 period, a 350 ton three-masted schooner could be built for approximately \$25,000. But, during the World War I period, the cost had escalated to \$75,000 or \$90,000. Four-masted schooners cost from \$175,000 to \$200,000. Most of these schooners never made enough money to pay for their original cost.

When freights became unobtainable, the schooners had to be laid up, and many were sold for very small sums — for less than \$1,000. A few of the large schooners continued to operate until World War II when the demand for ships of any type increased. Many of the schooners that had been out of commission for years were recommissioned and pressed into service. At the close of that conflict the demand for commercial craft virtually ended, with the exception of the smaller bay coasters that remained in use for several more years in transporting pulpwood and other bulky cargos.

The cargoes of the coastal schooners usually consisted of lumber, laths, or pilings when going from Maine or New Hampshire to the Westward. Some vessels specialized in carrying granite or building stone, others in carrying limestone. Before

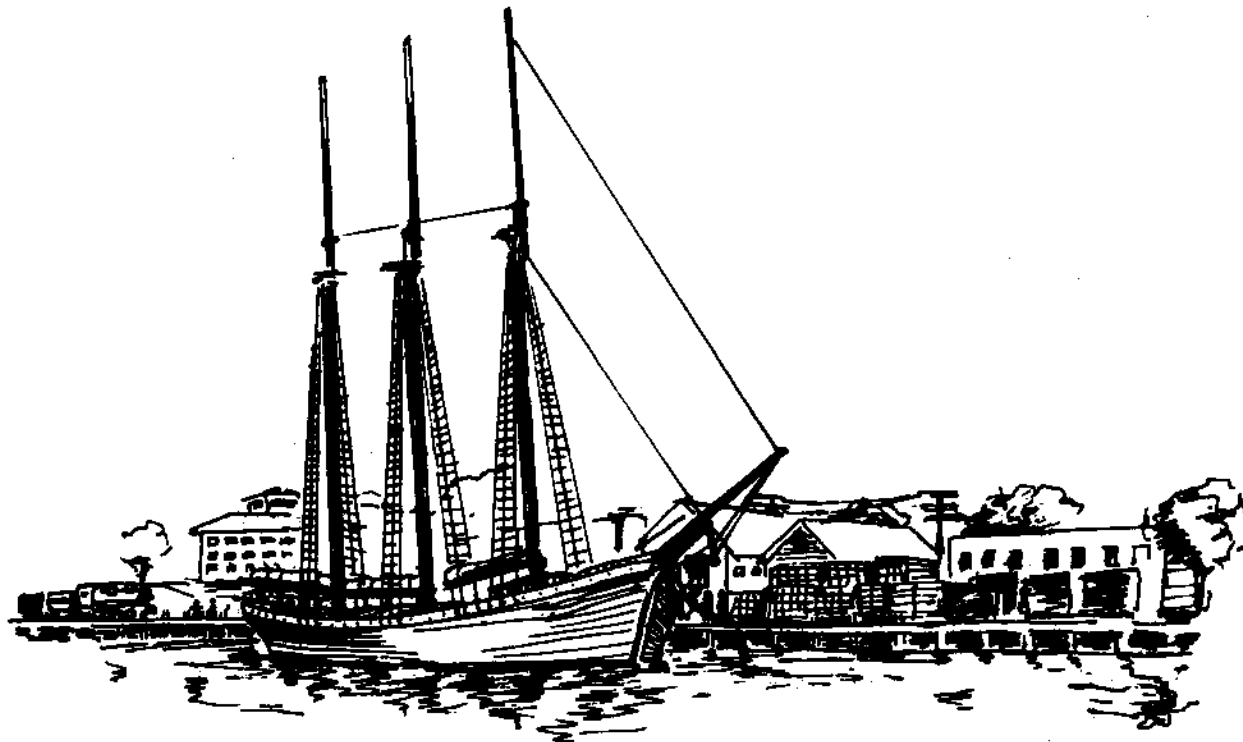

Loading lumber

the days of electrical refrigeration and the manufacture of artificial ice, many large schooners were engaged in carrying ice to various Atlantic coast ports. Some even carried cargoes of ice to foreign countries. The small schooners, called bay coasters, carried cargoes of cord wood, pulp wood, kiln wood, and some were regularly engaged in general freighting. They supplied the coastal communities with food and other materials that could reach the areas by no other means of transportation.

The larger schooners that sailed to New York, or beyond, were almost always able to obtain a load of coal for the return trip to Maine. Schooners in the Boston trade were sometimes able to get partial loads of freight on the return trip.

Most of the coastal shipping was carried on from late March to late November or early December and the vessels were tied up during the winter months. The large schooners usually kept their sails bent, that is, attached to the gaff and boom during the winter. However, they were furled in such a way that no material damage could be done to them. It was not a long tedious job in getting the vessels ready for sea in the spring, unless some major repairs had to be made. The painting was usually done during the time that might be available between trips, and in some cases during the trip itself.

Since schooners did not operate in the winter, crews were usually without work during the long winter period. Some of the schooners, however, made a trip to the West Indies during the winter months to give year round employment to the

vessel and crew. Wages for the crew were low. Seamen were paid from \$35 to \$50 per month, mates from \$50 to \$75, cooks from \$60 to \$75 and captains from \$100 to \$150 per month. In most cases the seamen found it necessary to obtain employment on shore during the winter months in order to obtain a living wage. The captains, however were usually free during the winter, and it was a common sight to see a group of them gather at a country store where they would spend countless hours recalling incidents that had happened during past sailing seasons.

In the mid to late 1920's, wages increased approximately \$10 per month for each category of the crew, and as the number of sailing vessels decreased, it became increasingly difficult to obtain qualified crew men. Considering the minimum length of a working day was twelve hours during sailing, and possibly more during adverse weather conditions, it is easy to see why crews for the schooners were hard to find.

Nationwide regulations also hastened the demise of commercial sailing in coastwide trade. One such regulation was the U.S. Coast Guard rulings requiring Plimsoll Marks — lines painted on the hull of merchant vessels showing lawful submergence levels. Another regulation was the requirement of the Longshoreman's Union that no ship's crew should be engaged in unloading cargo. The first regulation resulted in the vessels carrying less cargo, thus lower revenue, and the second meant keeping a crew on pay during the unloading process. The two regulations proved to be too much to overcome, and commercial sailing for the

large schooners became a thing of the past on the Atlantic Coast.

Several years ago our project had the pleasure of spending several days with "Win" Kelley of Fairfield, Maine. Mr. Kelley was an educator and retired from the headmastership at the Hinkley School. During his late teens and college years, Mr. Kelley, like many Washington County Mainers, sailed aboard the schooners. He provided us with information and photographs of several vessels on which he served. We have adapted these to the sketches that follow. Captions are in the first person and were written by Mr. Kelley.

*Schooner Rebecca R. Douglas of the Small Fleet of Machiasport. Built at Bath, Maine in 1895, 143 feet long, and registering 476 tons. The schooner had a raised deck for carrying kiln dried lumber, and later coconuts for the Baker Extract Company of Philadelphia. A beautiful schooner, a fine sailor, and an easy ship to handle. In fact, I tacked ship alone one night during a twelve to four watch. No problems encountered. Crew consisted of captain, mate, cook, and three seamen.*

*Schooner Mattie J. Alles, 128 feet long, 228 gross tons, built at Yarmouth, Maine in 1883. In later years owned by Captain L.B. Wallace and Everett Wallace of Milbridge. The Mattie J. was a beautiful schooner, always kept in Bristol fashion, looking like a yacht. A fine sailor, and a handy schooner to sail. Captain Wallace, an uncle of mine, was an excellent skipper. He sailed the schooner until the bottom fell out of coastwise shipping. The schooner was then sold in Nova Scotia where she finally ended her days. The picture of the schooner under sail shows her on a trip from Parrsboro, Nova Scotia to Boston with an enormous deck load of lumber.*

**Rebirth of the Downeaster.** The downeast schooner era was briefly reborn during the fall of 1979, when the newly-built two-masted schooner *John F. Leavitt*, captained by Ned Ackerman set off from Quincy, Massachusetts with a cargo of \$22,000 worth of lumber and tanning chemicals for Port au Prince, Haiti. The vessel was lost late on the afternoon of December 27, 1979 in a storm about 250 miles off the coast of Long Island, New York. Unlike what would have happened to their forebears of a century ago, all hands were rescued by U.S. Coast Guard helicopters.

The loss of the *Leavitt* is shrouded in controversy. Ackerman's vessel was engineless except for a powered yawl boat which may have been useful in port areas during good weather but could not be deployed from its position above the stern during rough weather. Ackerman wanted a purely sailing vessel for a number of reasons, including the fact that having no engine power allowed him to avoid compliance with a number of federal regulations. Ackerman and his crew had limited experience which may have contributed to their tragedy. Much has been written about the

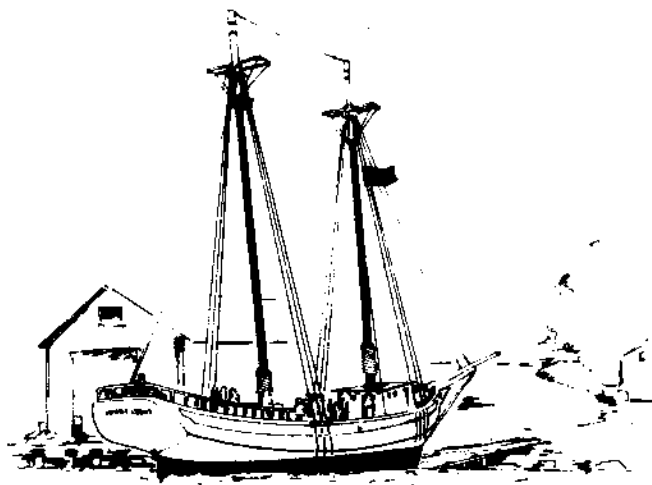

**John F. Leavitt**

building of the *Leavitt* as well as its demise. A special section of newspaper and magazine references is provided in the bibliography.

## Fishing Vessels Under Sail

**Friendship Sloops.** The Friendship Sloop was designed in Friendship, Maine, around 1897 as a work boat for one, two, or three men. In the days before powered boats were available to fishermen, the fleets relied on the wind in their sails to get around. This boat was built to be wide for stability on the ocean and to hold cargo. Friendship sloops had deep keels so that plenty of sail could be carried aloft without endangering the boat's stability. Small Friendships could be managed by one lobsterman, handling the rudder and sails from one area of the boat. When he was finished fishing for the day, the large sails got the lobsterman to port quickly and safely. Friendship Sloops were capable of joining the fishing fleets on the Grand Banks of Newfoundland, miles out on the Atlantic.

Today, these sturdy little crafts are still built with engines as well as sail. But, now they are built as pleasure crafts, not fishing boats. Hundreds of the fast vessels meet each year in the Gulf of Maine off Friendship to race against each other.

**Grand Banks Dory Schooners.** Until the development of fully powered fishing trawlers, fishermen used to sail out to the Grand Banks of Newfoundland in pursuit of mackerel, herring, cod, and other groundfish in two-masted schooners called salt bankers. These vessels were about 44 meters long and had enormous holds where fish were salted and iced to preserve them during the voyage. Fishermen handlined from dories that set out from the schooner.

Periodically these vessels, both American and Canadian, would race for enjoyment over complex courses in the Gulf of Maine. Each season as the fleets gathered on the fishing grounds, old

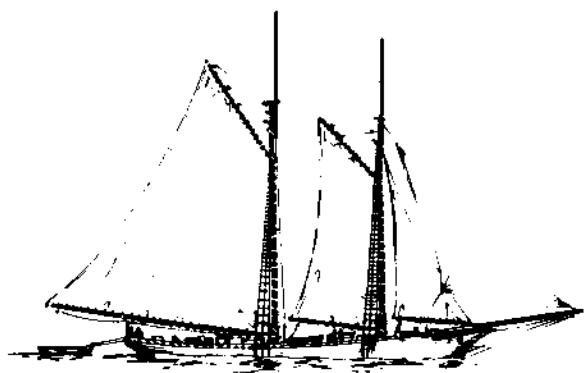

**Mackerel Seiner**

Yet as late as 1965, Portuguese fishermen could be found handling for cod from dories around a schooner.

The occupational hazards were numerous and the loss of life and property was an accepted fact of life to fishing families. These vessels had no radios or radar. A sailor might turn and discover an iceberg drifting into him. Worse than the icebergs were the ocean liners, which relentlessly sliced across the fishing fleet at high speed, hoping something wasn't in their path. But the worst foe of fishermen was the fog which could last for days and obscure all vision.

How well did they do their job? In the first twenty years of this century 1,100,000,000 pounds of codfish were brought in from the Banks annually. One billion, one hundred million pounds of individual fish, caught by hand!

Aboard the *We're Here*, a schooner later burned by the Confederate navy, profits were divided up by count. That is, the fisherman who caught the most fish received the most money for his work. Otherwise profits were divided up in shares called lays. Each fishing crew member received an equal portion of the sale price of the catch, after the owner had deducted his expenses for operating the vessel which included bait cost, insurance, food, and so on. The skipper usually received one third share of the gross profit. On a typical ten day voyage an especially good catch might net a man \$76.00.

friendships were renewed among the sailors and owners.

There are a few of these vessels in museums in Maine and Nova Scotia. The rest have been scrapped or lost at sea. The most famous salt banker was the schooner *Bluenose*, out of Lunenburg, Nova Scotia, whose image appears on the Canadian dime. American schooners have been on the fishing ground since before the Revolution, though many were destroyed during the Civil War.

Schooners on the Banks are no longer a common sight, having been replaced over the last fifty years by diesel-powered dragners and seiners.

### Nova Scotian Deep Sea Fishing Schooner

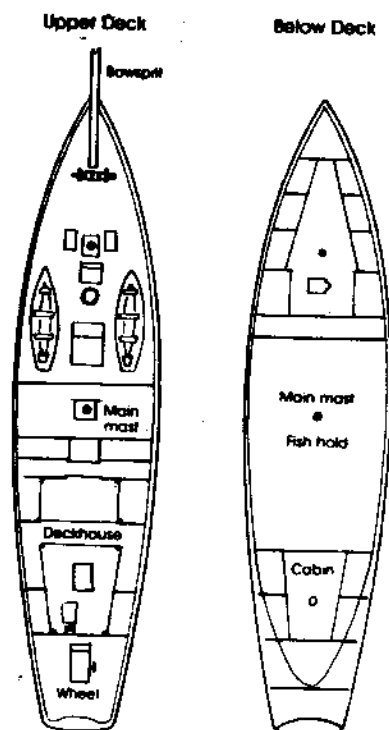
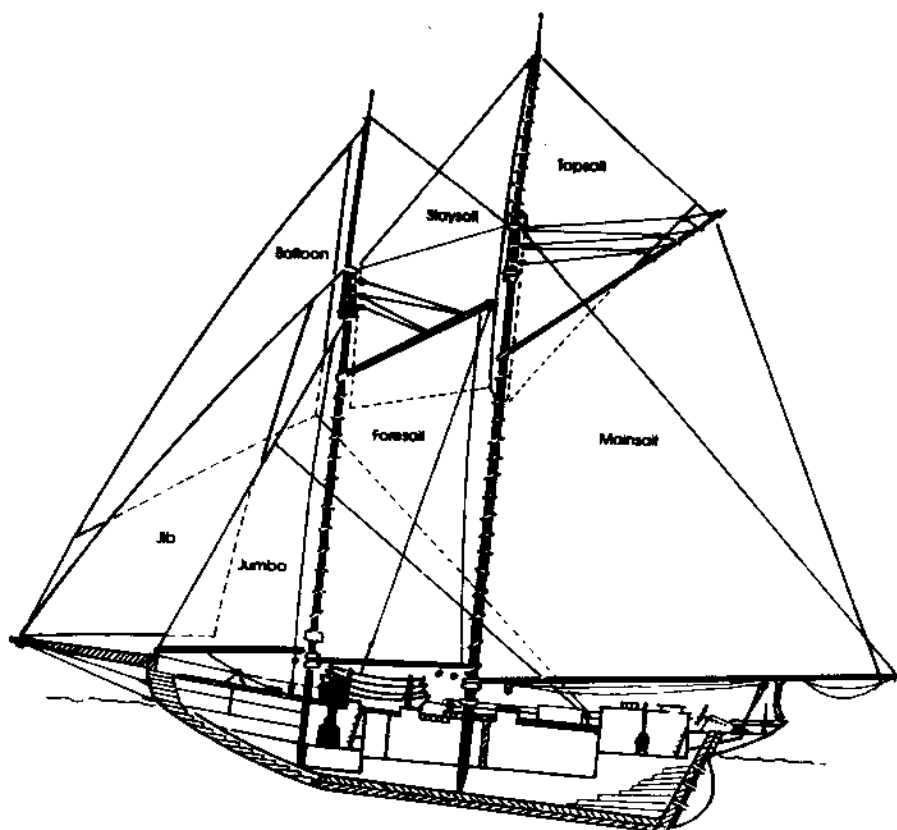

What became of the schooner fleets? While the dory is still used to tend nets on the fishing grounds, fishing with individual hand-held lines has given way to seining. Powered boats drag huge nets through the water and scoop up all the fish in their path. Larger catches are netted this way, but the fish are becoming more difficult to find each year due to the loss of breeding stock. While U.S. and Canadian fishermen still go out in smaller powered boats, great foreign fleets, primarily from Russia, East Germany, and Poland use enormous vessels which remain on the Banks year round, being tended by small ships of the fleet. A few schooners remain in museums in Nova Scotia, Maine, and New York but most lay on the ocean floor -- victims of fires, storms, reefs, or ocean liners.

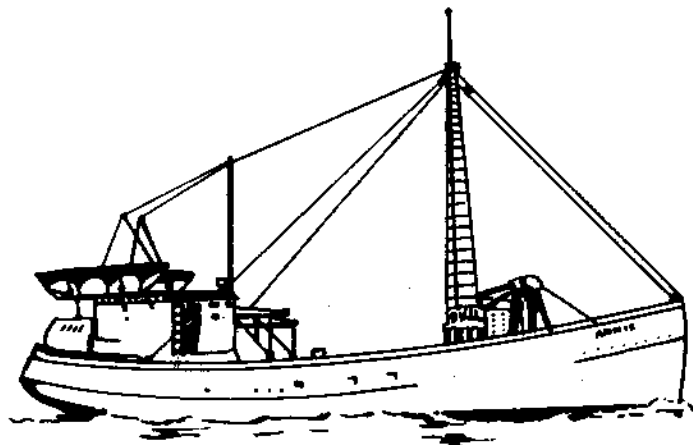

Modern Fishing Vessel

Dories are exceptionally seaworthy rowboats used in open ocean fishing. The construction of a dory gives it a deep, flat bottom, with the bow and stern curved upward. The sides are straight boards, angled on the ends to join together. Bracing inside the boat strengthens the design. A notch is cut in the stern of the dory to assist the fisherman in setting out his trawl line of baited hooks.

The use of dories allowed many crew members to set longer trawls or individual long-lines away from each other for miles around the schooner. Fishing like this increased the danger of a man being lost at sea in a fog, but it also increased the amount of catch tremendously over a wide area. Aboard a fishing schooner, dories were scrupulously cleaned out before being stacked, one inside the other, on the deck.

### Commercial Vessels Today

Most fishing vessels today are powered by gasoline or diesel engines. Probably the most familiar boat used on the Northern New England coast today is the lobster boat. Lobster boats feature long, low work areas and a tall bow to prevent water from washing over the decks and swamping the boat. Some lobster boats have a small sail over the stern which does not provide power, but keeps the boat pointed into the wind during rough weather. Most lobster boats have hulls which are widest below the waterline to help prevent rolling between waves.

Other common fishing boats in Northern New England are the herring seiners and sardine carriers which provide most of the U.S. supply of these valuable ocean foods. These powered vessels feature large, deep holds for fish, similar to the old salt bankers, and an engine room with a pilot house on deck. Many of these vessels now have cranes and machinery aboard to lighten the labor once done entirely by men. Some herring boats surround the fish with a bowl-shaped net and use a suction hose to lift them into the hold. The fish are either brought back iced in the hold or cleaned and prepared for packing on board ship.

**Otter Trawling, Also Called Drugging.** The method of otter trawling came to our country via English and Northern European influence in the early 1900's. This method of towing a net from vessel over the bottom greatly increased the efficiency with the perfection of the internal combustion engine and resulting mechanization. Otter trawling uses a large bag of meshed synthetic twine that is usually wider at its mouth than the boat towing it is long, depending on net handling and horsepower capabilities. The net then tapers back to a heavier twined bag called the cod end. This is where the fish end up as they drift and swim back along the inside of the net. The cod end is tied together at the end so when raised above the deck the fish will be emptied out by untying the pucker strings or cod end knot. The cod end usually has scrap unbraided ropes lashed to it on the bottom so as to prevent the netting from chafing through against the sea bed. At the front end of the net, there are twin netting walls that extend the sides, called the wings, of the net. These result in making the opening of the net U-shaped as it is towed over the bottom. The bottom edge of the net opening is called the sweep because it is swept over the sea floor scooping up the fish net's path. The sweep can be made of either chain for soft bottom or big heavy rollers designed to roll over rough bottom.

The upper edge of the net opening is called the head rope. The head rope is shorter when stretched out than the sweep, but overhangs the sweep when the net is towed. The head rope has many floats tied on it to help the net stay open when being towed. From the upper and lower end of the wings are cables leading to the otter boards, or doors as they are commonly called. These doors are usually five feet or longer, rectangular in shape and very heavy, weighing up to a couple of tons on large factory vessels. The doors are what keeps the net spread open by the water pressure working against their inside surface. The doors are towed by heavy cables that are winched up on board the vessel when it is time to bring the net in. The net is

towed over the bottom at about three to four knots (about four or five miles an hour) for varying lengths of time according to the area of bottom being fished.

There are two main types of vessels that are bottom trawlers. These are the Eastern or Side rig and Western or Stern trawler.

The Eastern rig dragger evolved from older converted schooners. Its main distinction is that the pilothouse is aft and the working deck is in the middle with the crew's quarters forward. This type of dragger is usually over forty feet in length.

Eastern rig vessels are siderigged in terms of their fishing gear handling. A siderigged dragger brings the net in over the side and swings the cod end in with a main boom from the mast that is placed just aft of the forecastle. The winches are usually placed in front of the pilothouse and the towing cables run through deck blocks that lead to the gallows frames.

The gallows frames are A-frame-shaped steel structures from which the doors hang. The bulk of the net is taken out over the rail so that the towing blocks hang over the water. This helps to keep the heavy doors from crashing too hard into the side. The net and doors are launched by turning the vessel slightly towards the side the net is on. After the cables have been let out to about one foot of depth, they are brought together and towed from a common point. Hauling back the net is done with the boat to leeward so that the net does not drift into the propeller.

The Western rig or Stern trawlers are the most common today, as they are generally believed to be more efficient and safer to work. The transition

from the seaworthy and time-favored eastern rig was slow until the late 1960's and early 1970's. The stern trawler has the pilothouse and crew's quarters forward and has the working deck behind the pilothouse to the stern. The gallows frames are located on each side of the stern and many vessels have stern ramps and hydraulic net reels to aid in great handling. The great is hauled up over the stern enabling the vessel to keep head to the wind which provides increased crew protection. In addition, these vessels offer greater safety by eliminating towing links. Cables are led directly from winches to towing blocks on the individual gallows frames. Also these vessels set and haul the net in a forward motion bringing the cod ends in over the stern.

**Midwater Trawling.** Midwater trawling involves a net similar to bottom trawling. However, these nets are usually constructed of decreasing net size starting with the wings of large net size down to whatever size is appropriate in the cod end for the pelagic species that are sought. They are towed in intermediate water levels depending on the depth at which schooling fish may be present. This requires more sophisticated techniques and equipment such as head rope sounders for telling how deep the net is, special trawl doors adjustable for proper spread and depth, and power enough to vary towing speed as well as net depth. With these, and with more extensive electronic fish-finding devices such as fish scopes and sonar, the experience skipper is able to combine and adjust all the factors to result in a productive catch.

### Midwater Trawling

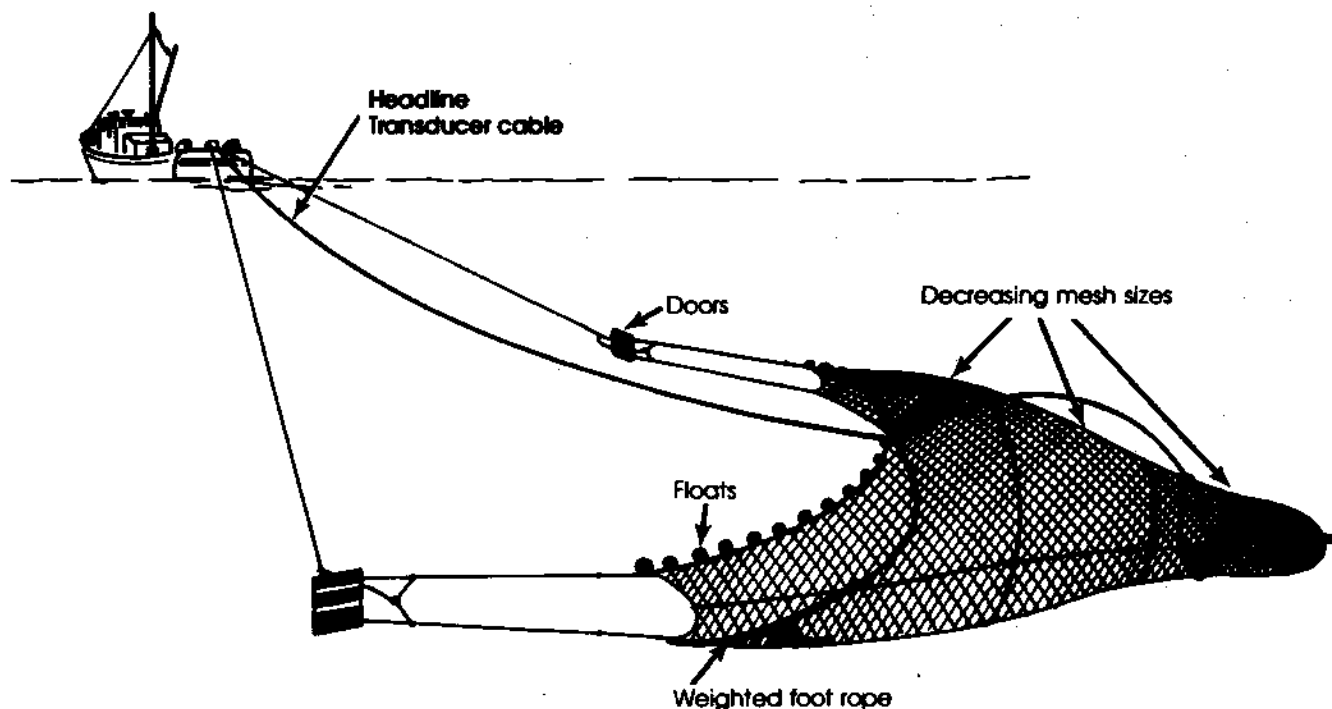



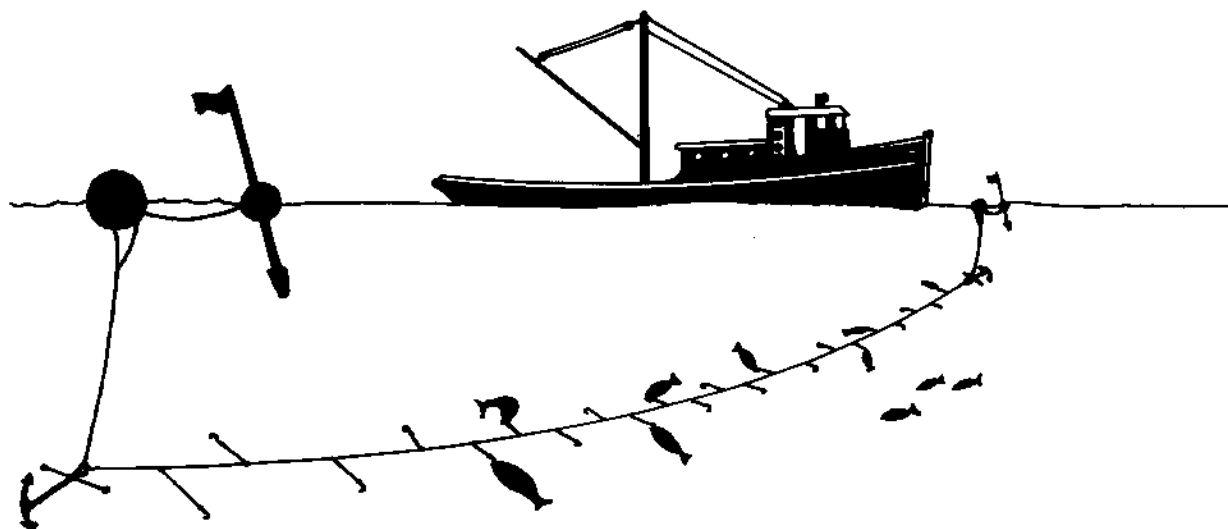

Long line set

**Longlining.** Longlining, formally called trawling, is a fishing method in which many baited hooks are connected to one long line. Recently it has been confined mostly to the halibut fishery, as draggers replaced the sailing dory. Tubtrawling is a method of longlining in which a many-hooked line is played out from a large tub. For many years up until the present, tub trawling has been used as a fill-in fishery to lobstering, especially in the spring when the halibut catch is most frequent. Tub trawling is a lot of effort for its outcome by today's standards.

In tub-trawling, the longline is usually measured out 600 feet to a tub. It then has hooks and four foot leaders attached about every six feet. Each hook has to be individually baited and the whole thing has to be coiled into a tub so that it will come out easily when set. Each end of the bottom or ground line is anchored and a buoy line is attached.

#### **Lobster Fishing, Also Called Lobstering.**

Along the Maine and New Hampshire coasts, people fish for lobster in the continental shelf waters. Although most of this fishing takes place during the spring, summer, and early fall months, some lobstermen tend traps throughout the cold winter months. The lobstermen on Monhegan Island, for example, have established a closed season for the island area. That closed season extends from July 1 to December 31, meaning that lobsters can only be caught in those exposed waters from January 1 to June 30 each year. That certainly discourages the occasional lobsterman.

Lobstermen set and tend traps from boats that range from 12' skiffs with outboard motors to hearty Jonesport and Novi boats 40' or more in length, generally powered by large V-8 gasoline engines. These fishermen and boats work anywhere from a handful of traps for the part-time lobsterman, to three hundred or more for the full-

time fisherman with a large boat and a sternman. The wooden traps, which are often home-made, are usually set out in the early to late spring after the danger of destructive winter storms has passed. These traps are lowered into the water surrounding ledges and shoals where the lobsterman feels lobsters are living. They are ballasted with rocks or concrete in which the fisherman has written his name and his license number. The trap has an opening hatch on the top which permits the lobsterman to bait and empty his trap. It has a large opening at one end which is filled with the funnel-shaped headnet. This net permits lobsters to crawl in, but not out.

The trap's position is marked by a color-coded buoy attached to the trap with pot-warp, rope usually of hemp or polypropylene. The pot-warp is kept more or less vertical in the water by a toggle buoy attached between the marker buoy and the trap. The toggle is an empty bottle or a small net float.

Before putting the trap overboard, the lobsterman baits the trap. The bait will vary depending upon the lobsterman's preferences, the season, and the availability of bait. In some places, the bait is usually placed in small net bait bags and tied into the traps. When redfish racks or carcasses are available, they can be tied into the traps with a line running through the eye sockets.

After the trap has been set for a day, or sometimes more, the lobsterman hauls the trap onto his boat. This is usually done using a winch head powered by the boat's engine, but some lobstermen with smaller boats and fewer traps haul them up by hand. Lobsters that are keepers get their claws pegged or banded with large rubber bands to prevent damaging fights in the lobster car or pound. The shorts are thrown overboard to continue growing. Female lobsters which are seeders or berried are marked and returned to the

# How a Maine Lobster Is Caught

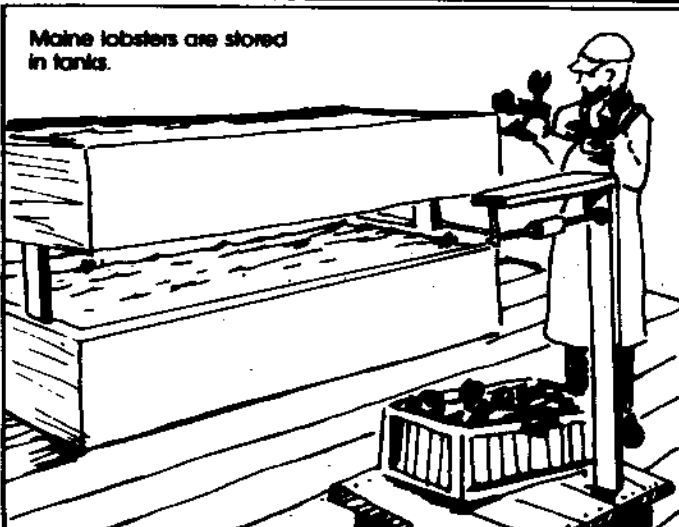
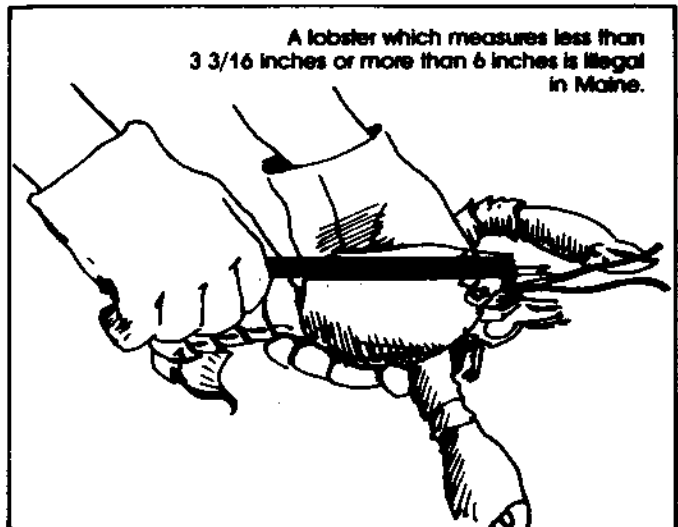
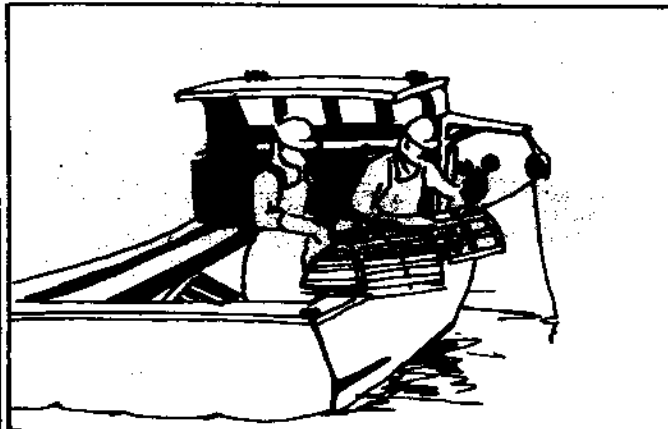
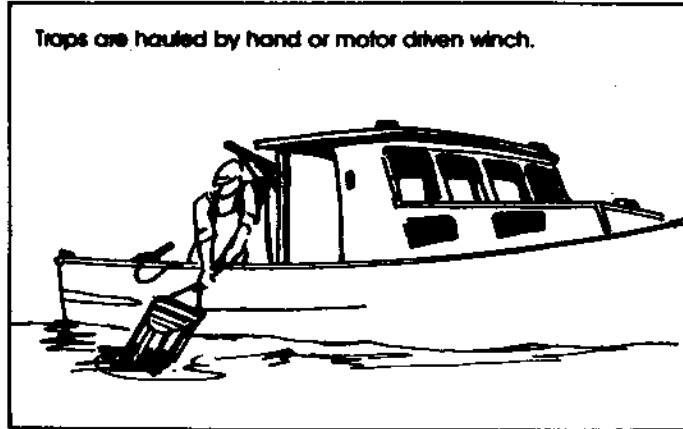
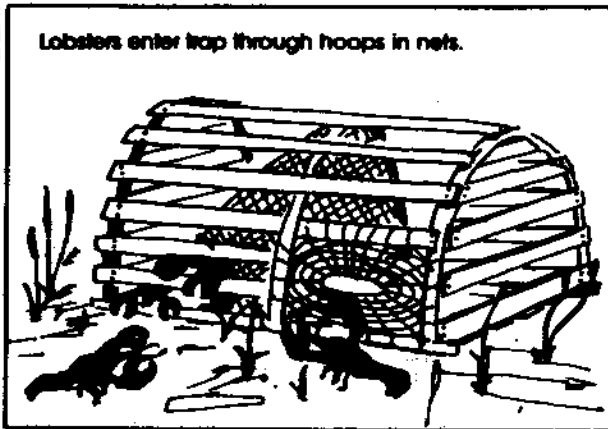
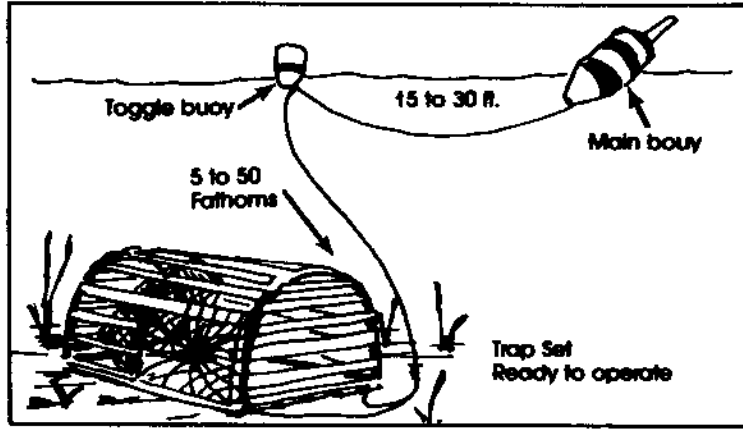
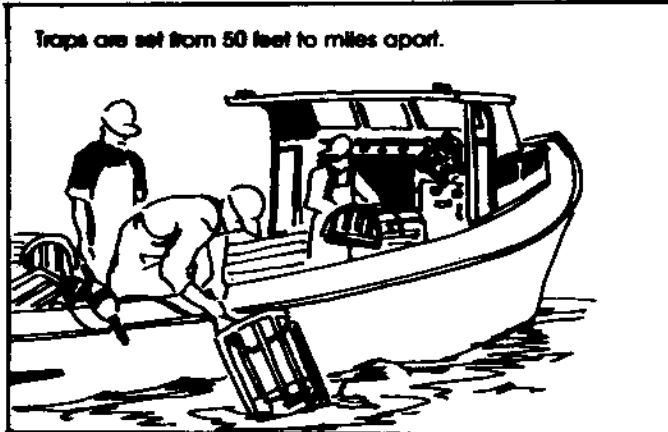
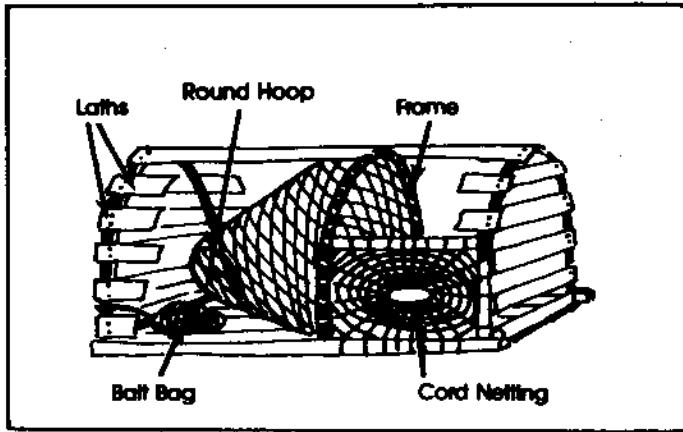

sea. These are females with eggs attached to the undersides of their abdomens. The lobsterman cuts several V-shaped notches in the tail fins of the seeder with his knife. This alerts others who may catch her that she is a productive female and that she should be thrown back. There is a fine or jail sentence as punishment for those found in possession of egg-bearing lobsters.

Crabs and urchins caught in the traps are removed and either returned to the sea or kept, depending on the available market. The lobsterman then rebaits the trap and sets it once again in the same location if he or she is happy with its production, or elsewhere if not.

With fall and the increasing risk of severe storms, which dash traps against the rocks or wash them to sea, the lobsterman hauls traps and takes them ashore for repair and winter storage.

Katahdin

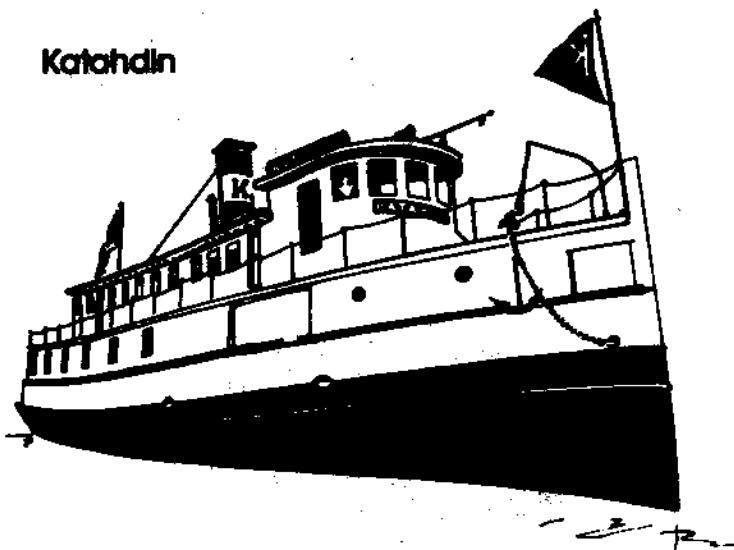

## Coastal and Lake Steamers

Luxurious steamboats once operated from New Hampshire and Maine to Boston and New York carrying freight, mail, and tourists quickly and conveniently along the coast. Similarly, somewhat smaller vessels plied the lakes of the region. Of those, two remain; the *Mt. Washington* on Lake Winnepesaukee, New Hampshire and *Katahdin (Kate)* on Moosehead Lake, Maine. *Kate* is currently docked, but is slated to be restored and will again ply the waters of Moosehead. The *M.V. Mt. Washington* is currently in service as an excursion vessel. This boat is not longer steampowered but it looks the part.

Steamers were named after coastal towns, famous New England personalities, or geographical features. Steamboats were powered either with propellers or paddle wheels. On paddle wheel ships, steam cylinders were linked to the wheel by a lever and two long bars called a walking beam. When the engine was in motion, the walking beam appeared to be stepping up and down on the ship's deck like a pair of legs. Propeller driven ships did not have walking beams as all the machinery was contained within the hull.

Coastal steamboats were usually painted white and gold with elegant wood carvings on the superstructures and in the public rooms inside. They had several decks on top of each other to facilitate observation and many cabins lined the railings. Inside, there were dining rooms and large ballrooms. The pilothouse was situated on the hurricane deck. Too often, sparks from the engines would set the wooden superstructures ablaze and people would be killed. Many steamships ended their careers in this unfortunate fashion. The coastal steamers began to fade away as the automobile became popular and roads improved. The last New England Coastal steamers stopped running on the eve of World War II. They never came back into use after the war.

# Classroom Activities

## The Parts of a Vessel

A good introduction to boats should include a physical introduction to the parts of the vessel and nautical names for directions involved when one is on a boat. This can be done with reference to the canoe diagram. For reality, an actual canoe or small row boat could be used in front of the classroom for physical location of parts and directions. Alternatively, a hull top view could be applied to the floor with colored tape. Students can be given copies of the canoe diagram as well as the nautical terms list. This is a good opener for the unit.

Acting out directions by having the teacher or selected students ask student participants go to the port side, go aft, locate the bow, gunwale, and so on is better than pictorial identification.

### Ship Terminology:

**aft:** rear direction on ship

**beam:** breadth of ship

**boom:** lowest wooden beam used in schooner rigging

**bow:** foremost part of ship

**bowsprit:** boom extending from bow of vessel

**capstan:** upright revolving drum used to lift weight

**cutwater:** where ship's bow meets water

**davits:** small cranes from which lifeboats hang

**deck:** floorlike platform of a ship

**fathom:** unit of length equaling six feet

**forecastle:** storage area in bow of vessel

**freeboard:** amount of hull between deck and waterline

**galley:** kitchen area

**halyard:** a rope for hoisting and lowering sails

**hold:** interior of ship below decks

**hull:** frame or body of a ship

**keel:** midline of ship upon which ribs are fastened

**knot:** unit of speed equaling 1.1 land miles per hour

**leeward:** side of vessel away from the wind

**mast (fore, main, mizzen):** upright poles from which sails hang

**navigate:** to steer or direct the course of a ship

**oar:** long rowing paddle for propelling small craft

**port:** directional — left

**sheer:** horizontal curvatures of a ship's deck

**spar:** crosspiece from which sails hang on masts

**starboard:** directional — right

**stem:** cutwater edge of bow from bowsprit to keel

**stern:** rearmost portion of vessel

**windward:** side of vessel the wind is hitting

**yard:** another name for spar — crosspiece from which sails hang on mast

## Keeping Afloat

Most students do not expect that they can make boats from materials which do not float. This frequent logical discrepancy is a good place to start teaching about buoyancy.

You will need small pails with several centimeters depth of water and a few sticks of oil-based modeling clay for this class activity. Each working pair should have a pail, water and two ball shaped pieces of clay each about three centimeters in diameter.

Have each pair fashion a "canoe hull" from one of their balls of clay leaving the other in ball form. Next place each piece of clay, the ball and the boat, gently into the water. Observe the result. Note that not all boats will float. Some students may need a few minutes to reshape their hulls. Discussion on why some are successful and others are not successful is a useful catalyst.

Finally, measure the load capacity of vessels using uniform objects as cargo. Small paperclips or other similar sinkable objects work well. This activity can be extended into a boat design contest with prizes given to the designer who produces the hull with the greatest "deadweight paperclipage."

Introduction of theoretical information on buoyancy, tonnage, and other concepts follows nicely after this introductory float/sink experience.

## A Paper Boat

Boatbuilding can be introduced to students by having them build cardboard half-models of the Whitehall rowing boat. This can be done very simply using poster board for a background and heavy cardboard for the body members. Reproduce copies of "The Lines Plan" and "The Body Plan" for each student. The project is begun by using paper glue to apply the student's copy of the Lines Plan — profile view to the center of an 8½" x 11" piece of stiff poster paper. The next step involves making cardboard cut outs of the Body Plan, sections 1 through 6.

Body Plan sections are glued on to the positions on the Lines Plan to which they correspond. The

flat side of each Body Plan section is glued over the line designating the station position, being careful to keep the same end upright as in the Body Plan. If desired, masking tape may be applied over this half model "frame" to simulate planking. The framework model alone, however, better shows how lofting relates to a finished boat.

Interested students may wish to turn their paper models into wood models as a homework project. The procedure described can be used with lines diagrams obtained from a variety of sources such as *Wooden Boat* magazine, *Commercial Fisheries News*, the *National Fisherman Newspaper* or designs purchased from marine designers. Advertisements for boat designs are contained in the publications mentioned above.

## Fan Sailing

The best way to learn how a wind and sail move a vessel is directly by real sailing experience. This may be impossible for your class and yet they can get some vicarious experience with sailing rigs by making small model boats with single-square or fore-and-aft sails.

Clay hulls with toothpick masts will get them started. A large sink or tray of water and a well-insulated table model electric fan with ample blade guards are needed. Fans that blow in one constant direction are preferred.

The first major task is to make hulls with enough keel so they do not capsize immediately. After vessels are made which keep upright, group contests can be organized where designs are entered in competition with others.

Discussions on the advantages of various sail designs — both fore-and-aft and square — as well as mast locations and hull shapes should be encouraged after races are conducted.

A cooperative school industrial arts teacher may help class members make wooden rather than clay hulls for more permanence. In any case, boats should be made small to allow several to be used at once.

## Sail-O: The Game of Sailing

This game is designed to simulate the decisions necessary to cause a sailing craft to follow a preselected course. The game is played on a playing board made out of a grid consisting of squares each 2 cm by 2 cm. Playing pieces can be small boat models or handy colored objects.

In the simplest form, the grid system is attached to a rigid backing about 1 meter square with directions noted as north, south, east and west on the edges. For a shortened game a checkerboard can be substituted. Wind direction is selected by drawing from a set of cards with letters for each of the four major directions. Wind direction remains constant throughout the game. A large arrow made

## Paper boat model of a Whitehall boat

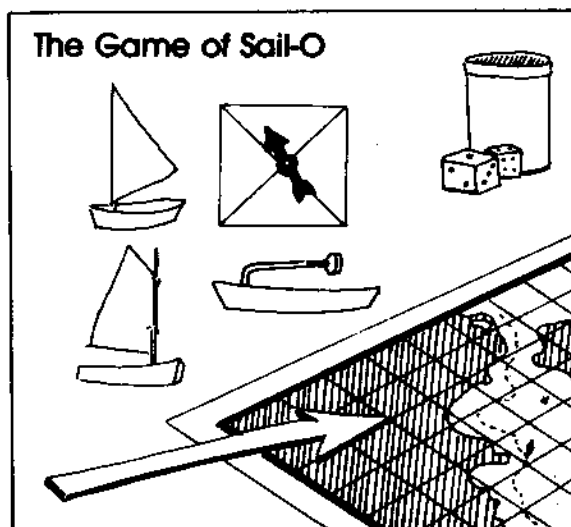
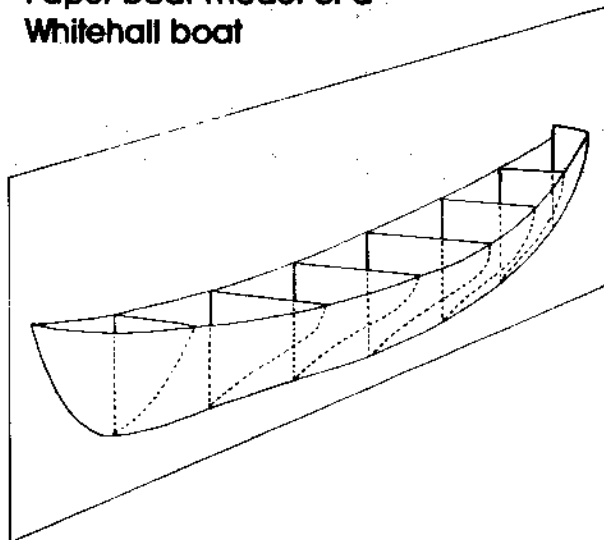

of cardboard is placed on the edge of the board to indicate wind direction.

Play starts from the lower left corner of the board over a course leading to the upper right corner. Each player in turn throws the die or flips the spinner to determine the number of squares he/she moves. Plays may move in any direction desired except directly into the wind. Moves diagonally to windward (45°) are allowed.

You may want to leave your discussion of tacking until after one play of this game, as by then your class will have discovered it by themselves.

The game can be made fancier by making your grid system with a magic marker directly on a nautical chart. You might select: 13327—Grand Manan Channel, 13313—Isle au Haut, 13305—Penobscot Bay, 13290—Casco Bay, 13282—Portsmouth. Charts suppliers will be listed in the resource section. When you use an actual chart, boats must keep outside of some arbitrarily determined depth such as 6 feet.

\* This game is adapted from: Lane, C.D. *How to Sail*. New York: W.W. Norton, 1947.

An additional complication could be to require playing pieces to be model boats made perhaps from soap with a toothpick mast and fore-and-aft sail. Players would then be required to haul their sails around when tacking. This makes the simulation more realistic.

## Block and Tackle

A sailing vessel depended upon a number of simple machines, especially the pulley which navigators called blocks. Small pulleys can be obtained from science kits or from the local hardware store. A variety of block and tackle arrangements can be set up with three pulleys and a length of stout cord such as that used in macrame. A known weight is placed at the end of the tackle and then weights are added to the pulling side of the tackle until the weight to be moved just rises slightly. The value of the weight lifted divided by the lifting weights is the mechanical advantage of the arrangement. This is also usually the same as the number of support strings.

## Chanties: Singing and Work

Sea chanties were sung to help get work done. Generally, they abounded on sailing vessels where muscles were the only reliable source of power for getting work accomplished. Sea chanties never were sung aboard military or naval vessels.

There are two types of sea chanties. One is a capstan chanty used by men circling a rotary capstan which was used to raise anchors. One of the most famous capstan chanty is "Rio Grande." A second type of chanty was used when pulling lines attached to blocks which moves sails and pieces of rigging. A hauling song often had the word "HAUL!" at the end to coordinate the pull of perhaps a dozen men holding the end of a line.

The purpose of a sea chanty was to organize the labor needed to perform a group task into one concerted effort. One man, presumably the one who knew the most verses, called the chantyman, was assigned to sing the lead-in, while everyone joined in the choruses. All sailors took part in this because it didn't require any vocal skill other than to repeat a chorus and pull for all they were worth.

Chanties tend to be slow and paced with the speed of the backbreaking labor. Sailors also often tended to show up on board the first day out with miserable hangovers or recovering from a fight in port. As a result, sea chanties ramble and are dischordant. For instance the three lines in the verse of "Rio Grande" should require at least 15 seconds to repeat assuming the sailors are bent over a capstan, walking in a circle, and raising a fifteen hundred pound anchor. In the two

traditional songs provided, affected pronunciation is used. In the first "Rio Grande" is pronounced "Rhye-O-Grand." In the second song "The Bowline" is pronounced "Bo-lin."

A good class follow-up to merely singing these songs is to play them out. A capstan chanty should be sung while walking slowly in a circle. Only one chorus is provided so the class can write their own subsequent choruses to tell the story of a sailor from Northern New England who leaves Portsmouth, N.H. for Rio Grande do Sul in Brazil. Using an atlas for place, names can add another dimension to the writing.

In the second song, the singers should be pulling a rope. New solo verses can be added in which various people such as the captain are referred to in humorous ways instead of the phrase "the fore and maintop bowlin'."

## Old Ironsides

Frigates were fast naval vessels of the late 18th and early 19th centuries. These ships had lofty sails and one or two decks of cannon. The U.S.S. *Constitution*, also known as *Old Ironsides*, is a frigate built in 1797 to defend U.S. merchant vessels in the Mediterranean from pirate attacks. This vessel won her fame in the War of 1812, when she engaged the British frigate *H.M.S. Java* of South America and destroyed it. A British sailor watching his ship's cannonballs bounce off the *Constitution* remarked that the ship's sides must be made of iron, which they were not.

Today, the *Constitution* is on display in the Boston Charlestown Naval Shipyard and may be boarded for inspection. A similar U.S. Frigate, the U.S.S. *Constellation*, is on display in Baltimore Harbor.

As an activity, have the class read Oliver Wendall Holmes' poem "Old Ironsides," written when the ship was in danger of being scrapped.

The frigate *Constitution* was not saved by the government because of sentimental value. In 1830, the Navy wished to retire the vessel and break it up for salvage. Many Americans became outraged, including a law student named Oliver Wendall Holmes, who wrote this poem arousing popular sentiment for the frigate's preservation.

The ship was not broken up but was converted into living quarters for sailors and in 1931 was rebuilt as the original frigate with money from penny contributions of school children.

### Old Ironsides

Aye, tear her tattered ensign down!  
Long has it waved on high,  
And many an eye has danced to see  
That banner in the sky;  
Beneath it rung the battle shout,  
And burst the cannon's roar; —  
The meteor of the ocean air  
Shall sweep the clouds no more!

Her deck, once red with heroes' blood,  
Where knelt the vanquished foe,  
When winds were hurrying o'er the flood  
And waves were white below,  
No more shall feel the victor's tread,  
Or know the conquered knee; —  
The harpies of the shore shall pluck  
The eagle of the sea!

O better that her shattered hulk  
Should sink beneath the wave;  
Her thunders shake the mighty deep,  
And there should be her grave;  
Nail to the mast her holy flag,  
Set every threadbare sail,  
And give her to the god of storms —  
The lightning and the gale!

by Oliver Wendall Holmes

## Making Scrimshaw

Since whales are protected by U.S. law, new whalebone and whale products are not permitted into the country. Youngsters may make some similar scrimshaw items by the following process:

- Thoroughly wash and clean smooth beef bones — ribs are good.
- Soak the bone in chlorine bleach for a half hour to bleach and disinfect it. Rinse it off.
- After the bone dries, lightly sand it with fine sandpaper in the direction of the grain.
- With a pencil, sketch a nautical scene on the bone.
- Using an artist's scribe or a sharpened nail, scratch the desired image onto the surface of the bone. Wear safety goggles and one glove for protection during this procedure.
- Rub over the scratched image with India ink to color in the lines. The black should wipe off the unscratched surface of the bone.

An alternative method also useful is to substitute plaster of paris pieces for beef bones.

## Live on a Coaster

Win Kelley also provided us with his recollections of life on a schooner. His words are reproduced here for class reading. A good follow-up exercise is to have class members write a short play to act out the life of the schooner man.

### Life Aboard Sailing Vessels During the Early 1900's

by Win Kelley

Living conditions aboard the sailing vessels had improved greatly over those of the 1800's. The smaller schooners still relied on kerosene for lighting purposes, while the larger four and five-masted schooners had generators installed for providing electricity. Coal and wood stoves were used for cooking and heating, while in the larger schooners, it was not uncommon to find steam heat used for living quarters.

Following are incidents that might occur in the everyday life on board a coastwise schooner:

Meals were always served on time when a full-time cook was in the crew. While in port, after breakfast, the crew turned immediately to proceed with the work of the day. This depended upon whether discharging cargo at a lumber dock or destination, or if awaiting a chance to proceed on a voyage, or unloading at a port where the work was being done by stevedores, or longshoremen.

If the crew was involved in discharging cargo that meant working an eight or nine hour day, otherwise they were involved in general maintenance on the ship. This was a never-ending task and including scraping paint, sanding, and painting; scraping and slushing down the spars; working on the rigging, including serving, parcelling, and splicing; tarring the shrouds that supported the masts; replacing ratlines when and where necessary; and scraping and tarring decks at least once a year. If the weather was bad, and space was available below decks, the crew might become involved in making chafing gear, sometimes called baggy wrinkle, or splicing rope that could be used for utility purposes on board the vessel. There was always something to be done, and it was only on rare occasions that a crew member had nothing to do but to turn in in his bunk.

When the ship was underway, things were different. The crew was divided into two watches, or groups. One was the Captain's watch, called the starboard watch, the other was the Mate's watch and was called the port watch. The watches were equally divided among the crew members. In the larger schooners having a full-time cook, he was the only crew member who was not required to

stand watch. His duties usually required the greater part of the day in preparing meals for the crew. He had additional duties of taking care of the running lights, and usually relieved the man at the wheel in order that he might go below and eat with the other crew members when the meals were being served. If the crew contained a second mate, or bosun, he was usually included in the Captain's watch to permit the Captain to go below, especially if weather conditions were favorable.

The services of the entire crew were necessary when getting the vessel underway. First of all, sail gaskets had to be removed, the slack of the anchor chain had to be taken in. The method used depended upon the machinery available on the craft. In the early days of sail, there was no power available for this work; weighing the anchor and hoisting the sails had to be done by manpower. The anchor was raised by a device called a capstan or windlass. The sails were raised by the use of blocks and tackles, and it was a long and tedious job in getting a schooner underway with a small crew. Later the introduction of the stationary gasoline engine enabled this work to be done by mechanical methods, sometimes resulting in the vessel carrying a smaller crew. After the anchor had been raised and all sails were set, including topsails and jibs, the halliards had to be coiled, and the deck area had to be arranged in a satisfactory manner in order that all lines would readily be accessible in case of emergency. At all times, the crew members had to practice extreme caution in order to avoid accidents to themselves or to their fellow crewmembers. In loft work and on the jibboom, the slogan "one hand for yourself and one for the ship" had to be observed at all times. Finally, when the craft was well on its way, the watches were set and continued until the vessel reached its destination or put into a harbor of refuge to avoid stormy weather conditions.

The watch on deck was responsible for sailing the ship, keeping the craft on its proper course and correct point of sailing, keeping a good lookout especially at night or during foggy weather when it was necessary to sound the fog horn at periodic intervals, and making sure that the bilges were kept as free of water as possible. Before the days of the gasoline engine, pumping ship was a back-breaking task, and was one that had to be done during every watch on deck. What would require less than five minutes by motor would require an hour of pumping by hand. In some cases, when a ship was leaking badly, the pumps had to be operated constantly. The watches were four hours in length. To explain their spacing, let's begin at 8:00 p.m., called

ending at 12:00 midnight — again called eight bells. Other bells for this period are as follows:

8:30	1 Bell
9:00	2 Bells
9:30	3 Bells
10:00	4 Bells
10:30	5 Bells
11:00	6 Bells
11:30	7 Bells
12:00	8 Bells

The next watch lasted from 12:00 midnight to 4:00 a.m., the next from 4:00 a.m. to 8:00 a.m., then from 8:00 a.m. to 12:00 noon, from 12:00 noon to 4:00 p.m. The time between 4:00 to 8:00 p.m. was divided into two, two hour watches, called dog watches, one from 4:00 to 6:00 p.m. and the other from 6:00 to 8:00 p.m. These watches kept the crew from standing watch during the same hours each day. Usually during good weather, the crewmen off watch were required to spend a few hours of the afternoon below doing any necessary work on the deck that might be required to keep the vessel in shipshape condition. Thus it can be seen that the crew spent a minimum of twelve hours each day on duty, as well as a few more hours during good weather, and were always on call to assist in shortening, or making sail, whenever the condition required their services.

Meals were served prior to the end of the watch on deck at 8:00 a.m. and 12:00 noon, and during the latter part of the 4:00 to 6:00 p.m. watch. Meals were prepared in the galley of the vessel, but the location of the galley differed in ships according to the size of the craft. In the small two-masted schooners, the galley was located on the forward part of the main cabin on the after part of the ship. Likewise, the crew's quarters were located in the main cabin, and all crew members, excepting the cook, ate at the same time. In the larger schooners, the seamen ate their meals in the fiddle or forecabin. The galley was also located in that cabin, as well as the donkey engine that was located in the forward part of the forward cabin. The captain and mate of the large schooners ate their meals in the after cabin. This more or less resulted in a class distinction on board, but as it had been done traditionally, no thought was given to this practice.

The food served to the crew was substantial and its preparation and taste depended upon the qualifications of the cook. Some cooks prided themselves upon how cheaply they could feed a crew of seamen, and others made an honest effort to prepare meals that were tasty and filling. Needless to say, the first category of cooks pleased the



owners, while the second type pleased the crew. The small coasters had no refrigeration, therefore fresh foods were not available, except when purchased in ports. A bountiful supply of canned goods was always on hand; as were plenty of potatoes, salt pork, dried salt fish and in some cases, a barrel of corned beef. Baked beans were served twice weekly on Wednesday and Saturday. Salt fish dinners were served on Tuesday and Friday, and fish hash was served nearly every day with the evening meal. Canned and dried fruit were plentiful, as well as pilot crackers called hardtack. Some cooks prided themselves on their ability to prepare special foods such as yeast bread and fancy pastries, while others resorted to the old staple foods, such as biscuits, molasses cakes, and cookies. There was no need to go hungry, as the crew was always permitted to raid the galley during the long night watches.

The after cabins on the large schooners were usually elaborately finished in mahogany or some other hard wood, and were most attractive in appearance. The forward cabins occupied by the seamen were not so attractively finished; however, they were adequate for the most part. Toilet facilities in most of the small vessels were most spartan. The bathroom, or flush closet, was non-existent. Instead a bucket and rope were placed under the forecabin head for use when necessary. Flush toilets were found in the after cabin for use by the ship's officers.

Fresh water was a problem on many of the schooners. In most vessels, it was kept in wooden barrels, or casks, and was not always of the best quality. As freshwater was not readily available at most of the loading docks, it was a difficult task to fill the containers, and in many cases the quality of the water was such that it could be used only after it had been boiled, or in tea or coffee. It was a great treat to get the water casks filled with fresh water when in a port such as New York or Boston.

## Reading Captains Courageous by Rudyard Kipling

This novel is based on a way of life which is only recently extinct in New England. Harvey Cheyne is a millionaire's bratty son who falls overboard from a transatlantic liner amongst a fishing fleet. He is rescued by Manuel, a dory fisherman who brings him aboard the schooner *We're Here*. Harvey pleads, threatens, and tantrums to impress the crew with his importance. The men remain nonplussed, and put Harvey to work as a member of the crew, teaching him the art of fishing and the

business of earning a living on the Grand Banks. Over the course of the summer, profound changes in Harvey's life created a new, mature young man.

A deeper relationship seemed to have existed between working men and the sea during the time of this novel, a partnership of sorts. Hopefully, in the course of reading this book, youngsters will become aware of this aspect of the heritage of Northern New England and Atlantic Canada, and may direct their interests toward the fisheries again. Two motion picture versions of this story have been made, neither being faithful to Kipling's story in ending or characterization.

### Chapter Questions for Captains Courageous

#### Chapter I

1. How did Harvey try to impress the men on board the liner?
2. What circumstances led to his arrival aboard the *We're Here*?
3. How did Disko respond to Harvey's offers and tantrums?
4. What was Harvey missing from his pocket?

#### Chapter II

1. How does Dan evaluate Harvey and his behavior?
2. What does Harvey do with Disko after talking to Dan?
3. Describe how Harvey spends his first night aboard ship.
4. How is codfish dressed down?

#### Chapter III

1. Why did Disko move the schooner?
2. What type and size fish did Harvey catch on his line?
3. What was Penn's background before becoming a fisherman?
4. How did Long Jack teach Harvey the ropes? Why?

#### Chapter IV

1. What kinds of offerings did the men give for protection on the waters?
2. What kinds of musical instruments were found aboard ship? Why?
3. Why did Disko take exception to Skipper Ireson's ride?
4. What was the cook's prediction?
5. What is a Jonah?
6. Name two contributing factors in the loss of Abishai's boat.

#### Chapter V

1. What did Harvey tell the crew members for entertainment?
2. How does flying the blue pigeon work?
3. In what kind of shipboard work did Harvey do well?
4. What was the Virgin?

## Chapter VI

1. What did Disko trade with the cattleboat?
2. What was the *Carrie Pittman's* problem?

## Chapter VII

1. How did death come out of the fog?
2. How did Harvey and Dan attempt to protect their schooner?
3. What became of the *Jennie Cushman*?
4. How did Penn work his miracle?

## Chapter VIII

1. Why did the fishermen call the Virgin Rocks "in town?"
2. What tangled in the dory anchors and pulled the boats along?
3. Why did Harvey prize the dead Frenchman's knife?
4. What did Harvey catch on his line, and how did he deal with it?
5. How did the cook protect the *We're Here* from ghosts?
6. When Disko left the Grand Banks for home, what services did he perform for the other fishermen?

## Chapter IX

1. How did the Cheynes learn Harvey was alive?
2. What arrangements were made to get the Cheynes to Boston?
3. What changes did Harvey's father notice in him?
4. How did Uncle Salters change his opinions about the boys?
5. How did Disko react to Harvey's social status?
6. What offer did Mr. Cheyne make to Disko and his wife?

## Chapter X

1. Why was going to college important to Harvey's future?
2. Where did Harvey stand during the town ceremony?
3. What was the ritual performed every year at the town ceremony?
4. What became of the cook's prediction years later?

Following the fish was an art for which Disko Troop was widely recognized by his peers. Kipling says that while Disko thought about the cod he even began to look like one.

In order to determine if the schooner was over fishing grounds, Long Jack would "fly the blue pigeon", toss a lead weight with a hollow in it filled with grease. When the lead was retrieved, whatever was on the bottom would be stuck in the grease, either sand, rock or weeds.

1. Using the Atlantic Coast Chart #13003 (Cape Sable to Cape Hatteras) and Chart #14017 (the Grand Banks), locate: Gloucester, New York, Georges Bank, Nantucket Island, LeHave Bank, Halifax, Lunenburg, Banquero

(Bank Quero), the Grand Banks, the Virgin Rocks.

2. Chart the progress of the *We're Here* across the fishing grounds as you read the book. Determine the probable area of Harvey's fall from the liner.

## Model Lobsterboat Hull Construction

Cut out the keel and stations patterns included in the pocket. Tape the two pieces of the keel together to form one smooth template. Now, carefully trace the patterns on balsa wood approximately 1/8" thick. Using an exacto type knife, carefully cut out each of the sections and the keel. Number each section as you cut it out, and draw the waterline (LWL) on each section using a straightedge. Draw the waterline on the keel as it is drawn on the pattern. Mark the station positions and numbers as they appear on the keel pattern onto the new balsa keel.

Next, cut a notch the thickness of the balsa wood in each of the sections from the bottom center up to the waterline. Note that section 0 has no waterline on it, since when the hull is afloat, that section should just touch the water. Cut a notch in section 0 about 1" deep and a similar depth notch in the keel at station 0. Insure that the tip of section 0 just touches the waterline on the keel.

At each of the other stations on the keel, cut a notch the thickness of the balsa down from the top of the keel to the waterline (LWL). Notice that there is no station T to correspond to section T. That is because T is the transom. Using white glue, glue it to the after end of the keel with the section bottom flush with the bottom of the keel section which is above the propeller cut-out. Insure that the waterline on the transom intersects the waterline on the keel.

Now, apply white glue liberally to the notches in each section and to the notches in the keel and put the sections into the keel. Be sure to keep the sections perpendicular to the keel as the glue sets. Make sure that the waterline on each section intersects the waterline on the keel as you put them together. Set this "backbone" and "ribs" aside to dry.

This process you have just gone through is not dissimilar to the manner in which boatbuilders actually construct framed boats. Of course, their sections are hollow ribs rather than our solid sections, and their keel is not nearly as deep as ours inside the boat, but the technique is similar.

When your frame has dried, the hull is ready to be planked. You, or your students, can see the shape of a real lobster boat hull by covering this frame. Strips of masking tape, or paper mache can

be used to plank your hull. Turn it keel up and apply the planking.

The hull you have just completed will show your students the shape of the hull of many of today's active lobster boats. This model is actually of the Downeast 40, whose lines and profile are included in your unit courtesy of Webber's Cove Boat Yard, Inc., in East Blue Hill, Maine.

You'll notice that your sections have the shapes of the half-sections drawn in the body view in the middle of the lines drawing page, and that the profile of your keel comes from the profile drawing at the top of the page. Planking your hull will show the various contours depicted in the half-breadth drawing at the bottom of the lines drawing. Try making a balsa cradle to display your hull, or hang it from the ceiling.

## Building A Model Walking Beam Engine

Share the picture of the coastal steamer *State of Maine* with the class. Point out the walking beam's structure. Using the enclosed outline and the assembling instructions, students can build a two dimensional functioning model of this engine. Stiff cardboard, white glue, scissors and paper fasteners are all the supplies needed.

## Gathering Local Information

In this unit, information has been presented on a limited number of vessels, especially the sailing schooners of the late nineteenth century. Many other types of sailing and steam craft shaped the history of this region. A class project is a very appropriate choice to round out your study of our maritime heritage. Groups of students can select to explore boats available as photographs or in paintings or even as full size displays in the museums at the end of the unit.

Project reports might include written information collected during class trip. Also, photographs taken of displays and interview information is provided by museum guides.

Some additional vessel types not previously mentioned are:

- canal boats
- gundalows
- Rangeley Lakes rowing boats
- canoes
- bateaus
- cat boats
- lumber rafts
- pea pods
- river fishing boats

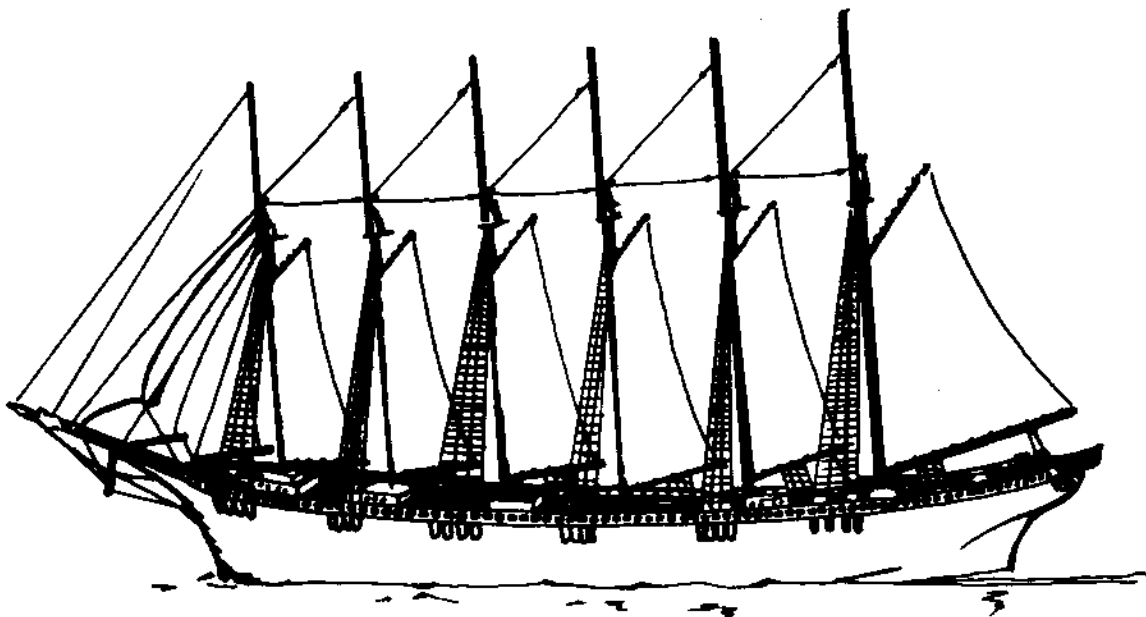

# Teacher Resources

## Annotated Filmography

**Marine Fisheries.** This is a series of six color filmstrips and cassette tapes developed by the Marine Advisory Service. Of special note are: "Gill Netter's Day", "The Lobsterman", "On Board a Trawler". The complete set is available for purchase from Maine Sea Grant Publications, Coburn Hall, University of Maine, Orono, Maine 04469.

## Annotated Bibliography

Many hundreds of books and articles have been published on the topic of boats and other craft. A few were selected for listing in this guide. Many good libraries in the region have extensive collection of sea literature from which students may select ideas for further research.

## Bibliographies:

**Marine Books and Prints.** Published as a supplement to *National Fisherman*. This is an extremely valuable listing of regionally published books, pamphlets, prints and photographs — a library in itself. This bibliography is updated periodically. Available from International Marine Publishing Company, Camden, Maine 04843.

**Maine Shipbuilding: A Bibliographical Guide** compiled by William Baker. A twenty-two page pamphlet providing bibliographical notes and annotation on a wide variety of sources particularly older and scholarly works. Published in 1977 by the Maine Historical Society, Portland, Maine.

**Marine Resources: Print and Non-Print.** A bibliography, film list and resources description developed in 1977 by the Department of Educational and Cultural Services, Augusta, Maine 04333. Available for purchase through the State Library.

**The Wooden Boat Index (Issues 1-3).** An index of articles from the beginning through 1980 of *Wooden Boat Magazine*, an invaluable resource for locating articles on special vessel types from canoes to Whitehalls. Published in 1980 by Wooden Boat Publications, Naskeag Road, Brooklin, Maine 04616.

**Books from Maine.** Distributed by the Maine Writers and Publishers Alliance, P.O. Box 143, So. Harpswell, Maine 04079. It is an occasional publication of the Maine Writers and Publishers Alliance. It lists more recently published material by and about northern New England.

## Selected References and Resources

### Canoes and Native Boats

Adney, E.T., and Chapelle, H.I. *The Bark Canoes and Skin Boats of North America*. Washington, D.C.: The Smithsonian Institute, 1964. This is a book for the scholar; it contains copious research notes on building methods and line drawings by Adney.

Fichter, George S. *How to Build an Indian Canoe*. New York: David McKay Co., 1977. This is an easy-to-read book which gives many interesting details for the non-technical teacher.

### Boat Building

Brewer, E.S. and Betts, J. *Understanding Boat Design*. Camden, Maine: International Marine Publishing Company, 1980. Contains much information about boat shapes, styles, and construction techniques. Great detail is given to sections on lines diagrams.

*Wooden Boat Magazine* is published bimonthly at P.O. Box 79, Brooklin, Maine 04616. This publication provides information on all aspects of current and historic boats, building techniques, finishes and contains advertisements which will help locate catalogs of boat designs. These catalogues often contain scale lines drawings similar in size to diagrams in this guide, for example: Design Posters, Jay R. Benford, Box 399(A), Friday Harbor, WA 89250 (from the "Plans and Kits Section," December, 1980, p. 140).

Apprenticeship of the Maine Maritime Museum. *Half-Hull Modeling*. Bath, Maine: The Apprenticeship, 1980. This new edition of the 1976 *Half Modeling* is a good teaching resource. A detailed, well-illustrated book of directions and templates to construct a half model of a Muscongus Bay Sloop, it also provides an excellent overview of boat building. The writing is sensitive and clear; the graphics are excellent. The Apprenticeship is dedicated to quality and we confidently recommend their publications or a visit, if possible. Write to the Apprenticeship, Maine Maritime Museum, 375 Front Street, Bath, Maine 04530 for details.

Weire, H. *Ship Models and How to Build Them*. New York: Thomas Y. Crowell Company, 1973. This is a general but practical book on the topic. Provides numerous examples.

### Whitehall Rowing Boat

The Whitehall is part of the training course at the Marine Trades Center, Eastport, Maine. Contact person: Otto ("Junior") Miller, the school's director. First year students at the center build Whitehalls and second year students build Buzzards Bay Sail Boats as their practical projects. A visit of MTC is an excellent career education experience and will provide the opportunity to see molds in use. A detailed article on building a 14' Whitehall is Southwart, W.C., *Wooden Boat* no. 5, page 12. "An Amateur Built Boat."

### History of Boat Building

This bibliography would be incomplete without special reference to the "greatest" historian of sail, Howard I. Chapelle. For an article on him see Gillmer, T.C., *Wooden Boat* no. 5, the lead article. Below is listed a partial bibliography of Chapelle's works which are

available in many libraries including at the University of Maine at Orono Fogler Library, the Cole Marine Collection. Chapelle's works are distinctive in that they are extensively illustrated with line drawings from which models could be built.

Chapelle, Howard I.

- The History of American Sailing Ships, 1935.**
- American Sailing Craft, 1936.**
- The History of the American Sailing Navy, 1949.**
- American Small Sailing Craft, 1951.**
- The National Watercraft Collection, 1960.**
- The American Fishing Schooners, 1825-1935, 1973.**

### **Square Riggers**

A set of study materials including photographs, diagrams and display materials on clipper ships entitled **Clipper Ships and the Cutty Sark** is available as Jackdar's set No. 97.

Order from:

Grossman Publishers  
44 West 56th Street  
New York, NY 10019

A unique book giving a great detail about life aboard a square-rigged merchant ship is **Captain Irving Johnson's The Peking Battles Cape Horn, 1977**, National Maritime Historical Society, 2 Fulton Street, Brooklyn, NY 11201.

### **Downeast Schooners**

A number of fine works are available, some better choices are:

Haley, N. **The Schooner Era**. New York: A.S. Barnes and Company, 1972.

Giles, M.S.T. **The Last Sail Down East**. Barre, Massachusetts: Barre Publishers, 1965. This is a valuable book for finding out about individual ships such as the *Rebecca R. Douglas*, p. 118. Several important hulks which can be seen are listed in **Last Sail** including *Cora F. Cressey* which is now being used as a breakwater in Bremen, Maine to enclose a lobster pound. *Hesper* and *Luther Little* are in the harbor at Wiscasset, Maine as crumbling wrecks.

Leavitt, J.F. **Wake of the Coasters**. Middleton, Connecticut: Wesleyan University Press, 1970. This book served to reawaken those interested in schooners and the possibility of a renewal of sailing cargo trade. The *John F. Leavitt*, it's beginning and tragic demise are described in the following newspaper and magazine articles: Spectre, P.H. "The Abandonment of the *John F. Leavitt*," **Wooden Boat** no. 33, pp. 20-28 (March/April 1980). This article describes the maiden voyage and tragic loss of the "Last Downeaster." On a more joyous theme, the launching of the *Leavitt* was heralded by Jane Day in "The Return of Working Sail," **Wooden Boat** no. 31, pp. 18-23 (November/December, 1979). Newspaper, and other magazine accounts include:

"Age of Sail to the Briny Deep," **Maine Times**, January 4, 1980, p. 5.

"Coastal Schooner 'Leavitt' Abandoned off Long Island," **Down East Magazine** (March, 1980), p. 87.

"9 Rescued from Schooner," **Bangor Daily News**, December 28, 1979, p. 1.

"Big Waves Swamp Leavitt," **Portland Press Herald**, December 28, 1979, p. 1.

"Schooner Sinking Off Long Island," **New York Times**, December 28, 1979, p. 15.

"Shipper of Cargo Schooner Vows to Raise Her and Pursue Profit," **New York Times**, December 29, 1979, p. 12.

"Search for Schooner Abandoned," **Portland Press Herald**, December 29, 1979, p. 1.

"Boat Yard Owner Expresses Shock," **Bangor Daily News**, December 29, 1979, p. 4.

### **Grand Banks Schooners**

Several references describe the relationship between fishing and sailing schooners, included are:

Boeri, D. and Gibson, J., **Tell It Goodbye, Kiddo**. Camden, Maine: International Marine Publishing Company, 1976.

Thomas, G.W. **Fast and Able**. Gloucester, Massachusetts: Historic Ship Associates, 1968.

Nova Scotia Department of Fisheries, **Sea, Salt, and Sweat**. Order from Nova Scotia Communications, Box 2206, Halifax, Nova Scotia, Canada B34.

A well-illustrated article on the Portuguese fishermen and their dory schooner was written by James H. Pickerell, "Dory on the Banks," **National Geographic**, Volume 133, No. 4 (April 1968), pp. 572-583.

For people interested in detail on the fish caught on the Banks, an inexpensive paperback is W.B. Scott and S.N. Messieh, **Common Canadian Atlantic Fishes**, St. Andrews, New Brunswick, Canada: The Huntsmen Marine Laboratory, 1976.

Teachers interested in using **Captains Courageous** as a class reading project can purchase class sets of a specially shortened version edited for middle school-junior high school readers from:

Adopted Classics Series  
Scot Foresman  
1900 East Lake Avenue  
Glenview, Illinois 60025

### **Commercial Fishing**

Few books are published on this topic. There are several fine newspapers in our region which provide information for and about commercial fisheries including vessel types and new gear development.

**Commercial Fisheries News**, Stonington, Maine 04681

**National Fisherman**, International Marine Publishing Company, Camden, Maine 04843.

### **Steam Vessels**

A description of the *Katahdin* is contained in the Moosehead Marine Museum Newsletter available from:

Moosehead Marine Museum  
P.O. Box 116  
Greenville, ME 04441

Books on the topic include:

Stanton, S.W. **Coastal Steam Vessels**, Upper Montclair, New Jersey: H. Kneeland Whiting, 1974.

Ryan, Allie. **Penobscot Bay, Mount Desert and Eastport Steamboat Album**. Camden, Maine: Down East Publishing, 1972.

### **Charts**

Navigational Charts may be purchased from local marinas and chandleries or ordered from:

Distribution Division, C44  
National Ocean Survey  
Riverdale, Maryland 20840  
Telephone: 301-436-6990

To obtain order numbers and prices for charts request  
Nautical Chart Catalog 1 (free).

Chart symbols are contained in Chart No. 1 (\$1.65).

Authorized Chart Dealers are listed in the Chart  
Catalog. The largest inventory in the region is held by:

The Chart Room  
Chase Leavitt and Company  
10 Dana Street  
Portland, Maine

In New Hampshire:  
Hampton Beach Marina  
55 Harbor Road  
Hampton Beach, NH

### **Canals**

A number of canals traversed sections of Southern  
Maine and New Hampshire. One such canal, the  
Cumberland and Oxford Canal (1830-1870) reached from  
Sebago Lake to Portland. The Cumberland and Oxford  
Canal Association publishes a pamphlet describing the  
canal. Inquiries should be addressed to:

Mr. Ralph Willis  
121 Mosher Road  
So. Windham, Maine 04082

### **Lumbering and Boats**

Some information, photographs and equipment including  
a bateau can be seen at:

The Patten Lumberman's Museum  
Patten, Maine 04765  
Phone: 528-2650

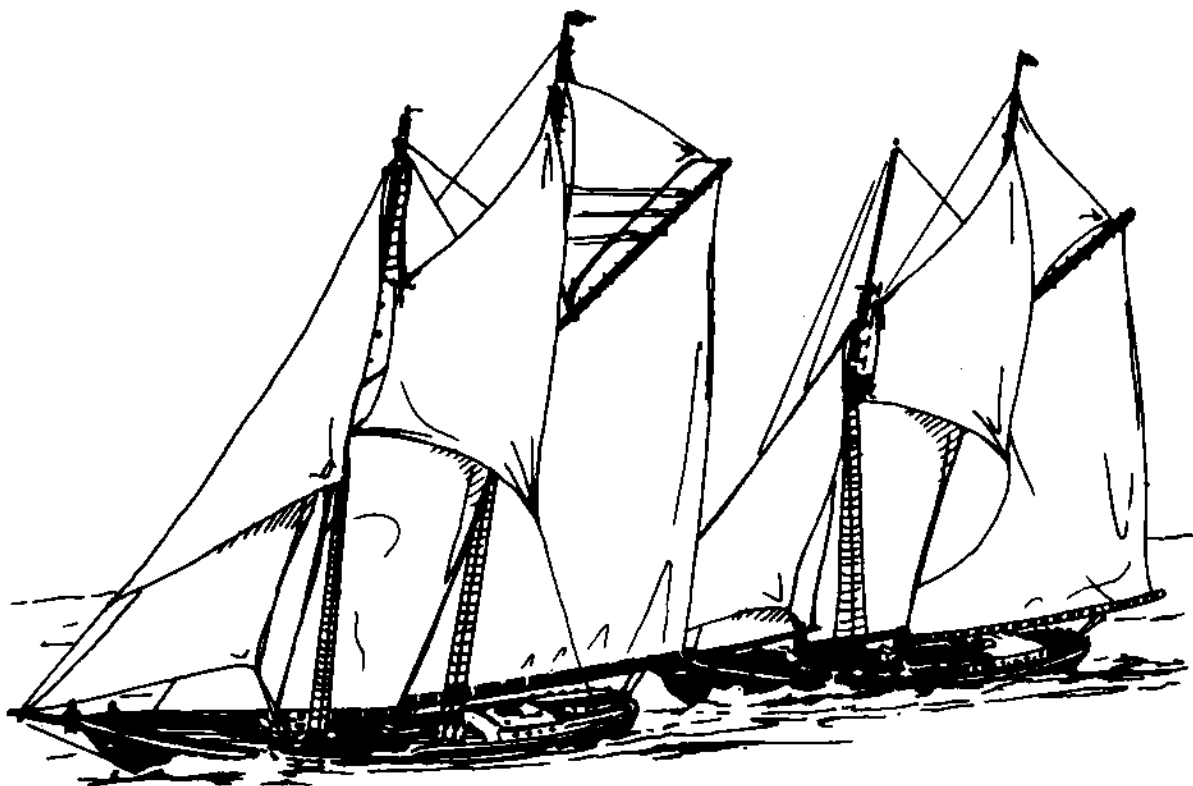

# Places to Visit

In preparation for this guide project staff undertook a questionnaire study of over 300 museums, historical societies and other similar agencies. Names of groups to contact were supplied by the State Libraries and Marine Advisory Service personnel of Maine and New Hampshire. Those agencies returning data are included in the

following directory and checklist. Numbers in the checklist correspond to numbers appearing with listings in the directory. Not all agencies listed in the directory supplied us checklist data and hence some agencies in the checklist are described incompletely.

## A Directory of Historic Maritime Collections and Vessels

1. **Allie Ryan Collection**  
Maine Maritime Academy  
Castine, ME 04221  
\*Tel. 326-4311
2. **Belfast Museum, Inc.**  
66 Church Street  
Belfast, ME 04915  
Tel. 338-2078, M.L. Slugg
3. **The Brick Store Museum**  
117 Main Street  
Kennebunk, ME 04043  
Tel. 985-4802, Sandy Armentrout
4. **Brunswick Public Library**  
Pleasant and Middle Streets  
Brunswick, ME 04011  
Tel. 725-5242, Brian Damien
5. **Camden Public Library**  
Camden, ME 04843  
Tel. 236-3440, Mrs. Nellie A. Hart,  
Librarian
6. **Camden-Rockport Historical  
Society**  
P.O. Box 897  
Conury Road  
Camden, ME 04843  
Tel. 236-2257 (July-August only),  
Mrs. T.S. Sprague
7. **Castine Scientific Society**  
Wilson Museum  
Perkins Street  
Castine, ME 04421  
Tel. 326-2753, E.W. Doudiet
8. **The Children's Museum**  
746 Stevens Avenue  
Portland, ME 04103  
Tel. 797-3353, Barbara E. Lechman
9. **Colby College Museum of Art**  
Waterville, ME 04901  
Tel. 873-1131, Ext. 221,  
Margaret Wickes
10. **Deer Isle-Stonington  
Historical Society**  
Deer Isle, ME 04627  
Tel. 348-2886, Mrs. Victor Welcome
11. **Dresden Historical Society**  
Dresden, ME 04342  
Tel. 737-8892, Eleanor L. Everson
12. **Fairfield Historical Society**  
Lawrence Avenue  
Fairfield, ME 04937  
Tel. 453-6867, Coraie Tozier
13. **Fogler Library**  
The Cole Marine Collection  
University of Maine at Orono  
Orono, ME 04469  
Tel. 581-7781, Edward Kellogg
14. **Fort Western Museum**  
Bowman Street  
Augusta, ME 04330  
Tel. 622-1234, 623-8540 (off season),  
S. Webber
15. **Freeport Historical Society**  
45 Main Street  
Freeport, ME 04032  
Tel. 865-3024, Mary-Eliza Wengren  
865-6292, Becky Grant
16. **Grand Banks Schooner Museum**  
100 Commercial Street  
Boothbay Harbor, ME 04530  
Tel. 633-5603
17. **Historic Landmarks, Inc.**  
P.O. Box 312  
York, ME 03909  
Tel. 363-4974, Mary Pietsch
18. **Islesboro Historical Society**  
Islesboro, ME 04848  
Tel. 734-6439, Dr. R.K. Pendleton
19. **Kittery Historical and  
Naval Museum**  
P.O. Box 453  
Kittery, ME 04027  
Tel. 439-3060, Bruce Follansbee
20. **Lincoln County Cultural and  
Historical Association**  
Wiscasset, ME 04578  
Tel. 882-6817, Helen T. Gibson
21. **Maine Marine Museum  
(Bath Maritime Museum, BMM)**  
963 Washington Street  
Bath, ME 04530  
Tel. 443-6311, Mrs. Marnee Small
22. **Maine State Museum**  
State House Station 83  
Augusta, ME 04333  
Tel. 289-2301
23. **Maine State Library**  
LMA Building, State House Station 64  
Augusta, ME 04333  
Tel. 289-3561, Reference Department
24. **Monmouth Museum**  
Monmouth, ME 02259  
Tel. 933-4444, A. Earl Flanders
25. **Moosehead Marine Museum**  
Box 1151  
Greenville, ME 04441  
Tel. 695-2716, Elliott N. Levy
26. **Northeast Archives of  
Folklore and Oral History**  
South Stevens Hall  
University of Maine at Orono  
Orono, ME 04469  
Tel. 581-7466, Sandy Ives
27. **North Yarmouth Historical  
Society**  
P.O. Box 391  
Cumberland Center, ME 04021  
Tel. 829-3628, Urusal Baier
28. **Nutting Memorial Library**  
Maine Maritime Academy  
Castine, ME 04421  
Tel. 326-4311, Ext. 246, K.H. Anthony

\* all area codes are (207) except as noted.

(continued)



**29. Old Berwick Historical Society**  
South Berwick, ME 03908  
Contact: Fred Green  
P.O. Box 128  
Rollinsford, NH 03869  
Tel. 603-742-8583

**30. Old Gaol Museum**  
York and Lindsay Streets  
P.O. Box 188  
York, ME 03909  
Tel. 363-3872, Kerry O'Brien

**31. Orland Historical Society**  
Main Street  
Orland, ME 04472  
Tel. 469-2184, Doris Hutchins

**32. Pejepscot Historical Society**  
11 Lincoln Street  
Brunswick, ME 04011  
Tel. 729-4622, Elizabeth Copeland

**33. Penobscot Heritage Museum**  
159 Union Street  
Bangor, ME 04401  
Tel. 942-5766

**34. Penobscot Marine Museum**  
Seasport, ME 04974  
Tel. 548-6634, Janice Kasper

**35. Peary MacMillan Arctic Museum**  
Bowdoin College  
Brunswick, ME 04011  
Tel. 725-8731, Ext. 416, John Coffey

**36. Portland Museum of Art**  
111 High Street  
P.O. Box 4018, Station A  
Portland, ME 04101  
Tel. 775-6148, Debbie Zorach

**37. Portsmouth Athenaeum**  
9 Market Square  
Box 848  
Portsmouth, NH 03801  
Tel. 603-431-2538

**38. Raymond-Casco Historical Society**  
c/o Ernest H. Knight  
Raymond, ME 04071  
Tel. 655-4231

**39. Shore Village Museum**  
104 Limerock Street  
Rockland, ME 04841  
Tel. 549-4950, Priscilla Adams

**40. Sullivan-Sorrento Historical Society**  
c/o Mrs. G.H. Watson  
RFD 1, Box 104  
East Sullivan, ME 04607  
Tel. 422-6253, Ruth Watson

**41. The Tate House**  
1270 Westbrook Street  
Portland, ME 04102  
Tel. 772-2023, Mrs. M.S. Peabody

**42. Thomaston Historical Society**  
Knox Street  
Thomaston, ME 04861  
Tel. 354-6822, Mrs. Frank Schoeder

**43. William A. Farnsworth Library and Art Museum**  
P.O. Box 466  
Rockland, ME 04841  
Tel. 596-6457,  
Christine Bauer Rodmaniczky

**44. Willowbrook at Newfield**  
P.O. Box 80  
Newfield, ME 04056  
Tel. 793-2784, Mr. King or Mrs. Perry

**45. Winnepesaukee Flagship Corp.**  
P.O. Box 367  
Weirs Beach, NH 03246  
Tel. 366-5531, R.M. Brown  
(operates M.V. Mt. Washington)

**46. Penobscot Heritage Museum**  
Bangor Historical Society  
159 Union Street  
Bangor, Maine 04401  
Telephone: 942-0398, Pat Wood  
(Instructional Resource Center,  
Bangor Public Schools)

# Checklist of Maritime Oriented Materials and Services

Museum, Library, Historical Society	Paintings, Drawings, Sketches	Marine Displays Exhibits etc.	Historical Marine Artifacts	Contemporary Marine Materials	Marine Literature Assessable	Actual Structure of a Ship etc.	Models of Ships Schooners etc.	Other Marine Related Materials
1	X							
2	X	X	X					
3	X	X	X		X			
4	X		X		limited		X	
5	X	X			X		X	
6	X		X	X				
7	X	X	X	X			X	
8		X		X				
9								X
10	X	X						
11	photos	X						X
12					X			
13					X			
14	X	X	X	X			X	
15	X		limited				X	
16		X					X	films
17		X	X					Gundalows
18	X	X	X					
19	X	X	X	X	X		X	
20	photos	limited						
21	X	X	X	X	X	X	X	X
22	X	X	X	X		X	X	
23					X			
24	X		X			X		
25	photos	X	X		X	X		
26	limited				X			
27								Archives
28	X	X	X		X			
29	X	X	X		X		X	
30	X	X	X	X			X	
31			X					
32	X	X	X		Archives			X

(continued)

**Checklist of Maritime Oriented Materials and Services Cont'd.**

Museum, Library, Historical Society	Paintings, Drawings, Sketches	Marine Displays Exhibits etc.	Historical Marine Artifacts	Contemporary Marine Materials	Marine Literature Assessable	Actual Structure of a Ship etc.	Models of Ships Schooners etc.	Other Marine Related Materials
33	X	X					X	photos
34	X	X	X	X	X	X	X	X
35	X	X	X					
36	X	X	X					
37	X	X	X					
38								X
39	X	X	X	X		X		
40	X	periodically	X					
41	X	X	X					X
42	X	X	X					
43	X	X	X				X	
44	X	X	X	X				
45								Boat trips

**A List of Boatyards**

The list of boatyards given below was compiled by Dr. John Battick, Maritime Historian at the University of Maine at Orono. These include only yards in Maine, which are listed by County. This list is intended as a partial listing. Other boatyards may be located in local telephone directories or as advertisers in **Wooden Boat, National Fisherman, or Commercial Fisheries News.**

The service code used in this listing is:

- A. Boatbuilding
  - A1. in wood
  - A2. in steel
  - A3. in fiberglass
- B. Shipbuilding
- C. Repairs and service
- D. Marine hardware and equipment

**Lincoln County**

- Atlantic Boat Works, Boothbay Harbor A
- Coastal Plastics, Inc., E. Boothbay A3
- R.N. Fish and Son, Inc., Boothbay Harbor C
- Harvey F. Gamage Shipbuilder, Inc., S. Bristol A, B
- Goudy & Stevens, E. Boothbay A, D
- Hodgdon Brothers, E. Boothbay A
- George I. Hodgdon, Jr., Inc., E. Boothbay A
- J. Ervin Jones Co., E. Boothbay A
- Lincoln Canoes Inc., E. Boothbay A
- Paul E. Luke, Inc., E. Boothbay A, D
- Padebeco Custom Boats, Round Pond A

- Reed's Shipyard of Boothbay, Boothbay Harbor A
- Chetley A. Rittal Co., Boothbay Harbor A
- Frank L. Sample & Sons, Inc., Boothbay Harbor C
- Shew & Burnham, Inc., S. Bristol A
- Todd Boat Co., Inc., W. Southport A3

**Penobscot County**

- Bandwin Boat Co., Orrington A3
- Old Town Canoe Co., Old Town A3
- Rivers and Gilman Moulded Products, Hampden A3

**Sagadahoc County**

- Bath Iron Works, Bath A 2, B, C

**Somerset County**

- Corson Boat Co., Madison A3

**Waldo County**

- Dark Harbor Boat Yard Corp., Islesboro A
- Duck Trap Woodworking, Lincolnville A1

**Washington County**

- Clinton's Boat Shop, Beals A
- Osmond's Boat Shop, Beals A
- Passamaquoddy Yacht Co., Eastport A3

**York County**

Dion Yacht Yard, Inc., Kittery C  
 Rumery's Boat Yard, Inc., Biddeford A

**Cumberland County**

Aeromarine Corporation, Brunswick D  
 Even Keel Marine Specialties Inc., Yarmouth A  
 John F. Fraser Co., N. Windham C  
 Golten Ship Repair, Inc., Portland A3, C  
 Industrial Welding and Machine, Inc.,  
 Portland C  
 O.P. Peterson Co., Portland D  
 Sabre Yachts, S. Casco A3  
 Sea Strahan Co., Portland C  
 South Portland Shipyard and Marine  
 Railways Corp., South Portland C

**Hancock County**

Bass Harbor Boat Corp., Bernard A  
 Blue Hill Marine, E. Blue Hill A, C  
 Brooklin Boat Yard, Brooklin A1  
 Eaton's Boat Yard, Castine A

Henry R. Hinckley & Co., Manset A3  
 L & H Enterprises, Manset A  
 Narramissic Corp., Orland A, C  
 Jarvis W. Newman Co., Southwest Harbor A  
 Reinforced Plastics Co., E. Sullivan A3  
 James H. Rich Boat Yard, W. Tremont A  
 Southwest Boat Corp., Southwest Harbor A  
 Webber's Cove Boat Yard, Inc., E. Blue Hill A3  
 John Williams Co., Inc., Manset A3  
 Winter Harbor Marine Trading Corp., Winter  
 Harbor C

**Knox County**

J.O. Brown & Son, Inc., North Haven A, D  
 Damariscotta Boats, Inc., Rockland A  
 Georges River Boatbuilding and Repair,  
 Thomaston A, C  
 Lash Brothers Boat Yard, Inc., Friendship A  
 Lee's Boat Shop, Inc., Rockland A  
 Morse Boat Building Co., Inc., Thomaston A  
 National Sea Products Inc., Rockland A, C  
 Newbert & Wallace, Thomaston A  
 Penobscot Boat Works, Inc., Rockport A

# Lines Plan for a Whitehall Boat

PROFILE VIEW

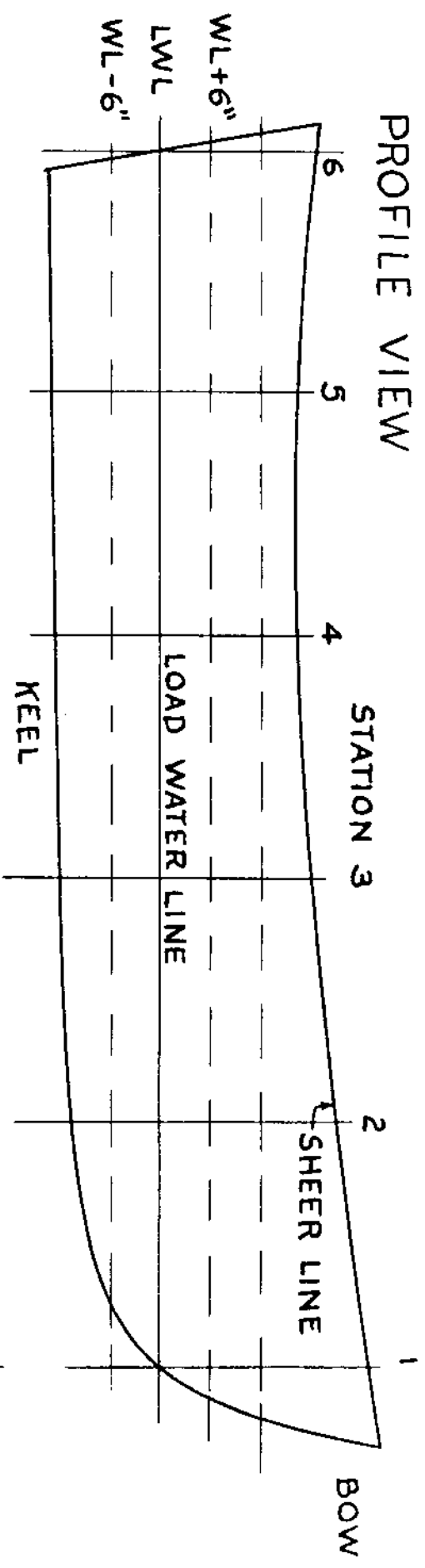

PLAN VIEW

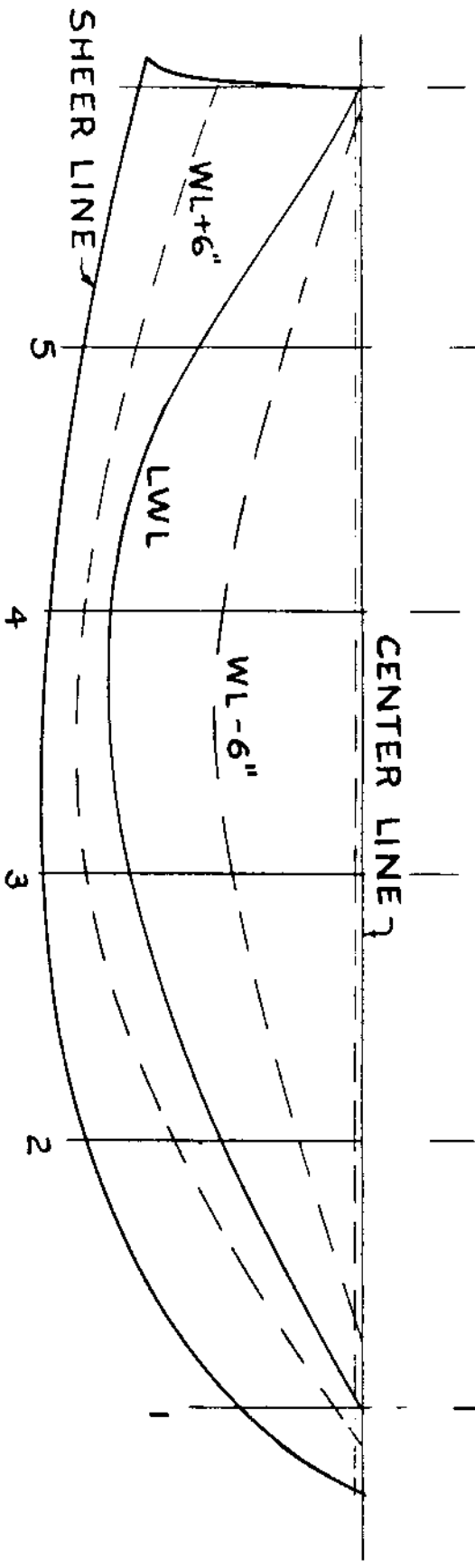

# Body Plan for a Whitehall Boat

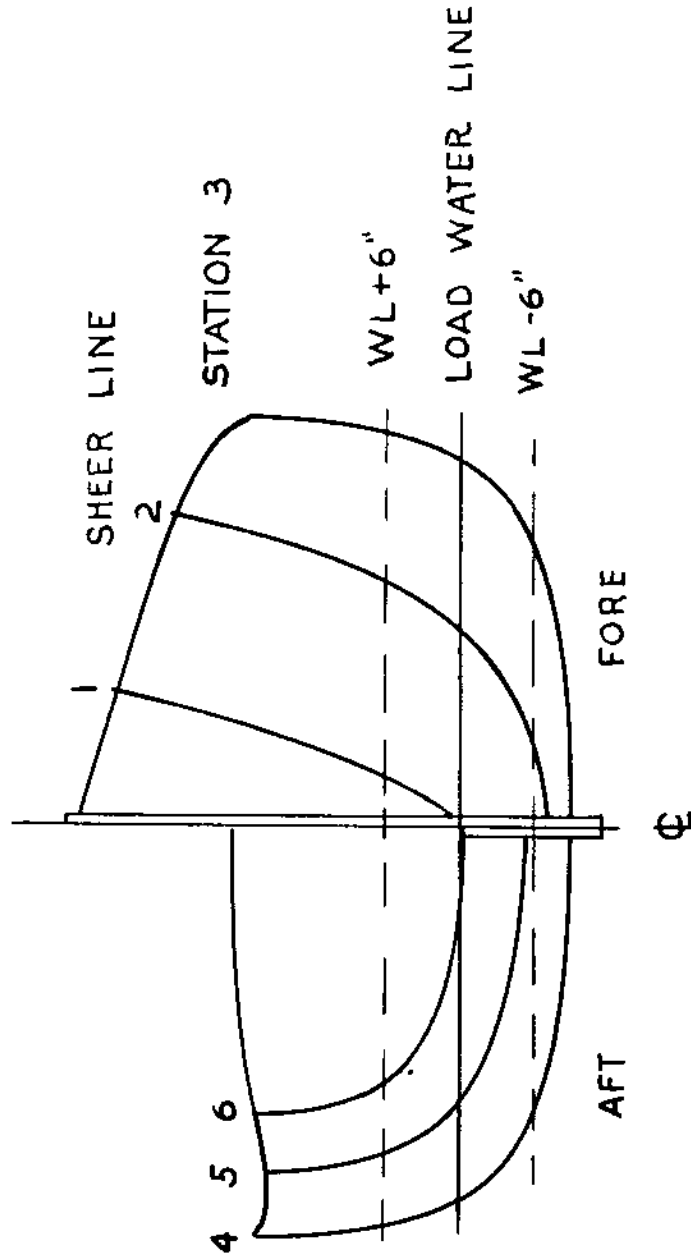
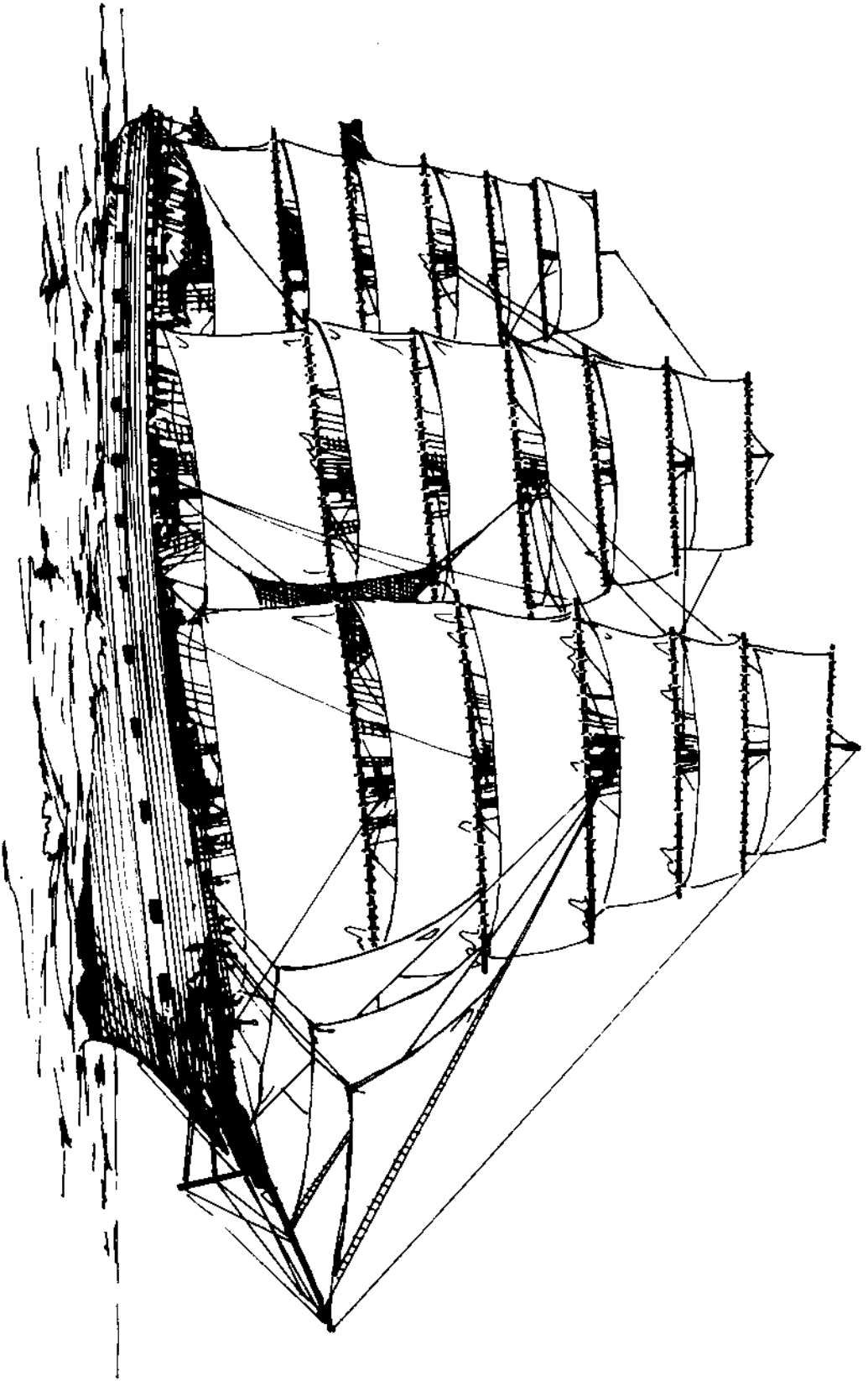

TABLE OF OFFSETS

STATION	1	2	3	4	5	6	STATION
WL+6"	030	112	200	1116	145	0117	WL+6"
LWL	000	097	191	187	112	000	LWL
WL-6"	—	031	132	144	—	—	WL-6"

OFFSETS GIVEN IN FEET, INCHES, AND EIGHTHS



Tea Clipper Under Sail

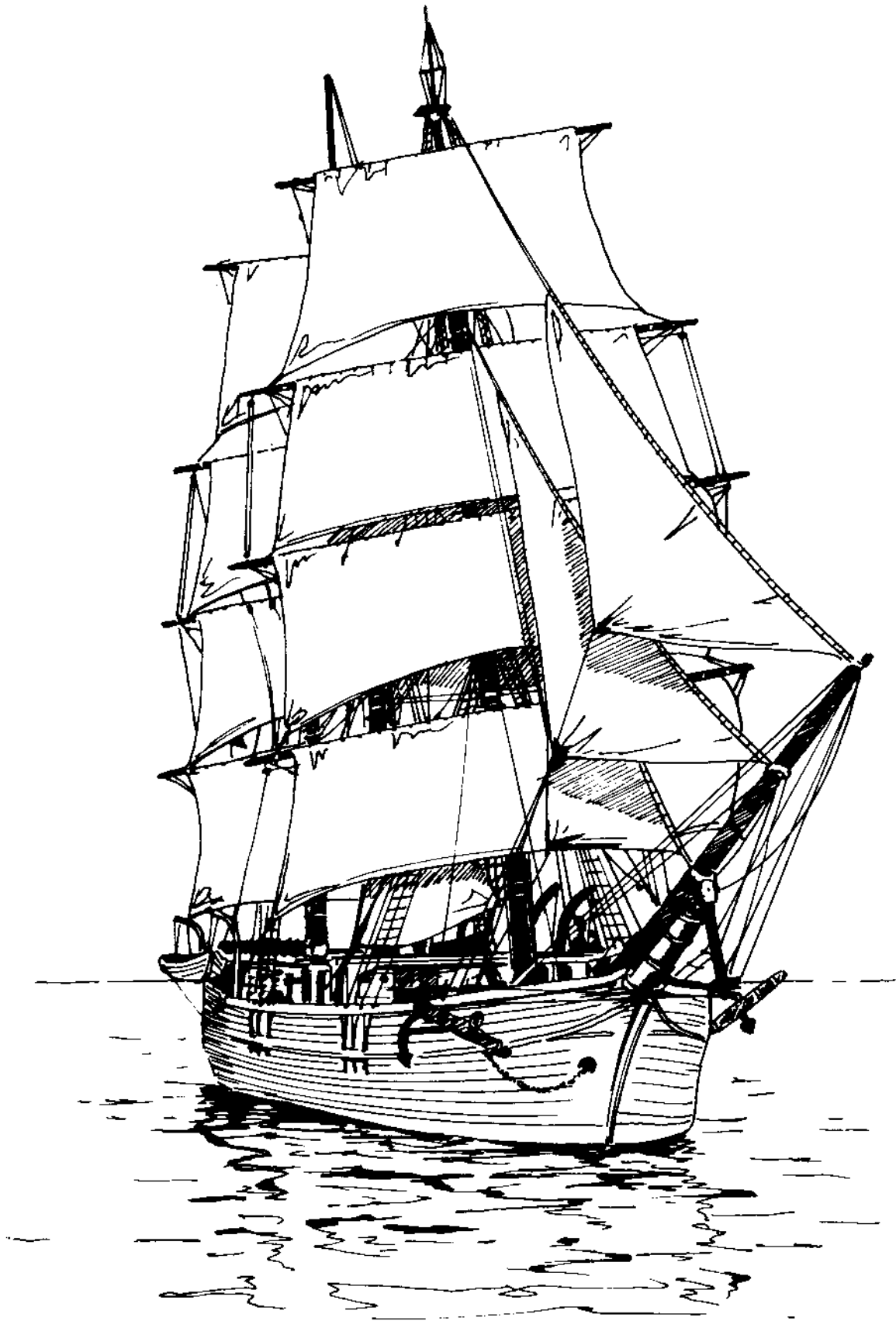

Whaler



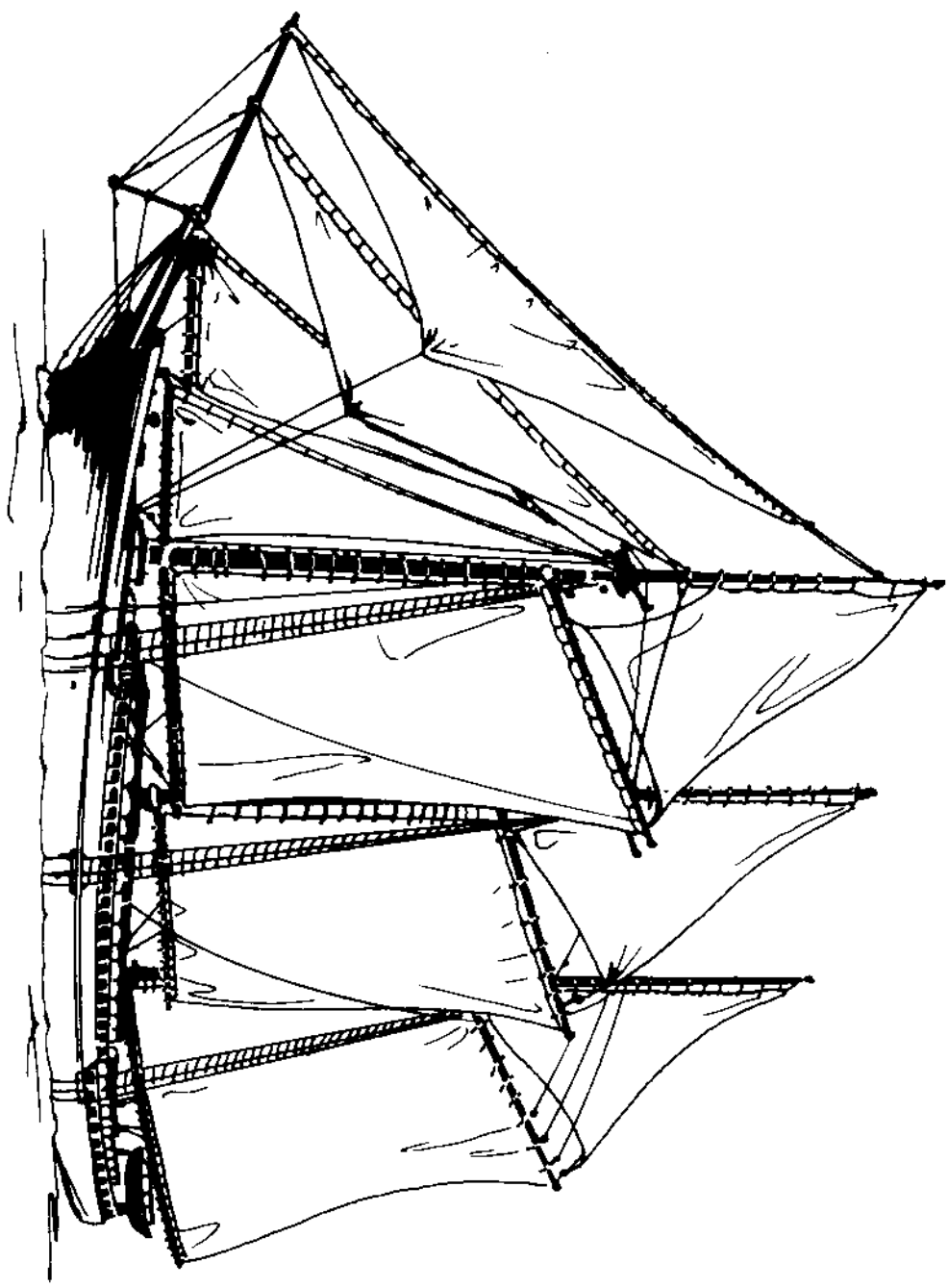

Rebecca R. Douglas

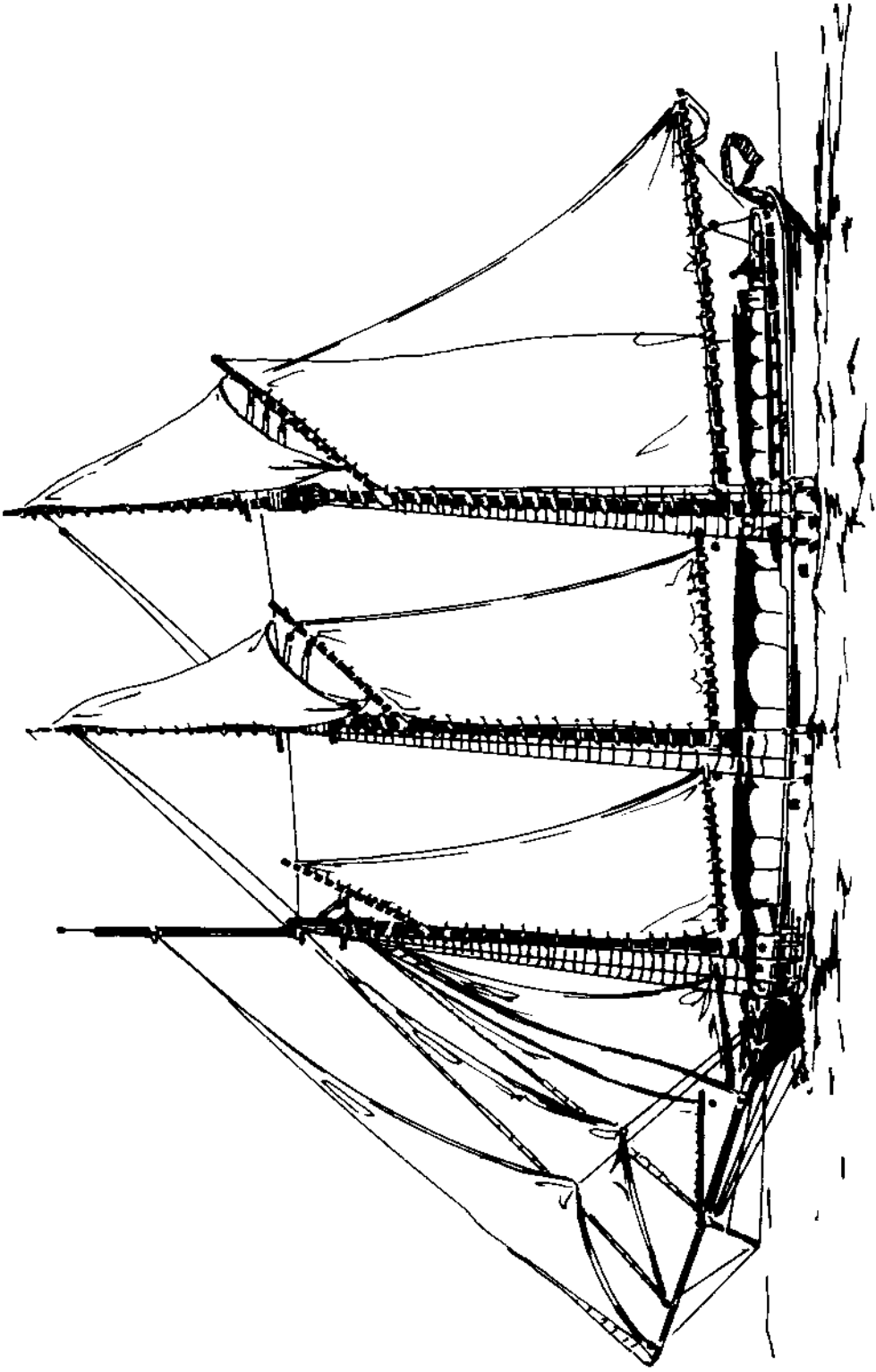

**Mattie J. Alles**

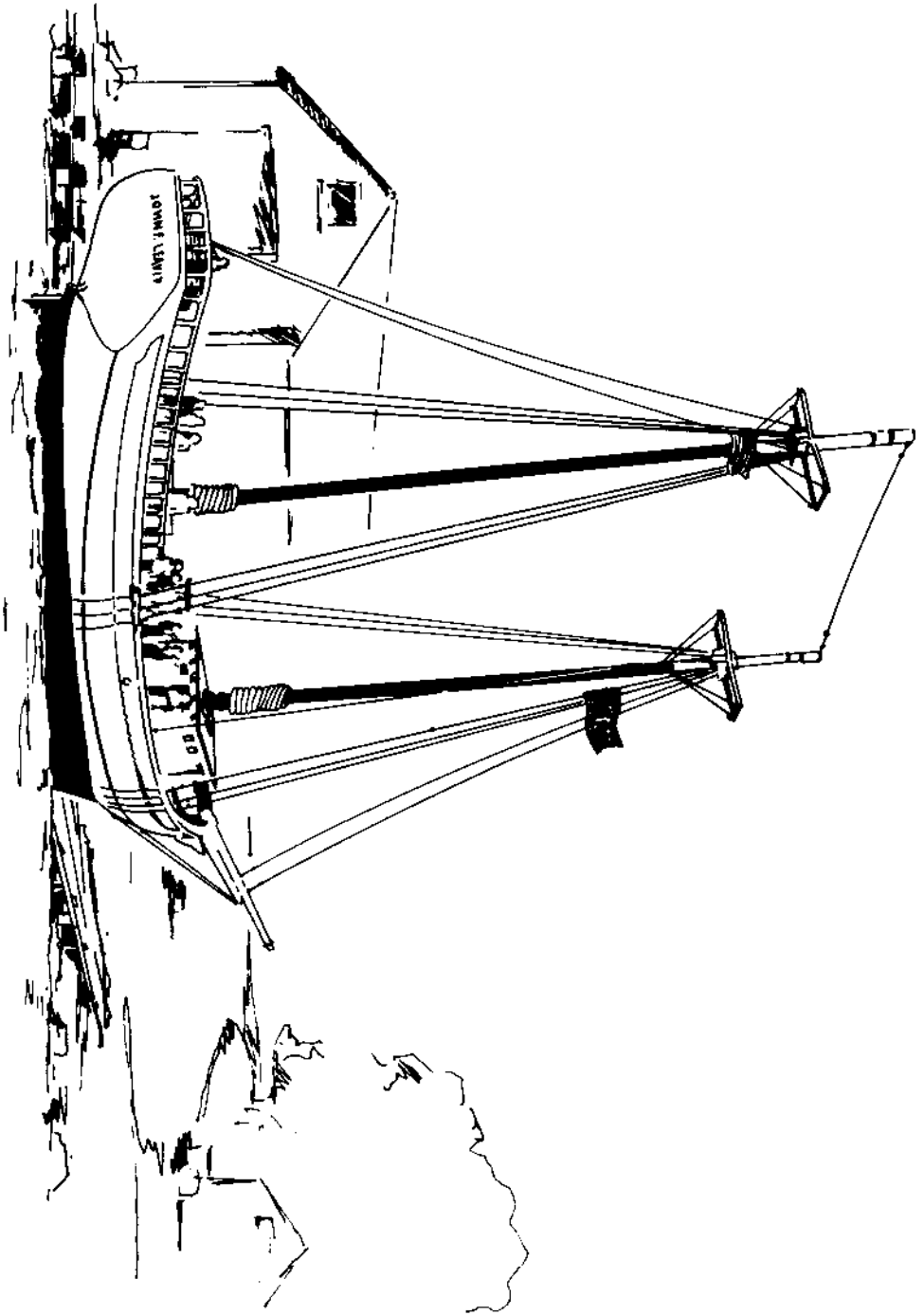

John F. Leavitt

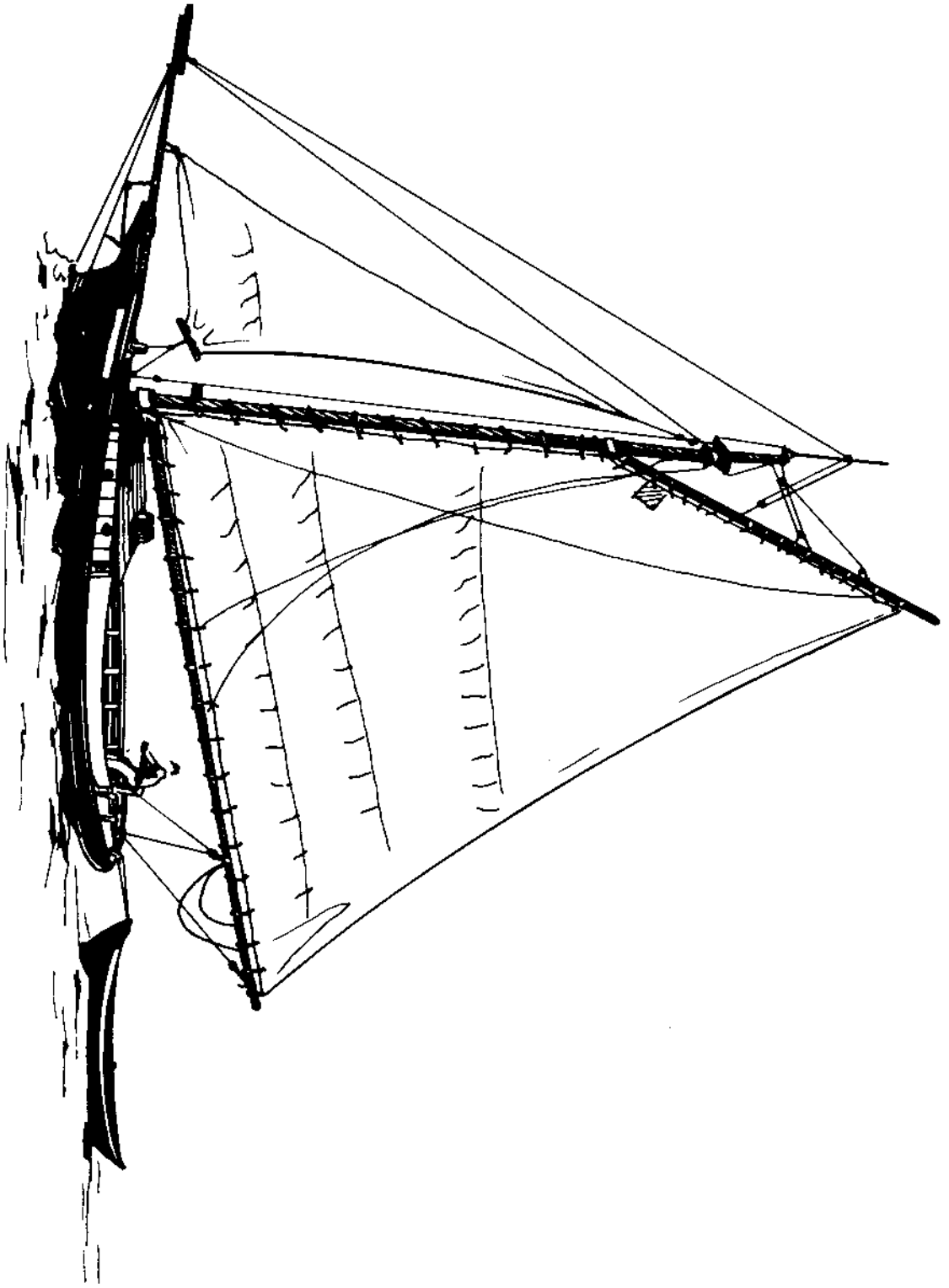

Friendship Sloop

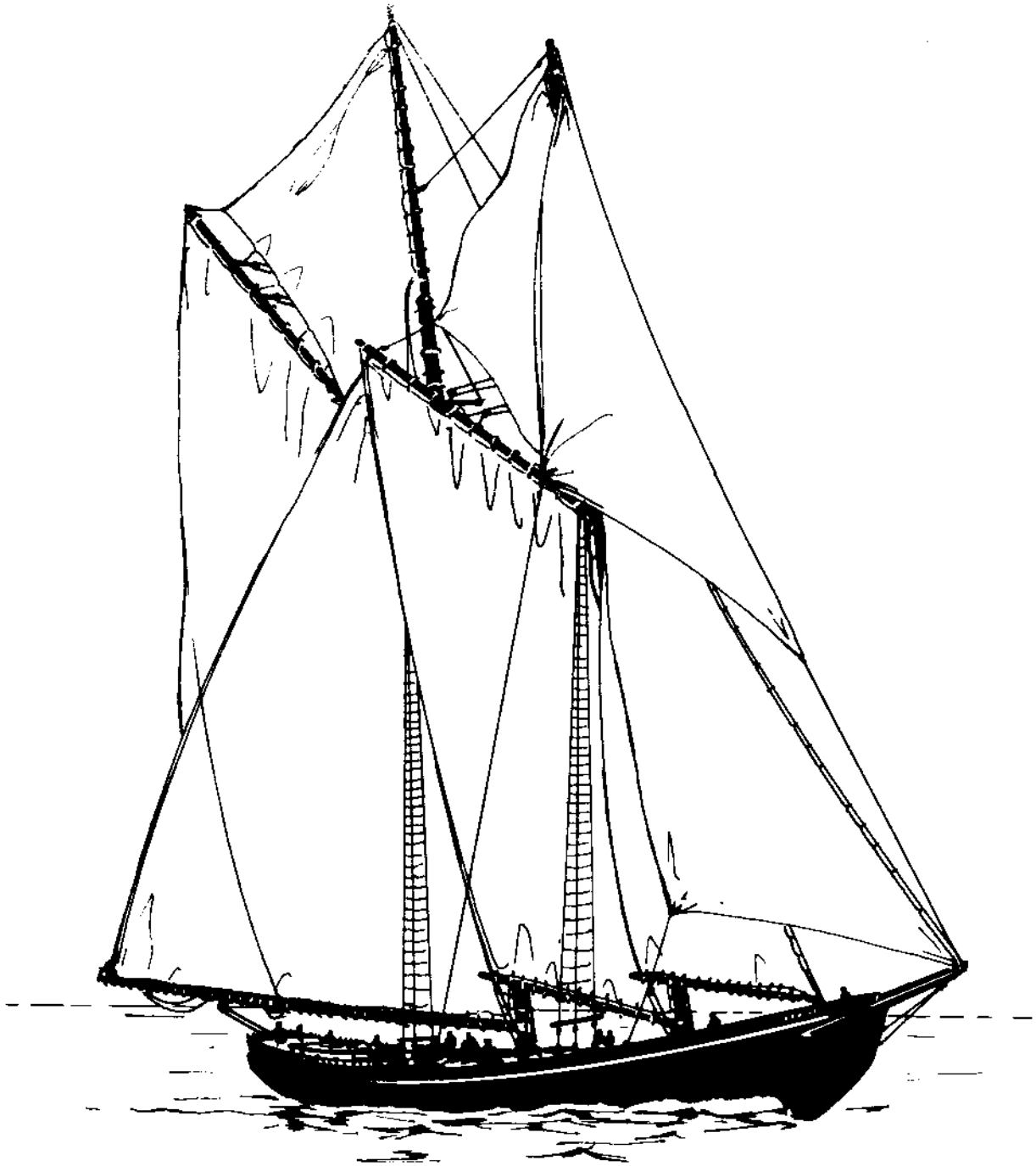

Grand Banks Schooner

# A Maine Coasting Schooner

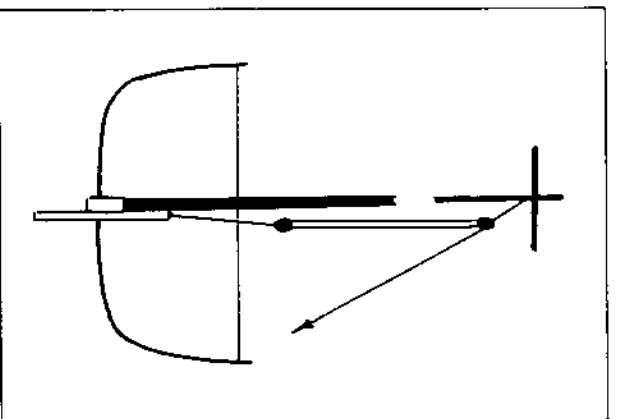
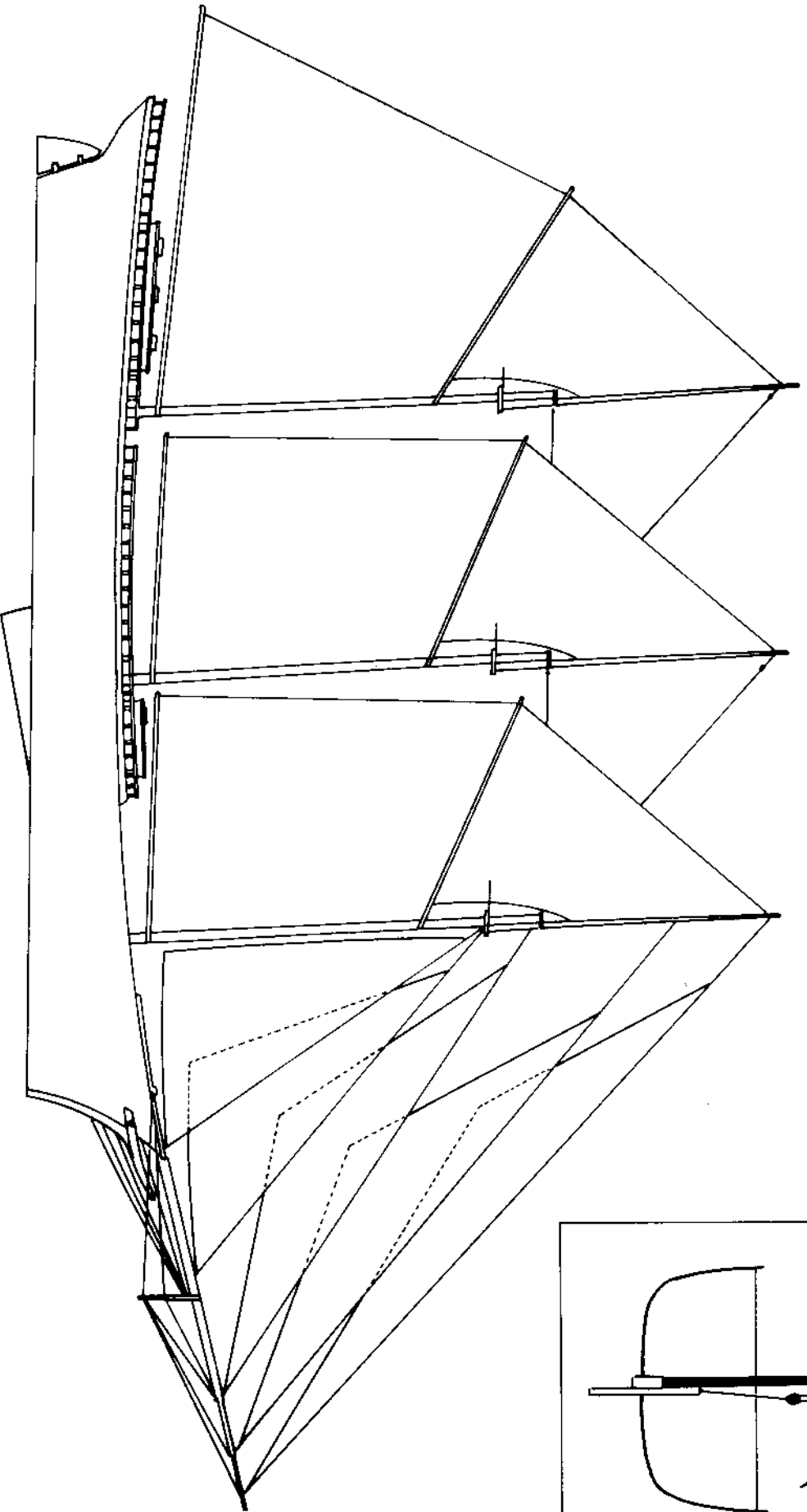

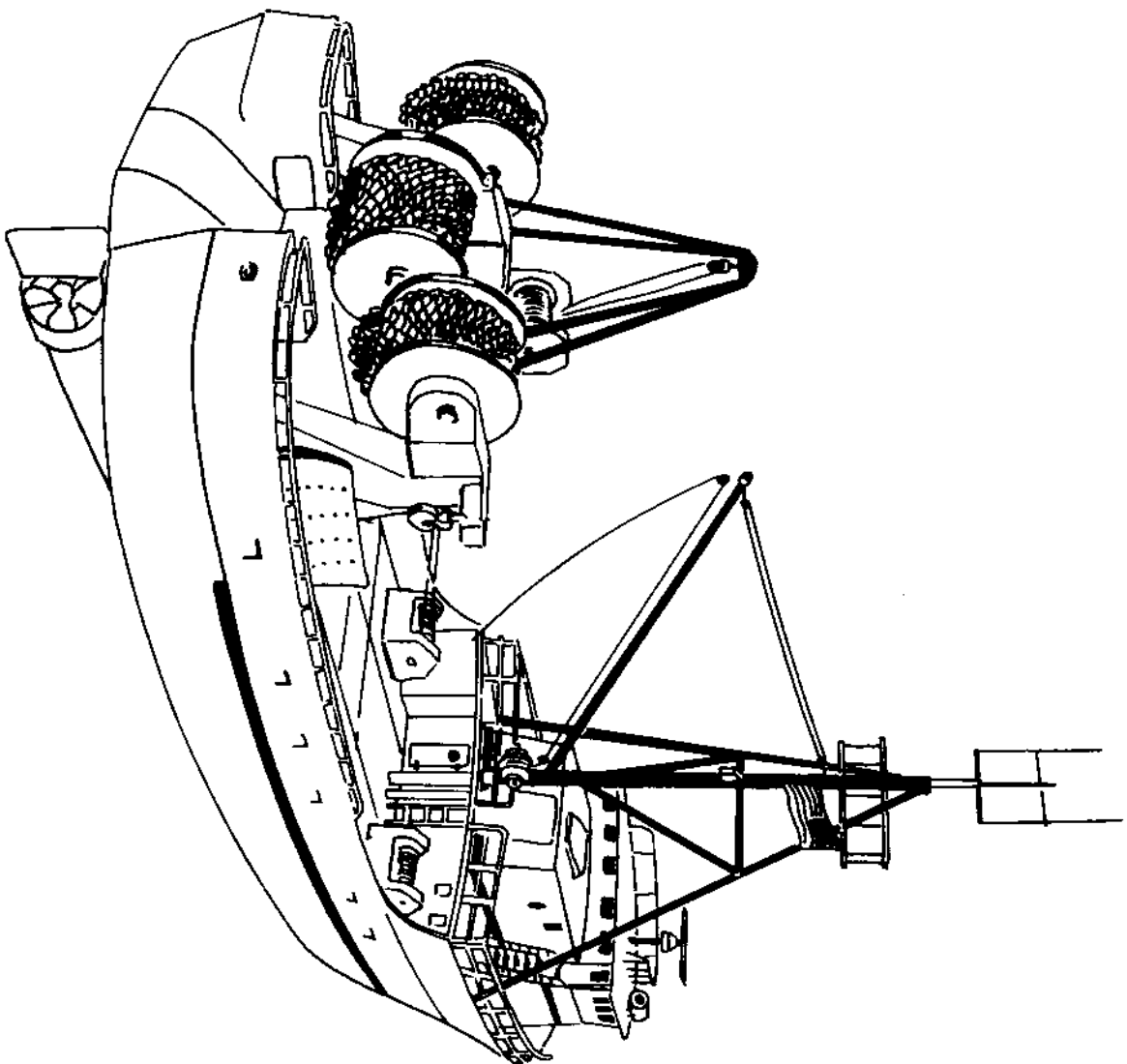

Modern Stern Trawler

# Bottom Trawl

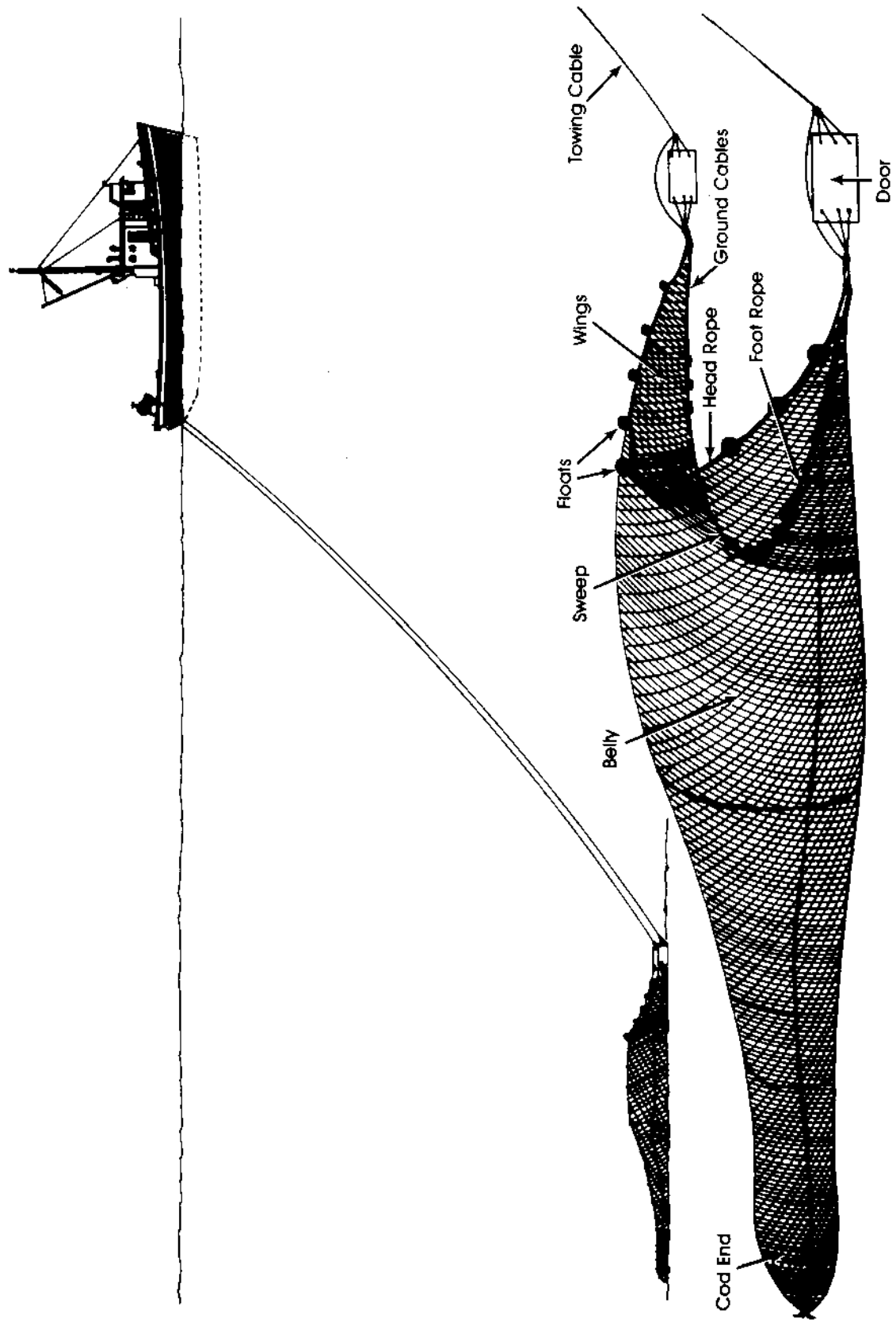



# Making a Dory Model

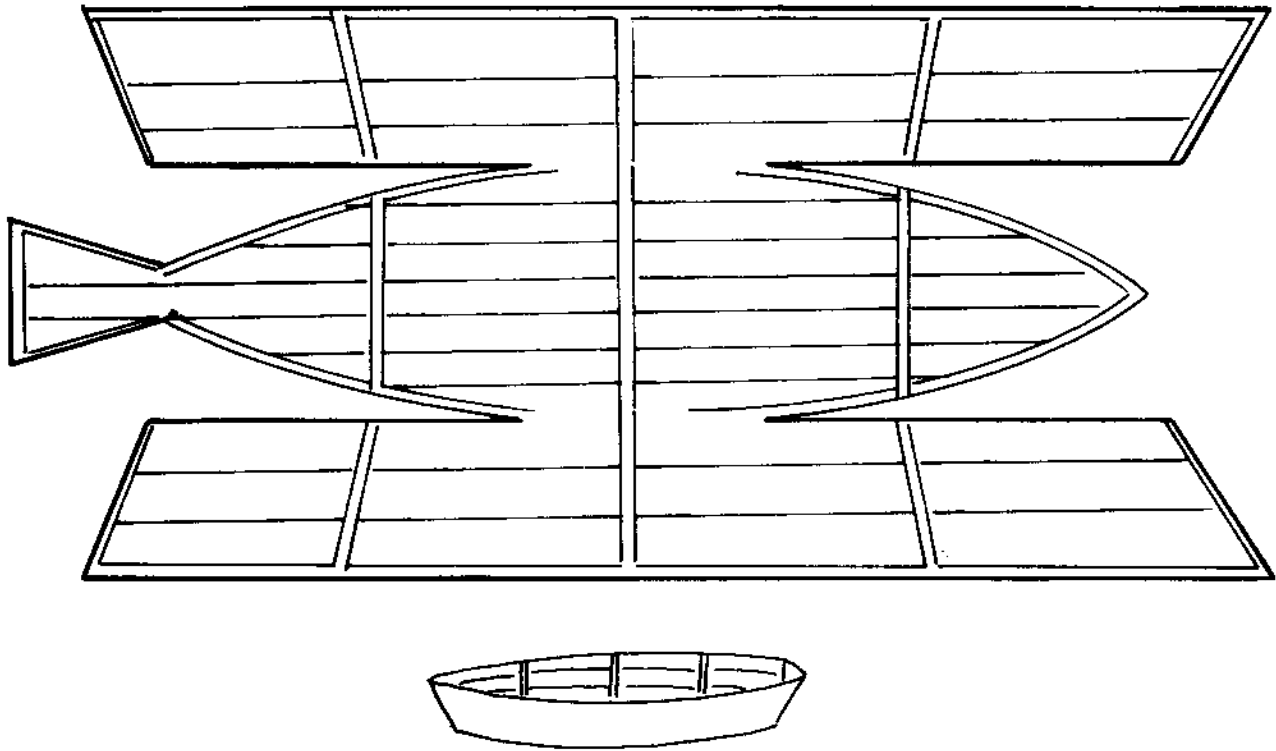

# Canoe Parts

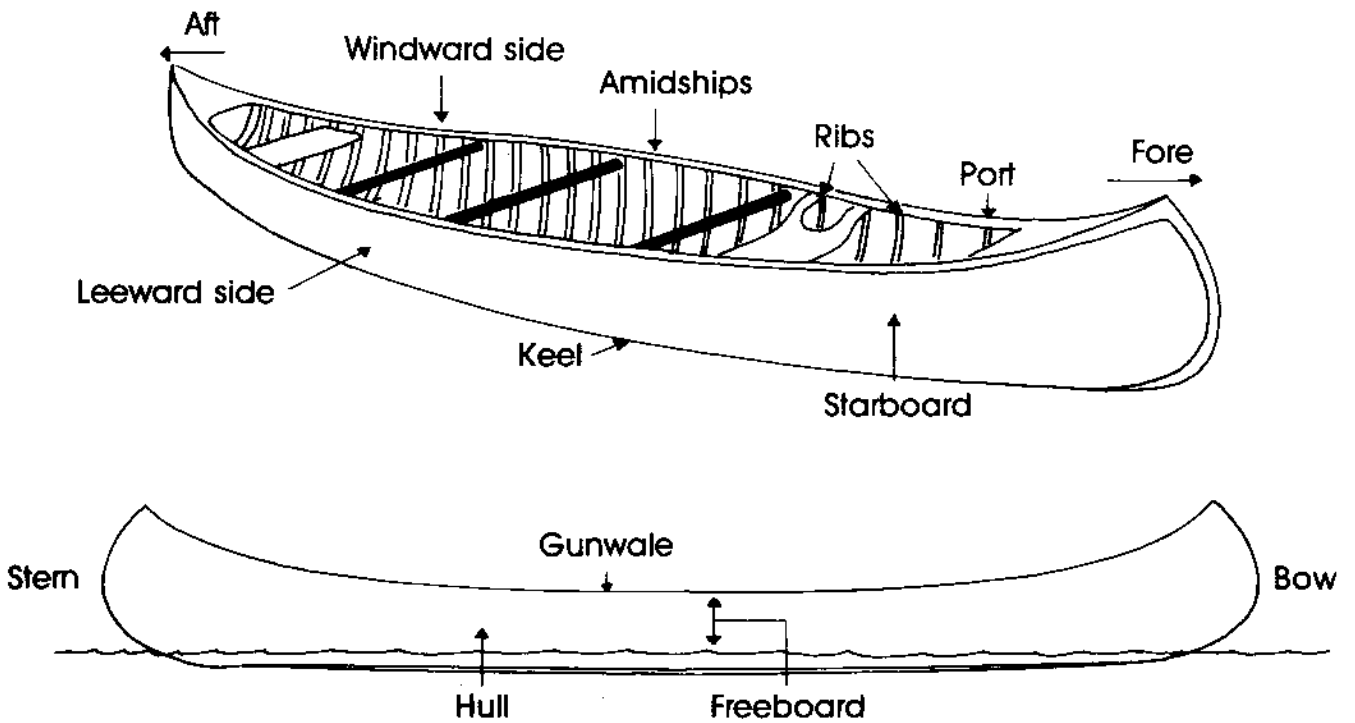

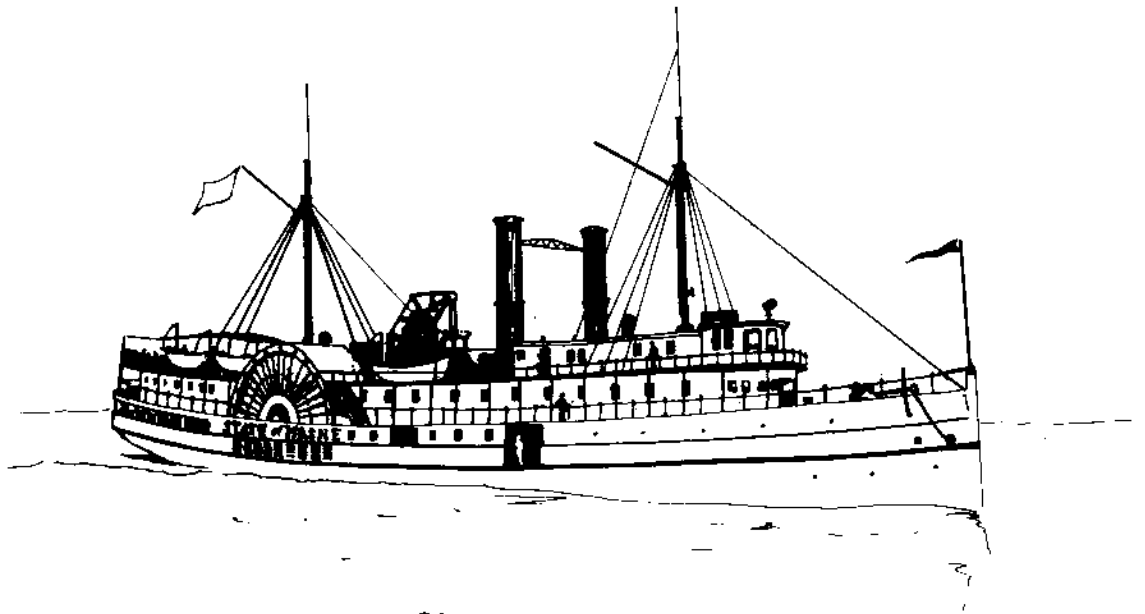

State of Maine

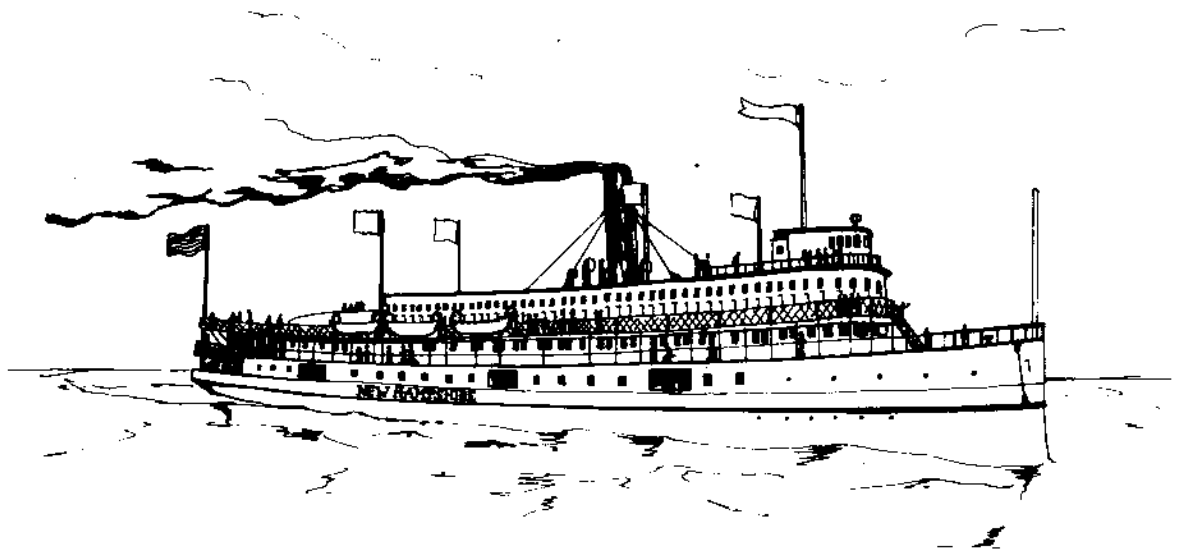

New Hampshire

# Lobster Boat

Station Positions

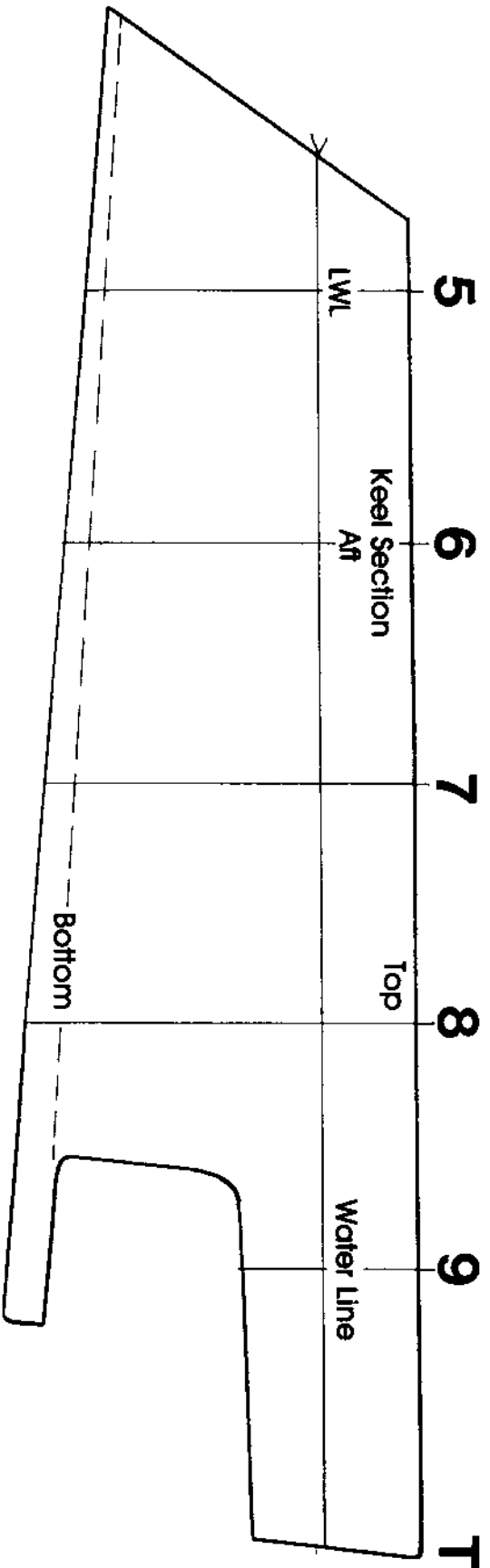

Station Positions

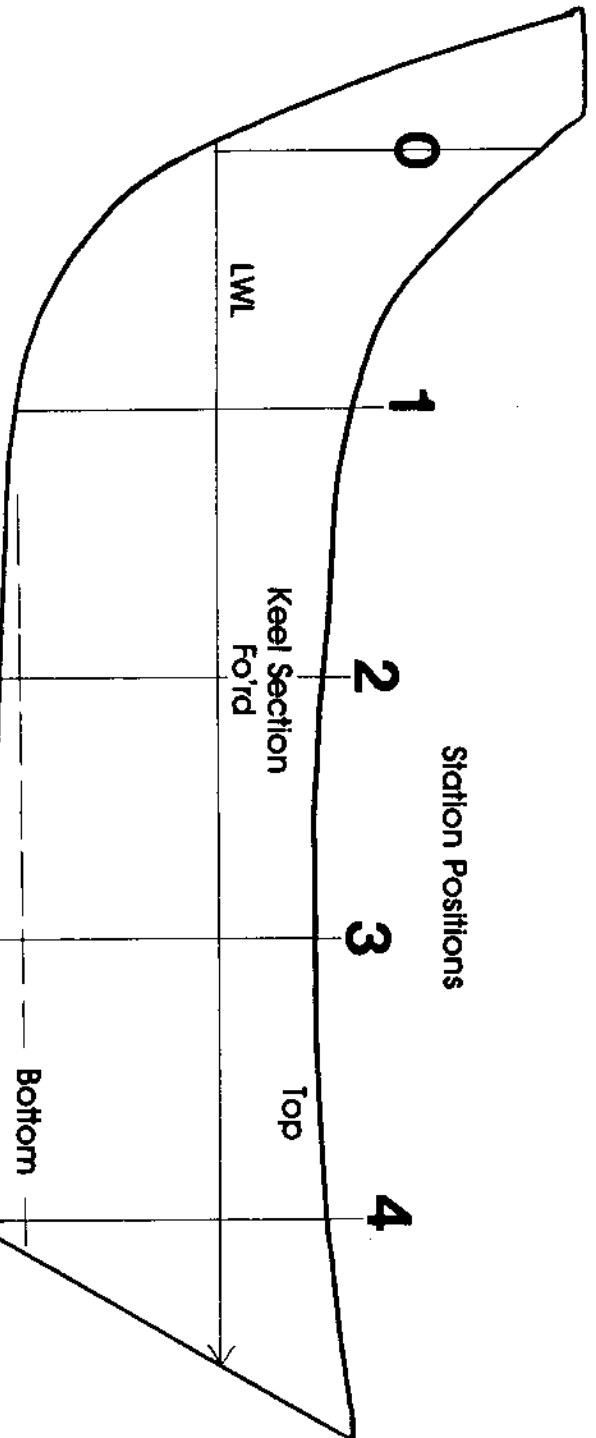

Lobster Boat, continued

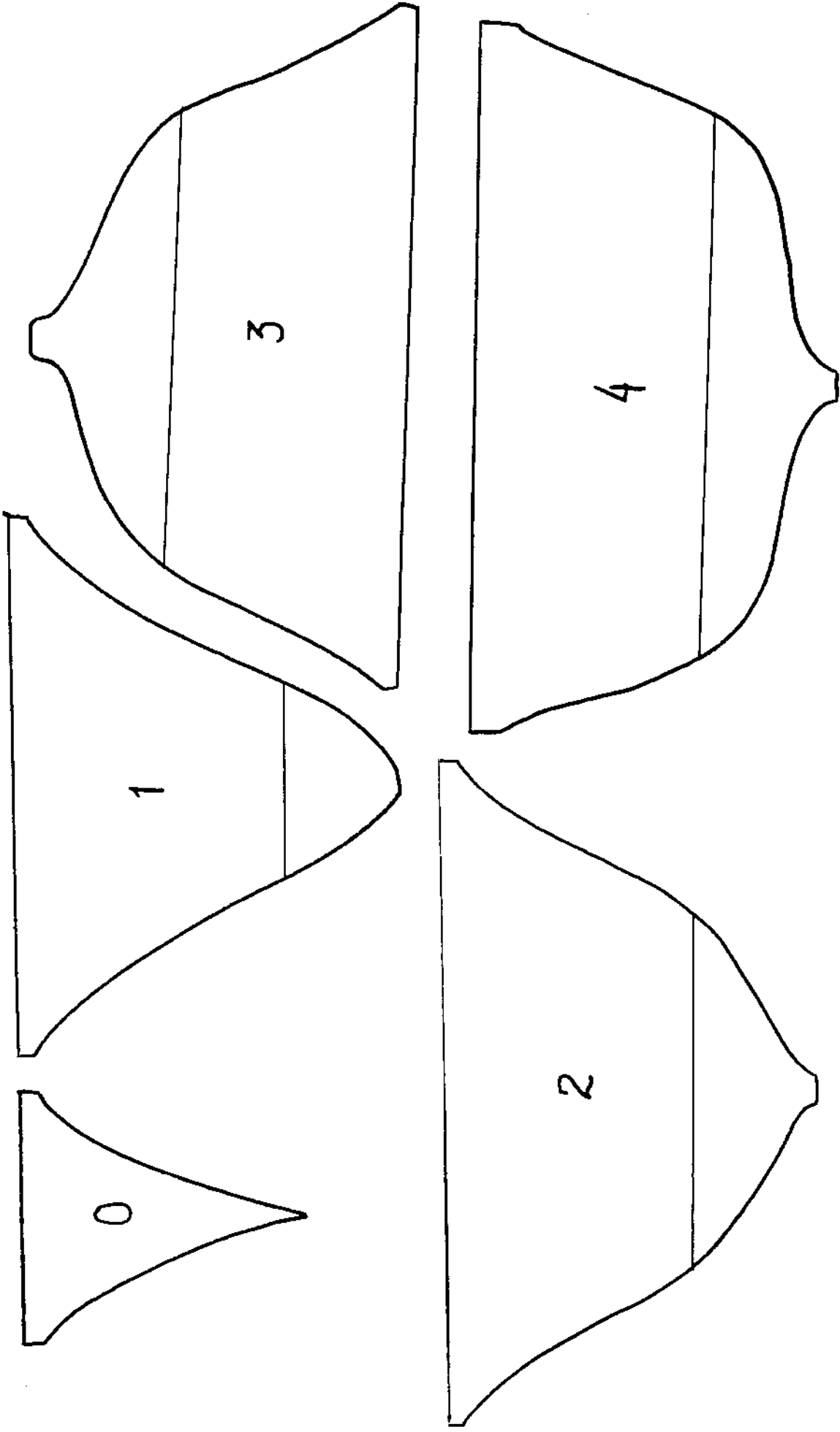

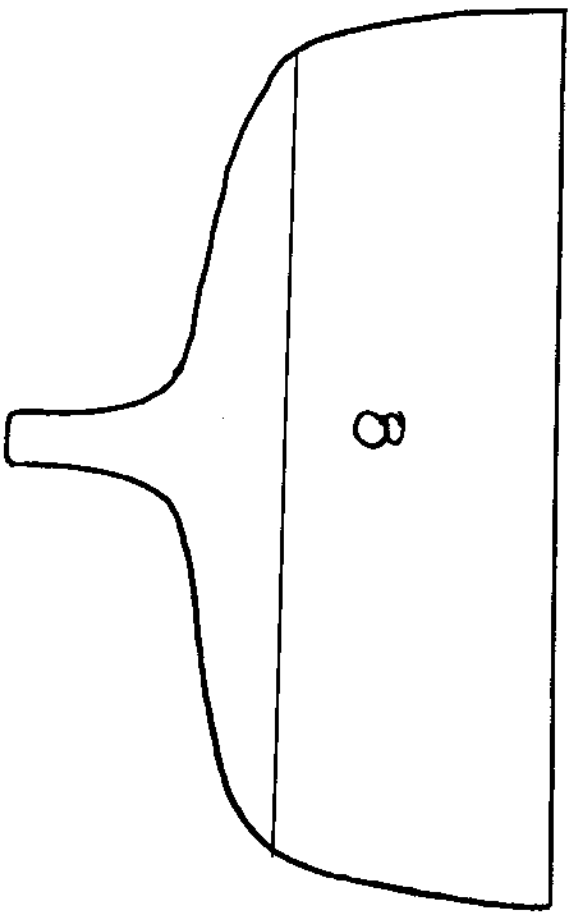
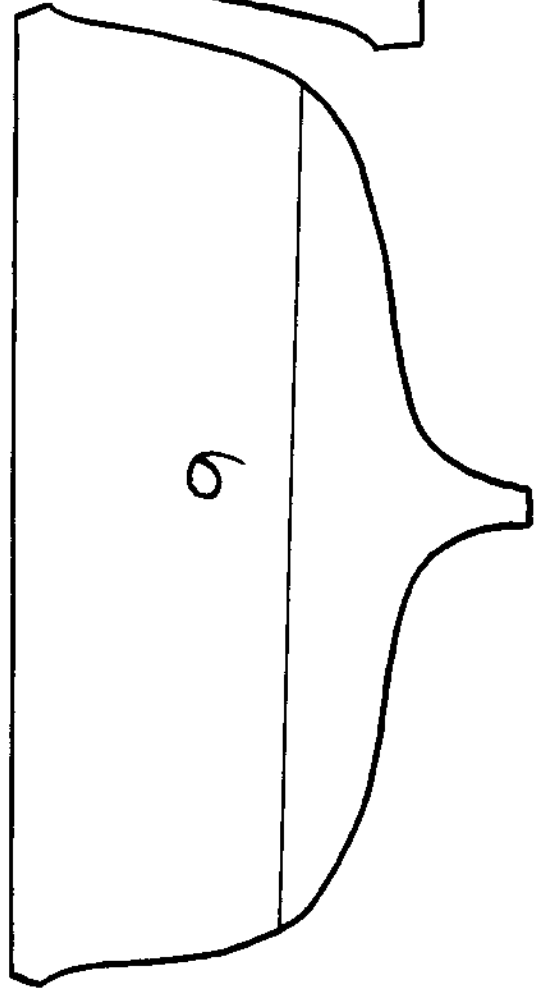
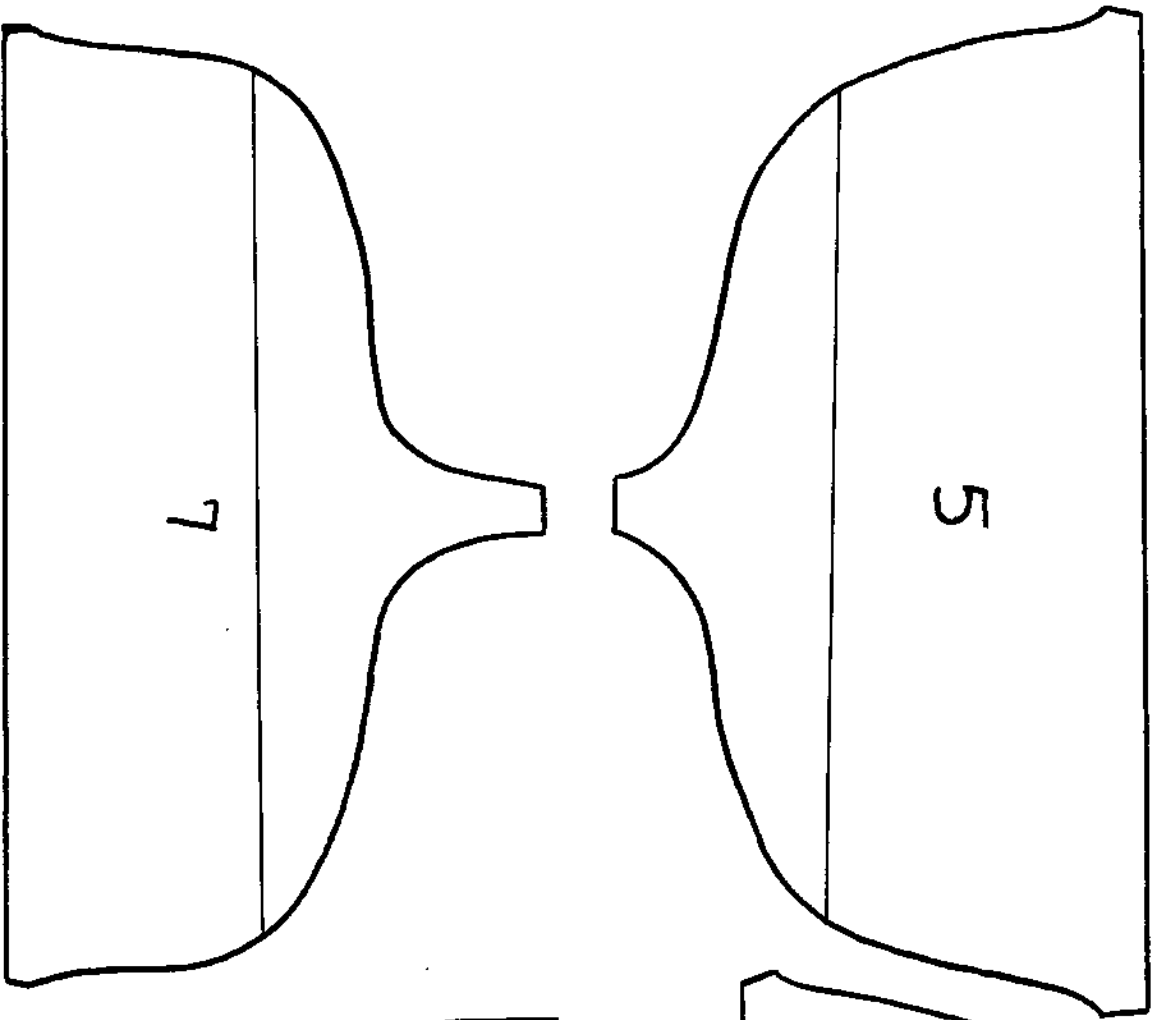

Lobster Boat, continued

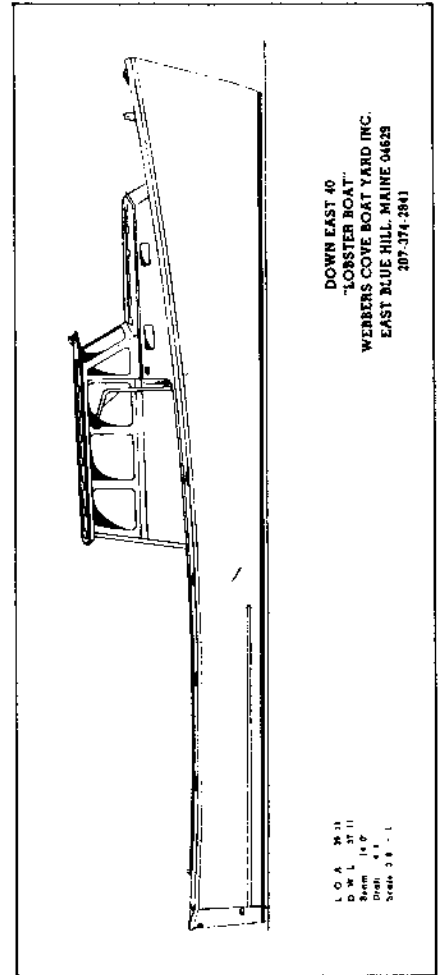
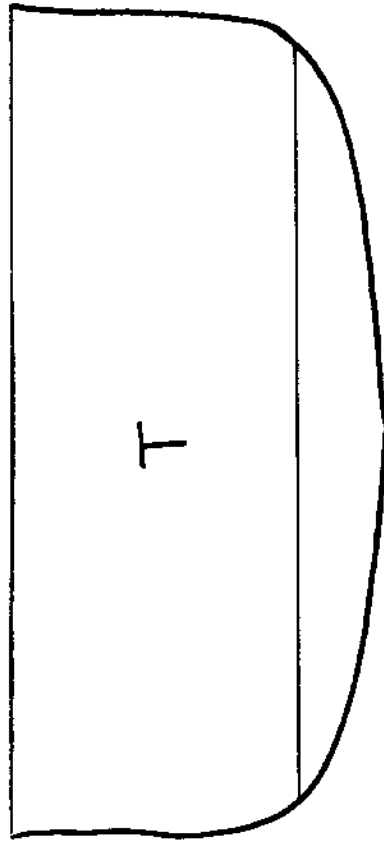
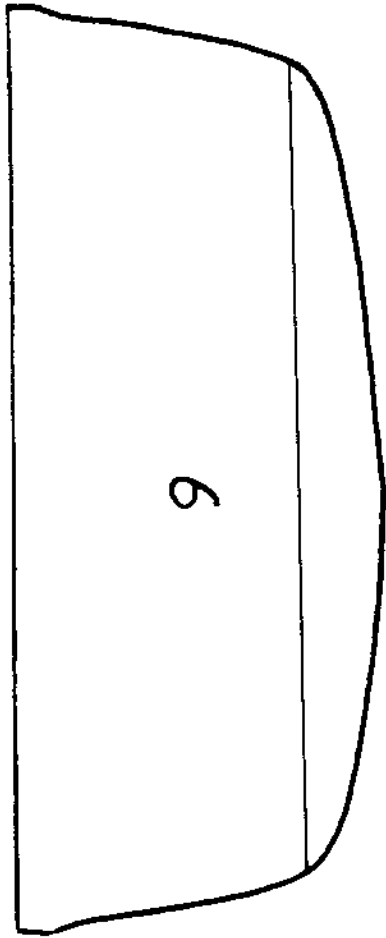

# RIO GRANDE

Very slowly

The musical score for 'RIO GRANDE' is written on five staves. The key signature has three flats (B-flat, E-flat, A-flat) and the time signature is 6/8. The tempo is 'Very slowly'. The score is divided into a 'Solo' section and a 'Chorus' section. The lyrics are: 'Oh were you ev-er in Ri—o Grande? A-way you Ri-o! Oh were you ev-er in— Ri—o Grande? I am bound to the Ri—o Grande. Then a—way you - Ri-o, A—way you Ri—o. Then fare you well, my pret—ty young girl— I'm bound to the Ri—o Grande'.

Solo Chorus

Oh were you ev-er in Ri—o Grande? A-way you Ri-

Solo Chorus

o—! Oh were you ev-er in— Ri—o Grande? I am

bound to the Ri—o Grande. Then a—way you - Ri-

o, A—way you Ri—o. Then fare you well, my

pret—ty young girl— I'm bound to the Ri—o Grande

# HAULIN' THE BOW LIN'

Moderately

The musical score for 'HAULIN' THE BOW LIN'' is written on two staves. The key signature has three flats (B-flat, E-flat, A-flat) and the time signature is common time (C). The tempo is 'Moderately'. The score is divided into a 'Solo' section and a 'Chorus' section. The lyrics are: 'Haul on the bow-lin', the fore and main-top bow—lin.' and 'Haul on the bow-lin', the bow—lin' Haul'.

Solo

Chorus

Haul on the bow-lin', the fore and main-top bow—lin.'

Haul on the bow-lin', the bow—lin' Haul

(shouted-grunted)

# Walking Beam Instructions

