

CIRCULATING COPY
Sea Grant Depository

LOAN COPY ONLY



Northern New England Marine Education Project

**NATIONAL SEA GRANT DEPOSITORY,
PELL LIBRARY BUILDING
URI, NARRAGANSETT BAY CAMPUS
NARRAGANSETT, RI 02882**

**How Do People Use
Lighthouses and
Navigational Charts?**

How Do People Use Lighthouses and Navigational Charts?

A Marine Education Infusion Unit

NATIONAL SEA GRANT DEPOSITORY
PELL LIBRARY BUILDING
URI, NARRAGANSETT BAY CAMPUS
NARRAGANSETT, RI 02882

Units Revision Team

John W. Butzow, *Project Director*
Peter Corcoran, *Curriculum Writer
and Assistant Director*
Susan White, *Educational Materials
Design and Production*
Rick Hardman, *Illustration*

Copyright© 1980 by the University of Maine at Orono.

Permission is hereby granted to classroom teachers and informal educators to make unlimited numbers of copies of any portions of this material for classroom or teacher education uses.

All other rights reserved. For additional permissions write to the Northern New England Marine Education Project, 206 Shibles Hall, University of Maine, Orono, Maine 04469.

Acknowledgement of Support

The original editions of these units were supported by the College of Education and the Maine-New Hampshire Sea Grant College with funding from the Office of Sea Grant, NOAA, U.S. Department of Commerce.

This edition is based on work supported by the National Science Foundation under Grant No. SER8008177.

Any opinions, findings, and conclusions or recommendations expressed in this publication are those of the authors and do not necessarily reflect the views of the National Science Foundation.

Contributors

NNEMEP Staff

Project Director: John Butzow 1975-81

Project Assistant Directors:

Richard Schlenker 1976-77

Les Picker 1977-78

Harry H. Dresser 1978-79

Peter Corcoran 1979-81

Major Contributors:

John Butzow
Clayton Carkin
Peter Corcoran
Victor DeSilvestro
Harry Dresser
John Eiseman
Richard Glueck
Ruth Gruninger
Richard Hansen
Deborah Hartney
Wesley Hedlund
Mildred Jones
Win Kelley
Steven Kilfoyle
Daniel Lancor
Jean MacConnell
Julia Steed Mawson
Chris Morgner
Les Picker
Robert Pratt
Gail Shelton
Lorraine Stubbs

Staff Assistants:

Julie Brown
Deborah Hartney
Michael Shirley

Developmental Art Work:

Peter Archambault
Lori Dombek
Carol Nichols
Harry Dresser
William Hepburn

Developmental Photography:

Les Picker
John Butzow
Clarence Barber

Manuscript Preparation:

Mary Brown

Revised Marine Education Infusion Units for Middle School-Junior High School

Have You Been to the Shore Before? A Marine
Education Infusion Unit on Seashore and Aquarium
Life

***What Adventures Can You Have in Wetlands,
Lakes, Ponds and Puddles?*** A Marine Education
Infusion Unit on Wet Environments

What is Our Maritime Heritage? A Marine Education
Infusion Unit on Ships and Shipping

Is Our Food Future in the Sea? A Marine Education
Infusion Unit on Aquaculture and Sea Farming

***How Do People Use Lighthouses and Navigational
Charts?*** A Marine Education Infusion Unit

Original — Trial Editions (For Grades K-12)

Clams and Other Critters

Marine Art

The Aquarium

The Beaver

The Lobster

Whale Multi-disciplinary Studies

Our Heritage of Ships

Shipping, Ships and Waterways

*The ABCs of Celebrating Year of the Coast in
Your School*

Have You Ever Been to the Shore Before?

Blue Mussel

Lighthouses

Wetlands

Seaweeds

Aquaculture

Navigation

More than one hundred teachers and members of past NSF sponsored summer institutes have trial tested and critiqued these units.

Marine Education

Ocean & Coast Conceptual Scheme

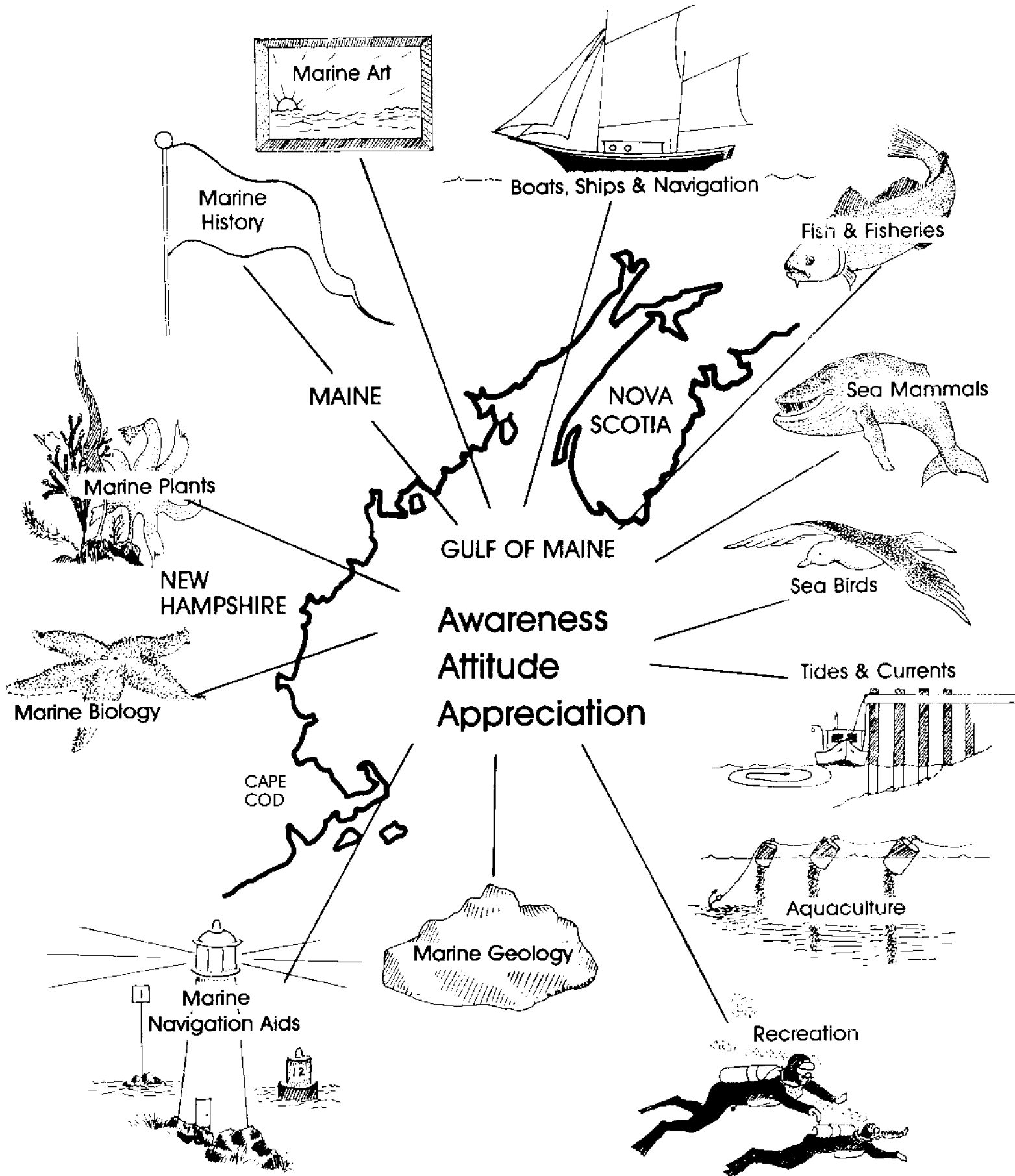

Foreword

Marine education is a relatively new term embracing a multi-disciplinary approach to learning about the marine environment: how it relates to people and how people change and relate to it. These units are intended to serve as points of departure for teachers and students who desire to increase their awareness of the watery world of this blue planet. Each unit includes ideas and activities drawn from a variety of content areas so that teachers of many different subjects at the junior high and middle school levels can make use of them. These units may be used in their entirety or used as idea or activity sources to infuse into the usual curriculum.

Our objective is to help teachers make learning more water-related. We did not plan a structural sequence of topics for grades 5-9 but rather offer these teachers guides and student pages for your consideration.

The general focus within these units is the Gulf of Maine. As the Gulf extends from Cape Cod to Nova Scotia it washes an extremely long and varied coast. We have dredged and seined themes from the activities, concerns, organisms, vessels, and the past of this vast watery region of North America. We aim to be inclusive rather than exclusive, suggestive rather than factual, and stimulating rather than expert. Our hope is that your students will become more questioning, interested, and critical of watery concerns. We hope your use of these materials will add water back into our culture.

John W. Butzow

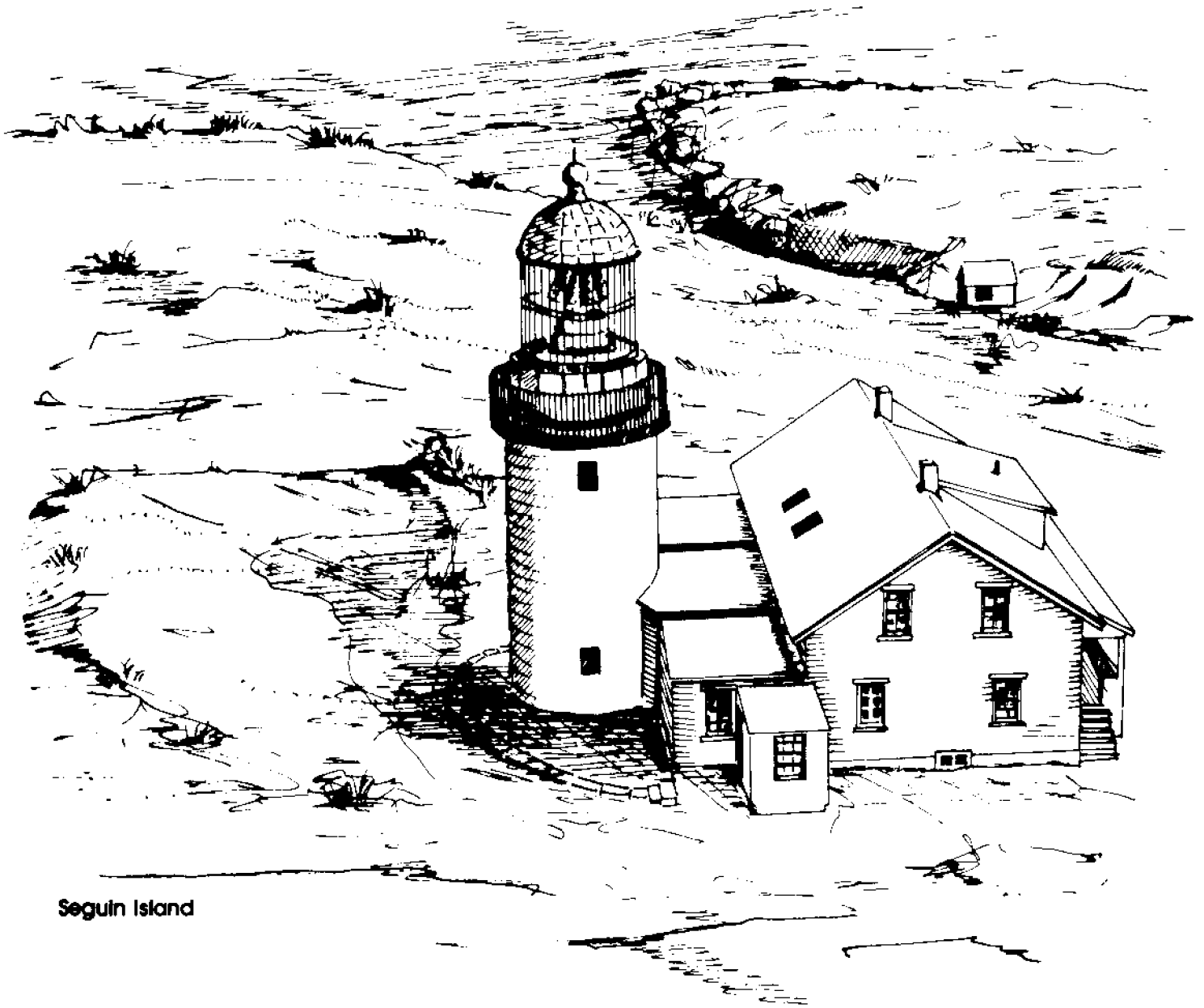

Seguin Island

A Note on Measures and Genders

Navigators still employ customary units such as feet and yards. In addition navigators use nautical miles for distances. This unit also uses conventional and navigators' distances instead of metric units with marine charts. We encourage metric units, however, in activities in which actual measurements are made by students.

A number of occupational words have as yet no generally used non-sexist equivalent. We have therefore retained use of the terms fisherman and lobsterman for either sex.

Contents of the Teacher's Guide

Teacher Background Information

| | |
|--|---|
| An Introduction to Marine Charts | 1 |
| An Introduction to Navigational Aids | 3 |
| An Introduction to Lighthouses | 4 |
| An Introduction to Navigation | 6 |

Classroom Activities

| | |
|--|----|
| Lighthouse Characteristics and Chart Symbols | 9 |
| An Interview with Roscoe Fletcher | 9 |
| Reading the Book <i>Abbie Burgess</i> | 13 |
| Writing Lighthouse Poetry | 15 |
| Log Writing Exercise | 17 |
| Lighthouse Projects | 17 |
| Navigating from Lighthouses | 18 |
| Bearings | 18 |
| Dead Reckoning Problems | 21 |
| A Cobscook Bay Plotting Problem | 21 |
| Outdoor Navigation | 22 |
| The Lighthouse Puzzle | 23 |
| The Challenge of Head Harbor Passage | 23 |
| Quadrants | 24 |
| Determining Latitude and Longitude | 25 |

Teacher Resources

| | |
|---------------------|----|
| Marine Charts | 27 |
|---------------------|----|

Annotated Bibliography

| | |
|-------------------|----|
| Lighthouses | 29 |
| Navigation | 30 |

Places to Visit

| | |
|-------------------|----|
| Lighthouses | 33 |
| Museums | 33 |

Contents of the Pocket

| |
|--|
| Chart Numbering System of the Gulf of Maine |
| Chart Section "Portland Harbor" |
| Chart Section "West Cod Ledge" |
| Tide Table |
| Simplified chart, "Cape Elizabeth to Matinicus Rock" |
| Fictitious Chart, "Orono Bay" |

Chart Section, "Head Harbor Passage"

A Folio of Lighthouse Sketches

1. Petit Manan
2. Fresnel Lens from Petit Manan
3. Matinicus Rock Light Station
4. Boathouse and Ways at Matinicus Rock
5. Light and Radio Beacon at Matinicus Rock
6. Pemaquid Point Light
7. Halfway Rock Light
8. Portland Head Light
9. Old Fashioned Rotating Light

Chart Section, "Cobscook Bay"

Chart Section, "Puzzle Chart"

Coast Outline for Head Harbor Passage

Teacher Background Information

There is no better way to become familiar with the sea than to spend time aboard a vessel. That reality is beyond the means of many schools today, so this unit was designed to help students learn vicariously about the shape of the sea, its coast and contours, through the study of navigational charts — the maps of the sea. In addition, navigational aids — the road signs of the sea — are a major part of this unit.

The single most important aid, the lighthouse, occupies a primary position in this study along with the people who operate them. In the present, many lighthouses and other lighted aids are operated automatically. In the last century, and even as recently as thirty years ago, it was personal heroism that often allowed these important aids to function during adverse conditions. Roscoe Fletcher, a keeper of this century and Abbie Burgess of the last century are featured personalities in this unit.

Navigational aids both serve to warn against danger and help the mariner locate his or her position in a sightless water wilderness. Experiences with dead reckoning are included to provide students with practical uses for charts, protractors, and compasses as well as to help them gain a sense of place on the surface of the sea.

An Introduction to Marine Charts

Marine charts provide the same sort of picture of the surface of the earth that land maps do with one important distinction. The sea's surface level is highly irregular and is influenced by tides. Submerged and harmless rocks, shoals, and wrecks at one tide may come dangerously near the surface or even break through on another tide. The soundings provided are for mean low water and are given in feet or on larger charts in fathoms (1 fathom = 6 feet).

There is not enough room in this guide to include a great many actual chart sections although several are provided as examples. You are encouraged to purchase at least one full chart for classroom study. Information on purchase of marine charts is given in "Teacher Resources."

You are now invited to try a chart reading exercise. You may later wish to use this exercise to familiarize your students with marine charts. In this practice example, "Portland Harbor" and Chart 13292 will be the focus. A section of the chart and a page from *Tide Tables 1981* (captioned: Portland, Maine, 1981) are provided for your convenience in the pocket. Please place them before you.

Let us assume that you were making an approach to Portland from the south and have a present position just below Jordan Reef, in 59 feet of water. You will find this in the lower right hand corner of the chart. Follow into Portland Harbor

via the water off the tip of Cushing Island and beyond between House Island and Spring Point. The following passage from the *United States Coast Pilot: Eastport to Cape Cod (1981)*, p. 180 describes what you are seeing.

Portland Southern Approach

A stone tower about 0.5 miles southward of Portland Head Light is conspicuous as is **Chimney Rock** about 300 yards southeastward of the tower.

Portland Head Light, 101 feet above the water, shown from an 80-foot white conical tower connected to a dwelling, marks the south side of the entrance. A fog signal is at the light. A directional light, 23 feet above the water, is shown from the same structure.

Ram Island Ledge Light, 77 feet above the water, shown from a light gray conical, granite tower, is on the ledge, awash at low water, about 400 yards south of 27-foot-high **Ram Island**, and marks the north side of the entrance; a fog signal is at the light.

Cushing Island, on the northeast side of the entrance, is mostly grass covered. **White Head** is a bluff at its northeastern end. A pier is in Spring Cove on the north side.

Two old observation towers on the island are conspicuous. One is on **White Head** at the northeast side of the island; another is 500 yards southwestward of it.

House Island, also on the east side of the main channel, northwestward of Cushing Island,

is the site of the abandoned quarantine station. **Old Fort Scammel** on the southwest end is conspicuous, and the summit of the northeastern part of the island is marked by a house and flagpole. **House Island Light 3**, 23 feet above the water on a white skeleton tower with a small house, is on the north end of the island, and **Fort Scammel Point Light**, 35 feet above the water on a skeleton tower with small white house, is on the south end.

Spring Point is on the west side of the channel about 1.8 miles northwest of Portland Head Light. The buildings at **Fort Preble** on and southward of the point are conspicuous. A breakwater on the ledge which extends about 300 yards northeastward of Spring Point is marked at the end by **Spring Point Ledge Light**, 54 feet above the water, shown from a white conical tower on a black cylindrical pier. A fog signal is at the light.

Fort Gorges, a conspicuous gray stone structure, is on **Diamond Island Ledge**, 0.8 mile northwestward of House Island. The ledge has a large area which uncovers, and a few spots bare at high water. **Diamond Island Ledge Light 6** marks the west end of the ledge. The south and east side of the ledge are marked by buoys. The wreck of a six-masted schooner about 700 yards 018° from Fort Gorges is no longer visible.

On the bluff above and westward of Fish Point on the north side of the entrance is the city of Portland. There are numerous conspicuous landmarks on the bluff and in the city, most of which are charted. One of the most conspicuous and historical is the old observatory tower which resembles a lighthouse. The microwave towers on the telephone building are very conspicuous.

As you enjoy your imaginary visit to Portland you will encounter various abbreviations which are listed below.

Lights (Lights are white unless otherwise indicated)

| | | | | | | | |
|----|----------|------|-------------------|------|----------------|-----|----------|
| F | fixed | Mo | morse code | OBSC | obscured | Rot | rotating |
| Fl | flashing | Occ | occulting | WHIS | whistle | SEC | sector |
| Qk | quick | Alt | alternating | DIA | diaphone | m | minutes |
| Gp | group | I Qk | interrupted quick | M | nautical miles | sec | seconds |

Buoys:

| | | | | | |
|----|----------------|---|--------|----|--------|
| TB | temporary buoy | N | nut | B | black |
| C | can | G | green | Or | orange |
| W | white | S | spar | R | red |
| | | Y | yellow | | |

Bottom characteristics:

| | | | | | | | |
|------|--------|----|--------|-----|--------|----|--------|
| Cl | clay | M | mud | hrd | hard | bk | black |
| Co | coral | Rk | rock | rky | rocky | br | brown |
| G | gravel | S | sand | sft | soft | bu | blue |
| Grss | grass | Sh | shells | stk | sticky | gn | green |
| gr | gray | rd | red | wh | white | yl | yellow |

| | | | | | |
|------|--------------|------|---------------------|-----|---------------------|
| AERO | aeronautical | R Bn | radiobeacon | CG | Coast Guard station |
| Bn | day beacon | R TR | radio tower station | DFS | distance finding |

Assume that the day is July 1, 1981 and that your vessel is standing in a place marked 16 or 16 feet depth of water. Using nautical time — a 24 hour clock — at 4:09 a.m. (0409) the actual water depth is (16 ft - 1.7 ft) or 14.3 ft. If your vessel draws 4 feet you are in good shape; however, if your vessel draws 15 feet you have enormous troubles. Similarly at 10:22 a.m. (1022) the depth is 25.6 feet. Again at 4:19 p.m. (1619) the water depth decreases to 15.4 feet and finally in the late evening it becomes 27.2 feet at 2234 (10:34 p.m.). As you convert time from nautical time to landlubber time, subtract 1200 from those times greater than 1200 and then insert a colon two digits from the right. The tidal datum from the tide table is algebraically added to the depth listed on the chart.

Direction is provided on the chart with reference to a compass rose. In the Portland area, as is typical of many places on the earth's surface, the magnetic compass needle does not point towards the north pole, exactly. As is shown in the lines of force diagram, the earth's magnetic field projects outward in space creating direction distortions on readings for the northern part of the northern hemisphere and the southern part of the southern hemisphere. In addition, the apparent location of the magnetic pole shifts slightly year to year.

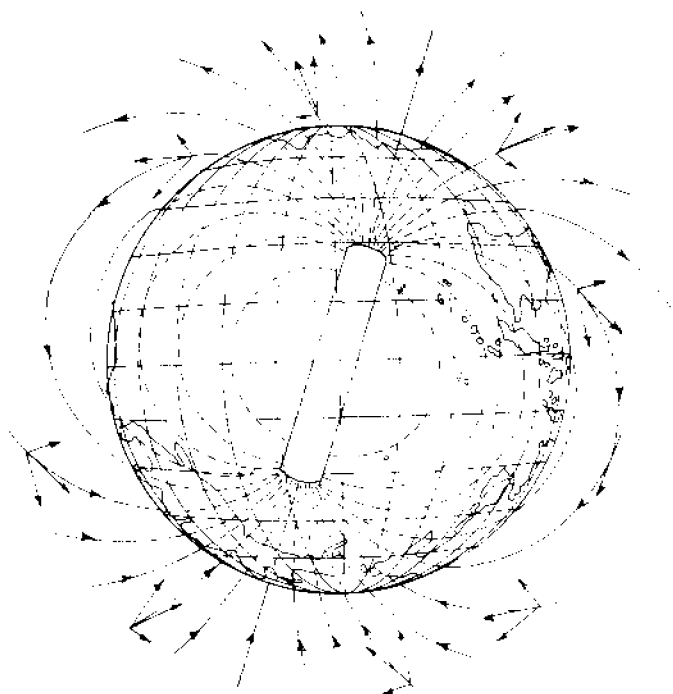

Lines of Force

Nautical charts are generally made so that true north is at the top and true south is at the bottom of the chart. True west is at the left and true east is at the right of the chart.

As is shown on the compass rose, magnetic north in the Portland area is 16°30' west of true north. For each year after 1977 there is a decrease of 2'. So, in 1982, the difference between magnetic and true is determined by (1982-1977 = 5 years) and 5 x 2' = 10'. The final difference becomes

16°20'W. This is too small a difference to be read on most school protractors and we will simply use the 1977 datum.

Compass readings are listed in full 360° to a circle values. All values are given to 3 digits of degree so that East or 90° is listed as 090. If your compass shows a reading of 000 or 360 north, the actual or true direction is (360-016°30') or (359°60'-016°30') or 343°60' slightly west of north. This value is about the same throughout our region.



Compass Rose

Latitude and longitude (l and lo) are hard to read from the chart section of 13292, called "Portland Harbor." Please look in the pocket for the section called "West Cod Ledge." This is the southeastern corner of chart 13292. As you look along the up or vertical edge of the chart you see lines of latitude or parallels. The distance between parallels is constant so that one nautical mile is defined as 1' (one minute) of arc. One nautical mile is 6,076.12 feet, 1.15 statute miles, 1,852 meters or 1.852 kilometers. A knot is a rate of speed equal to one nautical mile per hour. Knots and nautical miles are not interchangeable terms.

As you look along the horizontal edge of the chart you will find lines of longitude measured west from Greenwich, England. At our latitude, lines of longitude are not spaced so that they are 1' of arc for each nautical mile. If you are measuring distances with dividers or by simply marking dots on the edge of a piece of paper or envelope, remember to compare them to the vertical edge of the chart. Using our two pieces of the Portland Harbor Chart, you might verify that the distance

from Portland Head to the northeast end of the House Island is about 2 nautical miles.

These nautical charts are Mercator Projections and as such do not represent the east-west distance equally with the north-south direction. Because of this problem the distances on the surface of the chart are slightly distorted and a chart-based measurement is only an estimate.

An Introduction to Navigational Aids

There are many aids to the navigator. The principal ones are buoys some of which are lighted. The symbol for a buoy is:



A buoy that is lighted either has a circle around its base or a parachute shaped light symbol radiating from it.



or



Buoys can be various colors, the most standard are:

| | |
|--------|----|
| white | W |
| black | B |
| red | R |
| yellow | Y |
| green | G |
| brown | Br |
| blue | Bu |
| orange | Or |

A Buoy  RB is red and black.

Buoys which mark harbor approaches are usually striped and numbered. This is a buoy which is conical shaped and painted red.

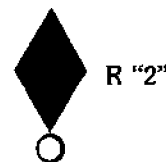

R "2"

Nuns are typically even numbered. The rules of the road usually require navigators to keep nuns to their starboard (right) side when returning from seaward. Hence the rule, "red right return."

Black cylindrical shaped buoys are called cans.

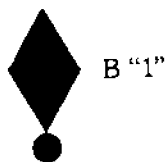

Cans are odd numbered and are kept on the left or port side. These rules keep the vessel in the proper channel.

Where a permanent obstruction such as a rock is marked, it often is marked with a small unlighted tower with a reflector attached. These structures are called daybeacons and are symbolized as R, for a red one.

Occasionally fog signals are parts of the buoys. These can be bells, whistles, chimes, gongs, or horns. Some are on for a specific number of times per second and this information is listed next to the buoy containing the signal.

Lighted buoys may be various colors and have various relationships in how long they are off or on. Their characteristics are the same as lighthouses and are discussed in the next section.

A complete listing of chart symbols and their meanings is found in *Chart 1: Nautical Chart Symbols and Abbreviations*. This reference is listed in the "Teacher Resources" section. It is strongly recommended that you purchase a copy for your classroom.

An Introduction to Lighthouses

There are more than sixty principal lights along our coast between Portsmouth, New Hampshire, and Lubec, Maine. This light at West Quoddy Head is on the easternmost point of land in the continental United States. Portland Head Light, the most photographed of American lighthouses, was commissioned by George Washington in 1787, while Maine was still part of Massachusetts. She was the first of the lighthouses along the Maine coast. The Portland masons who built Portland Head Light from local materials completed the light in 1790. It was first lighted on January 10, 1791. New Castle Light in Portsmouth Harbor was originally built during colonial times.

Lighthouses are used by mariners to determine their positions at night and during times of reduced visibility so that they can keep their vessels out of danger. Lighthouse structures can be tall, cylindrical towers reaching as high as 180 feet above sea level, like Seguin Island Light. They may be wooden-frame structures less than 30 feet tall, such as the light on the Graves outside Camden Harbor.

Light intensities vary considerably depending on the job the light is expected to do. Small lights located along river banks are often fixed lights with ranges of visibility as short as five or six miles. Fixed means that these lights don't blink, but are on continually. These small lights are often erected on small wooden or steel towers. Red or white lights will be found along the right side of rivers and channels, as you enter from seaward, and green or white lights will be found along the left



West Quoddy Head

side. These lights enable ships' pilots to direct their boats safely up the river.

Harbor lights are used by navigators to direct their vessels into harbors after dark. These lights take the shapes we usually think of when we think of lighthouses. Their heights and light intensities make these generally visible for about twelve to fifteen miles in good weather.

The taller, brighter lighthouses found on outer islands and prominent points are ocean lighthouses and are used by navigators to fix their positions as they approach land from the open sea. These lights are often visible for more than twenty miles in clear weather, and often have radio beacons to further help ships' navigators.

Lighthouses in the past were always manned by keepers and assistant keepers. In some cases, the keepers and assistant keepers had their families with them, and in other cases, the lights were manned by men only. Light stations occupied by entire families became known as "family lights," while those kept by a group of men became known as "stag lights." Today, many lights are "automatic;" that is, they are turned on and off electrically and have no permanent personnel living on them. These lights are checked periodically by Coast Guard personnel, and are checked immediately when someone reports they are malfunctioning.

There are currently about eighteen inhabited light stations on our coast plus a manned loran station and an inhabited fog signal station. Of these stations, about a dozen are family stations with one or more families living at the station.

Inhabited Light and Fog Signal Stations (circa 1980)*

FAMILY LIGHTS

| | |
|----------------------------|------------------|
| Bear Island Light | Northeast Harbor |
| Browns Head Light | Vinalhaven |
| Fort Point Light | Stockton Springs |
| Owls Head Light | |
| White Head Light | Sprucehead |
| Burnt Island | Boothbay Harbor |
| Squirrel Point Light | Phippsburg |
| Doubling Point Range Light | Bath |
| Portland Head Light | Cape Elizabeth |
| Wood Island Light | Biddeford Pool |
| Goat Island Light | Cape Porpoise |
| Cape Neddick Light | York Beach |

STAG LIGHTS

| | |
|-------------------------|---------------------------|
| West Quoddy Head Light | Lubec |
| Great Duck Island Light | Great Duck Island |
| Heron Neck Light | Vinalhaven (Green Island) |
| Matinicus Rock Light | Matinicus Rock |
| Seguin Island Light | Seguin Island |
| Isles of Shoals Light | New Castle, New Hampshire |

OTHERS

| | |
|--------------------------|---------------|
| Manana Island Fog Signal | Manana Island |
|--------------------------|---------------|

* The number of inhabited stations decreases every year with planned automation.

In the pocket, find an artist-drawn chart section called "Cape Elizabeth to Matinicus Rock" of chart number 13009; you will be able to see the location of Matinicus Rock Light where Abbie Burgess lived. Some features of the mainland shore, several other lighthouses, some other navigational aids, and a compass rose have also been included on this chart. The abbreviated information associated with the lighthouses on the chart tells you a great deal about the lights. In order to make the lights readily identifiable to sailors at night, each light has a characteristic light pattern unlike other lights in the area. The first information about the light explains that characteristic. GpFl, as found on the Matinicus Rock Light, means group flashing. This is followed by (1 + 2) 15 sec., which means that Matinicus Rock Light flashes once, pauses and then flashes twice. It goes through this pattern once every fifteen seconds.

Fl, as found on Monhegan Island Light, Pemaquid Neck Light, Halfway Rock Light, and Portland Light Buoy means flashing. The time interval which follows the Fl indicates the period of darkness between flashes. So, Monhegan Island Light flashes once every 30 seconds.

The F found on Seguin Island Light means fixed. This indicates that the light is illuminated continually. These various light characteristics help sailors positively identify the lights they are looking at during nights and periods of reduced visibility. This is necessary for a number of reasons. Entering Portland Harbor, for example, on a clear night five or six different lighthouses can be seen at the same time.

Following the flash interval in the light information, the height of the light above sea level is given followed by the geographic range of visibility of the light. This is expressed in nautical miles. The range is the distance the light can be seen in clear weather. This distance is determined using the height of the tower above sea level and the intensity of the light. Of course, in periods of reduced visibility due to fog or precipitation, the range at which the lights can be seen is greatly reduced.

Some of the lights on your chart have the symbol R Bn associated with them. This means that they have a radio beacon operating at the site. The number following the R Bn shows the frequency which the signal may be found at on the ship's radio direction finder. This value is expressed in thousands of cycles per second (kHz). Radio beacons allow ships and boats with radio receivers to establish their positions over fairly long distances using their transmissions. The dots and dashes on the chart indicate the characteristic signal sent by the radio beacons. Each beacon has its own characteristic signal just as each light has its own light pattern. The Matinicus Rock Beacon sounds morse code letters M and R (... ..) for about 45 seconds of its minute of operation followed by a continuous tone of about 10-15 seconds. Each of the radio beacons in

the Gulf of Maine sequence operates for one minute out of every six minutes.

The type of fog signal to be heard at each of the lighthouses is also listed in the chart. Each of those on your chart has a horn, but others have bells, whistles, gongs, or sirens.

An Introduction to Navigation

Navigation is the science and art of finding place location and forecasting locations. It depends in part on chart use and compass coordination and in part on relating position on earth against the positions of heavenly bodies. In this section we will be discussing bearings, dead reckoning, and latitude and longitude determination.

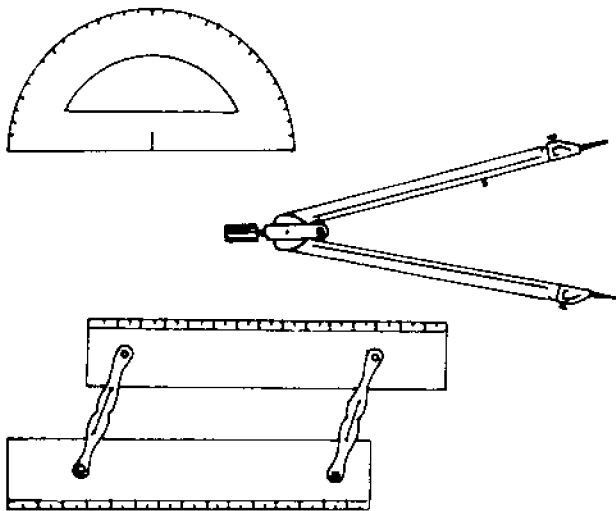

Bearings

A basic piloting skill utilized by navigators of all sized vessels is the taking of bearings on objects with known locations. Taking several nearly simultaneous bearings on different objects and plotting them can result in a fix, which is a reasonably certain plot of your position at that time.

A bearing is taken by noting the direction from you to the object using a compass. Several devices such as the hand bearing compass and pelorus have been developed for taking accurate bearings, but any compass will do.

Teaching students about bearings presents a good opportunity to discuss directional reciprocals, since you will plot the reciprocal of the true bearing (TB) from the object toward your position. A reciprocal is 360° minus the angle from the object to you.

In this plotting from the known position toward the approximate position of the boat, we are drawing a line of position (LOP). We know that our boat is somewhere along that LOP if we have taken the bearing correctly. By plotting two or more of these bearings, a fix can be established at the intersection of the LOP's. When plotting an LOP write the bearing on the object above the line and the time of the bearing below the line.

Dead Reckoning

Dead, or deduced, reckoning is the most basic of the navigational practices. It involves simply accounting for the speed, direction, and length of time of travel of your vessel to arrive at your deduced position. This position is commonly called the DR position of the vessel and is kept by all navigators. Practically, the navigator keeps track of speed, direction, and length of time of travel from a known position called a fix. In the examples we use in our exercises, the fix will be established by close proximity of the ship to a known navigational aid or land feature.

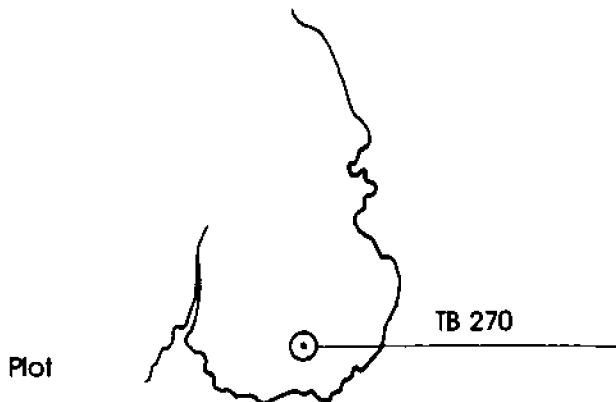
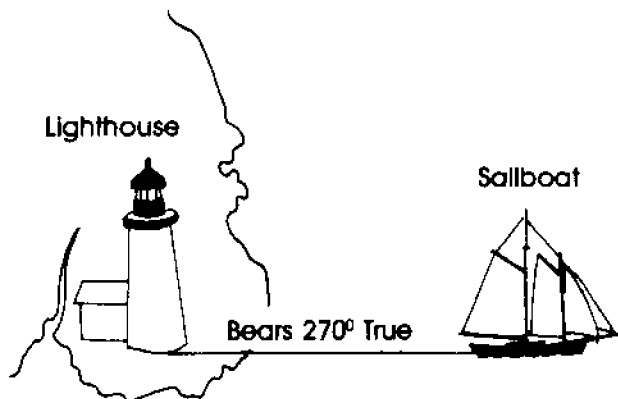

Algebra students will have little trouble dealing with the navigator's distance, rate, and time formula. For most inshore navigation or pilotage, the navigator uses the formula $60D = ST$, since he/she is to be dealing with time expressed in minutes. It is clear that this represents only a minor adaptation to the standard distance, rate, and time formula ($D = RT$) commonly taught in school mathematics.

While using this material with your students, use true directions. That is, consider directions of travel as being measured clockwise from true North. True North is easy to locate on a chart or map, since the meridians, or lines of longitude, run true North-South. To determine a true course on a chart, just measure the angle formed between a meridian and the course line. Measure this angle clockwise from North.

Speed

Speed is always expressed in knots, which are nautical miles per hour. You will sometimes hear people talk about knots per hour. This is incorrect usage, unless they happen to be talking about an acceleration, which is unlikely. One nautical mile = 1.15 statute miles. Nautical miles are particularly handy for navigators to work with since 1 nautical mile = 1' of latitude, which can be readily measured from the vertical margin of any chart. Fractions of nautical miles are reported in tenths. For example it is correct to write 1.4 nautical miles but not $1 \frac{4}{10}$ nautical miles.

Time

The maritime navigator utilizes hours, minutes, and seconds in distance computations. Pilotage work often necessitates the use of minutes alone.

The Process

The actual process of dead reckoning (DR) is quite simple. If we are close aboard buoy N "2" at 1300 proceeding on course of 090° TC at a speed of 9K, we can predict, or deduce, our position at subsequent times. For example, at 1400, one hour later, we will be 9 nautical miles east of N "2." That would be plotted in this manner on a chart.

Note that the true course (TC) is printed above the plotted course line and the speed (S) is printed below the course line. The times are labeled not parallel to any line. The 1300 position is labeled the

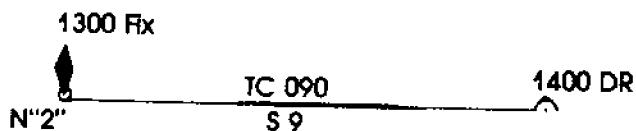

1300 fix, because our position is known since we're close to the buoy. The 1400 position is labeled 1400 DR since it was arrived at through dead reckoning.

Students can learn those simple conventions and then enjoy solving $60D = ST$ in order to locate various DR positions along the course line on real or fictitious charts.

The actual measuring of courses on the chart, or plotting of courses on the chart is done using some sort of course protractor, or parallel rules. Parallel rules are simply two rules attached to each other so that moving one will result in moving a line segment parallel to the line segment formed by the stationary leg. To plot a course, the desired course is found on the compass rose nearest your area and one edge of the parallel rules is laid down to intersect the center of the compass rose and the mark on the circle for the appropriate course. You'll notice that the outer ring of courses is true courses, while the inner ring consists of magnetic courses. The other rule is then moved toward the area in which you want to construct the course line. The parallel rules can be "stepped" across the chart in this manner until you are able to lay down your course line where you want it.

Course protractors are basically just elongated protractors. Some models include gadgets for corrections of variation and deviation, while others do not. Simple school protractors can be used readily, particularly when using true courses. Any meridian or parallel can be used as a base line for the use of a standard protractor. A rule along the edge of the protractor will make the edge of usable length. When using a parallel line of latitude, remember that your reference line runs east and west and this 90° shift from North must be accounted for in your measurement.

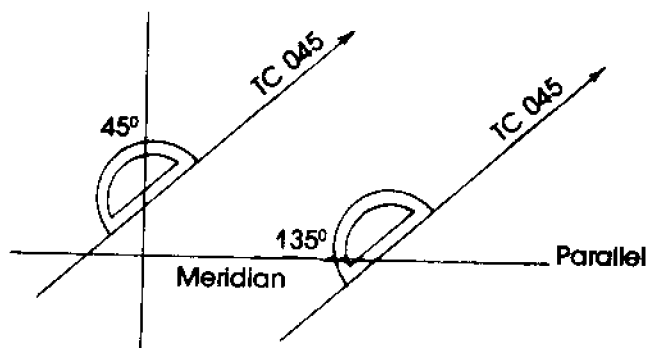

It is often necessary to determine deduced position (DR position) at times other than on the hour, or half hour. These positions can be arrived at through use of the equation, and usually are, but you might like to teach proportions from this frame of reference. For example, how far along the course line would we be in the previous example at 1425, at the same speed (9K)?

$$\frac{9}{60} = \frac{X}{25}$$

Determining Latitude and Longitude

Position at sea and on land in wilderness areas are often best described using the latitude and longitude coordinates of the position. If, for example, you wanted to report your location at sea to a friend in another boat so that he could rendezvous with you, you would locate your position on your chart, and report it to him by radio. To find the latitude and longitude coordinates of a point on the chart, simply construct perpendiculars from the point to the latitude and longitude scales on the margins of the chart. There you can read latitude and longitude to the nearest minute, or you can interpolate between minutes for increased accuracy.

For example, on the fictitious chart "Orono Bay," you will see that perpendiculars have been constructed from Snake Point Light to the scales on the margins of the chart. You can see that the latitude of Snake Point Light to the nearest minute is $44^{\circ}09'N$. Interpolating, you might call the latitude $44^{\circ}08.9'N$. The longitude measured along the bottom margin is $70^{\circ}14'$ to the nearest minute, while it is $70^{\circ}14.2'W$ if you interpolate.

This hypothetical chart depicts a location in the Northern Hemisphere. You could deduce this from the fact that latitude measure is increasing as you go north. On a chart of the Southern Hemisphere, the opposite would be true, that is, latitudes would increase numerically as you went south. Similarly, this chart represents an area west of the prime meridian as you can tell by the numerical increase in longitude as you proceed west.

No scale of distances is drawn on this chart so that students will learn to equate minutes of

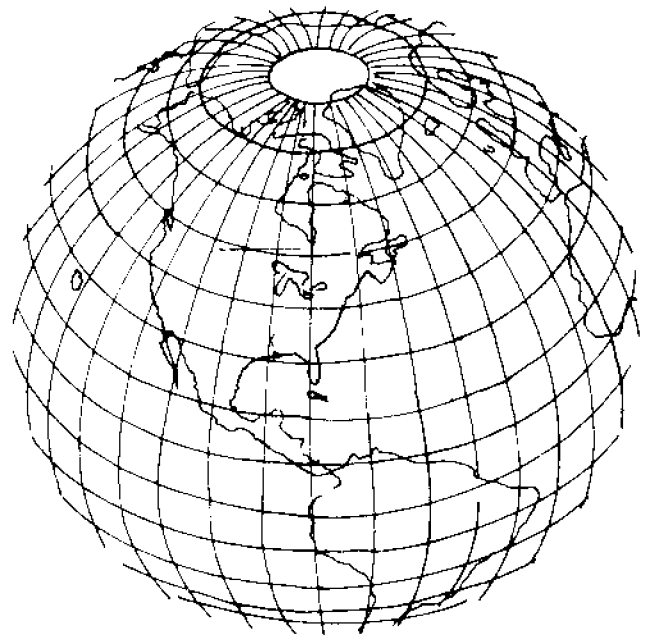

latitude with nautical miles. Do not allow them to equate minutes of longitude with nautical miles, since on the Mercator Projection chart, the minutes of longitude decrease in size relative to minutes of latitude as you go away from the equator. The only place that a minute of longitude would equal one nautical mile is at the equator. No compass rose is provided on the chart, but variation information is available in the upper left hand corner.



East Quoddy Head

Classroom Activities

Lighthouse Characteristics and Chart Symbols

This is intended as a familiarization exercise. While working with any actual full size chart is preferable, a section of chart 13328 called "Head Harbor Passage," is provided in the pocket for reproduction and use in this activity.

Introduce the basic symbols for buoys, lights, and daybeacons. As the activity continues, provide detail on lighthouse characteristics, and radio beacons when relevant. A good follow-up activity is to have groups of students make up location questions for other student groups.

Chart Familiarization Questions

Part I (Use only if you have a whole chart)

On your chart #13328, Calais to West Quoddy Head, find the following:

- The geographic region covered
- The type of projection and the scale
- The datum level for the soundings
- Tidal information
- Several compass roses
- Two scales
 - Miles/kilometers/yards
 - Fathoms/feet/meters
- The edition number, and date of publication
- LORAN lines and linear interpolators

Part II (Can be used with chart section, "Head Harbor Passage")

Find symbols for the following, and find examples on your chart:

- A nun buoy
- A can buoy
- A lighted red buoy
- A lighted black buoy
- A daybeacon
- An exposed rock, or ledge
- A bell buoy
- A whistle buoy
- A gong buoy
- A lighthouse
- The 30 foot curve (five fathom curve)
- A standpipe
- A radiobeacon

Determine the latitude and longitude of several landmarks, or buoys.



An Interview With Roscoe Fletcher

In the interview which follows, it is suggested that students take the roles of interviewer and interviewee. After classroom reading, students could summarize their notes and write a newspaper account as though they had actually interviewed Mr. Fletcher.

Roscoe Fletcher, accompanied by his wife, Dorothy, served on two remote lighthouses between the years 1929 and 1945. From 1929 to 1936 Mr. Fletcher was an assistant keeper of the lighthouse on Petit Manan. This lighthouse is located on a small island off Steuben and Milbridge,

in Washington County, Maine. In 1936, Mr. Fletcher was promoted to keeper and transferred to the light on Matinicus Rock.

Matinicus Rock is a small, barren island located about fifteen miles south of Vinalhaven and about twenty-two miles southwest of Rockland. It is about six miles from Matinicus Island. Matinicus Island is the place the Fletchers often went for groceries and their mail. Matinicus comes from the Indian word "manasquesicook" which means a collection of grassy islands.

Two assistant lighthouse keepers and their wives lived on Matinicus Rock with the Fletchers. The men's workday consisted of a 'normal' eight hour workday performing the necessary maintenance on the light and the station. The men would also stand watches on the light and the radiobeacon throughout the day and night. Each man stood two four hour watches a day. In a 1942 log book of the Matinicus Rock Light Station, one of the watch standers pencilled this poem about the keeper, Roscoe Fletcher.

Tale of Woe

(author unknown)

*On this lookout — four on and eight off I stand
Much rather would I be playing poker with
winning hands*

*The foghorns blow — they're driving me nuts
Yet old Fletcher says up the tower and no ifs,
ands, or buts.*

The Interview

RF: Roscoe Fletcher

I: Interviewer

DF: Dorothy Fletcher

I: Would you tell us who you are and where you live?

RF: Roscoe Fletcher, and I live in Lubec — North Lubec.

I: At one time were you keeper of several lighthouses?

RF: I was keeper of Matinicus Rock, and I was assistant keeper on Petit Manan before that.

I: When did you work at each of those lights?

RF: I went on Petit Manan in 1929 and was transferred to Matinicus Rock in 1936.

I: How long were you at Matinicus?

RF: Until 1945. I got hurt out there and they retired me in 1945.

I: Who was your employer while you worked on those lights?

RF: Well, I was under the Department of Commerce; in 1939 the Coast Guard took over the Lighthouse Service. I was under the Coast Guard and of course in wartime the Coast Guard went under the Navy.

I: Then, you were a civilian employee rather than a member of the Coast Guard?

RF: I was a civilian employee until the Coast Guard took it over in 1939 — even then, I didn't enlist right away. I don't remember what year I enlisted. In '40, '41 or '42, something like that.

I: Our readers are interested in this book *Abbie Burgess* and some of the things that happened to people who are living on an island that has a light on it. I thought maybe you could tell us something about the way your day went when you were a keeper — about what time you got up in the morning — what you did and so forth.

RF: Well, of course, we had normal duties to perform — keeping the light equipment in good working order and the fog signal and, of course, we had a constant watch on the radio beacon and the regular maintenance of the station equipment.

I: About what time would you normally take your first watch?

RF: Well, it was divided up into 4 on and 8 off. The watches was rotated every week. If I had the 4 to 8 this week I'd have the 8 to 12 next week.

I: Did you have an assistant on Matinicus Rock then that took...

RF: Two, two assistants that took the other watches.

I: How many lights were on Matinicus Rock at the time that you worked there?

RF: One.

I: Where there two towers?

RF: There were until, I think, it was 1911 when they discontinued the second tower. They were fixed lights. You know, every lighthouse has different characteristics. During the time they had two lights there were four keepers. They discontinued the north tower and made an occultating light of the other tower. I can't remember the characteristic now — so many seconds off and so many seconds on. I just can't remember that. If I had the chart, it'd give that on the chart.

I: What kind of light was it? Was oil burned in the light, or was it electric?

RF: Well, we called it an "I-O-V" light — that was Incandescent Oil Vapor. It had a mantle if I remember correctly. The mantle was a 35mm mantle and the kerosene was put in the tank — approximately 5 gallons. Then you pump that up to a certain pressure, whatever, 90 lbs or so and that went up into the vaporizer in the light and, of course, you had one light and you had to heat that with an alcohol torch — when it got the right temperature you turned the valve on a little bit and it came out in a vapor. You had to be very careful to keep the nozzles clean because they had a very small hole in them. The holes were smaller than a pin and that would come out in a vapor and go up into

that mantle and burn bright and, of course, the light had to be bright. From the lens, you see, if you get it too high or too low they wouldn't get the good bright light.

I: How many individual lights were there?

RF: One.

I: Was the light big?

RF: Well, you see, as I say, that was a 35mm. Now some of the lights had a candlepower rating and a different size lens — a first order, second order, third order, a fourth order lens. And Petit Manan, I think was a first order light and second order lens. I think that was 250,000 candlepower when it flashed. That was one of the bigger lenses.

I: How about Matinicus? What size was that?

RF: I think that was a third order lens.

I: How far could a navigator see those lights?

RF: It depended on the visibility. Sometimes you could see a light 80 to 90 miles. I've seen Petit Manan from down off of Yarmouth, Nova Scotia and that must be in the neighborhood of 90 miles. That's on very, very special occasions and when you could do that you could prepare yourself for a heavy storm. Visibility at sea level is twelve miles but, of course, at the height of the tower the visibility would be much greater. I don't remember reading what the visibility would be for any given light but as I told you, every light had a different characteristic. Years ago, when sailing vessels used to come in and make for shore, they'd pick up a light here, we'll say they pick up Mt. Desert Rock Light or Boon Island Light and they'd swing the ship and then get a compass bearing on that, you see, and they'd draw a line from the particular lights they were picking up and if they could they'd get a third bearing which would be over to Monhegan, to the west of Matinicus Rock and draw a line. Where those lines intersected was their position exactly. They knew where they were. And they could take it from there. That's running in from offshore you see. Later, radio beacons came into being and they didn't have to do that. They had a radio direction finder aboard the ship and they could get their bearings from them. And each one of the radio beacons transmitted a morse code letter and I think Matinicus Rock was "M" (dash-dash). I think it was, but it's been a long while.

I: What kind of a fog signal did you have?

RF: Diaphone.

I: Can you describe that for us?

RF: Well, I can describe anything you want. It was a diaphone and, of course, on those stations there was two of everything, if one happened to get temporarily out of order then you could turn the other one on while the other one was being set right again. And they would set on the tower outside the signal house. There were

two horns set in a Y arrangement. I think we had 30 to 40 pounds of air pressure on them. As I say, it's been a long time and I can't remember correctly.

I: What produced the air pressure?

RF: Diesel engines. They were horizontal, one cylinder, but there was a big twelve-inch distance and there was an air compressor in between the pistons and the crank shaft and they had the valves in the air compressor. And of course, I say, everything had to be kept clean. Overhaul the valves so they won't crack — we had spare parts.

I: Do you recall the characteristic of the Fog Signal?

RF: No, I don't.

I: Was it pretty loud?

RF: Yea.

I: Did anyone tell you having heard it from a very long distance from the rock?

RF: Well, I'm sure it could be heard twenty miles. That would be in certain kinds of weather conditions, you know. And there are places along all these stations that have fog signals that there is a blind spot. You get in just that spot for a minute or so and you can't hear it. That used to be so on Grand Manan and Quoddy Head. They were diaphones and they sounded light but now they've changed it — which is confusing, you see, they didn't know whether they were making north at Grand Manan or Quoddy Head. All those diaphones, when they'd end it with a MMMMMMMM... They changed Petit Manan Number 1 diaphone. Of course, most of those stations were steam in the beginning — steam boilers and steam whistles and when they changed them over they let the steam whistles remain and ran them by air. And I think they were ten-inch steam whistles which would give quite a signal. And later they changed them over to diaphones or whatever. I forget the name of the one they changed over at Petit Manan, it had two big discs as big as the stool you're sitting on. And they made quite a racket. Every once in a while one of those discs would crack. You'd get out there in a snowstorm and try to change one of them — it was miserable business.

I: Were these discs like symbols? And did they make a clanging sound?

RF: Well, vibration. And, of course, there was a horn out beyond that transmitted the signal. I don't think that proved satisfactory. I think they changed it.

I: How were you provisioned?

RF: We had to furnish our own. We got them as often as we could. As I said before, we never had any refrigeration in those days and we'd have to go ashore at least once a week to get fresh vegetables and fresh meats. We used to

catch fish, of course, and salt them, cure them. The old stand-by.

- I:** How about fresh water?
- RF:** It depended on the fresh water rainwater. We had cisterns in the basement of the houses and those cisterns had a partition in them and when one of those cisterns went dry, we'd scrub that all out good and when it rained again and filled up that we'd change the pipe over and you know the other one would go dry and we'd change the pipe over and clean the other one out. And sometimes it didn't rain enough — but we managed to get them cleaned out once a year. and sometimes we'd get a dry summer — and the lighthouse tenders would have to bring water to us.
- I:** Did you ever get salt in that water from bad storms?
- RF:** We never did on Petit Manan as I recall but on Matinicus Rock, you see, when it started raining we'd turn the cistern cups off as soon as it stopped raining so we wouldn't forget it. But when it started raining we'd let it rain for a while and wash the salt off the roof before we turned them on again. Sometimes the storm would bury the Rock.
- I:** You said "bury the Rock," what does that mean?
- RF:** In bad storms, waves could, at times, go right over the Rock.
- I:** Did water ever get into the lighthouse while you were on Matinicus Rock?
- RF:** No. On the windward side, the weather side of the assistants quarters, they had heavy shutters they put on the windows. You'd see the storm coming and we did on the shutters in the house too, on the weather side. Although there was a sort of breakwater outside of that. But the sea did come in through the cellar window and filled the water system with salt water. I guess that happened a couple of times. After I left, the greatest storm that did the most damage ever was in March. It washed that breakwater down and there was an old house made of brick down on the bank that held six tanks of kerosene for the light. The storm washed that down. And there was a big bank of batteries on the southern wall. When the storm washed that breakwater down it smashed the wall and smashed those batteries up and put everything out of commission. There wasn't any power for the radio beacon or light.
- I:** Were the batteries the only source of electricity?
- RF:** Yes. They were big glass batteries. I think they was the Edison type batteries — 110 volt DC and we had converters that converted the current to AC.
- I:** So you could have electric lights in your house?

- RF:** Oh, yes. We didn't while we were there, you see, during the war the families had to be moved ashore — to the mainland. And they never got the advantage to use the electric light. Eventually they did get around to wiring up the light and wiring up the houses.
- I:** Did you have your own vessel or did the Lighthouse Service supply you with one?
- RF:** The Lighthouse Service provided a station boat. It was more or less a twenty-foot light boat with a single cylinder engine in it.
- I:** Where would you normally get your provisions from?
- RF:** On Petit Manan we normally would get it from Milbridge. Once in a while we'd go to Jonesport but that wouldn't be very often. At Matinicus Rock they had a nice store at Matinicus Island and a Post Office.
- I:** Did you ever go to Rockland?
- RF:** Not for provisions.
- I:** What kind of a docking facility was on Matinicus Rock?
- RF:** Well, they had a slip, you see there was a boat house high up on the shore and a slip on down to low water — that was a double slip. You had two choices. You'd run for one strip and you might miss it and wind up on the other one or you might go in the rocks, too. But that didn't happen very often.
- I:** Then, how did you get the boat up the slip?
- RF:** We had a winch.
- I:** How long did your family live with you on the Rock?
- RF:** Well, you moved ashore about 1942 didn't you Dorothy? Somewhere's right around there.
- DF:** '36 to '42? Yes, I had two daughters. We had to board them ashore of course. Yes, I was there a while during the war.
- RF:** And they didn't get around to making them leave until the war was pretty nearly over. There was a crew of coast guard boys — nine or ten out there they had to stand tower watch. Watch for shipping, submarines, what have you and they'd keep transferring those boys out.
- I:** Did your daughters live on the Rock?
- RF:** Oh, yes, but we'd board them ashore during the school year. One of them graduated from Rockland High School and one of them graduated from Brownville High School — and she still lives in Brownville.
- I:** Did your family take any part in helping you with your duties?
- RF:** No. About the time, oh, Abbie Burgess' time there was keeper — those days were different, you see. They didn't have any folks. All they had was a light and those kind of lights were very hard to keep and especially in the winter

time. I did read in the story of her about the old whale oil lamps that they had originally. In the winter time when the oil flowed slow — they had some kind of means of keeping them warm. As a matter of fact, in severely cold weather we had to be in the tower pretty near all the time and keeping a torch — alcohol torch for a little extra heat. That didn't happen very often. It was mighty cold up in that old tower I'm telling you. It was dead cold.

- I:** No source of heat except the lamps?
- RF:** No.
- I:** Did you do any fishing while you were there?
- RF:** Oh yes. We were given the privilege of lobster fishing — fishing as part of our income.
- I:** Did you have to have a license to do that?
- RF:** Yes, but in those days it only cost a dollar.
- I:** Was there any limit to the number of traps?
- RF:** You could fish all you could fish as long as it didn't interfere with your station duties.
- I:** Did you have the privilege of selling the lobsters as you wished?
- RF:** Oh, yes. I guess I probably had eighty traps. We had to haul them by hand you see.
- I:** Did you use your own boat for that or did you use the light station boat?
- RF:** Oh, no, we had our own rowboat.
- I:** Did you put those traps mainly within an easy row?
- RF:** Oh, yes, right around the Rock.
- I:** Did your family help you in any way with that work?
- RF:** Well, Dorothy used to knit the bait bags. She didn't knit many heads. I did most of that.
- I:** Would you like to describe for us some of the storms you experienced while you were on Matinicus?
- RF:** Of course, it was out in the gusty ocean, so to speak. We were there in that 1938 hurricane although we didn't get it as bad down there as they did in Massachusetts. We got plenty of it, but the seas act funny. I don't know whether you have ever been out when it's been heavy sea running. I've seen them when they go over the island. What does the damage is when one of the waves what we call piggybacks, you know what I mean? One of them, there'd be a double you see, and sometimes a triple one. One wave will try to climb the other's back. That is the real power in the sea. You wouldn't realize it until you saw what it will do. And when you get one of those, that's what does the damage on those light stations and over those ledges. It's one of those what we call piggybacks. The sea can make up too quick too. I've gone up to Matinicus Island after the mail and it went alright. It was fairly calm. And when we come back to the Rock it was all we could do to land!

- I:** Did you have long periods of time when the weather was particularly bad?
- RF:** Yes, there was. There was two weeks at a time we never got the mail out. That would be in the winter, of course.
- I:** Was the winter usually the worst part of the year for the weather?
- RF:** Oh, yes, oh sure.
- I:** Was there a particular month you dreaded more than others?
- RF:** Anytime from November until April. March was pretty good although we'd get some pretty heavy storms in March, but February was generally the windy month for northeasters. And along the fifth, sixth, or seventh of February you'd generally get a bad one.
- I:** Was there ever a time when you had gone to get provisions or the mail that you couldn't get back, you had to wait for some time?
- RF:** No, we always managed to land. Somehow or other, end over end, somehow or other. We'd been pretty lucky. Those days they didn't take a man into the lighthouse unless he had quite a bit of sea experience. You know, been a fisherman or some other seafaring experience.
- I:** So, they were sure that you were able to handle whatever situation would come up.
- RF:** Well....

Reading the Book Abbie Burgess: Lighthouse Heroine

Abbie Burgess is a "fictionalized," but true, story of a fourteen-year-old girl. In 1853 she moved with her family from Rockland, Maine to the Matinicus Rock Light Station. She managed the light during great storms in 1856 and 1857. Abbie lived out her life on various light stations where her husband was keeper. This is a moving book which grade five to nine students rarely can put down once they start to read it.

The authors Dorothy Holder Jones and Ruth Sexton Sargent wrote the book especially for the early adolescent reader. Abbie Burgess was a heroine and her life serves as an excellent non-stereotyped sex role model.

The intent of this activity is to encourage students to read, to have students appreciate the life style of remote island living and to gain a better understanding of the role of the lighthouse and lighthouse keeper.



1861 View of Matinicus Rock Light

Chapter Questions for *Abbie Burgess: Lighthouse Heroine*

Chapter I

1. Why didn't Abbie have as much time to attend social events as she used to?
2. What are the reasons for building lighthouses?
3. How was the name Matinicus come by?

Chapter II

1. Who was Abbie's best friend?
2. Name the members of the Burgess family.
3. Describe Pratt's Store as you might picture it.

Chapter III

1. How long did the trip from Rockland to Matinicus Rock take?
2. Benjy seemed to have one major interest. What was it?
3. Describe the landing procedure at Matinicus Rock.

Chapter IV

1. How large is Matinicus Rock?
2. What was the Burgess' new home made of?
3. Why must a lighthouse keeper be a responsible person?

Chapter V

1. What did the Burgess' first breakfast on the Rock consist of?
2. What was the hairstyle of the girls on Matinicus Rock?
3. What was the *Provider*?

Chapter VI

1. List at least two sailor's poems which describe weather conditions.
2. What was Lydia's main interest?
3. What did a bushel basket hoisted up the flagpole mean?

Chapter VII

1. How did Mr. Burgess intend to earn extra money during the summer?
2. What did Benjy bring back from the mainland?
3. Why was the barometer so important?

Chapter VIII

1. What could the girls do on the Rock to amuse themselves in the spring?
2. How was Mahala's mischievousness finally controlled?
3. What did Abbie seem to miss most about Rockland?

Chapter IX

1. What happened to Prissy when she landed at Matinicus Rock?
2. Where was Benjy going and what was he going to do?
3. What did Prissy give to Benjy as he left?

Chapter X

1. Who was the visitor that came to Matinicus Rock?
2. What did the visitor think about the Matinicus Rock situation when he left?
3. What were the names of Abbie's hens?

Chapter XI

1. What were lighthouse logs kept for?
2. What were some things Abbie learned from the logs?
3. What did Abbie and Mr. Burgess decide about the wooden chamber?

Chapter XII

1. What was the first big surprise of the Christmas season?
2. Who was the Christmas guest at Matinicus Rock?
3. What had Mrs. Burgess been doing all the while she was alone in her room?

Chapter XIII

1. Why do you think Abbie was uncomfortable back in Rockland?
2. What did Abbie do while visiting Prissy?
3. Describe the launching of the *Young Mechanic*.

Chapter XIV

1. What was the winter of tempests?
2. What was a Marblehead Turkey?
3. On what was Mr. Burgess' decision to leave based?

Chapter XV

1. What important change occurred after Mr. Burgess left?
2. Where did Abbie take everyone to be safe?

Chapter XVI

1. Where did Benjy hear of his sister's bravery?

2. What changes were due for Matinicus Rock?
3. Why did Benjy build a third dory?

Chapter XVII

1. Why was it so dangerous for Mr. Burgess and Benjy to sail in the winter?
2. What did Mrs. Burgess decide while Mr. Burgess was gone for so long?
3. Why might Mrs. Burgess fear living in Rockland also?

Chapter XVIII

1. Why was a new lighthouse keeper appointed?
2. Where did the Burgesses move to?
3. Who were the new people at Matinicus Rock?

Chapter XIX

1. How did Isaac describe Abbie when he said she was a strange girl?
2. Why did Abbie decide to leave?
3. What changed Abbie's mind?

Ordering Information for *Abbie Burgess: Lighthouse Heroine* by Dorothy Holder Jones and Ruth Sexton Sargent:

Down East Press
Camden, Maine 04843

Note: this book was originally published in 1969 by Thomas Y. Crowell Co., Inc.

Writing Lighthouse Poetry

Brasswork or

The Lighthouse Keeper's Lament

Lubec's Fred Morong, who spent a good many years of his life in the Lighthouse Service, was known by Keepers all along the coast as their unofficial poet laureate. While Fred was working at the Little River Light Station in Cutler, he wrote this poem that has become a classic in the Lighthouse Service. We have edited the word "beat" in the third line of the poem and substituted the word "growl." You may want your class to write their own lighthouse poetry.

*O what is the bane of a lightkeeper's life
That causes him worry, struggle and strife,
That makes him use cuss words, and growl at
his wife?*

It's Brasswork.

*What makes him look ghastly consumptive
and thin,*

What robs him of health, of vigor and vim —
And causes despair and drives him to sin?

It's Brasswork.

The devil himself could never invent,
A material causing more world-wide lament
And in Uncle Sam's Service about ninety
per cent,

Is Brasswork.

The lamp in the tower, reflector and shade,
The tools and accessories pass in parade
As a matter of fact the whole outfit is made
Of Brasswork.

The oil containers I polish until
My poor back is broken, aching, and still
Each gallon and quart, each pint and each gill
Is Brasswork.

I lay down to slumber all weary and sore,
I walk in my sleep, I awake with a snore
And I'm shining the knob on my bedchamber
door.

That's Brasswork.

From pillar to post rags and polish I tote
I'm never without them for you will please note
That even the buttons I wear on my coat
Are Brasswork.

The machinery clockwork, and fog-signal bell,
The coal hods, the dustpans, the pump in the
well,

Now I'll leave it to you mates, if this isn't — well
Brasswork.

I dig, scrub and polish, and work with a might,
And just when I get it all shining and bright
In comes the fog like a thief in the night.

Good-bye Brasswork.

I start the next day and when noontime draws
near,

A boatload of summer visitors appear
For no other purpose than to smooth and
besmear

My Brasswork.

So it goes all the summer, and along in the fall,
Comes the district machinist to overhaul
And rub dirty and greasy paws over all

My Brasswork.

And again in the spring, if perchance it may be
An efficiency star is awarded to me,
I open the package and what do I see?

More Brasswork.

Oh, why should the spirit of mortal be proud
In the short span of life that he is allowed
If all the lining in every dark cloud

Is Brasswork?

And when I have polished until I am old
And I'm taken aloft to the Heavenly fold
Will my harp and my crown be made of pure
gold?

No, Brasswork!

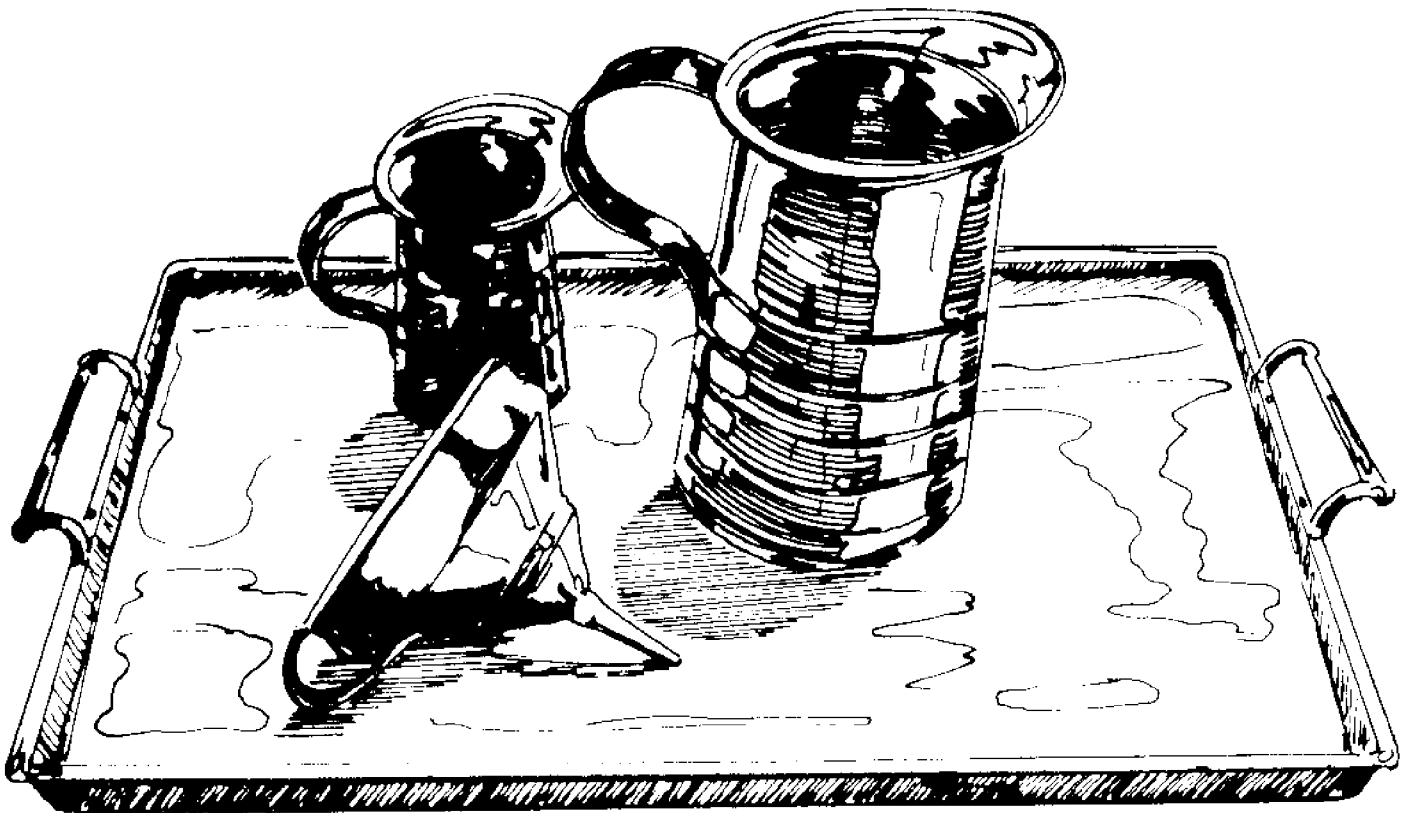

Lighthouse Brass

Log Writing Exercise

Part of the collection at Rockland's Shore Village Museum consists of handwritten lighthouse logbooks. Lighthouse watchstanders kept rough logs of noteworthy events. These events might include the hours the foghorn was in operation on a given day, special weather conditions that made it necessary to run the light during daylight hours, proper relief of the watch, and during the war, the sighting of vessels.

Your students could enjoy preparing a fictitious log page as it might be written by a lighthouse watchstander. It might also be written by a ship's captain approaching the coast from the sea sighting various lighthouses.

To increase the authenticity of this log page, you might want to have students use the 24 hour method of reporting time. It's easy to learn. All the times from midnight to noon are reported almost as we report them using a.m. and p.m. The only differences are that a zero is placed before any single digit hours and the suffix a.m. is deleted. For example, 8:43 a.m. is 0843, that is "oh-eight-forty-three" in words. 11:00 a.m. is 1100 or "eleven hundred."

In the 24 hour system, the numbering continues right on to midnight. Noontime is 1200, "twelve hundred." 1:00 p.m. is one hour later than noontime; so, it would be 1300, or "thirteen hundred" in words. Youngsters can easily learn to convert 24 hours system times to the a.m./p.m. system by remembering to simply subtract 1200 from any time which is greater than 1200. For example:

$$\begin{array}{r} 2315 \\ -1200 \\ \hline 1115 \end{array} \text{ so } 2315 \text{ is } 11:15 \text{ p.m.}$$

Sample Log Form:

Log Entry — Date _____
Hours fog horn operated _____
Daylight hours of running the light _____
Relief watches _____
Vessels sighted _____
Visitors _____
Special sightings _____
(i.e., fish, birds)

Lighthouse Projects

The information necessary to complete them is given in the books listed in the "Lighthouse Annotated Bibliography" section.

- A. Research and report on a specific lighthouse from the list provided in the "Teacher Resources" section. Students should provide

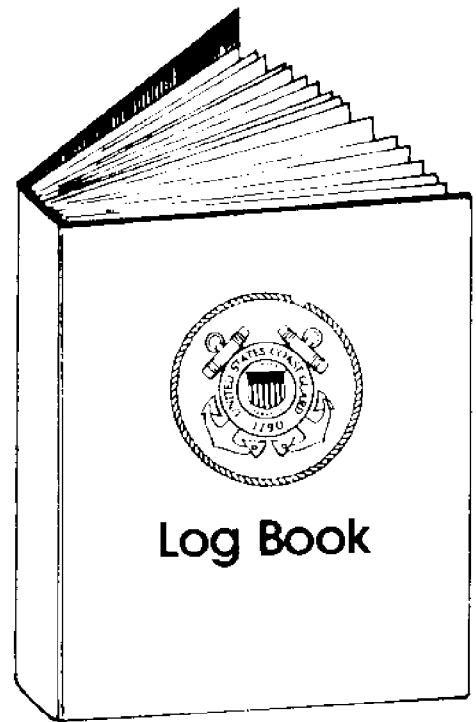

information on history, location, description of facilities, legends, past and present keepers, and any other interesting information.

- B. Make a scale model of a lighthouse, include any buildings and sheds, along with the main lighthouse. Buildings can be placed on a papier mache plaster of Paris rock. These buildings can be made of clay, oaktag, popsicle sticks, or any other suitable material.
- C. On a state highway map of Maine and New Hampshire locate all lighthouses listed in the "Teachers Resources" section. Pinpoint these lighthouses by putting a drop of glue on the appropriate spot on the map and stick a piece of colored toothpick in the drop of glue. Attach a small numbered flag to the toothpick. Next make a legend and include a short description of each lighthouse including its characteristics.
- D. Arrange a role-playing simulation of a government hearing on whether or not lighthouses should be automated.

Sketches are included in the pocket to offer details for writing and construction activities. In addition, you may wish to use the Down East Discoveries Film Strip of Maine Lighthouses.

These suggestions would make good small group projects.

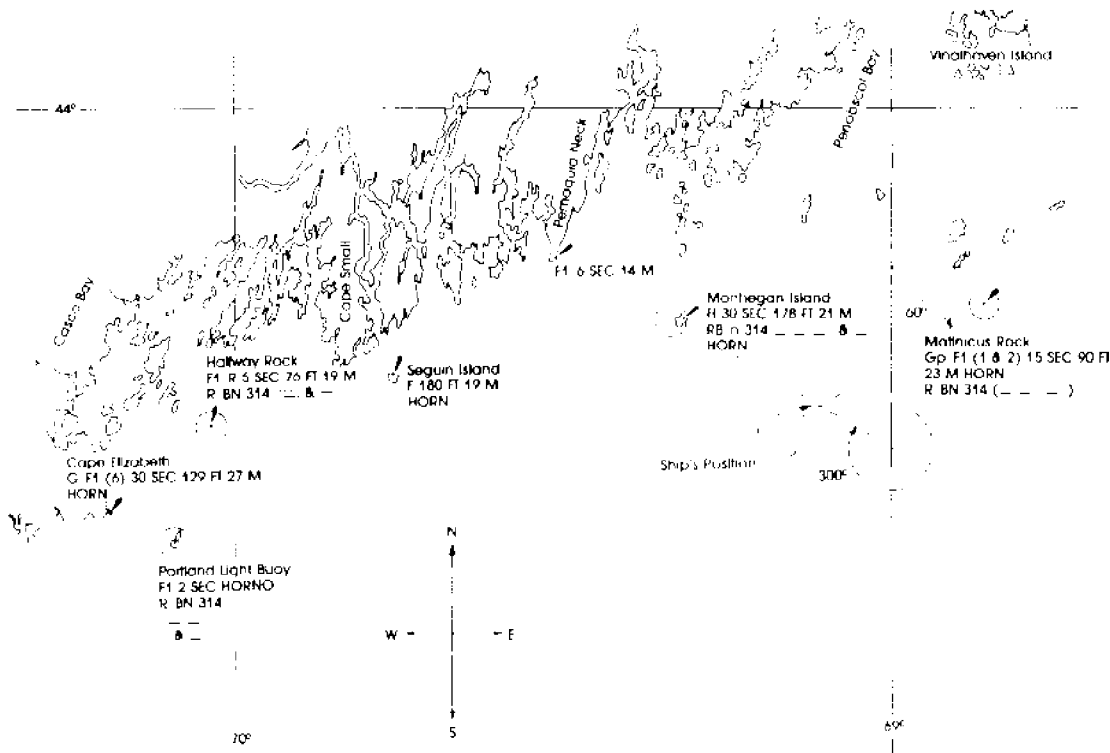

Solution to sample "Navigating from Lighthouses" problem

Navigating From Lighthouses

Use Chart section labeled "Cape Elizabeth to Matinicus Rock." Have your students assume that they are commanding a ship which is heading in toward Penobscot Bay from the south. They feel that they are somewhere south of Matinicus and Monhegan Island Lights.

At 2200 (10:00 p.m.) they sight a light which flashes in groups of one flash, a pause, and two flashes every 15 seconds which is Matinicus Rock Light. Using the ship's compass, they find the bearing to Matinicus Rock Light to be 060° true. These bearings are measured from true north, clockwise. The meridians run true north and south; so, a 060° true bearing to Matinicus Rock Light could be plotted by using a protractor to draw a line which formed a 60° angle with a meridian and which goes through the dot on the chart symbolizing Matinicus Rock Light. (See the example plotted for you.)

At the same time (2200), a light which flashes once every 30 seconds is spotted off the other side of the ship. This must be Monhegan Island Light. The true bearing to it is found to be 300°. That is, it bears 300° as measured clockwise from North as in the example. This bearing can be plotted by measuring 300° clockwise from North with a protractor and constructing a line which forms that angle with the meridian and intersects the Monhegan Island Light symbol. The same line

could be drawn by constructing a 60° angle counter-clockwise from North $360^\circ - 300^\circ = 60^\circ$.

The ship is at the intersection of these two bearing lines which are called lines of position. Determining the ship's position with this level of accuracy is called plotting a fix. A navigator would plot and label this fix as has been done in your example.

After students understand this procedure, give them some other bearings and have them plot different positions. They will see how knowing a ship's position this accurately could help keep it out of dangerous situations.

Bearings

These problems are based on the fictitious "Orono Bay" chart provided in the pocket.

1. If you were standing at the light on The Graves, what would the bearing of WHIS "3" be? Or RB "HR"? Of Peanut Island Light? Of Old Man Point Light?
2. What is the bearing of The Graves from Snake Point Light?
3. Draw a line of position (LOP) that would represent your position if Peanut Island Light had a bearing of 080° from your boat.

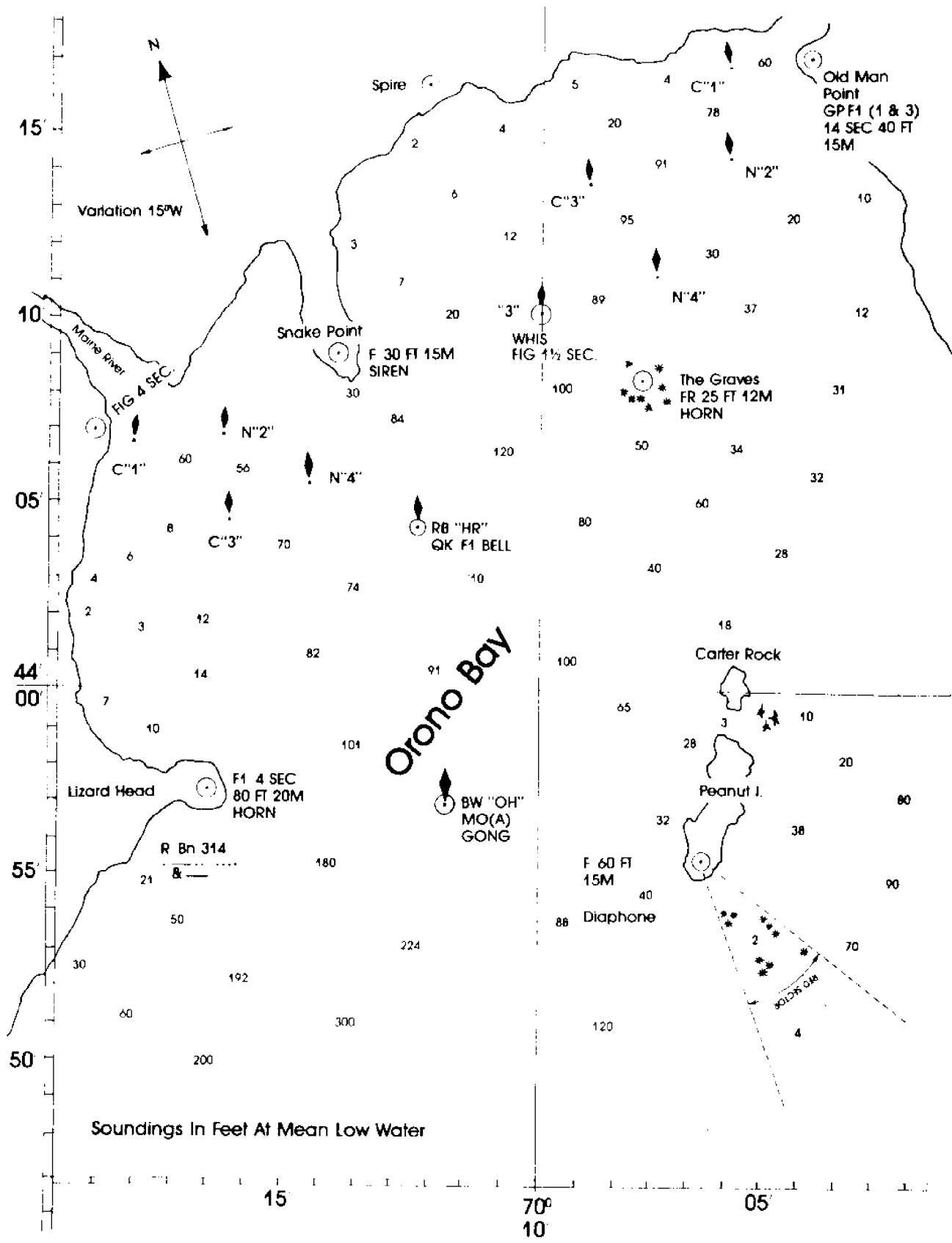

Use to plot solutions to "Bearings," "Dead Reckoning," and "Determining Latitude and Longitude" problems

4. What would your latitude and longitude be if you took bearings on The Graves and Snake Point and found The Graves to bear 355° and Snake Point Light to bear 310° ?
5. What would your position be if you took bearings on Lizard Head Light and found it to bear 130° and Peanut Island Light had a bearing of 060° at the same time?

Solutions to Bearing Problems

1. 305° ; 237° ; 173° ; 029°
2. 095°
3. Draw a line from Peanut Island Light toward 260° .
4. $144^\circ 01.8'N$, $107^\circ 07.5'W$
5. $143^\circ 51.8'N$, $107^\circ 11.7'W$

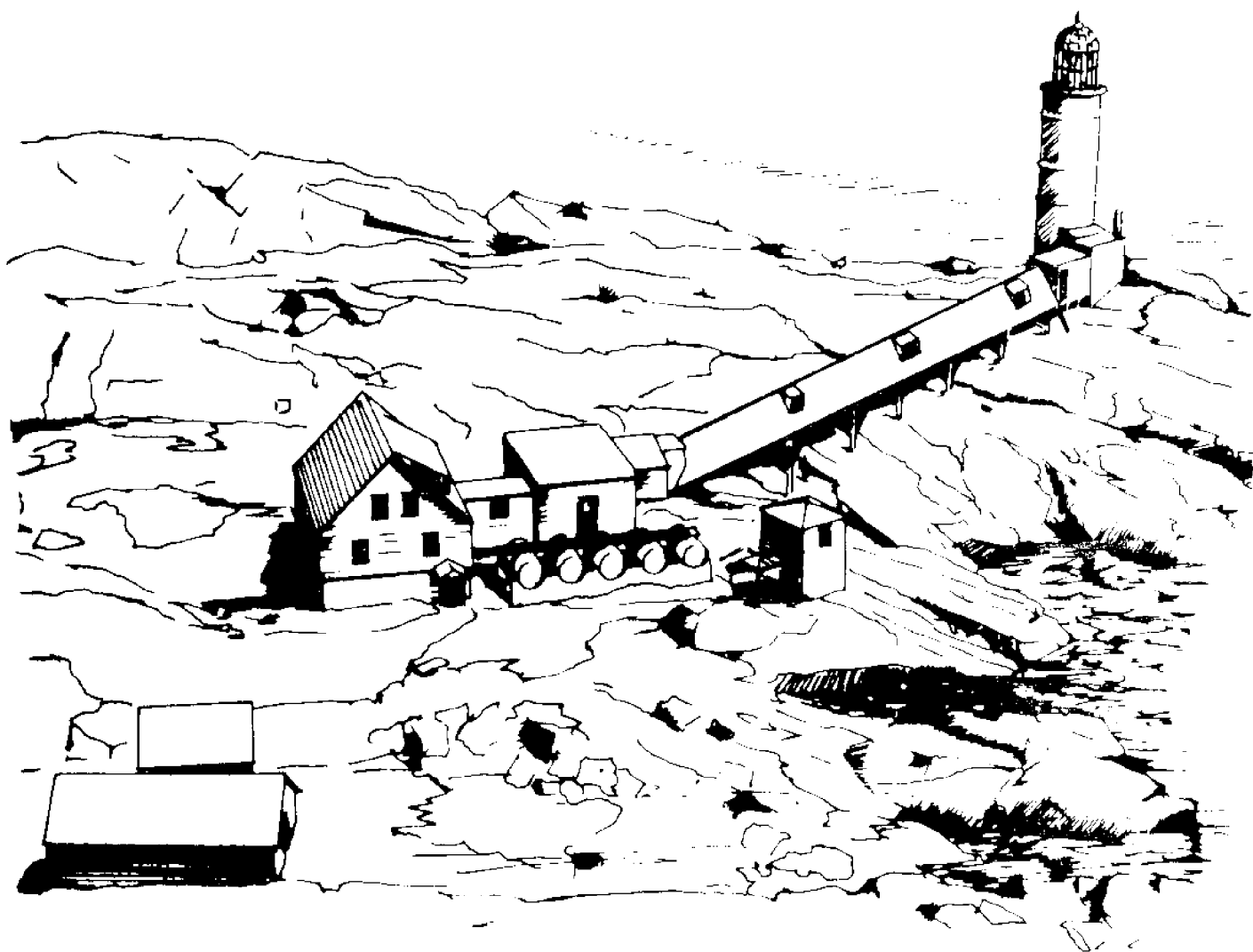

Isle of Shoals Light

Dead Reckoning Problems

Use the fictitious "Orono Bay" chart included in the pocket.

1. What is the distance in nautical miles from the black and white buoy "OH" to N"4" marking the channel by Old Man Point?
2. If you are at BW "OH" at 1300, what time will you arrive at N"4" marking the channel to Old Man Point if your boat is sailing at 5 knots. At 7.5 knots? At 6 knots? Would you steer this course directly, or would you make for a different mark first? Why?
3. What is the true course between BW "OH" and N"4" marking the channel to Old Man Point?
4. If you were close aboard whistle buoy "3", what true course would you order to enter the center of the mouth of the inlet by Old Man Point? About how far would you have to travel until you were in the mouth of the river?
5. Using the information in question 4, if you were close aboard whistle "3" at 2200, what time would you expect to arrive in the mouth of the inlet traveling at 9 knots? at 4.5 knots?
6. You've been sailing all night. Just before sunrise, you sight RB "HR" with virtually no visibility. What true course do you steer to reach the mouth of the Maine River? At 6 knots, what approximate time would you expect to be there? What two buoys would you pass close to?
7. In the above problem, about what time would you expect to be closest to the first of the buoys? To the second?
8. After picking your way in on a foggy night, you find yourself quite close to land and to a light-house, which you identify as Peanut Island Light. What true course do you steer to reach Whistle "3"?
9. In the problem above, you depart Peanut Island Light at 0100; what speed must you maintain to arrive at WHIS "3" at approximately 0230? At 0300?
10. Leaving WHIS "3" at 0600 for an offshore fishing trip, you steer true course 180°. You are steaming at 12 knots. What time do you expect to cross latitude 44°00'N?

buoys with a pair of dividers and compare it with the latitude scale on the left edge of the chart. The distance is 9' of latitude, or 9 nautical miles.)

2. 1448 at 5 knots $60 \times 9 = 5 \times T = 108$ minutes.
108 minutes = 1 hour 48 minutes.

$$\begin{array}{r} 1300 \\ + 148 \\ \hline 1448 \end{array}$$

1412 at 7.5 knots
1430 at 6 knots
The direct course from "OH" to N"4" leads very close to the rocks at The Graves. You would probably choose to steer for WHIS "3" first.

3. "OH" to N"4" is about 011° true.
4. About 042°; about 9.5 miles.
5. 2303 at 9 knots; 0007 at 4.5 knots.
6. True course 292°; 0605 at 6 knots. You'd pass close to N"4" and N"2".
7. 0515; 0541
8. About 345°
9. 10 knots to arrive at 0230. It's about 15 nautical miles to WHIS "3" from Peanut Island Light, and 0230 is 90 minutes from 0100.
$$60 \times 15 = S \times 90 \quad \frac{900}{90} = 10 \text{ knots}$$
7.5 knots to arrive at 0300.
10. 0650

A Cobscook Bay Plotting Problem

Use the chart section "Cobscook Bay" found in the pocket.

You are the skipper of a sailboat that sails in the Cobscook Bay. She will leave her anchorage at approximately L 44° 52.4'N, Lo 67° 09.3'W and will work her way east and north until she reaches the northern end of Seward's Island.

1. Locate the buoy on Birch Point Ledge just north of the northern end of Seward Neck. Describe the buoy by shape, color, and number.
2. Just south of Shackford Ledge (south and east of Birch Point Ledge) is buoy N"4". Plot the course from the buoy on Birch Point Ledge to N"4" on Shackford Ledge. Determine the true direction from N"8" to N"4".

Solutions to Dead Reckoning Problems

1. 9 miles (remember, 1 nautical mile = 1' of latitude; so, measure the distance between the

3. Assuming a boat speed of 4.6 knots, how long will it take you to traverse the course between these two buoys?
4. If you leave N"8" at 0832, what time will you expect to arrive at N"4"?

Outdoor Navigation

Dead Reckoning means "Deduced Reckoning" of a position on a chart. This technique has been used since before Columbus to try to ascertain position on a map without the benefit of visual guides. Mariners simply followed a course direction by magnetic compass, and noted the speed at which they were traveling. For instance, a navigator would change his course by the compass after traveling a certain period of time at a certain speed. This method is approximate because it does not allow for tidal changes, ocean currents, or wind direction.

Have students "navigate" a predetermined course, from one point in the school yard to another, looking straight down at the ground, using a watch and a simple magnetic compass to direct them. Have them move at a speed of approximately one pace (one meter) every second (or as desired). Make the course indirect, but not hazardous.

Example:

Course 045, for 17 paces,
at 1 pace/second.



Navigate
due North
8 paces at
1 pace/2 sec.

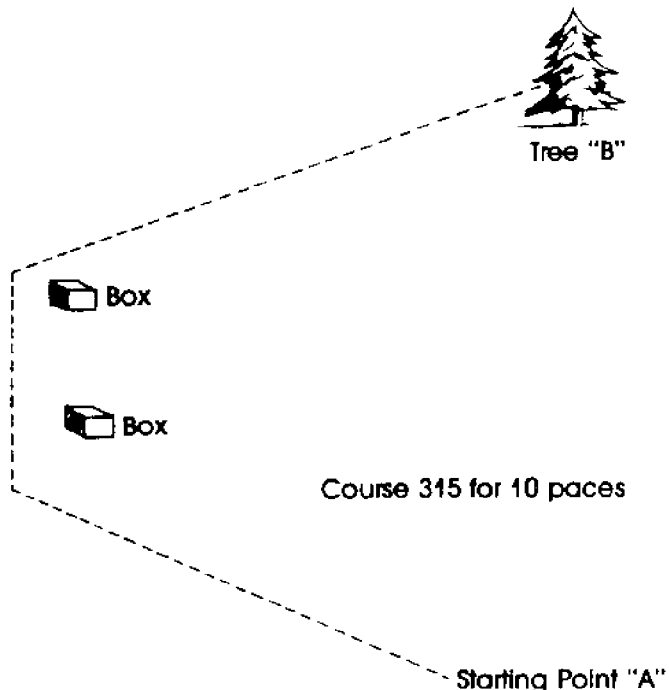

For variations in this exercise:

- a. You may wish to prevent outside tell-tale interference from biasing your students by using a paper bag or flight instructor's "hood" to limit peripheral vision.
 - b. Change the time-piece used from a watch to a 3-minute sand timer, such as used for cooking eggs. This is what people used before watches.
 - c. Remember the size of individuals will vary. Therefore, have tall and short students compare their pace lengths.
 - d. Try using more accurate measures, like a trundle wheel to guide the length of paces.
3. Unexpectedly delay the student or alter his or her direction slightly and have him compensate for the difference.

Relate these experiences to those of early sailors — in unknown oceans, in fogs, sailing for months without sight of land, spotting unusual sea animals, fearful of falling off the edge of the world...

After students have had experience with your course, have them form groups of four. Have each group design a course and then time groups through these student-made courses as an evaluation exercise.

Note: Be sure to use the method of expressing angles continuously from 000N back to 360N.

The Lighthouse Puzzle

Using Chart 13260, "Bay of Fundy to Cape Cod," or the midsection of that chart reproduced in the pocket as "Puzzle Chart," present this challenge.

Can you find places along the Maine coast where you could see six or more lighthouses from the same spot? (CLUE: Try drawing circles around the lighthouses using their ranges as printed on the charts as the radii. Where two or more of those circles overlap are places where you could see more than one lighthouse.)

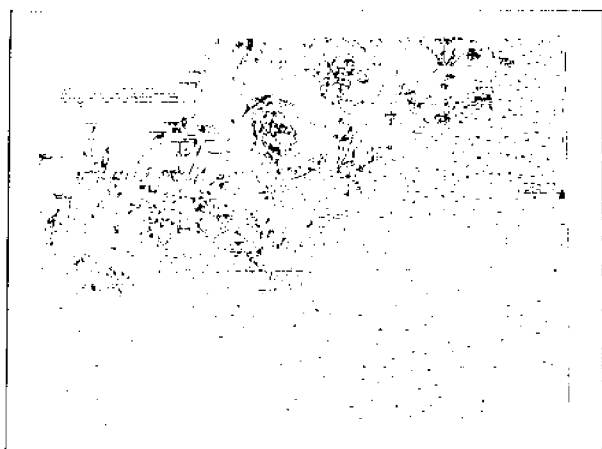

Puzzle Activity

Passage area on the chart. This is accomplished by the following:

1. Locate the 80 foot water depths within the passage. Look over the numbers printed in the "water" on the chart and find all those that are approximately 80 feet and shallower.
2. Roll the clay out into several long pieces.
3. Make a boundary around the passage, starting the edge of a piece of clay at the 80 foot depths. Also outline islands with clay. The boundary will delineate all areas from 80 feet deep up to dry land. A sample outline is provided in the pocket, which is called "Coast Outline for Head Harbor Passage."

Once the model is completed, the group should allocate the following roles among themselves: captain, navigational aids, and tidal currents. The object of the activity is for the captain to move the ship from the point of land marked "Head" through Head Harbor Passage to the point in the town (in the lower left corner near Friar Roads) marked "stack." The captain must accomplish this with his/her eyes closed (or blindfolded)! The role of the navigational aids person will be to guide the captain through this passage by giving verbal directions. He/she can only use the nautical terms of "port" (left), "starboard" (right), "full speed ahead," "full speed astern." The vessel cannot be stopped or turned around. The role of the tidal currents person is to slowly move the chart in the same direction as the ship's movement or in the opposite direction depending on whether that person decides the tide is ebbing or flowing. Try it once each way! Each group has only ten minutes to try and achieve this task, once on the ebb tide and once on the flow.

The Challenge of Head Harbor Passage

Materials Needed:

- Dittoed charts enough for 1/3 of your class. The chart section used for this activity is called "Head Harbor Passage" and is Chart 13328, "Calais to West Quoddy Head."
- Modelling clay — enough for 1/3 of your class members to each have one stick.
- Small wooden or plastic cubes — (use centimeter cubes) enough for 1/3 of your class.
- Blindfolds (optional)

Instructions:

Your class should be divided into groups of three. Each group of students receives one chart section, one stick of clay and one wood (or plastic) cube. The first task for each group to accomplish is to create a simple clay model of the Head Harbor

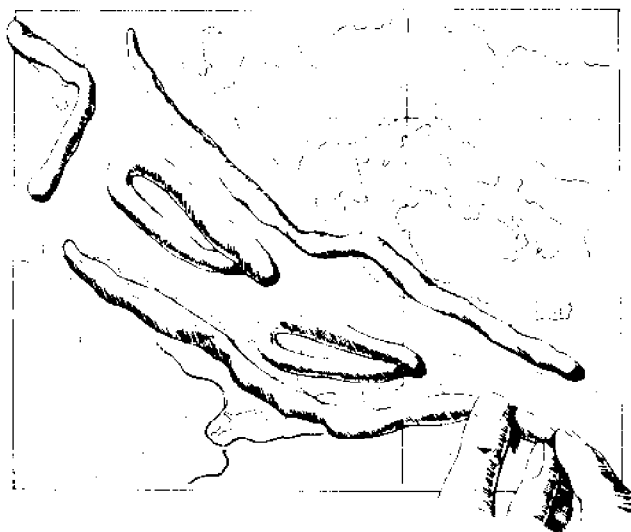

Challenge of Head Harbor Passage.

Quadrants

One of the tools which Columbus used to keep track of his position on the Atlantic was a quadrant. A quadrant measures approximate latitude by fixing an angle between the North Star (Polaris) and the center of the earth. A quadrant gets its name from 4 sets of 090 arcs in a single great circle about the earth. Since the center of gravity does not change positions and the position of the North Star does not vary appreciably, the angle as sighted is determined by the position of the ship. The greater the angle as measured off the North Star, the closer the vessel is to the North Pole. Degrees of latitude are measured in increasing increments from the equator north. The equator is 0 latitude, while the North Pole is 090 latitude. Each degree of latitude is subdivided into smaller units of 60 minutes (60'). In southern latitudes the degrees of latitude increase towards the South Pole.

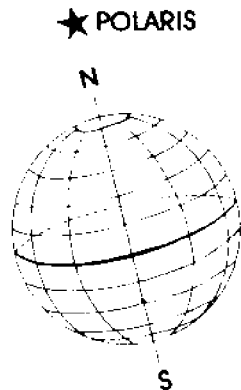

Instructions for measuring angles are illustrated to the right. Here are some approximate latitudes for some Maine and New Hampshire cities:

| NH | Position | Maine | Position |
|------------|----------|---------------|----------|
| Colebrook | 044° 54' | Fort Kent | 047° 15' |
| N. Conway | 044° 0' | Presque Isle | 046° 45' |
| Hanover | 043° 45' | Millinocket | 045° 35' |
| Laconia | 043° 30' | Dexter | 045° 0' |
| Concord | 043° 09' | Eastport | 044° 55' |
| Portsmouth | 043° 05' | Bangor | 044° 45' |
| Hampton | 042° 50' | Machias | 044° 40' |
| Manchester | 042° 50' | Waterville | 043° 30' |
| Nashua | 042° 45' | Augusta | 044° 13' |
| | | Lewiston | 044° 05' |
| | | Rockland | 044° 0' |
| | | Bath | 043° 50' |
| | | Portland | 043° 30' |
| | | Kittery Point | 043° 05' |

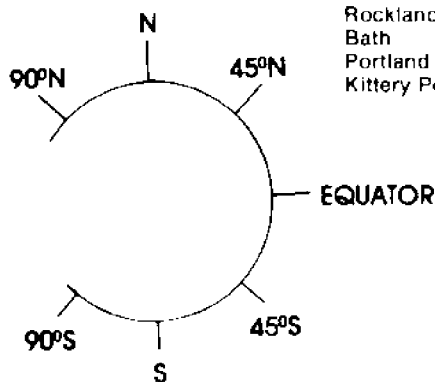

Polaris is the first star of the handle of the "Little Dipper" (Ursa Minor) constellation. To locate the North Star, first find the "Big Dipper" (Ursa Major) and use the two stars forming the side of the "pot" as guides toward the "Little Dipper" (as in the diagram). The "Little Dipper" is not always visible when the "Big Dipper" is, but Polaris should be.

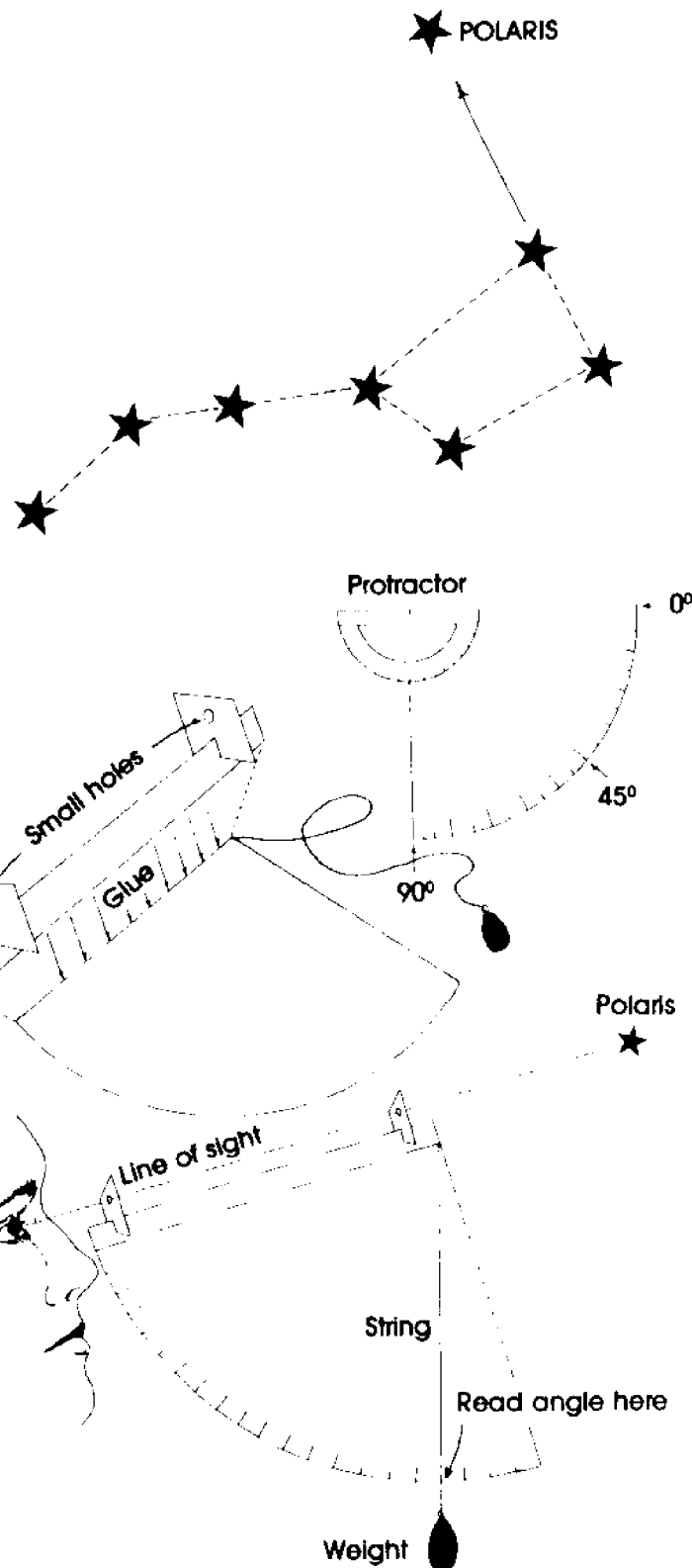

Determining Latitude and Longitude

These problems are based on the fictitious "Orono Bay" chart provided in the pocket.

1. What are the latitude and longitude of Snake Point Light?
2. What are the coordinates (latitude and longitude) of Peanut Island Light?
3. What are the coordinates of Lizard Head Light?
4. What are the coordinates of Old Man Point Light?
5. If you were at WHIS '3' and wanted to sail directly to $1\ 44^{\circ}00.0'N$, $10\ 70^{\circ}10.0'W$, what course would you have to steer? How far from the whistle is that point?
6. If you sailed 3 miles due west from buoy N "4" off Old Man Point, what would your position be at the end of those three miles (latitude and longitude)?
7. If you traveled 5 miles due north from BW "OH" and then turned to a due easterly course and traveled 3 miles, what would your position be?
8. What is the true course and distance from BW "OH" to $1\ 44^{\circ}05.0'N$, $10\ 70^{\circ}05.0'W$?
9. What is the true course and distance from $1\ 44^{\circ}05.0'N$, $10\ 70^{\circ}05.0'W$, to C "3" off the mouth of the Maine River? How long would you have to sail at 7 knots to cover that distance?
10. If you sailed the following courses at 6 knots for the time periods given, what would your location be at the end of these courses? Begin at WHIS "3"

TC 235 Time 1 hr. 10 min.
TC 145 Time 50 min.
TC 250 Time 47 min.

Solutions to Problems Determining Latitude and Longitude Based on the included chart.

1. $1\ 44^{\circ}\ 08.9'$ North; $10\ 70^{\circ}\ 14.2'$ West (can be rounded to nearest minute)
2. $1\ 43^{\circ}\ 55.4'N$; $10\ 70^{\circ}\ 06.8'W$
3. $1\ 43^{\circ}\ 57.4'N$; $10\ 70^{\circ}\ 16.9'W$
4. $1\ 44^{\circ}\ 16.7'N$; $10\ 70^{\circ}\ 04.4'W$
5. 180° ; 10 nautical miles
6. $1\ 44^{\circ}\ 10.9'N$; $10\ 70^{\circ}\ 10.0'W$
7. $1\ 44^{\circ}\ 01.8'N$; $10\ 70^{\circ}\ 09.5'W$
8. TC 048° ; 11.0 nautical miles
9. TC 268° ; 14.5 nautical miles; 124 minutes (2 hrs. 04 min.)
10. $1\ 43^{\circ}\ 58.5'N$; $10\ 70^{\circ}\ 14.7'W$

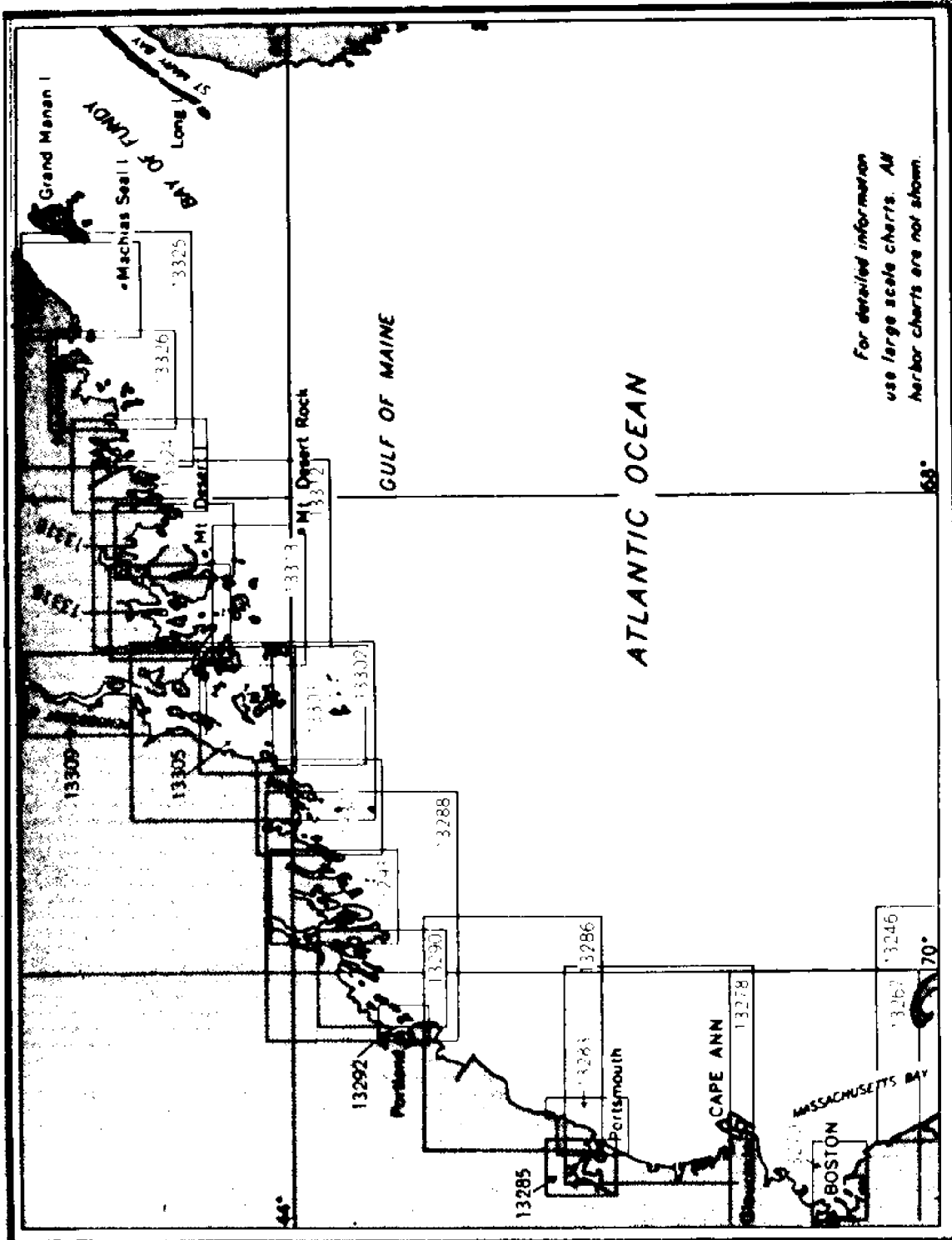

Chart Numbering System for the Gulf of Maine

Teacher Resources

Marine Charts

To obtain a highway map of Maine or New Hampshire, all you need to do is stop at your favorite local filling station. For mariners, marinas serve this function as outlets of marine charts. Other sources are listed in the "Teacher Resources" section.

A partial list of the charts generally covering Maine and New Hampshire follow. A chart diagram showing the range of coverage for each chart is provided on the facing page.

| Chart Number | Title | Scale |
|--------------|--|-----------|
| 13260 | Bay of Fundy to Cape Cod | 1:378,838 |
| 13278 | Portsmouth to Cape Ann | 1:80,000 |
| 13283 | Cape Neddick Harbor To Isles of Shoals | 1:20,000 |
| | Portsmouth Harbor | 1:10,000 |
| 13285 | Portsmouth to Dover and Exeter | 1:20,000 |
| 13286 | Cape Elizabeth to Portsmouth | 1:80,000 |
| | Cape Porpoise Harbor | 1:10,000 |
| | Wells Harbor | 1:20,000 |
| | Kennebunk River | 1:10,000 |
| | Perkins Cover | 1:10,000 |
| 13287 | Saco Bay and vicinity | 1:20,000 |
| 13288 | Monhegan Island to Cape Elizabeth | 1:80,000 |
| 13290 | Casco Bay | 1:40,000 |

| Chart Number | Title | Scale |
|--------------|---|----------|
| 13292 | Portland Harbor | 1:20,000 |
| 13293 | Damariscotta, Sheepscot & Kennebec Rivers | 1:40,000 |
| 13294 | South Bristol Harbor | 1:10,000 |
| | Christmas Cove | 1:10,000 |
| 13295 | Kennebec and Sheepscot R. Entrances | 1:15,000 |
| 13296 | Boothbay Harbor to Bath, including Kennebec River | 1:15,000 |
| 13298 | Bath to Augusta | 1:15,000 |
| 13301 | Muscongus Bay | 1:40,000 |
| | New Harbor | 1:10,000 |
| | Thomaston | 1:10,000 |
| 13302 | Penobscot Bay and Approaches | 1:80,000 |
| 13303 | Approaches to Penobscot Bay | 1:40,000 |

| | | |
|-------|---------------------------------------|----------|
| 13305 | Penobscot Bay | 1:40,000 |
| 13306 | Carvers Harbor and Approaches | 1:20,000 |
| 13307 | Camden, Rockport and Rockland Harbors | 1:20,000 |
| 13308 | Fox Islands Thorofare | 1:15,000 |
| 13309 | Penobscot River | 1:40,000 |
| 13310 | Belfast Harbor | 1:10,000 |
| 13312 | Frenchman & Blue Hill Bays & Apprs. | 1:80,000 |
| 13313 | Approaches to Blue Hill Bay | 1:40,000 |
| 13315 | Deer I. Thoro. and Casco Passage | 1:20,000 |
| 13316 | Blue Hill Bay | 1:40,000 |
| | Blue Hill Harbor | 1:20,000 |
| 13318 | Frenchman Bay and Mount Desert I. | 1:40,000 |
| 13321 | Southwestern Harbor and Approaches | 1:10,000 |
| 13322 | Winter Harbor | 1:10,000 |
| 13323 | Bay Harbor | 1:10,000 |
| 13324 | Tibbett Narrows to Schoodic Island | 1:40,000 |
| 13325 | Quoddy Narrows to Petit Manan I. | 1:80,000 |
| 13326 | Machias Bay to Tibbett Narrows | 1:40,000 |
| 13327 | West Quoddy Head to Cross Island | 1:40,000 |
| 13328 | Calais to West Quoddy Head | 1:40,000 |
| | Eastport Harbor | 1:5,000 |

For a definitive listing of all the United States Charts, consult *Nautical Chart Catalog* described with the publications of the U.S. Department of Commerce.

Publications of the U.S. Coast Guard

Light List Volume I (current year)

This publication contains a list of lights, fog signals, buoys, daybeacons, radiobeacons, etc. for sale from the U.S. Government Printing Office, Washington, D.C. 20402 and available from some chart distributors.

Navigational Rules: International—Inland

This publication contains rules for navigators and information about navigational aids.

Available from:

Coast Guard Marine Inspection Office
Office of the Commandant
G-CAS-3/TP26
U.S. Coast Guard Headquarters
2100 Second Street, SW
Washington, D.C. 20593

U.S. Department of Commerce — National Oceanic and Atmospheric Administration all ordered from:

Distribution Division
National Ocean Survey
Riverdale, Maryland 20840
Phone (301) 436-6990

Nautical Chart Catalog 1 (free)

Describes Nautical Charts, lists their costs and coverage. Also available from Chart Distributors listed below:

Maine

Auburn: Valley Sports, Inc., 10 Minot Avenue
Augusta: Kennebec Books, 82 Western Avenue
Loring Short & Harmon, 221 Water Street
Bailey Island: Dockside Marine, Mackerel Cove Road
Bar Harbor: Sherman's Book Store, 56 Main Street
Bass Harbor: Hanging Locker/Bass Harbor Marine
Bath: Shaws Bookstore, 49 Front Street
Belfast: Alternative Resources, 98 High Street
Hall Hardware Company, Inc., 52-54 Main Street
Blue Hill: Candage Hardware & Supply, Main Street
Boothbay Harbor: Pierce's Marine Service, Inc.
Brewer: Twin City Marine & Camping Hdqts., 99 S. Main Street
Brunswick: Macbeans of Brunswick, Inc., 134 Main Street
Calais: Johnson Company, 96 Main Street
Camden: The Owl and the Turtle, 8 Bay View
The Sandpiper, Harbor Square, Bay View Street
The Smiling Cow, 41 Main Street
The Village Shop, 25-27 Main Street
Wayfarer Marine Corp., Sea Street
Damariscotta: Damariscotta Appliance and Outboard Co., &
Chasse's Marine, 1 Faye Street
The Old Maine Shop, Maine Street
Eastport: S.L. Wadsworth & Son, Inc., 42 Water Street
Ellsworth: Shepard Hardware, West Main Street
Sterling Marine Supply, 162 U.S. Route #1
H.F. Wescott Hardware Co., 120 Main Street
Falmouth: Handy Boat Service, Inc., 215 Foreside Road
Five Islands: Sheepscot Bay Boat Co., Sheepscot River
Freeport: L.L. Bean Inc., Main Street
Kennebunkport: Chick's Marina, Ocean Avenue
The Sea Crafters, Ocean Avenue
Kittery: The Bosun's Locker, 48 Bowen Road
Jackson's U.S. Bypass #1 (Southbound)
Sea Cabin, Pepperell Road, Kittery Point Bridge
Manset: The Boathouse, Trispar Marine Co., Shore Road
Hanging Locker, Mansell Road
North Haven: J.O. Brown & Son, Inc.
Northeast Harbor: F.T. Brown, Main Street
Orland: M.D.I. Sailboats, U.S. Route 1
Pemaquid Point: Driftwood Crafts, Inc., Route 130
Port Clyde: Port Clyde Gen. Store, St. George Peninsula
*Portland: Chase Leavitt & Co., Ten Dana Street
The Open Book, 1141 Commercial Street
Robinhood: Robinhood Marine, Inc.

Rockland: Huston Tuttle Inc., 18 School Street
State News Company, 499 Main Street
The Shore Village Book Shoppe, 308 Magazine Street
South Bristol: Maritec
South Brooksville: C.A. Leach, Bucks Harbor, Eggmoggin
Beach
South Freeport: Harraseeket Marine Service, Main Street
Ring's Marine Service, Inc., on Harraseeket River
South Harpswell: Dolphin Marine Service, Inc., Basin Point
South Portland: Marineast at Mill Cove, 38 Ocean Street
Southwest Harbor: H.R. Beat & Sons, Inc., Clark Point Road
Southwest Harbor Boat Corp., Clark Point Road
Stonington: Atlantic Avenue Hardware, Inc., Atlantic Avenue
Tenants Harbor: Cod End, Wharf Street
Thomaston: Snow Harbor Corporation, Water Street
Waldoboro: S.H. Weston & Sons, Co., U.S. Route 1
Wells: Wells Harbor Marina, Lower Landing Road
West Southport: Brewer's Boatyard, Inc., Ebenecook Harbor
Winter Harbor: Winter Harbor Marine Trading Corp., Sargent
Street
York: York Harbor Marine Service, Inc., Route #103

New Hampshire:

Dover: Benn's Marina, 423 Dover Point Road
Hampton Beach: Hampton Beach Marina, Inc., 55 Harbor Road
Manchester: Yacht Sails, Inc., 1090 Second Street
Newington: Great Bay Marine, Inc., Fox Point Road
Northern Marine Enterprises, Inc., Spaulding Turnpike
Seabrook: Driscoll's Marine Inc., Route 1

Chart No. 1: Nautical Chart Symbols and Abbreviations

Lists much interpretive chart reading information,
25 pp.

United States Coastal Pilot, 1

Atlantic Coast: Eastport to Cape Cod (published
annually). Provides descriptions of coastal
approaches, coastlines and services - supplies
available to mariners. An excellent travel guide of
the coast even for armchair navigators.

Tide Tables: East Coast of North and South America (published annually)

Source of authentic tidal information.

Audio Visual Aids

Filmstrip: *Lighthouses of Maine* by John Danila,
Downeast Discoveries, Brunswick, Maine, 1976.
Purchase only, available in some local A-V centers.

Slide/tape Program Order From:

Lighthouse slides, script and tape. Service charge
of \$5.00 for each use, prepaid. Limited copies
schedule well in advance.

Dr. John W. Butzow
Northern New England Marine Education Program
College of Education
University of Maine at Orono
Orono, Maine 04469
(207) 581-7027 (telephone)

*Largest in our area

Annotated Bibliography

Lighthouses

Bachelder, Peter Dow. *Lighthouses of Casco Bay.* Portland, Maine: The Breakwater Press. 1975.

You have to admire an author who had to have thoroughly researched this topic to write a book that is so accurate and well-organized. The book has many helpful drawings and photographs. You surely will enjoy this superbly readable book.

Chase, Mary Ellen. *The Story of Lighthouses.* New York: W.W. Norton and Company, Inc. 1965.

A volume designed to cover the essential functions of lighthouses and the people who keep them, it succeeds superbly. The author writes with a very personal approach which should make this book extremely interesting for students. Also focuses on all aspects of lightkeeper's lives.

Coatsworth, Elizabeth. *Lighthouse Island.* New York: W.W. Norton and Company, Inc. 1968.

A book which reflects the love of the author for lighthouses, the people who keep them, and for the Maine coast in general. The story depicts a young boy's summer adventures on a small island off the coast of Maine inhabited by only a few people and a lighthouse. This book should be a pleasure for your students to read.

Duncan, Roger F. and John P. Ware. *A Cruising Guide to the New England Coast.* New York: Dodd, Mead and Company. 1972.

A first class guide to the ports along the coast of New England including the Hudson River, Long Island Sound, and the coast of New Brunswick. Presented in a detailed, well-organized format, it is virtually indispensable for the cruiser of this vast region.

Frost, Walter S. Jr. and Harold S. Simms. *The Lighthouses of Maine.* 1980.

This is a concise booklet listing all seventy-one lighthouses in Maine and how they can be reached. It is primarily a guide for photographers and artists and has many helpful hints for the photographer. The booklet also contains many nice photographs of Maine lighthouses.

Giambarba, Paul. *The Lighthouse at Dangerfield.* Boston: Little, Brown and Company. 1969.

A good book for you, the teacher, to read to your students in class. It describes the responsibilities and chores of the typical lighthouse keeper.

Libby, H. *Story of the Pemaquid Point Lighthouse.* Damariscotta, Maine. 1975.

This is an interesting and informative booklet which focuses on the lighthouse and keeper's house at Pemaquid Point, Maine. It briefly covers the history of lighthouses, their necessity during ancient times, lighthouses in the new world, and the emergence of the coast guard. Lists dates of interest concerning lighthouses in America. An excellent book for the novice.

Sauer, Julia L. *The Light at Tern Rock.* New York: The Viking Press. 1951.

A very engaging story of a boy and his aunt spending an unexpected Christmas at the Tern Rock Lighthouse. Truly a very emotional and spirited book. Highly recommended for students.

Snow, Edward Rowe. *Lighthouses of New England, 1716-1973.* New York: Dodd Mead. 1973.

This publication is an update to the 1944 edition *Famous Lighthouses of New England*. Covers the entire history of New England and lighthouses right up to the present. Very thorough in scope, well-illustrated, and highly recommended to students and teachers alike.

Sterling, Rober Thayer. *Lighthouses of the Maine Coast.* Brattleboro, Vermont: Stephen Daye Press. 1935.

This knowledgeable author writes through experience, for he was a lightkeeper himself. A very worthwhile comprehensive book that uses an historical approach. An essential for anyone interested in Maine maritime history, for this book is a fine document of Maine lighthouses.

Wood, Pamela, editor. *The Salt Book.* Garden City, New York: Anchor Press/Doubleday. 1977.

A very captivating book about people involved in such activities as lobstering, sea moss harvesting, and manning lighthouses discussing their lives in

Maine and how they have changed over the years. Selections of particularly exciting descriptions would be good for reading aloud in class. A book anyone can and should enjoy.

Articles on Lighthouses in *Downeast Magazine*

Seaside Respite. XXII:35 S'75
Building Ram Island Ledge Light il. XXII:89 N '75
A beacon for 150 Years. il. XXII:91 Ja '76
Two Maine Coast Lights to be Automated. XXII:149 JI '76
Goat Island Light at Cape Porpoise. il. XXIII:143 Ag '76
River Lighthouse at Calais Declared Surplus Property. XXIII:98 N '76
Portland Head Light. XXIII:28 Mr '77
Grante Guardian of Rockland Harbor. il. XXIII:58-61 Mr '77
Two Lighthouses on the St. Croix River. il. XXIII:91 Mr '77
Nubble Light off Cape Neddick. il. XXIII:107 Ap '77
Coast Guard Light Switch. XXIII:30-31 My '77
Portland Head Light Darkened. il. XXIII:133 Je '77
Seguin Island Light Station. il. XXIII:141 JI '77
Deserting the rock: Mount Desert Rock. il. XXIV:42-43+ Mr '78
Owls Head Overlooking Penobscot Bay. il. XXIV:93 Ap '78
Lighthouse Badly Damaged by Winter Gale. il. XXIV:102 My '78
Penobscot Bay Lighthouse Faces Automation. il. XXIV:139 JI '78
I Remember... Boyhood Days at Portland Head Light. il. XXV:132+ S '78
Whitehead Light Station. il. XXV:101 O '78
West Quoddy Head Light. XXV:32 Ap '79

Article in *Maine Times*

"The Lights — They Still Do The Job — Especially on the Kennebec." 8/28/70, pages 8-9

Lighthouse Articles in Various Journals

Lava Flow Spared the Lighthouse; Kumukahi Lighthouse. il. *Sunset* 163:60 S '79
Lighting the Way for 100 Years; Jupiter Inlet Lighthouse. il. *Southern Living* 14:32 O '79
Open House at Two Lighthouses... Show at Treasure Island; Sentinels of Northern California. Coast. Il. *Sunset* 160:56+ Mr. '78

Science in Lighthousekeeping: Execution Rocks Lighthouse. *Science Digest* 83:96 Mr '78
To the Top; A. Bluer, Keeper of the Bishop Rock Lighthouse. il. por. *People* 10:67 JI 3 '78
Lighthouses in San Francisco Bay. il. *Sunset* 157:23 O '76
Lonely Sentinel of the Reef; Sand Key Tower. R. Martagh. il. *Sea Frontier* 22:274 8 S '76
Someone Ought to do Something About That! Saving Point Fermin Lighthouse. A Siger. il. por *Retired Living* 16:34-5+ O '76
What is for Danger! O. Rutherford. il. *Oceans* 9:44-51 N '76
Open Again — the Point Reyes light. il. *Sunset* 159:32 O '77
Sentinel in the Sound: Execution Rocks Lighthouse. F. Khar. il. *Sea Frontier* 23:361-4 N '77
Lighthouses. B. Schill. il. *Motor Boat and Sail* 137:74-6 Ja '76
National Forest Lighthouses. J.H. Cravens. il. *American Forest* 81:20-3 My '75
Tragedy at Scotch Cap: Lighthouse Destroyed by Tsunami. M.J. Mooney il. *Sea Frontier* 21:84-90 Mr '75
Lure of Light and Lens; Photography of Lighthouse by D. Witney. M.R. Weiss il. *Saturday Review* 2:43-5 S 20 '75
L'homme de genie: Use of Fresnel's Lens. L. Linquist. il. *Oceans* 7:58 63 N '74
Beacon, Marks and Signs. E.L. Schoen. il. *Sea Frontier* 19:154 63 My '73
Vanishing Wickies; Reprint from May 1972 Issue of Audubon. S. Rozin. il. *Motor Boat and Sail* 131:68-9+ Mr '73
Skerryvore Lighthouse. R.W. Munro. biblio. f. il. *History Today* 30:56+ S '80
Battered Beacon Still Stands (Cape Lookout Lighthouse) il. *South Living* 15:69 Ap '80
Last-Ditch Fight over Tallest U.S. Lighthouse (Cape Hatteras Lighthouse) W.L. Mac Dougall il. map *U.S. News and World Report* 89:87 N 10 '80

Navigation

Bowditch, Nathaniel. *American Practical Navigator*. Washington: Defense Mapping Agency Hydrographic Center. 1977.

This work is written in two volumes and is an extensive compendium of essential material for the mariner. Contains many helpful charts and illustrations. It is quite detailed in scope, but could be used by the novice as well as the expert.

Chapman, Charles F. *Piloting, Seamanship and Small Boat Handling*. New York: Hearst Magazines, Inc. 1941.

This publication is precise, thorough, and informative. Presented with numerous detailed maps, charts, and illustrations. Covers all aspects of navigation. Should be used as a reference tool.

Gardner, A.C. *A Short Course in Navigation*. New York: Funk and Wagnalls. 1968

This work covers the basic theory and practice of navigation for the amateur sailor. Charts, instruments, and tables are presented and carefully explained along with exercises for the beginner. The author, who for twenty years has been a professional navigator and spent ten years teaching the subject writes in a good style for the general reader.

Kals, William S. *Practical Navigation*. Garden City, N.Y.: Doubleday and Company, Inc. 1972.

This publication strips the mysteries from all methods of navigation — pilotage, electronic, and celestial — and works out step-by-step the various navigational problems that arise on inland waters, along shore, and offshore. Numerous illustrations enhance the ability of this book to be of tremendous benefit to the beginning navigator.

Maloney, Elbert S. *Dutton's Navigation and Piloting*. Annapolis: Naval Institute Press. 1978.

A first rate volume that stands second to none for accuracy, organization and helpful information. Very detailed, factual, and up-to-date information. Gives good explanations of equipment and its uses. Recommended for the teacher as a good reference source.

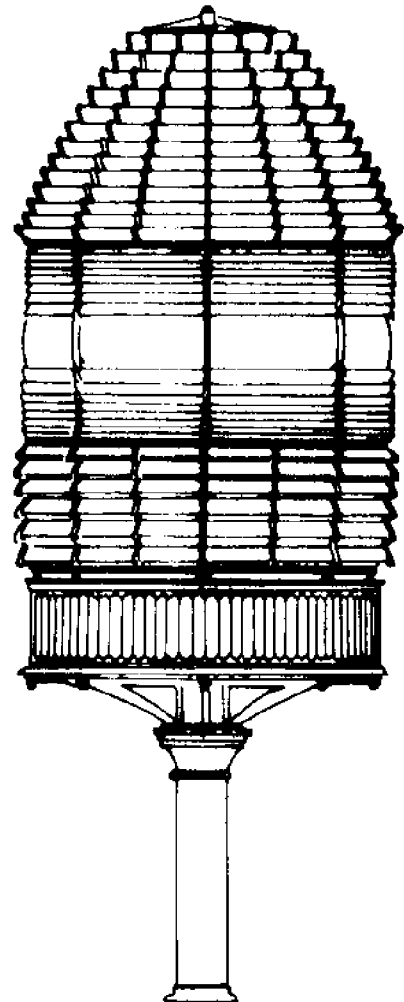

Fresnel Lens from Pettit Manan

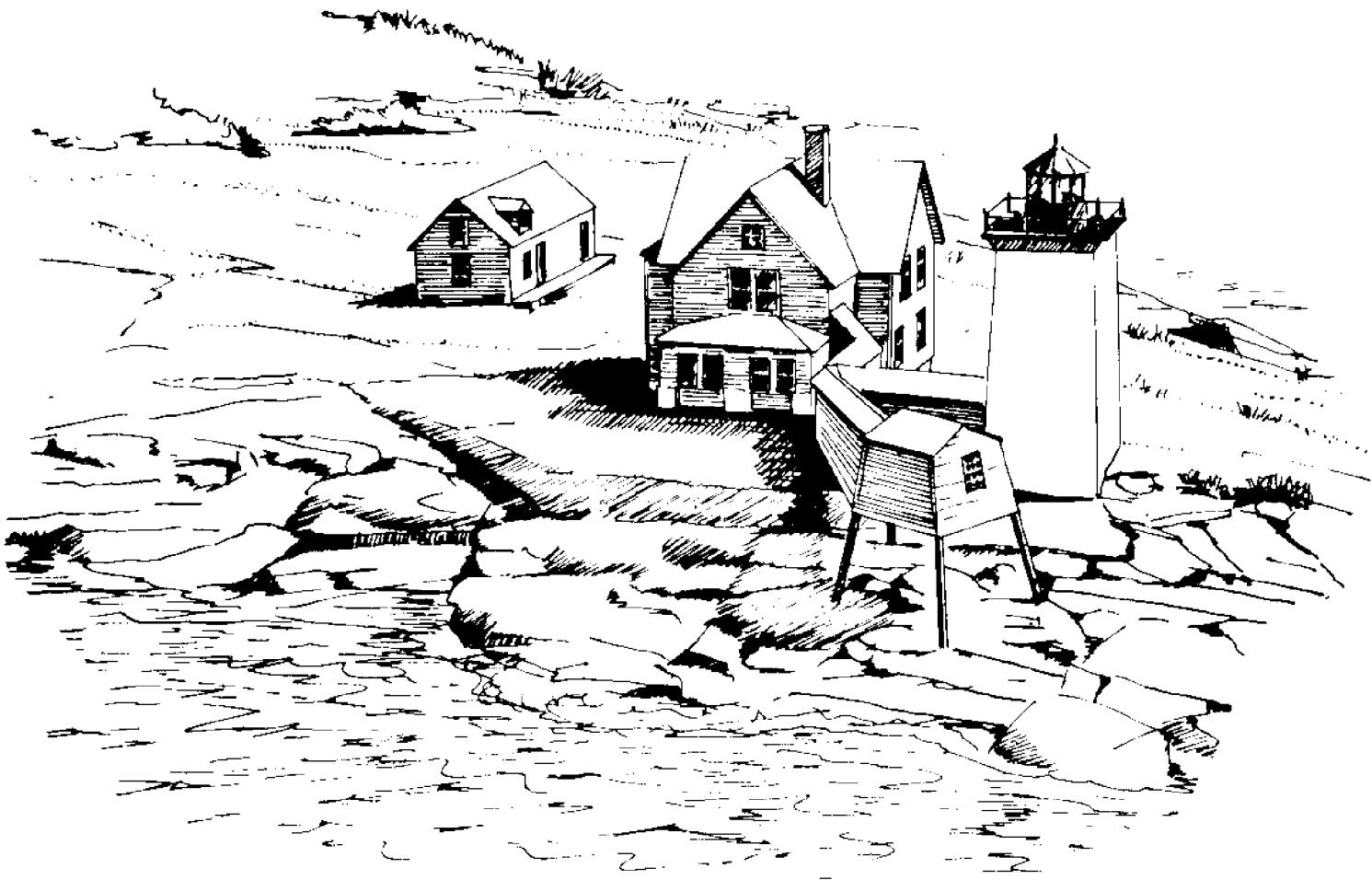

Hendricks Head Light

Places to Visit

Mainland Lighthouses

While there are many lighthouses in our region, listed below are a few of those which are fairly easily reached by car or bus as a personal or class trip.

| Light | Location |
|--|---|
| 1. Head Harbor Light (East Quoddy Head) | On East Quoddy Head at the North tip of Campobello Island, New Brunswick about ten miles from Lubec, Maine. |
| 2. Quoddy Head Light (West Quoddy Head) | In Quoddy Head State Park, about five miles southeast of Lubec, Maine. |
| 3. Bass Harbor Light | On the south side of Mount Desert Island between Sewall Campground and Bass Harbor. |
| 4. Fort Point Light | Adjacent to Fort Point State Park near Stockton Springs. |
| 5. Rockland Breakwater Light | At the end of a partially walkable breakwater (caution at high winds) in the center of Rockland Harbor. |
| 6. Owls Head Light | In Owls Head, across from Rockland Harbor. |
| 7. Pemaquid Point Light | Pemaquid Point at town recreation area at end of Pemaquid Point. |
| 8. Portland Head Light | At Old Fort Williams in Cape Elizabeth |
| 9. Cape Elizabeth Light (Two Lights) | At Two Lights State Park, Cape Elizabeth. |
| 10. Cape Neddick Light (Nubble Light) | Near York, Maine on the north part Nubble. |
| 11. New Castle Light (Portsmouth Harbor Light) | On Fort Point in Newcastle, near Portsmouth, N.H., part of Fort Constitution. |

Island Lights,

visited via mail boat or special ferry:

| Port of Departure | Vessel | Light | Location |
|-------------------------------|----------------------------|-----------------|--------------------------------|
| 12. Rockland, Maine | Marine State Ferry Service | Matinicus Rock | Matinicus Rock |
| 13. Port Clyde, Maine | Mail Boat | Monhegan Island | Monhegan Island |
| 14. Portsmouth, New Hampshire | Viking Queen | Isles of Shoals | White Island (Isles of Shoals) |

Transportation to Island Lights:

Matinicus Rock

The Maine State Ferry Service in Rockland, Maine provides irregular service to nearby Matinicus Island. Phone (207) 594-5543

Monhegan Island

Monhegan-Thomaston Boat Line

Port Clyde, Maine

Daily, except Sunday service in winter. Twice daily service in summer.

Phone (207) 372-8219

Isles of Shoals

Viking Queen

Viking of Yarmouth

P.O. Box 311

Portsmouth, New Hampshire 03801

Phone (603) 431-5500

Lighthouse Museums

Small museums can be found at Portland Head Light, South Portland, Maine, operated by the keeper, and at Pemaquid Point Light operated by the local town.

A major lighthouse museum in our area is located in Rockland, Maine:

The Shore Village Museum

104 Limerock Street

Rockland, Maine 04841

Phone (207) 549-4950, Priscilla Adams

A trip to Rockland to the Shore Village Museum and also the Coast Guard Station is highly recommended for those with an interest in lighthouses. Through the efforts of CWO (ret.) Kenneth Black, the Shore Village Museum has amassed a tremendous quantity of lighthouse equipment and other nautical artifacts. Many of the items mentioned in the Roscoe Fletcher interview and some equipment from Matinicus Rock can be seen in the Museum. All of the materials in the Museum are attractively displayed and some of the displays can be operated by your students. The Museum is separate from the Coast Guard Station and is locally owned.

There is no admission charged at the Shore Village Museum, but donations are welcome. The Museum is regularly open during the winter months, but appointments for special visits can generally be arranged.

| No. | LIGHT |
|-----|---|
| 1. | Head Harbor Light (East Quoddy Head) |
| 2. | Quoddy Head Light (West Quoddy Head) |
| 3. | Bass Harbor Light |
| 4. | Fort Point Light |
| 5. | Rockland Breakwater Light |
| 6. | Owls Head Light |
| 7. | Pemaquid Point Light |
| 8. | Portland Head Light |
| 9. | Cape Elizabeth Light (Two Lights) |
| 10. | Cape Neddick Light (Nubble Light) |
| 11. | New Castle Light (Portsmouth Harbor Light) |
| 12. | Matinicus Rock Light |
| 13. | Monhegan Island Light |
| 14. | Isles of Shoals Light |

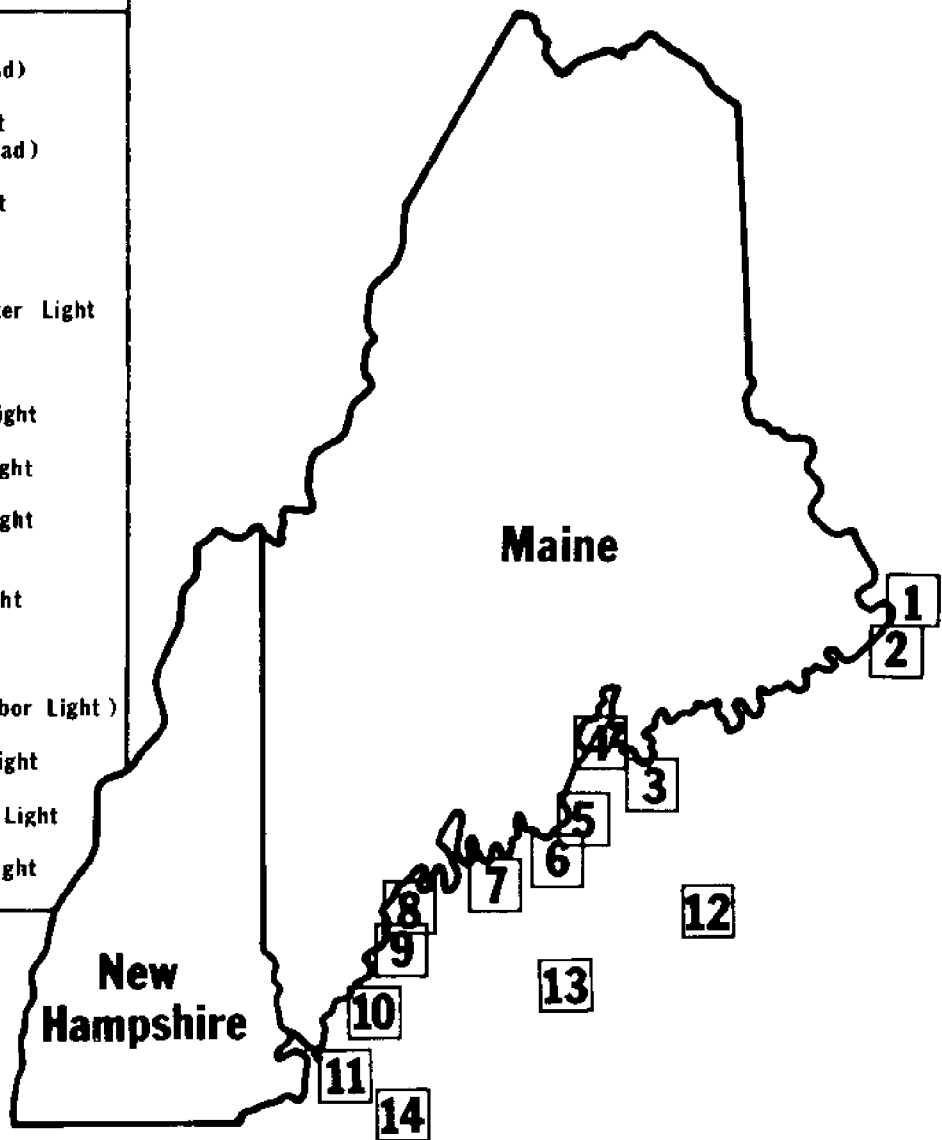

Easily Visited LIGHTHOUSES of Maine and New Hampshire



Perkins Island Light

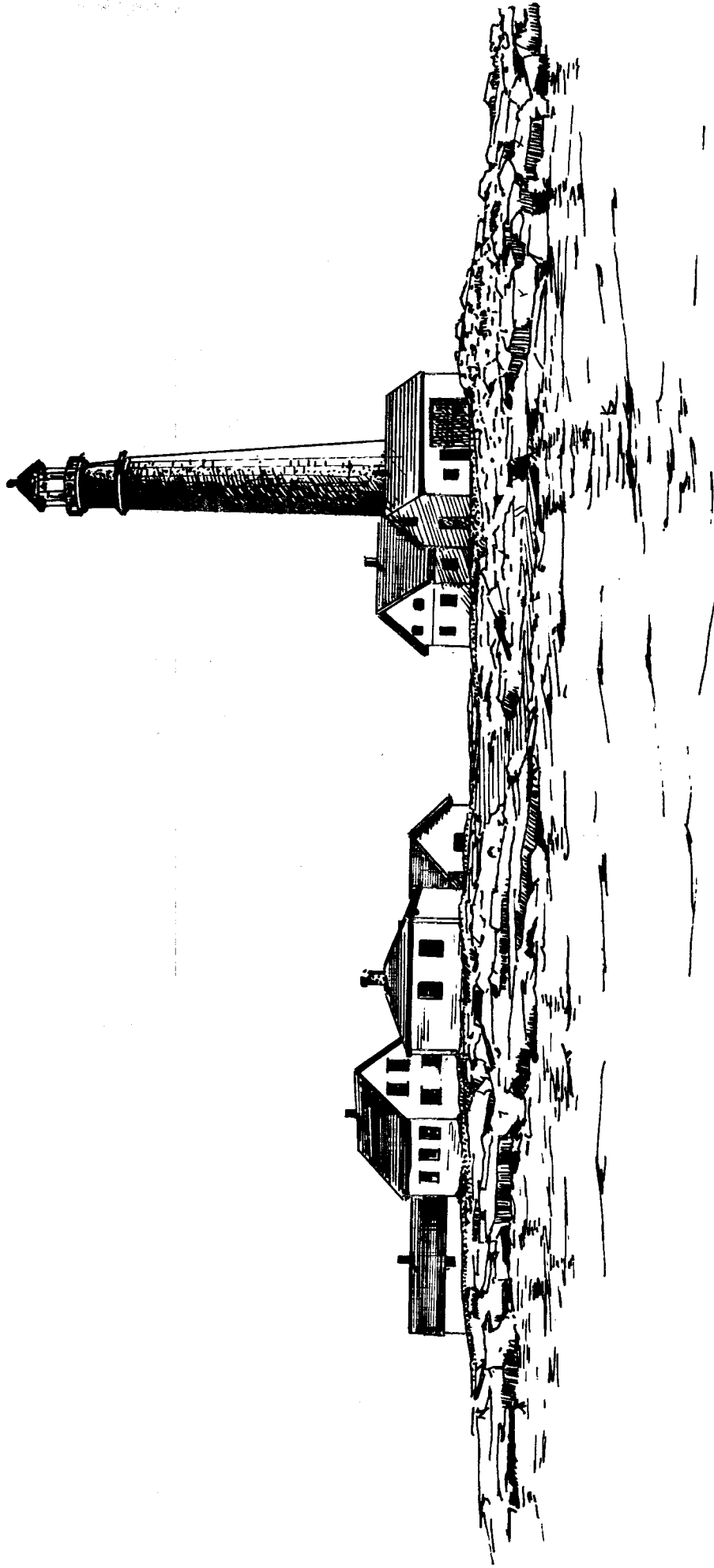

Petit Manan

Petit Manan is an ocean light 123 feet above sea level visible for 26 miles. Roscoe and Dorothy Fletcher went to Petit Manan in 1931. Roscoe Fletcher was an assistant lighthouse keeper on the light.

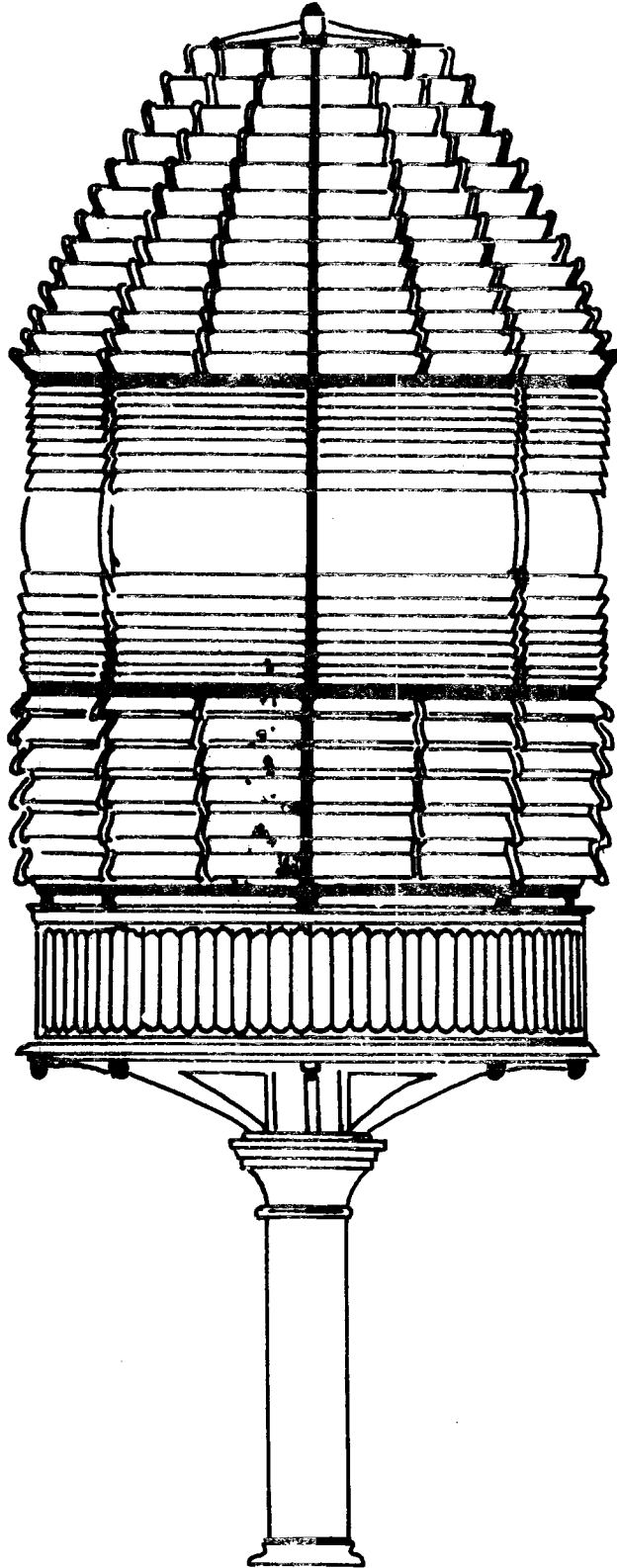

Fresnel Lens

This is a second order Fresnel lens from the lighthouse on Petit Manan. The lens itself is ten feet tall.

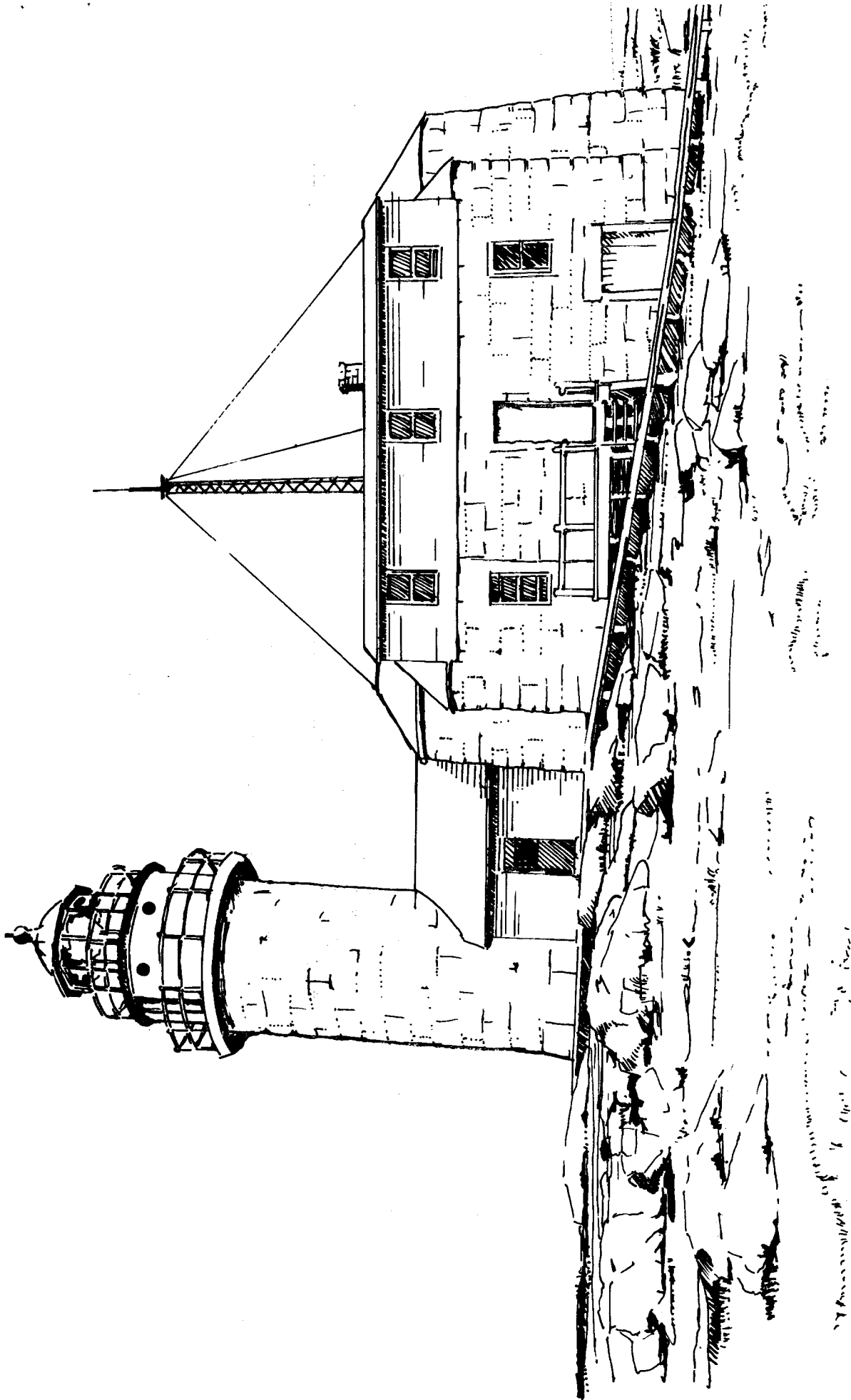

Matinicus Rock with Lighthouse and Beacon

Matinicus Rock is a small, barren rock located 22 miles southwest of Rockland. The Fetchers lived here from 1936 to 1945. Abbie Burgess lived on this Rock for 22 years. In Abbie's time, there were two ighthouses on Matinicus Rock. The antenna is for transmitting radio beacon signals to aid navigators.

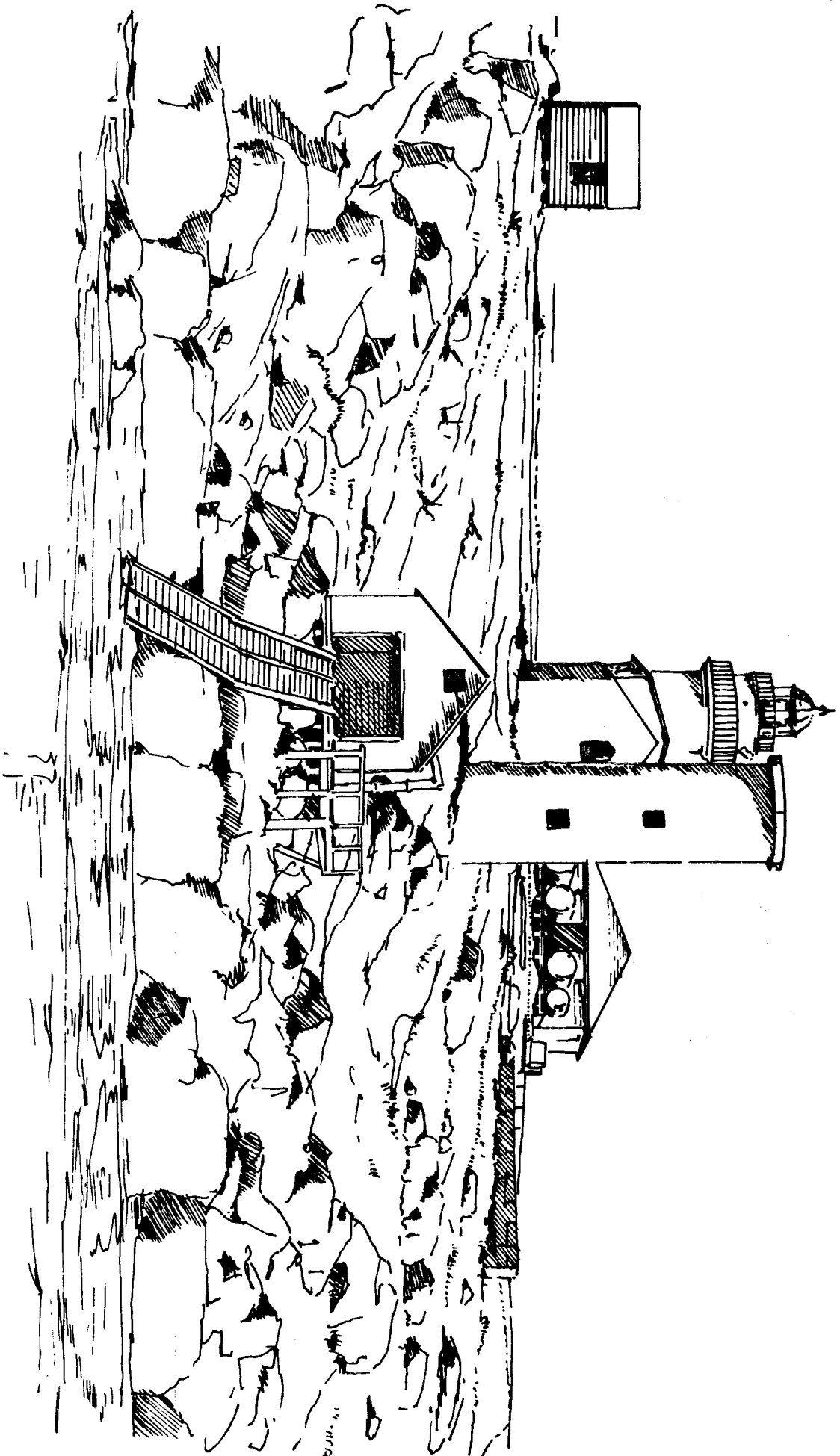

Matinicus Rock Boathouse and Ways

The boathouse and ways are located on the most sheltered spot on the Rock, but even that isn't very sheltered. Landing can only be accomplished on calm days. Landing on the Rock requires skillful boat handling, even on calm days. The "North Tower" is still standing, but it hasn't been used as a lighthouse since 1911.

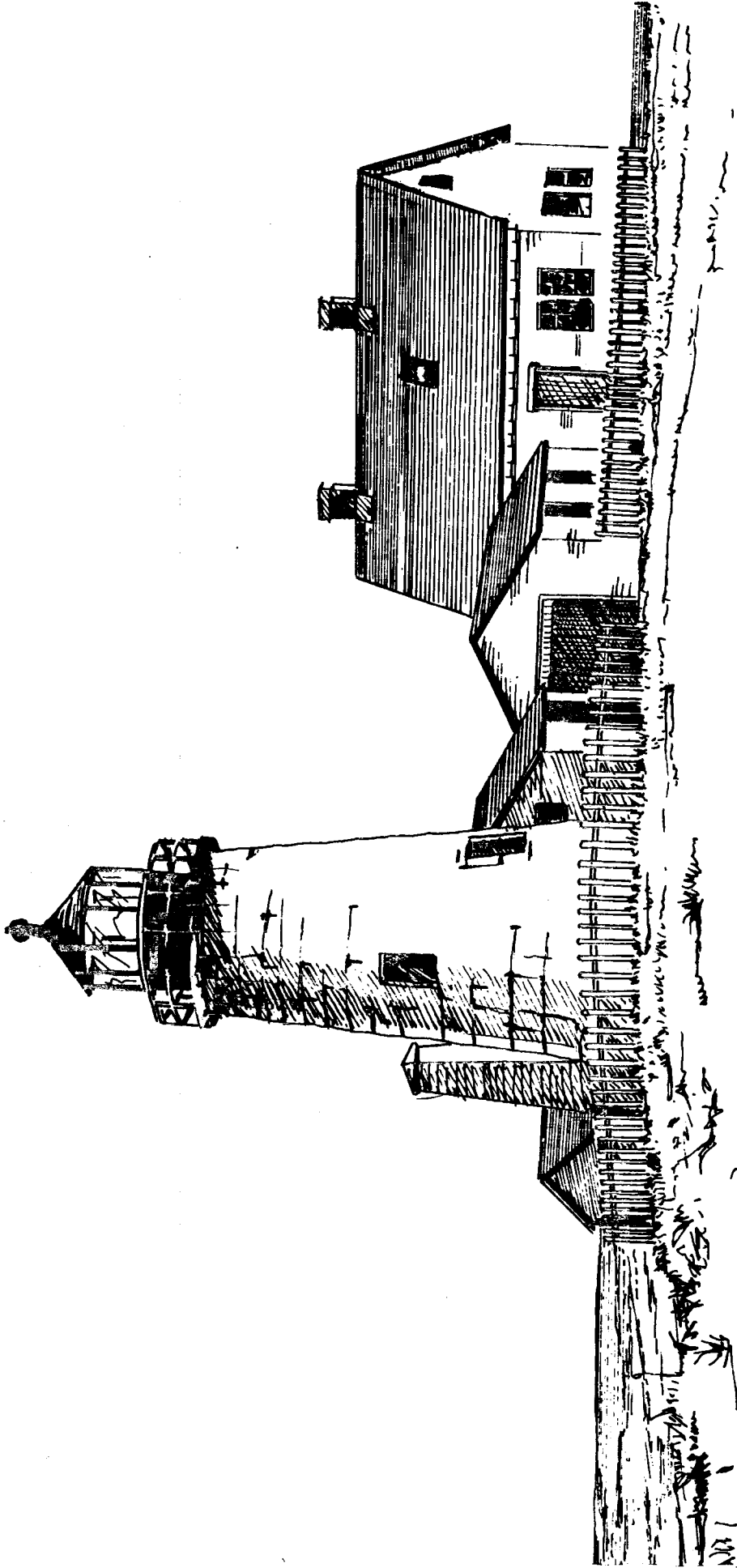

Pemaquid Point

If we travel a bit south and west of Matinicus Rock, we will find the famous Pemaquid Point Light.

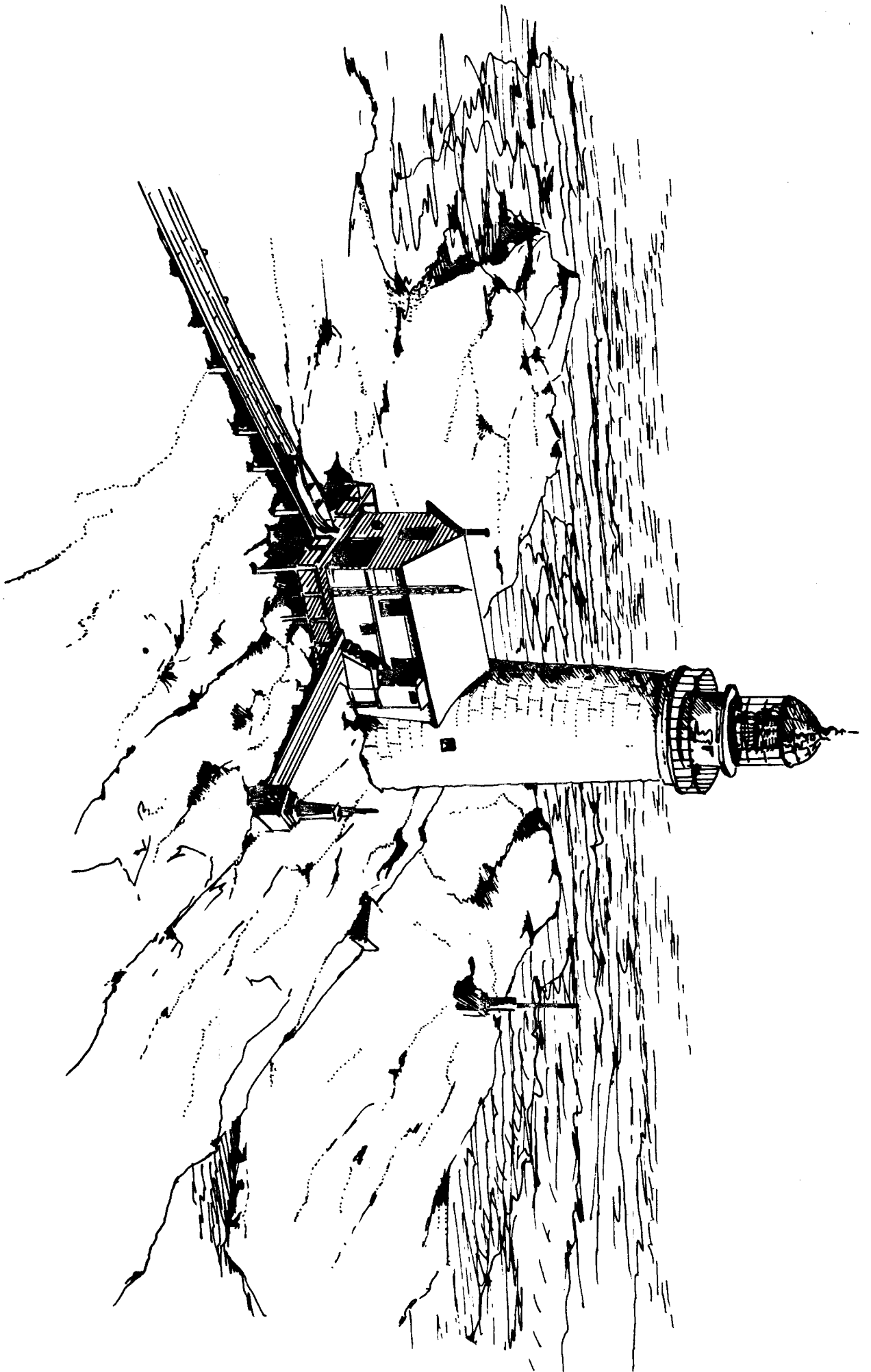

Halfway Rock Light in Casco Bay.

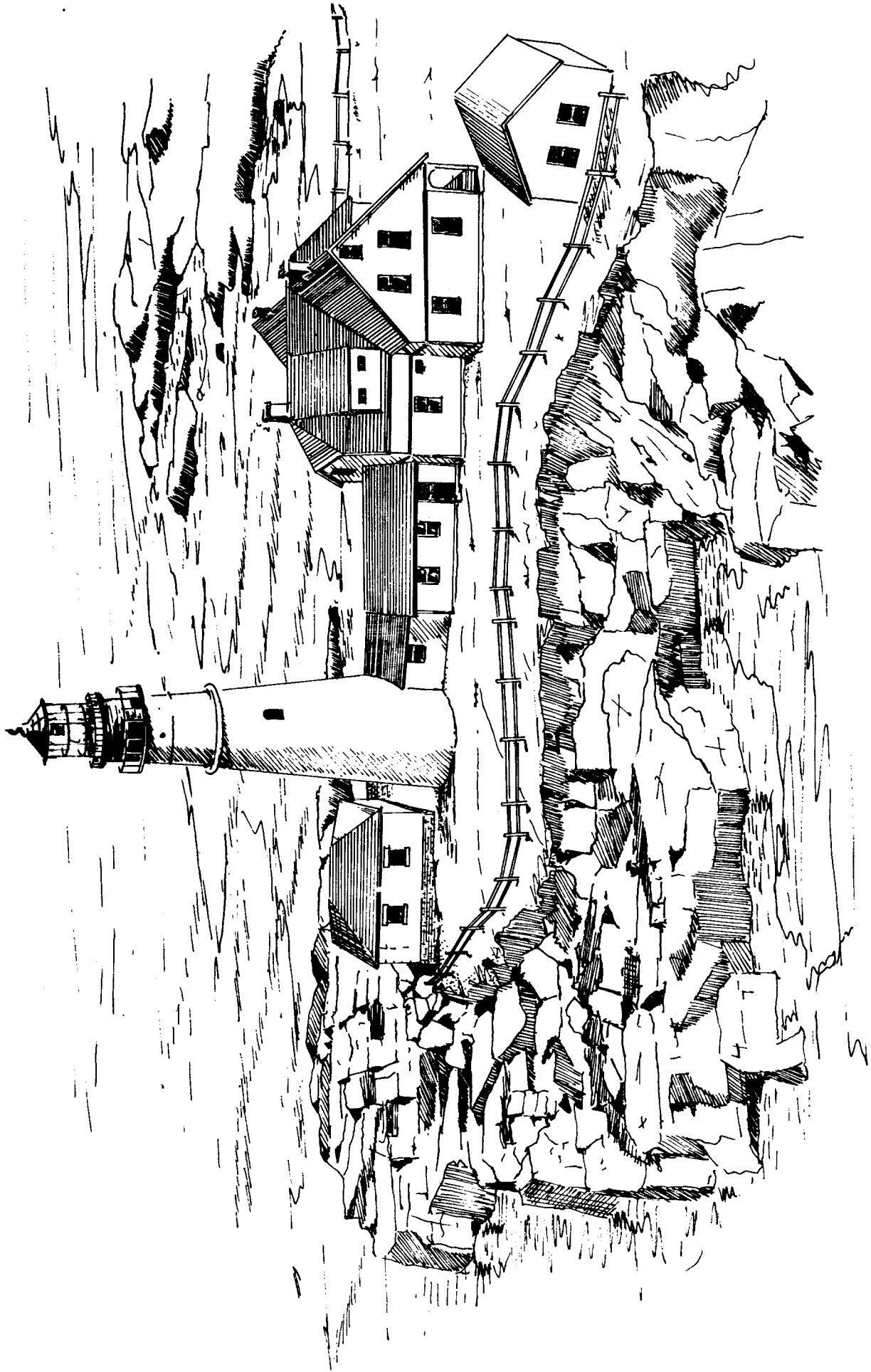

Portland Head

Portland Head Light is one of the most famous lighthouses in the country. Its construction was commissioned by President George Washington in 1787, and the light was first lighted in January of 1791.

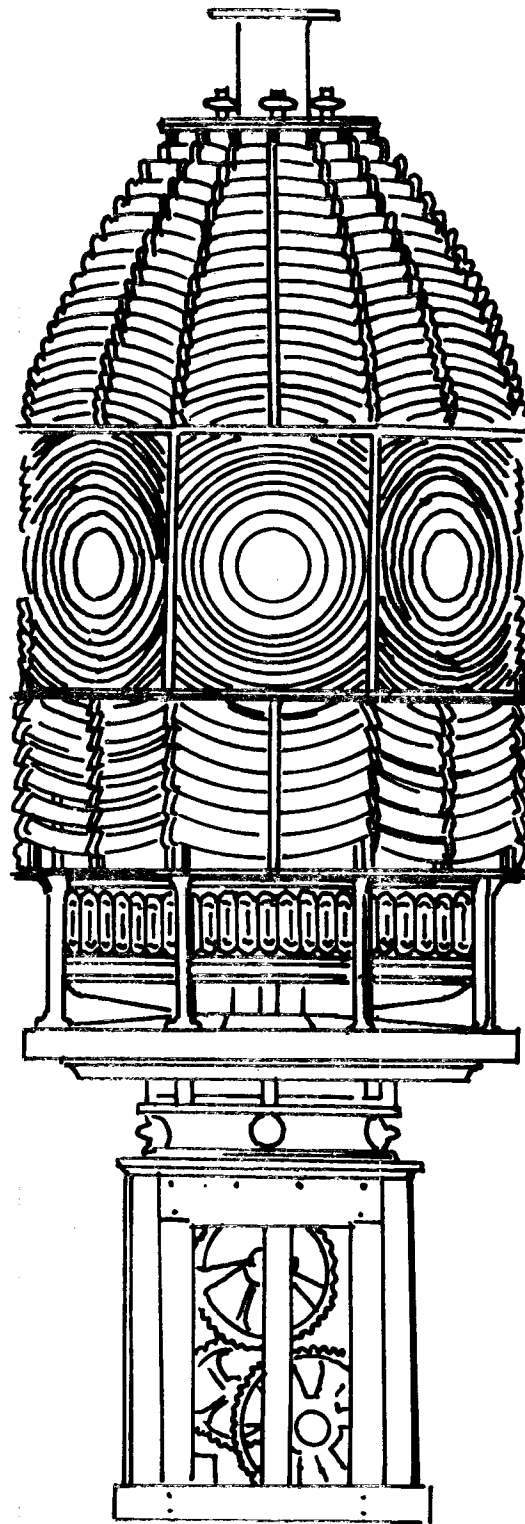

Old-fashioned Rotating Light

This lens rotates showing white flashes followed by red flashes. Notice all the brass parts on the lens.

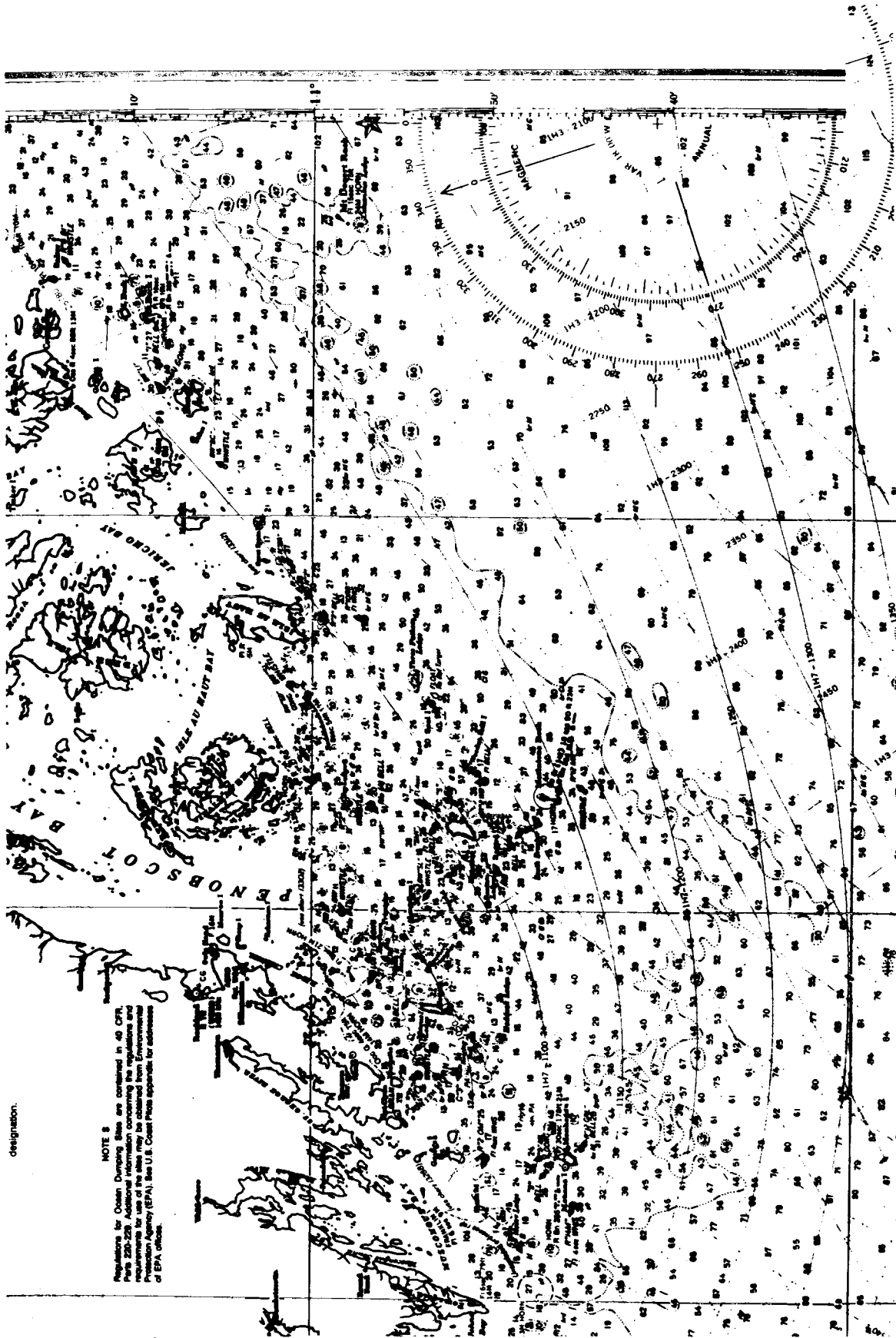
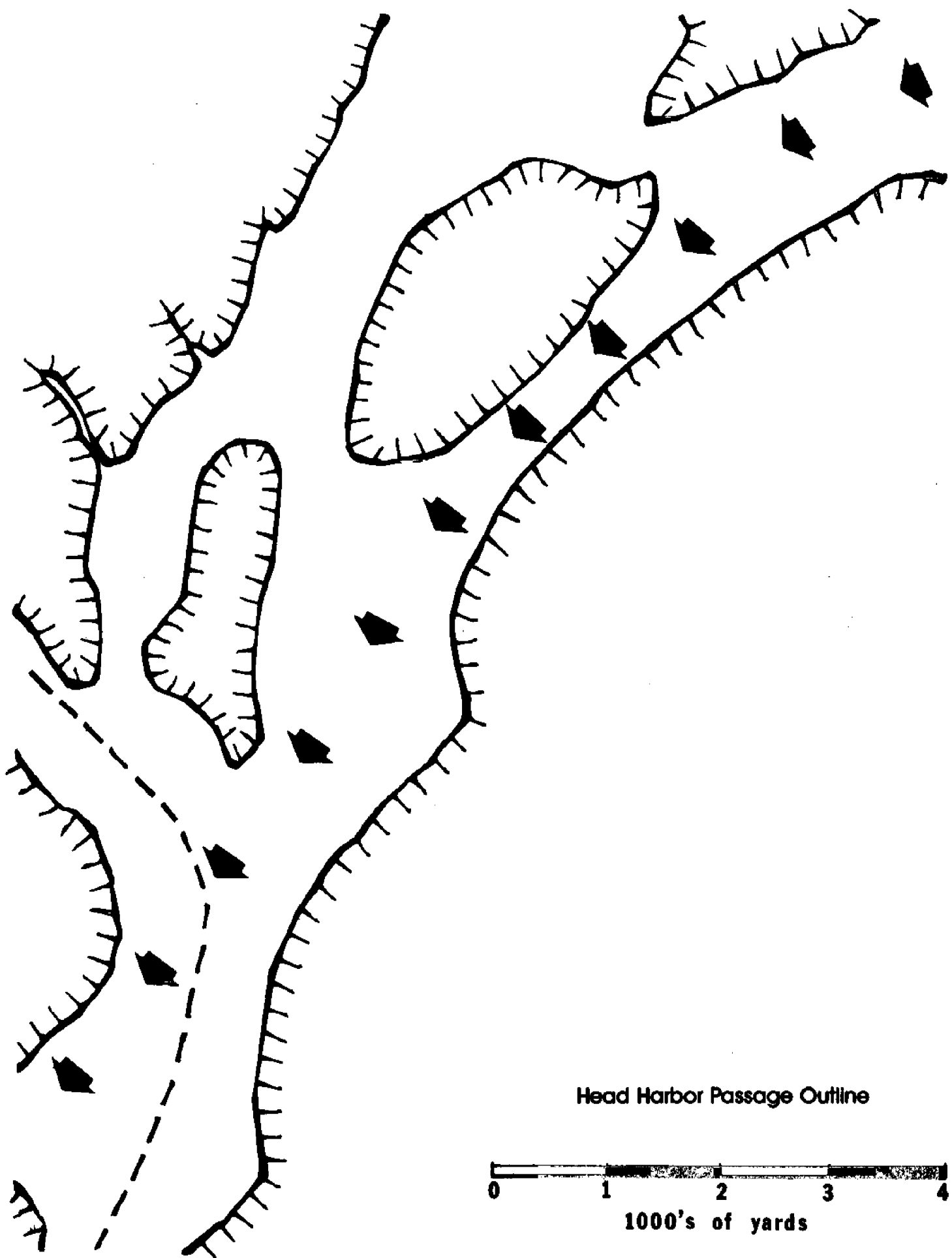
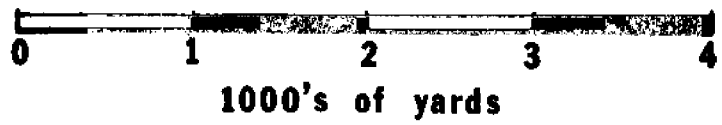
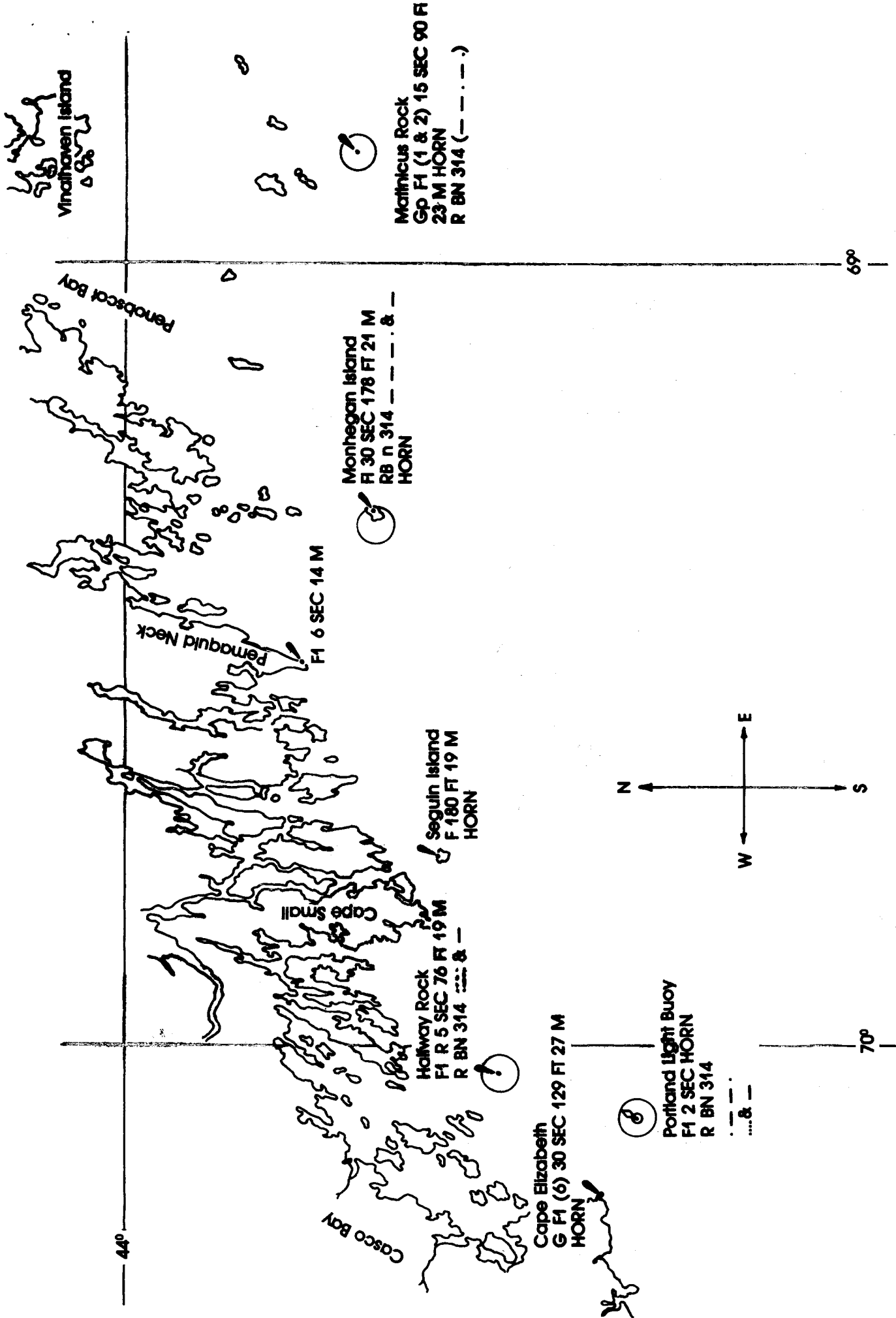

Chart Section of Puzzle Chart



Head Harbor Passage Outline





Simplified Chart: Cape Elizabeth to Mattinicus Rock

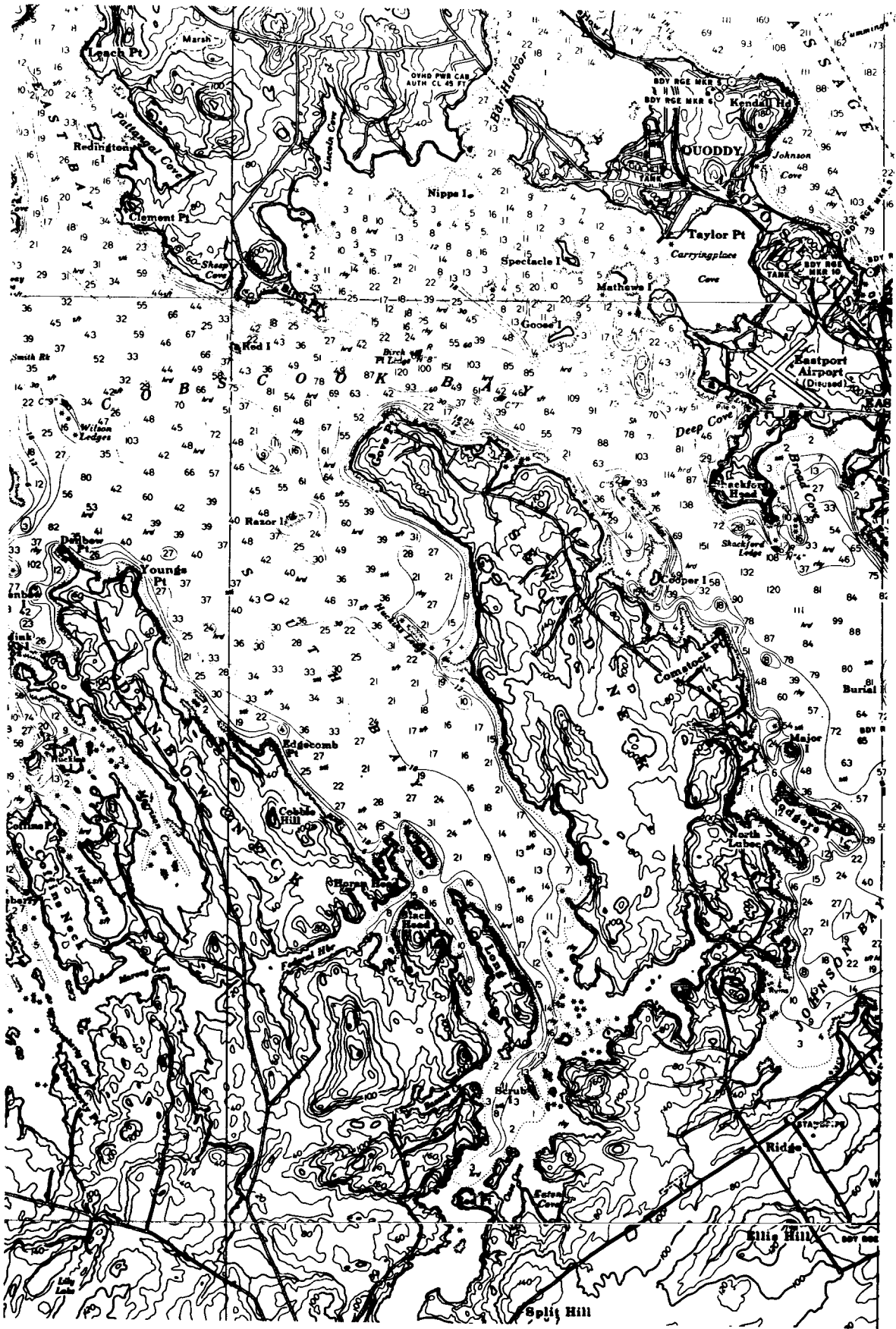

Chart Section of Cobscook Bay

Tide Table for Portland, Maine 1981

Times and Heights of High and Low Waters

| JULY | | | | | | AUGUST | | | | | | SEPTEMBER | | |
|------|--------------|------------------|-----|--------------|------------------|--------|--------------|------------------|-----|--------------|------------------|-----------|--------------|------------------|
| Day | Time h.m. | Height ft. m. | Day | Time h.m. | Height ft. m. | Day | Time h.m. | Height ft. m. | Day | Time h.m. | Height ft. m. | Day | Time h.m. | Height ft. m. |
| 1 | 0409 | -1.7 -0.5 | 16 | 0429 | 0.0 0.0 | 1 | 0539 | -1.3 -0.4 | 16 | 0514 | -0.6 -0.2 | 1 | 0025 | 9.7 3.0 |
| W | 1022 | 9.6 2.9 | Th | 1037 | 8.2 2.5 | Sa | 1150 | 9.4 2.9 | Su | 1122 | 9.0 2.7 | Tu | 0639 | -0.4 -0.1 |
| | 1619 | -0.6 -0.2 | | 1629 | 0.9 0.3 | | 1749 | -0.3 -0.1 | | 1721 | 0.0 0.0 | | 1249 | 9.2 2.8 |
| | 2234 | 11.2 3.4 | | 2241 | 9.4 2.9 | | | | | 2332 | 10.0 3.0 | | 1857 | 0.0 0.0 |
| 2 | 0502 | -1.8 -0.5 | 17 | 0505 | -0.2 -0.1 | 2 | 0003 | 10.4 3.2 | 17 | 0552 | -0.8 -0.2 | 2 | 0105 | 9.2 2.8 |
| Th | 1115 | 9.6 2.9 | F | 1114 | 8.3 2.5 | Su | 0625 | -1.1 -0.3 | M | 1202 | 9.3 2.8 | W | 0716 | 0.0 0.0 |
| | 1711 | -0.5 -0.2 | | 1708 | 0.7 0.2 | | 1236 | 9.3 2.8 | | 1804 | -0.3 -0.1 | | 1325 | 9.0 2.7 |
| | 2327 | 11.1 3.4 | | 2317 | 9.6 2.9 | | 1837 | -0.2 -0.1 | | | | | 1939 | 0.2 0.1 |
| 3 | 0555 | -1.7 -0.5 | 18 | 0543 | -0.4 -0.1 | 3 | 0049 | 10.1 3.1 | 18 | 0015 | 10.1 3.1 | 3 | 0147 | 8.8 2.7 |
| F | 1206 | 9.6 2.9 | Sa | 1151 | 8.5 2.6 | M | 0709 | -0.8 -0.2 | Tu | 0633 | -0.9 -0.3 | Th | 0755 | 0.4 0.1 |
| | 1805 | -0.4 -0.1 | | 1745 | 0.6 0.2 | | 1321 | 9.2 2.8 | | 1243 | 9.6 2.9 | | 1406 | 8.8 2.7 |
| | | | | 2356 | 9.7 3.0 | | 1923 | 0.1 0.0 | | 1848 | -0.5 -0.2 | | 2021 | 0.5 0.2 |
| 4 | 0019 | 10.8 3.3 | 19 | 0620 | -0.5 -0.2 | 4 | 0134 | 9.6 2.9 | 19 | 0059 | 10.0 3.0 | 4 | 0229 | 8.3 2.5 |
| Sa | 0646 | -1.5 -0.5 | Su | 1231 | 8.7 2.7 | Tu | 0752 | -0.3 -0.1 | W | 0715 | -0.9 -0.3 | F | 0835 | 0.8 0.2 |
| | 1259 | 9.4 2.9 | | 1827 | 0.4 0.1 | | 1406 | 9.0 2.7 | | 1328 | 9.8 3.0 | | 1448 | 8.6 2.6 |
| | 1857 | -0.1 0.0 | | | | | 2011 | 0.4 0.1 | | 1939 | -0.6 -0.2 | | 2106 | 0.8 0.2 |
| 5 | 0110 | 10.4 3.2 | 20 | 0036 | 9.8 3.0 | 5 | 0221 | 9.0 2.7 | 20 | 0149 | 9.8 3.0 | 5 | 0317 | 7.9 2.4 |
| Su | 0736 | -1.1 -0.3 | M | 0659 | -0.6 -0.2 | W | 0837 | 0.2 0.1 | Th | 0802 | -0.7 -0.2 | Sa | 0922 | 1.2 0.4 |
| | 1350 | 9.2 2.8 | | 1310 | 8.9 2.7 | | 1451 | 8.7 2.7 | | 1416 | 9.9 3.0 | | 1536 | 8.3 2.5 |
| | 1950 | 0.2 0.1 | | 1909 | 0.3 0.1 | | 2100 | 0.7 0.2 | | 2031 | -0.5 -0.2 | | 2159 | 1.0 0.3 |
| 6 | 0202 | 9.8 3.0 | 21 | 0120 | 9.7 3.0 | 6 | 0309 | 8.5 2.6 | 21 | 0242 | 9.4 2.9 | 6 | 0410 | 7.5 2.3 |
| M | 0827 | -0.6 -0.2 | Tu | 0740 | -0.6 -0.2 | Th | 0922 | 0.6 0.2 | F | 0853 | -0.4 -0.1 | Su | 1013 | 1.6 0.5 |
| | 1443 | 8.9 2.7 | | 1354 | 9.1 2.8 | | 1538 | 8.5 2.6 | | 1509 | 9.9 3.0 | | 1631 | 8.1 2.5 |
| | 2045 | 0.5 0.2 | | 1955 | 0.2 0.1 | | 2154 | 0.9 0.3 | | 2128 | -0.4 -0.1 | | 2258 | 1.2 0.4 |
| 7 | 0256 | 9.2 2.8 | 22 | 0208 | 9.5 2.9 | 7 | 0402 | 8.0 2.4 | 22 | 0340 | 9.0 2.7 | 7 | 0510 | 7.3 2.2 |
| Tu | 0916 | -0.1 0.0 | W | 0827 | -0.5 -0.2 | F | 1012 | 1.0 0.3 | Sa | 0949 | -0.1 0.0 | M | 1109 | 1.8 0.5 |
| | 1534 | 8.7 2.7 | | 1442 | 9.2 2.8 | | 1628 | 8.3 2.5 | | 1608 | 9.8 3.0 | | 1727 | 8.0 2.4 |
| | 2141 | 0.8 0.2 | | 2048 | 0.1 0.0 | | 2249 | 1.1 0.3 | | 2233 | -0.3 -0.1 | | 2358 | 1.2 0.4 |
| 8 | 0351 | 8.7 2.7 | 23 | 0259 | 9.3 2.8 | 8 | 0459 | 7.6 2.3 | 23 | 0444 | 8.7 2.7 | 8 | 0610 | 7.2 2.2 |
| W | 1009 | 0.4 0.1 | Th | 0915 | -0.3 -0.1 | Sa | 1104 | 1.4 0.4 | Su | 1050 | 0.2 0.1 | Tu | 1208 | 1.8 0.5 |
| | 1630 | 8.5 2.6 | | 1533 | 9.4 2.9 | | 1723 | 8.2 2.5 | | 1711 | 9.7 3.0 | | 1827 | 8.1 2.5 |
| | 2239 | 1.0 0.3 | | 2146 | 0.1 0.0 | | 2347 | 1.2 0.4 | | 2341 | -0.2 -0.1 | | | |
| 9 | 0448 | 8.2 2.5 | 24 | 0355 | 9.0 2.7 | 9 | 0558 | 7.4 2.3 | 24 | 0554 | 8.5 2.6 | 9 | 0058 | 1.1 0.3 |
| Th | 1102 | 0.8 0.2 | F | 1009 | -0.2 -0.1 | Su | 1200 | 1.6 0.5 | M | 1157 | 0.4 0.1 | W | 0709 | 7.4 2.3 |
| | 1721 | 8.4 2.6 | | 1629 | 9.5 2.9 | | 1819 | 8.2 2.5 | | 1818 | 9.7 3.0 | | 1306 | 1.6 0.5 |
| | 2338 | 1.1 0.3 | | 2248 | 0.0 0.0 | | | | | | | | 1924 | 8.4 2.6 |
| 10 | 0547 | 7.8 2.4 | 25 | 0458 | 8.8 2.7 | 10 | 0047 | 1.1 0.3 | 25 | 0050 | -0.3 -0.1 | 10 | 0151 | 0.8 0.2 |
| F | 1157 | 1.1 0.3 | Sa | 1108 | 0.0 0.0 | M | 0656 | 7.3 2.2 | Tu | 0704 | 8.5 2.6 | Th | 0801 | 7.7 2.3 |
| | 1818 | 8.4 2.6 | | 1729 | 9.7 3.0 | | 1255 | 1.6 0.5 | | 1304 | 0.4 0.1 | | 1359 | 1.3 0.4 |
| | | | | 2354 | -0.2 -0.1 | | 1913 | 8.4 2.6 | | 1924 | 9.8 3.0 | | 2013 | 8.8 2.7 |
| 11 | 0037 | 1.1 0.3 | 26 | 0605 | 8.7 2.7 | 11 | 0143 | 0.9 0.3 | 26 | 0154 | -0.5 -0.2 | 11 | 0238 | 0.4 0.1 |
| Sa | 0644 | 7.7 2.3 | Su | 1210 | 0.1 0.0 | Tu | 0751 | 7.5 2.3 | W | 0809 | 8.7 2.7 | F | 0847 | 8.1 2.5 |
| | 1249 | 1.3 0.4 | | 1832 | 9.9 3.0 | | 1348 | 1.5 0.5 | | 1407 | 0.3 0.1 | | 1446 | 0.8 0.2 |
| | 1907 | 8.5 2.6 | | | | | 2004 | 8.6 2.6 | | 2025 | 10.0 3.0 | | 2100 | 9.2 2.8 |
| 12 | 0130 | 0.9 0.3 | 27 | 0100 | -0.4 -0.1 | 12 | 0231 | 0.6 0.2 | 27 | 0254 | -0.8 -0.2 | 12 | 0323 | -0.1 0.0 |
| Su | 0740 | 7.6 2.3 | M | 0711 | 8.7 2.7 | Th | 0841 | 7.7 2.3 | Th | 0907 | 8.9 2.7 | Sa | 0932 | 8.6 2.6 |
| | 1338 | 1.3 0.4 | | 1313 | 0.1 0.0 | | 1436 | 1.3 0.4 | | 1507 | 0.1 0.0 | | 1531 | 0.3 0.1 |
| | 1956 | 8.6 2.6 | | 1933 | 10.2 3.1 | | 2049 | 8.9 2.7 | | 2121 | 10.2 3.1 | | 2144 | 9.6 2.9 |
| 13 | 0222 | 0.7 0.2 | 28 | 0203 | -0.8 -0.2 | 13 | 0316 | 0.3 0.1 | 28 | 0347 | -0.9 -0.3 | 13 | 0401 | -0.5 -0.2 |
| M | 0830 | 7.7 2.3 | Tu | 0815 | 8.8 2.7 | Th | 0926 | 8.0 2.4 | F | 0958 | 9.1 2.8 | Su | 1011 | 9.1 2.8 |
| | 1425 | 1.3 0.4 | | 1414 | 0.0 0.0 | | 1520 | 1.0 0.3 | | 1568 | -0.2 -0.1 | | 1614 | -0.2 -0.1 |
| | 2041 | 8.8 2.7 | | 2033 | 10.4 3.2 | | 2131 | 9.2 2.8 | | 2212 | 10.3 3.1 | | 2227 | 10.0 3.0 |
| 14 | 0307 | 0.4 0.1 | 29 | 0302 | -1.1 -0.3 | 14 | 0358 | 0.0 0.0 | 29 | 0435 | -1.0 -0.3 | 14 | 0441 | -0.8 -0.2 |
| Tu | 0916 | 7.8 2.4 | W | 0915 | 9.1 2.8 | F | 1006 | 8.3 2.5 | Sa | 1046 | 9.3 2.8 | M | 1051 | 9.6 2.9 |
| | 1510 | 1.2 0.4 | | 1513 | -0.2 -0.1 | | 1602 | 0.7 0.2 | | 1648 | -0.3 -0.1 | | 1657 | -0.7 -0.2 |
| | 2123 | 9.0 2.7 | | 2129 | 10.6 3.2 | | 2213 | 9.5 2.9 | | 2258 | 10.2 3.1 | | 2309 | 10.2 3.1 |
| 15 | 0349 | 0.2 0.1 | 30 | 0358 | -1.3 -0.4 | 15 | 0437 | -0.3 -0.1 | 30 | 0519 | -0.9 -0.3 | 15 | 0523 | -1.1 -0.3 |
| W | 0958 | 8.0 2.4 | Th | 1009 | 9.2 2.8 | Sa | 1043 | 8.6 2.6 | Su | 1129 | 9.4 2.9 | Tu | 1133 | 10.1 3.1 |
| | 1550 | 1.0 0.3 | | 1608 | -0.3 -0.1 | | 1640 | 0.3 0.1 | | 1730 | -0.3 -0.1 | | 1743 | -1.1 -0.3 |
| | 2203 | 9.3 2.8 | | 2222 | 10.7 3.3 | | 2253 | 9.8 3.0 | | 2344 | 10.0 3.0 | | 2355 | 10.3 3.1 |
| | | | 31 | 0450 | -1.4 -0.4 | | | | 31 | 0600 | -0.7 -0.2 | | | |
| | | | F | 1102 | 9.4 2.9 | | | | M | 1209 | 9.3 2.8 | | | |
| | | | | 1700 | -0.3 -0.1 | | | | | 1814 | -0.2 -0.1 | | | |
| | | | | 2313 | 10.7 3.3 | | | | | | | | | |

Time meridian 75° W. 0000 is midnight. 1200 is noon.
 Heights are referred to mean low water which is the chart datum of soundings.

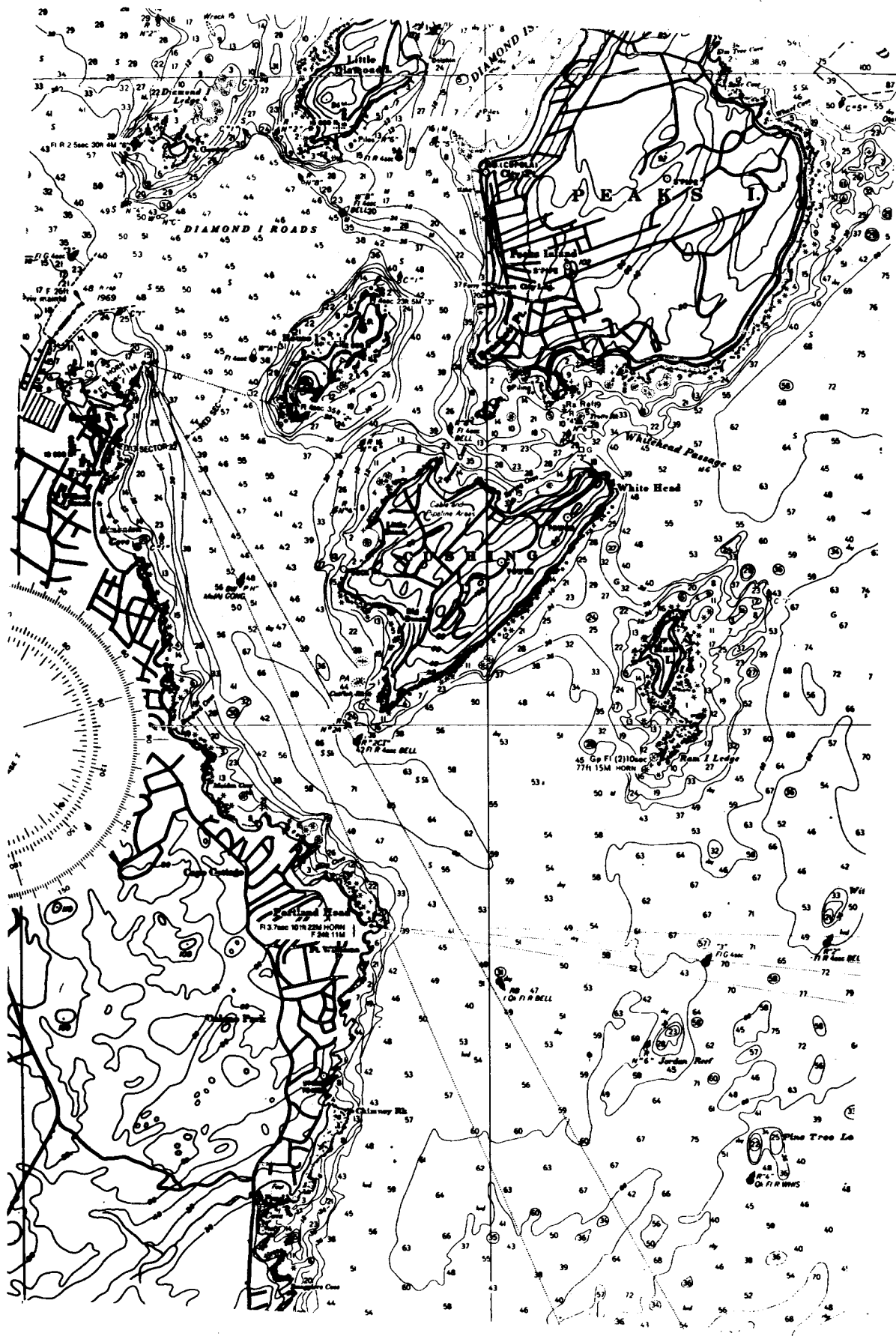

Chart Section of Portland Harbor

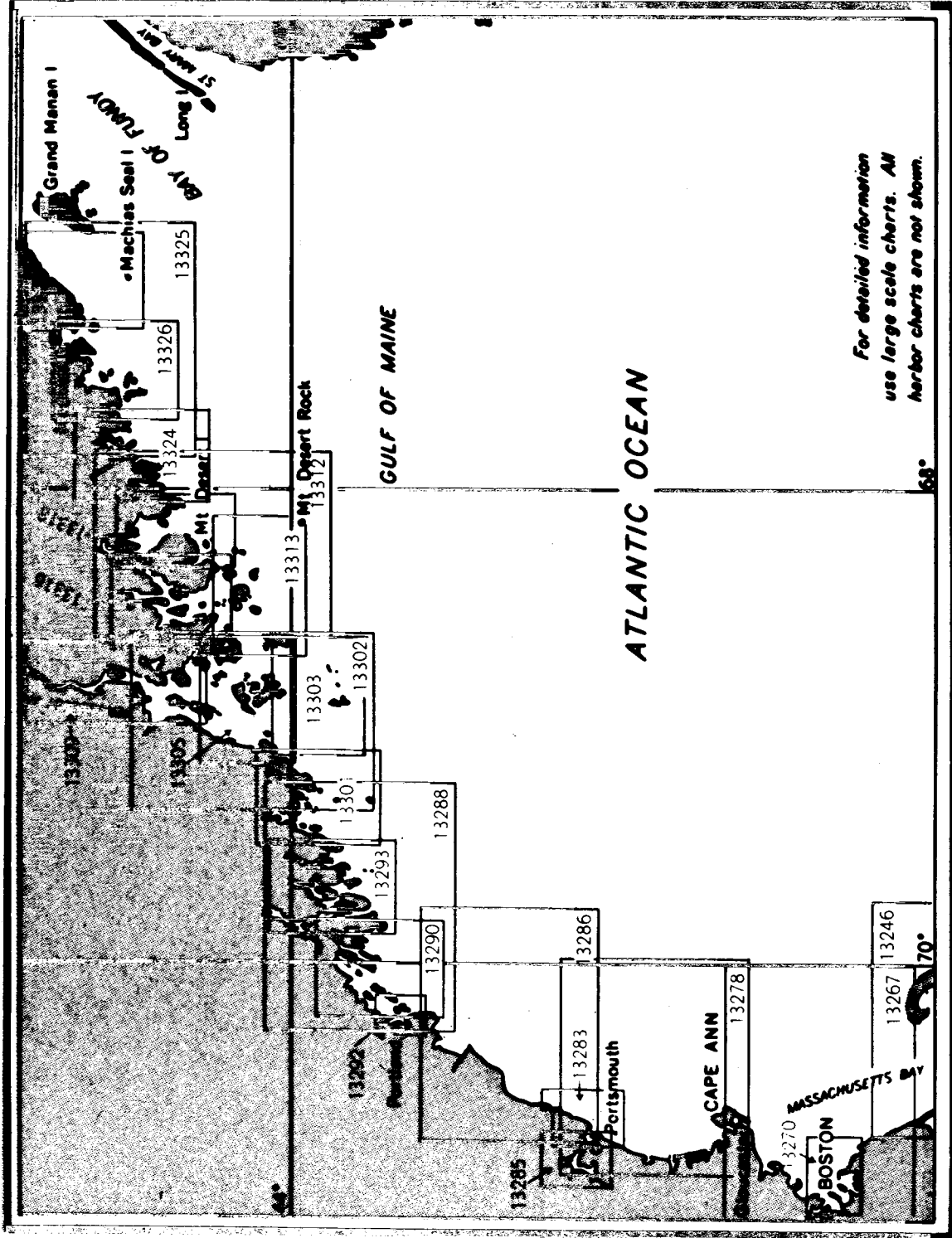

Chart Numbering System of the Gulf of Maine