

# **Environmental Monitoring Report for VoltturnUS Deployment in Castine, ME**

**Prepared for:**

U.S. Department of Energy

**University of Maine's Advanced Structures and Composites Center**

**Report Number: 16-2-890**

July 2, 2015

**Prepared by:**

Dr. Damian C. Brady,  
Assistant Professor

Maine Sea Grant Assistant Director for Research  
University of Maine  
193 Clark Cove Rd. Walpole, ME 04573  
damian.brady@maine.edu

**Reviewed by:**

Jeff Thaler,  
Asst. University Counsel &  
Visiting Professor Energy Law & Policy  
University of Maine Schools of Law & Economics  
246 Deering Ave, Room 512, Portland, ME 04102-2837  
jeffrey.thaler@maine.edu

## **Table of Contents**

<b>Summary of Deployment Monitoring.....</b>	<b>3</b>
<b>Appendix A: Supplemental Environmental Analysis.....</b>	<b>14</b>
<b>Appendix B: Finding of No Significant Impact.....</b>	<b>145</b>
<b>Appendix C: Fish and Wildlife Monitoring Plan.....</b>	<b>150</b>
<b>Appendix D: 2012 Pre-deployment Weekly Bird and Marine Mammal Observations.....</b>	<b>197</b>
<b>Appendix E: 2013 Deployment Weekly Bird and Marine Mammal Observations.....</b>	<b>302</b>
<b>Appendix F: Winter-Spring 2014 Deployment Weekly Bird and Marine Mammal Observations.....</b>	<b>379</b>
<b>Appendix G: Summer-Fall 2014 Deployment Weekly Bird and Marine Mammal Observations.....</b>	<b>443</b>
<b>Appendix H: 2012 Acoustic Bat Detection Survey.....</b>	<b>497</b>
<b>Appendix I: 2013 Acoustic Bat Detection Survey.....</b>	<b>514</b>
<b>Appendix J: 2014 Acoustic Bat Detection Survey.....</b>	<b>531</b>

---

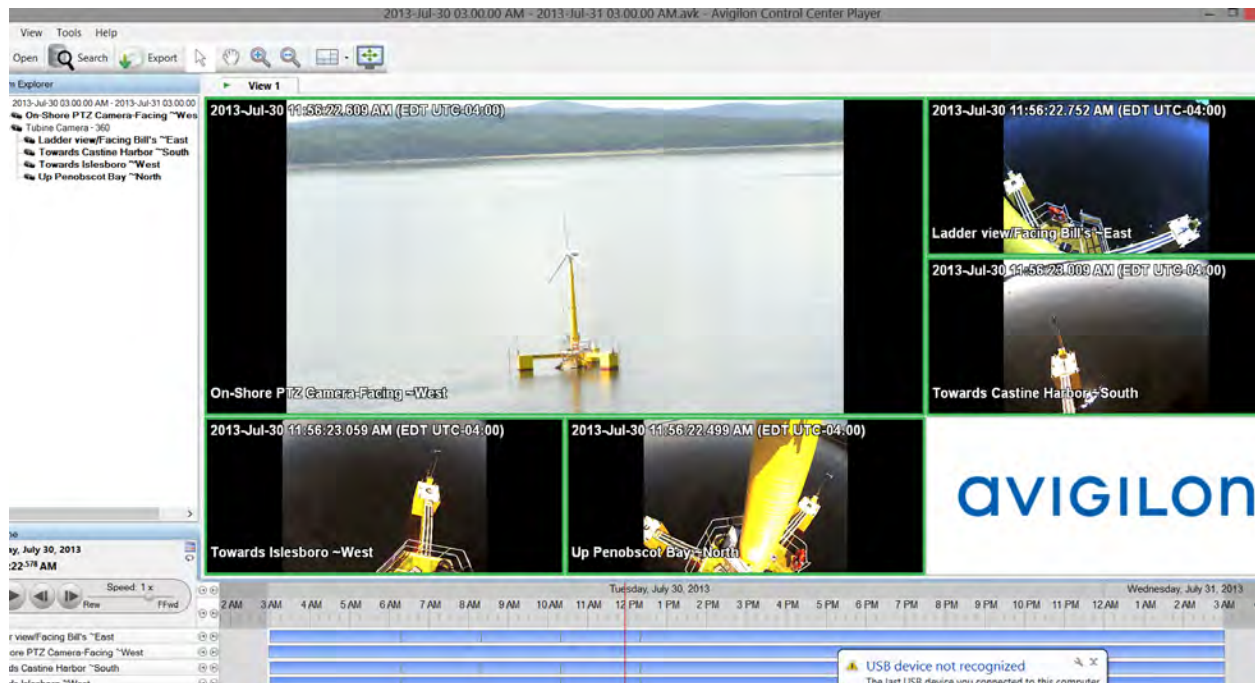
## Summary of Deployment Monitoring

On June 13<sup>th</sup>, 2013 the University of Maine's VoltturnUS 1:8 floating offshore wind turbine was energized and began delivering electricity through an undersea cable to the Central Maine Power electricity grid. Deployment continued until late November 2014. The following describes the results of extensive environmental monitoring at the Castine site. The primary observations of the site were derived from weekly visual surveys, bat echolocation detectors, underwater acoustic receivers, and web camera surveillance. The latter method consisted of observing the turbine and platform by web camera every 15-30 seconds throughout the deployment. If a bird was present in a 15-30 second snapshot, video footage was examined to determine if there was a collision.

Although a summary of the monitoring follows, one major finding was that there were no observed collisions. Also, there were no observed marine mammal haul outs (*i.e.*, no seals hauling out on the floating wind turbine platform). Environmental monitoring corroborated the Finding of No Significant Impact issued by the Department of Energy. Bat echolocation detectors were deployed near the site on a nearby lighthouse (in 2012 and 2013) and also on the turbine itself (in July-December 2014). This may be the first deployment of anabat detectors on a floating wind turbine to date. While these detectors would not be able to detect bat collisions, they can detect major shifts in habitat use. Results indicated a bat assemblage that did not change appreciably before and after the deployment of the floating turbine as measured by the number and type of calls. Unsurprisingly, the number of calls per night at the turbine were lower than those recorded at the lighthouse (the lighthouse being adjacent to foraging and roost habitat whilst the turbine was deployed over open water). Finally, NOAA deploys an acoustic array that listens for tagged Atlantic salmon, Atlantic and shortnose sturgeon. NOAA (James Hawkes, a research fishery biologist at the NOAA Orono Field Office) reported no change in the detection frequency on receivers located close to the wind turbine site. In sum, overall findings were consistent with the analyses described in the Draft Supplemental Environmental analysis (Appendix A) and the Department of Energy's Finding of No Significant Impact (Appendix B).

## Anti-Perching/Web Surveillance Monitoring

During the course of finalizing the Fish and Wildlife Monitoring plan (Appendix C) for the VoltturnUS 1:8 scale deployment, US Fish and Wildlife Service inquired as to the role of web surveillance in the University of Maine's monitoring program. In collaboration with US Fish and Wildlife, it was determined that the University of Maine would deploy a web camera adjacent to the VoltturnUS 1:8 turbine on the property of Bill Light (a local Castine resident supportive of the project). Although the Fish and Wildlife Monitoring Plan called for examining one image every 30 seconds during daylight hours, as part of a student project the analysis below examined images every 15 seconds. The spatial scope of the web surveillance included that air/water space of approximately 4 platform diameters in front and behind the turbine (Figure 1 shows the spatial coverage of monitoring). US Fish and Wildlife and Dr. Damian Brady viewed images on August 21<sup>st</sup> 2013 and agreed that the most important data to collect during this effort was information regarding how birds approached the turbine.



**Figure 1. Example of the video coverage of the VoltturnUS 1:8 scale turbine.**

The protocol used for this analysis was as follows: (1) if the screened image contained a bird, boat, or marine life, then the time was noted and recorded, (2) if possible, the bird, boat, or marine life was identified to subcategory (e.g., lobster boat or sail boat), (3) if the image contained a bird, it was categorized as near-field (i.e., very close to the camera), mid-field (i.e., potentially close to the turbine), or far field (i.e., distant from the turbine), and (4) mid-field images were further analyzed by examining the continuous video to determine if there was any bird-turbine interaction (e.g., collision, perching, etc.). The most important result of our analysis is that we have not observed (in weekly visual observations (see Boat-based Survey Results below) and the web camera monitoring) any collisions or marine mammal haul out. This type of monitoring was effective for a number of reasons, including event driven adaptive mitigation. In one example, a double crested cormorant visited the turbine on multiple days in mid-August 2014 (Figure 2), prompting the team to deploy bird deterrent on that area of the turbine. Interestingly, no birds were observed perching on the turbine since that event. That assessment applies both to the video observation and the weekly visual surveys. Another example of the use of this monitoring occurred on June 17, 2013, when US Fish and Wildlife Service informed Dr. Brady that an injured eagle had been located near Dice Head Lighthouse. The team was immediately able to review footage and determine there was no interaction with the turbine and that the turbine was only operating for 30 minutes on that day.



**Figure 2. Image of a double crested cormorant perching on the VoltturnUS 1:8th scale turbine in August 2013**

Another advantage of this technique in addition to its efficacy as a collision monitoring tool, is the ability to characterize human and wildlife activity at the site. For example, Figure 3 shows the seasonality of boat use at the site. Boat activity peaks in mid-to-late summer and this activity is primarily related recreation and lobstering. Outliers of boat activity can be observed on July 4<sup>th</sup> of 2013 and 2014. Under peak boating activity, it was common to observe more than 100 boats passing the turbine on a given day; a potentially important consideration if this type of monitoring were to continue in the future. Figure 4 also demonstrates that this observational technique can help determine peak of human activity at a floating turbine site. Peak boat activity occurred from 10:00-15:00.

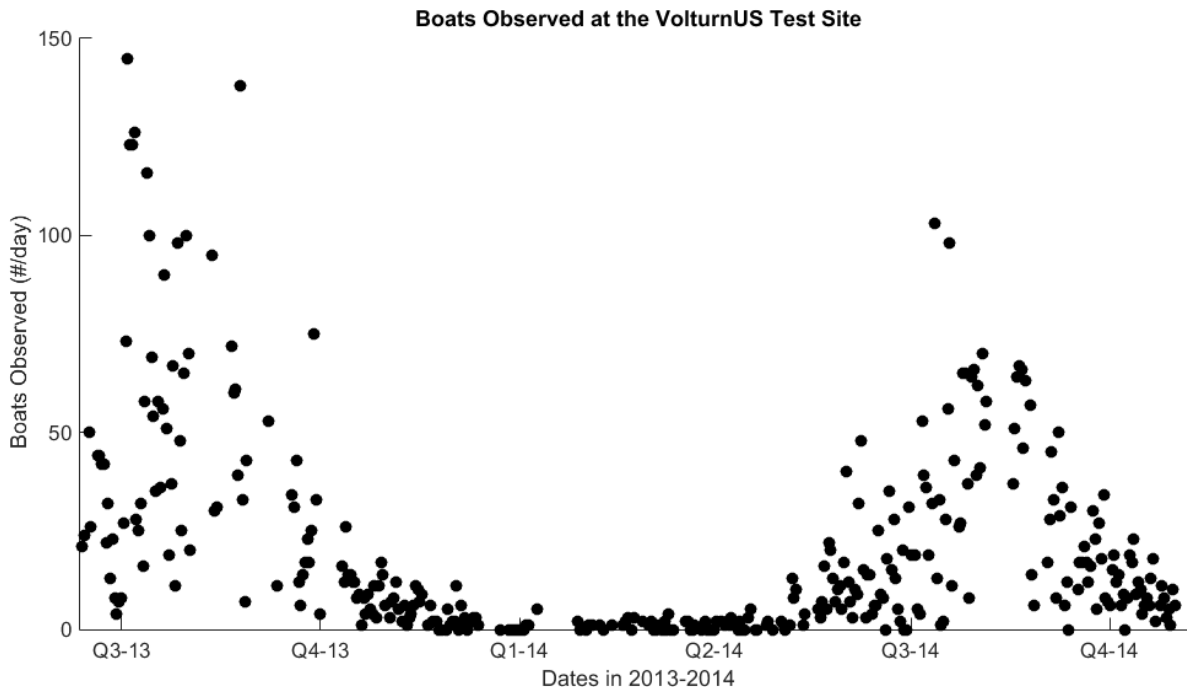


Figure 3. Number of boats observed each day from web surveillance of the VoltturnUS 1:8 scale deployment

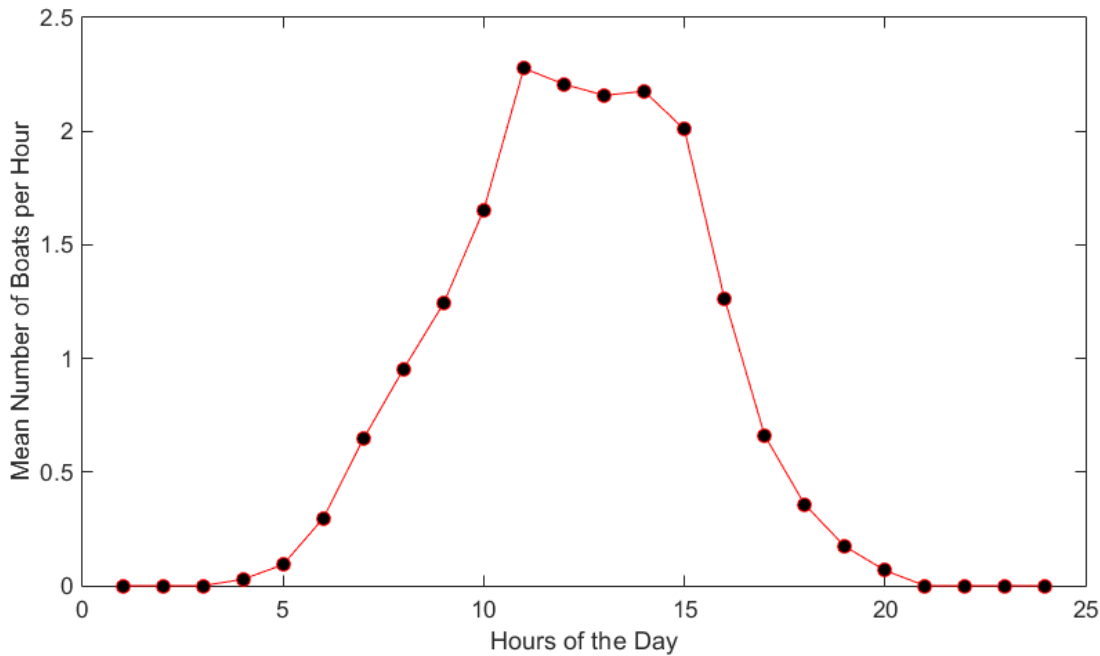
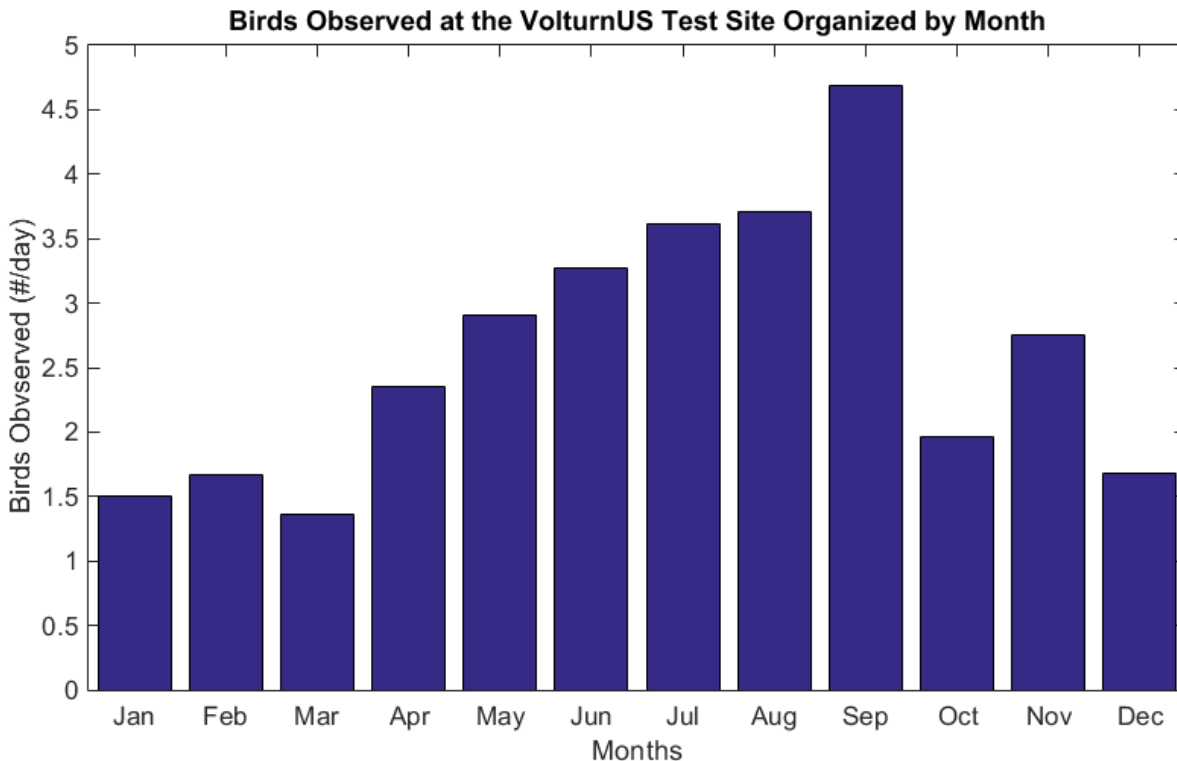
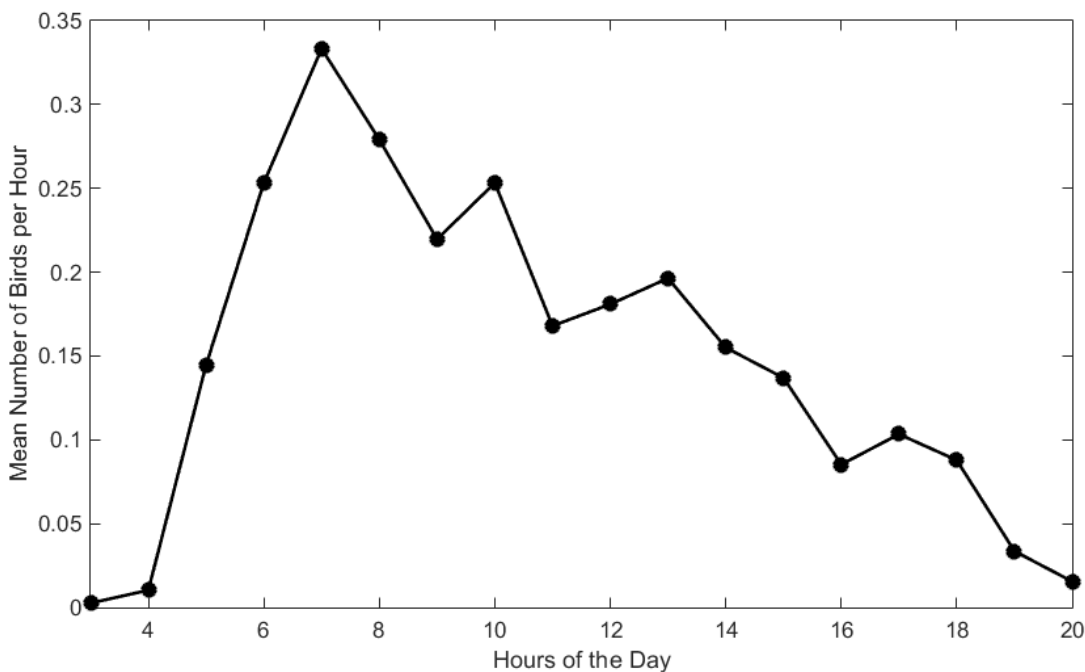


Figure 4. Number of observed boats organized by the hour. Most boat activity at this site occurs from 10am to 3pm.



**Figure 5. Number of birds observed per day organized by month at the VoltturnUS 1:8 scale**



**Figure 6. Bird activity at the VoltturnUS 1:8 scale Turbine organized by the hour**

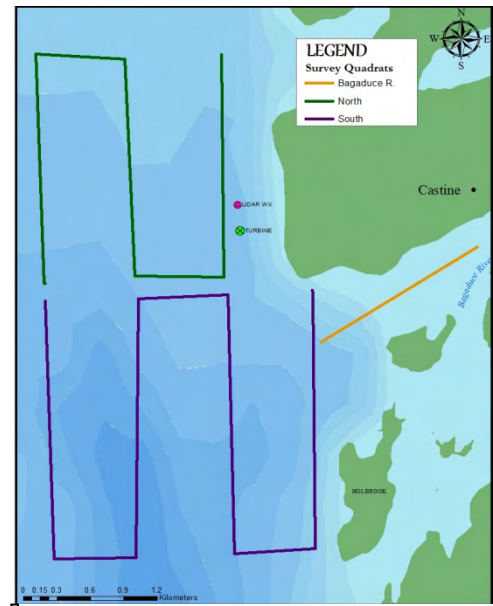
Bird activity as tracked by the web surveillance revealed a typical seasonal pattern of presence/absence. Bird activity reached its nadir in the winter months but interestingly, increased throughout the summer months to a peak in September, perhaps coinciding with fall migratory

activity. Another insight into bird use at the site was that peak bird activity occurred in the early hours of the morning, typically peaking at dawn and decreased throughout the day. There were no clear patterns of bird activity related to boat activity across the entire deployment; however, lobster boats passing the turbine would often be accompanied by herring gulls and other gull species. More analysis into the drivers of particular peaks in activity patterns, such as meteorological variables (e.g., air temperature, wind speed and direction, and precipitation), may be useful in future deployments in order to elucidate conditions conducive to very high bird activity. However, at the temporal scale of this deployment, macro-behavioral patterns consistent with summer habitat use/foraging and fall migration appear to dominate the observed time series.

## Boat Based Visual Observations for Birds and Marine Mammals

Boat-based visual observations of birds and marine mammals were conducted at the University of Maine’s Castine test site where the DeepCwind’s VoltturnUS 1/8 scale turbine test unit on a semi-submersible floating platform is located. Specific information pertaining to the flight heights, behaviors, and species found at this location were obtained which help to better understand the birds’ habitat use of the site (e.g., feeding, resting, and passing through the area). Map 1 shows the survey design for the transects, divided into three sections: surveys begin at the northeast corner of the “South” quadrat then proceed into the “North” quadrat (in which the floating turbine is located), and finish with the 1-mile drive into the “Bagaduce River” transect, where the survey ends. These data have provided essential components in the environmental assessment of this project. 17 surveys occurred in 2012 before the floating turbine was deployed in June of 2013, providing invaluable species and behavior data prior to human disturbance that will be used in future comparisons (see Appendix D for a full species list and results).

Throughout these surveys no birds were found dead and floating in the entire survey area, nor were collisions ever observed. Also, no birds or marine mammals were observed roosting, perching, or hauled out on the structure. Three marine mammal species (harbor seal, gray seal, and harbor porpoise) and more than 40 bird species were identified across the almost 60 surveys, with the most abundant avian species listed from greatest to lesser as the following: common eider (5.4 birds/km<sup>2</sup>), herring gull (5.3/km<sup>2</sup>), black guillemot (3.8/km<sup>2</sup>), Bonaparte’s gull (2.7/km<sup>2</sup>), ring-billed gull (2.1/km<sup>2</sup>), double-crested cormorant (1.1/km<sup>2</sup>), common loon (0.96/km<sup>2</sup>), and long-tailed duck (0.47/km<sup>2</sup>). As of December 2013 (see Appendix E for Species List, Behaviors, and More Information on the Deployment 2013 surveys), only one definite State Threatened (MESA) species was observed and included a total of nine razorbills (*Alca torda*; 0.03/km<sup>2</sup>). However, additional birds were observed that were unable to be specifically identified to the species, but may have included other Federal (FT or FT\*) or State Threatened (StTh or StTh\*), Federal (FE) or State Endangered (StE), or other federal and state-designated conservation status species (BCC: USFWS or SSC: MDIFW), as seen in Table 1. During the first half of 2014 (see Appendix F for



Map 1. Location of the survey quadrats used in the Castine Test Site with UMaine’s VoltturnUS 1/8<sup>th</sup> scale floating turbine and Lidar Weather Station.



2014 Winter/Spring Survey Species List, Behaviors, Densities, and More Information), eight other identified species or potential species of concern with a USFWS or MDIFW conservation designation were recorded such as bald eagles (*Haliaeetus leucocephalus*; BAEA), unidentified ducks, and other alcids. During the second half of 2014, great cormorants (*P. carbo*; GRCO) were the only identified state-threatened species of concern ( $n=2$ ,  $0.098/\text{km}^2$ ) in the area, although a single flock of 12 unidentified shorebirds that may or may not have been a Federally or State Threatened species were also recorded. Six other identified species of concern with a USFWS or MDIFW conservation designation were recorded (See Appendix G for a Full Species List, Behavioral Information and More Information). Although these species were present, no negative or close interaction with the VoltornUS was ever observed.

Temporal trends varied by the species type within the surveyed months of March through December. Typically the ducks, eider, scoters, and grebes were most present in the months of April and then again in October and November. Loons were the least abundant in June and August. Gull species were most abundant in June, September, October, and December, but terns were seen in very small abundance in June, peaking in July, and last seen in August. Alcids were least abundant in May through July and most abundant from August through December, consisting entirely of black guillemot except when razorbills and unidentified alcids appeared in December. Unidentified shorebird species were observed only in August and October. A few passerine species were observed only in April, May and July; however crows were present March through November, with highest abundances in March and October. Osprey were observed April through August, peaking in June, whereas a large number of unidentified hawks were recorded in September, likely associated with hawk migration. Marine mammals were consistently present, although peaks occurred in May and June, and then again from August through October. Bird behaviors included 49% sitting in the water, followed by 32% flying direct, and 14% were performing a behavior associated with active foraging. The most common flight height involved 37% of birds flying at one meter above the water, although 69% of all flying birds were at or below five meters.

There is very low risk for collision impact involving this single 1/8<sup>th</sup> scale floating turbine on a semi-submersible platform, even considering direct strike from the spinning blades. With a hub height measuring 50ft (15.24m) and a rotor diameter of 31.5ft (9.6m), the rotor-sweep zone spins at the 10-20m height. Flying within this zone involved only 20% of all birds; however, this is spread across the entire survey area and the largest portion was within the Bagaduce River (see Map 1 for the location of the river; which begins around Dice Head south of the turbine site). Any other potential attractant-effect of human boating activity or additional loafing structure appears negligible on the gull species. Although the gull species are consistently the only group of birds that are abundant enough and most often flying within the rotor-sweep zone to be the species of most concern for direct impacts, possible effects of reduced numbers in the region nearest the spinning turbine further reduces the concern.

### **Passive Acoustic Monitoring from Buoy by the BioDiversity Research Institute**

---

Although passive acoustic detection of birds was not a component of the Fish and Wildlife Monitoring Plan, a Maine Sea Grant award to Dr. Brady and the Biodiversity Research Institute allowed the team to experiment with a buoy-deployed passive acoustic detector to monitor birds and bats. The following represent the rationale for this project and preliminary results.

To achieve a greater understanding of offshore wildlife occurrence and movements in concert with an increased understanding of wind resources and environmental conditions the

Biodiversity Research Institute and the University of Maine began collaborating on a marine buoy system designed to gather detailed data on wind patterns as well as acoustic activity for birds and bats.

Marine wildlife acoustic data were collected continuously from May – November 2013 off the coast of Castine, ME. A subset of days was selected for further analysis of bird and bat acoustics to determine if the platform was effectively recording data. Standard acoustic detectors were able to consistently identify songbird flight calls (short, relatively high calls that can be difficult to capture effectively) as well as nearby territorial songbirds' calls and seabird calls during the day. Diversity of migrating songbirds was high early in the fall and we were able to identify a species under a variety of environmental conditions and evenings. In the initial analysis of the ultrasonic bat acoustic data, we found that high frequency interference from the buoy's other data collecting devices made bat detection and identification impossible.

The ability to detect and identify songbird and seabird vocalizations was reasonable and equivalent to similar work conducted in the terrestrial environment. While more work needs to be conducted on achieving better bat acoustic results, we are confident that the necessary improvements can be made to increase the efficiency of this detector. The University of Maine is committed to exploring new technology for monitoring the offshore environment which will necessarily include the ability to deploy monitoring equipment under marine conditions in close proximity to acoustic noise.

## **Bat Monitoring**

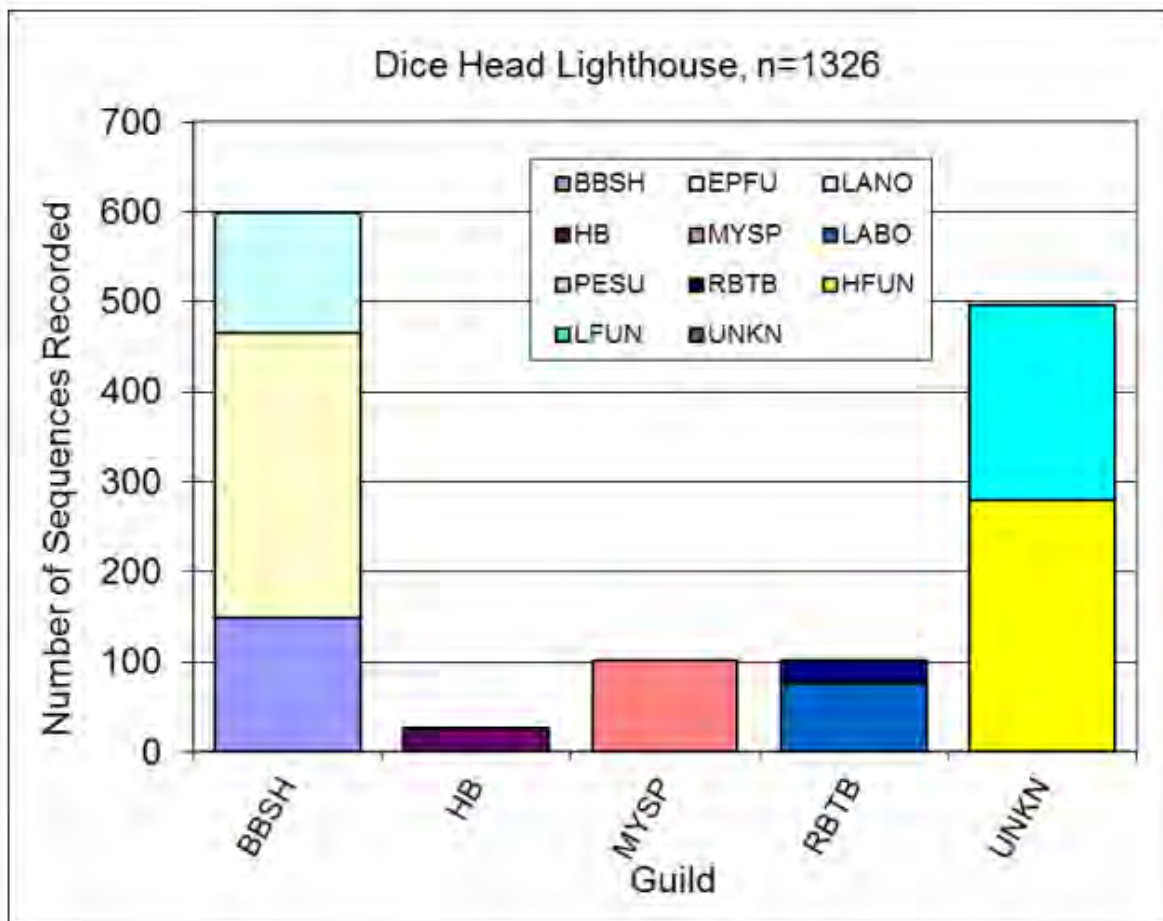
---

Two SD-1-based acoustic detectors were deployed on Dice Head Lighthouse by Stantec. Below is a brief summary of their findings from May-October 2013 and July-December 2014 (the detector was removed at approximately the period when bats begin to hibernate).

The DeepCWind Consortium, led by the University of Maine, installed a prototype of a floating wind turbine in the waters of Penobscot Bay near Castine, Maine. Aligned with this effort, Stantec Consulting Services, Inc. (Stantec) conducted a separate deployment year of acoustic monitoring of bats from the tower of the Dice Head Lighthouse in Castine, the nearest feasible monitoring location to the site at which the test turbine is to be deployed (see Appendix H for an in depth report of the 2012 findings). Survey methods were replicated in 2013 at this same location (see Appendix I for more in depth information on the results of the 2013 acoustic bat survey), and followed those used by similar assessments of bat activity conducted by Stantec in the Gulf of Maine since 2009. Additionally, a year of monitoring was performed with the acoustic detector deployed on the turbine itself (see Appendix J for an in depth report of the on turbine bat survey). The following represents summary findings from Stantec's deployment reporting available in Appendices H-J:

An acoustic detector was deployed on the tower of the Dice Head Lighthouse on May 14, 2013, and operated on a nightly basis through the night of October 11, 2013. A total of 1,326 bat call sequences were recorded during this 151-night period. Between 0 and 103 call sequences were recorded per night, with an overall activity level of 8.8 call sequences per detector-night. Bats were detected during 126 out of the 151 surveyed nights (83%). Of the 1,326 recorded call sequences, 829 (63%) were identified to species or guild and the remaining 497 call fragments were either too short, or lacked sufficient characteristic detail to be identified to species, and were classified as either high frequency or low frequency "unknown." The BBSH guild, including the big brown bat (*Eptesicus fuscus*) and silver-haired bat (*Lasionycteris noctivagans*)

was the most frequently identified guild, followed by a similar level of detected activity from both the Myotis and RBTB (including the eastern red bat [*Lasiurus borealis*] and tricolored bat [*Perimyotis subflavus*]) guilds (Figure 6).



**Figure 7. Number of sequences recorded by guild. BBSH, HB, PESU, LFUN, EPFU, MYSP, RBTB, UNKN, LANO, LABO, and HFUN refer to big brown/silver haired bat, hoary bat, tri-colored bat, “low frequency unknown”, big brown bat, Myotis, Eastern red/tri-colored bat, “unknown”, silver-haired bat, Eastern red bat, and “high frequency unknown”, respectively.**

Bat fatality rates at terrestrial windpower sites are typically highest during the fall migratory period. The 2012 surveys conducted at the Dice Head lighthouse only documented bat activity during the summer residency period, from May to mid-July. In order to measure activity during the more vulnerable fall migratory period, the 2013 acoustic survey period was extended into mid-October. Similar to the 2012 data, bats in 2013 were found to be present on most nights from May–July; this activity likely represents the local foraging of resident bats. Both the nightly range in activity levels and variability among survey nights are typical of this type of survey. A comparison of monthly detection rates suggests that Myotis species and big brown bats are most active during the months of June and July, followed by declining monthly detection rates from August to mid-October. Conversely, the migratory tree bats, including the hoary bat, red bat, and silver-haired bats had relatively low monthly detection rates from May–July, but recorded the

highest monthly detection rate in August. The largest night of bat activity was recorded on August 29, and was well above the overall nightly average call rate of 8.8 C/D/N. Eighty-five of the 103 calls recorded on 29 August were identified as big brown bat calls, and 84 of those big brown calls were recorded within 1 hour of sunset. This large pulse of activity is most likely a bout of foraging driven by possibly ideal conditions.

#### *On-Turbine Deployment in 2014 (Appendix J):*

An acoustic detector system consisting of primary and backup detectors was deployed on the VoltturnUS prototype wind turbine on July 17, 2014. The detector was fixed to the side of the tower at a height of approximately 5.5 meters above the water. The primary detector operated on a nightly basis through the night of December 17, 2014. A total of 277 bat call sequences were recorded during this 154-night period. Between 0 and 40 call sequences were recorded per night, with an overall activity level of 3.0 call sequences per detector-night during the period between July 15 and October 15 (a period used for seasonal comparisons in other studies). Bats were detected during 56 of the 91 nights (62%) surveyed between July 15 and October 15. Of the 277 recorded call sequences, 170 (61%) were identified to species or guild and the remaining 107 call fragments were either too short, or lacked sufficient characteristic detail to be identified to species, and were classified as either high frequency or low frequency “unknown.” The BBSH guild, including the big brown bat (*Eptesicus fuscus*) and silver-haired bat (*Lasionycteris noctivagans*) was the most frequently identified guild, followed by RBTB (including the eastern red bat [*Lasiurus borealis*] and tricolored bat [*Perimyotis subflavus*]) guilds. Least frequently identified and with a similar level of detected activity were *Myotis spp.* and hoary bat (*Lasiurus cinereus*) guilds.

Bat activity occurred during more than half of nights monitored between July 15 and October 15. As such, bat presence at the prototype turbine was relatively consistent during this period and not unlike those documented at a series of offshore structures monitored as part of the regional offshore acoustic survey conducted by Stantec between 2009 and 2011 and between 2012 and 2014. Acoustic monitoring at a weather buoy (NERACOOS Buoy F) in the same vicinity as the prototype turbine documented detection rates of 3.04 passes per night during the period from 15 July through 15 October 2013, with bats detected during 57% of surveyed nights within this period, which are remarkably similar to the rates documented in 2014 at the turbine. Similarly, the Gini Coefficient of 0.69 calculated for the prototype turbine was similar to that of 0.71 calculated for the buoy. The Gini Coefficients calculated for acoustic survey results at 4 additional buoys monitored in the Gulf of Maine between 2011 and 2014 were all higher than that calculated for the prototype turbine (indicating more consistent activity at the turbine), although these buoys were all substantially more remote than the prototype turbine. Nevertheless, seasonal timing of acoustic bat activity documented at the prototype turbine was similar to that documented at a variety of other offshore structures in the Gulf of Maine that were monitored using similar methods by Stantec between 2009 and 2014.

## **Conclusion**

Over the period of deployment of over 17 months, there were no observed collisions, nor any observed marine mammal haul outs (*i.e.*, no seals hauling out on the floating wind turbine platform). The extensive environmental monitoring efforts documented herein corroborated the Finding of No Significant Impact issued by the Department of Energy. Bat echolocation detector results indicated a bat assemblage that did not change appreciably before and after the deployment of the floating turbine as measured by the number and type of calls. Unsurprisingly,

the number of calls per night at the turbine were lower than those recorded at the lighthouse (the lighthouse being adjacent to foraging and roost habitat whilst the turbine was deployed over open water). Finally, NOAA (James Hawkes, a research fishery biologist at the NOAA Orono Field Office) reported no change in the detection frequency on receivers located close to the wind turbine site for tagged Atlantic salmon, Atlantic and shortnose sturgeon.

In sum, overall findings were consistent with the analyses described in the Draft Supplemental Environmental analysis (Appendix A) and the Department of Energy's Finding of No Significant Impact (Appendix B).

---

**FINAL SUPPLEMENTAL  
ENVIRONMENTAL ASSESSMENT  
FOR THE  
  
UNIVERSITY OF MAINE'S DEEPWATER  
OFFSHORE FLOATING WIND TURBINE  
TESTING AND DEMONSTRATION PROJECT**

**Castine**

**US Department of Energy  
Office of Energy Efficiency and Renewable Energy  
Golden, Colorado**



**March 2013**

---

## ACRONYMS AND ABBREVIATIONS

CMP	Central Maine Power
CFR	Code of Federal Regulations
DMR	Maine Department of Marine Resources
DOE	U.S. Department of Energy
DPS	distinct population segment
EA	environmental assessment
EFH	essential fish habitat
EMAP	Environmental Monitoring and Assessment Program
EMF	electromagnetic field
EPA	U.S. Environmental Protection Agency
ESA	Endangered Species Act
FAD	fish aggregation device
MSA	Magnuson-Stevens Fishery Conservation Act
NEPA	National Environmental Policy Act
NMFS	National Marine Fisheries Service
NOAA	National Oceanic and Atmospheric Administration
NREL	National Renewable Energy Laboratory
PVC	polyvinyl chloride
ROW	right-of-way
SHPO	State Historic Preservation Office
UMaine	University of Maine
U.S.C.	United States Code
USCG	U.S. Coast Guard
USFWS	U.S. Fish and Wildlife Service

**CONTENTS**

1. INTRODUCTION ..... 1

    1.1 National Environmental Policy Act Requirements ..... 1

    1.2 Background ..... 1

    1.3 Purpose and Need..... 2

    1.4 Public and Agency Involvement ..... 4

        1.4.1 UMaine Public Involvement..... 4

        1.4.2 DOE Agency Consultation and Public Involvement ..... 4

        1.4.3 Draft Supplemental Environmental Assessment ..... 5

2. PROPOSED ACTION AND ALTERNATIVES ..... 6

    2.1 DOE’s Proposed Action..... 6

    2.2 University of Maine's Proposed Project..... 6

        2.2.1 Overview..... 6

        2.2.2 Wind Turbine and platform ..... 8

        2.2.3 Mooring and Anchoring System..... 8

        2.2.4 Electrical Interconnection ..... 11

        2.2.5 Installation ..... 11

        2.2.6 Operations and Maintenance ..... 13

        2.2.7 Removal..... 14

    2.3 No Action Alternative..... 15

    2.4 Required Agency Permits and Approval Types..... 15

    2.5 Applicant-Committed Measures ..... 16

        2.5.1 Biological Resources ..... 16

        2.5.2 Ocean and Land Use..... 16

        2.5.3 Cultural Resources..... 17

3.0 AFFECTED ENVIRONMENT AND ENVIRONMENTAL IMPACTS..... 18

    3.1 Environmental Categories Evaluated and Dismissed From Further Analysis ..... 18

        3.1.1 Geophysical Resources ..... 18

        3.1.2 Water Resources ..... 18

        3.1.3 Electromagnetic Fields ..... 18

        3.1.4 Aesthetic Resources..... 19

        3.1.5 Socioeconomics and Environmental Justice..... 19

        3.1.6 Intentional Destructive Acts ..... 20

    3.2 Biological Resources..... 20

        3.2.1 Affected Environment ..... 20

        3.2.2 Environmental Impacts Related to Biological Resources ..... 30

        3.2.3 No-Action Alternative ..... 38

    3.3 Noise and Vibration ..... 38

        3.3.1 Affected Environment ..... 38

        3.3.2 Environmental Impacts Related to Noise and Vibration ..... 39



3.3.3	No-Action Alternative .....	41
3.4	Ocean and Land Use .....	41
3.4.1	Affected Environment .....	41
3.4.2	Environmental Impacts Related to Ocean and Land Use .....	43
3.4.3	No-Action Alternative .....	46
3.5	Cultural Resources .....	46
3.5.1	Affected Environment .....	46
3.5.2	Environmental Impacts Related to Cultural Resources .....	48
3.5.3	No-Action Alternative .....	49
3.6	Irreversible and Irretrievable Commitments of Resources .....	50
3.7	The Relationship Between Local Short-Term Uses of the Human Environment and the Maintenance and Enhancement of Long-Term Productivity .....	50
4.0	CUMULATIVE IMPACTS .....	51
5.0	REFERENCES .....	52

**LIST OF TABLES**

Table 2-1.	Mooring and anchoring dimensions and description. ....	9
Table 2-2.	Required permits and approvals. ....	15
Table 3-1.	Summary of fish species most commonly captured in the Maine-New Hampshire Inshore Trawl Survey in or near Penobscot Bay, May 2010. ....	23
Table 3-2.	Marine species and life stages for which Essential Fish Habitat occurs in the portion of Penobscot Bay that includes Castine. ....	24
Table 3-3.	Most common bird species observed offshore of Castine. ....	26
Table 3-4.	Bird species listed under the Maine Endangered Species Act. ....	27

**LIST OF FIGURES**

Figure 1-1.	Proposed location of deployment of floating offshore wind turbine platform. ....	3
Figure 2-1.	Anticipated dimensions of the proposed floating offshore wind turbine to be deployed at Castine. ....	7
Figure 2-2.	Dimensions of proposed anchor for Castine floating turbine deployment (left) and typical boat anchor for vessels up to 83 feet long (right). ....	9
Figure 2-3.	Elevation view of the proposed mooring line design (not to scale). ....	10
Figure 2-4.	Alternative gravity anchor. ....	11
Figure 3-1.	View of the property where the onshore cable would be deployed, looking toward shore (top) and inland (bottom). ....	21
Figure 3-2.	Locations of most recent bald eagle nest sites in project vicinity (210B and 210D). ....	28
Figure 3-3.	Flight heights for bird species observed during UMaine 2012 visual surveys. ....	35
Figure 3-4.	NOAA chart (13302) showing Recommended Vessel Routes (green shade) in upper Penobscot Bay. ....	43
Figure 3-5.	Castine Historic District (rectangle). ....	47
Figure 3-6.	View from the base of Dyce Head Lighthouse toward the shore. ....	49

**APPENDICES**

**APPENDIX A: CONSULTATION LETTERS**

## 1. INTRODUCTION

### 1.1 National Environmental Policy Act Requirements

The *National Environmental Policy Act* [42 United States Code (U.S.C.) 4321 *et seq.*; NEPA], the Council on Environmental Quality's NEPA regulations [40 *Code of Federal Regulations* (CFR), Parts 1500 to 1508], and the U.S. Department of Energy's (DOE's) NEPA implementing procedures (10 CFR Part 1021) require that DOE consider the potential environmental impacts of a proposed action before making a decision. The proposal to provide federal financial support is considered a federal action and, therefore, is subject to the procedural requirements of the NEPA and DOE's NEPA. To comply with NEPA, DOE has determined the need to prepare a supplemental environmental assessment (EA) to evaluate the potential impacts that could result from their Proposed Action. The provision of financial assistance for the Proposed Project is conditional upon the completion of the NEPA process whereupon a final decision would then be made by DOE.

In compliance with these regulations, this Supplemental EA:

- Examines the potential environmental impacts of the Proposed Action and the No-Action Alternative;
- Identifies unavoidable adverse environmental impacts of the Proposed Action;
- Describes the relationship between local short-term uses of the human environment and the maintenance and enhancement of long-term productivity; and
- Characterizes any irreversible and irretrievable commitments of resources that would be involved should DOE decide to implement its Proposed Action.

DOE must meet these requirements before it can make a final decision to proceed with any proposed federal action that could cause adverse impacts to human health or the environment. This Supplemental EA provides DOE and other decision makers the information needed to make an informed decision about the temporary installation, operation, and eventual removal of a proposed reduced-scale wind turbine at the Castine site described below. The Supplemental EA evaluates the potential individual and cumulative impacts of the proposed project. For purposes of comparison, this Supplemental EA also evaluates the impacts that could occur if DOE did not provide funding (the No-Action Alternative) under which DOE assumes the project would not proceed.

### 1.2 Background

DOE is proposing to authorize the expenditure of Congressionally Directed federal funding by the University of Maine (UMaine) to deploy, test, and retrieve one small-scale floating turbine

offshore of Castine, in Hancock County, Maine, as part of UMaine's DeepCwind Consortium Research Program. DOE has previously authorized the expenditure of federal funding by UMaine to conduct similar deployment, testing, and retrieval activities at the UMaine Deepwater Offshore Wind Test Site at Monhegan Island, Maine (Monhegan test site).

UMaine originally planned to fabricate and temporarily deploy up to two, 1/3-scale turbines within the Monhegan test site. DOE completed an Environmental Assessment (DOE/EA-1792, DOE 2011) and determined a Finding of No Significant Impact regarding that project in September 2011. The EA for the Monhegan test site is incorporated by reference. UMaine has since proposed to downscale the size of the tower and turbine from 1/3 scale to 1/8 scale. Because of this change to a smaller size, for part of the year UMaine is proposing to deploy the tower and turbine at a more sheltered nearshore location just west of Castine, Maine (Figure 1-1) (Castine site).

DOE prepared this Supplemental EA to evaluate the potential environmental impacts of providing funding to UMaine for their proposed wind turbine platform testing at Castine. In compliance with NEPA and its implementing procedures, this Supplemental EA examines the potential environmental effects of DOE's Proposed Action (authorizing UMaine to expend Congressionally Directed federal funds), UMaine's proposed project, and the No-Action Alternative (if DOE chooses not to provide financial assistance for this project). The purpose of this Supplemental EA is to inform DOE and the public of the potential environmental impacts of the proposed project and the alternatives.

DOE reviewed the DOE/EA-1792 that described the potential effects of UMaine deploying up to two 1/3-scale platforms and wind turbines at the Monhegan test site (DOE 2011), and concluded that effects to the environment from deploying a single 1/8-scale turbine in that area following deployment in Castine would be similar to or less than that described in the EA for the Monhegan test site. Therefore, UMaine's proposal to deploy the 1/8-scale turbine near Monhegan Island is not discussed in this Supplemental EA, though cumulative impacts related to both deployments and additional foreseeable activities are discussed in Chapter 4.

### **1.3 Purpose and Need**

The DOE Office of Energy Efficiency and Renewable Energy's Wind and Water Power Program supports the development and deployment of advanced wind and water power devices, including the advancement of offshore wind technologies and floating offshore wind turbine platforms. One goal of the program is to help industry harness the renewable, emissions-free offshore wind resource to generate environmentally sustainable and cost-effective electricity. To meet this goal, DOE supports the design and development of offshore wind technologies as well as the

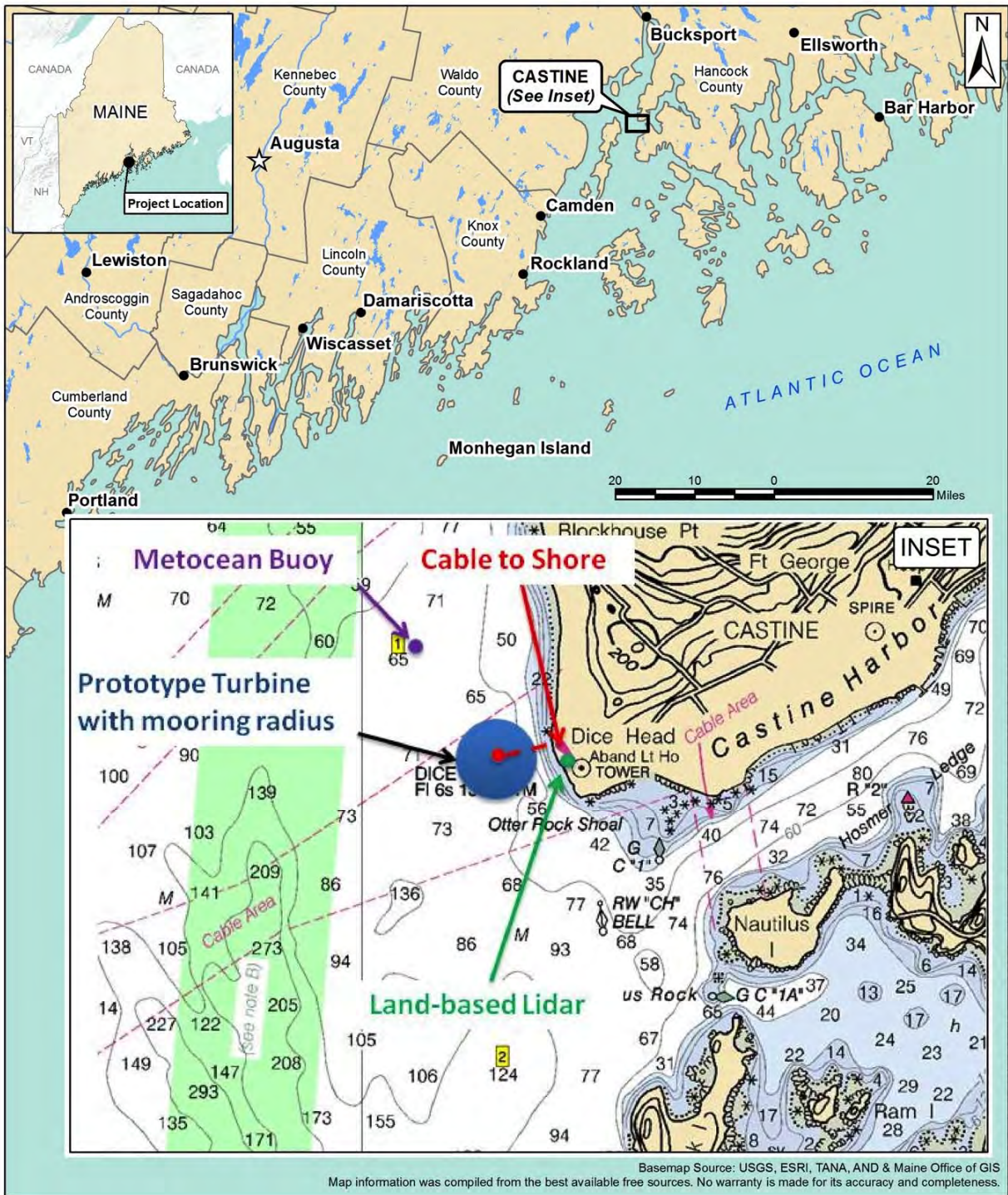


Figure 1-1. Proposed location of deployment of floating offshore wind turbine platform.

technological demonstration of those devices. UMaine is proposing to perform research on and development of a small-scale floating offshore wind turbine platform at Castine, Maine, as part of the DeepCwind Consortium Research Program. The primary objective of UMaine's testing a 1/8-scale floating wind turbine is to obtain motion and structural response data to compare and validate numerical models developed by NREL and others that predict structural loads, deflections, dynamics, and turbine power output under various meteorological and oceanographic conditions. Experimentally validated numerical models would aid in the development of floating platform technology for offshore wind energy. These models, once validated, would be used for design and optimization of floating turbines to help reduce the cost per installed kilowatt. Providing federal financial assistance to UMaine's proposed project would support the mission, vision, and goals of DOE's Wind and Water Power Program objectives to increase the development of reliable, affordable, and environmentally sustainable wind power technologies to realize the benefits of domestic renewable energy production.

## **1.4 Public and Agency Involvement**

### **1.4.1 UMAINE PUBLIC INVOLVEMENT**

UMaine selected the proposed project site following a comprehensive review of available information and meetings with the Castine-based Maine Maritime Academy (a research partner) and public meetings with the town of Castine. Maine Maritime Academy is leading public outreach efforts in the town of Castine, including meetings with town officials, coordinating with local stakeholder groups, and presenting at public town meetings. Maine Maritime Academy's President, Bill Brennan, made a presentation about the project at a February 22, 2012 meeting of the town's municipal officers. This meeting was open to the public and was attended by mostly year-round residents, the fishing community, and local press. President Brennan updated the town on project progress at subsequent town meetings, and Vice President Mercer of Maine Maritime Academy has been in regular communication about the project with town officials. Both Maine Maritime Academy and the town of Castine have been receptive to this project.

### **1.4.2 DOE AGENCY CONSULTATION AND PUBLIC INVOLVEMENT**

DOE has initiated consultation with the following federal agencies and Tribal organizations regarding the potential environmental impacts associated with the proposed project (Appendix A contains consultation letters):

- *Section 7 Endangered Species Act (ESA), Marine Mammal Protection Act, Magnuson-Stevens Fishery Conservation and Management Act*
  - DOE sent a request for information to the National Marine Fisheries Service (NMFS) on October 18, 2012.

- NMFS responded to DOE in a letter dated November 16, 2012. Information contained in this letter is discussed in Section 3.2.
- DOE sent a letter to NMFS on January 16, 2013 stating that the proposed project *may affect, but is not likely to adversely affect* ESA-listed fish, marine mammals, and sea turtles; the project would have minimal adverse effects on Essential Fish habitat (as regulated under the Magnuson-Stevens Fishery Conservation and Management Act); and that incidental take of species protected under the Marine Mammal Protection Act is unlikely to occur.
- NMFS concurred with DOE's conclusions in a letter dated February 20, 2013.
- Section 7 ESA
  - DOE sent a request for information to the U.S. Fish and Wildlife Service (USFWS) on October 18, 2012.
  - DOE sent a letter to USFWS on January 16, 2013 stating that the proposed project *may affect, but is not likely to adversely affect* the ESA-listed roseate tern and piping plover.
  - USFWS concurred with DOE's conclusions in a letter dated March 7, 2013.
- Section 106 National Historic Preservation Act
  - DOE sent a letter to the Maine State Historic Preservation Office (SHPO) on January 2, 2013.
  - DOE sent letters on November 2, 2012, to five Indian tribes or tribal organizations that may have historic ties to the Gulf of Maine.
  - SHPO stated in a letter dated January 2, 2013 that the project will have no adverse effect on historic properties as defined by Section 106 of the National Historic Preservation Act. The Penobscot Indian Nation and the Aroostook Band of Micmacs each responded to DOE in transmittals dated November 29, 2012. These responses are discussed in Section 3.5.

### 1.4.3 DRAFT SUPPLEMENTAL ENVIRONMENTAL ASSESSMENT

DOE issued the Draft Supplemental EA for comment on January 10, 2013, and posted it on the DOE Golden Field Office Reading Room Website ([http://www.eere.energy.gov/golden/Reading\\_Room.aspx](http://www.eere.energy.gov/golden/Reading_Room.aspx)) and DOE NEPA Website (<http://www.energy.gov/nepa>). DOE sent postcards to local stakeholders, government agencies, and tribal organizations to notify them of the availability of the Draft Supplemental EA and to announce a 15-day public comment period on contents of that document. A Notice of Availability was published in the *Bangor Daily News* and the *Castine Patriot* newspaper. DOE did not receive any comments on the Draft Supplemental EA.

## 2. PROPOSED ACTION AND ALTERNATIVES

### 2.1 DOE's Proposed Action

Under the Proposed Action, DOE would authorize UMaine to expend Congressionally Directed federal funding to temporarily deploy an offshore wind turbine test platform at the Castine site.

DOE has authorized UMaine to use a percentage of the federal funding for preliminary activities, which include preparing this Supplemental EA, conducting analyses, and agency consultations, and has approved similar deployment, testing, and retrieval activities at the Monhegan site. Such activities are associated with the Proposed Action and do not significantly impact the environment nor represent an irreversible or irretrievable commitment by DOE in advance of its conclusion of the potential environmental impacts from the proposed project.

### 2.2 University of Maine's Proposed Project

UMaine proposes to use DOE funding to deploy, test, and retrieve one approximately 1/8-scale wind turbine on a floating platform offshore of Castine, Maine, as part of its DeepCwind Consortium Research Program.

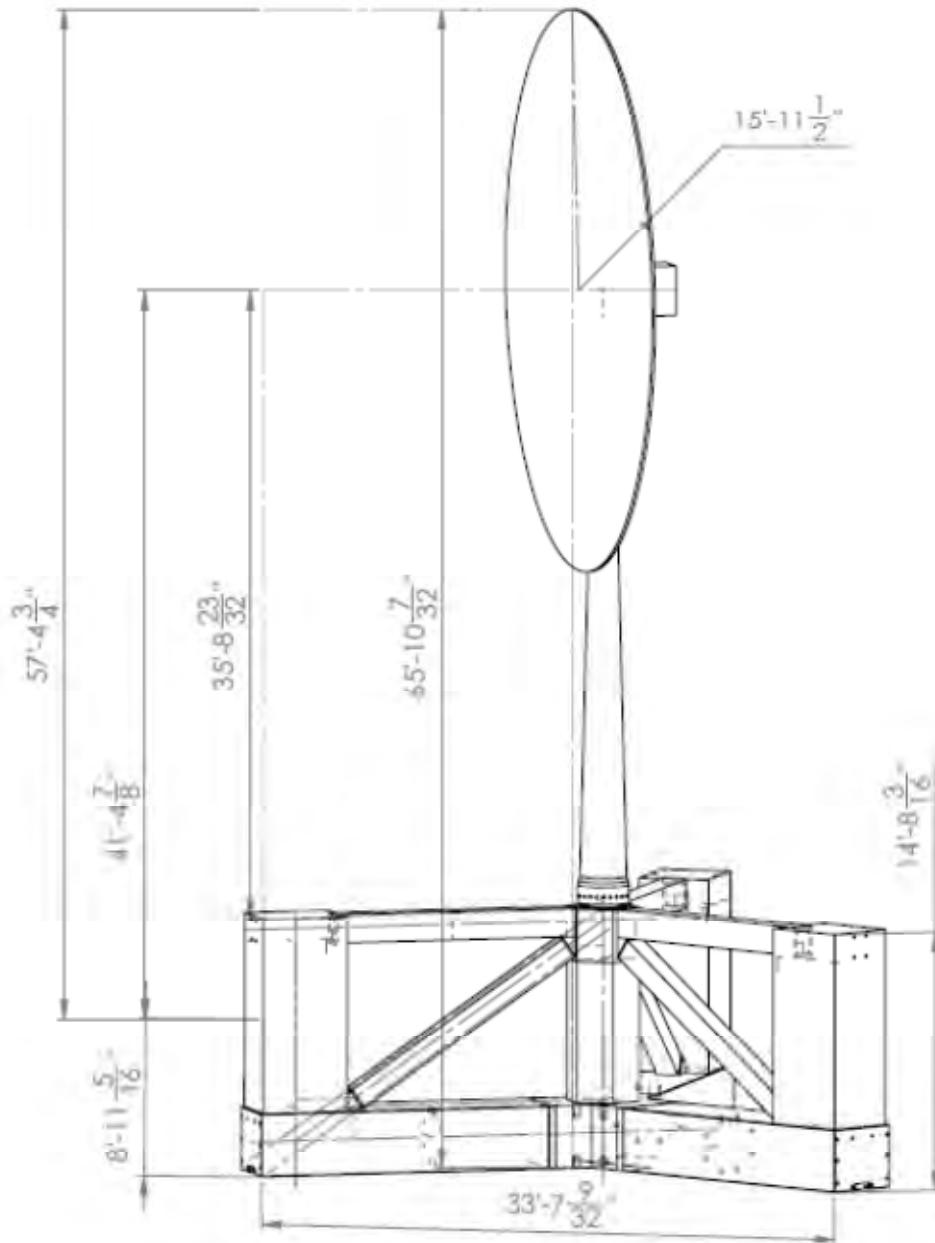
#### 2.2.1 OVERVIEW

UMaine proposes to use DOE funding to deploy and retrieve one 20-kW wind turbine on a floating platform offshore of Castine, Maine. Prior to deployment at the Monhegan site (the site evaluated in the original EA – see Section 1.3), UMaine proposes to conduct initial, temporary testing of the floating system at the Castine site in an existing cable right-of-way (ROW) within state waters (Figure 1-1). The system would be deployed for about four months in spring of 2013, offshore of Dyce Head at approximately N44° 23' 07", W 68° 49' 25". Water depth in the area is approximately 100 feet. The turbine would be connected to the Central Maine Power (CMP) grid via a cable to be installed along the seabed surface from below the turbine to shore, and along the ground to an existing CMP power pole.

During the site selection process, the following parameters were considered to evaluate potential sites: suitability of metocean (wind, wave, and current) conditions to achieve representative scale environmental conditions, proximity to marine infrastructure, historical metocean data, geophysical suitability, public support, and permitting. Castine was the only site that met all of the research programs needs. The sheltered harbor is desirable because the environmental conditions at this scale closely replicate full-scale conditions at the Monhegan site, and the design can be demonstrated at the smaller scale with the same desired effect.



The turbine would measure about 41 feet from waterline to the hub, the rotor diameter would measure about 32 feet, and the total turbine height would be about 57 feet (Figure 2-1). The final dimensions of the floating platform are currently under development as part of this research effort, but would not be any larger than what is shown below.



**Figure 2-1. Anticipated dimensions of the proposed floating offshore wind turbine to be deployed at Castine.**

The wind turbine system would be fabricated at UMaine, shipped to a coastal facility, and towed to and moored just outside of Castine Harbor in the proposed location. It would be tested in the

spring of 2013, and it would then be towed to the UMaine Deepwater Offshore Wind Test Site at Monhegan Island, Maine for part of the remainder of the year. Retrieval of the platform would occur following the deployment period. All anchors and the electrical cable would also be retrieved. Upon completion of that effort, the floating turbine platform would be towed back to the mainland, disassembled, and transported back to UMaine.

### **2.2.2 WIND TURBINE AND PLATFORM**

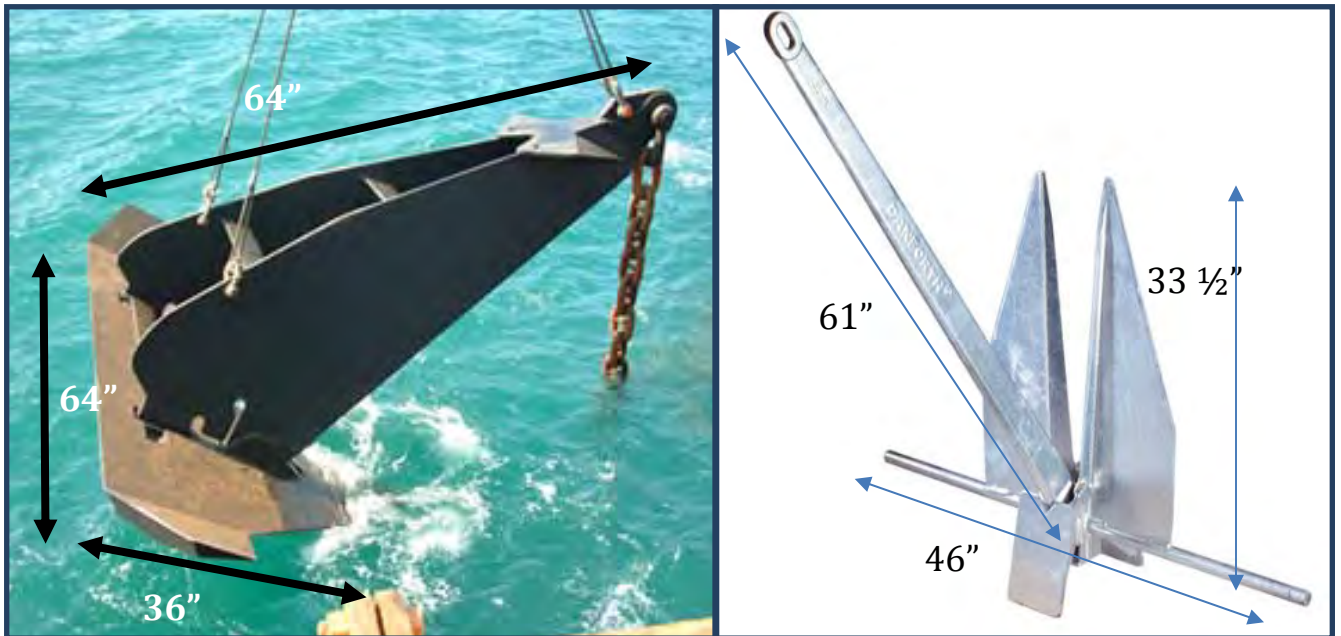
UMaine proposes to deploy one 20-kW Renewegy wind turbine within the project area on a floating platform. The turbine was selected based on the needs of the testing program, including the following: power control method (variable control pitching), lead-time for receiving the turbine, costs, suitability for use on this scale platform (mass, geometry, power output), structural capacity, and the availability of design information for numerical modeling. Several turbine options were considered, and the Renewegy model ranked the highest with regard to these needs.

The proposed wind turbine is a horizontal-axis generator with a power rating of 20 kW, or 27 horsepower. Although the onboard electronics, safety system, data acquisition system, and turbine operational controls would consume some power, the excess electrical power would be transferred to the Maine power grid via a 20-kW capacity cable to shore.

The proposed foundation is a semi-submersible tri-floater structure fabricated out of pre-stressed concrete. The approximate dimensions of the turbine and floating foundation are shown in Figure 2-1.

### **2.2.3 MOORING AND ANCHORING SYSTEM**

The mooring and anchoring system selected for the semi-submersible system is four drag embedment anchors with catenary mooring lines. The mooring lines would consist of synthetic/wire rope or chain, approximately 2-3 inches diameter. A number of shallow foundations/anchors were considered for mooring the project. A drag embedment anchor is preferred because it would minimize impact to the seafloor compared to other anchor designs, work with the bottom conditions at the proposed site, and would be easily removed at project completion. These anchors have dimensions similar to anchors used by large sailing vessels in Castine and along the Maine coast (Figure 2-2).

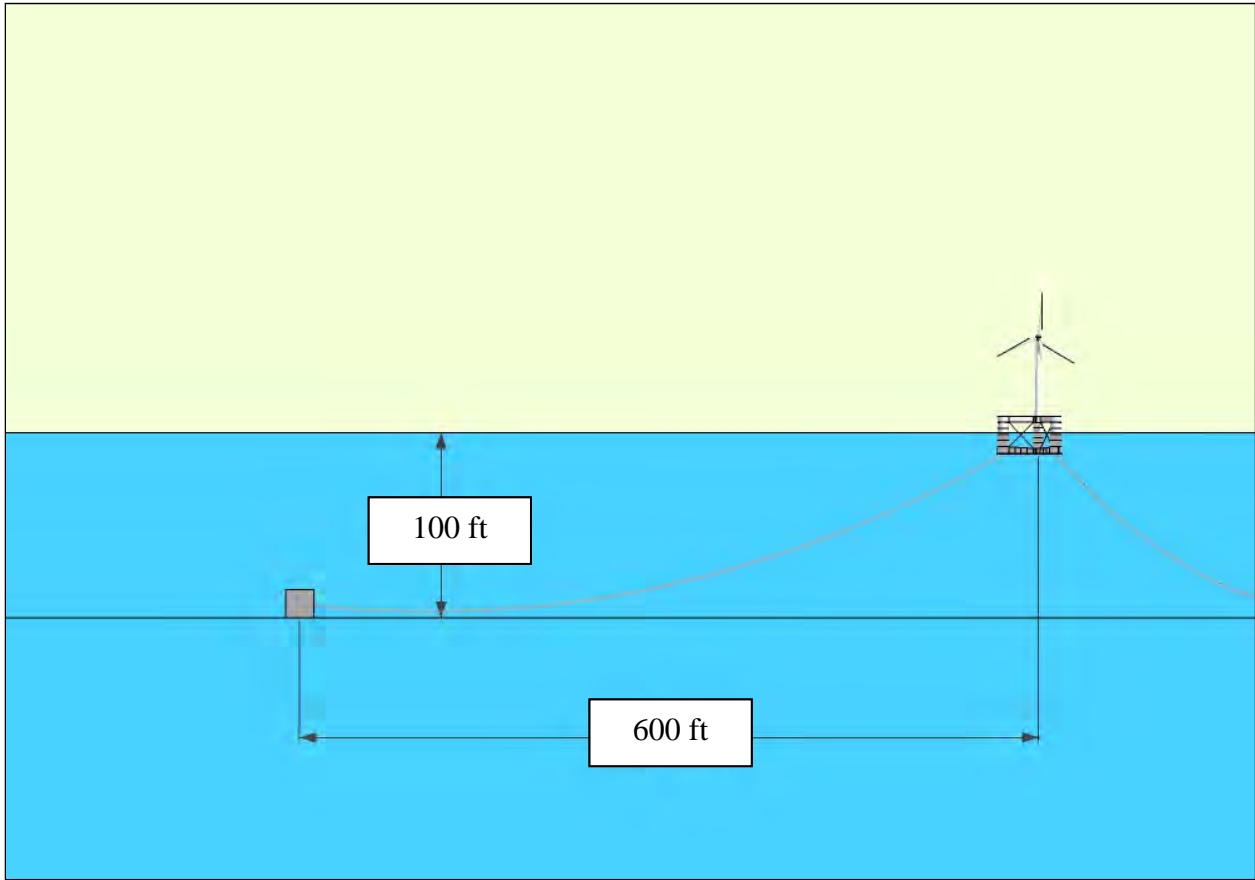


**Figure 2-2. Dimensions of proposed anchor for Castine floating turbine deployment (left) and typical boat anchor for vessels up to 83 feet long (right).**

Additional details of the anchors and mooring lines are shown in Table 2-1 and an elevation view drawing of the mooring lines is shown in Figure 2-3.

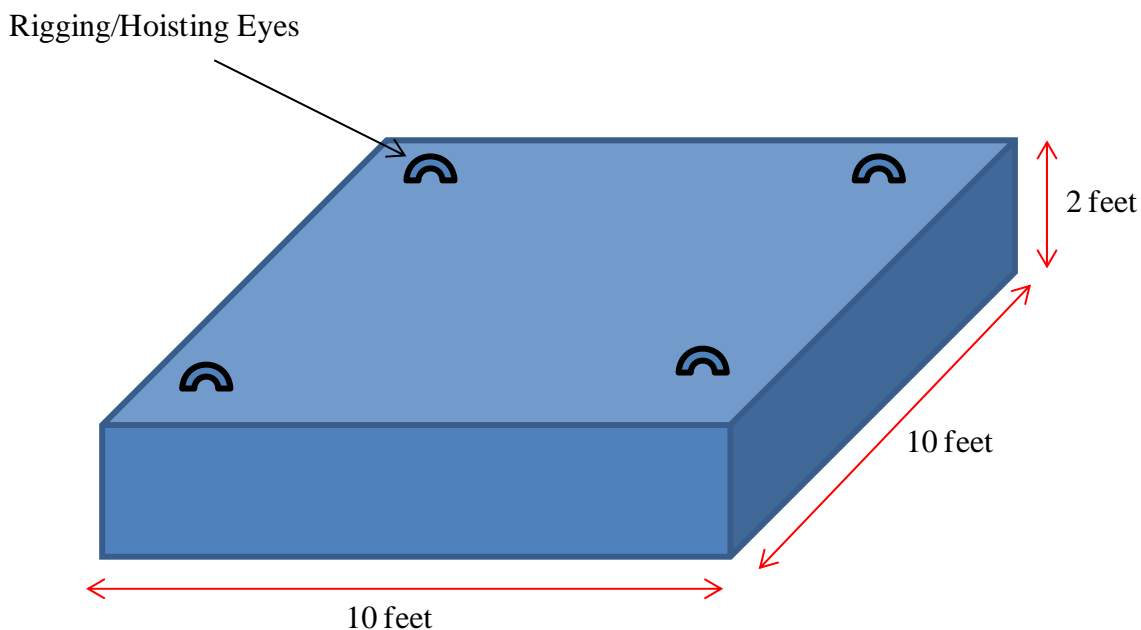
**Table 2-1. Mooring and anchoring dimensions and description.**

	Drag Embedment Anchor	Gravity Anchor
Mooring type and quantity	Catenary- 4 Lines	
Water Depth	100 ft	
Line length	Up to 1,000 ft	
Line material	Synthetic/wire rope or chain	
Anchor type and material	Steel drag embedment anchor	Concrete gravity anchor
Anchor weight	440 pounds	6,000 pounds
Anchor dimensions	36 inches x 64 inches	10 feet x 10 feet
Mooring radius (1:4 depth to horizontal radius)	Up to 600 ft	



**Figure 2-3. Elevation view of the proposed mooring line design (not to scale).**

In the event that the drag embedment anchors prove infeasible, UMaine would use gravity anchors. These anchors would be made of concrete, weigh approximately 6,000 pounds, and have dimensions of approximately 10 ft by 10 ft by 2 ft (Figure 2-4). Each anchor would have one catenary mooring line connected to the floating turbine platform, and the anchors would be removed at the end of the deployment.



**Figure 2-4. Alternative gravity anchor.**

## 2.2.4 ELECTRICAL INTERCONNECTION

Power would be generated at the turbine at 480-V, 3-phase, and would be delivered to the CMP grid through a combination of submarine and land based cables. The cables extending from the turbine to the point of interconnection on the shore would consist of three power cables, one per phase, one grounding conductor and one communications cable. The five cables would be contained in a single cable. The cable would run underwater for about 500 to 1,000 feet to shore. From just below the low tide line the cable would extend along the ground in a protective conduit to the point of interconnection at an existing CMP power pole. The terrestrial portion of the cable would be about 300 feet long.

## 2.2.5 INSTALLATION

The floating offshore wind turbine system would be constructed at UMaine's Advanced Structures and Composites Center and assembled at a shipyard or similar existing coastal facility, such as Cianbro's Modular Fabrication Facility in Brewer, Maine. The platform would be towed and moored within the Castine site for the testing period.

Each of the four anchors for the floating system would be installed by positioning the anchor on the sea floor and then tensioning the mooring line using a small tug boat. During the tensioning, the flukes would penetrate the seabed, and as tension increases, the anchor would be embedded. In the event that gravity anchors are used, they would just be placed on the seabed. Following

anchor deployment, small buoys would be installed to hold the mooring lines in place. After installation of the anchor and mooring system, the floating system would be towed from the launch site to the Castine test site. It is anticipated that it would take approximately two hours to tow the floating turbine from the launch site to the final destination at Castine. Notice would be given to the Maine Marine Patrol and USCG to alert fishermen about towing operations and to advise for the removal of gear from the planned tow route. When the floating system arrives on station, it would be connected to the pre-laid mooring system.

The floating platform and its anchorages would be installed using Maine Maritime Academy's unlimited tugboat *The Pentagoet*. This tugboat is 70 feet long and 24.5 feet at the beam, and weighs 99 gross tons. It is powered by a 1,200 horsepower design engine and is staffed by a crew of three. The vessel has onboard supplemental power systems and a lifting derrick, and routinely performs offshore installations similar to what is required for the pilot prototype unit. In the event that *The Pentagoet* is not available, a vessel with similar qualities and size would be used.

The onboard management of fuels and lubricating fluids aboard all vessels would be managed in accordance with U.S. Coast Guard regulations applicable to each vessel. The requirements are dictated by vessel size and intended operations, but in each case do not permit the discharge of petroleum or hazardous substances into the environment and require a spill prevention plan and certificate of financial responsibility.

Beginning at the offshore turbine mooring anchor, the electrical cable would run along the seabed approximately 500 to 1,000 feet to the shore, just below the low tide line. The cable would be anchored to the seafloor using simple weight strands every five feet; these would be removed with the cable at the project's conclusion. At that point the cable would be contained in a Schedule 40 rigid metal conduit within the tidal zone and Schedule 80 polyvinyl chloride (PVC) from the high tide location to the CMP point of interconnection in order to meet electrical code requirements.

The 2½-inch PVC conduit would extend approximately 300 feet from the high tide line to the point of interconnection near Dyce's Head Road. The conduit would be laid on the ground and anchored a minimum of every 10 feet along that route to meet code requirements. A single strap anchor would be mounted to concrete blocks at each anchoring location, one concrete block on either side of the conduit. The conduit would be placed and anchored by hand. In select locations where the concrete blocks would not provide a suitable and safe anchorage for the conduit, such as on steep slopes, hand held power tools would be used to drill holes and set anchors in rock. ATVs may be used to transport and handle materials, but no other heavy tools or vehicles would be operated on the site. Minimal hand cutting of limbs and brush would be conducted to facilitate routing and placement of the conduit. No trees would be removed and

select trimming would be focused on the centerline of the conduit with no trimming occurring beyond three feet on either side of the conduit. In areas of uneven terrain, the conduit might be supported with wooden blocks installed on the ground beneath the conduit to keep it level. The blocks would not require anchoring and would be removed along with the conduit at the end of the project. The blocks would be three feet or less in length.

The upland interconnection equipment, consisting of a transformer, a 3-phase to single-phase converter, and an electrical metering pack, would be installed temporarily on secure footings adjacent to the CMP interconnection point. Communications equipment also would be installed there for the data being collected for analysis of the project. Requirements for the CMP component of the installation are currently being finalized by UMaine. Requirements include completion of an interconnection application, which included specific electrical characteristics of the turbine. CMP has evaluated the proposed installation for electrical stability as a generator on the grid. Further, CMP's field planning teams met with UMaine's electrical engineering firm to determine the best routing of lines from power poles to the proposed termination point. A power terminal pole may be installed at the edge of the public way and the Town of Castine property to facilitate the connection to the grid. The entire footprint of the upland equipment would be approximately 10 feet by 12 feet.

Excess dust or debris that is deposited on the ground would be managed in manner to prevent off-site migration. Areas along the route that are disturbed to bare ground would be covered with straw mulch, and standard erosion control Best Management Practices would be implemented; for example, straw mulch would be placed along areas of the route that are disturbed to bare ground to minimize erosion.

The anticipated time required for project installation would be two days to deploy the four anchors, one day to install the turbine platform, two days to install the subsea cable, and two weeks for the land-side work.

## **2.2.6 OPERATIONS AND MAINTENANCE**

Following deployment of the platform, the focus of UMaine's proposed project would be testing the response of the turbine platform to various conditions of combined wind/wave loading. The turbine platform would carry sensor and telemetry systems that would provide data to evaluate the engineering, structural, and motion performance of the turbine platform under combined wind, wave, and environmental conditions. The comparison of the measured motions of a nearby metocean buoy (Figure 1-1) and the turbine platform would allow the response of the turbine platform to be evaluated relative to the oceanographic and meteorological conditions. The same conditions would then be simulated in the numerical models and compared as part of the model validation process.

While deployed, personnel access to the floating platform would be required for scheduled and unscheduled inspections, maintenance, and repairs. Access to this scale prototype would be via a standard size workboat from Maine Maritime Academy or other partner organization. The prototype would be equipped with a boat landing to facilitate personnel transfer and access means (e.g., Occupational Safety and Health Administration-compliant ladder) from the boat landing to the top deck. Maintenance and repair operations would require use of tools and equipment, and limited amounts of lubricants and hydraulic oils (30 ounces of brake fluid and one gallon of gear lubricant) would be within the turbine itself. For any unforeseen major repairs to the turbine or system, the platform is designed to easily re-attach to tug boats and be tugged back to port.

Environmental monitoring for birds (visual surveys and web camera observation), marine mammals (visual surveys), bats (echolocation detectors), and benthic invertebrates (remotely operated vehicle surveys and visual surveys) was initiated by UMaine in 2012 to support development of this Supplemental EA. In addition, ongoing monitoring results of fish in the project area, including acoustic detection of tagged fish and Maine Department of Marine Resources inshore fisheries surveys, were reviewed as well. These studies would continue in the area surrounding the test site during the deployment.

### **2.2.7 REMOVAL**

The floating offshore wind turbine system would be retrieved from Castine at the end of the deployment period in late June or early July 2013. It is possible that unanticipated removal of the turbine would be necessary in the case of an extreme weather event. Therefore, the design incorporates the capability to disconnect the floating turbine system from its moorings and tow it safely to port.

The removal of the floating turbine system and its associated moorings would be completed in two stages: 1) removal of the floating turbine system and 2) removal of the catenary moorings lines and anchors. For removal of the floating turbine, the same process would be used as for the deployment, but in reverse. The mooring line would then be towed in the opposite direction to remove the anchoring and mooring system.

All electrical interconnection equipment also would be removed. Upon completion of the project, the electrical cable anchors on shore would be removed and any bolts would be cut flush with existing grade, and support blocks and conduits would be removed. Disturbed areas would again be stabilized with straw mulch. Project removal activities would take a similar amount of time as the installation activities (see Section 2.2.7).



## 2.3 No Action Alternative

Under the No-Action Alternative, DOE would not authorize the expenditure of federal funds for the temporary deployment of the wind turbine test platform. As a result, installation of the project would be delayed while UMaine sought other funding sources, or abandoned if other funding sources could not be obtained. Furthermore, research towards reductions in fossil fuel use and improvements in energy efficiency would not occur through the activity of this project, and the DOE Wind and Water Power Program's mission and goals for offshore wind advancement would be impaired.

While it is possible that the wind turbine test platform could be constructed and operated in lieu of DOE financial assistance, such a scenario would not provide for a meaningful No Action Alternative, as it would be identical to the Proposed Project. Therefore, for the purposes of this EA, the No Action Alternative is evaluated as if the Proposed Project were not built and operated.

## 2.4 Required Agency Permits and Approval Types

Prior to installation of the turbine, DOE and UMaine will complete and comply with all required federal and state consultations, permits, and approvals (Table 2-2). The Maine Department of Environmental Protection issued the Permit by Rule on January 11, 2013. UMaine submitted a permit application to the U.S. Army Corps of Engineers on December 18, 2012.

**Table 2-2. Required permits and approvals.**

Agency	Permit/Approval
Maine Department of Environmental Protection	National Resources Protection Act, Section 9 Permit By Rule Notification
U.S. Army Corps of Engineers	River and Harbors Act, Section 10 Permit
National Oceanic and Atmospheric Administration (NOAA) NMFS, USFWS	ESA, Section 7 Consultation
NMFS and USFWS	Fish and Wildlife Coordination Act
NMFS	Marine Mammal Protection Act, Consultation
NMFS	Magnuson-Stevens Fishery Conservation and Management Act, EFH Consultation
U.S. Coast Guard	Ports and Waterways Safety Act, Consultation
Maine Department of Agriculture, Conservation, and Forestry – Maine Coastal Program	Coastal Zone Management Act, Section 307(c)(3) Consultation (part of DEP permit process)
Maine State Historic Preservation Office	National Historic Preservation Act, Section 106 Consultation

## 2.5 Applicant-Committed Measures

If DOE decides to provide federal funding for the proposed project the following measures will be implemented by UMaine to minimize or avoid potential environmental effects.

### 2.5.1 BIOLOGICAL RESOURCES

- To prevent seals from using the turbine platform for resting (seal haul out), the platform has been designed to limit the horizontal surfaces, and the platform deck height will preclude haul out of seals.
- The turbine tower will not have external ladders or other structures that will allow birds to perch near the turbine blades.
- The specifications for lighting of the floating platform and turbine will be developed in compliance with USFWS lighting requirements.
- UMaine will conduct monitoring for birds, bats, marine mammals, benthic invertebrates, and fish<sup>1</sup>. The monitoring will complement the pre-deployment monitoring that has already been performed. Results of the monitoring will be provided to DOE and applicable resources agencies.
- NMFS marine mammal avoidance and best management procedures will be implemented in the event that a marine mammal is encountered by a construction or maintenance vessel.
- The onboard management of fuels and lubricating fluids aboard all vessels will be managed in accordance with U.S. Coast Guard regulations applicable to each vessel. The requirements are dictated by vessel size and intended operations, but in each case do not permit the discharge of petroleum or hazardous substances into the environment and require a spill prevention plan and certificate of financial responsibility.

### 2.5.2 OCEAN AND LAND USE

- Notice will be given to the Maine Marine Patrol and USCG to alert fishermen about towing operations and to advise for the removal of gear from the planned tow route.
- Minimal hand cutting of limbs and brush will be conducted to facilitate routing and placement of the conduit. No trees will be removed and select trimming will be focused on the centerline of the conduit with no trimming occurring beyond three feet on either side of the conduit. Excess dust or debris that is deposited on the ground will be managed in manner to prevent off-site migration. Areas along the route that are disturbed

---

<sup>1</sup> NOAA and others have tagged fish with acoustic tags, which can in turn be detected by acoustic receivers, in the Gulf of Maine since 2005 to gather information on a variety of fish distribution and movements.

to bare ground will be covered with straw mulch, and standard erosion control Best Management Practices will be implemented.

- A navigation safety plan for the project has been developed in consultation with the USCG Waterways Management division.
- The turbine will be monitored via webcam and could be shut off remotely, if necessary.
- Following completion of the project, the floating turbine platform, anchors, and the electrical cable will be retrieved. The electrical cable anchors on shore will be removed, any bolts will be cut to flush with existing grade, and support blocks and the conduit will be removed. Disturbed areas will be stabilized with straw mulch.

### **2.5.3 CULTURAL RESOURCES**

- To minimize visual effects, the project will be sited out of view of the Village of Castine and in a previously disturbed cable ROW, and the project will be temporary and removed following completion of the testing.
- To minimize bottom effects, UMaine conducted a magnetometer survey and confirmed that there are no shipwrecks at the project site.

### 3.0 AFFECTED ENVIRONMENT AND ENVIRONMENTAL IMPACTS

#### 3.1 Environmental Categories Evaluated and Dismissed From Further Analysis

##### 3.1.1 GEOPHYSICAL RESOURCES

The only effect of the project upon marine geological resources would be from temporary placement of four anchors and cable, both within a previously disturbed cable ROW. No pile driving would occur, and no blasting would be required. The drag embedment anchor to be used would minimize impact to the seafloor compared to other anchor designs, works well with the bottom conditions at the proposed site, and is easily removed at project completion. The footprint of the anchors would be small, with the anchors having similar dimensions to (though heavier than) typical anchors used by large sailing vessels in Castine Harbor and along the Maine coast (Figure 2-2). During installation, drag embedment anchors would be pulled about 50 feet in order to set them with 10 feet of penetration. It is anticipated that half of this distance would be within the substrate below the seabed surface. The actual footprint of each anchor would be at most 16 ft<sup>2</sup>, with the four anchors therefore having a combined footprint of about 64 ft<sup>2</sup> and the footprint of the subsea cable and strip weights would be about 357 ft<sup>2</sup>. In the event that gravity anchors are used, each anchor would have a footprint of 100 ft<sup>2</sup> for a combined footprint of 400 ft<sup>2</sup>. The anchors and subsea cable would have a temporary effect on the thick sediment of the test area. The terrestrial portion of the cable would be laid on the ground and would not disturb geological resources.

##### 3.1.2 WATER RESOURCES

Due to the short duration of the deployment, there would be minimal accumulation of marine organisms (i.e., biofouling) on the floating turbine platform, and therefore, antifouling paint would not be applied. The onboard management of fuels and lubricating fluids aboard vessels would be managed in accordance with U.S. Coast Guard regulations applicable to each vessel. No intentional discharge of petroleum or hazardous substances would be allowed. Installation and operation of the project is not expected to influence dissolved oxygen concentration, pH, or temperature of the surrounding water. Deployment of the anchors and the cable to shore would result in a temporary and localized increase in turbidity during deployment, as would removal.

##### 3.1.3 ELECTROMAGNETIC FIELDS

Transmission of electricity produces electromagnetic fields (EMF). EMF consists of two components, electric and magnetic fields. Magnetic fields may create a second induced component, a weak electric field, called an induced electric field. An iE field is generated by the

flow of particles (water) or organisms through a magnetic field. Some marine animals (e.g. sharks, skates, and rays) have specialized organs and can sense EMF.

Operation of the project would result in a temporary, small, and very localized magnetic field. The Renewegy turbine has a capacity of 20 kW. Power would be generated at the turbine at 480-V, 3-phase, and would be delivered to shore through a submarine cable. The strength of electric and magnetic fields depends on the magnitude and type of current flowing, in this case, through the transmission cable. If the turbine is at full capacity, the current would be approximately 30 amperes. The shielding of the cable will eliminate electric fields, however, magnetic fields cannot be shielded. It is estimated that with the turbine generating at maximum power, the magnetic field would be 22 microtesla at 6 inches from the cable and 5 microtesla at 12 inches from the cable. In comparison, the strength of the earth's magnetic field is approximately 50 microtesla. The electrical set up for the project is less than what would be used for a normal residential service, which would have generally at least twice the current.

#### **3.1.4 AESTHETIC RESOURCES**

The floating platform would be deployed offshore and to the north of the Dyce Head. There is a lighthouse on Dyce Head, which is open to the public. The area surrounding the lighthouse has dense vegetation, including conifers and typical coastal undergrowth, which obscures any view of the ocean from the area around the lighthouse. In addition, the proposed deployment would not be visible from the end of the hiking path leading from the lighthouse to end of Dyce Head. The platform, which would be similar in size to large sail boats in the area, would be visible from a few homes to the north of the lighthouse.

The project deployment off Castine would be for only up to four months in the spring of 2013 and it would be removed before the period of the summer when peak boating and tourism/recreational activity occurs. Because the floating turbine platform is small (1/8 scale) and because it and the cable would be removed after the short-term deployment, any potential visual effects would be temporary.

#### **3.1.5 SOCIOECONOMICS AND ENVIRONMENTAL JUSTICE**

The small size of the floating turbine platform and short duration of deployment will minimize effects to lobstering, commercial fishing activities, tourism activities, or area businesses.

Executive Order 12898 (February 11, 1994) directs federal agencies to incorporate environmental justice considerations into the NEPA process. The purpose of this order is to ensure that low-income households, minority households, and minority businesses do not experience a disproportionate share of adverse environmental effects resulting from any given federal action. No potential adverse impacts to human health have been identified resulting from

the proposed project. Therefore, there would be no disproportionately high and adverse human health or environmental effects on minority populations and low-income populations.

### **3.1.6 INTENTIONAL DESTRUCTIVE ACTS**

Installation and operation of a floating wind turbine platform outside of Castine Harbor does not involve the transportation, storage, or use of radioactive, explosive, or toxic materials; therefore, it is unlikely that installation or operation of the project would be viewed as a potential target by saboteurs or terrorists. The project is not located near any national defense infrastructure or in the immediate vicinity of a major inland port, container terminal, freight trains, or other significant national structure. The project is not considered to offer any targets for intentional destructive acts.

## **3.2 Biological Resources**

This section analyzes potential project effects to the following biological resources, including threatened and endangered species:

- Invertebrates
- Fish
- Marine Mammals
- Reptiles
- Birds
- Bats
- Terrestrial Biological Resources.

### **3.2.1 AFFECTED ENVIRONMENT**

#### **3.2.1.1 Habitat Overview**

The proposed project's test site is located in Penobscot Bay, Maine. The site contains habitat used by benthic communities (species that live on or in the sea floor), demersal species (species that live and feed near the bottom), and pelagic species (species that live and feed away from the bottom).

The substrate at the test site is primarily fine grain sediment (i.e., mud). Muddy habitats typically have lower diversity and productivity than other marine habitats, though they are important in making plankton and detritus available to higher trophic levels (Gulf of Maine Council 2005). The nearshore subtidal habitat is marked by shell hash (shells of dead shellfish) and coarser grain sediment.

The intertidal area is dominated by rockweed (*Fucus vesiculosus*). The land rises very steeply from the intertidal zone, and terrestrial habitat is typical temperate coastal scrub, dominated by coniferous trees and shrubs. No wetlands are located at the site. Figure 3-1 shows views of the terrestrial vegetation in the area where the cable will be deployed. Terrestrial resources are further discussed further in Section 3.2.1.8.



**Figure 3-1. View of the property where the onshore cable would be deployed, looking toward shore (top) and inland (bottom).**

### 3.2.1.2 Invertebrates

Penobscot Bay supports a diverse variety of marine invertebrate species. A number of studies have characterized the invertebrate population in Penobscot Bay including those conducted by the Environmental Protection Agency (EPA 2007, benthic grabs for its Environmental Monitoring and Assessment Program [EMAP]), Maine-New Hampshire Inshore Trawl Surveys

(Sherman et al. 2010), and the Gulf of Maine Research Institute (angling and dive surveys, Sherwood et al. 2012). In addition to these sources of information, in 2012 UMaine conducted a diver survey along the cable route.

EPA's EMAP survey of eastern Penobscot Bay indicates that the benthic infauna is likely comprised, in order of highest count in samples, of Nephtyidae (catworms), *Haplocytheridea setipunctata* (an ostracod – a planktonic crustacean), *Aricidea suecica*, among other polychaete species (EPA 2007). The UMaine diver survey documented that sites very close to shore were dominated by sand dollars (*Echinarachnius parma*) and starfish (*Pisaster brevispinus*). However, 400 feet offshore the habitat transitions from coarse grain shell hash to fine muds; no species were observed other than sparse tube forming polychaetes (segmented worm) (Kennedy 2012).

Although no other conspicuous signs of macroinvertebrates were observed at the site by UMaine during diver surveys, trawl surveys conducted by the Maine Department of Marine Resources (DMR, the Maine-New Hampshire Inshore Trawl Surveys) indicate that the following invertebrates are relatively common elsewhere in Penobscot Bay: blue mussel (*Mytilus edulis*), sea scallop (*Placopecten magelanicus*), American oyster (*Crassostrea virginica*), Northern quahog (*Mercenaria mercenaria*), softshell clam (*Mya arenaria*), green sea urchin (*Strongylocentrotus droebachiensis*), daggerblade grass shrimp (*Palaemonetes pugio*), northern shrimp (*Pandalus borealis*), sevenspine bay shrimp (*Crangon septemspinosa*), American lobster (*Homarus americanus*), Jonah crab (*Cancer borealis*), Atlantic rock crab (*C. irroratus*), and green crab (*Carcinus maenas*) (Sherman et al. 2010) (Sherman et al. 2010). Atlantic rock crabs, green crabs, mussels, sea urchins, sea stars, and periwinkles (*Littorina littorea*) were the dominant macroinvertebrates documented in the project vicinity during angling and dive surveys conducted by researchers from the Gulf of Maine Research Institute (Sherwood et al. 2012). Lobsters are present in the area, as demonstrated by the presence of lobster buoys throughout the area offshore Castine (Kennedy 2012).

### 3.2.1.3 Fish

Penobscot Bay supports a diverse variety of finfish species. The Maine-New Hampshire Inshore Trawl Survey (Sherman et al. 2010) represents the best known source for fish species composition in the area. During a survey conducted during the time of the year that the project would be deployed, 34 fish species were captured in the sampling region that includes Penobscot Bay (Table 3-1) (Sherman et al. 2010). Many of the common marine species in Table 3-1 are uncommon as far up Penobscot Bay as Castine (e.g., redfish [*Sebastes fasciatus*], Atlantic cod [*Gadus morhua*], and haddock [*Melanogrammus aeglefinus*]), whereas some of the more estuarine species may regularly enter the test site (e.g., Atlantic herring [*Clupea harengus*], winter flounder [*Pseudopleuronectes americanus*], and windowpane flounder [*Scophthalmus*



*aquosus*]). This was demonstrated by the Gulf of Maine Research Institute during sampling in 2010, when sampling indicated that marine fish were relatively less common at the test site than at sites closer to the open ocean (Sherwood et al. 2012).

**Table 3-1. Summary of fish species most commonly captured in the Maine-New Hampshire Inshore Trawl Survey in or near Penobscot Bay, May 2010.**

Common Name	Scientific Name	Number Sampled
Atlantic herring	<i>Clupea harengus</i>	51
Alewife	<i>Alosa pseudoharengus</i>	47
Silver hake	<i>Merluccius bilinearis</i>	44
American plaice	<i>Hippoglossoides platessoides</i>	38
Winter flounder	<i>Pseudopleuronectes americanus</i>	34
Longhorn sculpin	<i>Myoxocephalus octodecemspinosus</i>	27
Windowpane flounder	<i>Scophthalmus aquosus</i>	25
Blueback herring	<i>Alosa aestivalis</i>	22
Red hake	<i>Urophycis chuss</i>	20
White hake	<i>Urophycis tenuis</i>	18
Witch flounder	<i>Glyptocephalus cynoglossus</i>	18
Rainbow Smelt	<i>Osmerus mordax</i>	16
Redfish	<i>Sebastes fasciatus</i>	13
Haddock	<i>Melanogrammus aeglefinus</i>	12
Pollock	<i>Pollachius virens</i>	9
American shad	<i>Alosa sapidissima</i>	8
Atlantic cod	<i>Gadus morhua</i>	7
Fourbeard rockling	<i>Enchelyopus cimbrius</i>	7

Less than 10 individuals of 20 other fish species also were captured, as were 20 shrimp (*Pandalus* sp.), a macroinvertebrate. Source: Sherman et al. 2010

Three fish species, all anadromous, listed under the ESA have the potential to occur in the project area:

- Atlantic salmon (*Salmo salar*) Gulf of Maine Distinct Population Segment are federally endangered;
- Shortnose sturgeon (*Acipenser brevirostrum*) are federally endangered; and
- Atlantic sturgeon (*A. oxyrinchus oxyrinchus*) are listed as federally threatened for the Gulf of Maine Distinct Population Segment (DPS) and federally endangered for the New York Bight DPS<sup>2</sup>.

<sup>2</sup> NMFS (2012) estimated that 1% of Atlantic sturgeon in the Penobscot River are New York Bight origin, based on a mixed stock analysis conducted in the Bay of Fundy, Canada that concluded that 1% of Atlantic sturgeon in the Bay of Fundy were New York Bight origin.

The project site is not located within designated critical habitat for the Atlantic salmon Gulf of Maine Distinct Population Segment, and no other critical habitat designated by NMFS occurs in Maine (letter from NMFS to DOE dated November 16, 2012). No state-listed fish species occur in the project area.

NOAA Fisheries, U.S. Geological Survey, and UMaine have been deploying and maintaining an array of acoustic receivers in the Penobscot River since 2005, as well as throughout the Gulf of Maine, to gather information on a variety of tagged fish distribution and movement. There is a detection buoy located near the test site, and it is part of an array of seven detection buoys that extends across eastern Penobscot Bay off of Dyce Head (Zydlewski 2012). Species they typically detect are Atlantic salmon (smolts), Atlantic sturgeon, spiny dogfish (*Squalus acanthias*), striped bass (*Morone saxatilis*), and shortnose sturgeon (Zydlewski et al 2011). Between 200 and 400 Atlantic salmon, 15 and 25 Atlantic sturgeon, and 25 and 40 shortnose sturgeon were tagged each of the last three years in the Penobscot River system and available for detection at the Dice Head array (Zydlewski 2012). This array would be in operation during the project deployment and would allow for monitoring of the presence of tagged species.

Under the Magnuson-Stevens Fishery Conservation Act of 1998 (16 U.S.C. 1801 et seq.; MSA) the waters of Penobscot Bay that include the project area have been designated as essential fish habitat (EFH) for 16 federally managed fish species (Table 3-2). EFH is broadly defined as “waters and substrate necessary to fish for spawning, breeding, feeding, or growth to maturity” (1996 Amendments (PL 104-267) to the MSA). EFH for the species listed in Table 3-2 varies by species and life stage, and includes all portions of the water column as well as substrate types, such as soft bottom, hard bottom, or various mixtures of hard and soft (NOAA 2012).

**Table 3-2. Marine species and life stages for which Essential Fish Habitat occurs in the portion of Penobscot Bay that includes Castine.**

Species	Eggs	Larvae	Juveniles	Adults
Atlantic salmon ( <i>Salmo salar</i> )			X	X
Atlantic cod ( <i>Gadus morhua</i> )		X	X	X
pollock ( <i>Pollachius virens</i> )			X	
whiting ( <i>Merluccius bilinearis</i> )			X	X
red hake ( <i>Urophycis chuss</i> )			X	X
white hake ( <i>Urophycis tenuis</i> )			X	X
winter flounder ( <i>Pseudopleuronectes americanus</i> )	X	X	X	X
yellowtail flounder ( <i>Limanda ferruginea</i> )	X	X		
windowpane flounder ( <i>Scophthalmus aquosus</i> )	X	X	X	X
American plaice ( <i>Hippoglossoides platessoides</i> )	X	X	X	X

Species	Eggs	Larvae	Juveniles	Adults
ocean pout ( <i>Macrozoarces americanus</i> )	X	X	X	X
Atlantic sea scallop ( <i>Placopecten magellanicus</i> )	X	X	X	X
Atlantic sea herring ( <i>Clupea harengus</i> )		X	X	X
bluefish ( <i>Pomatomus saltatrix</i> )			X	X
Atlantic mackerel ( <i>Scomber scombrus</i> )			X	X
bluefin tuna ( <i>Thunnus thynnus</i> )				X

Source: NOAA 2012.

In a letter to DOE dated November 16, 2012, NMFS stated that the waters in the vicinity of Castine support populations of diadromous species including blueback herring (*Alosa aestivalis*), alewife (*Alosa pseudoharengus*), rainbow smelt (*Osmerus mordax*), striped bass, American eel (*Anguilla rostrata*), and American shad (*Alosa sapidissima*). NMFS noted that diadromous fish serve as prey for a number of federally-managed species and several species are considered a component of EFH pursuant to the MSA.

#### 3.2.1.4 Marine Mammals

The Gulf of Maine is host to numerous marine mammals including large and small whale species, and three species of seals. Five ESA-listed whales that have the potential to occur in the Gulf of Maine are North Atlantic right (*Eubalaena glacialis*), fin (*Balaenoptera physalus*), humpback (*Megaptera novaeangliae*), sei (*B. borealis*), and sperm (*Physeter macrocephalus*) whales. None of these species were observed during the 17 boat-based visual surveys UMaine conducted from March through June 2012 in the project vicinity (Kennedy 2012). Right whales are present year-round in the Gulf of Maine, but sightings are uncommon in nearshore waters (Letter from NMFS to DOE dated November 16, 2012). Humpback whales are typically seen in waters off the coast, and fin, sei, and sperm whales are typically found in deeper offshore waters and are not likely to occur in the action area (Letter from NMFS to DOE dated November 16, 2012). The project is not located within any critical habitat of whale species (Letter from NMFS to DOE dated November 16, 2012).

During the 2012 boat-based visual surveys, UMaine observers counted 66 harbor seal (*Phoca vitulina*), one grey seal (*Halichoerus grypus*), and 34 harbor porpoise (*Phocoena phocoena*). Individuals of these three marine mammal species combined, were found at a density of 0.38 animals/km<sup>2</sup> (Kennedy 2012). In addition to these species, in a letter to DOE dated November 16, 2012, NMFS stated that minke whale (*B. acutorostrata*) Atlantic white-sided dolphin (*Lagernorhynchus acutus*), common dolphin (*Delphinus delphis*), short- and long-finned pilot whales (*Globicephala macrohynchus* and *G. melas*), and Kogia (pygmy sperm whale, *Kogia breviceps*) are also found in Maine coastal waters.

### 3.2.1.5 Reptiles

All sea turtles are protected under the ESA. Although sea turtle sightings are uncommon in the Gulf of Maine, leatherback (*Dermochelys coriacea*), loggerhead (*Caretta caretta*), and Atlantic Ridley (Kemp’s Ridley) (*Lepidochelys kempî*) sea turtles are known to occur there. The leatherback and Atlantic Ridley are endangered and the loggerhead is threatened under the ESA. The proposed project is not located within any critical habitat for marine turtles, and no turtles were observed during the boat-based visual surveys in the Castine Test Site vicinity over 17 weeks from March through June 2012 (Kennedy 2012).

### 3.2.1.6 Birds

Castine lies on the west side of the Blue Hill peninsula and on the northwest bank of the Bagaduce River, which is a 12-mile stretch of flowing tidal water that converges into Penobscot Bay. The BioDiversity Research Institute has created a Ranking of Bird Use map that categorizes areas from High to Low bird use. Near Castine and in the area surveyed in this report, bird use rates as “low” (BioDiversity Research Institute, 2012).

During UMaine’s 17 boat-based surveys from March through June of 2012, a total of 1,009 birds, representing 33 identified species, were recorded, with the three most abundant species being common eider (*Somateria mollissima*, 38%), herring gull (*Larus argentatus*, 20%), and common loon (*Gavia immer*, 9%) (Kennedy 2012). A list of the most common bird species observed is presented in Table 3-3.

**Table 3-3. Most common bird species observed offshore of Castine.**

Common name	Scientific name	Total number	No. of observations
Common eider	<i>Somateria mollissima</i>	379	28
Herring gull	<i>Larus argentatus</i>	206	154
Common loon	<i>Gavia immer</i>	95	75
Black guillemot	<i>Cepphus grylle</i>	57	48
Ring-billed gull	<i>Larus delawarensis</i>	41	29
Double-crested cormorant	<i>Phalacrocorax auritus</i>	39	26
Unidentified duck species		35	12
Red-throated loon*	<i>Gavia stellata</i>	18	13
American crow	<i>Corvus brachyrhynchos</i>	17	11
Turkey vulture	<i>Cathartes aura</i>	16	3
Red-breasted merganser	<i>Mergus serrator</i>	13	3

\*25 species other species were also observed in lesser numbers. Asterisk indicates Bird of Conservation Concern-species. Source: Kennedy 2012.

There are two ESA-listed birds that have the potential to occur in the project area, federally endangered roseate tern (*Sterna dougallii*) and federally threatened piping plover (*Charadrius melodus*). One unidentified tern (*Sterna* sp.) and no piping plovers were observed during the UMaine field surveys (Kennedy 2012).

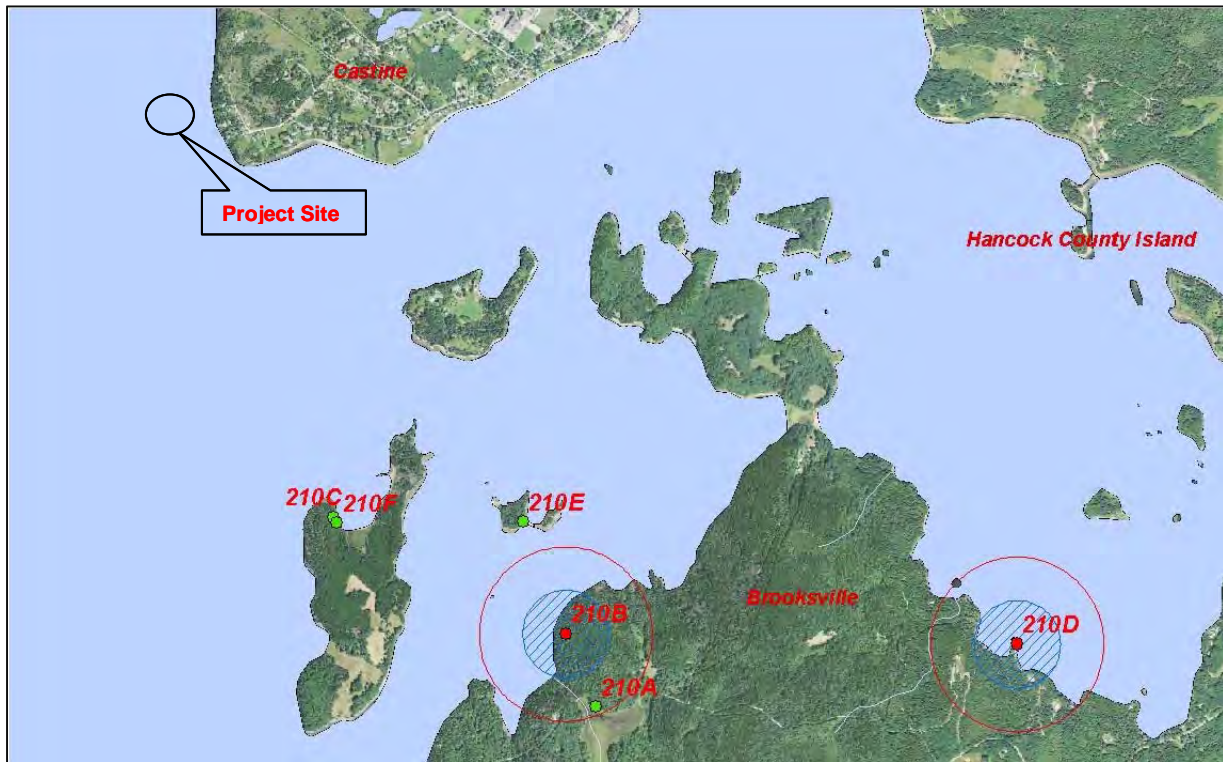
Bird species listed under the Maine ESA are listed in Table 3-4 and also include roseate tern and piping plover, which are both listed as state endangered. Regarding the unidentified tern that was documented during the UMaine survey, Maine lists two additional species of terns in the genus *Sterna*: least tern (*S. antillarum*), which is listed as state endangered and Arctic tern (*S. paradisaea*), which is listed as state threatened. Two other state listed bird species were observed during the UMaine field surveys: two razorbills (*Alca torda*, state threatened) and one peregrine falcon (*Falco peregrines*, state endangered) were seen (Kennedy 2012).

**Table 3-4. Bird species listed under the Maine Endangered Species Act.**

Common name	Scientific name
<b>Maine Endangered Species</b>	
American Pipit*	<i>Anthus rubescens</i>
Black Tern	<i>Chlidonias niger</i>
Golden Eagle	<i>Aquila chrysaetos</i>
Grasshopper Sparrow	<i>Ammodramus savannarum</i>
Least Bittern	<i>Lxobrychus exilis</i>
Least Tern	<i>Sterna antillarum</i>
Peregrine Falcon*	<i>Falco peregrinus</i>
Piping Plover	<i>Charadrius melodus</i>
Roseate Tern	<i>Sterna dougallii</i>
Sedge Wren	<i>Cistothorus platensis</i>
<b>Maine Threatened Species</b>	
Arctic Tern	<i>Sterna paradisaea</i>
Atlantic Puffin	<i>Fratercula arctica</i>
Barrow's Goldeneye	<i>Bucephala islandica</i>
Black-crowned Night Heron	<i>Nycticorax nycticorax</i>
Common Moorhen	<i>Gallinula chloropus</i>
Great Cormorant*	<i>Phalacrocorax carbo</i>
Harlequin Duck	<i>Histrionicus histrionicus</i>
Razorbill	<i>Alca torda</i>
Short-eared Owl*	<i>Asio flammeus</i>
Upland Sandpiper	<i>Bartramia longicauda</i>

\*Breeding population only  
Source: MDIFW 2012.

The USFWS created a list of species requiring special conservation action and awareness: the Birds of Conservation Concern 2008 (USFWS 2008). Species of Conservation Concern counted in the project area included 18 red-throated loons (*Gavia stellata*), three bald eagles (*Haliaeetus leucocephalus*), one peregrine falcon (*Falco peregrines*), two razorbills (*Alca torda*), and one unidentified tern. The most recent bald eagle nest sites close to the test site are approximately 2.5 miles south of the test site on Brooks Island (Figure 3-2).



Map courtesy of C.Todd (Maine Department of Inland Fisheries and Wildlife). Source: Kennedy 2012.

**Figure 3-2. Locations of most recent bald eagle nest sites in project vicinity (210B and 210D).**

### 3.2.1.7 Bats

Eight species of bats occur in Maine, based upon their normal geographical range. These are the little brown bat (*Myotis lucifugus*), northern long-eared bat, (*M. septentrionalis*), eastern small-footed bat (*M. leibii*), silver-haired bat (*Lasionycteris noctivagans*), tri-colored bat (*Perimyotis subflavus*), big brown bat (*Eptesicus fuscus*), eastern red bat (*Lasiurus borealis*), and hoary bat (*Lasiurus cinereus*) (DeGraaf and Yamasaki 2001). The red bat, hoary bat, and silver-haired bat are migratory in the region, while the other species seek hibernacula in natural and man-made structures, including buildings, tree cavities, caves, and rock crevasses (UMaine 2011). None of these species is listed under the ESA.

Bats become active in early spring after emerging from hibernation. To understand the composition of the bat assemblage during the later period of the deployment, surveys were conducted from the tower of the Dyce Head Lighthouse in Castine, the nearest feasible monitoring location to the site at which the test turbine is to be deployed. An acoustic detector was deployed on the tower of the Dyce Head Lighthouse on May 22, 2012, and operated nightly through July 10, 2012. A total of 797 bat call sequences were recorded during this period. Between 0 and 107 call sequences were recorded per night, with an overall activity level of 15.9 call sequences per detector-night. Bats were detected during 42 out of 50 surveyed nights (84 percent). Of the 797 recorded call sequences, 422 (53 percent) were identified to species or guild. Call fragments that were too short to be identified were classified as either high frequency or low frequency “unknown” (Stantec 2012). Results by species are as follows:

- 235 calls - big brown bat/silver-haired bat guild, including the big brown bat and silver-haired bat;
- 153 calls - *Myotis* genus;
- 19 calls - eastern red bats;
- 15 calls - hoary bats;
- 228 calls – high frequency unknown (likely includes eastern red bats, tri-colored bats, and *Myotis* species); and
- 147 call – low frequency unknown (likely includes big brown, silver-haired, and hoary bats) (Stantec 2012).

### 3.2.1.8 Terrestrial Biological Resources

The terrestrial portion of the project area from the tidal habitat to the point of electrical interconnection is typical temperate coastal scrub habitat dominated by coniferous trees and shrubs. Above the intertidal zone, the terrestrial habitat rises steeply, transitioning to a combination of trees (i.e., firs, spruces, larch, juniper, and birch were all noted at the site) and shrubs (primarily *Rosa rugosa*, staghorn sumac [*Rhus hirta*], and similar undergrowth common to coastal temperate Maine) (Figure 3-1). There are no hardwoods in the area, and it is therefore likely that this area is a transitional forest, not a mature forest. The cable would be laid along the ground for 300 feet and cross one residential property, for which landowner permission has been granted and an agreement is in place.

Common terrestrial fauna that could be expected to occur in the project area includes white tail deer (*Odocoileus virginianus*), raccoon (*Procyon lotor*), red squirrel (*Tamiasciurus hudsonicus*), striped skunk (*Mephitis mephitis*), long-tail weasel (*Mustela frenata*), bats (see Section 3.2.1.7), eastern garter snake (*Thamnophis sirtalis*), black capped chickadee (*Poecile atricapillus*), American crow (*Corvus brachyrhynchos*), and blue jay (*Cyanocitta cristata*).

### 3.2.2 ENVIRONMENTAL IMPACTS RELATED TO BIOLOGICAL RESOURCES

The marine components of the project may have the following potential effects on biological resources:

- Alteration of habitat;
  - direct effects on marine life from deployment on and removal from the seabed of the anchors and subsea cable and
  - changes to the marine community composition at the deployment site (e.g., use patterns, attraction, aversion);
- Above-water collision of birds and bats; and
- Underwater collision and entanglement – marine mammals.

In this section these potential effects on marine life, as well as potential effects on terrestrial biological resources, are evaluated as follows:

- Invertebrates
- Fish
- Marine Mammals
- Reptiles
- Birds
- Bats
- Terrestrial Biological Resources
- Threatened and Endangered Species.

The potential effects of noise are discussed in Section 3.3.

#### 3.2.2.1 Invertebrates

Some benthos would be disturbed during the deployment of the four anchors and the subsea cable on the seabed, and during their removal from the seabed. Specifically, the placement of anchors and the cable could cover or injure slow-moving or immobile benthic organisms, such as bivalves, sand dollars, and worms directly beneath the anchors and cable. Removal of the anchors and cable could also potentially harm slow-moving or immobile benthic organisms. UMaine plans to use drag embedment anchors because this anchor type minimizes impacts to the seafloor compared to other anchor designs, works with the bottom conditions at the proposed site, and is easily removed at project completion. During installation, drag embedment anchors would be pulled about 50 feet in order to set them with 10 feet of penetration. It is anticipated that half of this distance would be within the substrate below the seabed surface. This would cause disruption to the seabed, potentially killing slow-moving or immobile benthic organisms,



though any effect would be very minor considering the scale of and effect of commercial fishing bottom dragging operations. The actual footprint of project components resting on the seabed would consist of the four anchors (combined footprint of 64 ft<sup>2</sup> at most) and the subsea cable and strip weights (combined footprint of about 357 ft<sup>2</sup>). In the event that gravity anchors are used instead of drag embedment anchors, each anchor would have a footprint of 100 ft<sup>2</sup> for a combined footprint of 400 ft<sup>2</sup>. Mobile invertebrates would likely move away from the immediate vicinity of the project during deployment and removal activities. The area of the seabed that would be disturbed or covered by the anchors or subsea cable would be small for this 1/8-scale test turbine, and because the turbine would be deployed less than four months, any effects would be temporary.

### 3.2.2.2 Fish

Fish would likely move away from the immediate vicinity of the project during deployment and removal activities. It is anticipated that due to the small scale of the project and the short duration of deployment and removal activities there would be minimal disturbance to fish caused by deployment and removal of project components.

The presence of floating turbine platforms in the water column may result in altered use of the area by fish and a resulting change in the marine community composition in the following ways:

- Artificial reef effect<sup>3</sup> - The anchors, mooring lines, below-water portions of the turbine platform, and subsea cable could provide habitat for biofouling organisms and structure-oriented fish.
- Fish aggregation device (FAD) effect – Fish are also known to aggregate around floating objects (Nelson 2003), which is often called a FAD effect.
- Avoidance of the project area by resident and migratory species – For commercial-scale offshore wind projects, concerns have been raised that resident or migratory species might avoid wind farms.

These potential effects were discussed in detail in DOE's EA for the Monhegan Project (DOE 2011). The degree to which the project would affect use of the area by marine life would be minimized, and would not affect populations of species that use the area, because of:

- The small spatial scale of the project (revised to be even smaller – only one 1/8-scale platform, associated moorings, and a subsea cable deployed on the surface of the seabed);
- The deployment of the project in an existing subsea cable ROW;

---

<sup>3</sup> An artificial reef is a human-made underwater structure, typically built for the purpose of promoting marine life in areas of generally featureless bottom.

- The short duration of installation activities - the short period of time required for deployment and removal minimizes the potential avoidance of the area of marine species; and
- The short duration of the project - biofouling organisms would have only four months to grow before the platform would be removed, which minimizes the artificial reef effect of the platform.

As discussed in Section 3.2.1, there are a number of federally managed fish species with EFH in waters off of Castine (Table 3-2). Habitat types that represent EFH include all portions of the water column or substrate types, such as soft bottom, hard bottom, and various mixtures of hard and soft (NOAA 2012). The footprint of the anchors and cable might slightly decrease available bottom foraging habitat and areas considered to be EFH. However, the maximum area covered by the anchors (combined area of about 64 ft<sup>2</sup> for drag embedment anchors, 400 ft<sup>2</sup> if gravity anchors are used) and the 2½-inch subsea cable and associated strip weights (footprint of about 357 ft<sup>2</sup>) would be very small and the type of habitat to be disturbed is very prevalent along the Maine coast. Placement of anchors and the subsea cable in areas of soft bottom substrate would likely result in a temporary and localized increase in turbidity during deployment and removal; with only four anchors to be deployed, this effect would be small scale and short term. As discussed above, mobile species such as fish, would likely avoid the immediate deployment area during project installation activities. Project deployment activities for the marine components of the project are expected to total five days (two days to deploy the four anchors, one day to deploy the floating turbine platform, and two days to deploy the subsea cable). Project removal activities would take a similar amount of time. Therefore, any shift in habitat use by marine or diadromous species during installation or removal activities would be small scale and temporary.

### 3.2.2.3 Marine Mammals

During surveys in the project vicinity, 66 harbor seals, one gray seal, and 34 harbor porpoise were observed. No large whales were observed (Kennedy 2012). Harbor seals, gray seals, and harbor porpoise would likely avoid the immediate vicinity of the project during deployment and removal activities. A slight increase in vessel traffic associated with the project installation and maintenance would be negligible for this small scale and temporary project. While the potential for a vessel and marine mammal interaction is unlikely, NMFS marine mammal avoidance procedures, in compliance with the Marine Mammal Protection Act, would be implemented in the event that a marine mammal is encountered by a service vessel. The small scale of the project and the short duration of deployment and removal activities are expected to minimize any disturbance to marine mammals caused by deployment and removal of the project.

The presence of floating turbine platforms in the water column and floating above the water may result in temporary altered use by marine life. For example, seals are known to haul out on

nearly any accessible floating platform. UMaine is implementing design measures to prevent seal haul out (the platform deck will be raised several feet above the water level). As discussed in the previous section, because of the small size and temporary nature of the project, it is not expected that it would change the habitat or the marine community in the deployment area in other ways (e.g. artificial reef effect, FAD effect, avoidance of the project area by resident and migratory species).

The remainder of this section evaluates the potential that marine mammals may become entangled, or collide, with the project mooring lines. Marine mammals in the Gulf of Maine are exposed to a variety of anthropogenic structures in the water column, including moored navigation aids and oceanographic buoys, anchored and moving ships, and lobster buoys. Moored vessels are common in harbors, such as Castine Harbor, and other locations along the Maine coast. During the UMaine biological surveys, researchers documented densities of lobster buoys as high as 9.9 buoys/km<sup>2</sup> in the project vicinity (Kennedy 2012).

Marine mammals have evolved to avoid colliding with natural features as well as to avoid predators. For example, many toothed whales have a well-developed ability to echolocate and avoid structures in the water (Akamatsu et al. 2005). In a study of finless porpoise (*Neophocaena phocaenoides*), Akamatsu et al. (2005) found that this species inspected ahead a distance of up to 250 feet and swam less than 65 feet without using sonar. Researchers concluded that the distance inspected was sufficient to provide awareness of any risk ahead (Akamatsu et al. 2005). Seals have well-adapted underwater vision (Schusterman and Balliet 1970) and use their vibrissae to detect changes in pressure or vibrations in the water (Dehnhardt et al. 2001; Mills and Renouf 1986). Because of the acute sensory capabilities of toothed whales (echolocation) and the small size and maneuverability of seals, it is expected that the marine mammal species that occur in the project area would be able to detect and avoid underwater moorings.

There is generally more uncertainty regarding the ability of baleen whales, which do not use sonar, to avoid mooring lines. However, whale collisions with moored ships and buoys are uncommon. Also, large whales are not expected to occur in the project area, which is located in upper Penobscot Bay relatively close to shore.

In addition, the mass/buoyancy of the platform and mass of the anchors is expected to create substantial tension in the mooring lines. These factors would prevent the formation of loops around a passing whale. The potential for heavy mooring gear combined with relatively taut mooring lines to entangle whales has been shown to be negligible (Wursig and Gaily 2002).

In the event that the turbine is removed from the moorings for some reason (e.g., severe weather), the synthetic/wire rope or chain mooring lines would be connected to a light mooring

rope and dropped to the bottom of the seafloor. The mooring rope would be connected to a floating mooring ball so that the steel portions of the mooring line can be later retrieved and re-connected to the platform. With the synthetic/wire rope or chain on the seafloor, the mooring lines would not be an entanglement hazard. The light mooring ropes would be similar to lobster pot lines which are very common in the area and along the Maine coast.

In addition, it is unlikely that large whales would encounter the project because of the small size of the project relative to surrounding open ocean area of Penobscot Bay, the fact that the platform would be temporarily deployed for up to only four months, and that large whale presence at the project area is unlikely.

#### 3.2.2.4 Reptiles

Potential effects to the three sea turtle species that may occur off of Maine, which are listed under the ESA, are discussed in Section 3.2.2.8.

#### 3.2.2.5 Birds

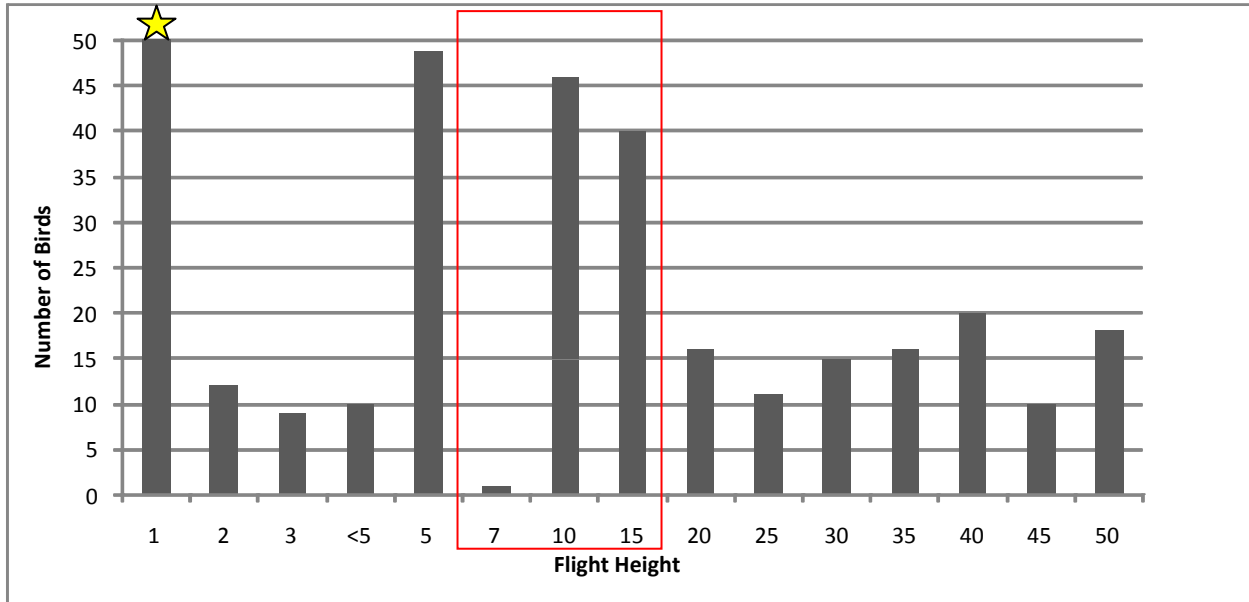
The presence of a turbine platform floating above the water may result in temporary altered use of the area for seabirds by providing a place to roost. UMaine would implement measures to minimize bird attraction and roosting. For example, the turbine would not have external ladders or other structures that would allow birds to perch near the turbine blades.

The operation of the proposed project would introduce static and moving above-water components at the site, potentially within the flyway of birds. During project operation, migrating and foraging birds could be at risk of colliding with the turbine. As described below, the probability of birds being killed or injured by the 1/8-scale turbine is low.

While varying with location, the national average of collision-related mortality for birds at land-based commercial wind farms is less than three birds per commercial-scale turbine (i.e., larger than about 1 megawatt) per year (Erickson et al. 2001). The Castine turbine would be lit at night with a flashing sequence for the purposes of navigational safety. Some bird species such as petrels and migrating songbirds can be attracted to light during nighttime and diurnal conditions with poor visibility (UMaine 2011), which could put such species at a higher risk of collision with the turbine.

The proposed turbine would have a rotor sweep zone ranging from approximately 25 feet to 57 feet above the water surface (actual rotor diameter of 31.5 feet). Of the 456 flying birds observed during the 17 surveys UMaine conducted between March through the end of June 2012, the majority flew at or under 16.4 feet (5 meters) and 40% flew at 3.2 feet (1 meter) high.

Approximately 19% flew between heights of the rotor sweep zone (Figure 3-3). Herring gulls, ring-billed gulls (*Larus delawarensis*), and common loons were the most common species to be flying in the height range of the rotor (Kennedy 2012).



The yellow star represents a total of 183 birds at one meter high. The red box shows the approximate height range of the turbine rotor. Source: Kennedy 2012.

**Figure 3-3. Flight heights for bird species observed during UMaine 2012 visual surveys.**

Some birds might collide with the turbine and be killed or injured during the four-month deployment. However, the rotor swept area would be 779 feet<sup>2</sup>, which is much smaller than the 1/3 scale turbines evaluated at the Monhegan site, which had a rotor swept area of 6,165 feet<sup>2</sup>, almost 8 times larger. The relatively small rotor diameter of the Castine 1/8-scale turbine, and the temporary nature of the deployment, would minimize collision risk for birds. During the period of deployment, boat based visual surveys of birds would be performed on site weekly and a web camera would be deployed on the unit to monitor bird strikes. Visual observation methods will replicate the pre-deployment monitoring.

### 3.2.2.6 Bats

As with birds, the operation of the proposed project would introduce static and moving above-water components at the site, potentially within the flyway of bats. During project operation, bats could be at risk of colliding with the turbine. As described below, the probability of bats being killed or injured by the 1/8-scale turbine is low.

Bat fatalities at wind energy facilities appear to be highest along forested ridgetops in the eastern U.S. and lowest in relatively open landscapes in the midwestern and western states (Kunz et al. 2007). A consistent theme in most of the mortality monitoring studies conducted at utility-scale wind farms has been the predominance of migratory, tree-roosting species among the fatalities. Of them, nearly 75 percent were tree-roosting, eastern red bats, hoary bats, and tree cavity-dwelling silver-haired bats (Kunz et al. 2007).

The results of the bat surveys conducted during the summer of 2012, demonstrated that bats are present at the Dyce Head Lighthouse, and it is expected that these bats may occasionally fly over the water or cross the mouth of the Penobscot River to forage at nearby islands or to access land on the opposite side of the bay (Stantec 2012). The surveys could not identify the height at which the bats were flying (Stantec 2012), and it is expected that bats thus flying over the water could be exposed to the turbine.

Some bats might collide with the turbine and be killed or injured during the four-month deployment. However, the relatively small rotor diameter of the Castine 1/8-scale turbine, and the temporary nature of the deployment, would minimize collision risk for bats. In addition, because the proposed project is not located near a forested ridgeline and is instead located about 500 to 1,000 feet from the shore in open water, the probability of bat fatalities at the test site is very low.

#### 3.2.2.7 Terrestrial Biological Resources

For the terrestrial portion of the project, the cable, contained in a conduit, would be laid on and anchored to the ground for up 300 feet from the high tide line to the interconnect point. Some trimming of vegetation might be needed along the centerline of the conduit path, but no trimming would occur beyond three feet of that path. Deployment of the terrestrial portion of the project is expected to take two weeks. Following the approximately four-month (or less) deployment of the floating turbine platform, the cable would be removed. Because of the very small footprint of the shore component of the project, the design of the project so as to minimize terrestrial disturbance, and the short duration and subsequent removal of the project, the project effects to the terrestrial environment would be minimal and temporary.

#### 3.2.2.8 Threatened and Endangered Species

For the larger floating wind turbine platforms proposed for deployment at the Monhegan test site and evaluated in the September 2011 DOE EA, NMFS in a letter dated February 22, 2011, concurred with DOE that the project may affect, but would not likely adversely affect ESA-listed fish, marine mammals, and sea turtles or EFH under the Magnuson-Stevens Fishery Conservation and Management Act. NMFS also concurred that impacts to protected marine

mammals are unlikely to occur. In a letter dated August 18, 2011, USFWS concurred with DOE that the project effects are likely to be insignificant and discountable and would not likely adversely affect the ESA-listed roseate tern and piping plover (DOE 2011). As described below, the effects of temporarily deploying a single 1/8-scale platform and turbine at the Castine site would have similar or less effects than those identified for testing at the Monhegan site.

Three ESA-listed fish species, Atlantic salmon, shortnose sturgeon, and Atlantic sturgeon, have the potential to occur in the project area. All three species were detected at the Dice Head acoustic detection array during monitoring from 2009 to 2011. Movements through the array were seasonal with Atlantic salmon movements focused in May, Atlantic sturgeon movements throughout the year but focused in May and October, and shortnose sturgeon movements occurring from May to July (Zydlewski 2012). These three species use the project area as a migration corridor. This part of Penobscot Bay is very expansive and quite deep, and the project would not obstruct these species as they swim into and out of the Penobscot River and estuary. The small size of this research project relative to the surrounding marine habitat, the short nature of the deployment, the limited time these migratory fishes would be in the project site, and the overall lack of potential mechanism for effect to fish, all minimize the risk of effect to these three species.

Five ESA-listed whales that have the potential to occur in waters offshore of Maine are North Atlantic right, fin, humpback, sei, and sperm whales. None of these species were observed during the 17 boat-based visual surveys (Kennedy 2012), nor are they expected to occur near shore in the upper Penobscot Bay where the project is located. The likelihood of exposure of ESA-listed whales to the proposed project is extremely small, given that ESA-listed whales are uncommon in the project area, the small size of the project relative to the surrounding Penobscot Bay, and the fact that the platform would be temporarily deployed for up to only four months. In addition, the mass/buoyancy of the platform and mass of the anchors is expected to create substantial tension in the mooring lines, which would prevent the formation of loops around a passing animal. In the event that the turbine is removed from the moorings for some reason (e.g., severe weather), the synthetic/wire rope or chain mooring lines would be connected to a light mooring rope and dropped to the bottom of the seafloor. The mooring rope would be connected to a floating mooring ball so that the steel portions of the mooring line can be later retrieved and re-connected to the platform. With the synthetic/wire rope or chain on the seafloor, the mooring lines would not be an entanglement hazard. The light mooring ropes would be similar to lobster pot lines which are very common in the area and along the Maine coast.

There are three ESA-listed sea turtles with the potential to occur in the Gulf of Maine: Atlantic Ridley, loggerhead, and leatherback sea turtles. Sea turtle sightings in the Gulf of Maine are rare, and these species are very unlikely to occur near shore in upper Penobscot Bay where the project is located. The likelihood of exposure of sea turtles to the proposed project is extremely

small given that sea turtles are uncommon in the project area, the small size of the project relative to the surrounding Penobscot Bay, and the fact that the platform would be temporarily deployed for up to only four months. Also, the substantial tension in the mooring lines would prevent the formation of loops that could entangle a passing animal. No other potential effects on sea turtles are anticipated.

There are two ESA-listed birds and a number of state-listed birds that have the potential to occur in the project area. Of these, only one unidentified tern (*Sterna* sp.), two razorbills, and one peregrine falcon were observed during the UMaine field surveys (Kennedy 2012)<sup>4</sup>. Because the proposed project would be small scale and have a short operational duration, there is a minimal likelihood that listed species would be harmed by the turbine rotor.

### 3.2.3 NO-ACTION ALTERNATIVE

Under the No-Action Alternative, DOE would not fund the proposed project, installation and operation of the 1/8-scale floating wind turbine would not occur, and there would be no impacts to biological resources. Baseline conditions, as described in Section 3.2.1, would remain unchanged.

## 3.3 Noise and Vibration

### 3.3.1 AFFECTED ENVIRONMENT

Existing noise levels in the project area are expected to be typical of a near-shore/estuarine setting having relatively high boat traffic because of its proximity to Castine Harbor. In the marine/estuarine environment, a variety of natural and anthropogenic sources create ambient noise, both intermittent and continuous. Sources of ambient noise include waves, wind, bubbles and spray, marine life, seismic events, commercial and recreational vessel traffic, and thermal noise from random agitation of water molecules (Bradley and Stern 2008; Richardson et al. 1995). Ambient noise pressure spectral densities can range from about 35 to 80 decibels (referenced to one micropascal squared per hertz [re 1  $\mu\text{Pa}^2/\text{Hz}$ ]) for usual marine traffic (10 to 1,000 hertz), and 20 to 80 decibels (re 1  $\mu\text{Pa}^2/\text{Hz}$ ) for breaking waves and associated spray and bubbles (100 to 25,000 hertz; Richardson et al. 1995).

During the boat-based visual survey at the Castine project site, observation of boat traffic occurred during 17 surveys from April to June 2012. A total of 13 boats were observed while

---

<sup>4</sup> Roseate tern is federally and state endangered, least tern is state endangered, and Arctic tern is state threatened. Razorbill is state threatened and peregrine falcon is state endangered.



surveys were performed. Six of the boats were various types of sailing vessels, four were assorted private motorized boats, and the remaining three were fishing vessels for lobster or fish.

The Port of Searsport is located northwest, across Penobscot Bay from Castine, and the Penobscot River ports of Bucksport and Bangor are located north of Castine, up the Penobscot River. NOAA navigation charts identify two Recommended Vessel Routes that run the length of Penobscot Bay, and the edge of the nearest route is located approximately 3,000 feet west of the proposed deployment location.

In the open ocean setting, the primary noise sources tend to be commercial shipping and wind and wave action on the sea surface (Richardson et al. 1995). Noise sources are expected to be similar at the project site, though upper Penobscot Bay, being more sheltered than the open ocean, would not have as much wind and wave action compared to the open ocean. Anthropogenic sources of noise in the project area would include fishing and recreational boats originating from Castine Harbor and elsewhere, as well as periodic traffic of larger ships and barges associated with the ports to the north of Castine.

### **3.3.2 ENVIRONMENTAL IMPACTS RELATED TO NOISE AND VIBRATION**

The installation, operation, and removal of the floating wind turbine and subsea cable would result in a temporary increase in underwater noise created from service vessels and equipment, similar to vessels commonly used throughout the coast, and may temporarily cause marine life to avoid the project area. The Renewegy 20 kW turbine creates noise levels of about 50 dB at 120 feet (Renewegy 2012). For comparison, a 2-person conversation is about 47 dB (Bradley and Stearn 2008). At 500 to 1,000 feet, noise from operation of the wind turbine would decrease to a level that would likely not be detectable or would be barely audible to people on shore, close to the project (i.e. Dyce Head). In addition, during windy periods, turbine noise would be dampened by ambient noise (e.g., wind and waves) and during calm periods, the turbine would spin less or not at all, resulting in less or no noise.

The predominant source of noise during project installation, maintenance, and removal would be the service vessels' propellers (MMS 2007). As discussed in Section 2.2.7, the pilot prototype unit and its anchorages would be installed using Maine Maritime Academy's unlimited tugboat *The Pentagoet*, or a similar vessel. *The Pentagoet* is 70 feet long and is powered by a 1,200 HP design engine. It is expected that the peak underwater sound intensity, generated by a tug fully underway, would be no greater than 130 to 160 decibels (re 1  $\mu$ Pa) over a frequency range of 20 hertz to 10 kilohertz (Richardson et al. 1995). The tug or smaller research vessels should be fully underway only when traveling to and from the test site. It is expected that most of the time during project activities the sound intensity would be much lower.

During project installation, maintenance, and removal, it is expected that the above-water sounds from the support vessels and equipment would not be transmitted into the water at a higher level than natural environmental noise from wind and wave action. The Federal Regulatory Commission, in its environmental assessment for the Makah Bay Wave Energy Project in Washington, concluded that above-water sounds from support vessels and equipment would be largely damped by ambient ocean noise on all but the calmest of days (FERC 2007).

UMaine expects installation of the marine components of the project would take a total of about five days (two days to deploy the four anchors, one day to deploy the turbine platform, and two days to install the subsea cable). Project removal activities would take a similar amount of time. Underwater noise associated with the installation, maintenance, and removal activities might cause some fish, marine mammals, birds, and other marine life to avoid the project area; however, this would be short term, with behavior returning to normal after the service vessels leave the site.

Noise created during project operation would be from the mechanical motion of the internal turbine components as well as the aerodynamic interaction of the rotor blades with the surrounding air. Sound levels underwater resulting from turbine noise transferred through the sea surface are expected to be substantially lower than the sound source levels, due to the reflective nature of the sea surface (Jones et al. 2010). Acoustic emissions underwater, due to vibrations of the turbine and platform structure, are expected to be low frequency and low amplitude, and are strongly dependent on turbine and platform configuration and dynamic loads (Jones et al. 2010). Because of the low level of noise created by a Renewegy 20 kW turbine, the temporary nature of the deployment, and because only a small amount of sound can transfer through the sea surface from above, underwater noise levels resulting from turbine operation are expected to be very low.

### **Threatened and Endangered Species**

Noise associated with project installation, maintenance, and removal activities might cause threatened and endangered fish, whales, birds, and sea turtles to avoid project service vessels, as they might avoid any vessels commonly used along the coast. Any avoidance of service vessels associated with the temporary project would be infrequent and short term with behavior returning to normal after the service vessels leave the site. Effects of project noise would be minimized because of the small scale and temporary nature of the turbine, the low likelihood that listed species would be exposed to the project, the low level of turbine noise to begin with, and because only a small amount of sound is expected to result from transfer of above-water sound through the sea surface.

### **3.3.3 NO-ACTION ALTERNATIVE**

Under the No-Action Alternative, DOE would not fund the proposed project, installation and operation of the 1/8-scale floating wind turbine would not occur, and there would be no change in noise conditions in the project area. Baseline conditions, as described in Section 3.2.1, would remain the same.

## **3.4 Ocean and Land Use**

### **3.4.1 AFFECTED ENVIRONMENT**

#### **3.4.1.1 Commercial Fishing**

Commercial fisheries play an important role in Maine's economy. Commercial fish and shellfish species of value include American lobster, Atlantic herring, Atlantic salmon (aquaculture), and soft shell clam. In 2011, Maine's commercial fishing industry landed approximately 50 million pounds of fish in Hancock County and approximately 2.5 million pounds of fish in Waldo County, which includes the east and west sides of Penobscot Bay, respectively (DMR 2012b).

Currently, the largest commercial fishery in Penobscot Bay, and Maine in general, is for American lobster. Statewide, lobster accounts for 36% of the live catch by weight and 77% by commercial value as of 2011 (DMR 2012b). UMaine's surveys demonstrated that the area around Castine, including the project area, is targeted by lobster fishermen (Kennedy 2012).

Small pelagic fish are caught using both mid-water trawls and weirs and include such species as herring, menhaden, and sand eels. Of these, Atlantic herring is Maine's most valuable pelagic fishery, with nearly 29,000 tons landed in 2009. While the last cannery in the region closed in April 2010, Atlantic herring remains a critical industry and is the primary bait used by the lobster fishery (UMaine 2011). Herring landings statewide over the last decade ranged from 28,898 to 57,912 tons and were valued from \$4.6 to \$10.7 million. The NOAA Estuarine Living Marine Resources Program compiled information on the distribution and abundance of all life stages of Atlantic herring in estuaries in New England (Jury et al. 1994). Compared to Mid-Atlantic estuaries, adults and juveniles were 'highly abundant' in the northernmost estuaries (Passamaquoddy Bay through Penobscot Bay). Larvae were 'highly abundant' from Englishman-Machias Bays through the Sheepscot River (Jury et al. 1994), an area which includes Penobscot Bay.

The groundfish fishery, or "Northeast multispecies fishery" is managed by the New England Fishery Management Council and NMFS, is primarily an offshore industry (UMaine 2011), and is not applicable to upper Penobscot Bay. With the exception of Atlantic herring, commercial

landings in Maine of species represented commonly in the Maine-New Hampshire Trawl Surveys in the region that includes Penobscot Bay, are mostly very low compared to historical records in the Gulf of Maine and many have trended downward over the decade of the 2000s (DMR 2010).

#### 3.4.1.2 Recreation

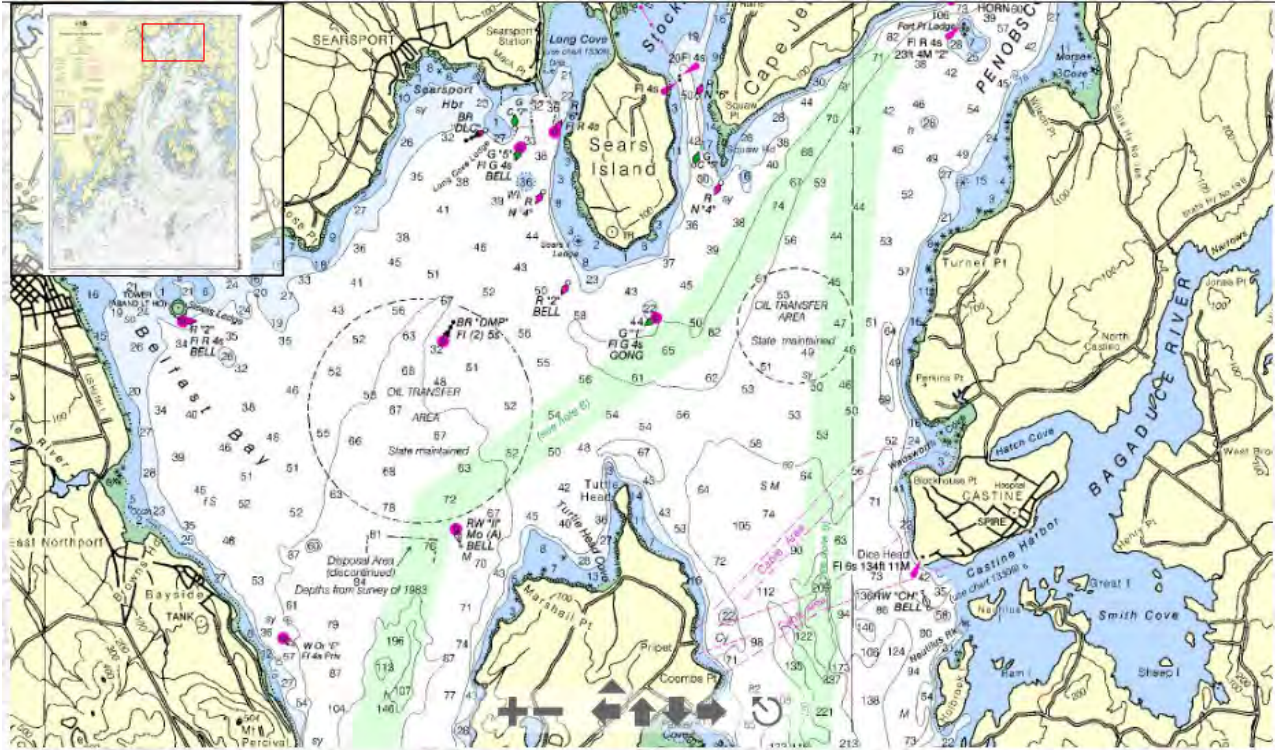
Within Hancock County, which includes the east side of Penobscot Bay, there are six for-hire boats, and within Waldo County, which includes the west side of Penobscot Bay, there are two for-hire boats (DMR 2012a). A number of recreational boating opportunities are available in Castine, including kayaking, boat tours, and sailing (e.g., Castine Yacht Club)(Town of Castine 2012b). The Maine Windjammer Association represents a fleet of 13 traditional Maine tall ships, ranging in size from 46 to 132 feet that offer windjammer cruises out of Rockland, Rockport, and Camden, all located on the west side of lower Penobscot Bay (Maine Windjammer Association 2012). Each summer, lobster boat races are held at Rockland. Additionally, the Gulf of Maine Ocean Racing Association promotes yacht racing in the ocean waters in the Gulf of Maine, including Penobscot Bay (Gulf of Maine Ocean Racing Association 2012). Maine Maritime Academy (2012) also offers a variety of sailing and boating opportunities to its students.

Maine coastal towns are valued for their unique aesthetic character and nautical history. Visitors from around the nation and from other parts of Maine are drawn to the Blue Hill peninsula, which includes Castine, by the scenic natural beauty and historical resource, such as Dyce Head Lighthouse, established in 1828. The grounds are open to the public daily until sunset.

#### 3.4.1.3 Navigation

There are three major ports in Maine: Portland, Searsport, and Eastport. Of these, Castine is closest to Searsport (approximately 6.5 miles to the northwest of the test site). Currently, Maine's three cargo ports handle over 1.5 million tons of dry cargo collectively and roughly 125 million barrels of petroleum products have been handled by Portland and Searsport. In 2007, 33 percent of dry cargo was handled in the Penobscot ports (Searsport, Bucksport, and Bangor) (Maine Dept. of Transportation 2012a). In addition to large-scale commercial shipping, many of Maine's harbors have short-distance freight activity to transport goods and services. Figure 3-4 shows the location of major shipping lanes (Recommended Vessel Routes) in Penobscot Bay.

There are two ferry routes in Penobscot Bay: Lincolnville to Islesboro and Rockland to Vinalhaven/North Haven (Maine Dept. of Transportation 2012b). These ferry routes are approximately nine and 18 miles, respectively, southwest of the test site.



Source: <http://www.charts.noaa.gov/OnLineViewer/13302.shtml>

**Figure 3-4. NOAA chart (13302) showing Recommended Vessel Routes (green shade) in upper Penobscot Bay.**

#### 3.4.1.4 Land Use

As previously mentioned, the terrestrial portion of the project would occur on Dyce Head, north of the light house, in an area dominated by spruce forest and scrub/shrub undergrowth. There are no wetlands. The cable would be laid along the ground across about 300 feet and cross one residential property, from which landowner permission has been granted. The cable would connect to a CMP pole next to the property’s driveway.

### 3.4.2 ENVIRONMENTAL IMPACTS RELATED TO OCEAN AND LAND USE

This section evaluates the potential project effects to the following:

- Ocean use
  - Commercial fishing,
  - Recreation, and
  - Navigation
- Land Use

### 3.4.2.1 Commercial Fishing

When deployed, a navigation safety zone would be established extending around the turbine platform to a distance of approximately 100 feet beyond the anchors. The moorings have a radius of 600 feet, so the navigation safety zone would have a radius of 700 feet, centered on the turbine. This corresponds to an area of approximately 35 acres in which commercial fishing and other public access would be prohibited for the period during which the project is deployed. A navigation safety zone would also extend along the cable. Access would be permitted over the cable safety zone, but anchoring and deploying lobster traps would be prohibited. The development of the Navigational Safety Plan is discussed further in Section 3.4.2.3.

As mentioned, lobstering is prevalent in Penobscot Bay and the project area, as it is along the entire Maine coast. During deployment and removal operations, notice would be given to the Maine Marine Patrol and the USCG to alert fishermen about towing operations and to advise for the removal of gear from the planned tow route.

With the exception of the exclusion zone around the floating platform, lobstering and commercial fishing are expected to otherwise continue in this area. Given the relatively small size of the area covered by the navigation safety zone and the short duration during which the zone would be in effect, the project is anticipated to only minimally reduce or limit lobstering or commercial fishing activities.

### 3.4.2.2 Recreation

Recreational fishermen are expected to continue fishing activities in the greater Castine/eastern Penobscot Bay area with the only change being that they would not be able to enter the 35-acre turbine exclusion area or anchor along the cable route. Any boat that is approaching the turbine platform would have to alter their course by a maximum of 700 feet, and the test site is not expected to affect recreational boaters or cruising vessels approaching or leaving Castine Harbor or navigating through Penobscot Bay. The relatively small area of the navigation safety zone in comparison to the rest of Penobscot Bay and the short duration of the turbine deployment would unlikely reduce the recreational fishing, recreational boating and cruising, and other recreation activity that occurs in the area.

### 3.4.2.3 Navigation

The nearest ports to the project are Searsport, located northwest across Penobscot Bay from Castine, and the Penobscot River ports of Bucksport and Bangor. There are two Recommended Vessel Routes that run the length of Penobscot Bay and the edge of the nearest route is located approximately 3,000 feet west of the proposed deployment location.

Staff of Maine Maritime Academy, which is a partner with UMaine for this project, have developed a navigation safety plan for the project with the USCG Waterways Management division in Boston. In order to prevent vessels from getting hung up on project moorings, a “Navigation Safety Zone” would be established along the cable and within a 700-foot radius around the floating turbine platform. This designation would prohibit all mariners from entering the turbine platform zone, or anchoring along the cable route, for up to four months during which the turbine is deployed. This zone around the turbine would prevent vessels from dragging, anchoring, or fishing within the radius of the anchors and mooring lines.

The turbine would have two lights on the tower, at a height of 20 feet above the water, one on each side of the tower structure. Each light would be a 360°, white flashing light, flashing two short followed by one long flash every four seconds (Morse letter “U”), and visible for at least six miles. The turbine also would have a red Federal Aviation Administration light.

The turbine tower would be clearly labeled (e.g., DCW-1). The label would be large enough and high enough to be readily identifiable to a small vessel nearby. The label would be painted in a contrasting color, retro-reflective material, of a letter size not less than three feet high. The USCG would produce a Local Notice To Mariners warning mariners of the location of the project.

The Navigation Safety Plan, as summarized above, and the small and temporary nature of the project, minimizes the chance of boat collisions with the project.

#### 3.4.2.4 Land Use

For the terrestrial portion of the project, the cable, contained in a conduit, would be laid on and anchored to the ground for up to 300 feet from the high tide line to the interconnect point. Following the approximately four-month project deployment, the cable would be removed.

The cable would cross one private residential property, from which landowner permission has been granted. It would not cross any other properties, and there are no other land use types in the proposed cable pathway. The terrestrial habitat consists of a combination of trees and shrubs. The footprint of the shore component of the project would be small, the cable and other components would be designed and located to minimize terrestrial disturbance (i.e., laying the cable in a conduit on the ground, and not burying it or suspending it from poles), and those components would be deployed for a short duration and removed at the end of the project.

### 3.4.3 NO-ACTION ALTERNATIVE

Under the No-Action Alternative, DOE would not fund the proposed project, installation and operation of the 1/8-scale floating wind turbines would not occur, and there would be no potential impacts to commercial fishing, navigation, and recreation in the project area. Baseline conditions, as described in Section 3.6.1, would remain unchanged.

## 3.5 Cultural Resources

### 3.5.1 AFFECTED ENVIRONMENT

More than 100 historic markers occur in Castine (Town of Castine 2012a), a town characterized by its 18th century Greek revival and federal architecture (National Historic Register 2012). The National Historic Register (2012) lists three historic or archeological districts and four historic properties in Castine:

- Castine Historic District (Figure 3-5, encompasses all of the below sites except for Off-the-Neck Historic District),
- Pentagoet Archeological District,
- Off-the-Neck Historic District,
- Fort George,
- *Bowdoin* (schooner),
- Cate House, and
- John Perkins House.

The Castine Historic District (Figure 3-5) was added to the National Register of Historic Places in 1973. The Pentagoet Archeological District is the site of a trading post built by the French during the 17th century located on the shore of Castine Harbor (National Historic Landmarks Program 2012). The Off-the Neck Historic District is located north of the Castine peninsula, facing the Bagaduce River, and contains a number of dwellings, many in the Federal style of architecture (Downeast and Acadia 2012). Fort George is an earthworks fort built by the British in 1779 during the American Revolutionary War. It has been partially restored as a state memorial. The *Bowdoin* is a historic ship built in 1921 for Arctic exploration and owned by Maine Maritime Academy. Cate House and Perkins House both located in the Village of Castine, are historic colonial residences (National Historic Register 2012). Also, Dyce Head Lighthouse is listed in the inventory of historic light stations and is included in the Castine Historical District. These sites are evaluated in the following environmental impacts section to determine whether they are in the Area of Potential Effects.



Shipwrecks represent an important component of the nautical history of Maine. Perhaps the most well-known shipwrecks in Penobscot Bay were associated with the Penobscot Expedition, an American Revolutionary era expedition to prevent the construction of Fort George. The closest of the known Penobscot Expedition shipwrecks to the proposed test site is that of the privateer *Defence* (Riess and Daniel 1997), which is located in Stockton Harbor, 5.5 miles to the northwest. Other shipwrecks in Penobscot Bay are mostly early 20<sup>th</sup> century shipwrecks located on ledges in southern Penobscot Bay around North Haven, Vinalhaven, and Islesboro (US Naval Shipwreck Database accessed 2012).

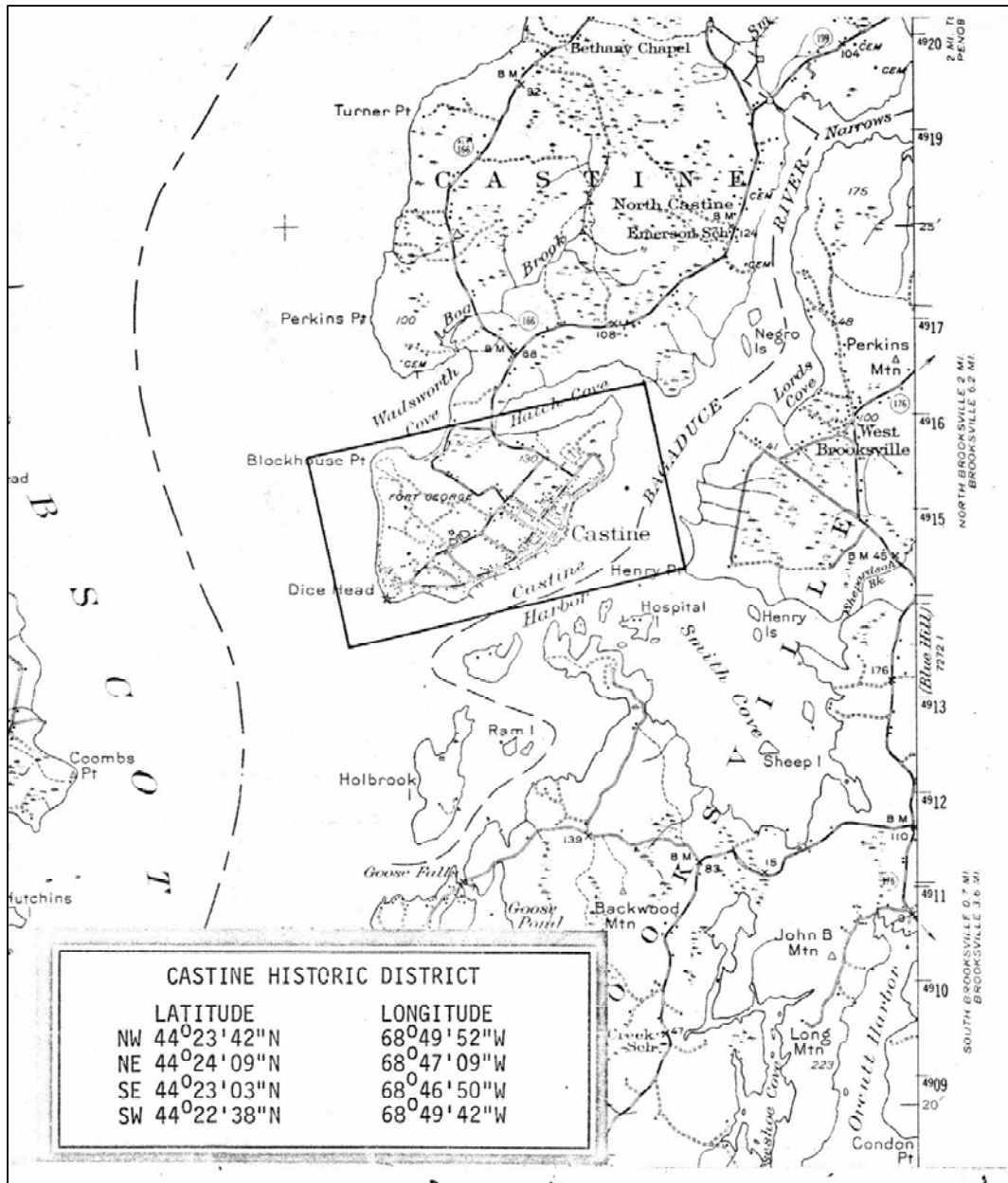


Figure 3-5. Castine Historic District (rectangle).

### 3.5.2 ENVIRONMENTAL IMPACTS RELATED TO CULTURAL RESOURCES

The Penobscot Indian Nation and the Aroostook Band of Micmacs, both in transmittals dated November 29, 2012, indicated that the project did not affect any sites of tribal significance. To comply with obligations under Section 106 of the National Historic Preservation Act, DOE has defined the area of potential effects to historic properties based on two components. First, the area of the seabed that would be directly disturbed by deployment of anchors is included to account for the potential direct effects of the project on shipwrecks. During installation, drag embedment anchors would be pulled about 50 feet in order to set them with 10 feet of penetration. It is anticipated that half of this distance would be within the substrate below the seabed surface. The actual footprint of each anchor would be at most 16 ft<sup>2</sup>, with the four anchors therefore having a combined footprint of about 64 ft<sup>2</sup> and the footprint of the subsea cable and strip weights would be about 357 ft<sup>2</sup>. In the event that gravity anchors are used, each anchor would have a footprint of 100 ft<sup>2</sup> for a combined footprint of 400 ft<sup>2</sup>. Second, the area of the Castine peninsula from which the platform and turbine could be visible is included to address indirect impacts from a change in the viewshed from historic properties; the Castine Historic District as shown in Figure 3-5 has an area of three square miles.

The turbine platform would be located in a previously disturbed cable ROW to minimize the risk of disturbing shipwrecks or other underwater cultural resources. No known shipwrecks have occurred in the project area and no signs of shipwrecks were observed during UMaine's diver surveys conducted in 2012 within the proposed project site. As directed by the Maine SHPO, UMaine staff consulted with Dr. Warren Riess, a marine archaeology professor at UMaine, to further evaluate whether any Penobscot Expedition shipwrecks or other related historic resource concerns could be located in the project area (Pers. comm. R. Reed, Maine SHPO with D. Brady, UMaine, October 18, 2012). In correspondence with SHPO staff, Dr. Riess stated "...that all of the known and assumed locations of the Penobscot Expedition vessel remains are well north of the proposed site, the only exception is the privateer *Defence*, which is miles west of Castine" (Pers. comm. Dr. W. Riess, UMaine with R. Reed, Maine SHPO, October 19, 2012). Dr. Riess oversaw a magnetometer survey conducted at the proposed project site on December 10, 2012, and survey results confirmed that there are no shipwrecks at the site. SHPO stated in a letter dated January 2, 2013 that the project will have no adverse effect on historic properties as defined by Section 106 of the National Historic Preservation Act.

UMaine would locate the turbine off of the western shore of the Castine peninsula in part to minimize its visibility from historic properties. As such, it would not be visible from the Off-the-Neck Historic District or most occupied areas on the peninsula, including much of the Village of Castine, such as where the Cate and Perkins houses and the Pentagoet Archeological District are located and the schooner Bowdoin is docked. The closest historic property to the

proposed turbine location is the Dyce Head lighthouse, which is accessible to the public. The turbine would not be visible from that lighthouse (Figure 3-6) or from some other areas on the west side of the peninsula because of the steep shoreline and dense vegetation there. However, the turbine might be visible from some areas along the western portion of the Castine Historic District and from some of the higher points on the peninsula, such as where Fort George is located. There likely are some properties in the areas where the turbine could be viewed that are eligible for listing under the National Register of Historic Places. Because the 1/8-scale turbine would have a maximum height of 57 feet above the waterline, it would appear small from any location within the Castine Historic District or elsewhere on the peninsula, and would not dominate or otherwise substantially change the view from historic properties. In addition, because the turbine would be deployed for less than four months, any change in the view from an historic property would be temporary.



**Figure 3-6. View from the base of Dyce Head Lighthouse toward the shore.**

Based on this analysis, DOE has concluded in the Section 106 consultation letter to the Maine SHPO that there would be no direct adverse impacts to underwater historic properties from deployment and retrieval of the floating platform or indirect adverse impacts to the viewshed from historic properties on the Castine peninsula. SHPO concluded the same in their letter dated January 2, 2013.

### **3.5.3 NO-ACTION ALTERNATIVE**

Under the No-Action Alternative, DOE would not fund the proposed project, installation and operation of the 1/8-scale floating wind turbine would not occur. Therefore, no potential impacts to cultural resources would occur. Baseline conditions, as described in Section 3.5.1, would remain unchanged.

### **3.6 Irreversible and Irrecoverable Commitments of Resources**

An irreversible commitment of resources is defined as the loss of future options. The term applies primarily to the effects of use of nonrenewable resources such as minerals or cultural resources. It could also apply to the loss of an experience as an indirect effect of a “permanent” change in the nature or character of the land. An irrecoverable commitment of resources is defined as the loss of production, harvest, or use of natural resources. The amount of production foregone is irrecoverable, but the action is not irreversible. If the use changes, it is possible to resume production.

Irreversible commitments of resources would result from resources being consumed during construction of the project, including fossil fuels and construction materials, which would be committed for the less than one year-life of the project. Non-renewable fossil fuels would be lost through the use of gasoline and diesel-powered construction equipment during deployment and removal of one small-scale floating wind turbine, project operations, and monitoring efforts.

The 700-foot radius navigation safety zone around the turbine corresponds to an area of approximately 35 acres for which commercial fishing and other public access would be prohibited for the period during which the project components are deployed. In addition, anchoring or setting lobster pots would not be permitted along the cable route for the four-month project deployment. While there may be some resulting catch of lobster and fish foregone, fish and lobsters would still be able to be caught when they move outside the exclusion area.

The proposed project would not have other irreversible or irrecoverable impacts because the project is short term and temporary; removal of the turbine after the second year of testing would restore the site for alternative uses, including all current uses. No loss of future ocean use options would occur.

### **3.7 The Relationship Between Local Short-Term Uses of the Human Environment and the Maintenance and Enhancement of Long-Term Productivity**

Short-term use of the environment, as the term is used in this document, is that used during the life of the project, whereas long-term productivity refers to the period of time after the project has been decommissioned and the equipment removed. As the proposed project would be temporary, there would not be a change in ocean use. The short-term use of the site for the proposed project would not affect the long-term productivity of the test site area.

## 4.0 CUMULATIVE IMPACTS

Cumulative impacts are those potential environmental impacts that result “from the incremental impact of the action when added to other past, present, or reasonably foreseeable future actions regardless of what agency (federal or non-federal) or person undertakes such actions. Cumulative impacts can result from individually minor but collectively significant actions taking place over a period of time” (40 CFR 1508.7). Because of the small scale and temporary nature of the proposed project, any negative effects on existing human use of the area would be negligible and temporary.

Following testing of the proposed turbine at Castine for up to four months, UMaine is planning to move the turbine to the Monhegan site for additional testing. It is expected that the turbine would be tested for less than one month at the Monhegan site in 2013. In addition, UMaine may conduct testing at the Monhegan site the following year as well.

In October 2011, Statoil filed an Unsolicited Lease Application with the Bureau of Ocean Energy Management to develop a 12-MW pilot project, consisting of four 3-MW floating turbines in federal waters about 12 nautical miles southeast of Boothbay Harbor. Statoil is currently investigating the feasibility of the project with the State of Maine. Initially, Statoil planned to install the project in 2016.

UMaine is also beginning work on engineering and planning for the possible installation of a pilot floating offshore wind farm with two 6-MW direct-drive turbines on concrete semi-submersible foundations at the Monhegan test site. Pending required approvals by the Department of Energy and other regulatory agencies, the target date for deployment would be 2016.

During the four months that the 1/8-scale turbine would be deployed at Castine, combined with the subsequent deployment for up to one month at Monhegan, the proposed project might cumulatively add to the risk of foraging and migrating bird and bats colliding with man-made structures in the area. Birds and bats are known to collide with numerous man-made structures such as vehicles, buildings and windows, power lines, communication towers, and wind turbines. It is estimated that from 100 million to over 1 billion birds are killed annually in the U.S. due to collisions with manmade structures (Erickson et al. 2001).

The proposed future deployments by Statoil and UMaine in 2016 would occur at least three years after the Castine deployment has been removed. As discussed in this Supplemental EA, effects of the proposed project at the Castine site would be short term and would end with the removal of the project after four months or less of operation. Thus, the proposed deployment at Castine would not cumulatively contribute to other future effects of those projects.

## 5.0 REFERENCES

- Akamatsu, T., D. Wang, K. Wang, and Y. Naito. 2005. Biosonar behaviour of free-ranging porpoises. *Proc. R. Soc. B* (2005) 272, 797–801. doi:10.1098/rspb.2004.3024. Published online 22 April 2005.
- Biodiversity Research Institute. 2012. Birds, Bats, and Coastal Windfarm Development in Coastal Maine: Preliminary Ranking of Bird Use. Biodiversity Research Institute. [Online] URL: <http://www.briloon.org/oa/the-science-of-bri/tracking-wildlife/birds-bats-costal-windfarm-development> (Accessed July 29, 2012).
- Bradley, D.L. and R. Stern. 2008. Underwater Sound and the Marine Mammal Acoustic Environment, A Guide to Fundamental Principles. Prepared for the U.S. Marine Mammal Commission. [Online] URL: [http://www.mmc.gov/reports/workshop/pdf/sound\\_bklet.pdf](http://www.mmc.gov/reports/workshop/pdf/sound_bklet.pdf) (Accessed July 2008).
- DeGraaf, R.M. and M. Yamasaki. 2001. New England Wildlife; Habitat, Natural History, and Distribution. University Press of New England, Hanover, NH. 482p. *cited in* Stantec 2012.
- Dehnhardt, G., B. Mauck, W. Hanke and H. Bleckmann. 2001. Hydrodynamic Trail-Following in Harbor Seals (*Phoca vitulina*). *Science*. 293(5527): 102-104.
- Downeast and Acadia. 2012. Castine Historic District. [Online] URL: [http://www.downeastacadia.com/highlights/history/historic\\_districts/castine\\_historic\\_district/](http://www.downeastacadia.com/highlights/history/historic_districts/castine_historic_district/). Accessed November 2012.
- Erickson, W.P., G.D. Johnson, M.D. Strickland, D.P. Young, K.J. Sernka and R.E. Good. 2001. *Avian Collisions with Wind Turbines: A Summary of Existing Studies and Comparisons to Other Sources of Avian Collision Mortality in the United States*. Prepared by Western EcoSystems Technology, Inc., Cheyenne, Wyo., for the National Wind Coordinating Committee, Washington, D.C.
- Federal Energy Regulatory Commission (FERC). 2007. *Environmental Assessment for Hydropower License. Makah Bay Offshore Wave Energy Pilot Project*. FERC Project No. 12751-000. May 21, 2007.
- Gulf of Maine Council 2005. *Workshop Proceedings of Marine Habitats in the Gulf of Maine: Assessing Human Impacts and Developing Management Strategies*. 2005. Organized by the Gulf of Maine Council on the Marine Environment's Habitat Conservation

- Subcommittee and The Nature Conservancy. Walpole, Maine. September 21–22, 2005. [Online] URL: <http://www.gulfofmaine.org/council/publications/marine-habitat-workshop-proceedings.pdf>.
- Gulf of Maine Ocean Racing Association. 2012. Race Schedule. [Online] URL: <http://www.gmora.org/shopcontent.asp?type=2012>. Race Schedule (Accessed October 2012).
- Jones, M., P. Ramuhalli, and M. Watkins. 2010. *Characterization of acoustic noise propagation from offshore wind turbines – white paper*. Pacific Northwest National Laboratory, Richland, WA. Unpublished.
- Jury, S.H., J.D. Field, S.L. Stone, D.M. Nelson, and M.E. Monaco. 1994. Distribution and abundance of fishes and invertebrates in North Atlantic estuaries. ELMR Rep. No. 13, NOAA/NOS /Strategic Environmental Assessments Division, Silver Spring, MD. 221 p.
- Kennedy, L. 2012. Visual Observations for Birds, Turtles, and Marine Mammals at the University of Maine Test Site near Castine, Maine. Prepared by Lubird Kennedy Environmental Services for the University of Maine’s Advanced Structures and Composites Center. September, 2012.
- Kunz, T.H., E. Arnett, W. Erickson, A. Hoar, G. Johnson, R. Larkin, M.D. Strickland, R. Thresher and M. Tuttle. 2007. Ecological impacts of wind energy development on bats: questions, research needs, and hypotheses. *Font Ecol Environ* 5 (6): 315-324. [Online] URL: [http://www.migrate.ou.edu/products/Kunz\\_etal1\\_07.pdf](http://www.migrate.ou.edu/products/Kunz_etal1_07.pdf)
- Maine Department of Marine Resources (DMR). 2012a. Maine's Saltwater For-Hire Fleet Listing. [Online] URL: <http://www.maine.gov/dmr/recreational/forhirefleet/index.htm> (Accessed October 2012).
- Maine Department of Marine Resources (DMR). 2012b. Most Recent Maine Commercial Landings. [Online] URL: <http://www.maine.gov/dmr/commercialfishing/recentlandings.htm>.
- Maine Department of Marine Resources (DMR). 2010. Historical Maine Fisheries Landings Data. [Online] URL: <http://www.maine.gov/dmr/commercialfishing/historicaldata.htm>. (Accessed October 2012).

- Maine Department of Transportation (MDOT). 2012a. Office of Freight and Business Services. Cargo Ports. [Online] URL: <http://www.maine.gov/mdot/ofbs/cargo.htm>. (Accessed October 2012).
- Maine Department of Transportation (MDOT). 2012b. Maine State Ferry Service. [Online] URL: <http://www.maine.gov/mdot/msfs/> (Accessed October 2012).
- Maine Maritime Academy. 2012. Online [URL]: <http://www.mainemaritime.edu/> (Accessed October 2012).
- Maine Windjammer Association. 2012. About MWA. [Online] URL: <http://www.sailmainecoast.com/fleetfacts.htm> (Accessed October 2012).
- Mills, F.H.J. and D. Renouf. 1986. Determination of the vibration sensitivity of harbour seal *Phoca vitulina* (L.) vibrissae. *Journal of Experimental Marine Biology and Ecology*. Volume 100, Issues 1-3, pp 3-9. September 1986.
- Minerals Management Service (MMS). 2007. *Draft Programmatic EIS for alternative energy development and production and alternative use of facilities on the Outer Continental Shelf*. U.S. Department of the Interior. March 2007.
- National Historic Landmarks Program. 2012. Pentagoet Archeological District. [Online] URL: <http://tps.cr.nps.gov/nhl/detail.cfm?ResourceId=2148&ResourceType=>. Accessed November 2012.
- National Marine Fisheries Service (NMFS). 2012. Biological Opinion, Construction of new powerhouses at the Orono (2710) and Stillwater (2712) Projects; Fish passage improvements at the Orono, Stillwater and Milford (2534) Projects; Species Protection Plan for the Orono, Stillwater, Milford, West Enfield (2600) and Medway (2666) Projects. F~RJ2012/01568. August 31, 2012. [Online] URL: [http://www.nero.noaa.gov/prot\\_res/section7/FERC-signedBOs/Black-BearHydroBO.pdf](http://www.nero.noaa.gov/prot_res/section7/FERC-signedBOs/Black-BearHydroBO.pdf)
- National Oceanic and Atmospheric Administration (NOAA). 2012. Guide to Essential Fish Habitat Designations in the Northeastern United States. [Online] URL: <http://www.nero.noaa.gov/hcd/index2a.htm>. (Accessed October 2012).
- National Register of Historic Places. 2012. Maine – Hancock County. [Online] URL: <http://www.nationalregisterofhistoricplaces.com/me/Hancock/state.html>. Accessed November 2012.



- Nelson, P.A. 2003. Marine fish assemblages associated with fish aggregating devices (FADs): Effects of fish removal, FAD size, fouling communities, and prior recruits. *Fishery Bulletin*. 101: 835-850.
- Renewegy. 2012. Archive for the 'Renewegy Blog' Category. [Online] URL: <http://renewegy.com/category/blog/> (Accessed October 2012).
- Richardson, W.J.; Greene, Jr., C.R.; Malme, C.I.; and Thomson, D.H. 1995. *Marine Mammals and Noise*. Academic Press, London.
- Riess, W. and G. Daniel. 1997. Evaluation of preservation efforts for the Revolutionary War privateer *Defence*. *International Journal of Nautical Archaeology* 26: 330-338.
- Schusterman, R.J. and R.F. Balliet. 1970. Visual Acuity of the Harbour Seal and the Steller Sea Lion Under Water. *Nature*. Vol. 226, No. 5245, pp. 563-564, 1970.
- Sherman, S.A., Stepanek, K.L., King, C., Gowen, A.M., Tetrault, R., Michael, R., and Ekert, R. 2010. Annual Report on the Maine-New Hampshire Inshore Trawl Survey. Submitted to the NOAA Fisheries Northeast Region Cooperative Research Partners Program.
- Sherwood, G. K. Wilson, J. Grabowski and T. Willis. 2012. Penobscot River Restoration: Monitoring Marine-Freshwater Food Web Linkages Using Stable Isotopes, Phase One sample collection and trial analysis. A final report to The Nature Conservancy.
- Stantec Consulting Services, Inc (Stantec). 2012. Acoustic Bat Survey Report Dice Head Lighthouse Castine, Maine. Prepared for DeepCWind, University of Maine Darling Marine Center. August 2012.
- Town of Castine. 2012a. [Online] URL: <http://www.castine.me.us/index.html>. Accessed November 2012.
- Town of Castine. 2012b. Businesses. [Online] URL: <http://www.castine.me.us/pages/business/business.html> (Accessed October 2012).
- U.S. Department of Energy (DOE). 2011. Final Environmental Assessment for University of Maine's Deepwater offshore Floating Wind Turbine Testing and Demonstration Project, Gulf of Maine. DOE, Office of Energy Efficiency and Renewable Energy, Golden Field Office. September 2011. Available online at: [http://www.eere.energy.gov/golden/NEPA\\_FEA\\_FONSI.aspx](http://www.eere.energy.gov/golden/NEPA_FEA_FONSI.aspx).

- U.S. Environmental Protection Agency (USEPA). 2007. Environmental Monitoring and Assessment Program (EMAP) Storage and Retrieval (STORET) Data Warehouse. 1998-2006. [Online] URL: <http://www.epa.gov/storet/>. (Accessed October 2012)
- U.S. Fish and Wildlife Service (USFWS). 2008. Birds of Conservation Concern 2008. United States Department of Interior, Fish and Wildlife Service, Division of Migratory Bird Management, Arlington, Virginia. 85 pp. [Online] URL: <http://www.fws.gov/migratorybirds/>. (Accessed October 2012)
- University of Maine (UMaine). 2011. *Draft Report on Existing Marine Resources and Draft Fish and Wildlife Monitoring Plan*. University of Maine Deepwater Offshore Wind Test Site. Unpublished. March 2011.
- Wursig, B. and G.A. Gaily. 2002. Marine mammals and aquaculture: conflicts and potential resolutions. In Stickney, R.R. and J.P. McVay (Eds.) *Responsible Marine Aquaculture*. CAP International Press, New York, pp. 45-59.
- Zydlewski, G.B. 2012. Dice Head Acoustic Receiver Array Detections 2009-2011. Data collected by: University of Maine, School of Marine Sciences and School of Biology and Ecology; NOAA Fisheries Maine Field Station, NEFSC; and USGS Maine Cooperative Fish and Wildlife Research Unit.
- Zydlewski, G.B., Kinnison, M.T., Dionne, P.E., Zydlewski, J., Wippelhauser, G.S. 2011. Understanding habitat connectivity for shortnose sturgeon: the importance of small coastal rivers. *Journal of Applied Ichthyology* 47(Suppl. 1): 1-4.

**APPENDIX A**  
**CONSULTATION LETTERS**



## Department of Energy

Golden Field Office  
1617 Cole Boulevard  
Golden, Colorado 80401-3393

October 18, 2012

Mr. Mike Johnson  
Marine Habitat Resource Specialist  
National Marine Fisheries Service, Northeast Region  
55 Great Republic Drive  
Gloucester, MA 01930

Dear Mr. Johnson:

**Subject: Request for Information - University of Maine Testing of a Floating Offshore Wind Turbine Platform, Castine, Maine**

The U.S. Department of Energy (DOE) is proposing to award federal funding to the University of Maine to construct, deploy, and retrieve one small-scale floating turbine offshore of Maine. In September 2011 DOE completed an Environmental Assessment (EA) evaluating the potential effects of the University's plans to deploy two 1/3-scale wind turbines on floating platforms within the deepwater offshore wind test site in the Gulf of Maine near Monhegan Island. In a letter dated August 6, 2011, your agency concurred with DOE's conclusions that (1) the proposed action is not likely to adversely affect any threatened or endangered species under your jurisdiction and (2) that adverse effects to essential fish habitat would be minimal. Your agency also stated in that letter that you did not anticipate any impacts to marine mammals from the proposed action.

The University has since downscaled the size of their planned platform and turbine from 1/3 scale to 1/8 scale. Because of this change to a smaller size, for part of the year the platform and turbine would be deployed at a more sheltered nearshore location, near Castine Harbor, Maine for initial testing (see attached figure). The University proposes to deploy a Renewegy wind turbine with a power rating of 20 kilowatts onto a floating platform. The platform would be located in an existing cableway in water that is 40 to 70 feet deep. The turbine would measure about 41 feet high from the waterline to the hub, the rotor diameter would be about 32 feet, and the total height of the turbine above the water line would be about 57 feet. The platform would be moored with drag embedment anchors and catenary mooring lines. The turbine would be connected to the Central Maine Power grid via a cable to be temporarily installed about 500 to 1,000 feet along the seabed to shore.



The platform would be deployed around March/April through July/August 2013, and its performance would be monitored to study the design prior to deployment in the open ocean at Monhegan Island. During the deployment at Castine, the University would use sensors and telemetry systems to be installed on the platform to evaluate how it performs under varying wind and wave conditions. Environmental monitoring for birds, bats, marine mammals, benthic invertebrates, and fish also would occur. Prior to DOE's involvement with the proposed Castine site test, the University conducted pre-deployment environmental monitoring and data collection for birds, bats, marine mammals, benthic invertebrates, and fish.

DOE understands that the University has reached out to you recently regarding their pre-deployment environmental monitoring for the Castine deployment. DOE requests that NMFS provide any information relevant to our federal obligations that relates to the referenced project (e.g., Endangered Species Act [ESA], Magnuson-Stevens Fishery Conservation and Management Act, Fish and Wildlife Coordination Act, and Marine Mammal Protection Act). Specifically, DOE requests a list of species listed under the ESA and proposed and designated critical habitat that may occur within or near the project site. DOE also requests that NMFS confirm the list of 17 federally managed fish species and respective life stages for which Essential Fish Habitat occurs in waters off of Castine, as presented in Table 1, which was developed from review of NMFS' *Guide to Essential Fish Habitat Designations in the Northeastern United States*.

**Table 1 – Marine Species and Life Stages for which Essential Fish Habitat Occurs in Waters off of Castine**

Species	Eggs	Larvae	Juveniles	Adults
Atlantic salmon ( <i>Salmo salar</i> )			X	X
Atlantic cod ( <i>Gadus morhua</i> )		X	X	X
pollock ( <i>Pollachius virens</i> )			X	
whiting ( <i>Merluccius bilinearis</i> )			X	X
red hake ( <i>Urophycis chuss</i> )			X	X
white hake ( <i>Urophycis tenuis</i> )			X	X
winter flounder ( <i>Pseudopleuronectes americanus</i> )	X	X	X	X
yellowtail flounder ( <i>Limanda ferruginea</i> )	X	X		
windowpane flounder ( <i>Scophthalmus aquosus</i> )	X	X	X	X
American plaice ( <i>Hippoglossoides platessoides</i> )	X	X	X	X

ocean pout ( <i>Macrozoarces americanus</i> )	X	X	X	X
Atlantic sea scallop ( <i>Placopecten magellanicus</i> )	X	X	X	X
Atlantic sea herring ( <i>Clupea harengus</i> )		X	X	X
monkfish ( <i>Lophius americanus</i> )				
bluefish ( <i>Pomatomus saltatrix</i> )			X	X
Atlantic mackerel ( <i>Scomber scombrus</i> )			X	X
bluefin tuna ( <i>Thunnus thynnus</i> )				X

Source: NOAA. 2012. Guide to Essential Fish Habitat Designations in the Northeastern United States:

<http://www.nero.noaa.gov/hcd/STATES4/nmaine.htm>. (Accessed October 2012)

DOE is in the process of developing a Supplemental EA to cover these new activities proposed at the Castine site. We will notify you when the Draft of that Supplemental EA is available for your review.

DOE looks forward to working collaboratively with NMFS regarding trust resources as they relate to this project. If you have any questions, please contact me at 720-356-1322 or via email at [Laura.Margason@go.doe.gov](mailto:Laura.Margason@go.doe.gov).

Sincerely,

Laura Margason  
NEPA Document Manager

Attachment (map)

cc:

David Bean, National Marine Fisheries Service

Michelle Magliocca, National Marine Fisheries Service



## Department of Energy

Golden Field Office  
1617 Cole Boulevard  
Golden, Colorado 80401-3393

October 18, 2012

Mr. Mark McCollough  
Field Supervisor  
U.S. Fish & Wildlife Service  
17 Godfrey Drive, Suite 2  
Orono, ME 04473

Dear Mr. McCollough:

**Subject: Request for Information - University of Maine Testing of a Floating Offshore Wind Turbine Platform, Castine, Maine**

The U.S. Department of Energy (DOE) is proposing to award federal funding to the University of Maine to construct, deploy, and retrieve one small-scale floating turbine offshore of Maine. In September 2011 DOE completed an Environmental Assessment (EA) evaluating the potential effects of the University's plans to deploy two 1/3-scale wind turbines on floating platforms within the deepwater offshore wind test site in the Gulf of Maine near Monhegan Island. In a letter dated August 18, 2011, your office concurred with DOE's conclusion that that proposed action may affect, but is unlikely to adversely affect, terrestrial threatened or endangered species.

The University has since downscaled the size of their planned platform and turbine from 1/3 scale to 1/8 scale. Because of this change to a smaller size, for part of the year the platform and turbine would be deployed at a more sheltered nearshore location, near Castine Harbor, Maine (see attached figure). The University proposes to deploy on a floating platform a Renewegy wind turbine with a power rating of 20 kilowatts. The platform would be located in an existing cableway in water that is 40 to 70 feet deep. The turbine would measure about 41 feet from the waterline to the hub, the rotor diameter would be about 32 feet, and the total height of the turbine above the water line would be up to about 57 feet, similar in size to a large sailboat. The platform would be moored with drag embedment anchors, which are similar to sailboat anchors, and catenary mooring lines. The turbine would be connected to the Central Maine Power grid via a cable to be temporarily installed about 500 to 1,000 feet along the seabed to shore. From just below the low tide line the cable would extend approximately 500 feet along the ground in a protective conduit to the point of interconnection at an existing power pole. The conduit would be removed at the end of the project.



The platform would be deployed from about March or April through to July 2013, and its performance would be monitored to study the design prior to deployment in the open ocean at Monhegan Island. During the deployment at Castine, the University would use sensors and telemetry systems to be installed on the platform to evaluate how it performs under varying wind and wave conditions. Environmental monitoring for birds, bats, marine mammals, benthic invertebrates, and fish also would occur. The University has already conducted pre-deployment environmental monitoring and existing data collection for birds, bats, marine mammals, benthic invertebrates, and fish for this site.

DOE understands that the University has reached out to you recently regarding pre-deployment environmental monitoring for the Castine deployment and for the 20kw turbine erection on the University of Maine campus for instrumentation prior to Castine deployment. DOE requests that USFWS provide any information relevant to our federal obligations that relates to the referenced project (e.g., Endangered Species Act [ESA]). Specifically, DOE requests a list of species listed under the ESA and proposed and designated critical habitat that may occur within or near the project site.

DOE is in the process of developing a Supplemental EA to cover these new activities off of Castine. We will notify you when the Draft of that Supplemental EA is available for your review.

The DOE looks forward to working collaboratively with the USFWS regarding trust resources as they relate to this project. If you have any questions, please contact me at 720-356-1322 or via my email at [Laura.Margason@go.doe.gov](mailto:Laura.Margason@go.doe.gov).

Sincerely,



Laura Margason  
NEPA Document Manager

Attachment (map)





## Department of Energy

Golden Field Office  
1617 Cole Boulevard  
Golden, Colorado 80401-3393

November 2, 2012

Chief Richard Getchell  
Aroostook Band of Micmacs  
7 Northern Road  
Presque Isle, ME 04769

**Subject: University of Maine Testing of a Floating Offshore Wind Turbine Platform, Castine, Maine**

To Chief Richard Getchell:

The U.S. Department of Energy (DOE) is proposing to provide federal funding to the University of Maine (UMaine) to construct, deploy, and retrieve one small-scale floating turbine offshore of Maine. The objective of this project is to validate coupled aeroelastic/hydrodynamic computer models developed by the National Renewable Energy Laboratory and others for floating offshore wind turbines.

In September 2011 DOE completed an Environmental Assessment (EA) evaluating the potential effects of the University's plans to deploy two 1/3-scale wind turbines on floating platforms within the deepwater offshore wind test site in the Gulf of Maine near Monhegan Island. The University has since downscaled the size of their planned platform and turbine from 1/3 scale to 1/8 scale. Because of this change to a smaller size, for part of the year the platform and turbine would be deployed at a more sheltered nearshore location, near Castine Harbor, Maine (see attached figure).

The University proposes to deploy a 20 kilowatt power rated Renewegy wind turbine onto a moored floating platform. The platform would be located in an existing cableway in water that is 40 to 70 feet deep. The turbine would measure about 41 feet from the waterline to the hub, the rotor diameter would be about 32 feet, and the total height of the turbine above the water line would be up to about 57 feet. The platform would be moored with drag embedment anchors, which are similar to sailboat anchors, and catenary mooring lines. The turbine would be connected to the Central Maine Power grid via a cable to be temporarily installed about 500 to 1,000 feet along the seabed to shore. From just below the low tide line the cable would extend approximately 500 feet along the ground in a protective conduit to the point of interconnection at an existing power pole. The conduit would be removed at the end of the project.

The platform would be deployed for about four to five months, starting in the spring of 2013, and its performance would be monitored to study the design prior to deployment in the open ocean at Monhegan Island. During the deployment at Castine, the University would use sensors and telemetry systems installed on the platform to evaluate how it performs under varying wind and wave conditions. Environmental monitoring for birds, bats, marine mammals, benthic invertebrates, and fish would also take place post deployment. The University has already conducted pre-deployment environmental monitoring and data collection for birds, bats, marine mammals, benthic invertebrates, and fish for this site to assist in determining affects to these



resources.

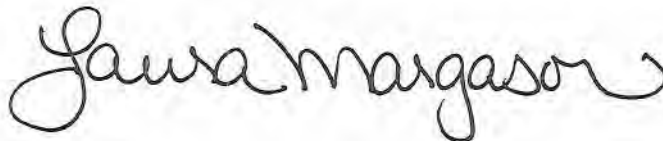
A Supplemental Environmental Assessment (EA) is currently being prepared for the proposed Castine site project by the Department's Golden Field Office to meet the requirements of the *National Environmental Policy Act*. DOE will include correspondence with your tribe in an appendix to the EA. The draft EA, when it is available, will be posted in the DOE Golden Field Office online reading room: [http://www.eere.energy.gov/golden/NEPA\\_DEA.aspx](http://www.eere.energy.gov/golden/NEPA_DEA.aspx). You will receive a notice of availability once the draft EA is posted. Please contact DOE if you would like to receive a hardcopy of the document.

Per the regulations of the Advisory Council on Historic Preservation at 36 CFR Section 800.2(c)(5), DOE is requesting information your tribe may have on properties of traditional religious and cultural significance within the vicinity of the proposed deployment near Castine Harbor and any comments or concerns you have on the potential for this proposed project to affect those properties. This information is being requested to aid in the preparation of that Environmental Assessment and to comply with the National Historic Preservation Act. If you have any such information, require additional information, have any questions or comments about that project or would like DOE to initiate formal consultation, please contact Ms. Laura Margason the Golden Field Office as soon as possible at the following:

Ms. Laura Margason  
U.S. Department of Energy  
1617 Cole Boulevard  
Golden, Colorado  
Email: [laura.margason@go.doe.gov](mailto:laura.margason@go.doe.gov)

Thank you in advance for your consideration.

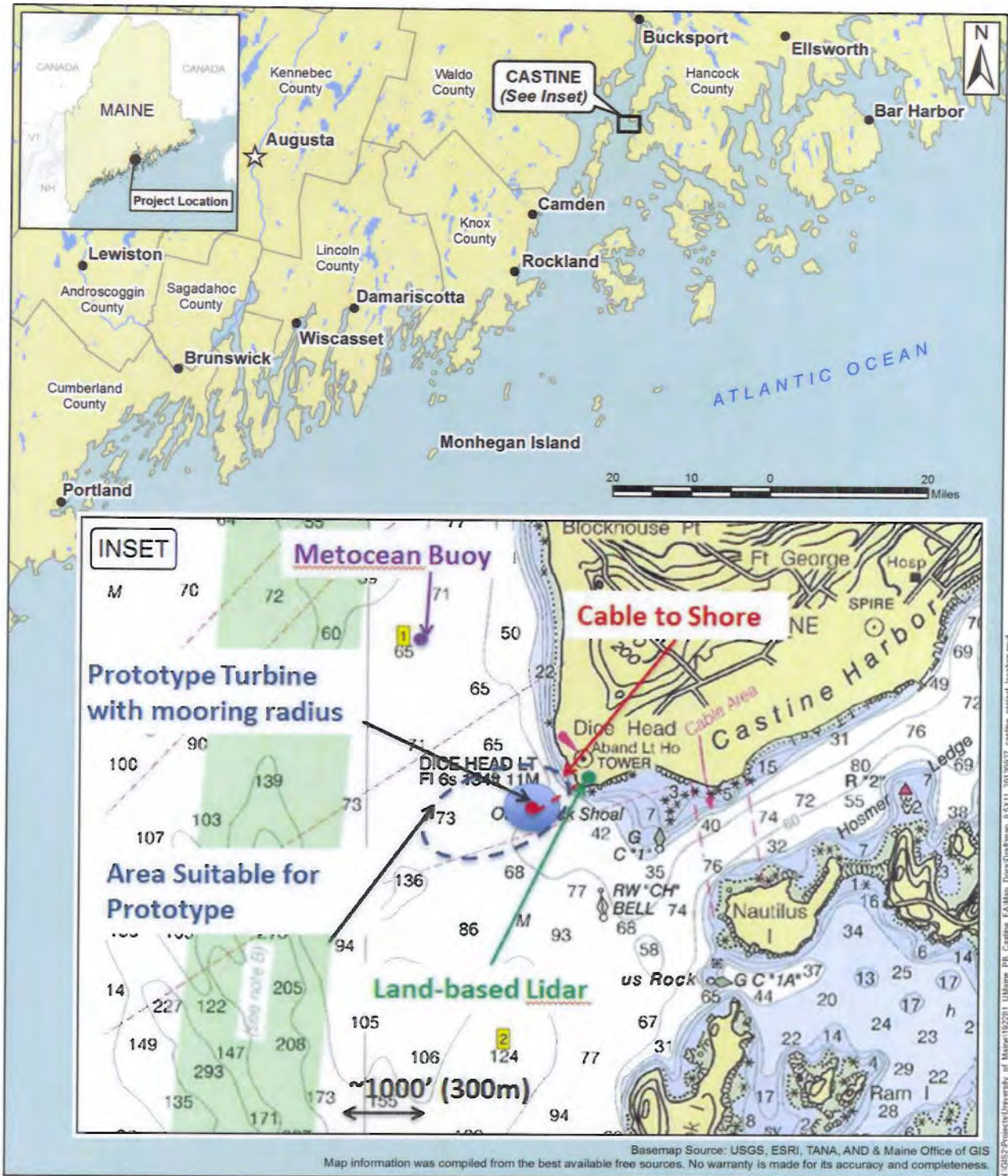
Sincerely,

A handwritten signature in black ink that reads "Laura Margason". The signature is written in a cursive, flowing style.

Laura Margason  
DOE NEPA Document Manager

Attached: Project Location Map

# Project Location of University of Maine Testing of a Floating Offshore Wind Turbine Platform, Castine, Maine





## Department of Energy

Golden Field Office  
1617 Cole Boulevard  
Golden, Colorado 80401-3393

November 2, 2012

Chief Brenda Commander  
Houlton Band of Maliseet Indians  
88 Bell Road  
Littleton, ME 04730

**Subject: University of Maine Testing of a Floating Offshore Wind Turbine Platform, Castine, Maine**

To Chief Brenda Commander:

The U.S. Department of Energy (DOE) is proposing to provide federal funding to the University of Maine (UMaine) to construct, deploy, and retrieve one small-scale floating turbine offshore of Maine. The objective of this project is to validate coupled aeroelastic/hydrodynamic computer models developed by the National Renewable Energy Laboratory and others for floating offshore wind turbines.

In September 2011 DOE completed an Environmental Assessment (EA) evaluating the potential effects of the University's plans to deploy two 1/3-scale wind turbines on floating platforms within the deepwater offshore wind test site in the Gulf of Maine near Monhegan Island. The University has since downscaled the size of their planned platform and turbine from 1/3 scale to 1/8 scale. Because of this change to a smaller size, for part of the year the platform and turbine would be deployed at a more sheltered nearshore location, near Castine Harbor, Maine (see attached figure).

The University proposes to deploy a 20 kilowatt power rated Renewegy wind turbine onto a moored floating platform. The platform would be located in an existing cableway in water that is 40 to 70 feet deep. The turbine would measure about 41 feet from the waterline to the hub, the rotor diameter would be about 32 feet, and the total height of the turbine above the water line would be up to about 57 feet. The platform would be moored with drag embedment anchors, which are similar to sailboat anchors, and catenary mooring lines. The turbine would be connected to the Central Maine Power grid via a cable to be temporarily installed about 500 to 1,000 feet along the seabed to shore. From just below the low tide line the cable would extend approximately 500 feet along the ground in a protective conduit to the point of interconnection at an existing power pole. The conduit would be removed at the end of the project.

The platform would be deployed for about four to five months, starting in the spring of 2013, and its performance would be monitored to study the design prior to deployment in the open ocean at Monhegan Island. During the deployment at Castine, the University would use sensors and telemetry systems installed on the platform to evaluate how it performs under varying wind and wave conditions. Environmental monitoring for birds, bats, marine mammals, benthic invertebrates, and fish would also take place post deployment. The University has already conducted pre-deployment environmental monitoring and data collection for birds, bats, marine mammals, benthic invertebrates, and fish for this site to assist in determining affects to these



resources.

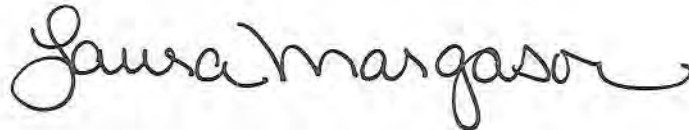
A Supplemental Environmental Assessment (EA) is currently being prepared for the proposed Castine site project by the Department's Golden Field Office to meet the requirements of the *National Environmental Policy Act*. DOE will include correspondence with your tribe in an appendix to the EA. The draft EA, when it is available, will be posted in the DOE Golden Field Office online reading room: [http://www.eere.energy.gov/golden/NEPA\\_DEA.aspx](http://www.eere.energy.gov/golden/NEPA_DEA.aspx). You will receive a notice of availability once the draft EA is posted. Please contact DOE if you would like to receive a hardcopy of the document.

Per the regulations of the Advisory Council on Historic Preservation at 36 CFR Section 800.2(c)(5), DOE is requesting information your tribe may have on properties of traditional religious and cultural significance within the vicinity of the proposed deployment near Castine Harbor and any comments or concerns you have on the potential for this proposed project to affect those properties. This information is being requested to aid in the preparation of that Environmental Assessment and to comply with the National Historic Preservation Act. If you have any such information, require additional information, have any questions or comments about that project or would like DOE to initiate formal consultation, please contact Ms. Laura Margason the Golden Field Office as soon as possible at the following:

Ms. Laura Margason  
U.S. Department of Energy  
1617 Cole Boulevard  
Golden, Colorado  
Email: [laura.margason@go.doe.gov](mailto:laura.margason@go.doe.gov)

Thank you in advance for your consideration.

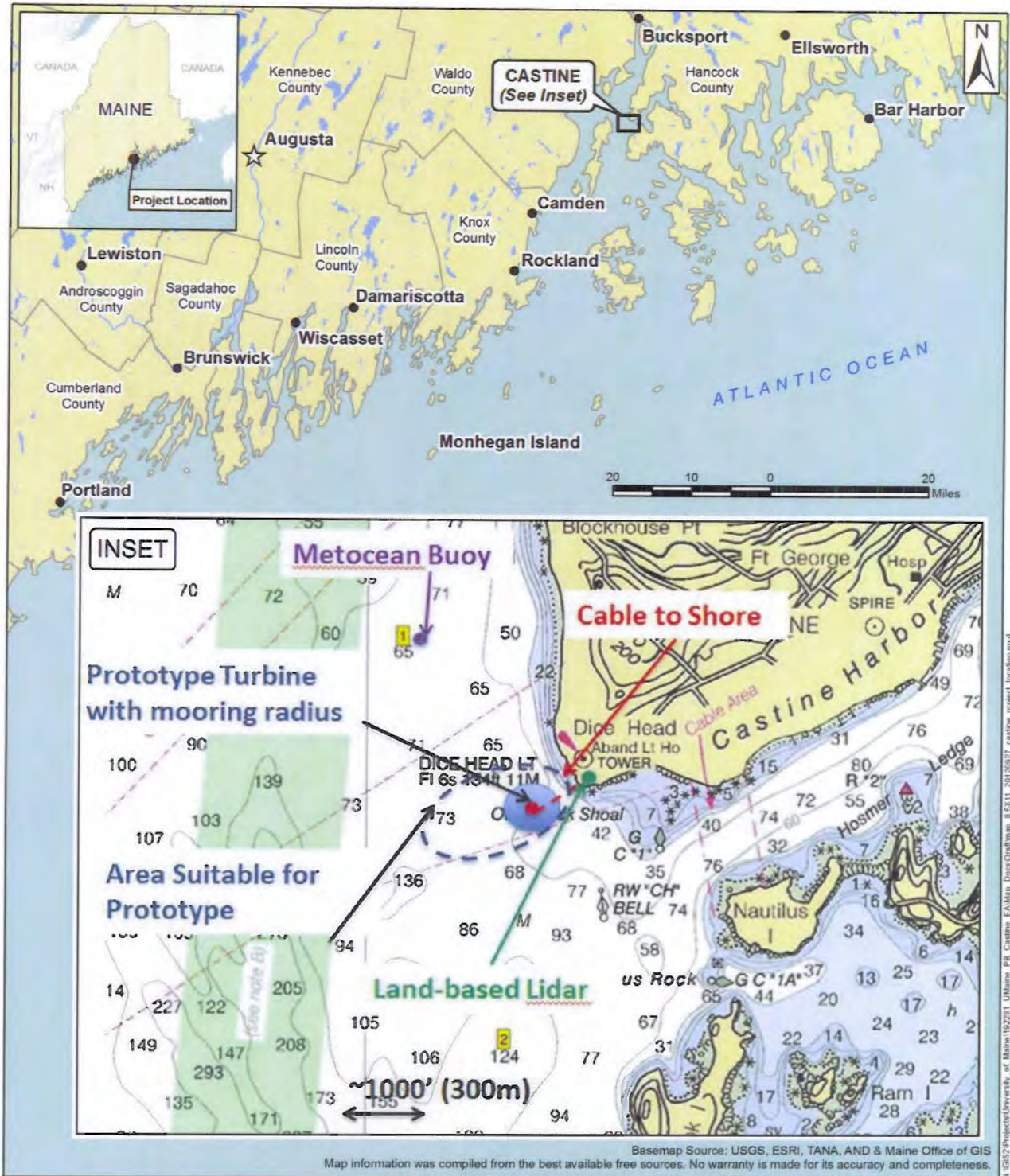
Sincerely,

A handwritten signature in black ink that reads "Laura Margason". The signature is written in a cursive, flowing style.

Laura Margason  
DOE NEPA Document Manager

Attached: Project Location Map

# Project Location of University of Maine Testing of a Floating Offshore Wind Turbine Platform, Castine, Maine





## Department of Energy

Golden Field Office  
1617 Cole Boulevard  
Golden, Colorado 80401-3393

November 2, 2012

Governor Reuben Clatyon Cleaves  
Passamaquoddy Tribe  
Pleasant Point Reservation  
P.O. Box 343  
Perry, ME 04667

**Subject: University of Maine Testing of a Floating Offshore Wind Turbine Platform, Castine, Maine**

To Governor Reuben Clatyon Cleaves:

The U.S. Department of Energy (DOE) is proposing to provide federal funding to the University of Maine (UMaine) to construct, deploy, and retrieve one small-scale floating turbine offshore of Maine. The objective of this project is to validate coupled aeroelastic/hydrodynamic computer models developed by the National Renewable Energy Laboratory and others for floating offshore wind turbines.

In September 2011 DOE completed an Environmental Assessment (EA) evaluating the potential effects of the University's plans to deploy two 1/3-scale wind turbines on floating platforms within the deepwater offshore wind test site in the Gulf of Maine near Monhegan Island. The University has since downscaled the size of their planned platform and turbine from 1/3 scale to 1/8 scale. Because of this change to a smaller size, for part of the year the platform and turbine would be deployed at a more sheltered nearshore location, near Castine Harbor, Maine (see attached figure).

The University proposes to deploy a 20 kilowatt power rated Renewegy wind turbine onto a moored floating platform. The platform would be located in an existing cableway in water that is 40 to 70 feet deep. The turbine would measure about 41 feet from the waterline to the hub, the rotor diameter would be about 32 feet, and the total height of the turbine above the water line would be up to about 57 feet. The platform would be moored with drag embedment anchors, which are similar to sailboat anchors, and catenary mooring lines. The turbine would be connected to the Central Maine Power grid via a cable to be temporarily installed about 500 to 1,000 feet along the seabed to shore. From just below the low tide line the cable would extend approximately 500 feet along the ground in a protective conduit to the point of interconnection at an existing power pole. The conduit would be removed at the end of the project.

The platform would be deployed for about four to five months, starting in the spring of 2013, and its performance would be monitored to study the design prior to deployment in the open ocean at Monhegan Island. During the deployment at Castine, the University would use sensors and telemetry systems installed on the platform to evaluate how it performs under varying wind and wave conditions. Environmental monitoring for birds, bats, marine mammals, benthic invertebrates, and fish would also take place post deployment. The University has already conducted pre-deployment environmental monitoring and data collection for birds, bats, marine



mammals, benthic invertebrates, and fish for this site to assist in determining affects to these resources.

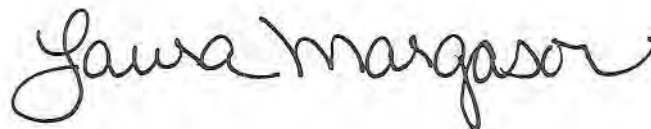
A Supplemental Environmental Assessment (EA) is currently being prepared for the proposed Castine site project by the Department's Golden Field Office to meet the requirements of the *National Environmental Policy Act*. DOE will include correspondence with your tribe in an appendix to the EA. The draft EA, when it is available, will be posted in the DOE Golden Field Office online reading room: [http://www.eere.energy.gov/golden/NEPA\\_DEA.aspx](http://www.eere.energy.gov/golden/NEPA_DEA.aspx). You will receive a notice of availability once the draft EA is posted. Please contact DOE if you would like to receive a hardcopy of the document.

Per the regulations of the Advisory Council on Historic Preservation at 36 CFR Section 800.2(c)(5), DOE is requesting information your tribe may have on properties of traditional religious and cultural significance within the vicinity of the proposed deployment near Castine Harbor and any comments or concerns you have on the potential for this proposed project to affect those properties. This information is being requested to aid in the preparation of that Environmental Assessment and to comply with the National Historic Preservation Act. If you have any such information, require additional information, have any questions or comments about that project or would like DOE to initiate formal consultation, please contact Ms. Laura Margason the Golden Field Office as soon as possible at the following:

Ms. Laura Margason  
U.S. Department of Energy  
1617 Cole Boulevard  
Golden, Colorado  
Email: [laura.margason@go.doe.gov](mailto:laura.margason@go.doe.gov)

Thank you in advance for your consideration.

Sincerely,

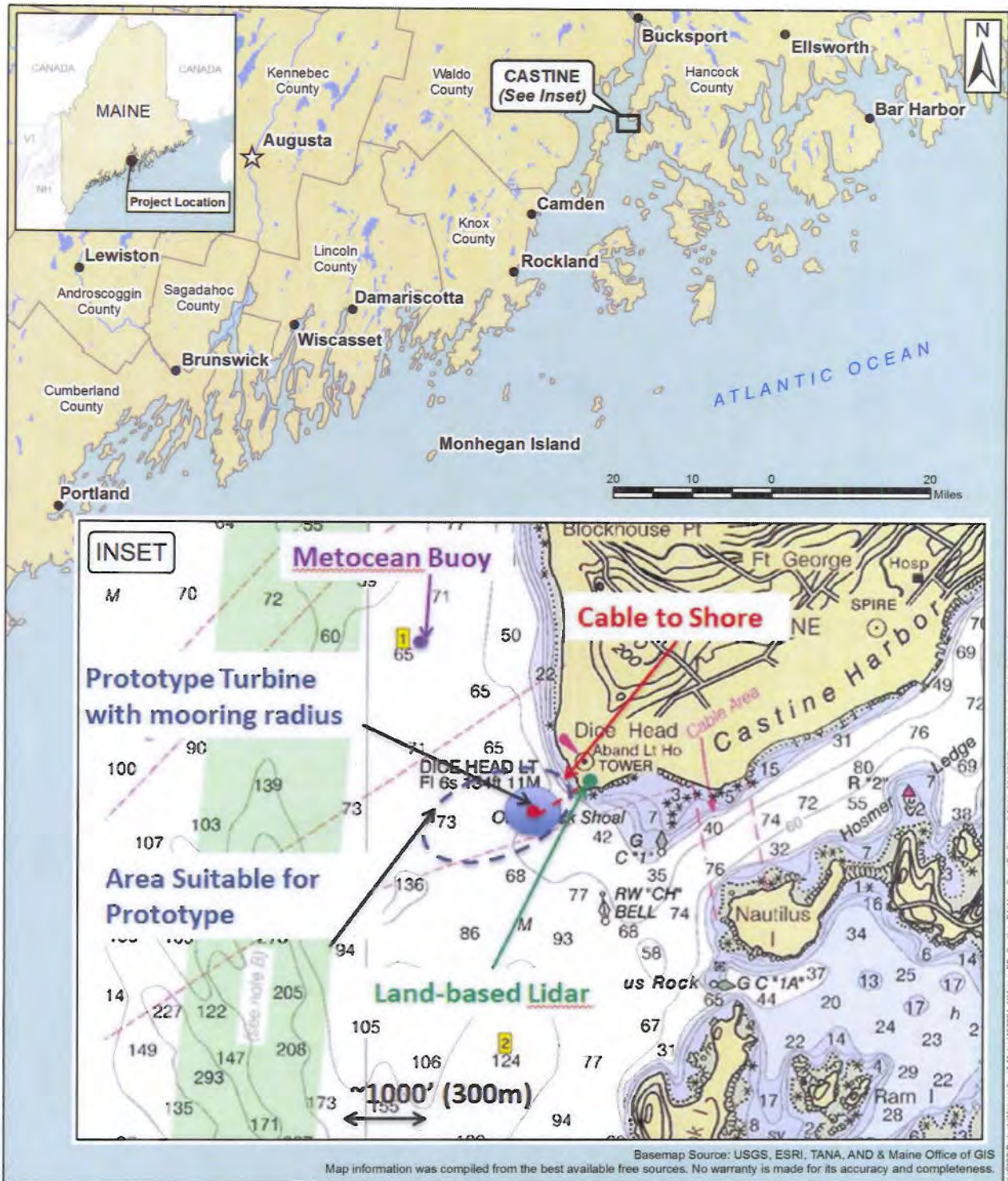
A handwritten signature in black ink that reads "Laura Margason". The signature is written in a cursive, flowing style.

Laura Margason  
DOE NEPA Document Manager

Attached: Project Location Map



# Project Location of University of Maine Testing of a Floating Offshore Wind Turbine Platform, Castine, Maine





## Department of Energy

Golden Field Office  
1617 Cole Boulevard  
Golden, Colorado 80401-3393

November 2, 2012

Chief Kirk Francis  
Penobscot Indian Nation  
12 Wabanaki Way  
Indian Island, ME 04468

**Subject: University of Maine Testing of a Floating Offshore Wind Turbine Platform, Castine, Maine**

To Chief Kirk Francis:

The U.S. Department of Energy (DOE) is proposing to provide federal funding to the University of Maine (UMaine) to construct, deploy, and retrieve one small-scale floating turbine offshore of Maine. The objective of this project is to validate coupled aeroelastic/hydrodynamic computer models developed by the National Renewable Energy Laboratory and others for floating offshore wind turbines.

In September 2011 DOE completed an Environmental Assessment (EA) evaluating the potential effects of the University's plans to deploy two 1/3-scale wind turbines on floating platforms within the deepwater offshore wind test site in the Gulf of Maine near Monhegan Island. The University has since downscaled the size of their planned platform and turbine from 1/3 scale to 1/8 scale. Because of this change to a smaller size, for part of the year the platform and turbine would be deployed at a more sheltered nearshore location, near Castine Harbor, Maine (see attached figure).

The University proposes to deploy a 20 kilowatt power rated Renewegy wind turbine onto a moored floating platform. The platform would be located in an existing cableway in water that is 40 to 70 feet deep. The turbine would measure about 41 feet from the waterline to the hub, the rotor diameter would be about 32 feet, and the total height of the turbine above the water line would be up to about 57 feet. The platform would be moored with drag embedment anchors, which are similar to sailboat anchors, and catenary mooring lines. The turbine would be connected to the Central Maine Power grid via a cable to be temporarily installed about 500 to 1,000 feet along the seabed to shore. From just below the low tide line the cable would extend approximately 500 feet along the ground in a protective conduit to the point of interconnection at an existing power pole. The conduit would be removed at the end of the project.

The platform would be deployed for about four to five months, starting in the spring of 2013, and its performance would be monitored to study the design prior to deployment in the open ocean at Monhegan Island. During the deployment at Castine, the University would use sensors and telemetry systems installed on the platform to evaluate how it performs under varying wind and wave conditions. Environmental monitoring for birds, bats, marine mammals, benthic invertebrates, and fish would also take place post deployment. The University has already conducted pre-deployment environmental monitoring and data collection for birds, bats, marine mammals, benthic invertebrates, and fish for this site to assist in determining affects to these



resources.

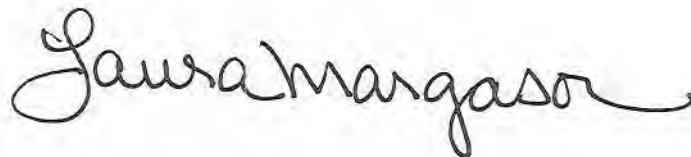
A Supplemental Environmental Assessment (EA) is currently being prepared for the proposed Castine site project by the Department's Golden Field Office to meet the requirements of the *National Environmental Policy Act*. DOE will include correspondence with your tribe in an appendix to the EA. The draft EA, when it is available, will be posted in the DOE Golden Field Office online reading room: [http://www.eere.energy.gov/golden/NEPA\\_DEA.aspx](http://www.eere.energy.gov/golden/NEPA_DEA.aspx). You will receive a notice of availability once the draft EA is posted. Please contact DOE if you would like to receive a hardcopy of the document.

Per the regulations of the Advisory Council on Historic Preservation at 36 CFR Section 800.2(c)(5), DOE is requesting information your tribe may have on properties of traditional religious and cultural significance within the vicinity of the proposed deployment near Castine Harbor and any comments or concerns you have on the potential for this proposed project to affect those properties. This information is being requested to aid in the preparation of that Environmental Assessment and to comply with the National Historic Preservation Act. If you have any such information, require additional information, have any questions or comments about that project or would like DOE to initiate formal consultation, please contact Ms. Laura Margason the Golden Field Office as soon as possible at the following:

Ms. Laura Margason  
U.S. Department of Energy  
1617 Cole Boulevard  
Golden, Colorado  
Email: [laura.margason@go.doe.gov](mailto:laura.margason@go.doe.gov)

Thank you in advance for your consideration.

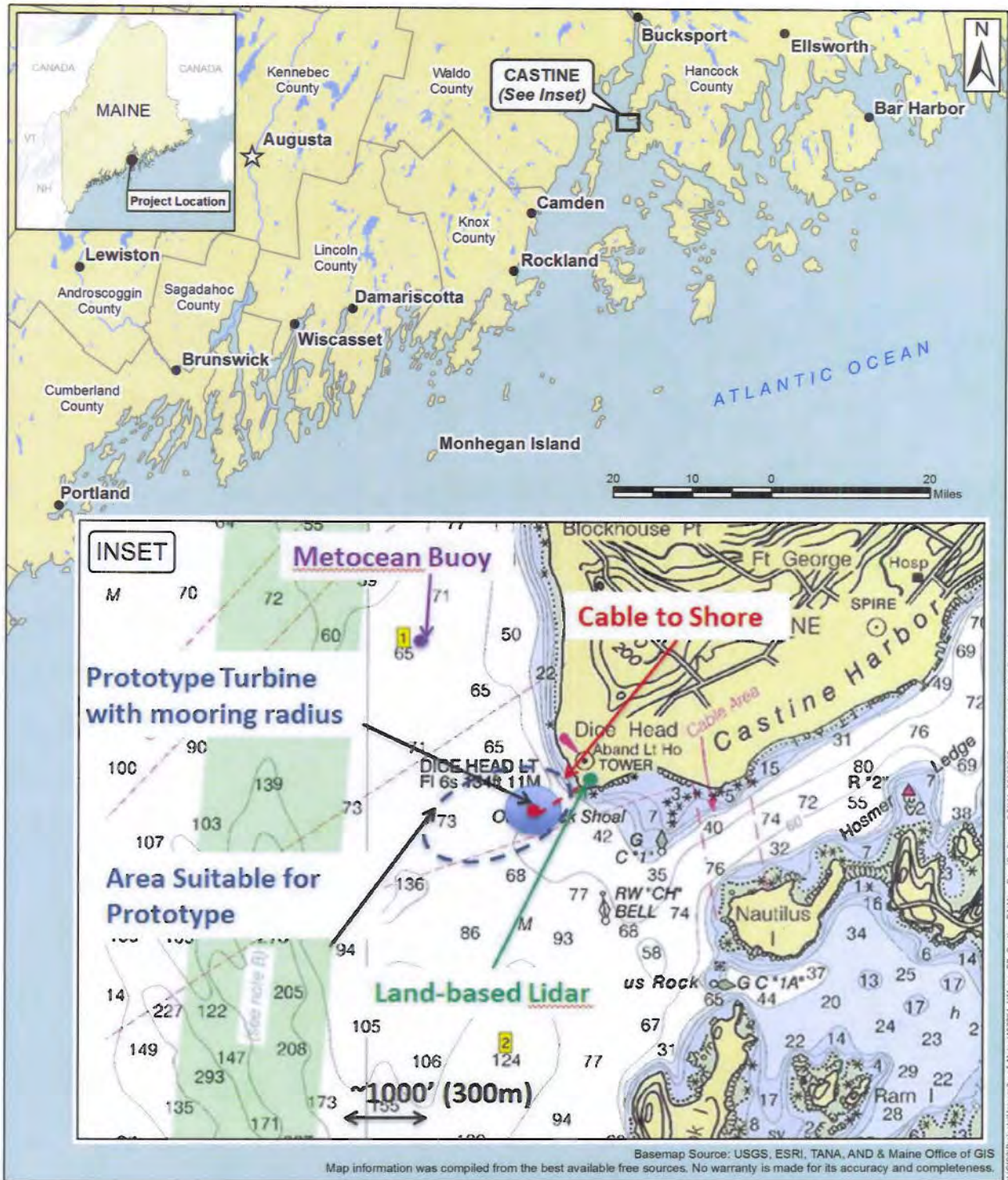
Sincerely,

A handwritten signature in black ink that reads "Laura Margason". The signature is written in a cursive, flowing style.

Laura Margason  
DOE NEPA Document Manager

Attached: Project Location Map

## Project Location of University of Maine Testing of a Floating Offshore Wind Turbine Platform, Castine, Maine





## Department of Energy

Golden Field Office  
1617 Cole Boulevard  
Golden, Colorado 80401-3393

November 2, 2012

Chief Joseph Socobasin  
Passamaquoddy Tribe  
Indian Township  
P.O. Box 301  
Princeton, ME 04668

**Subject: University of Maine Testing of a Floating Offshore Wind Turbine Platform, Castine, Maine**

To Chief Joseph Socobasin:

The U.S. Department of Energy (DOE) is proposing to provide federal funding to the University of Maine (UMaine) to construct, deploy, and retrieve one small-scale floating turbine offshore of Maine. The objective of this project is to validate coupled aeroelastic/hydrodynamic computer models developed by the National Renewable Energy Laboratory and others for floating offshore wind turbines.

In September 2011 DOE completed an Environmental Assessment (EA) evaluating the potential effects of the University's plans to deploy two 1/3-scale wind turbines on floating platforms within the deepwater offshore wind test site in the Gulf of Maine near Monhegan Island. The University has since downscaled the size of their planned platform and turbine from 1/3 scale to 1/8 scale. Because of this change to a smaller size, for part of the year the platform and turbine would be deployed at a more sheltered nearshore location, near Castine Harbor, Maine (see attached figure).

The University proposes to deploy a 20 kilowatt power rated Renewegy wind turbine onto a moored floating platform. The platform would be located in an existing cableway in water that is 40 to 70 feet deep. The turbine would measure about 41 feet from the waterline to the hub, the rotor diameter would be about 32 feet, and the total height of the turbine above the water line would be up to about 57 feet. The platform would be moored with drag embedment anchors, which are similar to sailboat anchors, and catenary mooring lines. The turbine would be connected to the Central Maine Power grid via a cable to be temporarily installed about 500 to 1,000 feet along the seabed to shore. From just below the low tide line the cable would extend approximately 500 feet along the ground in a protective conduit to the point of interconnection at an existing power pole. The conduit would be removed at the end of the project.

The platform would be deployed for about four to five months, starting in the spring of 2013, and its performance would be monitored to study the design prior to deployment in the open ocean at Monhegan Island. During the deployment at Castine, the University would use sensors and telemetry systems installed on the platform to evaluate how it performs under varying wind and wave conditions. Environmental monitoring for birds, bats, marine mammals, benthic invertebrates, and fish would also take place post deployment. The University has already conducted pre-deployment environmental monitoring and data collection for birds, bats, marine



mammals, benthic invertebrates, and fish for this site to assist in determining affects to these resources.

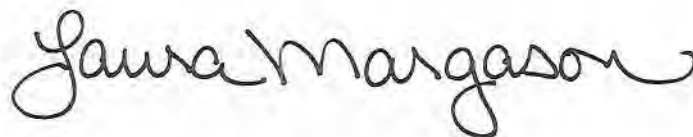
A Supplemental Environmental Assessment (EA) is currently being prepared for the proposed Castine site project by the Department's Golden Field Office to meet the requirements of the *National Environmental Policy Act*. DOE will include correspondence with your tribe in an appendix to the EA. The draft EA, when it is available, will be posted in the DOE Golden Field Office online reading room: [http://www.eere.energy.gov/golden/NEPA\\_DEA.aspx](http://www.eere.energy.gov/golden/NEPA_DEA.aspx). You will receive a notice of availability once the draft EA is posted. Please contact DOE if you would like to receive a hardcopy of the document.

Per the regulations of the Advisory Council on Historic Preservation at 36 CFR Section 800.2(c)(5), DOE is requesting information your tribe may have on properties of traditional religious and cultural significance within the vicinity of the proposed deployment near Castine Harbor and any comments or concerns you have on the potential for this proposed project to affect those properties. This information is being requested to aid in the preparation of that Environmental Assessment and to comply with the National Historic Preservation Act. If you have any such information, require additional information, have any questions or comments about that project or would like DOE to initiate formal consultation, please contact Ms. Laura Margason the Golden Field Office as soon as possible at the following:

Ms. Laura Margason  
U.S. Department of Energy  
1617 Cole Boulevard  
Golden, Colorado  
Email: [laura.margason@go.doe.gov](mailto:laura.margason@go.doe.gov)

Thank you in advance for your consideration.

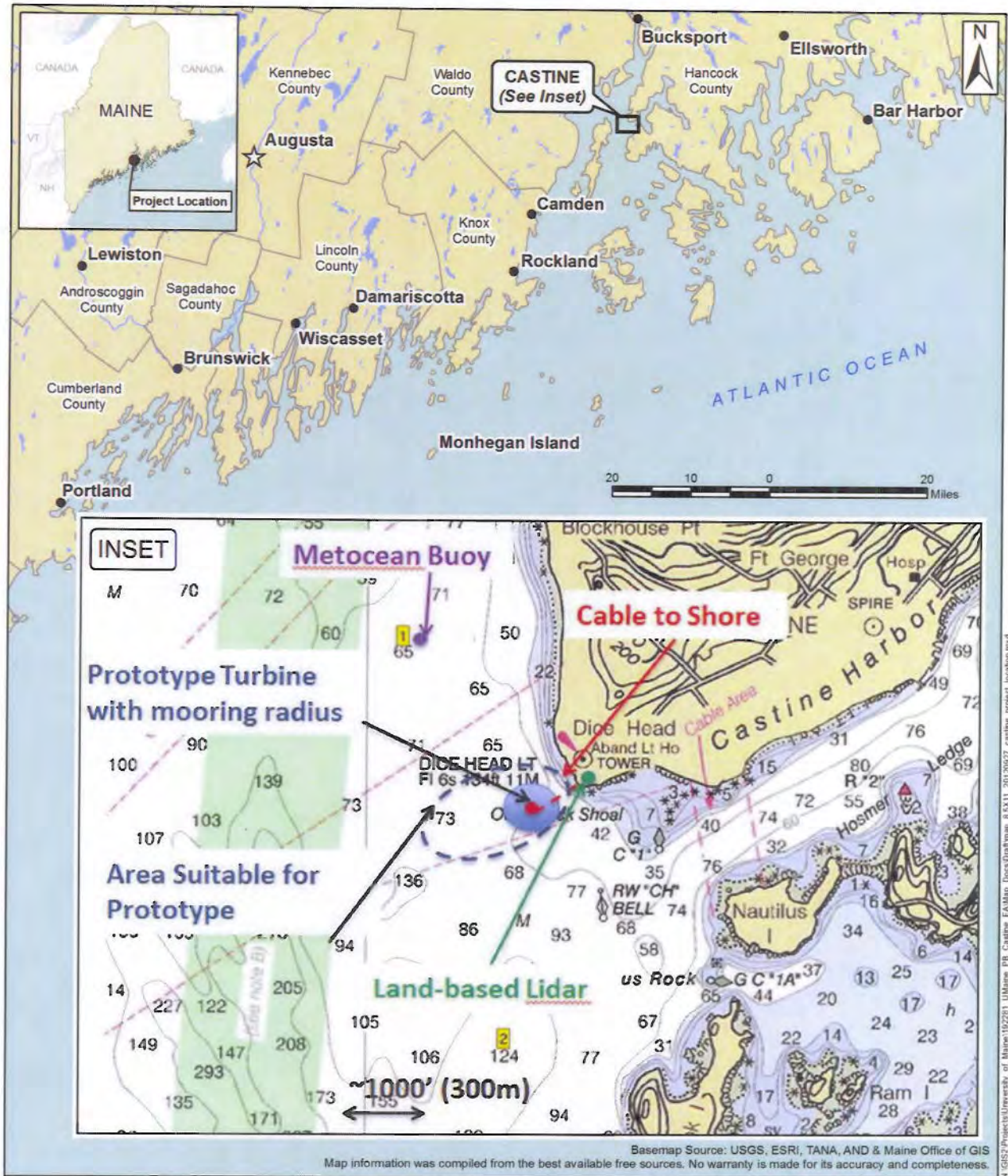
Sincerely,

A handwritten signature in black ink that reads "Laura Margason". The signature is written in a cursive, flowing style.

Laura Margason  
DOE NEPA Document Manager

Attached: Project Location Map

# Project Location of University of Maine Testing of a Floating Offshore Wind Turbine Platform, Castine, Maine





UNITED STATES DEPARTMENT OF COMMERCE  
National Oceanic and Atmospheric Administration  
NATIONAL MARINE FISHERIES SERVICE  
NORTHEAST REGION  
55 Great Republic Drive  
Gloucester, MA 01930-2276

NOV 16 2012

Laura Margason  
Department of Energy  
Golden Field Office  
1617 Cole Boulevard  
Golden, Colorado 80401-3393

RE: University of Maine Interim Offshore Wind Test Site Castine, Maine

Dear Ms. Margason,

Your October 18, 2012, letter, requests updated information on NOAA trust resources near the University of Maine's proposed interim offshore wind test site off Castine Harbor in Maine. Below, we provide updated Essential Fish Habitat (EFH), Endangered Species Act (ESA), and Marine Mammal Protection Act (MMPA) information.

*NMFS listed ESA species*

Several species of fish listed under our jurisdiction occur in the Gulf of Maine and the project area. The Federally endangered Gulf of Maine Distinct Population Segment (GOM DPS) of Atlantic salmon (*Salmo salar*) occurs in the action area. The GOM DPS includes all anadromous Atlantic salmon whose freshwater range occurs in the watersheds from the Androscoggin River northward along the Maine coast to the Dennys River. Included in the DPS are all associated conservation hatchery populations used to supplement these natural populations. Currently, such conservation hatchery populations are maintained at Green Lake National Fish Hatchery (GLNFH) and Craig Brook National Fish Hatchery (CBNFH). This project is located within the range of the GOM DPS of Atlantic salmon.

Federally endangered shortnose sturgeon (*Acipenser brevirostrum*) occur in the action area. Additionally, endangered New York Bight (NYB) and threatened Gulf of Maine (GOM) Distinct Population Segments (DPSs) of Atlantic sturgeon (*Acipenser oxyrinchus oxyrinchus*) occur in the action area. Most Atlantic sturgeon in the action area are likely to be GOM DPS origin. However, some Atlantic sturgeon occurring in the action area are of Canadian origin (and therefore, not listed under the ESA) and a small portion of Atlantic sturgeon occurring in the action area are likely to be NYB origin. Sub-adult and adult Atlantic and shortnose sturgeon are most likely to be present in the action area during warmer months while participating in coastal migrations and while foraging.

Several species of listed whales and sea turtles occur seasonally in the waters off of Maine. North Atlantic right whales (*Eubalaena glacialis*) are present in the Gulf of Maine year-round, however, sightings are uncommon in nearshore waters such as Castine Harbor. Humpback





whales (*Megaptera novaeangliae*) feed during the spring, summer, and fall over a range that encompasses the eastern coast of the United States, including waters off the coast of Maine. Fin (*Balaenoptera physalus*), sei (*Balaenoptera borealis*) and sperm (*Physeter macrocephalus*) whales are also seasonally present in New England waters but are typically found in deeper offshore waters and are not likely to occur in the action area.

Federally endangered leatherback (*Dermochelys coriacea*) and threatened loggerhead (*Caretta caretta*) sea turtles may also occur seasonally in the action area. These species are typically present in New England waters from June through October. While Kemp's ridley (*Lepidochelys kempi*) and green sea turtles (*Chelonia mydas*) also occur seasonally in New England waters, occurrence in the action area would be extremely rare.

#### *Critical habitat*

Critical habitat has been designated for listed Atlantic salmon pursuant to Section 4(b)(2) of the ESA. The critical habitat designation for the GOM DPS includes 45 specific areas occupied by Atlantic salmon at the time of listing that include approximately 19,571 km of perennial river, stream, and estuary habitat and 799 square km of lake habitat within the range of the GOM DPS which include those physical and biological features essential to the conservation of the species. The entire occupied range of the GOM DPS in which critical habitat is designated is within the State of Maine. Castine Harbor is not located within designated critical habitat for the Atlantic salmon GOM DPS. There is no other critical habitat designated by NMFS in Maine.

#### *ESA Section 7 Consultation*

Section 7(a)(2) of the ESA, states that each Federal agency shall, in consultation with the Secretary, ensure that any action they authorize, fund, or carry out is not likely to jeopardize the continued existence of a listed species or result in the destruction or adverse modification of designated critical habitat. Any discretionary federal action that may affect a listed species must undergo Section 7 consultation. It is our understanding that depending on project siting, authorizations or permits may be required from the U.S. Army Corps of Engineers (USACE) and/or the Bureau of Ocean Energy Management (BOEM). We encourage you and the applicant to work with the ACOE and/or BOEM to initiate section 7 consultation as appropriate. We recommend that you complete any necessary consultation with us prior to issuing any final permits or authorizations. We also request that you identify a lead Federal agency for purposes of section 7 consultation and that your determination be provided to us in writing in a letter that identifies all of the federal authorizations or permits necessary for the project.

#### *Marine Mammal Protection Act*

All marine mammals listed under the ESA are also protected under the MMPA. In addition, other non-ESA listed marine mammal species may occur near Castine Harbor. Minke whales (*Balaenoptera acutorostrata*) are common in New England waters during spring and summer when their distributions are widespread. Minke whales are also present in New England waters during the fall at reduced levels and generally absent during winter months. In addition, based on information from stranding records, we know that grey seal (*Halichoerus grypus*), harbor seal (*Phoca vitulina*), Atlantic white-sided dolphin (*Lagernorhynchus acutus*), common dolphin (*Delphinus delphis*), short- and long- finned pilot whales (*Globicephala macrohynchus* and *G.*

*melas*) and Kogia (pygmy sperm whale) (*Kogia breviceps*) are also found in Maine coastal waters. If it is determined the project or alterations to the project technology could impact marine mammals the applicant needs to apply for an incidental take authorization pursuant to section 101 (a)(5)(A-D) of the MMPA. More information on the MMPA permitting program is available at: <http://www.nmfs.noaa.gov/pr/permits/incidental.htm>. You can also contact the Office of Protected Resources' Permits and Conservation Division in Silver Spring, Maryland at (301) 427-8400.

#### *Essential Fish Habitat and Other Fishery Habitats*

As noted in your letter, the proposed offshore wind test site in Castine Harbor, Maine, has been identified as EFH for federally-managed species. We concur that the adverse effects on EFH and other National Oceanic and Atmospheric Administration (NOAA) trust resources from the proposed project may be minimal. However, because some adverse effects on fishery habitats may result from anchoring and from the power cable, you should consult with us under the Magnuson-Stevens Fishery Conservation and Management Act (MSA) and the Fish and Wildlife Coordination Act (FWCA). The EFH regulations (50 CFR§600.905) guide the consultation requirements for EFH. The regulations mandate the preparation of EFH assessments and generally outlines each agency's obligations in this consultation procedure. An EFH Assessment should include at a minimum the following information:

- 1) a description of the proposed action;
- 2) an analysis of reasonably foreseeable impacts including secondary and cumulative effects on EFH, Federally-managed species and major prey species;
- 3) the action agencies views regarding the effects on EFH; and,
- 4) proposed mitigation, as appropriate.

Table 1 in your letter correctly lists the species and life history stages of EFH in the project area. Additional information on individual species' and life stage requirements can be found in a series of source documents published by NOAA's Northeast Fisheries Science Center and are available at the following website: <http://nefsc.noaa.gov/publications/tm/>.

In addition, a number of NOAA-trust resources will require consultation under the FWCA. The FWCA requires that Federal agencies consult with us for projects that may modify a water body. Because the waters in the vicinity of Castine, Maine, support populations of diadromous species, including blueback herring, alewife, rainbow smelt, striped bass, American eel, and American shad, the DOE should also consider the effects of the proposed project on these species. Diadromous fishery resources serve as prey for a number of federally-managed species and several species are considered a component of EFH pursuant to the MSA.

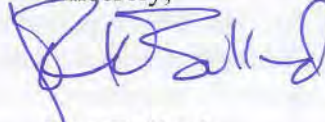
As noted above, there is a potential for adverse impacts on benthic habitats resulting from anchors, anchor lines, and the power cable during construction and operation of the test facility. We previously recommended, in our letter dated August 16, 2011, that a monitoring plan be developed to include an assessment of benthic impacts resulting from anchor placement and configuration (i.e., anchor line scour) as well as to assess recovery of benthic habitats once the mooring system is removed. We continue to recommend that a monitoring plan be developed for

the site in Castine Harbor, Maine, for potential anchor-related scour and power cable impacts. The monitoring plan should be appropriately designed to identify benthic impacts occurring during construction and operation of the facility.

*Conclusions*

Thank you for the opportunity to provide these comments on the proposed offshore wind test site off Castine Harbor, Maine. Should you have any questions regarding EFH and FWCA consultations, please contact Michael Johnson in our Habitat Conservation Division (Mike.R.Johnson@noaa.gov or (978) 281-9130). Please address questions related to the MMPA and any associated permitting to Michelle Magliocca in the Office of Protected Resources (Michelle.Magliocca@noaa.gov or (301)427-8426). Should you have any ESA related questions, please contact David Bean in our Maine Field Office (David.Bean@noaa.gov or (207) 866-4172).

Sincerely,



John Bullard  
Northeast Regional Administrator

Cc: Johnson, Boelke – F/NER4  
Bean – F/NER3  
Magliocca – F/PR1

PRD Filing Code: Sec 7 tech assist - Dept. Energy: UMaine wind test site



**AROOSTOOK BAND OF MICMACS**

7 NORTHERN ROAD  
PRESQUE ISLE, MAINE 04769  
(207) 764-1972

November 29, 2012

Laura Margason  
US Department of Energy  
1617 Cole Boulevard  
Golden Colorado 80401-3393

RE: Floating Offshore Wind Turbine Platform  
Applicant: University of Maine  
Municipality: Castine, Maine

Dear Laura Margason,  
Thank you for the opportunity to review the above-referenced project for compliance with National Environmental Policy Act (NEPA) and National Historic Preservation Act (NHPA) requirements.

Based on the project description, we do not have knowledge of any specific sites or cultural features that exist at the proposed project location. However, this geographic area does constitute traditional areas that were historically utilized by members of the Aroostook Band of Micmacs and other northeaster Tribes. Therefore, we respectfully, request that if during the course of excavation/construction activities, human remains, artifacts, or any other evidence of Native American presence is discovered, that site activities in the vicinity of the discovery immediately cease, pending notification to us.

In addition, if this project results in wetland disturbances requiring mitigation, we are requesting that you utilize the black ash (*Fraginus nigra*) as the principle wetland species for wetland restoration activities. The black ash tree has special significance in the culture of the northeastern Tribes and is used extensively for weaving baskets and other Native American crafts. The black ash tree also provides valuable food and habitat for migratory waterfowl and other wildlife. Unfortunately however, this species has been selected against by foresters and landowners who favor other tree species. As a result of this, and other environmental factors, the black ash tree is in serious decline in Maine. The Aroostook Band of Micmacs has completed several black ash wetland restoration

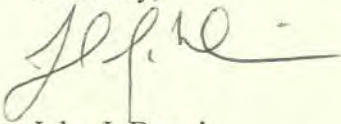


projects and we have a dependable source for highly-quality seedlings, and the experience and expertise to assist you with black ash wetland restoration projects.

On the subject of human remains, artifacts, or any other evidence of Native American presence is discovered. The human remains will be reburied with the appropriate respect for the remains that is required at a distinctive and respectable site. The artifacts and other evidence of Native American discovery will be documented with appropriate detail. The items will be analyzed for the precise period of the items distinctive period and will be documented by the Tribal Historic Preservation Officer from the Aroostook Band of Micmacs.

If you have any questions or comments, please feel free to contact me at (207) 764-1972.

Sincerely,



John J. Dennis  
Cultural Director / Tribal Historic Preservation Officer Designee

cc: Richard Getchell  
Chief of the Aroostook Band of Micmacs





**PENOBSCOT INDIAN NATION  
CULTURAL & HISTORIC PRESERVATION DEPARTMENT  
CHRIS SOCKALEXIS – TRIBAL HISTORIC PRESERVATION OFFICER  
12 WABANAKI WAY, INDIAN ISLAND, ME 04468  
E-MAIL: [Chris.Sockalexis@penobscotnation.org](mailto:Chris.Sockalexis@penobscotnation.org) FAX: 207-817-7450**

<b>NAME</b>	Laura Margason
<b>ADDRESS</b>	US Department of Energy 1617 Cole Boulevard Golden, CO 80401-3393
<b>OWNER'S NAME</b>	University of Maine
<b>TELEPHONE</b>	
<b>FAX</b>	
<b>EMAIL</b>	<a href="mailto:laura.margason@go.doe.gov">laura.margason@go.doe.gov</a>
<b>PROJECT NAME</b>	Floating offshore wind turbine platform
<b>PROJECT SITE</b>	Castine, ME
<b>DATE OF REQUEST</b>	November 2, 2012
<b>DATE REVIEWED</b>	November 29, 2012

Thank you for the opportunity to comment on the above referenced project. This project appears to have no impact on a structure or site of historic, architectural or archaeological significance to the Penobscot Nation as defined by the National Historic Preservation Act of 1966, and subsequent updates.

Also, if Native American cultural materials are encountered during the course of the project, please contact me at (207) 817-7471. Thank you.

**CHRIS SOCKALEXIS, THPO**  
Penobscot Nation



**Department of Energy**  
Golden Field Office  
1617 Cole Boulevard  
Golden, Colorado 80401-3393

Earle G. Shettleworth, Jr., Director,  
Maine Historic Preservation Commission  
55 Capitol Street, 65 State House Station  
Augusta, ME, 04333-0065

Dear Mr. Shettleworth:

**Subject: University of Maine Testing of a Floating Offshore Wind Turbine Platform, Castine, Maine**

The U.S. Department of Energy (DOE) is proposing to award federal funding to the University of Maine to construct, deploy, and retrieve one small-scale floating turbine offshore of Maine. In September 2011, DOE completed an Environmental Assessment (EA) that evaluated the potential effects resulting from the University's plans to deploy two 1/3-scale wind turbines on floating platforms within the deepwater offshore wind test site in the Gulf of Maine near Monhegan Island. In a letter to DOE dated April 29, 2011, your office concurred with DOE's finding that the Monhegan project would have no adverse effect on historic properties, as defined by Section 106 of the National Historic Preservation Act.

The University has since downscaled the size of their planned platform and turbine from 1/3 scale to 1/8 scale and plans to install one turbine, not two. Because of the change to a smaller size, for part of the year the platform and turbine would be deployed at a more sheltered nearshore location, near Castine Harbor, Maine (see attached figure). The project would be deployed for three to four months this spring/summer season (the University anticipates late March or April, of 2013) where its performance would be monitored to study the design prior to deployment into the open ocean at Monhegan Island.

The University proposes to deploy a Renewegy wind turbine with a power rating of 20 kilowatts onto a floating platform. The platform would be located in an existing cableway in water that is about 100 feet deep. The turbine would measure about 41 feet from the waterline to the hub, the rotor diameter would be about 32 feet, and the total height of the turbine above the water line would be up to about 57 feet. The platform would be moored with drag embedment anchors or gravity anchors, and catenary mooring lines. The turbine would be connected to the Central Maine Power grid via a cable that would be temporarily installed about 500 to 1,000 feet along

the seabed to shore. On shore, the cable would be positioned along the ground for 300 feet and cross one residential property, for which landowner permission has been granted.

DOE understands that the University has had several preliminary discussions with your staff regarding this project. To comply with obligations under Section 106 of the National Historic Preservation Act, DOE has defined the area of potential effects to historic properties based on two components. First, the area of the seabed that would be directly disturbed by deployment of anchors is included to account for the potential direct effects of the project on shipwrecks. Second, the area of the Castine peninsula from which the platform and turbine could be visible is included to address indirect impacts from a change in the viewshed from historic properties.

To identify historic properties in the area of potential effects, the University has reviewed the National Historic Register, conducted a dive survey and magnetometer survey, and has discussed the project with the Castine Historic Society. DOE has reached out to five Maine tribes that may have historic ties to the area. The Penobscot Indian Nation and the Aroostook Band of Micmacs, both in transmittals dated November 29, 2012, indicated that the project would not affect any sites of tribal significance. The remaining tribes have not responded to the consultation request or identified any concerns.

There are numerous historic markers in Castine, and the National Historic Register lists three historic or archeological districts and four historic properties in Castine:

- Castine Historic District,
- Pentagoet Archeological District,
- Off-the-Neck Historic District,
- Fort George,
- *Bowdoin* (schooner),
- Cate House, and
- John Perkins House.

The Castine Historic District was added to the National Register of Historic Places in 1973, and includes the peninsula of Castine (referred to as On-neck Castine). The Pentagoet Archeological District is the site of a trading post built by the French during the 17th century located on the shore of Castine Harbor (National Historic Landmarks Program 2012). The Off-the-Neck Historic District is located north of the Castine peninsula, facing the Bagaduce River, and contains a number of dwellings, many in the Federal style of architecture (Downeast and Acadia 2012). Fort George is an earthworks fort built by the British in 1779 during the American Revolutionary War. It has been partially restored as a state memorial. The *Bowdoin* is a historic ship built in 1921 for Arctic exploration and owned by Maine Maritime Academy. Cate House and Perkins House both located in the Village of Castine, are historic colonial residences (National Historic Register 2012). Also, Dyce Head Lighthouse is listed in the inventory of historic light stations and is included in the Castine Historical District. The Town of Castine also



has established an historic district, which consists of the downtown area of Castine. That local historic district and is on the opposite side of the peninsula from the proposed turbine location (Town of Castine 2011).

The turbine platform would be located in a previously disturbed cable ROW to minimize the risk of disturbing shipwrecks or other underwater cultural and natural resources. No known shipwrecks have occurred in the project area and no signs of shipwrecks were observed during the University's diver surveys conducted at the site in 2012. As directed by the Maine SHPO, the University staff consulted with Dr. Warren Riess, a marine archaeology professor at the University, to further evaluate whether any Penobscot Expedition shipwrecks or other related historic resource concerns could be located in the project area (Pers. comm. R. Reed, Maine SHPO with D. Brady, University of Maine, October 18, 2012). In correspondence with SHPO staff, Dr. Riess stated "...that all of the known and assumed locations of the Penobscot Expedition vessel remains are well north of the proposed site. The only exception is the privateer *Defence*, which is miles west of Castine", (Pers. comm. Dr. W. Riess, University of Maine with R. Reed, Maine SHPO, October 19, 2012).

Dr. Riess oversaw a magnetometer survey of the proposed project site on December 10, 2012, and survey results confirmed that there are no shipwrecks at the site. Results of that survey were submitted to your office by Dr. Riess on December 12.

The University would locate the turbine off of the western shore of the Castine peninsula in part to minimize its visibility from historic properties. As such, it would not be visible from the Off-the-Neck Historic District or most occupied areas on the peninsula, including much of the Village of Castine, such as where the Cate and Perkins houses and the Pentagoet Archeological District are located and the schooner *Bowdoin* is docked. The closest historic property to the proposed turbine location is the Dyce Head lighthouse, which is accessible to the public. The turbine would not be visible to the public from that lighthouse or from some other areas on the western side of the peninsula because of the steep shoreline and dense vegetation located there (see attached photograph). However, the turbine might be visible from some areas along the western portion of the Castine Historic District and from some of the higher points on the peninsula. There might also be some properties from which the turbine could be viewed that are eligible for listing under the National Register of Historic Places. Because the 1/8-scale turbine would have a maximum height of 57 feet above the waterline, it would appear small from any location within the Castine Historic District or elsewhere on the peninsula. In emails to SHPO dated November 16, 2012, the Town Manager stated, regarding the Town of Castine historic district, that "the turbine site is approximately 1 mile from the closest boundary of our historic district and can't be seen from the district", and the Chair of the Castine Historic Preservation Commission stated that they "...do not feel there is any impact to the Historic District viewscape" (Emails dated November 16, 2012 from Jimmy Goodson, Chair of Historic Preservation Commission and Dale Abernethy, Town Manager, to Robin Reed, SHPO). Finally, because the turbine would be deployed for less than four months, any change in the view from an

historic property would be temporary. Therefore, the turbine and platform would not dominate or otherwise substantially change the view from historic properties in a way that would diminish the integrity of the properties' significant historic features.

Based on this analysis, DOE finds that there would be no direct adverse effect to underwater historic properties from deployment and retrieval of the floating platform or indirect adverse effects to the viewshed from historic properties on the Castine peninsula, and we request your input and/or concurrence with this conclusion.

DOE is in the process of developing a Supplemental EA to cover these activities off of Castine. A notification will be sent to your office when the Draft Supplemental EA is available for public review.

If you have any questions, please contact me at 720-356-1322 or via my email at [Laura.Margason@go.doe.gov](mailto:Laura.Margason@go.doe.gov).

Sincerely,



Laura Margason  
NEPA Document Manager

Attachments (map and photograph)

References:

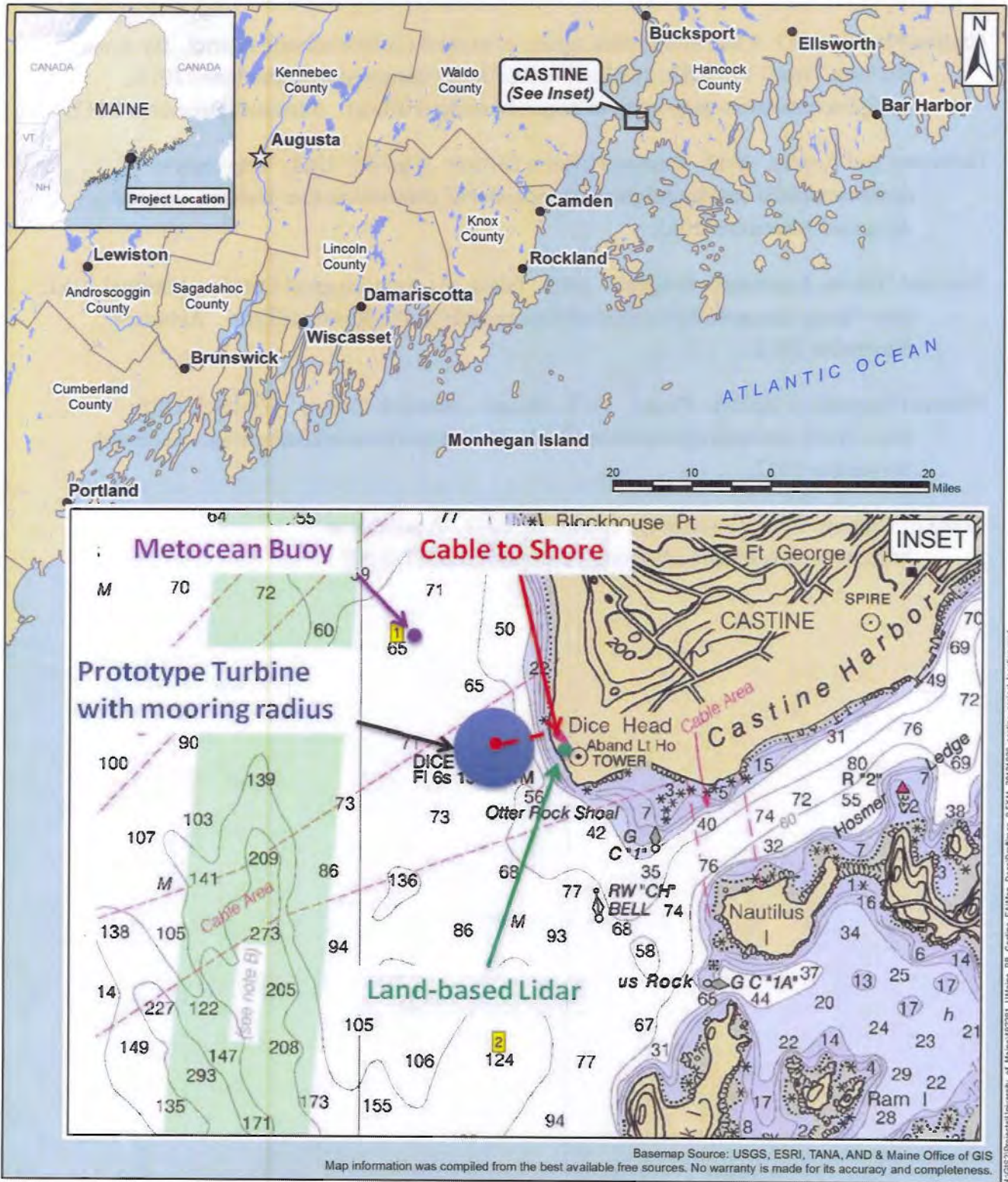
Castine Patriot. 2012. Commission tries, again, to expand Castine historic district. By Anne Berleant. April 12, 2012. [Online] URL: <http://castinepatriot.com/news/2012/apr/12/commission-tries-again-to-expand-castine-historic/>. Accessed December 2012.

Downeast and Acadia. 2012. Castine Historic District. [Online] URL: [http://www.downeastacadia.com/highlights/history/historic\\_districts/castine\\_historic\\_district/](http://www.downeastacadia.com/highlights/history/historic_districts/castine_historic_district/). Accessed November 2012.

National Historic Landmarks Program. 2012. Pentagoet Archeological District. [Online] URL: <http://tps.cr.nps.gov/nhl/detail.cfm?ResourceId=2148&ResourceType> . Accessed November 2012.

National Register of Historic Places. 2012. Maine – Hancock County. [Online] URL: <http://www.nationalregisterofhistoricplaces.com/me/Hancock/state.html>. Accessed November 2012.

Town of Castine. 2011. Zone Map. March 26, 2011. Available at <http://www.castine.me.us/Zoning%20Map%202011-2.pdf>.





**VIEW FROM THE BASE OF THE DYCE HEAD LIGHTHOUSE TOWARD THE SHORE.**



MAINE HISTORIC PRESERVATION COMMISSION  
 55 CAPITOL STREET  
 65 STATE HOUSE STATION  
 AUGUSTA, MAINE  
 04333

PAUL R. LEPAGE  
 GOVERNOR

EARLE G. SHETTLEWORTH, JR.  
 DIRECTOR

January 2, 2013

Mr. Andrew D. Qua  
 Kleinschmidt  
 P.O. Box 650  
 Pittsfield, ME 04967

Project: MHPC# 1539-12 - University of Maine deepwater offshore floating wind turbine testing and demonstration project: Castine Harbor  
 Town: Castine, ME

Dear Mr. Qua:

In response to your recent request, I have reviewed the information received December 12 and 20, 2012 to continue consultation on the above referenced project in accordance with Section 106 of the National Historic Preservation Act of 1966, as amended (NHPA).

Based on the information submitted, I have concluded that the proposed undertaking will have **no adverse effect** on historic properties, as defined by Section 106 of the National Historic Preservation Act.

However, our concurrence is conditional upon the following understanding: This deployment of the floating wind turbine off of the shore of Castine will be a temporary installation only.

Please contact Robin Reed of my staff if we can be of further assistance in this matter.

Sincerely,

Kirk F. Mohny  
 Deputy State Historic Preservation Officer

cc. Laura Margason, U.S. Department of Energy  
 Dr. Damian Brady, University of Maine  
 Dr. Warren Riess, University of Maine  
 Dale Abernathy, Town of Castine



**Department of Energy**  
Golden Field Office  
1617 Cole Boulevard  
Golden, Colorado 80401-3393

January 16, 2013

Mr. John Bullard  
Assistant Regional Administrator for Protected Resources  
National Marine Fisheries Service, Northeast Region  
55 Great Republic Drive  
Gloucester, MA 01930

**Subject: Section 7 Endangered Species Act, Magnuson-Stevens Fishery Conservation and Management Act, Marine Mammal Protection Act, and Fish and Wildlife Coordination Act Consultation for the University of Maine Testing of a Floating Offshore Wind Turbine Platform, Castine, Maine**

Dear Mr. Bullard:

The U.S. Department of Energy (DOE) is requesting concurrence from the National Marine Fisheries Service (NMFS) that the proposed University of Maine (UMaine) project, described below, *may affect, but is not likely to adversely affect* species of ESA-listed fish, mammals, and turtles. These include three fish species: Atlantic salmon, Atlantic sturgeon, and shortnose sturgeon; five species of whales: North Atlantic right, fin, humpback, sei, and sperm whales; and three species of sea turtles: Atlantic Ridley, loggerhead, and leatherback.

Essential Fish Habitat (EFH) has been designated in the test site area for 16 federally-managed fish and their various life stages under the Magnuson-Stevens Fishery Conservation and Management Act (MSA). In addition, as noted by NMFS in a letter to DOE dated November 16, 2012, the waters in the vicinity of Castine support populations of diadromous species including blueback herring, alewife, rainbow smelt, striped bass, American eel, and American shad. Diadromous fish serve as prey for a number of federally-managed species and several species are considered a component of EFH pursuant to the MSA.

In addition to the five species of whales listed under the ESA, a number of other marine mammals could occur in the test site or surrounding region, including harbor seals, grey seals, minke whales, harbor porpoise, Atlantic white-sided dolphin, common dolphin, short- and long-finned pilot whales, and Kogia. Marine mammals are protected under the Marine Mammal Protection Act (MMPA) of 1972, which restricts the taking, possession, transportation, selling, offering for sale, and importing of marine mammals. We are requesting a concurrence with NMFS that incidental take of marine mammals is unlikely to occur.

### **Background and Project Summary**

DOE is proposing to authorize the expenditure of Congressionally Directed federal funding to UMaine to deploy, test, and retrieve one small-scale floating turbine offshore of Castine, in Hancock County, Maine (Project). DOE has previously authorized the expenditure of federal funding by UMaine to conduct similar deployment, testing, and retrieval activities at the UMaine Deepwater Offshore Wind Test Site at Monhegan Island, Maine (Monhegan test site).

UMaine originally planned to fabricate and temporarily deploy up to two, 1/3-scale turbines at the Monhegan test site. Per the National Environmental Policy Act (NEPA) and DOE's NEPA

implementing regulations, an Environmental Assessment (DOE/EA-1792, DOE 2011) was completed for the Monhegan site project. Upon completion of the EA, DOE issued a Finding of No Significant Impact (September 2011). Per requirements under Section 7 of the Endangered Species Act (ESA), DOE initiated informal consultation with NMFS for that project. In a letter dated August 2011, NMFS concurred that the temporary deployment of those turbines may affect, but is not likely to adversely affect listed species. Since completion of this EA and ESA consultation, UMaine has changed the scope of their project and has proposed to downscale the size of the tower and turbine from 1/3 scale to 1/8 scale. Because of the change, UMaine is now proposing to deploy their Project at a more sheltered nearshore location just west of Castine, Maine (Figure 1) (Castine site) for the initial testing.

Under the new scope, the University would deploy a 20 kilowatt Renewegy wind turbine onto a floating platform. The platform would be located in an existing cableway in water that is about 100 feet deep. The turbine would measure about 41 feet from waterline to the hub, the rotor diameter would measure about 32 feet, and the total turbine height would be about 57 feet. The platform would be moored with drag embedment anchors, which are similar to boat anchors, and catenary mooring lines. In the event that the drag embedment anchors prove infeasible, UMaine would use four gravity anchors. The turbine would be connected to the Central Maine Power grid via a cable that would be temporarily installed about 500 to 1,000 feet along the seabed and existing cableway to shore. From the high tide line, the cable would extend about 300 feet along the ground in a protective conduit to the point of interconnection near Dyce's Head Road. The conduit would be removed at the end of the project.

The Project would be deployed for up to four months in the spring and early summer of 2013. During testing, the performance would be monitored to study and validate the Project design, a necessary step prior to deployment into the open ocean Monhegan test site. During the Castine site testing, the University would use platform installed sensors and telemetry systems in order to evaluate how their design performs under varying wind and wave conditions. Environmental monitoring for birds (visual surveys and web camera observation), marine mammals (visual surveys), bats (echolocation detectors), and benthic invertebrates (remotely operated vehicle surveys and visual surveys) has been ongoing by UMaine since 2012. These studies would continue in the area surrounding the test site during the deployment. In addition, acoustic detection of tagged fish in the area surrounding the test site occurs with acoustic receivers located nearby, and this monitoring would continue during the deployment.

In a letter dated October 18, 2012, DOE requested from your agency a list of threatened, endangered, proposed species, and/or designated or proposed critical habitat under NMFS jurisdiction that "may be present" within the project area. In response to this inquiry, NMFS provided information on ESA-listed species, marine mammals and diadromous fish species that may occur in the project area, and EFH. DOE is also consulting with the U.S. Fish and Wildlife Service regarding species protected under the Endangered Species Act and other trust resources managed by that agency.

### **Threatened and Endangered Species**

**Fish** - Three fish species, all anadromous, listed under the ESA have the potential to occur in the project area. The Atlantic salmon, Gulf of Maine Distinct Population Segment, is federally endangered, shortnose sturgeon is federally endangered, and Atlantic sturgeon is listed as federally threatened for the Gulf of Maine Distinct Population Segment (DPS) and federally



endangered for the New York Bight DPS<sup>1</sup>. The proposed project is not located within any currently designated critical habitat for any ESA-listed fish species.

All three species were detected at the Dyce Head acoustic detection array during monitoring from 2009 to 2011. Movements through the array were seasonal with Atlantic salmon movements focused in May, Atlantic sturgeon movements throughout the year but focused in May and October, and shortnose sturgeon movements occurring from May to July (Zydlowski 2012). These three species use the project area as a migration corridor. This part of Penobscot Bay is very expansive and quite deep, and the project would not obstruct these species as they swim into and out of the Penobscot River and estuary. The small size of this research project relative to the surrounding marine habitat, the short nature of the deployment, the limited time these migratory fishes would be in the project site, and the overall lack of potential mechanism for effect to fish, all minimize the risk of effect to these three species.

**Marine Mammals** – Five ESA-listed whales that have the potential to occur in waters offshore of Maine are North Atlantic right, fin, humpback, sei, and sperm whales. None of these species were observed during the 17 boat-based visual surveys conducted in the project area by UMaine in 2012 (Kennedy 2012), nor are they expected to occur near shore in upper Penobscot Bay where the project is located. The likelihood of exposure of ESA-listed whales to the proposed project is extremely small, given that ESA-listed whales are uncommon in the project area, the small size of the project relative to the surrounding Penobscot Bay, and the fact that the platform would be temporarily deployed for up to four months. In addition, the mass/buoyancy of the platform and mass of the anchors is expected to create substantial tension in the mooring lines, which would prevent the formation of loops that could entangle a passing animal.

Underwater sound generated from the turbine and mooring system could potentially affect whales and other marine mammals. However, sound levels underwater resulting from turbine noise transferred through the sea surface are expected to be substantially lower than the sound source levels, due to the reflective nature of the sea surface (Jones et al. 2010). Acoustic emissions underwater, due to vibrations of the turbine and platform structure, are expected to be low frequency and low amplitude, and are strongly dependent on turbine and platform configuration and dynamic loads (Jones et al. 2010). Because of the low level of noise created by a Renewegy 20 kW turbine, the temporary nature of the deployment, and because only a small amount of sound can transfer through the sea surface from above, underwater noise levels resulting from turbine operation are expected to be very low. In addition, as discussed in the August 2011 letter from NMFS to DOE regarding the deployment of turbines offshore of Monhegan Island, measured and predicated levels of noise from operating wind turbines for offshore wind projects in Europe generally were below background sound levels.

**Turtles** - There are three ESA-listed sea turtles with the potential to occur in the Gulf of Maine: Atlantic Ridley, loggerhead, and leatherback sea turtles. Sea turtle sightings in the Gulf of Maine are rare, and these species are very unlikely to occur near shore in upper Penobscot Bay where the project is located. The likelihood of exposure of sea turtles to the proposed project is extremely small given that sea turtles are uncommon in the project area, the small size of the project relative to the surrounding Penobscot Bay, and the fact that the platform would be temporarily deployed for up to only four months. Also, the substantial tension in the mooring lines would prevent the formation of loops that could entangle a passing animal. No other

---

<sup>1</sup> NMFS (2012) estimated that 1% of Atlantic sturgeon in the Penobscot River are New York Bight origin, based on a mixed stock analysis conducted in the Bay of Fundy, Canada that concluded that 1% of Atlantic sturgeon in the Bay of Fundy were New York Bight origin.

potential effects on sea turtles are anticipated.

Based on this information, DOE concludes that the effects to threatened and endangered fish, marine mammals, and sea turtles would be insignificant and discountable, and that the project is not likely to adversely affect these species.

#### **Magnuson-Stevens Fisheries Conservation Act and Fish and Wildlife Coordination Act**

There are a number of federally managed fish species with EFH in waters off of Castine. Habitat types that represent EFH include all portions of the water column or substrate types, such as soft bottom, hard bottom, and various mixtures of hard and soft (NOAA 2012). The footprint of the anchors and cable might slightly decrease available bottom foraging habitat and areas considered to be EFH. However, the maximum area covered by the anchors (combined area of about 64 ft<sup>2</sup> for drag embedment anchors, 400 ft<sup>2</sup> if gravity anchors are used) and the 2½-inch subsea cable and associated strip weights (footprint of about 357 ft<sup>2</sup>) would be very small, and the type of habitat to be disturbed is very prevalent along the Maine coast. Placement of anchors and the subsea cable in areas of soft bottom substrate would likely result in a temporary and localized increase in turbidity during deployment and removal; with only four anchors to be deployed, this effect would be small scale and short term, and recovery from any disturbance to the bottom is expected to occur quickly. Mobile species such as fish, would likely avoid the immediate deployment area during project installation activities. Project deployment activities for the marine components of the project are expected to total five days (two days to deploy the four anchors, one day to deploy the floating turbine platform, and two days to deploy the subsea cable). Project removal activities would take a similar amount of time. Therefore, any shift in habitat use by marine or diadromous species during installation or removal activities would be small scale and temporary and impacts of the project on EFH will be minimal.

#### **Marine Mammal Protection Act**

During the 17 boat-based surveys UMaine conducted in the project vicinity, 66 harbor seals, one gray seal, and 34 harbor porpoise were observed. No large whales or other marine mammals were observed (Kennedy 2012). Harbor seals, gray seals, and harbor porpoise would likely avoid the immediate vicinity of the project during deployment and removal activities. While the potential for a vessel and marine mammal interaction is unlikely, NMFS marine mammal avoidance procedures, in compliance with the Marine Mammal Protection Act, would be implemented in the event that a marine mammal is encountered by a service vessel. The small scale of the project and the short duration of deployment and removal activities are expected to minimize any disturbance to marine mammals caused by deployment and removal of the project.

The presence of floating turbine platforms in the water column and floating above the water may result in temporary altered use by marine life. For example, seals are known to haul out on nearly any accessible floating platform. UMaine is implementing design measures to prevent seal haul out (the platform deck will be raised several feet above the water level). Because of the small size and temporary nature of the project, it is not expected that it would change the habitat or the marine community in the deployment area in other ways (e.g. artificial reef effect, fish aggregation [FAD] effect, avoidance of the project area by resident and migratory species).

Because of the acute sensory capabilities of toothed whales (echolocation) and the small size and maneuverability of seals, it is expected that the marine mammal species that occur in the project area would be able to detect and avoid underwater moorings. Collisions with mooring cables and the floating platform are extremely unlikely because of the low probability of a marine mammal encountering the project and because marine mammals expected to occur in

the area have well-developed sensory abilities (echolocation or vision) that allow them to avoid structures. Entanglement in mooring cables is unlikely because of the tension which would prevent looping.

Based on the minimal potential for interaction with marine mammals and any negative impact from these interactions, DOE finds that incidental take of marine mammals is unlikely to occur during the deployment, operation, and retrieval of the UMaine Project Castine test site.

DOE is in the process of developing a Supplemental EA to cover these new activities at the Castine test site. The Draft Supplemental EA was posted on DOE's website on January 10, 2013. A DOE EA Notification of Availability was sent to NMFS staff at that time. Additional background information and analysis can be found in this document and can be viewed at [www.eere.energy.gov/golden/Reading\\_Room.aspx](http://www.eere.energy.gov/golden/Reading_Room.aspx).

If you have any questions, please contact me at 720-356-1322 or via my email at [Laura.Margason@go.doe.gov](mailto:Laura.Margason@go.doe.gov).

Sincerely,



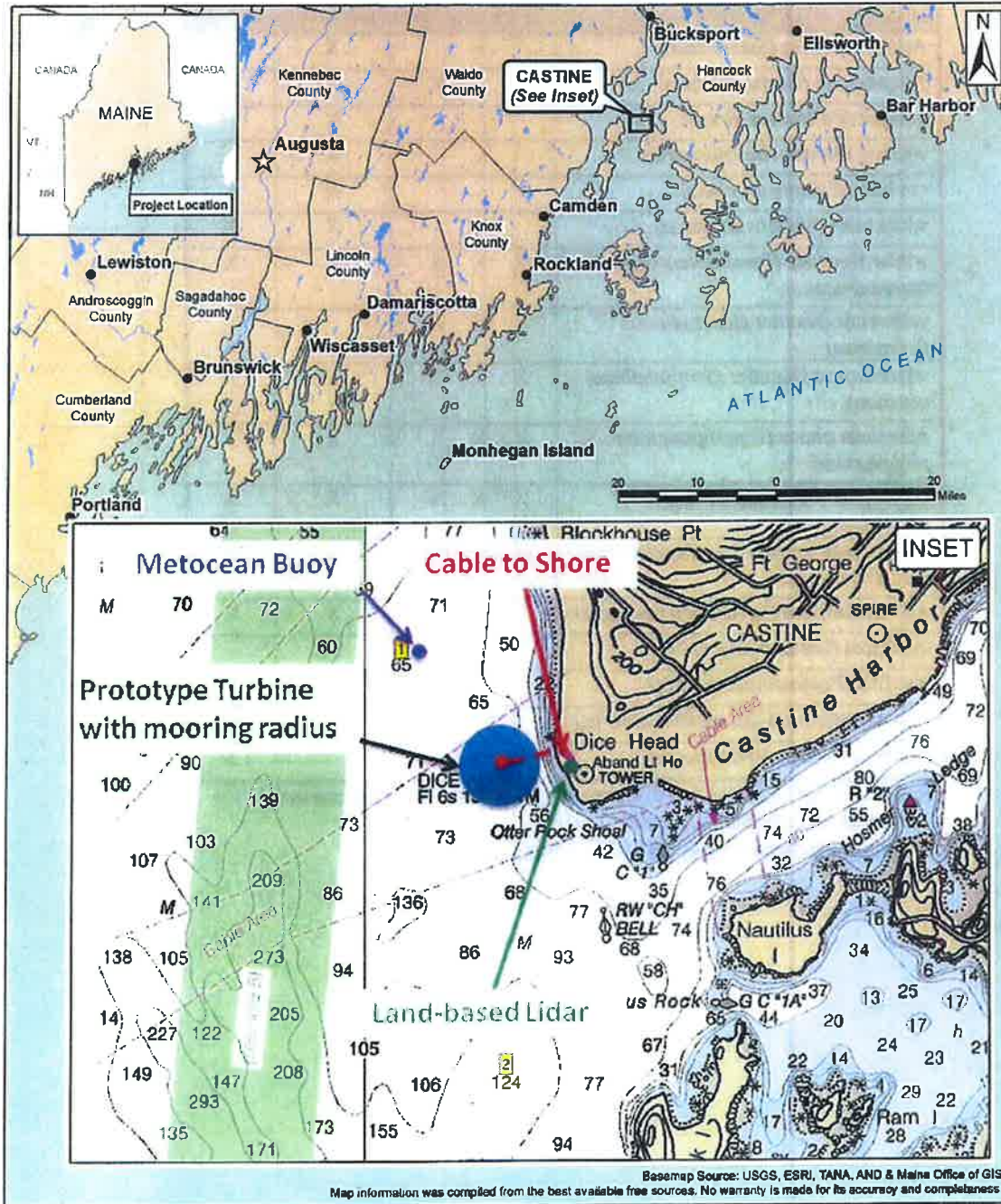
Laura Margason  
NEPA Document Manager

Cc: Michael Johnson, National Marine Fisheries Service  
David Bean, National Marine Fisheries Service  
Michelle Magliocca, National Marine Fisheries Service

## References

- Jones, M., P. Ramuhalli, and M. Watkins. 2010. *Characterization of acoustic noise propagation from offshore wind turbines – white paper*. Pacific Northwest National Laboratory, Richland, WA. Unpublished.
- Kennedy, L. 2012. Visual Observations for Birds, Turtles, and Marine Mammals at the University of Maine Test Site near Castine, Maine. Prepared by Lubird Kennedy Environmental Services for the University of Maine's Advanced Structures and Composites Center. September, 2012.
- National Oceanic and Atmospheric Administration (NOAA). 2012. Guide to Essential Fish Habitat Designations in the Northeastern United States. [Online] URL: <http://www.nero.noaa.gov/hcd/index2a.htm>. (Accessed October 2012).
- U.S. Department of Energy (DOE). 2011. Final Environmental Assessment for University of Maine's Deepwater offshore Floating Wind Turbine Testing and Demonstration Project, Gulf of Maine. DOE, Office of Energy Efficiency and Renewable Energy, Golden Field Office. September 2011. Available online at:
- [http://www.eere.energy.gov/golden/NEPA\\_FEA\\_FONSI.aspx](http://www.eere.energy.gov/golden/NEPA_FEA_FONSI.aspx).
- Zydlewski, G.B. 2012. Dice Head Acoustic Receiver Array Detections 2009-2011. Data collected by: University of Maine, School of Marine Sciences and School of Biology and Ecology; NOAA Fisheries Maine Field Station, NEFSC; and USGS Maine Cooperative Fish and Wildlife Research Unit.

**FIGURE 1**  
**PROPOSED LOCATION OF DEPLOYMENT OF**  
**FLOATING OFFSHORE WIND TURBINE PLATFORM.**



**TABLE 1****MARINE SPECIES AND LIFE STAGES FOR WHICH ESSENTIAL FISH HABITAT OCCURS IN WATERS OFF OF CASTINE.**

Species	Eggs	Larvae	Juveniles	Adults
Atlantic salmon ( <i>Salmo salar</i> )			X	X
Atlantic cod ( <i>Gadus morhua</i> )		X	X	X
pollock ( <i>Pollachius virens</i> )			X	
whiting ( <i>Merluccius bilinearis</i> )			X	X
red hake ( <i>Urophycis chuss</i> )			X	X
white hake ( <i>Urophycis tenuis</i> )			X	X
winter flounder ( <i>Pseudopleuronectes americanus</i> )	X	X	X	X
yellowtail flounder ( <i>Limanda ferruginea</i> )	X	X		
windowpane flounder ( <i>Scophthalmus aquosus</i> )	X	X	X	X
American plaice ( <i>Hippoglossoides platessoides</i> )	X	X	X	X
ocean pout ( <i>Macrozoarces americanus</i> )	X	X	X	X
Atlantic sea scallop ( <i>Placopecten magellanicus</i> )	X	X	X	X
Atlantic sea herring ( <i>Clupea harengus</i> )		X	X	X
monkfish ( <i>Lophius americanus</i> )				
bluefish ( <i>Pomatomus saltatrix</i> )			X	X
Atlantic mackerel ( <i>Scomber scombrus</i> )			X	X
bluefin tuna ( <i>Thunnus thynnus</i> )				X

Source: NOAA. 2012. Guide to Essential Fish Habitat Designations in the Northeastern United States. [Online] URL: <http://www.nero.noaa.gov/hcd/STATES4/nmaine.htm>.



**Department of Energy**  
Golden Field Office  
1617 Cole Boulevard  
Golden, Colorado 80401-3393

January 16, 2013

Mr. Mark McCollough  
Field Supervisor  
U.S. Fish & Wildlife Service  
17 Godfrey Drive, Suite 2  
Orono, ME 04473

**Subject: Section 7 Endangered Species Consultation for the University of Maine Testing of a Floating Offshore Wind Turbine Platform, Castine, Maine**

Dear Mr. McCollough:

The U.S. Department of Energy (DOE) is requesting concurrence from the U.S. Fish & Wildlife Service (USFWS) that the proposed University of Maine (UMaine) project, described below, *may affect, but is not likely to adversely affect* either the ESA-listed roseate tern (endangered) or piping plover (threatened).

### **Background**

In response to a 2010 Congressional Directive, the U.S. Department of Energy (DOE) has awarded federal funding to the University of Maine and is proposing to authorize expenditure of that funding to deploy, test, and retrieve one small-scale floating turbine offshore of Castine, in Hancock County, Maine (Project). DOE has previously authorized the expenditure of federal funding by UMaine to conduct a similar project at the UMaine Deepwater Offshore Wind Test Site adjacent to Monhegan Island, Maine (Monhegan test site).

UMaine originally planned to fabricate and temporarily deploy up to two, 1/3-scale turbines at the Monhegan test site. Per the National Environmental Policy Act (NEPA) and DOE's NEPA implementing regulations, an Environmental Assessment (DOE/EA-1792, DOE 2011) was completed for the Monhegan site project. Upon completion of the EA, DOE issued a Finding of No Significant Impact (September 2011). Per requirements under Section 7 of the Endangered Species Act (ESA), DOE initiated informal consultation with the USFWS for that project. In August 2011, the USFWS concurred that the temporary deployment of those turbines *may affect, but is not likely to adversely affect* roseate terns and piping plovers. Since completion of this EA and ESA consultation, UMaine has changed the scope of their project and has proposed to downscale the size of the tower and turbine from 1/3 scale to 1/8 scale. Because of the change, UMaine is now proposing to deploy their Project at a more sheltered nearshore location just west of Castine, Maine (Figure 1) (Castine site) for the initial testing.

## **Project Summary**

Under the new scope, the University would deploy a 20 kilowatt Renewegy wind turbine onto a floating platform. The platform would be located in an existing cableway in water about 100 feet deep and would be moored with catenary mooring lines and either a drag embedment or gravity anchors. The turbine would measure approximately 41 feet from waterline to the hub, the rotor diameter would measure about 32 feet, and the total turbine height would be about 57 feet. The turbine would be connected to the Central Maine Power grid via a cable that would be temporarily installed about 500 to 1,000 feet along the seabed and existing cableway to shore. From the high tide line, the cable would extend about 300 feet along the ground in a protective conduit to the point of interconnection near Dyce's Head Road. The conduit would be removed at the end of the project.

The Project would be deployed for up to four months in the spring and early summer of 2013. During testing, the performance would be monitored to study and validate the design, a necessary step prior to deployment into the open ocean Monhegan test site. During the Castine site testing, the University would use platform installed sensors and telemetry systems in order to evaluate how their design performs under varying wind and wave conditions. Environmental monitoring for birds (visual surveys and web camera observation), marine mammals (visual surveys), bats (echolocation detectors), and benthic invertebrates (remotely operated vehicle surveys and visual surveys) has been ongoing by UMaine since 2012. These studies would continue in the area surrounding the test site during the four month Project deployment.

## **Determination and Rationale**

In a letter dated October 18, 2012, DOE requested from your agency a list of threatened, endangered, proposed species, and/or designated or proposed critical habitat under your jurisdiction that "may be present" within the project area. It was determined that two species may be present: roseate tern and piping plover. The test site does not contain critical habitat for either species. DOE is also consulting with the National Marine Fisheries Service regarding marine species protected under the Endangered Species Act and other trust resources managed by that agency.

The operation of the proposed Project would introduce static and moving above-water components at the site, potentially within the flyway of birds. During Project operation, migrating and foraging birds could be at risk of colliding with the turbine. As described below, there is a very low probability of birds being killed or injured by the four month deployment of the 1/8-scale floating turbine design.

The proposed Renewegy turbine would have a rotor diameter of 31.5 feet and a rotor-sweep zone ranging from approximately 25 feet to 57 feet above the water surface. Of the 456 flying birds observed during the 17 surveys UMaine conducted from March through June, 2012, the majority flew at 16.4 feet (5 meters) above the water surface and 40% flew 3.2 feet (1 meter) or



less above the surface (Figure 2). Approximately 19% flew within the height of the rotor sweep zone (Kennedy 2012). One unidentified tern (*Sterna* sp.) and no piping plovers were observed during the surveys.

Although a low probability, there is a chance some birds might collide with the turbine during the four-month deployment. However, the rotor swept area would be 779 feet<sup>2</sup>, which is much smaller than the 1/3-scale turbines evaluated at the Monhegan site, which had a rotor swept area of 6,165 feet<sup>2</sup>, almost eight times larger. The relatively small rotor diameter of the 20 kilowatt turbine and the temporary nature of the Project would minimize any collision risk for birds. During the period of deployment, boat based visual surveys of birds would be performed on site weekly and a web camera would be installed on the turbine to monitor potential bird strikes. Visual observation methods would replicate the ongoing pre-deployment monitoring activities.

As the majority of avian species have been detected flying above or below the turbine-swept area, and the proposed Project would be of small scale and have a short operational duration, the likelihood of either two ESA-listed species interacting with the turbine rotors is minor and affects would be negligible. For these reasons, DOE concludes that the Project *may affect, but is not likely to adversely affect* the ESA-listed roseate tern or piping plover.

DOE is in the process of developing a Supplemental EA to cover these new activities at the Castine test site. The Draft Supplemental EA was posted on DOE's website on January 10, 2013. A DOE EA Notification of Availability was sent to USFWS staff at that time. Additional background information and analysis can be found in this document and can be viewed at [www.eere.energy.gov/golden/Reading\\_Room.aspx](http://www.eere.energy.gov/golden/Reading_Room.aspx).

If you have any questions, please contact me at 720-356-1322 or via my email at [Laura.Margason@go.doe.gov](mailto:Laura.Margason@go.doe.gov).

Sincerely,



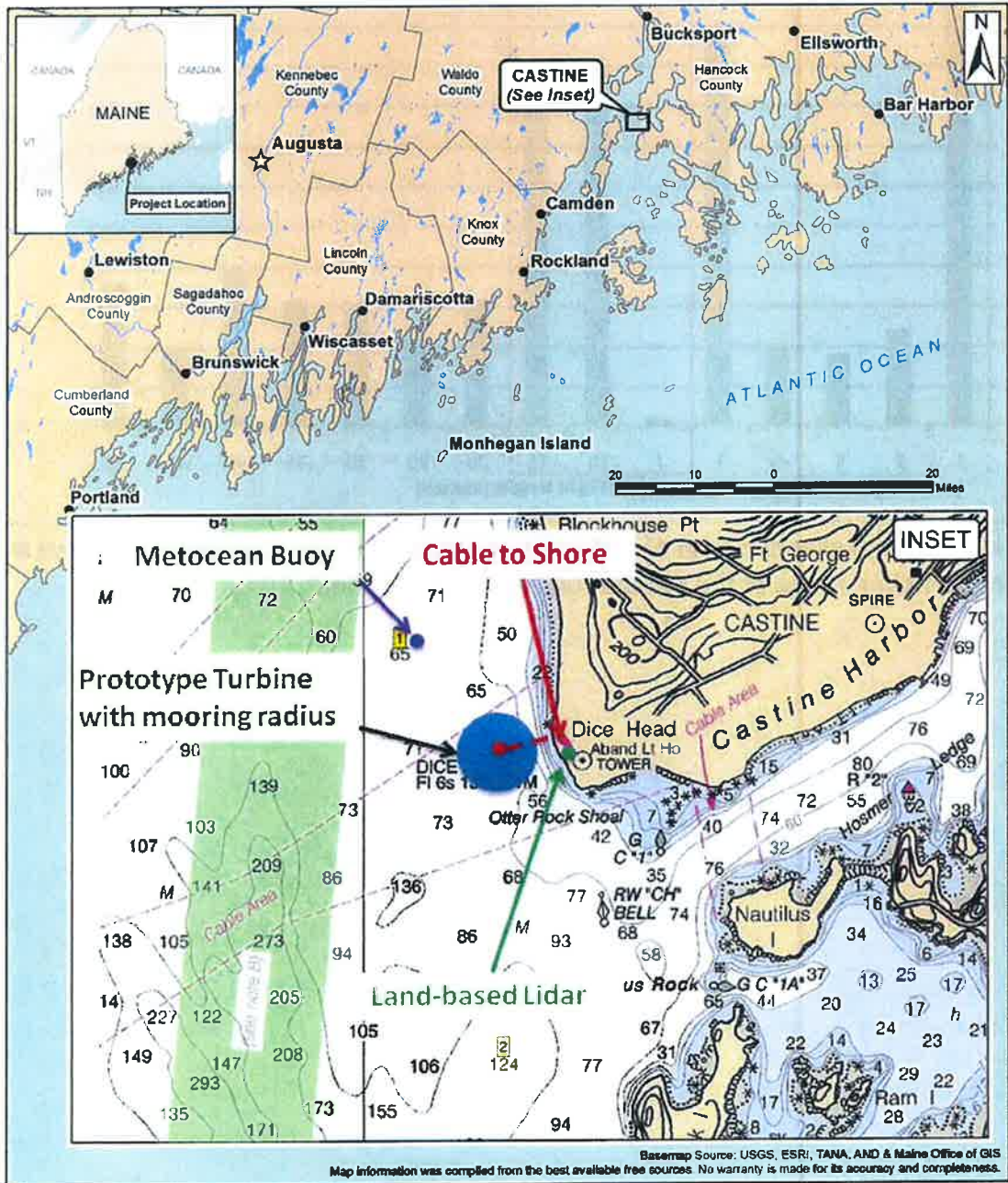
Laura Margason  
NEPA Document Manager

### References

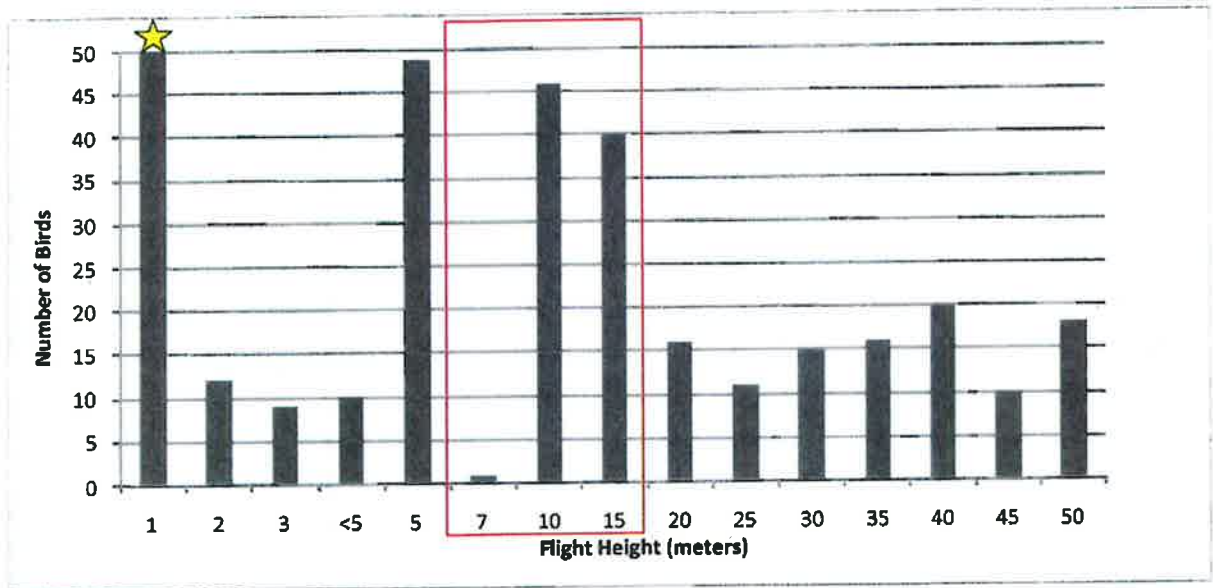
Kennedy, L. 2012. Visual Observations for Birds, Turtles, and Marine Mammals at the University of Maine Test Site near Castine, Maine. Prepared by Lubird Kennedy Environmental Services for the University of Maine's Advanced Structures and Composites Center. September, 2012.

U.S. Department of Energy (DOE). 2011. Final Environmental Assessment for University of Maine's Deepwater offshore Floating Wind Turbine Testing and Demonstration Project, Gulf of Maine. DOE, Office of Energy Efficiency and Renewable Energy, Golden Field Office. September 2011. Available online at: [http://www.eere.energy.gov/golden/NEPA\\_FEA\\_FONSI.aspx](http://www.eere.energy.gov/golden/NEPA_FEA_FONSI.aspx).

**FIGURE 1**  
**PROPOSED LOCATION OF DEPLOYMENT OF the UMAINE FLOATING OFFSHORE WIND TURBINE PLATFORM PROJECT.**



**FIGURE 2**  
**FLIGHT HEIGHTS FOR BIRD SPECIES OBSERVED**  
**DURING UMAINE 2012 VISUAL SURVEYS.**



The yellow star represents a total of 183 birds at one meter high. The red box shows the approximate height range of the turbine rotor. Source: Kennedy 2012.



UNITED STATES DEPARTMENT OF COMMERCE  
National Oceanic and Atmospheric Administration  
NATIONAL MARINE FISHERIES SERVICE  
NORTHEAST REGION  
55 Great Republic Drive  
Gloucester, MA 01930-2276

FEB 20 2013

Laura Margason  
Department of Energy  
NEPA Document Manager  
Golden Field Office  
1617 Cole Boulevard  
Golden, Colorado 80401 -3393

Re: UMaine offshore wind turbine interim demonstration project, Castine, Maine

Dear Ms. Margason,

We have reviewed your January 16, 2013, letter requesting consultation under section 7 of the Endangered Species Act (ESA) of 1973 as amended and the Essential Fish Habitat (EFH) provisions of the Magnuson-Stevens Fishery Conservation and Management Act (MSA) for the University of Maine's (UMaine) proposed interim offshore wind project near Castine, Maine. You have made the determination that the proposed project may affect, but is not likely to adversely affect any species listed as threatened or endangered by NMFS, and that the proposed project would have minimal adverse effects on EFH that has been designated within the project area. Since all effects of the proposed action will be insignificant and discountable, we concur with your determination that the proposed project may affect, but is not likely to adversely affect any ESA listed species under our jurisdiction. In addition, we concur with your determination that the proposed project would have minimal adverse effects on EFH. Our conclusions are based on information provided in a Draft Supplemental Environmental Assessment (DSEA) (DOE/EA-1792S Jan. 2013). The justifications for our determinations are outlined below.

Funding for the demonstration project comes largely from the Department of Energy (DOE), so the federal actions associated with the deployment of the test unit are the delegation of funds by the DOE and the issuance of a permit under Section 10 of the Rivers and Harbors Act by the US Army Corps of Engineers (ACOE). The DOE is the lead Federal agency for the project for purposes of this consultation and coordination under the National Environmental Policy Act.

### **Proposed Project**

The project involves the temporary deployment and testing of a 1/8 scale wind turbine within state waters offshore of Castine, Maine, by the University of Maine (Figure 1). UMaine proposes to use DOE funding to deploy and retrieve one 20-kW wind turbine on a floating platform located offshore of Castine, Maine. In addition, UMaine proposes to conduct initial



testing of the floating platform and wind turbine system. The turbine would be connected to the Central Maine Power (CMP) grid via an electrical cable to be installed along the seabed surface in an existing cable right-of-way (ROW) from below the turbine to shore, and above ground to an existing CMP power pole. The turbine platform would carry sensor and telemetry systems that would provide data to evaluate the engineering, structural, and motion performance of the turbine platform under combined wind, wave, and environmental conditions. Additionally, environmental monitoring for birds (visual surveys and web camera observation), marine mammals (visual surveys), bats (echolocation detectors), and benthic invertebrates (remotely operated vehicle surveys and visual surveys), which was initiated by UMaine in 2012 to support development of the DSEA, would continue in the area surrounding the test site during the deployment. Further, ongoing acoustic monitoring of tagged fish in the project area will also continue.

The floating platform consists of a pre-formed concrete structure which is held in place by multiple anchor points on the sea floor in approximately 100 feet of water. A wind turbine and monitoring equipment will be mounted on the platform and will stand approximately 57 feet above mean sea level (MSL). The floating platform on which the wind turbine is mounted will be constructed onshore and will be towed to the proposed deployment site via a tug boat. We anticipate it will take approximately two hours to tow the floating turbine from the launch site to the final destination at Dyce Head, Castine. Notice would be given to the Maine Marine Patrol and United States Coast Guard (USCG) to alert fishermen about towing operations and to advise for the removal of gear from the planned tow route. Upon arrival at the site, the structure will be connected to the mooring structure in place and secured to the ocean floor via catenary mooring lines and four embedded anchors. Deployment operations are expected to occur in several stages starting in early spring of 2013 to place anchors, followed by towing the fully assembled structure from a shore based facility to the deployment site, and setting the platform and wind turbine unit in place. The anticipated time required for project installation would be two days to deploy the four anchors, one day to install the turbine platform, two days to install the subsea cable, and two weeks for the land-based work.

The demonstration unit will remain in place during the spring of 2013 for a period of four months (i.e., April through July) to collect engineering and environmental data on site. The floating offshore wind turbine system would be retrieved from Castine at the end of the deployment period in late July or early August. At the end of the scheduled deployment, the structure will be removed by disconnecting the deepwater platform from the anchors and towing it back to the shore for disassembly. It is possible that unanticipated removal of the turbine would be necessary in the case of an extreme weather event. Therefore, the design incorporates the capability to disconnect the floating turbine system from its moorings and tow it safely to port. The removal of the floating turbine system and its associated moorings would be completed in two stages: 1) removal of the floating turbine system and; 2) removal of the catenary moorings lines and anchors. All electrical interconnection equipment also would be removed at the conclusion of the test.

Additional periodic visits to the floating platform and wind turbine will be required to visually inspect the structure, perform general maintenance of instruments, and address other issues as

they arise. The frequency of visits will vary depending on purpose and weather conditions. Towing of the structures from shore out to the site and back will be performed via tug boats, other smaller vessels will be used for routine maintenance, operations and monitoring activities associated with the project. The onboard management of fuels and lubricating fluids aboard all vessels would be managed in accordance with USCG regulations applicable to each vessel. The requirements are dictated by vessel size and intended operations, but in each case do not permit the discharge of petroleum or hazardous substances into the environment and require a spill prevention plan and certificate of financial responsibility.

Power would be generated at the turbine at 480-V, 3-phase, and would be delivered to the CMP grid through a combination of submarine and land based cables. Beginning at the offshore turbine mooring anchor, the electrical cable would run along the seabed approximately 500 to 1,000 feet to the shore, just below the low tide line. The cable would be anchored to the seafloor using simple weight strands every five feet, and these would be removed with the cable at the project's conclusion. At the point the cable is exposed above ground, the cable would be contained in a Schedule 40 rigid metal conduit within the tidal zone and Schedule 80 polyvinyl chloride (PVC) from the high tide location to the CMP point of interconnection in order to meet electrical code requirements. The 2.5-inch PVC conduit would extend approximately 300 feet from the high tide line to the point of interconnection near Dyce's Head Road.

If you fund the proposed project, the following measures will be implemented by UMaine to minimize or avoid potential biological and environmental effects:

- To prevent seals from using the turbine platform for resting (seal haul out), the platform has been designed to limit the horizontal surfaces, and the platform deck height will preclude haul out of seals.
- The turbine tower will not have external ladders or other structures that will allow birds to perch near the turbine blades.
- The specifications for lighting of the floating platform and turbine will be developed in compliance with USFWS lighting requirements.
- UMaine will conduct monitoring for birds, bats, marine mammals, benthic invertebrates, and fish. The continued monitoring effort will complement the pre-deployment monitoring that has already been performed. Results of the monitoring will be provided to DOE and applicable resources agencies.
- NMFS marine mammal avoidance and best management procedures will be implemented in the event that a marine mammal is encountered by a construction or maintenance vessel [http://www.nero.noaa.gov/prot\\_res/mmv/approach.html](http://www.nero.noaa.gov/prot_res/mmv/approach.html).
- Fuels and lubricating fluids aboard all vessels will be managed in accordance with U.S. Coast Guard regulations applicable to each vessel.
- Following completion of the project, the floating turbine platform, anchors, and the electrical cable will be retrieved. The electrical cable anchors on shore will be removed, any bolts will be cut to flush with existing grade, and support blocks and the conduit will be removed. Disturbed areas will be stabilized with straw mulch.

### **NMFS Trust Resources in the Project Area**

The proposed project is located offshore of Castine, Maine at approximately N 44° 23' 07", W 68° 49' 25" (Figure 1). For purposes of the section 7 consultation, the action area is defined as "all areas to be affected directly or indirectly by the Federal action and not merely the immediate area involved in the action" (50CFR§402.02). For this project, the action area is limited to the project footprint and the transit route used by vessels delivering and servicing the platform. There is no critical habitat designated for any species under our jurisdiction in the action area. This area is expected to encompass all of the effects of the proposed project.

Several species of fish under our jurisdiction are likely to occur in the action area; these include, Atlantic sturgeon (*Acipenser oxyrinchus oxyrinchus*), shortnose sturgeon (*Acipenser brevirostrum*) and Atlantic salmon (*Salmo salar*).

The Gulf of Maine Distinct Population Segment (GOM DPS) of Atlantic salmon (*Salmo salar*) includes all anadromous Atlantic salmon whose freshwater range occurs in the watersheds from the Androscoggin River northward along the Maine coast to the Dennys River. Included are all associated conservation hatchery populations used to supplement these natural populations; currently, such conservation hatchery populations are maintained at Green Lake National Fish Hatchery (GLNFH) and Craig Brook National Fish Hatchery (CBNFH). This project is located within the range of the GOM DPS of Atlantic salmon.

The distribution of federally endangered shortnose sturgeon (*Acipenser brevirostrum*) in waters off the coast of Maine is not well understood or documented. In Maine, shortnose sturgeon are known to occur in the Penobscot River, the Kennebec/Sheepscot/Androscoggin River complex, the Saco River, and occasionally in several smaller coastal rivers. Limited information on coastal migrations is available; however, the best available information suggests that when in coastal waters, shortnose sturgeon are likely to occur closer to the coast.

New York Bight (NYB) and Gulf of Maine (GOM) Distinct Population Segments (DPSs) of Atlantic sturgeon occur in the action area. In 2012, four DPSs of Atlantic sturgeon were listed as endangered (NYB, Chesapeake Bay, Carolina, and South Atlantic) and one as threatened (GOM). We have considered the best available information on the distribution of Atlantic sturgeon and have determined that most Atlantic sturgeon in the action area are likely to be of GOM DPS origin. However, it is likely that some Atlantic sturgeon occurring in the action area are of Canadian origin (and therefore, not listed under the ESA) and a small portion of Atlantic sturgeon occurring in the action area are likely to be NYB origin. Further, recent information from telemetry studies conducted on sturgeon in the Gulf of Maine indicates many individuals are utilizing coastal bays and estuaries while migrating along the coast. Therefore, based on this information, we anticipate sub-adult and adult Atlantic and shortnose sturgeon to be present in the action area while participating in coastal migrations and for foraging.

Information on the distribution and movements from a variety of acoustically tagged listed fish (e.g., shortnose sturgeon, Atlantic salmon and Atlantic sturgeon), are available since 2005 from



acoustic receivers which have been deployed throughout the GOM. UMaine in collaboration with NMFS and United States Geological Survey (USGS), have been conducting telemetry studies to track the movements of listed Atlantic salmon, Atlantic sturgeon and shortnose sturgeon within the Penobscot River and through Penobscot Bay. This is a significant part of a larger effort across the GOM which includes other telemetry receivers and arrays deployed by Ocean Observing System/NERACOOS system (GOMOOS), Maine Department of Marine Resources and University of New England (Figure 2). Together, these receivers can provide detailed information on the location and movement of tagged individuals which pass the stationary acoustic tag detection units. For example, hundreds of juvenile Atlantic salmon smolts are tagged annually from the Penobscot River. Since 2006, approximately 20-30 adult shortnose sturgeon captured annually in the Penobscot River have been fitted with acoustic tags. Since 2005, the acoustic receivers, with a detection range of approximately 0.6 miles, have made over 9,000 detections of acoustic tags. These 9,000 detections were from 37 different individual acoustic tags.

More recently, data have been compiled for 2009, 2010 and 2011 from the acoustic array found adjacent to the project area off Dice Head, Castine, Maine (Figure 2). These data show all three species to be found in the vicinity of the project area, with some differences in detection times mostly dependant on seasonality (Zydlewski 2012). According to the acoustic tag report, movements of Atlantic salmon smolts through the Dice Head array started in late April and peaked in May, followed by Atlantic sturgeon movements throughout the year, increasing in frequency during May and October, in addition to, low numbers of shortnose sturgeon movements occurring from May through July. Some of the shortnose sturgeon had transmitters that also provided information on depth of movement. For the five individuals detected in 2009, their average depth of movement was  $34.6 \pm 4.4$  (mean  $\pm$  SD) feet. The channel in this reach of the bay can be up to 120 feet deep.

Three species of listed sea turtle species occur in New England waters during the warmer months, generally when water temperatures are greater than 15°C. The sea turtles in these waters are typically small juveniles with the most abundant being the federally endangered leatherback (*Dermochelys coriacea*), federally threatened loggerhead (*Caretta caretta*) and federally endangered Kemp's ridley (*Lepidochelys kempi*) sea turtles; however, Kemp's ridleys are rare in waters north of Massachusetts and only leatherback or loggerhead sea turtles are likely to occur in coastal Maine waters. Sea turtles move into waters off the coast of Maine from their southern wintering grounds in late June/July and most sea turtles move south from these waters by the first week in November. The highest numbers of sea turtles are present in these waters between July and October each year. Depths at the deployment site are approximately 100 feet, with an adjacent deep channel that reaches depths of 120 feet. Since the location of this site within Penobscot Bay is near shore in a coastal environment, it is anticipated sea turtles may pass through the project area during periods of migration and any use of the deployment area by sea turtles is likely to be transient. In addition, sea turtles may also occur seasonally along the vessel transit route while migrating or resting.

Listed whales also occur in the waters off the coast of Maine. In the action area, North Atlantic right whales (*Eubalaena glacialis*) as well as occasional humpback whales (*Megaptera*

*novaeangliae*) and fin whales (*Balaenoptera physalus*) could be present. These large whales are listed as endangered under the ESA and are also protected under the MMPA. Seals and porpoises are protected under the MMPA but are not listed under the ESA. During 2012, UMaine researchers conducted 17 marine mammal surveys while boating along dedicated transects that traversed the proposed test site. Visual observations included 66 harbor seals (*Phoca vitulina*), one grey seal (*Halichoerus grypus*), and 34 harbor porpoise (*Phocoena phocoena*), no large whales were encountered during the marine mammal surveys (Kennedy 2012). These data are consistent with strandings and observer data from the nearshore areas of the GOM. The action area is not a known concentration area for right whales; however, individual transient right whales could be present in the action area as individuals move between migration corridors and foraging areas. Similarly, while humpback and fin whales are not known to concentrate in the action area, occasional transient individuals could be present in the area year-round while migrating along the Atlantic coast or moving between foraging areas located in the GOM.

#### **Essential Fish Habitat and Fish and Wildlife Coordination Act**

As noted within the DSEA, the proposed project area has been designated as EFH for a range of federally managed species including, but not limited to Atlantic cod, haddock, and American plaice. Complex substrates consisting of rock, sand/gravel and mud are present within the proposed project area and serve as important habitats for benthic fish and shellfish resources. In addition, as you have noted, a number of NOAA-trust resources covered under the Fish and Wildlife Coordination Act (FWCA) consultation requirements occur in the project area. The FWCA requires that Federal agencies should consult with wildlife agencies, including NOAA, for projects that may modify a water body. Some of the species potentially affected include diadromous species such as blueback herring, alewife, rainbow smelt, striped bass, American eel, American shad and American lobster. Diadromous fishery resources also serve as prey for a number of federally-managed species and several species are considered a component of EFH pursuant to the MSA.

#### **Effects of the Action**

Potential effects to listed species from the deployment of the test platform mooring gear could result from extraneous noise, entanglement, entrapment, effects on benthic habitat or changes to the marine community composition in the area where the platform is moored, or interaction of marine mammals with the platform or its anchoring system and from interactions with project vessels as described below.

#### *Interactions or Entanglement with the Platform and its Anchoring System*

As explained above, the test unit will consist of a floating platform with four embedded anchors attached by cable, chain and/or synthetic material. As noted above, based on information from acoustic receivers, the location of the proposed project area overlaps with a migratory corridor used by juvenile and adult Atlantic salmon, Atlantic and shortnose sturgeon. Also, since we did not identify specific Primary Constituent Elements (PCEs) for an oceanic migratory corridor at the time of designating critical habitat, the action area does not occur within designated critical habitat for Atlantic salmon. Therefore, since it is unlikely that the placement

of the associated mooring structure will reduce the amount of forage available to migrating Atlantic salmon or otherwise affect migrating Atlantic salmon, we have determined any effects to listed Atlantic salmon will be insignificant. While Atlantic and shortnose sturgeon are susceptible to the effects to benthic resources identified herein, any effects to the benthic environment will be minor and temporary, and there is not likely to be any change in species composition or substrate type in the action area (see effects to marine and benthic resources below). Thus, we have determined that any effects to Atlantic and shortnose sturgeon resulting from the temporary deployment of mooring gear and electrical cable are insignificant and discountable.

We have considered the potential for whales and/or sea turtles to interact with the test unit and become entangled in its anchoring system. In order for an entanglement to occur, an animal must first encounter the gear. Since there will only be one test unit deployed in an open ocean environment in an area where listed species are not known to concentrate, the likelihood of a whale or sea turtle encountering the gear is extremely low. The catenary mooring system proposed to be used to anchor could potentially pose a risk of entanglement because the anchor lines would have a slightly horizontal orientation in the water column due to a 3:1 scope and depth of water. However, these anchor lines would be under high tensile loads and will be composed of synthetic material or steel cables and chains at least 2-3 inches in diameter, which should greatly reduce the risk of any entanglement of marine mammals. The proposed deployment of the floating platform and accompanying mooring system should reduce the risk of entanglement because of the: 1) tensile loads maintained in the catenary mooring design; 2) the diameter and composition of the anchor lines, and; 3) the mooring array is comprised of a limited number of vertical lines. Furthermore, humpback, right and fin whales can occur in the action area; however, occurrence in the action area is relatively rare and is likely to be limited to transient individuals. Similarly, while listed sea turtles also occur seasonally in the action area, the waters off of Maine are not high use areas for these species, occurrence in the action area is relatively rare, and is likely to be limited to transient individuals completing coastal migrations or moving between coastal foraging areas. Therefore, based on the analysis herein, it is extremely unlikely that a whale or sea turtle will interact with the test unit and become entangled. As such, we have determined that any effects to listed marine mammals and sea turtles from the deployment of the test unit on these species are insignificant and discountable.

#### *Underwater Sound Generated from Unit or Support Structure*

Underwater sound generated from the deployment of the floating platform and operation of the wind turbine along with the supporting mooring system gear could potentially affect marine mammals in the area. According to information provided in the DSEA, the Renewegy 20-kW turbine creates noise levels of about 50 dB at 120 feet (Renewegy 2012) and only a small amount of sound is expected to result from transfer of above-water sound through the sea surface. Underwater sound levels resulting from extraneous turbine noise transferred through the sea surface are expected to be substantially lower than the sound source levels, due to the reflective nature of the sea surface (Jones *et al.* 2010). Acoustic emissions underwater, due to vibrations of the turbine and platform structure are expected to be low frequency and low amplitude, and are strongly dependent on turbine and platform configuration and dynamic

loads (Jones *et al.* 2010). Due to the small scale of the project and composition of the floating platform, we do not anticipate underwater noise levels greater than 120 dB (the MMPA defines the threshold for Level B behavioral harassment for marine mammals as 120 dB for continuous noise and 160 dB for impulse sound). However, if the data collected during operation shows noise levels exceed this threshold, an Incidental Take Authorization for marine mammals would be necessary.

#### *Effects to Marine and Benthic Resources*

The mooring system is configured with embedded anchors which will be in contact with the seafloor for up to four months (Figure 3). An electrical cable will be temporarily installed on the ocean floor in a specified Right of Way (ROW). According to the DSEA, the actual footprint of project components resting on the seabed would be approximately 421 ft<sup>2</sup>, this would consist of the four anchors (combined footprint of 64 ft<sup>2</sup> at most) and the subsea cable and strip weights (combined footprint of about 357 ft<sup>2</sup>). In the event that gravity anchors are used instead of drag embedment anchors, each of the four anchors would have a footprint of 100 ft<sup>2</sup> (combined footprint of 400 ft<sup>2</sup>) for a total of approximately 757 ft<sup>2</sup>. This will result in the loss of an extremely small area of substrate available as potential foraging area (421 ft<sup>2</sup> or worst case scenario 757 ft<sup>2</sup>). Further, as deployment of the test unit will be temporary, and the placement of the electrical cables and mooring system will be temporary, any effects to the sea bottom and benthic resources will be temporary. The area where this gear is in contact with the bottom will not be available for foraging Atlantic and shortnose sturgeon and sea turtles that feed on benthic organisms. Therefore, considering the temporary limited benthic footprint of the proposed project from the placement of the mooring system and electrical cable (421 ft<sup>2</sup> or 757 ft<sup>2</sup>) will result in minimal impacts to EFH. However, there is also the potential for impacts resulting from anchorline scour during initial placement and operation of the test facility. We recommend the proposed monitoring plan include an assessment of benthic impacts resulting from the placement and configuration of electrical cables and anchors, as well as assess recovery of EFH once the mooring system is removed.

Leatherback sea turtles forage on jellyfish, while loggerheads feed on crustaceans and mollusks. Right whales feed on copepods, humpback whales feed on fish such as sand lance and herring, and fin whales feed on krill and other small schooling fish. The fish community structure in the immediate project vicinity could potentially be impacted from the placement of a floating platform and wind turbine. However, the distribution of fish is not likely to be affected by the placement of the test unit or the mooring system and other mobile benthic prey species such as crustaceans, crabs and shrimp are likely to move away from the immediate area where the test unit will be placed. Furthermore, the applicant has developed a monitoring plan to provide annual data for analysis to validate these assumptions. As such, annual reporting requirements will include both environmental and biological information to evaluate the changes to benthic and marine resources from the placement of the test platform and wind turbine unit. Therefore, we have determined there is not likely to be a significant reduction in the amount of forage available to sea turtles or whales in the action area. As there will be no anticipated reduction in sea turtle forage items and an extremely small reduction in the amount

of available benthic habitat, any effects to foraging sea turtles or whales will be insignificant and discountable.

### *Risk of Vessel Strike*

Collision with vessels remains a source of anthropogenic mortality for sea turtles, whales, and sturgeon. However, sturgeon vessel strikes typically occur in more confined regions such as rivers and given the location of the action area, it is unlikely that vessel strikes on sturgeon will occur. The deployment of the test unit as well as periodic maintenance and inspection will require the use of vessels; these vessels will represent an increase in vessel traffic in the action area. This increase in vessel traffic will result in some increased risk of vessel strike of listed marine mammals and sea turtles. However, due to the limited information available regarding the incidence of ship strike and the factors contributing to ship strike events, it is difficult to determine how a particular number of vessel transits or a percentage increase in vessel traffic will translate into a number of likely ship strike events or percentage increase in collision risk. In spite of being one of the primary known sources of direct anthropogenic mortality to whales, and to a lesser degree, sea turtles, ship strikes remain relatively rare, stochastic events, and an increase in vessel traffic in the action area would not necessarily translate into an increase in ship strike events. To compensate for the lack of site specific data, an ESA listed marine mammal monitoring plan will be in place for the term of the project to observe ESA listed marine mammal activity in the project area. The risk of collision is greatest when vessels are moving at high speeds. As identified in the DSEA, it is anticipated that towing the unit to and from the site will take approximately 2 hours and requires one tugboat. Average speed for platform towing operations is anticipated to be between approximately 2 and 4 knots. Once installation is completed, vessel speed returning to the mainland (and to the project for removal) will likely be typical commercial boat speed of approximately 12 knots. Other visits to the test unit are likely to be with a single vessel. Normal vessel speed traveling to and from the site for monitoring is anticipated to be approximately 20 knots. Lower speeds, ranging from 0 to 5 knots, will be necessary within the deployment site in order to observe the equipment and accurate collection fish and wildlife observation data. UMaine will implement NMFS marine mammal avoidance procedures in the event that a marine mammal is encountered by a construction or maintenance vessel. Additionally, project vessels will abide by the NMFS Northeast Regional Viewing Guidelines, as updated through the life of the project. The presence of a lookout on the vessel who can advise the vessel operator to slow the vessel or maneuver safely when listed species or marine mammals are spotted will further reduce the potential for interaction with vessels.

Large whales, particularly right whales, are vulnerable to injury and mortality from ship strikes. Although the threat of vessel collision exists anywhere listed species and vessel activity overlap, ship strike is more likely to occur in areas where high vessel traffic coincides with high species density. In addition, ship strikes are more likely to occur and more likely to result in serious injury or mortality when vessels are traveling at speeds greater than ten knots. Therefore, with a likelihood of encountering a whale low and the chance of vessel strike extremely low, we have determined that the increased risk of vessel collision posed by project vessel operation in the action area is insignificant.

**ESA Conclusions**

Based on the analysis concluding that all effects of the proposed project on listed species will be insignificant and discountable, we concur with the determination that the pilot deployment of one test unit in 2013 for a four month period (April through July) is not likely to adversely affect any listed species under our jurisdiction. Therefore, no further consultation pursuant to section 7 of the ESA is required. Reinitiation of consultation is required and shall be requested by the Federal agency or by us, where discretionary Federal involvement or control over the action has been retained or is authorized by law and: (a) If new information reveals effects of the action that may affect listed species or critical habitat in a manner or to an extent not previously considered in the consultation; (b) If the identified action is subsequently modified in a manner that causes an effect to the listed species or critical habitat that was not considered in the consultation; or (c) If a new species is listed or critical habitat designated that may be affected by the identified action.

**EFH and FWCA Conclusions**

We concur with your determination that adverse impacts to EFH and FWCA species and habitats will be minimal. According to your letter, a monitoring program has been in place since 2012 to evaluate the effects of the project on benthic resources and fish, and that this program will continue during the project deployment. We support this continued monitoring program, and request a copy of monitoring reports be sent to us for review upon completion of the project. Please also note that a distinct and further EFH consultation must be reinitiated pursuant to 50 CFR 600.920(1) if new information becomes available or the project is revised in such a manner that affects the basis for the above determination.

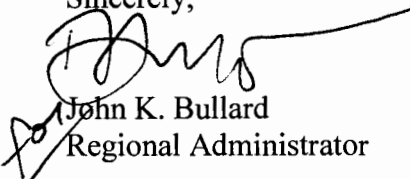
**Marine Mammal Conclusions**

Based on the information provided, we do not anticipate any impacts to marine mammals caused from extraneous noise, entanglement or vessel strike. If it is determined during the project deployment or due to alterations to the project technology, that activities could impact marine mammals, then we recommend that operations be suspended and UMaine either; 1) consult with us to implement further mitigation to avoid take or; 2) apply for an incidental take authorization pursuant to section 101 (a)(5)(A) and (D) of the MMPA.

Should you have any ESA related questions about this correspondence please contact David Bean at (207) 866-4172 or by e-mail (David.Bean@Noaa.gov). For questions in regards to effects to EFH and FWCA resources, please contact Michael Johnson at (978) 281-9130 or by

email (mike.r.johnson@Noaa.gov). For questions regarding the MMPA, please contact Michelle Magliocca in NMFS' Office of Protected Resources in Silver Spring, Maryland at (301) 427-8426 or by email (Michelle.Magliocca@Noaa.gov).

Sincerely,



John K. Bullard  
Regional Administrator

EC: Bean, F/NER3  
Magliocca, F/PR1  
Johnson, FNER4  
Boelke, F/NER4  
Jay Clement, ACOE

File Code: Sec 7 UMaine Offshore Wind Turbine Interim Castine, Maine  
PCTS: I/NER/2013/9477

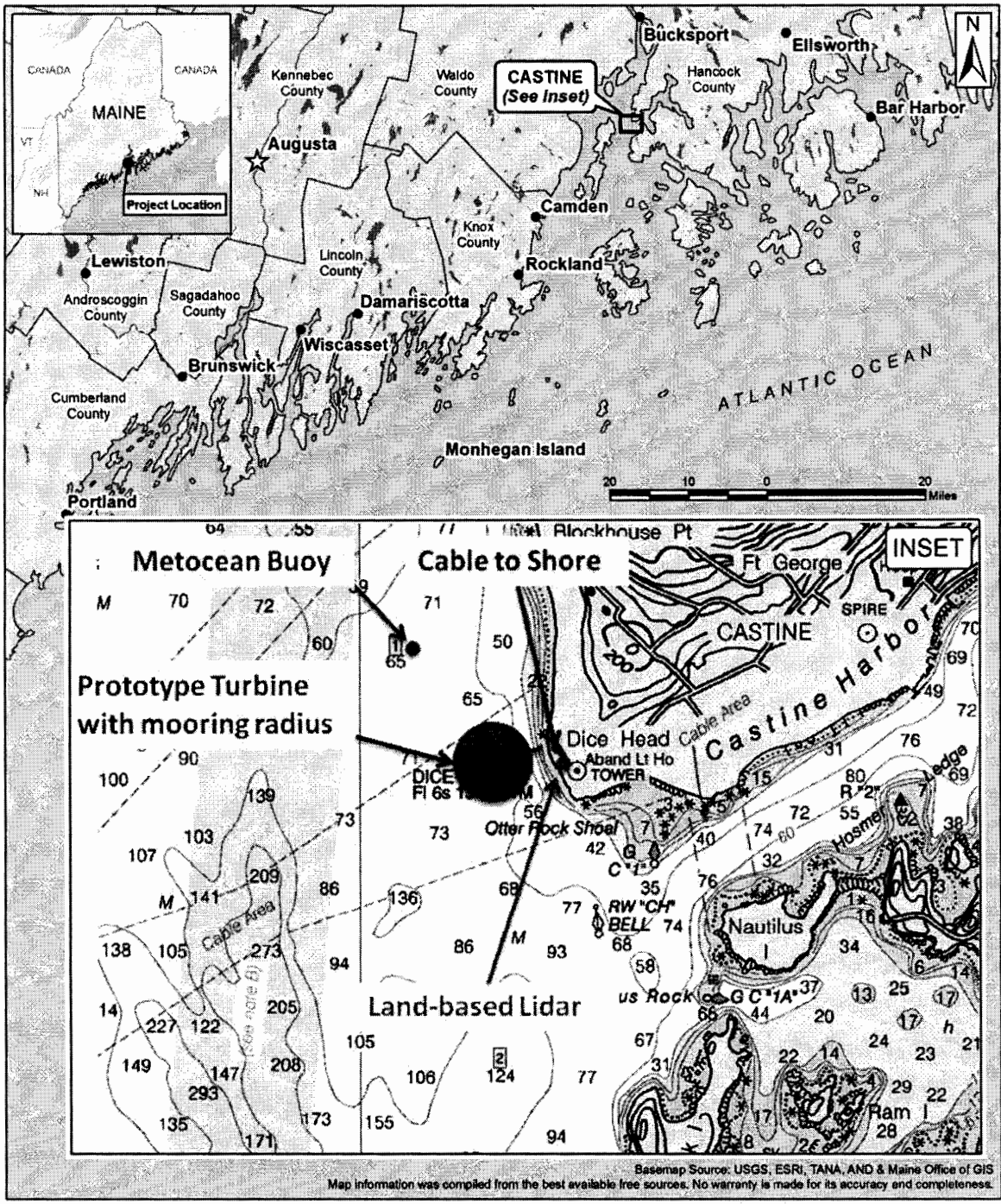
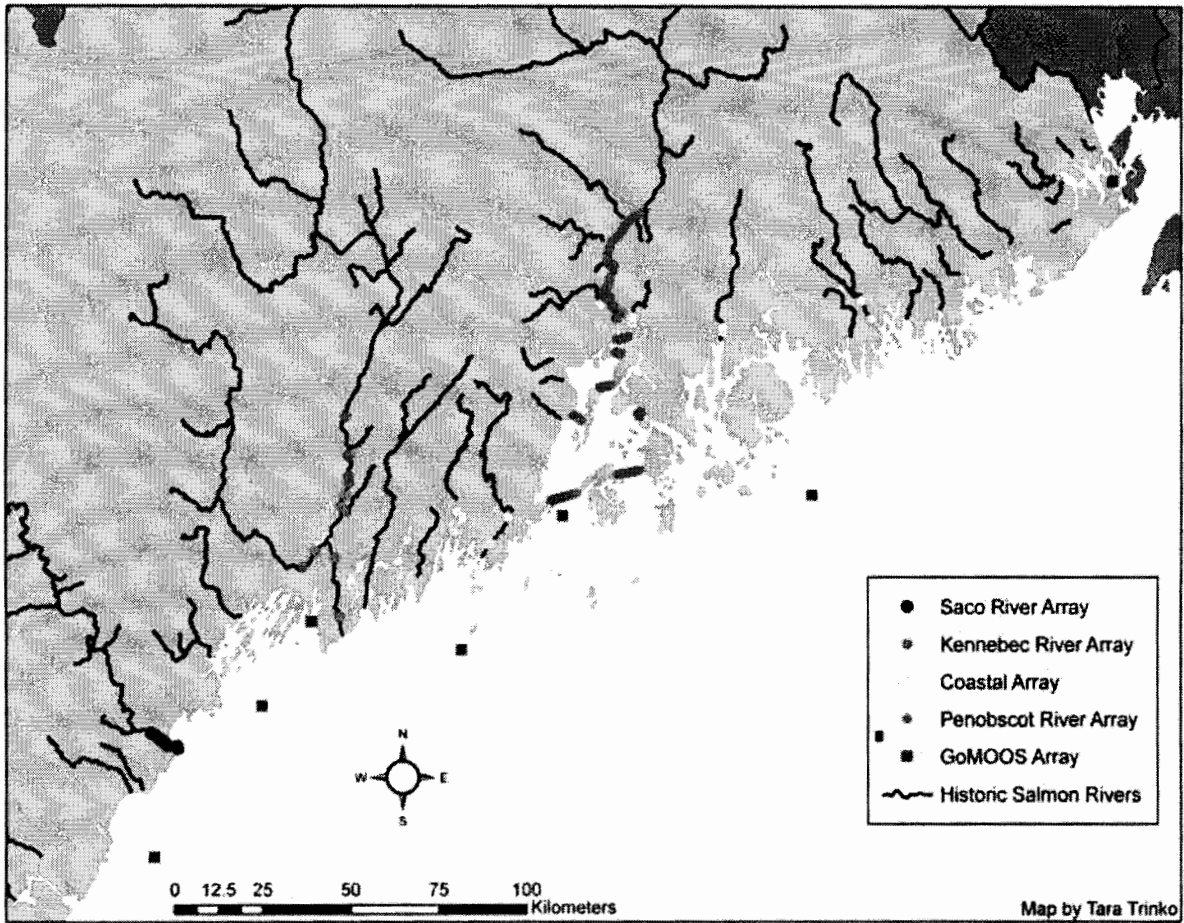
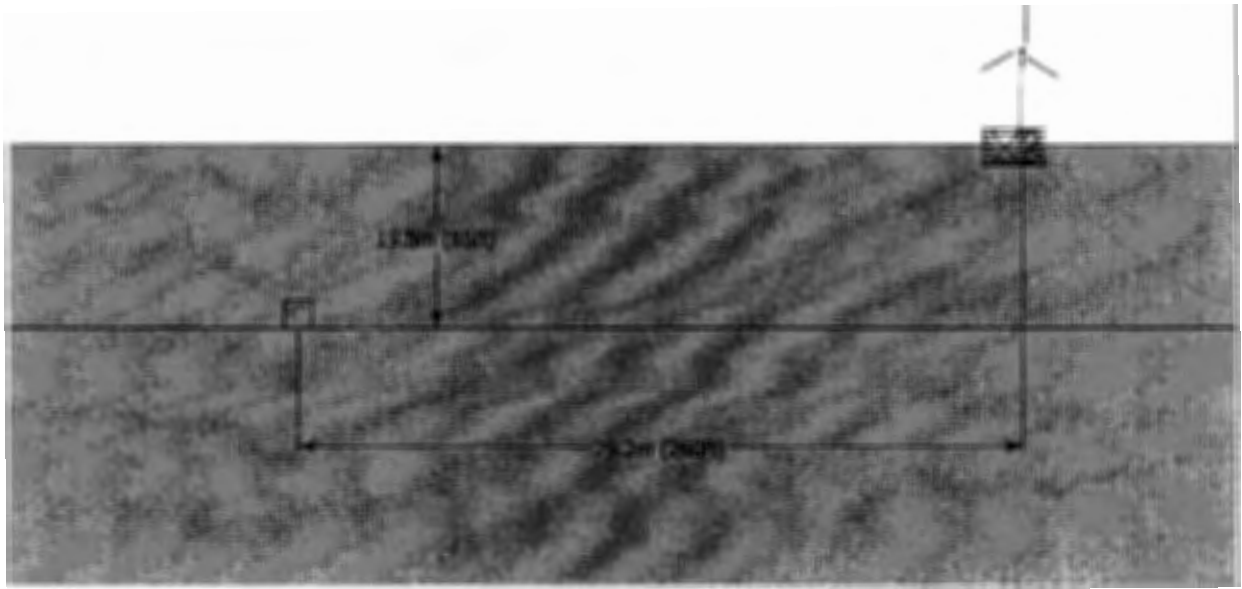


Figure 1. Map of Project Area





**Figure 2. Gulf of Maine Telemetry Array (each circle or square represents one receiver, gold circles represents Penobscot River Array)**



**Figure 3. Proposed mooring line design for anchoring floating platform**



# United States Department of the Interior



## FISH AND WILDLIFE SERVICE

Ecological Services  
Maine Field Office  
17 Godfrey Drive, Suite 2  
Orono, Maine 04473  
207/866-3344 Fax: 207/866-3351

March 7, 2013

Laura Margason  
Department of Energy  
Golden Field Office  
1617 Cole Boulevard  
Golden, Colorado 80401-3393

Dear Ms. Margason:

This letter responds to your January 16, 2013 letter requesting consultation pursuant to section 7 of the Endangered Species Act (ESA). This letter provides the U. S. Fish and Wildlife Service's (Service) response pursuant to section 7 of the ESA, as amended (16 U.S.C. 1531-1543), Bald and Golden Eagle Protection Act (16 U.S.C. 668-668d, 54 Stat. 250), and the Fish and Wildlife Coordination Act, as amended (16 U.S.C. 661-667d).

**Project Name/Location: University of Maine Testing of a Floating Offshore Wind Turbine Platform, Castine, Maine**

**Log Number: 05E1ME00-2012-I-0076**

The University of Maine intends to deploy a 20 kW Renewegy wind turbine on a floating platform in Castine, Maine. The turbine would measure about 41 feet from waterline to the hub, the rotor diameter would measure about 32 feet, and the total turbine height would be about 57 feet. The floating platform would be connected by cable to the Central Maine Power grid near Dyce's Head Road. The project would be deployed for up to four months in the spring and early summer of 2013. During the testing, the performance will be monitored in addition to monitoring birds (visual surveys and web camera observation), marine mammals (visual surveys), and bats (bat detectors). Similar pre-construction studies were conducted in 2012. Results of 2013 studies will be shared with the Service.

The Department of Energy (DOE) has acknowledged that some birds may collide with the turbine during the four-month deployment. However, the DOE has made a determination that the project is not likely to adversely affect the federally threatened piping plover (*Charadrius melodus*) and endangered roseate tern (*Sterna dougallii*) and has, therefore, requested the

Service's concurrence with this determination.

The Service has reviewed the Draft Supplemental Environmental Assessment (EA), which covers the activities at the Castine test site. We met with the University of Maine in early 2013. They provided additional information and answered questions on the EA as requested.

### **ESA Listed Species in the Action Area**

#### Piping plover

The piping plover (*Charadrius melodus*) nests on sand beaches on the coast of Maine. The closest nesting location is located at Reid State Park, which is located approximately 45 miles southwest of the Castine project area. It is unlikely that piping plovers from Maine nesting areas would be in the vicinity of Castine during the test period. However, approximately 250 pairs nest in eastern Canada and could be passing through the test area during the time that the turbine is deployed.

Little is known about the migration routes, altitude, flight patterns, and timing of migration of piping plovers migrating to eastern Canada. Northward migration from wintering grounds to breeding grounds occurs during late February, March, and early April. Piping plovers arrive in Nova Scotia from mid to late April. Southward migration begins as young plovers fledge in late July and extends through August, trailing off in early September. Plovers are generally believed to migrate in close proximity to the shoreline making shore stopovers lasting from a few days to a month at coastal locations during their migration. It is possible that as many as 500 northward migration flights by piping plovers may occur along the coast of Maine each spring. It is also possible that some or all eastern Canada plovers could migrate over water in the Gulf of Maine.

Risk to piping plovers from wind turbine generators sited near shore was assessed for another offshore wind generation project in New England in the Service's Biological Opinion for the Cape Wind Energy Project in Nantucket Sound, Massachusetts (2008). The Cape Wind project is proposed at a location that is two miles from the closest piping plover nesting beaches. The Cape Wind Biological Opinion reviewed and evaluated potential risk to piping plovers from other wind projects in eastern Canada and Massachusetts located near plover nesting beaches. None of these projects has caused detectable injury to piping plovers up to the time the Cape Wind Opinion was completed. Modeled collision rates for Cape Wind for migratory and resident piping plovers were estimated to be 0.18 collisions per year.

Impacts may vary with the specific size, number, and configuration of proposed wind turbine generators and site-specific factors such as juxtaposition of nesting and foraging habitats and weather patterns.

Because of the project location (the Castine test location is located far from nesting areas in Maine), the duration of the project testing (scheduled to be deployed for only four months), the absence of foraging habitat (there is little shorebird foraging habitat in the vicinity), and the overall size of the project (there is only a single turbine with small rotor swept area), we concur with the DOE that the project is not likely to adversely affect the threatened piping plover.

### Roseate tern

Roseate terns (*Sterna dougallii*) nest on islands off the coast of Maine. The closest nesting location is Seal Island in outer Penobscot Bay approximately 33 miles south of the project area. Roseate terns prefer to feed inshore, especially in shallow areas and shoals. During the breeding season, roseate terns forage over shallow coastal waters, sometimes near the colony and at other times at distances over 20 miles. They typically hover and dive from a height of 3.3 to 20 feet, but may do so from up to 40 feet. University of Maine preliminary studies documented few terns in the project area.

Risk to roseate terns from wind turbine generators sited near shore was assessed in the Service's Biological Opinion for the Cape Wind Energy Project in Nantucket Sound, Massachusetts (2008). This project is proposed at a location 19 miles from the closest roseate tern nesting colony. The Biological Opinion reviewed risk to terns from other wind projects in eastern Canada and Massachusetts located near tern colonies. Although none of the three wind projects reviewed have caused injury to roseate terns, other tern species, gulls, and passerine species have been killed. Pre-construction studies associated with the Cape Wind Project indicated the flight height of 90 percent of terns was less than 70 feet. Similar studies associated with the Massachusetts Maritime Academy single wind turbine documented that average flight height was 63 feet, and that terns avoided spinning rotor blades. However, ability to avoid wind turbines would be expected to be reduced during fog, rain, and low visibility conditions. Modeled collision rates were estimated to be four to five roseate terns killed per year at the Cape Wind Project.

Impacts of wind projects to terns will vary with the specific size, number, and configuration of proposed wind turbine generators and site-specific factors such as juxtaposition of nesting and foraging habitats and weather patterns. In Castine, the project is a single, small turbine, deployed for four months. The project is located 33 miles from the closest roseate tern nesting colony, which is farther than these birds normally travel to forage. Pre-construction data indicates the Castine area is not a concentrated foraging or migration staging area for terns. Therefore, the Service concurs with DOE that risk from a single wind turbine with small a rotor swept area at this location is not likely to adversely affect this species.

### Red knot

The red knot (*Calidris canutus*) is a candidate for Federal listing. Red knots use intertidal habitats as feeding areas and roost in Maine during their spring and fall migrations. Red knots regularly occur in Maine in late summer during their fall migration, but are very rare during the spring migration. Because of the small turbine size and timing of project deployment (deployed for four months during a time that red knots are largely absent from the State), the Service concurs that the project is not likely to adversely affect this species.

The University of Maine and DeepCWind Consortium's application to the Army Corps (February 13, 2013) indicates that the test turbine will be shut down if there is "adverse interaction (direct or potential harm) with ...any federally listed threatened or endangered

species...” The Service requests that the University of Maine immediately (within 24 hours) contact the Service if this scenario occurs.

## **Other Protected Species**

### Bald and Golden Eagles

As noted in our correspondence with the University of Maine, the closest known active bald eagle nest is located within about 2.5 miles of the project area. Nesting and non-nesting bald eagles would be expected to be in the vicinity of the project area during the test.

Risk to bald eagles at the test area is expected to be low because of the distance to the closest nesting site and the small size of the single turbine. The University of Maine proposed to conduct web camera surveillance and visual observations during the test of the turbine. Special circumstances (especially a local abundance of natural food or carrion) could attract eagles to the area. Although unlikely, eagles may be attracted to a small turbine as a perch site. Given that the blades on the test turbine could be moving at a high rate of speed, eagles may not see the spinning blades. An eagle was recently killed in this manner at a small turbine in Maryland. We request that bald eagle movements in the area be closely monitored on the web camera and by visual observations. If eagles are frequenting the area, we request that the University contact the Service to discuss ways to avoid or minimize risk of take. We request that all eagle encounters documented on the web camera be recorded and provided to the Service as part of the post-construction monitoring program. This would be valuable information and some of the first information of its kind collected in Maine.

### Migratory Birds and Bats

Small passerine birds, raptors, resident seabirds and waterfowl, and bats will all be present during the test period (March 1 to June 30). Preliminary studies by the University of Maine show a diverse assemblage of birds present at the site. Data on flight heights and behaviors suggest that the majority of birds observed in the test area fly above and below the turbine swept zone, but 19 percent were in the rotor swept zone. We have no experience with risk to birds from wind turbines placed on the water and urge the University of Maine to design studies to evaluate bird behavior in relation to an operating turbine. In particular, studies should be done to determine whether bird use in the test area increases or decreases in comparison to baseline studies. Behavioral studies should be done to determine how birds at greatest risk (those species most likely to fly in the rotor swept zone – gulls, loons, eagles, and some waterfowl) respond to the operating turbine; especially what percentage show avoidance behavior and what percentage fly through the rotating rotors. Any bird strikes should be reported to the Service’s, Maine Field Office by telephone at 207/866-3344, Extension 115 within 24 hours. The web camera should record bird activity continuously during all daylight hours including pre-dawn and dusk. Camera recordings should be analyzed promptly to document bird strikes and record, analyze, and document bird behavior. We request that all bird and bat encounters documented on the web camera be recorded and provided to the Service as part of the post-construction monitoring program.

The test period will occur during the spring migration when birds and bats are migrating along the coast at night. Preliminary studies by the University of Maine at the Castine test site did not evaluate night migration of passerine birds. Migration studies from other inland wind projects in Maine indicate that about 80 to 85 percent of the migration stream occurs above the turbine swept zone of large (approximately 3 mW) wind turbines. Thus, a relatively small proportion of migrating passerine birds would be expected to migrate at the 65 foot height of the test turbine. However, relatively little is known about coastal passerine bird migration. Large numbers of migrants accumulate and move along the coast because many species are reluctant to migrate over large expanses of open water.

The University of Maine interim report of radar studies of bird migration on Monhegan Island (Mizrahi 2011) show that some coastal migrating birds and bats would be expected to occur at less than 65 feet (height of the test turbine), especially in inclement weather (fog, low overcast). The data indicate 2 to 27 percent of targets flew below 50 meters in height on nights in July 2010. No radar measurements were taken during the spring migration on Monhegan Island that would coincide with the test period at Castine. The Service would appreciate receiving a final report for the radar studies conducted on Monhegan Island in 2010.

The University of Maine and DeepCWind Consortium's application to the Army Corps (February 13, 2013) indicates that to minimize risk to bats, cut-in speed will be approximately 3.5 meters per second, except during the time window of one hour before sunset and 2 hours after sunset, when cut-in speed will be approximately 5 meters per second. In addition, we recommend that the approximately 5 meters per second cut in speed be implemented throughout the night time hours to minimize risk to bats.

#### Proposed Project Visibility Lighting

Patterns of lighting (red versus white light, blinking or constant) will affect relative attraction to or avoidance of turbines by birds migrating at night. Our Service Land-Based Wind Energy Guidelines recommend that project developers: "Employ only red, or dual red and white strobe, strobe-like, or flashing lights, not steady burning lights, to meet Federal Aviation Administration (FAA) requirements for visibility lighting of wind turbines, permanent met towers, and communication towers. Only a portion of the turbines within the wind project should be lighted, and all pilot warning lights should fire synchronously."

Several authors have found that steady burning FAA obstruction lighting and some other types of lighting on mainly land-based tall structures (generally communication towers at heights of 1,000 feet) can attract or disorient night migrating birds, resulting in collisions with those structures. In a Michigan study, there was a 71 percent reduction in avian collision mortality at communication towers after red, continuous lights were extinguished and replaced with flashing or strobe lights,

A recent comprehensive review of research on the effects of lights from tall structures on night migrating birds concluded that the use of synchronously flashing LED lights significantly reduces avian mortality at tall structures.

We noticed that the test turbine on the University of Maine campus has a single continuously burning, red light. If it meets FAA requirements, we recommend an LED flashing red light or no light at all.

We appreciate your cooperation to date and look forward to continued coordination regarding this project. If you have any questions about our comments, please contact Mark McCollough, endangered species biologist, by email at *Mark\_McCollough@fws.gov* or by telephone at 207/866-3344 Extension 115.

Sincerely,

A handwritten signature in black ink, appearing to read 'L. A. Zicari', written in a cursive style.

Laury A. Zicari,  
Field Supervisor  
Maine Field Office





**Department of Energy**  
Golden Field Office  
1617 Cole Boulevard  
Golden, Colorado 80401-3393

## FINDING OF NO SIGNIFICANT IMPACT

### UNIVERSITY OF MAINE'S DEEPWATER OFFSHORE FLOATING WIND TURBINE TESTING AND DEMONSTRATION PROJECT – CASTINE

#### **DOE/EA-1792-S1**

AGENCY: U.S. Department of Energy, Office of Energy Efficiency and Renewable Energy

ACTION: Finding of No Significant Impact (FONSI)

SUMMARY: The U.S. Department of Energy (DOE) has completed a Supplemental Environmental Assessment (Supplemental EA) DOE/EA-1792-S1 for the University of Maine's (UMaine) Deepwater Offshore Floating Wind Turbine Testing and Demonstration Project - Castine. DOE prepared the Supplemental EA to evaluate the potential environmental impacts of providing funding to the UMaine for their proposed project offshore of Dyce Head in Castine, Hancock County, Maine (Castine site).

UMaine originally proposed to use federal funding to fabricate and temporarily deploy up to two, 1/3-scale turbines in Gulf of Maine, in waters south of Monhegan Island, Maine. DOE completed an earlier Environmental Assessment (DOE/EA-1792) and issued a FONSI specific to the Monhegan site in September 2011. UMaine has since proposed to downscale the size of the tower and turbine from 1/3 scale to 1/8 scale. Because of this proposed change to a smaller turbine, UMaine is proposing to deploy the tower and turbine at a more sheltered nearshore location just west of Castine, Maine prior to testing at the Monhegan site in the summer and fall of 2013. DOE determined that due to the addition of a new test site, a Supplemental EA was required prior to the authorization of federal funding<sup>1</sup>.

All discussions, analyses, and findings related to UMaine's proposed project, including applicant committed measures, for both the Monhegan and Castine sites, are documented in DOE/EA-1792 and DOE/EA-1792-S1. UMaine will implement the applicant committed measures listed in

---

<sup>1</sup> Prior to the issuance of this FONSI, DOE authorized UMaine to use a percentage of the federal funding for preliminary activities, which include preparing this Supplemental EA, conducting analyses, and agency consultations, and has approved similar deployment, testing, and retrieval activities at the Monhegan site. These activities are associated with the proposed project yet do not significantly impact the environment nor represent an irreversible or irretrievable commitment by the DOE in advance of this finding for UMaine's proposed testing at the Castine site.

Chapter 2.5 of DOE/EA-1792-S1 to minimize or avoid potential environmental effects to biological resources, ocean and land use, and cultural resources<sup>2</sup>. No DOE required mitigation was developed through public review of the draft Supplemental EA or interagency consultations. DOE/EA-1792 and DOE/EA-1792-S1 are hereby incorporated into this FONSI by reference.

Based on the analysis in the Supplemental EA, DOE has determined that the decision to authorize the expenditure of Congressionally directed federal funding by UMaine to proceed with the deployment, testing, and retrieval of one small-scale floating turbine at the Castine site, analyzed under DOE's Proposed Action and UMaine's proposed project, will not significantly affect the quality of the human and natural environment and that the preparation of an Environmental Impact Statement is not required. This finding and decision is based on the consideration of DOE's NEPA implementing regulations (10 CFR Part 1021) and the Council on Environmental Quality's criteria for significance (40 CFR 1508.27), both with regard to the context and the intensity of impacts analyzed in the Supplemental EA.

## **CONTEXT**

The UMaine is proposing to use Congressionally directed federal funding administered through DOE to deploy a 20-kW, 57-foot-tall wind turbine on a floating platform in state waters, 500 to 1,000 feet offshore of Dyce Head in Castine, Maine for a period of approximately four months in the spring and summer of 2013.

Because the effects of the project are limited to the local geographic area, short-term in duration, small-scale in nature, and the applicant committed measures listed in Chapter 2.5 of the final Supplemental EA are designed specifically to minimize or avoid potential environmental effects to biological resources, cultural resources, and ocean and land use; DOE has determined that there no direct, indirect, or cumulative effects of sufficient size or duration to be significant at the local, regional, or national level.

## **INTENSITY**

*Impacts that may be both beneficial and adverse:*

In the Supplemental EA, DOE considered and analyzed the beneficial and adverse impacts for the four-month turbine deployment at the Castine site. Due to the short term deployment and small size of the turbine and platform, the potential for adverse impacts to affected resources would be minimal. Applicant committed measures have been established to minimize potential adverse impacts to biological resources, cultural resources, and ocean and land use.

---

<sup>2</sup> The applicant committed measures listed in Chapter 2.5 of DOE/EA-1792-S1 will be incorporated and enforceable through the award terms and conditions. UMaine agrees to abide by the conditions, limitations, mitigation requirements, monitoring requirements and reporting responsibilities specified in DOE/EA-1792-S1.

As an innovative technological and research related renewable energy project, UMaine's project may result in the beneficial effects of exploration towards reductions in fossil fuel use, improvements in renewable energy production, and meeting the DOE Wind and Water Power Program's mission and goals for offshore wind advancement.

*The degree to which the proposed action affects public health or safety:*

In the Supplemental EA, DOE considered that there would be no disproportionately high or adverse human health or environmental effects related to the project and that it would not be a likely target for intentional destructive acts that could further affect public safety. In consultation with the US Coast Guard (USCG) Waterways Management Division, UMaine developed a navigation safety plan that would minimize impacts to public safety specific to commercial or recreational vessel traffic. The safety plan would include the use of best management practices during towing, deployment, and removal of the turbine and floating platform. Notice will be given to the Maine Marine Patrol and USCG to alert fishermen about towing operations and to advise for the removal of gear from the planned tow route to further minimize impacts to the public.

*Unique characteristics of the geographic area such as proximity to historic or cultural resources, park lands, prime farmlands, wetlands, wild and scenic rivers, or ecologically critical areas:*

Historic and cultural resources have been identified in the UMaine project area, and are described further in the Supplemental EA (Chapter 3.5). The proposed project site has no known unique or significant geographic resources and would avoid neighboring cultural resources identified in Chapter 3.5.

No other unique characteristics of the area would be altered or otherwise affected.

*The degree to which the effects on the quality of the human environment are likely to be highly controversial:*

Deployment of deepwater offshore floating wind turbines is relatively new to coastal Maine, but because of the small scale and short term of the deployment, this project has not been highly controversial. No public comments were received on the Draft Supplemental EA when it was available for public review, and the Town of Castine and Maine Maritime Academy have demonstrated their support of the project.

*The degree to which the possible effects on the human environment are highly uncertain or involve unique or unknown risks:*

Although some elements of this project involve relatively new technology, testing and scientific peer reviewed research on the technology are sufficient to support the findings and assessment of

effects in the Supplemental EA. The potential impacts to the human environment are fully analyzed and supported by previous projects, studies and publications, as referenced in the Supplemental EA. There is a low probability of highly uncertain effects or unique or unknown risks resulting from the proposed project.

*The degree to which the action may establish a precedent for future actions with significant effects or represents a decision in principle about a future consideration:*

Because of the nature of this research project, it could beneficially influence future development and deployment of deepwater, offshore wind turbines. However, the small scale and short term of the proposed project deployment do not represent significant effects nor do they represent a decision in principle about a future consideration.

*Whether the action is related to other actions with individually insignificant but cumulatively significant impacts:*

Operation of the small scale turbine might temporarily contribute to the cumulative mortality of individual birds and bats caused by this and other existing man-made structures in the region. However, it is anticipated that few birds or bats would be harmed by the project because the rotor diameter of the turbine would be small and the turbine would be deployed at the Castine site for only four months. The proposed action when evaluated together with other past, present, or reasonably foreseeable land disturbing activities in the area would not result in other cumulatively significant impacts at the local or regional scale.

*The degree to which the action may adversely affect districts, sites, highways, structures, or objects listed in or eligible for listing in the National Register of Historic Places or may cause loss or destruction of significant scientific, cultural, or historical resources:*

Surveys have been conducted by UMaine to ensure that shipwrecks and other underwater historic properties would not be disturbed by deployment of the turbine. The turbine would be located so that it would not be visible, or would appear small, from historic properties in the surrounding area. Therefore, deployment and retrieval of the floating platform would not adversely alter the viewshed from those properties or otherwise adversely affect districts, sites, or other properties listed or eligible for listing, or cause loss or destruction of significant scientific, cultural or historical resources. The Maine Historic Preservation Officer has concurred with this conclusion in a letter dated January 2, 2013. The Penobscot Indian Nation and the Aroostook Band of Micmacs each responded to DOE in transmittals dated November 29, 2012 that the project would not have impacts to any structure or site significant to those tribal nations.

*The degree to which the action may adversely affect an endangered or threatened species or its habitat that has been determined to be critical under the Endangered Species Act (ESA) of 1973:*

There would be no significant adverse impacts to threatened, endangered, or State of Maine sensitive species or associated habitat within the assessment areas. The National Marine Fisheries Service (NMFS) and the U.S. Fish and Wildlife Service (USFWS) were consulted in the development of the Supplemental EA. DOE consulted with each agency per the requirements set forth in Section 7 of the Endangered Species Act. In a letter dated February 20, 2013, NMFS concurred with DOE's findings that impacts from the proposed project to ESA listed species, essential fish habitat, and marine mammals would be insignificant or minimal. The USFWS also concurred with DOE findings, in a letter dated March 7, 2013, that the proposed project is not likely to adversely affect avian and bat species under their jurisdictional responsibilities.

*Whether the action threatens a violation of federal, state, or local law or requirements imposed for the protection of the environment:*

The proposed action does not violate any federal, state, or local law or requirement imposed for the protection of the environment. UMaine's commitment to obtain and comply with all appropriate federal, state, and local permits required for the project and to minimize potential impacts through the implementation of best management practices detailed in the Supplemental EA, shall be incorporated and enforceable through DOE's financial assistance agreement.

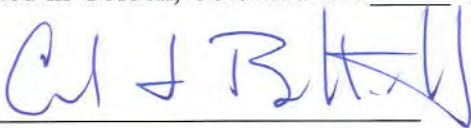
For questions about this FONSI or the Final Supplemental EA, please contact:

Laura A. Margason  
NEPA Document Manager  
U.S. Department of Energy  
Golden Field Office  
1617 Cole Boulevard  
Golden, Colorado 80401  
[GONEPA@go.doe.gov](mailto:GONEPA@go.doe.gov)

For information about the DOE NEPA process, please contact:

Office of NEPA Policy and Compliance  
U.S. Department of Energy  
1000 Independence Avenue, SW  
Washington, DC 20585  
<http://energy.gov/nepa/office-nepa-policy-and-compliance>

Issued in Golden, Colorado this 21<sup>st</sup> day of March 2013.



Carol J. Battershell  
Manager



# Deepwater Offshore Wind Test Site in Castine, Maine

## Fish and Wildlife Monitoring Plan

University of Maine

### Table of Contents

Table of Contents .....	1
List of Figures.....	3
List of Tables .....	3
Introduction.....	i
<b>1.0</b> Potential Impacts .....	1-1
1.1 Listed Benthic and Demersal Marine Species .....	1-1
1.2 Listed Marine Mammals.....	1-1
1.3 Listed Marine Fish .....	1-1
1.4 Listed Sea Turtles.....	1-2
1.5 Listed Avian Species .....	1-5
1.6 Avian Species .....	1-5
1.6.1 Direct Impact with Turbine Structure .....	1-6
1.6.2 Other Potential Impacts.....	1-6
1.7 Bat Species .....	1-6
1.8 Marine Mammals.....	1-7
1.8.1 Entanglement and Collision .....	1-8
1.8.2 Haul Out .....	1-9
1.8.3 Other Potential Impacts.....	1-9
1.9 Other Marine Resources: Benthic, Demersal, and Pelagic Species .....	1-9
1.9.1 Direct Effects to Marine Life from Deployment of the Anchors on the Seabed.....	1-9
1.9.2 Changes to Marine Community Composition .....	1-12
1.9.3 Artificial Reef.....	1-12
1.9.4 FAD Effect.....	1-14

**2.0** Monitoring Equipment, Methods, and Data Analysis .....2-1

    2.1 Listed Benthic and Demersal Marine Species .....2-1

    2.2 Listed Marine Mammals .....2-1

    2.3 Listed Marine Fish .....2-1

        2.3.1 Monitoring Equipment and Methods .....2-1

        2.3.2 Data Analysis and Distribution.....2-3

        2.3.3 Criteria for Assessing Adverse Impacts .....2-4

    2.4 Listed Sea Turtles .....2-4

    2.5 Listed Avian Species .....2-4

    2.6 Avian Species .....2-4

        2.6.1 Monitoring Equipment and Methods .....2-4

        2.6.2 Criteria for Assessing Adverse Impacts .....2-10

    2.7 Bat Species .....2-11

        2.7.1 Monitoring Equipment, Methods, and Analysis.....2-11

        2.7.2 Criteria for Assessing Adverse Impacts .....2-12

    2.8 Marine Mammals.....2-13

        2.8.1 Monitoring Equipment and Methods .....2-13

        2.8.2 Criteria for Assessing Adverse Impacts .....2-14

        2.8.3 Marine Resources: Video Assessment of Benthic Invertebrates and  
Demersal Species Based on Drop Camera Surveys -- Monitoring  
Equipment and Methods .....2-14

**3.0** Distribution of Data to MDEP .....3-1

**4.0** Detailed Implementation Schedule .....4-1

**5.0** Detailed Monitoring Schedule .....5-2

**6.0** Identifying & Implementing Remedial Measures .....6-1

**7.0** Ambient Noise, EMF, Noise from Project .....7-1

**8.0** Provisions for Filing an Annual Report .....8-1

**9.0** References .....9-1

# List of Figures

Figure i-1 Project Test Site Location Map ..... iii

Figure 1-1 Penobscot River and Bay receiver array (from Fernandes et al. 2010), each black circle represents one receiver. The orange rectangles identifies the area of interest. NOAA-Fisheries maintains 14 receivers across this channel annually. Receivers from West to East are numbered 1-14. .... 1-3

Figure 1-2 Representative biofouling on Gulf of Maine Oceanographic Buoys. Buoy E01 summer fouling shown on left and Buoy E01 winter fouling shown on right ..... 1-13

Figure 2-1 Map of the coast of Maine depicting locations of acoustic receivers..... 2-2

Figure 2-2 Locations of most recent bald eagle nest sites in project vicinity (210B and 210D)..... 2-6

# List of Tables

Table 1-1 Available number of tags for detection at the Dice Head array in each year analyzed.. 1-4

Table 1-2 The numbers of tags detected at the Dice Head array in each year analyzed. Percentages are the proportion of those available that were detected on this part of the array. .... 1-4

Table 1-3 Listed Avian Species. Source: Maine Department of Inland Fisheries and Wildlife, US Fish & Wildlife Service ..... 1-5

Table 2-1 Most common bird species observed offshore of Castine. .... 2-5

Table 2-2 Example of most common codes used to document behaviors observed during transects (Gould & Forsell, 1989)..... 2-10

Table 7-1 Underwater sound pressure levels for various types of vessels. .... 7-1





# University of Maine Deepwater Offshore Wind Test Site at Castine, ME

## Fish and Wildlife Monitoring Plan

### Introduction

Requirements under 38 MRSA §480-HH provide a framework within which the University of Maine (UMaine) and DeepCwind Consortium are applying for a permit from Maine Department of Environmental Protection (MDEP) to temporarily deploy one one-eighth scale floating wind turbine prototypes. Part E under Section 3 (Application Requirements) identifies requirements for a fish and wildlife monitoring plan for threatened and endangered species (both state and federally listed), avian species, bats, marine mammals, and other marine resources, which must be prepared in consultation with resource agencies. To address these requirements, this plan includes the following sections:

- Section 1** .....Potential impacts
- Section 2** .....Description of monitoring equipment, methods and data analysis
- Section 3** .....Distribution of data to MDEP
- Section 4** .....Detailed implementation schedule and quarterly reporting to MDEP
- Section 5** .....Detailed monitoring schedule
- Section 6** .....Provisions for identifying and implementing remedial measures if adverse changes in fish/wildlife behavior are identified
- Section 7** .....Description of methods to monitor noise and electronic fields
- Section 8** .....Provisions for annual reporting of monitoring results

Section 1 addresses potential impacts for each species group related to: physical interaction with turbines, platforms, cables and anchors; alteration of benthic, demersal, and pelagic habitats and species that rely on them; and pollution effects – such as solvents, construction materials, hydraulic and other fluids. Acoustic effects of turbines and other system components are addressed in Section 7.

The environmental monitoring research is designed to deliver information about species of conservation or commercial concern, as well as provide new understanding about the

spectrum of potential environmental impacts of deep-water offshore wind developments on marine species, habitats, and ecosystems in the Gulf of Maine. The assessment of potential impacts and design of an appropriate, effective monitoring plan are based on a review of existing information and initial field studies, as presented in the accompanying Commercial Fishing and Marine Resources Report prepared by UMaine.

The Fish and Wildlife Monitoring Plan includes survey methods for the following groups:

- Benthic and demersal marine species: Before-After, Control-Impact (BACI) surveys of the test site(s) and control site(s) using a Remotely Operated Vehicle (ROV). Telemetry to identify tagged fish species presence and movement within the test site area.
- Pelagic marine resources: Telemetry to identify tagged fish species presence and movement within the test site area.
- Marine mammals: Assessment of the noise produced by the turbine, platform and anchoring system from the perspective of marine mammal impacts; opportunistic and dedicated visual surveys for marine mammals in association with other field work.
- Birds and bats: Opportunistic and dedicated visual surveys for birds in the test site area. Opportunistic visual identification of targets to ground truth radar. Passive acoustic monitoring for bats. Ongoing interpretation of bird and bat data collected at and near Castine, ME within the context of data collected through other research projects throughout the region.

For species groups that can be effectively studied through BACI methods, monitoring is designed to assess pre-deployment conditions during March-June 2012, as well as conditions during the same seasonal window (March-June) during the year(s) of turbine deployment, currently proposed for 2012 and 2013.

A location map of the project test site is presented in Figure i-1. For specific turbine location and layout information, refer to the Site Plan section of the U.S. Army Corps (USACE) Permit application.

The applicant, the University of Maine, has developed this monitoring plan based on contributions from multiple individual researchers and organizations. In addition, organizations on the project permitting team supporting the University of Maine's application have contributed to this plan, including HDR/DTA and Kleinschmidt Associates. Dr. Damian Brady, University of Maine, is the leader of the environmental monitoring team and is ultimately responsible for design and implementation of appropriate, effective monitoring for the project.

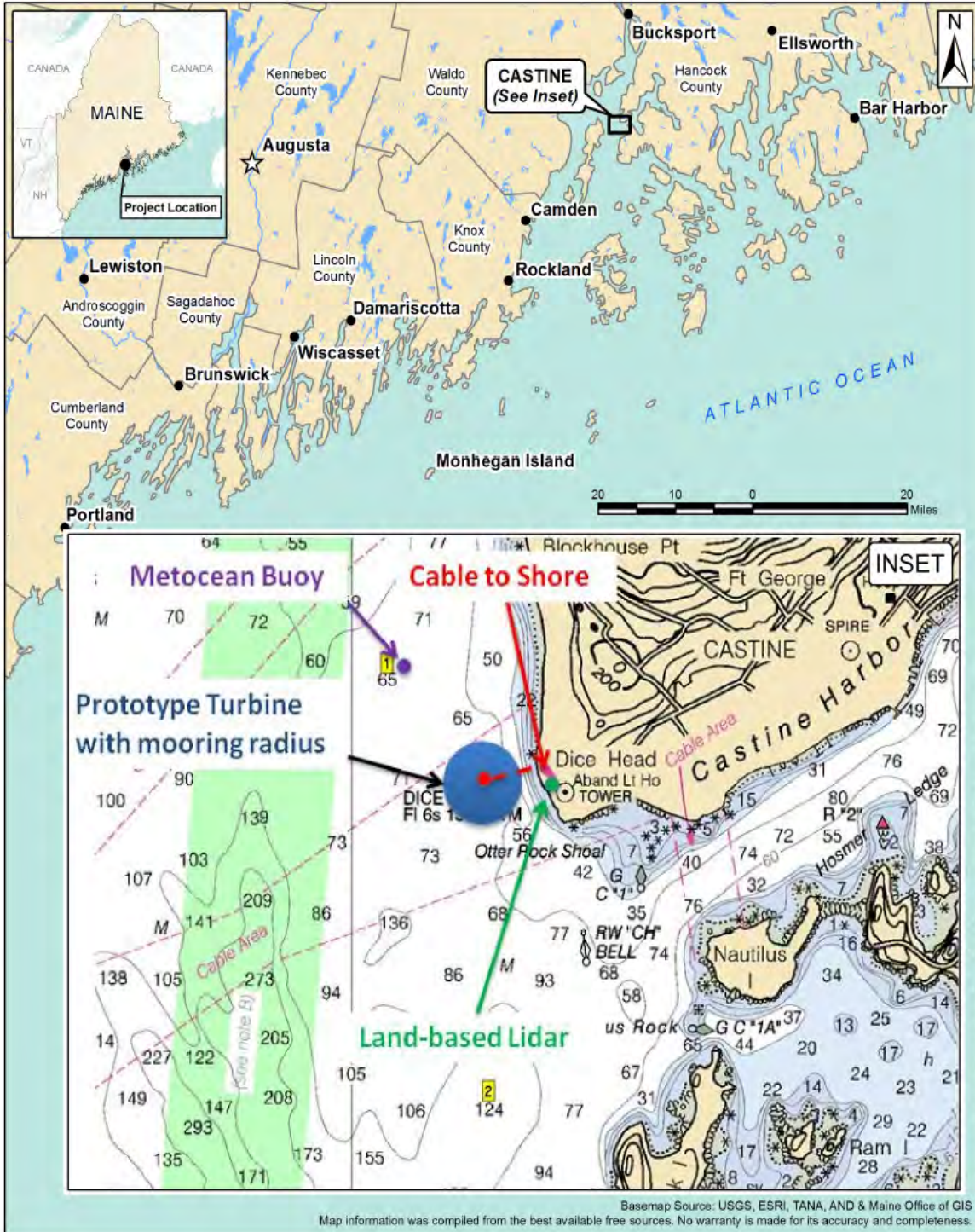


Figure i-1 Project Test Site Location Map

## 1.0 Potential Impacts

### 1.1 LISTED BENTHIC AND DEMERSAL MARINE SPECIES

No benthic or demersal marine species are federally or state listed, with the exception of diadromous fishes, addressed in Section 1.3. General information on and pelagic marine resources is presented in Section 1.9.

### 1.2 LISTED MARINE MAMMALS

Six large whale species are federally or state listed: humpback, right, fin, sei, blue and sperm whale. Potential for interactions with platform and anchoring systems are addressed under Section 1.8 Marine Mammals, below. Monitoring plans are presented in Section 2.8 Marine Mammals and Section 7.0 Ambient Noise.

### 1.3 LISTED MARINE FISH

Two marine fishes are federally or state listed: Atlantic salmon and shortnose sturgeon. In addition, Atlantic sturgeon was recently listed.

No specific literature exists on the interaction of salmon or sturgeon with offshore platforms or anchoring systems. However, some literature exists on the impacts of pile driving and other in-river construction activities, e.g., dredging (Hastings 1983; Zydlewski 2009). Sub-adult and adult shortnose sturgeon were not shown to be substantially affected in either of these studies. Although construction activities and platform operations could change the local environment to result in modified movement patterns of individuals, these impacts are expected to be less severe than would result from pile driving or dredging.

All three species, shortnose sturgeon, Atlantic sturgeon, and Atlantic salmon, use the Gulf of Maine region as a migratory pathway. NOAA's National Marine Fisheries Service deploys a series of receivers near Dice Head Lighthouse that can be used to assess habitat use.

During migration, individuals would be moving through the area of the proposed project and not be expected to reside for any long period. It is expected that impacts would be most detrimental during deployment of anchors and turbine platforms, but even then injury to mobile fishes seems unlikely. This would involve installation of three sailboat anchors and should have a very limited impact on the migrant populations. Effects of the anchors on other marine resources are discussed in Section 1-9. The floating turbine platforms may be

retrieved during the early summer, however impacts to mobile fish species during this process should be minimal.

NOAA Fisheries, USGS, and the University of Maine have been deploying and maintaining an array of acoustic receivers in the Penobscot River since 2005 (Figure 1-1). Receivers detect, decode, and record individual transmitters that are deployed on or in aquatic organisms. Additional receivers have been added to this array by other groups (Maine Department of Marine Resources and University of New England) to make a comprehensive array of tag detection units in the Gulf of Maine. Annually, different fish species are tagged in the Penobscot River to determine their movement patterns and survival through the river, estuary, bay system. Since 2006 the following endangered species have been tagged with acoustic transmitters that can be detected on the array: Atlantic salmon, Atlantic sturgeon, and shortnose sturgeon have been regularly tagged.

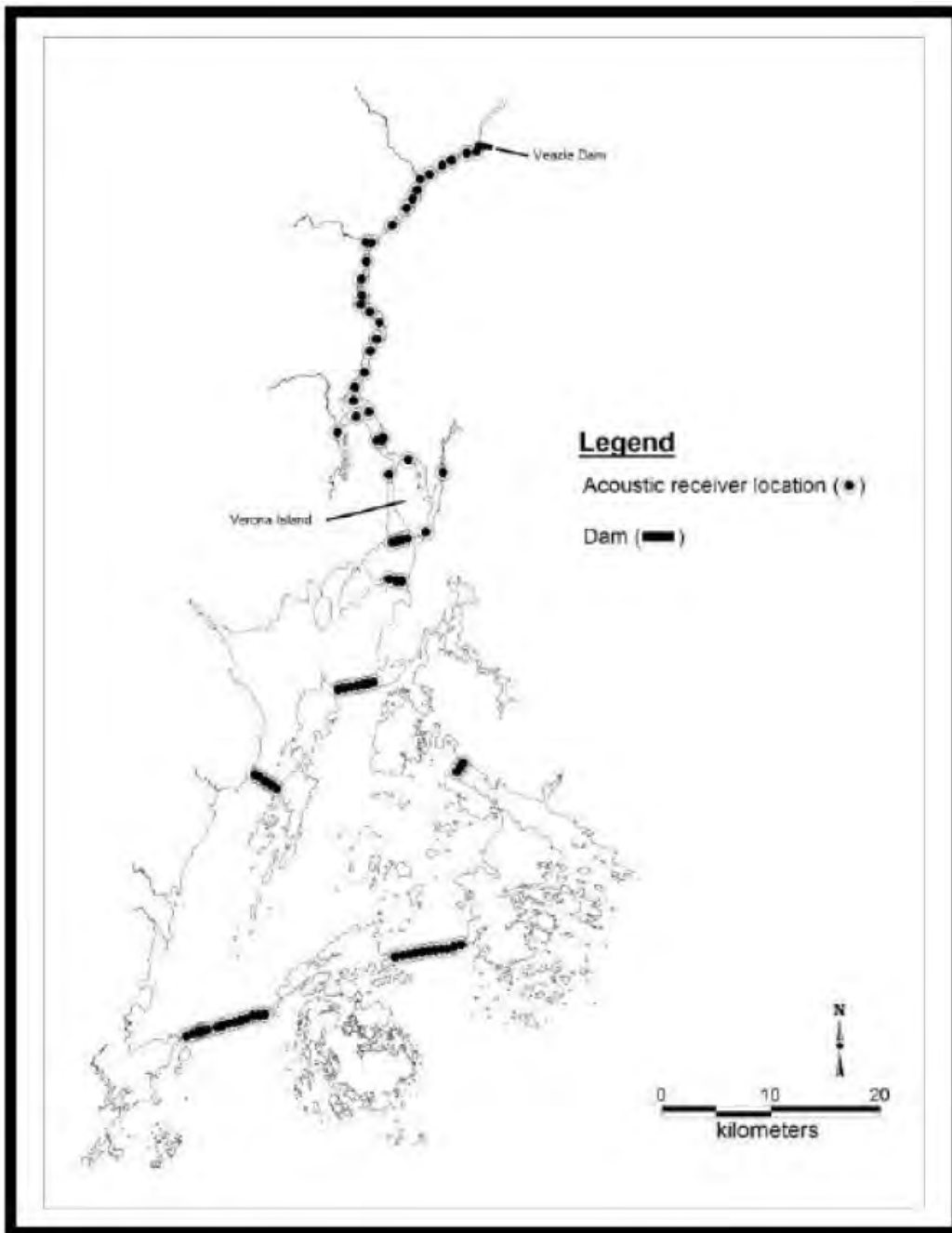
In each year the number of individual tagged fish available for detection changes (Table 1-1). Between 200 and 400 Atlantic salmon, 15-25 Atlantic sturgeon and 25-40 shortnose sturgeon were tagged in the Penobscot River system and available for detection at the Dice Head array.

All three species were detected on the Dice Head array in each year, some in higher proportion than others (Table 1-2). Movements through the array were seasonal with Atlantic salmon movements focused in May; Atlantic sturgeon movements throughout the year but focused in May and October; shortnose sturgeon movements occurring from May – July. Some shortnose sturgeon had transmitters that also provided information on depth of movement. For the five individuals detected in 2009 their average depth of movement was  $34.6 \pm 4.4$  (mean  $\pm$  SD) feet. The channel in this reach of the bay can be up to 120 feet deep.

#### 1.4 LISTED SEA TURTLES

All sea turtles are protected under the ESA. Although sea turtle sightings are uncommon in the Gulf of Maine (and even less common in the estuaries), leatherback (*Dermochelys coriacea*), loggerhead (*Caretta caretta*), and Atlantic Ridley (Kemp's Ridley) (*Lepidochelys kempi*) sea turtles are known to occur there. The leatherback and Atlantic Ridley are endangered and the loggerhead is threatened under the ESA. The proposed project is not located within any critical habitat for marine turtles, and no turtles were observed during the boat-based visual surveys in the Castine Test Site vicinity over 17 weekly visual surveys from March through June 2012 (Kennedy 2012).

Sea turtles breathe air, so they remain at or near the sea surface most of the time. Although turtles can become entangled in nets and fishing line, none of the structures proposed for the project (anchors, anchor lines, platform, turbines) is known to pose a threat to this group. We know of no records of sea turtles in the proposed deployment area, nor are floating structures known to be a hazard for this group.



*Figure 1-1 Penobscot River and Bay receiver array (from Fernandes et al. 2010), each black circle represents one receiver. The rectangles identifies the area of interest. NOAA-Fisheries maintains 14 receivers across this channel annually. Receivers from West to East are numbered 1-14.*

**Table 1-1** Available number of tags for detection at the Dice Head array in each year analyzed.

Year	Atlantic salmon	Atlantic sturgeon	Shortnose sturgeon
2009	245	21	26
2010	392	18	28
2011	380	24	38

**Table 1-2** The numbers of tags detected at the Dice Head array in each year analyzed. Percentages are the proportion of those available that were detected on this part of the array.

Year	Atlantic salmon	Atlantic sturgeon	Shortnose sturgeon
2009	73 (30%)	19 (90%)	5 (19%)
2010	99 (25%)	18 (100%)	2 (7%)
2011	82 (22%)	15 (63%)	5 (13%)

**1.5 LISTED AVIAN SPECIES**

Table 1-3 includes avian species that are listed as threatened or endangered, as well as species considered of particular importance and concern by the State of Maine. All of these listed species may occur in the area of the proposed project. Potential impacts on listed avian species are addressed in Section 1.6 - Avian Species.

**Table 1-3** *Listed Avian Species. Source: Maine Department of Inland Fisheries and Wildlife, US Fish & Wildlife Service*

Listed as Federal and/or State of Maine Endangered or Threatened	Listed as Maine Species of Special Concern	Important Neotropical Migrant Species in Maine
Harlequin Duck	Leach’s Storm Petrel	Yellow-bellied Sapsucker
Bald Eagle	Great Cormorant	Veery
Golden Eagle	Least Bittern	Northern Parula
Peregrine Falcon	Black-crowned Night Heron	Chestnut-sided Warbler
Piping Plover	Barrow’s Goldeneye	Cape May Warbler
Upland Sandpiper	Cooper’s Hawk	Black-throated Blue Warbler
Roseate Tern	Northern Goshawk	Blackburnian Warbler
Arctic Tern	American Coot	Black and White Warbler
Least Tern	Red-necked phalarope	American Redstart
Black Tern	Laughing Gull	Ovenbird
Atlantic Puffin	Common Tern	Canada Warbler
Razorbill	Short-eared Owl	Rose-breasted Grosbeak
American Pipit	Olive-sided Flycatcher	
Grasshopper Sparrow	Loggerhead Shrike	
	Vesper Sparrow	
	Eastern Meadowlark	
	Rusty Blackbird	
	Orchard Oriole	

**1.6 AVIAN SPECIES**

The USFWS created a list of species requiring special conservation action and awareness: the Birds of Conservation Concern 2008 (USFWS 2008). Species of Conservation Concern counted in the project area included 18 red-throated loons (*Gavia stellata*), three bald eagles (*Haliaeetus leucocephalus*), one peregrine falcon (*Falco peregrines*), two razorbills (*Alca torda*), and one unidentified tern. The most recent bald eagle nest sites close to the test site are approximately 2.5 miles south of the test site on Brooks Island.



### 1.6.1 Direct Impact with Turbine Structure

The operation of the proposed project would introduce static and moving above-water components at the site, potentially within the flyway of birds and bats. During project operation, flying vertebrates (migrating birds, foraging birds, and bats) could be at risk of colliding with the turbine. As described below, the probability of birds and bats being killed or injured by the 1/8-scale turbine is low.

While varying with location, the national average of collision-related mortality for birds at land-based commercial wind farms is low, less than three birds per full-size turbine per year (Erickson et al. 2001). In addition, the Castine turbine would be lit at night with a flashing sequence for the purposes of navigational safety; some bird species such as petrels and migrating songbirds can be attracted to light during nighttime and diurnal conditions with poor visibility (UMaine 2011), which could put such species at a higher risk of collision with the turbine.

Bat fatalities at wind energy facilities appear to be highest along forested ridgetops in the eastern U.S. and lowest in relatively open landscapes in the midwestern and western states (Kunz et al. 2007). A consistent theme in most of the mortality monitoring studies conducted at utility-scale wind farms has been the predominance of migratory, tree-roosting species among the fatalities. Of them, nearly 75 percent were tree-roosting, eastern red bats, hoary bats, and tree cavity-dwelling silver-haired bats (Kunz et al. 2007).

The proposed turbine would have a rotor sweep zone ranging from approximately 25 feet to 57 feet above the water surface (actual rotor diameter of 31.5 feet). Of the 456 flying birds observed during the 17 surveys UMaine conducted between March through the end of June 2012, the majority flew under 16.4 feet (5 meters) and 40% flew at 3.2 feet (1 meter) high. Approximately 19% flew between heights of the rotor sweep zone (Figure 1-2). Herring gulls, ring-billed gulls (*Larus delawarensis*), and common loons were the most common species to be flying in the height range of the rotor (Kennedy 2012).

### 1.6.2 Other Potential Impacts

Any leaking of lubricating oils (e.g., hydraulic fluid) pose risk to birds directly through coating and contamination of feathers, which can cause loss of buoyancy and thermoregulation, and toxicity through ingestion. Indirectly, leaking can affect birds by altering the local food supply, but the small quantity of lubricants used for wind turbines is unlikely to be the source of chronic leaks large enough to have such indirect effects. Proposed methods for on-site management of fuels, lubricants and other materials will be addressed in the USACE Permit application.

## 1.7 BAT SPECIES

Eight species of bats occur in Maine, based upon their normal geographical range. These are the little brown bat (*Myotis lucifugus*), northern long-eared bat, (*M. septentrionalis*), eastern small-footed bat (*M. leibii*), silver-haired bat (*Lasionycteris noctivagans*), tri-colored bat (*Perimyotis subflavus*), big brown bat (*Eptesicus fuscus*), eastern red bat (*Lasiurus borealis*), and hoary bat (*Lasiurus cinereus*) (DeGraaf and Yamasaki 2001). The red bat, hoary bat, and silver-haired bat are migratory in the region, while the other species seek hibernacula in natural and man-

made structures, including buildings, tree cavities, caves, and rock crevasses (UMaine 2011). None of these species is listed under the ESA.

Bats become active in early spring when night flying insects emerge (Maine Board of Pesticides Control, Undated). To understand the composition of the bat assemblage during the later period of the deployment, surveys were conducted from the tower of the Dyce Head Lighthouse in Castine, the nearest feasible monitoring location to the site at which the test turbine is to be deployed. An acoustic detector was deployed on the tower of the Dyce Head Lighthouse on May 22, 2012, and operated nightly through July 10, 2012. A total of 797 bat call sequences were recorded during this period. Between 0 and 107 call sequences were recorded per night, with an overall activity level of 15.9 call sequences per detector-night. Bats were detected during 42 out of 50 surveyed nights (84 percent). Of the 797 recorded call sequences, 422 (53 percent) were identified to species or guild. Call fragments that were too short to be identified were classified as either high frequency or low frequency “unknown” (Stantec 2012). Results by species are as follows:

- 235 calls - big brown bat/silver-haired bat guild, including the big brown bat and silver-haired bat;
- 153 calls - *Myotis* genus;
- 19 calls - eastern red bats;
- 15 calls - hoary bats;
- 228 calls – high frequency unknown (likely includes eastern red bats, tri-colored bats, and *Myotis* species); and
- 147 call – low frequency unknown (likely includes big brown, silver-haired, and hoary bats) (Stantec 2012).

## 1.8 MARINE MAMMALS

The Gulf of Maine is host to numerous marine mammals including large and small whale species, and three species of seals. Six ESA-listed whales that have the potential to occur in the Gulf of Maine are North Atlantic right (*Eubalaena glacialis*), fin (*Balaenoptera physalus*), humpback (*Megaptera novaeangliae*), sei (*B. borealis*), blue (*B. Musculus*), and sperm (*Physeter macrocephalus*) whales. None of these species were observed during the 17 boat-based visual surveys UMaine conducted from March through June 2012 in the project vicinity (Kennedy 2012), nor are they expected to occur near shore in the upper portion of Penobscot Bay where the project is located. The project is not located within right whale critical habitat. Critical habitat has not been designated for the other five ESA-listed whale species.

During the 2012 boat-based visual surveys, UMaine observers counted 66 harbor seal (*Phoca vitulina*), one grey seal (*Halichoerus grypus*), and 34 harbor porpoise (*Phocoena phocoena*). Individuals of these three marine mammal species combined, were found at a density of 0.38 animals/km<sup>2</sup> (Kennedy 2012). North Atlantic right, humpback, minke (*B. acutorostrata*), and fin whales do occur in the outer Penobscot Bay and Gulf of Maine (UMaine 2008), but large whale species are not be expected to occur in the project area because it is located in the upper portion of Penobscot Bay.

### 1.8.1 Entanglement and Collision

This section evaluates the potential that marine mammals may become entangled, or collide, with the project mooring lines. Marine mammals in the Gulf of Maine are exposed to a variety of anthropogenic structures in the water column, including moored navigation aids and oceanographic buoys, anchored and moving ships, and lobster buoys. Moored vessels are common in harbors, such as Castine Harbor, and other locations along the Maine coast. During the UMaine biological surveys, researchers documented densities of lobster buoys as high as 9.9 buoys/km<sup>2</sup> in the project vicinity (Kennedy 2012). As discussed in Section 3.2.1, during surveys in the project vicinity, one gray seal, 66 harbor seals, and 34 harbor porpoise were observed. No sea turtles or large whales were observed (Kennedy 2012).

Marine mammals have evolved to avoid colliding with natural features as well as to avoid predators. For example, many toothed whales have a well-developed ability to echolocate and avoid structures in the water (Akamatsu et al. 2005). In a study of finless porpoise (*Neophocaena phocaenoides*), Akamatsu et al. (2005) found that this species inspected ahead a distance of up to 250 feet and swam less than 65 feet without using sonar. Researchers concluded that the distance inspected was sufficient to provide awareness of any risk ahead (Akamatsu et al. 2005). Seals have well-adapted underwater vision (Schusterman and Balliet 1970) and use their vibrissae to detect changes in pressure or vibrations in the water (Dehnhardt et al. 2001; Mills and Renouf 1986). Because of the acute sensory capabilities of toothed whales (echolocation) and the small size and maneuverability of seals, it is expected that the marine mammal species that occur in the project area would be able to detect and avoid underwater moorings.

There is generally more uncertainty regarding the ability of baleen whales, which do not use sonar, to avoid mooring lines. However, whale collisions with moored ships and buoys are uncommon. Large whales are not expected to occur in the project area, which is located in upper Penobscot Bay 500 to 1,000 feet offshore.

In addition, the mass/buoyancy of the platform and mass of the anchors is expected to create substantial tension in the mooring lines. These factors would prevent the formation of loops around a passing whale. The potential for heavy mooring gear combined with relatively taut mooring lines to entangle whales has been shown to be negligible (Wursig and Gaily 2002).

The small size of the project relative to surrounding open ocean area of Penobscot Bay, the fact that the platform would be temporarily deployed for up to four months and that large whale presence at the project area is unlikely, further reduces the likelihood of an adverse effect to marine mammals, including ESA-listed species. A slight increase in vessel traffic associated with the project installation and maintenance would be negligible for this small scale and temporary project. While the potential for a vessel and marine mammal interaction is unlikely, NMFS marine mammal avoidance procedures would be implemented in the event that a marine mammal is encountered by a deployment or maintenance vessel.

In conclusion, for the reasons stated, the potential that marine mammals will become entangled or collide with the project, or collide with service vessels is negligible.

**1.8.2 Haul Out**

Seals are known to haul out on nearly any floating platform. Thus, the most common direct interaction between marine mammals and the turbines is likely to involve seals using new solid structures above the water line. Hauling out on a turbine platform is unlikely to injure the seal; rather, it is more likely that seals could become a nuisance to operations and maintenance.

Design specifications for the test turbines include deterrents to use of the structures by marine mammals. Specifically, platforms or structures will be designed to discourage use by seals for haul-out by avoiding horizontal structures near the waterline. The Tension Leg Platform does not include any horizontal structures close enough to the waterline for seal haul-out to be feasible.

**1.8.3 Other Potential Impacts**

Increase in vessel traffic associated with the project installation and maintenance for this temporary project will be mostly related to approximately weekly site visits for combined monitoring and maintenance purposes. While the potential for a vessel and marine mammal interaction is unlikely, NMFS marine mammal avoidance procedures would be implemented in the event that a marine mammal is encountered by a construction or maintenance vessel.

**1.9 OTHER MARINE RESOURCES: BENTHIC, DEMERSAL, AND PELAGIC SPECIES****1.9.1 Direct Effects to Marine Life from Deployment of the Anchors on the Seabed**

Potential effects resulting from the deployment of the floating turbine platform and subsea cable to habitat on the seabed and in the water column include: 1) direct effects on marine life from deployment on and removal from the seabed of the anchors and subsea cable and 2) changes to the marine community composition at the deployment site (e.g., use patterns, attraction, aversion).

Some benthos would be disturbed from the deployment of the four anchors and the subsea cable on, and their removal from, the seabed. Specifically, the placement of anchors and the cable could cover or injure slow-moving or immobile benthic organisms, such as bivalves, sand dollars, and worms directly beneath the anchors. Removal of the anchors and cable could also potentially harm slow-moving or immobile benthic organisms. UMaine will use embedment anchors because this anchor type minimizes impacts to the seafloor compared to other anchor designs, works with the bottom conditions at the proposed site, and is easily removed at project completion. The combined footprint of the four anchors would be at most 64 ft<sup>2</sup>. The footprint of the conduit containing the subsea cable, having a diameter of 2½ inches, plus associated strip weights, would also be very small. Mobile invertebrates and fish species would likely move away from the immediate vicinity of the project during

deployment and removal activities. Therefore, the placement and removal of the four anchors and the subsea cable would cause negligible effect to benthic organisms.

The presence of floating turbine platforms in the water column and floating above the water may result in temporary altered use by marine life and a resulting temporary change in the marine community composition in the following ways:

- Artificial reef effect<sup>1</sup> - The anchors, mooring lines, below-water portions of the turbine platform, and subsea cable could provide habitat for biofouling organisms and structure-oriented fish.
- Fish aggregation device (FAD) effect – Fish are also known to aggregate around floating objects (Nelson 2003), which is often called a FAD effect.
- Bird roosting/seal haul out – Birds may roost on the above-water portions of the platform, and seals are known to haul out on nearly any accessible floating platform.
- Avoidance of the project area by resident and migratory species – For commercial-scale offshore wind projects, concerns have been raised that resident or migratory species might avoid wind farms.

Because the anchors are small (having similar dimensions to anchors used by large sailing vessels in Castine Harbor and along the Maine coast), as is the footprint of the cable conduit and associated strip anchors, and because the deployment is temporary, lasting only four months or less, any such effects to the marine community would be negligible. As was concluded in the Monhegan FONSI (DOE 2011) for larger 1/3-scale floating turbine platforms, the degree to which the project would change the habitat or the marine community in the deployment area is expected to be negligible, and would not affect populations of species that use the area, because of:

- The small spatial scale of the project (revised to be even smaller – only one 1/8-scale platform, associated moorings, and a subsea cable deployed on the surface of the seabed);
- The deployment of the project in an existing subsea cable ROW;
- The short duration of installation activities - the short period of time required for deployment and removal minimizes the avoidance of the area of marine species; and
- The short duration of the project - biofouling organisms would have only four months to grow before the platform would be removed, which minimizes the artificial reef effect of the platform.

In addition, design measures would be implemented to minimize bird attraction and roosting (e.g., the turbine will not have external ladders or other structures that would allow birds to perch near the turbine blades) and to prevent seal haul out (the platform deck will be raised several feet above the water level).

---

<sup>1</sup> An artificial reef is a human-made underwater structure, typically built for the purpose of promoting marine life in areas of generally featureless bottom.

***Essential Fish Habitat***

For the larger floating wind turbine platforms proposed for deployment at the Monhegan test site, NMFS in a letter dated February 22, 2011, concurred that the project may affect, but would not likely adversely affect ESA-listed fish, marine mammals, and sea turtles or EFH under the Magnuson-Stevens Fishery Conservation and Management Act. NMFS also concurred that impacts to protected marine mammals are unlikely to occur. In a letter dated August 18, 2011, USFWS concurred that the project effects are likely to be insignificant and discountable and would not likely adversely affect the ESA-listed roseate tern and piping plover (DOE 2011). As described below, the effects of temporarily deploying a single 1/8-scale platform and turbine at the Castine site would have similar or less effects than those identified for testing at the Monhegan site.

Three ESA-listed fish species, Atlantic salmon, shortnose sturgeon, and Atlantic sturgeon, have the potential to occur in the project area. All three species were detected at the Dice Head acoustic detection array during monitoring from 2009 to 2011. Movements through the array were seasonal with Atlantic salmon movements focused in May, Atlantic sturgeon movements throughout the year but focused in May and October, and shortnose sturgeon movements occurring from May to July (Zydlowski 2012). These three species use the project area as a migration corridor. This part of Penobscot Bay is very expansive and quite deep, and the project will not obstruct these species as they swim into and out of the Penobscot River and estuary. Because of the small size of this research project relative to the surrounding marine habitat, the short nature of the deployment, the limited time these migratory would be in the project site, and the overall lack of project effects to fish, the presence of the temporary project would result in a discountable and insignificant effect to these three species, and the project is not likely to adversely affect them.

There are a number of federally managed fish species with EFH in waters off of Castine. Habitat types that represent EFH include all portions of the water column or substrate types, such as soft bottom, hard bottom, and various mixtures of hard and soft (NOAA 2012). The footprint of the anchors may slightly decrease available bottom foraging habitat and areas considered to be EFH. However, the maximum area covered by the anchors (combined area of 64 feet<sup>2</sup>) and the 2½-inch subsea cable conduit and associated strip weights would be very small and the type of habitat to be disturbed is very prevalent along the Maine coast. Placement of anchors and the subsea cable in areas of soft bottom substrate would likely result in a temporary and localized increase in turbidity during deployment and removal; with up to four anchors to be deployed, this effect would be short term and negligible. As discussed above, mobile species such as fish, would likely avoid the immediate deployment area during project installation activities. Project deployment activities for the marine components of the project are expected to total five days (two days to deploy the four anchors, one day to deploy the floating turbine platform, and two days to deploy the subsea cable). Project removal activities would take a similar amount of time. Therefore, any shift in habitat use by marine species during installation or removal activities would be temporary. Because the project is small scale and temporary, effects on EFH (e.g., waters and substrate necessary for fish to spawn, breed, feed, etc.) are expected to be negligible.

The University of Maine also conducted a dive survey of the area and concluded that there were no eel grass or macroalgal dominated habitat that might constitute nursery habitat for juvenile estuary dependent fishes.

### 1.9.2 **Changes to Marine Community Composition**

The anchors, mooring cables, and below-water portions of the turbine platforms could provide habitat for biofouling organisms and structure-oriented fish, which may in turn result in an artificial reef effect. Fishes are also known to aggregate around floating objects (Nelson 2003a), which for that reason are often called Fish Aggregation Devices (FADs). Marine species, including fishes, invertebrates, and marine mammals may avoid the immediate area due to noise produced by the turbines, platform, and anchoring system. The presence of the project components in the water column and floating above the water may therefore result in altered use by marine life in the area and a resulting change in the marine community composition. These potential effects, described further below, are primarily direct effects, though species that may be attracted to the biofouling community, once established, and not necessarily the structures themselves, represent indirect effects of the proposed project.

Mobile species such as pelagic fishes, birds, or marine mammals would likely avoid the deployment area during project installation. Project deployment and removal are expected to total one day per anchor and one day per turbine platform. Therefore, any shift in habitat use of marine species during installation or removal would be temporary.

### 1.9.3 **Artificial Reef**

Common biofouling organisms include algae and sessile invertebrate species, both those having a hard calcium carbonate exterior such as barnacles, mussels, and bryozoans, and soft-bodied organisms such as sponges, tunicates, and hydroids. Biofouling organisms occur at all ocean depths, and therefore are expected to colonize the anchors, mooring cables and portions of the floating platforms below the waterline. The UMaine Physical Oceanography Group, part of the School of Marine Sciences, maintains the Gulf of Maine Array oceanographic buoys within NERACOOS. UMaine researchers have observed that, in general, the spring bloom is a very active period of marine growth that usually starts in March or April of each year, and growth slows by September and October. Biological growth can be variable and is dependent on depth, light, temperature and nutrients. Buoys deployed in the fall and recovered in late winter/early spring typically don't have much growth. Conversely, buoys deployed in the spring and recovered in the fall can have extensive fouling (Figure 1-2); UMaine researchers have reported approximately 15 cm of biofouling growth (species unspecified) for structures deployed through the spring.



**Figure 1-2** *Representative biofouling on Gulf of Maine Oceanographic Buoys. Buoy E01 summer fouling shown on left and Buoy E01 winter fouling shown on right*

Areas of shelter, structure and cover are typically sought by fish for protection from predators (Johnson and Stickney 1989). Artificial structures such as buoys or docks can serve as good sources of cover and refuge—particularly hard substrate having a vertical orientation (USACE 2004). Artificial structures in marine areas where there is comparably little structure associated with the seabed can be particularly attractive to structure-oriented species. Subsequent colonization by marine life that otherwise would not occur in a particular area, in turn, attracts other predatory fish (Ogden 2005).

Many fish species have specific substrate and habitat requirements. In Maine, monkfish and many flatfish species such as American plaice and winter, witch, and windowpane flounder prefer sediment habitats. Other species such as longhorn sculpin, Acadian redfish and Atlantic cod recruit to and often are associated with rocky habitats (Collette and Klein-MacPhee 2002). In some cases, organisms that recruit to hard substrates such as deep-water corals create preferred nursery habitats for recruiting groundfishes (Auster 2005). Thus it is possible that the anchors and chains placed into soft-sediment habitats would diversify substrate heterogeneity that could increase the recruitment potential for some species of groundfish (UMaine, unpublished).

Sampling conducted before and after installation of the Vindeby Offshore Wind Farm along the Danish coast found that fish abundance increased (Robert Gordon University 2002). The Minerals Management Service's (MMS) Rigs to Reefs program reported 20 to 50 times more fish near artificial reefs with biofouling than in the surrounding waters (MMS 2007). Previous environmental assessments for wave energy projects have identified marine biofouling as a potential direct benefit to marine biological resources (U.S. Department of



the Navy 2003). A relatively small reef effect is expected; the two platforms and moorings represent a relatively small surface area below the waterline in comparison to that of floating offshore oil platforms or large European, nearshore wind farms.

#### 1.9.4 FAD Effect

Related to artificial reef effects, fishes are also known to aggregate around floating objects (Nelson 2003a), which is often called a FAD (Fish Aggregation Device) effect. FAD definitions vary, but generally FADs (or structures acting as FADs) are assumed to be floating at or near the surface of the water. The degree of proximity can vary by species, ranging from less than 1 m from the structure for many juvenile fishes, to 1 km or more for large pelagic fishes like tunas. These pelagic communities are usually more ephemeral than reef-associated communities (P. Nelson, Pacific States Marine Fisheries Commission, personal communication with P. Browne, HDR, July 19, 2010). Nelson (2003a) found that fish assemblages associated with FADs supporting a well-developed biofouling community were larger and more diverse than those around FADs devoid of a biofouling community.

Many cases are documented of aggregations associated with drift algae (Mitchell and Hunter 1970; Kokita and Omori 1998; Safran and Omori 1990), oil platforms (Love et al. 2000), ice floes (Crawford and Jorgenson 1993) and other more durable debris (Parin and Fedoryako 1999) in higher latitudes. Although anchored FAD design consists fundamentally of an anchor, line, and buoy (McPhaden 1993; Friedlander et al. 1994; Hassan 1994; Higashi 1994; Nelson 2003a), even very simple designs have been shown to attract fish in great numbers (Hunter and Mitchell 1968; Beets 1989; Hair et al. 1994; Hall et al. 1999a; Hall et al. 1999b; Nelson 1999). Development of an artificial reef or attraction of structure-oriented fish may in turn also attract other predators including marine mammals and birds.

## 2.0 Monitoring Equipment, Methods, and Data Analysis

The following describes monitoring equipment and methods, data analysis and distribution (to MDEP and agencies as required by LD 1465 Public Law 270), and criteria for addressing adverse effects.

### 2.1 LISTED BENTHIC AND DEMERSAL MARINE SPECIES

No benthic or demersal marine species are federally or state listed, with the exception of diadromous fishes, addressed in Section 2.3.

### 2.2 LISTED MARINE MAMMALS

Five large whale species are federally or state listed: humpback, right, fin, sei, and sperm whale. See Commercial Fishing and Marine Resources Report for details on listed Marine Mammals. Monitoring plans are presented in Section 2.8.

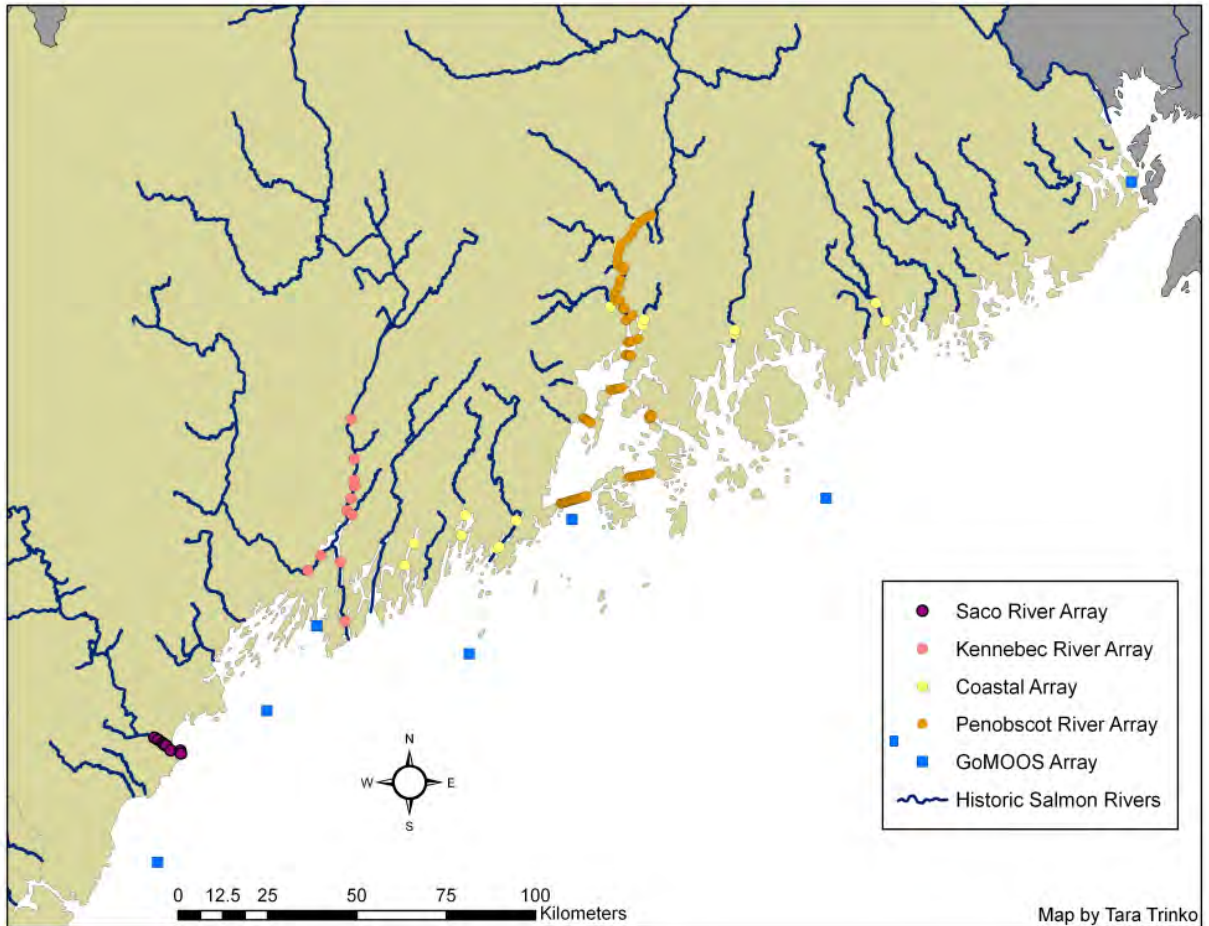
### 2.3 LISTED MARINE FISH

#### 2.3.1 Monitoring Equipment and Methods

The monitoring plan for the federally or state listed fish species is to deploy acoustic receivers to document presence of tagged fish within the project area, to analyze tag data from the receivers, and to report results. The monitoring relative to federally or state listed fish species has been designed by and will be implemented under the direction of Dr. Gayle Zydlewski, University of Maine.

Hundreds to upwards of 1,000 Atlantic salmon are outfitted with acoustic tags in the Gulf of Maine and Bay of Fundy every year. In 2010, at least 50 shortnose sturgeon captured in the Gulf of Maine were tagged acoustically (pers. communication, G. Zydlewski, UMaine). In addition, hundreds of Atlantic sturgeon and striped bass are being tagged every year along the Atlantic coast. Over 60 researchers in the Atlantic Coast Telemetry Network are tagging over 20 different migratory fish species coast-wide (Dewayne Fox, Delaware State University pers. comm. with G. Zydlewski, September, 2010). Dr. Zydlewski is an active participant in the Atlantic Coast Telemetry Network and is regular contact with researchers involved with tagging federally and state listed fish species along the entire U.S. and Canadian Atlantic seaboard.

Monitoring for listed fish species will be accomplished via many acoustic receivers deployed near Castine, ME (see Section 1.3 for more detail). These receivers can document presence of Atlantic salmon, shortnose sturgeon, Atlantic sturgeon, striped bass, and any other species fitted with a 69 kHz acoustic tag. In addition, tagged listed fish species identified at other regional receivers, shown in Figure 2-1, will be documented and reported to the extent that regional receivers are maintained through independent programs, primarily the NERACOOS buoy program. (The GoMOOS array is now known as the Gulf of Maine array within NERACOOS.)



**Figure 2-1** *Map of the coast of Maine depicting locations of acoustic receivers.*

***Pre-Deployment Monitoring-***

Section 1.3 describes the Pre-Deployment Monitoring data.

***Demonstration Project Monitoring***

The same types of units used for pre-deployment monitoring will be continuously deployed at the test site and regularly monitored by NOAA NMFS and Dr. Zydlewski.

**2.3.2 Data Analysis and Distribution**

Data from the receivers will be recovered from the acoustic receivers during regular maintenance and buoy turn-around, approximately every six months. Data from the receiver deployed on the demonstration platform will be recovered at least twice each month during the period of platform testing.

After each download, tag codes will be identified to species and confirmed with the scientist who tagged the animal. Dr. Gayle Zydlewski is in regular contact with researchers conducting tagging studies and will ensure accurate reporting of tagged species. Species detections will then be analyzed in accordance with known animal distribution patterns to determine whether the test site is within a migratory corridor or encompasses the daily/seasonal region of distribution for the species. Results will be reported to MDEP and agencies as required by LD 1465 Public Law 270 (see Section 3.0). Tag data from receivers will be analyzed to allow identification of any tagged species within approximately 1 km of the receivers.

As quickly as possible after each data recovery, Dr. Zydlewski will prepare a report identifying presence of state and federally listed species, and other tagged species. Given the requirement to confirm tagged species details with the researcher responsible for the tagging, there may be a slight delay after data recovery in providing information to the agency. All reasonable effort will be made to provide a report of the presence or absence of listed fish species within 10 days of each data recovery.

Species that have been tagged in the region and may be identified in the area include: shortnose sturgeon (tagged in the Penobscot River, and more recently in the Saco and Kennebec Rivers in 2010); Atlantic sturgeon (tagged in the St. John, Penobscot, Kennebec, Saco, Merrimack, Hudson, Delaware); Atlantic salmon (tagged in the Bay of Fundy and Penobscot River); striped bass (tagged in the Kennebec and Penobscot Rivers); American eel (tagged at Wells Reserve); and Atlantic cod (tagged in NH).

**2.3.3 Criteria for Assessing Adverse Impacts**

No mechanisms for adverse impacts on diadromous species have been identified. Nevertheless, endangered species will be monitored directly via acoustic receivers to assess whether the test site is unexpectedly trafficked by migrations of tagged individuals of these diadromous species at a rate that could involve adverse risks.

**2.4 LISTED SEA TURTLES**

Given the expectation that sea turtles do not frequent the test site area, dedicated monitoring is not planned for these species. However, marine mammal observers have been trained in visual observation techniques for sea turtles and will report any sightings of them to A. Pershing, who will include this information along with reports on marine mammal sighting data. We do not anticipate adverse impacts because sea turtles are rare in the Gulf of Maine and because no mechanism for potential harm has been identified.

**2.5 LISTED AVIAN SPECIES**

Listed avian species will be monitored through the same methods employed for avian species generally, see Section 2.6.

**2.6 AVIAN SPECIES**

**2.6.1 Monitoring Equipment and Methods**

The highest priority for monitoring impacts of the test turbines on bird species is assigned to migrating songbirds, foraging seabirds, and potentially bald eagles or other specific species. This priority is based on current understanding of bird species in the test site area, as described in the Commercial Fishing and Marine Resources Report, and assessment of potential impacts, as described above. Monitoring activities at the test sites will determine direct effects on birds and bats during winter/spring. The monitoring relative to avian species has been designed by and will be implemented under the direction of Laura Kennedy of Lubird Environmental Inc. (who also performed the pre-deployment monitoring which keeps consistency across observers).

Primary components of monitoring for birds will include:

- Opportunistic and dedicated visual surveys (including boat based surveys and web camera deployment) for birds in the test site area.
- Ongoing interpretation of bird and bat data collected at and near Castine within the context of data collected through other research projects throughout the region.

Monitoring does not allow for identifying if birds or bats are struck by the turbine rotor (adverse impact to birds and bats); rather, the radar, which doesn't quite reach the site, has allowed for determination that a majority of birds and bats fly well above the rotor height. Continued monitoring during the testing of the turbine and platform will determine if there is seasonal or interannual variation.

**Pre-deployment monitoring**

During UMaine’s 17 boat-based surveys from March through June of 2012, a total of 1,009 birds, representing 33 identified species, were recorded, with the three most abundant species being common eider (*Somateria mollissima*, 38%), herring gull (*Larus argentatus*, 20%), and common loon (*Gavia immer*, 9%) (Kennedy 2012). A list of the most common bird species observed is presented in Table 2-1.

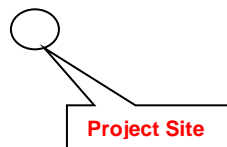
There are two ESA-listed birds that have the potential to occur in the project area, roseate tern (*Sterna dougallii*) and piping plover (*Charadrius melodus*). One unidentified tern (*Sterna sp.*) and no piping plovers were observed during the UMaine field surveys (Kennedy 2012).

The USFWS created a list of species requiring special conservation action and awareness: the Birds of Conservation Concern 2008 (USFWS 2008). Species of Conservation Concern counted in the project area included 18 red-throated loons (*Gavia stellata*), three bald eagles (*Haliaeetus leucocephalus*), one peregrine falcon (*Falco peregrines*), two razorbills (*Alca torda*), and one unidentified tern. The most recent bald eagle nest sites close to the test site are approximately 2.5 miles south of the test site on Brooks Island (Figure 2-2).

**Table 2-1 Most common bird species observed offshore of Castine.**

Common name	Scientific name	Total number	No. of observations
Common eider	<i>Somateria mollissima</i>	379	28
Herring gull	<i>Larus argentatus</i>	206	154
Common loon	<i>Gavia immer</i>	95	75
Black guillemot	<i>Cepphus grylle</i>	57	48
Red-breasted merganser	<i>Mergus serrator</i>	41	29
Double-crested cormorant	<i>Phalacrocorax auritus</i>	39	26
Unidentified duck species		35	12
Red-throated loon*	<i>Gavia stellata</i>	18	13
American crow	<i>Corvus brachyrhynchos</i>	17	11
Turkey vulture	<i>Cathartes aura</i>	16	3
Red-breasted merganser	<i>Mergus serrator</i>	13	3

\*25 species other species were also observed in lesser numbers. Asterisk indicates Bird of Conservation Concern-species. Source: Kennedy 2012.





Map courtesy of C.Todd (Maine Department of Inland Fisheries and Wildlife). Source: Kennedy 2012.

**Figure 2-2** *Locations of most recent bald eagle nest sites in project vicinity (210B and 210D).*

***Demonstration Project Monitoring***

During the period of turbine demonstration platform deployment (March – June 2013), boat based visual surveys will be performed on site weekly and a web camera will be deployed on the unit to observe if there are any strikes. (Mammal and turtle observations will also be made on those cruises.) Visual observation methods will replicate the pre-deployment monitoring.

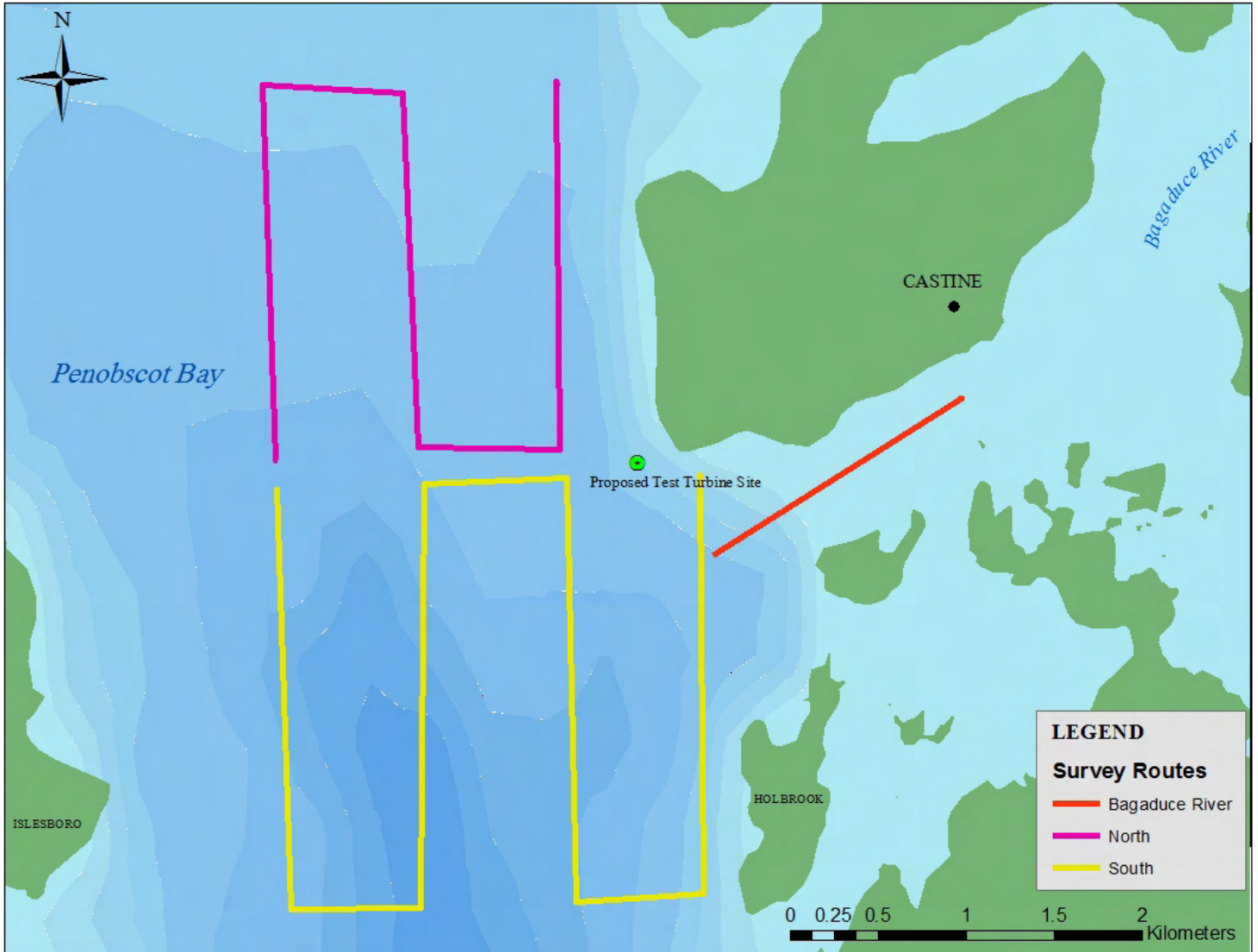
Visual boat-based observations were conducted at the Castine Harbor Dice Head Test Site from March through the end of June, 2013, as seen in Maps 1 and 2. The survey vessels and captains were provided by Maine Maritime Academy, also located in Castine, ME. Exact location of the comprehensive survey area was chosen to best cover the wildlife use of the Bagaduce River’s outlet and the area near Dice Head, the western and southern edge of Castine’s peninsula. No control or test area was designated, such as in the protocol used for the Monhegan Offshore Wind Turbine test site (Kennedy & Holberton, 2011); however two quadrats were surveyed using a similar experimental design, as seen in Map 5.

The “north” quadrat covers the region to the west of the Castine peninsula, which is near Dice’s Head, and the “south” quadrat is adjacent to and south of the “north” quadrat, but also covering more of the river’s outlet and due west of Nautilus Island and the northern

part of Holbrook Island. A third single transect strip was added, at the start of the second survey, to include a one mile strip up from the river's mouth. This was due to abundant bird activity and their use of the Bagaduce River's "Significant Wildlife Habitat," as noted under Focus Areas of Statewide Ecological Significance (BwH, 2012). Originally, at the start of the project, the exact location of the Castine Harbor Dice Head Test Site was found in the north central area of the southern quadrat. By the end of the surveys, it was revealed the location had been moved to an area within an existing cable way (as seen in Map 2) and closer to Dice Head, but at the very north east tip of the southern quadrat, as seen in Map 5.

To prevent confusion, the distinction of "Castine Harbor Dice Head Test Site" refers to the entire surveyed area, and the smaller individual quadrats that lie within this larger area will be hereafter called the "North" or "N," "South" or "S," and "Bagaduce River" or "BR" sites, or quadrats. The complete Castine Harbor Dice Head Test Site covers 3.67mi<sup>2</sup> (9.4 km<sup>2</sup>) with the boat traveling a linear track totaling 9.9mi (15.9km) that includes both quadrats and the river portion. All surveys were assessed equally while using the corresponding total survey areas of the South, North, and Bagaduce River quadrats for the analysis of the species composition, location, and behaviors observed within the Castine Test Site.





Map 5. Location of the survey quadrats used in the Castine Harbor Dice Head Test Site with proposed floating turbine location.

The North quadrat measured 1.5mi by one mile (3.9km<sup>2</sup>) and the South quadrat measured 1.5mi x 1.5mi (5.8km<sup>2</sup>). Surveys were performed with the vessel running at an average speed of 8.4 knots (15.5 k/h) in a N-S direction or from the mouth of the Bagaduce River and heading upstream. Each day's survey began at the starting waypoint in the South quadrat's north east corner. All birds, mammals, and other wildlife were documented when observed out to a distance of 500 m on both sides of the boat. After arriving at the next waypoint, 1.5mi (2.4km) from the starting point, surveying would stop and the boat would turn 90° along an E-W line and motor for a half mile (0.8km) to the next waypoint. Once positioned on the starting point of the second transect strip, the vessel would turn again 90° and surveying would resume, heading in the N-S direction. This pattern was repeated to create four survey strips within the South quadrat (always performed first), followed by a short gap of 0.2 miles and then performing three survey strips, as previously described, to finish the

North quadrat. Immediately following the North quadrat, surveying stopped until the vessel reached the starting point for the Bagaduce River's transect. As previously mentioned, the Bagaduce River strip measured roughly one mile (1.6km) in length and is included in all but the very first survey.

Surveys were conducted aboard Maine Maritime Academy's research vessels, the R/V *Friendship*, a 47-ft converted fishing boat, and the *Spicus*, a 34-ft lobster hull/pleasure boat, both driven by various skilled captains. Observations were conducted from either the bow or stern, depending on sea conditions and safety concerns for that particular day, using binoculars and unaided vision. Height from which observations were made averaged 1.5 m above sea level. All data were recorded into an RCA digital voice recorder, synchronized with time on a Garmin GPS unit that simultaneously logged the boat's tracks and waypoints at the beginning and end of each transect line.

Codes used to document species behaviors and other observation and weather conditions followed Gould & Forsell(1989) and Tasker et al. (1984). Examples of common bird behaviors include but are not limited to sitting on the water, flying in direct and consistent headings, flying with changing directions, and feeding at the water's surface. Brief descriptions are provided below. Other information included flight height, recorded in single meters when under a height of five meters or otherwise compartmentalized into five-meter bins (10, 15, 20, 25, etc.) up to 50 m. Observations were documented as "> 50 m" for all those above 50 m. The number of birds, species, gender and age (if known), and flight direction (see details below) were recorded. The data were transcribed into Excel and mapped with ArcMap software.

In the following sections, maps and tables are provided that summarize species and behaviors observed during the 17 pelagic surveys at the Castine Test Site during the 2012 spring survey period. Table 2-2 explains some of the numerical behavior codes used in the preceding tables that summarize bird and marine mammals observed in each survey.

**Table 2-2** *Example of most common codes used to document behaviors observed during transects (Gould & Forsell, 1989).*

Bird Behavior
01 = Sitting on water
20 = Flying in direct and consistent heading
32 = Flying, following ship
35 = Flying, milling or circling (foraging)
48 = Flying, meandering
61 = Feeding at or near surface while flying (dipping or pattering)
66 = Feeding at or near surface, not diving or flying (surface seizing)
70 = Feeding below surface (pursuit diving)
Mammal & Fish Behavior
00 = Undetermined
02 = Feeding
06 = Porpoising
08 = Sleeping

Some of the most common behaviors documented have lengthy definitions; therefore a shortened descriptive behavior term is used in the following sections. These include the following codes: **#20**, described as “flying in a direct and consistent heading” but hereafter shortened to “direct flight”; **#35**, described as “flying, milling or circling” which typically involves flight associated with foraging behavior and is erratic in height and location, hereafter called “milling”; **#48**, described as “flying, meandering” which involves indirect flight that changes direction but not necessarily height, hereafter called “meandering”; **#61**, described as “feeding at or near the surface while flying (dipping or pattering)” which typically describes scavenging or the act of picking food from the water’s surface, hereafter called “dipping”; **#66**, described as “feeding at or near surface, not diving or flying (surface seizing)” which differs from dipping in that the bird is sitting in the water while foraging, hereafter called “surface seizing”; and **#70**, described as “feeding below surface (pursuit diving)” which involves the bird diving under the water from a seated position on the water, hereafter called “pursuit diving.”

At the top of each survey days’ section (below), a list of the species and numbers observed for that day, separated into North, South, and Bagaduce River Quadrats, is presented. Four-letter species “alpha” codes may be used in the following tables to simplify table content. Flight directions, given in cardinal direction such as NE, SW, WNW, represent the direction in which the bird was flying at the time of observation.

### 2.6.2 Criteria for Assessing Adverse Impacts

Avian and bat (see Section 2.7) mortality through direct collision with the turbines is one of the primary wildlife impacts expected with wind projects. Due to the limited duration of deployment (4.5 mo during 1 or 2 yr) and the offshore nature of the test site, traditional bird

casualty monitoring protocols as used for onshore wind farms is not feasible. A program for opportunistically monitoring bird casualties will be implemented in association with pelagic, benthic, and geologic survey work in the test site and surrounding area, and mortalities will be evaluated during the regular (weekly to biweekly) bird surveys planned for the test deployment. This, in combination with the extensive monitoring and analysis outlined in Sections 2.6.1 and 2.6.2, should provide an adequate basis for assessing adverse impacts to avian populations.

## 2.7 BAT SPECIES

### 2.7.1 Monitoring Equipment, Methods, and Analysis

The proposed monitoring for bat species consists of pre-deployment and deployment monitoring using bat echolocation detectors. Methods and analysis for bat acoustic investigations are detailed below.

Bats use high frequency echolocation to maneuver through the landscape during migration or in search of food and water. Although the echolocation sounds produced by bats are above the frequency range of human hearing, electronic equipment can be used to record these high frequency sounds. Acoustic sampling of bat activity has become a standard pre-construction survey for proposed wind-energy development (Kunz *et al.* 2007). This type of sampling allows for long-term passive monitoring in a variety of habitat types and locations. Although acoustic surveys are associated with several major assumptions (Hayes 2000) and results cannot be used to determine the number of bats inhabiting an area, acoustic surveys can provide insight into patterns in bat activity, species composition, and use of an area.

One acoustic detector system consisting of a primary and backup detector was deployed on the platform of the Dice Head Lighthouse tower at a height of approximately 14 meters (m) above ground level. The lighthouse is located approximately 85 m from the high tide mark and is surrounded by habitat consisting of a mix of deciduous and coniferous trees, developed residential lawns, and light residential development. The lighthouse is attached to an occupied residence with a maintained lawn.

Anabat SDI detectors (Tittle Electronics Pty Ltd.) were used for data collection based upon their widespread use for this type of survey, their ability to be deployed for long periods of time, and their ability to detect a broad frequency range, allowing detection of all species of bats that could occur in Maine. Anabat detectors are frequency division detectors, dividing the frequency of echolocation sounds made by bats by a factor of 16 and then recording these sounds onto removable compact flash cards for subsequent analysis. Detectors were programmed to begin monitoring at 18:00 hours each night and end monitoring at 08:00 hours each morning. The audio sensitivity setting of each Anabat system was set between 6 and 7 (on a scale of 1 to 10) to maximize sensitivity while limiting ambient background noise and interference. The sensitivity of individual detectors was then tested using an ultrasonic Bat Chirp (Reno, NV) to determine that the detectors would be able to detect bats up to a distance of at least 10 m (33').

The acoustic system consisted of two SD1 detectors, powered by a single 12-volt battery charged by two 10-watt solar panels. The SD1 detectors were deployed in separate waterproof housings with a 90 degree PVC elbow used to direct bat calls into the microphone while protecting the units from the weather (Photo 2-2). This standardized system has been used at the majority of long-term acoustic bat surveys conducted by Stantec. Temperature and relative humidity were measured at the survey site using a datalogger set to record at 15-minute intervals (Onset, HOBO model Pro V2 U23-001).

#### ***Pre-deployment monitoring***

The DeepCWind Consortium, led by the University of Maine, is pursuing installation of a scaled down, floating wind turbine in the waters of the Gulf of Maine near Castine, Maine. As part of the permitting process for this test turbine, Stantec Consulting Services, Inc. (Stantec) conducted an acoustic bat survey between mid-May through early July, 2012. Surveys were conducted from the tower of the Dice Head Lighthouse in Castine, the nearest feasible monitoring location to the site at which the test turbine is to be deployed. Survey methods followed those used by similar assessments of bat activity for on-shore commercial wind projects and in offshore bat monitoring conducted by Stantec in the Gulf of Maine since 2009.

An acoustic detector was deployed on the tower of the Dice Head Lighthouse on May 22, 2012, and operated on a nightly basis through the night of July 10, 2012. A total of 797 bat call sequences were recorded during this period. Between 0 and 107 call sequences were recorded per night, with an overall activity level of 15.9 call sequences per detector-night. Bats were detected during 42 out of 50 surveyed nights (84 percent). Of the 797 recorded call sequences, 422 (53 percent) were identified to species or guild and the remaining 375 call fragments were too short to be identified but were classified as either high frequency or low frequency “unknown”. The BBSH guild, including the big brown bat (*Eptesicus fuscus*) and silver-haired bat (*Lasionycteris noctivagans*) was the most frequently identified guild, followed by bats in the *Myotis* genus. Eastern red bats (*Lasiurus borealis*) and hoary bats (*Lasiurus cinereus*) were also documented at the site.

#### ***Demonstration Project Monitoring***

It is anticipated that paired bat echolocation detectors would be deployed again during deployment.

### **2.7.2 Criteria for Assessing Adverse Impacts**

Avian and bat (see Section 2.7) mortality through direct collision with the turbines is one of the primary wildlife impacts expected with wind projects. Due to the limited duration of deployment (4.5 mo) and marine nature of the test site, traditional bird and bat casualty monitoring protocols as used for onshore wind farms are not feasible. A program for opportunistically monitoring bat casualties will be implemented and mortalities will be evaluated during the regular (weekly) bird surveys planned for the test deployment in addition to a web camera deployment.

## 2.8 MARINE MAMMALS

### 2.8.1 Monitoring Equipment and Methods

As discussed in Section 2.6, marine mammals will be monitored using the visual survey techniques used on avian species. Based on the lack of frequent whale sightings in the region, we do not expect whales to be common in the test site area. We have thus elected to devote our limited resources to characterizing the habitat use of marine mammals using visual observation.

Visual surveys will be conducted pre-deployment and during demonstration platform testing. Surveys will be conducted by DeepCwind researchers (Principal Investigators, graduate students, and technicians) who have received in-depth training in at-sea identification.

The protocols for DeepCwind visual observations of marine mammals have been developed in line with other regional Platforms of Opportunity Survey protocols. These protocols are being implemented to allow us to standardize the data and to be able to say where marine mammals did not occur as well as where they did occur. Our protocol is meant to provide information that can be added to the Right Whale Consortium Database, the largest database of cetacean sightings in the Gulf of Maine. The DeepCwind marine mammal sightings guide and data sheet for visual observations were developed based on existing regional protocols. A full-day training in marine mammal visual observation techniques was provided on June 29, 2010 for all active DeepCwind marine researchers likely to participate in at-sea research.

#### *Pre-deployment Monitoring*

During the 2012 boat-based visual surveys, UMaine observers counted 66 harbor seal (*Phoca vitulina*), one grey seal (*Halichoerus grypus*), and 34 harbor porpoise (*Phocoena phocoena*). Individuals of these three marine mammal species combined, were found at a density of 0.38 animals/km<sup>2</sup> (Kennedy 2012). North Atlantic right, humpback, minke (*B. acutorostrata*), and fin whales do occur in the outer Penobscot Bay and Gulf of Maine (UMaine 2008), but large whale species are not be expected to occur in the project area because it is located in the upper portion of Penobscot Bay.

#### *Demonstration Project Monitoring*

A program of opportunistic visual observations for marine mammals and sea turtles will be implemented in association with pelagic, benthic, and geologic survey work in the test site and surrounding area. Dedicated visual surveys will also be conducted during the daytime pelagic cruises. Survey methods are outlined in Section 2.6 All sightings and data from the visual surveys will be provided to the Right Whale Consortium database.

Limited data analysis is anticipated and will generally consist of weekly to biweekly marine mammal observations to be performed during the deployment period and formally recorded and included in quarterly reporting to Agencies. Other marine mammal and/or turtle

observations will be accomplished opportunistically. In addition, agencies will be provided a monthly observation summary over the course of the test deployment period.

**2.8.2 Criteria for Assessing Adverse Impacts**

No mechanisms for adverse impacts on marine mammals have been identified. Nevertheless, using opportunistic and dedicated visual surveys, we will monitor the site to see whether marine mammal patterns change due to the deployment and, if so, whether there is any evidence that the effects are adverse. Other Marine Resources – Benthic, Demersal, and Pelagic Species

**2.8.3 Monitoring of impacts on benthic, demersal, and pelagic resources will be undertaken using before-after, control-impact (BACI) study design. Pre-deployment surveys for benthic and demersal species were undertaken in April 2012. This monitoring consisted of diver suveys that indicated that the site was dominated by muddy sediments. Marine worms and sand dollars were als observed. A remotely operated vehicle survey will be used to observe the site during deployment and afterwards. Marine Resources: Video Assessment of Benthic Invertebrates and Demersal Species Based on Drop Camera Surveys -- Monitoring Equipment and Methods**

The area of the proposed University of Maine Deepwater Offshore Wind Test Site and local reference control areas of the same character will be surveyed by remotely-operated vehicle (ROV). The primary monitoring objective is to assess changes in species composition and density in the areas in close proximity to the anchors.

Sampling for benthic and demersal species has been planned to occur primarily during the spring 2013. Surveys are conducted within the proposed deployment site and two adjacent control areas having similar depth and substrate characteristics but at least 1 km from the deployment area. Replicate, randomized belt transect segments are conducted with well established methods

Survey cameras with the laser scale are used to quantify population densities, species composition and body sizes of all benthic and demersal megafauna (primarily decapods and groundfishes). Survey cameras require parallel lasers set at 100 mm to provide a length scale for the organisms being surveyed. For benthic megafaunal communities, video surveys will use a regular switchback sampling design covering the deployment footprint and a control area.

***Pre-deployment Monitoring***

In 2012, UMaine researchers used side scanning sonar with seismic reflection data to evaluate the surficial geology of the project area and found that the test site is dominated mostly by fine grain sediments, specifically, a heavy clay type mud with few to no rocks, ecological growth, or other features. The only exceptions were two sites located closer to the shore and in shallower water than the proposed location of the floating platform, which had a more pebble/small rock and gravel-type bottom. A groundtruthing diver survey corroborated the findings.

***Demonstration Project Monitoring***

Benthic surveys employing the same methods as pre-deployment surveys are planned during the period when the turbine is deployed.



### 3.0 Distribution of Data to MDEP

Pursuant to the requirements of LD 1465 Public Law 270, quarterly monitoring reports will be distributed to MDEP, which will briefly summarize monitoring efforts and describe any adverse impacts that have been identified, along with any proposed measures necessary to reduce or eliminate such impacts. In addition, agencies will be provided a monthly observation summary over the course of the test deployment period, including any relevant observations of benthic invertebrates, fish, marine mammals, flying vertebrates, and environmental conditions.

Also, as required by LD 1465 Public Law 270, an annual report will be filed with the MDEP which will include monitoring results and any recommendations for modifying the generating facilities or other project elements, or commencing the approved project removal plan, if necessary to minimize adverse effects on natural resources. A draft report will be issued to Department of Marine Resources (MDMR), the Department of Inland Fisheries and Wildlife (MDIFW), the Department of Conservation (MDOC), the United States Fish and Wildlife Service (USFWS) and the National Marine Fisheries Service (NMFS) for a 30-day review period prior to submitting the final report to MDEP. The final report will include any comments from those agencies and identify how they were addressed in the final report, as appropriate.

#### 4.0 Detailed Implementation Schedule

Collection of pre-deployment data and analysis of background information relevant to fish and wildlife monitoring began in 2012. Collection of monitoring data will continue during the turbine deployment period. An environmental monitoring report shall be issued to agencies in July (see Section 3 for reporting and distribution guidelines).

## 5.0 Detailed Monitoring Schedule

The monitoring schedule has been designed to encompass the seasonal window during which the project is proposed to take place (March – June 2013). In addition, the monitoring priorities, study design, methods, and analysis are designed as appropriate for the oceanographic conditions and seasonal variability in species use of the test site. The specific requirements constraining timing for each study is described in Sections 2 and 7. There will be slight variation in the dates for monitoring studies in the environmental impact monitoring, if weather or other uncontrollable logistical issues arise. However, the researchers undertaking these studies are experienced working in the region and familiar with the conditions they may encounter. Project plans and study designs are robust to all foreseeable issues.

## 6.0 Identifying & Implementing Remedial Measures

Based on the results of the monitoring described in Section 2, UMaine, through its subcontractors, will identify and implement remedial measures if adverse changes to fish or other wildlife behavior are identified. Specific criteria for identifying any adverse impacts are included in Section 2. Should adverse impacts occur, UMaine will consider and evaluate, in consultation with relevant resource agencies and the MDEP, appropriate remedial measures, such as temporary shut-down of turbine operation or other modified operations to decrease direct impacts on species or noise produced.

We will also be sensitive to unanticipated adverse impacts detected during this study or strongly implicated by observations made elsewhere. Communication with the appropriate regulatory agency is emphasized throughout the Adaptive Management Plan.

Based on experience with terrestrial wind farms, collision and near-collision of aerial vertebrates with blades during low visibility and foul weather is the most likely adverse impact. Hence during the pre-deployment radar studies we will focus on developing correlative relationships between flight altitudes and behaviors and weather and visibility from the met-ocean buoy.

## 7.0 Ambient Noise, EMF, Noise from Project

Existing noise levels in the project area are expected to be typical of a near-shore/estuarine setting having relatively high boat traffic because of its proximity to Castine Harbor. In the marine/estuarine environment, a variety of natural and anthropogenic sources create ambient noise, both intermittent and continuous. Sources of ambient noise include waves, wind, bubbles and spray, marine life, seismic events, commercial and recreational vessel traffic, and thermal noise from random agitation of water molecules (Bradley and Stern 2008; Richardson et al. 1995). Ambient noise pressure spectral densities can range from about 35 to 80 decibels [referenced to one micropascal squared per hertz (re 1  $\mu\text{Pa}^2/\text{Hz}$ )] for usual marine traffic (10 to 1,000 hertz) as shown in Table 7-1, and 20 to 80 decibels (re 1  $\mu\text{Pa}^2/\text{Hz}$ ) for breaking waves and associated spray and bubbles (100 to 25,000 hertz; Richardson et al. 1995).

**Table 7-1 Underwater sound pressure levels for various types of vessels.**

Vessel Length and Description	Frequency (Hz)	Source Level (dB re 1 $\mu\text{Pa}$ at 1 meter)
Outboard drive – 23 feet (2 engines, 80 horsepower each)	630	156
Twin Diesel – 111 feet	630	159
Small Supply Ships – 180 to 278 feet	1,000	125-135 (at 50 meters)
Freighter – 443 feet	41	172

Source: Richardson et al. 1995

During the boat-based visual survey at the Castine project site, observation of boat traffic occurred during 17 surveys from April to June 2012. A total of 13 boats were observed while surveys were performed. Six of the boats were various types of sailing vessels, four were assorted private motorized boats, and the remaining three were fishing vessels for lobster or fish.

The Port of Searsport is located northwest, across Penobscot Bay from Castine, and the Penobscot River ports of Bucksport and Bangor are located north of Castine, up the Penobscot River. NOAA navigation charts identify two Recommended Vessel Routes that run the length of Penobscot Bay, and the edge of the nearest route is located approximately 3,000 feet west of the proposed deployment location.

In the open ocean setting, the primary noise sources tend to be commercial shipping and wind and wave action on the sea surface (Richardson et al. 1995). Noise sources are expected to be similar at the project site, though upper Penobscot Bay, being more sheltered than the open ocean, would not have as much wind and wave action as there is in the open ocean. Anthropogenic sources of noise in the project area would include fishing and recreational boats originating from Castine Harbor and elsewhere, as well as periodic traffic of larger ships and barges associated with the ports to the north of Castine.

The installation, operation, and removal of the floating wind turbine and subsea cable would result in a temporary increase in underwater noise created from service vessels and equipment, similar to vessels commonly used throughout the coast, and may temporarily cause marine life to avoid the project area and along the route that the platform would be transported during deployment and removal. Operation of the wind turbine would produce noise and may sometimes be audible to people on shore, close to the project (i.e. Dyce Head).

The predominant source of noise during project installation, maintenance, and removal would be the service vessels' propellers (MMS 2007). As discussed in Section 2.2.7, the pilot prototype unit and its anchorages would be installed using Maine Maritime Academy's unlimited tugboat *The Pentagoet*, or a similar vessel. *The Pentagoet* is 70 feet long and is powered by a 1,200 HP design engine. It is expected that the peak underwater sound intensity, generated by a tug fully underway, will be no greater than 130 to 160 decibels (re 1  $\mu$ Pa) over a frequency range of 20 hertz to 10 kilohertz (Richardson et al. 1995). The tug or smaller research vessels should be fully underway only when traveling to and from the test site. It is expected that most of the time during project activities the sound intensity would be much lower.

During project installation, maintenance, and removal, it is expected that the above-water sounds from the support vessels and equipment would not be transmitted into the water at a higher level than natural environmental noise from wind and wave action. The Federal Regulatory Commission, in its environmental assessment for the Makah Bay Wave Energy Project in Washington, concluded that above-water sounds from support vessels and equipment would be largely damped by ambient ocean noise on all but the calmest of days (FERC 2007).

UMaine expects installation of the marine components of the project would take a total of about five days (two days to deploy the four anchors, one day to deploy the turbine platform, and two days to install the subsea cable). Project removal activities would take a similar amount of time. Underwater noise associated with the installation, maintenance, and removal activities might cause some fish, marine mammals, birds, and other marine life to avoid the project area; however, any effects would be short term, with behavior returning to normal after the service vessels leave the site.

Noise created during project operation would be from the mechanical motion of the internal turbine components as well as the aerodynamic interaction of the rotor blades with the surrounding air. The Renewegy 20 kW turbine creates noise levels of about 50 dB at 120 feet (Renewegy 2012). For comparison, a 2-person conversation is about 47 dB (Bradley and Stearn 2008).

Sound levels underwater resulting from turbine noise transferred through the sea surface are expected to be substantially lower than the sound source levels, due to the reflective nature of the sea surface (Jones et al. 2010). Acoustic emissions underwater, due to vibrations of the turbine and platform structure, are expected to be low frequency and low amplitude, and are strongly dependent on turbine and platform configuration and dynamic loads (Jones et al. 2010). Because of the low level of noise created by a Renewegy 20 kW turbine, the temporary nature of the deployment, and because only a small amount of sound can transfer through the sea surface from above, underwater noise levels resulting from turbine operation are expected to be very low and to not negatively affect marine mammals or fish.

In conclusion, noise associated with project installation, maintenance, and removal activities would be infrequent, short term, and negligible, with activities returning to normal after the service vessels leave the site. During operation, the turbine would produce negligible noise, and is not expected to affect people on shore. Because of the small scale and temporary nature of the turbine, and because only a small amount of sound can transfer through the sea surface from above, underwater noise resulting from turbine operation is not expected to negatively affect marine life.

## 8.0 Provisions for Filing an Annual Report

University of Maine will file an annual report with MDEP that describes the monitoring results and any recommendations for modifying the generating facilities or other project elements, or commencing the approved project removal plan, if necessary to minimize adverse effects on natural resources. Thirty days prior to submission of the report to the department, the University of Maine will provide a draft of the report to the Department of Marine Resources, the Department of Inland Fisheries and Wildlife, the Department of Conservation, the United States Fish and Wildlife Service, the National Marine Fisheries Service and the United States Army Corps of Engineers and shall include in the annual report any comments from those agencies and the responses to them.



## 9.0 References

- Aker, P., A.M. Jones and A.E. Copping. 2010. Offshore wind turbines: Estimated noise from offshore wind turbine, Monhegan Island, Maine. Environmental effects of offshore wind energy development. Pacific Northwest National Laboratories, Sequim, WA. Report PNNL 20015.
- Aker, P., and A.E. Copping. 2011. Addendum to Aker et al. (2010) for the cases of two turbines located 4.1 – 4.7 km from Monhegan Island.
- Arnett, E.B., M MP Huso, MRShirmacher, JPHayes (2011), “Altering turbine speed reduces bat mortality at wind-energy facilities” *Frontiers in Ecology and Environment*. 9(4), 209-214.
- Baerwald, E., G. D'Amours, B. Klug, R. Barclay. 2008. Barotrauma is a significant cause of bat fatalities at wind turbines. *Current Biology* 18: 695-696.
- Boué, M. 2007. Long range sound propagation over the sea with application to wind turbine noise. Final report for the Swedish Energy Agency project 21597-3 (TRANS). TRITA-AVE 2007: ISSN 1651-7660.  
[http://cvi.se/uploads/pdf/Kunskapsdatabas%20miljo/Ljud%20och%20Skuggor/Ljud/Forskningsresultat/V-201\\_TRANS\\_webb.pdf](http://cvi.se/uploads/pdf/Kunskapsdatabas%20miljo/Ljud%20och%20Skuggor/Ljud/Forskningsresultat/V-201_TRANS_webb.pdf)
- Bolin, K., M. Boué and I. Karasalo. 2009. Long range sound propagation over a sea surface. *Journal of the Acoustical Society of America* 126:2191-2197
- Bradley, D. L. and R. Stern. 2008. Underwater Sound and the Marine Mammal Acoustic Environment, A Guide to Fundamental Principles. Prepared for the U.S. Marine Mammal Commission. July 2008.
- Carter, T. D. 1950. On the migration of the red bat (*Lasiurus borealis borealis*). *Journal of Mammalogy* 31: 349-350.
- Cryan, P.M. and R.M.R. Barclay. 2009. Causes of Bat Fatalities at Wind Turbines: Hypotheses and Predictions. *J. Mammalogy* 90:1330-1340.
- Christensen, T. K. and J. P. Houninsen. 2005. Investigations of migratory birds during operation of Horns Rev offshore wind farm. Annual status report. 2004. National Environmental Research Institute. Cited in MMS 2009.

- Federal Energy Regulatory Commission. 2007. Environmental Assessment for Hydropower License. Makah Bay Offshore Wave Energy Pilot Project. FERC Project No. 12751-000. May 21, 2007.
- Gehring, J., P. Kerlinger, A.M. Manville II, 2009. Communication towers, lights, and birds: successful methods of reducing the frequency of avian collisions. *Ecological Applications*, 19(2), 2009, pp. 505–514.
- Griffin, O.M. 1985. Vortex-induced vibrations of marine cables and structures. Naval Research Laboratory Memorandum Report 5600. 25 pp.  
<http://www.boemre.gov/tarprojects/074/74AF.pdf>
- Halcrow Group. 2006. Wave Hub Environmental Statement. South West of England Regional Development Agency.
- Horn, J. E. Arnett, T. Kunz. 2008. Behavioral Responses of Bats to Operating Wind Turbines. *J. Wildlife Management* 72:123-132.
- Huppopp, O., J. Dierschke, K. M. Exo, E. Fredrich, and R. Hill. 2006. Bird migration studies and potential collisions risk with offshore wind turbines. *Ibis*. 148:90-109. Cited in MMS 2009.
- Imber, M. 1975. Behavior of petrels in relation to the moon and artificial lights. *Notornis* Vol. 22, pp. 216-222.
- Johnson, J. B., Gates, J. E., 2008. Bats of Assateague Island National Seashore, Maryland. *American Midlands Naturalist* 160: 160–170.
- Jones, M., P. Ramuhalli, and M. Watkins. 2010. Characterization of acoustic noise propagation from offshore wind turbines – white paper. Pacific Northwest National Laboratory, Richland, WA. Unpublished.
- Kang, M., M. Furusawa, and K. Miyashita. 2002. Effective and accurate use of difference in mean volume backscattering strength to identify fish and plankton. *ICES J. Mar. Sci.* 59: 794-804.
- Kerlinger, P., J.L. Gehring, W.P. Erickson, R. Curry, A. Jain, J. Guarnaccia. Night Migrant Fatalities and Obstruction Lighting at Wind Turbines in North America. *The Wilson Journal of Ornithology* 122(4):744–754, 2010.
- Ketten, D. R. 2000. Cetacean ears. Pages 43-108 In: Au, W.W.L., Popper, A.N. & Fay, R.R., (editors). *Hearing in Whales and Dolphins*. Springer Verlag New York.
- Kunz, T. H., E. B. Arnett, B. A. Cooper, W. I. P. Erickson, R. P. Larkin, T. Mabee, M. L. Morrison, J. D. Strickland, and J. M. Szewczak. 2007a. Assessing impacts of wind energy development on nocturnally active birds and bats. *Journal of Wildlife Management* 71: 2449–2486.
- Kunz, T. H. E.B. Arnett, W.P. Erickson, A. R. Hoar, and G. D. Johnson. 2007b. Ecological impacts of wind energy development on bats: questions, research needs, and hypotheses. *Front Ecol Environment* 5:315-324.

- Kunz, T. H. 2010. Presentation: **Wind Turbine Interactions with Birds, Bats, and their Habitats: A Summary of Research Results and Priority Questions**. Spring 2010 [www.nationalwind.org](http://www.nationalwind.org)
- Ljungblad, D. K., B. Würsig, S. L. Swartz, and J. M. Keene. 1988. Observations on the behavioral responses of bowhead whales (*Balaena mysticetus*) to active geophysical vessels in the Alaskan Beaufort Sea. *Arctic* 41:183-194. Cited in NMFS 2008.
- Malme, C. I., B. Würsig, J. E. Bird, and P. Tyack. 1988. Observations of feeding gray whale responses to controlled industrial noise exposure. Pages 55-73 in W. M. Sackinger, M. O. Jeffries, J. L. Imm, and S. D. Treacy, editors. *Port and ocean engineering under arctic conditions*, Volume III. University of Alaska, Fairbanks, Alaska. Cited in NMFS 2008.
- Malme, C. I., P. R. Miles, C. W. Clark, P. Tyack, and J. E. Bird. 1984. Investigations on the potential effects of underwater noise from petroleum industry activities on migrating whale behavior/Phase II: January 1984 migration. BBN Report 5586, Bolt Beranek and Newman, Inc., Cambridge, Massachusetts, for U.S. Minerals Management Service, Anchorage, Alaska, NTIS PB86-218377. Cited in NMFS 2008.
- Malme, C. I., P. R. Miles, C. W. Clark, P. Tyack, and J. E. Bird. 1983. Investigations on the potential effects of underwater noise from petroleum industry activities on migrating whale behavior. BBN Report 5366, Bolt Beranek and Newman, Inc., Cambridge, Massachusetts, for U.S. Minerals Management Service, Anchorage, Alaska, NTIS PB86-174174. Cited in NMFS 2008.
- Minerals Management Service. 2007. Draft Programmatic EIS for alternative energy development and production and alternative use of facilities on the Outer Continental Shelf. U.S. Department of the Interior. March 2007.
- Minerals Management Service. 2009. Cape Wind Energy Project Final Environmental Impact Statement.
- Montevocchi, W. A. 2006. Influences of artificial light on marine birds. In: C. Rich and T. Longcore (Editors) *Ecological Consequences of Artificial Night Lighting*. Island Press, Washington, D.C.
- Norton, A. H., 1930. A red bat at sea. *Journal of Mammalogy* 11: 225-226.
- Pye, H., Watson, W. 2004. Sound detection and production in the American lobster, *Homarus americanus*: Sensitivity range and behavioral implications *J. Acoust. Soc. Am.* Volume 115, Issue 5, pp. 2486-2486.
- Reed, J. R., J. L. Sincock, and J. P. Hailman. 1985. Lighting attraction in endangered procellariiform birds: reduction by shielding upward radiation. *Auk* 102:377-383.
- Richardson, W. J., C. R. Greene, Jr., C. I. Malme, and D. H. Thomson. 1995. *Marine Mammals and Noise*. Academic Press, London.
- Simmonds, E.J., and D. MacLennan. 2005. *Fisheries acoustics: theory and practice*. 2nd Edition. Blackwell Science, Oxford.

- Southall, B. L., A. Bowles, W. Ellison, J. Finneran, R. Gentry, C. Greene Jr., D. Kastak, D. Ketten, J. Miller, P. Nachtigall, J. Richardson, J. Thomas, and P. Tyack. 2007. Marine mammal noise exposure criteria: initial scientific recommendations. *Aquatic Mammals*, Vol 33, No 4, 2007.
- Tyack, P. L. and C. W. Clark. 1998. Quick-look: playback of low-frequency sound to gray whales migrating past the central California coast – January 1998. Unpublished report. Cited in NMFS 2008.
- Weir, R. D. 1976. Annotated Bibliography of Bird Kills at man-made Obstacles: A Review of the State of the Art and Solutions. Canadian Wildlife Service, Ottawa
- Zimmerman, G. S., 1998. Inventory and habitat use of bats along the central coast of Maine. Thesis (M.S.) in Zoology-University of Maine, 1998.

# Visual Observations for Birds, Turtles, and Marine Mammals at the University of Maine Test Site near Castine, Maine.



*A report submitted to the University of Maine's Advanced Structures  
and Composites Center*

*October 2012*

*by*

**LAURA KENNEDY, MS**

*Lubird Kennedy Environmental Services*

Bar Harbor, Maine

[lubirdkennedy@yahoo.com](mailto:lubirdkennedy@yahoo.com)

918-549-5625

## TABLE OF CONTENTS

I.	Executive Summary .....	1
II.	Introduction .....	2
III.	Location.....	4
IV.	Methods.....	7
V.	Results .....	11
	A. March 7, 2012 Survey .....	13
	B. March 16, 2012 Survey .....	16
	C. March 20, 2012 Survey .....	19
	D. March 28, 2012 Survey .....	22
	E. April 4, 2012 Survey.....	25
	F. April 12, 2012 Survey.....	28
	G. April 18, 2012 Survey.....	31
	H. April 28, 2012 Survey.....	34
	I. May 4, 2012 Survey .....	37
	J. May 7, 2012 Survey .....	40
	K. May 18, 2012 Survey.....	44
	L. May 22, 2012 Survey.....	47
	M. May 31, 2012 Survey.....	50
	N. June 5, 2012 Survey.....	53
	O. June 15, 2012 Survey.....	56
	P. June 19, 2012 Survey.....	59
	Q. June 29, 2012 Survey.....	62
VI.	Behavior Categories.....	65
	A. Non-bird Species Summary.....	65
	B. Bird Species Behavior Summaries.....	67
	1. Direct Flight Behavior.....	68
	2. Meandering Flight Behavior .....	71
	3. Milling Flight Behavior .....	73
	4. Other Behaviors.....	74
	C. Endangered, Threatened, and Birds of Conservation Concern .....	78
	1. Red-throated loon .....	79
	2. Bald eagle .....	80
	3. Peregrine falcon .....	82
	4. Razorbill.....	82
	5. Tern.....	82
	D. Other Miscellaneous Observations .....	82
	1. Boats & Buoy Observations.....	82
VII.	Summary.....	86
VIII.	Acknowledgements .....	93
IX.	Literature Cited.....	98

### TABLES:

Table 1. Example of most common codes used to document behaviors observed during transects.....	10
Table 2. Surveys by time of day and corresponding weather conditions.....	11

Table 3.	Total numbers of wildlife observed by time of day and month .....	11
Table 4.	Numbers of species observed during the morning survey on March 7 <sup>th</sup> .....	13
Table 5.	Species, behavior code, flight height, and flight direction on March 7 <sup>th</sup> .....	15
Table 6.	Numbers of species observed during the Mar 16 .....	16
Table 7.	Species, behavior code, flight height, and flight direction on Mar 16 .....	18
Table 8.	Numbers of species observed during the Mar 20 .....	19
Table 9.	Species, behavior code, flight height, and flight direction on Mar 20 .....	21
Table 10.	Mar 28 .....	22
Table 11.	Mar 28 .....	24
Table 12.	Apr 4 .....	25
Table 13.	Apr 4 .....	27
Table 14.	Apr 12 .....	28
Table 15.	Apr 12 .....	30
Table 16.	Apr 18 .....	31
Table 17.	Apr 18 .....	33
Table 18.	Apr 28 .....	34
Table 19.	Apr 28 .....	36
Table 20.	May 4 .....	37
Table 21.	May 4 .....	39
Table 22.	May 7 .....	40
Table 23.	May 7 .....	43
Table 24.	May 18 .....	44
Table 25.	May 18 .....	46
Table 26.	May 22 .....	47
Table 27.	May 22 .....	49
Table 28.	May 31 .....	50
Table 29.	May 31 .....	52
Table 30.	June 5 .....	53
Table 31.	June 5 .....	55
Table 32.	June 15 .....	56
Table 33.	June 15 .....	58
Table 34.	June 19 .....	59
Table 35.	June 19 .....	61
Table 36.	June 29 .....	62
Table 37.	June 29 .....	64
Table 38.	Marine mammal observations by date and location .....	65
Table 39.	Numbers and locations of species sitting on the water .....	75
Table 40.	Numbers and locations of species displaying foraging activities .....	75
Table 41.	Species per square kilometer surveyed .....	79
Table 42.	Buoy observations by date and transect location .....	84
Table 43.	Species per square kilometer surveyed by quadrat .....	86
Table 44.	Species and numbers flying in the rotor sweep-zone .....	89

## MAPS:

Map 1.	Castine and Penobscot Bay in Maine, with survey region map inset .....	2
Map 2.	Location of the test site and the proposed floating platform location off Dice Head .....	3
Map 3.	The Bagaduce River Watershed (BwH map) .....	5
Map 4.	Significant Wildlife and Essential Habitats (MTPI Presentation map) .....	6
Map 5.	Location of the survey quadrats used in the Castine Test Site with proposed test turbine location .....	8
Map 6.	March 7 observations .....	14

Map 7. March 16 observations .....	17
Map 8. March 20 observations .....	20
Map 9. March 28 observations .....	23
Map 10. April 4 observations.....	26
Map 11. April 12 observations.....	29
Map 12. April 18 observations.....	32
Map 13. April 28 observations.....	35
Map 14. May 4 observations .....	38
Map 15. May 7 observations .....	42
Map 16. May 18 observations.....	45
Map 17. May 22 observations.....	48
Map 18. May 31 observations.....	51
Map 19. June 5 observations.....	54
Map 20. June 15 observations .....	57
Map 21. June 19 observations .....	60
Map 22. June 29 observations .....	63
Map 23. Marine mammals.....	66
Map 24. Foraging species .....	76
Map 25. Birds of Conservation Concern locations .....	81
Map 26. Buoy locations .....	85
Map 27. Locations of most recent Bald Eagle nest sites (MDIFW) .....	91

## FIGURES:

Figure 1. Numbers of marine mammal observations by date .....	65
Figure 2. Direct flight, by Groups .....	68
Figure 3. Direct flight heights .....	70
Figure 4. Direct flight directions.....	70
Figure 5. Milling flight, by Groups.....	71
Figure 6. Milling species, flight height, and numbers.....	72
Figure 7. Meandering flight, by Groups .....	73
Figure 8. Meandering species, flight height, and numbers .....	74
Figure 9. Numbers of all birds demonstrating foraging behaviors and the associated height above the water.....	77
Figure 10. Behaviors demonstrated by Birds of Conservation Concern .....	78
Figure 11. Observation dates of Birds of Conservation Concern.....	80
Figure 12. Flight heights for all flying birds .....	87
Figure 13. Flight direction and number by behavior code .....	90

## APPENDICES:

Appendix 1: Behavioral codes (Gould & Forsell 1989).....	94
Appendix 2: Species listed by most abundant to least, totals, and most common behaviors.....	95
Appendix 3: Species codes, scientific names, and date sighted.....	96-97
Appendix 4: Species observed by date, time of day, and numbers recorded.....	98



## **Public Use Statement**

This report contains data collected through federal funds provided by the University of Maine's Advanced Structures and Composites Center (Ct-07B-20111024\*2017). While the information provided in this report is meant for public access, permission is required to reproduce figures, tables, and any other product contained within this report without the express permission of the University of Maine's Advanced Structures and Composites Center.

Suggested citation for this report:

Kennedy, L. 2012. "Visual Observations for Birds, Turtles, and Marine Mammals at the University of Maine Test Site near Castine, Maine; Spring 2012. A report submitted to the University of Maine's Advanced Structures and Composites Center. "

## Executive Summary

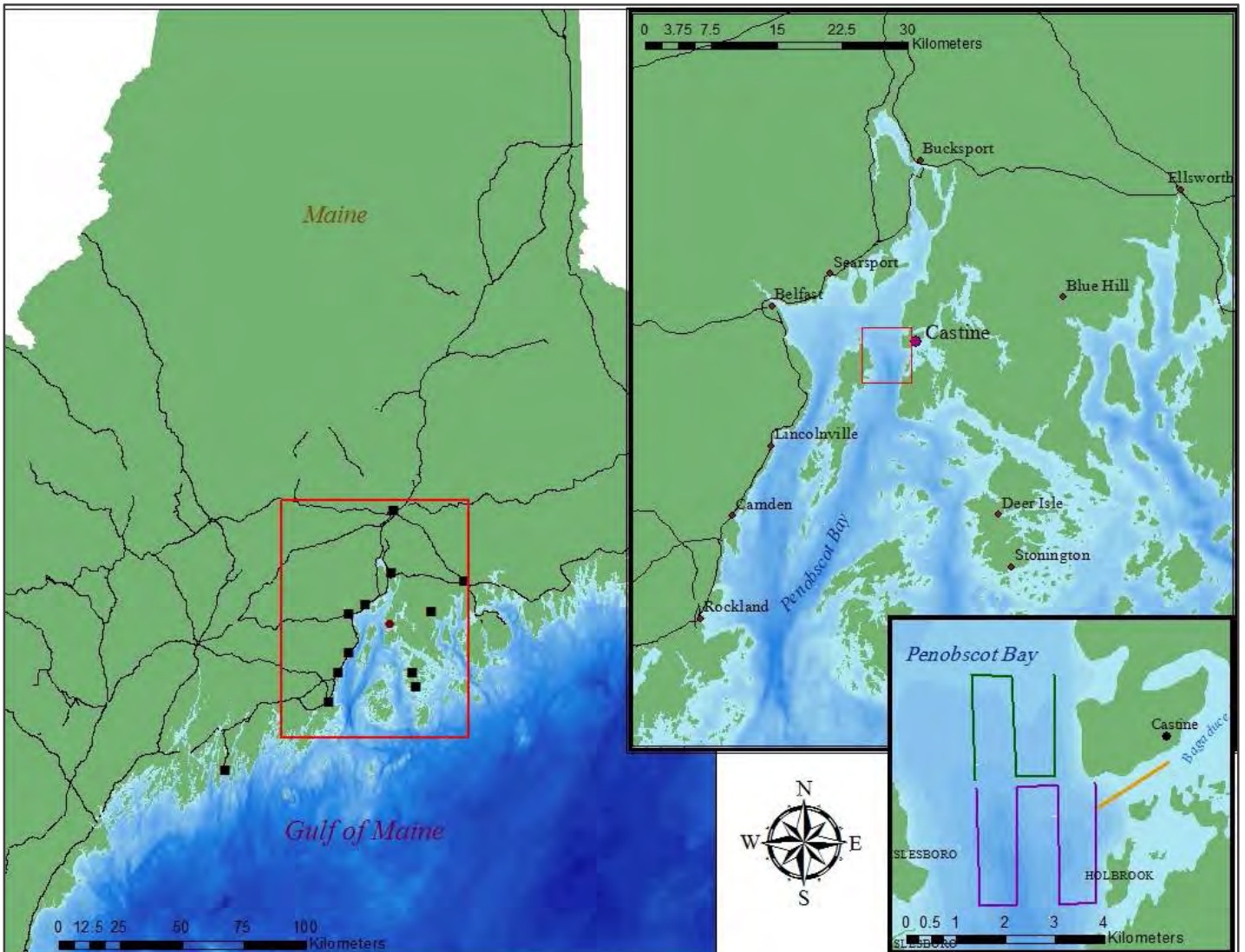
Seventeen boat-based surveys were conducted from March through June of 2012 at the Castine Harbor Dice Head Test Site near Castine, Maine. The primary objectives were to record observations of seabirds and other wildlife at the proposed test site during the pre-deployment stage where the University of Maine's single VoltturnUS 20kW wind turbine on a 1/7<sup>th</sup> commercial scale floating platform will be located. Observations included species, number, behavior, flight height and direction, as well as weather and sea conditions.

A total of 1,009 birds were recorded (3.82 birds/km<sup>2</sup>), with the three most abundant species being Common eider (*Somateria mollissima*, COEI), Herring gull (*Larus argentatus*), and Common loon (*Gavia immer*). Numbers of Harbor seals, Harbor porpoise, and Gray seal totaled 101 marine mammals (0.38/km<sup>2</sup>). Species of Conservation Concern (SCC) included 18 Red-throated loons (*Gavia stellata*), three Bald eagles (*Haliaeetus leucocephalus*), one Peregrine falcon (*Falco peregrines*), two Razorbills (*Alca torda*), and one unidentified tern (*Sterna sp.*).

The most common bird behaviors included sitting on the water (51% were COEI), direct flight (79% in the family Anseriformes), and milling flight (57% were gull species). Of the flying birds, the majority flew under five meters, but 22.4% flew from 10m-20m which is the proposed height of the test turbine's rotor-sweep zone. Although the test turbine is small-scale, gulls may have the greatest potential for impact due to collision. The greatest source of impact, however, may involve disturbance due to avoidance of the structure and human-related activities of maintenance and operation, particularly by seaducks, waterfowl, and loons.

## INTRODUCTION

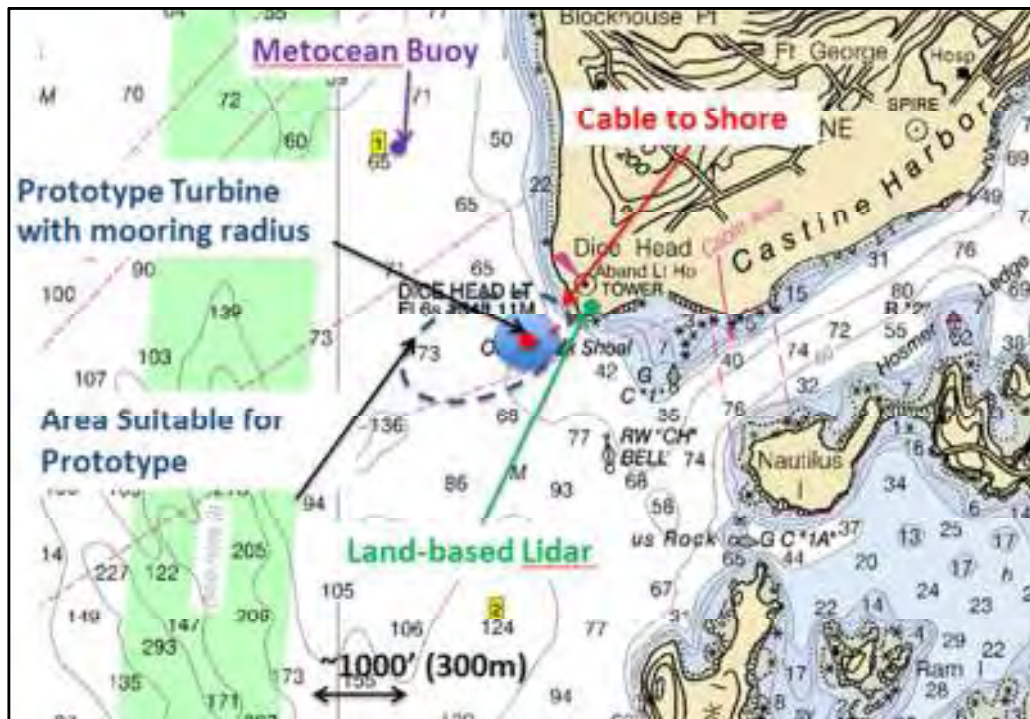
The Gulf of Maine (GOM) is a well-known avian corridor for the millions of songbirds, raptors, shorebirds, wading birds, and waterfowl to pass through during the spring and fall migration (Goodale & Divoll 2009). Over 300 documented species of all major avian taxa frequent the GOM region and more data is currently being accumulated that supports a growing list of known-wintering species. For the purposes of this report, our area of focus lies near Castine, ME midway along Maine's coast at the mouth of the Penobscot River, in Penobscot Bay (Map 1).



Map 1. Castine and Penobscot Bay in Maine, with survey region inside the smaller red box in inset map.

This survey was initiated as a request for data at the Castine Test Site to be used in the environmental assessment for DeepCWind's VoltturnUS 1/7 scale Turbine Platform Test Unit. Specific information about species found near the Dice Head Lighthouse area, flight heights, and behaviors is needed in order to better understand the birds' habitat use of the site (e.g., feeding, resting, and passing through the area). It is also essential to assess potential risks as a result of human activities associated with the siting, construction, operation, and removal of turbine structures. Resource agencies such as the Maine Department of Inland Fisheries and Wildlife and the United States Fish and Wildlife Service consider monitoring bird activity with respect to offshore wind development a high priority (USFWS Wind Turbine Guidelines Advisory Committee, 2012).

The location of the VoltturnUS 1/7th scale Turbine project is found at N44°22'49", W68° 49' 17" in the waters off Dice's Head at Castine, Maine, in an existing cableway (Map 2).



Map 2. Location of Castine Pilot Prototype Site near Castine, Maine. Map courtesy of University of Maine's Advanced Structures & Composites Center.

The primary objectives of this study include 1) determining bird and marine wildlife species compositions and their current activities and habitat use of the Castine Harbor Dice Head Test Site and 2) using this information to assess potential risk or behavior conflicts that may occur due to the presence of the one 20kW wind turbine on a 1/7<sup>th</sup> commercial scale floating platform and its operations and maintenance. These risks will include potential collision with both above and below surface structures such as blades and spar,

and platform anchoring lines. Other behavioral conflicts may arise due to the operational boat traffic and other sources of increased human presence, noise, vibrations, and additional structure presence.

This report includes observations made only during the pre-deployment period that corresponds with the proposed calendar period of installation and operation at the University of Maine's Castine Test Site. DeepCwind's proposal for a single 20m tall, 20 kW test turbine is scheduled for deployment sometime during the period from March through the end of June, 2013. The proposed project, as initially described, is small in scale and temporary. Boat-based survey protocols vary across different studies, with the selection of the final methodology entirely dependent on the objectives of the study. The survey design developed for this project and interpretation of the results are limited to the temporary and short-term activities described in the initial proposal. Additional observations are imperative once the project, including installation and operation, begins, and again if any substantial changes are made to the proposed structures or site location.

## LOCATION

Castine lies on the west side of the Blue Hill peninsula and on the north-west bank of the Bagaduce River, which is a 12-mile (19.3km) stretch of flowing tidal water that converges into Penobscot Bay. The BioDiversity Research Institute ([www.briloon.org](http://www.briloon.org)) has created a Ranking of Bird Use map that categorizes areas from High to Low bird use. The numerous islands that lie at the outer edge of Penobscot Bay, particularly on the tip of the Blue Hill Peninsula, have a concentrated zone of High bird use. Further up the bay, however, near Castine and in the area surveyed in this report, bird use rates as "Low" (BRI, 2012).

Two important areas of this region of the Blue Hill Peninsula and Penobscot Bay are considered "Significant Wildlife Areas": the Bagaduce River watershed and Holbrook Island Sanctuary.

Like the GOM region, the Penobscot Bay region contains important and diverse ecosystems for many species of birds, invertebrates, fish, and shellfish, largely due to the Bagaduce River's ecological significance (Map 3). Because of this abundance of wildlife and habitat, the Bagaduce River Watershed has been designated by the Beginning with Habitat (BwH) organization ([www.beginningwithhabitat.org](http://www.beginningwithhabitat.org)) as a "Focus Area of Statewide Ecological Significance" that includes Significant Wildlife Areas for Inland Wading Bird and Waterfowl Habitat, Tidal Wading bird and waterfowl habitat, and Significant Shorebird Area (BwH, 2012). Map 3 shows the location of the Castine Harbor Dice Head Test Turbine site, which is not inside the Bagaduce River watershed, but is in the vicinity.

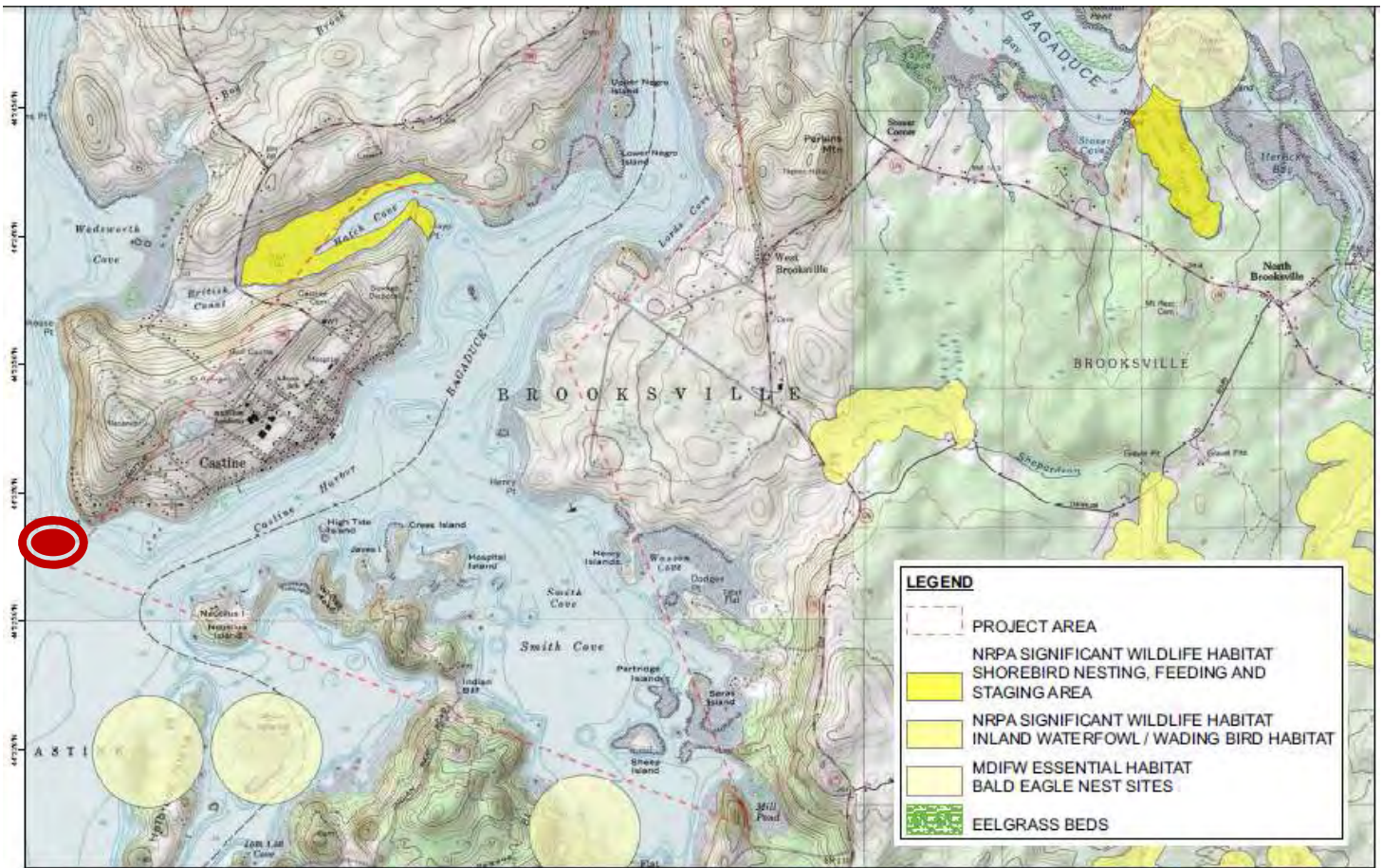


Map 3. The Bagaduce River Watershed. Map courtesy of *Beginning With Habitat* ([www.beginningwithhabitat.org](http://www.beginningwithhabitat.org)). The purple circle represents the Castine Harbor Dice Head Turbine Test site location.

Not only is the area of the Bagaduce River’s 2,700 acres available for waterfowl and wading birds’ feeding, breeding, and migratory stopover, but it is also one of a few locations in Maine where American horseshoe crabs (*Limulus polyphemus*) are known to breed (BwH, 2012). The Maine Coast Heritage Trust recently received a large federal matching grant to further wetland habitat conservation and land protection efforts in the Bagaduce River watershed due to its important bird habitat status (Berleant 2012). Due to the shallow open waterways and strong tides that help resist freezing in the winter, migrating and wintering waterfowl take refuge in the protected coves of the river. In a collaborative effort with the University of Maine, the Maine Tidal Power Initiative’s Site Resource Assessment (MTPI, 2012) has located specific coves and marshes that provide “NRPA Significant Wildlife Habitat for Shorebird Nesting, Feeding, and Staging Areas” as well as for “Inland Waterfowl & Wading Bird Habitat” within the Bagaduce River’s pathway. As seen in Map 4, the nearest significant habitats to the proposed Castine Harbor Dice Head Test Turbine location are some eel grass beds located in Wadsworth Cove (green patches), a large shorebird nesting, feeding and staging area in Hatch Cove (yellow area), and two tan circles south of Dice Head that represent Bald eagle (*Haliaeetus leucocephalus*) nest sites.

A federally-protected species by the USFWS, Bald eagles are very common in this area, with nesting sites found throughout Maine and particularly in the Bagaduce River watershed. According to the MDIFW eagle biologist Charlie Todd, up to five different breeding pairs are known to utilize this location for nesting (C. Todd, *pers. comm.*, Sept 20,

2012). More detailed discussion regarding the Bald eagle’s status and nesting locations will be presented below, in the *Endangered, Threatened, and Birds of Conservation Concern* section (section IV-part C).



Map 4. Maine Tidal Power Initiative’s Site Resource Assessment Published Habitat Map of Significant Wildlife and Essential Habitats.

The Bagaduce River watershed is a key wildlife corridor for these species, as well as a provider of healthy and diverse economic resources for humans such as harboring natural nurseries for juvenile fish and shellfish, wildlife viewing, and acting as a natural storm surge buffer (BwH, 2012).

Across the Bagaduce River and due south of Castine on the Cape Rosier peninsula lies the Holbrook Island Sanctuary. The sanctuary encompasses 1,230 acres of forests, fields, marshes, ponds, mudflats, and high-value wetland habitat. The Sanctuary is managed by the State of Maine under the Bureau of Parks and Lands, encouraging visitors to hike the trails and enjoy the abundant mammals and birds that frequent the park. A “Checklist of the Birds” for Holbrook Island Sanctuary is available to help birders identify the timing and abundance of the avian species known to utilize this habitat (Holbrook Island Sanctuary,

2001). Out of the 223 birds listed in this checklist, 31 were observed in this survey; 13 of the observed species are also listed as “known to breed in the sanctuary.”

Although both the Bagaduce River watershed and the Holbrook Island Sanctuary are not directly in the area of the Castine Harbor Dice Head Test Turbine Site, the wildlife that use these habitats may, at some point, find contact with the turbine’s location. Due to the proposed siting of the one 1/7<sup>th</sup> commercial scale floating platform near the mouth of the Bagaduce River, these hundreds of species known to use the Sanctuary and Bagaduce River’s habitats may follow the river on their way to Penobscot Bay and the pass by the proposed test turbine’s location. For this reason, it is essential to keep in mind the ecological habitats within the vicinity of the Castine Harbor Dice Head Test Site and the avian species that are known to use its resources.

## METHODS

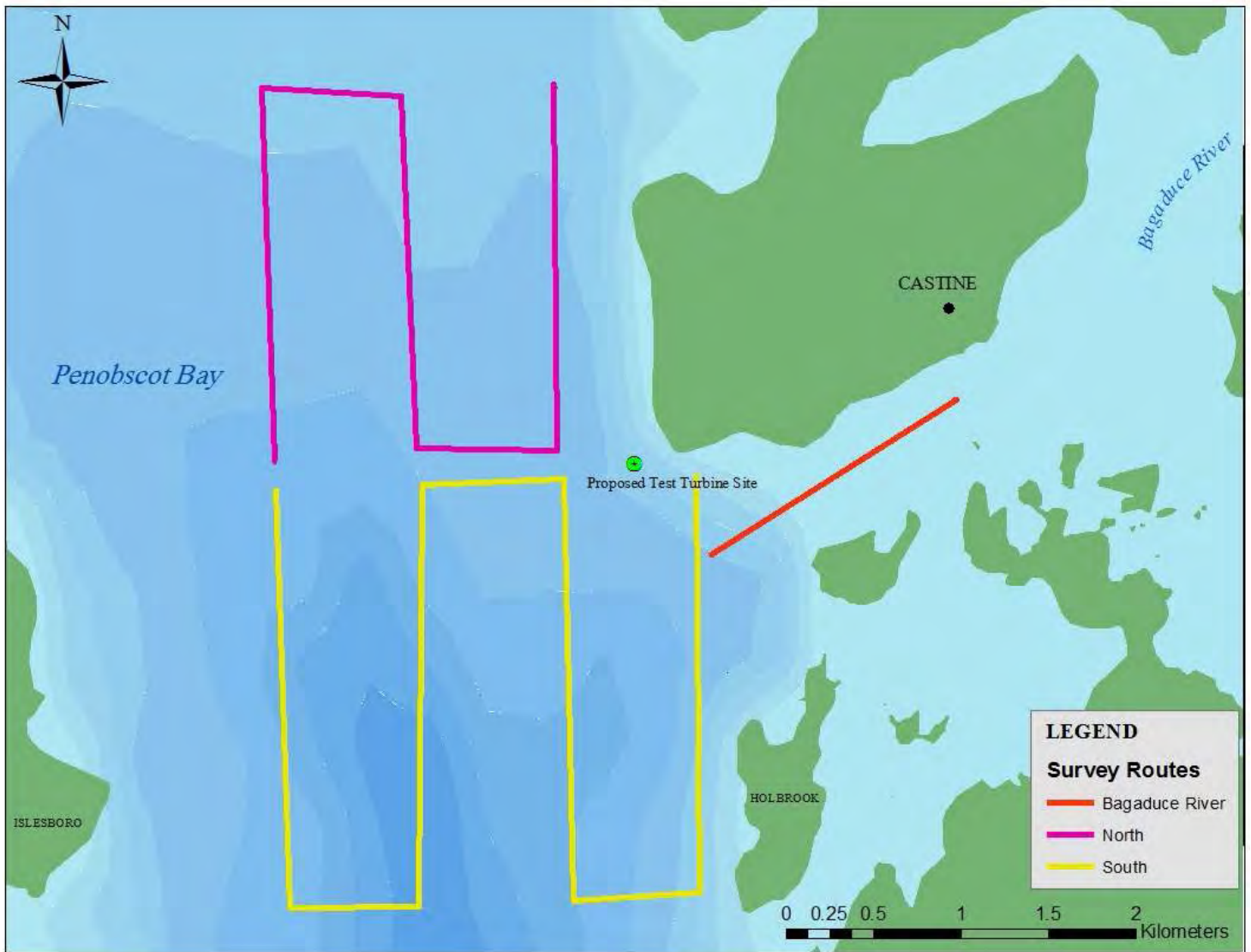
Visual boat-based observations were conducted at the Castine Harbor Dice Head Test Site from March through the end of June, 2013, as seen in Maps 1 and 2. The survey vessels and captains were provided by Maine Maritime Academy, also located in Castine, ME. Exact location of the comprehensive survey area was chosen to best cover the wildlife use of the Bagaduce River’s outlet and the area near Dice Head, the western and southern edge of Castine’s peninsula. No control or test area was designated, such as in the protocol used for the Monhegan Offshore Wind Turbine test site (Kennedy & Holberton, 2011); however two quadrats were surveyed using a similar experimental design, as seen in Map 5.

The “north” quadrat covers the region to the west of the Castine peninsula, which is near Dice’s Head, and the “south” quadrat is adjacent to and south of the “north” quadrat, but also covering more of the river’s outlet and due west of Nautilus Island and the northern part of Holbrook Island. A third single transect strip was added, at the start of the second survey, to include a one mile strip up from the river’s mouth. This was due to abundant bird activity and their use of the Bagaduce River’s “Significant Wildlife Habitat,” as noted under Focus Areas of Statewide Ecological Significance (BwH, 2012). Originally, at the start of the project, the exact location of the Castine Harbor Dice Head Test Site was found in the north central area of the southern quadrat. By the end of the surveys, it was revealed the location had been moved to an area within an existing cable way (as seen in Map 2) and closer to Dice Head, but at the very north east tip of the southern quadrat, as seen in Map 5.

To prevent confusion, the distinction of “Castine Harbor Dice Head Test Site” refers to the entire surveyed area, and the smaller individual quadrats that lie within this larger area will be hereafter called the “North” or “N,” “South” or “S,” and “Bagaduce River” or



“BR” sites, or quadrats. The complete Castine Harbor Dice Head Test Site covers 3.67mi<sup>2</sup> (9.4 km<sup>2</sup>) with the boat traveling a linear track totaling 9.9mi (15.9km) that includes both quadrats and the river portion. All surveys were assessed equally while using the corresponding total survey areas of the South, North, and Bagaduce River quadrats for the analysis of the species composition, location, and behaviors observed within the Castine Test Site.



Map 5. Location of the survey quadrats used in the Castine Harbor Dice Head Test Site with proposed floating turbine location.

The North quadrat measured 1.5mi by one mile (3.9km<sup>2</sup>) and the South quadrat measured 1.5mi x 1.5mi (5.8km<sup>2</sup>). Surveys were performed with the vessel running at an average speed of 8.4 knots (15.5 k/h) in a N-S direction or from the mouth of the Bagaduce

River and heading upstream. Each day's survey began at the starting waypoint in the South quadrat's north east corner. All birds, mammals, and other wildlife were documented when observed out to a distance of 500 m on both sides of the boat. After arriving at the next waypoint, 1.5mi (2.4km) from the starting point, surveying would stop and the boat would turn 90° along an E-W line and motor for a half mile (0.8km) to the next waypoint. Once positioned on the starting point of the second transect strip, the vessel would turn again 90° and surveying would resume, heading in the N-S direction. This pattern was repeated to create four survey strips within the South quadrat (always performed first), followed by a short gap of 0.2 miles and then performing three survey strips, as previously described, to finish the North quadrat. Immediately following the North quadrat, surveying stopped until the vessel reached the starting point for the Bagaduce River's transect. As previously mentioned, the Bagaduce River strip measured roughly one mile (1.6km) in length and is included in all but the very first survey.

Surveys were conducted aboard Maine Maritime Academy's research vessels, the R/V *Friendship*, a 47-ft converted fishing boat, and the *Spicus*, a 34-ft lobster hull/pleasure boat, both driven by various skilled captains. Observations were conducted from either the bow or stern, depending on sea conditions and safety concerns for that particular day, using binoculars and unaided vision. Height from which observations were made averaged 1.5 m above sea level. All data were recorded into an RCA digital voice recorder, synchronized with time on a Garmin GPS unit that simultaneously logged the boat's tracks and waypoints at the beginning and end of each transect line.

Codes used to document species behaviors and other observation and weather conditions followed Gould & Forsell(1989) and Tasker et al. (1984). Examples of common bird behaviors include but are not limited to sitting on the water, flying in direct and consistent headings, flying with changing directions, and feeding at the water's surface. See Appendix 1 for a complete list of behaviors. Brief descriptions are provided below. Other information included flight height, recorded in single meters when under a height of five meters or otherwise compartmentalized into five-meter bins (10, 15, 20, 25, etc.) up to 50 m. Observations were documented as "> 50 m" for all those above 50 m. The number of birds, species, gender and age (if known), and flight direction (see details below) were recorded. The data were transcribed into Excel and mapped with ArcMap software.

In the following sections, maps and tables are provided that summarize species and behaviors observed during the 17 pelagic surveys at the Castine Test Site during the 2012 spring survey period. Table 1 explains some of the numerical behavior codes used in the proceeding tables that summarize bird and marine mammals observed in each survey.

Table 1. Example of most common codes used to document behaviors observed during transects (Gould & Forsell, 1989).

<b>Bird Behavior</b>
01 = Sitting on water
20 = Flying in direct and consistent heading
32 = Flying, following ship
35 = Flying, milling or circling (foraging)
48 = Flying, meandering
61 = Feeding at or near surface while flying (dipping or pattering)
66 = Feeding at or near surface, not diving or flying (surface seizing)
70 = Feeding below surface (pursuit diving)
<b>Mammal &amp; Fish Behavior</b>
00 = Undetermined
02 = Feeding
06 = Porpoising
08 = Sleeping

Some of the most common behaviors documented have lengthy definitions; therefore a shortened descriptive behavior term is used in the following sections. These include the following codes: **#20**, described as “flying in a direct and consistent heading” but hereafter shortened to “direct flight”; **#35**, described as “flying, milling or circling” which typically involves flight associated with foraging behavior and is erratic in height and location, hereafter called “milling”; **#48**, described as “flying, meandering” which involves indirect flight that changes direction but not necessarily height, hereafter called “meandering”; **#61**, described as “feeding at or near the surface while flying (dipping or pattering)” which typically describes scavenging or the act of picking food from the water’s surface, hereafter called “dipping”; **#66**, described as “feeding at or near surface, not diving or flying (surface seizing)” which differs from dipping in that the bird is sitting in the water while foraging, hereafter called “surface seizing”; and **#70**, described as “feeding below surface (pursuit diving)” which involves the bird diving under the water from a seated position on the water, hereafter called “pursuit diving.”

At the top of each survey days’ section (below), a list of the species and numbers observed for that day, separated into North, South, and Bagaduce River Quadrats, is presented. Four-letter species “alpha” codes may be used in the following tables to simplify table content (see Appendix 3 for species codes and common and scientific names). Flight directions, given in cardinal direction such as NE, SW, WNW, represent the direction in which the bird was flying at the time of observation.

## RESULTS

Seventeen survey days, at a consistent rate of one survey per week, were conducted from March through the end of June, 2012. The total area covered on each survey day in the South quadrat measured 8.24km<sup>2</sup>, 6.3km<sup>2</sup> in the North quadrat, and 1.6km<sup>2</sup> in the Bagaduce River's transect. Table 2 provides the breakdown of the surveys by time of day, sea, and weather conditions.

Table 2. Surveys by time of day and corresponding weather conditions.

MONTH	TIME OF DAY		SURVEY CONDITIONS			
	AM	PM	sea ht (ft)	wind dir	wind (kt)	sky
<b>March</b>						
7	X		2-4	S	16	Clear/Partly Cloudy
16		X	0.5-2	SE	7	Rain
20	X		0.5-2	SE	7	Clear
28		X	0.5-2	ESE	10	Overcast/Snow
<b>April</b>						
4	X		0.5-2	N to NW	7	Clear
12	X		0.5-2	N	12	Clear/Partly Cloudy
18		X	0.5-2	WNW to NNW	6	Clear
28	X		2-4	NW to W	16	Clear/Partly Cloudy
<b>May</b>						
4	X		0 - 0.2	S	5	Rain
7		X	0.1	N	5	Clear
18	X		0.1	SW to S	5	Clear
22		X	0.1 - 2	SW to S	5 to 8	Partly Cloudy
31	X		Flat	S	3	Partly Cloudy
<b>June</b>						
5	X		1 - 4	N	8 to 12	Partly Cloudy
15		X	0.3 - 2	N	8	Clear
19		X	2 - 6	S	5	Clear
29	X		Flat - 1.5	SE	3 to 7	Partly Cloudy

Ten of the surveys were conducted in the morning and seven in the afternoon in order to gain a more comprehensive temporal picture of wildlife activity within the Castine Test Site (Table 3).

Table 3. Total numbers of birds and marine mammals observed by time of day and month.

TOTAL WILDLIFE DAY PERIOD	MONTH				Grand Total
	MAR	APR	MAY	JUN	
AM (10 surveys)	180	266	189	108	743
PM (7 surveys)	117	106	129	28	380
<b>Grand Total</b>	<b>297</b>	<b>372</b>	<b>318</b>	<b>136</b>	<b>1123</b>

The majority of the days provided favorable weather, with 14 surveys conducted under clear or partly cloudy skies, two on rainy days, and one day with snow. Winds on average were light, with 12 surveys averaging winds around six knots (~11kph) and the remaining five surveys had winds from 10 to 16 knots (18.5 to 30kph). Ten of the survey days had winds coming from a southerly direction (such as ESE, SE, SW, or S) and the seven remaining surveys averaged a northerly wind (NW, NNW, WNW, NNE, or N).

In addition to the 33 bird species identified, which included 1,009 individual birds counted, the presence of one Gray seal, Harbor seals, and Harbor porpoise were also noted during these surveys (Appendix 3 & Appendix 4). The following sections will discuss each survey's results, grouped by location, starting with birds, and ending with other wildlife. Tables will present species numbers, locations, and each species' behaviors (also summarized in Appendix 2). The maps will summarize species location in reference to the anticipated floating platform's location.

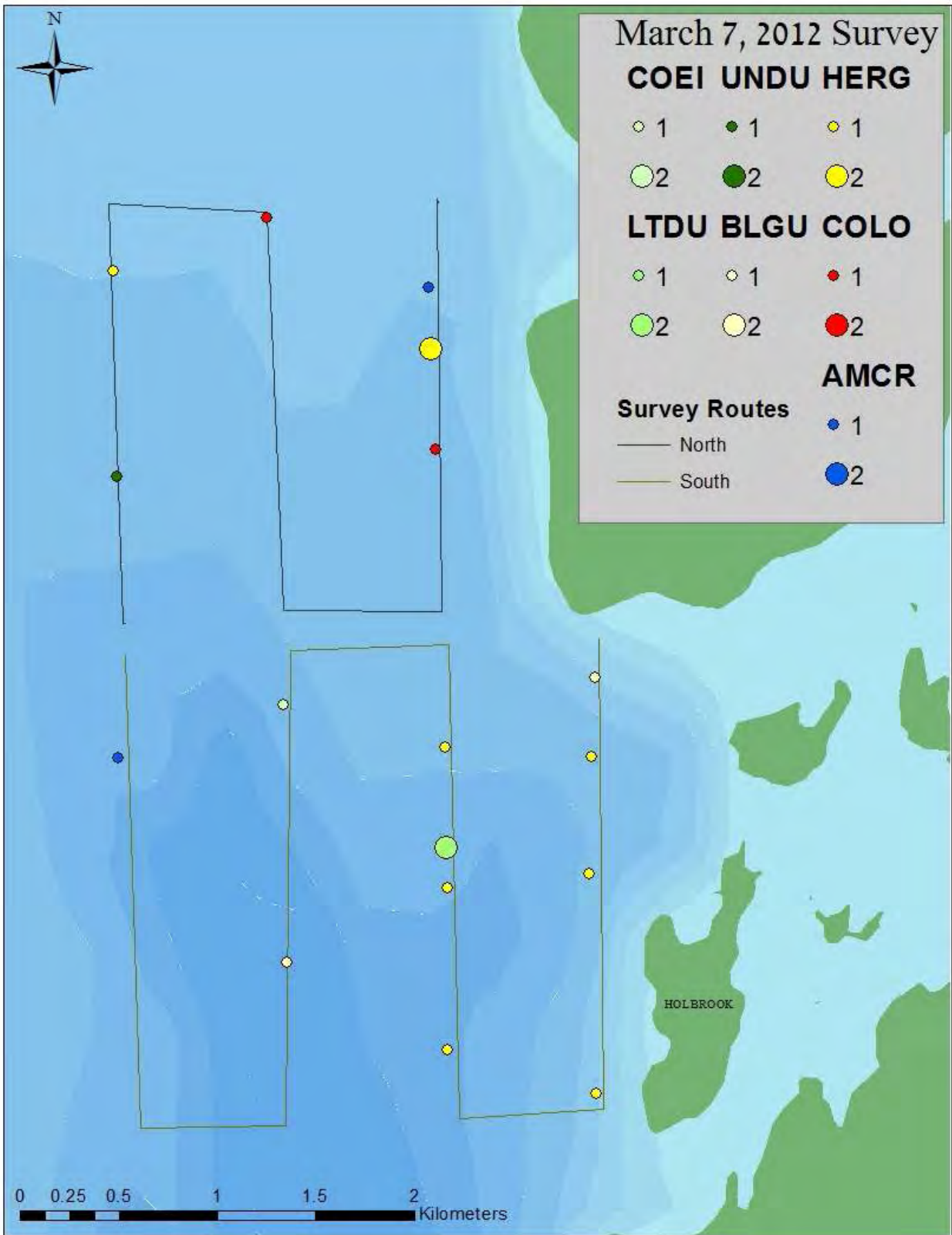
**MARCH 7, 2012**

**MORNING SURVEY (8:37 AM)**

Table 4. Numbers of species observed during the morning survey on March 7<sup>th</sup>.

<b>SPECIES</b>	<b>BR</b>	<b>SOUTH</b>	<b>NORTH</b>
American crow		2	1
Black guillemot		2	
Common eider		1	
Common loon		1	2
Herring gull		6	2
Long-tailed duck		1	
Unidentified duck			1
<b>TOTAL (1.31 birds/km<sup>2</sup>)</b>		<b>13</b>	<b>6</b>

On the morning of March 7<sup>th</sup>, conditions were rated “Fair” to “Average” due to the high seas (2-4ft) and strong winds (south, 16kts) with clear skies giving way to partly cloudy. Map 6 shows the general survey trackline with the location and number of animals recorded. This was the only survey day that did not include a transect on the Bagaduce River (BR) strip, therefore the total area surveyed consisted of 14.54km<sup>2</sup>. Nineteen total birds were observed (1.31 birds/km<sup>2</sup>) with 68% found in the South quadrat (Table 4). No marine mammals were observed this day, and the most common bird species found within the Castine Harbor Dice Head Test Site was the Herring gull (42%; 0.55 birds/km<sup>2</sup>).



Map 6. Bird observations on March 7, 2012.

Table 5. Species, behavior code, flight height, and flight direction on March 7<sup>th</sup>.

Behavior code	1	20										29	35		
Height (m)	0	1	2	3	10	20	30	35	40	50	10	2	10	15	
AMCR							1		1	1					
E										1					
ENE							1				1				
BLGU			2												
E				1											
ESE				1											
COEI			1												
NE				1											
COLO	2				1										
NW					1										
No direction	2														
HERG		2			1	1		1			1	1	1	1	
N								1						1	
NNW					1										
S												1			
SSW											1				
W		2										1			
No direction					1										
LTDU		2													
SSW		2													
UNDU	1														
No direction	1														
<b>Grand Total</b>	<b>3</b>	<b>2</b>	<b>2</b>	<b>3</b>	<b>2</b>	<b>1</b>	<b>1</b>	<b>1</b>	<b>1</b>	<b>1</b>	<b>1</b>	<b>1</b>	<b>1</b>	<b>1</b>	

Two Common loons (*Gavia immer*, coded as COLO) and one unidentified duck species (UNDU) were sitting on the water, and the remaining birds were in flight. Of the flying birds, 57% flew at a height of 10m or under. The American crows (*Corvus brachyrhynchos*, AMCR) and Herring gulls (*Larus argentatus*, HERG) were the species observed flying above 10m. Of the birds in flight, 14 (78%) flew in a direct path, one gull flew variable heights (under 10m) in a SSW direction, and three gulls (17%) demonstrated a milling flight behavior, often associated with foraging. Two Black guillemot (*Cephus grille*, BLGU), one Common eider (*Somateria mollissima*, COEI), and two Long-tailed ducks (*Clangula hyemalis*, LTDU) flew in a direct path at two and three meter's height.



# MARCH 16, 2012

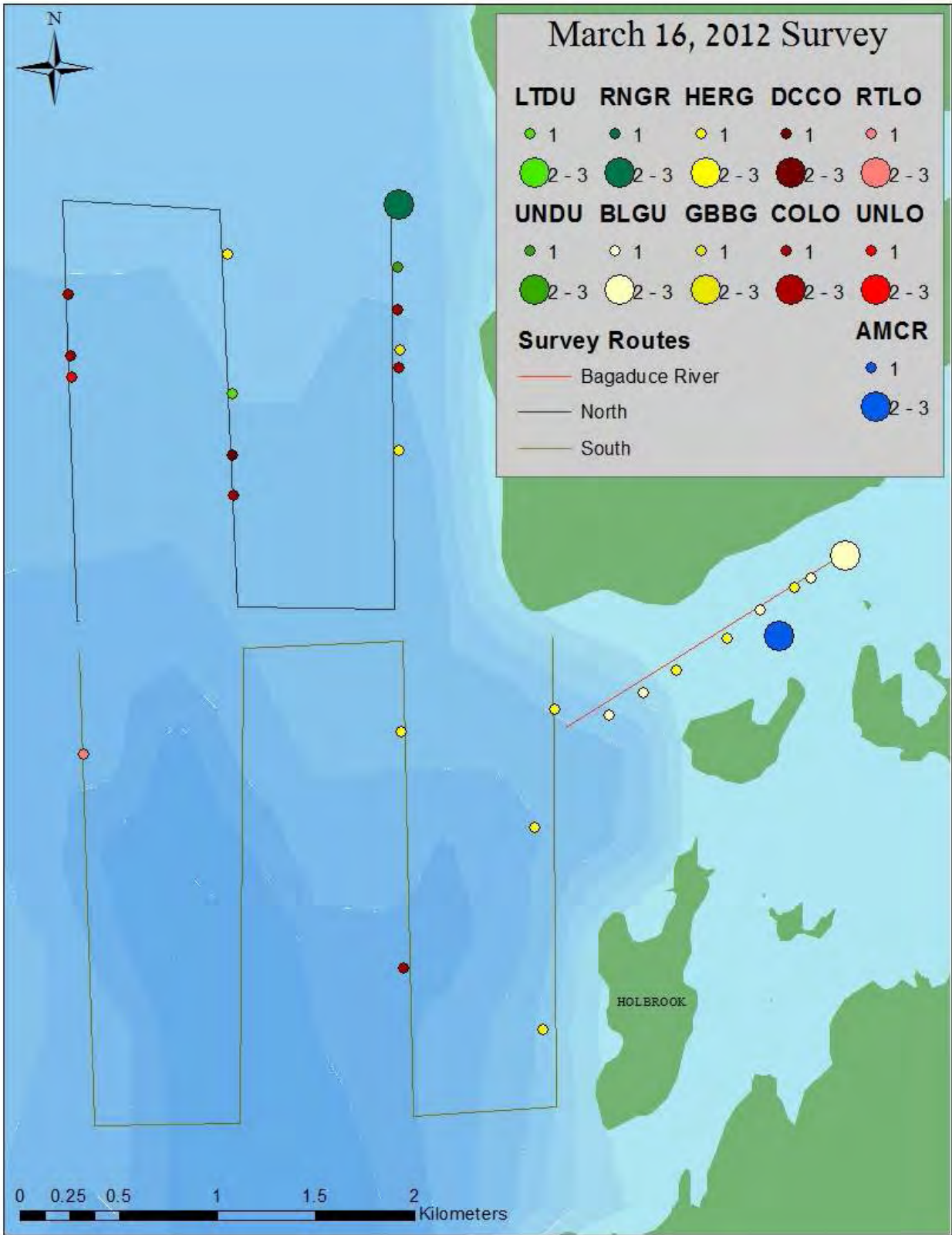
# AFTERNOON SURVEY (12:15 PM)

Table 6. Numbers of species observed during the afternoon survey on March 16<sup>th</sup>.

SPECIES	BR	SOUTH	NORTH
American crow	3		
Black guillemot	6		
Common loon		1	7
Double-crested cormorant			1
Great black-backed gull			1
Herring gull	3	4	2
Long-tailed duck			1
Red-necked grebe			2
Red-throated loon*		1	
Unidentified duck			2
Unidentified loon			1
Harbor seal			2
<b>TOTAL (2.17 birds/km<sup>2</sup>)</b>	<b>12</b>	<b>6</b>	<b>19</b>

\*Red text indicates Species of Conservation Concern.

In the afternoon on March 16<sup>th</sup>, conditions were rated “Excellent,” despite the light rain, with waves averaging under two feet, and wind around seven knots from the SE. Map 7 shows the survey’s tracks, which include the BR strip, and the wildlife observed and numbers by location. From this day onward, the total survey area covered 16.15km<sup>2</sup>. Thirty-five birds were recorded in this survey (2.17 birds/km<sup>2</sup>), with the addition of two Harbor seals (*Phoca vitulina*) found in the North quadrat (Table 6). The North quadrat included 49% of all birds observed with 34% found in the BR strip. Species composition in the North quadrat was also the highest, including nine total species compared to only three species in the BR and South quadrats. Herring gulls were the most numerous bird species overall (26%; 0.56 birds/km<sup>2</sup>), with COLO (23%; 0.5 birds/km<sup>2</sup>) and BLGU (17%; 0.37 birds/km<sup>2</sup>) as second and third most common species observed during this day’s survey.



Map 7. Bird observations on March 16, 2012.

Table 7. Species, behavior code, flight height, and flight direction on March 16<sup>th</sup>.

Behavior code	1	20								35			66			
Height (m)	0	1	3	5	30	35	40	45	5	10	15	0	15			
<b>AMCR</b>									3							
No direction									3							
<b>BLGU</b>	5	1														
SW		1														
No direction	5															
<b>COLO</b>	5	1	1	1												
N				1												
NNE			1													
W		1														
No direction	5															
<b>DCCO</b>													1			
No direction													1			
<b>GBBG</b>													1			
NE													1			
<b>HERG</b>		2		1			2		1	1	1	1				
ENE		1														
NW													2			
SSW		1														
WSW													1			
No direction													1	1	1	1
<b>LTDU</b>	1															
No direction	1															
<b>RNGR</b>	2															
No direction	2															
<b>RTLO*</b>													1			
<b>N</b>													1			
<b>UNDU</b>		2														
No direction		2														
<b>UNLO</b>		1														
No direction		1														
<b>Grand Total</b>	<b>13</b>	<b>7</b>	<b>1</b>	<b>1</b>	<b>1</b>	<b>1</b>	<b>2</b>	<b>1</b>	<b>4</b>	<b>1</b>	<b>1</b>	<b>1</b>	<b>1</b>			

\*Red text indicates Species of Conservation Concern.

Thirteen birds were observed sitting on the water, which included two Red-necked grebes (*Podiceps grisgena*, RNGR), one unidentified loon (UNLO), one LTDU, five BLGU, and five COLO. One Double-crested cormorant (*Phalacrocorax auritus*, DCCO) was sitting while feeding at the surface and one HERG landed on the water from an initial height of 15m to eat while sitting (Table 7). Of the flying birds, 70% flew at or under 10m, and three species (HERG; Great black-backed gull, *Larus marinus*, GBBG; and one Red-throated loon, *Gavia stellata*, RTLO) comprised the remaining 30% of birds that flew from 15m to 45m high.

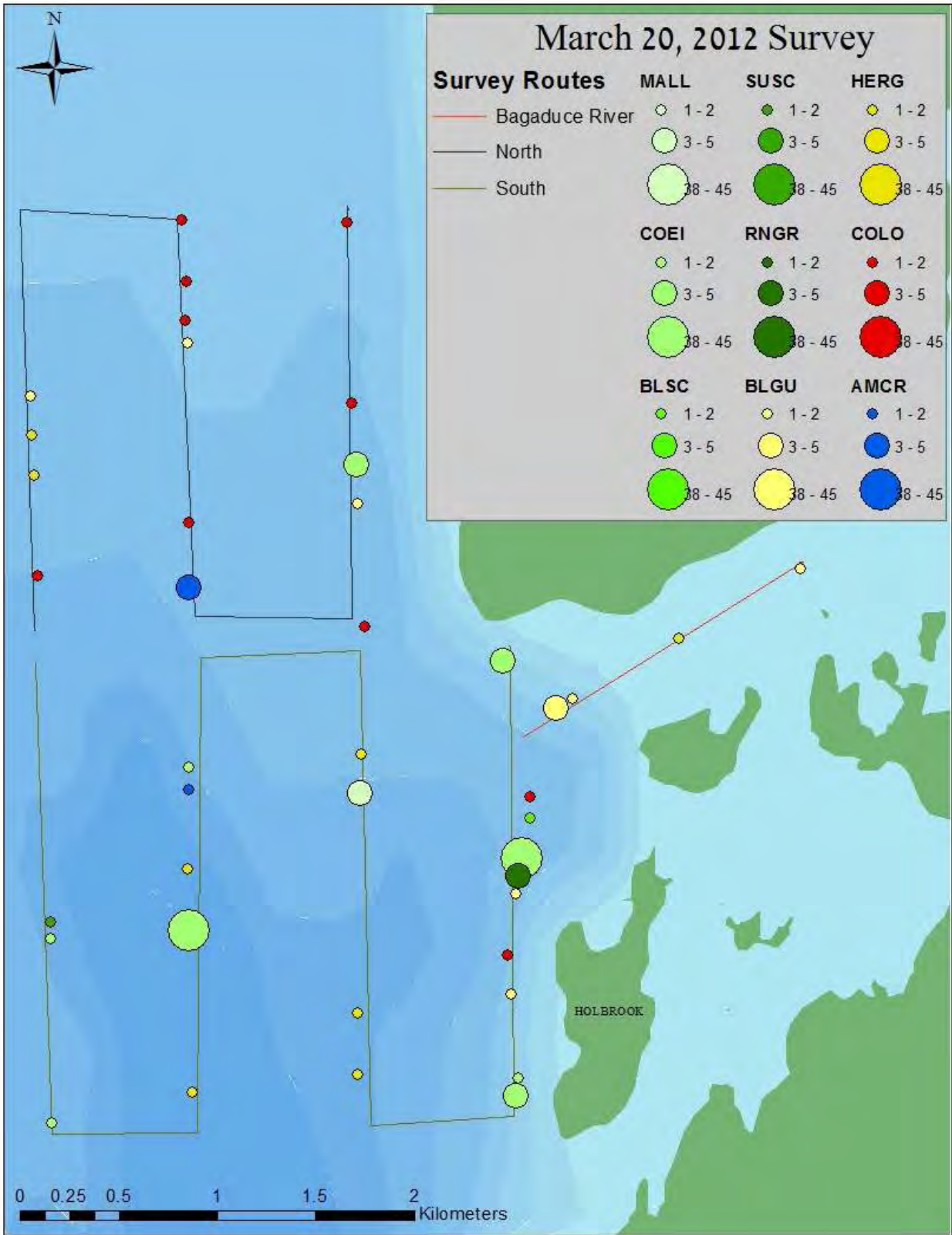
**MARCH 20, 2012**

**MORNING SURVEY (9:16 AM)**

Table 8. Numbers of species observed during the morning survey on March 20<sup>th</sup>.

SPECIES	BR	SOUTH	NORTH
American crow		2	4
Black guillemot	3	2	4
Black scoter		2	
Common eider		97	5
Common loon		2	8
Herring gull	2	6	2
Mallard		3	
Red-necked grebe		4	
Surf scoter		2	
Harbor porpoise		2	
Harbor seal		3	4
<b>TOTAL (9.29 birds/km<sup>2</sup>)</b>	<b>7</b>	<b>125</b>	<b>27</b>

The morning survey on March 20<sup>th</sup> was rated as “Maximum” conditions, with clear skies, seas averaging under two feet, and winds around seven knots from the SE. Map 8 shows the tracklines and wildlife observations. More total birds (150) were counted on this survey (9.29 birds/km<sup>2</sup>), particularly due to the high numbers of COEI (Table 8). Two Harbor porpoise (*Phocoena phocoena*) were observed in the South quadrat and seven total Harbor seals were observed in the South and North quadrats. Also, more total species and numbers of birds were observed in the South quadrat, with nine bird species and 120 total birds (80%) counted. Fifteen percent of the birds counted were located in the North quadrat and only five percent in the BR strip. Aside from the 102 COEI (68%; 7.43 birds/km<sup>2</sup>), the next most common species were 10 COLO (7%; 0.62 birds/km<sup>2</sup>) and 10 HERG (7%; 0.62 birds/km<sup>2</sup>), followed by nine BLGU (6%; 0.56 birds/km<sup>2</sup>) and six AMCR (4%; 0.37 birds/km<sup>2</sup>).



Map 8. Bird observations on March 20, 2012.

Table 9. Species, behavior code, flight height, and flight direction on March 20<sup>th</sup>.

Behavior code	1	20										32	66	70	
Height (m)	0	1	5	10	15	20	25	30	35	40	45	10	0	(below)	
<b>AMCR</b>							2	4							
E							4								
W							2								
<b>BLGU</b>	7													4	
No direction	7													4	
<b>BLSC</b>							2								
SSW							2								
<b>COEI</b>	51	44					2					5			
E							2								
N		1													
NE		4									5				
NW		38													
SSW		1													
No direction	51														
<b>COLO</b>	6	1	1										1	1	
WSW							1								
No direction	6	1										1	1		
<b>HERG</b>	3						1	4		1		1			
NE							3		1						
NNE							1		1						
S							1		1						
WSW							1								
No direction	3											1			
<b>MALL</b>		3													
SW		3													
<b>RNGR</b>	4														
No direction	4														
<b>SUSC</b>		2													
SW		2													
<b>Grand Total</b>	<b>71</b>	<b>46</b>	<b>1</b>	<b>3</b>	<b>4</b>	<b>2</b>	<b>2</b>	<b>4</b>	<b>4</b>	<b>1</b>	<b>5</b>	<b>1</b>	<b>1</b>	<b>5</b>	

Seventy-two birds (48%) were observed sitting on the water, which includes one single COLO eating while sitting on the water (Table 9). Four BLGU and one COLO were documented as actively diving below the surface from a sitting position, in the act of foraging, representing 3% of all birds observed. Of all the 73 flying birds, 70% were recorded at 10m or under. These included 44 COEI (38 were part of one flock flying NW at one meter high), three Mallards (*Anas platyrhynchos*, MALL) flying 10m high to the SW, two Surf scoters (*Melanitta perspicillata*, SUSC) flying SW one meter above the water, and one HERG curiously following a private boat at 10m. Species that flew above 10m included two Black scoters (*Melanitta nigra*, BLSC) at 15m, seven COEI (two at 20m heading E and five at 45m heading NE), four AMCR flying at 35m heading E, and six HERG flying at 15m, 30m, and 40m. Forty-eight percent of the birds were flying in a direct and consistent heading.

**MARCH 28, 2012**

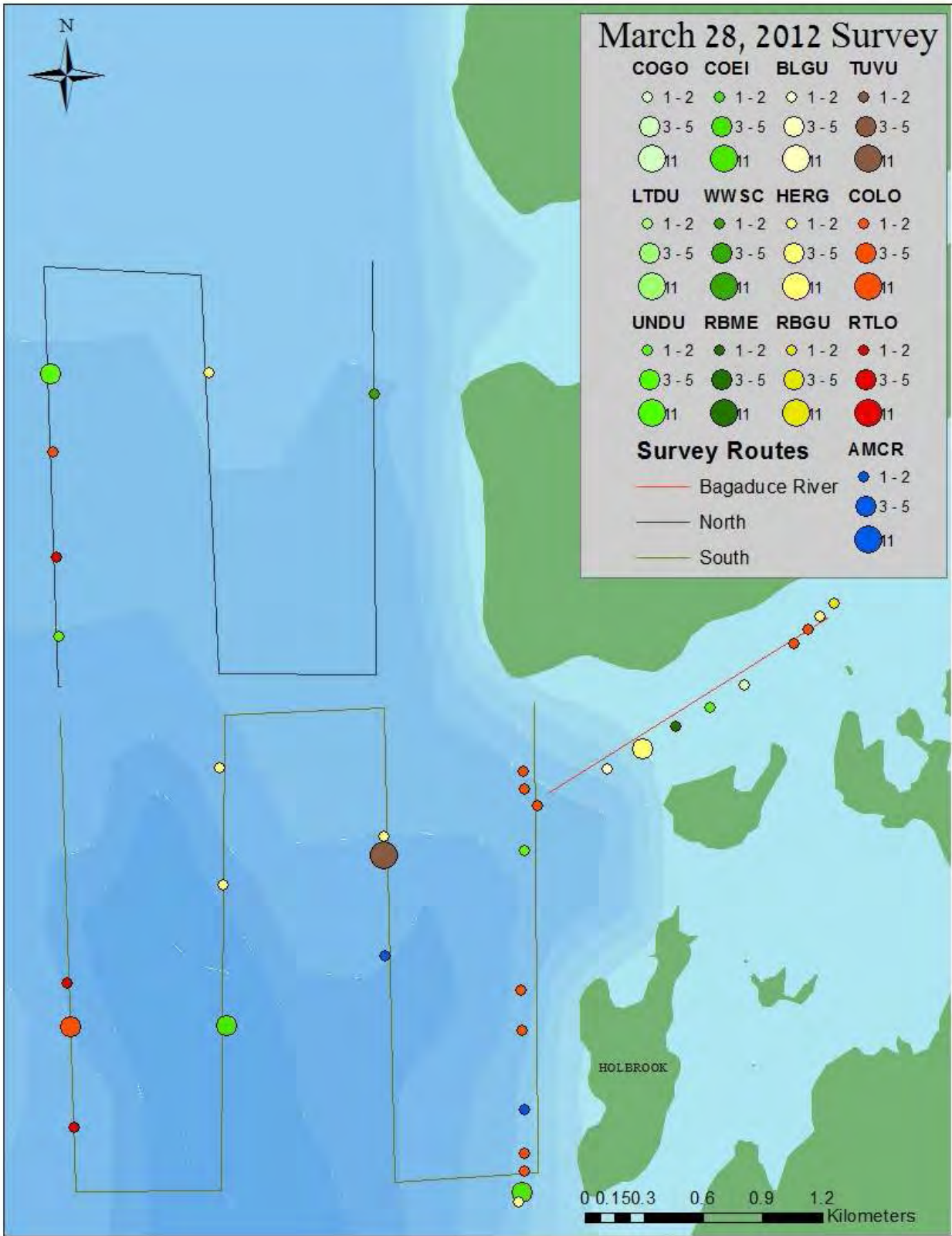
**AFTERNOON SURVEY (12:20 PM)**

Table 10. Numbers of species observed during the afternoon survey on March 28<sup>th</sup>.

SPECIES	BR	SOUTH	NORTH
American crow		2	
Black guillemot	1		
Common eider		8	
Common goldeneye	2		
Common loon	3	9	1
Herring gull	5	4	1
Long-tailed duck		2	
Ring-billed gull	2		
Red-breasted merganser	2		
Red-throated loon*		3	1
Turkey vulture		11	
Unidentified duck	1	1	4
White-winged scoter			1
Harbor porpoise		3	
<b>TOTAL (3.96 birds/km<sup>2</sup>)</b>	<b>16</b>	<b>43</b>	<b>8</b>

\*Red text indicates Species of Conservation Concern.

On the afternoon of March 28<sup>th</sup>, conditions were rated as “Maximum” initially, with overcast skies, seas no more than two feet, and ESE winds at seven knots, but halfway through the survey, conditions turned to snow and reduced the rating a notch to “Excellent.” Map 9 shows the tracklines and wildlife observations. A total of 64 birds was recorded (3.96 birds/km<sup>2</sup>) with three Harbor porpoise observed in the South quadrat (Table 10). Fourteen species were recorded on this day, which is the third highest count for the season. Sixty-three percent of the birds were found in the South quadrat, 25% in the BR, and 13% in the North quadrat. The most common species included 13 COLO (20%; 0.8 birds/km<sup>2</sup>), 11 Turkey vultures (*Cathartes aura*, TUVU) (17%; 0.68 birds/km<sup>2</sup>), 10 HERG (16%; 0.62 birds/km<sup>2</sup>), and eight COEI (13%; 0.5 birds/km<sup>2</sup>).



Map 9. Bird observations on March 28, 2012.



Table 11. Species, behavior code, flight height, and flight direction on March 28<sup>th</sup>.

Behavior code	1	20						35				48		70			
Height (m)	0	1	3	5	10	15	20	25	5	10	20	35	7	50	(below)		
AMCR		1			1												
W		1			1												
BLGU	1																
No direction	1																
COEI	8																
No direction	8																
COGO		2															
ESE		2															
COLO	9	3														1	
ENE		3															
No direction	9															1	
HERG	1	3			2		1		1		1		1				
NE		3											1				
No direction	1				2		1		1		1						
LTDU	2																
No direction	2																
RBGU												2					
No direction												2					
RBME																2	
No direction																2	
RTLO*	1	1	1	1													
NNE		1		1													
W		1															
No direction	1																
TUVU														11			
No direction														11			
UNDU		2	1	3													
E		1															
NE		1															
NNW		3															
WNW		1															
WWSC		1															
S		1															
<b>Grand Total</b>	<b>22</b>	<b>6</b>	<b>2</b>	<b>4</b>	<b>3</b>	<b>4</b>	<b>1</b>	<b>2</b>	<b>1</b>	<b>1</b>	<b>2</b>	<b>1</b>	<b>1</b>	<b>11</b>	<b>3</b>		

\*Red text indicates Species of Conservation Concern.

Representing nine bird species, 22 total birds (34%) were sitting on the water, and five percent of the total birds were actively foraging under the water, which included one COLO and two Red-breasted mergansers (*Mergus serrator*, RBME) (Table 11). Thirty-four percent of all the birds were in direct flight, 19% were flying in a meandering path, and eight percent were milling, as if looking to forage. Of the flying birds, 46% flew 10m or under. These species included one AMCR, three HERG, three COLO and two RTLO, and multiple duck species such as two Common goldeneye (*Bucephala clangula*, COGO), one White-winged scoter (*Melanitta fusca*, WWSC), and six unidentified ducks (UNDU). Species recorded flying above 10m included one AMCR flying W at 20m, five HERG flying straight at 15m, 25m, and one milling at 35m, two Ring-billed gulls (*Larus delawarensis*, RBGU) milling at 20m, one RTLO flying direct NNE at 15m, and 11 TUVU meandering at a height of 50m located in the updrafts near the edge of Dice's Head on the mainland.

APRIL 4, 2012

MORNING SURVEY (8:16 AM)

Table 12. Numbers of species observed during the morning survey on April 4<sup>th</sup>.

SPECIES	BR	SOUTH	NORTH
Black guillemot	1		
Black scoter		1	
Common eider	2	29	60
Common goldeneye			2
Common loon	1	2	3
Herring gull		6	1
Red-necked grebe			2
Red-throated loon*			2
Snow bunting			2
Surf scoter			2
Unidentified duck	3		
Harbor porpoise	1	1	1
<b>TOTAL (8.37 birds/km<sup>2</sup>)</b>	<b>8</b>	<b>39</b>	<b>75</b>

\*Red text indicates Species of Conservation Concern.

On the morning of April 4<sup>th</sup>, conditions were rated as “Maximum” with clear skies, seas no more than two feet, and N winds averaging seven knots. Map 10 shows the tracklines and wildlife observations, in which one of the four transects within the South quadrat was lost due to equipment malfunction. The survey area covered in the South quadrat was 6.3km<sup>2</sup>, making the total area covered for the day 14.21km<sup>2</sup>. A total of 119 birds (8.37 birds/km<sup>2</sup>) were recorded, with three total Harbor porpoise observed, one found in each survey quadrat and BR strip (Table 12). Seventy-four birds (62%) representing eight different species were observed in the North quadrat, 38 birds (32%) with only four species represented were observed in the South quadrat, and the remaining four species totaling seven birds (6%) were observed in the BR. The most common species recorded were 91 COEI (76%; 6.4 birds/km<sup>2</sup>), seven HERG (6%; 0.5 birds/km<sup>2</sup>), and six COLO (5%; 0.42 birds/km<sup>2</sup>).

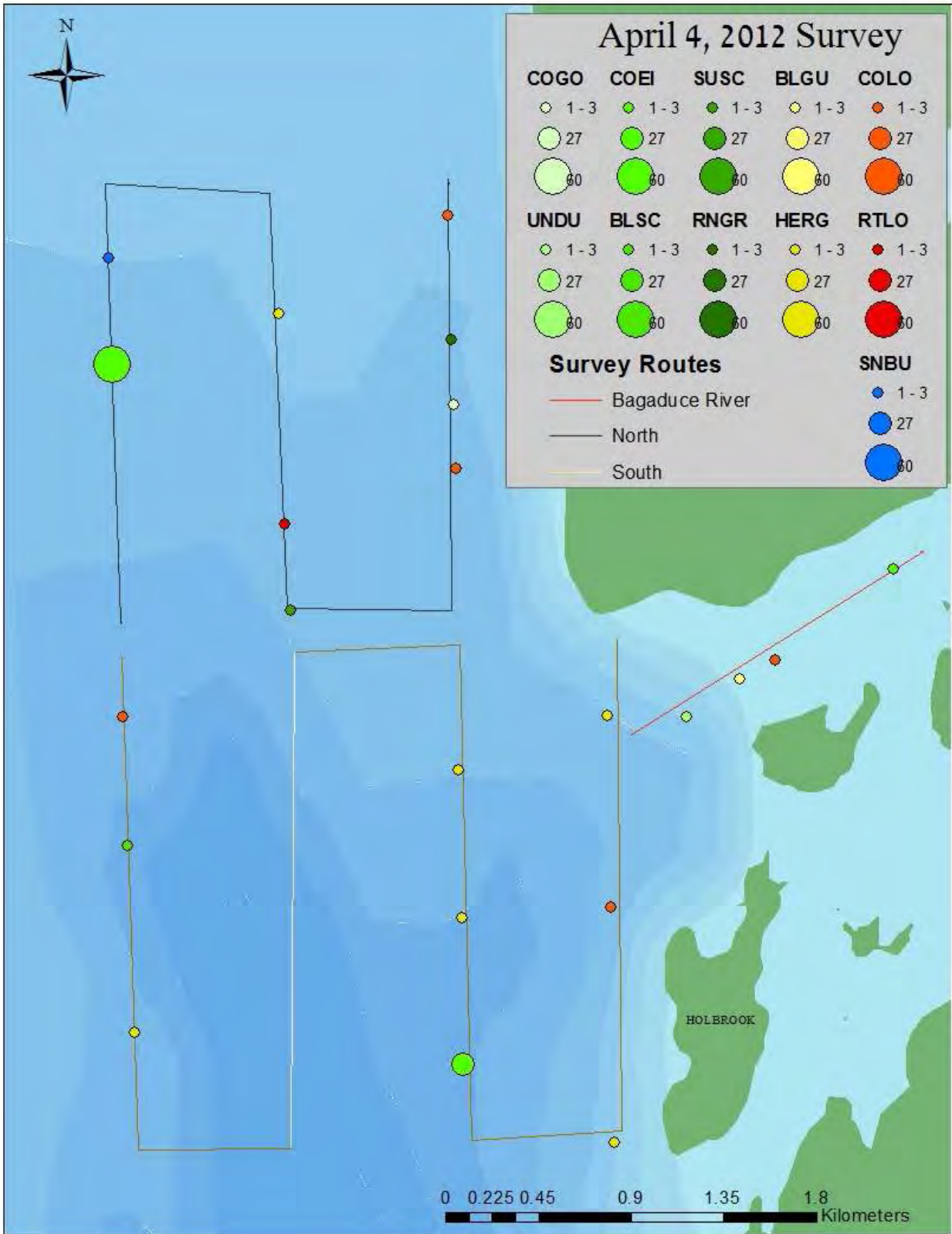


Table 13. Species, behavior code, flight height, and flight direction on April 4<sup>th</sup>.

Behavior code	1	20							70
Height (m)	0	1	2	5	10	20	30	50	(below)
<b>BLGU</b>	<b>1</b>								
No direction	1								
<b>BLSC</b>	<b>1</b>								
No direction	1								
<b>COEI</b>	<b>29</b>	<b>60</b>	<b>2</b>						
N		60	2						
No direction	29								
<b>COGO</b>			<b>2</b>						
N			2						
<b>COLO</b>	<b>6</b>								
No direction	6								
<b>HERG</b>	<b>2</b>			<b>2</b>		<b>1</b>	<b>2</b>		
ENE									
NNE								2	
NW							1		
W					1				
WNW					1				
No direction	2								
<b>RNGR</b>	<b>2</b>								
No direction	2								
<b>RTLO*</b>	<b>1</b>								<b>1</b>
No direction	1								1
<b>SNBU</b>						<b>2</b>			
N						2			
<b>SUSC</b>			<b>2</b>						
NW			2						
<b>UNDU</b>	<b>3</b>								
No direction	3								
<b>Grand Total</b>	<b>45</b>	<b>60</b>	<b>2</b>	<b>4</b>	<b>2</b>	<b>2</b>	<b>1</b>	<b>2</b>	<b>1</b>

\*Red text indicates Species of Conservation Concern.

Forty-five birds (38%) represented by eight different species were sitting on the water and one RTLO was actively diving below the surface in pursuit of prey (Table 13). All flying birds in this day's survey were demonstrating direct flight, with 93% flying ≤10m and 85% of these birds were COEI, heading N. Other low-flying species included two COGO, two SUSC, and two HERG. Bird species flying greater than 10m included two Snow buntings (*Plectrophenax nivalis*, SNBU) flying N at 20m, and three HERG at 30m and 50m.

APRIL 12, 2012

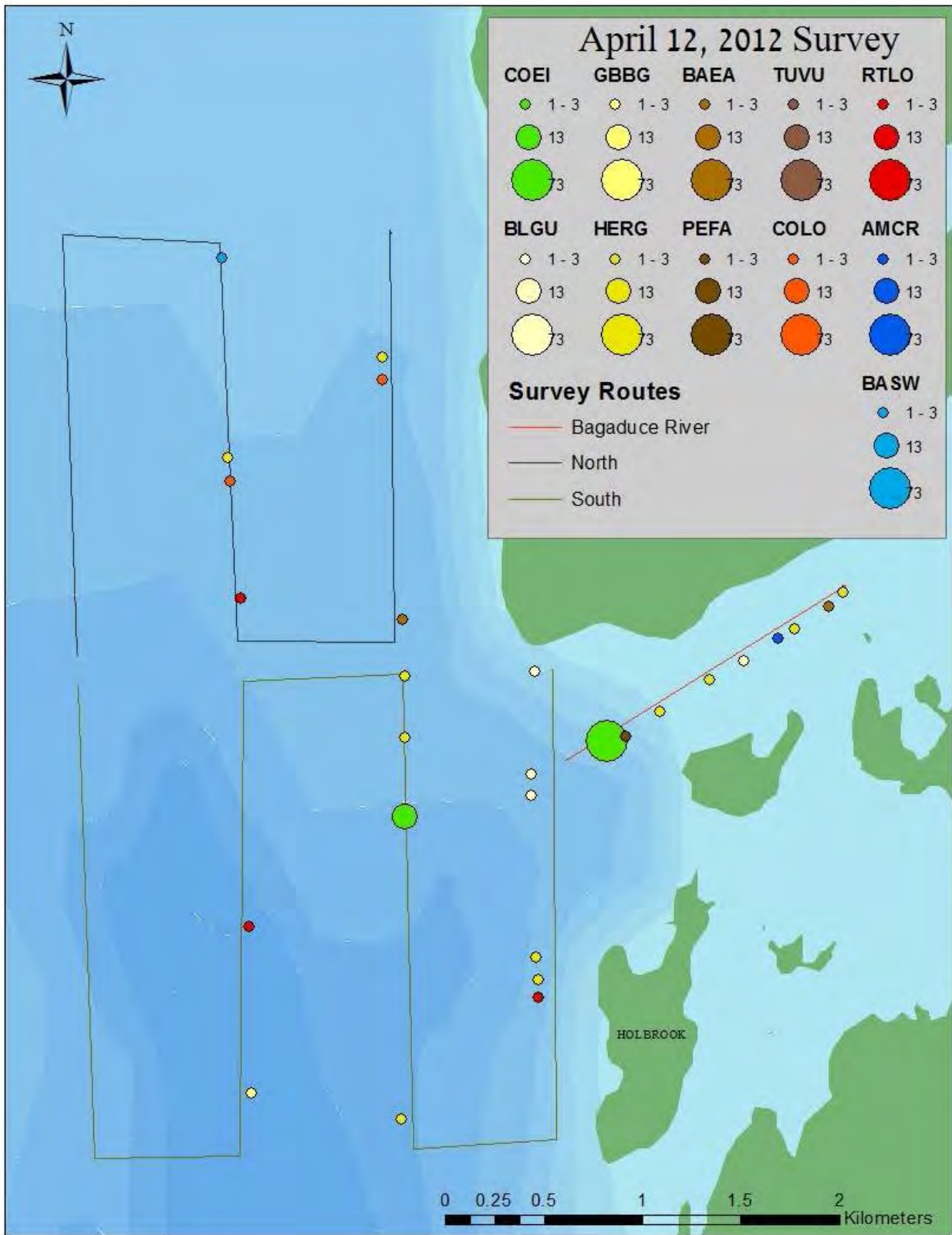
MORNING SURVEY (9:00 AM)

Table 14. Numbers of species observed during the morning survey on April 12<sup>th</sup>.

SPECIES	BR	SOUTH	NORTH
American crow	1		
Bald eagle*	1		1
Barn swallow			1
Black guillemot	1	3	
Common eider	76	13	
Common loon			2
Great black-backed gull		1	
Herring gull	11	5	2
Peregrine falcon*	1		
Red-throated loon*		2	1
Turkey vulture	2		
Harbor seal		1	
<b>TOTAL (7.68 birds/km<sup>2</sup>)</b>	<b>93</b>	<b>25</b>	<b>7</b>

\*Red text indicates Species of Conservation Concern.

On the morning of April 12<sup>th</sup>, conditions were rated as “Excellent” with waves not over two feet, winds around 12kts from the north, and clear skies changing to partly cloudy. Map 11 shows the tracklines and wildlife observations. A total of 124 birds (7.68 birds/km<sup>2</sup>) and one Harbor seal were observed (Table 14). The BR strip had the most birds with 75% recorded, the South quadrat had 19%, and the North quadrat had only 6%. The one Harbor seal was also found in the South quadrat. Common eider were the most abundant species by far (72%; 5.51 birds/km<sup>2</sup>), and HERG were second most abundant (15%; 1.11 birds/km<sup>2</sup>).



Map 11. Bird observations on April 12, 2012.

Table 15. Species, behavior code, flight height, and flight direction on April 12<sup>th</sup>.

Behavior code	1	20						29	35					48	
Height (m)	0	1	2	5	15	20	30	<5	10	15	20	35	40	50	15
<b>AMCR</b>															1
No direction															1
<b>BAEA*</b>						2									
<b>NNW</b>						1									
<b>SSE</b>						1									
<b>BASW</b>			1												
E			1												
<b>BLGU</b>	2	2													
ESE		1													
No direction	2	1													
<b>COEI</b>	73	13	3												
E		13													
S			3												
No direction	73														
<b>COLO</b>	1	1													
NE		1													
No direction	1														
<b>GBBG</b>								1							
W								1							
<b>HERG</b>	6	1			1	1	1	1	2	1	1		1	2	
NNE						1		1							
SSW		1													
SW					1		1								
No direction	6								2	1	1		1	2	
<b>PEFA*</b>							1								
<b>S</b>							1								
<b>RTLO*</b>	1	1	1												
<b>NNE</b>		1													
<b>SE</b>			1												
No direction	1														
<b>TUVU</b>												2			
No direction												2			
<b>Grand Total</b>	<b>83</b>	<b>18</b>	<b>2</b>	<b>3</b>	<b>1</b>	<b>3</b>	<b>2</b>	<b>2</b>	<b>2</b>	<b>1</b>	<b>1</b>	<b>2</b>	<b>1</b>	<b>2</b>	<b>1</b>

\*Red text indicates Species of Conservation Concern.

Of all the birds observed, 67% were sitting on the water (Table 15). Of all the flying birds, 71% were flying in a direct heading, two gulls (5%) were flying variable heights under five meters, nine HERG (22%) were milling, and one AMCR was demonstrating meandering flight at 15m high. Sixty-six percent of all flying birds were ≤10m, and included one Barn swallow (*Hirundo rustica*, BASW) flying two meters high heading E, two BLGU flying one meter high, a single flock of COEI males and females flying E at one meter and another observation of three COEI flying five meters high and heading S, four HERG and one GBBG demonstrating direct flight, variable flight, and milling, and two RTLO at one meter and another at two meters high. The species that flew above 10m included HERG and two observations of a Bald eagle (*Haliaeetus leucocephalus*, BAEA), both flying 20 meters, but one heading NNW along the BR, and one flying SSE along the edge of Dice's Head. Also found flying at 30m was a Peregrine falcon (*Falco peregrines*, PEFA) heading S along the BR.

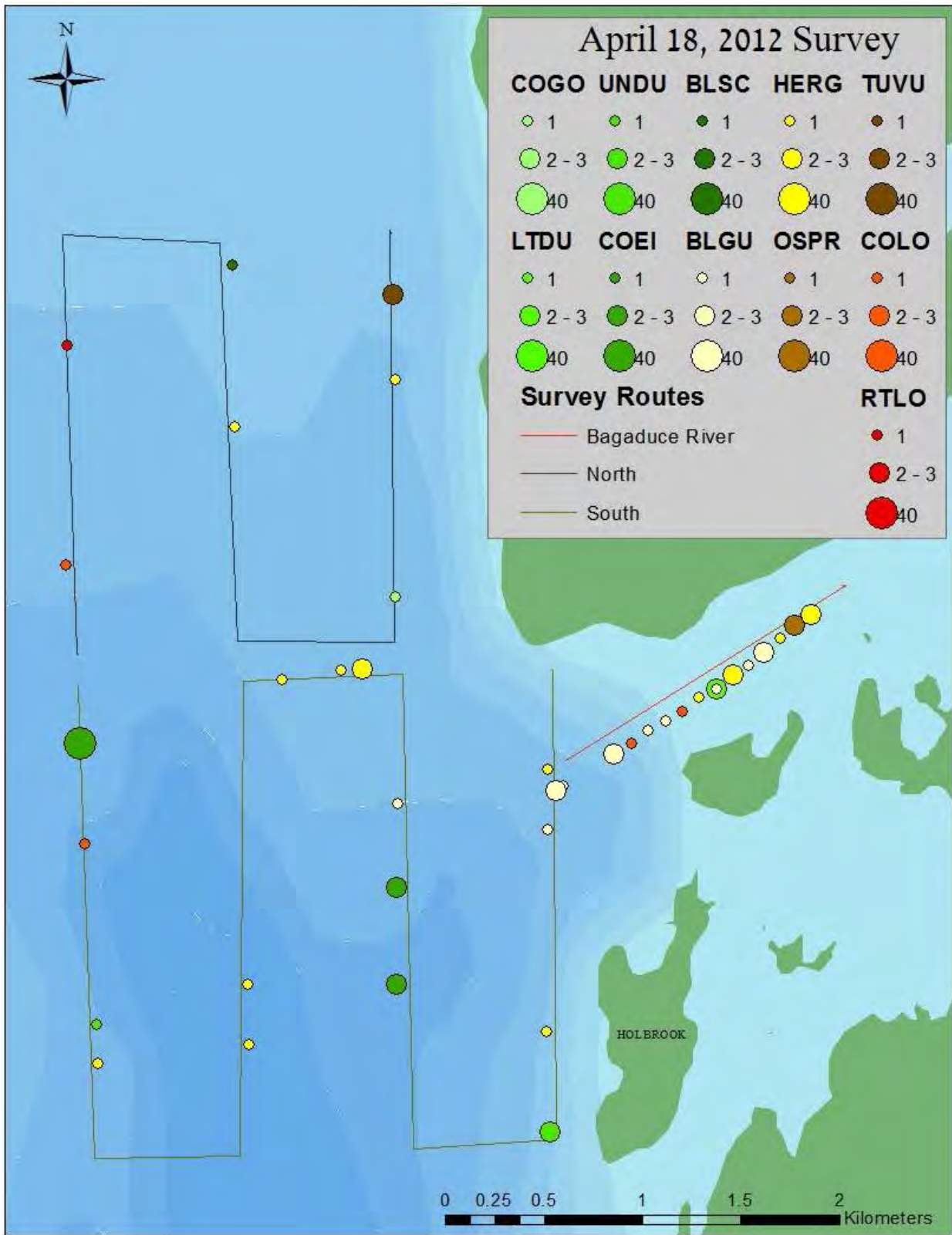
Table 16. Numbers of species observed during the afternoon survey on April 18<sup>th</sup>.

SPECIES	BR	SOUTH	NORTH
Black guillemot	13	3	
Black scoter			1
Common eider		44	
Common goldeneye			1
Common loon	2	1	1
Herring gull	11	5	7
Long-tailed duck	3		
Osprey	2		
Red-throated loon*			1
Turkey vulture			3
Unidentified duck		3	
Harbor seal		2	3
<b>TOTAL (6.25 birds/km<sup>2</sup>)</b>	<b>31</b>	<b>58</b>	<b>17</b>

\*Red text indicates Species of Conservation Concern.

During the afternoon survey of April 18<sup>th</sup>, the conditions were rated as “Maximum” with clear skies, winds around seven knots from the WNW changing to NNW, and seas no more than two feet. Map 12 shows the tracklines and wildlife observations. A total of 101 birds were observed (6.25 birds/km<sup>2</sup>) and five Harbor seals were also observed, with two in the South quadrat and three in the North (Table 16). Of all the birds observed, 55% were recorded in the South quadrat, 31% in the BR, and 14% were recorded in the North quadrat. Again, the COEI were the most abundant (44%; 2.72 birds/km<sup>2</sup>) and HERG were second most abundant (33%; 1.42 birds/km<sup>2</sup>), with numbers of BLGU representing 16% of all birds recorded (0.99 birds/km<sup>2</sup>).





Map 12. Bird observations on April 18, 2012.

Table 17. Species, behavior code, flight height, and flight direction on April 18<sup>th</sup>.

Behavior code	1	20					32	35					70		
Height (m)	0	1	10	15	25	30	20	5	10	15	25	40	45	(below)	
<b>BLGU</b>	11	2													3
W		1													
No direction	11	1													3
<b>BLSC</b>		1													
S		1													
<b>COEI</b>	40	2		2											
E		2													
NNW															
No direction	40														
<b>COGO</b>	1														
No direction	1														
<b>COLO</b>	4														
No direction	4														
<b>HERG</b>	7	1	2	1	1	2	1	2	2	1		2	1		
E		1		1											
ENE															
NE		1		1											
No direction	7	1				1	1	2	2	1		2	1		
<b>LTDU</b>	3														
No direction	3														
<b>OSPR</b>											2				
No direction											2				
<b>RTLO*</b>	1														
No direction	1														
<b>TUVU</b>														3	
No direction														3	
<b>UNDU</b>	2	1													
N		1													
No direction	2														
<b>Grand Total</b>	69	7	2	3	1	2	1	2	2	1	2	2	4	3	

Of all the birds observed, 68% were sitting on the water, which included four duck species, BLGU, and two loon species (Table 17). Three BLGU (3%) were actively diving below the surface, from a sitting position, in search of prey. The majority of flying birds were demonstrating direct flight (52%), while 45% were milling. These included eight HERG at various heights, two OSPR (*Pandion haliaetus*, OSPR) at 35m, and three TUVU at 45m. One HERG followed our research vessel at a height of 20m before wandering away. Three duck species, two BLGU, and three HERG, representing 38% of all flying birds, were observed flying ≤10m. Flying above 10m were the OSPR, TUVU, two COEI at 15m flying NNW, and four HERG with direct flight ranging from 15m to 30m, the boat-following HERG at 20m, and four HERG meandering at heights of 15m to 45m.

Table 18. Numbers of species observed during the morning survey on April 28<sup>th</sup>.

SPECIES	BR	SOUTH	NORTH
Black guillemot	1		
Double-crested cormorant	3		
Herring gull	7	4	1
Red-throated loon*			1
<b>TOTAL (2.0 birds/km<sup>2</sup>)</b>	<b>13</b>	<b>4</b>	<b>2</b>

\*Red text indicates Species of Conservation Concern.

The morning survey on April 28<sup>th</sup> experienced unfortunate equipment malfunction and the first three transect strips of the four total that comprise the South quadrat were lost. Therefore, the data in the South quadrat reflect only a survey area coverage of 1.61km<sup>2</sup> with a complete survey area for the day totaling 9.52km<sup>2</sup>. Conditions were rated as “Excellent” with seas from two to four feet, winds around 16kts from the NW changing to W, and clear skies giving way to partly cloudy. Map 13 shows the modified tracklines and the wildlife observations. Only 19 birds were recorded (1.84 birds/km<sup>2</sup>) and no marine mammals (Table 18). The majority of birds were observed in the BR with 68%, and despite only the single strip of data successfully recorded in the South quadrat, four birds (21%) were observed, compared to the full area of the North quadrat, with only two birds (11%). Herring gulls were the most abundant bird species (63%; 1.26 birds/km<sup>2</sup>).

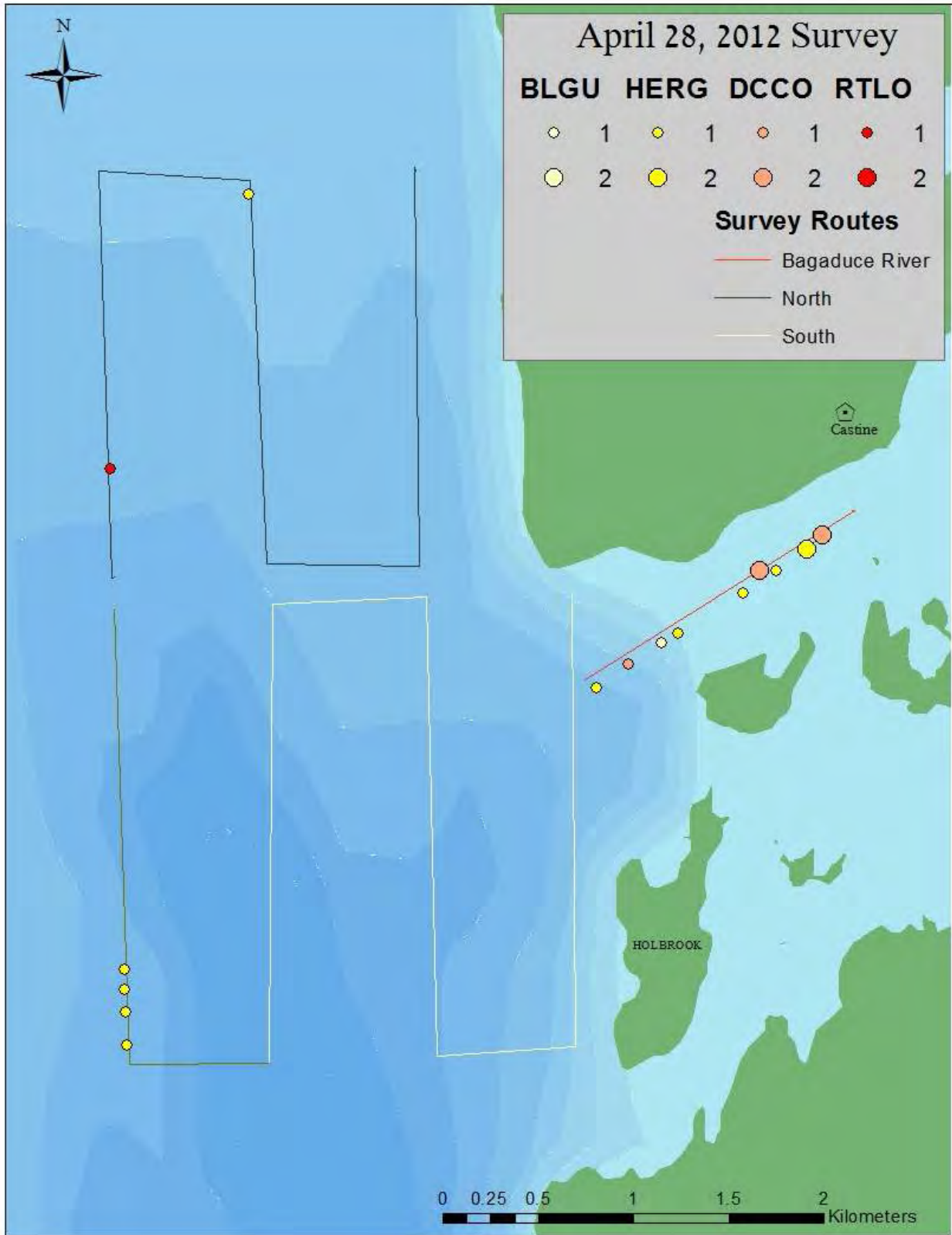


Table 19. Species, behavior code, flight height, and flight direction on April 28<sup>th</sup>.

Behavior code	1	20	29	35	48					
Height (m)	0	1	1	3	5	15	<5	5	1	15
<b>BLGU</b>	1									
No direction	1									
<b>DCCO</b>	2	2	1							
N			1							
S		2								
No direction	2									
<b>HERG</b>	1	3	2	1	1	2	1	2	1	1
N			1							
NE							1			
W		1	1							
WSW		2								
No direction	1				1			2	1	1
<b>RTLO*</b>			1							
<b>NW</b>			1							
<b>Grand Total</b>	2	2	5	1	3	1	1	2	1	1

\*Red text indicates Species of Conservation Concern.

One BLGU and one HERG were sitting on the water but two DCCO were observed flying initially at one meter before landing on the water to sit (Table 19). These four sitting birds comprised 21% of all bird observations. Of all the flying birds, 67% demonstrated direct flight, 13% were milling as if to forage, 13% were meandering, and a single HERG flew with variable height under five meters heading NE. The majority of birds (87%) flew ≤10m, which included eight HERG, one RTLO flying NW at three meters and three DCCO, two at one meter and one at five meters. Flying above 10m were two HERG both at 15m, one flying direct and one meandering.

May 4, 2012

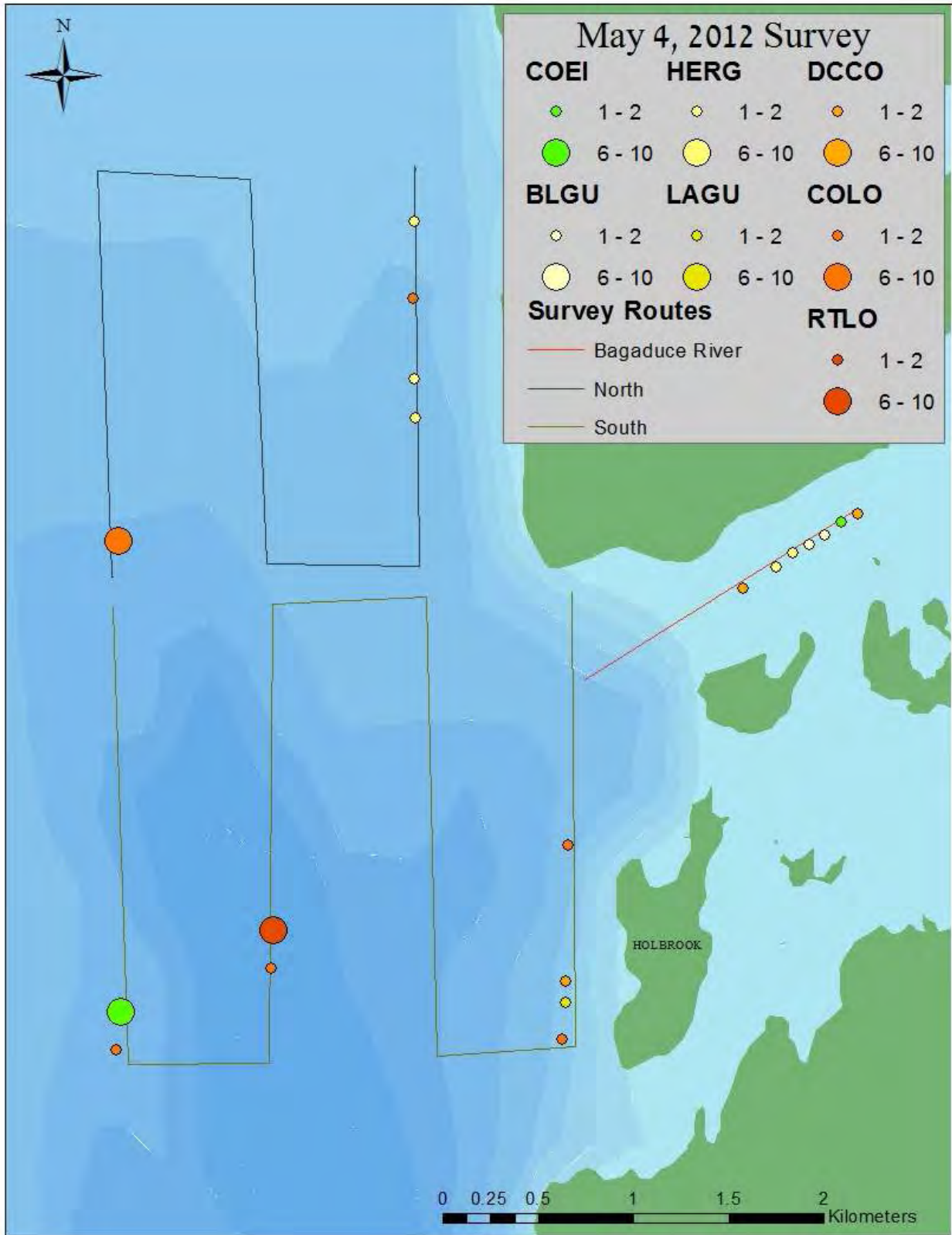
MORNING SURVEY (8:20 AM)

Table 20. Numbers of species observed during the morning survey on May 4<sup>th</sup>.

SPECIES	BR	SOUTH	NORTH
Black guillemot	2		
Common eider	4	10	
Common loon		5	11
Double-crested cormorant	3	1	
Herring gull	4		3
Laughing gull		1	
Red-throated loon*		6	
Harbor seal	1	6	3
<b>TOTAL (3.1 birds/km<sup>2</sup>)</b>	<b>14</b>	<b>29</b>	<b>17</b>

\*Red text indicates Species of Conservation Concern.

On the morning survey of May 4<sup>th</sup>, conditions were rated as “Excellent” with a slight ripple on the water, reducing to flat calm, S winds around five knots, and a light rain. Map 14 shows the tracklines and wildlife observations, and from this point until the end of the survey season, the total survey area coverage will remain 16.15km<sup>2</sup>. A total of 50 birds (3.1 birds/km<sup>2</sup>) and 10 Harbor seals were observed throughout the day (Table 20). Forty-six percent of birds were recorded in the South quadrat, 28% in the North, and 26% in the BR. The majority of Harbor seals (60%) were seen in the South quadrat and 30% were seen in the North, with one found in the BR. Common loons were the most common bird species (32%; 0.99 birds/km<sup>2</sup>), followed by COEI (28%; 0.87 birds/km<sup>2</sup>), HERG (14%; 0.43 birds/km<sup>2</sup>), and then RTLO (12%; 0.37 birds/km<sup>2</sup>).



Map 14. Bird observations on May 4, 2012.

Table 21. Species, behavior code, flight height, and flight direction on May 4<sup>th</sup>.

Behavior code	1	20					35			48
Height (m)	0	1	2	10	15	40	10	30	35	
<b>BLGU</b>	2									
(blank)	2									
<b>COEI</b>	14									
(blank)	14									
<b>COLO</b>	15	1								
N		1								
(blank)	15									
<b>DCCO</b>	3	1								
SE		1								
(blank)	3									
<b>HERG</b>		1		1	1	2	1	1		
N					1					
S		1		1						
(blank)						2	1	1		
<b>LAGU</b>		1								
S		1								
<b>RTLO*</b>	6									
(blank)	6									
<b>Grand Total</b>	40	2	1	1	1	1	2	1	1	

\*Red text indicates Species of Conservation Concern.

Eighty percent of all birds were sitting on the water, which included multiple large groups of 10 COEI, 10 COLO, and six RTLO in three separate observations, among other single bird observations of BLGU and DCCO (Table 21). Of the flying bird, 60% were flying direct, 30% were milling as if to forage, and only one HERG meandered 35m high. Flying ≤10m were 60% of the observations, which included one COLO flying N and one DCCO flying SE each at one meter, and one HERG at two meters and one Laughing gull (*Leucophaeus atricilla*, LAGU) flying at 10m, both heading S. All birds that flew above 10m were HERG, demonstrating direct flight, milling, and meandering from heights of 15m to 40m.



**MAY 7, 2012**

**AFTERNOON SURVEY (12:28 PM)**

Table 22. Numbers of species observed during the afternoon survey on May 7<sup>th</sup>.

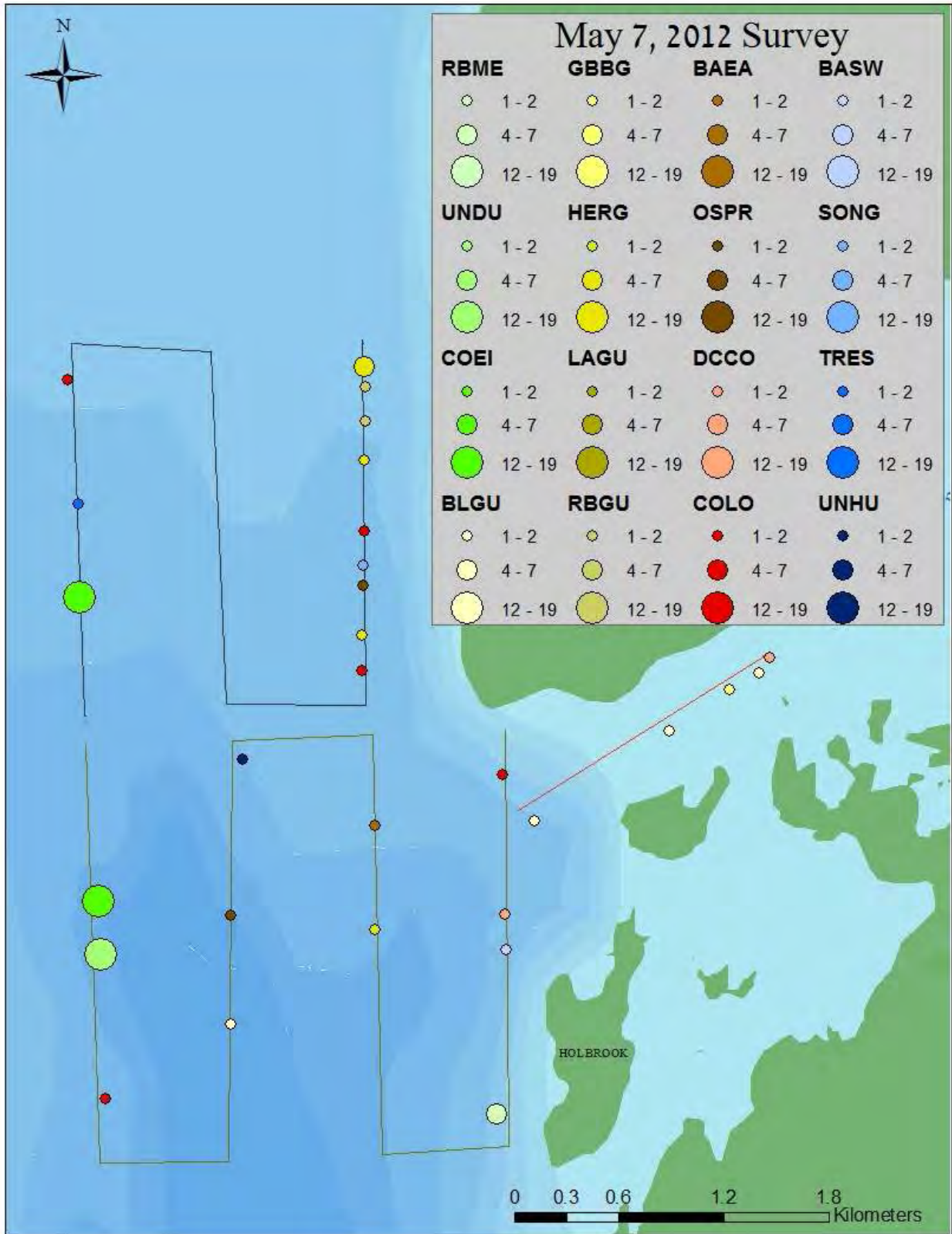
SPECIES	BR	SOUTH	NORTH
Bald eagle*		1	
Barn swallow		2	
Black guillemot	3	1	
Common eider		15	12
Common loon		2	5
Double-crested cormorant	2	1	
Great black-backed gull	1		
Herring gull		1	9
Laughing gull			2
Osprey		1	1
Ring-billed gull			2
Red-breasted merganser		4	7
Unidentified songbird			2
Tree swallow			1
Unidentified duck		19	
Unidentified hummingbird		1	
Harbor porpoise		2	
Harbor seal	2	4	1
<b>TOTAL (5.94 birds/km<sup>2</sup>)</b>	<b>8</b>	<b>54</b>	<b>42</b>

\*Red text indicates Species of Conservation Concern.

During the afternoon survey of May 7<sup>th</sup>, conditions were rated as “Maximum” due to clear skies, a slight ripple on the water, and winds averaging four knots from the N. Map 15 shows the tracklines and wildlife observations. A total of 96 birds (5.94 birds/km<sup>2</sup>) and eight marine mammals were recorded throughout the day (Table 22). Although the total bird count was not the highest of any of the surveys, 18 different species were observed, making it the highest species tally day of the season. Exactly 50% of all birds were recorded in the South quadrat, 43% in the North, and only six birds (6%) were observed in the BR. The majority of the marine mammals were also found in the South quadrat, with 57% of the Harbor seals and the only two Harbor porpoise. Two Harbor seals (29%) were observed in the BR, with only one in the North quadrat. The most abundant species were again the COEI (28%; 1.67 birds/km<sup>2</sup>) and HERG (10%; 0.62 birds/km<sup>2</sup>), but also large numbers of RBME (11%; 0.68 birds/km<sup>2</sup>) and one raft of an unidentified duck species (20%; 1.18 birds/km<sup>2</sup>). This is the last day of the season that the COEI were present to document.

The majority of the total birds observed (80%) were sitting on the water, including three duck species, three gull species, COLO, and BLGU (Table 23). The 27 COEI consisted of two separate observations of a raft of 15 eiders located in the South quadrat and 12 in the North. All 19 unidentified ducks were also from one raft in the South quadrat, and the

RBME were in groups of four birds in the South quadrat and seven birds together in the North. Two COLO were recorded while actively diving below the water in pursuit of prey and one DCCO was observed sitting on a floating object in the BR. Of the flying birds, 87% were flying direct, with only one BAEA milling 50m high and one GBBG meandering while at 25m high. The majority (53%) of the flying birds were  $\leq 10$ m high. These included three passerine species (one BASW five meters high heading NE, one Tree swallow (*Tachycineta bicolor*, TRES) at 10m heading NE, and one unidentified hummingbird (UNHU) at two meters heading NW); two gulls (HERG and RBGU) at 10m; two DCCO at one meter; and one COLO at five meters heading SE. Species flying over 10m included the milling BAEA at 50m, two OSPR each flying straight at 35m high, the meandering GBBG, and two passerine species (another BASW at 15m high heading E and two unidentified songbirds (SONG) flying 40m high heading NNE). Marine mammal activity in the South quadrat included the two Harbor porpoise that were porpoising and one Harbor seal that was observed eating. The remaining seals were of undetermined behavior.



Map 15. Bird observations on May 7, 2012.

Table 23. Species, behavior code, flight height, and flight direction on May 7<sup>th</sup>.

Behavior code	1	10	20								35	48	70
Height (m)	0	0	1	2	5	10	15	35	40	50	25	(below)	
<b>BAEA*</b>											<b>1</b>		
(blank)											<b>1</b>		
<b>BASW</b>				<b>1</b>		<b>1</b>							
E										1			
NE				1									
<b>BLGU</b>	<b>4</b>												
(blank)	4												
<b>COEI</b>	<b>27</b>												
(blank)	27												
<b>COLO</b>	<b>4</b>				<b>1</b>								<b>2</b>
SE					1								
(blank)	4												2
<b>DCCO</b>		<b>1</b>	<b>2</b>										
NE			1										
NNW			1										
(blank)		1											
<b>GBBG</b>												<b>1</b>	
(blank)												1	
<b>HERG</b>	<b>9</b>					<b>1</b>							
(blank)	9					1							
<b>LAGU</b>	<b>2</b>												
(blank)	2												
<b>OSPR</b>										<b>2</b>			
NE										1			
WSW										1			
<b>RBGU</b>	<b>1</b>					<b>1</b>							
NE						1							
(blank)	1												
<b>RBME</b>	<b>11</b>												
(blank)	11												
<b>SONG</b>										<b>2</b>			
NNE										2			
<b>TRES</b>						<b>1</b>							
NE						1							
<b>UNDU</b>	<b>19</b>												
(blank)	19												
<b>UNHU</b>					<b>1</b>								
NW					1								
<b>Grand Total</b>	<b>77</b>	<b>1</b>	<b>2</b>	<b>1</b>	<b>2</b>	<b>3</b>	<b>1</b>	<b>2</b>	<b>2</b>	<b>1</b>	<b>1</b>	<b>2</b>	

\*Red text indicates Species of Conservation Concern.

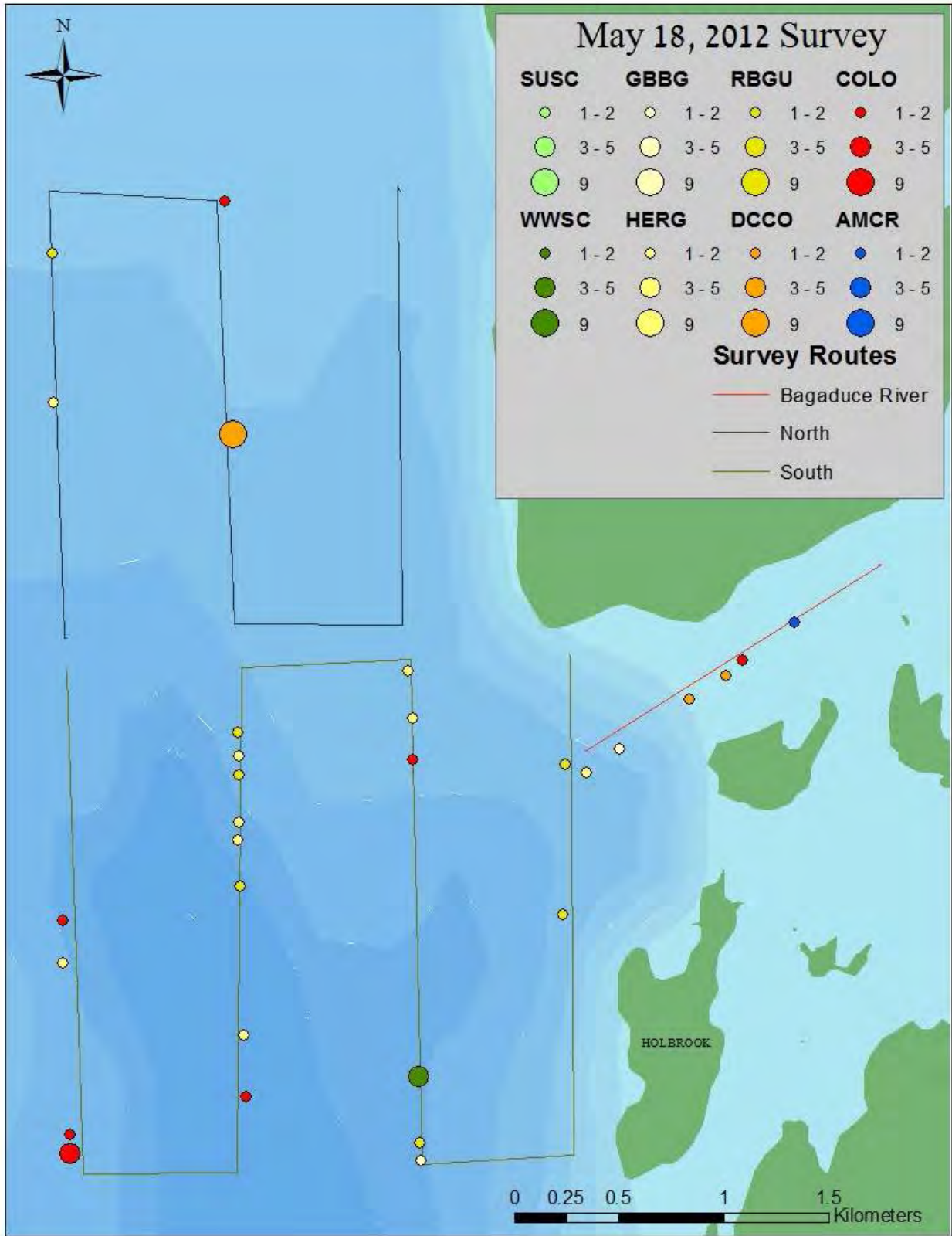
May 18, 2012

MORNING SURVEY (8:27 AM)

Table 24. Numbers of species observed during the morning survey on May 18<sup>th</sup>.

SPECIES	BR	SOUTH	NORTH
American crow	1		
Common loon	1	7	1
Double-crested cormorant	4		9
Great black-backed gull	1	1	
Herring gull	1	9	1
Ring-billed gull		6	1
Surf scoter		5	
White-winged scoter		3	
Harbor porpoise		2	
Harbor seal	1	6	4
<b>TOTAL (3.16 birds/km<sup>2</sup>)</b>	<b>9</b>	<b>39</b>	<b>16</b>

On the morning survey of May 18<sup>th</sup>, conditions were rated as “Maximum” due to clear skies, a slight ripple on the water, and winds averaging five knots from the S and then SW. Map 16 shows the tracklines and wildlife observations. A total of 51 birds (3.16 birds/km<sup>2</sup>) and 13 marine mammals were recorded throughout the survey (Table 24). The majority of birds (60%) were observed in the South quadrat, 24% were in the North, and the remaining 16% were in the BR. The most abundant bird species were the DCCO (25%; 0.81 birds/km<sup>2</sup>), HERG (22%; 0.68 birds/km<sup>2</sup>), COLO (18%; 0.56 birds/km<sup>2</sup>), followed by the RBGU (14%; 0.43 birds/km<sup>2</sup>).



Map 16. Bird observations on May 18, 2012.

Table 25. Species, behavior code, flight height, and flight direction on May 18<sup>th</sup>.

Behavior code	1	10	20							35		48	66
Height (m)	0	0	1	5	10	15	30	40	5	10	10	0	
<b>AMCR</b>										1			
W										1			
<b>COLO</b>	6		1		1		1						
ENE			1										
N					1								
NE							1						
(blank)	6												
<b>DCCO</b>	2	2								9			
N										9			
(blank)	2	2											
<b>GBBG</b>	1		1										
N			1										
(blank)	1												
<b>HERG</b>	4		1		1		1		1		1		
N									1				
NE					1		1						
SE			1										
(blank)	4								1		2		
<b>RBGU</b>	2		1		1				1		1		
ENE					1						1		
N			1										
(blank)	2								1		1		
<b>SUSC</b>			5										
NE			5										
<b>WWSC</b>			3										
NE			3										
<b>Grand Total</b>	15	2	8	3	2	3	1	10	2	1	1	3	

Twenty-nine percent of all birds were observed sitting on the water, which included six COLO, two DCCO, and seven various gulls (Table 25). Two DCCO were sitting on the floating channel marker in the BR, and two HERG and one RBGU were sitting in a current rip and surface seizing food. Of the flying birds, 87% were demonstrating direct flight, three gulls (10%) were milling, and one RBGU was meandering. The majority of these birds (55%) were flying  $\leq 10\text{m}$ , including five SUSC and three WWSC heading directly NE at one meter high; one COLO, HERG, and RBGU were flying direct at five meters; and one GBBG and HERG flew direct at 10m. One HERG and one RBGU milled at five meters and another HERG milled at 10m, while one RBGU meandered flight at 10m. The remaining 45% of birds that flew greater than 10m included one AMCR at 40m high heading W, two COLO at 15m and 30m, one HERG and one RBGU each at 15m, and a single flock of DCCO flying N at 40m high. Marine mammal activity in the South quadrat included the two Harbor porpoise that were porpoising and in the BR one Harbor seal was observed eating. The remaining seals were of undetermined behavior.

**MAY 22, 2012**

**AFTERNOON SURVEY (14:00 PM)**

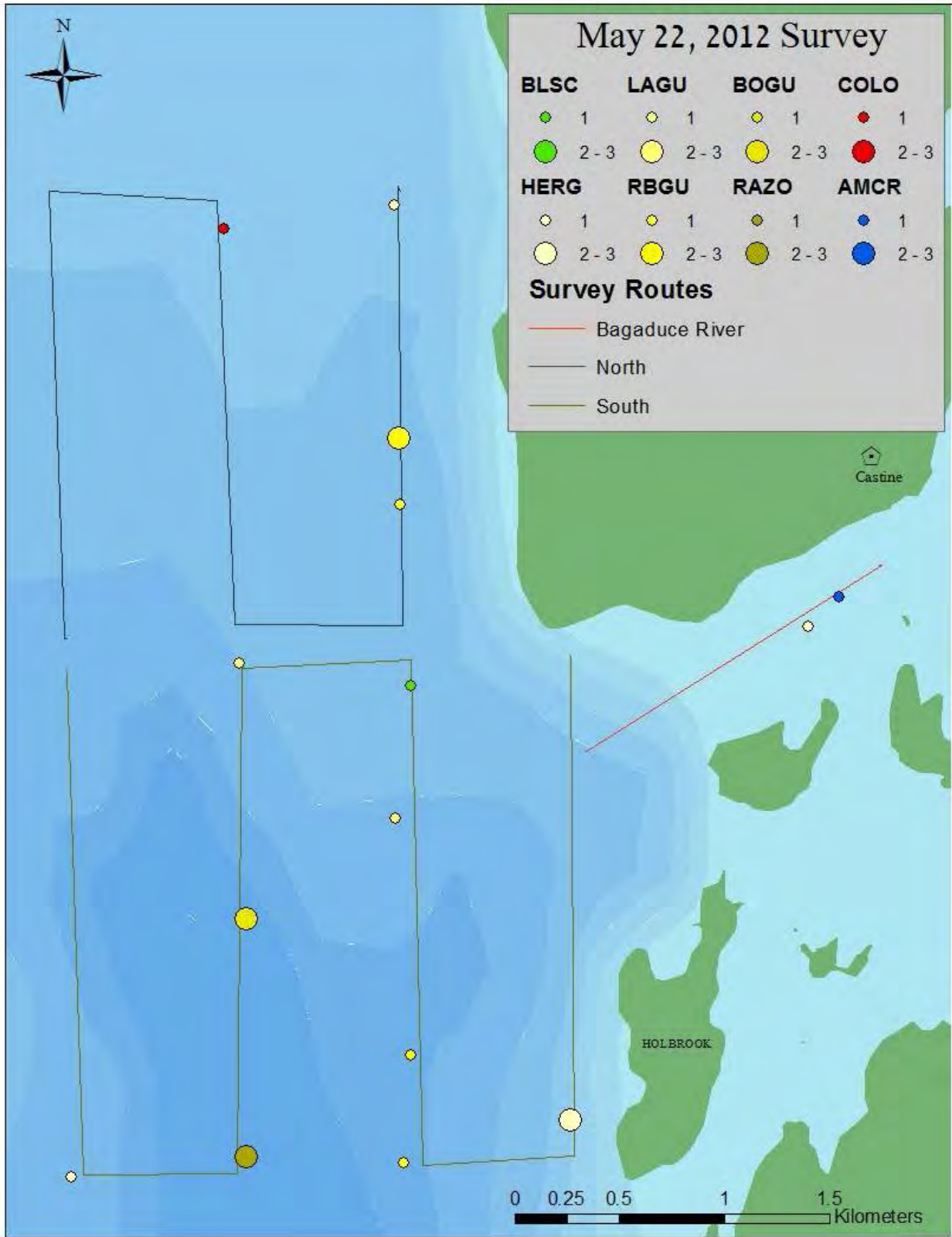
Table 26. Numbers of species observed during the afternoon survey on May 22<sup>nd</sup>.

SPECIES	BR	SOUTH	NORTH
American crow	1		
Black scoter		1	
Bonaparte's gull		3	
Common loon			1
Herring gull	1	3	1
Laughing gull		2	
Razorbill*		2	
Ring-billed gull		2	3
Harbor seal	1	3	1
<b>TOTAL (1.24 birds/km<sup>2</sup>)</b>	<b>3</b>	<b>16</b>	<b>6</b>

\*Red text indicates Species of Conservation Concern.

During the afternoon survey on May 22<sup>nd</sup>, conditions were rated as “Excellent” with overcast skies, five knot winds from the SW changing to eight knots from the S, and seas beginning at a ripple and ending with seas up to two feet. Map 17 shows the tracklines and wildlife observations. The total number of birds equaled only 20 (1.24 birds/km<sup>2</sup>), with five Harbor seals (Table 26). Sixty-five percent of the birds were recorded in the South quadrat, 25% were in the North, and the remaining two bird observations were found in the BR. Gull species made up the majority of the species observed, with five HERG (25%; 0.3 birds/km<sup>2</sup>), five RBGU (25%; 0.3 birds/km<sup>2</sup>), and three Bonaparte's gulls (*Larus philadelphia*, BOGU) (15%; 0.19 birds/km<sup>2</sup>).





Map 17. Bird observations on May 22, 2012.

Table 27. Species, behavior code, flight height, and flight direction on May 22<sup>nd</sup>.

Behavior code	1	20			35		
Height (m)	0	1	5	15	1	5	<5
<b>AMCR</b>					1		
(blank)					1		
<b>BLSC</b>		1					
N		1					
<b>BOGU</b>		3					
SSW		3					
<b>COLO</b>	1						
(blank)	1						
<b>HERG</b>	1		1	2	1		
SSW				2			
SW			1				
(blank)	1				1		
<b>LAGU</b>			1		1		
E			1				
(blank)							1
<b>RAZO*</b>	2						
(blank)	2						
<b>RBGU</b>	3		2				
S			2				
(blank)	3						
<b>Grand Total</b>	7	4	4	2	1	1	1

\*Red text indicates Species of Conservation Concern.

Of all the birds observed, 35% were sitting in the water, and included one HERG, three RBGU, one COLO, and the first (and only) sighting of two Razorbills (*Alca torda*, RAZO) (Table 27). Seventy-seven percent of the flying birds demonstrated direct flight, and the remaining 23% were milling. Two HERG were the only birds to fly above 10m high, heading directly SSW at 15m. The remaining 85% that flew ≤10m included four species of gulls at either one or five meters' height, one AMCR milling at one meter before landing on the shoreline in the BR, and one BLSC flying N at one meter high. One Harbor seal in the South quadrat was observed eating, and all other seals were of undetermined behavior.

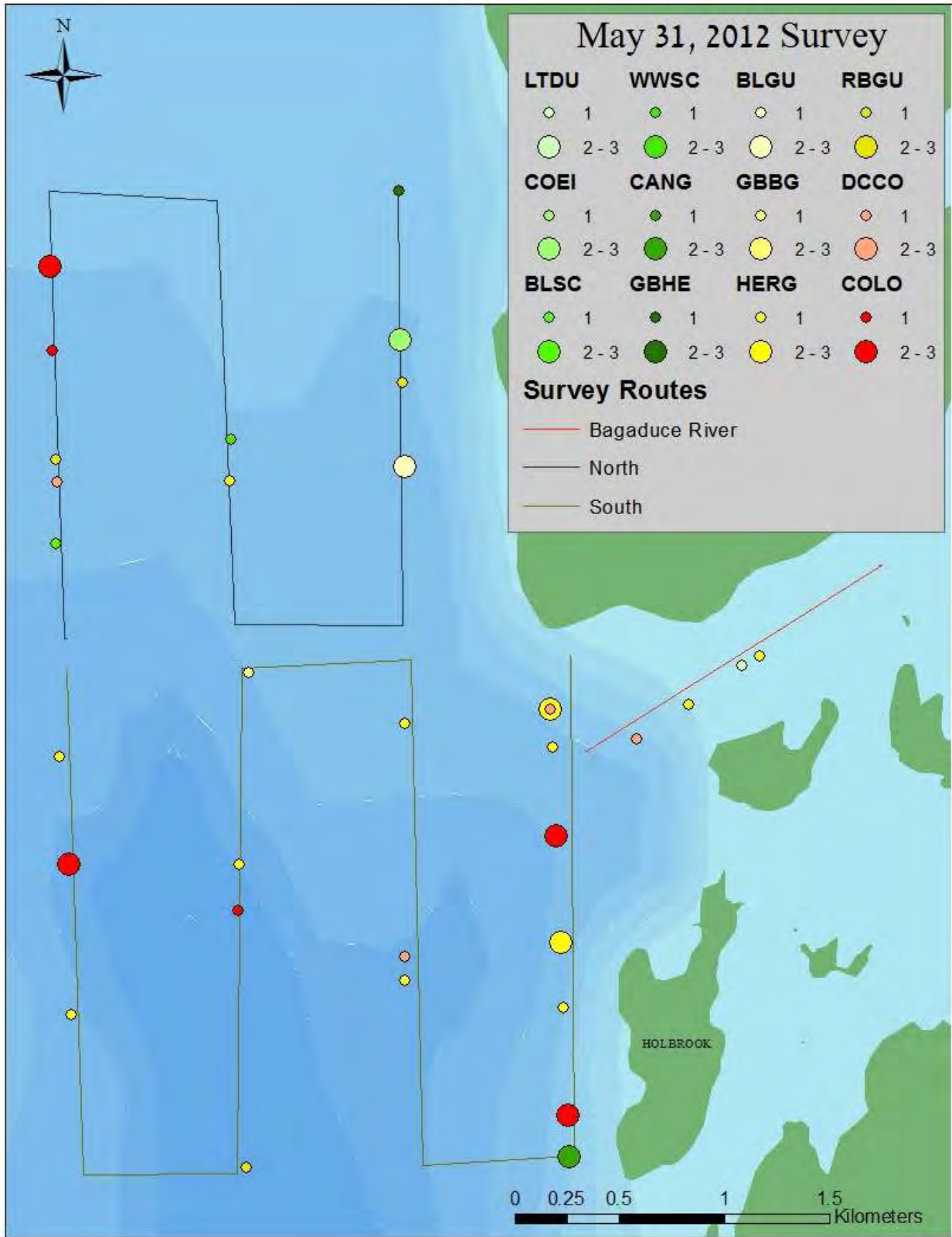
May 31, 2012

MORNING SURVEY (8:26 AM)

Table 28. Numbers of species observed during the morning survey on May 31<sup>th</sup>.

SPECIES	BR	SOUTH	NORTH
Black guillemot	1		2
Black scoter			1
Canada goose		3	
Common eider			3
Common loon		8	3
Double-crested cormorant	1	2	1
Great black-backed gull		1	
Great blue heron			1
Herring gull	2	11	2
Long-tailed duck	1		
Ring-billed gull		2	2
White-winged scoter			1
Harbor porpoise		14	
Harbor seal	1	2	
<b>TOTAL (2.97 birds/km<sup>2</sup>)</b>	<b>6</b>	<b>43</b>	<b>16</b>

On the morning survey of May 31<sup>st</sup>, the conditions were rated as “Maximum” due to flat seas, S winds at three knots, and partly cloudy skies. Map 18 shows the tracklines and wildlife observations. A total of 48 birds (2.97 birds/km<sup>2</sup>) and 17 marine mammals were observed (Table 28). The majority of the birds (56%) were recorded in the South quadrat, 33% in the North, and 10% were in the BR. The most abundant species were HERG (31%; 0.93 birds/km<sup>2</sup>) and COLO (23%; 0.68 birds/km<sup>2</sup>).



Map 18. Bird observations on May 31, 2012.

Table 29. Species, behavior code, flight height, and flight direction on May 31<sup>st</sup>.

Behavior code	1	10	20								48			
Height (m)	0	0	1	2	10	15	20	25	30	35	10	15		
<b>BLGU</b>	1		2											
N (blank)	1		2											
<b>BLSC</b>			1											
NNW			1											
<b>CANG</b>			3											
SSE			3											
<b>COEI</b>	3													
(blank)	3													
<b>COLO</b>	8		2		1									
ENE W (blank)	8				1									
<b>DCCO</b>	1	1	1				1							
ENE WNW (blank)	1	1	1				1							
<b>GBBG</b>					1									
E					1									
<b>GBHE</b>			1											
S			1											
<b>HERG</b>	6		1		3		1		1		1		1 1	
NE NW SSW W WNW (blank)	6						1		1		1		1 1	
<b>LTDU</b>	1													
(blank)	1													
<b>RBGU</b>			1		2		1							
NE SE SSW			1		1		1							
<b>WWSC</b>			1											
N			1											
<b>Grand Total</b>	<b>20</b>	<b>1</b>	<b>6</b>	<b>1</b>	<b>8</b>	<b>6</b>	<b>1</b>	<b>1</b>	<b>1</b>	<b>1</b>	<b>1</b>	<b>1</b>	<b>1</b>	<b>1</b>

Of all bird species recorded, 42% were sitting on the water, which included one LTDU, three COEI, one BLGU, eight COLO, one DCCO, and six HERG (Table 29). One DCCO was observed sitting on the floating channel marker in the BR. The majority of the flying birds (93%) flew direct, with only two HERG meandering, one at 10m and the other at 15m high. Fifty-nine percent of the flying birds flew ≤10m. Two BLGU were flying N, one BLSC was flying NNW, one DCCO flew WNW, one Great blue heron (*Ardea herodias*, GBHE) flew S, and one RBGU flew SE, all at one meter's height. One WWSC flew N at two meters high, and the following flew at 10m: three Canada geese (*Branta canadensis*, CANG) flying SSE, two COLO and one HERG flying W, and two RBGU. The 41% of birds that flew above 10m

included one COLO flying ENE at 15m, one DCCO flying ENE at 25m. Three species of gulls, totaling 8 birds, flew from 15m to 35m high. All 14 of the Harbor porpoise were observed in the South quadrat, as well as two of the three Harbor seals. Only one Harbor seal was observed in the BR strip.

**June 5, 2012**

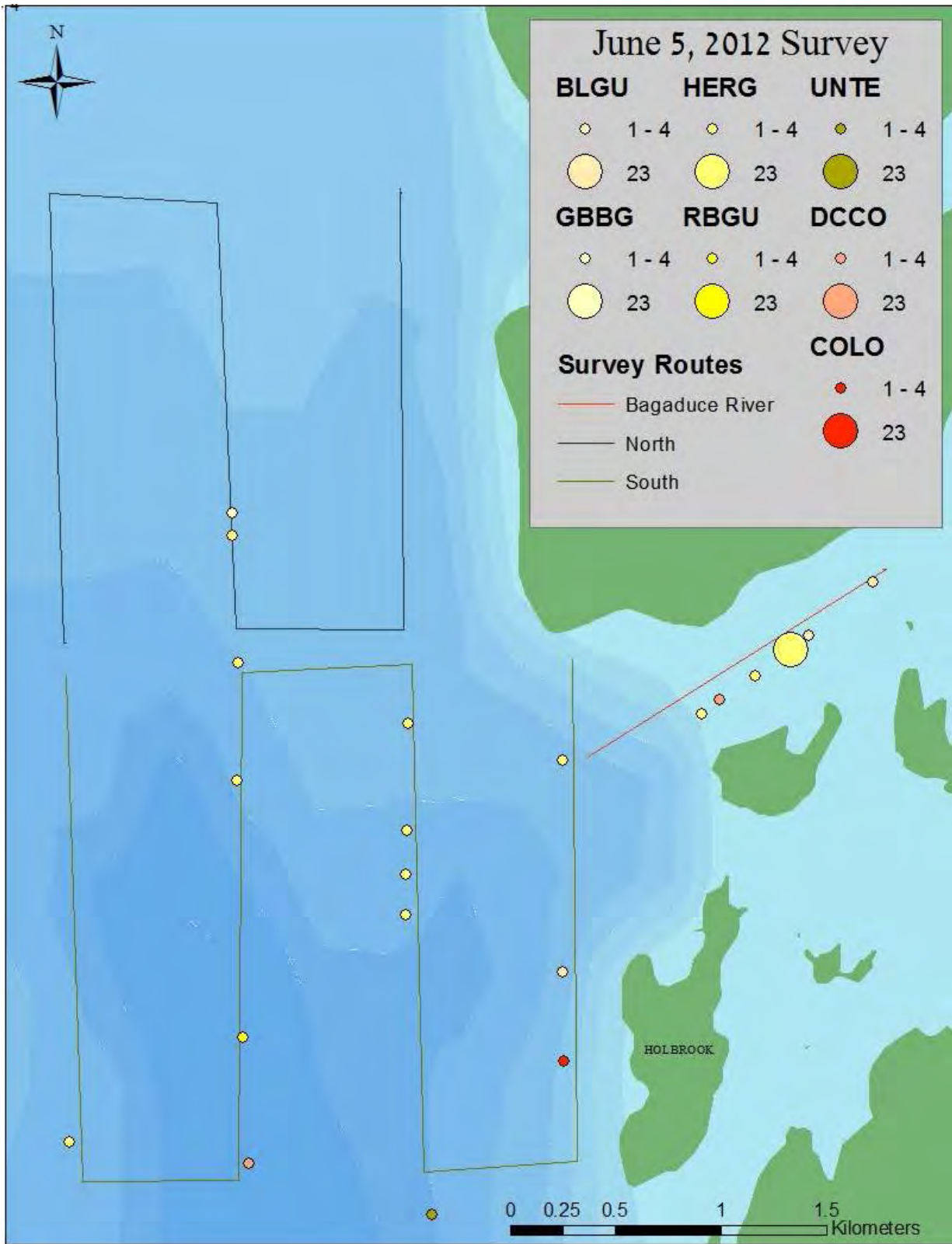
**MORNING SURVEY (8:32 AM)**

Table 30. Numbers of species observed during the morning survey on June 5<sup>th</sup>.

SPECIES	BR	SOUTH	NORTH
Black guillemot	3	1	
Common loon		1	
Double-crested cormorant	1	1	
Great black-backed gull			1
Herring gull	26	12	2
Ring-billed gull		1	
Unidentified tern*		1	
Harbor porpoise	2		
Harbor seal		2	
<b>TOTAL (3.1 birds/km<sup>2</sup>)</b>	<b>32</b>	<b>19</b>	<b>3</b>

\*Red text indicates potential Species of Conservation Concern.

On the morning survey of June 5<sup>th</sup>, conditions were rated as “Maximum” with partly cloudy skies, N winds around eight knots increasing to 12kts, and seas between one and four feet. Map 19 shows the tracklines and wildlife observations. There were 50 total birds (3.1 birds/km<sup>2</sup>) and four marine mammals observed throughout the day (Table 30). The majority of birds (60%) were observed in the BR, 34% in the South quadrat, and 6% in the North. Herring gulls were by far the most abundant species, representing 80% of all birds recorded (2.48 birds/km<sup>2</sup>).



Map 19. Bird observations on June 5, 2012.

Table 31. Species, behavior code, flight height, and flight direction on June 5<sup>th</sup>.

Behavior code	1	10	20					29	32	35		48
Height (m)	0	0	1	5	10	15	20	<5	5	35	50	3
<b>BLGU</b>	<b>4</b>											
No direction	4											
<b>COLO</b>	<b>1</b>											
No direction	1											
<b>DCCO</b>			<b>1</b>		<b>1</b>							
N			1									
SW					1							
<b>GBBG</b>			<b>1</b>									
SW			1									
<b>HERG</b>	<b>30</b>					<b>3</b>	<b>1</b>		<b>3</b>	<b>1</b>	<b>1</b>	<b>1</b>
E												1
S							1					
SE							1					
SSE							1					
SSW								1				
No direction	30								3	1	1	
<b>RBGU</b>								<b>1</b>				
E								1				
<b>UNTE*</b>		<b>1</b>										
No direction		1										
<b>Grand Total</b>	<b>35</b>	<b>1</b>	<b>1</b>	<b>1</b>	<b>1</b>	<b>3</b>	<b>1</b>	<b>1</b>	<b>3</b>	<b>1</b>	<b>1</b>	<b>1</b>

\*Red text indicates potential Species of Conservation Concern.

Four BLGU, one COLO, and 30 HERG were observed sitting on the water, making up 70% of the total birds observed throughout the day. One unidentified tern (UNTE) species was observed sitting on a floating object in the South quadrat (Table 31). Half of the flying birds were demonstrating direct flight, with one RBGU flying variable heights under five meters, three HERG (21%) flew five meters high while following a boat, two HERG (14%) milled, and one HERG meandered at three meters high. Of the flying birds, 57% flew ≤10m. These included two DCCO, one at one meter and the other at 10m high, and three gull species. Four HERG flew from 15m to 50m high, in both direct and milling flight. The two Harbor porpoise were porpoising in the BR, while the two Harbor seals were observed in the South quadrat with undetermined behavior.



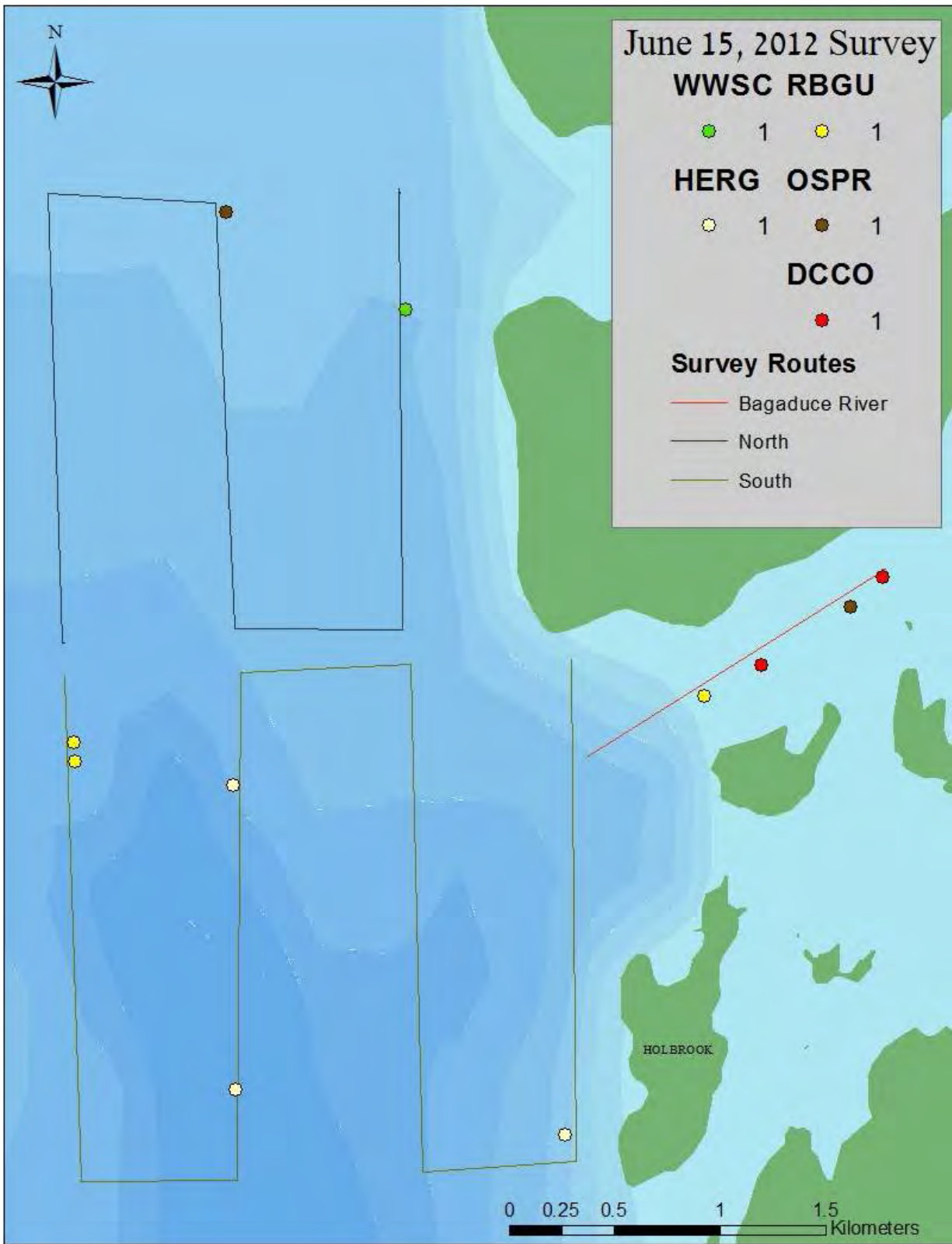
**JUNE 15, 2012**

**AFTERNOON SURVEY (12:22 PM)**

Table 32. Numbers of species observed during the afternoon survey on June 15<sup>th</sup>.

SPECIES	BR	SOUTH	NORTH
Double-crested cormorant	2		
Herring gull		4	
Osprey	1		1
Ring-billed gull	1	2	
White-winged scoter			1
Harbor seal	1	1	
<b>TOTAL (0.74 birds/km<sup>2</sup>)</b>	<b>5</b>	<b>7</b>	<b>2</b>

On the afternoon of June 15<sup>th</sup>, conditions were rated as “Maximum” due to sunny skies, N winds around eight knots, and seas no more than two feet. Map 20 shows the tracklines and wildlife observations. A total of 12 birds (0.74 birds/km<sup>2</sup>) and two Harbor seals were observed throughout the day (Table 32). Half of the birds were observed in the South quadrat, 33% in the BR, and 17% in the North. Herring gulls were the most abundant species, with four birds making up 33% of all birds recorded (0.25 birds/km<sup>2</sup>).



Map 20. Bird observations on June 15, 2012.

Table 33. Species, behavior code, flight height, and flight direction on June 15<sup>th</sup>.

Behavior code	1	20	48	61	70
Height (m)	0	1	5	5	2 (below)
<b>DCCO</b>		1			1
S		1			
No direction					1
<b>HERG</b>	2	1		1	
N		1			
No direction	2			1	
<b>OSPR</b>		1		1	
SSE		1			
No direction				1	
<b>RBGU</b>	1	1	1		
ENE			1		
No direction	1	1			
<b>WWSC</b>	1				
No direction	1				
<b>Grand Total</b>	<b>4</b>	<b>1</b>	<b>3</b>	<b>1</b>	<b>2</b>

Two HERG, one RBGU, and one WWSC were sitting on the water, making up 33% of all birds observed. One DCCO was observed actively diving under the water from a sitting position in pursuit of prey (Table 33). Of the flying birds, 33% were displaying directional flight, one RBGU meandered, and two birds (17%) were observed dipping food from the water while flying. One of these birds included an OSPR catching a fish from an initial observed height of two meters. All flying birds (100%) were recorded as below 10m high. One Harbor seal was hauled out on a small rock in the middle of the BR, and the other seal was found in the South quadrat, with undetermined behavior.

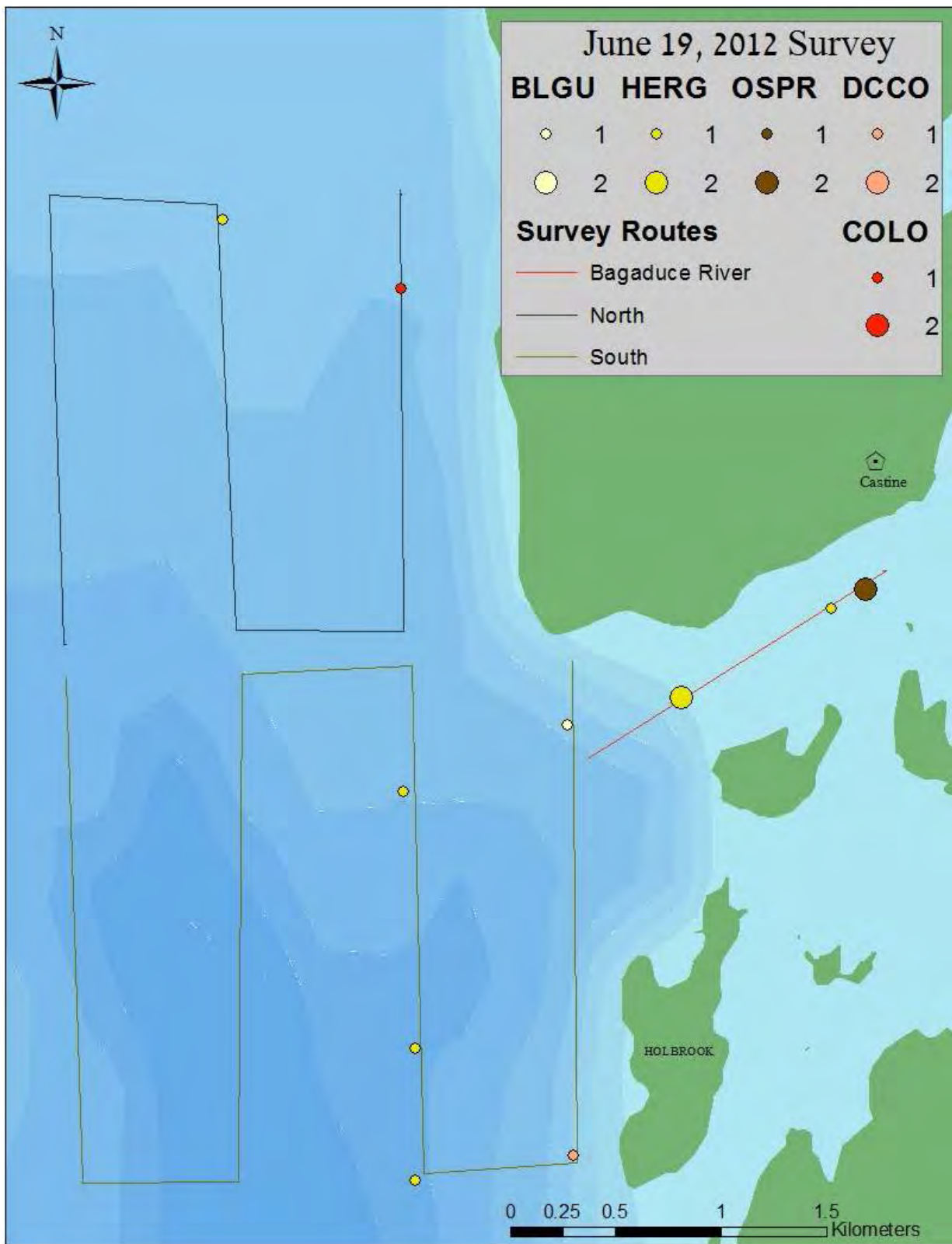
**JUNE 19, 2012**

**AFTERNOON SURVEY (13:24 PM)**

Table 34. Numbers of species observed during the afternoon survey on June 19<sup>th</sup>.

<b>SPECIES</b>	<b>BR</b>	<b>SOUTH</b>	<b>NORTH</b>
Black guillemot		1	
Common loon			1
Double-crested cormorant	1	1	
Herring gull	3	3	1
Osprey	2		
Harbor seal		1	
<b>TOTAL (0.81 birds/km<sup>2</sup>)</b>	<b>6</b>	<b>6</b>	<b>2</b>

During the afternoon survey on June 19<sup>th</sup>, conditions were rated as “Average” to “Good” because of higher seas from two to six feet, sunny skies with medium to high glare, and S winds around five knots. Map 21 shows the tracklines and wildlife observations. Thirteen total birds (0.81 birds/km<sup>2</sup>) and only one Harbor seal were observed (Table 34). Forty-six percent of all bird observations were in the BR, 38% in the South, and 15% were in the North quadrant. Herring gulls were the most abundant species, comprising 54% of all birds recorded (0.43 birds/km<sup>2</sup>).



Map 21. Bird observations on June 19, 2012.

Table 35. Species, behavior code, flight height, and flight direction on June 19<sup>th</sup>.

Behavior code	1	15	20	29	32	48	
Height (m)	0	(nested)	1	15	<5	10	5
<b>BLGU</b>			1				
NE			1				
<b>COLO</b>	1						
(blank)	1						
<b>DCCO</b>	1		1				
SE			1				
(blank)	1						
<b>HERG</b>			1	2	1	1	2
E					1		1
N				2			
S						1	
SE							1
WSW			1				
<b>OSPR</b>		2					
(blank)		2					
<b>Grand Total</b>	<b>2</b>	<b>2</b>	<b>3</b>	<b>2</b>	<b>1</b>	<b>1</b>	<b>2</b>

Two birds (one COLO, one DCCO) were sitting on the water, comprising 15% of all birds observed, and two OSPR were sitting in a nest located in a stone channel marker in the BR (Table 35). Of the flying birds, 56% were displaying directional flight, one HERG flew variable heights under five meters, one HERG was following a boat at 10m before landing on the water, and two HERG (22%) were meandering at five meters high. The majority of the flying birds (78%) flew  $\leq 10$ m, which included one BLGU at one meter flying NE, one DCCO flying SE, and five HERG flying from one to 10m. Only two HERG were observed above 10m, flying straight N at 15m high. The single Harbor seal was recorded in the South quadrat, with undetermined behavior.

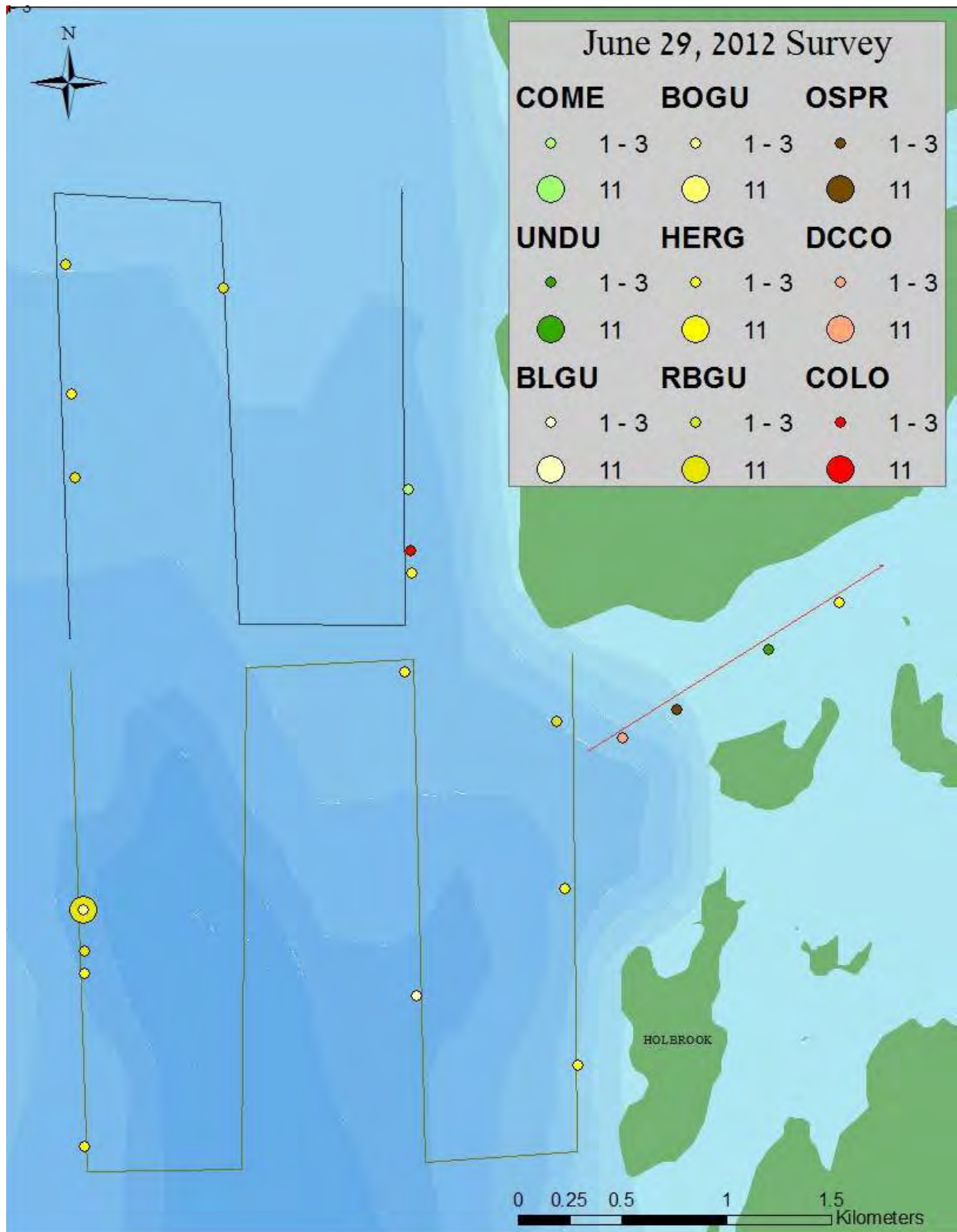
June 29, 2012

MORNING SURVEY (8:39 AM)

Table 36. Numbers of species observed during the morning survey on June 29<sup>th</sup>.

SPECIES	BR	SOUTH	NORTH
Black guillemot		1	
Bonaparte's gull		1	
Common loon			3
Common merganser			1
Double-crested cormorant	3		
Herring gull	2	5	2
Osprey	1		
Ring-billed gull		13	4
Unidentified duck	1		
Gray seal			1
Harbor porpoise	2	4	3
Harbor seal	1	6	
<b>TOTAL (2.35 birds/km<sup>2</sup>)</b>	<b>10</b>	<b>30</b>	<b>14</b>

On the final morning of June 29<sup>th</sup>, conditions were rated as “Maximum” due to flat to a slight ripple on the seas, partly cloudy skies, and SE winds from three to seven knots. Map 22 shows the tracklines and wildlife observations. There were a total of 38 birds (2.35 birds/km<sup>2</sup>) and 16 total marine mammals observed (Table 36). The majority of the birds (53%) were recorded in the South quadrat, as well as 63% of all marine mammals. The BR quadrats had 21% of the recorded birds, and the North quadrat contained 29%. Both the BR and North quadrat included three marine mammals (19%). The most abundant species were the RBGU with 17 birds (81%; 1.05 birds/km<sup>2</sup>), followed by nine HERG (43%; 0.56 birds/km<sup>2</sup>), and nine Harbor porpoise (56% of marine mammal total; 0.56 marine mammals/km<sup>2</sup>).



Map 22. Bird observations on June 29, 2012.



Table 37. Species, behavior code, flight height, and flight direction on June 29<sup>th</sup>.

Behavior code	1	20								35				61	66	70	
Height (m)	0	1	5	10	15	20	25	30	35	3	<5	15	35	<5	0	0	
<b>BLGU</b>		1															
SSW		1															
<b>BOGU</b>														1			
(blank)														1			
<b>COLO</b>			3														
SE			3														
<b>COME</b>										1							
(blank)										1							
<b>DCCO</b>	1	2															
SE		1															
W		1															
(blank)	1																
<b>HERG</b>	1			1	1	2	1	1			1	1					
ESE			1														
N							1										
NE												1					
NNW								1									
S												1					
W						1											
(blank)	1											1	1				
<b>OSPR</b>		1															
NNE		1															
<b>RBGU</b>	1	2								1	1			1	11		
NE		1															
SE		1															
(blank)	1									1	1			1	11		
<b>UNDU</b>																1	
(blank)																1	
<b>Grand Total</b>	<b>3</b>	<b>3</b>	<b>2</b>	<b>4</b>	<b>1</b>	<b>1</b>	<b>2</b>	<b>1</b>	<b>1</b>	<b>1</b>	<b>2</b>	<b>1</b>	<b>1</b>	<b>2</b>	<b>11</b>	<b>1</b>	

Only three birds (eight percent) were observed sitting on the water, and they included one DCCO, one HERG, and one RBGU (Table 37). Eleven RBGU (29%) sat on the water while foraging in a current rip, and one unidentified duck (UNDU) was observed actively diving under the water from a sitting position, in pursuit of prey. The remaining 61% of the bird observations were flying, with 68% of the flying birds demonstrating direct flight, 23% milling as if to forage, and two birds (9%) were foraging off the surface while flying. Of the birds in flight, 64% were ≤10m high. These included one BLGU and two DCCO flying one meter high, one foraging BOGU and one RBGU under five meters and one Common merganser (*Mergus merganser*, COME) and another RBGU milling below five meters, two RBGU flying direct at five meters, and three COLO flying SE and one OSPR flying NNE both at 10m high. The remaining 36% of flying birds above 10m were all HERG, flying direct or milling from 15m to 35m high. The one and only Gray seal (*Halichoerus gypus*) observed throughout the survey season occurred on this date, and it was recorded in the North quadrat with undetermined behavior. All Harbor porpoise were porpoising, and the Harbor seals also had undetermined behavior.

## BEHAVIOR CATEGORIES

### Non-bird Species Summary

A complete list of all species observed is provided in Appendices 2 and 3, summarizing the species and the dates on which they were documented. Neither turtles nor tuna were observed throughout the season. Fourteen days produced Harbor seals, and on seven days Harbor porpoise were observed (Figure 1). Table 38 summarizes the tuna, harbor porpoise, and harbor seal numbers by date observed in the BR, South, and North survey quadrats. The single Gray seal and all but four seals (three feeding and one hauled out on a rock) were recorded as “Undetermined behavior.” They may have been sleeping, observing our vessel’s activity, or any other behavior that caused their head to be above the surface when they were recorded. Regarding all 66 Harbor seals, 58% were found in the South quadrat (0.29 Hseals/km<sup>2</sup>), 29% in the North (0.18 Hseals/km<sup>2</sup>), and 14% in the BR (0.35 Hseals/km<sup>2</sup>) (Map 23). The 34 Harbor porpoise were also observed in all three quadrats, with the vast majority (79%; 0.21 HAPO/km<sup>2</sup>) found in the South quadrat, 12% in the BR (0.16 HAPO/km<sup>2</sup>), and nine percent in the North quadrat (0.03 HAPO/km<sup>2</sup>). This data shows that 64% of all marine mammal activity and presence occurred in the South quadrat (0.49 mar.mamm./km<sup>2</sup>), but 0.50 mar.mamm./km<sup>2</sup> were in the BR and only 0.21 mar.mamm./km<sup>2</sup> were in the North.

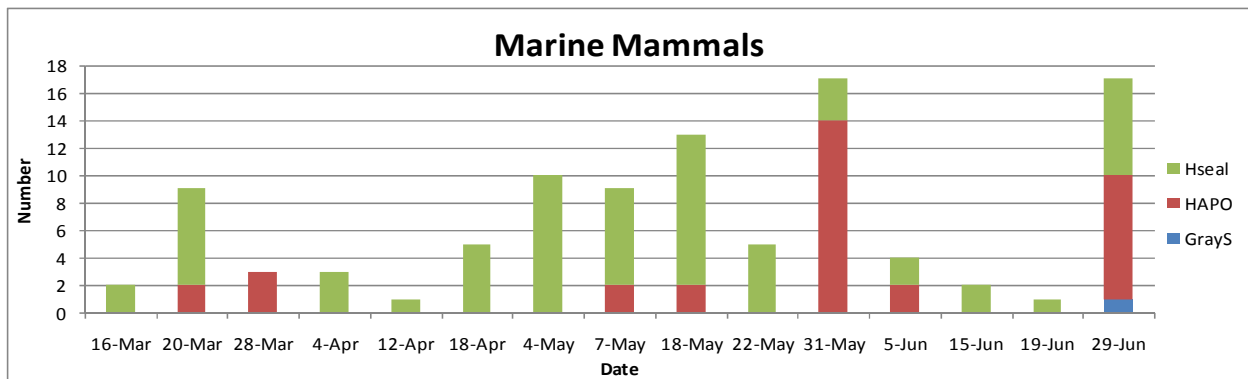
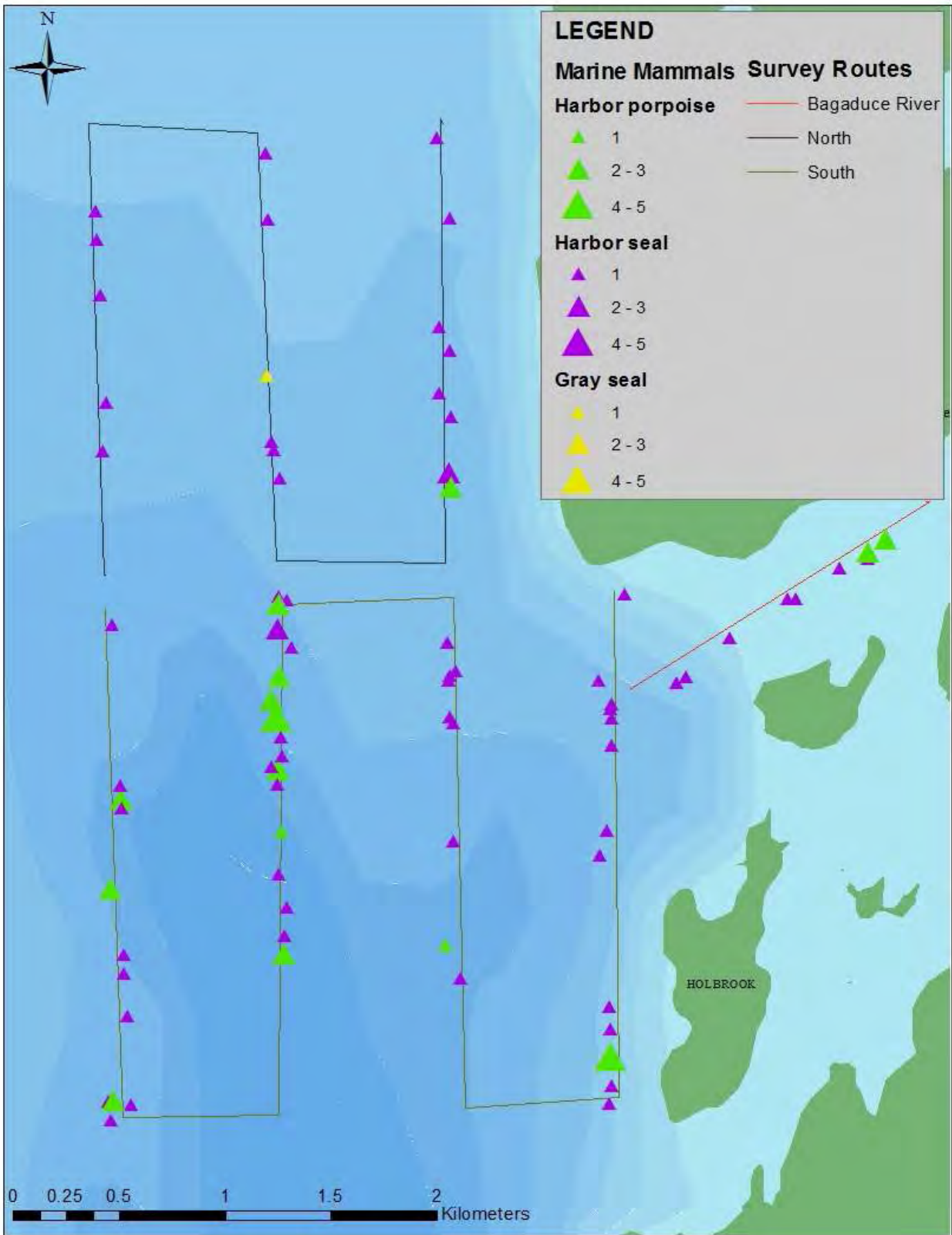


Figure 1. Numbers of Marine Mammal species (Harbor seal, Harbor porpoise, and Gray seals) observed by date.

Table 38. Marine mammals observed by date and transect location.

Date, Transect, and Species	16-Mar	20-Mar	28-Mar	4-Apr	12-Apr	18-Apr	4-May	7-May	18-May	22-May	31-May	5-Jun	15-Jun	19-Jun	29-Jun	TOTAL
<b>BR</b>																
HAPO												2			2	4
Hseal				1			1	2	1	1	1		1		1	9
<b>South</b>																
HAPO		2	3					2	2		14				4	27
Hseal		3		1	1	2	6	4	6	3	2	2	1	1	6	38
<b>North</b>																
GrayS															1	1
HAPO															3	3
Hseal	2	4		1		3	3	1	4	1						19
<b>Grand Total</b>	<b>2</b>	<b>9</b>	<b>3</b>	<b>3</b>	<b>1</b>	<b>5</b>	<b>10</b>	<b>9</b>	<b>13</b>	<b>5</b>	<b>17</b>	<b>4</b>	<b>2</b>	<b>1</b>	<b>17</b>	<b>101</b>



Map 23. Marine mammals observed throughout the season.

### Bird Species Behavior Summaries

To further discuss the bird observations during these surveys, bird species will be grouped by a taxonomical classification at the Order level. Nine orders within the Class Aves comprise the seabirds, waterfowl, and other species that commonly utilize this upper Penobscot Bay region and they are as follows:

<b>-Order Anseriformes</b>	(ducks, geese, eider, scoters)
<b>-Order Pelecaniformes</b>	(herons)
<b>-Order Podicipediformes</b>	(grebes)
<b>-Order Charadriiformes</b>	(large and small gulls, razorbills, puffins)
<b>-Order Accipiteriformes</b>	(eagles, osprey, New World vultures)
<b>-Order Falconiformes</b>	(falcons)
<b>-Order Gaviiformes</b>	(loons)
<b>-Order Suliformes</b>	(cormorants)
<b>-Order Passeriformes</b>	(songbirds)

Flight height and behavior were recorded in the three quadrats, and the following figures will show flight height within the three most common flight behavior categories (direct flight, milling, and meandering). To simplify species' comparisons in the following discussion, particularly due to a single species representing the Orders Pelecaniformes, Falconiformes, Podicipediformes, and Suliformes, the observed species will be grouped into only five categories, based on similar behavioral characteristics. The groups are as follows: 1) Anseriformes, Pelecaniformes, & Podicipediformes; 2) Charadriiformes; 3) Accipiteriformes & Falconiformes; 4) Suliformes & Gaviiformes; and 5) Passeriformes.

The maps in the previous section that display each survey's bird observations have been colored using a consistent scheme that groups each of these five Orders into color groups. Group 1 is represented by shades of green, Group 2 have yellows, Group 3 have browns, Group 4 have reds and Group 5 have blues. This color scheme will be used in the foraging species and birds of conservation concern discussion, below. It does not include marine mammals or other maps.

Further discussion regarding the other observed behaviors of the bird species will follow.

## DIRECT FLIGHT (Behavioral code #20)

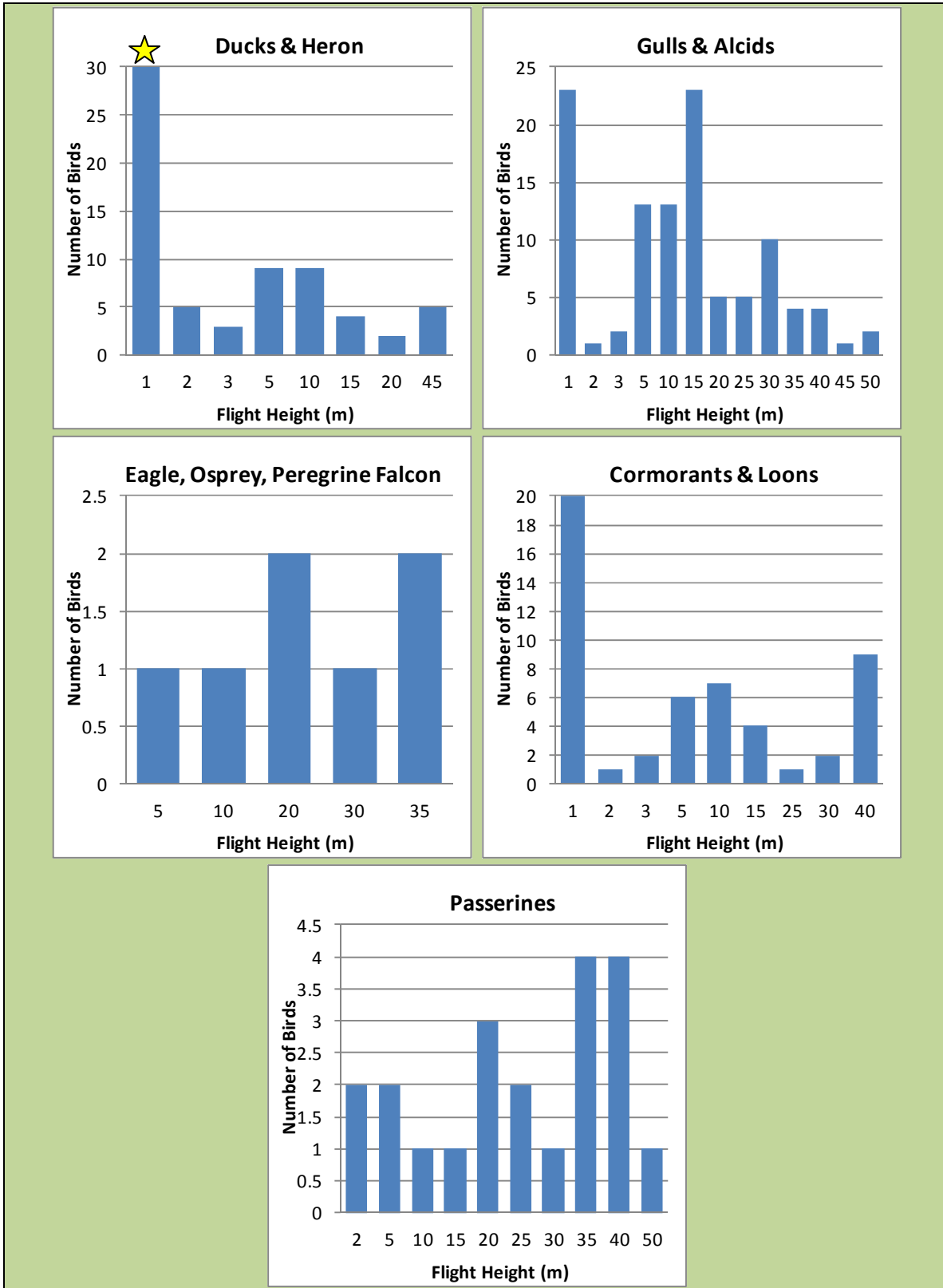


Figure 2. Flight heights of birds by group demonstrating direct flight. The yellow star represents 138 birds flying at one meter high.

Figure 2 shows the behavioral data with species grouped by the above-mentioned Order groups, displaying only behavior determined to be direct flight. Direct flight is described as a bird flying consistently through the area, not actively involved in foraging or other activities. The designation of this behavior during the survey is taken at the precise moment it is noticed by the surveyor. Of all bird behaviors, direct flight was observed in 36% of all bird species, and was the second most common activity type.

When in direct flight, the vast majority of Group 1: Anseriformes (79%) flew one meter above the surface (represented by the yellow star on Group 1: “Ducks & Heron” chart in Figure 2). Even though 119 of these birds (86% of birds at one meter) were common eider, a large portion of the other duck species (11%) also flew one meter high, consisting mostly of scoters and a few other ducks. Eleven percent of the Anseriformes flew between five and 10m, and only eiders (5%) flew at the 20m and 45m heights.

Twenty-two percent of the Group 2: Charadriiformes, consisting of gulls and one alcid species (Black guillemot), flew one meter high, with all guillemots only flying either at one meter or three meters above the water. Most gulls flew from five to 15m high (46%) and 9% flew at 30m.

Only seven total birds in Group 3: Accipiteriformes & Falconiformes flew direct, consisting of two Bald eagles flying at 20m, one Peregrine falcon at 30m, and one Osprey at both one and five meters, and two Osprey flying at 35m.

In Group 4: Gaviiformes & Suliformes, 52 birds demonstrated direct flight, with the majority being Double-crested cormorants (44%) and Common loons (40%). At least one Red-throated loon was observed flying at every height from one meter up to 30m, but 90% of the Common loons flew from one meter up to 15m high. Cormorants mostly flew at one meter high (48%) or at 40m (39%).

Of the 21 birds that were in Group 5: Passeriformes, 57% were American crows. The single unidentified hummingbird flew at two meters high and the Barn and Tree swallows flew from two meters to 15m high. The identified pair of Snow buntings flew at 20m and the unidentified pair of songbirds flew at 40m. One crow flew five meters above the water but the remaining 92% of crows flew from 20m to 50m, with 33% of the crows flying at 35m.

### ***Direct Flight Behavior Summary:***

Exactly 50% of all the birds demonstrating directional flight behavior flew within one meter of the water’s surface. The next most frequented height ranges of direct flight exhibited by all the groups was between five and 15m (26%) (Figure 3). Figure 4 also shows the more common direction birds were observed flying, with 27% flying due north and 14% flying NW, followed by 12% flying NE, and eight percent flying due east.

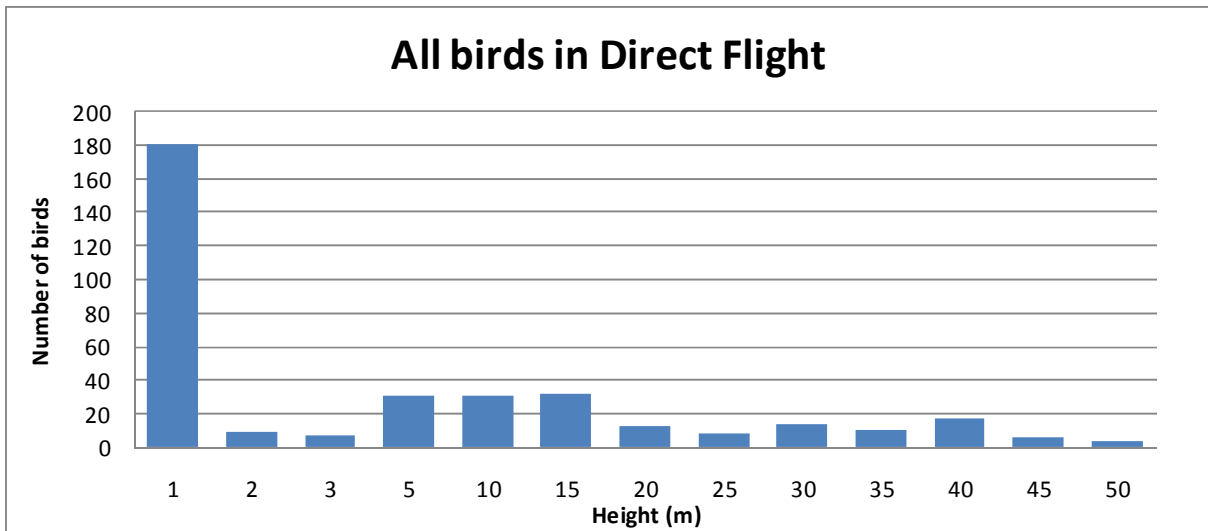


Figure 3. Height of all birds flying with Directional Flight.

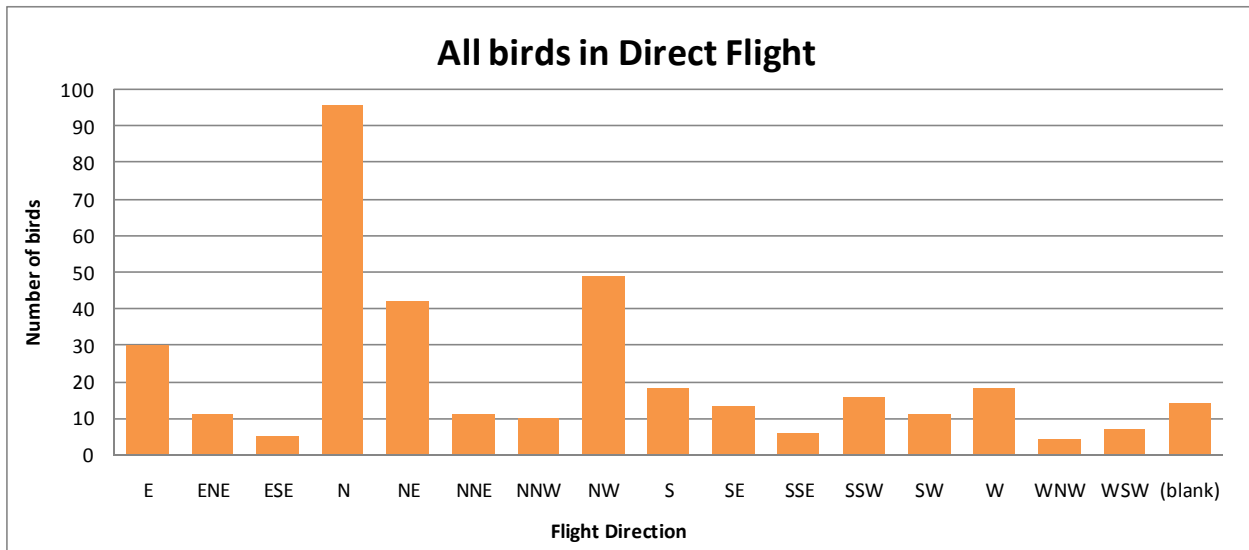


Figure 4. Flight direction of all birds demonstrating Directional Flight.

## MILLING BEHAVIOR (Behavioral code #35)

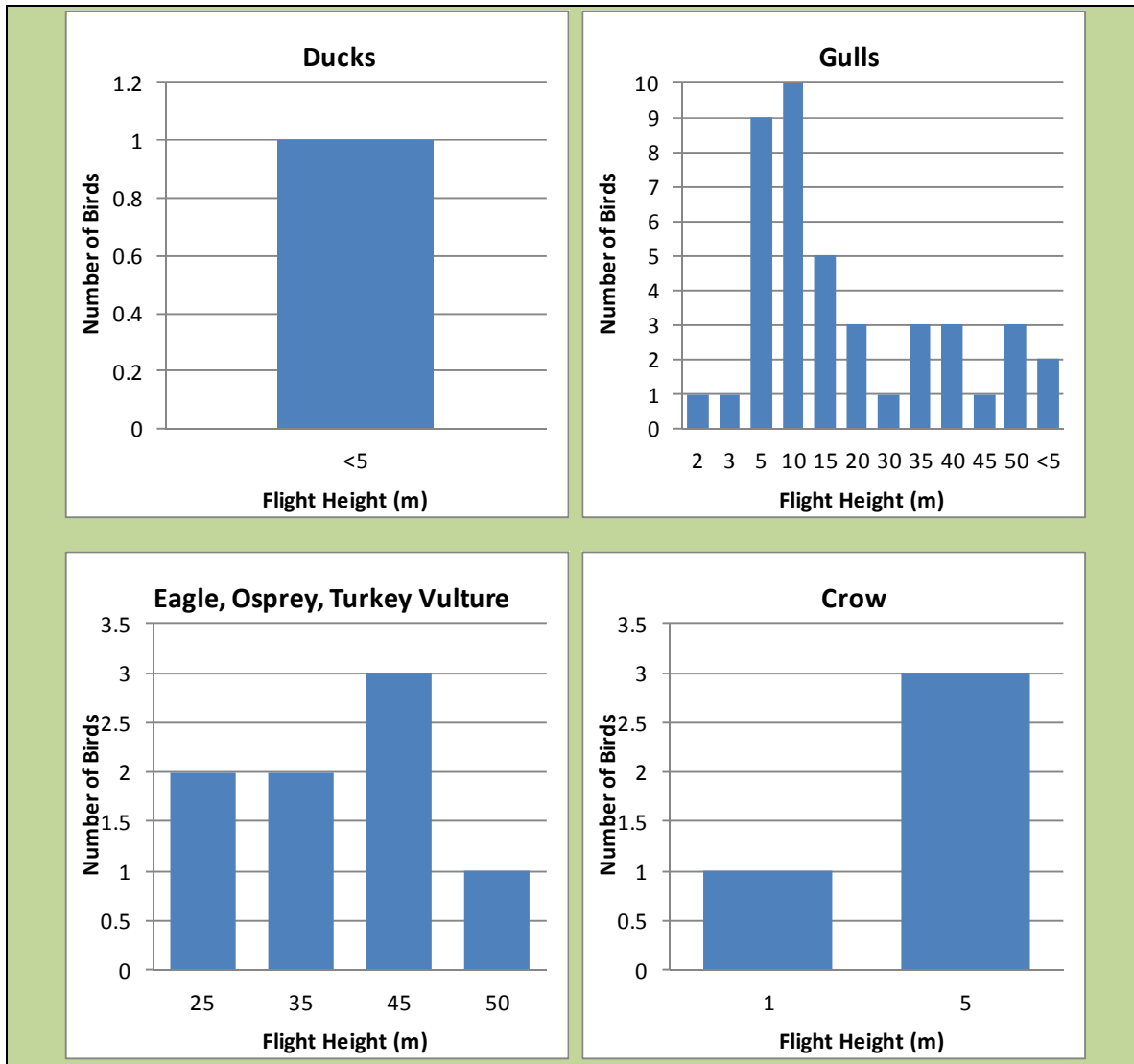


Figure 5. Flight heights of birds by group, demonstrating milling flight. No birds in Group 4: Gaviiformes & Suliformes exhibited this behavior type.

Figure 5 shows milling behavior data with species grouped by Order. Milling flight is described as a bird flying in a more distinct circling or milling path that is usually associated with foraging search patterns, as mentioned above for meandering behavior. Similar to meandering flight, general direction of milling flight constantly changes, thus flight direction is rarely noted in the survey data for these birds. Of all bird behavior types, milling flight constituted 5.5% of all bird species observed, making it the third most common behavior.

In Group 1: Anseriformes, only one individual Common merganser was recorded as milling at a height under five meters. The majority of the gull species in Group 2:



Charadriiformes (57%) milled at heights from five to 15m, with equal numbers (7% each) flying at the 20, 35, 40, and 50m heights.

In Group 3, there were only eight birds milling which consisted of two Osprey at 25m, five Turkey vultures milling at 35 and 45m, and one Bald eagle milling at 50m.

No birds representing Group 4 (cormorants & loons) demonstrated milling behavior and all the birds in Group 5: Passeriformes consisted entirely of crows. One of the four total crows demonstrating milling behavior flew at one meter, with the remaining milling at five meters high.

**Milling Flight Behavior Summary:**

Almost half of all the birds with milling flight behavior flew under 15m; 22% were at five meters, 18% were at 10m, and 9% were at 15m. Twenty-nine percent of all birds milled at heights from 35 to 50m. Because this is a behavior type associated with potential foraging, it is common that no flight direction is associated with the birds' observations. Particularly with the Charadriiformes species, the majority of the birds milling at the heights from three to 20m is a reasonable height for these visual-based foragers to be flying while surveying their surroundings for potential prey. Figure 6 shows the species, numbers, and flight height for all observed milling birds.

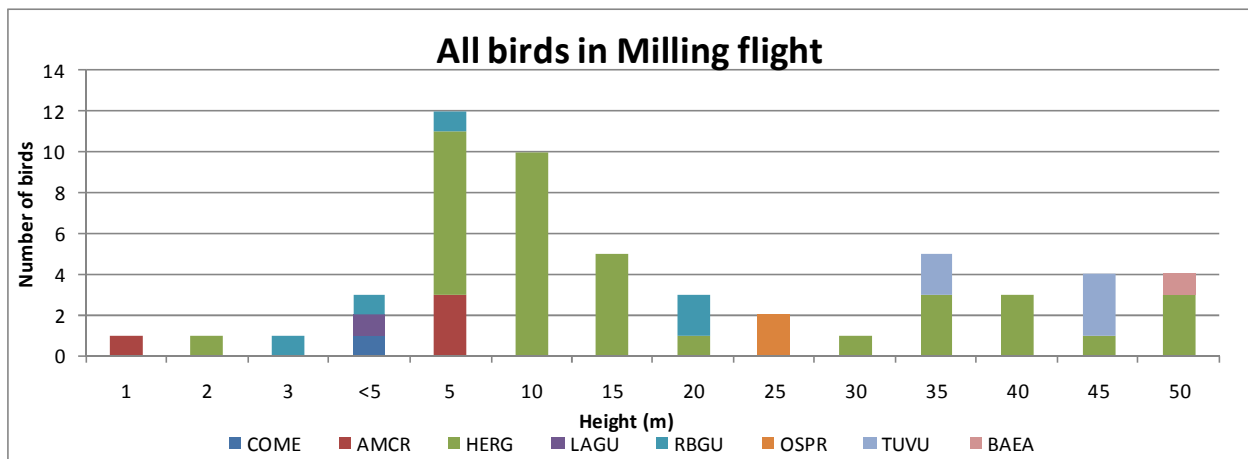


Figure 6. Flight heights and numbers of each species demonstrating Milling flight behavior.

## MEANDERING BEHAVIOR (Behavioral code #48)

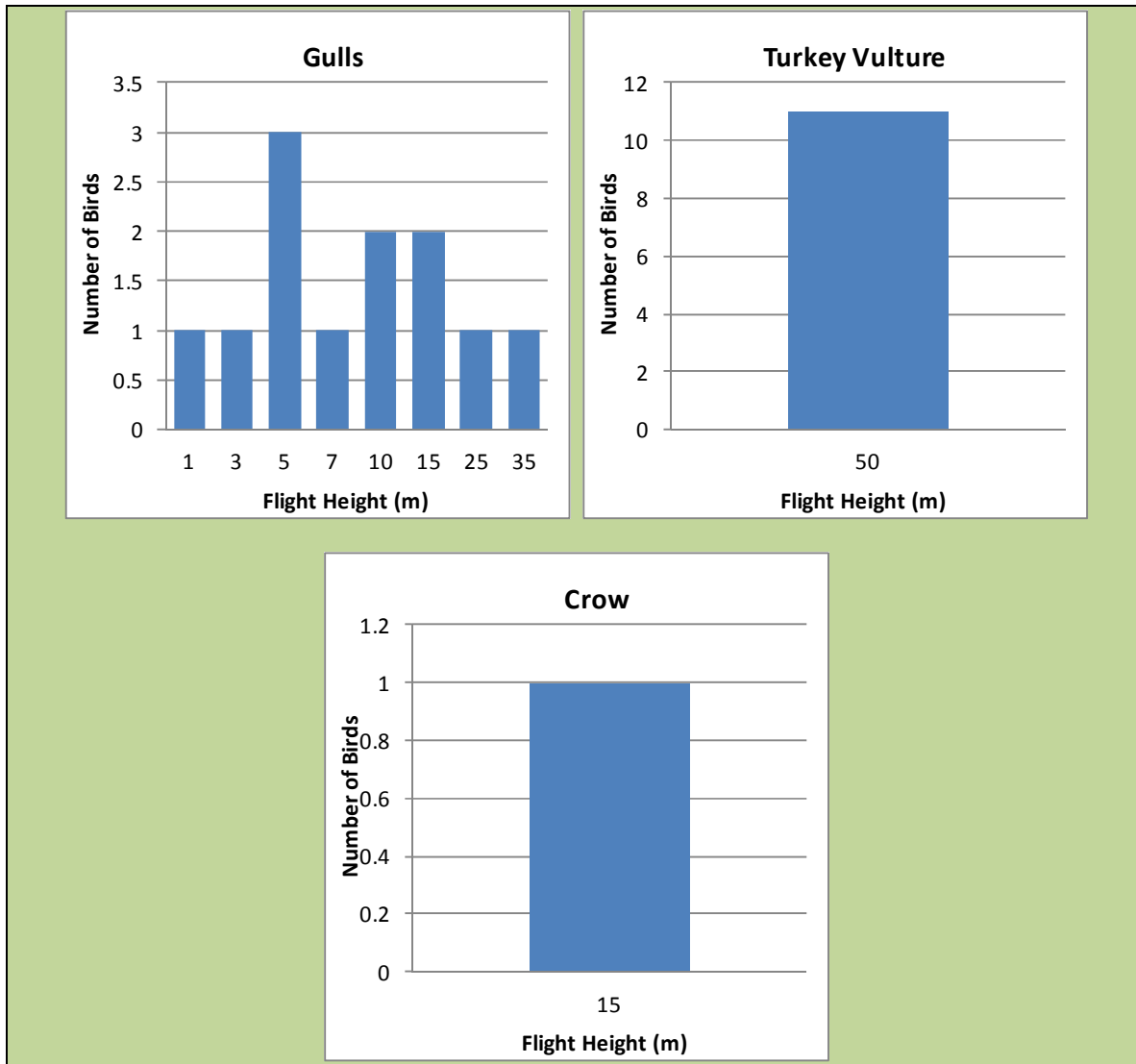


Figure 7. Flight heights of birds by group, demonstrating meandering flight. Neither Group 1: Anseriformes birds or Group 4: Gaviiformes & Suliformes birds exhibited this behavior type.

Figure 7 shows the meandering flight behavior of species grouped by Order. Meandering flight is defined here as a bird flying in ‘wandering’ manner, not directly feeding or moving in a direct manner in a particular direction. Flight direction constantly changes, thus no flight direction is noted in the survey data for these birds.

No birds in Group 1: Anseriformes were observed meandering. Only 12 total gulls were observed meandering for Group 2: Charadriiformes, and 25% meandered at five meters, while 17% meandered at both the 10 and 15m heights.

All 11 birds in Group 3 consisted of a single group of Turkey vultures meandering at the edge of Dice’s Head at 50m above the water’s surface.

No birds representing Group 4 demonstrated meandering behavior and the single crow representing Group 5 meandered at 15m high.

***Meandering Flight Behavior Summary:***

Out of the 24 total birds recorded as demonstrating meandering flight behavior, 11 (46%) were Turkey vultures at 50m (Figure 8). Herring gulls made up 50% of the other meandering birds, ranging from one to 35m high. Similar to milling behavior, no flight direction is typically recorded since the birds have no apparent destination when documented in this behavioral category.

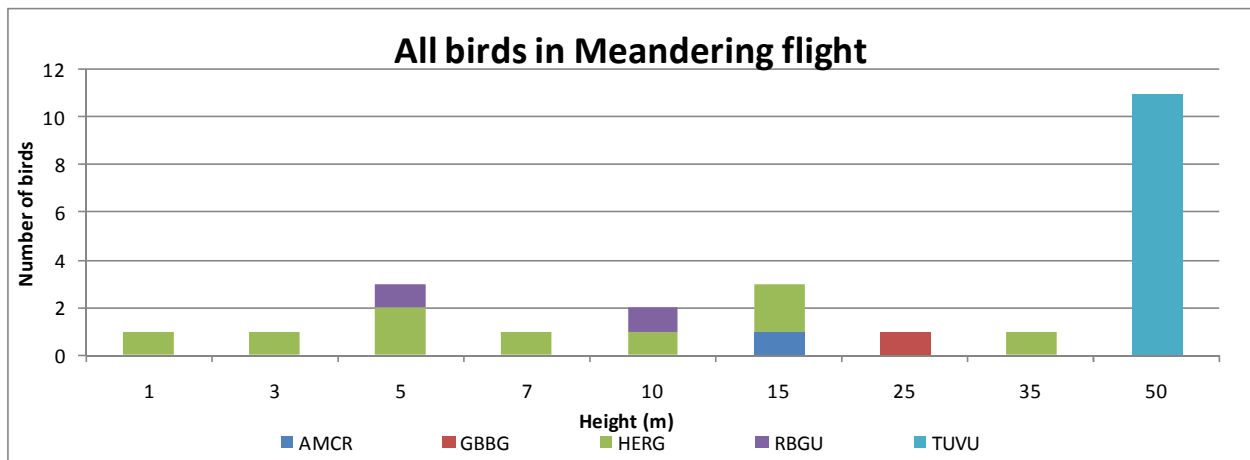


Figure 8. Flight heights and numbers of bird species demonstrating Meandering flight.

**ALL OTHER BEHAVIORS OBSERVED**

Throughout the surveys, 51% of all the recorded birds were observed sitting on the water, which is a behavior category not meant to suggest or exclude feeding activity. This equals 1.94 birds/km<sup>2</sup> sitting within the total survey area. Behaviors described as ‘sitting’ may include sleeping, preening, or resting. Table 39 shows the total numbers of sitting birds by species, separated into the South, North, and BR Quadrats, pooled for all 17 surveys. Fifty percent of all sitting birds were recorded in the South Quadrat (although only totaling about 2 birds/km<sup>2</sup>), 33% were in the BR and included 6.5 birds/km<sup>2</sup>, and the remaining 17% were in the North Quadrat (0.8 birds/km<sup>2</sup>). Species most commonly observed sitting were COEI (48% of all sitting birds), COLO (13%), and BLGU (7%).

Table 39. Species and numbers observed sitting in the water, by quadrat.

Red text denotes Species of Conservation Concern.

Row Labels	S	N	BR	Total
BLSC	1			1
COEI	151	15	79	245
COGO		1		1
RNGR	4	4		8
RBME	4	7		11
UNDU	21	1	3	25
LTDU	2	1	4	7
WWSC		1		1
BLGU	8	3	28	39
<b>RAZO*</b>	<b>2</b>			<b>2</b>
GBBG			1	1
HERG	22	14	37	73
LAGU		2		2
RBGU	4	4		8
DCCO	1		9	10
COLO	28	34	7	69
<b>RTLO*</b>	<b>8</b>	<b>2</b>		<b>10</b>
<b>Grand Total</b>	<b>256</b>	<b>89</b>	<b>168</b>	<b>513</b>

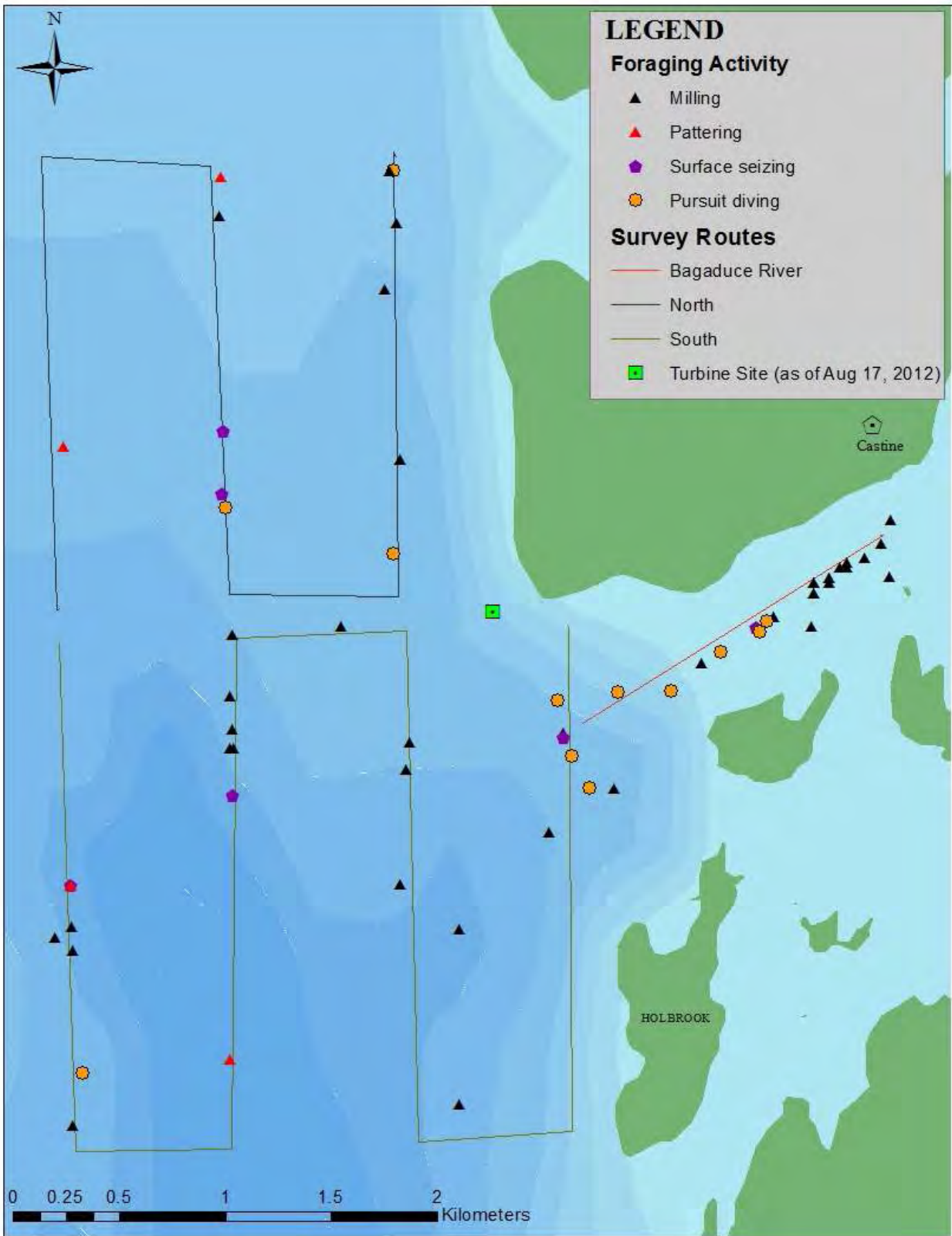
\*Red text indicates Species of Conservation Concern.

The previous discussion focused on behaviors that most likely are not associated with, or due to the brief period of the observed moment, cannot be determined as, foraging activities. Other behaviors are, however, evident activities that involve effort to forage for food either at the surface or below the water. These include dipping or pattering (behavioral code #61), surface seizing (#66), and pursuit diving (#70). Table 40 shows the species and locations of these observed activities, which only involve 37 birds throughout the entire survey season (0.14 birds/km<sup>2</sup>), and represent a mere four percent of all birds recorded. Of these foragers, 51% were active in the South quadrat (0.14 birds/km<sup>2</sup>), 30% were in the BR (0.43 birds/km<sup>2</sup>), and the remaining 19% were in the North quadrat (0.07 birds/km<sup>2</sup>) (Map 24).

Table 40. Numbers and locations of species displaying foraging activities.

SPECIES	SOUTH			NORTH			BR	
	61	66	70	61	66	70	66	70
RBME								2
UNDU								1
BLGU						1		6
BOGU	1							
HERG	1	2					1	
RBGU		12		1				
OSPR				1				
DCCO					1			1
COLO			3		1	1		
<b>RTLO*</b>								<b>1</b>
<b>Grand Total</b>	<b>2</b>	<b>14</b>	<b>3</b>	<b>2</b>	<b>2</b>	<b>3</b>	<b>1</b>	<b>10</b>
<b>Birds/km<sup>2</sup> surveyed</b>	<b>0.14</b>			<b>0.07</b>			<b>0.43</b>	

\*Red text indicates Species of Conservation Concern.



Map 24. Location of foraging bird species throughout the entire survey season.

The birds observed dipping or pattering while flying were only observed in the North and South quadrats, with 50% active in both. Sitting while surface seizing was the most common type of foraging activity, making up 46% of the foraging birds, followed closely by 43% pursuit diving. The surface seizing birds were most prevalent in the South quadrat, with 82% foraging there. Ring-billed gulls constituted 71% of the species foraging in this manner, with 11 of the 12 RBGU recorded on the morning survey of June 29<sup>th</sup> in one location. Of the pursuit divers, as seen in Map 24, the majority occurred in the BR (63%), and the most common species demonstrating this foraging behavior were BLGU (38%) and COLO (19%). Figure 9 shows foraging behaviors for all bird species by activity type and height at which it was observed. Note that the height of “0-m” could also mean under the water activity, but they are all combined to represent activities based off the bird being “in” the water.

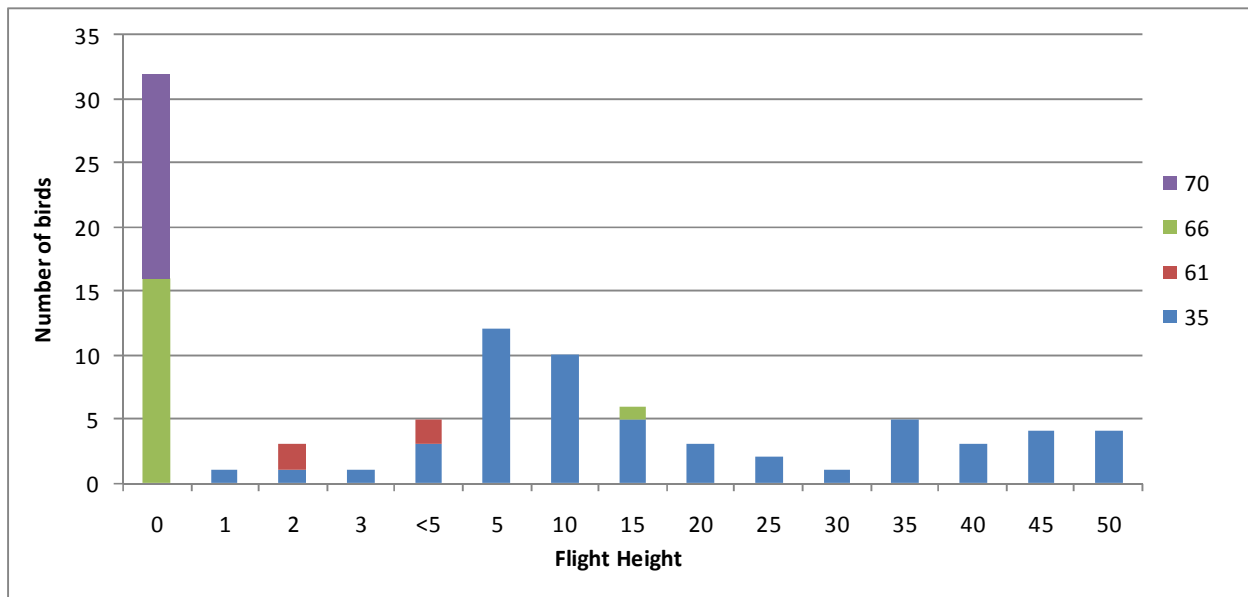


Figure 9. Numbers of all birds demonstrating foraging behaviors and the associated height above the water.

Milling behaviors (behavioral code #35) was discussed in the previous section (Figures 5 & 6), but it is again reviewed in Figure 42 to show common flight heights of all birds involved in the various activities of foraging. This is a detail important to consider due to the birds being potentially preoccupied with searching while flying as opposed to watching for structural hazards. Milling behavior is evidently a common activity, as seen in Map 24, particularly in the BR and South quadrats.

Only five HERG were observed flying while following a boat; two of the gulls were recorded while in the North quadrat and three were in the South quadrat. Although the lobster fishing season for this region begins officially June 1 through October 31, gulls and

many other species of seabirds have become conditioned to the discard or bycatch thrown by fishermen, and are likely to investigate the encounter of a boat despite the calendar year. Three of these boat-following HERG investigated our survey vessel and the two others were investigating another boat within the survey area.

## ENDANGERED, THREATENED, AND BIRDS OF CONSERVATION CONCERN

Biologists have multiple lists that are used for identifying bird species that are of concern to both state and federal wildlife managers. Both state and federally listed species of birds occur in Maine’s waters, including both endangered and threatened species. In an act to potentially alleviate the addition of more species to the Endangered Species Act (ESA) of 1973, the U.S. Fish & Wildlife Service (USFWS) created a list of species requiring special conservation action and awareness: the *Birds of Conservation Concern 2008* (BCC 2008). Bird species discussed in this section include five species found on these lists that were observed during the Castine Harbor Dice Head Test Site surveys from March through June of 2012. For purposes of simplifying terminology, all birds that include the Threatened, Endangered, and Birds of Conservation Concern status, both state and federal, will be called “Birds of Conservation Concern,” or BCC.

Seen below, Figure 10 shows the summary of these species of concern and the activities or behaviors they were observed performing. Only five particular behavior types were observed by these five species, which included the following: 70-foraging below the surface; 35-milling; 20-direct flight; 10-sitting on a floating object; and 1-sitting on the water.

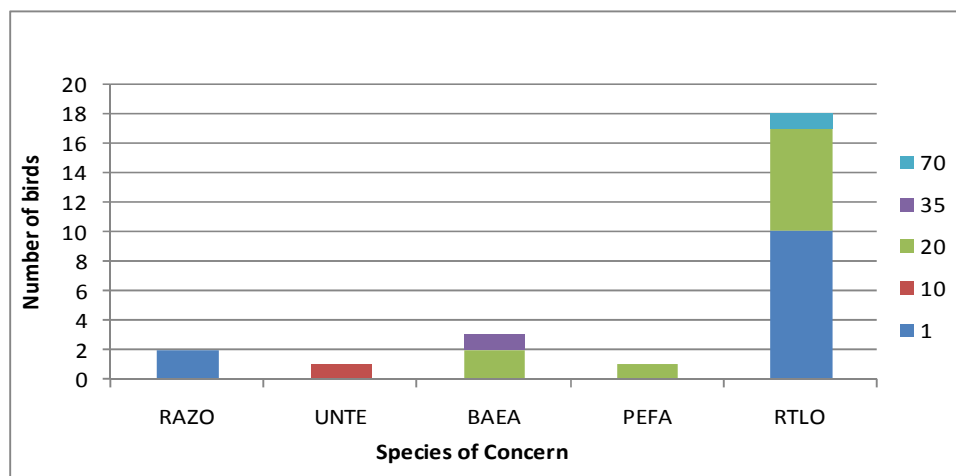


Figure 10. Behavior codes for each species of concern, and numbers observed.

Red-throated Loon (Gavia stellata)

The Red-throated loon was the first recorded species of these birds of concern, and one of the more frequent BCC observed from March 16<sup>th</sup> through May 4<sup>th</sup> (Figure 10 & 11). Considered a Bird of Conservation Concern, it is listed as a “non-breeding species” in the BCC Region #30: New England/Mid Atlantic Coast and USFWS Region 5: Northeast Region. It was the eighth most common species of all birds, with 18 counted across nine observations and equaling 0.07 birds/km<sup>2</sup> for the entire survey season. Table 41 shows total species numbers per kilometer surveyed.

Table 41. All species total count and animals per square kilometer surveyed.

Species	#/km <sup>2</sup>	total
BLSC	0.023	6
CANG	0.011	3
COEI	1.434	379
COGO	0.019	5
COME	0.004	1
GBHE	0.004	1
LTDU	0.034	9
MALL	0.011	3
RBME	0.049	13
RNGR	0.030	8
SUSC	0.034	9
WWSC	0.023	6
UNDU	0.132	35
BLGU	0.216	57
BOGU	0.015	4
GBBG	0.026	7
HERG	0.779	206
LAGU	0.019	5
<b>RAZO*</b>	<b>0.008</b>	<b>2</b>
RBGU	0.155	41
<b>UNTE*</b>	<b>0.004</b>	<b>1</b>

Species	#/km <sup>2</sup>	total
<b>BAEA*</b>	<b>0.011</b>	<b>3</b>
OSPR	0.034	9
<b>PEFA*</b>	<b>0.004</b>	<b>1</b>
TUVU	0.061	16
COLO	0.359	95
DCCO	0.148	39
<b>RTLO*</b>	<b>0.068</b>	<b>18</b>
UNLO	0.004	1
AMCR	0.064	17
BASW	0.011	3
SNBU	0.008	2
SONG	0.008	2
TRES	0.004	1
UNHU	0.004	1
Hseal	0.250	66
GrayS	0.004	1
HAPO	0.129	34

\* Indicates BCC species



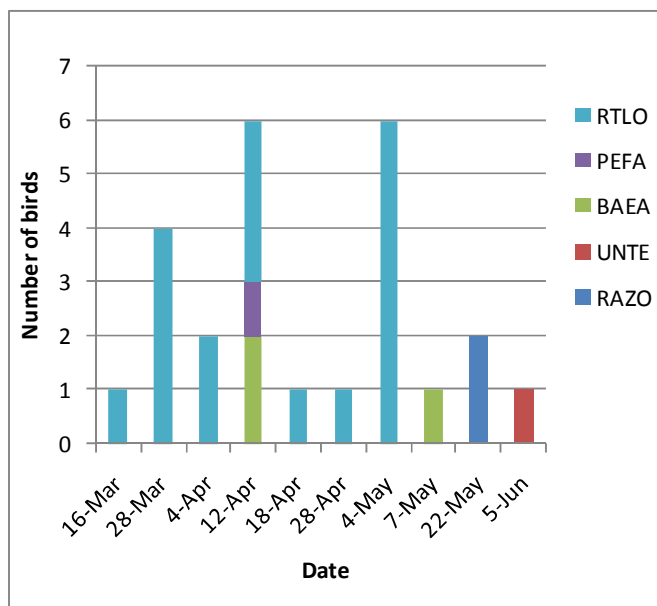


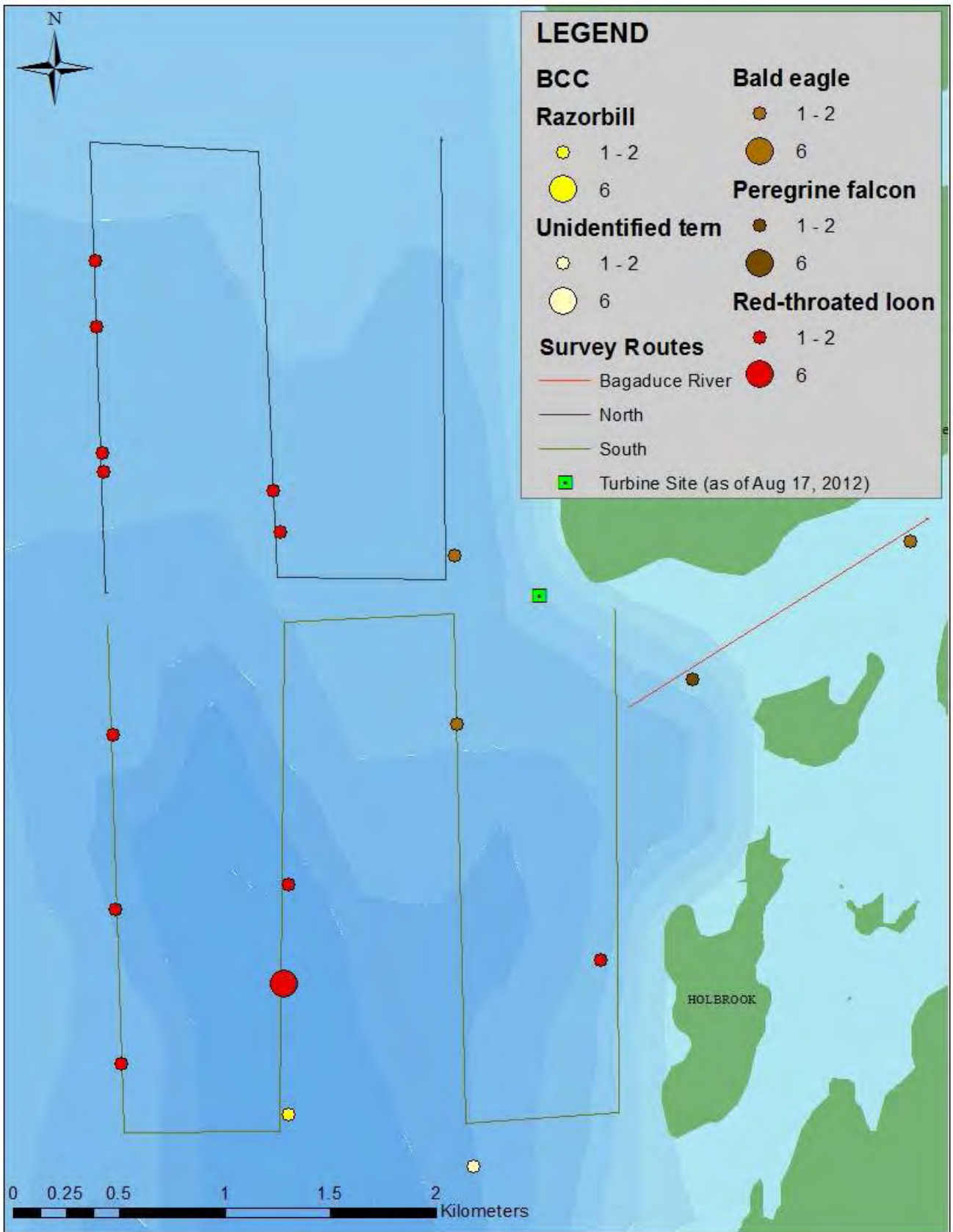
Figure 11. Number and species of Birds of Conservation Concern observed by date.

The majority of the RTLO observed were sitting on the water (56%), 39% were flying in a direct heading, and one bird was actively foraging below the surface in pursuit of prey. Spatially, 67% were located in the South quadrat and the remainder was found in the North quadrat (Map 25).

Bald Eagle (*Haliaeetus leucocephalus*)

Of these five species of concern, the next most common bird was the Bald eagle (0.011 birds/km<sup>2</sup>). Originally listed as a federal and state endangered species under the ESA in 1978, it was downgraded to Threatened in 1995. Its population had recovered enough that by 2007 it was removed from the Federal ESA. It is still protected under Maine’s Endangered Species Act (MESA), the Bald and Golden Eagle Protection Act, the Migratory Bird Treaty Act, the Lacey Act, and listed as a BCC in Region #30: New England/Mid Atlantic Coast and USFWS Region 5: Northeast Region. On February 8, 2011, the USFWS released the Draft Eagle Conservation Plan Guidance to assist agency biologists, developers, and other state and federal organizations in best management practices regarding the Bald Eagle and wind development. It is provided as guidance to assist managers and developers in following the regulations as specified by the Bald and Golden Eagle Protection Act and other federal laws currently in place (USFWS, 2012).

Three sightings of BAEA occurred throughout the survey season, one located within each of the survey quadrats (Map 25). Two separate observations of birds occurred on April 12<sup>th</sup> with each flying direct at 20m high; one in the BR, one in the North. The third observation involved an eagle milling in the South quadrat at 50m on May 7<sup>th</sup>.



MAP 25. Location of Birds of Conservation Concern.

### Peregrine Falcon (*Falco peregrines*)

Another species of concern observed in these surveys was the Peregrine falcon. Also delisted from its status as federally endangered (ESA) in 1999, it continues to be a state endangered species under the MESA, protecting its breeding population only. Their nesting sites are protected during the nesting season from March 15 to August 15 (MDIFW). It is also listed as a BCC in Region #30: New England/Mid Atlantic Coast and USFWS Region 5: Northeast Region.

Only one Peregrine falcon was recorded this season (0.004 birds/km<sup>2</sup>), occurring on the morning of April 12<sup>th</sup> (Figure 11). It flew with direct flight at 30m along the Bagaduce River quadrat, heading due south (Map 25).

### Razorbill (*Alca torda*)

Two Razorbills were also observed (0.008 birds/km<sup>2</sup>), which are listed as state threatened under the MESA. Both birds were recorded in the South quadrat sitting on the water during the afternoon survey on May 22<sup>nd</sup>.

### Tern (*Sterna* sp.)

The last bird species of concern observed during the surveys was an unidentified tern species. Under the MESA, only the Arctic tern (*Sterna paradisaea*) is a state threatened species, and also a BCC in the USFWS Region 5: Northeast Region. Unfortunately, however, due to the inability at the time of observation to verify this bird down to species, it is impossible to know if it was an Arctic tern or Common tern (*Sterna hirundo*); the latter which is not listed as a species of concern. As seen in Map 25 the one tern (0.004 birds/km<sup>2</sup>) was observed in the South quadrat on the morning of June 5<sup>th</sup>, sitting on a floating object.

## **OTHER MISCELLANEOUS OBSERVATIONS**

### Boats & Buoy Observations

Additional observations of boat traffic and lobster buoy presence were also recorded during the surveys. A total of 13 boats were observed while surveys were performed. Six of the boats were various types of sailing vessels, four were assorted private motorized boats, and the remaining three were a fishing vessel for lobster or fish.

Documentation of the buoys was not initiated until the sixth week of surveying, with the first recorded observations starting on April 12<sup>th</sup>. This explains the absence of buoy numbers through March and the first week of April (Table 42). Despite the lack of raw data

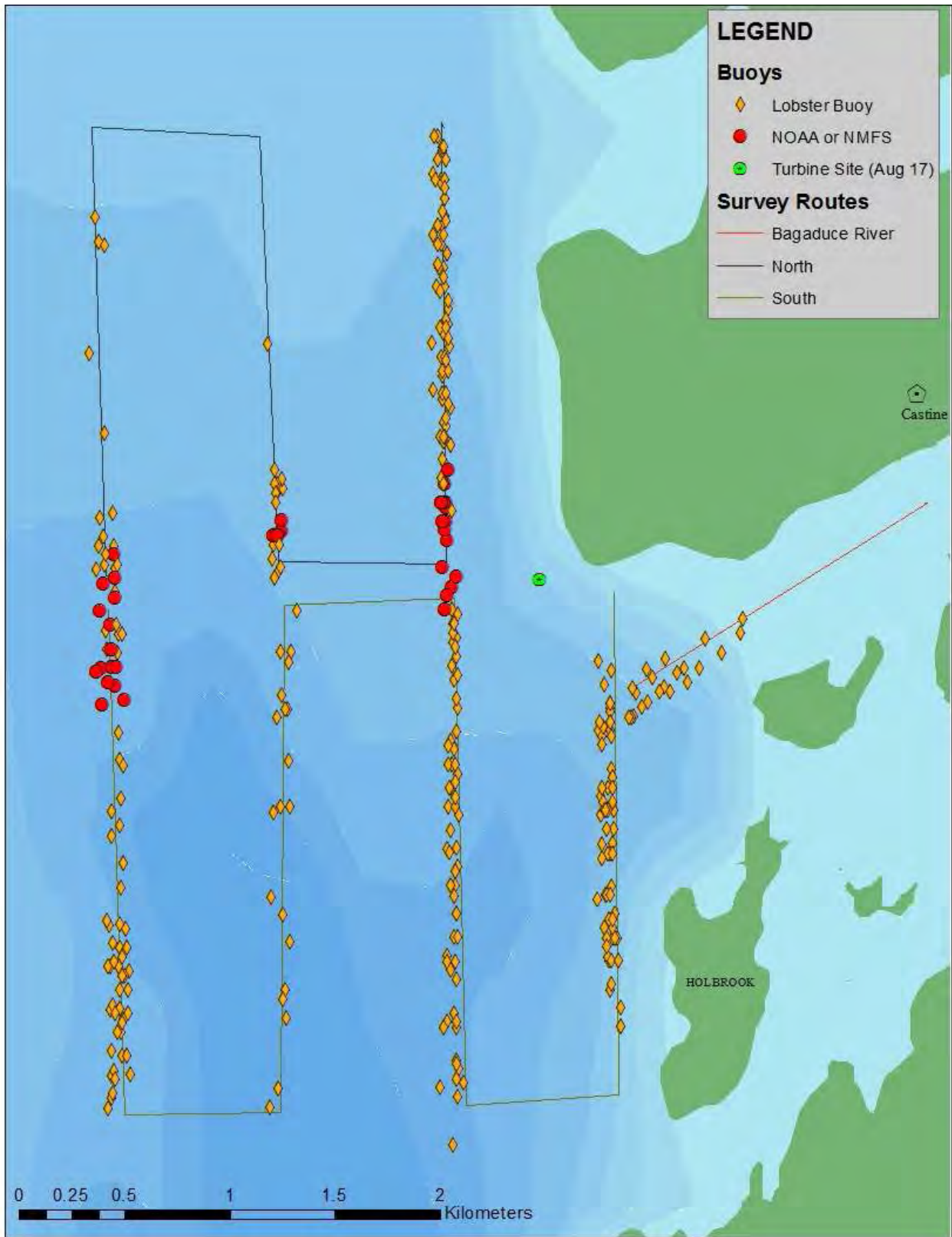
documentation, there *were* buoys present throughout the Castine Test Site during the first six weeks. The buoy densities observed in the first six weeks follow suit as the numbers reflect in Table 42; an increasing temporal trend in buoy density occurred as the season progressed. Among the buoys observed, the majority included the lobster trap buoys, but there were also distinctly-labeled National Oceanographic & Atmospheric Administration (NOAA) and National Marine Fisheries Service (NMFS) buoys also in the area, which were combined into their own category.

The lobster buoys in both the North and South quadrats were observed in fewer numbers at the beginning of March and recorded starting in April (1.27 buoys/km<sup>2</sup> and 1.6 buoys/km<sup>2</sup>, respectively), then increased in number by the end of June (2.9 buoys/km<sup>2</sup> and 3.6 buoys/km<sup>2</sup>). Particularly along the stretch of the Bagaduce River, the number of lobster buoys increased dramatically as the season progressed, from 0.4 buoys/km<sup>2</sup> to 9.9 buoys/km<sup>2</sup>. As seen in Map 26, the greatest abundance of buoys is spatially concentrated closer to land and the Bagaduce River's confluence, with fewer buoys concentrated in the middle of the waterway.

NOAA and NMFS buoys were likely placed for testing purposes related to the Castine Test Site's environmental monitoring, particularly of the existing cable way in which the proposed floating platform will be located. According to our data, buoy numbers reflect an increase in the North quadrat, but a decline in the South quadrat. It is unknown the reasoning for this pattern, but it is likely due to the alteration of the plans of the original placement of the test turbine, as seen in Map 2.

Table 42. Numbers and densities of lobster and other buoys observed in the Castine Test Site, by Quadrat and transect strip number.

DATE	LOBSTER BUOYS												NOAA OR NMFS BUOY										GRAND TOTAL	buoy /km <sup>2</sup>	
	BR Total	buoy /km <sup>2</sup>	N1	N2	N3	North Total (6.3km <sup>2</sup> )	buoy /km <sup>2</sup>	S1	S2	S3	S4	South Total (8.2km <sup>2</sup> )	buoy /km <sup>2</sup>	N1	N2	N3	North Total (6.3km <sup>2</sup> )	buoy /km <sup>2</sup>	S2	S4	South Total (8.2km <sup>2</sup> )	buoy /km <sup>2</sup>			
12-Apr	1	0.62	5	2	4	11	1.75	1	0	5	3	9	1.09	0	0	0	0	0	0	0	0	0	0	21	1.30
18-Apr		0	2	1	6	9	1.43	1	0	0	4	5	0.61	0	0	0	0	0	0	0	0	0	0	14	0.87
28-Apr	1	0.62	1	0	3	4	0.63	*	*	*	5	5	3.11	0	0	6	6	0.95	*	2	2	2	1.24	18	1.89
<b>APRIL TOTALS</b>	<b>2</b>	<b>0.41</b>	<b>8</b>	<b>3</b>	<b>13</b>	<b>24</b>	<b>1.27</b>	<b>2</b>	<b>0</b>	<b>5</b>	<b>12</b>	<b>19</b>	<b>1.60</b>	<b>0</b>	<b>0</b>	<b>6</b>	<b>6</b>	<b>0.32</b>	<b>0</b>	<b>2</b>	<b>2</b>	<b>2</b>	<b>0.41</b>	<b>53</b>	<b>1.35</b>
4-May		0	1	3	10	14	2.22	9	10	1	5	25	3.03	3	1	5	9	1.42	0	1	1	1	0.12	49	3.03
7-May	5	3.1	1	3	8	12	1.90	3	8	1	2	14	1.70	1	1	3	5	0.79	0	1	1	1	0.12	37	2.29
18-May	3	1.86	2	2	7	11	1.75	8	9	0	5	22	2.67	0	1	1	2	0.32	1	1	2	2	0.24	40	2.48
22-May	2	1.24	2	2	5	9	1.43	11	6	2	4	23	2.79	0	0	4	4	0.63	0	1	1	1	0.12	39	2.42
13-May	21	13.05	1	4	36	41	6.51	8	8	3	5	24	2.91	0	0	1	1	0.16	1	2	3	3	0.36	90	5.57
<b>MAY TOTALS</b>	<b>31</b>	<b>3.85</b>	<b>7</b>	<b>14</b>	<b>66</b>	<b>87</b>	<b>2.76</b>	<b>39</b>	<b>41</b>	<b>7</b>	<b>21</b>	<b>108</b>	<b>2.62</b>	<b>4</b>	<b>3</b>	<b>14</b>	<b>21</b>	<b>0.66</b>	<b>2</b>	<b>6</b>	<b>8</b>	<b>0.19</b>	<b>255</b>	<b>3.16</b>	
5-Jun	10	6.22	3	2	13	18	2.86	7	8	0	4	19	2.31	0	1	5	6	0.95	0	1	1	1	0.12	54	3.34
15-Jun	21	13.05	2	2	12	16	2.54	10	6	3	11	30	3.64	0	1	4	5	0.79	0	0	0	0	0	72	4.46
19-Jun	13	8.08	3	4	10	17	2.70	6	6	4	14	30	3.64	0	1	4	5	0.79	0	1	1	1	0.12	66	4.09
29-Jun	21	12.43	1	4	16	21	3.33	15	11	4	8	38	4.61	0	0	1	1	0.16	1	1	2	2	0.24	82	5.08
<b>JUNE TOTALS</b>	<b>64</b>	<b>9.94</b>	<b>9</b>	<b>12</b>	<b>51</b>	<b>72</b>	<b>2.86</b>	<b>38</b>	<b>31</b>	<b>11</b>	<b>37</b>	<b>117</b>	<b>3.55</b>	<b>0</b>	<b>3</b>	<b>14</b>	<b>17</b>	<b>0.67</b>	<b>1</b>	<b>3</b>	<b>4</b>	<b>0.12</b>	<b>274</b>	<b>4.24</b>	
<b>Grand Total</b>	<b>97</b>		<b>24</b>	<b>29</b>	<b>130</b>	<b>183</b>		<b>79</b>	<b>72</b>	<b>23</b>	<b>70</b>	<b>244</b>		<b>4</b>	<b>6</b>	<b>34</b>			<b>3</b>	<b>11</b>			<b>582</b>		



Map 26. Buoy locations, both lobster and NOAA or NMFS, including the proposed Test Turbine Platform location (as of August 17, 2012).

## SUMMARY

March through June of 2012 was regarded as the pre-deployment stage of the single 20kW wind turbine on a 1/7<sup>th</sup> commercial scale floating platform project at the University of Maine’s Castine Harbor Dice Head Test Site. During this time, a total of 17 boat-based visual surveys were performed at a rate of one per week. Data were gathered on species of birds and, occasionally, marine mammals and turtles, to include location, occurrence, numbers, bird behaviors, flight direction, and flight heights. Fulfilling the primary objective of this project, the previous sections summarized the species numbers, activities, and presented maps of their sightings. We will further summarize the highlights of this season’s surveys. Table 43 lists each survey quadrat by total species counted and total survey area for both birds and marine mammals.

Table 43. Numbers of bird species and marine mammals per kilometer surveyed in each quadrat.

		North	South	BR	Totals
<b>BIRDS</b>	# of Species	257	492	260	1009
	Area	131.51km <sup>2</sup>	107.10 km <sup>2</sup>	25.74 km <sup>2</sup>	264.35 km <sup>2</sup>
		<b>1.95 birds/ km<sup>2</sup></b>	<b>4.59 birds/ km<sup>2</sup></b>	<b>10.1 birds/ km<sup>2</sup></b>	<b>3.82 birds/ km<sup>2</sup></b>
<b>MARINE MAMMALS</b>	# of Species	23	65	13	101
	Area	131.51 km <sup>2</sup>	107.10 km <sup>2</sup>	25.74 km <sup>2</sup>	264.35 km <sup>2</sup>
		<b>0.18 mammals/km<sup>2</sup></b>	<b>0.61 mammals/km<sup>2</sup></b>	<b>0.51 mammals/km<sup>2</sup></b>	<b>0.38 mammals/km<sup>2</sup></b>

There were a total of 464 observations of birds recorded with a grand total of 1,009 individuals counted throughout the entire Castine Harbor Dice Head Test Site, representing 33 identified species (refer to Appendix 2 through 4 for further specifics). As previously presented in Table 41, the most numerous of bird species during the entire survey period were Common Eider (38%, 1.43 birds/km<sup>2</sup>), followed by Herring gulls (20%, 0.78 birds/km<sup>2</sup>) and Common loons (9%, 0.36 birds/km<sup>2</sup>). The three quadrats surveyed within the Castine Test site revealed 49% of all bird sightings were located within the South quadrat (4.59 birds/km<sup>2</sup>), with nearly identical numbers of individuals counted in the North and Bagaduce River quadrats (25.8% and 25.5%, respectively), although almost five times more birds per kilometer were found in the BR than in the South (10.1 birds/km<sup>2</sup> and 1.95 birds/km<sup>2</sup>, respectively).

The most common activities observed by the birds were sitting (51%) with 1.94 birds/km<sup>2</sup> recorded throughout the entire survey area, followed by direct flight (36%) with 1.39 birds/km<sup>2</sup> recorded. Milling (foraging) flight represented 5.5% of all bird activity (0.21 birds/km<sup>2</sup>), followed by meandering flight (2.4%; 0.09 birds/km<sup>2</sup>), sitting while foraging/dipping (1.7%; 0.06 birds/km<sup>2</sup>), and pursuit diving (foraging) (1.6%; 0.06 birds/km<sup>2</sup>).

Flight heights for all flying activities (456 birds, 45% of total observed) are shown in Figure 12. Most of the flying birds (40%) flew one meter above the surface, totaling 0.69 birds/km<sup>2</sup>. The second most common flight height was at five meters, with 10.7% (0.19 birds/km<sup>2</sup>), followed closely by 10% at 10m (0.17 birds/km<sup>2</sup>) and 8.8% at 15m (0.15 birds/km<sup>2</sup>).

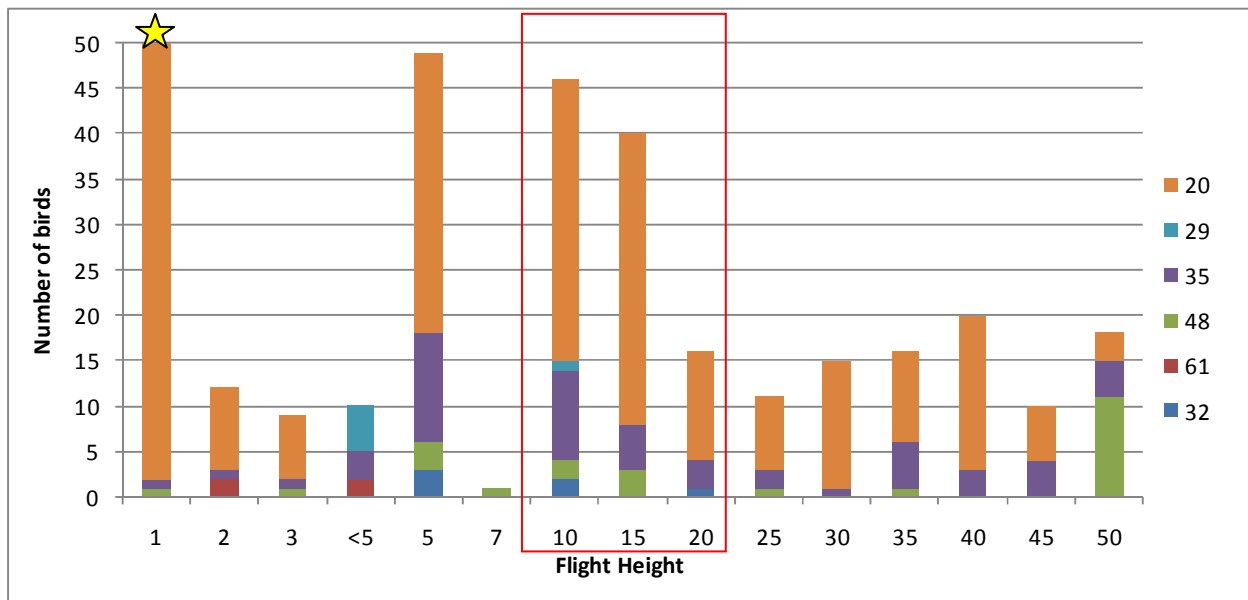


Figure 12. Flight heights for all flying behaviors for all species. The yellow star represents a total of 183 birds flying at one meter high.

Endangered and threatened species sightings included two Razorbills and one unidentified tern (Group 2: Charadriiformes); three Bald eagles and one Peregrine falcon (Group 3: Accipiteriformes and Falconiformes); and 18 Red-throated loons (Group 4: only the Order Gaviiformes).

No turtles were observed in the Castine Test Site, but a total of 101 marine mammals were counted during 80 observations, consisting of one Gray seal, 66 Harbor



seals, and 34 Harbor porpoise. Sixty-four percent of all marine mammals were found in the South quadrat, with 0.61 mammals/km<sup>2</sup>. Although more individuals were counted in the North (23%) than in the BR (13%), more mammals per kilometer were in the BR (0.51/km<sup>2</sup>) than in the North (0.18/km<sup>2</sup>) quadrat.

The secondary objective of this project was to use the initial baseline inventory of the species composition, behaviors, and habitat use for assessment of potential risks to the wildlife in relation to the proposed single 20kW wind turbine on a 1/7<sup>th</sup> commercial scale floating platform off Dice Head near Castine.

Birds may experience four major types of impact caused by offshore wind farms: direct collision, displacement due to disturbance, displacement due to the barrier effect, and direct habitat loss (Drewitt & Langston 2006, Goodale & Divoll 2009). A fifth impact involves habitat enhancement due to the underwater structure acting as an artificial reef and potentially attracting piscivorous seabirds; however this can only be a net benefit if the birds are not frightened away or killed by the structure itself (Drewitt & Langston 2006). In the case of the Castine Harbor Dice Head Test Turbine, the structure, and the project itself, is relatively small in both spatial and temporal contexts. Nevertheless, discussion will follow that summarizes any potential impact that the single VoltturnUS 20kW wind turbine on a 1/7<sup>th</sup> commercial scale floating platform may present to the wildlife in the Castine Harbor Dice Head area.

Current literature discusses how the probability of impacts, particularly with collisions, is more dependent upon individual species and their unique behaviors (Drewitt & Langston 2006, Ferrer et al. 2012, Furness & Wade 2012). These considerations should also take into account the local topographic factors which influence wind patterns and prey availability, as opposed to the common investigation of local abundance (Ferrer et al. 2012). Incorporating the correct scale factor of the individual turbine versus the entire proposed development site into the protocol of the pre- and post-development surveys is imperative to best analyzing the potential impacts to the birds (Ferrer et al. 2012). Again, this particular project at the Castine Harbor Dice Head Test Site is very small, consisting of the single 1/7<sup>th</sup> scale turbine and therefore the potential scale of the impact is also small. The protocol and analysis used in this project encompasses both the focused region of the single turbine's location but also considers the larger region, which could potentially cover dispersal by species if the impact of displacement, due to disturbance, occurs (Drewitt & Langston 2006).

Numerous Wind farm Sensitivity Index (WSI) studies in Europe and North America agree that the species at most risk to offshore wind farms include gulls, grebes, loons, seaducks, and migrating waterfowl and passerines (Drewitt & Langston 2006, Furness &

Wade 2012, Garthe & Hüppop 2004). A newer analysis by Furness & Wade further categorized impacts to particular species, concluding high disturbance scores for Common eider, loons, and scoter species (easily disturbed, high tendency to flush); high collision impact scores for gulls, terns, and loons; and high overall disturbance and displacement scores for loons, sea ducks, and alcids (Furness & Wade 2012). With Common eider, Herring gulls, and Common loons being the three most abundant species during our surveys, consideration should be made for their presence and activity near the Castine Harbor Dice Head Test Site.

Flight height was determined to be a substantial factor in assessing collision probabilities by Furness & Wade in their review of Scottish seabird sensitivity to offshore wind farms (2012). According to our latest information regarding the single VoltturnUS 20kW wind turbine on a 1/7<sup>th</sup> commercial scale floating platform on August 17, 2012, its hub height measures 50ft (15.24m), with a rotor diameter of 31.5ft (9.6m). This equals a total height from waterline to highest blade tip to be 20m, and the rotor sweep zone ranging from 10m above the water’s surface to 20m. For purposes of bird collision or risks, it is necessary to consider the Castine Harbor Dice Head avian flight activity in this flight height-zone. Table 44 provides the species and numbers that were observed flying at the heights recorded within the 10m to 20m zone, which totals 22.4% of all flying birds. Herring gulls, Ring-billed gulls, and Common loons were the most common species to be flying at these heights.

Table 44. Species and numbers recorded flying within the rotor sweep-zone.

SPECIES	FLIGHT HEIGHTS (m)		
	10	15	20
UNDU	3		
AMCR		1	1
BASW		1	
BLSC		2	
CANG	3		
COEI		2	2
GBBG	1	1	
<b>HERG</b>	<b>22</b>	<b>28</b>	<b>7</b>
LAGU	1		
MALL	3		
<b>BAEA*</b>			<b>2</b>
<b>RBGU</b>	<b>4</b>	<b>2</b>	<b>2</b>
SNBU			2
TRES	1		
OSPR	1		
DCCO	1		
<b>COLO</b>	<b>6</b>	<b>3</b>	
<b>RTLO*</b>		<b>1</b>	
<b>Total</b>	<b>46</b>	<b>41</b>	<b>16</b>

\*Red text indicates Species of Conservation Concern.

Because bird behavior is not a random event, it is essential to incorporate the influence of wind patterns and topography of the area that birds use for foraging, migration, and other movements (Drewitt & Langston 2006, Ferrer et al. 2012, Garthe & Hüppop 2004). The general topography of the waters around the Castine area is characterized by a north-south opening of the land where the Penobscot River empties into Penobscot Bay. Castine has nine miles (14.5km) of open waters extending across to the west side of the Bay, where Belfast is located. The islands of Isleboro, North Haven, and Vinal Haven lie in the middle of the Bay, from north to south. From the outer edge of the Gulf of Maine, a south wind would travel almost 20 miles (32km) across these islands to reach Castine. As provided in Table 2, the wind directions across the 17 surveyed days can be generalized by month: March, typically SE winds; April, NW; May, S; and June equally N and S. Figure 13 includes a summary of the directions flown by all flying birds. Southerly winds typically prevailed during the majority of these days, and a higher proportion of flying birds were observed flying due N, NW, NE, and E.

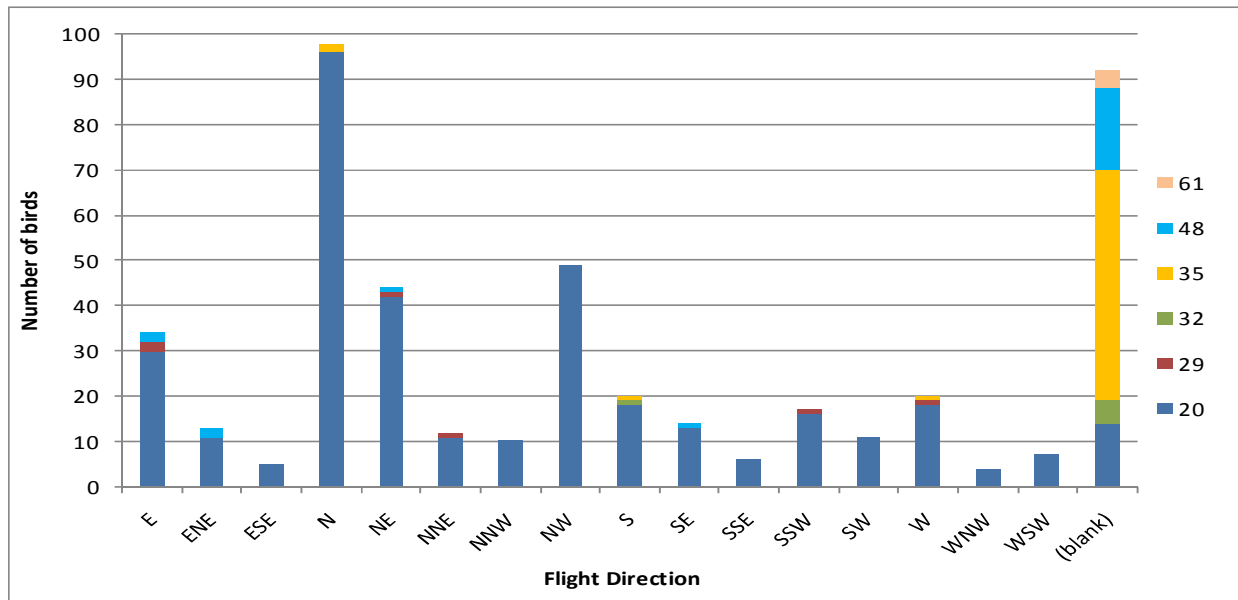


Figure 13. Flight direction and numbers of birds, color-coded by behavior type.

As for Species of Conservation Concern, two Bald eagles and one Red-throated loon were documented as flying within the rotor-sweep zone between 10m and 20m above the water (Table 44). Of the 456 flying birds, 23% (0.39 birds/km<sup>2</sup>) flew between the 10m and 20m rotor sweep zone, as indicated by the red box in Figure 12. To further categorize bird use of the survey quadrats, these birds flying within this rotor-sweep zone were mostly found in the South quadrat (46%), followed by the North (30%) and BR quadrats (24%).

Maine-specific considerations for wind farm development have been suggested by the BioDiversity Research Institute to include three main criteria: 1) avoid critical breeding, wintering, and migratory areas, 2) avoid offshore islands that provide breeding areas for seabirds and are essential migratory staging areas, and 3) avoid areas within three kilometers of these first two criteria to prevent serious impact to birds of special concern (Goodale & Divoll 2009).

Fortunately this recommended distance by Goodale & Divoll (2009) contains only a minimal portion of the Bagaduce River watershed that includes habitat on the Castine peninsula (Map 3); Hatch Cove that is part of the MTPI Significant Wildlife Habitat for Shorebird Nesting, Feeding, and Staging Area (Map 4); and MDIFW Essential Habitat Bald eagle nest sites (Map 4). However, according to Charlie Todd, MDIFW eagle biologist, the most recent Bald eagle nest sites, as of 2011, were located to the east of Holbrook Island on the mainland of South Brooksville (Map 27), and therefore located at the edge of this suggested buffer zone. Last performed in 2008, a statewide eagle survey is scheduled for April 2013, which will provide more updated eagle nesting location data (C. Todd, *pers. comm.*, Sept 20, 2012), and should be incorporated into the impact assessments for this project.



Map 27. Locations of most recent Bald Eagle nest sites (210B & 210D). Map courtesy of C.Todd (MDIFW).

A future objective regarding the planned deployment of the single VoltornUS 20kW wind turbine on a 1/7<sup>th</sup> commercial scale floating platform will be to compare this season's data to the following year when the turbine will be deployed. Data will assess species composition and behavior changes, if any, to the presence of the structure and its necessary maintenance. Appropriate monitoring in both the pre- and post-deployment stages provides the data necessary to recognize if impacts to species of concern exist and if appropriate remedial measures are required.

Although abundance alone is not a factor of concern for impact to the birds of the Castine Harbor Dice Head Test site, the high numbers of Common eider and Common loons observed during this season's surveys will be an interesting subset of data to compare to the upcoming deployment season. For example, numbers of Common eider, loons, alcids, and seaducks decreased after installation of wind farms at two Danish wind farms (Petersen et al. 2004 *in* Drewitt & Langston 2006), and in other reviews by Goodale & Divoll (2009) similar results were found for many seaducks and loon species. A high tendency for avoidance by most Anseriformes species decreases the risk of collision; however, it can be equated to habitat loss.

Due to carcasses sinking or being consumed by opportunistic predators, detection probabilities are low for birds that may be killed by collision, *if* they do occur with the small single turbine. However, the high abundance of Herring and Ring-billed gulls recorded in this season's survey, and particularly the numbers flying at the rotor-sweep heights from 10m to 20m, coincide with the high level of concern for collision impact rankings developed by Furness & Wade (2012).

Therefore, it is advised that particular consideration be given to changes in species composition, abundance, and behavior that could be attributed to the presence of the test turbine. These surveys are essential to an understanding of the impact of alternative energy development projects. Streamlining their appropriate use and cooperatively mitigating the resulting impacts will benefit both humans and seabirds.

## **ACKNOWLEDGEMENTS**

I would like to thank Maine Maritime Academy and the dedicated captains for their flexibility and accommodating spirit to make these surveys happen: Dana Willis, Hanna Gray, and Derek Chase. Also, for the help and continuing support from Gordon Longfellow at the College of the Atlantic, whose open door and educational collaboration is a blessing to small businesses like me. Additional resources and assistance also included Derek Lovitch (Freeport Wild Bird Supply), Charlie Todd (MDIFW biologist), and Adrienne Leppold. Logistical, professional, and encouraging support was most graciously provided by Damian Brady and Diane Mosely (UMO staff), for helping us all to plow through the beginning stages of this project and make it possible and beneficial to all. Thank you.

**APPENDIX 1**  
**SURVEY CODES**  
(Gould & Forsell 1989)

**Code 2. Survey Type (15)**

- 1 = General observations: These are records of large flocks, rare or unusual sightings, transects that cannot be used to derive density indexes, or any record that will not fit another format.
- 7 = Station count: The criteria for a station count are that the platform is stationary and that all birds are counted in a 360° circle from the platform.
- 9 = Ocean transect: The criteria for a transect are a visibility of at least 1,000m and a moving platform with a constant speed and direction. An oceanic-transect is conducted outside well-defined headlands.

**Code 3. Observation Conditions (75)**

- 1 = Bad (general observations only)
- 2 = Poor (no quantitative analysis)
- 3 = Fair
- 4 = Average
- 5 = Good
- 6 = Excellent
- 7 = Maximum

**Code 5. Sea State (49)**

- 0 = Calm
- 1 = Rippled (0.0 1-0.25 ft)
- 2 = Wavelet (0.26-2.0 ft)
- 3 = Slight (2-4 ft)
- 4 = Moderate (4-8 ft)
- 5 = Rough (8-13 ft)
- 6 = Very rough (13-20 ft)
- 7 = High (20-30 ft)
- 8 = Over 30 ft

**Code 6. Weather (55-56)**

- 00 = Clear to partly cloudy (0-50% cloud cover)
- 03 = Cloudy to overcast (51-100% cloud cover)
- 41 = Fog (patchy)
- 43 = Fog (solid)
- 68 = Rain
- 71 = Snow
- 87 = Hail

**Code 14. Age (32)**

- P = Pullus (flightless young)
- J = Hatching year (hatching date to spring molt: a bird capable of sustained flight)
- S = Subadult (last year before adult plumage)
- A = Adult

**Code 17. Bird Behavior (56-57)**

- 00 = Undetermined
- 01 = Sitting on water
- 10 = Sitting on floating object
- 15 = Sitting on land
- 20 = Flying in direct & consistent heading
- 29 = Flying, height variable
- 31 = Flying, circling ship
- 32 = Flying, following ship
- 34 = Flying, being pirated
- 35 = Flying, milling or circling (foraging)
- 48 = Flying, meandering
- 61 = Feeding at or near surface while flying (dipping or pattering)
- 65 = Feeding at surface (scavenging)
- 66 = Feeding at or near surface, not diving or flying (surface seizing)
- 70 = Feeding below surface (pursuit diving)
- 71 = Feeding below surface (plunge diving)
- 82 = Feeding above surface (pirating)
- 90 = Courtship display
- 98 = Dead

**Code 18. Mammal Behavior (56-57)**

- 00 = Undetermined
- 01 = Leaping
- 02 = Feeding
- 03 = Mother with young
- 04 = Synchronous diving
- 05 = Bow riding
- 06 = Porpoising
- 07 = Hauled out
- 08 = Sleeping
- 09 = Avoidance
- 14 = Curious/following
- 15 = Cetacea/pinniped association
- 16 = Pinniped/bird association
- 17 = Cetacea/bird association
- 18 = Breeding/copulation
- 19 = Moribund/dead

**APPENDIX 2. Species listed by most abundant to least abundant, including total numbers and total observations, and most common behavior type.**

Species	Abundance per km <sup>2</sup>	Total number	Number of observations	Most common behavior
COEI	1.434	379	28	sitting
HERG	0.779	206	154	direct flight
COLO	0.359	95	75	sitting
BLGU	0.216	57	48	sitting
RBGU	0.155	41	29	sitting, surface seize
DCCO	0.148	39	26	direct flight
UNDU	0.132	35	12	sitting
<b>RTLO*</b>	<b>0.068</b>	<b>18</b>	<b>13</b>	<b>sitting</b>
AMCR	0.064	17	11	direct flight
TUVU	0.061	16	3	meandering
RBME	0.049	13	3	sitting
LTDU	0.034	9	5	direct flight
SUSC	0.034	9	4	direct flight
OSPR	0.034	9	7	direct flight
RNGR	0.030	8	3	sitting
GBBG	0.026	7	7	direct flight
BLSC	0.023	6	5	direct flight
WWSC	0.023	6	4	direct flight
COGO	0.019	5	3	direct flight
LAGU	0.019	5	4	sitting, direct flight
BOGU	0.015	4	2	direct flight
CANG	0.011	3	1	direct flight
MALL	0.011	3	1	direct flight
<b>BAEA*</b>	<b>0.011</b>	<b>3</b>	<b>3</b>	<b>direct flight</b>
BASW	0.011	3	3	direct flight
<b>RAZO*</b>	<b>0.008</b>	<b>2</b>	<b>1</b>	<b>sitting</b>
SNBU	0.008	2	1	direct flight
SONG	0.008	2	1	direct flight
COME	0.004	1	1	milling
GBHE	0.004	1	1	direct flight
<b>UNTE*</b>	<b>0.004</b>	<b>1</b>	<b>1</b>	<b>sitting</b>
<b>PEFA*</b>	<b>0.004</b>	<b>1</b>	<b>1</b>	<b>direct flight</b>
UNLO	0.004	1	1	direct flight
TRES	0.004	1	1	direct flight
UNHU	0.004	1	1	direct flight

\*Red text indicates BCC species.



### APPENDIX 3

All observed species with code, common name, scientific name, and dates sighted.

Species Code	Common name	Scientific name	March				April				May				June			
			7	16	20	28	4	12	18	28	4	7	18	22	31	5	15	19
AMCR	American crow	<i>Corvus brachyrhynchos</i>	X	X	X	X		X				X	X					
BAEA*	Bald eagle	<i>Haliaeetus leucocephalus</i>						X				X						
BASW	Barn swallow	<i>Hirundo rustica</i>						X				X						
BLGU	Black guillemot	<i>Cephus grylle</i>	X	X	X	X	X	X	X	X	X			X	X		X	X
BLSC	Black scoter	<i>Melanitta nigra</i>			X		X		X				X	X				
BOGU	Bonaparte's gull	<i>Larus philadelphia</i>											X					X
CANG	Canada goose	<i>Branta canadensis</i>												X				
COEI	Common eider	<i>Somateria mollissima</i>	X	X	X	X	X	X		X	X							
COGO	Common goldeneye	<i>Bucephala clangula</i>				X	X		X									
COLO	Common loon	<i>Gavia immer</i>	X	X	X	X	X	X		X	X	X	X	X	X		X	X
COME	Common merganser	<i>Mergus merganser</i>																X
DCCO	Double-crested cormorant	<i>Phalacrocorax auritus</i>		X					X	X	X	X		X	X	X	X	X
GBBG	Great black-backed gull	<i>Larus marinus</i>		X				X				X	X		X	X		
GBHE	Great blue heron	<i>Ardea herodias</i>												X				
HERG	Herring gull	<i>Larus argentatus</i>	X	X	X	X	X	X	X	X	X	X	X	X	X	X	X	X
LAGU	Laughing gull	<i>Leucophaeus atricilla</i>								X	X		X					
LTDU	Long-tailed duck	<i>Clangula hyemalis</i>	X	X		X		X						X				
MALL	Mallard	<i>Anas platyrhynchos</i>			X													
OSPR	Osprey	<i>Pandion haliaetus</i>						X			X					X	X	X
PEFA <sup>†</sup>	Peregrine falcon	<i>Falco peregrines</i>						X										
RAZO <sup>‡</sup>	Razorbill	<i>Alca torda</i>										X						

\* Delisted from the Federal Endangered Species Act. † State endangered species under the Maine Endangered Species Act. ‡ State threatened species under the Maine Endangered Species Act.

**APPENDIX 3 (cont'd)**

Species Code	Common name	Scientific name	March				April				May					June			
			7	16	20	28	4	12	18	28	4	7	18	22	31	5	15	19	29
RBME	Red-breasted merganser	<i>Mergus serrator</i>				X					X								
RNGR	Red-necked grebe	<i>Podiceps grisegena</i>		X	X		X												
RTLO <sup>¥</sup>	Red-throated loon	<i>Gavia stellata</i>		X		X	X	X	X										
RBGU	Ring-billed gull	<i>Larus delawarensis</i>				X					X	X	X	X	X	X		X	
SNBU	Snow bunting	<i>Plectrophenax nivalis</i>					X												
SONG	Unidentified songbird										X								
SUSC	Surf scoter	<i>Melanitta perspicillata</i>			X		X					X							
TRES	Tree swallow	<i>Tachycineta bicolor</i>									X								
TUVU	Turkey vulture	<i>Cathartes aura</i>				X		X	X										
UNDU	unidentified duck species		X	X		X	X		X		X							X	
UNHU	Unidentified hummingbird										X								
UNLO	Unidentified loon	<i>Gavia sp.</i>		X															
UNTE <sup>x</sup>	Unidentified tern	<i>Sterna sp.</i>													X				
WWSC	White-winged scoter	<i>Melanitta fusca</i>				X						X		X		X			
GrayS	Gray seal	<i>Halichoerus gypus</i>																X	
Hseal	Harbor seal	<i>Phoca vitulina</i>		X	X		X	X	X		X	X	X	X	X	X	X	X	
HAPO	Harbor porpoise	<i>Phocoena phocoena</i>			X	X					X	X		X	X			X	

<sup>¥</sup> non-breeding species in the Birds of Conservation Concern (BCC), Bird Conservation Region #30: New England/Mid Atlantic Coast and USFWS Region 5: Northeast Region.

<sup>x</sup> only the Arctic tern is considered state threatened: MDIFW and BCC listed, but it is unknown exactly which tern species this observation was.

**APPENDIX 4**

**All observed species, by date, time of day, and number recorded.**

Total	Species	7-Mar	16-Mar	20-Mar	28-Mar	4-Apr	12-Apr	18-Apr	28-Apr	4-May	7-May	18-May	22-May	31-May	5-Jun	15-Jun	19-Jun	29-Jun
	Time	AM	PM	AM	PM	AM	AM	PM	AM	AM	PM	AM	PM	AM	AM	PM	PM	AM
6	BLSC			2		1		1					1	1				
3	CANG													3				
379	COEI	1		102	8	91	89	44		14	27			3				
5	COGO				2	2		1										
1	COME																	1
1	GBHE													1				
9	LTDU	2	1		2			3						1				
3	MALL			3														
13	RBME				2						11							
8	RNGR		2	4		2												
9	SUSC			2		2						5						
6	WWSC				1							3		1		1		
35	UNDU	1	2		6	3		3			19							1
57	BLGU	2	6	11	1	1	4	16	1	2	4			3	4		1	1
4	BOGU												3					1
7	GBBG		1				1				1	2		1	1			
206	HERG	9	9	10	10	7	18	23	12	7	10	11	5	15	40	4	7	9
5	LAGU									1	2		2					
2	RAZO												2					
41	RBGU				2						2	7	5	4	1	3		17
1	UNTE														1			
3	BAEA						2				1							
9	OSPR							2			2					2	2	1
1	PEFA						1											
16	TUVU				11		2	3										
95	COLO	3	8	10	13	6	2	4		16	7	9	1	11	1		1	3
39	DCCO		1						5	4	3	13		4	2	2	2	3
18	RTLO		1		4	2	3	1	1	6								
1	UNLO		1															
17	AMCR	3	3	6	2		1					1	1					
3	BASW						1				2							
2	SNBU					2												
2	SONG										2							
1	TRES										1							
1	UNHU										1							
66	Hseal		2	7		3	1	5		10	7	11	5	3	2	2	1	7
1	GrayS																	1
34	HAPO			2	3						2	2		14	2			9
1110		21	37	159	67	122	125	106	19	60	104	64	25	65	54	14	14	54

## LITERATURE CITED

- Beginning With Habitat. (2012) "Focus Areas of Statewide Ecological Significance: Bagaduce River," 5 pp. [http://www.maine.gov/doc/nrimc/mnap/focusarea/bagaduce\\_river\\_focus\\_area.pdf](http://www.maine.gov/doc/nrimc/mnap/focusarea/bagaduce_river_focus_area.pdf)
- Berleant, A. "\$1 million grant for Bagaduce River arrives with strings attached." *Castine Patriot*, April 5, 2012.
- Biodiversity Research Institute (2012). "Birds, Bats, and Coastal Windfarm Development in Coastal Maine: Preliminary Ranking of Bird Use." *Biodiversity Research Institute*. Retrieved July 29, 2012, from <http://www.briloon.org/oe/the-science-of-bri/tracking-wildlife/birds-bats-costal-windfarm-development>
- Drewitt, A.L, and R.H.W. Langston. 2006. Assessing the impacts of wind farms on birds. *Ibis* 148: 29-42.
- Ferrer, M., M. de Lucas, G.F.E. Janss, E.Casado, A.R. Muñoz, M.J. Bechard, and C.P. Calabuig. 2012. Weak relationship between risk assessment studies and recorded mortality in wind farms. *Journal of Applied Ecology* 49: 38-46.
- Furness, B. and H. Wade. 2012. Vulnerability of Scottish seabirds to offshore wind turbines. MacArthur Green Ltd. Report. 39 pp.
- Garthe, S. and O. Hüppop. 2004. Scaln possible adverse effects of marine wind farms on seabirds: developing and applying a vulnerability index. *Journal of Applied Ecology* 41: 724-734.
- Goodale W. and T. Divoll. 2009. Birds, Bats and Coastal Wind Farm Development in Maine: A Literature Review. Report BRI 2009-18. BioDiversity Research Institute, Gorham, Maine. 40pp. Also available online at <http://www.briloon.org/oe/the-science-of-bri/tracking-wildlife/birds-bats-costal-windfarm-development>
- Gould, P.J. & D.J. Forsell. 1989. Techniques for shipboard surveys of marine birds. U.S. Fish & Wildlife Service, *Fish & Wildl. Technical Report* 25, 22 pp.
- Kennedy, L. & Holberton, R.L. 2012. "Visual Observations for Birds, Turtles, and Marine Mammals at the University of Maine Test Site off Monhegan Island, a report submitted to the Maine State Planning Office and University of Maine. "
- Maine Department of Conservation. Updated 2001. *Checklist of the Birds: Holbrook Island Sanctuary* [Pamphlet]. Brooksville, Maine: Maine Department of Conservation, Bureau of Parks and Lands.
- Maine's Department of Inland Fisheries & Wildlife (MDIFW) Endangered Species Program/Bird List ([http://www.maine.gov/ifw/wildlife/species/endangered\\_species/bird\\_list.htm](http://www.maine.gov/ifw/wildlife/species/endangered_species/bird_list.htm))
- Maine Tidal Power Initiative's Site Resource Assessment (2011). Published Habitat Map: Bagaduce Narrows and Castine Harbor, Maine. "Significant Wildlife and Essential Habitats." *University of Maine: Maine Tidal Power Initiative*.
- Tasker, M.L., P.H. Jones, T. Dixon, & B.F. Blake. 1984. Counting seabirds at sea from ships: A review of methods employed and a suggestion for a standardized approach. *The Auk* 101: 567-577.

USFWS Species of Conservation Concern 2008. U.S. Fish and Wildlife Service. 2008. *Birds of Conservation Concern 2008*. United States Department of Interior, Fish and Wildlife Service, Division of Migratory Bird Management, Arlington, Virginia. 85 pp. [Online version available at <<http://www.fws.gov/migratorybirds/>>]

USFWS (January 9, 2012). Guidance regarding use of the Wind Turbine Guidelines Advisory Committee's recommendations. *Wind Turbine Guidelines Advisory Committee: Habitat and Resource Conservation*. Retrieved September 23, 2012, from [http://www.fws.gov/habitatconservation/windpower/wind\\_turbine\\_advisory\\_committee.html](http://www.fws.gov/habitatconservation/windpower/wind_turbine_advisory_committee.html)

USFWS (July 6, 2012). Bald Eagle Management Guidelines and Conservation Measures. *U.S. Fish & Wildlife Services: Ecological Services*. Retrieved September 20, 2012, from <http://www.fws.gov/northeast/EcologicalServices/eagle.html>

# Visual Observations for Birds, Turtles, and Marine Mammals at the University of Maine Test Site near Castine, Maine.



*A report submitted to the University of Maine's Advanced Structures and Composites Center*

*JULY-DECEMBER 2013*

*by*

**LAURA KENNEDY, MS**

*Lubird Kennedy Environmental Services*

Bar Harbor, Maine

[lubirdkennedy@yahoo.com](mailto:lubirdkennedy@yahoo.com)

918-549-5625

# TABLE OF CONTENTS

I.	Executive Summary.....	1
II.	Introduction .....	2
III.	Location.....	4
IV.	Methods.....	7
V.	AUGUST – DECEMBER 2013 Results.....	10
	A. Surveys by day.....	14
	1. August 7 Survey, afternoon.....	14
	2. August 14 Survey, morning .....	16
	3. August 21 Survey, afternoon.....	17
	4. August 28 Survey, morning .....	19
	5. September 4 Survey, afternoon .....	20
	6. September 11 Survey, afternoon .....	22
	7. September 18 Survey, morning.....	23
	8. October 2 Survey, afternoon.....	25
	9. October 9 Survey, morning .....	26
	10. October 16 Survey, afternoon.....	28
	11. October 23 Survey, morning .....	30
	12. October 30 Survey, afternoon.....	31
	13. November 4 Survey, morning.....	33
	14. November 13 Survey, afternoon.....	35
	15. December 3 Survey, afternoon .....	37
	16. December 9 Survey, morning.....	39
	17. December 20 Survey, morning.....	41
	B. Species Abundance and Diversity.....	43
	C. Bird Behavior Categories.....	45
	1. Sitting .....	45
	2. Direct Flight Behavior .....	45
	3. Milling Flight Behavior.....	47
	4. Meandering Flight Behavior .....	48
	5. Foraging & Other Behaviors .....	50
	D. Endangered, Threatened, and Birds of Conservation Status.....	53
	E. Marine Mammals.....	57
	F. Boats & Buoys .....	58
VI.	Summary .....	60
	A. Objective #1 .....	60
	B. Objective #2 .....	62
VII.	Acknowledgements .....	68
VIII.	Literature Cited .....	71

## TABLES:

Table 1.	Most common behavior codes .....	9
Table 2.	Surveys by time of day and corresponding weather conditions .....	10
Table 3	Species codes, scientific names, and densities.....	11
Table 4.	Species of special conservation designation (SCC) .....	12
Table 5.	Number of species Aug 7.....	14
Table 6.	Behaviors Aug 7 .....	14
Table 7.	Number of species Aug 14.....	16

Table 8.	Behaviors Aug 14.....	16
Table 9.	Number of species Aug 21.....	17
Table 10.	Behaviors Aug 21.....	17
Table 11.	Number of species Aug 28.....	19
Table 12.	Behaviors Aug 28.....	19
Table 13.	Number of species Sept 4.....	20
Table 14.	Behaviors Sept 4.....	20
Table 15.	Number of species Sept 11.....	22
Table 16.	Behaviors Sept 11.....	22
Table 17.	Number of species Sept 18.....	23
Table 18.	Behaviors Sept 18.....	23
Table 19.	Number of species Oct 2.....	25
Table 20.	Behaviors Oct 2.....	25
Table 21.	Number of species Oct 9.....	26
Table 22.	Behaviors Oct 9.....	27
Table 23.	Numbers of species Oct 16.....	28
Table 24.	Behaviors Oct 16.....	28
Table 25.	Number of species Oct 23.....	30
Table 26.	Behaviors Oct 23.....	30
Table 27.	Number of species Oct 30.....	31
Table 28.	Behaviors Oct 30.....	32
Table 29.	Numbers of species Nov 4.....	33
Table 30.	Behaviors Nov 4.....	33
Table 31.	Number of species Nov 13.....	35
Table 32.	Behaviors Nov 13.....	36
Table 33.	Number of species Dec 3.....	37
Table 34.	Behaviors Dec 3.....	38
Table 35.	Numbers of species Dec 9.....	39
Table 36.	Behaviors Dec 9.....	40
Table 37.	Number of species Dec 20.....	41
Table 38.	Behaviors Dec 20.....	42
Table 39a-d.	Species abundance by quadrat and month.....	43
Table 40.	Densities and behaviors by quadrat.....	45
Table 41.	Densities and flight height in Direct Flight.....	46
Table 42.	Densities and flight height in Milling Flight.....	47
Table 43.	Densities and flight height in Meandering Flight.....	49
Table 44.	Foraging species abundance by quadrat.....	50
Table 45.	Species of Conservation Status, from greatest to least densities, by quadrat and total.....	55
Table 46.	Species of Conservation Status by quadrat.....	55
Table 47.	Species of Conservation Status by behavior.....	56
Table 48.	Marine mammals by date and quadrat.....	57
Table 49.	Species-group potential reaction to spinning turbine.....	65

## MAPS:

Map 1.	Castine and Penobscot Bay in Maine with survey tracks.....	2
Map 2.	Location of the Castine Test Site.....	3
Map 3.	Bagaduce River Watershed.....	5
Map 4.	New England Tidal Power Initiative Map of Significant Wildlife and Essential Habitats.....	6
Map 5.	Castine Test Site survey track lines.....	8
Map 6.	August 7 observations.....	15
Map 7.	August 14 observations.....	15
Map 8.	August 21 observations.....	18
Map 9.	August 28 observations.....	18



Map 10.	September 4 observations .....	21
Map 11.	September 11 observations .....	21
Map 12.	September 18 observations .....	24
Map 13.	October 2 observations .....	24
Map 14.	October 9 observations .....	27
Map 15.	October 16 observations .....	29
Map 16.	October 25 observations .....	29
Map 17.	October 30 observations .....	32
Map 18.	November 4 observations .....	34
Map 19.	November 13 observations .....	36
Map 20.	December 3 observations.....	38
Map 21.	December 9 observations.....	40
Map 22.	December 20 observations.....	42
Map 23 a-e.	Bird abundance by month .....	44
Map 24 a-e.	Species of Conservation Status by month .....	54
Map 25.	Marine mammals .....	57
Map 27.	Boats and buoys .....	59

## FIGURES:

Figure 1.	Direct flight by species-group.....	46
Figure 2.	Milling flight by species-group .....	48
Figure 3.	Meandering flight by species-group.....	49
Figure 4.	Foraging behavior by quadrat .....	51
Figure 5.	Foraging flight height by quadrat .....	52
Figure 6.	Species of Conservation Status within the Rotor Sweep Zone .....	56
Figure 7.	Boat type by quadrat.....	58
Figure 8.	Boat abundance by date and quadrat .....	58
Figure 9.	Flight height by species-group and behavior type.....	61
Figure 10.	All flying birds within the Rotor Sweep Zone .....	64

## APPENDICES:

Appendix 1.	Behavioral codes (Gould & Forsell 1989) .....	69
Appendix 2.	Comparative surveys of densities of all wildlife by month, year, and quadrat.....	70

## **Public Use Statement**

This report contains data collected through federal funds provided by the University of Maine's Advanced Structures and Composites Center (Ct-07B-20111024\*2017). While the information provided in this report is meant for public access, permission is required to reproduce figures, tables, and any other product contained within this report without the express permission of the University of Maine's Advanced Structures and Composites Center.

Suggested citation for this report:

Kennedy, L. 2013d. "Visual Observations for Birds, Turtles, and Marine Mammals at the University of Maine Test Site near Castine, Maine; August - December 2013. A report submitted to the University of Maine's Advanced Structures and Composites Center. "

## I. Executive Summary

Seventeen boat-based surveys were conducted from August to December of 2013 at the University of Maine's Castine Harbor Dice Head Test Site near Castine, Maine. The primary objective is to record baseline pre-deployment observations of seabirds and other wildlife at this location. Observations included species, number, behavior, flight height and direction, as well as weather and sea conditions. The secondary objective is to use this information to assess potential risk or behavior conflicts that may occur due to the presence of the VoltturnUS 20kW wind turbine on a 1/8th commercial scale floating platform and its operations and maintenance.

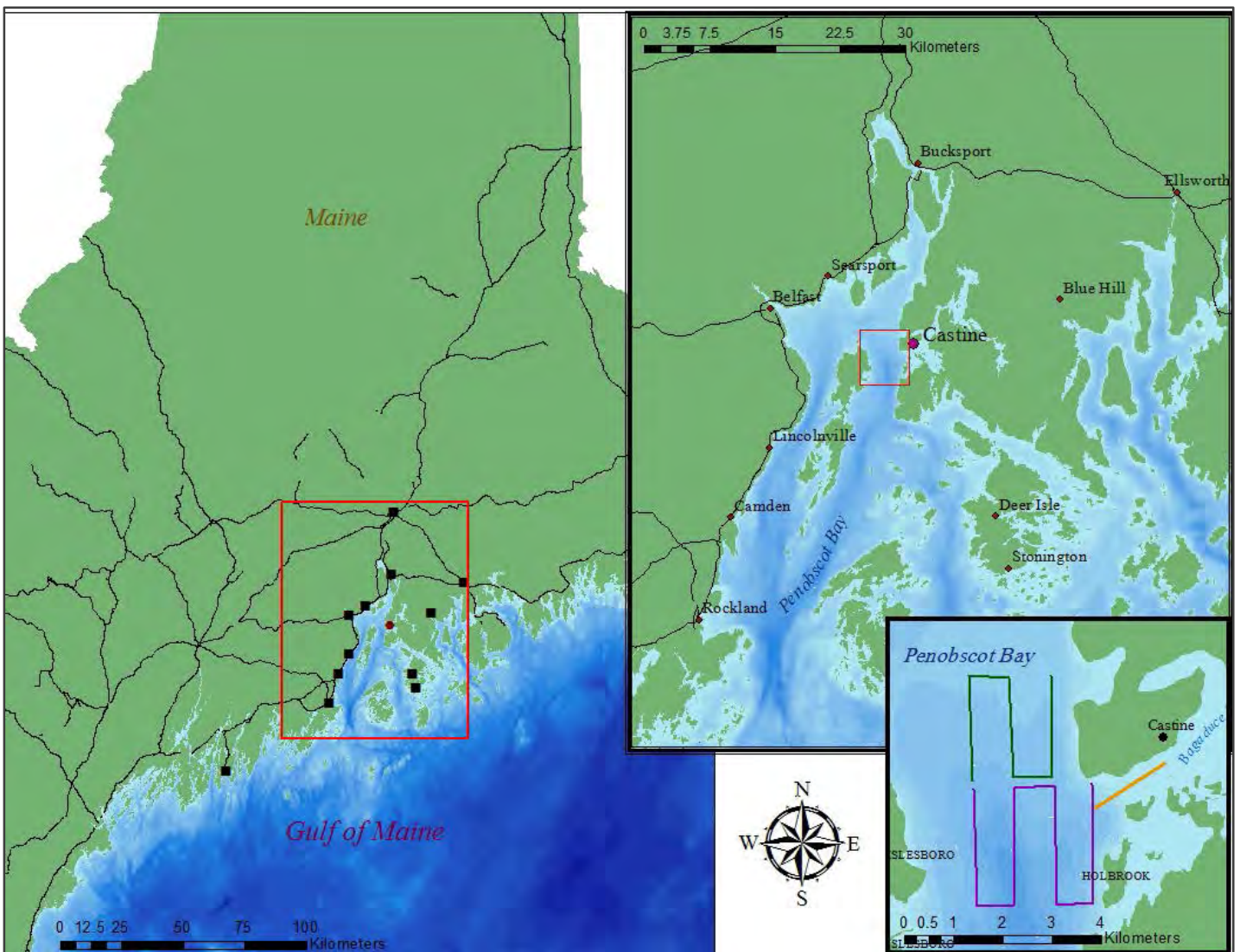
Throughout these 17 surveys in 2013, 1,839 birds were recorded and 112 marine mammals. The five most prevalent bird species were black guillemot (*Cephus grille*, BLGU; n=248, 2.4/km<sup>2</sup>), common eider (*Somateria mollissima*; n=193, 2.3/km<sup>2</sup>), Bonaparte's gull (*Larus philadelphia*; n=394, 2.1/km<sup>2</sup>), herring gull (*L. argentatus*, HERG; n=350, 1.9/km<sup>2</sup>), and ring-billed gull (*L. delawarensis* n=227, 1.2/km<sup>2</sup>). The razorbill (*Alca torda*) was the only state-threatened species of concern identified (n=7, 0.02/km<sup>2</sup>), and seven other species or potential species with a USFWS or MDIFW conservation designation were recorded such as unidentified terns, shorebirds, ducks, and alcids.

The most common bird behaviors included sitting on the water (23% were BLGU and 21% were BOGU), direct flight (18% were HERG and 14% were COEI), and milling flight (41% were BOGU and 33% were HERG). Of the flying birds, 36% flew at one meter, and 24% flew at the next common height of five meters. Among the species of concern, 88% flew at or below five meters, well under the danger of spinning blade collisions.

Although the test turbine is small-scale, gulls may have the greatest potential for impact due to higher abundances in the area and flight heights more commonly found within the Rotor Sweep Zone of 10-20m. Within this zone, all flying bird species comprised 17%, of which 87% involved Group 2: Charadriiformes. Foragers within these heights involve 27% of the flying birds and 92% of them are again in Group 2C. These numbers potentially increase their susceptibility to collision with the turbine blades. However, when investigating potential avoidance of the spinning blades, a cursory review of abundances during blade-spinning versus not-spinning days potentially shows gulls avoiding the north quadrat compared to their presence in the remaining two quadrats. Contrary to other literature, ducks, sea ducks, cormorants, and loons in our survey showed a slight increase in abundance in the north quadrat on days in which the blades were spinning compared to the other quadrats, although unlikely significant.

## II. INTRODUCTION

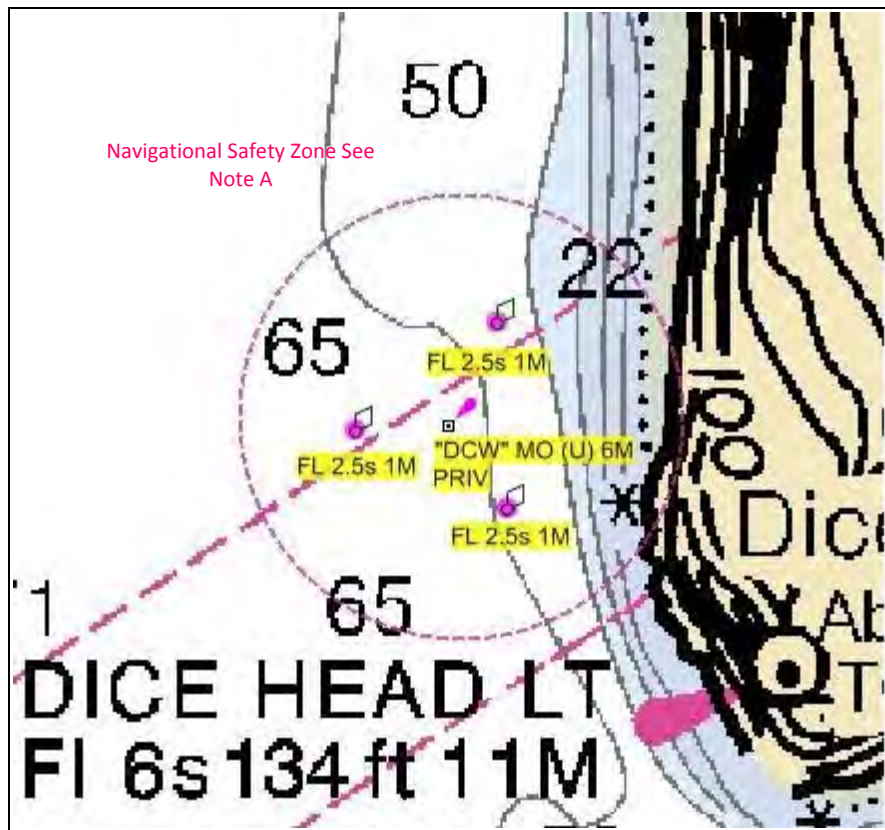
The Gulf of Maine (GOM) is a well-known avian corridor for the millions of songbirds, raptors, shorebirds, wading birds, and waterfowl to pass through during the spring and fall migration (Goodale & Divoll 2009). Over 300 documented species of all major avian taxa frequent the GOM region and more data is currently being accumulated that supports a growing list of known-wintering species. For the purposes of this report, our area of focus lies near Castine, ME midway along Maine's coast at the mouth of the Penobscot River, in Penobscot Bay (Map 1).



Map 1. Castine and Penobscot Bay in Maine, with survey region inside the smaller red box in inset maps.

This survey was initiated as a request for pre- and during-deployment data at the Castine Test Site to be used in the environmental assessment for DeepCwind's VoltturnUS 1/8 scale turbine test unit on a semi-submersible floating platform. Specific information pertaining to the flight heights, behaviors, and species found near the Dice Head Lighthouse area helps to better understand the birds' habitat use of the site (e.g., feeding, resting, and passing through the area). It also helps to assess potential risks as a result of human activities associated with the siting, construction, operation, and removal of turbine structures. Resource agencies such as the Maine Department of Inland Fisheries and Wildlife (MDIFW) and the United States Fish and Wildlife Service (USFWS) consider monitoring bird activity with respect to offshore wind development a high priority (USFWS Wind Turbine Guidelines Advisory Committee, 2012).

The location of the VoltturnUS 1/8th scale semi-submersible floating platform turbine is found at N44°23'8", W68° 49' 32" in the waters 1,000ft (305m) off Dice's Head at Castine, Maine, in an existing cableway (Map 2).



Map 2. Location of Castine Test Turbine Site near Castine, Maine. Map courtesy of University of Maine's Navigation Safety Plan, D.Chase.

The primary objectives of this study include 1) determining bird and marine wildlife species compositions and their current activities and habitat use of the Castine Harbor Dice Head Test Site, and 2) using this information to assess potential risk or behavior conflicts that may occur due to the presence of the University of Maine's VoltturnUS 20kW wind turbine on a 1/8<sup>th</sup> commercial scale floating platform and its operations and maintenance. Data will assess species composition and behavior changes, if any, to the presence of the structure. These risks will include potential collision with both above and below surface structures such as blades and platform anchoring lines, or the use of the platform structure for wildlife to roost upon. Other potential behavioral conflicts may arise due to the operational boat traffic and other sources of increased human presence, or additional structure presence.

This report summarizes ongoing baseline data of the VoltturnUS turbine's deployment at the University of Maine's Castine Test Site that occurred as of June 6, 2013. The structure consists of a single 20 kW test turbine that measures 20m tall (65.6ft) at the highest blade tip, sitting on a floating tension leg platform and connects to the electric grid via an underwater cable. The rotor diameter measures 31.5ft (9.6m), creating a Rotor Sweep Zone from 10m to 20m from the water's surface.

### **III. LOCATION**

Castine lies on the west side of the Blue Hill peninsula and on the north-west bank of the Bagaduce River, which is a 12-mile (19.3km) stretch of flowing tidal water that converges into Penobscot Bay. The BioDiversity Research Institute ([www.briloon.org](http://www.briloon.org)) has created a Ranking of Bird Use map that categorizes areas from High to Low bird use. The numerous islands that lie at the outer edge of Penobscot Bay, particularly on the tip of the Blue Hill Peninsula, have a concentrated zone of High bird use. Further up the bay, however, near Castine and in the area surveyed in this report, bird use rates as "Low" (BRI, 2012).

Two important areas of this region of the Blue Hill Peninsula and Penobscot Bay are considered "Significant Wildlife Areas": the Bagaduce River watershed and Holbrook Island Sanctuary.

Like the GOM region, the Penobscot Bay region contains important and diverse ecosystems for many species of birds, invertebrates, fish, and shellfish, largely due to the Bagaduce River's ecological significance (Map 3). Because of this abundance of wildlife and habitat, the Bagaduce River Watershed has been designated by the Beginning with Habitat

(BwH) organization ([www.beginningwithhabitat.org](http://www.beginningwithhabitat.org)) as a “Focus Area of Statewide Ecological Significance” that includes Significant Wildlife Areas for Inland Wading Bird and Waterfowl Habitat, Tidal Wading bird and waterfowl habitat, and Significant Shorebird Area (BwH, 2012). Map 3 shows the location of the VoltturnUS 1/8<sup>th</sup> scale floating test turbine site, which is not inside the Bagaduce River watershed, but is in the vicinity.



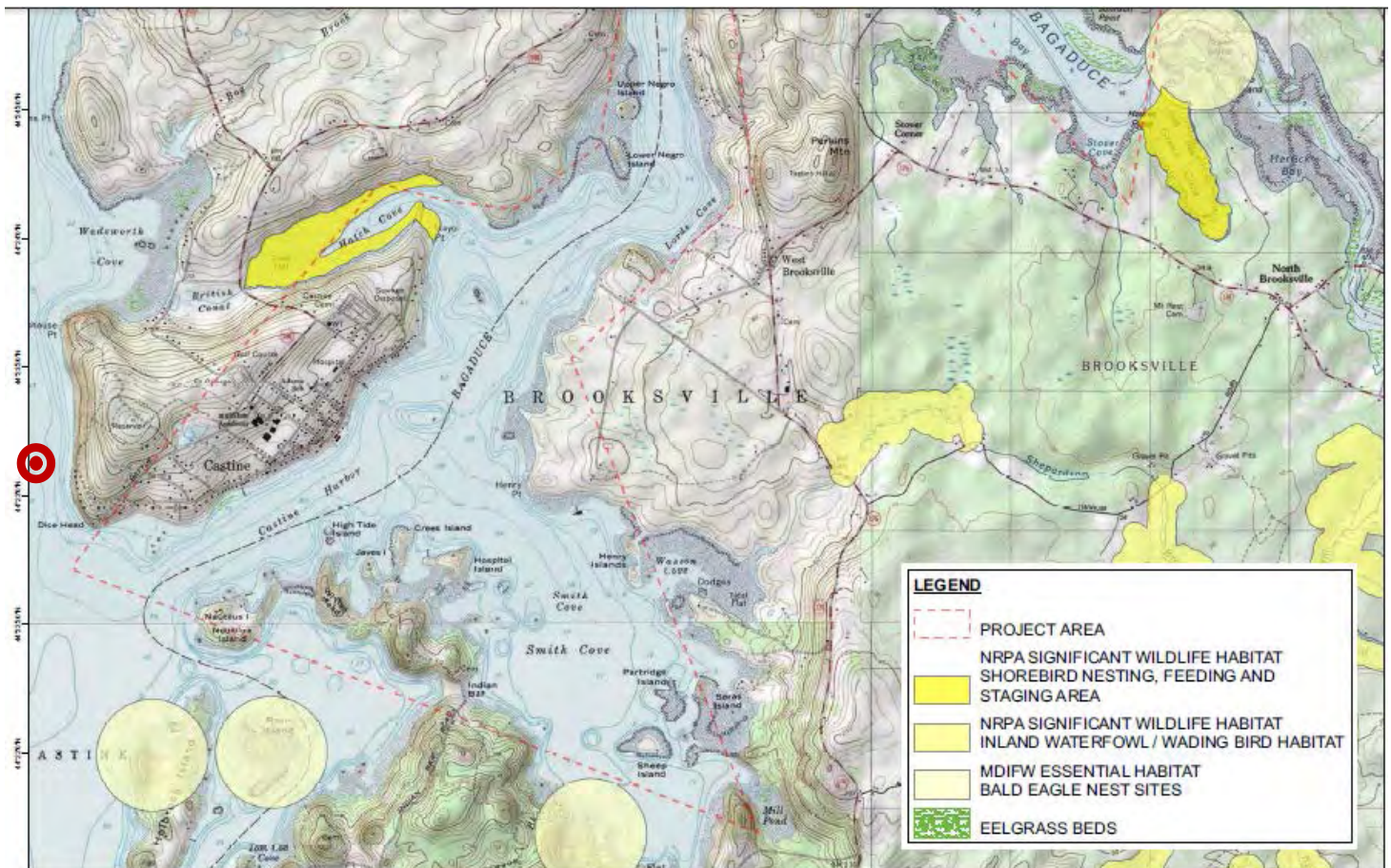
Map 3. The Bagaduce River Watershed. Map courtesy of *Beginning With Habitat* ([www.beginningwithhabitat.org](http://www.beginningwithhabitat.org)). The purple circle represents the Castine Harbor Dice Head Turbine Test site location.

Not only is the area of the Bagaduce River’s 2,700 acres available for waterfowl and wading birds’ feeding, breeding, and migratory stopover, but it is also one of a few locations in Maine where American horseshoe crabs (*Limulus polyphemus*) are known to breed (BwH, 2012). In April of 2012, the Maine Coast Heritage Trust received a large federal matching grant to further wetland habitat conservation and land protection efforts in the Bagaduce River watershed due to its important bird habitat status (Berleant 2012). Due to the shallow open waterways and strong tides that help resist freezing in the winter, migrating and wintering waterfowl take refuge in the protected coves of the river.

In a collaborative effort with the University of Maine, the Maine Tidal Power Initiative’s Site Resource Assessment (MTPI, 2012) has located specific coves and marshes that provide “NRPA Significant Wildlife Habitat for Shorebird Nesting, Feeding, and Staging Areas” as well as for “Inland Waterfowl & Wading Bird Habitat” within the Bagaduce River’s pathway. As seen in Map 4, the nearest significant habitats to the proposed Castine Harbor Dice Head Test Turbine location are some eel grass beds located in Wadsworth Cove (green patches), a large shorebird nesting, feeding and staging area in Hatch Cove

(yellow area), and two tan circles south of Dice Head that represent previously-known Bald eagle (*Haliaeetus leucocephalus*; BAEA) nest sites, circa 2012.

The Bagaduce River watershed is a key wildlife corridor for these species, as well as a provider of healthy and diverse economic resources for humans such as harboring natural nurseries for juvenile fish and shellfish, wildlife viewing, and acting as a natural storm surge buffer (BwH, 2012).



Map 4. Maine Tidal Power Initiative's Site Resource Assessment Published Habitat Map of Significant Wildlife and Essential Habitats. The red circle indicates the location of the VoltturnUS floating wind turbine.

Across the Bagaduce River and due south of Castine on the Cape Rosier peninsula lies the Holbrook Island Sanctuary. The sanctuary encompasses 1,230 acres of forests, fields, marshes, ponds, mudflats, and high-value wetland habitat. The Sanctuary is managed by the State of Maine under the Bureau of Parks and Lands, encouraging visitors to hike the trails and enjoy the abundant mammals and birds that frequent the park. A "Checklist of the



Birds” for Holbrook Island Sanctuary is available to help birders identify the timing and abundance of the avian species known to utilize this habitat (Holbrook Island Sanctuary, 2001). Out of the 223 birds listed in this checklist, 26 were observed in this survey; 10 of the observed species are also listed as “known to breed in the sanctuary.”

Although both the Bagaduce River watershed and the Holbrook Island Sanctuary are not directly in the area of the Castine Harbor Dice Head Test Turbine Site, the wildlife that use these habitats may, at some point, find contact with the turbine’s location. Due to the siting of the VoltturnUS 1/8<sup>th</sup> commercial scale floating platform near the mouth of the Bagaduce River, these hundreds of species known to use the Sanctuary and Bagaduce River’s habitats may follow the river on their way to Penobscot Bay and the pass by the test turbine’s location. For this reason, it is essential to keep in mind the ecological habitats within the vicinity of the Castine Harbor Dice Head Test Site and the avian species that are known to use its resources.

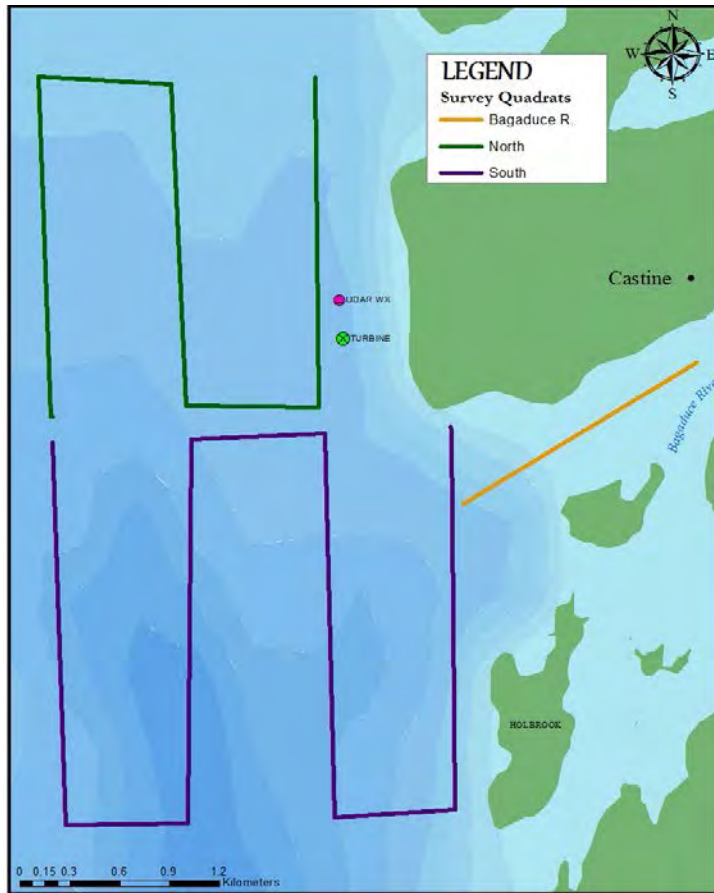
#### **IV. METHODS**

Visual boat-based observations were conducted at the Castine Harbor Dice Head Test Site from August to December of 2013. The survey vessels and captains were provided by Maine Maritime Academy, also located in Castine, Maine. Exact location of the comprehensive survey area was chosen to best cover the wildlife use of the Bagaduce River’s outlet and the area near Dice Head, at the western and southern edge of Castine’s peninsula, as seen previously in Map 1. No control or test area was designated, such as in the protocol used for the Monhegan Offshore Wind Turbine test site (Kennedy & Holberton, 2012); however two quadrats were surveyed using a similar experimental design.

The “north” quadrat covers the region to the west of the Castine peninsula, which is near Dice’s Head, and the “south” quadrat is adjacent to and south of the “north” quadrat, but also covering more of the river’s outlet and due west of Nautilus Island and the northern part of Holbrook Island (Map 5). A third single transect strip includes a single one-mile strip up from the river’s mouth. This was due to abundant bird activity and their use of the Bagaduce River’s “Significant Wildlife Habitat,” as noted under Focus Areas of Statewide Ecological Significance (BwH, 2012). The exact location of the 1/8<sup>th</sup> scale VoltturnUS test turbine on a floating platform is found within an existing cable way (as seen in Map 2) that lies within the area covered by the north quadrat’s coverage zone, between the 3<sup>rd</sup> strip of the transect and the Dice Head landmass.

To prevent confusion, the distinction of “Castine Test Site” refers to the entire surveyed area, and the smaller individual quadrats that lie within this larger area will be hereafter called the “north” or “N,” “south” or “S,” and “Bagaduce River” or “BR” sites, or

quadrats. The complete Castine Test Site covers roughly six square miles (15.64 km<sup>2</sup>) with the boat traveling a linear track totaling 13.4mi (21.5km) that includes both quadrats and



the river portion. All surveys were assessed equally while using the corresponding total survey areas of the south, north, and Bagaduce River quadrats for the analysis of the species composition, location, and behaviors observed within the Castine Test Site.

Map 5. Location of the survey quadrats used in the Castine Harbor Dice Head Test Site with UMaine’s VoltturnUS 1/8<sup>th</sup> scale floating turbine and Lidar Weather Station.

The north quadrat measures 1.3mi by one mile (3.4km<sup>2</sup>), the south quadrat measures 1.6mi x 1.5mi (6.2km<sup>2</sup>), and the Bagaduce River strip measures one mile long (1.6km). Surveys were performed with the vessel running at an average speed of 8.5 knots (15.7 k/h) in a N-S direction, or from the mouth of the Bagaduce River and heading upstream. Each day’s survey began at the starting waypoint in the south quadrat’s north-east corner. All birds, mammals, and other wildlife were documented when observed out to a distance of 500 m on both sides of the boat. After arriving at the next waypoint, surveying would stop and the boat would turn 90° along an E-W line and motor to the next waypoint. Once positioned on the starting point of the second transect strip, the vessel would turn again 90° and surveying would resume, heading in the N-S direction. This pattern was repeated to create four survey strips within the south quadrat (always performed first), followed by a short gap of 0.2 miles and then performing three survey strips, as previously described, to finish the north quadrat. Immediately following the north quadrat, surveying stopped until the vessel reached the starting point for the Bagaduce River’s transect.

Surveys were conducted initially aboard Maine Maritime Academy’s research vessel the *Spicus*, a 34-ft lobster hull/pleasure boat, driven by Captain Erin Bostrom. Beginning as of October 23<sup>rd</sup> and to the end of this session, the M/V Quickwater was then used; a 41ft utility vessel. Observations were conducted from either the bow or stern, depending on sea conditions and safety concerns for that particular day, using binoculars and unaided vision. Height from which observations were made averaged 1.8-2.5 m above sea level. All data were recorded into an RCA digital voice recorder, synchronized with time on a Garmin GPS unit that simultaneously logged the boat’s tracks and waypoints at the beginning and end of each transect line.

Codes used to document species behaviors and other observation and weather conditions followed Gould & Forsell (1989) and Tasker et al. (1984). Examples of common bird behaviors include but are not limited the behaviors provided in Table 1. See Appendix 1 for a complete list of behaviors. Other information includes flight height, estimated using the eye, and recorded in single meters when under a height of five meters or otherwise compartmentalized into five-meter "bins" (10, 15, 20, 25, etc.) up to 50 m. Observations were documented as “> 50 m” for all those above 50 m. The number of birds, species, gender and age (if known), and flight direction (see details below) were recorded. The data were transcribed into Excel and mapped with ArcMap 10.2 software.

Table 1. Example of most common codes used to document behaviors observed during transects (Gould & Forsell, 1989).

Bird Behavior
1 = Sitting on water
20 = Flying in direct and consistent heading
32 = Flying, following ship
34 = Flying, being pirated
35 = Flying, milling or circling (foraging)
48 = Flying, meandering
61 = Feeding at or near surface while flying (dipping or pattering)
65 = Feeding at or near surface, not diving or flying (surface scavenging)
82 = Feeding above surface (pirating)

Some of the most common behaviors documented have lengthy definitions; therefore a shortened descriptive behavior term is used in the following sections. These include the following codes: **#20**, described as “flying in a direct and consistent heading” but hereafter shortened to “direct flight”; **#35**, described as “flying, milling or circling” which typically involves flight associated with foraging behavior and is erratic in height and location, hereafter called “milling”; **#48**, described as “flying, meandering” which involves indirect flight that changes direction but not necessarily height, hereafter called “meandering”; **#61**, described as “feeding at or near the surface while flying (dipping or pattering)” which typically describes scavenging or the act of picking food from the water’s surface, hereafter called “pattering”; and **#65**, described as “feeding at or near surface, not

diving or flying (surface scavenging)” which differs from dipping in that the bird is sitting in the water while foraging, hereafter called “scavenging.”

Four-letter species “alpha” codes may be used in the following tables to simplify table content (see Table 3 for species codes and common names and Appendix 1 also provides scientific names). Flight directions, given in cardinal direction such as NE, SW, WNW, represent the direction in which the bird was flying at the time of observation.

## IV. RESULTS

Seventeen survey days were conducted from August through December 2013. The total area covered on each survey day, which includes the 500m incorporated to each side of the transect strip, measured 8.24km<sup>2</sup> in the south quadrat, 5.8km<sup>2</sup> in the north quadrat, and 1.6km<sup>2</sup> in the Bagaduce River’s transect, for a grand total of 15.64km<sup>2</sup>. Only one survey date, December 20<sup>th</sup>, has a reduced total area covered due to equipment malfunction that prevented a portion of the north quadrat to be recorded. Details pertaining to this date are described during that day’s summary, below.

Table 2 provides the breakdown of the surveys by time of day, sea, and weather conditions during this period of time. Seven of the 17 days surveyed found the turbine blades spinning, which are noted also in Table 2. This state of motion is noted only for the period of time in which the survey was conducted.

Table 2. Survey date, period, and weather conditions.

DATES	DAY PERIOD		SEA CONDITION				Turbine Spinning?
	AM	PM	Sea Height (ft)	Wind Dir	Wind (kt)	Sky	
AUG 7		X	1-2	S	10	Clear	Y
AUG 14	X		FLAT – 0.5	SW	1-3	Fog/Rain to Overcast	N
AUG 21		X	1	S	5	Clear	Y
AUG 28	X		RIPPLE- 0.5	SE	5	Overcast	N
SEPT 4		X	1.5 - 2	SW	10-12	Clear	Y
SEPT 11		X	0.25 - 1	SW	10	Overcast/Partly foggy	N
SEPT 18	X		FLAT - RIPPLE	W	2	Clear	N
OCT 2		X	2 to 2.5	NW	12-15	Clear	N
OCT 9	X		RIPPLE	NNW	2-5	Clear	N
OCT 16		X	RIPPLE – 0.5	SSW	3	Overcast to Rain	N
OCT 23	X		FLAT - RIPPLE	W	1	Clear	N
Oct 30		X	FLAT		1	Clear	N
NOV 4	X		1 - 2	N	10	Clear	Y
NOV 13		X	2-3	NW	10-15	Clear	Y
DEC 3		X	2	N	10	Overcast	Y
DEC 9	X		1	E	8	Overcast to Snow	Y
DEC 20	X		RIPPLE – 0.5	E	4	Overcast	N

Table 3. All observed species with code, densities, and quadrat during August through December 2013.

Species	Common name	Grand Total	SPP Total /km <sup>2</sup>	NORTH	North /km <sup>2</sup>	Common Behavior	SOUTH	South /km <sup>2</sup>	Common Behavior	BR	BR/ km <sup>2</sup>	Common Behavior
COLO	common loon	59	0.383	14	0.146	sitting	22	0.158	sitting	23	0.846	sitting
RTLO	red-throated loon	10	0.026	2	0.020	sitting/direct flight	8	0.057	direct flight			
COEI	common eider	193	2.250	3	0.030	direct flight	9	0.065	direct flight	181	6.654	sitting
SUSC	surf scoter	15	0.036				15	0.108	direct flight			
WWSC	white-winged scoter	37	0.276				18	0.129	direct flight	19	0.699	direct flight
UNSC	unidentified scoter	11	0.033	7	0.071	sitting	4	0.029	direct flight			
HOGGR	horned grebe	10	0.034	10	0.101	sitting						
RNGR	red-necked grebe	17	0.045	4	0.041	sitting	13	0.093	direct flight			
BUFF	bufflehead	4	0.049							4	0.147	sitting
LTDU	long-tailed duck	80	0.312	38	0.397	direct flight	34	0.244	sitting	8	0.294	direct flight
MALL	mallard	18	0.221							18	0.662	sitting
COME	common merganser	1	0.003	1	0.010	direct flight						
RBME	red-breasted merganser	3	0.007				3	0.022	sitting			
UNDU	unidentified duck	17	0.080	11	0.139	sitting	4	0.029	direct flight	2	0.074	sitting/direct flight
GBHE	great blue heron	1	0.002				1	0.007	direct flight			
GBBG	great black-backed gull	1	0.003	1	0.010	scavenging						
HERG	herring gull	350	1.863	104	1.101	sitting	154	1.105	sitting	92	3.382	milling
LAGU	laughing gull	10	0.038	4	0.041	milling	5	0.036	direct flight	1	0.037	direct flight
BLKI	black-legged kittiwake	7	0.020	3	0.030	milling	4	0.029	milling			
BOGU	Bonaparte's gull	394	2.071	90	0.924	sitting	199	1.428	sitting	105	3.860	sitting
RBGU	ring-billed gull	227	1.174	60	0.609	sitting	109	0.782	sitting	58	2.132	sitting
COTE	common tern	6	0.015	1	0.010	milling	5	0.036	direct flight			
UNTE	unidentified tern	15	0.042	6	0.061	scavenging	9	0.065	direct flight			
BLGU	black guillemot	248	2.372	14	0.142	sitting	55	0.395	sitting	179	6.581	sitting
RAZO	razorbill	7	0.017				7	0.050	sitting			
UNAL	unidentified alcid	7	0.029	6	0.080	pursuit diving	1	0.007	sitting			
SHORE	shorebird unidentified	6	0.016	2	0.020	direct flight	4	0.029	direct flight			
AMCR	American crow	20	0.138	11	0.112	direct flight	1	0.007	direct flight	8	0.294	direct flight
CORA	common raven	1	0.002				1	0.007	meandering			
DCCO	double-crested cormorant	47	0.334	5	0.051	direct flight	20	0.143	direct flight	22	0.809	sitting on a rock
BAEA	bald eagle	3	0.007				3	0.022	milling			
OSPR	osprey	3	0.008	1	0.010	milling	2	0.014	direct flight/milling			
UNHA	unidentified hawk	10	0.104	1	0.010	direct flight	1	0.007	direct flight	8	0.294	meandering
TUVU	turkey vulture	1	0.002				1	0.007	direct flight			
HSeal	harbor seal	47	0.180	18	0.183		24	0.172		5	0.184	
Gseal	gray seal	2	0.005				2	0.014				
HAPO	harbor porpoise	63	0.164	13	0.132		50	0.359				

Table 3 provides all species densities and in which quadrat, with the four-letter species code and common names for reference and also providing most frequent behavior of that species. For a more detailed table, Appendix 2 provides abundances and dates on which each species were recorded, including scientific names. Among the 30 bird species identified, which included 1,839 individual birds counted, only one definite State Threatened (MESA) species was observed and included a total of seven razorbills (*Alca torda*; RAZO). However, additional birds were observed that were unable to be specifically identified to the species, but may have included other Federal (FT or FT\*) or State Threatened (StTh or StTh\*), Federal (FE) or State Endangered (StE), or other federal and state-designated conservation status species (BCC or SSC), as seen in Table 4. These will be discussed later in Part V Section D: *Endangered, Threatened, and Birds of Conservation Status*, below. Species that are, or potentially are, FE, FT, StE, or StTh will be marked by red text in the following tables. Also, to simplify terminology, these species will be hereafter lumped into “Species of Conservation Concern,” or SCC, and shall include the identified species as well as the potential SCC species.

Two gray seals (*Halichoerus grypus*), 47 harbor seals (*Phoca vitulina*), and 63 harbor porpoise (*Phocoena phocoena*) were also noted during these surveys, none of which are species of concern.

Table 4. Species of special conservation designation, including potential species.

STATUS	SPECIES
BCC	red-throated loon
BCC	horned grebe
StTh*, SSC*	unidentified duck
SSC	great blue heron
SSC	laughing gull
SSC	Bonaparte's gull
SSC	common tern
FE*, StTh*, BCC*, SSC*	unidentified tern
StTh	razorbill
StTh*, SSC*	unidentified alcid
F*, FT*, StTh/E*, BCC*, SSC*	unidentified shorebird
BCC, SSC	bald eagle

\* indicates potential SCC

The following sections will begin with Part V- Section A, presenting a survey by survey discussion, with tables and maps to outline species, numbers, and locations. Sections B through E will discuss bird behaviors, species of concern, and all other observations. Again, Appendix 2 provides a more detailed table of this data gathered per survey day. Throughout this report, four-letter species “alpha” codes are also used to simplify text and table content.

To further discuss the bird observations during these surveys, bird species will be generally grouped by a taxonomical classification at the Order level. Eight orders within the

Class Aves were observed utilizing this region within the Gulf of Maine during the course of our study. The maps and figures used in this report have been colored using a consistent scheme that groups each of these five Groups by color. Group 1 (eider, scoters, ducks, and loons) is represented by shades of green (hereafter called “Group 1A”), Group 2 (gulls, terns, alcids) have yellows (“Group 2C”), Group 3 (cormorants) is red (“Group 3S”), Group 4 (crows and ravens) is blue (“Group 4P”), and Group 5 (osprey, eagles, turkey vulture, hawk) is brown (“Group 5A”). This color scheme will continue to be used when discussing bird behaviors, foraging species, and birds of conservation concern, as seen below. It does not include marine mammals or other species.

The five Species-Groups are as follows:

<b>-Order Anseriformes</b>	(eider, scoters, and ducks)	<b>GROUP 1</b>
<b>-Order Gaviiformes</b>	(loons)	
<b>-Order Podicepsiformes</b>	(grebes)	
<b>-Order Pelecaniformes</b>	(heron)	
<b>-Order Charadriiformes</b>	(large and small gulls, terns, alcids)	<b>GROUP 2</b>
<b>-Order Suliformes</b>	(cormorant)	<b>GROUP 3</b>
<b>-Order Passeriformes</b>	(corvids)	<b>GROUP 4</b>
<b>-Order Accipiteriformes</b>	(osprey, eagles, turkey vulture, hawk)	<b>GROUP 5</b>

## A. Surveys by Day

**AUGUST 7, 2013**

**AFTERNOON SURVEY (15:37pm)**

Table 5. Numbers of species observed during the afternoon survey of August 7.

SPECIES	N	S	BR	Total
herring gull		2	1	3
laughing gull			1	1
Bonaparte's gull	3		2	5
ring-billed gull		7	3	10
common tern		1		1
unidentified tern		3		3
black guillemot		5	1	6
double-crested cormorant		2	4	6
osprey	1	1		2
harbor porpoise	1			1
<b>Bird Total</b>	<b>4</b>	<b>21</b>	<b>12</b>	<b>37</b>
<b>Birds/km<sup>2</sup></b>	<b>0.7</b>	<b>2.6</b>	<b>7.5</b>	<b>3.6</b>

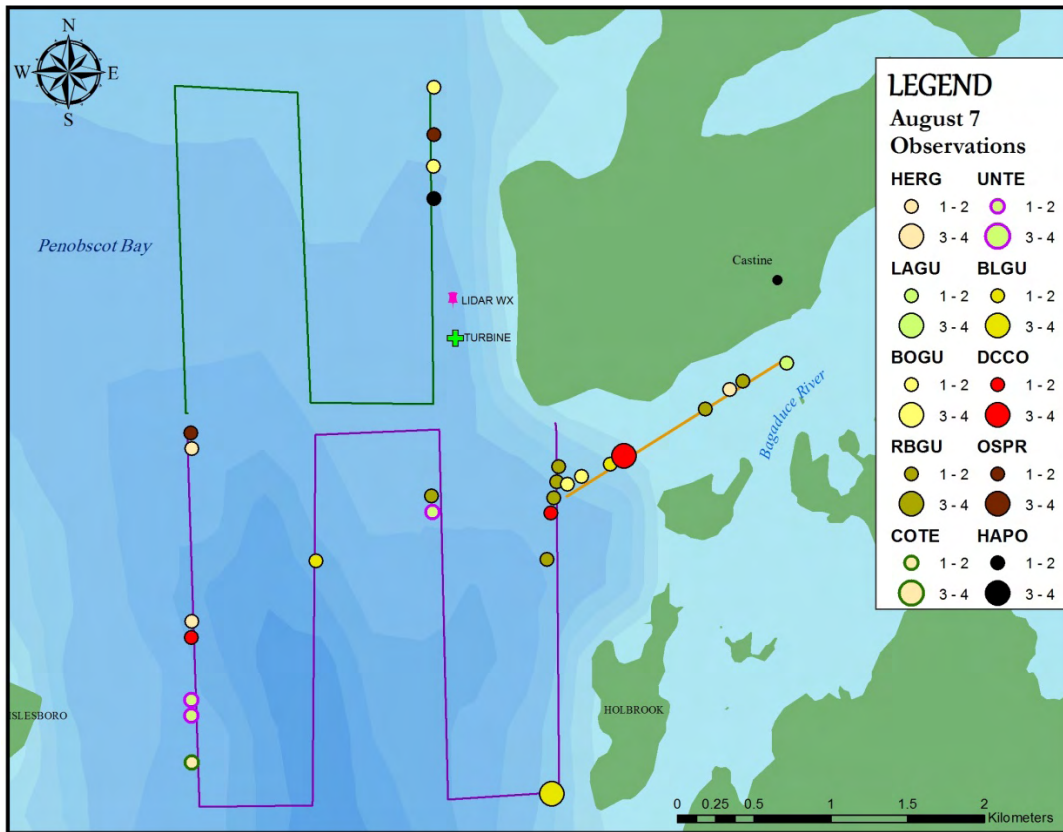
On August 7<sup>th</sup>, conditions were rated as “Excellent” with seas averaging between one to two feet (0.3 to 0.6m), with winds from the south at 10kts and clear sky. The VolturnUS turbine was spinning at the time of the survey. Map 6 shows the general survey tracklines with the location and number of animals recorded. Of the nine total bird species observed on this date, 57% were found in the south quadrat and included seven species, followed by 32% found in the BR, and only 11% in the north. The top three species on this day were BOGU (27%), followed by black guillemot (*Cepphus grille*; BLGU) at 16%, and the double-crested cormorant (*Phalacrocorax auritis*; DCCO) also with 16% (Table 5). Only one harbor porpoise was found in the north quadrat.

Table 6 shows all behaviors by all bird species observed. Thirty-two percent of all birds were observed sitting in the water followed by 29% of birds flying direct. Of all birds, 22% demonstrated a foraging behavior, divided evenly between the north and south quadrats. Of the flying birds, 28% flew at a height of one meter and 22% flew at five meters.

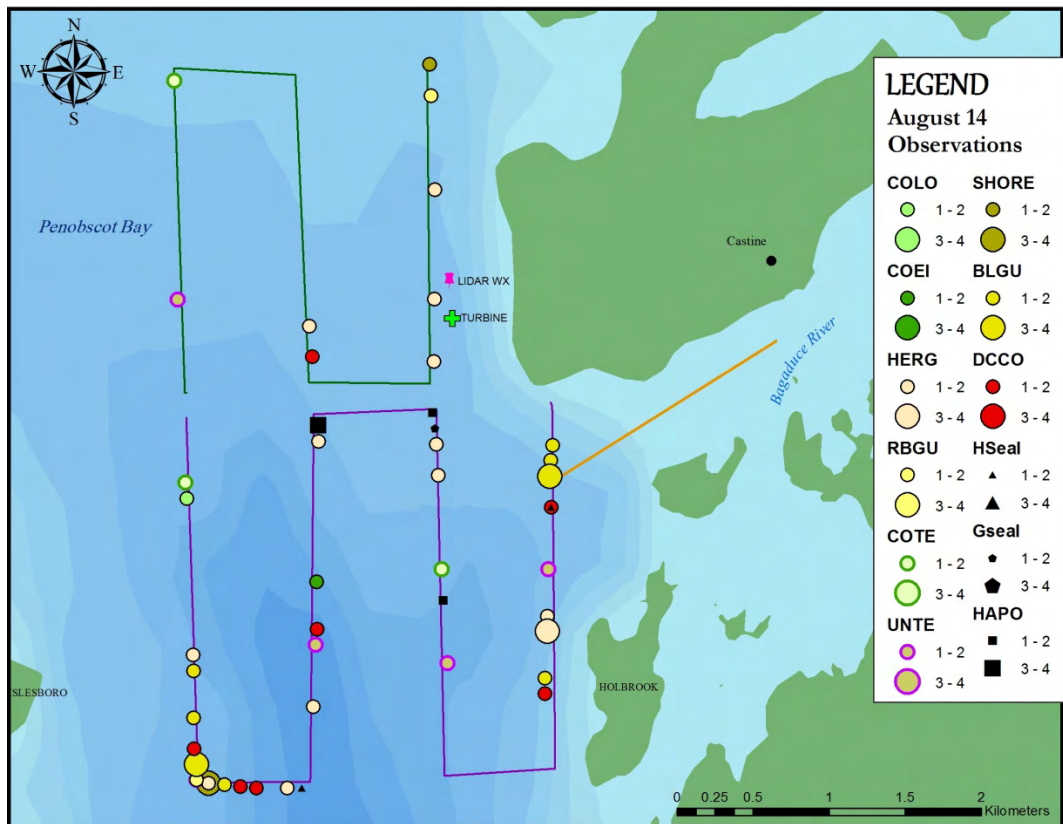
Table 6. Bird species, behavior code, and flight height on August 7.

BEHAVIOR	1		10					20		35		48		61			65	Total
	0	0	1	5	10	20	25	2	20	2	10	1	5	15	5			
HERG	1					1					1					3		
LAGU							1									1		
BOGU	1									1			1	1	1	5		
RBGU	6			2											2	10		
COTE				1												1		
UNTE					1			1				1				3		
BLGU	4		2													6		
DCCO		4	2													6		
OSPR						1			1							2		
<b>Total</b>	<b>12</b>	<b>4</b>	<b>4</b>	<b>3</b>	<b>1</b>	<b>2</b>	<b>1</b>	<b>1</b>	<b>1</b>	<b>1</b>	<b>1</b>	<b>1</b>	<b>1</b>	<b>1</b>	<b>3</b>	<b>37</b>		





Map 6. Observations of wildlife during August 7 survey.



Map 7. Observations of wildlife during August 14 survey.

# AUGUST 14, 2013

# MORNING SURVEY (8:17am)

Table 7. Numbers of species observed during the morning survey of August 14.

SPECIES	N	S	BR	Total
common loon		1		1
common eider		1		1
herring gull	5	8	4	17
ring-billed gull	1		1	2
common tern	1	2		3
unidentified tern	1	4		5
black guillemot		11	8	19
unidentified shorebird	1	4		5
double-crested cormorant	1	3	3	7
harbor seal		2	1	3
gray seal		1		1
harbor porpoise		7		7
<b>Bird Total</b>	<b>10</b>	<b>34</b>	<b>16</b>	<b>60</b>
<b>Birds/km<sup>2</sup></b>	<b>1.7</b>	<b>4.1</b>	<b>10</b>	<b>5.3</b>

On August 14<sup>th</sup>, conditions were rated as “Maximum” however degressed to a rainstorm that caused conditions to degrade to “Average.” By the third strip of the north transect, the rain ceased and conditions returned to “Maximum” with no fog. Seas averaged between flat calm to a half foot (0 to 0.15m), with winds from the SW at one to three knots. The VoltturnUS turbine was not spinning at the time of the survey. Map 7 shows the general survey tracklines with the location and number of animals recorded. Of the eight total bird species observed on this date, 57% were found in the south quadrat and included eight species, followed by 27% found in the BR, and 17% in the north. The top three species on this day were the BLGU (32%), followed by herring gulls (*Larus argentatus*; HERG) at 28%, and DCCO with 12% (Table 7). Only one harbor seal was observed in the BR, whereas only in the south quadrat were two harbor seals, one gray seal, and a total of seven harbor porpoise observed.

Table 8 shows all behaviors by all bird species observed. Forty-seven percent of all birds were observed flying direct followed by 32% of birds sitting in the water. Of all birds, 13% demonstrated a foraging behavior; 63% of the foraging occurred in the south quadrat. Of the flying birds, 38% flew at a height of one meter and 22% flew at five meters.

Table 8. Bird species, behavior code, and flight height on August 14.

BEHAVIOR	1	10	20							32	35			48		65	Total
HEIGHT (m)	0	0	1	5	10	15	20	25	30	5	1	5	10	10	20	0	
COLO	1																1
COEI			1														1
HERG	3		2	4	2	1			1		3				1		17
RBGU			1							1							2
COTE				1		1						1					3
UNTE					1		1					1		1		1	5
BLGU	15		3													1	19
SHORE								5									5
DCCO		2	4										1				7
<b>Grand Total</b>	<b>19</b>	<b>2</b>	<b>11</b>	<b>5</b>	<b>3</b>	<b>2</b>	<b>1</b>	<b>5</b>	<b>1</b>	<b>1</b>	<b>3</b>	<b>2</b>	<b>1</b>	<b>1</b>	<b>1</b>	<b>2</b>	<b>60</b>

# AUGUST 21, 2013

# AFTERNOON SURVEY (12:40pm)

Table 9. Numbers of species observed during the afternoon survey of August 21.

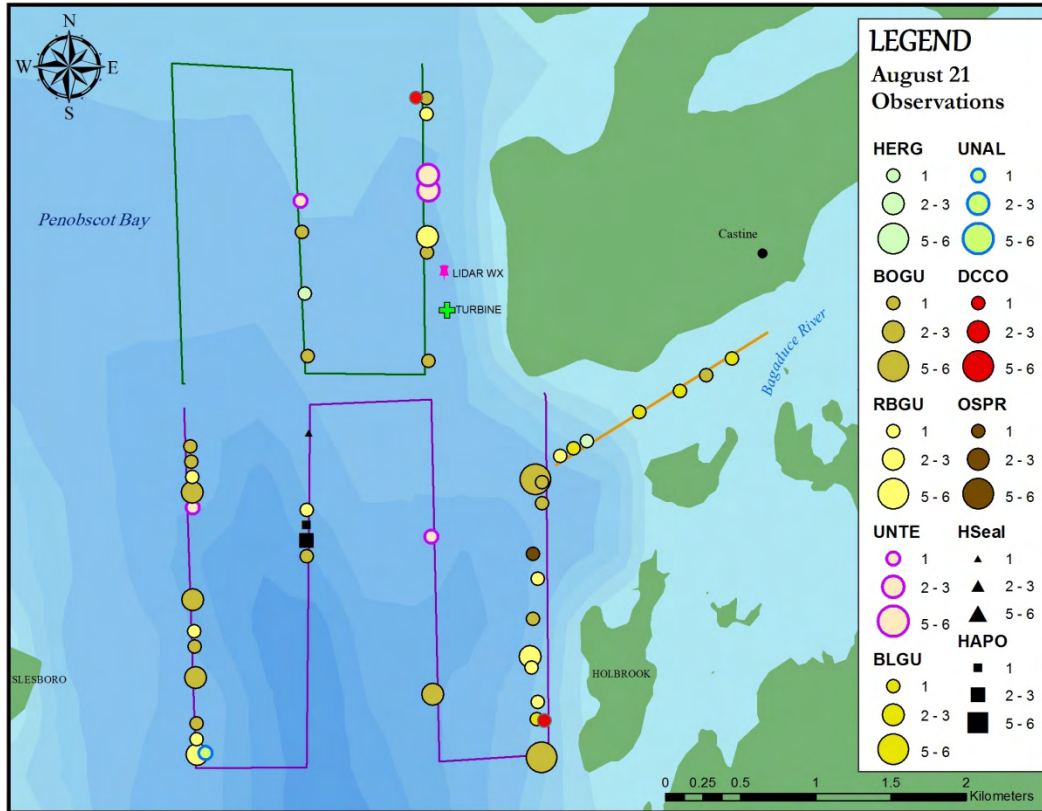
SPECIES	N	S	BR	Total
herring gull	1		1	2
Bonaparte's gull	6	27	1	34
ring-billed gull	3	17	2	22
unidentified tern	5	2		7
black guillemot		1	4	5
unidentified alcid		1		1
double-crested cormorant	1	1		2
osprey		1		1
harbor seal		1		1
harbor porpoise		3		3
<b>Bird Total</b>	<b>16</b>	<b>50</b>	<b>8</b>	<b>74</b>
<b>Birds/km<sup>2</sup></b>	<b>2.8</b>	<b>6.1</b>	<b>5</b>	<b>4.6</b>

On August 21<sup>st</sup>, conditions were rated as “Maximum” with seas averaging one foot (0.3m), with winds from the south at five knots and a clear sky. The VolturnUS turbine was spinning at the time of the survey. Map 8 shows the general survey tracklines with the location and number of animals recorded. Of the seven total bird species identified on this date, 68% were found in the south quadrat and included six species, followed by 22% found in the north quadrat, and only 11% in the BR. The top three species on this day were the BOGU, 46%, followed by ring-billed gull (*L. delawarensis*; RBGU) at 30%, and an additional 9.4% of unidentified gulls (Table 9). Only one harbor seal and three harbor porpoise were found in the south quadrat.

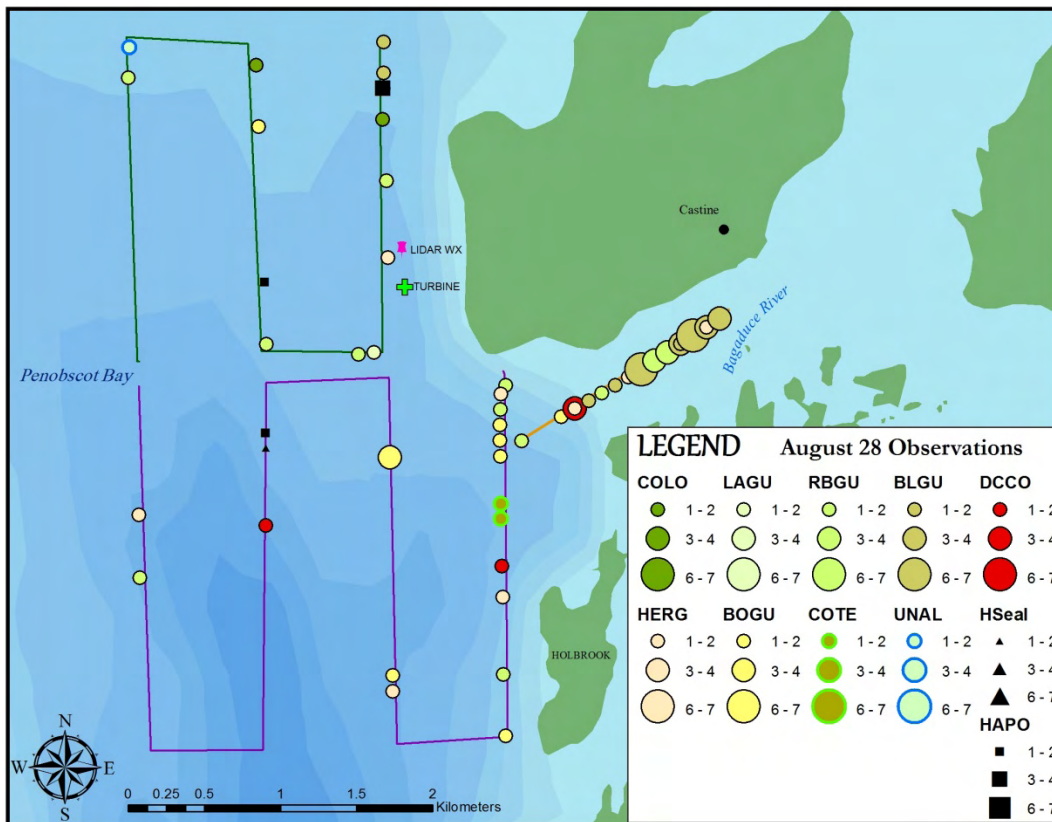
Table 10 shows all behaviors by all bird species observed. Fifty-three percent of all birds were observed sitting in the water, followed by 23% of birds scavenging while sitting, and 19% were flying direct. Of all birds, 26% demonstrated a foraging behavior, with 68% occurring in the south quadrat, 26% in the north, and only one bird milling in the BR. Of the flying birds, 50% flew at a height of five meters, and 22% flew at one meter.

Table 10. Bird species, behavior code, and flight height on August 21.

BEHAVIOR	1	20				35		48	65		Total
HEIGHT (m)	0	1	5	10	15	5	15	1	0	5	
HERG				1	1						2
BOGU	20		3						10	1	34
RBGU	13		3	1		1		2	2		22
UNTE			2	1						4	7
BLGU	5										5
UNAL	1										1
DCCO		2									2
OSPR							1				1
<b>Grand Total</b>	<b>39</b>	<b>2</b>	<b>8</b>	<b>3</b>	<b>1</b>	<b>1</b>	<b>1</b>	<b>2</b>	<b>12</b>	<b>5</b>	<b>74</b>



Map 8. Observations of wildlife during August 21 survey.



Map 9. Observations of wildlife during August 28 survey.

# AUGUST 28, 2013

# MORNING SURVEY (8:15am)

Table 11. Numbers of species observed during the morning survey of August 28.

SPECIES	N	S	BR	Total
common loon	2			2
herring gull	1	6	5	12
laughing gull	1			1
Bonaparte's gull	1	11	2	14
ring-billed gull	4	8	15	27
common tern		2		2
black guillemot	4		35	39
unidentified alcid	1			1
double-crested cormorant		2	4	6
harbor seal		1	1	2
harbor porpoise	5	1		6
<b>Bird Total</b>	<b>14</b>	<b>29</b>	<b>61</b>	<b>104</b>
<b>Birds/km<sup>2</sup></b>	<b>2.4</b>	<b>3.5</b>	<b>38.1</b>	<b>14.7</b>

On August 28<sup>th</sup>, conditions were rated as “Maximum” with seas averaging from a ripple to a half foot (0.01 to 0.3m), with winds from the SE at five knots and an overcast sky. The VoltturnUS turbine was not spinning at the time of the survey. Map 9 shows the general survey tracklines with the location and number of animals recorded. Of the nine total bird species observed on this date, 59% were found in the BR but only included five species, followed by 28% found in the south quadrat, and 13% in the north. The top three species on this day were the BLGU with 38%, followed by RBGU at 26%, and BOGU with 13% (Table 11). Only one harbor seal was observed in the BR, whereas in the south quadrat one harbor seal and one harbor porpoise was observed, and a total of five harbor porpoise were observed in the north quadrat.

Table 12 shows all behaviors by all bird species observed. Fifty-nine percent of all birds were observed sitting in the water, followed by 17% of birds scavenging while sitting, and 12% flew direct. Of all birds, 25% demonstrated a foraging behavior; 62% of the foraging occurred in the south quadrat, followed by 31% in the BR, and only two birds in the north. Of the flying birds, 45% flew at a height of five meters, and 30% flew at 10m.

Table 12. Bird species, behavior code, and flight height on August 28.

BEHAVIOR	1	10	20					35		65	Total
HEIGHT (m)	0	0	1	2	5	10	15	5	10	0	
COLO	2										2
HERG	3	1			3	1		2	1	1	12
LAGU			1								1
BOGU	2									12	14
RBGU	14			1	1	2	1	3		5	27
COTE									2		2
BLGU	39										39
UNAL	1										1
DCCO		4	2								6
<b>Grand Total</b>	<b>61</b>	<b>5</b>	<b>2</b>	<b>2</b>	<b>4</b>	<b>3</b>	<b>1</b>	<b>5</b>	<b>3</b>	<b>18</b>	<b>104</b>

# SEPTEMBER 4, 2013

# AFTERNOON SURVEY (15:10pm)

Table 13. Numbers of species observed during the afternoon survey of September 4.

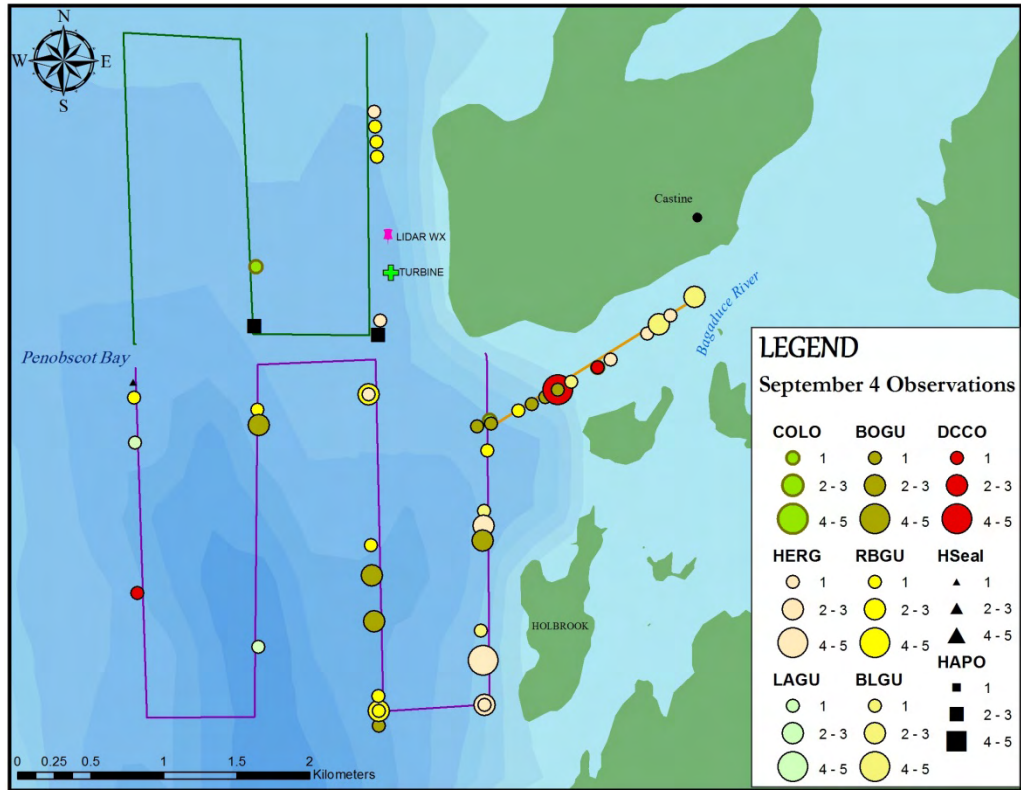
SPECIES	N	S	BR	Total
common loon	1	1	1	3
herring gull	3	14	3	20
laughing gull		5		5
Bonaparte's gull		11	8	19
ring-billed gull	3	10	1	14
black guillemot		2	7	9
double-crested cormorant		1	5	6
harbor seal		1		1
harbor porpoise	5			5
<b>Bird Total</b>	<b>7</b>	<b>44</b>	<b>25</b>	<b>76</b>
<b>Birds/km<sup>2</sup></b>	<b>1.2</b>	<b>5.4</b>	<b>15.6</b>	<b>7.4</b>

On September 4<sup>th</sup>, conditions were rated as “Excellent” with seas averaging 1.5 to two feet (0.45 – 0.6m), with winds from the SW at 10-12 knots and a clear sky. The VoltturnUS turbine was spinning at the time of the survey. Map 10 shows the general survey tracklines with the location and number of animals recorded. Of the seven total bird species identified on this date, 58% were found in the south quadrat and included all seven species, followed by 33% found in the BR. The top three species on this day were the HERG (26%), followed by BOGU at 25%, and 18% were RBGU (Table 13). Only one harbor seal was observed in the south quadrat and a total of five harbor porpoise were found in the north quadrat.

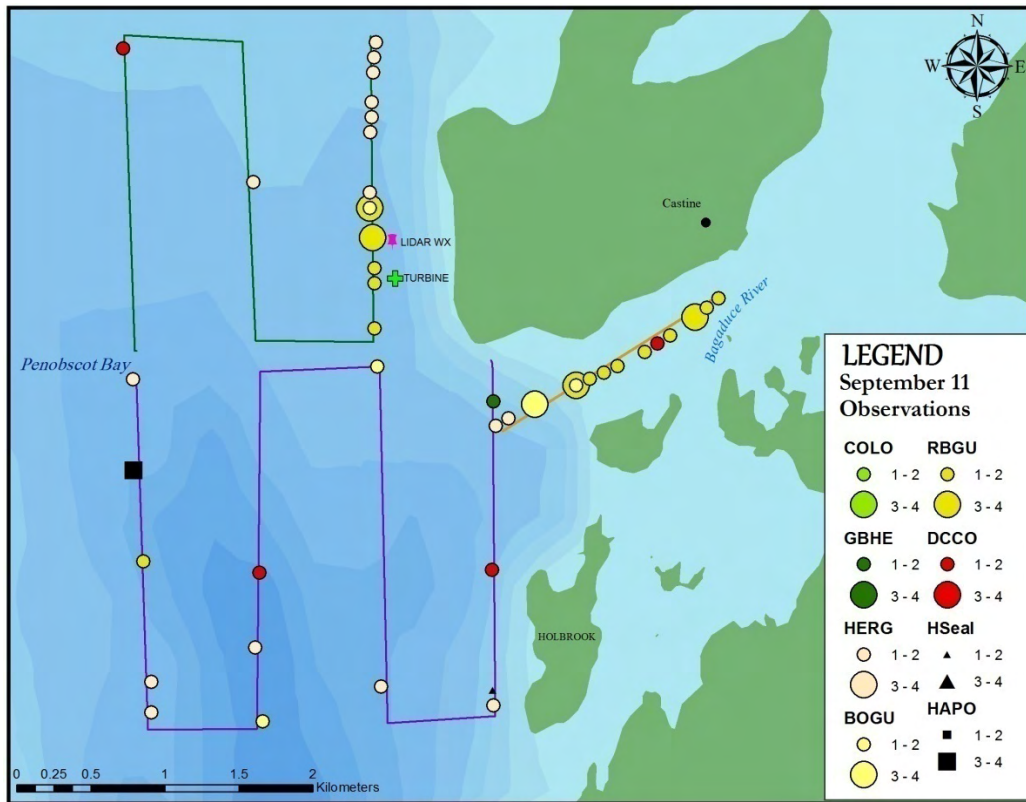
Table 14 shows all behaviors by all bird species observed. Thirty-nine percent of birds were sitting in the water, followed by 30% flying direct, and 16% scavenged while sitting. Of all birds, 20% demonstrated a foraging behavior, with 53% occurring in the south quadrat, 33% in the BR, and only two birds scavenged while sitting in the north quadrat. Of the flying birds, 40% flew at a height of one meter, and 30% flew at five meters.

Table 14. Bird species, behavior code, and flight height on September 4.

BEHAVIOR	1	10	20					32	35	48		61	65		Total
HEIGHT (m)	0	0	1	5	10	15	25	<5	5	2	15	5	0	3	
COLO	3														3
HERG	1		9	3	2	1		1		2			1		20
LAGU	1			1			1		1			1			5
BOGU	13			1					1				2	2	19
RBGU	3		1	1			1			1			7		14
BLGU	9														9
DCCO		4	2												6
<b>Grand Total</b>	<b>30</b>	<b>4</b>	<b>12</b>	<b>6</b>	<b>2</b>	<b>1</b>	<b>2</b>	<b>1</b>	<b>2</b>	<b>1</b>	<b>2</b>	<b>1</b>	<b>10</b>	<b>2</b>	<b>76</b>



Map 10. Observations of wildlife during September 4 survey.



Map 11. Observations of wildlife during September 11 survey.

**SEPTEMBER 11, 2013**

**AFTERNOON SURVEY (15:10pm)**

Table 15. Numbers of species observed during the afternoon survey of September 11.

SPECIES	N	S	BR	Total
common loon			1	1
great blue heron		1		1
herring gull	10	6	6	22
Bonaparte’s gull	1	3	5	9
ring-billed gull	11	1	24	36
double-crested cormorant	1	2	1	4
harbor seal		1		1
harbor porpoise		3		3
<b>Bird Total</b>	<b>23</b>	<b>13</b>	<b>37</b>	<b>73</b>
<b>Birds/km<sup>2</sup></b>	<b>4.0</b>	<b>1.6</b>	<b>23.1</b>	<b>9.6</b>

On September 11<sup>th</sup>, conditions were rated as “Excellent” with overcast skies but digressed to “Good” due to increased fog. Seas averaged one-quarter to one foot (0.07 – 0.3m), with winds from the SW at 10 knots. The VoltturnUS turbine was not spinning at the time of the survey. Map 11 shows the general survey tracklines with the location and number of animals recorded. Of the six total bird species identified on this date, 51% were found in the BR and included six species, followed by 32% found in the north quadrat. The top three species on this day were the RBGU (39%), followed by HERG at 30%, and 12% were BOGU (Table 15). Only one harbor seal and three harbor porpoise were observed in the south quadrat.

Table 16 shows all behaviors by all bird species observed. Forty percent of all birds were observed sitting in the water, followed by 29% of birds scavenging while sitting, and 21% flew direct. Of all birds, 37% demonstrated a foraging behavior, with 48% occurring in both the north and BR quadrats, and only one BOGU pattered in the south quadrat. Of the flying birds, 52% flew at a height of one meter, and 39% flew at five meters.

Table 16. Bird species, behavior code, and flight height on September 11.

BEHAVIOR	1	20				35		48		61	65	Total
HEIGHT (m)	0	1	5	20	35	1	5	1	5	5	0	
COLO	1											1
GBHE					1							1
HERG	12	1	1	1				1	1			22
BOGU			2			3				1		9
RBGU	15	3	3			1	1					36
DCCO	1	3										4
<b>Grand Total</b>	<b>29</b>	<b>7</b>	<b>6</b>	<b>1</b>	<b>1</b>	<b>4</b>	<b>1</b>	<b>1</b>	<b>1</b>	<b>1</b>	<b>21</b>	<b>73</b>



# SEPTEMBER 18, 2013

# MORNING SURVEY (8:58am)

Table 17. Numbers of species observed during the morning survey of September 18.

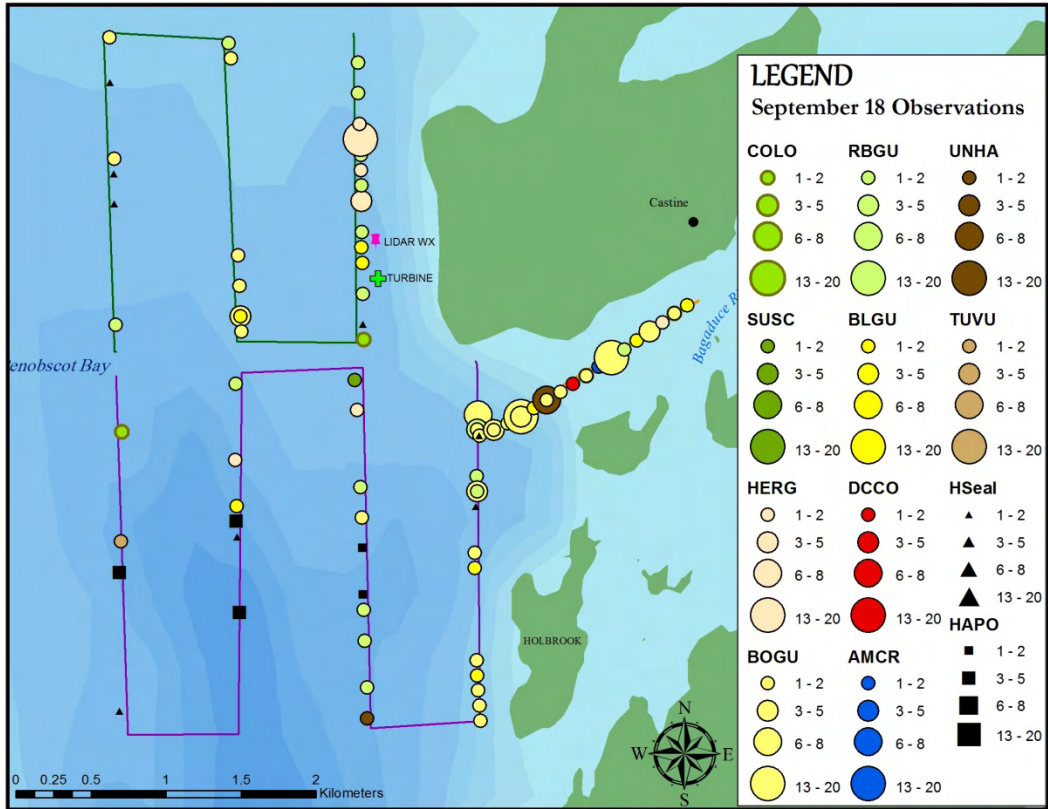
SPECIES	N	S	BR	Total
common loon	1	1	2	4
surf scoter		2		2
herring gull	21	4	1	26
Bonaparte's gull	16	21	54	91
ring-billed gull	14	14	2	30
black guillemot	4	7	5	16
American crow			2	2
double-crested cormorant			1	1
hawk unidentified		1	8	9
turkey vulture		1		1
harbor seal	5	3	1	9
harbor porpoise		15		15
<b>Bird Total</b>	<b>56</b>	<b>51</b>	<b>75</b>	<b>182</b>
<b>Birds/km<sup>2</sup></b>	<b>9.7</b>	<b>6.2</b>	<b>46.7</b>	<b>20.9</b>

On September 18<sup>th</sup>, conditions were rated as “Maximum” with seas averaging from flat to a ripple (0.01m), with winds from the W at two knots and a clear sky. The VoltturnUS turbine was not spinning at the time of the survey. Map 12 shows the general survey tracklines with the location and number of animals recorded. Of the 10 total bird species observed on this date, 41% were found in the BR and included eight species, followed by 31% found in the north quadrat, and 28% in the south. The top three species on this day were the BOGU with 50%, followed by RBGU at 16%, and HERG with 14% (Table 17). Only one harbor seal was observed in the BR, whereas in the north quadrat five harbor seals were observed, and in the south quadrat three harbor seals and a total of 15 harbor porpoise were observed.

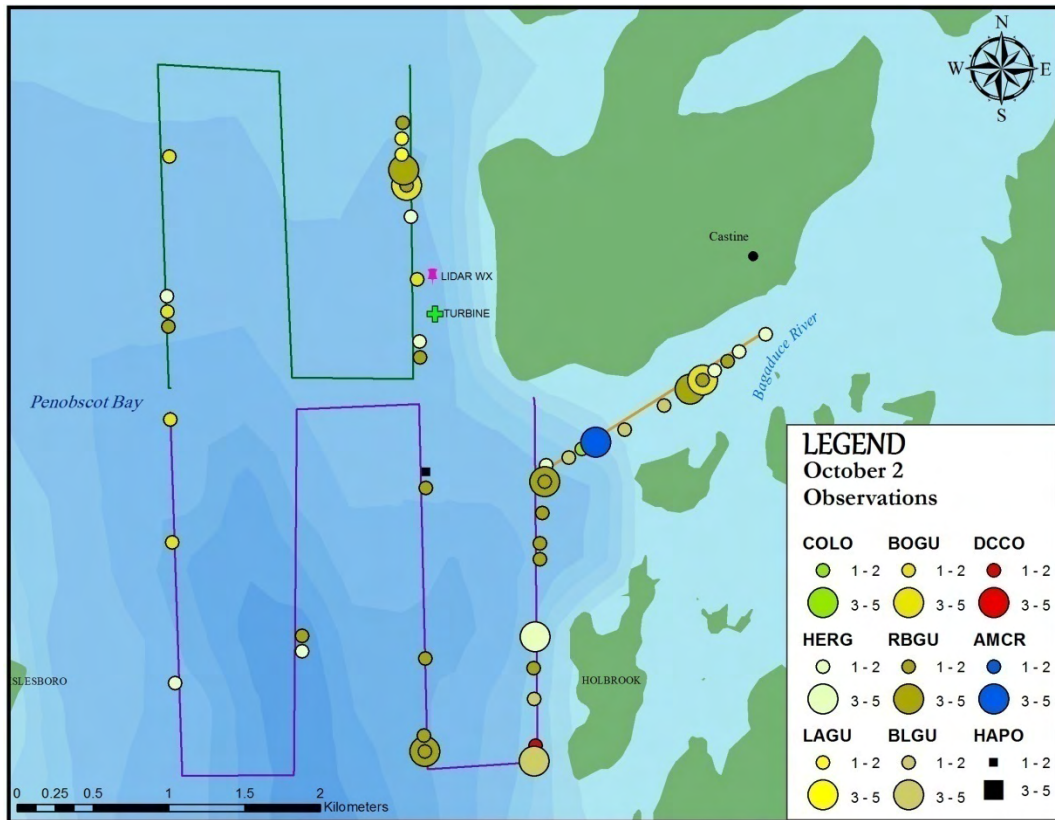
Table 18 shows all behaviors by all bird species observed. Fifty-five percent of all birds were observed sitting in the water, followed by 22% of birds flying direct, and 9.3% milled. Of all birds, 16% demonstrated a foraging behavior; 79% of the foraging occurred in the south quadrat, followed by 17% in the BR, and only one bird scavenged in the north. Of the flying birds, 35% flew at a height of five meters, with 16% flying at three meters, and 16% flying at 10m.

Table 18. Bird species, behavior code, and flight height on September 18.

BEHAVIOR	1	20							35			48			65		70	Total
HEIGHT (m)	0	1	2	5	10	15	20	>50	3	5	25	2	5	50	0	5	0	
COLO	1	1															2	4
SUSC		2																2
HERG	18			4	2	1				1								26
BOGU	60		2	8					11	4		1	3		2			91
RBGU	8	1		4	9	1					1				5	1		30
BLGU	14																2	16
AMCR						2												2
DCCO		1																1
UNHA								1						8				9
TUVU							1											1
<b>Grand Total</b>	<b>101</b>	<b>5</b>	<b>2</b>	<b>16</b>	<b>11</b>	<b>4</b>	<b>1</b>	<b>1</b>	<b>11</b>	<b>5</b>	<b>1</b>	<b>1</b>	<b>3</b>	<b>8</b>	<b>7</b>	<b>1</b>	<b>4</b>	<b>182</b>



Map 12. Observations of wildlife during September 18 survey.



Map 13. Observations of wildlife during October 2 survey.

# OCTOBER 2, 2013

# AFTERNOON SURVEY (15:12pm)

Table 19. Numbers of species observed during the afternoon survey of October 2.

SPECIES	N	S	BR	Total
common loon			1	1
herring gull	5	6	6	17
laughing gull	3			3
Bonaparte's gull	7	3	3	13
ring-billed gull	10	22	6	38
black guillemot		5	6	11
American crow			4	4
double-crested cormorant		1	1	2
harbor porpoise		2		2
<b>Bird Total</b>	<b>25</b>	<b>37</b>	<b>27</b>	<b>89</b>
<b>Birds/km<sup>2</sup></b>	<b>4.3</b>	<b>4.5</b>	<b>16.9</b>	<b>8.6</b>

On October 2<sup>nd</sup>, conditions were rated as “Good” with seas averaging two to 2.5 feet (0.6 – 0.67m), with winds from the NW at 12-15 knots. The VoltturnUS turbine was not spinning at the time of the survey. Map 13 shows the general survey tracklines with the location and number of animals recorded. Of the eight total bird species identified on this date, 42% were found in the south quadrat and included only five species, followed by 30% found in the BR, and 28% in the north quadrat. The top three species on this day were the RBGU (43%), followed by HERG at 19%, and 15% were BOGU (Table 19). Only two harbor seals were observed in the south quadrat.

Table 20 shows all behaviors by all bird species observed. Sixty-one percent of all birds were observed sitting in the water, followed by 16% flying direct. Of all birds, 18% demonstrated a foraging behavior, with 42% occurring in the south quadrat, 30% in the BR, and 28% in the north. Of the flying birds 34% flew at a height of two meters, and 28% flew at one meter.

Table 20. Bird species, behavior code, and flight height on October 2.

BEHAVIOR	1	20					29	35			48		61		65		Total
HEIGHT (m)	0	1	2	5	10	15	<5	1	2	5	2	5	1	2	0	1	
COLO	1																1
HERG	10			1	4						2						17
LAGU									2		1						3
BOGU	11		1							1							13
RBGU	22					1	1	4	1		1		1	1	5	1	38
BLGU	9	2															11
AMCR			4														4
DCCO	1	1															2
<b>Grand Total</b>	<b>54</b>	<b>3</b>	<b>5</b>	<b>1</b>	<b>4</b>	<b>1</b>	<b>1</b>	<b>4</b>	<b>3</b>	<b>1</b>	<b>1</b>	<b>3</b>	<b>1</b>	<b>1</b>	<b>5</b>	<b>1</b>	<b>89</b>

Table 21. Numbers of species observed during the morning survey of October 9.

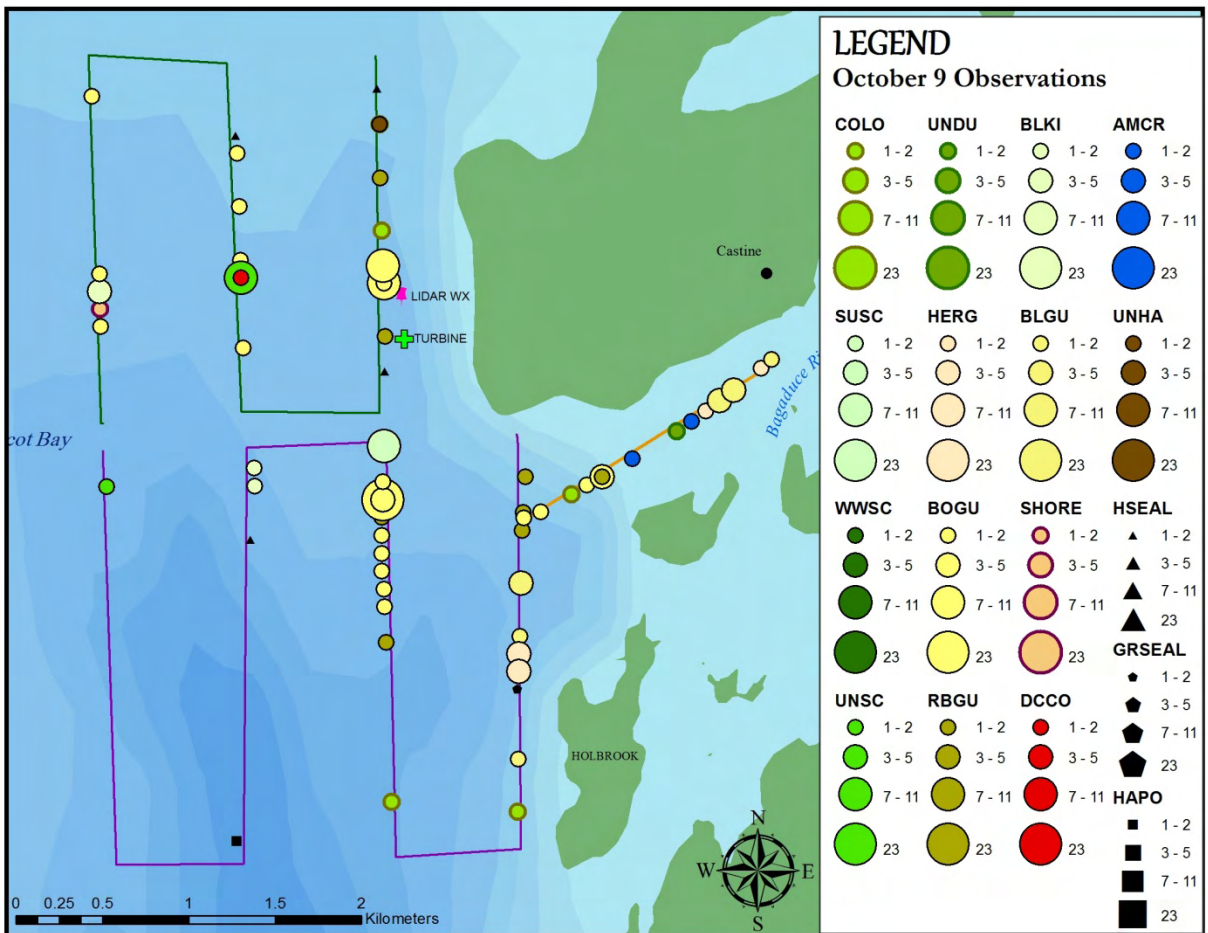
SPECIES	N	S	BR	Total
common loon	2	2	1	5
surf scoter		11		11
white-winged scoter		10		10
scoter unidentified	7	1		8
unidentified duck			1	1
herring gull	1	8	3	12
black-legged kittiwake	3	2		5
Bonaparte's gull	32	43	9	84
ring-billed gull	3	7	1	11
black guillemot		7	15	22
unidentified shorebird	1			1
American crow			2	2
double-crested cormorant	1			1
hawk unidentified	1			1
harbor seal	3	3	1	7
gray seal		1		1
harbor seal		1		1
<b>Bird Total</b>	<b>51</b>	<b>91</b>	<b>32</b>	<b>174</b>
<b>Birds/km<sup>2</sup></b>	<b>8.8</b>	<b>11.1</b>	<b>20.0</b>	<b>13.3</b>

On October 9<sup>th</sup>, conditions were rated as “Maximum” with seas at only a ripple (0.01m), with winds from the NNW at two to five knots and a clear sky. The VoltturnUS turbine was not spinning at the time of the survey. Map 14 shows the general survey tracklines with the location and number of animals recorded. Of the 13 total bird species observed on this date, 52% were found in the south quadrat and included nine species, followed by 29% found in the north quadrat, and 18% in the BR. The top three species on this day were the BOGU with 48%, followed by BLGU at 13%, and HERG with 6.9% (Table 21). Only one harbor seal was observed in the BR, whereas in the north quadrat three harbor seals were observed, and in the south quadrat three harbor seals, one gray seal, and one harbor porpoise was observed.

Table 22 shows all behaviors by all bird species observed. Fifty-five percent of all birds were observed sitting in the water, followed by 22% of birds flying direct, and 9.3% milled. Of all birds, 16% demonstrated a foraging behavior; 79% of the foraging occurred in the south quadrat, followed by 17% in the BR, and only one bird scavenged in the north. Of the flying birds, 69% flew at a height of five meters, and 15% flew at one meter.

Table 22. Bird species, behavior code, and flight height on October 9.

BEHAVIOR	1	20					35				48			61			65	70	Total
HEIGHT (m)	0	1	5	10	15	30	1	2	3	5	1	5	10	1	2	5	0	0	
COLO	3				1		1												5
SUSC			11																11
WWSC			10																10
UNSC		7																	8
UNDU	1																		1
HERG	6	1	1	1						3									12
BLKI			1						4										5
BOGU	64		8					1	2	3						1	2	2	1
RBGU	4	1	2	1								1	1						11
BLGU	21																		22
SHORE		1																	1
AMCR		1	1																2
DCCO	1																		1
UNHA						1												1	1
<b>Grand Total</b>	<b>107</b>	<b>5</b>	<b>34</b>	<b>2</b>	<b>1</b>	<b>1</b>	<b>1</b>	<b>1</b>	<b>2</b>	<b>7</b>	<b>3</b>	<b>1</b>	<b>1</b>	<b>1</b>	<b>2</b>	<b>3</b>	<b>1</b>	<b>1</b>	<b>174</b>



Map 14. Observations of wildlife during October 9 survey.

# OCTOBER 16, 2013

# AFTERNOON SURVEY (14:46pm)

Table 23. Numbers of species observed during the afternoon survey of October 16.

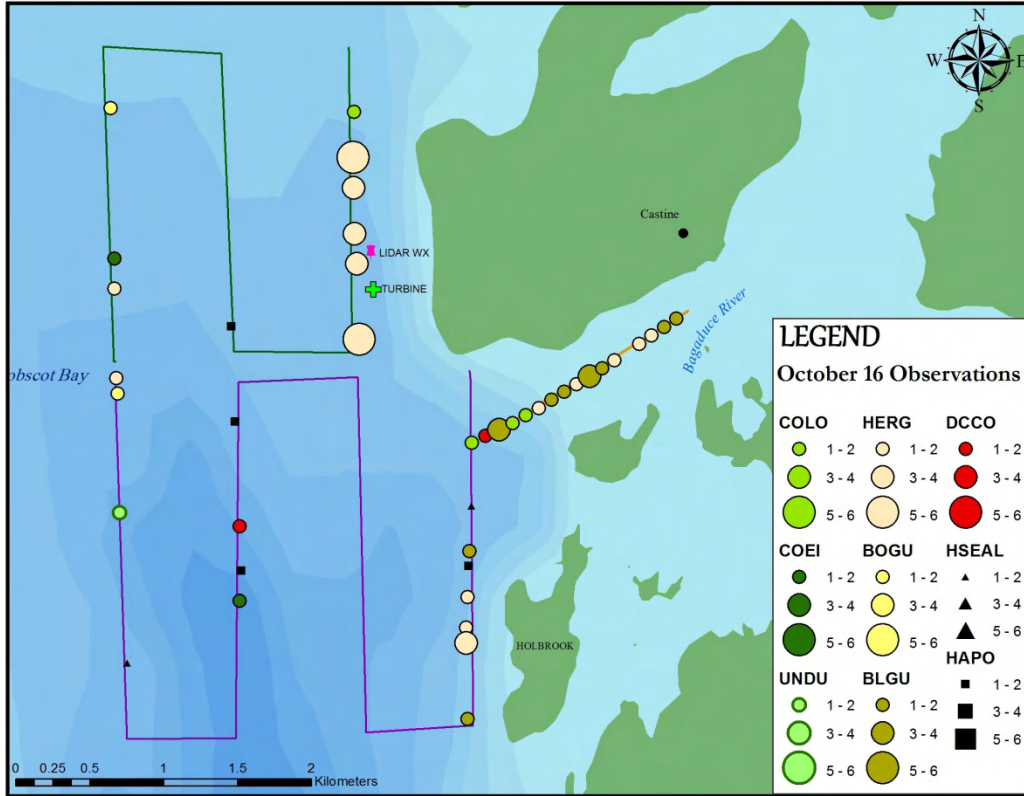
SPECIES	N	S	BR	Total
common loon	1		4	5
common eider	1	1		2
unidentified duck		2		2
herring gull	22	8	10	40
Bonaparte's gull	2	1		3
black guillemot		2	18	20
double-crested cormorant	1	1	2	4
harbor seal		2		2
harbor porpoise	2	4		6
<b>Bird Total</b>	<b>27</b>	<b>15</b>	<b>34</b>	<b>76</b>
<b>Birds/km<sup>2</sup></b>	<b>4.7</b>	<b>1.8</b>	<b>21.3</b>	<b>9.2</b>

On October 16<sup>th</sup>, conditions were rated as “Fair” due to a heavy downpour that began on the first transect but ended at the start of the north quadrat and therefore conditions returned gradually to “Maximum.” Seas were at most a half foot (0.15m) but decreased to a ripple by the end. Winds were from the SSW at only three knots. The VoltturnUS turbine was not spinning at the time of the survey. Map 15 shows the general survey tracklines with the location and number of animals recorded. Of the seven total bird species identified on this date, 45% were found in the BR but included only four species, followed by 36% found in the north quadrat, and 20% in the south quadrat. The top three species on this day were the HERG (53%), followed by BLGU at 26%, and 6.6% were common loons (*Gavia immer*; COLO) (Table 23). Two harbor porpoise were observed in the north quadrat but four were observed in the south quadrat along with two harbor seals.

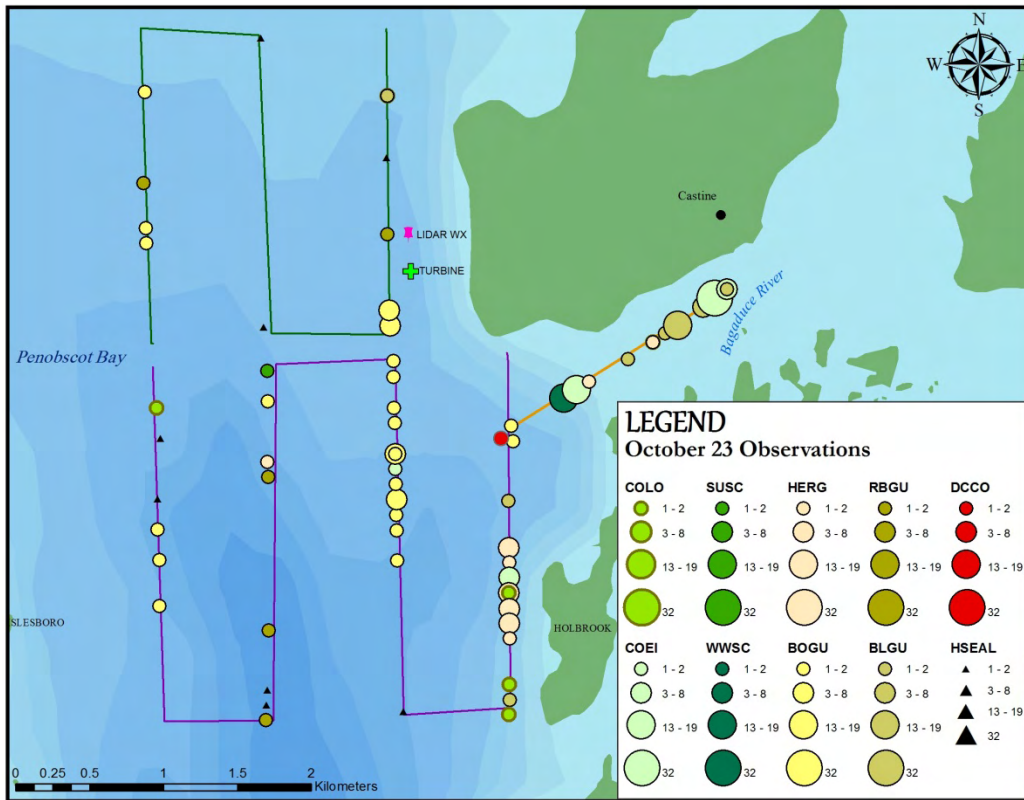
Table 24 shows all behaviors by all bird species observed. Seventy percent of all birds were observed sitting in the water, followed by 18% flying direct. Of all birds, 3.9% demonstrated a foraging behavior (n=3), with two of the birds milling in the north quadrat, and one milling in the BR. Of the flying birds, 50% flew at a height of one meter, and 27% flew at five meters.

Table 24. Bird species, behavior code, and flight height on October 16.

BEHAVIOR	1	10	20				35		48		Total
HEIGHT (m)	0	0	1	5	10	20	1	5	2	5	
COLO	5										5
COEI			1	1							2
UNDU			2								2
HERG	29	1	2		1	2	1		2	2	40
BOGU								2		1	3
BLGU	17		3								20
DCCO	2		2								4
<b>Grand Total</b>	<b>53</b>	<b>1</b>	<b>10</b>	<b>1</b>	<b>1</b>	<b>2</b>	<b>1</b>	<b>2</b>	<b>2</b>	<b>3</b>	<b>76</b>



Map 15. Observations of wildlife during October 16 survey.



Map 16. Observations of wildlife during October 23 survey.

Table 25. Numbers of species observed during the morning survey of October 23.

SPECIES	N	S	BR	Total
common loon	1	4	2	7
common eider		5	48	53
surf scoter		1		1
white-winged scoter			19	19
herring gull		24	3	27
Bonaparte's gull	9	26		35
ring-billed gull	2	3		5
black guillemot	1	2	23	26
double-crested cormorant		1		1
harbor seal	4	6		10
<b>Bird Total</b>	<b>13</b>	<b>66</b>	<b>95</b>	<b>174</b>
<b>Birds/km<sup>2</sup></b>	<b>2.2</b>	<b>8.0</b>	<b>59.4</b>	<b>23.2</b>

On October 23<sup>rd</sup>, conditions were rated as “Maximum” with seas from flat to only a ripple (0.01m), with winds from the W at one knot and a clear sky. The VoltturnUS turbine was not spinning at the time of the survey. Map 16 shows the general survey tracklines with the location and number of animals recorded. Of the nine total bird species observed on this date, 55% were found in the BR and included eight species, followed by 38% found in the south quadrat, and 7.5% in the north quadrat. The top three species on this day were common eider (*Somateria mollissima*; COEI) with 30%, followed by BOGU at 20%, and HERG with 16% (Table 25). Only four harbor seals were observed in the north quadrat, and six were observed in the south.

Table 26 shows all behaviors by all bird species observed. Fifty-six percent of all birds were observed sitting in the water, followed by 33% of birds flying direct. Of all birds, 9.2% demonstrated a foraging behavior; 94% of the foraging occurred in the south quadrat, with only one bird pattering in the north. Of the flying birds, 54% were flying at a height of one meter, and 25% were at five meters.

Table 26. Bird species, behavior code, and flight height on October 23.

BEHAVIOR	1					20		35		48		61		Total
	0	1	5	10	15	2	5	10	3	5				
COLO	6	1											7	
COEI	35	18											53	
SUSC		1											1	
WWSC		19											19	
HERG	23			4									27	
BOGU	9		8			1	7	2	4	4			35	
RBGU				3	1			1					5	
BLGU	25	1											26	
DCCO		1											1	
<b>Grand Total</b>	<b>98</b>	<b>41</b>	<b>8</b>	<b>7</b>	<b>1</b>	<b>1</b>	<b>7</b>	<b>3</b>	<b>4</b>	<b>4</b>			<b>174</b>	



Table 27. Numbers of species observed during the afternoon survey of October 30.

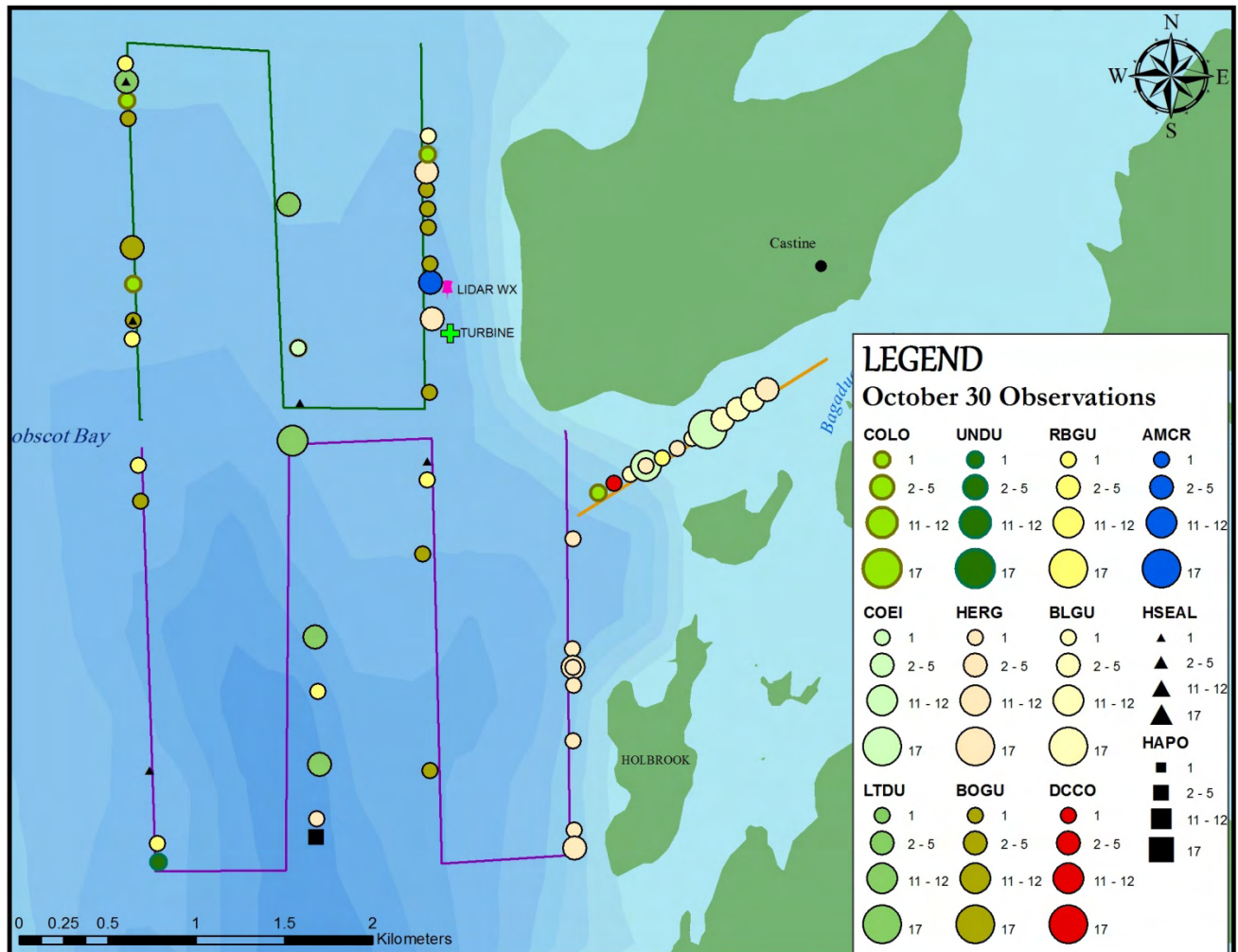
SPECIES	N	S	BR	Total
common loon	4		2	6
common eider	1		28	29
long-tailed duck	6	16		22
unidentified duck		1		1
herring gull	7	13	6	26
Bonaparte's gull	9	3		12
ring-billed gull	2	4	1	7
black guillemot	1		12	13
American crow	2			2
double-crested cormorant			1	1
harbor seal	4	4		8
harbor porpoise		5		5
<b>Bird Total</b>	<b>32</b>	<b>37</b>	<b>50</b>	<b>119</b>
<b>Birds/km<sup>2</sup></b>	<b>5.5</b>	<b>4.5</b>	<b>31.3</b>	<b>13.8</b>

On October 30<sup>th</sup>, conditions were rated as “Fair” due to a heavy downpour that began on the first transect but ended at the start of the north quadrat and therefore conditions returned gradually to “Maximum.” Seas were at most a half foot (0.15m) but decreased to a ripple by the end. Winds were practically negligible and the VoltturnUS turbine was not spinning at the time of the survey. Map 17 shows the general survey tracklines with the location and number of animals recorded. Of the 10 total bird species identified on this date, 42% were found in the BR but included only six species, followed by 31% found in the south quadrat, and 27% in the north quadrat. The top three species on this day were the COEI (29%), followed by HERG at 22%, and 18% were long-tailed ducks (*Clangula hyemalis*; LTDU) (Table 27). Four harbor seals were observed in the north quadrat and four more were observed in the south quadrat along with five harbor seals.

Table 28 shows all behaviors by all bird species observed. Seventy-two percent of all birds were observed sitting in the water, followed by 18% flying direct. Of all birds, 5.9% demonstrated a foraging behavior (n=7), with four of the birds milling in the north quadrat, and three birds demonstrating foraging activities in the south quadrat. Of the flying birds, 31% were flying at a height of five meters, and 21% flew at varying heights at or below five meters, and 21% flew at one meter.

Table 28. Bird species, behavior code, and flight height on October 16.

BEHAVIOR	1	10	20				32	35	48		65	Total		
HEIGHT (m)	0	0	1	5	10	15	<5	5	5	10	2	5	0	
COLO	3		3											6
COEI	28		1											29
LTDU	22													22
UNDU							1							1
HERG	16	1		2		3			1		1		2	26
BOGU	4			3	1	1			2	1				12
RBGU	2			1		1		1		1		1		7
BLGU	11		2											13
AMCR							2							2
DCCO		1												1
<b>Grand Total</b>	<b>86</b>	<b>2</b>	<b>6</b>	<b>4</b>	<b>3</b>	<b>2</b>	<b>6</b>	<b>1</b>	<b>3</b>	<b>2</b>	<b>1</b>	<b>1</b>	<b>2</b>	<b>119</b>



Map 17. Observations of wildlife during October 30 survey.

# NOVEMBER 4, 2013

# MORNING SURVEY (8:56am)

Table 29. Numbers of species observed during the morning survey of November 4.

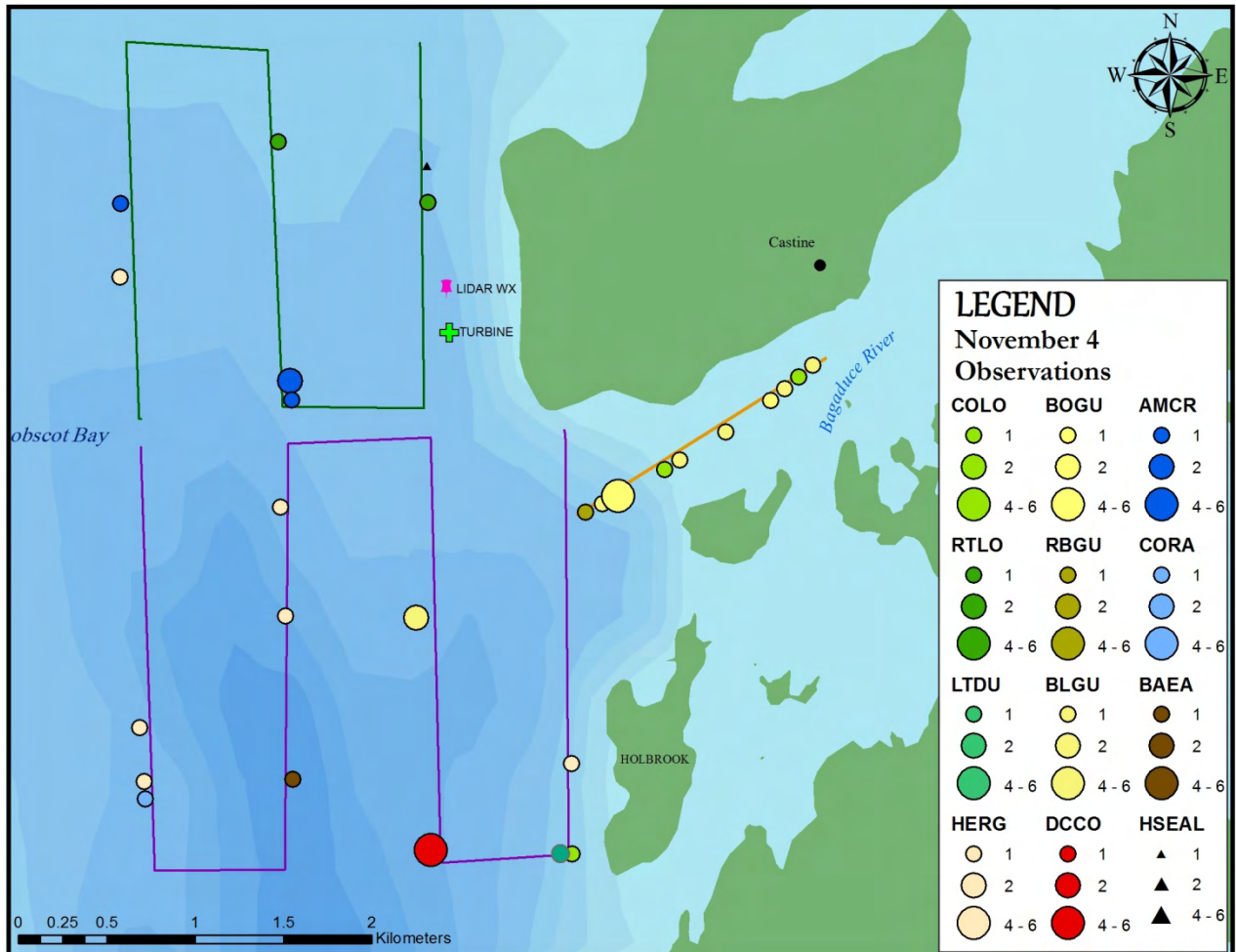
SPECIES	N	S	BR	Total
common loon		1	2	3
red-throated loon	2			2
long-tailed duck		1		1
herring gull	1	5		6
Bonaparte's gull			5	5
ring-billed gull			1	1
black guillemot		2	5	7
American crow	8			8
common raven		1		1
double-crested cormorant		6		6
bald eagle		1		1
harbor seal	1			1
<b>Bird Total</b>	<b>11</b>	<b>17</b>	<b>13</b>	<b>41</b>
<b>Birds/km<sup>2</sup></b>	<b>1.9</b>	<b>2.1</b>	<b>8.1</b>	<b>4.0</b>

On November 4<sup>th</sup>, conditions were rated as “Average” due to a high glare and seas with a two-foot chop (0.6m), and winds from the north at 10 knots and clear sky. The VoltturnUS turbine was spinning at the time of the survey. Map 18 shows the general survey tracklines with the location and number of animals recorded. Of the 11 total bird species observed on this date, 41% were found in the south quadrat and included seven species, followed by 32% found in the BR, and 27% in the north quadrat. The top four species on this day were the American crows (*Corvus brachyrhynchos*; AMCR) with 30%, followed by BLGU at 17%, and equal numbers of HERG and DCCO with 15% (Table 29). Only one harbor seal was observed in the north quadrat.

Table 30 shows all behaviors by all bird species observed. Fifty-nine percent of all birds were observed flying direct, followed by 22% of birds sitting. Of all birds, 12% demonstrated a foraging behavior (n=5); 80% of the foraging occurred in the south quadrat, with only one bird milling in the BR. Of the flying birds, 22% flew at a height of 45m, and 16% flew at 10m.

Table 30. Bird species, behavior code, and flight height on November 4.

BEHAVIOR	1				20				35				48		Total	
	0	1	2	<5	5	10	20	25	45	5	15	35	45	1		30
COLO	2				1											3
RTLO	1				1											2
LTDU	1															1
HERG						2				2	1				1	6
BOGU			1	4												5
RBGU												1				1
BLGU	5	2														7
AMCR			1			3	2	1						1		8
CORA															1	1
DCCO									6							6
BAEA													1			1
<b>Grand Total</b>	<b>9</b>	<b>2</b>	<b>2</b>	<b>4</b>	<b>2</b>	<b>5</b>	<b>2</b>	<b>1</b>	<b>6</b>	<b>2</b>	<b>1</b>	<b>1</b>	<b>1</b>	<b>1</b>	<b>2</b>	<b>41</b>



Map 18. Observations of wildlife during November 4 survey.

# NOVEMBER 13, 2013

# AFTERNOON SURVEY (14:18pm)

Table 31. Numbers of species observed during the afternoon survey of November 13.

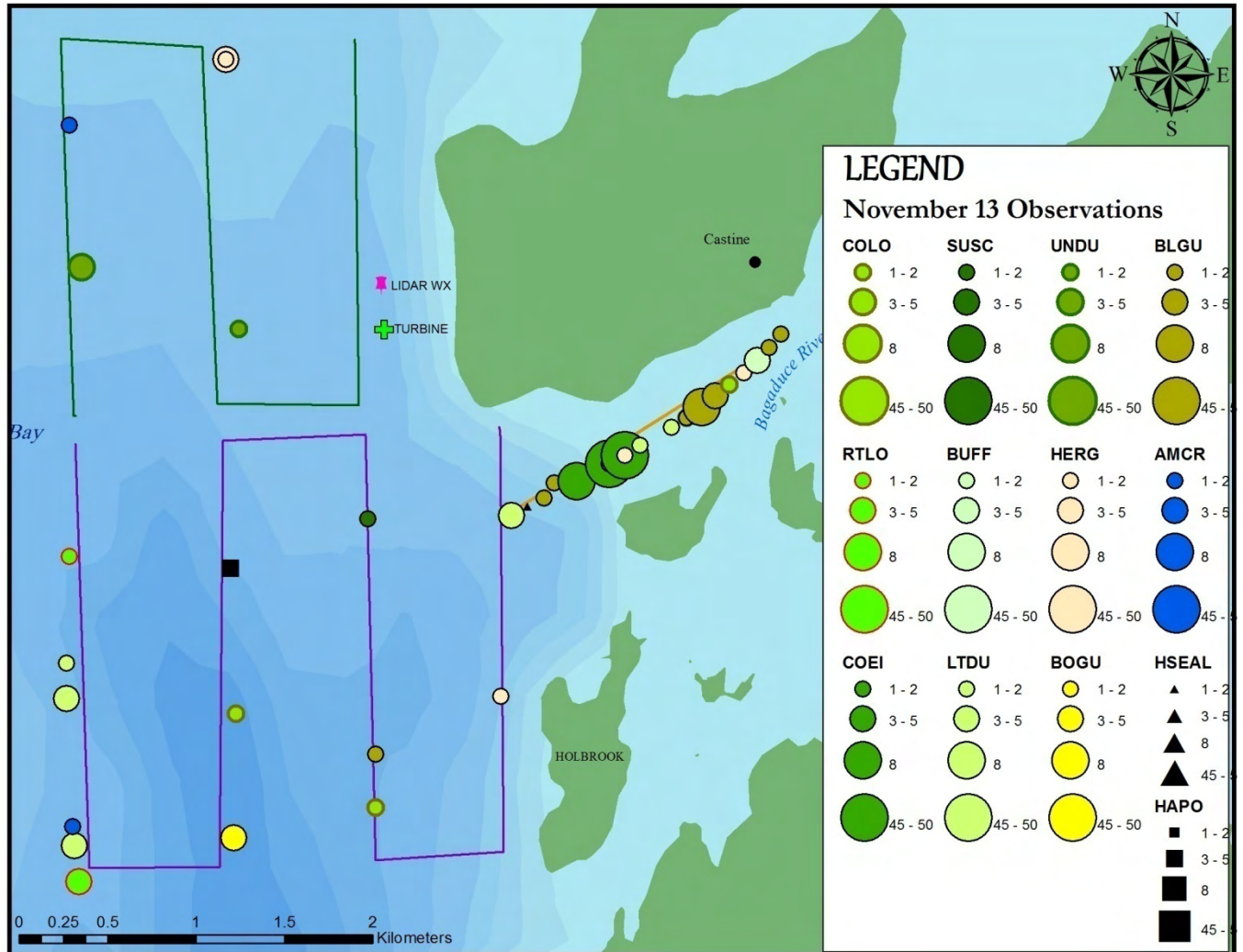
SPECIES	N	S	BR	Total
common loon		2	2	4
red-throated loon		4		4
common eider			103	103
surf scoter		1		1
bufflehead			4	4
long-tailed duck		11	7	18
unidentified duck	4			4
herring gull	5	1	3	9
Bonaparte's gull		3		3
black guillemot		2	20	22
American crow	1	1		2
harbor seal			1	1
harbor porpoise		4		4
<b>Bird Total</b>	<b>10</b>	<b>25</b>	<b>139</b>	<b>174</b>
<b>Birds/km<sup>2</sup></b>	<b>1.7</b>	<b>3.0</b>	<b>86.9</b>	<b>30.5</b>

On November 13<sup>th</sup>, conditions were rated as “Good” due to seas that were two to three feet (0.6-0.9m) and winds at 10-15 knots. Depending on direction traveled of the transect, the clear skies produced a high glare for visibility at times. The VoltturnUS turbine was spinning at the time of the survey. Map 19 shows the general survey tracklines with the location and number of animals recorded. Of the 11 total bird species identified on this date, 80% were found in the BR but included only six species, followed by 14% found in the south quadrat, and 5.7% in the north quadrat. The top three species on this day were the COEI (29%), followed by BLGU at 13%, and 10% were LTDU (Table 31). Four harbor porpoise were observed in the south quadrat and only one harbor seal was observed in the BR.

Table 32 shows all behaviors by all bird species observed. Fifty-nine percent of all birds were observed flying direct, followed by 40% sitting in the water. Of all birds, 0.5% demonstrated a foraging behavior (n=1), which involved a single HERG milling in the south quadrat at 25m. Of the flying birds, 79% flew at a height of one meter, and 13% flew at five meters.

Table 32. Bird species, behavior code, and flight height on November 13.

BEHAVIOR	1	20						35	48	
HEIGHT (m)	0	1	<5	5	20	25	30	25	2	Total
COLO	1	2			1					4
RTLO			1	3						4
COEI	53	50								103
SUSC	1									1
BUFF	4									4
LTDU		13		5						18
UNDU		3		1						4
HERG	1	1				1	4	1	1	9
BOGU				3						3
BLGU	10	12								22
AMCR		1		1						2
<b>Grand Total</b>	<b>70</b>	<b>82</b>	<b>1</b>	<b>13</b>	<b>1</b>	<b>1</b>	<b>4</b>	<b>1</b>	<b>1</b>	<b>174</b>



## DECEMBER 3, 2013

## AFTERNOON SURVEY (14:10pm)

Table 33. Numbers of species observed during the afternoon survey of December 3.

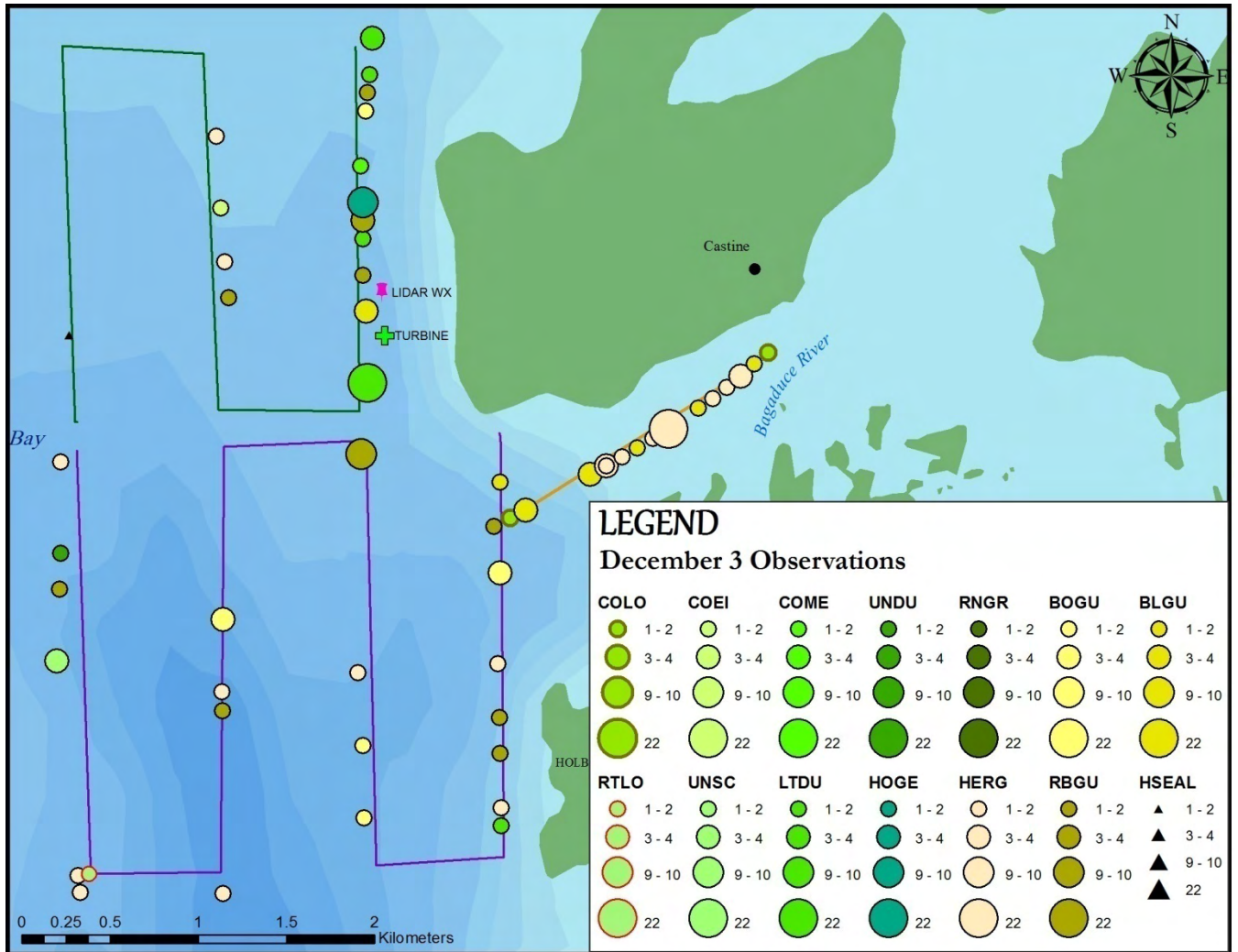
SPECIES	N	S	BR	Total
common loon			2	2
red-throated loon		1		1
common eider	1			1
unidentified scoter		3		3
horned grebe	10			10
red-necked grebe	1			1
long-tailed duck	29	2	1	32
common merganser	1			1
unidentified duck		1	1	2
herring gull	2	11	37	50
Bonaparte's gull	1	9		10
ring-billed gull	7	13	1	21
black guillemot	4	1	12	17
harbor seal	1			1
<b>Bird Total</b>	<b>56</b>	<b>41</b>	<b>54</b>	<b>151</b>
<b>Birds/km<sup>2</sup></b>	<b>9.7</b>	<b>5.0</b>	<b>33.8</b>	<b>16.1</b>

On December 3<sup>rd</sup>, conditions were rated as “Maximum” with seas averaging two feet (0.6m), with winds from the north at 10 knots and overcast skies. [Map 20](#) shows the general survey tracklines with the location and number of animals recorded. Of the 13 total bird species identified on this date, 37% were found in the north quadrat and included nine species, followed by 36% found in the BR, and 27% in the south quadrat. The VoltturnUS turbine was spinning at the time of the survey. The top three species on this day were the HERG (33%), followed by LTDU at 21%, and 14% were RBGU ([Table 33](#)). Only one harbor seal was observed in the north quadrat.

[Table 34](#) shows all behaviors by all bird species observed. Forty percent of all birds were observed flying direct, followed by 25% sitting in the water, and 18% milling. Of all birds, 25% demonstrated a foraging behavior, with 68% occurring in the BR, and 32% in the south quadrat. Of the flying birds, 38% flew at a height of one meter, and 23% flew at 20m.

Table 34. Bird species, behavior code, and flight height on December 3.

BEHAVIOR	1	20								32		35					48					61	65	
HEIGHT (m)	0	1	3	<5	5	10	15	20	25	2	10	3	5	10	20	2	<5	5	10	15	25	5	5	Total
COLO	2																							2
RTLO						1																		1
COEI		1																						1
UNSC		3																						3
HOGR	10																							10
RNGR	1																							1
LTDU	6	26																						32
COME						1																		1
UNDU		2																						2
HERG	3	1			1	2	1	2	1	1	1	1	1	3	22	1		2	2		5			50
BOGU	1		2	3	3											1								10
RBGU	4				1	3											1	1		1		1	9	21
BLGU	11	6																						17
<b>Grand Total</b>	<b>38</b>	<b>39</b>	<b>2</b>	<b>3</b>	<b>5</b>	<b>7</b>	<b>1</b>	<b>2</b>	<b>1</b>	<b>1</b>	<b>1</b>	<b>1</b>	<b>1</b>	<b>3</b>	<b>22</b>	<b>2</b>	<b>1</b>	<b>3</b>	<b>2</b>	<b>1</b>	<b>5</b>	<b>1</b>	<b>9</b>	<b>151</b>



Map 20. Observations of wildlife during December 3 survey.



Table 35. Numbers of species observed during the morning survey of December 9.

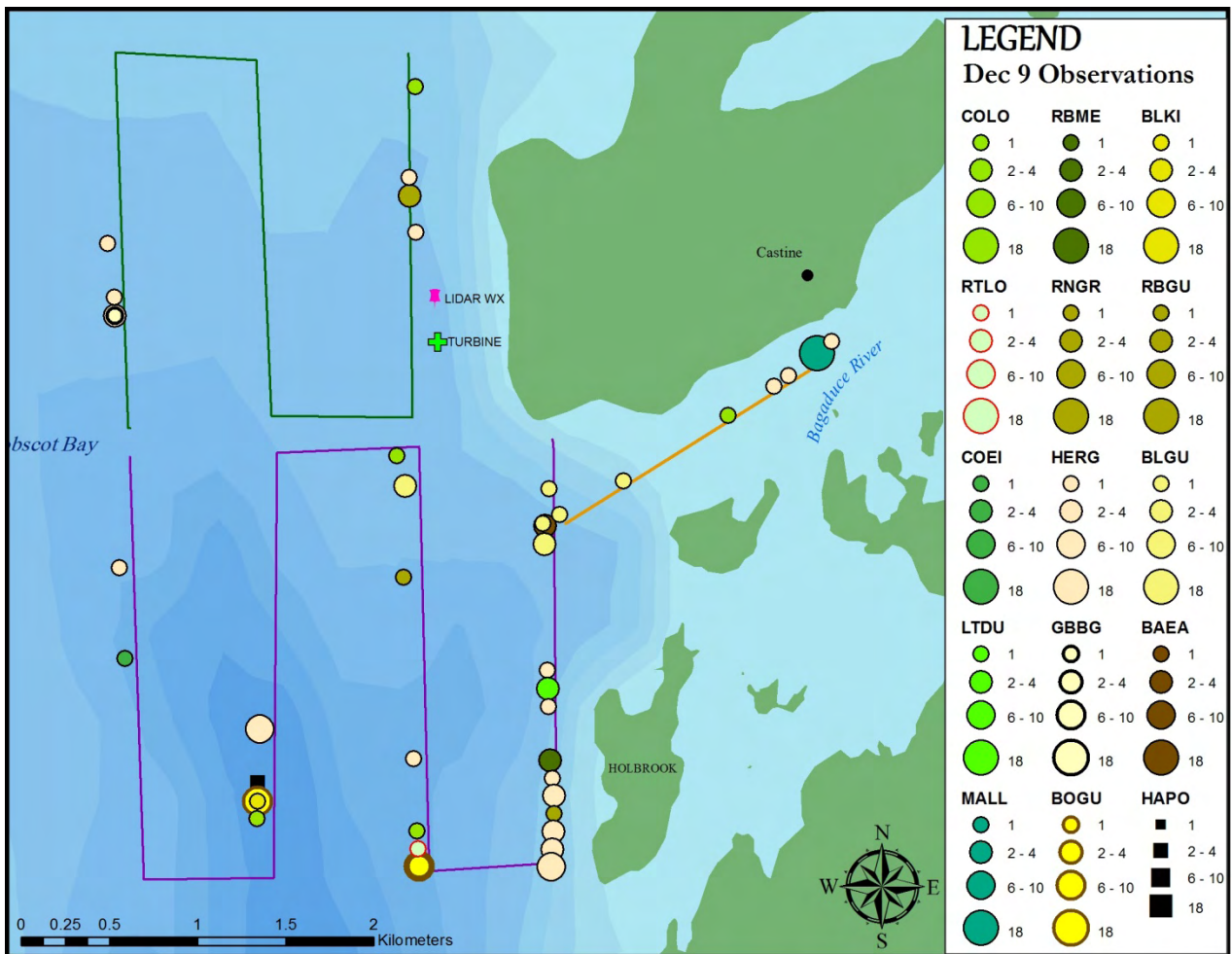
SPECIES	N	S	BR	Total
common loon	1	4	1	6
red-throated loon		1		1
common eider		1		1
red-necked grebe	3			3
long-tailed duck		2		2
mallard			18	18
red-breasted merganser		3		3
great black-backed gull	1			1
herring gull	8	31	3	42
black-legged kittiwake		1		1
Bonaparte's gull		18		18
ring-billed gull		2		2
black guillemot		6	3	9
bald eagle		2		2
harbor porpoise		3		3
<b>Bird Total</b>	<b>13</b>	<b>71</b>	<b>25</b>	<b>109</b>
<b>Birds/km<sup>2</sup></b>	<b>2.2</b>	<b>8.7</b>	<b>15.6</b>	<b>8.8</b>

On December 9<sup>th</sup>, conditions began as “Maximum” but by the middle of the south quadrat, the conditions worsened to “Average” due to increasing snow that continued to the end of the survey. Seas were at one foot (0.3m) and winds were from the east at eight knots. The VoltturnUS turbine was spinning at the time of the survey. Map 21 shows the general survey tracklines with the location and number of animals recorded. Of the 14 total bird species observed on this date, 65% were found in the south quadrat and included 11 species, followed by 23% found in the BR, and 12% in the north quadrat. The top four species on this day were HERG with 39%, followed by equal numbers of BOGU and mallards (*Anas platyrhynchos*; MALL) with 17% (Table 35). Only three harbor porpoise were observed in the south quadrat.

Table 36 shows all behaviors by all bird species observed. Fifty-seven percent of all birds were observed sitting in the water, followed by 16% of birds pattering. Of all birds, 28% demonstrated a foraging behavior; 97% of the foraging occurred in the south quadrat, with only one bird scavenging in the north quadrat. Of the flying birds, 42% flew at a height of two meters, and 16% flew at one meter.

Table 36. Bird species, behavior code, and flight height on December 9.

BEHAVIOR	1	20					32	35				48			61	65	Total
HEIGHT (m)	0	1	2	5	15	20	5	1	<5	20	25	3	5	10	2	0	
COLO	3	1		1	1												6
RTLO		1															1
COEI	1																1
RNGR	3																3
LTDU	2																2
MALL	18																18
RBME	3																3
GBBG																1	1
HERG	23	2				1	1	2		1		2	1	2	6	1	42
BLKI															1		1
BOGU	2								6						10		18
RBGU	1			1													2
BLGU	6	1	2														9
BAEA											2						2
<b>Grand Total</b>	<b>62</b>	<b>5</b>	<b>2</b>	<b>2</b>	<b>1</b>	<b>1</b>	<b>1</b>	<b>2</b>	<b>6</b>	<b>1</b>	<b>2</b>	<b>2</b>	<b>1</b>	<b>2</b>	<b>17</b>	<b>2</b>	<b>109</b>



Map 21. Observations of wildlife during December 9 survey.

Table 37. Numbers of species observed during the morning survey of December 20.

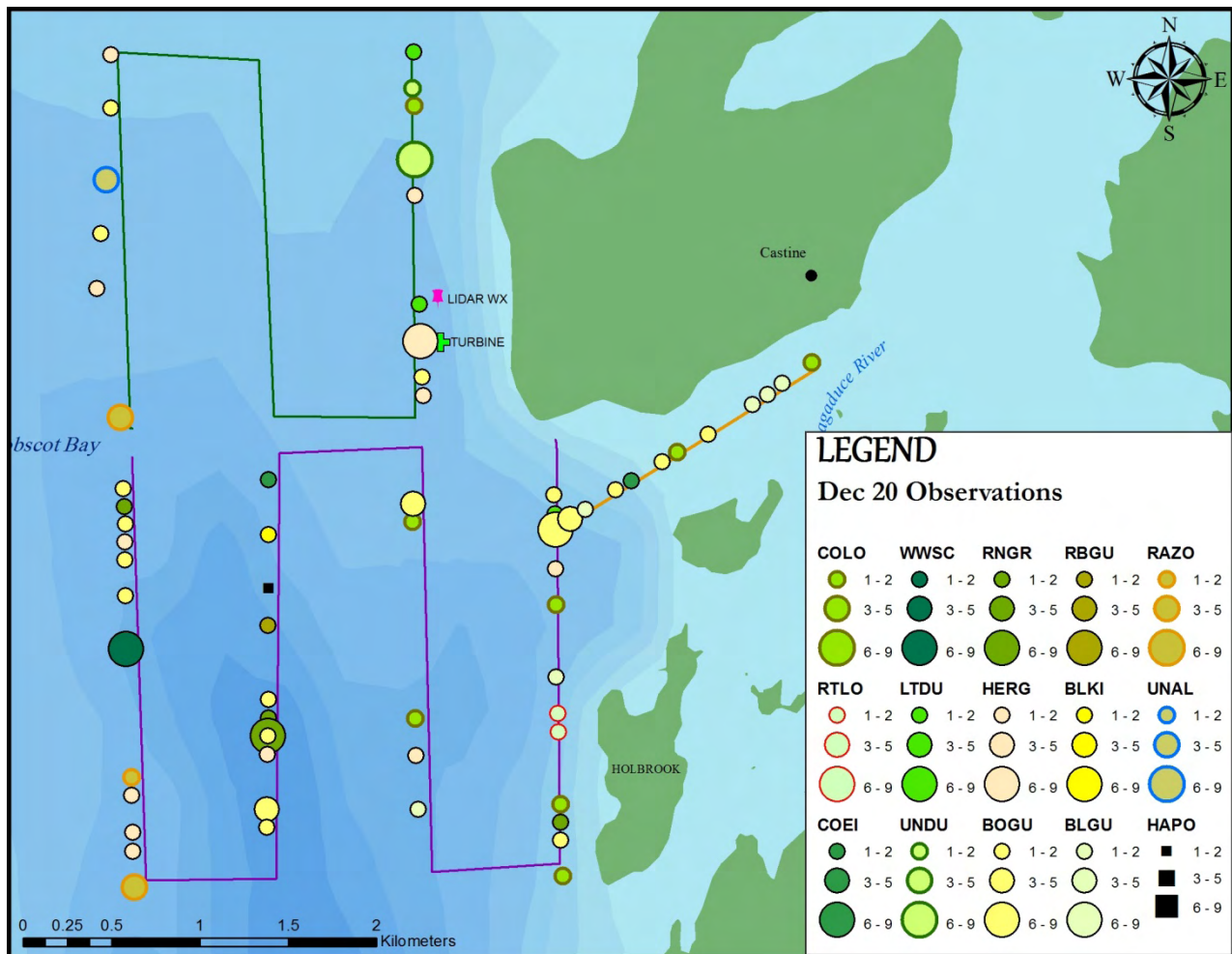
Row Labels	N	S	BR	Total
common loon	1	6	2	9
red-throated loon		2		2
common eider		1	2	3
white-winged scoter		8		8
red-necked grebe		13		13
long-tailed duck	3	2		5
unidentified duck	7			7
herring gull	12	7		19
black-legged kittiwake		1		1
Bonaparte's gull	3	20	16	39
ring-billed gull		1		1
black guillemot		2	5	7
razorbill		7		7
unidentified alcid	5			5
harbor porpoise		2		2
<b>Bird Total</b>	<b>31</b>	<b>70</b>	<b>25</b>	<b>126</b>
<b>Birds/km<sup>2</sup></b>	<b>7.4</b>	<b>8.5</b>	<b>15.6</b>	<b>10.5</b>

On December 20<sup>th</sup>, conditions began as “Maximum” with seas from a ripple to one-half foot (0.01-0.15m) and winds were from the east at four knots with an overcast sky. The VolturnUS turbine was not spinning at the time of the survey. Due to a minor equipment malfunction, the second strip of the north quadrat was unable to record data; therefore total survey area on the north quadrat equaled 4.2km<sup>2</sup>, and the day’s total survey area equaled 14km<sup>2</sup>. Map 22 shows the general survey tracklines with the location and number of animals recorded. Of the 13 total bird species identified on this date, 56% were found in the south quadrat and included 12 species, followed by 25% found in the north quadrat, and 20% in the BR. The top three species on this day were BOGU with 31%, followed by BOGU at 15%, and red-necked grebe (*Podiceps grisegena*; RNGR) with 10% (Table 37). Only two harbor porpoise were observed in the south quadrat.

Table 38 shows all behaviors by all bird species observed. Forty-four percent of all birds were observed flying direct, followed by 25% of birds sitting in the water. Of all birds, 22% demonstrated a foraging behavior; 57% of the foraging occurred in the BR, with 25% in the south quadrat, and 18% in the north. Of the flying birds, 31% flew at a height of one meter, and 24% flew at three meters.

Table 38. Bird species, behavior code, and flight height on December 20.

BEHAVIOR	20									32			35				48				61		70	Total	
	0	1	2	3	5	10	25	40	45	5	10	15	1	2	3	10	1	3	5	15	2	3	0		
COLO	7	1		1																					9
RTLO	1																	1							2
COEI		3																							3
WWSC		8																							8
RNGR	3	9				1																			13
LTDU	4	1																							5
UNDU	7																								7
HERG						1	9	2	1	1	1	2								1					19
BLKI														1											1
BOGU			7	7	1								1	4	4					2	1		5	7	39
RBGU					1																				1
BLGU	4	2																		1					7
RAZO	6	1																							7
UNAL																								5	5
<b>Grand Total</b>	<b>32</b>	<b>25</b>	<b>7</b>	<b>8</b>	<b>2</b>	<b>2</b>	<b>9</b>	<b>2</b>	<b>1</b>	<b>1</b>	<b>1</b>	<b>2</b>	<b>1</b>	<b>5</b>	<b>4</b>	<b>1</b>	<b>2</b>	<b>2</b>	<b>1</b>	<b>1</b>	<b>5</b>	<b>7</b>	<b>5</b>	<b>126</b>	



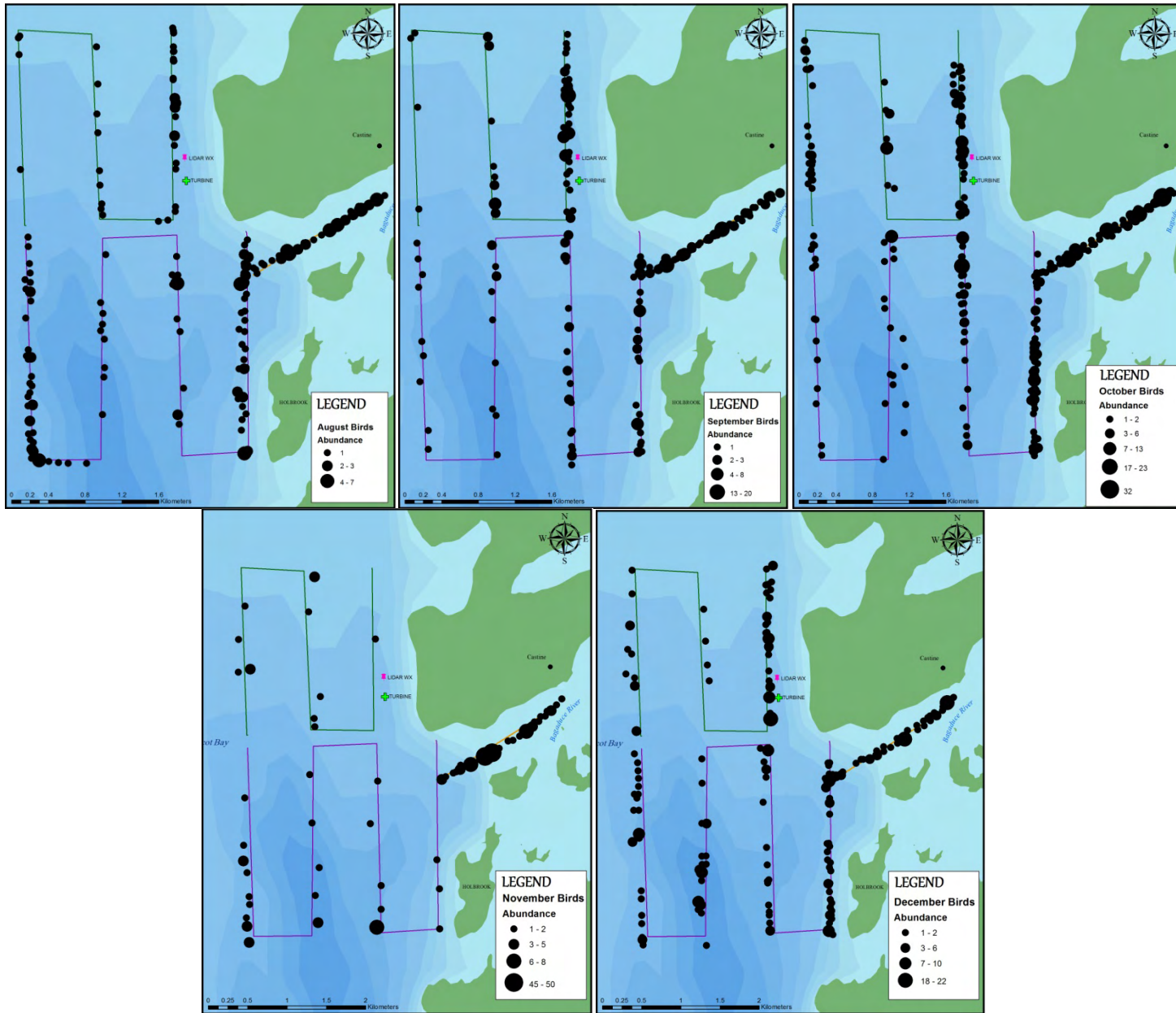
Map 22. Observations of wildlife during December 20 survey.

## B. *Bird Species Abundance and Diversity, August-December 2013*

Of the 17 days, the greatest abundance of wildlife was observed on November 13<sup>th</sup> with 30.5/km<sup>2</sup> (Map 19), and the least abundance was on August 7<sup>th</sup> with 3.6/km<sup>2</sup> (Map 7). Maps 23 a-f show overall distribution of all bird and other wildlife species throughout the 17 surveys, by month. All wildlife species observed within the Castine Test Site are presented in Tables 39 a, b, & c, in order of greatest density to least, according to quadrat. The north and south quadrats were most similar in the top species composition, with HERG, BOGU, and RBGU as the top three bird species. Black guillemot and COEI were the first and second most abundant birds overall (Table 38d), yet the greatest portion of their abundance came from the BR, with 72% and 94%, respectively. Of the separate transects, the south quadrat had the greatest diversity of species, with 28 identified species of birds and three species of marine mammal, whereas the BR had 15 species of birds and only one marine mammal species.

Tables 39a, b, c, & d: Species, numbers and wildlife from most abundant to least. (a) Species abundance and densities for the north quadrat; (b) south quadrat; (c) Bagaduce River quadrat; (d) and overall total Castine Test Site.

SPP	NORTH	N/km <sup>2</sup>	SPP	SOUTH	S/km <sup>2</sup>	SPP	BR	BR/km <sup>2</sup>	SPP	Total	Tot/km <sup>2</sup>
HERG	104	1.10	BOGU	199	1.43	COEI	181	6.65	BLGU	248	2.372
BOGU	90	0.92	HERG	154	1.10	BLGU	179	6.58	COEI	193	2.250
RBGU	60	0.61	RBGU	109	0.78	BOGU	105	3.86	BOGU	394	2.071
LTDU	38	0.40	BLGU	55	0.39	HERG	92	3.38	HERG	350	1.863
HSeal	18	0.18	HAPO	50	0.36	RBGU	58	2.13	RBGU	227	1.174
COLO	14	0.15	LTDU	34	0.24	COLO	23	0.85	COLO	59	0.383
BLGU	14	0.14	HSeal	24	0.17	DCCO	22	0.81	DCCO	47	0.334
UNDU	11	0.14	COLO	22	0.16	WWSC	19	0.70	LTDU	80	0.312
HAPO	13	0.13	DCCO	20	0.14	MALL	18	0.66	WWSC	37	0.276
AMCR	11	0.11	WWSC	18	0.13	LTDU	8	0.29	MALL	18	0.221
HOGGR	10	0.10	SUSC	15	0.11	AMCR	8	0.29	HSeal	47	0.180
UNAL	6	0.08	RNGR	13	0.09	UNHA	8	0.29	HAPO	63	0.164
UNSC	7	0.07	COEI	9	0.06	HSeal	5	0.18	AMCR	20	0.138
UNTE	6	0.06	UNTE	9	0.06	BUFF	4	0.15	UNHA	10	0.104
DCCO	5	0.05	RTLO	8	0.06	UNDU	2	0.07	UNDU	17	0.080
RNGR	4	0.04	RAZO	7	0.05	LAGU	1	0.04	BUFF	4	0.049
LAGU	4	0.04	LAGU	5	0.04	RTLO			RNGR	17	0.045
COEI	3	0.03	COTE	5	0.04	SUSC			UNTE	15	0.042
BLKI	3	0.03	UNSC	4	0.03	UNSC			LAGU	10	0.038
RTLO	2	0.02	UNDU	4	0.03	HOGGR			SUSC	15	0.036
SHORE	2	0.02	BLKI	4	0.03	RNGR			HOGGR	10	0.034
COME	1	0.01	SHORE	4	0.03	COME			UNSC	11	0.033
GBBG	1	0.01	RBME	3	0.02	RBME			UNAL	7	0.029
COTE	1	0.01	BAEA	3	0.02	GBHE			RTLO	10	0.026
OSPR	1	0.01	OSPR	2	0.01	GBBG			BLKI	7	0.020
UNHA	1	0.01	Gseal	2	0.01	BLKI			RAZO	7	0.017
SUSC			GBHE	1	0.01	COTE			SHORE	6	0.016
WWSC			UNAL	1	0.01	UNTE			COTE	6	0.015
BUFF			AMCR	1	0.01	RAZO			OSPR	3	0.008
MALL			CORA	1	0.01	UNAL			RBME	3	0.007
RBME			UNHA	1	0.01	SHORE			BAEA	3	0.007
GBHE			TUVU	1	0.01	CORA			Gseal	2	0.005
RAZO			HOGGR			BAEA			COME	1	0.003
CORA			BUFF			OSPR			GBBG	1	0.003
BAEA			MALL			TUVU			GBHE	1	0.002
TUVU			COME			Gseal			CORA	1	0.002
Gseal			GBBG			HAPO			TUVU	1	0.002



Maps 23a-e. Observations of bird abundance by month, from August 7 through Dec 20, 2013.

## **C. Bird Behavior Categories**

Table 40 has the total numbers of all birds recorded in each quadrat, tallied by behavior. Sitting in the water was the most common behavior type recorded during the surveys throughout the entire Castine Test. Direct flight was also unanimously the second most common activity, followed by milling as third and meandering as fourth. In all behaviors, the BR presented the highest proportion of all activities among the quadrats.

Table 40. Densities of each bird behavior type, by quadrat.

QUADRAT	BEHAVIOR TYPE										Total
	1	10	20	29	32	35	48	61	65	70	
North	2.06		1.36		0.03	0.22	0.10	0.08	0.24	0.07	4.17
South	1.95		1.76		0.05	0.47	0.22	0.22	0.43	0.01	5.11
Bagaduce R.	15.77	0.66	6.29	0.04		1.65	1.18	0.44	0.63	0.11	26.76
<b>Total (per km<sup>2</sup>)</b>	<b>19.78</b>	<b>0.66</b>	<b>9.41</b>	<b>0.04</b>	<b>0.08</b>	<b>2.34</b>	<b>1.49</b>	<b>0.74</b>	<b>1.30</b>	<b>0.19</b>	<b>36.04</b>

### **❖ 1. SITTING ON THE WATER (Code #1)**

Throughout the surveys, 49% (19.8 birds/km<sup>2</sup>) of all the recorded birds in the Castine Test Site were observed sitting on the water, which is a behavior category not meant to suggest or exclude feeding activity. This was the most common behavior observed overall, followed by direct flight (9.4 birds/km<sup>2</sup>). Behaviors described as ‘sitting’ may include sleeping, preening, or resting. In the north quadrat HERG, BOGU, and LTDU were the top three species observed sitting (greatest to lesser); BOGU, HERG, and BLGU were the top three in the south; and BLGU, COEI, and BOGU were in the BR. The largest flock of sitting birds recorded during this survey season involved a single flock of 45 COEI near the shore in the BR on November 11<sup>th</sup>. Of the five bird Order-Groupings, Group 2: Charadriiformes (2C) represented 71% of the birds sitting on the water, followed by Group 1: Anseriformes (28%) (1A).

### **Flying Behaviors**

Flight height and behavior were recorded in the three quadrats, and the following figures will show flight heights for the three most common flight behavior categories, separated into the north, south, and BR quadrats: Direct Flight, Milling, and Meandering.

### **❖ 2. DIRECT FLIGHT (Code #20 & 29)**

Direct flight is described as a bird flying consistently through the area, not actively involved in foraging or other activities. The designation of this behavior during the survey is taken at the precise moment it is noticed by the surveyor. For analysis purposes, the single case involving the category called “Variable Heights” (code 29) has been combined

with “Direct Flight” (code 20) in the following discussion because it is a form of flight that also involves a direct path; however the bird tends to vary in height within the brief moment of observation that one height cannot be claimed. Hereafter, these codes will be called “direct flight” for simplification purposes.

Of all bird behaviors, direct flight was the second most common behavior observed throughout the entire Castine Test Site (30%; 9.5 birds/km<sup>2</sup>) (Table 40). In the north quadrat, HERG, LTDU, and BOGU were the top three species (greatest to lesser) demonstrating direct flight; BOGU, HERG, and white-winged scoter (*Melanitta fusca*; WWSC) were in the south quadrat; and COEI, BLGU, and WWSC in the BR. Table 41 shows the top six species, numbers, and average flight height during this behavior type in all quadrats.

Table 41. Densities and average flight height of the top six species in direct flight.

North species	Density (/km <sup>2</sup> )	Avg. Ht (m)	South species	Density (/km <sup>2</sup> )	Avg. Ht (m)	BR Species	Density (/km <sup>2</sup> )	Avg. Ht (m)
LTDU	4.20	1	WWSC	2.20	3.2	COEI	40.63	1
UNDU	0.69	2	LTDU	1.59	2.5	WWSC	11.88	1
HERG	7.79	16	HERG	4.63	8.9	HERG	10.63	4.6
BOGU	3.06	5.2	BOGU	5.24	4	BOGU	5.63	3
RBGU	2.93	10.4	RBGU	3.17	7.4	RBGU	6.88	3
AMCR	1.72	10.4	DCCO	2.32	14.9	BLGU	16.88	1

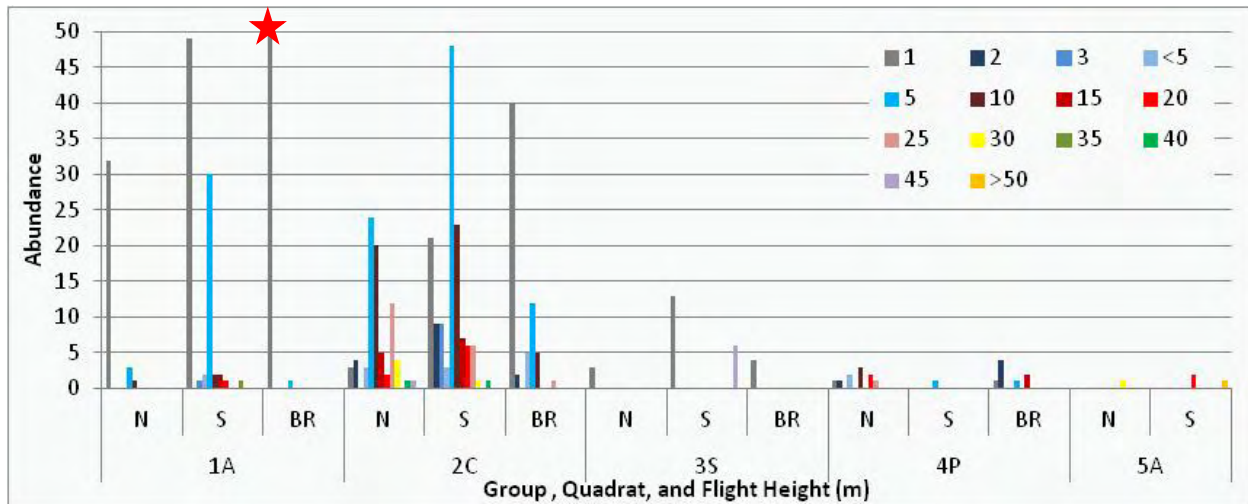


Figure 1. Direct flight by group displaying flight heights in the north, south, and BR quadrats for Group 1: Anseriformes; Group 2: Charadriiformes; Group 3: Suliformes; Group 4: Passeriformes; and Group 5: Accipiteriformes. The red star indicates 94 birds in Group 1A in the BR.



For direct flight, Group 1A had 43% in the BR quadrat and 40% in the south quadrat flying most often at one meter (80%) and at five meters (16%) (Figure 1). Of Group 2C, 48% flew in the south quadrat and 28% flew in the north, most often at five meters (30%) and one meter (23%). In Group 3S, 73% were found in the south quadrat, flying mostly at one meter (77%). Group 4P had 53% in the north quadrat and 42% in the BR, flying mostly at two meters (26%). Of only four birds in group 5A, 75% were found in the south quadrat and 50% of the flying birds were at 20m.

### Direct Flight Behavior Summary

Throughout the entire Monhegan Test Site, 49% of all birds demonstrating direct flight flew within one meter of the water’s surface, followed by 22% at five meters. Charadriiforms (2C) represented the most common species group in direct flight for the north and south quadrats, but Anseriforms (1A) were the most common in the BR.

### ❖ 3. MILLING FLIGHT (Code #35)

Milling flight is described as a bird flying in a more distinct circling or milling path that is usually associated with foraging search patterns. Similar to meandering flight, general direction of milling flight constantly changes, thus flight direction is rarely noted in the survey data for these birds.

Of all bird behaviors, milling flight was the third most common behavior observed throughout the entire Castine Test Site (7.2%; 2.3 birds/km<sup>2</sup>), as seen in Table 40. In the north quadrat, BOGU, black-legged kittiwake (*Rissa tridactyla*; BLKI), and RBGU were the top three species (greatest to lesser) demonstrating milling flight; BOGU, HERG, and RBGU were in the south quadrat; and HERG, BOGU, and RBGU in the BR. Table 42 shows the top four species, numbers, and average flight height during this behavior type in all quadrats, except in the BR where only three species were observed milling.

Table 42. Densities and average flight height of the top four species in milling flight.

North species	Density (/km <sup>2</sup> )	Avg. Ht (m)	South species	Density (/km <sup>2</sup> )	Avg. Ht (m)	BR Species	Density (/km <sup>2</sup> )	Avg. Ht (m)
LAGU	0.34	2	HERG	1.83	6.9	HERG	18.13	16.9
BLKI	0.52	3	BOGU	4.02	3.4	BOGU	6.88	4.6
BOGU	1.72	5.2	RBGU	0.73	5.8	RBGU	3.13	10.2
RBGU	0.52	5.3	BAEA	0.37	31.7			

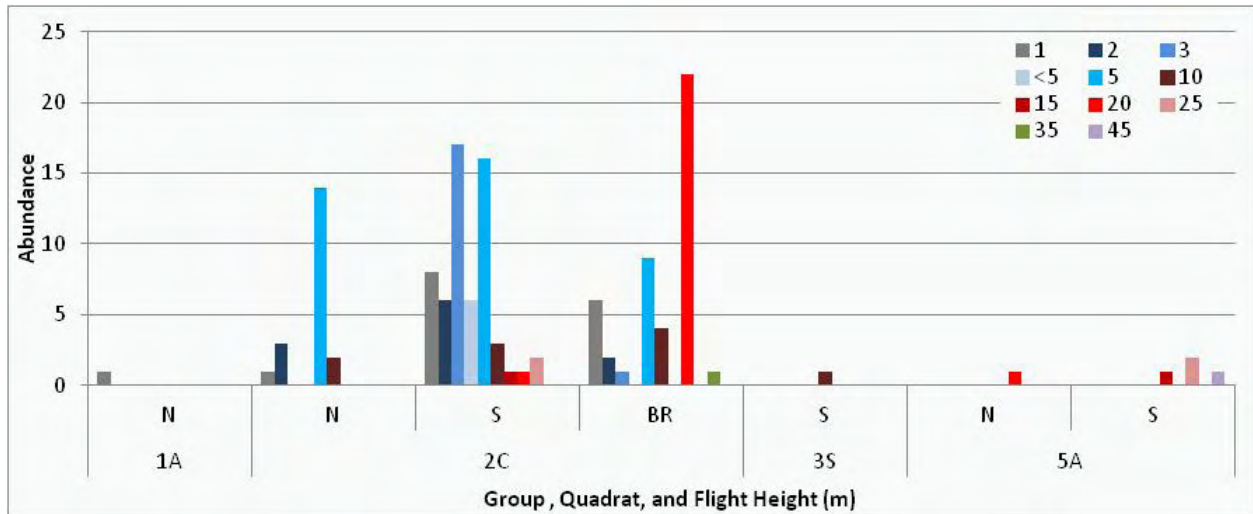


Figure 2. Milling flight by group displaying flight heights in the north, south, and BR quadrats for Group 1: Anseriformes/Gaviiformes; Group 2: Charadriiformes; Group 3: Suliformes; and Group 5: Accipiteriformes.

In the Castine Test Site, only Group 4P did not display milling behavior but only one COLO in Group 1A milled at one meter in the north quadrat, and only one DCCO in Group 3S flew at 10m in the south quadrat. (Figure 2). For milling flight, 95% of the birds consisted of Group 2C. Among them, 70% milled at five meters in the north quadrat, 60% milled between three and five meters in the south quadrat, and 49% milled at 20m in the BR. In Group 5A, only one osprey (*Pandion haliaetus*; OSPR) milled at 20m in the north, and 40% (two BAEA) milled at 25m in the south.

### Milling Flight Behavior Summary

Throughout the entire Castine Test Site, 30% of all birds demonstrating milling flight flew at five meters above the water's surface, followed by 18% flying at 20m. Group 2: Charadriiformes represented the vast majority of the species in milling flight for all Quadrats.

### ❖ 4. MEANDERING FLIGHT (Code #48)

Meandering flight is defined as a bird flying in a 'wandering' manner, not directly feeding or moving in any particular direction or with any obvious purpose. Flight direction constantly changes, thus flight direction is rarely noted in the survey data for these birds. The designation of this behavior during the survey is taken at the precise moment it is noticed by the surveyor.

In sheer numbers, the third most common bird behavior is "Scavenging" (Code #65) with 5.5%, whereas meandering flight is the fourth most common behavior with 3.9%.

However in density, meandering is the third most common behavior with 1.5 birds/km<sup>2</sup> and scavenging was observed with 1.3 birds/km<sup>2</sup> (Table 40). Scavenging will be discussed in the following section titled “Foraging and All Other Behaviors.” In the north quadrat, RBGU, BOGU, and HERG were the top three species displaying meandering behavior; HERG, RBGU, and BOGU were for the south, and HERG, unidentified hawks (UNHA), and BOGU were for the BR, as seen in Table 43.

Table 43. Densities and average flight height of the top three species in meandering flight.

North species	Density (/km <sup>2</sup> )	Avg. Ht (m)	South species	Density (/km <sup>2</sup> )	Avg. Ht (m)	BR Species	Density (/km <sup>2</sup> )	Avg. Ht (m)
RBGU	0.52	6.7	HERG	1.71	8.9	HERG	11.25	10.6
BOGU	0.41	7.5	RBGU	0.85	5.2	UNHA	5	4.3
HERG	0.34	7.5	BOGU	0.73	4.2	BOGU	2.5	50

In the Castine Test Site, only Group 3S did not display meandering behavior. Only one red-throated loon (*G. stellata*; RTLO) in Group 1A meandered at one meter in the south quadrat (Figure 6). In Group 5A only one AMCR meandered at one meter in the north quadrat and one common raven (*Corvus corax*; CORA) meandered at 30m in the south. Eight unidentified hawks meandered at 50m in the BR on September 18, 2013, which also coincided with additional observations outside of the survey area of other migrating hawk species across the Castine peninsula area.

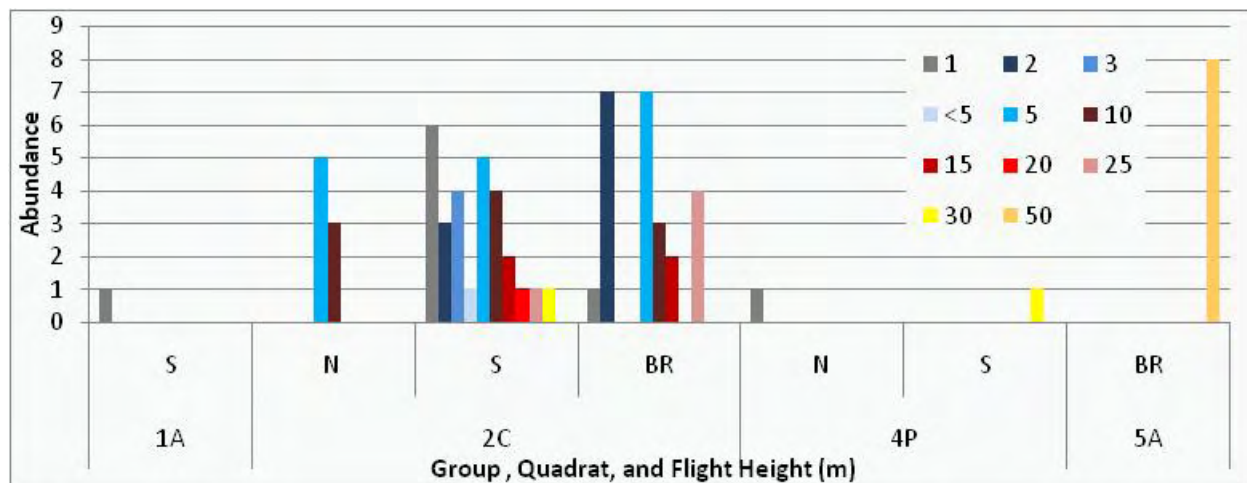


Figure 3. Meandering flight by group displaying flight heights in the north, south, and BR quadrats for Group 1: Anseriformes; Group 2: Charadriiformes; Group 4: Passeriformes; and Group 5: Accipiteriformes.

For meandering flight, 85% of the birds consisted of Group 2C. Among them, 63% meandered at five meters in the north quadrat, 21% meandered at one meter in the south quadrat, and 29% meandered at both two and five meters in the BR.

## Meandering Flight Behavior Summary

Throughout the entire Castine Test Site, 24% of all birds demonstrating meandering flight flew at five meters above the water's surface, followed by 14% flying at both two and 10m. Again, Group 2: Charadriiformes represented the vast majority of the species in meandering flight for all Quadrats.

### ❖ 5. FORAGING AND ALL OTHER BEHAVIORS

The previous discussion focused on many behaviors that most likely are not associated with, or due to the brief period of the observed moment, cannot be determined as, foraging activities. Other behaviors are, however, evident activities that involve effort to forage for food either at the surface or below the water. These include dipping or pattering (behavioral code #61), surface scavenging (#65), and pursuit diving (#70). Milling flight (#35) is also considered as a foraging behavior; it has been discussed in the previous section regarding flight behaviors but will be incorporated again in this section.

For behavioral category comparisons, we will focus on the combination of the above-mentioned four foraging behaviors in this following discussion. Table 44 shows the species abundance and locations of these foraging activities. Although the majority (54%) of all foraging birds was located in the south quadrat (1.13 birds/km<sup>2</sup>), only 26% of all foragers were in the BR, however their density was greater (2.83 birds/km<sup>2</sup>).

Table 44. Foraging type and species abundance per quadrat.

SPECIES	North Quadrat					South Quadrat					Bagaduce River				Grand Total	
	BEHAVIOR				N Total	BEHAVIOR				S Total	BEHAVIOR			BR Total		
	35	61	65	70		35	61	65	70		35	61	65			70
COLO	1				1									2	2	3
GBBG			1		1											1
HERG			5		5	15	6	5		26	29				29	60
LAGU	2				2	1	1			2						4
BLKI	3				3	2	1			3						6
BOGU	10	8	5		23	33	18	22		73	11	12	7		30	126
RBGU	3		9		12	6	4	32		42	5		9		14	68
COTE	1				1	2				2						3
UNTE	1		4		5	1	1	1		3						8
BLGU								2		2			1	1	2	4
UNAL				5	5											5
DCCO						1				1						1
BAEA						3				3						3
OSPR	1				1	1				1						2
<b>Total</b>	<b>22</b>	<b>8</b>	<b>24</b>	<b>5</b>	<b>59</b>	<b>65</b>	<b>31</b>	<b>60</b>	<b>2</b>	<b>158</b>	<b>45</b>	<b>12</b>	<b>17</b>	<b>3</b>	<b>77</b>	<b>294</b>

For all the foraging behaviors, the BR quadrat had the highest densities in each foraging behavior type as well as foraging overall (2.83 birds/km<sup>2</sup>). The south quadrat revealed the second most prevalent densities in all foraging behavior types combined (1.13/km<sup>2</sup>), except for the individual category of “underwater pursuit” (code #70) where densities were slightly higher in the north quadrat. The north quadrat's overall foraging density was only 0.6 birds/km<sup>2</sup>.

Foraging activities often coincide with the presence of humans, and are commonly associated with the lobster and fishing industry that is prevalent in the GOM. Large gulls such as HERG, GBBG, and LAGU commonly search for easy reliable foraging opportunities and therefore are attracted to vessels that commonly discard offal or bycatch (Schwemmer & Garthe 2005). Throughout the overall Castine Test Site, the majority of these foraging activities were displayed by the Charadriiformes (97%), with 89% of these Group 2C birds consisting entirely of HERG, BOGU, and RBGU. Additionally, all scavenging birds (sitting while eating food off the surface; code #65) were attributable entirely by the Order Charadriiformes. Other than five unidentified terns (UNTE) and one BLGU, these scavenging birds consisted entirely of gulls. Figure 7 below displays a selection of behaviors separated by quadrat that include boat following (#32), milling (#35), pattering (#61), scavenging (#65), and underwater pursuit (#70).

Throughout the survey season, three birds in the north quadrat and seven in the south were recorded as ‘Following a Vessel’ (code #32); of which all 10 were following *our* survey vessel and were not associated with a fishing vessel or food. Of these birds, eight were HERG, divided into two occurrences in the north and six in the south, and the remaining two were RBGU with one in the north and one in the south. Flight heights for the HERG averaged 8.1m and the RBGU averaged five meters.

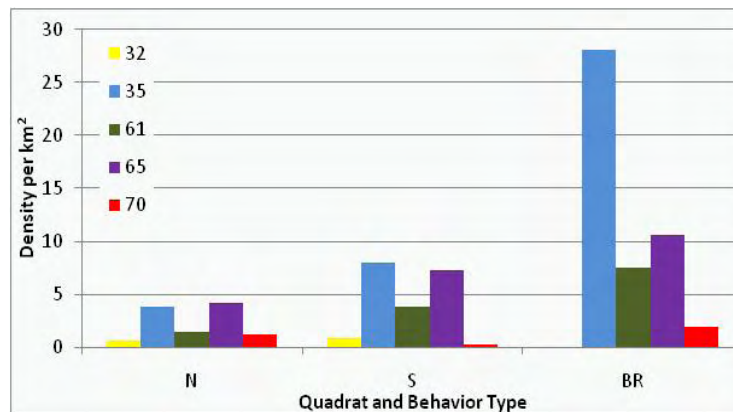


Figure 4. Selected (foraging) bird behaviors by quadrat.

Again, due to the large number of scavenging Charadriiforms (Group 2C), the greatest proportion of foraging heights were at 0-m (31%), referring to them sitting on the water (Figure 5). However, the next most common height of foraging flight activities was at five meters (23%), again consisting entirely of Group 2C. Only in the BR were a large number of foraging birds found flying within the turbine's Rotor Sweep Zone, although the majority of these sightings were further up the Bagaduce River and on the western shore of West Brooksville, rather due east of the turbine's actual location, and therefore likely not in harm's way.

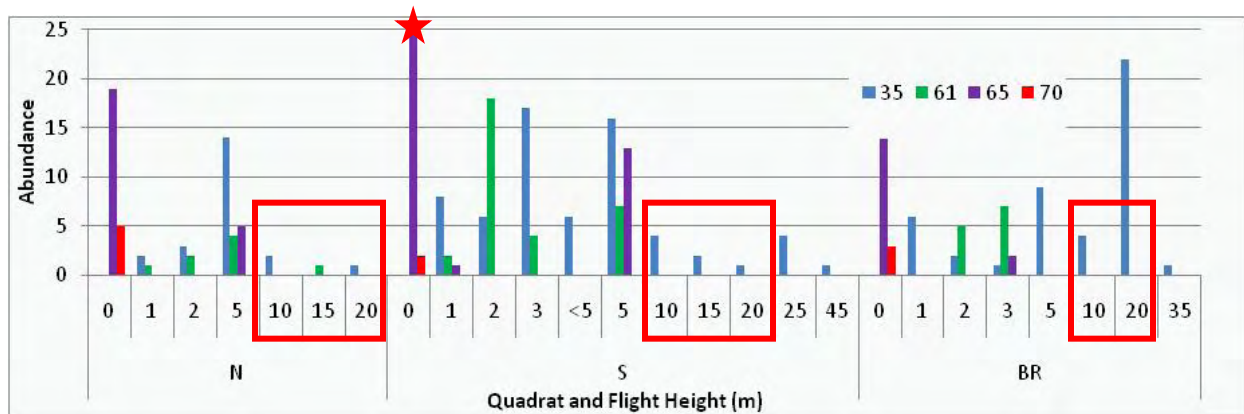


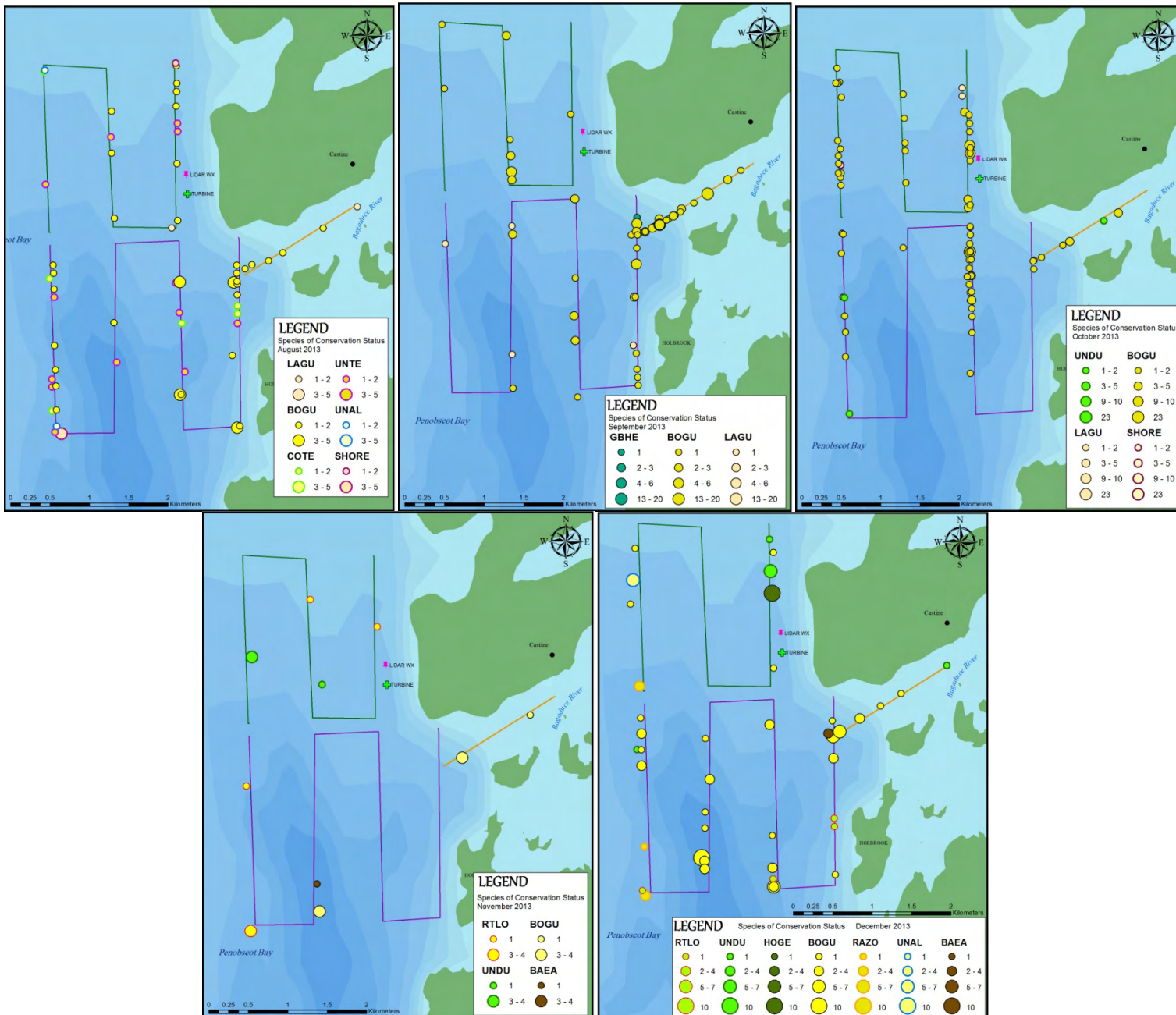
Figure 5. Flight heights of foraging behaviors per quadrat in 2013. The red star indicates 48 birds scavenging at 0-m height in the south quadrat. The red boxes indicate Rotor Sweep Zone heights.

## **D. ENDANGERED, THREATENED, AND BIRDS OF CONSERVATION CONCERN**

There are two ESA-listed birds *that have the potential to occur in the project area*, federally endangered (FE) roseate tern (*Sterna dougallii*) and federally threatened (FT) piping plover (*Charadrius melodus*). The red knot (*Calidris canutus*) is a candidate species for federal listing (F\*). A number of bird species are also listed under the Maine ESA (MDIFW). A selection of these species in this designation *that have the potential to occur within our survey area* include but are not limited to the harlequin duck (*Histrionicus histrionicus*); Arctic (*S. paradisaea*), least (*S. antillarum*), and black tern (*Chlidonias niger*); Atlantic puffin (*Fratercula arctica*); and razorbill.

In addition, the U.S. Fish & Wildlife Service (USFWS) created a list of species requiring special conservation action and awareness entitled the *Birds of Conservation Concern 2008* (BCC 2008). Of these species, birds *that may have the potential to occur in our survey area* include, but are not limited to, the red-throated loon; horned grebe (*P. auritus*; HOGGR); bald eagle (*Haliaeetus leucocephalus*; BAEA); peregrine falcon (*Falco peregrinus*); solitary (*Tryngites solitaria*), purple (*C. maritima*), semipalmated, and upland sandpipers (*Bartramia longicauda*); red knot; and least and Arctic terns. Another designation created by the MDIFW for state-specific Species of Special Concern (SSC, MDIFW 2011) also list selected birds, some of which include the Barrow's goldeneye (*Bucephala islandica*), great blue heron (*Ardea herodias*; GBHE), bald eagle, Bonaparte's (*L. philadelphia*; BOGU) and laughing gulls (*L. atricilla*; LAGU), common murre (*Uria aalge*), common tern (*S. hirundo*), red knot, and semipalmated sandpiper, *of which may be found in our survey area*. The latter of these shorebird species are likely to occur in this area, although their typical breeding range is farther south. [Table 4](#), provided earlier, identifies the species and potential species of conservation designation that were recorded during these surveys.

Bird species of these conservation designations are discussed in this following section and are shown in [Map 24](#). Observed during the Castine Test Site surveys from August 7 through December 20, 2013 were a total of 486 SCC birds. Only one definitive State Threatened species was identified: the razorbill (n=7; 0.017/km<sup>2</sup>). Three other identified species are listed as a BCC (*in Bird Conservation Regions* (BCR) #14: Atlantic Northern Forests; BCR #30: New England/Mid Atlantic Coast; and USFWS Region 5: Northeast Region) (BCC 2008), and include RTLO (n=10; 0.026/km<sup>2</sup>), HOGGR (n=10; 0.033/km<sup>2</sup>), and BAEA (n=3; 0.007/km<sup>2</sup>). The bald eagle, downlisted from its previous status of State Threatened in 2009 (MESA), is also currently included in the SSC, along with four other identified species: GBHE (n=1; 0.002/km<sup>2</sup>), LAGU (n=10; 0.038/km<sup>2</sup>), BOGU (n=397; 2.07/km<sup>2</sup>), and COTE (n=6; 0.015/km<sup>2</sup>).



Maps 24 a-e. Species of Conservation Status observed by month.



The four remaining potential species of concern may have been sighted, but due to the inability to determine the specific species, they were designated as 17 “unidentified ducks,” 15 “unidentified terns,” seven “unidentified alcids,” and six “unidentified shorebirds.” Marine mammals and other non-bird species were recorded during the surveys but none were found that are of either federal or state conservation concern at this time.

Total numbers of every species per quadrat and density, and overall count and density, was presented earlier in Table 3, with Federal and State Threatened and Endangered species denoted by red text. Table 45, below, lists all SCC in order of greatest to least, including densities, and Table 46 separates them by quadrat. The total count of avian SCC included 486 birds with BOGU comprising 81% of the SCC total. Bonaparte’s gulls were the most abundant bird species overall (Table 39d) yet third in density (2.07/km<sup>2</sup>). Unidentified ducks were the second most numerous (0.08/km<sup>2</sup>) of the SCC species and the thirteenth most common of all birds. Within the north quadrat, 33% of the total bird count consisted of SCC, 35% were in the south, and 15% were in the BR. Again, of these SCC, BOGU were the most common species within each of the individual quadrats.

Table 45. SCC from greatest to least.

SPECIES		Abund.	per km <sup>2</sup>
Bonaparte's gull	BOGU	394	2.071
unidentified duck	UNDU	17	0.080
unidentified tern	UNTE	15	0.042
laughing gull	LAGU	10	0.038
horned grebe	HOGH	10	0.034
red-throated loon	RTLO	10	0.026
unidentified alcid	UNAL	7	0.029
razorbill	RAZO	7	0.017
unidentified shorebird	SHORE	6	0.016
common tern	COTE	6	0.015
bald eagle	BAEA	3	0.007
great blue heron	GBHE	1	0.002

Table 46. SCC by quadrat.

SPECIES	NORTH	per/km <sup>2</sup>	SOUTH	per/km <sup>2</sup>	BR	per/km <sup>2</sup>
RTLO	2	0.02	8	0.06		
HOGH	10	0.10				
UNDU	11	0.14	4	0.03	2	0.07
GBHE			1	0.01		
LAGU	4	0.04	5	0.04	1	0.04
BOGU	90	0.92	199	1.43	105	3.86
COTE	1	0.01	5	0.04		
UNTE	6	0.06	9	0.06		
RAZO			7	0.05		
UNAL	6	0.08	1	0.01		
SHORE	2	0.02	4	0.03		
BAEA		0	3	0.02		
Total	132	1.4	246	1.8	108	3.97
% of All	33%		35%		15%	

Seen below, Table 47 shows the summary of these species of concern and the behaviors they were observed performing. Seven particular behavior types were observed by these SCC birds, which included the following: sitting, direct flight, milling, meandering, pattering, scavenging, and underwater pursuit diving. Of these behaviors among the SCC birds, sitting was the most common with 51% in the north quadrat, 35% in the south, and 58% in the BR. Of the flying-associated behaviors, 39% flew at five meters and the second most common height was at two meters (18%). Figure 6 provides a selection of flight heights from 10-20m that identifies species flying within the Rotor Sweep Zone. Again, only five birds were found in this zone in the north quadrat, where the risk of injury from the rotating turbine blades resides.

Table 47. Behaviors displayed by SCC in each Quadrat.

QUADRAT Behavior	NORTH							SOUTH						BR						Grand Total	
	1	20	35	48	61	65	70	1	20	35	48	61	65	1	20	35	48	61	65		
RTLO	1	1						1	6		1									10	
HOGR	10																			10	
UNDU	7	4							4						1	1				17	
GBHE									1											1	
LAGU		1	2	1				1	2	1		1			1					10	
BOGU	48	17	10	2	8	5		77	43	33	6	18	22	62	9	11	4	12	7	394	
COTE			1						3	2										6	
UNTE		1	1			4			5	1	1	1	1								15
RAZO								6	1												7
UNAL	1						5	1													7
SHORE		2							4												6
BAEA										3											3
<b>Total</b>	<b>67</b>	<b>26</b>	<b>14</b>	<b>3</b>	<b>8</b>	<b>9</b>	<b>5</b>	<b>86</b>	<b>69</b>	<b>40</b>	<b>8</b>	<b>20</b>	<b>23</b>	<b>63</b>	<b>11</b>	<b>11</b>	<b>4</b>	<b>12</b>	<b>7</b>	<b>486</b>	

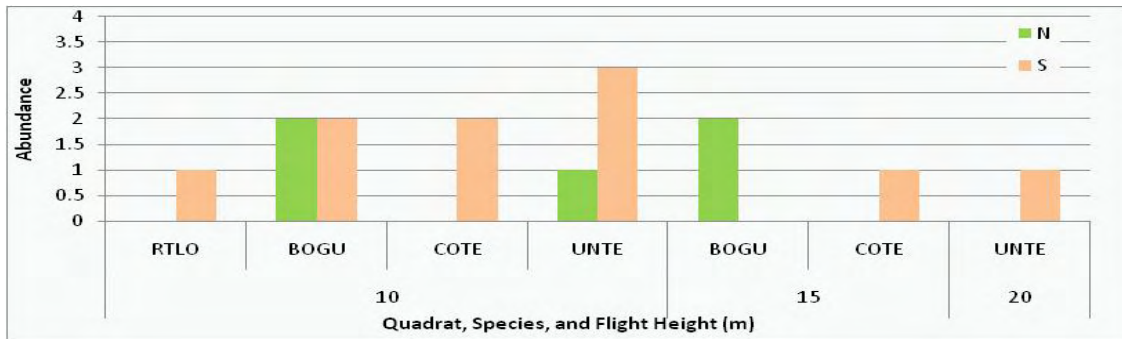


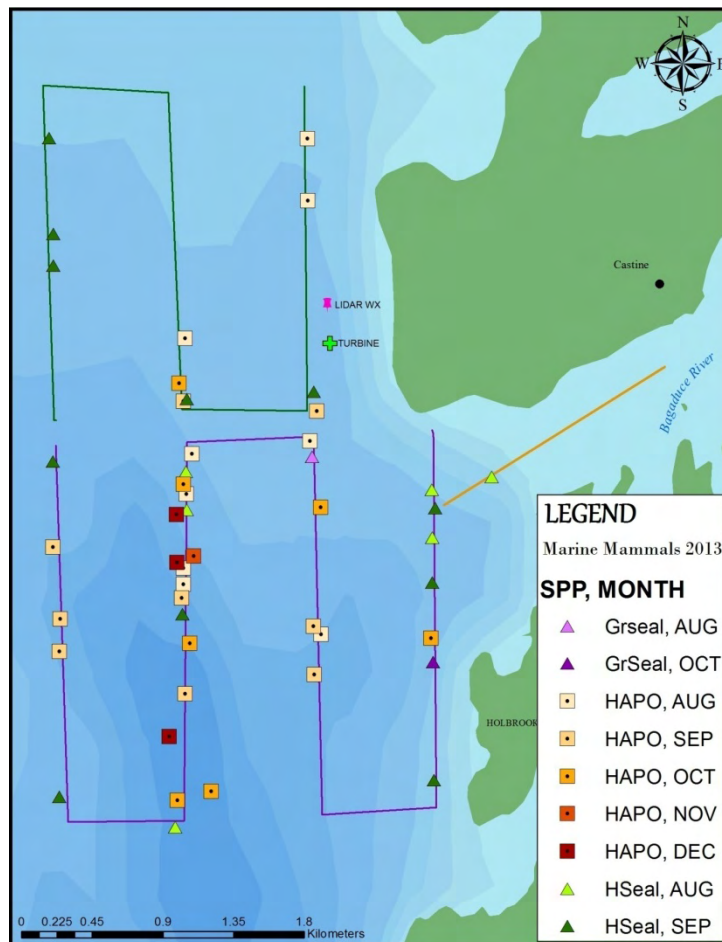
Figure 6. SCC, by quadrat, in heights within the 10-20m Rotor Sweep Zone.

## E. MARINE MAMMALS & OTHER NON-BIRD SPECIES SUMMARY

A complete list of all species observed was provided in [Table 3](#) and also in [Appendix 2](#), summarizing the species and the dates on which they were documented. No baleen whales were observed, nor fish or turtles. Of the 17 survey days, harbor seals were observed on 13 of them, totaling 0.18/km<sup>2</sup> (n=47) ([Map 25](#)). Only two gray seals were observed (0.005/km<sup>2</sup>), one each on August 14<sup>th</sup> and October 9<sup>th</sup>, and only in the south quadrat. Harbor porpoise were observed on 14 of the 17 days, totaling 0.16/km<sup>2</sup> (n=63). [Table 47](#) summarizes the seals and porpoise by quadrat. Only the harbor seals were observed in the BR, whereas all three mammal species were recorded in the south.

Table 48. Marine mammals and other non-bird species observed by date and quadrat.

QUADRAT	NORTH		SOUTH		BR		TOTAL	
	#	N/km <sup>2</sup>	#	S/km <sup>2</sup>	#	BR/km <sup>2</sup>	#	T/km <sup>2</sup>
HSeal	18	0.182	24	0.172	5	0.184	47	0.180
Gseal			2	0.010			2	0.005
HAPO	13	0.132	50	0.359			63	0.164
<b>Total</b>	<b>31</b>		<b>76</b>		<b>5</b>		<b>112</b>	



Map 25. Marine mammals and other non-bird species observed throughout the 2013 season.

## F. BOATS & BUOY OBSERVATIONS

Observations of boat traffic and lobster buoy presence were recorded during the surveys in 2013 (Map 26). A total of 71 boats were observed while surveys were performed. Two observations involved a MMA maintenance vessel attending the turbine and/or Lidar weather station, 15 were private vessels, 43 were sailboats, and the remaining 11 were lobster fishing vessels.

Figure 7 shows vessel type and numbers by quadrat. The influence of a higher number of lobster vessels ( $n^L$ ) and total boats ( $n^T$ ) in each of the quadrats may have a strong influence on the distribution and incidence of particular bird behaviors: the south  $n^L=7$  and  $n^T=37$ ; and BR quadrat  $n^L=3$ ,  $n^T=21$  compared to the north  $n^L=1$ ;  $n^T=10$ . In the south quadrat, two HERG were seen with or near a working lobster vessel and observed scavenging, as well as two RBGU also observed scavenging in the south quadrat near a lobster vessel. Six additional HERG were observed pattering (flying while foraging; code #61) directly associated with a working lobster vessel in the south quadrat as well. Only one BOGU was observed in the BR near a working lobster vessel, scavenging.

Figure 8 provides buoy numbers in each of the quadrats. A significant decrease of buoy numbers across all quadrats began in October, with buoys in the north and BR quadrats decreasing to one and four buoys, respectively, surveyed on the last date of this survey session on December 20<sup>th</sup>.

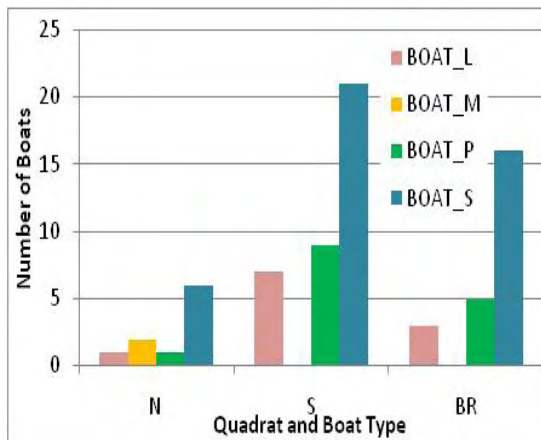


Figure 7. Boat type and location.

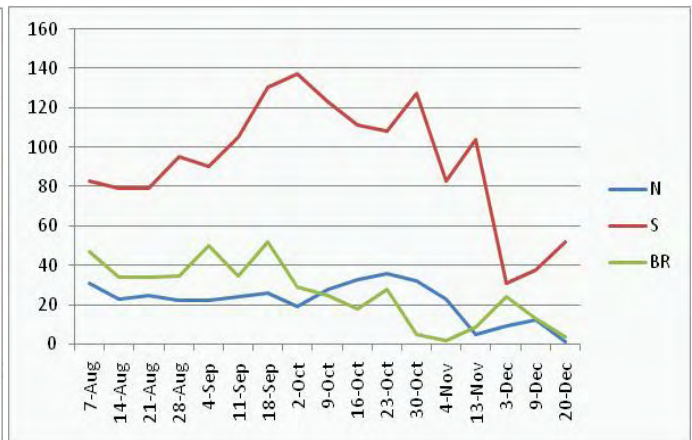
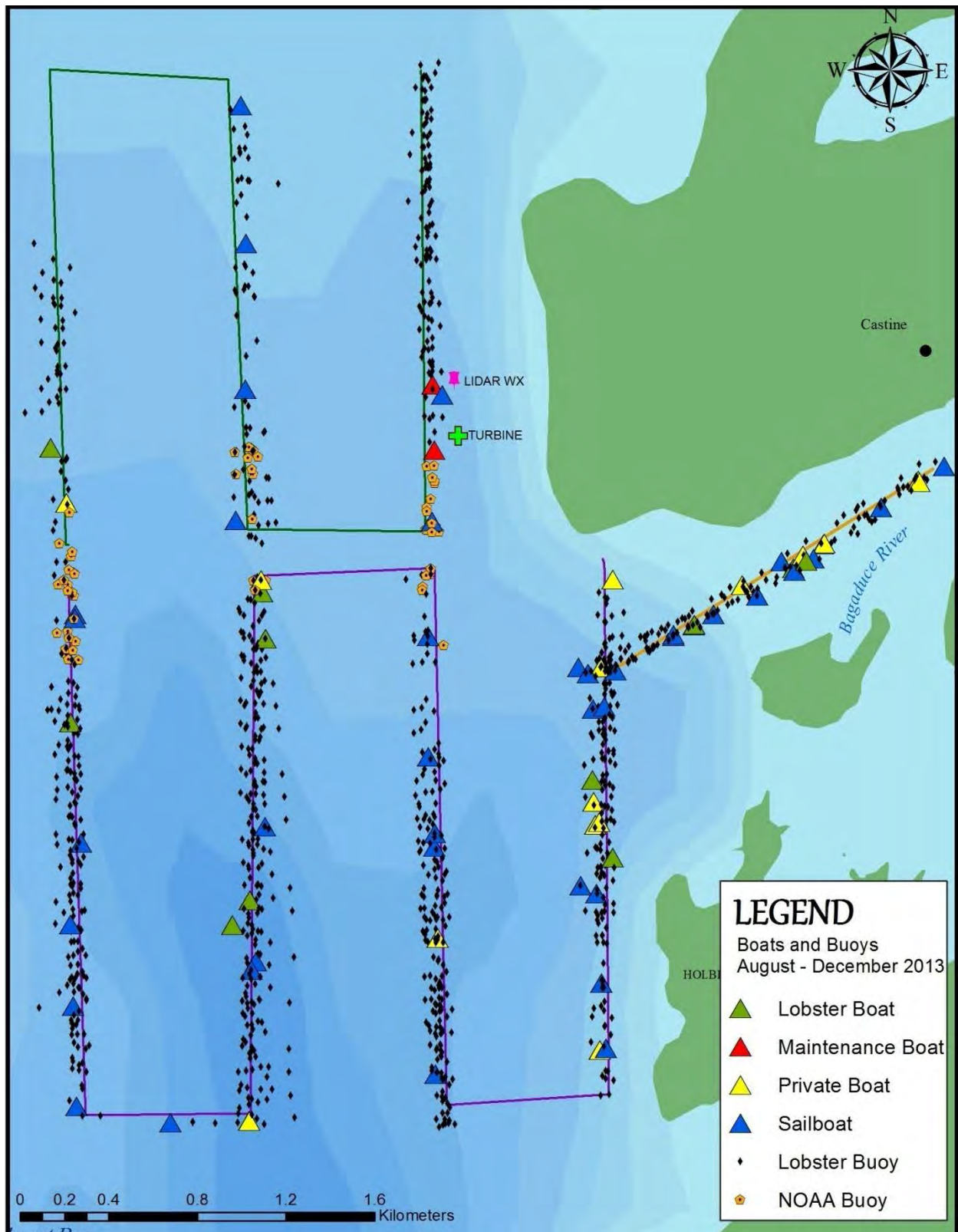


Figure 8. Buoy abundance by date and quadrat.



Map 26. Boat type and buoy abundance across the entire survey season.

## SUMMARY

August to December of 2013 included 17 boat-based visual surveys performed during the continuing deployment of the single 1/8<sup>th</sup> commercial scale VoltturnUS 20kW wind turbine on a semi-submersible floating platform at the University of Maine's Castine Harbor Dice Head Test Site. These surveys were performed at a rate of one per week during this report session, weather permitting. Data were gathered on species of birds and all other present wildlife such as marine mammals to include location, occurrence, numbers, behaviors, flight direction, and flight heights.

The previous sections of this report summarized the species numbers and activities by date and behavior categories, presented maps and tables of their sightings, and summarized species that are listed as a species of conservation designation, and other observations. Revisiting each of the project's objectives, these following sections will further summarize the highlights of this season's surveys.

### ***Objective #1: Determining bird and marine wildlife species compositions and their current activities and habitat use of the Castine Test Site.***

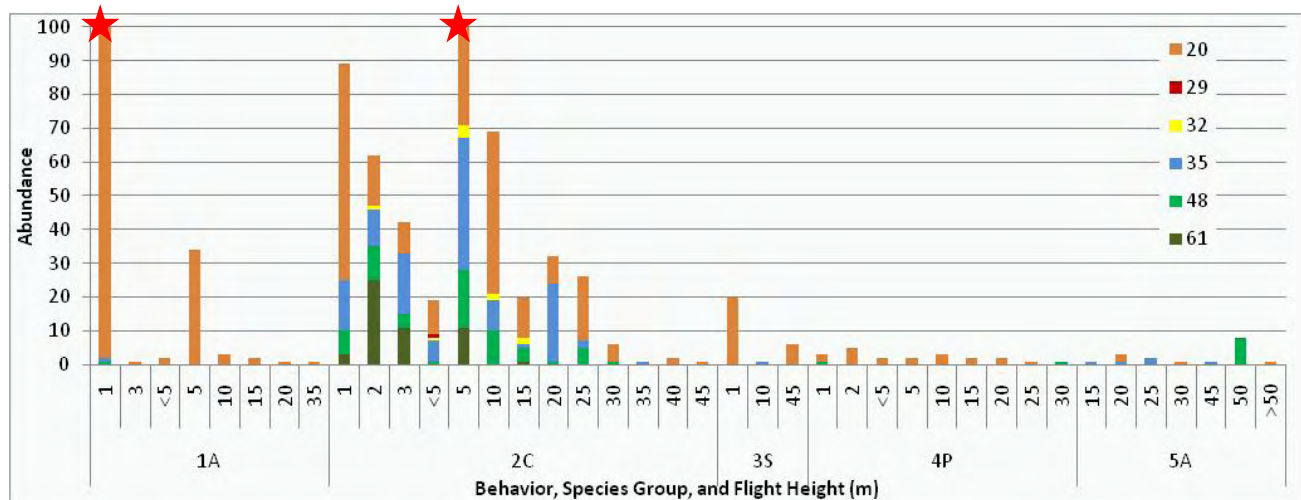
The overall count for individual birds throughout the entire Castine Test Site surveys was 1,839 and 112 marine mammals. In Part IV: Results, [Table 3](#) provided abundances, densities, and common behaviors of each survey quadrat's birds and marine mammals. Recorded in the north quadrat were a total of 23 identifiable species of birds (n=430) and two species of marine mammals (n=31). The south quadrat had 27 species of birds (n=788) and three marine mammals (n=76). The Bagaduce River quadrat had only 15 identified species of birds (n=733) and one marine mammal (n=5), but overall density was the greatest of the three quadrats.

Thirty-one identifiable species of birds were documented throughout the entire Castine Test Site. Although total abundance of each species ranked BOGU, HERG, BLGU, RBGU, and COEI as the top five species in order of greatest to lesser, densities per square kilometer show BLGU, COEI, BOGU, HERG, and RBGU listed from greatest to lesser ([Table 39d](#)). In the north and south quadrats, the top three species alternated among HERG, BOGU, and RBGU ([Tables 39 a&b](#)), but only in the BR did COEI (6.65/km<sup>2</sup>) and BLGU (6.58/km<sup>2</sup>) have the highest densities ([Table 39c](#)).

The most common avian activities observed throughout the entire Castine Test Site were sitting (49%), followed by direct flight (30%), and milling flight (7.2%). The influence of more lobster boats to total boats ratio in the south quadrat (7 : 37) compared to the BR

(3 : 21) and north quadrat (1 : 10) may have a strong influence on the distribution and sheer abundance of particular bird behaviors across the three quadrats. Particularly for Group 2: Charadriiformes, boat following, milling, and scavenging are more prevalent in the south quadrat (54%), as seen previously in [Table 44](#). Also in the south quadrat 10 gulls were observed foraging near a working lobster vessel, compared to only one incidence in the BR.

Bird Order-Groupings revealed a few notable differences among behaviors observed. Within Group 1A, 53% sat in the water and 46% flew direct, and the vast majority of the flying birds were at one meter. Group 2C represented 69% of all the species throughout the entire Castine Test Site and 50% sat in the water followed by 10% milling. Thirty percent of the flying Charadriiformes flew at five meters. Group 3S (cormorants) only either sat in the water or on a small rock in the middle of the river (43%) and the remainder flew direct or meandered from one to 45m (47%) with 45% of these fliers at one meter. Group 4P (corvids) only ever flew direct and meandered, with heights ranging from one to 30m and of those, 24% flew at two meters. Group 5A flew direct, milled, and meandered at heights from 15-50m, with 47% (consisting of eight unidentified hawks likely migrating) at 50m. [Figure 9](#) shows each species group and their typical behaviors and flight heights.



[Figure 9](#). Species group, behavior, and flight height. The red stars indicate 175 birds in 1A flying direct at one meter and 155 birds in 2C flying direct at five meters.

Endangered, threatened, and other birds of conservation status (SCC) sightings included seven razorbills (the only state threatened species) and three other identified species listed as a USFWS BCC: 10 RTLO, 10 HOG, and 3 BAEA, and MDIFW's SSC that included four other identified species: one GBHE, 10 LAGU, 394 BOGU, and six COTE. The

four remaining potential species of concern were 17 unidentified ducks, 15 unidentified terns, seven unidentified alcids, and six unidentified shorebirds. Bonaparte's gulls were the most abundant of the SCC yet ranked third in overall density. Across each quadrat, BOGU were also unanimously the most abundant species. Within the north quadrat, 33% of the total bird count consisted of SCC, 35% were in the south, and 15% were in the BR. For behaviors, the most common activity was sitting and of the flying SCC birds, 39% flew at five meters.

Seasonal variation presented potential patterns among a few species groups. As provided in [Appendix 2](#), COLO were commonly present in all but two surveys in August, and RTLO arrived only in November and continuing to be present to the end of the survey period. The duck species arrived by early November although scoter species were more numerous through October and eider numbers sharply increased by mid-October and declined to very few by December. Both HOGH and RNGR appeared only in December and were seen in small numbers through the month. Gull species were continually present, however terns and most shorebirds were present in August only. Other than BLGU that remained common throughout, alcids were present in small but distinct flocks during the last survey day in December. From the beginning of August until early November, DCCO were always present, but as expected with migration patterns, their numbers disappeared.

***Objective #2: Use on-going baseline inventory of the species composition, behaviors, and habitat use to assess potential risks to the wildlife in relation to the VoltturnUS 1/8<sup>th</sup> scale turbine at the Castine Test Site.***

Birds may experience four major types of impact caused by offshore wind farms: direct collision, displacement due to disturbance, displacement due to the barrier effect, and direct habitat loss (Drewitt & Langston 2006, Goodale & Divoll 2009). A fifth impact involves habitat enhancement due to the underwater structure acting as an artificial reef and potentially attracting piscivorous seabirds; however this can only be a net benefit if the birds are not frightened away or killed by the structure itself (Drewitt & Langston 2006). In the case of the Castine Harbor Dice Head Test Site, the 1/8<sup>th</sup> scale structure, and the data presented in this portion of the project, is relatively small in both spatial and temporal contexts. Nevertheless, discussion will follow that summarizes any potential impact that the single 20kW 1/8<sup>th</sup> scale test turbine on a floating platform may present to wildlife at the University of Maine's Castine Test Site.



Current literature discusses how the probability of impacts from wind turbines, particularly with collisions, is more dependent upon individual species and their unique behaviors (Drewitt & Langston 2006, Ferrer et al. 2012, Fox et al. 2006, Furness & Wade 2012). These considerations should also take into account the local topographic factors which influence wind patterns and prey availability, as opposed to the common investigation of local abundance (Ferrer et al. 2012); together these factors influence the behavior of the individual birds at that moment in time.

Due to the relatively light winds that blow through the upper Penobscot Bay area where the turbine is located, only seven of the 17 survey days found the blades in motion during our surveys in 2013. This minimizes the potential impact of injury or death with a swiftly moving object through the air. It is widely understood, however, that birds are documented as colliding with a wide variety of stationary man-made objects. These have included lighthouses, bridges, windows, high wires, etc., and flying birds particularly become susceptible under poor visibility and environmental conditions (Fox et al. 2006).

Flight height was determined to be a substantial factor in assessing collision probabilities by Furness & Wade in their review of Scottish seabird sensitivity to offshore wind farms (2012). It is discussed by Dierschke and Daniels that over 90% of loons, sea ducks, gulls, and terns habitually fly higher over the ocean (at or below 50m) and are more likely to be at the heights at which this turbine's blades would be spinning, thereby putting them more at risk (Dierschke & Daniels 2003 *in* Furness & Wade 2012). The single VoltturnUS 20kW wind turbine on a 1/8<sup>th</sup> commercial scale semi-submersible floating platform that was deployed on June 6, 2013 has a hub height measuring 50ft (15.24m), with a rotor diameter of 31.5ft (9.6m) and rotor sweep zone between 10-20m. For purposes of bird collision and other risks, it is necessary to consider the Castine Test Site avian flight activity in this flight height-zone, regardless of the blades spinning or not. Figure 10 provides the species and numbers that were observed flying at the heights recorded within the 10- to 20m zone; this totaled 17% of all flying birds of which 87% involved Group 2: Charadriiformes. Foragers within these heights involve 27% of the flying birds and 92% of them are again in Group 2C. From these numbers, it is possible to say that gulls are at a greater risk of collision with the VoltturnUS 1/8<sup>th</sup> scale turbine at the Castine Test Site due to their habits and greater abundance within the Rotor Sweep Zone.

As for our 12 species of conservation status, only one RTLO (of 10 total), six BOGU (of 394), three COTE (of six), and five unidentified terns (of 15) (previously, in [Figure 6](#)) were documented as flying within the rotor-sweep zone of 10- 20m above the water. This is a minimal portion of the SCC to be affected by collision with the spinning blades or its structure and therefore not of great concern.

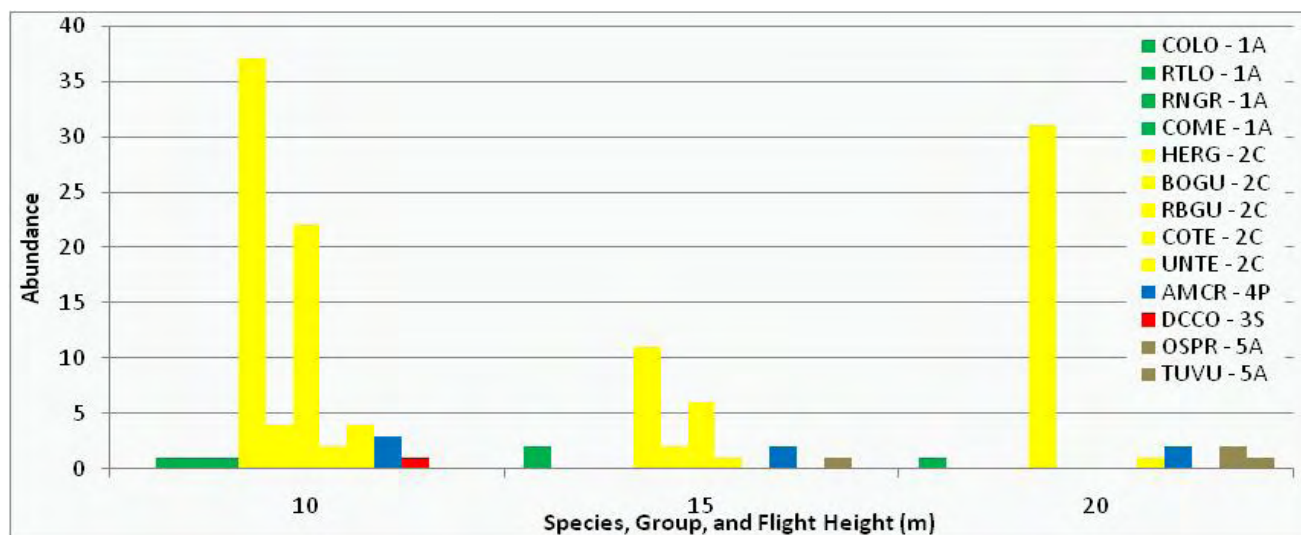


Figure 10. Species and numbers flying within the rotor-sweep zone

Numerous Wind farm Sensitivity Index (WSI) studies in Europe and North America generally agree that the species most affected by offshore wind farms include gulls, grebes, loons, seaducks, and migrating waterfowl and passerines (Drewitt & Langston 2006, Garthe & Hüppop 2004). Radar studies at a Danish location revealed significant avoidance behavior (by a factor of 4.5) within the wind farm array by geese and common eider reflected by an increase in their distance to the turbines, inadvertently reducing the risk of collision (Desholm & Kahlert 2005). A newer analysis by Furness & Wade further categorized impacts to particular species, concluding high disturbance scores for common eider, loons, and scoter species (easily disturbed, high tendency to flush); high collision impact scores for gulls, terns, and loons; and high overall disturbance and displacement scores for loons, sea ducks, and alcids (Furness & Wade 2012).

Within our survey, each species-group's potential reaction directly related to the seven days in which the turbine was spinning in the north quadrat compared to the remaining 10 days shows minimal impact. Table 49 has evaluated each species-group on the seven dates whether an obvious variation exists in the north quadrat's abundance compared to the other quadrats. A rough comparison was used to evaluate these variances. In order of severity, a rating of 1-5 will be used: "5" means the numbers show a drastic variation in the north quadrat with great potential for significant avoidance of the north quadrat; "4" has a strong potential; "3" is a small potential; "2" designates numbers equal across the quadrats and therefore no difference; and "1" means that the abundance in the north quadrat was drastically higher than any of the other quadrats, and showing an opposite effect of the aforementioned hypothesis of an avoidance behavior being displayed; and "n/a" designates that these species were not observed at all on that date throughout the entire survey area.

Table 49. Species Group and estimated relevance for positive association with spinning turbine in the north quadrat.

Turbine Spinning Dates	1A	2C	3S	4P	5A
7-Aug	n/a	4	4	n/a	1
21-Aug	n/a	3	1	n/a	3
4-Sep	1	5	3	n/a	3
4-Nov	1	4	5	2	n/a
13-Nov	5	3	n/a	1	n/a
3-Dec	2	3	n/a	n/a	n/a
9-Dec	3	3	n/a	n/a	3

Although this method is very basic and lacking statistical analysis, it offers great potential for further insight into its relevance. Of all of these species-groups, Charadriiformes has the greatest potential for showing a direct effect of the spinning turbine by reduced numbers on these specific dates in the north quadrat. Group 3: Suliformes (cormorants) show the next potential effect of reduced numbers in the north quadrat. Of these groups, the corvids (Group 4P) show an indifference, if not entirely the opposite, trend relative to the spinning turbine in which their numbers slightly increased. This does not present itself as a concern for collision because they were not obviously *attracted* anywhere near the turbine; they were always found flying due west or occasionally north, mostly on a direct flight path from the Castine mainland across the water to the Searsport or Stocton Springs vicinity of the western Penobscot Bay.

Other seasonal factors should objectively be considered in the analyses regarding behaviors of gulls, terns, sea ducks, and cormorants that are described as susceptible to disturbance by turbines (Drewitt & Langston 2006, Fox et al. 2006). With the Bagaduce River Watershed and the Holbrook Island Sanctuary in the near vicinity of this Castine Test Site, it is essential that breeding bird species are given particular consideration for their use of this “Focus Area of Ecological Significance” (BwH 2012). Of the 26 bird species from our survey that were also identified on the “Checklist of the Birds” for the Holbrook Island Sanctuary, 10 of these are known to breed in the area (Holbrook Island Sanctuary, 2001). Found in high abundance during our five surveys, HERG, BLGU, COEI, and DCCO were species that are known breeders in this location. Osprey, BAEA, GBHE, mallard, crows, and GBBG were observed in smaller numbers, but are also known breeders in this area. However, these surveys did begin August 7 and continued through late December, which is likely late enough in the breeding season to reduce the concern for these species in relation to disturbance effects by the turbine.

At a study of ecological changes at a windfarm off the shore of the Netherlands, numbers of gulls, terns, and cormorants increased as the birds actively used the area for

foraging (Lindeboom et al. 2011 *in* Furness & Wade 2012). A similar increase in gulls and terns at the Horns Rev windfarm was also documented (Petersen et al. 2004 *in* Fox et al. 2006). Although the cause was not clear regarding the increased numbers of HERG and terns at the Horns Rev wind farm in Denmark post construction (Drewitt & Langston 2006), explanation may have included increased loafing structures, increased fish abundance due to habitat modification, increased boat traffic looking like potential food sources, or a combination of any of these factors (Fox et al. 2006). For this reason, gulls in the Castine Test Site could be attracted to the turbine itself for a loafing structure, or for potentially increased foraging opportunities resulting from either increased boat traffic, or if the underwater structures and sea floor anchor disturbance create ideal habitat for fish, thereby increasing foraging piscivorous bird species (Fox et al. 2006). Fortunately, however, in these surveys, gulls, terns, and most alcids were not found to be attracted to the VoltturnUS turbine for foraging-type activities; in fact they were less numerous in general in the north quadrat than in any of the other quadrats. When separating out foraging species, the same pattern generally applies. In patterning, scavenging, and milling BOGU, densities were the least per square kilometer in the north of all the quadrats, as well as for RBGU.

Gulls are well known for investigating boats for the opportunity of finding easy food from discards (Schwemmer & Garthe 2005); this accounts for 10 gulls that were observed following our survey vessel, with three occurring in the north quadrat and seven in the south. Again, these numbers reveal a minimal cause for concern regarding the phenomenon of the turbine structure or increased human boat activity attracting these species of birds to the VoltturnUS 1/8<sup>th</sup> scale turbine.

In summary of this August to December of 2013 survey it is theoretically possible to suggest that our SCC are out of harm's way regarding direct impact due to collision or attraction due to habitat enhancement. Bonaparte's gulls, HERG, BLGU, RBGU, and COEI were recorded as the five most abundant species during our surveys (Table 38d). Of these species, when comparing our study to these previous studies, it appears that there is minimal concern regarding these species' activities near the Castine Test Site. Only due to the greater incidence of flight heights within the Rotor Sweep Zone are our gull and tern species at the most at risk for collision impacts with the structure. However, as outlined by further data, these birds showed a decreased use of the north quadrat possibly due to the spinning structure, thereby reducing the concern for collision.

The sea ducks, loons, and cormorants counted in this study totaled 476 birds at 3.8/km<sup>2</sup> over the 17 survey days. According to the literature, they are at most risk for impacts due to disturbance, attributable to being easily flushed and strongly demonstrating significant avoidance behavior of the human structures, therefore perpetuating the loss of habitat near wind farms (Furness & Wade 2012, Larsen & Guillemette 2007). This however

is a minor disturbance in our case of this small-scale Castine project, and the effects are likely minimal. As provided earlier in [Table 49](#), the potential reaction to the spinning turbine is inconclusive, if not slightly possible in creating an avoidance response in the north quadrat compared to the other quadrats for these ducks, loons, and grebes. Further detailed statistical analysis is necessary to identify the severity of this factor, however.

Although abundance alone is not a factor of concern for impact to the birds of the University of Maine's VoltturnUS 1/8<sup>th</sup> scale Test Turbine Site, the high numbers of gulls observed during this season's surveys will continue to be an interesting subset of data to observe. Due to carcasses sinking or being consumed by opportunistic predators, detection probabilities are low for birds that may be killed by collision, *if* they do occur with this single 20kW 1/8<sup>th</sup> scale floating turbine.

Maine-specific considerations for wind farm development have been suggested by the BioDiversity Research Institute to include three main criteria: 1) avoid critical breeding, wintering, and migratory areas, 2) avoid offshore islands that provide breeding areas for seabirds and are essential migratory staging areas, and 3) avoid areas within three kilometers (1.86mi) of these first two criteria to prevent serious impact to birds of special concern (Goodale & Divoll 2009). The Castine area is near the Holbrook Island Sanctuary and the Bagaduce River Watershed, renowned for its Essential Habitat status (BwH 2012) for many species of birds that include BAEA, OSPR, DCCO, and various ducks and waterfowl. Within this vicinity of the Castine Test Site, the breeding species observed during our surveys included HERG, BLGU, COEI, OSPR, BAEA, GBHE, MALL, AMCR, and GBBG. Of these birds, only three BAEA (BCC & SSC) and one GBHE (SSC) are considered a SCC and they were only ever recorded from within the south quadrat, in small numbers, and well beyond the breeding season.

In summary, it is advised that surveys continue to be performed year round and continue as long as the University of Maine's VoltturnUS floating test turbine is present. This is to best evaluate the ongoing effects and/or habituation that may occur, with particular consideration given to changes in avian species composition, abundance, and behavior that could be attributed to the presence of the test turbine. These surveys are one of the first known studies of pre-deployment species composition and behavior for an offshore floating wind turbine with a tension leg design. They are essential to an understanding of the impact of alternative energy development projects, therefore streamlining their appropriate use and cooperatively mitigating the resulting impacts will benefit both humans and seabirds within this next decade.

## **ACKNOWLEDGEMENTS**

I would sincerely like to thank Maine Maritime Academy and the dedicated captain Erin Bostrom, as well as the supporting deck hands and staff, whose accommodating spirit and generosity has made this project feasible. Additional support and mentoring is owed to Gordon Longfellow at the College of the Atlantic. The most thanks goes to Dr. Damian Brady and Donna Darling for their logistical, professional, and encouraging support. They are the catalysts that keep a worthy project afloat. Thank you.

# APPENDIX 1

## SURVEY CODES

(Gould & Forsell 1989)

### Code 2. Survey Type (15)

- 1 = General observations: These are records of large flocks, rare or unusual sightings, transects that cannot be used to derive density indexes, or any record that will not fit another format.
- 7 = Station count: The criteria for a station count are that the platform is stationary and that all birds are counted in a 360° circle from the platform.
- 9 = Ocean transect: The criteria for a transect are a visibility of at least 1,000m and a moving platform with a constant speed and direction. An oceanic-transect is conducted outside well-defined headlands.

### Code 3. Observation Conditions (75)

- 1 = Bad (general observations only)
- 2 = Poor (no quantitative analysis)
- 3 = Fair
- 4 = Average
- 5 = Good
- 6 = Excellent
- 7 = Maximum

### Code 5. Sea State (49)

- 0 = Calm
- 1 = Rippled (0.0 1-0.25 ft)
- 2 = Wavelet (0.26-2.0 ft)
- 3 = Slight (2-4 ft)
- 4 = Moderate (4-8 ft)
- 5 = Rough (8-13 ft)
- 6 = Very rough (13-20 ft)
- 7 = High (20-30 ft)
- 8 = Over 30 ft

### Code 6. Weather (55-56)

- 00 = Clear to partly cloudy (0-50% cloud cover)
- 03 = Cloudy to overcast (51-100% cloud cover)
- 41 = Fog (patchy)
- 43 = Fog (solid)
- 68 = Rain
- 71 = Snow
- 87 = Hail

### Code 14. Age (32)

- P = Pullus (flightless young)
- J = Hatching year (hatching date to spring molt: a bird capable of sustained flight)
- S = Subadult (last year before adult plumage)
- A = Adult

### Code 17. Bird Behavior (56-57)

- 00 = Undetermined
- 01 = Sitting on water
- 10 = Sitting on floating object
- 15 = Sitting on land
- 20 = Flying in direct & consistent heading
- 29 = Flying, height variable
- 31 = Flying, circling ship
- 32 = Flying, following ship
- 34 = Flying, being pirated
- 35 = Flying, milling or circling (foraging)
- 48 = Flying, meandering
- 61 = Feeding at or near surface while flying (dipping or pattering)
- 65 = Feeding at surface (scavenging)
- 66 = Feeding at or near surface, not diving or flying (surface seizing)
- 70 = Feeding below surface (pursuit diving)
- 71 = Feeding below surface (plunge diving)
- 82 = Feeding above surface (pirating)
- 90 = Courtship display
- 98 = Dead

### Code 18. Mammal Behavior (56-57)

- 00 = Undetermined
- 01 = Leaping
- 02 = Feeding
- 03 = Mother with young
- 04 = Synchronous diving
- 05 = Bow riding
- 06 = Porpoising
- 07 = Hauled out
- 08 = Sleeping
- 09 = Avoidance
- 14 = Curious/following
- 15 = Cetacea/pinniped association
- 16 = Pinniped/bird association
- 17 = Cetacea/bird association
- 18 = Breeding/copulation
- 19 = Moribund/dead

## APPENDIX 2. Species abundances by date.

2013		August				September			October					November		December			Total
Common Name	Scientific Name	7-Aug	14-Aug	21-Aug	28-Aug	4-Sep	11-Sep	18-Sep	2-Oct	9-Oct	16-Oct	23-Oct	30-Oct	4-Nov	13-Nov	3-Dec	9-Dec	20-Dec	
common loon	<i>Gavia immer</i>		1		2	3	1	4	1	5	5	7	6	3	4	2	6	9	59
red-throated loon	<i>Gavia stellata</i>													2	4	1	1	2	10
common eider	<i>Somateria mollissima</i>		1								2	53	29		103	1	1	3	193
surf scoter	<i>Melanitta perspicillata</i>							2		11		1			1				15
white-winged scoter	<i>Melanitta fusca</i>									10		19						8	37
unidentified scoter	<i>Melanitta sp.</i>									8						3			11
horned grebe	<i>Podiceps auritus</i>															10			10
red-necked grebe	<i>Podiceps grisegena</i>															1	3	13	17
bufflehead	<i>Bucephala albeola</i>														4				4
long-tailed duck	<i>Clangula hyemalis</i>												22	1	18	32	2	5	80
mallard	<i>Anas platyrhynchos</i>																18		18
common merganser	<i>Mergus merganser</i>															1			1
red-breasted	<i>Mergus serrator</i>																3		3
unidentified duck										1	2		1		4	2		7	17
great blue heron	<i>Ardea herodias</i>						1												1
great black-backed	<i>Larus marinus</i>																1		1
herring gull	<i>Larus argentatus</i>	3	17	2	12	20	22	26	17	12	40	27	26	6	9	50	42	19	350
laughing gull	<i>Larus atricilla</i>	1			1	5			3										10
black-legged kittiwake	<i>Rissa tridactyla</i>									5							1	1	7
Bonaparte's gull	<i>Larus philadelphia</i>	5		34	14	19	9	91	13	84	3	35	12	5	3	10	18	39	394
ring-billed gull	<i>Larus delawarensis</i>	10	2	22	27	14	36	30	38	11		5	7	1		21	2	1	227
common tern	<i>Sterna hirundo</i>	1	3		2														6
unidentified tern	<i>Sterna sp.</i>	3	5	7															15
black guillemot	<i>Cephus grille</i>	6	19	5	39	9		16	11	22	20	26	13	7	22	17	9	7	248
razorbill	<i>Alca torda</i>																	7	7
unidentified alcid				1	1													5	7
unidentified shorebird			5							1									6
American crow	<i>Corvus brachyrhynchos</i>							2	4	2			2	8	2				20
common raven	<i>Corvus corax</i>													1					1
double-crested	<i>Phalacrocorax auritus</i>	6	7	2	6	6	4	1	2	1	4	1	1	6					47
bald eagle	<i>Haliaeetus leucocephalus</i>													1			2		3
osprey	<i>Pandion haliaetus</i>	2		1															3
unidentified hawk								9		1									10
turkey vulture	<i>Cathartes aura</i>							1											1
<b>Bird Total</b>		<b>37</b>	<b>60</b>	<b>74</b>	<b>104</b>	<b>76</b>	<b>73</b>	<b>182</b>	<b>89</b>	<b>174</b>	<b>76</b>	<b>174</b>	<b>119</b>	<b>41</b>	<b>174</b>	<b>151</b>	<b>109</b>	<b>126</b>	<b>1839</b>
harbor seal	<i>Phoca vitulina</i>		3	1	2	1	1	9		7	2	10	8	1	1	1			47
gray seal	<i>Halichoerus gypus</i>		1							1									2
harbor porpoise	<i>Phocoena phocoena</i>	1	7	3	6	5	3	15	2	1	6		5		4		3	2	63
<b>Marine Mammal Total</b>		<b>1</b>	<b>11</b>	<b>4</b>	<b>8</b>	<b>6</b>	<b>4</b>	<b>24</b>	<b>2</b>	<b>9</b>	<b>8</b>	<b>10</b>	<b>13</b>	<b>1</b>	<b>5</b>	<b>1</b>	<b>3</b>	<b>2</b>	<b>112</b>



## LITERATURE CITED

- Beginning With Habitat. (2012) "Focus Areas of Statewide Ecological Significance: Bagaduce River," 5 pp. [http://www.maine.gov/doc/nrimc/mnap/focusarea/bagaduce\\_river\\_focus\\_area.pdf](http://www.maine.gov/doc/nrimc/mnap/focusarea/bagaduce_river_focus_area.pdf)
- Berleant, A. "\$1 million grant for Bagaduce River arrives with strings attached." *Castine Patriot*, April 5, 2012.
- Biodiversity Research Institute (2012). "Birds, Bats, and Coastal Windfarm Development in Coastal Maine: Preliminary Ranking of Bird Use." *Biodiversity Research Institute*. Retrieved July 29, 2012, from <http://www.briloon.org/oae/the-science-of-bri/tracking-wildlife/birds-bats-costal-windfarm-development>
- Drewitt, A.L. and R.H.W Langston. 2006. Assessing the impacts of wind farm on birds. *Ibis* 148: 29-42.
- Ferrer, M., M. de Lucas, G.F.E. Janss, E. Casado, A.R. Muñoz, M.J. Bechard, and C. P. Calabuig. 2012. Weak relationship between risk assessment studies and recorded mortality in wind farms. *Journal of Applied Ecology* 49: 38-46.
- Fox, A.D. M. Desholm, J. Kahlert, T. K. Chritensen, I.B.K. Petersen. 2006. Information needs to support environmental impact assessment of the effects of European marine offshore wind farms on birds. *Ibis* 148: 129-144.
- Furness, B. & H. Wade. 2012. Vulnerability of Scottish Seabirds to Offshore Wind Turbines. MacArthur Green Ltd., Glasgow. 39pp.
- Garthe, S. and O. Hüppop. 2004. Scaling possible adverse effects of marine wind farms on seabirds: developing and applying a vulnerability index. *Journal of Applied Ecology* 41: 724-734.
- Goodale, W. and T. Divoll. 2009. Birds, Bats and Coastal Wind Farm Development in Maine: A Literature Review. Report BRI 2009-18. BioDiversity Research Institute, Gorham, Maine.
- Gould, P.J. & D.J. Forsell. 1989. Techniques for shipboard surveys of marine birds. U.S. Fish & Wildlife Service, *Fish & Wildl. Technical Report* 25, 22 pp.
- Kennedy, L. & Holberton, R.L. 2012. "Visual Observations for Birds, Turtles, and Marine Mammals at the University of Maine Test Site off Monhegan Island, a report submitted to the Maine State Planning Office and University of Maine." Submitted January 2012. 52pp.
- Larsen, J.K. and M. Guillemette. 2007. Effects of wind turbines on flight behaviour of wintering common eiders: implications for habitat use and collision risk. *Journal of Applied Ecology* 44: 516-522.
- Maine's Department of Inland Fisheries & Wildlife (MDIFW) Endangered Species Program/Bird List [http://www.maine.gov/ifw/wildlife/species/endangered\\_species/bird\\_list.htm](http://www.maine.gov/ifw/wildlife/species/endangered_species/bird_list.htm)
- MDIFW Species of Special Concern. (<http://www.maine.gov/ifw/wildlife/endangered/specialconcern.htm#birds>)

- Maine Tidal Power Initiative's Site Resource Assessment (2011). Published Habitat Map: Bagaduce Narrows and Castine Harbor, Maine. "Significant Wildlife and Essential Habitats." *University of Maine: Maine Tidal Power Initiative*. Retrieved from the Maine DEP website: [http://www.maine.gov/dep/gis/datamaps/index.html#nrpa\\_bird](http://www.maine.gov/dep/gis/datamaps/index.html#nrpa_bird)
- Schwemmer, P. and S. Garthe. 2005. At-sea distribution and behavior of a surface-feeding seabird, the lesser black-backed gull *Larus fuscus*, and its association with different prey. *Marine Ecology Progress Series*. 285: 245-258.
- Tasker, M.L., P.H. Jones, T. Dixon, & B.F. Blake. 1984. Counting seabirds at sea from ships: A review of methods employed and a suggestion for a standardized approach. *The Auk* 101: 567-577.
- USFWS Species of Conservation Concern 2008 (U.S. Fish and Wildlife Service. 2008. Birds of Conservation Concern 2008. United States Department of Interior, Fish and Wildlife Service, Division of Migratory Bird Management, Arlington, Virginia. 85 pp. [Online version available at <https://www.fws.gov/migratorybirds/NewReportsPublications/SpecialTopics/BCC2008/BCC2008.pdf>]
- USFWS (January 9, 2012). **Guidance regarding use of the Wind Turbine Guidelines Advisory Committee's recommendations.** *Wind Turbine Guidelines Advisory Committee: Habitat and Resource Conservation*. Retrieved September 23, 2012, from [http://www.fws.gov/habitatconservation/windpower/wind\\_turbine\\_advisory\\_committee.html](http://www.fws.gov/habitatconservation/windpower/wind_turbine_advisory_committee.html)

# Visual Observations for Birds, Turtles, and Marine Mammals at the University of Maine Test Site near Castine, Maine.



*A report submitted to the University of Maine's Advanced Structures  
and Composites Center*

*JANUARY – MAY 2014*

*by*

**LAURA KENNEDY, MS**

*Lubird Kennedy Environmental Services*

Bar Harbor, Maine

[lubirdkennedy@yahoo.com](mailto:lubirdkennedy@yahoo.com)

918-549-5625

# TABLE OF CONTENTS

Executive Summary .....	1
I. Introduction .....	2
II. Location.....	4
III. Methods.....	7
IV. JANUARY – MAY 2014 Results.....	10
A. Surveys by day .....	14
1. January 15 Survey, afternoon.....	14
2. January 29 Survey, morning .....	15
3. February 6 Survey, afternoon.....	17
4. February 25 Survey, afternoon.....	18
March 3 Survey, afternoon.....	20
6. March 19 Survey, morning .....	21
7. April 6 Survey, morning .....	23
8. April 9 Survey, afternoon .....	24
9. April 18 Survey, morning .....	26
10. April 29 Survey, afternoon .....	27
11. May 8 Survey, afternoon .....	29
12. May 15 Survey, morning .....	30
13. May 22 Survey, morning .....	32
14. May 28 Survey, morning .....	33
B. Species Abundance and Diversity.....	35
C. Bird Behavior Categories.....	37
1. Sitting .....	37
2. Flying Behaviors .....	37
a. Direct Flight Behavior .....	37
b. Milling Flight Behavior.....	38
c. Meandering Flight Behavior .....	39
3. Foraging & Other Behaviors .....	39
D. Endangered, Threatened, and Birds of Conservation Status.....	41
E. Marine Mammals .....	44
F. Boats & Buoys .....	45
VI. Summary .....	46
A. Objective #1 .....	47
B. Objective #2 .....	50
VII. Acknowledgements .....	55
VIII. Literature Cited .....	58

## TABLES:

Table 1. Most common behavior codes .....	9
Table 2. Surveys by time of day and corresponding weather conditions .....	10
Table 3. Species codes, scientific names, and densities.....	11
Table 4. Species of conservation concern designation .....	12
Table 5. Number of species Jan 15.....	14
Table 6. Species by quadrat, behavior, and height, Jan 15 .....	14
Table 7. Number of species Jan 29.....	15
Table 8. Species by quadrat, behavior, and height, Jan 29 .....	15
Table 9. Number of species Feb 6 .....	17
Table 10. Species by quadrat, behavior, and height, Feb 6 .....	17

Table 11.	Number of species Feb 25 .....	18
Table 12.	Species by quadrat, behavior, and height, Feb 25 .....	18
Table 13.	Number of species Mar 3 .....	20
Table 14.	Species by quadrat, behavior, and height, Mar 3 .....	20
Table 15.	Number of species Mar 19 .....	21
Table 16.	Species by quadrat, behavior, and height, Mar 19 .....	21
Table 17.	Number of species Apr 6 .....	23
Table 18.	Species by quadrat, behavior, and height, Apr 6 .....	23
Table 19.	Number of species Apr 9 .....	24
Table 20.	Species by quadrat, behavior, and height, Apr 9 .....	24
Table 21.	Number of species Apr 18 .....	26
Table 22.	Species by quadrat, behavior, and height, Apr 18 .....	26
Table 23.	Number of species Apr 29 .....	27
Table 24.	Species by quadrat, behavior, and height, Apr 29 .....	27
Table 25.	Number of species May 8 .....	29
Table 26.	Species by quadrat, behavior, and height, May 8 .....	29
Table 27.	Number of species May 15 .....	30
Table 28.	Species by quadrat, behavior, and height, May 15 .....	30
Table 29.	Number of species May 22 .....	32
Table 30.	Species by quadrat, behavior, and height, May 22 .....	32
Table 31.	Number of species May 28 .....	33
Table 32.	Species by quadrat, behavior, and height, May 28 .....	33
Table 33a-d.	Species abundances from greatest to lesser, total area and by quadrats .....	35
Table 34.	Species by quadrat, behavior, and height, Feb 6 .....	37
Table 35.	Species of Conservation Concern flying behaviors and heights .....	43
Table 36.	Marine mammals by date and quadrat .....	44

## MAPS:

Map 1.	Castine and Penobscot Bay in Maine with survey tracks .....	2
Map 2.	Location of the Castine Test Site .....	3
Map 3.	Bagaduce River Watershed .....	5
Map 4.	New England Tidal Power Initiative Map of Significant Wildlife and Essential Habitats .....	6
Map 5.	Castine Test Site survey track lines .....	8
Map 6.	Jan 15 observations .....	16
Map 7.	Jan 29 observations .....	16
Map 8.	Feb 6 observations .....	19
Map 9.	Feb 25 observations .....	19
Map 10.	Mar 3 observations .....	22
Map 11.	Mar 19 observations .....	22
Map 12.	Apr 6 observations .....	25
Map 13.	Apr 9 observations .....	25
Map 14.	Apr 18 observations .....	28
Map 15.	Apr 29 observations .....	28
Map 16.	May 8 observations .....	31
Map 17.	May 15 observations .....	31
Map 18.	May 22 observations .....	34
Map 19.	May 28 observations .....	34
Map 20a-e.	Bird abundance by month .....	36
Map 21.	Foraging birds throughout the season .....	40
Map 22.	Species of Conservation Concern throughout the season .....	42
Map 23.	Marine mammals throughout the season .....	46

Map 24.	Boats and buoys .....	46
Map 25.	Birds flying within the Rotor-Sweep Zone (10-20m) .....	52

## FIGURES:

Figure 1.	Direct flight heights by Order-Group.....	38
Figure 2.	Species numbers and flight height in Milling flight .....	38
Figure 3.	Species numbers and flight height in Meandering flight.....	39
Figure 4.	All foraging flight heights by quadrat .....	40
Figure 5.	Species of Conservation Concern behaviors.....	43
Figure 6.	Numbers of lobster buoys by quadrat and date.....	45
Figure 7.	Bird Order-Group abundances by date .....	48
Figure 8.	All flight heights.....	48
Figure 9.	Behavior types by Order-Group .....	49

## APPENDICES:

Appendix 1: Behavioral codes (Gould & Forsell 1989) .....	56
Appendix 2: Species code, scientific name, dates, abundances, and densities.....	57

## **Public Use Statement**

This report contains data collected through federal funds provided by the University of Maine's Advanced Structures and Composites Center (Ct-07B-20111024\*2017). While the information provided in this report is meant for public access, permission is required to reproduce figures, tables, and any other product contained within this report without the express permission of the University of Maine's Advanced Structures and Composites Center.

Suggested citation for this report:

Kennedy, L. 2014b. "Visual Observations for Birds, Turtles, and Marine Mammals at the University of Maine Test Site near Castine, Maine; January – May 2014. A report submitted to the University of Maine's Advanced Structures and Composites Center. "

## Executive Summary

Fourteen boat-based surveys were conducted from January to May 2014 at the University of Maine's Castine Harbor Dice Head Test Site near Castine, Maine. The primary objective is to record baseline pre-deployment observations of seabirds and other wildlife at this location. Observations included species, number, behavior, flight height and direction, as well as weather and sea conditions. The secondary objective is to use this information to assess potential risk or behavior conflicts that may occur due to the presence of the VoltturnUS 20kW wind turbine on a 1/8th commercial scale floating platform and its operations and maintenance.

Throughout these 14 surveys in 2014, 734 birds were recorded and 25 marine mammals. The four most prevalent bird species were common eider (*Somateria mollissima*; n=101, 6.5/km<sup>2</sup>), herring gull (*L. argentatus*, HERG; n=97, 6.2/km<sup>2</sup>), common loon (*Gavia immer*, COLO; n= 85, 5.4/km<sup>2</sup>, and black guillemot (*Cepphus grille*, BLGU; n=85, 5.4/km<sup>2</sup>). Razorbills (*Alca torda*) were the only identified state-threatened species of concern (n=22, 1.4/km<sup>2</sup>) as well as two peregrine falcons (state-endangered) (0.13/km<sup>2</sup>) in the area. Eight other identified species or potential species of concern with a USFWS or MDIFW conservation designation were recorded such as bald eagles (*Haliaeetus leucocephalus*; BAEA), unidentified ducks, and other alcids.

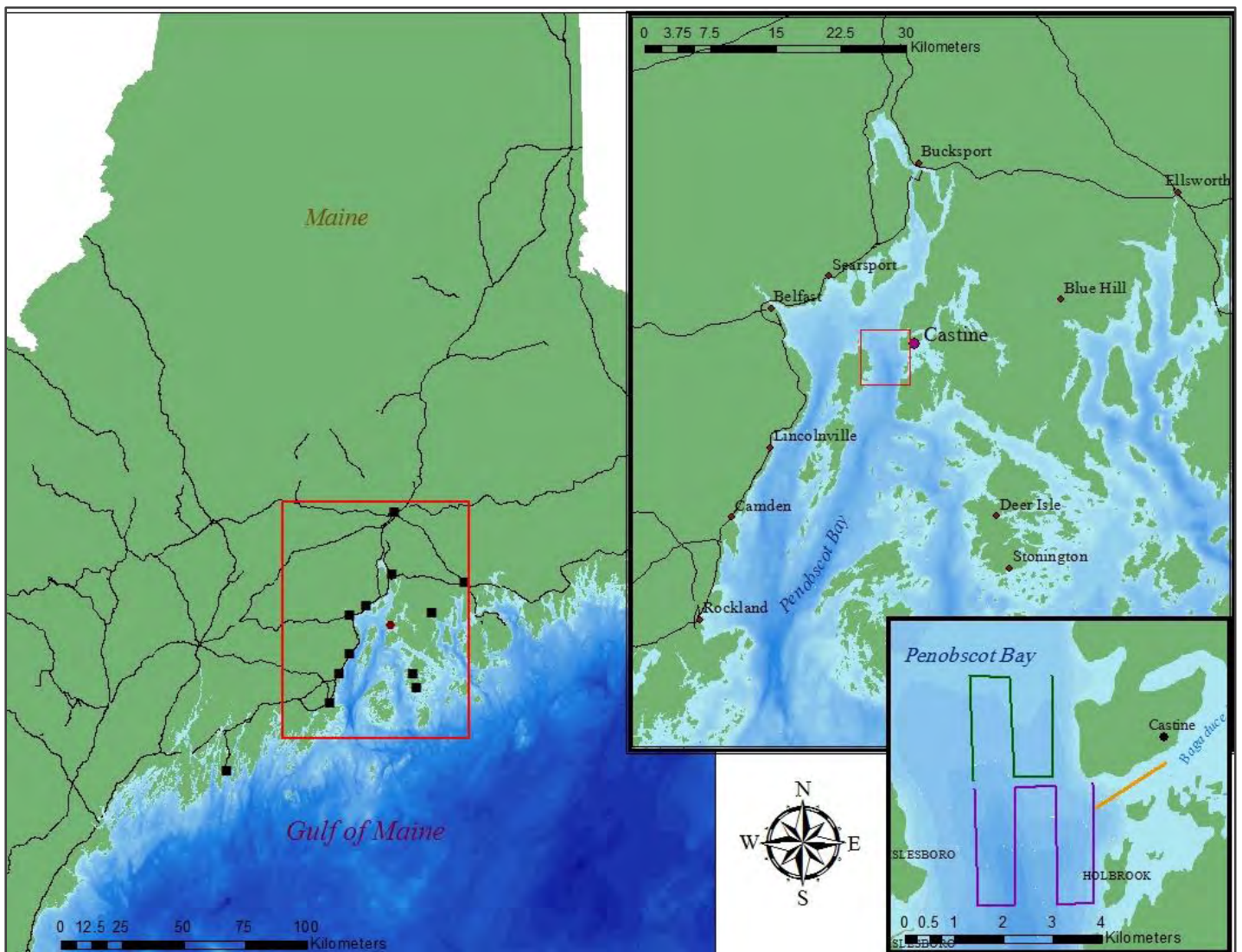
The most common bird behaviors included sitting on the water (31% were COEI and 27% were COLO), direct flight (29% were COEI and 21% were LTDU), and underwater foraging (50% were LTDU and 25% were DCCO). Of the flying birds, 73% flew at one meter, and 13% flew at the next common height of two meters. Among the birds of a conservation concern designation (SCC), sitting on the water was the most common with 57% followed by direct flight (30%). Ninety-two percent of flying-associated behaviors by these SCC were at or below five meters, well under the danger of spinning blade collisions.

Although the test turbine is small-scale, gulls and ducks may have the greatest potential for impact due to higher abundances in the area and flight heights more commonly found within the Rotor Sweep Zone (RSZ) of 10-20m. Within this zone, all flying bird species comprised 35%, of which 53% involved Group 1: Anseriformes yet only 12% of these flew within the RSZ. Actively foraging birds within the RSZ involved 62% of all birds but only six percent were located in the north quadrat where the turbine is located. Of the 10 total SCC, only one BAEA and one laughing gull (*L. atricilla*) flew within the RSZ. From these numbers, the impact due to direct collision or loss of habitat attributed to avoidance by bird species appears to be very minimal during this time of year.



# I. INTRODUCTION

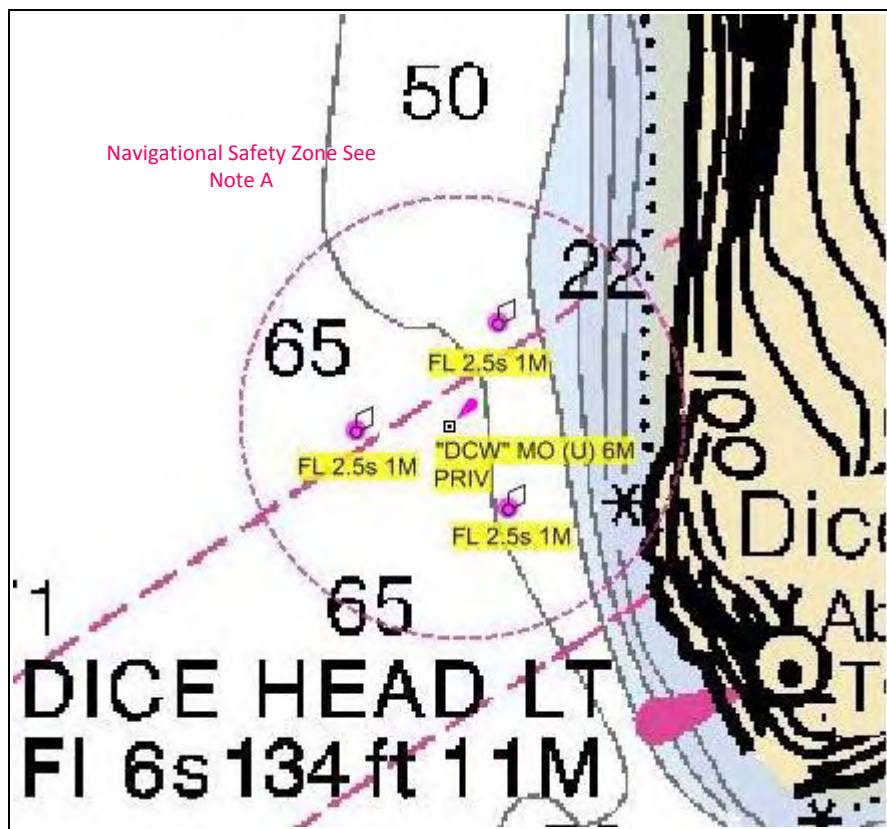
The Gulf of Maine (GOM) is a well-known avian corridor for the millions of songbirds, raptors, shorebirds, wading birds, and waterfowl to pass through during the spring and fall migration (Goodale & Divoll 2009). Over 300 documented species of all major avian taxa frequent the GOM region and more data is currently being accumulated that supports a growing list of known-wintering species. For the purposes of this report, our area of focus lies near Castine, ME midway along Maine's coast at the mouth of the Penobscot River, in Penobscot Bay (Map 1).



Map 1. Castine and Penobscot Bay in Maine, with survey region inside the smaller red box in inset maps.

This survey was initiated as a request for pre- and during-deployment data at the Castine Test Site to be used in the environmental assessment for DeepCwind’s VoltturnUS 1/8 scale turbine test unit on a semi-submersible floating platform. Specific information pertaining to the flight heights, behaviors, and species found near the Dice Head Lighthouse area helps to better understand the birds’ habitat use of the site (e.g., feeding, resting, and passing through the area). It also helps to assess potential risks as a result of human activities associated with the siting, construction, operation, and removal of turbine structures. Resource agencies such as the Maine Department of Inland Fisheries and Wildlife (MDIFW) and the United States Fish and Wildlife Service (USFWS) consider monitoring bird activity with respect to offshore wind development a high priority (USFWS Wind Turbine Guidelines Advisory Committee, 2012).

The location of the VoltturnUS 1/8th scale semi-submersible floating platform turbine is found at N44°23’8”, W68° 49’ 32” in the waters 1,000ft (305m) off Dice’s Head at Castine, Maine, in an existing cableway (Map 2).



Map 2. Location of Castine Test Turbine Site near Castine, Maine. Map courtesy of University of Maine’s Navigation Safety Plan, D.Chase.

The primary objectives of this study include 1) determining bird and marine wildlife species compositions and their current activities and habitat use of the Castine Harbor Dice Head Test Site, and 2) using this information to assess potential risk or behavior conflicts that may occur due to the presence of the University of Maine's VoltturnUS 20kW wind turbine on a 1/8<sup>th</sup> commercial scale floating platform and its operations and maintenance. Data will assess species composition and behavior changes, if any, to the presence of the structure. These risks will include potential collision with both above and below surface structures such as blades and platform anchoring lines, or the use of the platform structure for wildlife to roost upon. Other potential behavioral conflicts may arise due to the operational boat traffic and other sources of increased human presence, or additional structure presence.

This report summarizes ongoing baseline data of the VoltturnUS turbine's deployment at the University of Maine's Castine Test Site that occurred as of June 6, 2013. The structure consists of a single 20 kW test turbine that measures 20m tall (65.6ft) at the highest blade tip, sitting on a floating tension leg platform and connects to the electric grid via an underwater cable. The rotor diameter measures 31.5ft (9.6m), creating a Rotor Sweep Zone (RSZ) from 10m to 20m from the water's surface.

## II. LOCATION

Castine lies on the west side of the Blue Hill peninsula and on the north-west bank of the Bagaduce River, which is a 12-mile (19.3km) stretch of flowing tidal water that converges into Penobscot Bay. The BioDiversity Research Institute ([www.briloon.org](http://www.briloon.org)) has created a Ranking of Bird Use map that categorizes areas from High to Low bird use. The numerous islands that lie at the outer edge of Penobscot Bay, particularly on the tip of the Blue Hill Peninsula, have a concentrated zone of High bird use. Further up the bay, however, near Castine and in the area surveyed in this report, bird use rates as "Low" (BRI, 2012).

Two important areas of this region of the Blue Hill Peninsula and Penobscot Bay are considered "Significant Wildlife Areas": the Bagaduce River watershed and Holbrook Island Sanctuary.

Like the GOM region, the Penobscot Bay region contains important and diverse ecosystems for many species of birds, invertebrates, fish, and shellfish, largely due to the Bagaduce River's ecological significance (Map 3). Because of this abundance of wildlife and habitat, the Bagaduce River Watershed has been designated by the Beginning with Habitat (BwH) organization ([www.beginningwithhabitat.org](http://www.beginningwithhabitat.org)) as a "Focus Area of Statewide

Ecological Significance” that includes Significant Wildlife Areas for Inland Wading Bird and Waterfowl Habitat, Tidal Wading bird and waterfowl habitat, and Significant Shorebird Area (BwH, 2012). Map 3 shows the location of the VoltturnUS 1/8<sup>th</sup> scale floating test turbine site, which is not inside the Bagaduce River watershed, but is in the vicinity.



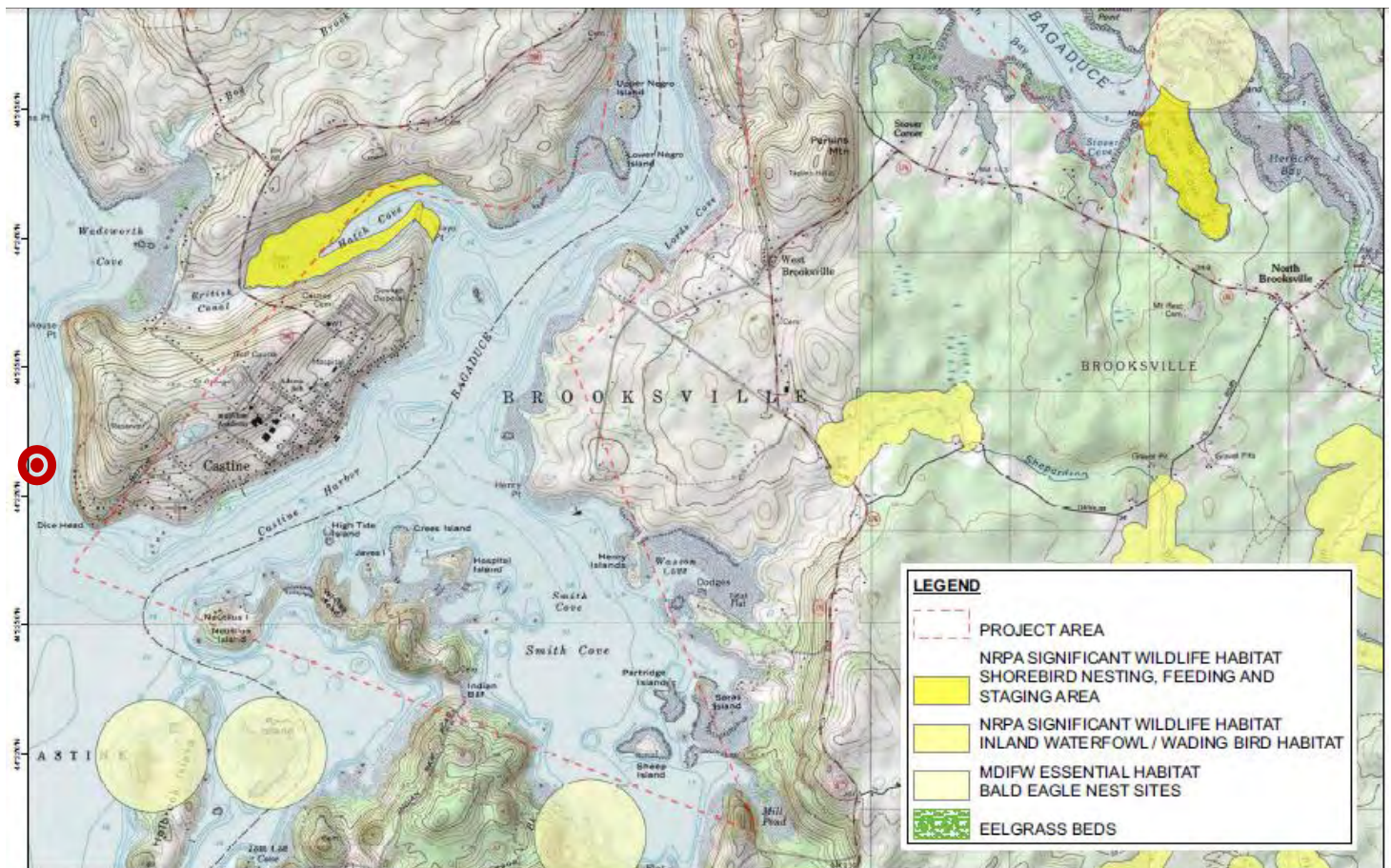
Map 3. The Bagaduce River Watershed. Map courtesy of *Beginning With Habitat* ([www.beginningwithhabitat.org](http://www.beginningwithhabitat.org)). The purple circle represents the Castine Harbor Dice Head Turbine Test site location.

Not only is the area of the Bagaduce River’s 2,700 acres available for waterfowl and wading birds’ feeding, breeding, and migratory stopover, but it is also one of a few locations in Maine where American horseshoe crabs (*Limulus polyphemus*) are known to breed (BwH, 2012). In April of 2012, the Maine Coast Heritage Trust received a large federal matching grant to further wetland habitat conservation and land protection efforts in the Bagaduce River watershed due to its important bird habitat status (Berleant 2012). Due to the shallow open waterways and strong tides that help resist freezing in the winter, migrating and wintering waterfowl take refuge in the protected coves of the river.

In a collaborative effort with the University of Maine, the Maine Tidal Power Initiative’s Site Resource Assessment (MTPI, 2012) has located specific coves and marshes that provide “NRPA Significant Wildlife Habitat for Shorebird Nesting, Feeding, and Staging Areas” as well as for “Inland Waterfowl & Wading Bird Habitat” within the Bagaduce River’s pathway. As seen in Map 4, the nearest significant habitats to the proposed Castine Harbor Dice Head Test Turbine location are some eel grass beds located in Wadsworth Cove (green patches), a large shorebird nesting, feeding and staging area in Hatch Cove

(yellow area), and two tan circles south of Dice Head that represent previously-known Bald eagle (*Haliaeetus leucocephalus*; BAEA) nest sites, circa 2012.

The Bagaduce River watershed is a key wildlife corridor for these species, as well as a provider of healthy and diverse economic resources for humans such as harboring natural nurseries for juvenile fish and shellfish, wildlife viewing, and acting as a natural storm surge buffer (BwH, 2012).



Map 4. Maine Tidal Power Initiative's Site Resource Assessment Published Habitat Map of Significant Wildlife and Essential Habitats. The red circle indicates the location of the VoltturnUS floating wind turbine.

Across the Bagaduce River and due south of Castine on the Cape Rosier peninsula lies the Holbrook Island Sanctuary. The sanctuary encompasses 1,230 acres of forests, fields, marshes, ponds, mudflats, and high-value wetland habitat. The Sanctuary is managed by the State of Maine under the Bureau of Parks and Lands, encouraging visitors to hike the trails and enjoy the abundant mammals and birds that frequent the park. A "Checklist of the

Birds” for Holbrook Island Sanctuary is available to help birders identify the timing and abundance of the avian species known to utilize this habitat (Holbrook Island Sanctuary, 2001). Out of the 223 birds listed in this checklist, 26 were observed in this survey; 10 of the observed species are also listed as “known to breed in the sanctuary.”

Although both the Bagaduce River watershed and the Holbrook Island Sanctuary are not directly in the area of the Castine Harbor Dice Head Test Turbine Site, the wildlife that use these habitats may, at some point, find contact with the turbine’s location. Due to the siting of the VoltturnUS 1/8<sup>th</sup> commercial scale floating platform near the mouth of the Bagaduce River, these hundreds of species known to use the Sanctuary and Bagaduce River’s habitats may follow the river on their way to Penobscot Bay and the pass by the test turbine’s location. For this reason, it is essential to keep in mind the ecological habitats within the vicinity of the Castine Harbor Dice Head Test Site and the avian species that are known to use its resources.

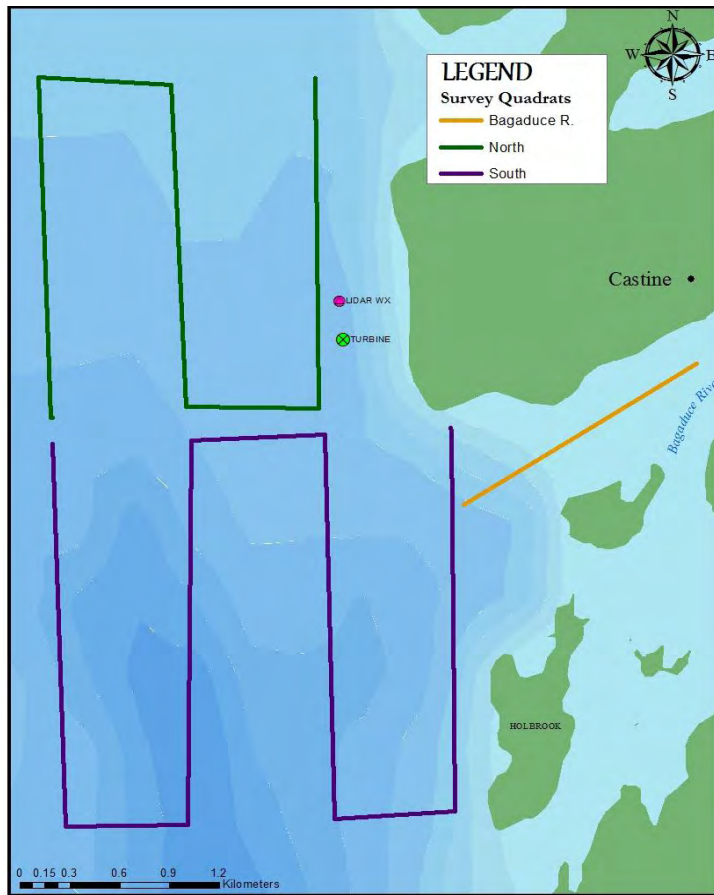
### III. METHODS

Visual boat-based observations were conducted at the Castine Harbor Dice Head Test Site from January to May of 2014. The survey vessels and captains were provided by Maine Maritime Academy, also located in Castine, Maine. Exact location of the comprehensive survey area was chosen to best cover the wildlife use of the Bagaduce River’s outlet and the area near Dice Head, at the western and southern edge of Castine’s peninsula, as seen previously in Map 1. No control or test area was designated, such as in the protocol used for the Monhegan Offshore Wind Turbine test site (Kennedy & Holberton, 2012); however two quadrats were surveyed using a similar experimental design.

The “north” quadrat covers the region to the west of the Castine peninsula, which is near Dice’s Head, and the “south” quadrat is adjacent to and south of the “north” quadrat, but also covering more of the river’s outlet and due west of Nautilus Island and the northern part of Holbrook Island (Map 5). A third single transect strip includes a single one-mile strip up from the river’s mouth. This was due to abundant bird activity and their use of the Bagaduce River’s “Significant Wildlife Habitat,” as noted under Focus Areas of Statewide Ecological Significance (BwH, 2012). The exact location of the 1/8<sup>th</sup> scale VoltturnUS test turbine on a floating platform is found within an existing cable way (as seen in Map 2) that lies within the area covered by the north quadrat’s coverage zone, between the 3<sup>rd</sup> strip of the transect and the Dice Head landmass.

To prevent confusion, the distinction of “Castine Test Site” refers to the entire surveyed area, and the smaller individual quadrats that lie within this larger area will be hereafter called the “north” or “N,” “south” or “S,” and “Bagaduce River” or “BR” sites, or

quadrats. The complete Castine Test Site covers roughly six square miles (15.64 km<sup>2</sup>) with the boat traveling a linear track totaling 13.4mi (21.5km) that includes both quadrats and



the river portion. All surveys were assessed equally while using the corresponding total survey areas of the south, north, and Bagaduce River quadrats for the analysis of the species composition, location, and behaviors observed within the Castine Test Site.

Map 5. Location of the survey quadrats used in the Castine Harbor Dice Head Test Site with UMaine’s VoltturnUS 1/8<sup>th</sup> scale floating turbine and Lidar Weather Station.

The north quadrat measures 1.3mi by one mile (3.4km<sup>2</sup>), the south quadrat measures 1.6mi x 1.5mi (6.2km<sup>2</sup>), and the Bagaduce River strip measures one mile long (1.6km). Surveys were performed with the vessel running at an average speed of 8.9 knots (16.4 k/h) in a N-S direction, or from the mouth of the Bagaduce River and heading upstream. Each day’s survey began at the starting waypoint in the south quadrat’s north-east corner. All birds, mammals, and other wildlife were documented when observed out to a distance of 500 m on both sides of the boat. After arriving at the next waypoint, surveying would stop and the boat would turn 90° along an E-W line and motor to the next waypoint. Once positioned on the starting point of the second transect strip, the vessel would turn again 90° and surveying would resume, heading in the N-S direction. This pattern was repeated to create four survey strips within the south quadrat (always performed first), followed by a short gap of 0.2 miles and then performing three survey strips, as previously described, to finish the north quadrat. Immediately following the north quadrat, surveying stopped until the vessel reached the starting point for the Bagaduce River’s transect.

All surveys were conducted upon the Maine Maritime Academy’s research vessel *M/V Quickwater*, a 41ft utility vessel driven by Captain Erin Bostrom, with one exception of a single survey on Jan 29 performed aboard the *M/V Captain Clark*, a 70ft vessel. Observations were conducted from the stern using binoculars and unaided vision. Height from which observations were made averaged 2.5 m above sea level, except on the *Captain Clark*, when observations were at 5m. All data were recorded into an RCA digital voice recorder, synchronized with time on a Garmin GPS unit that simultaneously logged the boat’s tracks and waypoints at the beginning and end of each transect line.

Codes used to document species behaviors and other observation and weather conditions followed Gould & Forsell (1989) and Tasker et al. (1984). Examples of common bird behaviors include but are not limited the behaviors provided in Table 1. See Appendix 1 for a complete list of behaviors. Other information includes flight height, estimated using the eye, and recorded in single meters when under a height of five meters or otherwise compartmentalized into five-meter "bins" (10, 15, 20, 25, etc.) up to 50 m. Observations were documented as “> 50 m” for all those above 50 m. The number of birds, species, gender and age (if known), and flight direction (see details below) were recorded. The data were transcribed into Excel and mapped with ArcMap 10.2 software.

Table 1. Example of most common codes used to document behaviors observed during transects (Gould & Forsell, 1989).

Bird Behavior
1 = Sitting on water
20 = Flying in direct and consistent heading
32 = Flying, following ship
35 = Flying, milling or circling (foraging)
48 = Flying, meandering
61 = Feeding at or near surface while flying (dipping or pattering)
65 = Feeding at or near surface, not diving or flying (surface scavenging)
71= Feeding below surface (pursuit diving)

Some of the most common behaviors documented have lengthy definitions; therefore a shortened descriptive behavior term is used in the following sections. These include the following codes: **#20**, described as “flying in a direct and consistent heading” but hereafter shortened to “direct flight”; **#35**, described as “flying, milling or circling” which typically involves flight associated with foraging behavior and is erratic in height and location, hereafter called “milling”; **#48**, described as “flying, meandering” which involves indirect flight that changes direction but not necessarily height, hereafter called “meandering”; **#61**, described as “feeding at or near the surface while flying (dipping or pattering)” which typically describes scavenging or the act of picking food from the water’s surface, hereafter called “pattering”; and **#65**, described as “feeding at or near surface, not diving or flying (surface scavenging)” which differs from dipping in that the bird is sitting in the water while foraging, hereafter called “scavenging.”



Four-letter species “alpha” codes may be used in the following tables to simplify table content (see Table 3 for species codes and common names and Appendix 2 also provides scientific names). Flight directions, given in cardinal direction such as NE, SW, WNW, represent the direction in which the bird was flying at the time of observation.

## IV. RESULTS

Fourteen survey days were conducted from January through May 2014. The total area covered on each survey day, which includes the 500m incorporated to each side of the transect strip, measured 8.24km<sup>2</sup> in the south quadrat, 5.8km<sup>2</sup> in the north quadrat, and 1.6km<sup>2</sup> in the Bagaduce River’s transect, for a grand total of 15.64km<sup>2</sup>.

Table 2 provides the breakdown of the surveys by time of day, sea, and weather conditions during this period of time. Eleven of the 14 days surveyed found the turbine blades spinning, which are noted also in Table 2, and oftentimes the turbine was spinning at a much reduced speed or experienced varying speeds throughout the duration of the survey period. This state of motion is noted only for the period of time in which the survey was conducted.

Table 2. Survey date, period, and weather conditions.

2014 DATES	DAY PERIOD		SEA CONDITION				Turbine Spinning?
	AM	PM	Sea Height (ft)	Wind Dir	Wind (kt)	Sky	
15-Jan		X	RIPPLE TO 0.5	S	3	Partly Cloudy	Y
29-Jan	X		FLAT	W	1	Overcast	N
6-Feb		X	0.5	WNW	5	Sunny	Y
25-Feb		X	1 TO 2	W	12 TO 15	Overcast	Y
3-Mar		X	3 TO 3.5	NNW	10 TO 15	Partly Cloudy	Y
19-Mar	X		RIPPLE	NW	3	Sunny	N
6-Apr	X		1.5 TO 2	NW	12	Sunny	Y
9-Apr		X	0.5	W	5	Sunny	Y
18-Apr	X		RIPPLE TO 0.5	E	5	Sunny	Y
29-Apr		X	1	E	6 TO 10	Partly Cloudy	Y
8-May		X	RIPPLE TO 1	SW	10	Sunny	Y
15-May	X		RIPPLE	SSW	8 TO 10	Foggy/Some Showers	N
22-May	X		RIPPLE TO 0.5	SW	5	Mostly Sunny	Y
28-May	X		1 TO 1.5	NNE	5	Overcast	Y

Table 3. All observed species with code, densities, and quadrat during January through May 2014.

Common name	Number	Overall /km <sup>2</sup>	SPP	NORTH	North/ km <sup>2</sup>	Most frequent	SOUTH	South/ km <sup>2</sup>	Most frequent	BR	BR/ km <sup>2</sup>	Most frequent
common loon	85	5.43	COLO	26	4.48	sitting	28	3.40	sitting	31	19.38	sitting
red-throated loon	9	0.58	RTLO	1	0.17	sitting	7	0.85	direct flight	1	0.63	sitting
mallard	20	1.28	MALL				5	0.61	sitting	15	9.38	milling
American black duck	8	0.51	ABDU							8	5.00	sitting
bufflehead	5	0.32	BUFF	4	0.69	sitting				1	0.63	sitting
long-tailed duck	37	2.37	LTDU	26	4.48	sitting/ direct flight	9	1.09	direct flight	2	1.25	sitting
common merganser	9	0.58	COME	3	0.52	underwater foraging	1	0.12	meandering	5	3.13	sitting/ direct flight
red-breasted merganser	8	0.51	RBME	4	0.69	sitting	2	0.24	sitting	2	1.25	direct flight/ meandering
Canada goose	42	2.69	CANG	37	6.38	direct flight	5	0.61	direct flight			
common eider	101	6.46	COEI	37	6.38	direct flight	43	5.22	direct flight	21	13.13	sitting
surf scoter	27	1.73	SUSC				27	3.28	sitting			
white-winged scoter	40	2.56	WWSC	34	5.86	sitting	6	0.73	meandering			
unidentified duck	42	2.69	UNDU	19	3.28	direct flight	12	1.46	direct flight	11	6.88	sitting
horned grebe	9	0.58	HOGR	2	0.34	sitting	5	0.61	sitting	2	1.25	direct flight/ underwater foraging
red-necked grebe	31	1.98	RNGR	8	1.38	sitting	18	2.18	sitting	5	3.13	sitting
herring gull	97	6.20	HERG	35	6.03	direct flight	37	4.49	sitting	25	15.63	meandering
laughing gull	3	0.19	LAGU	1	0.17	sitting	2	0.24	sitting/direct flight			
ring-billed gull	8	0.51	RBGU	3	0.52	meandering	5	0.61	direct flight			
black guillemot	85	5.43	BLGU	6	1.03	sitting/direct/ underwater	26	3.16	sitting	53	33.13	sitting
razorbill	22	1.41	RAZO	7	1.21	sitting	12	1.46	sitting	3	1.88	sitting
unidentified alcid	17	1.09	UNAL	8	1.38	sitting	9	1.09	direct flight			
double-crested cormorant	9	0.58	DCCO				5	0.61	sitting/direct flight	4	2.50	direct flight/ underwater foraging
American crow	9	0.58	AMCR	3	0.52	direct flight	5	0.61	direct flight	1	0.63	meandering
common raven	1	0.06	CORA				1	0.12	direct flight			
tree swallow	3	0.19	TRSW				3	0.36	direct flight			
bald eagle	1	0.06	BAEA				1	0.12	milling			
osprey	3	0.19	OSPR				2	0.24	direct flight/ meandering	1	0.63	direct
peregrine falcon	2	0.13	PEFA							2	1.25	sitting on rock nest
unidentified hawk	1	0.06	UNHA							1	0.63	direct
<b>Bird Total/km<sup>2</sup></b>	<b>734</b>	<b>3.35</b>		<b>264</b>	<b>3.25</b>		<b>276</b>	<b>2.39</b>		<b>194</b>	<b>8.66</b>	
harbor seal	18	1.15	HSEAL	4	0.69		10	1.21		4	2.50	
gray seal	1	0.06	GSEAL				1	0.12				
harbor porpoise	6	0.38	HAPO	2	0.34		4	0.49				
<b>Marine Mammal Total/km<sup>2</sup></b>	<b>25</b>	<b>1.60</b>		<b>6</b>	<b>0.07</b>		<b>15</b>	<b>0.13</b>		<b>4</b>	<b>0.18</b>	

Table 3 provides all species densities and in which quadrat, with the four-letter species code and common names for reference and also providing most frequent behavior of that species. For a more detailed table, Appendix 2 provides abundances and dates on which each species were recorded, including scientific names. Among the 26 bird species identified, which included 734 individual birds counted, only two definite State-Listed (MESA) species were observed and included a total of 22 razorbills (*Alca torda*; RAZO), listed as State Threatened and two peregrine falcons (*Falco peregrines*; PEFA) that are listed as State Endangered. However, additional birds were observed that were unable to be specifically identified to the species, but may have included other Federal (FT or FT\*) or State Threatened (StTh or StTh\*), Federal (FE) or State Endangered (StE), or other federal and state-designated conservation status species (BCC or SSC), as seen in Table 4. These will be discussed later in Part V Section D: *Endangered, Threatened, and Birds of Conservation Status*, below. Species that are, or potentially are, FE, FT, StE, or StTh will be marked by red text in the following tables. Also, to simplify terminology, these species will be hereafter lumped into “Species of Conservation Concern,” or SCC, and shall include the identified species as well as the potential SCC species.

One gray seal (*Halichoerus grypus*), 18 harbor seals (*Phoca vitulina*), and six harbor porpoise (*Phocoena phocoena*) were also noted during these surveys, none of which are species of concern.

Table 4. Species of special conservation designation, including potential species.

STATUS	SPECIES
BCC	red-throated loon
BCC	horned grebe
StTh*, SSC*	unidentified duck
SSC	laughing gull
StTh	razorbill
StTh*, SSC*	unidentified alcid
SSC	tree swallow
BCC, SSC	bald eagle
StE, BCC	peregrine falcon
SSC*	unidentified hawk

\* indicates potential SCC

The following sections will begin with Part V- Section A, presenting a survey by survey discussion, with tables and maps to outline species, numbers, and locations. Sections B through E will discuss bird behaviors, species of concern, and all other observations. Again, Appendix 2 provides a more detailed table of this data gathered per survey day. Throughout this report, four-letter species “alpha” codes are also used to simplify text and table content.

To further discuss the bird observations during these surveys, bird species will be generally grouped by a taxonomical classification at the Order level. Seven orders within

the Class Aves were observed utilizing this region within the Gulf of Maine during the course of our study. The maps and figures used in this report have been colored using a consistent scheme that groups each of these five Groups by color. Group 1 (eider, scoters, ducks, grebes, and loons) is represented by shades of green (hereafter called “Group 1A”), Group 2 (gulls and alcids) have yellows (“Group 2C”), Group 3 (cormorants) is red (“Group 3S”), Group 4 (crows, ravens, and songbirds) is blue (“Group 4P”), and Group 5 (osprey, eagles, and hawks) is brown (“Group 5A”). This color scheme will continue to be used when discussing bird behaviors, foraging species, and birds of conservation concern, as seen below. It does not include marine mammals or other species.

The five Species-Groups are as follows:

<b>-Order Anseriformes</b>	(eider, scoters, and ducks)	<b>GROUP 1</b>
<b>-Order Gaviiformes</b>	(loons)	
<b>-Order Podicipediformes</b>	(grebes)	
<b>-Order Charadriiformes</b>	(large and small gulls, alcids)	<b>GROUP 2</b>
<b>-Order Suliformes</b>	(cormorant)	<b>GROUP 3</b>
<b>-Order Passeriformes</b>	(corvids and songbirds)	<b>GROUP 4</b>
<b>-Order Accipiteriformes</b>	(osprey, eagles, hawks)	<b>GROUP 5</b>

## A. Surveys by Day

### JANUARY 15, 2014

### AFTERNOON SURVEY (14:16 pm)

Table 5. Numbers of species observed Jan 15.

Species	N	S	BR	Total
COLO	2	3	3	8
RTLO		2	1	3
ABDU			4	4
BUFF	1		1	2
COME	3	1	1	5
HOGR	2		1	3
RNGR	1		2	3
HERG	4		7	11
LAGU		1		1
RBGU	1			1
BLGU			8	8
RAZO	4			4
UNAL	8			8
AMCR		2		2
<b>Total</b>	<b>26</b>	<b>9</b>	<b>28</b>	<b>63</b>

Table 6. Bird species, behavior code, and flight height on Jan 15.

Behavior	1	10	20	35	48	71	Total			
Height (m)	0	0	1	10	15	10	1	15	0	Total
COLO	7								1	8
RTLO	2		1							3
ABDU	4									4
BUFF	1		1							2
COME						2			3	5
HOGR	2		1							3
RNGR	3									3
HERG	3	1		1	2	1			3	11
LAGU					1					1
RBGU				1						1
BLGU	8									8
RAZO	4									4
UNAL	8									8
AMCR					2					2
<b>Total</b>	<b>42</b>	<b>1</b>	<b>3</b>	<b>2</b>	<b>5</b>	<b>1</b>	<b>2</b>	<b>3</b>	<b>4</b>	<b>63</b>

On January 15<sup>th</sup>, conditions were rated as “Maximum” with seas averaging between a ripple to one-half foot (0.15 m), with winds from the south at three knots and partly cloudy sky. The VoltturnUS turbine was spinning at the time of the survey. Map 6 shows the general survey tracklines with the location and number of animals recorded. Of the 14 total bird species observed on this date, 44% were found in the BR quadrat and included nine species, followed by 41% found in the north, and only 14% in the south. The top four species on this day were HERG (17%), followed by common loon (*Gavia immer*; COLO) at 13%, black guillemot (*Cephus grille*; BLGU) at 13%, and unidentified alcids (UNAL) also with 13% (Table 5). No marine mammals were observed on this date.

Table 6 shows all behaviors by all bird species observed. Sixty-seven percent of all birds were observed sitting in the water followed by 16% of birds flying direct. Of all birds, eight percent demonstrated a foraging behavior.

# JANUARY 29, 2013

# MORNING SURVEY (9:33 am)

Table 7. Numbers of species observed on Jan 29.

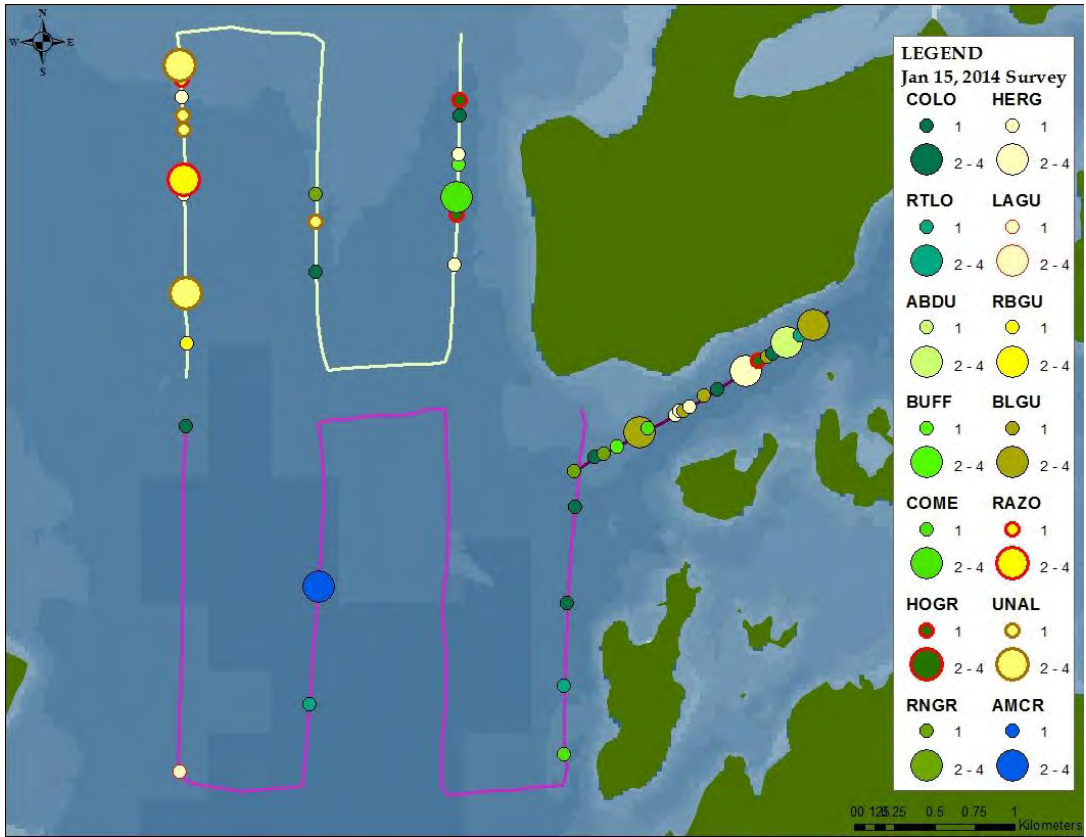
Species	N	S	BR	Total
RTLO		2		2
MALL			13	13
ABDU			4	4
LTDU	13			13
RBME	4	2	1	7
UNDU	4		10	14
RNGR	5	10		15
HERG	5	3	5	13
LAGU	1			1
BLGU		3	12	15
RAZO	3	10	3	16
UNAL		5		5
AMCR		1	1	2
HSEAL		1		1
<b>Total</b>	<b>35</b>	<b>37</b>	<b>49</b>	<b>121</b>

Table 8. Bird species, behavior code, and flight height on Jan 29.

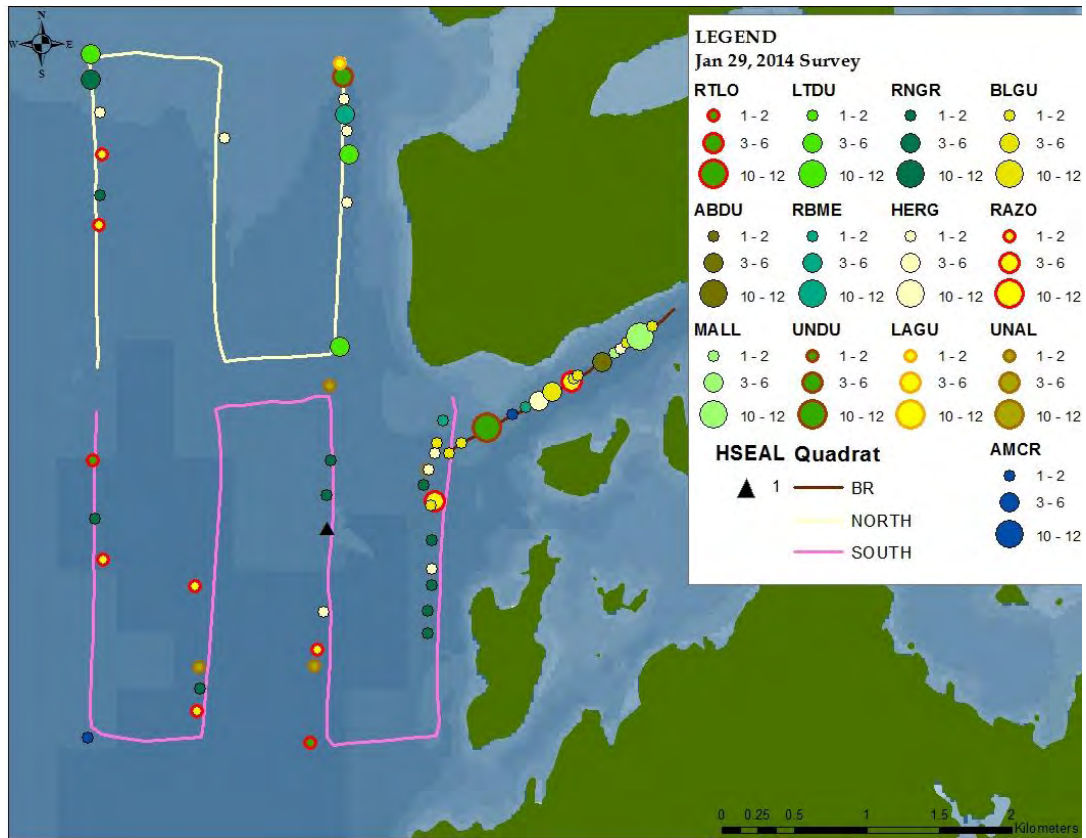
Behavior	1	20					35		48				71	Total
Height (m)	0	1	5	10	15	20	25	1	5	15	20	0		
RTLO		1											2	
MALL	1					12							13	
ABDU	4												4	
LTDU	4	3										6	13	
RBME	6	1											7	
UNDU	10	4											14	
RNGR	10	4										1	15	
HERG	1		1		2		1	1	2	4	1		13	
LAGU	1												1	
BLGU	10	2											15	
RAZO	12												16	
UNAL	2	1											5	
AMCR					1						1		2	
HSEAL	1												1	
<b>Total</b>	<b>62</b>	<b>16</b>	<b>1</b>	<b>1</b>	<b>2</b>	<b>12</b>	<b>1</b>	<b>1</b>	<b>3</b>	<b>5</b>	<b>1</b>	<b>16</b>	<b>121</b>	

On January 29<sup>th</sup>, conditions were rated as “Maximum” with flat seas, west winds at one knot, and an overcast sky. The VoltturnUS turbine was not spinning at the time of the survey. Map 7 shows the general survey tracklines with the location and number of animals recorded. Of the 13 total bird species observed on this date, 41% were found in the BR quadrat and included all 13 species, followed by 30% found in the south. The top three species on this day were razorbills (13%), followed by BLGU at 13%, and red-necked grebes (*Podiceps grisegena*; RNGR) also at 13% (Table 7). One harbor seal was observed on this date, found in the south quadrat.

Table 8 shows all behaviors by all bird species observed. Fifty-two percent of all birds were observed sitting in the water followed by 20% of birds flying direct and 13% foraging underwater. Of all birds, 24% demonstrated a foraging behavior.



Map 6. Observations of wildlife during Jan 15 survey.



Map 7. Observations of wildlife during Jan 29 survey.

## FEBRUARY 6, 2014

Table 9. Numbers of species observed Feb 6.

Species	N	S	BR	Total
COLO	2	1	3	6
RTLO		1		1
BUFF	3			3
RBME			1	1
UNDU		3	1	4
RNGR		1	1	2
HERG		24	1	25
LAGU		1		1
RBGU		1		1
BLGU		2	3	5
HAPO	2			2
<b>Total</b>	<b>7</b>	<b>34</b>	<b>10</b>	<b>51</b>

## AFTERNOON SURVEY (14:14 pm)

Table 10. Bird species, behavior code, and flight height on Feb 6.

Behavior	1	20			48		Total
Height (m)	0	1	5	15	1	5	
COLO	6						6
RTLO		1					1
BUFF	3						3
RBME						1	1
UNDU		2			2		4
RNGR	1	1					2
HERG	23		2				25
LAGU	1						1
RBGU				1			1
BLGU	4	1					5
HAPO	2						2
<b>Total</b>	<b>40</b>	<b>5</b>	<b>2</b>	<b>1</b>	<b>2</b>	<b>1</b>	<b>51</b>

On February 6<sup>th</sup>, conditions were rated as “Maximum” with seas at a half foot (0.15m), WNW winds at five knots, and sunny skies. The VoltturnUS turbine was spinning at the time of the survey. Map 8 shows the general survey tracklines with the location and number of animals recorded. Of the 10 total bird species observed on this date, 69% were found in the south quadrat and included eight species, followed by 20% found in the BR. The top three species on this day were herring gulls (*Larus argentatus*; HERG; 51%), followed by COLO at 12%, and BLGU at 10% (Table 9). Two harbor porpoise were observed on this date, found in the north quadrat.

Table 10 shows all behaviors by all bird species observed. Seventy-eight percent of all birds were observed sitting in the water followed by 16% of birds flying direct. No foraging behaviors were observed on this date.



## FEBRUARY 25, 2014

## AFTERNOON SURVEY (14:13 pm)

Table 11. Numbers of species observed Feb 25.

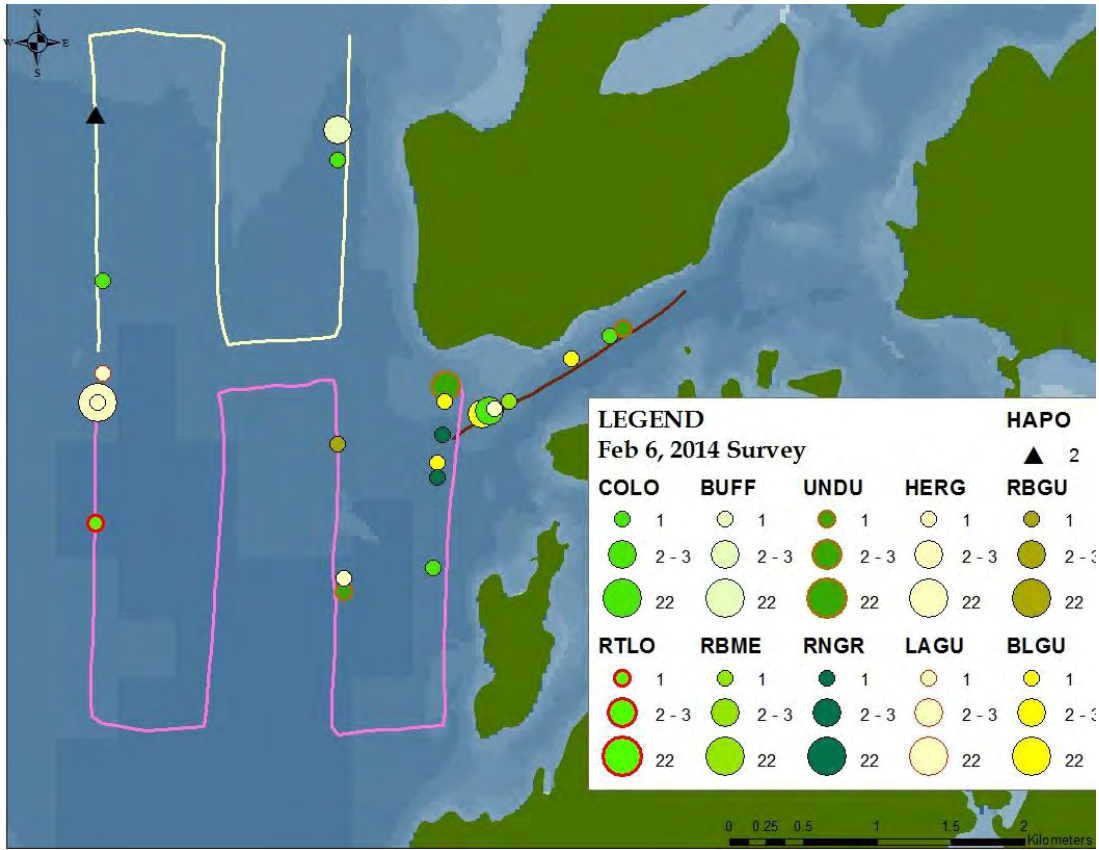
Species	N	S	BR	Total
COLO			1	1
RTLO	1			1
LTDU	7		2	9
UNDU	2	3		5
RNGR		1		1
HERG	1		3	4
BLGU		4	4	8
RAZO		2		2
UNAL		1		1
BAEA		1		1
<b>Total</b>	<b>11</b>	<b>12</b>	<b>10</b>	<b>33</b>

Table 12. Bird species, behavior code, and flight height on Feb 25.

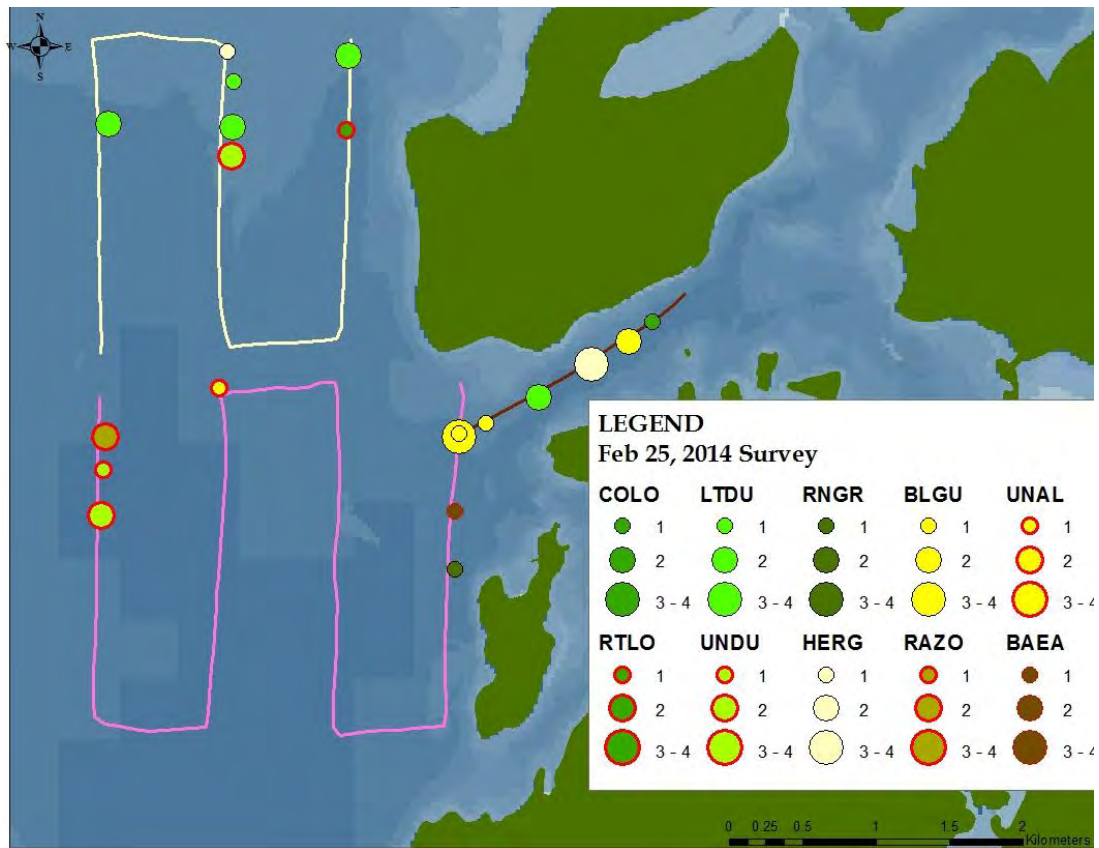
Behavior	1	20	35	48	Total	
Height (m)	0	1	3	15	5	Total
COLO	1					1
RTLO		1				1
LTDU	4	5				9
UNDU	3	2				5
RNGR		1				1
HERG			3		1	4
BLGU	7	1				8
RAZO	2					2
UNAL		1				1
BAEA				1		1
<b>Total</b>	<b>17</b>	<b>11</b>	<b>3</b>	<b>1</b>	<b>1</b>	<b>33</b>

On February 25<sup>th</sup>, conditions were rated as “Maximum” with seas averaging one to two feet (0.3 - 0.46 m), west winds at 12-15kts, and overcast skies. The VoltturnUS turbine was spinning at the time of the survey. Map 9 shows the general survey tracklines with the location and number of animals recorded. Of the 10 total bird species observed on this date, 36% were found in the south quadrat and included only six species, followed by 33% found in the north. The top three species on this day were long-tailed ducks (*Clangula hyemalis*; LTDU) at 27%, followed by BLGU at 24%, and unidentified ducks at 15% (Table 11). No marine mammals were observed on this date.

Table 12 shows all behaviors by all bird species observed. Fifty-two percent of all birds were observed sitting in the water followed by 33% of birds flying direct. Foraging behaviors were observed in 12% of all birds on this date.



Map 8. Observations of wildlife during Feb 6 survey.



Map 9 Observations of wildlife during Feb 25 survey.

# MARCH 3, 2014

# MORNING SURVEY (9:26 am)

Table 13. Numbers of species observed Mar 3.

Species	N	S	BR	Total
LTDU	2			2
COME			1	1
COEI			1	1
RNGR		1		1
HERG	1	2		3
RBGU	2	2		4
BLGU		1	3	4
CORA		1		1
HAPO		3		3
<b>Total</b>	<b>5</b>	<b>10</b>	<b>5</b>	<b>20</b>

Table 14. Bird species, behavior code, and flight height on Mar 3.

Behavior	1	20					32	48	Total
Height (m)	0	1	10	15	20	5	10		
LTDU		2						2	
COME	1							1	
COEI	1							1	
RNGR		1						1	
HERG			1		1	1		3	
RBGU		1	1				2	4	
BLGU	3	1						4	
CORA				1				1	
HAPO	3							3	
<b>Total</b>	<b>8</b>	<b>5</b>	<b>2</b>	<b>1</b>	<b>1</b>	<b>1</b>	<b>2</b>	<b>20</b>	

On March 3<sup>rd</sup>, conditions were rated as “Average” to “Good” due to three to 3.5ft seas (0.9 – 1.1 m), NNW winds at 10-15kts, and partly cloudy skies. The VoltturnUS turbine was spinning at the time of the survey. Map 10 shows the general survey tracklines with the location and number of animals recorded. Of the eight total bird species observed on this date, 41% were found in the south quadrat and included only five species, followed by 29% each found in the north and BR quadrats. The top three species on this day were ring-billed gulls (*L. delawarensis*; RBGU) at 24%, BLGU also at 24%, and HERG at 18% (Table 13). Three harbor porpoise were observed on this date, found in the south quadrat.

Table 14 shows all behaviors by all bird species observed. Fifty-three percent of all birds were observed flying direct followed by 29% of birds sitting in the water. No foraging behaviors were observed on this date.

# MARCH 19, 2014

# MORNING SURVEY (8:45 am)

Table 15. Numbers of species observed Mar 19.

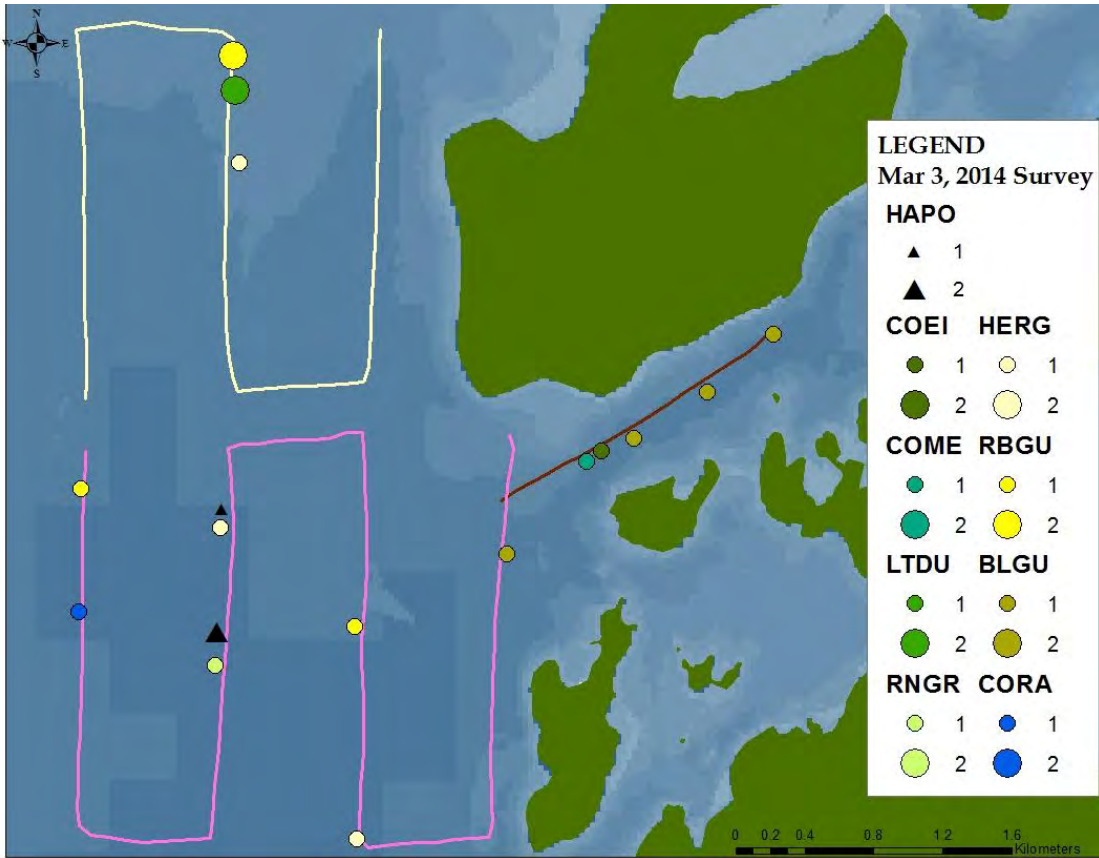
Species	N	S	BR	Total
COLO	2	3	2	7
MALL			2	2
LTDU	2			2
COEI			3	3
UNDU	1			1
HOGR		3		3
RNGR		2		2
HERG	2		1	3
BLGU	2	4	9	15
UNAL		2		2
AMCR	2			2
HSEAL		1	1	2
<b>Total</b>	<b>11</b>	<b>15</b>	<b>18</b>	<b>44</b>

Table 16. Bird species, behavior code, and flight height on Mar 19.

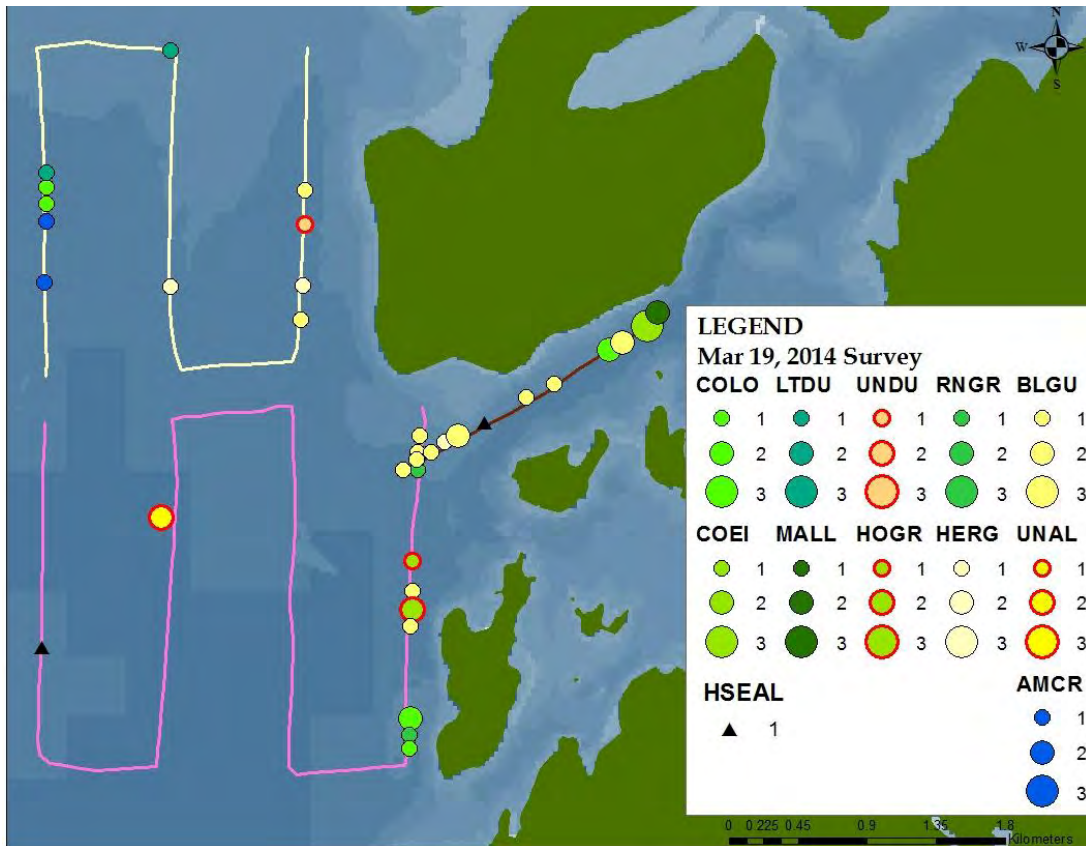
Behavior	1	20				Total
Height (m)	0	1	5	15	20	
COLO	7					7
MALL	2					2
LTDU	2					2
COEI	3					3
UNDU	1					1
HOGR	3					3
RNGR	2					2
HERG	1		1	1		3
BLGU	14	1				15
UNAL		2				2
AMCR				1	1	2
HSEAL	2					2
<b>Total</b>	<b>37</b>	<b>3</b>	<b>1</b>	<b>2</b>	<b>1</b>	<b>44</b>

On March 19<sup>th</sup>, conditions were rated as “Maximum” with seas at a ripple, NW winds at three knots, and sunny skies. The VoltturnUS turbine was not spinning at the time of the survey. Map 11 shows the general survey tracklines with the location and number of animals recorded. Of the 11 total bird species observed on this date, 40% were found in the BR quadrat and included only five species, followed by 33% found in the south quadrat. The top two species on this day were BLGU at 36% and COLO at 17% (Table 15). Two harbor seals were observed on this date, one each found in the south and BR quadrats.

Table 16 shows all behaviors by all bird species observed. Eighty-three percent of all birds were observed sitting in the water and the remainder of the birds flew direct. No foraging behaviors were observed on this date.



Map 10 Observations of wildlife during March 3 survey.



Map 11 Observations of wildlife during March 19 survey.

# APRIL 6, 2014

# AFTERNOON SURVEY (16:07 pm)

Table 17. Numbers of species observed April 6.

Species	N	S	BR	Total
COLO	1	3	3	7
CANG	37			37
COEI			6	6
UNDU	2			2
RNGR			2	2
HERG			1	1
BLGU			4	4
<b>Total</b>	<b>40</b>	<b>3</b>	<b>16</b>	<b>59</b>

Table 18. Bird species, behavior code, and flight height on Apr 6.

Behavior	1	20				Total
Height (m)	0	1	2	10	20	
COLO	5	1	1			7
CANG					37	37
COEI	6					6
UNDU	2					2
RNGR	2					2
HERG				1		1
BLGU	4					4
<b>Total</b>	<b>19</b>	<b>1</b>	<b>1</b>	<b>1</b>	<b>37</b>	<b>59</b>

On April 6<sup>th</sup>, conditions were rated as “Excellent” with seas averaging 1.5 – 2ft (0.46 – 0.6m), NW winds at 12 knots, and sunny skies. The VoltturnUS turbine was spinning at the time of the survey. Map 12 shows the general survey tracklines with the location and number of animals recorded. Of the seven total bird species observed on this date, 68% were found in the north quadrat but included only three species, followed by 27% found in the BR quadrat. The top three species on this day were Canada geese (*Branta canadensis*; CANG) at 63%, followed by COLO at 12%, and common eider (*Somateria mollissima*; COEI) at 10% (Table 17). No marine mammals were observed on this date.

Table 18 shows all behaviors by all bird species observed. Sixty-eight percent of all birds were observed flying direct and the remainder of the birds sat in the water. No foraging behaviors were observed on this date.

# APRIL 9, 2014

# MORNING SURVEY (8:03 am)

Table 19. Numbers of species observed April 9.

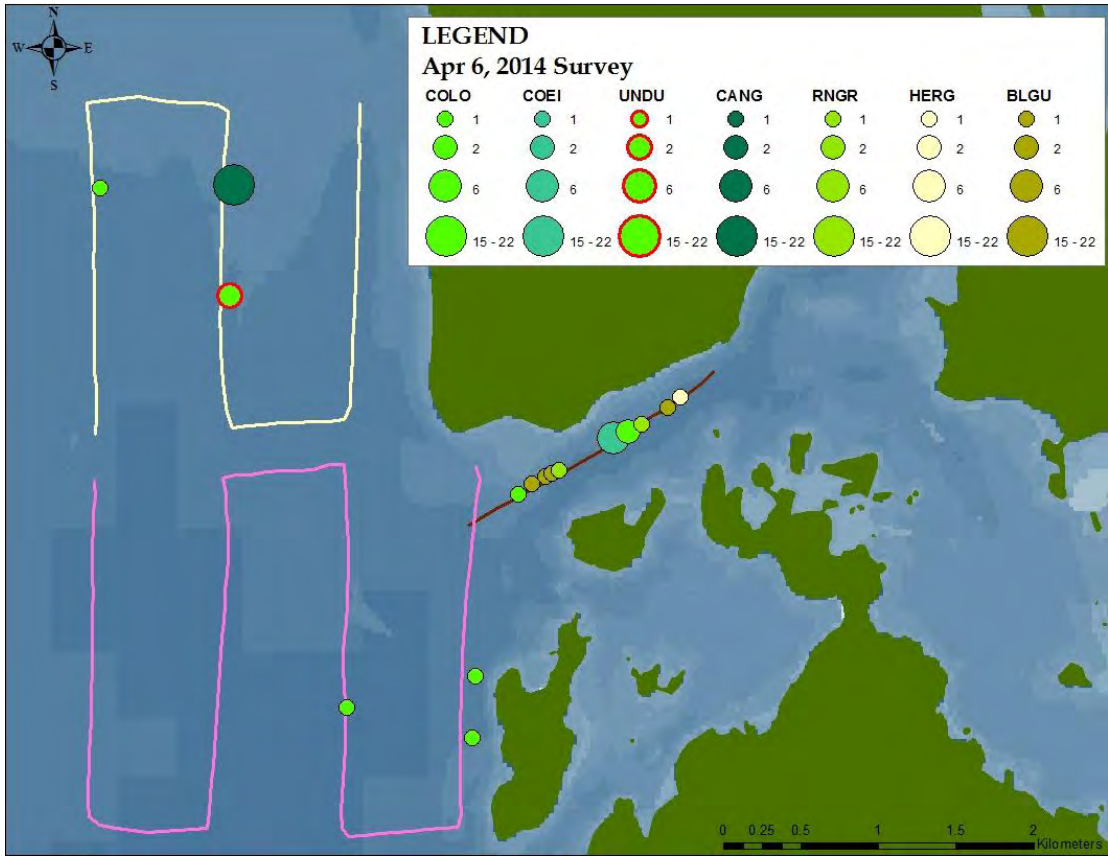
Species	N	S	BR	Total
COLO	2	3	1	6
MALL		5		5
LTDU	2	9		11
CANG		5		5
COEI	21	42	6	69
WWSC		1		1
UNDU	4	2		6
RNGR		2		2
HERG	2			2
RBGU		1		1
BLGU	1		4	5
UNAL		1		1
AMCR	1	2		3
HSEAL		1		1
<b>Total</b>	<b>32</b>	<b>75</b>	<b>11</b>	<b>118</b>

Table 20. Bird species, behavior code, and flight height on Apr 9.

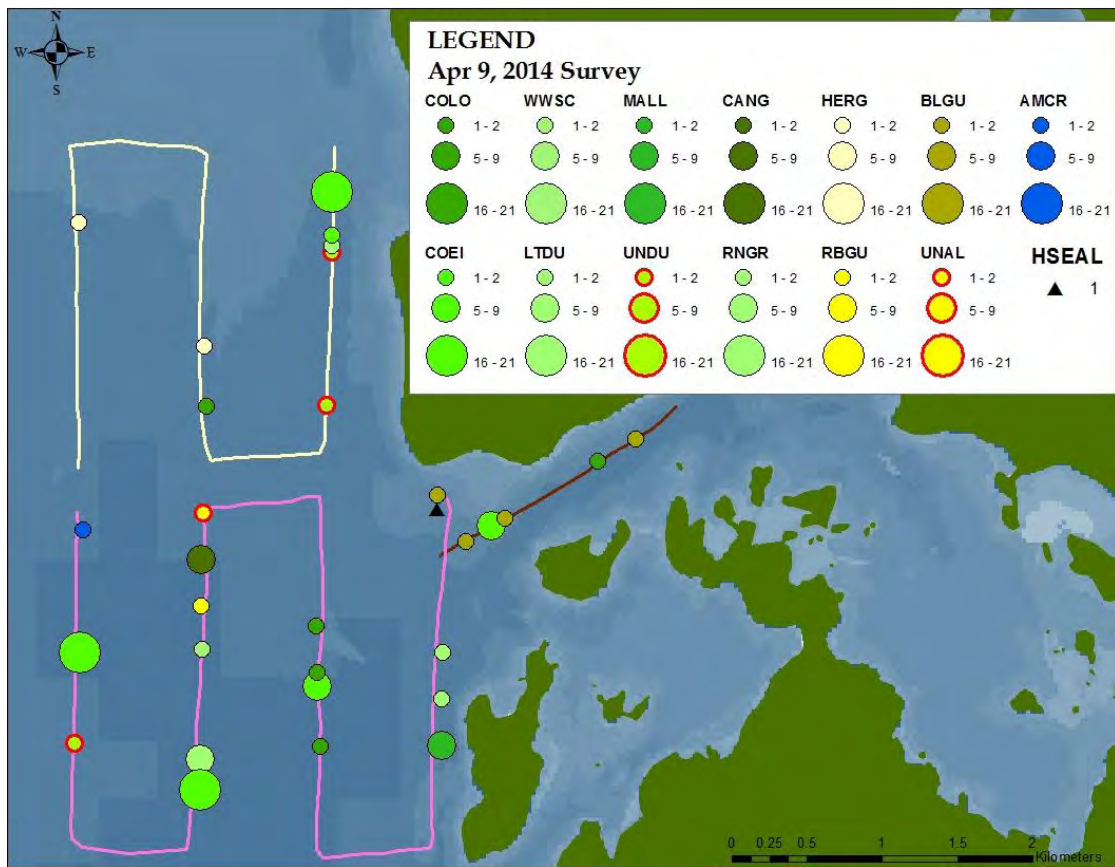
Behavior	1	20									Total
Height (m)	0	1	2	3	5	10	15	20	25		
COLO	2	2			2					6	
MALL	5									5	
LTDU	2	9								11	
CANG									5	5	
COEI	43	21	5							69	
WWSC		1								1	
UNDU	2	4								6	
RNGR	2									2	
HERG							1	1		2	
RBGU							1			1	
BLGU	4	1								5	
UNAL		1								1	
AMCR			2			1				3	
HSEAL	1									1	
<b>Total</b>	<b>61</b>	<b>39</b>	<b>5</b>	<b>2</b>	<b>2</b>	<b>1</b>	<b>2</b>	<b>1</b>	<b>5</b>	<b>118</b>	

On April 9<sup>th</sup>, conditions were rated as “Maximum” with seas averaging a half foot (0.15m), west winds at five knots, and sunny skies. The VoltturnUS turbine was spinning at the time of the survey. Map 13 shows the general survey tracklines with the location and number of animals recorded. Of the 13 total bird species observed on this date, 63% were found in the south quadrat and included 12 species, followed by 27% found in the north quadrat. The top two species on this day were COEI at 59%, followed by LTDU at 9% (Table 19). One harbor seal was observed on this date, located in the south quadrat.

Table 20 shows all behaviors by all bird species observed. Fifty-one percent of all birds were observed sitting in the water and the remainder of the birds flew direct. No foraging behaviors were observed on this date.



Map 12 Observations of wildlife during April 6 survey.



Map 13 Observations of wildlife during April 9 survey.



# APRIL 18, 2014

# MORNING SURVEY (8:06 am)

Table 21. Numbers of species observed April 18.

Species	N	S	BR	Total
COLO	4	3	2	9
RTLO		1		1
COEI	16			16
SUSC		3		3
UNDU	2	2		4
RNGR	1	1		2
HERG	1		2	3
BLGU	2	1	3	6
OSPR		1		1
HSEAL			1	1
HAPO		1		1
<b>Total</b>	<b>26</b>	<b>13</b>	<b>8</b>	<b>47</b>

Table 22. Bird species, behavior code, and flight height on Apr 18.

Behavior	1	10	20			35	48	71	Total	
Height (m)	0	1	1	3	5	15	25	10	0	
COLO	5		1	1	1	1				9
RTLO								1		1
COEI	16									16
SUSC				3						3
UNDU	2		2							4
RNGR	2									2
HERG	2						1			3
BLGU	3		1						2	6
OSPR								1		1
HSEAL			1							1
HAPO	1									1
<b>Total</b>	<b>31</b>	<b>1</b>	<b>4</b>	<b>4</b>	<b>1</b>	<b>1</b>	<b>1</b>	<b>1</b>	<b>3</b>	<b>47</b>

On April 18<sup>th</sup>, conditions were rated as “Maximum” with seas averaging a ripple to a half foot (0.05-0.15m), east winds at five knots, and sunny skies. The VoltturnUS turbine was spinning at the time of the survey. Map 14 shows the general survey tracklines with the location and number of animals recorded. Of the nine total bird species observed on this date, 58% were found in the north quadrat and included six species, followed by 27% found in the south quadrat. The top three species on this day were COEI at 36%, followed by COLO at 20%, and BLGU at 13% (Table 21). One harbor seal was observed on this date, located in the BR and one harbor porpoise was observed in the south quadrat.

Table 22 shows all behaviors by all bird species observed. Sixty-seven percent of all birds were observed sitting in the water followed by 22% flying direct. Foraging behaviors were observed in nine percent of all bird behaviors on this date.

# APRIL 29, 2014

# AFTERNOON SURVEY (13:18 pm)

Table 23. Numbers of species observed April 29.

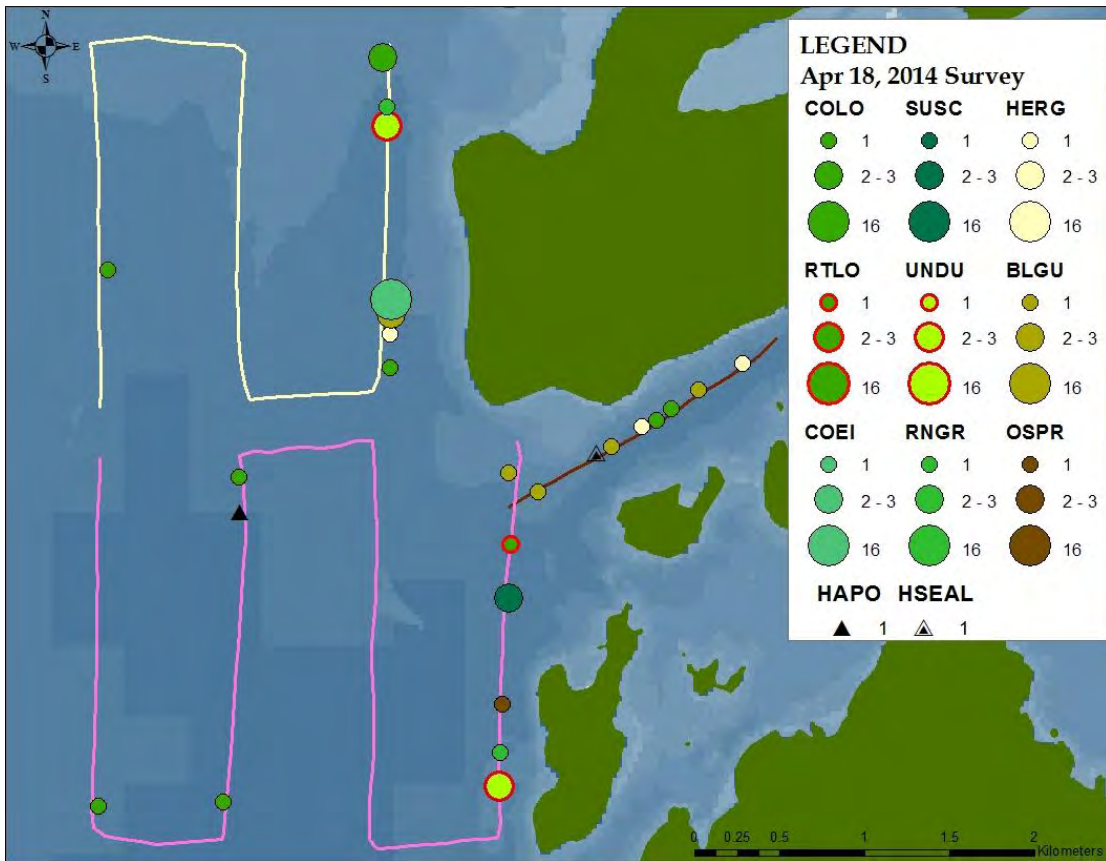
Species	N	S	BR	Total
COLO	4	1	5	10
COME			3	3
COEI			5	5
SUSC		5		5
UNDU	2			2
RNGR	1			1
HERG		2		2
BLGU	2	5	1	8
DCCO		1	1	2
TRSW		3		3
OSPR		1		1
PEFA			2	2
UNHA			1	1
HSEAL	1	2	1	4
<b>Total</b>	<b>10</b>	<b>20</b>	<b>19</b>	<b>49</b>

Table 24. Bird species, behavior code, and flight height on Apr 29.

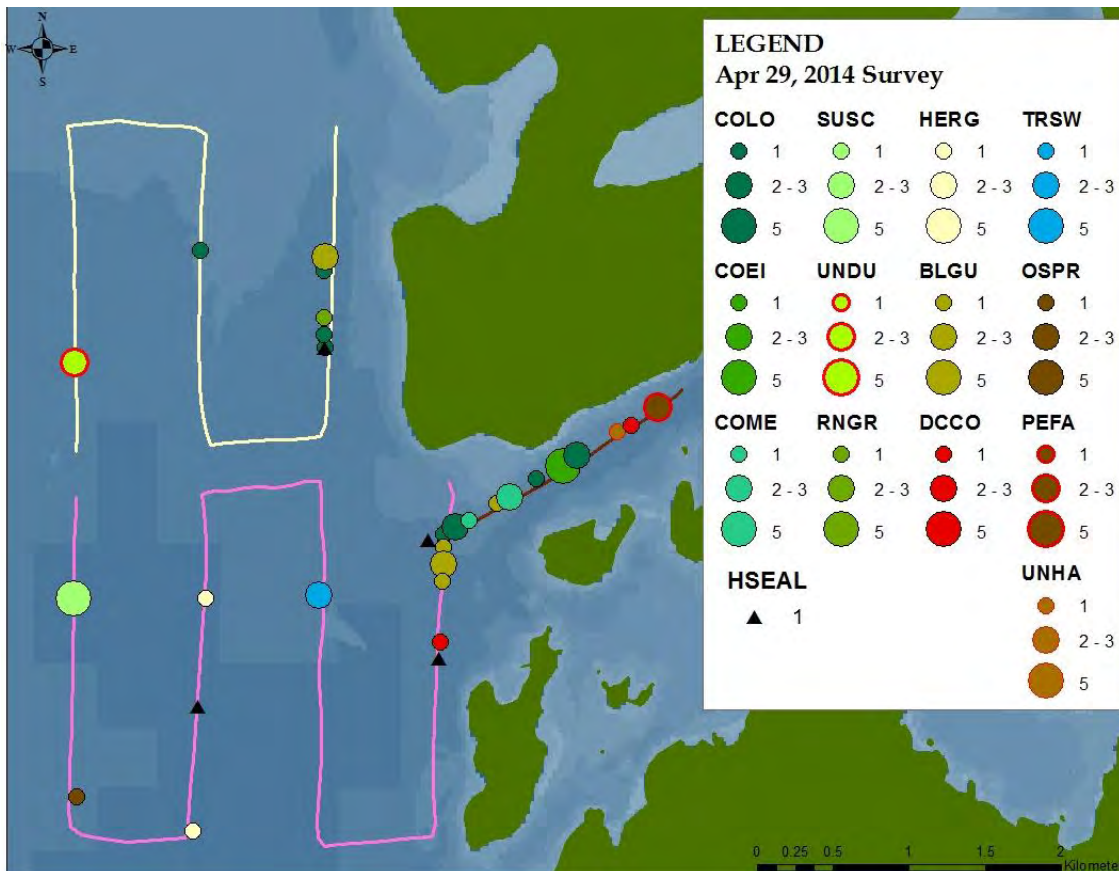
Behavior	1	10	20	71	Total		
Height (m)	0	0	1	10	45	1	
COLO		10					10
COME		1		2			3
COEI		5					5
SUSC		5					5
UNDU		2					2
RNGR		1					1
HERG				1	1		2
BLGU		2		6			8
DCCO				1		1	2
TRSW				3			3
OSPR				1			1
PEFA				2			2
UNHA						1	1
HSEAL		4					4
<b>Total</b>	<b>30</b>	<b>2</b>	<b>14</b>	<b>1</b>	<b>1</b>	<b>1</b>	<b>49</b>

On April 29<sup>th</sup>, conditions were rated as “Maximum” with seas averaging one foot (0.3m), east winds at six to 10 knots, and partly cloudy skies. The VoltturnUS turbine was spinning at the time of the survey. Map 15 shows the general survey tracklines with the location and number of animals recorded. Of the 13 total bird species observed on this date, 40% were found in each the south and BR quadrats, consisting of a variety of seven species in each. The top two species on this day were COLO at 22%, followed by BLGU at 18% (Table 23). Four harbor seals were observed on this date, dispersed throughout all three quadrats.

Table 24 shows all behaviors by all bird species observed. Fifty-eight percent of all birds were observed sitting in the water followed by 36% flying direct. Foraging behaviors were observed by one DCCO on this date.



Map 14 Observations of wildlife during April 18 survey.



Map 15 Observations of wildlife during April 29 survey.

# MAY 8, 2014

# AFTERNOON SURVEY (14:20 pm)

Table 25. Numbers of species observed May 8.

Species	N	S	BR	Total
COLO	4	4	3	11
UNDU		2		2
HOGR		2	1	3
HERG	1	1		2
RBGU		1		1
BLGU		2		2
DCCO		1		1
OSPR			1	1
HSEAL	1	3		4
<b>Total</b>	<b>6</b>	<b>16</b>	<b>5</b>	<b>27</b>

Table 26. Bird species, behavior code, and flight height on May 8.

Behavior	1	20	35	71	Total			
Height (m)	0	1	2	5	20	15	0	
COLO	8		1	1			1	11
UNDU			2					2
HOGR	2						1	3
HERG					1	1		2
RBGU				1				1
BLGU	2							2
DCCO	1							1
OSPR		1						1
HSEAL	4							4
<b>Total</b>	<b>17</b>	<b>1</b>	<b>3</b>	<b>2</b>	<b>1</b>	<b>1</b>	<b>2</b>	<b>27</b>

On May 8<sup>th</sup>, conditions were rated as “Maximum” with seas averaging a ripple to one foot (0.05-0.3m), SW winds at 10 knots, and sunny skies. The VolturnUS turbine was spinning at the time of the survey. Map 16 shows the general survey tracklines with the location and number of animals recorded. Of the eight total bird species observed on this date, 57% were found in the south quadrat, and included seven of the species. The most prevalent species on this day were COLO at 48% (Table 25). Four harbor seals were observed on this date, dispersed throughout all three quadrats.

Table 26 shows all behaviors by all bird species observed. Fifty-four percent of all birds were observed sitting in the water followed by 30% flying direct. Foraging behaviors were observed by nine percent of all birds on this date.

# MAY 15, 2014

# MORNING SURVEY (9:29 am)

Table 27. Numbers of species observed May 15.

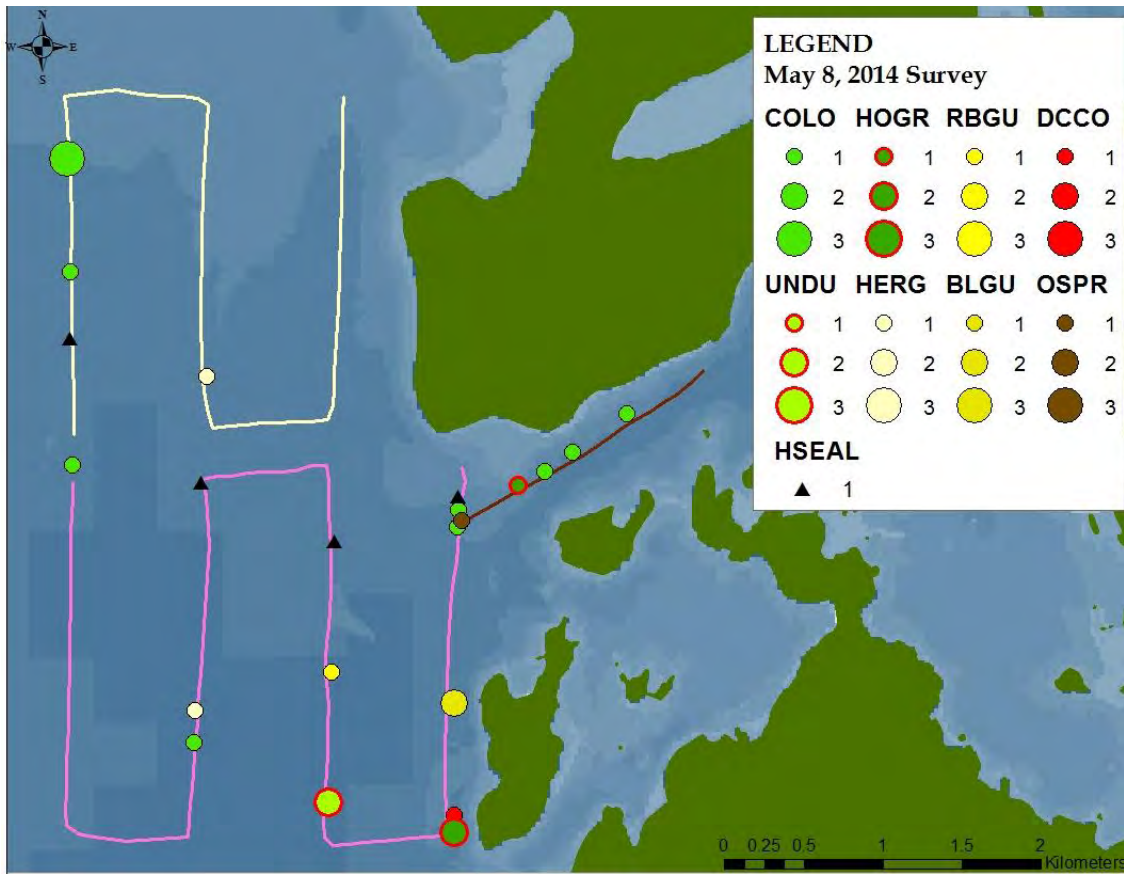
Species	N	S	BR	Total
COLO	2	1	4	7
RTLO		1		1
COEI		1		1
WWSC		4		4
HERG	11	1		12
BLGU		1	1	2
DCCO			1	1
HSEAL	1	1		2
GSEAL		1		1
<b>Total</b>	<b>14</b>	<b>11</b>	<b>6</b>	<b>31</b>

Table 28. Bird species, behavior code, and flight height on May 15.

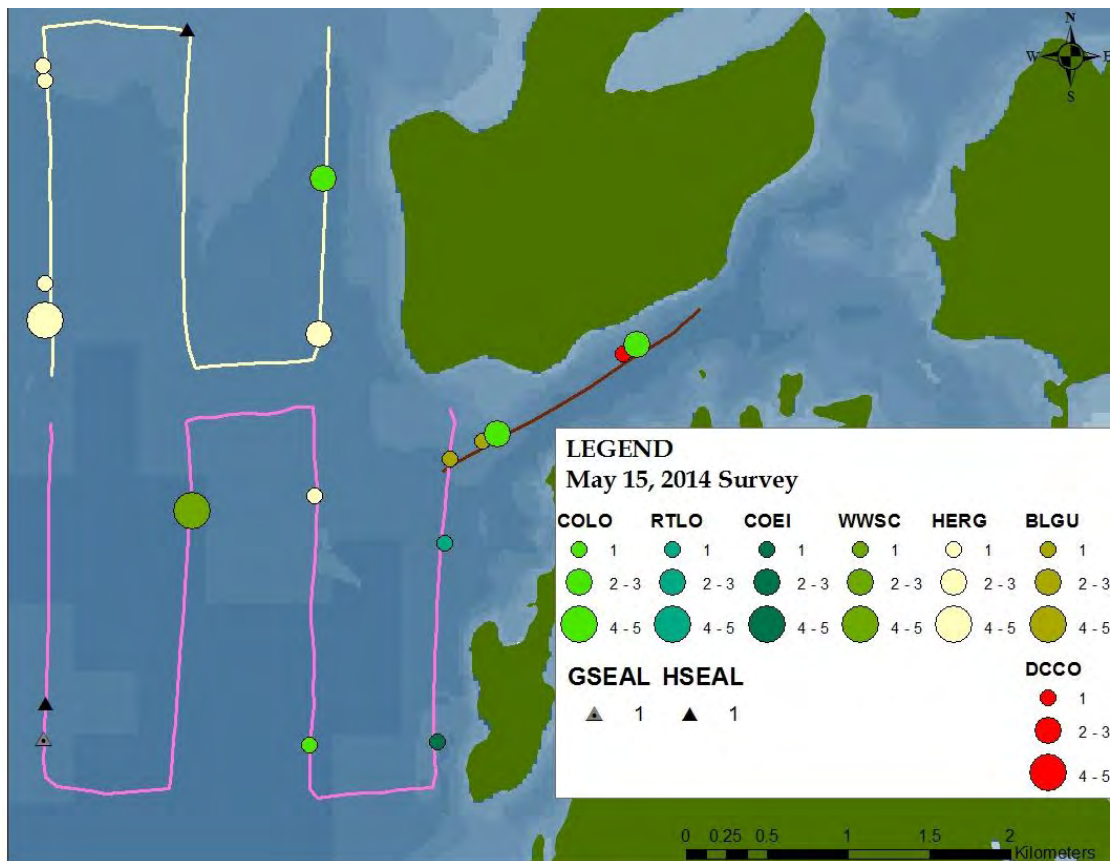
Behavior	1	20	48	Total
Height (m)	0	1	3	2
COLO	7			7
RTLO	1			1
COEI	1			1
WWSC			4	4
HERG		11	1	12
BLGU	2			2
DCCO		1		1
HSEAL	2			2
GSEAL	1			1
<b>Total</b>	<b>14</b>	<b>12</b>	<b>1</b>	<b>4</b>
				<b>31</b>

On May 15<sup>th</sup>, conditions were rated as “Good” to “Excellent” due to partial fog and light rain. Seas were only at a ripple and winds were SSW eight to 10 knots. The VoltturnUS turbine was not spinning at the time of the survey. Map 17 shows the general survey tracklines with the location and number of animals recorded. Of the seven total bird species observed on this date, 46% were found in the north quadrat, but included only two of the species. The top three species on this day were HERG at 43%, followed by COLO at 25%, and white-winged scoter (*Melanitta fusca*; WWSC) at 14% (Table 27). Two harbor seals in the north and south quadrats and one gray seal in the south quadrat were observed on this date.

Table 28 shows all behaviors by all bird species observed. Forty-six percent of all birds were observed flying direct followed by 39% sitting in the water. No foraging behaviors were observed on this date.



Map 16 Observations of wildlife during May 8 survey.



Map 17 Observations of wildlife during May 15 survey.

# MAY 22, 2014

# MORNING SURVEY (10:13 am)

Table 29. Numbers of species observed May 22.

Species	N	S	BR	Total
COLO	1	2	1	4
SUSC		19		19
WWSC	34	1		35
UNDU	2			2
HERG	1	2	4	7
DCCO		2	2	4
HSEAL	1	1	1	3
<b>Total</b>	<b>39</b>	<b>27</b>	<b>8</b>	<b>74</b>

Table 30. Bird species, behavior code, and flight height on May 15.

Behavior	1	10	20	71	Total			
Height (m)	0	0	1	10	15	20	0	
COLO	3					1		4
SUSC	19							19
WWSC	34		1					35
UNDU			2					2
HERG	6				1			7
DCCO			1	1			2	4
HSEAL	2	1						3
<b>Total</b>	<b>64</b>	<b>1</b>	<b>4</b>	<b>1</b>	<b>1</b>	<b>1</b>	<b>2</b>	<b>74</b>

On May 22<sup>nd</sup>, conditions were rated as “Maximum” with seas averaging a ripple to a half foot (0.05 - 0.15 m) with SW winds at five knots and mostly sunny skies. The VoltturnUS turbine was spinning at the time of the survey. Map 18 shows the general survey tracklines with the location and number of animals recorded. Of the six total bird species observed on this date, 54% were found in the north quadrat and consisting of only four species, followed by 37% in the south quadrat. The top two species on this day were WWSC at 49%, followed by surf scoter (*M. perspicillata*; SUSC) at 27% (Table 29). Three harbor seals were observed on this date, one found in each of the quadrats.

Table 30 shows all behaviors by all bird species observed. Eighty-seven percent of all birds were observed sitting in the water followed by 10% flying direct. Two DCCO were observed foraging underwater on this date.

# MAY 28, 2014

# MORNING SURVEY (10:18 am)

Table 31. Numbers of species observed May 28.

Species	N	S	BR	Total
COLO	2	4	3	9
HERG	6	2	1	9
BLGU		2	1	3
DCCO		1		1
<b>Total</b>	<b>8</b>	<b>9</b>	<b>5</b>	<b>22</b>

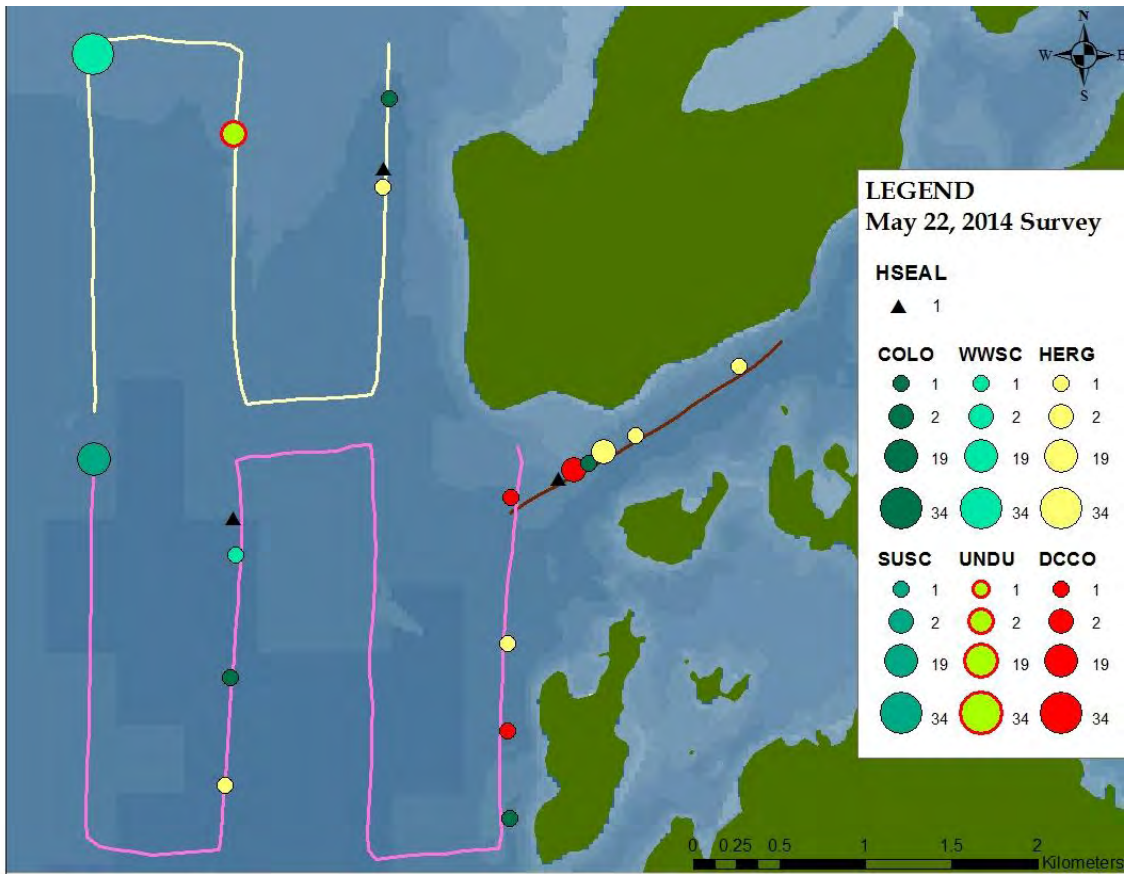
Table 32. Bird species, behavior code, and flight height on May 28.

Behavior	1	20	32		35			48		Total
Height (m)	0	5	10	5	10	10	25	30	35	1
COLO	8	1								9
HERG			1	1	1	1	2	1	1	1
BLGU	3									3
DCCO	1									1
<b>Total</b>	<b>12</b>	<b>1</b>	<b>1</b>	<b>1</b>	<b>1</b>	<b>1</b>	<b>2</b>	<b>1</b>	<b>1</b>	<b>1</b>

On May 28<sup>th</sup>, conditions were rated as “Maximum” with seas averaging one to 1.5ft (0.3 - 0.46 m) with south winds at five knots and overcast skies. The VoltturnUS turbine was spinning at the time of the survey. Map 19 shows the general survey tracklines with the location and number of animals recorded. Of the four total bird species observed on this date, 41% were found in the south quadrat and consisting of all four species, followed by 36% in the north quadrat. The top two species on this day were COLO and HERG, both found at 41% (Table 31). No marine mammals were observed on this date.

Table 32 shows all behaviors by all bird species observed. Fifty-five percent of all birds were observed sitting on the water followed by 23% milling.





Map 18 Observations of wildlife during May 22 survey.



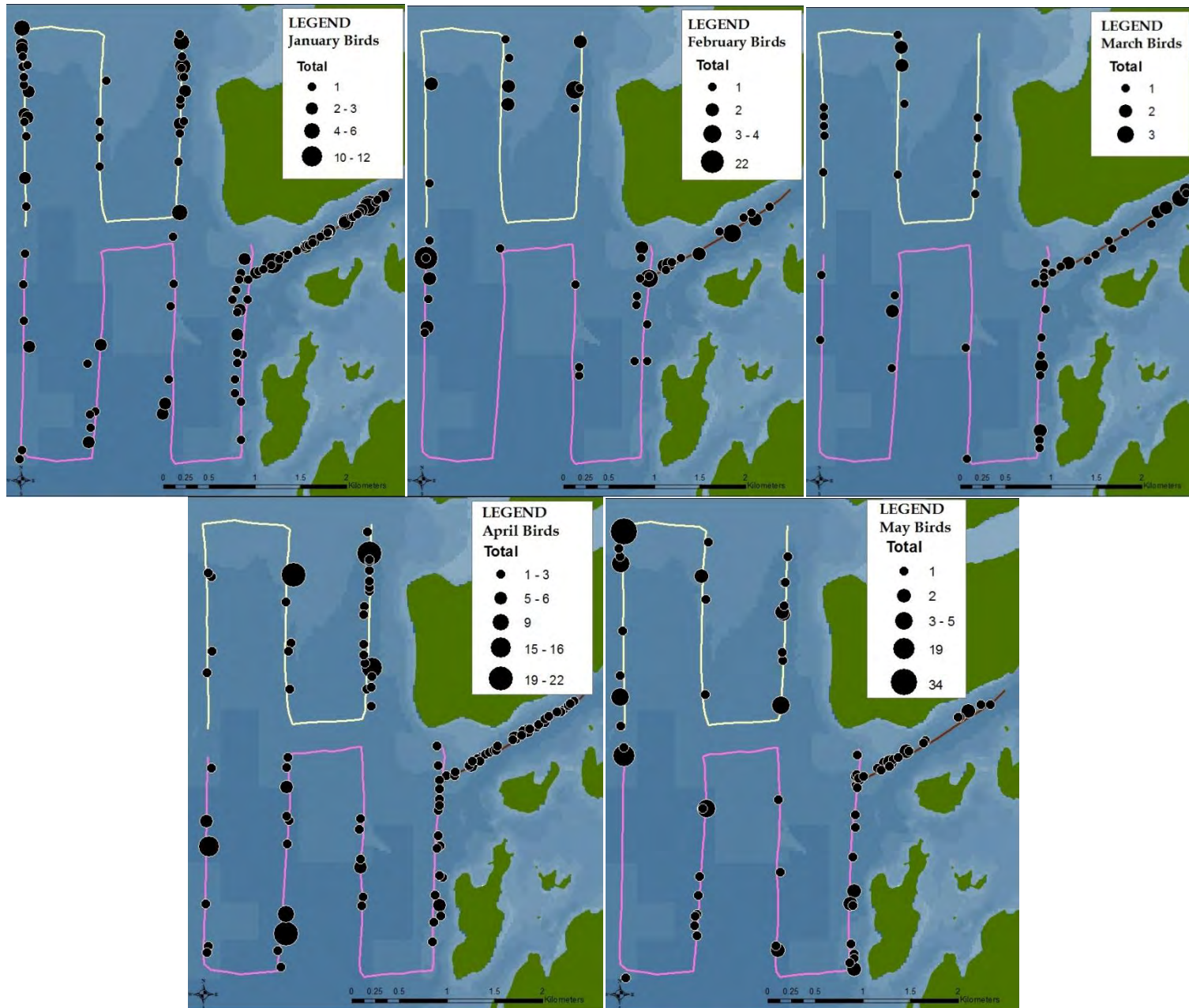
Map 19 Observations of wildlife during May 28 survey.

## ***B. Bird Species Abundance and Diversity, January-May 2014***

Of the 14 days, the greatest abundance of wildlife was observed on January 29<sup>th</sup> with 7.67/km<sup>2</sup> (Map 7), and the least abundance was on March 3<sup>rd</sup> with 1.09/km<sup>2</sup> (Map 10). Maps 20 a-e show overall distribution of all bird and other wildlife species throughout the 14 surveys, by month. All wildlife species observed within the Castine Test Site are presented in Tables 33 a, b, c, & d, in order of greatest density to least, according to quadrat. Herring gulls and COEI were the most common birds, found within the top three species across the three separate quadrats. Of the separate transects, the south quadrat had the greatest diversity of species, with 25 identified species of birds and three species of marine mammal, whereas the BR had 20 species of birds and one marine mammal, and the north quadrat had 19 bird species and two marine mammal species recorded.

Tables 33a, b, c, & d: Species, numbers and wildlife from most abundant to least. (a) Species abundance and densities for the overall total Castine Test Site; (b) the north quadrat; (c) south; (d) and Bagaduce River.

SPP	TOTAL	SPP	NORTH	SPP	SOUTH	SPP	BR
COEI	6.458	CANG	6.379	COEI	5.218	BLGU	33.125
HERG	6.202	COEI	6.379	HERG	4.490	COLO	19.375
COLO	5.435	HERG	6.034	COLO	3.398	HERG	15.625
BLGU	5.435	WWSC	5.862	SUSC	3.277	COEI	13.125
HSEAL	3.001	COLO	4.483	BLGU	3.155	MALL	9.375
CANG	2.685	LTDU	4.483	RNGR	2.184	UNDU	6.875
UNDU	2.685	UNDU	3.276	UNDU	1.456	ABDU	5
WWSC	2.558	RNGR	1.379	RAZO	1.456	COME	3.125
LTDU	2.366	UNAL	1.379	HSEAL	1.214	RNGR	3.125
RNGR	1.982	RAZO	1.207	LTDU	1.092	DCCO	2.5
SUSC	1.726	BLGU	1.034	UNAL	1.092	HSEAL	2.5
RAZO	1.407	BUFF	0.690	RTLO	0.850	RAZO	1.875
MALL	1.279	RBME	0.690	WWSC	0.728	LTDU	1.25
GSEAL	1.151	HSEAL	0.690	MALL	0.607	RBME	1.25
UNAL	1.087	COME	0.517	CANG	0.607	HOGR	1.25
RTLO	0.575	RBGU	0.517	HOGR	0.607	PEFA	1.25
COME	0.575	AMCR	0.517	RBGU	0.607	RTLO	0.625
HOGR	0.575	HOGR	0.345	DCCO	0.607	BUFF	0.625
DCCO	0.575	HAPO	0.345	AMCR	0.607	AMCR	0.625
AMCR	0.575	RTLO	0.172	HAPO	0.485	OSPR	0.625
ABDU	0.512	LAGU	0.172	TRSW	0.364	UNHA	0.625
RBME	0.512			RBME	0.243		
RBGU	0.512			LAGU	0.243		
BUFF	0.320			OSPR	0.243		
LAGU	0.192			COME	0.121		
TRSW	0.192			CORA	0.121		
OSPR	0.192			BAEA	0.121		
PEFA	0.128			GSEAL	0.121		
CORA	0.064						
BAEA	0.064						
UNHA	0.064						
HAPO	0.064						



Maps 20a-e. Observations of bird abundance by month, from January through May 2014.

## **C. Bird Behavior Categories**

Table 34 has the total numbers of all birds recorded in each quadrat, tallied by behavior. Sitting in the water was the most common behavior type recorded during the surveys throughout the entire Castine Test. Direct flight was the second most common activity.

Table 34. Abundance of each bird behavior type, by quadrat.

QUADRAT	Behavior Code							Total
	1	10	20	32	35	48	71	
N	126		114	2	3	6	13	264
S	168		85	1	4	10	8	276
BR	137	3	18		18	11	7	194
<b>Total</b>	<b>431</b>	<b>3</b>	<b>217</b>	<b>3</b>	<b>25</b>	<b>27</b>	<b>28</b>	<b>734</b>

### **1. SITTING ON THE WATER (Code #1)**

Throughout the surveys, 59% of all the recorded birds in the Castine Test Site were observed sitting on the water, which is a behavior category not meant to suggest or exclude feeding activity. This was the most common behavior observed overall. Behaviors described as ‘sitting’ may include sleeping, preening, or resting. In the north quadrat WWSC, COLO, and COEI were the top three species observed sitting (greatest to lesser); COEI, HERG & SUSC (tied), and BLGU were the top three in the south; and BLGU, COLO, and COEI were in the BR. The largest flock of sitting birds recorded during this survey season involved a single flock of 34 WWSC in the north quadrat during the morning of May 22<sup>nd</sup>. Of the five bird Order-Groupings, Group 1: Anseriformes (1A) represented 69% of the birds sitting on the water, followed by Group 2: Charadriiformes (31%) (2C).

### **2. FLYING BEHAVIORS**

Flight height and behavior were recorded in the three quadrats, and the following figures will show flight heights for the three most common flight behavior categories, separated into the north, south, and BR quadrats: Direct Flight, Milling, and Meandering.

#### **❖ a. Direct Flight (Code #20)**

Direct flight is described as a bird flying consistently through the area, not actively involved in foraging or other activities. The designation of this behavior during the survey is taken at the precise moment it is noticed by the surveyor.

Of all bird behaviors, direct flight was the second most common behavior observed throughout the entire Castine Test Site (29%) (Table 34). In the north quadrat, CANG, COEI & HERG (tied), and LTDU & UNDU (tied) were the top three species (greatest to lesser)

demonstrating direct flight; COLO, LTDU, and HERG were in the south quadrat; and BLGU, HERG, and common merganser (*Mergus merganser*; COME) & DCCO (tied) in the BR. In the north quadrat, 52% of these birds flew at or below one meter, 53% were at one meter in the south, and 78% flew at or below one meter in the BR quadrat (Figure 1).

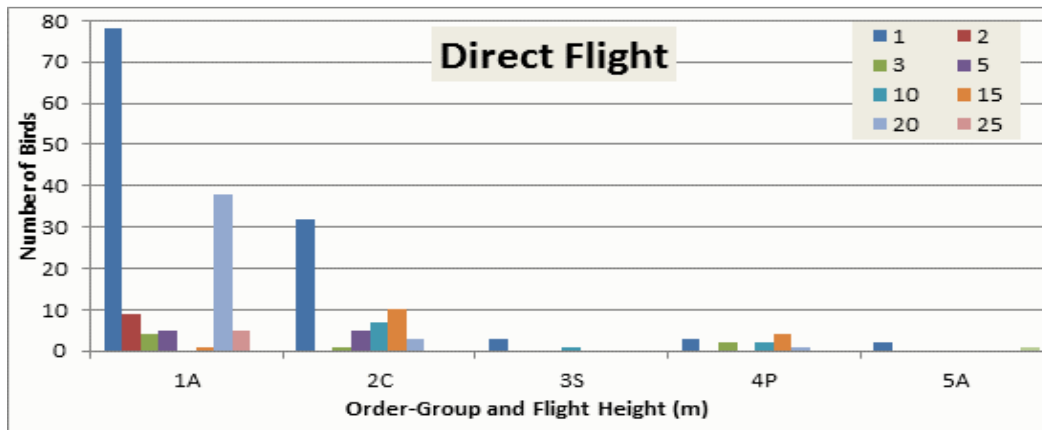


Figure 1. Numbers of bird species by Order-Group and flight height in Direct Flight.

❖ **b. Milling Flight (Code #35)**

Milling flight is described as a bird flying in a more distinct circling or milling path that is usually associated with foraging search patterns. Similar to meandering flight, general direction of milling flight constantly changes, thus flight direction is rarely noted in the survey data for these birds.

Of all bird behaviors, milling flight was tied as the second most common behavior in the BR, however only the fifth most common behavior observed in the north and south quadrats, as seen previously in Table 34. In the north and south quadrat HERG were the top species demonstrating milling flight; 12 mallards (*Anas platyrhynchos*; MALL) milled near the shore followed by six HERG within the BR. Of all quadrats, 88% of all milling occurred between 10-35m (Figure 2).

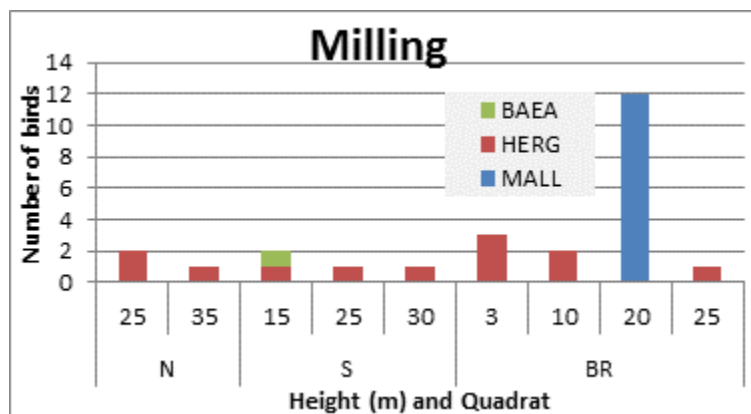


Figure 2. Numbers of bird species and flight height in Milling Flight.

❖ ***c. Meandering Flight (Code #48)***

Meandering flight is defined as a bird flying in a ‘wandering’ manner, not directly feeding or moving in any particular direction or with any obvious purpose. Flight direction constantly changes, thus flight direction is rarely noted in the survey data for these birds. The designation of this behavior during the survey is taken at the precise moment it is noticed by the surveyor.

Meandering flight was the third most common behavior in the south and BR quadrats, although it ranked as fourth in the north as seen in Table 34. All meandering occurred at or below 20m, although group 1A only meandered at or below five meters in only the south and BR quadrats and one American crow (*Corvus brachyrhynchos*; AMCR) meandered at 15m in the BR (Figure 3). The most abundant species for each quadrat were HERG in the north and BR and WWSC in the south.

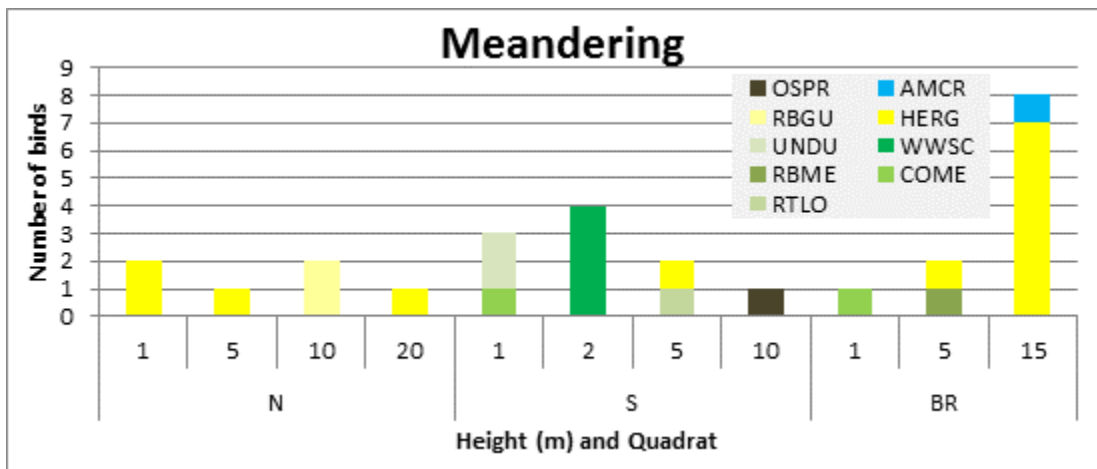
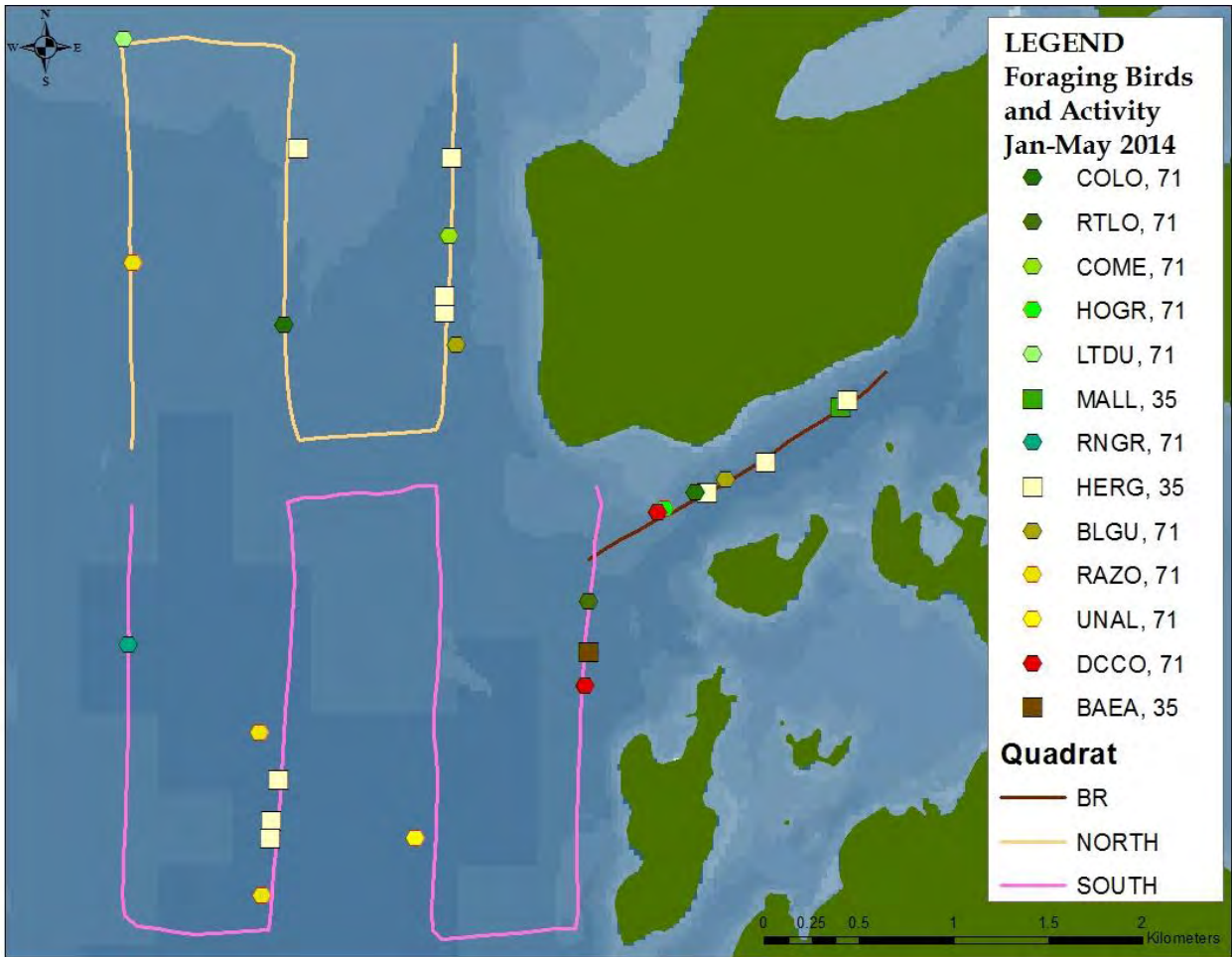


Figure 3. Numbers of bird species and flight height in Meandering Flight.

***3. FORAGING AND ALL OTHER BEHAVIORS***

The previous discussion focused on many behaviors that most likely are not associated with, or due to the brief period of the observed moment, cannot be determined as, foraging activities. Other behaviors are, however, evident activities that involve effort to forage for food either at the surface or below the water. Milling flight (#35) is a foraging behavior; it has been discussed in the previous section regarding flight behaviors but will be incorporated again in this section and combined with pursuit diving (#71). These two behaviors were the only foraging behaviors observed during this survey period.

For behavioral category comparisons, we will focus on the combination of the above-mentioned foraging behaviors in this following discussion. Figure 4 shows the locations of these foraging activities which involved only six percent of all bird behaviors in the north quadrat, four percent in the south, and 13% in the BR (Map 21).



Map 21. Location of foraging bird species throughout the season.

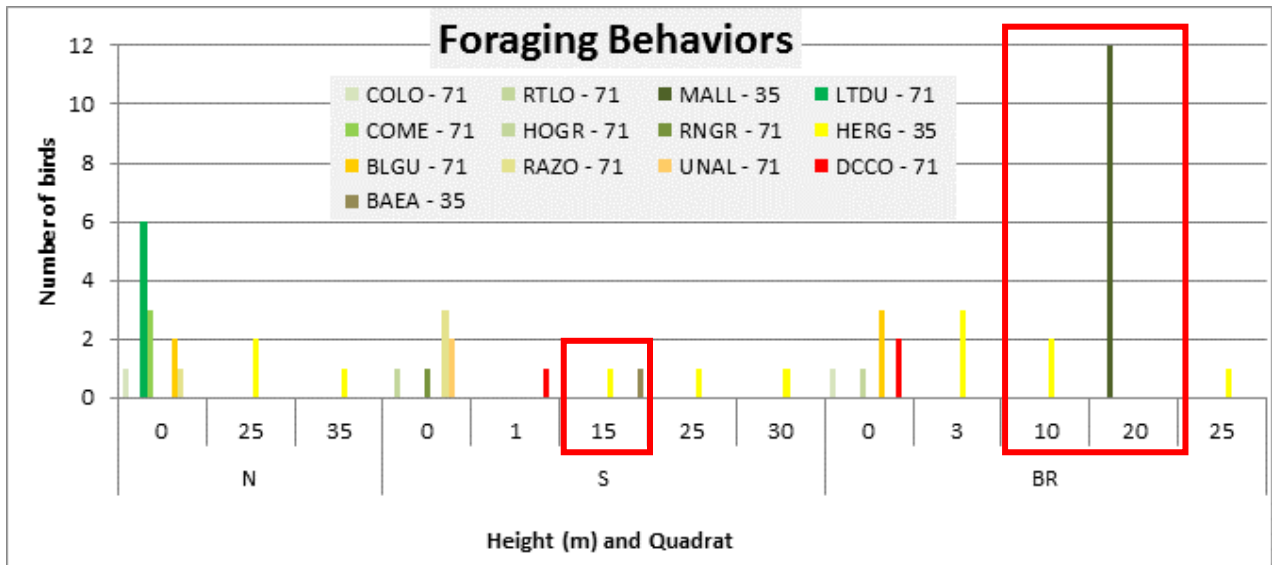


Figure 4. Numbers of foraging bird species and flight height by quadrat. The red boxes indicate birds within the RSZ of the turbine.

Throughout the overall Castine Test Site, most of the foraging activities were displayed by Group 1A (49%), followed closely by Group 2C (43%). Among these foraging species, 23% of the foraging birds were HERG and 23% were MALL. Of the milling foragers, the most frequented flight involved 48% flying at 20m.

Foraging activities often coincide with the presence of humans, and are commonly associated with the lobster and fishing industry that is prevalent in the GOM. Large gulls such as HERG, GBBG, and laughing gulls (*L. atricill*; LAGU) commonly search for easy, reliable foraging opportunities and therefore are attracted to vessels that commonly discard offal or bycatch (Schwemmer & Garthe 2005). Only three HERG ever displayed the behavior of “Following a Vessel” (code #32) and two were in the north quadrat and one was in the south, all at either five or 10m height. All three followed *our* research vessel.

#### **D. ENDANGERED, THREATENED, AND BIRDS OF CONSERVATION CONCERN**

There are two ESA-listed birds that have the potential to occur in the project area, but none were observed, or potentially observed, during these surveys: federally endangered roseate tern (*Sterna dougallii*), federally threatened piping plover (*Charadrius melodus*), and the red knot (*Calidris canutus*) that is a candidate species for federal listing. A number of bird species are also listed under the Maine ESA (MDIFW). In addition, the U.S. Fish & Wildlife Service (USFWS) created a list of species requiring special conservation action and awareness: the *Birds of Conservation Concern 2008* (BCC 2008). The MDIFW also has their list of species of special concern that identifies vulnerable species, which will be identified hereafter as SSC. Again, for ease of discussion when combining all special conservation designations, which contain federal, state, and concerning species, *SCC* will be used.

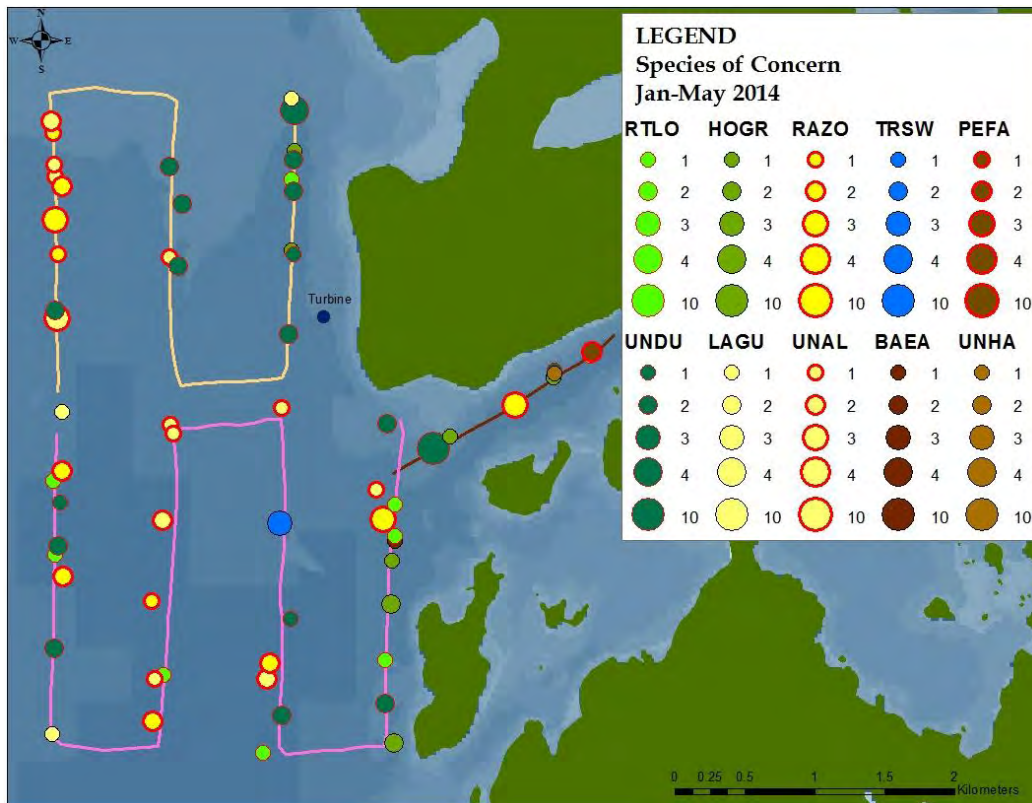
Bird species of these conservation designations are discussed in this following section and are shown in [Map 22](#). Previously, [Table 4](#) provided the list of all SCC observed during these surveys and include a total of 109 birds of these conservation designations. Observed during the Castine Test Site surveys from January 15 to May 28, 2014 only two State-Listed species were identified. They include 22 razorbills as State Threatened under the MDIFW’s Maine Endangered Species Act (MESA) of 1975, and two PEFA as State Endangered. Other observed species potentially falling into the State-Listed category were recorded as “unidentified duck” (n=42) and “unidentified alcid” (n=17). A selection of these species in this designation *that have the potential to occur within our survey area* include but are not limited to the harlequin duck (*Histrionicus histrionicus*); Arctic (*S. paradisaea*),



least (*S. antillarum*), and black tern (*Chlidonias niger*); and Atlantic puffin (*Fratercula arctica*).

Regarding the *Birds of Conservation Concern 2008* (BCC 2008) list, observed species of this designation included nine red-throated loons (*G. stellata*; RTLO), nine horned grebes (*P. auritus*; HOGGR), and one BAEA. Found on MDIFW’s SSC list were three LAGU and three tree swallows (*Tachycineta bicolor*; TRSW). Other observed species potentially falling into the SSC category were recorded as “unidentified duck” (n=42), “unidentified alcid” (n=17), and “unidentified hawk” (n=1). A selection of these species in this designation *that have the potential to occur within our survey area* include but are not limited to the some of which include the Barrow’s goldeneye (*Bucephala islandica*) and common murre (*Uria aalge*), of which may be found in our survey area.

Total numbers of every species per quadrat and density, and overall count and density, was presented in Table 3, with SCC denoted by red text. Unidentified ducks were the seventh most numerous of all birds identified (2.7 birds/km<sup>2</sup>), yet the most numerous of the SCC. Razorbills, second most abundant of SCC, were the twelfth most abundant bird species observed in the Castine Test Site overall, with 1.4 birds/km<sup>2</sup>. Within the north quadrat, 14% of the total bird count consisted of SCC (n=38; 0.33/km<sup>2</sup>), 18% comprised the south (n=51; 0.63/km<sup>2</sup>), and 10% were in the BR (n=20; 0.89/km<sup>2</sup>).



Map 22. Species of Conservation Concern observed throughout the entire survey season of 2014.

Seen below, [Figure 5](#) shows the summary of these species of concern and the behaviors they were observed performing. Four particular behavior types were observed by these SCC birds, which included the following: 71- underwater pursuit; 48- meandering; 35- milling; 20- direct flight; and 1- sitting on the water. Only the PEFA were observed with code 10-sitting on an object which happened to be the stone channel marker in which a pair of PEFA have nested in annually. Of these behaviors among the SCC birds, sitting on the water was the most common with 57% followed by direct flight (30%). Ninety-two percent of flying-associated behaviors by these SCC were at or below five meters ([Table 35](#)). Only one unidentified hawk flew at 45m in the BR, but only two birds were recorded as flying within the Rotor-Sweep Zone of 10-20m, which included one LAGU and one BAEA both at 15m in the south quadrat.

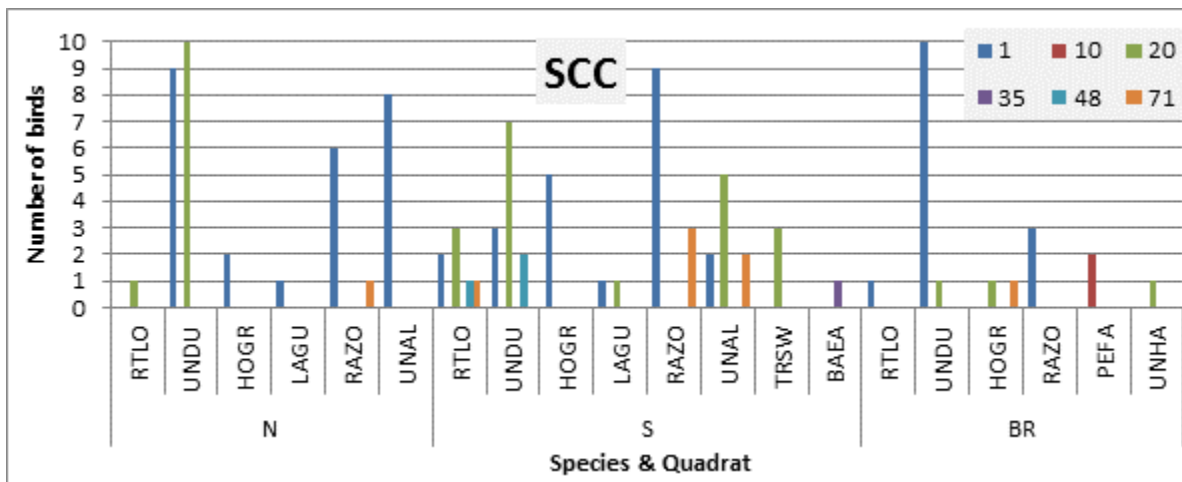


Figure 5. Behaviors displayed by SCC in each Quadrat.

Table 35. Flying behaviors and corresponding flight heights by SCC in each Quadrat.

BEHAVIOR	NORTH	SOUTH					BR		Grand Total
SPECIES	1	1	2	5	15	1	45		
<b>20- Direct Flight</b>									
RTLO	1	3						4	
UNDU	10	5	2			1		18	
HOGR						1		1	
LAGU					1			1	
UNAL		5						5	
TRSW		3						3	
UNHA							1	1	
<b>35-Milling</b>									
BAEA					1			1	
<b>48-Meandering</b>									
RTLO				1				1	
UNDU		2						2	
<b>Total</b>	<b>11</b>	<b>18</b>	<b>2</b>	<b>1</b>	<b>2</b>	<b>2</b>	<b>1</b>	<b>37</b>	

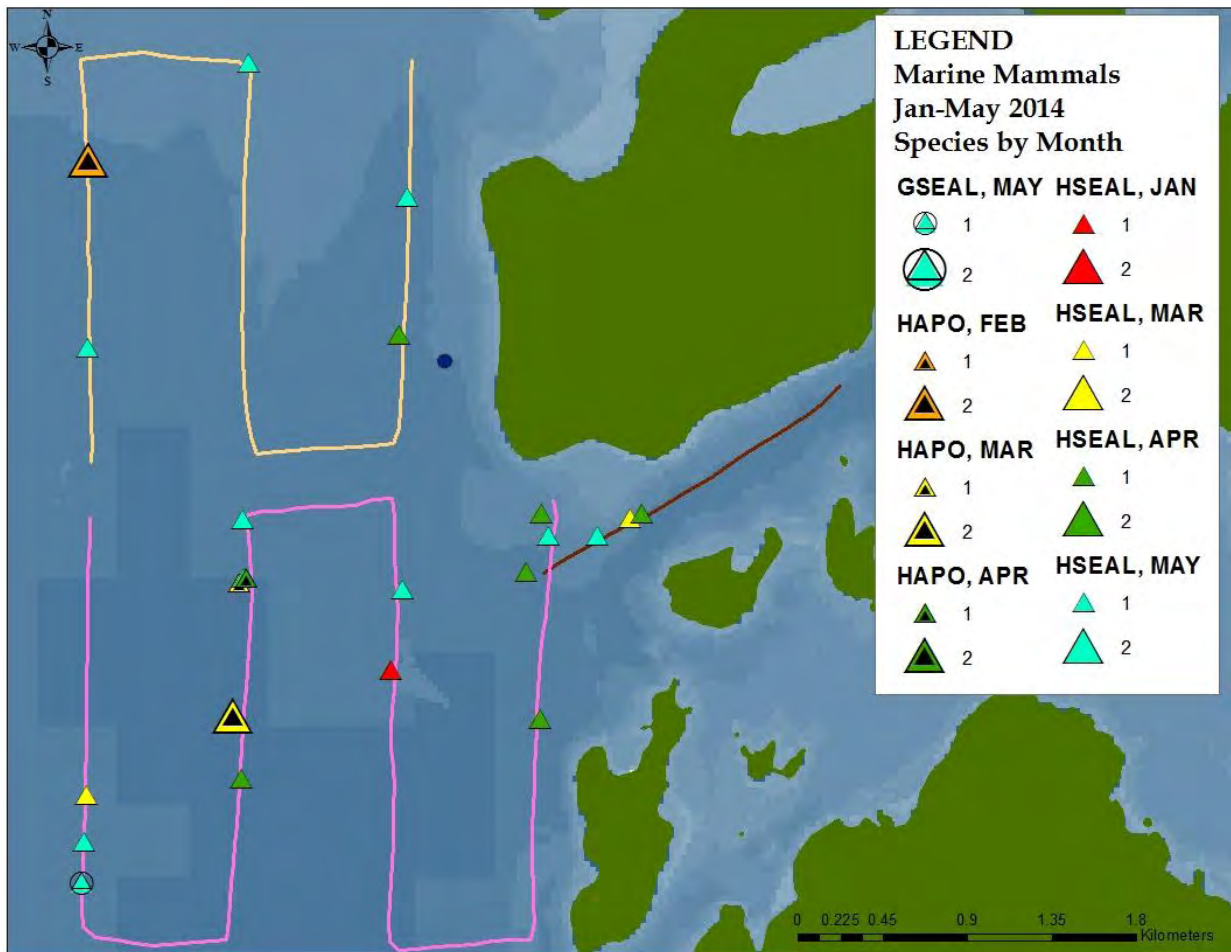
## E. MARINE MAMMALS & OTHER NON-BIRD SPECIES SUMMARY

A complete list of all species observed was provided in Table 3, summarizing the species and the dates on which they were documented. No baleen whales, large fish, or sea turtles were observed. Of the 14 survey days, harbor seals were observed on eight of them, totaling 3.0/km<sup>2</sup> (n=18) (Map 23). Only two gray seals were observed (0.005/km<sup>2</sup>), one each on August 14<sup>th</sup> and October 9<sup>th</sup>, and only in the south quadrat. Harbor porpoise were observed on 14 of the 17 days, totaling 0.16/km<sup>2</sup> (n=63).

Table 36 summarizes the seals and porpoise by quadrat. The harbor seal was the only marine mammal found in all three quadrats, the one gray seal was observed only in the south, and the harbor porpoise were only found in the north and south quadrats.

Table 36. Marine mammals by date and quadrat.

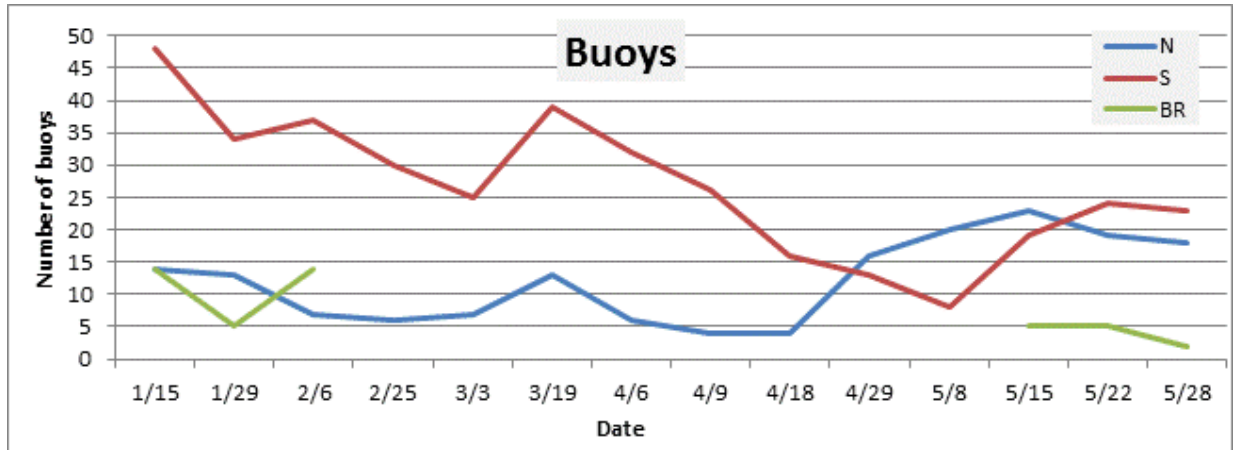
Species	North	South	BR	Total
HSEAL	4	10	4	18
GSEAL		1		1
HAPO	2	4		6
<b>Total</b>	<b>6</b>	<b>15</b>	<b>4</b>	<b>25</b>



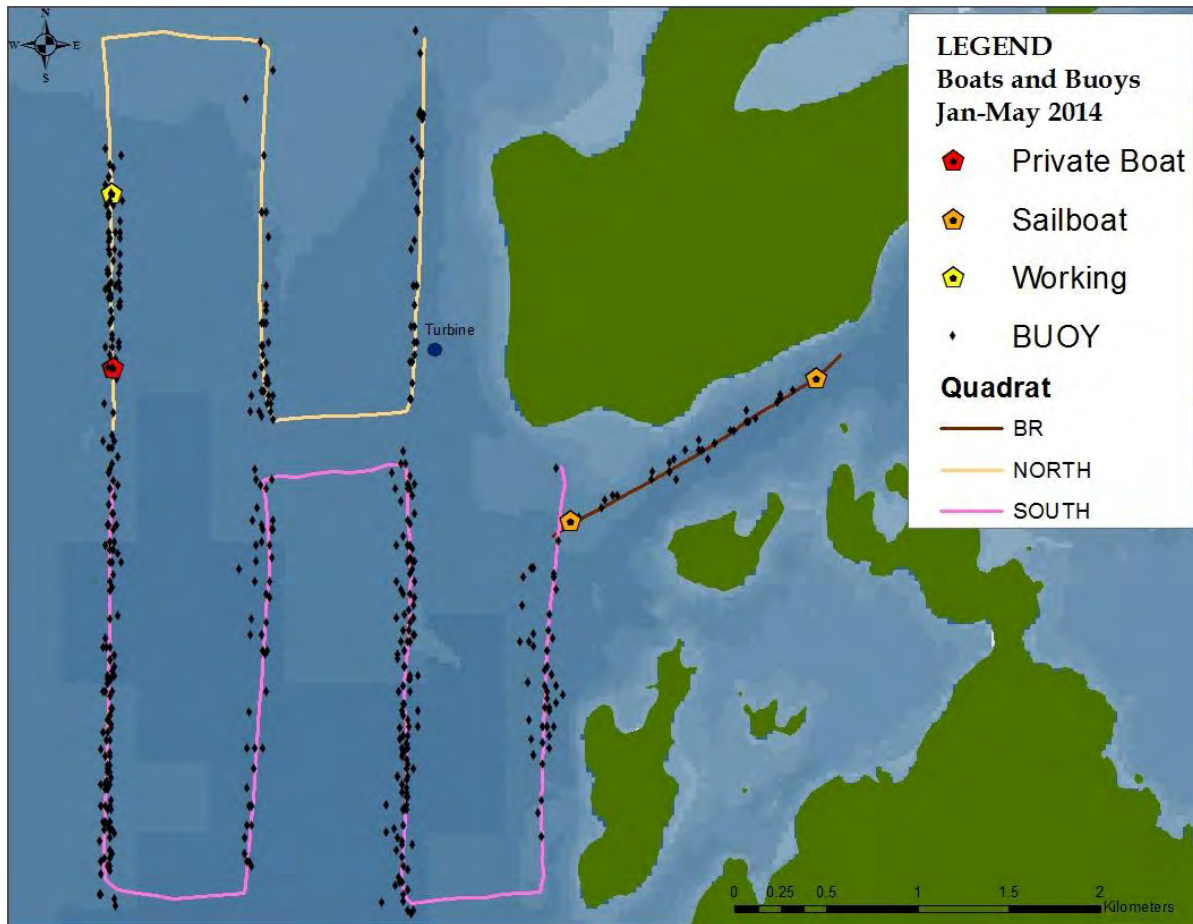
Map 23. Marine mammals observed.

## F. BOATS & BUOY OBSERVATIONS

Observations of boat traffic and lobster buoy presence were recorded during the surveys in 2014. A total of four boats were observed while surveys were performed, consisting of two sailing vessels in the BR and one working tugboat in the north and one private vessel in the north. [Figure 6](#) provides a breakdown of the buoy count in each of the quadrats. Numbers of buoys showed a slight decrease in particularly in the south quadrat as the season progressed, but buoy numbers disappeared altogether in the BR from early February until mid-May, and buoys in the north quadrat increased mid-April when buoys in the south had decreased. [Map 24](#) shows buoy concentrations throughout the entire season.



[Figure 6](#). Numbers of lobster buoys in each quadrat, by date.



Map 24. Buoy abundance across the entire survey season.

## VI. SUMMARY

January to May of 2014 included 14 boat-based visual surveys performed during the continuing deployment of the single 1/8<sup>th</sup> commercial scale VolturnUS 20kW wind turbine on a semi-submersible floating platform at the University of Maine’s Castine Harbor Dice Head Test Site. These surveys were performed initially at a rate of one every two weeks during January through March then increasing to one per week for the months of April and May. Data were gathered on species of birds and all other present wildlife such as marine mammals to include location, occurrence, numbers, behaviors, flight direction, and flight heights.

The previous sections of this report summarized the species numbers and activities by date and behavior categories, presented maps and tables of their sightings, and summarized species that are listed as a species of conservation designation, and other observations. Revisiting each of the project’s objectives, these following sections will further summarize the highlights of this season’s surveys.

***Objective #1: Determining bird and marine wildlife species compositions and their current activities and habitat use of the Castine Test Site.***

The overall count for individual birds throughout the entire Castine Test Site surveys was 734 and 25 marine mammals. In Part IV: Results, [Table 3](#) provided abundances, densities, and common behaviors of each survey quadrat's birds and marine mammals. Recorded in the north quadrat were a total of 17 identifiable species of birds (n=237), as well as an additional 19 unidentified ducks, eight unidentified alcids, and two species of marine mammals (n=6). The south quadrat had 23 identifiable species of birds (n=255), with an additional 12 unidentified ducks, nine unidentified alcids, and three marine mammals (n=15). The Bagaduce River quadrat had only 19 identified species of birds (n=182), and an additional 11 unidentified ducks, one unidentified hawk, and one marine mammal species (n=4), but overall density was the greatest of the three quadrats.

Twenty-six identifiable species of birds were documented throughout the entire Castine Test Site. Although total abundance of each species ranked COEI, HERG, COLO, and BLGU as the top four species in order of greatest to lesser (previously in [Table 33a](#)), densities per square kilometer show only HERG and COEI listed as ranking within one of the top four species across all three quadrats, yet distributed in varying order of abundance ([Tables 33b, c, & d](#)). [Figure 7](#) shows the Order-Grouping distribution across the season, by date. Group 2: Charadriiformes increased in abundance from the start of the season to mid-season; Group 1: Anseriformes peaked and dropped sporadically throughout the season; and Group 3: Suliformes reappeared by late April.

The most common avian activities observed throughout the entire Castine Test Site were sitting (59%), followed by direct flight (29%) and these behaviors were also the two most commonly observed throughout the separate quadrats (previously in [Table 34](#)). The next most common behaviors varied in each of the quadrats. Forty-six percent of all flying heights occurred at one meter but 35% of birds flew within the Rotor-Sweep Zone between 10-20m, as indicated in the red box in [Figure 8](#).

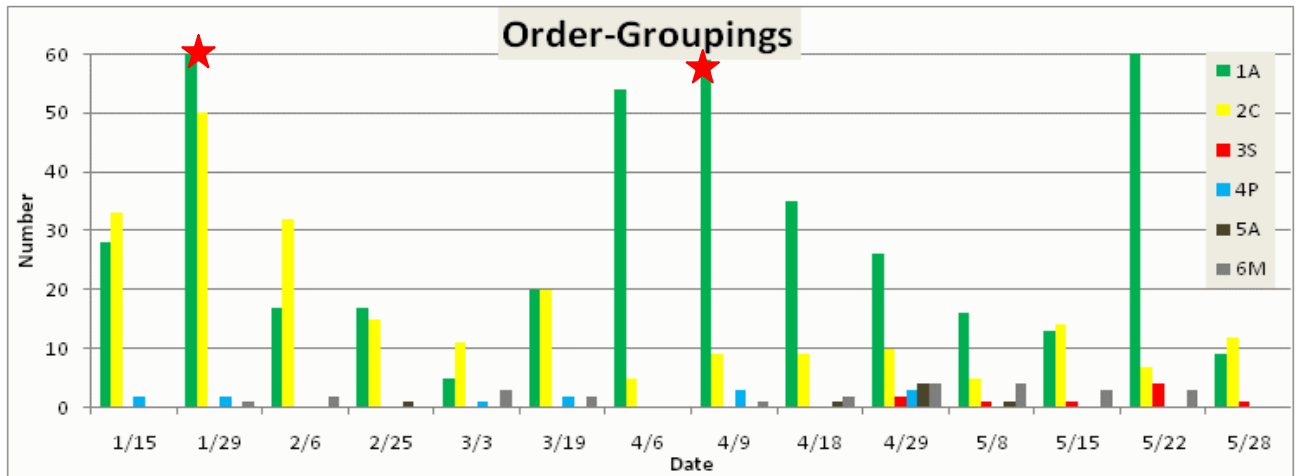


Figure 7. Numbers of wildlife in Order-Groupings, by date. The red stars indicate 68 birds in Group 1A on Jan 29 and 105 birds in Group 1A on April 9.

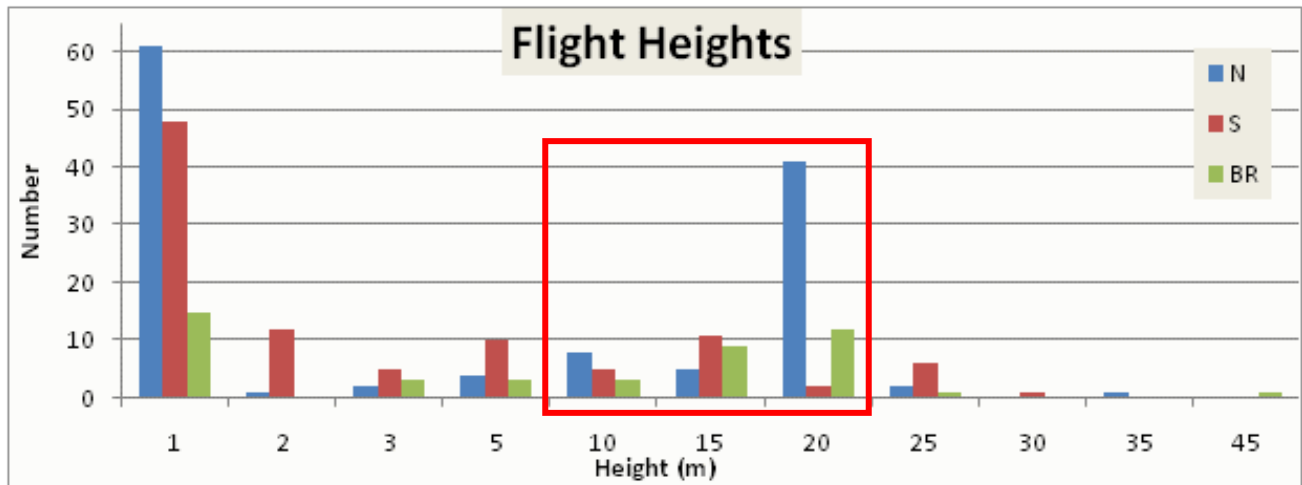


Figure 8. Flight heights of all flying birds throughout the season. Red box indicates Rotor-Sweep Zone.

Bird Order-Groupings revealed only a few notable differences among behaviors observed. Within both Groups 1A and 2C, the vast majority of the birds sat in the water (63% and 57%, respectively). The next most common behavior for these groups involved direct flight, with 1A mostly flying at one meter and 20m, and 2C mostly at one meter and 15m. Group 4P all flew direct, with 33% flying at 15m. Figure 9 shows each species group and their typical behaviors and flight heights.

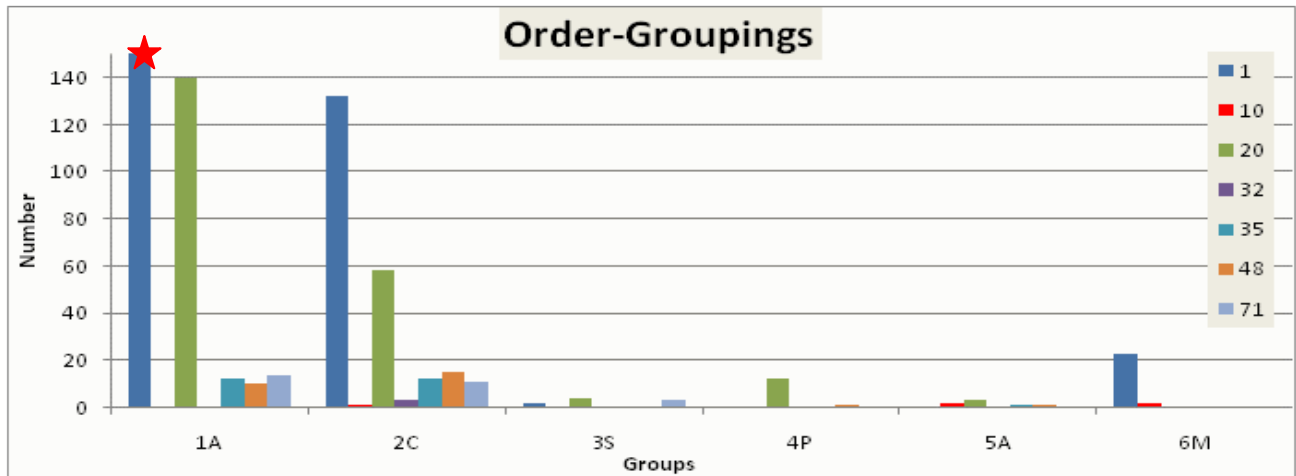


Figure 9. Behavior types of all wildlife by Order-Groupings throughout the season. The red star indicates 197 birds in Group 1A sitting on the water (code #1).

In summary of foraging behaviors across the four major Order-Grouping represented in this survey, a higher percentage of foraging birds were found in the BR quadrat (47%), followed by the north quadrat (30%). Of these foraging birds, 49% consisted of Group 1A, followed closely by 2C with 43%. As seen previously in [Map 21](#) the greater variety of bird species were found along the south quadrat’s eastern-most line and greater abundances were found along the north quadrat’s eastern-most line. This is very likely attributed to the nearness to land and greater foraging opportunities, which is also the likely factor to the greater abundance of foragers found in the BR.

Endangered, threatened, and Birds of Conservation Concern (SCC) sightings included two PEFA (StE), 22 razorbills (StTh), and potential State-Threatened species identified as unidentified ducks (n=42) and unidentified alcids (n=17). Other identified MDIFW SSC species included three LAGU, three TRSW, one BAEA, and one unidentified hawk. The USFWS BCC list included observations of nine RTLO and nine HOGH. Within the north quadrat, 14% of the total bird count consisted of SCC, 18% comprised the south, and 10% were in the BR. Unidentified ducks were the most abundant of the SCC followed by unidentified alcids. Of the flying SCC, 92% were recorded at or below five meters.



***Objective #2: Use on-going baseline inventory of the species composition, behaviors, and habitat use to assess potential risks to the wildlife in relation to the VoltturnUS 1/8<sup>th</sup> scale turbine at the Castine Test Site.***

Although four previous studies have been conducted at this Monhegan Test Site, they will neither be discussed nor compared to the results of this current survey.

Birds may experience four major types of impact caused by offshore wind farms: direct collision, displacement due to disturbance, displacement due to the barrier effect, and direct habitat loss (Drewitt & Langston 2006, Goodale & Divoll 2009). A fifth impact involves habitat enhancement due to the underwater structure acting as an artificial reef and potentially attracting piscivorous seabirds; however this can only be a net benefit if the birds are not frightened away or killed by the structure itself (Drewitt & Langston 2006). In the case of the Castine Harbor Dice Head Test Site, the 1/8<sup>th</sup> scale structure, and the data presented in this portion of the project, is relatively small in both spatial and temporal contexts. Nevertheless, discussion will follow that summarizes any potential impact that the single 20kW 1/8<sup>th</sup> scale test turbine on a floating platform may present to wildlife at the University of Maine's Castine Test Site.

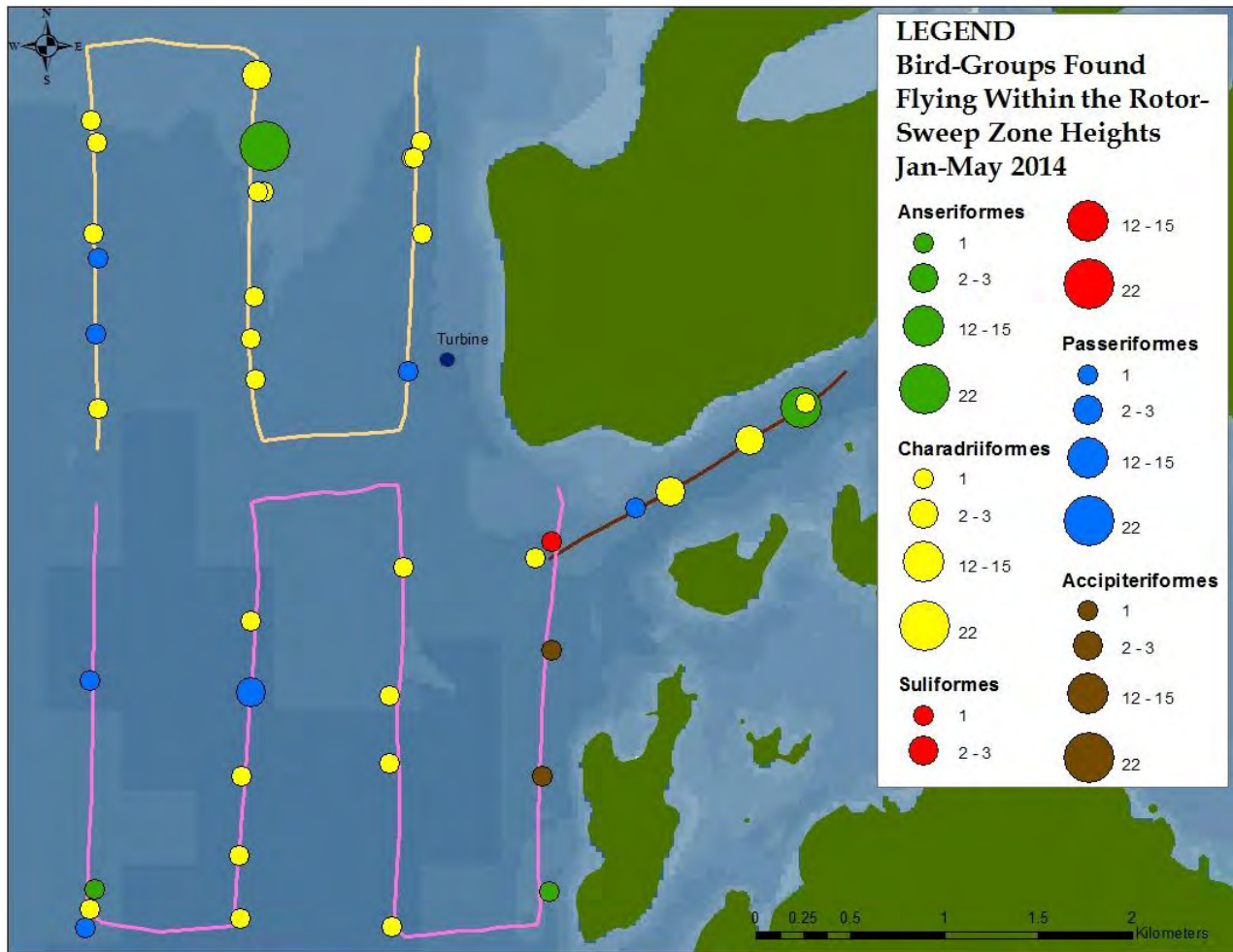
Current literature discusses how the probability of impacts from wind turbines, particularly with collisions, is more dependent upon individual species and their unique behaviors (Drewitt & Langston 2006, Ferrer et al. 2012, Fox et al. 2006, Furness & Wade 2012). These considerations should also take into account the local topographic factors which influence wind patterns and prey availability, as opposed to the common investigation of local abundance (Ferrer et al. 2012); together these factors influence the behavior of the individual birds at that moment in time.

More frequently, lighter winds blow through the upper Penobscot Bay area where the turbine is located, and although 11 of the 14 survey days found the blades in motion during our surveys, in many cases the blades were very slowly spinning. This minimizes the potential impact of injury or death with a swiftly moving object through the air. It is widely understood, however, that birds are documented as colliding with a wide variety of stationary man-made objects. These have included lighthouses, bridges, windows, high wires, etc., and flying birds particularly become susceptible under poor visibility and environmental conditions (Fox et al. 2006).

Numerous Wind farm Sensitivity Index (WSI) studies in Europe and North America generally agree that the species most affected by offshore wind farms include gulls, grebes, loons, seaducks, and migrating waterfowl and passerines (Drewitt & Langston 2006, Garthe

& Hüppop 2004). Radar studies at a Danish location revealed significant avoidance behavior (by a factor of 4.5) within the wind farm array by geese and common eider, and increasing their distance to the turbines, thereby reducing the risk of collision (Desholm & Kahlert 2005). A newer analysis by Furness & Wade categorized impacts to particular species, concluding high disturbance scores for common eider, loons, and scoter species because they are easily disturbed and have a high tendency to flush; high collision impact scores for gulls, terns, and loons; and high overall disturbance and displacement scores for loons, sea ducks, and alcids (Furness & Wade 2012). Common eider was the most abundant species observed throughout the Castine Test Site, with numbers significantly peaking on Apr 9th, followed by COLO, whose numbers remained more consistently abundant. Only two sightings of a flock of CANG appeared, both in April, with 37 and five, respectively. Of the A1: Anseriformes, 53% flew in the north quadrat, which is the quadrat in which the VoltturnUS turbine is located. Because of these findings, eider, loons, geese, and duck species could experience a minor risk of collision, although the probability is likely not highly significant.

Flight height was determined to be a substantial factor in assessing collision probabilities by Furness & Wade in their review of Scottish seabird sensitivity to offshore wind farms (2012). It is discussed by Dierschke and Daniels that over 90% of loons, sea ducks, gulls, and terns habitually fly higher over the ocean (at or below 50m) and are more likely to be at the heights at which this turbine's blades would be spinning, thereby putting them more at risk (Dierschke & Daniels 2003 *in* Furness & Wade 2012). The single VoltturnUS 20kW wind turbine on a 1/8<sup>th</sup> commercial scale semi-submersible floating platform that was deployed on June 6, 2013 has a hub height measuring 50ft (15.24m), with a rotor diameter of 31.5ft (9.6m) and RSZ between 10-20m. For purposes of bird collision and other risks, it is necessary to consider the Castine Test Site avian flight activity in this flight height-zone, regardless of the blades spinning or not. Bird species found flying at this height included geese, loons, mallards, gulls, cormorants, corvids, an eagle, and an osprey, totaling 35%. Of birds within Group 1A, 49% flew at one meter, and only 12% flew within the RSZ. A red box indicates flying birds found within the 10- to 20m zone in both Figure 4 (for foragers) and Figure 8 (all flying birds). Within this RSZ, foraging species involved three HERG, one BAEA, and 12 MALL, totaling 62% of all foraging birds. When reviewing the locality of these birds within the north quadrat, as seen in Map 25, the abundance and distribution of birds being at risk from the slowly rotating turbine blades is again likely minimal. Within our 10 species of conservation status, only the single BAEA and one LAGU (of three total LAGU) were documented as flying within the rotor-sweep zone of 10- 20m above the water. This is a minimal portion of the SCC to be affected by collision with the spinning blades or its structure and therefore not of great concern.



Map 25. Birds flying within the 10-20m Rotor-Sweep Zone of the 1/8<sup>th</sup> scale VoltturnUS semi-submersible floating turbine.

Other seasonal factors should objectively be considered in the analyses regarding behaviors of gulls, terns, sea ducks, and cormorants that are described as susceptible to disturbance by turbines (Drewitt & Langston 2006, Fox et al. 2006). With the Bagaduce River Watershed and the Holbrook Island Sanctuary in the near vicinity of this Castine Test Site, it is essential that breeding bird species are given particular consideration for their use of this “Focus Area of Ecological Significance” (BwH 2012). Of the 25 bird species from our survey that were also identified on the “Checklist of the Birds” for the Holbrook Island Sanctuary, 10 of these are known to breed in the area (Holbrook Island Sanctuary, 2001). However, due to the timing of these surveys occurring from winter through early spring, this is not a factor that has concern for these species.

At a study of ecological changes at a windfarm off the shore of the Netherlands, numbers of gulls, terns, and cormorants increased as the birds actively used the area for foraging (Lindeboom et al. 2011 *in* Furness & Wade 2012). A similar increase in gulls and

terns at the Horns Rev windfarm was also documented (Petersen et al. 2004 *in* Fox et al. 2006). Although the cause was not clear regarding the increased numbers of HERG and terns at the Horns Rev wind farm in Denmark post construction (Drewitt & Langston 2006), explanation may have included increased loafing structures, increased fish abundance due to habitat modification, increased boat traffic looking like potential food sources, or a combination of any of these factors (Fox et al. 2006). For this reason, gulls in the Castine Test Site could be attracted to the turbine itself for a loafing structure, or for potentially increased foraging opportunities resulting from either increased boat traffic, or if the underwater structures and sea floor anchor disturbance create ideal habitat for fish, thereby increasing foraging piscivorous bird species (Fox et al. 2006).

Breaking down the north quadrat into the three transect lines, only two BLGU and three COME foraged underwater and two HERG milled with one each at 25m and 35m in the “N3,” which is the closest to the floating turbine. **Of all the species found within the north quadrat, only the HERG comprised 25% in the north compared to other quadrats. These abundances provide little concern for gulls being attracted to the turbine area in search of foraging opportunities. Other species involved 2:5 BLGU, 1:2 COLO, 3:3 COME, 6:6 LTDU, and 1:4 RAZO found within the entire north quadrat compared to the other quadrats. Reviewing Map 21 provides these species’ locality compared to the turbine which shows only the BLGU, HERG, and COME were in the “N3” strip nearest the turbine while foraging.** Underwater pursuit presents the least danger to birds regarding a turbine; therefore the BLGU and COME are at minimal risk. The two milling HERG could potentially suffer from collision, however they were both flying above the RSZ at the time of observation.

Gulls are well known for investigating boats for the opportunity of finding easy food from discards (Schwemmer & Garthe 2005); this likely accounts for the three gulls that were observed following our survey vessel. One occurred in the south quadrat (“S3”), and two in the north, located specifically within strips “N1” and “N3.” Again, these numbers reveal a minimal cause for concern regarding the phenomenon of the turbine structure or increased human boat activity attracting these species of birds to the VoltturnUS 1/8<sup>th</sup> scale turbine.

In summary of this January to May of 2014 survey it is theoretically possible to suggest that our SCC are out of harm’s way regarding direct impact due to collision or attraction due to habitat enhancement. Common eider, HERG, COLO, BLGU, and CANG were recorded as the five most abundant species during our surveys (Table 33a). Of these species, when comparing our study to these previous studies, it appears that there is minimal concern regarding these species’ activities near the Castine Test Site. **Only due to the greater incidence of flight heights of foragers within the RSZ (62%) are our gulls, BAEA, and duck species at the most at risk for collision impacts with the structure. However, as**

outlined by further data, these birds showed a minimal use of the north quadrat possibly due to the spinning structure (in motion 11 of the 14 survey days), thereby reducing the concern for collision.

The sea ducks, loons, and cormorants counted in this study totaled 350 birds at 1.6/km<sup>2</sup> over the 14 survey days. According to the literature, they are at most risk for impacts due to disturbance, attributable to being easily flushed and strongly demonstrating significant avoidance behavior of the human structures, therefore perpetuating the loss of habitat near wind farms (Furness & Wade 2012, Larsen & Guillemette 2007). This however is a minor disturbance in our case of this small-scale Castine project, and the effects are likely minimal.

Although abundance alone is not a factor of concern for impact to the birds of the University of Maine's VoltturnUS 1/8<sup>th</sup> scale Test Turbine Site, the consistently higher numbers of gulls observed during this season's surveys will continue to be an interesting subset of data to observe. Due to carcasses sinking or being consumed by opportunistic predators, detection probabilities are low for birds that may be killed by collision, *if* they do occur with this single 20kW 1/8<sup>th</sup> scale floating turbine.

Maine-specific considerations for wind farm development have been suggested by the BioDiversity Research Institute to include three main criteria: 1) avoid critical breeding, wintering, and migratory areas, 2) avoid offshore islands that provide breeding areas for seabirds and are essential migratory staging areas, and 3) avoid areas within three kilometers (1.86mi) of these first two criteria to prevent serious impact to birds of special concern (Goodale & Divoll 2009). The Castine area is near the Holbrook Island Sanctuary and the Bagaduce River Watershed, renowned for its Essential Habitat status (BwH 2012) for many species of birds that include BAEA, OSPR, DCCO, and various ducks and waterfowl. Within this vicinity of the Castine Test Site, the breeding species observed during our surveys included DCCO, ABDU, MALL, HERG, BLGU, COEI, OSPR, BAEA, and AMCR, and TRSW. Of these birds, only the one BAEA (BCC & SSC), and three TRSW (SSC) are considered a SCC and they were only ever recorded from within the south quadrat and in small numbers.

In summary, it is advised that surveys continue to be performed year round and continue as long as the University of Maine's VoltturnUS floating test turbine is present. This is to best evaluate the ongoing effects and/or habituation that may occur, with particular consideration given to changes in avian species composition, abundance, and behavior that could be attributed to the presence of the test turbine. These surveys are one of the first known studies of pre-deployment species composition and behavior for an offshore floating wind turbine with a tension leg design. They are essential to an understanding of

the impact of alternative energy development projects, therefore streamlining their appropriate use and cooperatively mitigating the resulting impacts will benefit both humans and seabirds within this next decade.

## **ACKNOWLEDGEMENTS**

I would sincerely like to thank Maine Maritime Academy and the dedicated captain Erin Bostrom, as well as the supporting deck hands and staff, whose accommodating spirit and generosity has made this project feasible. Additional support and mentoring is owed to Gordon Longfellow at the College of the Atlantic. The most thanks goes to Dr. Damian Brady Russell Edgar, and Donna Darling for their logistical, professional, and encouraging support. They are the catalysts that keep a worthy project afloat. Thank you.

# APPENDIX 1

## SURVEY CODES

(Gould & Forsell 1989)

### Code 2. Survey Type (15)

- 1 = General observations: These are records of large flocks, rare or unusual sightings, transects that cannot be used to derive density indexes, or any record that will not fit another format.
- 7 = Station count: The criteria for a station count are that the platform is stationary and that all birds are counted in a 360° circle from the platform.
- 9 = Ocean transect: The criteria for a transect are a visibility of at least 1,000m and a moving platform with a constant speed and direction. An oceanic-transect is conducted outside well-defined headlands.

### Code 3. Observation Conditions (75)

- 1 = Bad (general observations only)
- 2 = Poor (no quantitative analysis)
- 3 = Fair
- 4 = Average
- 5 = Good
- 6 = Excellent
- 7 = Maximum

### Code 5. Sea State (49)

- 0 = Calm
- 1 = Rippled (0.0 1-0.25 ft)
- 2 = Wavelet (0.26-2.0 ft)
- 3 = Slight (2-4 ft)
- 4 = Moderate (4-8 ft)
- 5 = Rough (8-13 ft)
- 6 = Very rough (13-20 ft)
- 7 = High (20-30 ft)
- 8 = Over 30 ft

### Code 6. Weather (55-56)

- 00 = Clear to partly cloudy (0-50% cloud cover)
- 03 = Cloudy to overcast (51-100% cloud cover)
- 41 = Fog (patchy)
- 43 = Fog (solid)
- 68 = Rain
- 71 = Snow
- 87 = Hail

### Code 14. Age (32)

- P = Pullus (flightless young)
- J = Hatching year (hatching date to spring molt: a bird capable of sustained flight)
- S = Subadult (last year before adult plumage)
- A = Adult

### Code 17. Bird Behavior (56-57)

- 00 = Undetermined
- 01 = Sitting on water
- 10 = Sitting on floating object
- 15 = Sitting on land
- 20 = Flying in direct & consistent heading
- 29 = Flying, height variable
- 31 = Flying, circling ship
- 32 = Flying, following ship
- 34 = Flying, being pirated
- 35 = Flying, milling or circling (foraging)
- 48 = Flying, meandering
- 61 = Feeding at or near surface while flying (dipping or pattering)
- 65 = Feeding at surface (scavenging)
- 66 = Feeding at or near surface, not diving or flying (surface seizing)
- 70 = Feeding below surface (pursuit diving)
- 71 = Feeding below surface (plunge diving)
- 82 = Feeding above surface (pirating)
- 90 = Courtship display
- 98 = Dead

### Code 18. Mammal Behavior (56-57)

- 00 = Undetermined
- 01 = Leaping
- 02 = Feeding
- 03 = Mother with young
- 04 = Synchronous diving
- 05 = Bow riding
- 06 = Porpoising
- 07 = Hauled out
- 08 = Sleeping
- 09 = Avoidance
- 14 = Curious/following
- 15 = Cetacea/pinniped association
- 16 = Pinniped/bird association
- 17 = Cetacea/bird association
- 18 = Breeding/copulation
- 19 = Moribund/dead

## APPENDIX 2: Species codes, Latin name, dates, abundances, and densities.

2014		JANUARY		FEBRUARY		MARCH		APRIL				MAY					
SPP	Latin name	1/15	1/29	2/6	2/25	3/3	3/19	4/6	4/9	4/18	4/29	5/8	5/15	5/22	5/28	Total	
COLO	<i>Gavia immer</i>	8		6	1		7	7	6	9	10	11	7	4	9	85	5.43
RTLO	<i>G. stellata</i>	3	2	1	1					1			1			9	0.58
MALL	<i>Anas platyrhynchos</i>		13				2		5							20	1.28
ABDU	<i>A. rubripes</i>	4	4													8	0.51
BUFF	<i>Bucephala albeola</i>	2		3												5	0.32
LTDU	<i>Clangula hyemalis</i>		13		9	2	2		11							37	2.37
COME	<i>Mergus merganser</i>	5				1					3					9	0.58
RBME	<i>M. serrator</i>		7	1												8	0.51
CANG	<i>Branta canadensis</i>							37	5							42	2.69
COEI	<i>Somateria mollissima</i>					1	3	6	69	16	5		1			101	6.46
SUSC	<i>Melanitta perspicillata</i>									3	5			19		27	1.73
WWSC	<i>M. fusca</i>								1				4	35		40	2.56
UNDU			14	4	5		1	2	6	4	2	2		2		42	2.69
HOGR	<i>Podiceps auritus</i>	3					3					3				9	0.58
RNGR	<i>P. grisegena</i>	3	15	2	1	1	2	2	2	2	1					31	1.98
HERG	<i>Larus argentatus</i>	11	13	25	4	3	3	1	2	3	2	2	12	7	9	97	6.20
LAGU	<i>L. atricilla</i>	1	1	1												3	0.19
RBGU	<i>L. delawarensis</i>	1		1		4			1			1				8	0.51
BLGU	<i>Cephus grille</i>	8	15	5	8	4	15	4	5	6	8	2	2		3	85	5.43
RAZO	<i>Alca torda</i>	4	16		2											22	1.41
UNAL		8	5		1		2		1							17	1.09
DCCO	<i>Phalacrocorax auritus</i>										2	1	1	4	1	9	0.58
AMCR	<i>Corvus brachyrhynchos</i>	2	2				2		3							9	0.58
CORA	<i>C. corax</i>					1										1	0.06
TRSW	<i>Tachycineta bicolor</i>										3					3	0.19
BAEA	<i>Haliaeetus leucocephalus</i>				1											1	0.06
OSPR	<i>Pandion haliaetus</i>									1	1	1				3	0.19
PEFA	<i>Falco peregrinus</i>										2					2	0.13
UNHA											1					1	0.06
	<b>Bird Total</b>	<b>63</b>	<b>120</b>	<b>49</b>	<b>33</b>	<b>17</b>	<b>42</b>	<b>59</b>	<b>117</b>	<b>45</b>	<b>45</b>	<b>23</b>	<b>28</b>	<b>71</b>	<b>22</b>	<b>734</b>	<b>3.35</b>
	<b>per km2</b>	4.03	<b>7.67</b>	3.13	2.11	<b>1.09</b>	2.69	3.77	7.48	2.88	2.88	1.47	1.79	4.54	1.41	46.93	
HSEAL	<i>Phoca vitulina</i>		1				2		1	1	4	4	2	3		18	3.00
GSEAL	<i>Halichoerus grypus</i>												1			1	1.15
HAPO	<i>Phocoena phocoena</i>			2		3				1						6	0.06
	<b>Marine Mammal Total</b>	<b>0</b>	<b>1</b>	<b>2</b>	<b>0</b>	<b>3</b>	<b>2</b>	<b>0</b>	<b>1</b>	<b>2</b>	<b>4</b>	<b>4</b>	<b>3</b>	<b>3</b>	<b>0</b>	<b>25</b>	<b>0.38</b>
	<b>per km2</b>	0.00	0.06	0.13	0.00	0.19	0.13	0.00	0.06	0.13	0.26	0.26	0.19	0.19	0.00	1.60	



## LITERATURE CITED

- Beginning With Habitat. (2012) "Focus Areas of Statewide Ecological Significance: Bagaduce River," 5 pp. [http://www.maine.gov/doc/nrimc/mnap/focusarea/bagaduce\\_river\\_focus\\_area.pdf](http://www.maine.gov/doc/nrimc/mnap/focusarea/bagaduce_river_focus_area.pdf)
- Berleant, A. "\$1 million grant for Bagaduce River arrives with strings attached." *Castine Patriot*, April 5, 2012.
- Biodiversity Research Institute (2012). "Birds, Bats, and Coastal Windfarm Development in Coastal Maine: Preliminary Ranking of Bird Use." *Biodiversity Research Institute*. Retrieved July 29, 2012, from <http://www.briloon.org/oae/the-science-of-bri/tracking-wildlife/birds-bats-costal-windfarm-development>
- Drewitt, A.L. and R.H.W Langston. 2006. Assessing the impacts of wind farm on birds. *Ibis* 148: 29-42.
- Ferrer, M., M. de Lucas, G.F.E. Janss, E. Casado, A.R. Muñoz, M.J. Bechard, and C. P. Calabuig. 2012. Weak relationship between risk assessment studies and recorded mortality in wind farms. *Journal of Applied Ecology* 49: 38-46.
- Fox, A.D. M. Desholm, J. Kahlert, T. K. Chritensen, I.B.K. Petersen. 2006. Information needs to support environmental impact assessment of the effects of European marine offshore wind farms on birds. *Ibis* 148: 129-144.
- Furness, B. & H. Wade. 2012. Vulnerability of Scottish Seabirds to Offshore Wind Turbines. MacArthur Green Ltd., Glasgow. 39pp.
- Garthe, S. and O. Hüppop. 2004. Scaling possible adverse effects of marine wind farms on seabirds: developing and applying a vulnerability index. *Journal of Applied Ecology* 41: 724-734.
- Goodale, W. and T. Divoll. 2009. Birds, Bats and Coastal Wind Farm Development in Maine: A Literature Review. Report BRI 2009-18. BioDiversity Research Institute, Gorham, Maine.
- Gould, P.J. & D.J. Forsell. 1989. Techniques for shipboard surveys of marine birds. U.S. Fish & Wildlife Service, *Fish & Wildl. Technical Report* 25, 22 pp.
- Kennedy, L. & Holberton, R.L. 2012. "Visual Observations for Birds, Turtles, and Marine Mammals at the University of Maine Test Site off Monhegan Island, a report submitted to the Maine State Planning Office and University of Maine." Submitted January 2012. 52pp.
- Larsen, J.K. and M. Guillemette. 2007. Effects of wind turbines on flight behaviour of wintering common eiders: implications for habitat use and collision risk. *Journal of Applied Ecology* 44: 516-522.
- Maine's Department of Inland Fisheries & Wildlife (MDIFW) Endangered Species Program/Bird List [http://www.maine.gov/ifw/wildlife/species/endangered\\_species/bird\\_list.htm](http://www.maine.gov/ifw/wildlife/species/endangered_species/bird_list.htm)
- MDIFW Species of Special Concern. (<http://www.maine.gov/ifw/wildlife/endangered/specialconcern.htm#birds>)

- Maine Tidal Power Initiative's Site Resource Assessment (2011). Published Habitat Map: Bagaduce Narrows and Castine Harbor, Maine. "Significant Wildlife and Essential Habitats." *University of Maine: Maine Tidal Power Initiative*. Retrieved from the Maine DEP website: [http://www.maine.gov/dep/gis/datamaps/index.html#nrpa\\_bird](http://www.maine.gov/dep/gis/datamaps/index.html#nrpa_bird)
- Schwemmer, P. and S. Garthe. 2005. At-sea distribution and behavior of a surface-feeding seabird, the lesser black-backed gull *Larus fuscus*, and its association with different prey. *Marine Ecology Progress Series*. 285: 245-258.
- Tasker, M.L., P.H. Jones, T. Dixon, & B.F. Blake. 1984. Counting seabirds at sea from ships: A review of methods employed and a suggestion for a standardized approach. *The Auk* 101: 567-577.
- USFWS Species of Conservation Concern 2008 (U.S. Fish and Wildlife Service. 2008. Birds of Conservation Concern 2008. United States Department of Interior, Fish and Wildlife Service, Division of Migratory Bird Management, Arlington, Virginia. 85 pp. [Online version available at <https://www.fws.gov/migratorybirds/NewReportsPublications/SpecialTopics/BCC2008/BCC2008.pdf>]
- USFWS (January 9, 2012). **Guidance regarding use of the Wind Turbine Guidelines Advisory Committee's recommendations.** *Wind Turbine Guidelines Advisory Committee: Habitat and Resource Conservation*. Retrieved September 23, 2012, from [http://www.fws.gov/habitatconservation/windpower/wind turbine advisory committee.html](http://www.fws.gov/habitatconservation/windpower/wind_turbine_advisory_committee.html)

# Visual Observations for Birds, Turtles, and Marine Mammals at the University of Maine Test Site near Castine, Maine.



*A report submitted to the University of Maine's Advanced Structures  
and Composites Center*

*SEPTEMBER - OCTOBER 2014*

*by*

**LAURA KENNEDY, MS**

*Lubird Kennedy Environmental Services*

Bar Harbor, Maine

[lubirdkennedy@yahoo.com](mailto:lubirdkennedy@yahoo.com)

918-549-5625

# TABLE OF CONTENTS

Executive Summary .....	1
I. Introduction .....	2
II. Location.....	4
III. Methods.....	7
IV. SEPTEMBER - OCTOBER 2014 Results .....	10
A. Surveys by day .....	14
1. Sept 3 Survey, morning .....	14
2. Sept 9 Survey, afternoon.....	16
3. Sept 17 Survey, morning .....	18
4. Sept 23 Survey, morning .....	20
5. Oct 1 Survey, afternoon .....	22
B. Species Abundance and Diversity.....	24
C. Bird Behavior Categories.....	26
1. Sitting .....	26
2. Flying Behaviors .....	26
a. Direct Flight Behavior .....	26
b. Milling Flight Behavior.....	27
c. Meandering Flight Behavior .....	28
3. Foraging & Other Behaviors .....	28
D. Endangered, Threatened, and Birds of Conservation Status.....	31
E. Marine Mammals .....	33
F. Boats & Buoys .....	35
V. Summary .....	37
A. Objective #1 .....	37
B. Objective #2 .....	40
VI. Acknowledgements .....	45
VII. Literature Cited .....	48

## TABLES:

Table 1. Most common behavior codes .....	9
Table 2. Surveys by time of day and corresponding weather conditions .....	10
Table 3. Species codes, scientific names, and densities.....	11
Table 4. Species of conservation concern designation .....	12
Table 5. Number of species Sept 3.....	14
Table 6. Species by quadrat, behavior, and height, Sept 3 .....	14
Table 7. Number of species Sept 9.....	16
Table 8. Species by quadrat, behavior, and height, Sept 9 .....	16
Table 9. Number of species Sept 17.....	18
Table 10. Species by quadrat, behavior, and height, Sept 17 .....	18
Table 11. Number of species Sept 23.....	20
Table 12. Species by quadrat, behavior, and height, Sept 23 .....	20
Table 13. Number of species Oct 1 .....	22
Table 14. Species by quadrat, behavior, and height, Oct 1 .....	22
Table 15a-d. Species abundances from greatest to lesser, total area and by quadrats.....	24
Table 16. Abundance of each behavior type, by quadrat .....	26
Table 17. Marine mammals by date and quadrat.....	33
Table 18. Vessel type observed throughout the Castine Test Site.....	35

## MAPS:

Map 1.	Castine and Penobscot Bay in Maine with survey tracks .....	2
Map 2.	Location of the Castine Test Site .....	3
Map 3.	Bagaduce River Watershed .....	5
Map 4.	New England Tidal Power Initiative Map of Significant Wildlife and Essential Habitats .....	6
Map 5.	Castine Test Site survey track lines.....	8
Map 6.	Sept 3 observations .....	15
Map 7.	Sept 9 observations .....	17
Map 8.	Sept 17 observations .....	19
Map 9.	Sept 23 observations .....	21
Map 10.	Oct 1 observations .....	23
Map 11 a,b.	Distribution of bird abundance totals & across five surveys during September to October 2014 .....	25
Map 12	Foraging birds throughout the season .....	30
Map 13.	Species of Conservation Concern throughout the season.....	32
Map 14.	Marine mammals throughout the season .....	34
Map 15.	Boats and buoys .....	36
Map 16.	Birds flying within the Rotor-Sweep Zone (10-20m) .....	42

## FIGURES:

Figure 1.	Direct flight heights by Order-Group.....	27
Figure 2.	Milling flight heights by Order-Group .....	28
Figure 3.	All foraging flight heights by quadrat .....	29
Figure 4.	Species of Conservation Concern behaviors.....	33
Figure 5.	Numbers of lobster buoys by quadrat and date.....	35
Figure 6.	Bird Order-Group abundances by date .....	38
Figure 7.	All flight heights.....	38
Figure 8.	Behavior types by Order-Group .....	39

## APPENDICES:

Appendix 1: Behavioral codes (Gould & Forsell 1989) .....	46
Appendix 2: Species code, scientific name, dates, abundances, and densities.....	47

## Public Use Statement

This report contains data collected through federal funds provided by the University of Maine's Advanced Structures and Composites Center (Ct-07B-20111024\*2017). While the information provided in this report is meant for public access, permission is required to reproduce figures, tables, and any other product contained within this report without the express permission of the University of Maine's Advanced Structures and Composites Center.

Suggested citation for this report:

Kennedy, L. 2014c. "Visual Observations for Birds, Turtles, and Marine Mammals at the University of Maine Test Site near Castine, Maine; September - October 2014. A report submitted to the University of Maine's Advanced Structures and Composites Center. "

## Executive Summary

Five boat-based surveys were conducted from September to 1 October 2014 at the University of Maine's Castine Harbor Dice Head Test Site near Castine, Maine. The primary objective is to record baseline pre-deployment observations of seabirds and other wildlife at this location. Observations included species, number, behavior, flight height and direction, as well as weather and sea conditions. The secondary objective is to use this information to assess potential risk or behavior conflicts that may occur due to the presence of the VoltturnUS 20kW wind turbine on a 1/8th commercial scale floating platform and its operations and maintenance.

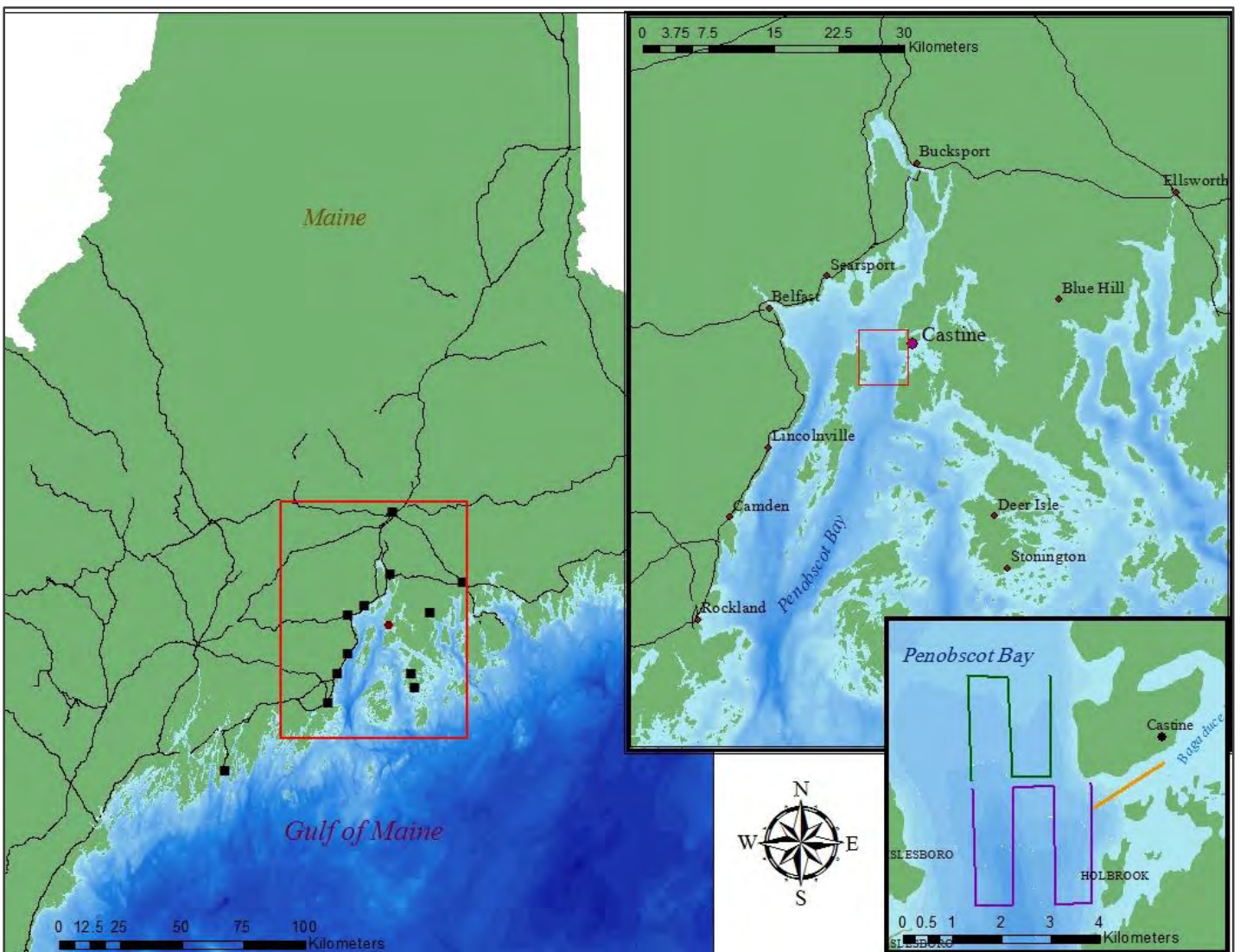
Throughout these five surveys within this period, 559 birds were recorded and 22 marine mammals. The four most prevalent bird species were herring gull (*Larus argentatus*, HERG; n=294, 17.97/km<sup>2</sup>), black guillemot (*Cepphus grille*, BLGU; n=44, 6.7/km<sup>2</sup>), Bonaparte's gull (*Chroicocephalus philadelphia*; BOGU; n=58, 6.2/km<sup>2</sup>), and double-crested cormorant (*Phalacrocorax auritus*; DCCO; n=27, 4.97/km<sup>2</sup>). Great cormorants (*P. carbo*; GRCO) were the only identified state-threatened species of concern (n=2, 0.098/km<sup>2</sup>) in the area, although a single flock of 12 unidentified shorebirds that may or may not have been a Federally or State Threatened species were also recorded. Six other identified species of concern with a USFWS or MDIFW conservation designation were recorded.

The most common bird behaviors included sitting (48%) followed by direct flight (19%). Forty-eight percent of all flying heights occurred at one to three meters but 27% of birds flew within the Rotor-Sweep Zone (RSZ) between 10-20m. Of SCC behaviors, sitting on the water was the most common (24%) followed closely by pattering (23%) and direct flight (22%). Forty-two percent of flying-associated behaviors by these SCC were at or below three meters. Thirty-four percent (n=24) of all SCC were recorded as flying within the RSZ of 10-20m, yet only the single flock of 10 red-throated loons (*Gavia stellata*; RTLO) flew within a potentially dangerous vicinity of the floating turbine whereas all other SCC birds were found in the south or BR quadrats.

Although the test turbine is small-scale and this particular set of surveys consisted of only five days, RTLO and common loons (*G. immer*; COLO) were found more often in the north quadrat. Ranked highly susceptible to disturbance and collision in other windfarm studies, both RTLO and COLO may be at risk at this Castine Test Site. Ten foraging ring-billed gulls (*L. delawarensis*) scavenged while sitting also near the turbine. Generally, gulls and terns are believed to be highly affected by turbines due to collision or attracted for foraging opportunities, however in our study, only the RBGU were potentially in a susceptible area near the turbine and posing a small concern for their safety.

# I. INTRODUCTION

The Gulf of Maine (GOM) is a well-known avian corridor for the millions of songbirds, raptors, shorebirds, wading birds, and waterfowl to pass through during the spring and fall migration (Goodale & Divoll 2009). Over 300 documented species of all major avian taxa frequent the GOM region and more data is currently being accumulated that supports a growing list of known-wintering species. For the purposes of this report, our area of focus lies near Castine, ME midway along Maine's coast at the mouth of the Penobscot River, in Penobscot Bay (Map 1).

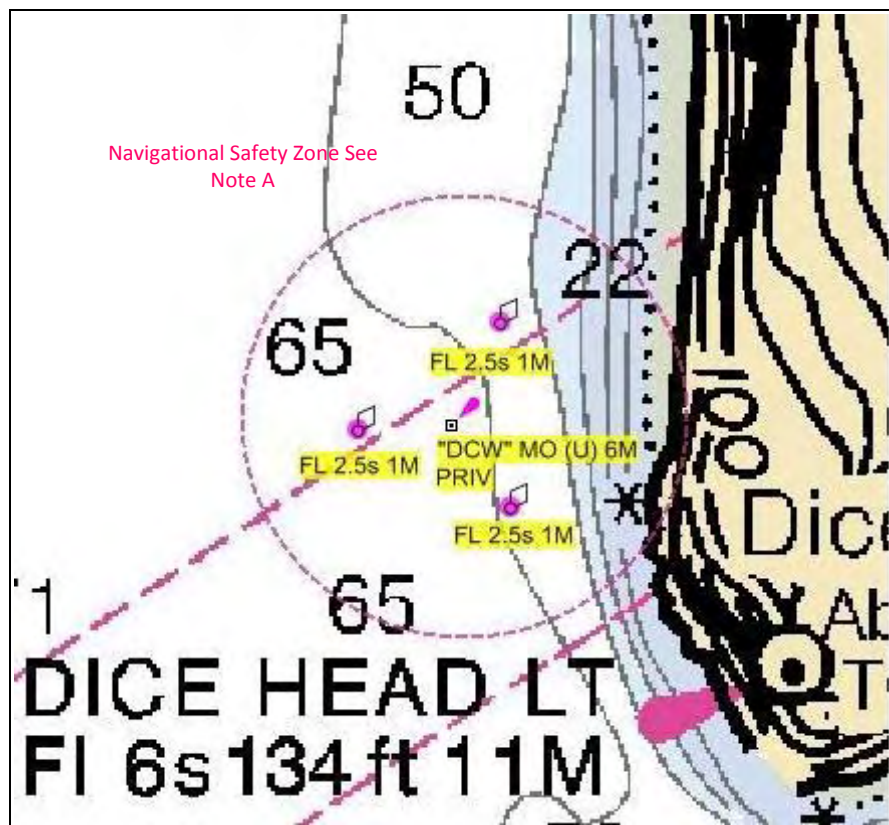


Map 1. Castine and Penobscot Bay in Maine, with survey region inside the smaller red box in inset maps.



This survey was initiated as a request for pre- and during-deployment data at the Castine Test Site to be used in the environmental assessment for DeepCwind’s VoltturnUS 1/8 scale turbine test unit on a semi-submersible floating platform. Specific information pertaining to the flight heights, behaviors, and species found near the Dice Head Lighthouse area helps to better understand the birds’ habitat use of the site (e.g., feeding, resting, and passing through the area). It also helps to assess potential risks as a result of human activities associated with the siting, construction, operation, and removal of turbine structures. Resource agencies such as the Maine Department of Inland Fisheries and Wildlife (MDIFW) and the United States Fish and Wildlife Service (USFWS) consider monitoring bird activity with respect to offshore wind development a high priority (USFWS Wind Turbine Guidelines Advisory Committee, 2012).

The location of the VoltturnUS 1/8th scale semi-submersible floating platform turbine is found at N44°23’8”, W68° 49’ 32” in the waters 1,000ft (305m) off Dice’s Head at Castine, Maine, in an existing cableway (Map 2).



Map 2. Location of Castine Test Turbine Site near Castine, Maine. Map courtesy of University of Maine’s Navigation Safety Plan, D.Chase.

The primary objectives of this study include 1) determining bird and marine wildlife species compositions and their current activities and habitat use of the Castine Harbor Dice Head Test Site, and 2) using this information to assess potential risk or behavior conflicts that may occur due to the presence of the University of Maine's VoltturnUS 20kW wind turbine on a 1/8<sup>th</sup> commercial scale floating platform and its operations and maintenance. Data will assess species composition and behavior changes, if any, to the presence of the structure. These risks will include potential collision with both above and below surface structures such as blades and platform anchoring lines, or the use of the platform structure for wildlife to roost upon. Other potential behavioral conflicts may arise due to the operational boat traffic and other sources of increased human presence, or additional structure presence.

This report summarizes ongoing baseline data of the VoltturnUS turbine's deployment at the University of Maine's Castine Test Site that occurred as of June 6, 2013. The structure consists of a single 20 kW test turbine that measures 20m tall (65.6ft) at the highest blade tip, sitting on a floating tension leg platform and connects to the electric grid via an underwater cable. The rotor diameter measures 31.5ft (9.6m), creating a Rotor Sweep Zone (RSZ) from 10m to 20m from the water's surface.

## II. LOCATION

Castine lies on the west side of the Blue Hill peninsula and on the north-west bank of the Bagaduce River, which is a 12-mile (19.3km) stretch of flowing tidal water that converges into Penobscot Bay. The BioDiversity Research Institute ([www.briloon.org](http://www.briloon.org)) has created a Ranking of Bird Use map that categorizes areas from High to Low bird use. The numerous islands that lie at the outer edge of Penobscot Bay, particularly on the tip of the Blue Hill Peninsula, have a concentrated zone of High bird use. Further up the bay, however, near Castine and in the area surveyed in this report, bird use rates as "Low" (BRI, 2012).

Two important areas of this region of the Blue Hill Peninsula and Penobscot Bay are considered "Significant Wildlife Areas": the Bagaduce River watershed and Holbrook Island Sanctuary.

Like the GOM region, the Penobscot Bay region contains important and diverse ecosystems for many species of birds, invertebrates, fish, and shellfish, largely due to the Bagaduce River's ecological significance (Map 3). Because of this abundance of wildlife and habitat, the Bagaduce River Watershed has been designated by the Beginning with Habitat (BwH) organization ([www.beginningwithhabitat.org](http://www.beginningwithhabitat.org)) as a "Focus Area of Statewide

Ecological Significance” that includes Significant Wildlife Areas for Inland Wading Bird and Waterfowl Habitat, Tidal Wading bird and waterfowl habitat, and Significant Shorebird Area (BwH, 2012). Map 3 shows the location of the VoltturnUS 1/8<sup>th</sup> scale floating test turbine site, which is not inside the Bagaduce River watershed, but is in the vicinity.



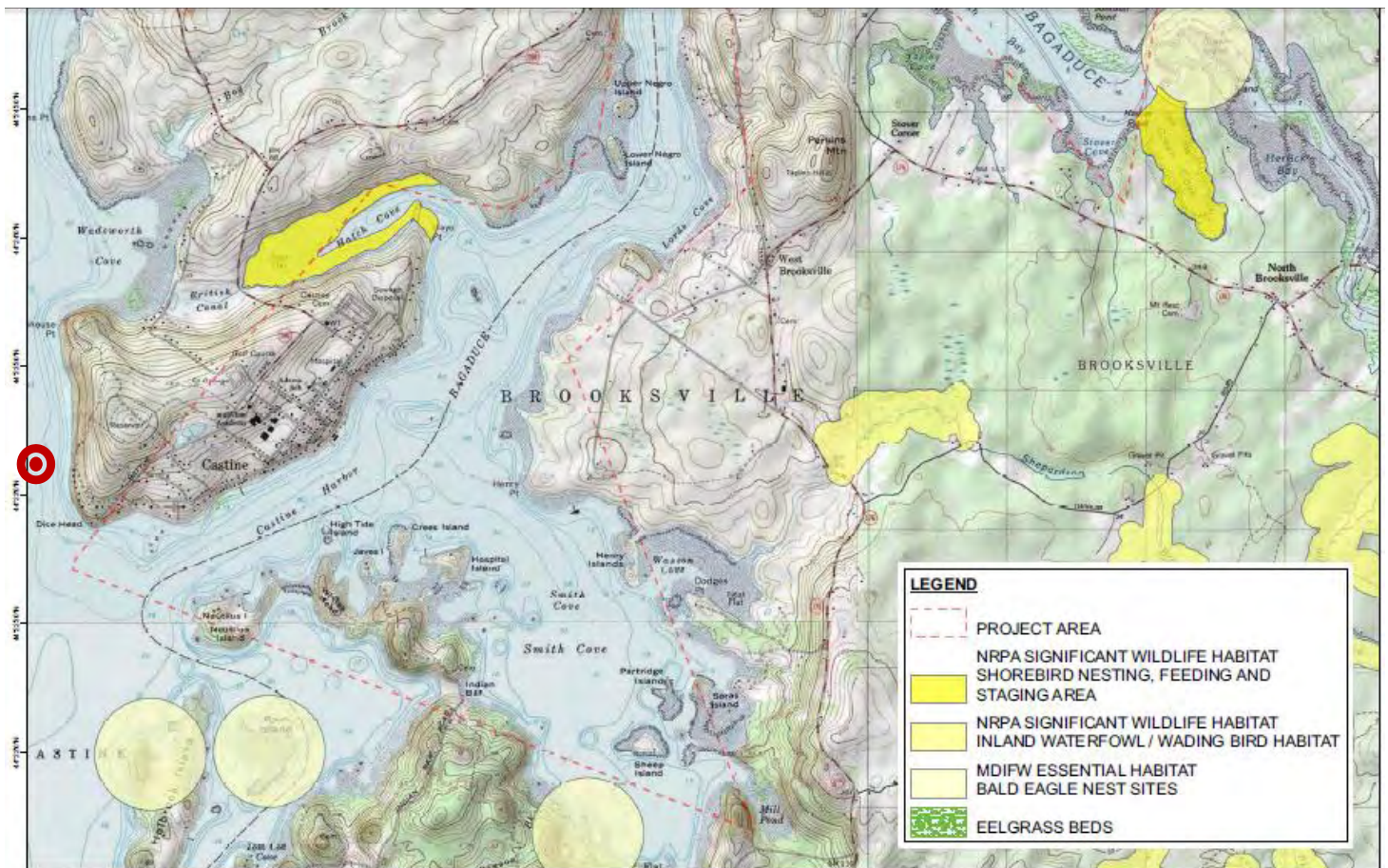
Map 3. The Bagaduce River Watershed. Map courtesy of *Beginning With Habitat* ([www.beginningwithhabitat.org](http://www.beginningwithhabitat.org)). The purple circle represents the Castine Harbor Dice Head Turbine Test site location.

Not only is the area of the Bagaduce River’s 2,700 acres available for waterfowl and wading birds’ feeding, breeding, and migratory stopover, but it is also one of a few locations in Maine where American horseshoe crabs (*Limulus polyphemus*) are known to breed (BwH, 2012). In April of 2012, the Maine Coast Heritage Trust received a large federal matching grant to further wetland habitat conservation and land protection efforts in the Bagaduce River watershed due to its important bird habitat status (Berleant 2012). Due to the shallow open waterways and strong tides that help resist freezing in the winter, migrating and wintering waterfowl take refuge in the protected coves of the river.

In a collaborative effort with the University of Maine, the Maine Tidal Power Initiative’s Site Resource Assessment (MTPI, 2012) has located specific coves and marshes that provide “NRPA Significant Wildlife Habitat for Shorebird Nesting, Feeding, and Staging Areas” as well as for “Inland Waterfowl & Wading Bird Habitat” within the Bagaduce River’s pathway. As seen in Map 4, the nearest significant habitats to the proposed Castine Harbor Dice Head Test Turbine location are some eel grass beds located in Wadsworth Cove (green patches), a large shorebird nesting, feeding and staging area in Hatch Cove

(yellow area), and two tan circles south of Dice Head that represent previously-known Bald eagle (*Haliaeetus leucocephalus*; BAEA) nest sites, circa 2012.

The Bagaduce River watershed is a key wildlife corridor for these species, as well as a provider of healthy and diverse economic resources for humans such as harboring natural nurseries for juvenile fish and shellfish, wildlife viewing, and acting as a natural storm surge buffer (BwH, 2012).



Map 4. Maine Tidal Power Initiative's Site Resource Assessment Published Habitat Map of Significant Wildlife and Essential Habitats. The red circle indicates the location of the VoltturnUS floating wind turbine.

Across the Bagaduce River and due south of Castine on the Cape Rosier peninsula lies the Holbrook Island Sanctuary. The sanctuary encompasses 1,230 acres of forests, fields, marshes, ponds, mudflats, and high-value wetland habitat. The Sanctuary is managed by the State of Maine under the Bureau of Parks and Lands, encouraging visitors to hike the trails and enjoy the abundant mammals and birds that frequent the park. A "Checklist of the

Birds” for Holbrook Island Sanctuary is available to help birders identify the timing and abundance of the avian species known to utilize this habitat (Holbrook Island Sanctuary, 2001). Out of the 223 birds listed in this checklist, 26 were observed in this survey; 10 of the observed species are also listed as “known to breed in the sanctuary.”

Although both the Bagaduce River watershed and the Holbrook Island Sanctuary are not directly in the area of the Castine Harbor Dice Head Test Turbine Site, the wildlife that use these habitats may, at some point, find contact with the turbine’s location. Due to the siting of the VoltturnUS 1/8<sup>th</sup> commercial scale floating platform near the mouth of the Bagaduce River, these hundreds of species known to use the Sanctuary and Bagaduce River’s habitats may follow the river on their way to Penobscot Bay and the pass by the test turbine’s location. For this reason, it is essential to keep in mind the ecological habitats within the vicinity of the Castine Harbor Dice Head Test Site and the avian species that are known to use its resources.

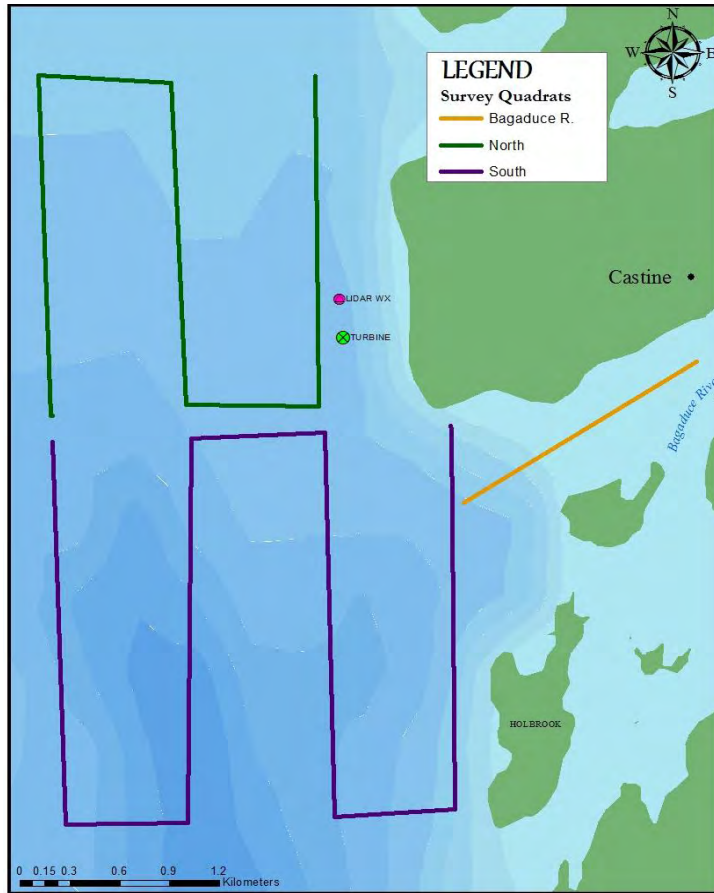
### **III. METHODS**

Visual boat-based observations were conducted at the Castine Harbor Dice Head Test Site through four weeks in September and one survey in October of 2014. The survey vessels and captains were provided by Maine Maritime Academy, also located in Castine, Maine. Exact location of the comprehensive survey area was chosen to best cover the wildlife use of the Bagaduce River’s outlet and the area near Dice Head, at the western and southern edge of Castine’s peninsula, as seen previously in Map 1. No control or test area was designated, such as in the protocol used for the Monhegan Offshore Wind Turbine test site (Kennedy & Holberton, 2012); however two quadrats were surveyed using a similar experimental design.

The “north” quadrat covers the region to the west of the Castine peninsula, which is near Dice’s Head, and the “south” quadrat is adjacent to and south of the “north” quadrat, but also covering more of the river’s outlet and due west of Nautilus Island and the northern part of Holbrook Island (Map 5). A third single transect strip includes a single one-mile strip up from the river’s mouth. This was due to abundant bird activity and their use of the Bagaduce River’s “Significant Wildlife Habitat,” as noted under Focus Areas of Statewide Ecological Significance (BwH, 2012). The exact location of the 1/8<sup>th</sup> scale VoltturnUS test turbine on a floating platform is found within an existing cable way (as seen in Map 2) that lies within the area covered by the north quadrat’s coverage zone, between the 3<sup>rd</sup> strip of the transect and the Dice Head landmass.

To prevent confusion, the distinction of “Castine Test Site” refers to the entire surveyed area, and the smaller individual quadrats that lie within this larger area will be

hereafter called the “north” or “N,” “south” or “S,” and “Bagaduce River” or “BR” sites, or quadrats. The complete Castine Test Site covers roughly six square miles (15.64 km<sup>2</sup>) with



the boat traveling a linear track totaling 13.4mi (21.5km) that includes both quadrats and the river portion. All surveys were assessed equally while using the corresponding total survey areas of the south, north, and Bagaduce River quadrats for the analysis of the species composition, location, and behaviors observed within the Castine Test Site.

Map 5. Location of the survey quadrats used in the Castine Harbor Dice Head Test Site with UMaine’s VoltturnUS 1/8<sup>th</sup> scale floating turbine and Lidar Weather Station.

The north quadrat measures 1.3mi by one mile (3.4km<sup>2</sup>), the south quadrat measures 1.6mi x 1.5mi (6.2km<sup>2</sup>), and the Bagaduce River strip measures one mile long (1.6km). Surveys were performed with the vessel running at an average speed of 8.9 knots (16.4 k/h) in a N-S direction, or from the mouth of the Bagaduce River and heading upstream. Each day’s survey began at the starting waypoint in the south quadrat’s north-east corner. All birds, mammals, and other wildlife were documented when observed out to a distance of 500 m on both sides of the boat. After arriving at the next waypoint, surveying would stop and the boat would turn 90° along an E-W line and motor to the next waypoint. Once positioned on the starting point of the second transect strip, the vessel would turn again 90° and surveying would resume, heading in the N-S direction. This pattern was repeated to create four survey strips within the south quadrat (always performed first), followed by a short gap of 0.2 miles and then performing three survey strips, as previously

described, to finish the north quadrat. Immediately following the north quadrat, surveying stopped until the vessel reached the starting point for the Bagaduce River’s transect.

All surveys were conducted upon the Maine Maritime Academy’s research vessels driven by Captain Zander Parker. The *M/V Quickwater*, a 41ft utility vessel, was used for the September 3 & 9 surveys and the final three surveys were performed aboard the *M/V Hannah II*, a 36’ utility vessel. Observations were conducted from the stern using binoculars and unaided vision. Height from which observations were made averaged 2.5 m above sea level. All data were recorded into a digital voice recorder, synchronized with time on a Garmin GPS unit that simultaneously logged the boat’s tracks and waypoints at the beginning and end of each transect line.

Codes used to document species behaviors and other observation and weather conditions followed Gould & Forsell (1989) and Tasker et al. (1984). Examples of common bird behaviors include but are not limited the behaviors provided in Table 1. See Appendix 1 for a complete list of behaviors. Other information includes flight height, estimated using the eye, and recorded in single meters when under a height of five meters or otherwise compartmentalized into five-meter "bins" (10, 15, 20, 25, etc.) up to 50 m. Observations were documented as “> 50 m” for all those above 50 m. The number of birds, species, gender and age (if known), and flight direction (see details below) were recorded. The data were transcribed into Excel and mapped with ArcMap 10.2 software.

Table 1. Example of most common codes used to document behaviors observed during transects (Gould & Forsell, 1989).

Bird Behavior
1 = Sitting on water
20 = Flying in direct and consistent heading
32 = Flying, following ship
35 = Flying, milling or circling (foraging)
48 = Flying, meandering
61 = Feeding at or near surface while flying (dipping or pattering)
65 = Feeding at or near surface, not diving or flying (surface scavenging)
70 = Feeding below surface (pursuit diving)

Some of the most common behaviors documented have lengthy definitions; therefore a shortened descriptive behavior term is used in the following sections. These include the following codes: **#20**, described as “flying in a direct and consistent heading” but hereafter shortened to “direct flight”; **#35**, described as “flying, milling or circling” which typically involves flight associated with foraging behavior and is erratic in height and location, hereafter called “milling”; **#48**, described as “flying, meandering” which involves

indirect flight that changes direction but not necessarily height, hereafter called “meandering”; #61, described as “feeding at or near the surface while flying (dipping or pattering)” which typically describes scavenging or the act of picking food from the water’s surface, hereafter called “pattering”; and #65, described as “feeding at or near surface, not diving or flying (surface scavenging)” which differs from dipping in that the bird is sitting in the water while foraging, hereafter called “scavenging.”

Four-letter species “alpha” codes may be used in the following tables to simplify table content (see Table 3 for species codes and common names and Appendix 2 also provides scientific names). Flight directions, given in cardinal direction such as NE, SW, WNW, represent the direction in which the bird was flying at the time of observation.

## IV. RESULTS

Five survey days were conducted from September to 1 October 2014. The total area covered on each survey day, which includes the 500m incorporated to each side of the transect strip, measured 8.24km<sup>2</sup> in the south quadrat, 5.8km<sup>2</sup> in the north quadrat, and 1.6km<sup>2</sup> in the Bagaduce River’s transect, for a grand total of 15.64km<sup>2</sup>.

Table 2 provides the breakdown of the surveys by time of day, sea, and weather conditions during this period of time. Only one of the five days surveyed found the turbine spinning, which is noted also in Table 2, and generally the turbine was spinning at a much reduced speed or experienced varying speeds throughout the duration of the survey period. This state of motion is noted only for the period of time in which the survey was conducted.

Table 2. Survey date, period, and weather conditions.

2014	SURVEY CONDITIONS					
DATE	TIME	Sea ht (ft)	Wind dir	Wind (kt)	Sky	Turbine
SEPTEMBER						
3	AM	1.25 to 2	WNW	10	Clear	N
9	PM	0.5 to 1.25	S	10	Partly	Y
17	AM	0.5	W to NW	3	Clear	N
23	AM	1 TO 1.5	W	10	Clear	N
OCTOBER						
1	PM	1	NE	10	Overcast	N





Table 3. All observed species with code, densities, and quadrat during September through October 1, 2014.

Common name	Total	Overall/ km2	SPP	NORTH	North/ km2	Most frequent	SOUTH	South/ km2	Most frequent	BR	BR/ km2	Most frequent
Common loon	12	0.79	COLO	8	1.379	sitting	3	0.364	direct flight	1	0.625	sitting
Red-throated loon	10	0.57	RTLO	10	1.724	direct flight						
Common eider	12	2.50	COEI							12	7.500	sitting
Black scoter	2	0.11	BLSC	2	0.345	sitting/direct flight						
Canada goose	2	0.42	CAGO							2	1.250	sitting
Red-necked grebe	1	0.06	RNGR	1	0.172	sitting						
Herring gull	294	17.97	HERG	61	10.517	sitting	203	24.636	sitting	30	18.750	direct flight
Great black-backed gull	3	0.29	GBBG				2	0.243	sitting	1	0.625	meandering
Black-legged kittiwake	2	0.08	BLKI				2	0.243	direct/milling flight			
Ring-billed gull	50	3.02	RBGU	19	3.276	scavenging	27	3.277	sitting	4	2.500	direct flight
Laughing gull	2	0.11	LAGU	2	0.345	direct flight						
Bonaparte's gull	58	6.22	BOGU	1	0.172	direct flight	34	4.126	sitting	23	14.375	pattering
Common tern	11	0.95	COTE				8	0.971	milling	3	1.875	pattering
Black guillemot	44	6.67	BLGU	1	0.172	sitting	14	1.699	sitting	29	18.125	sitting
Shorebird	12	0.49	SHORE				12	1.456	meandering			
Northern gannet	1	0.04	NOGA				1	0.121	sitting			
Great cormorant	1	0.172	GRCO	1	0.172	direct flight	1	0.121	direct flight			
Double-crested cormorant	27	4.97	DCCO	1	0.172	sitting	3	0.364	direct flight	23	14.375	sitting on rock
American crow	9	1.04	AMCR				5	0.607	direct flight	4	2.500	direct flight
Barn swallow	2	0.08	BASW				2	0.243	direct flight			
Hummingbird	2	0.11	HUMM	2	0.345	direct flight						
Bald eagle	1	0.04	BAEA				1	0.121	direct flight			
Bird total	559		Bird Total	109			318			132		
			per km2		3.24019			4.683523			51.5625	
Harbor seal	12		HSEAL	6	1.034	n/a	5	0.607	n/a	1	0.625	n/a
Harbor porpoise	10		HAPO	2	0.345	n/a	7	0.850	n/a	1	0.625	n/a
MM total	22		MM Total	8			12			2		
			per km2		0.237812			0.176737			0.78125	

Table 3 provides all species densities and in which quadrat, with the four-letter species code and common names for reference and also providing most frequent behavior of that species. For a more detailed table, Appendix 2 provides abundances and dates on which each species were recorded, including scientific names. Among the 22 bird species identified, which included 559 individual birds counted, only one definite State-Listed (MESA) species was observed that included a total of two great cormorants (*Phalacrocorax carbo*; GRCO), listed as State Threatened. However, a single flock of 12 birds were observed that were unable to be specifically identified to the species, but may have included a type shorebird that may have fallen into the category of potentially Federal (FT or FT\*) or State Threatened (StTh or StTh\*), or other federal and state-designated conservation status species (BCC or SSC), as seen in Table 4. These will be discussed later in Part V Section D: *Endangered, Threatened, and Birds of Conservation Status*, below. Species that are, or potentially are, FT or StTh will be marked by red text in the following tables. Also, to simplify terminology, these species will be hereafter lumped into “Species of Conservation Concern,” or SCC, and shall include the identified species as well as the potential SCC species.

Twelve harbor seals (*Phoca vitulina*) and 10 harbor porpoise (*Phocoena phocoena*) were also noted during these surveys, none of which are species of concern.

Table 4. Species of special conservation designation, including potential species.

STATUS	SPECIES
BCC	red-throated loon
SSC	laughing gull
SSC	Bonaparte’s gull
SSC	common tern
F*, FT*, StTh*, BCC*, SSC*	unidentified shorebird
StTh	great cormorant
SSC	barn swallow
BCC, SSC	bald eagle

\* indicates potential SCC

The following sections will begin with Part V- Section A, presenting a survey by survey discussion, with tables and maps to outline species, numbers, and locations. Sections B through E will discuss bird behaviors, species of concern, and all other observations. Again, Appendix 2 provides a more detailed table of this data gathered per survey day. Throughout this report, four-letter species “alpha” codes are also used to simplify text and table content.

To further discuss the bird observations during these surveys, bird species will be generally grouped by a taxonomical classification at the Order level. Seven orders within the Class Aves were observed utilizing this region within the Gulf of Maine during the

course of our study. The maps and figures used in this report have been colored using a consistent scheme that groups each of these five Groups by color. Group 1 (eider, scoters, ducks, grebes, geese, and loons) is represented by shades of green (hereafter called “Group 1A”), Group 2 (gulls and terns) have yellows (“Group 2C”), Group 3 (cormorants and gannet) is red (“Group 3S”), Group 4 (crows and songbirds) is blue (“Group 4P”), and Group 5 (eagle) is brown (“Group 5A”). This color scheme will continue to be used when discussing bird behaviors, foraging species, and birds of conservation concern, as seen below. It does not include marine mammals or other species.

The five Species-Groups are as follows:

<b>-Order Anseriformes</b>	(eider, scoters, geese, and ducks)	<b>GROUP 1</b>
<b>-Order Gaviiformes</b>	(loons)	
<b>-Order Podicepsiformes</b>	(grebes)	
<b>-Order Charadriiformes</b>	(large and small gulls, terns)	<b>GROUP 2</b>
<b>-Order Suliformes</b>	(cormorants and gannet)	<b>GROUP 3</b>
<b>-Order Passeriformes</b>	(corvids and songbirds)	<b>GROUP 4</b>
<b>-Order Accipiteriformes</b>	(eagle)	<b>GROUP 5</b>

## A. Surveys by Day

**SEPTEMBER 3, 2014**

**MORNING SURVEY (9:26 am)**

Table 5. Numbers of species observed Sept 3.

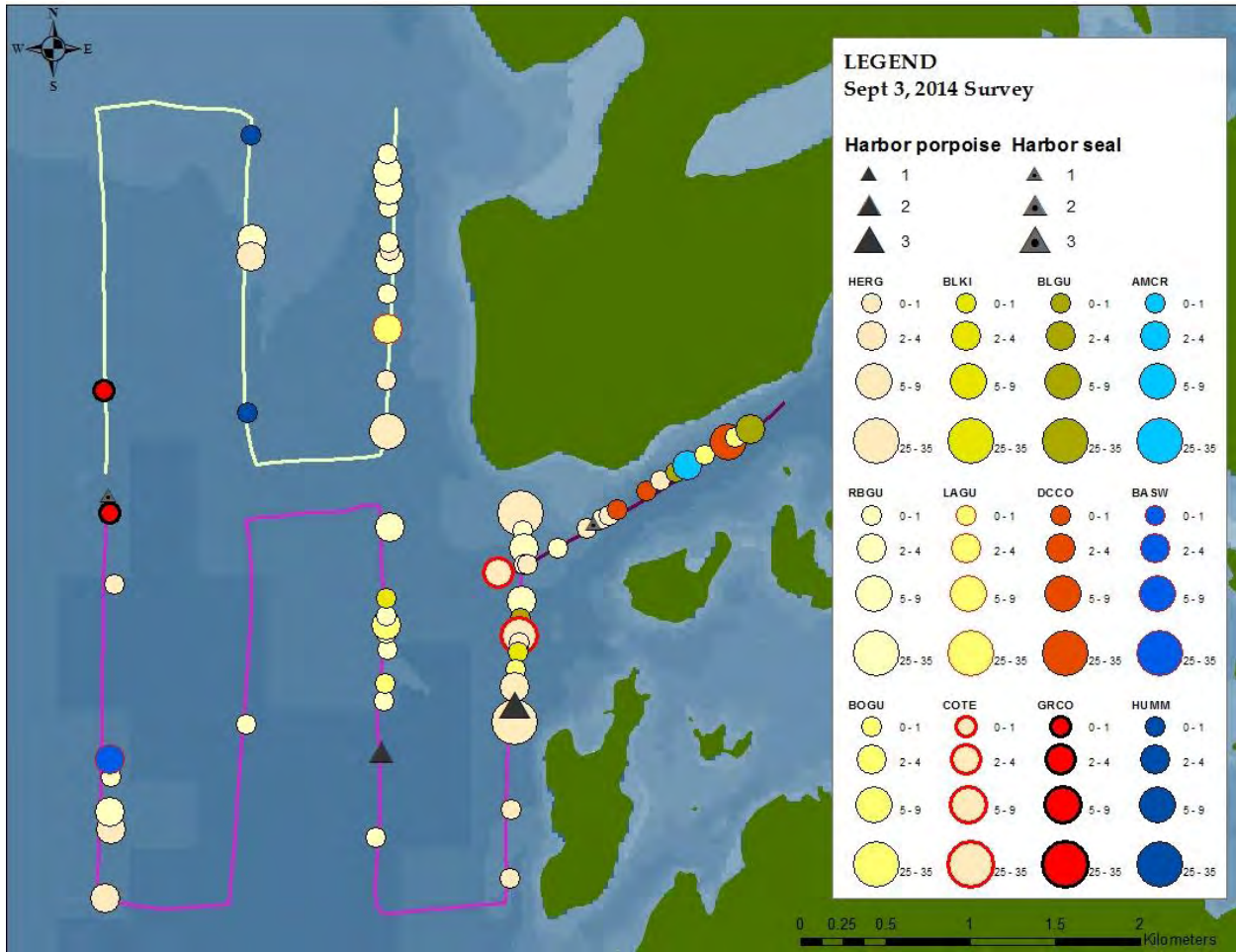
SPECIES	N	S	BR	Total
herring gull	9	74	5	88
black-legged kittiwake		2		2
ring-billed gull	17	19	1	37
laughing gull	2			2
Bonaparte's gull		6	2	8
common tern		8	3	11
black guillemot		1	5	6
great cormorant	1	1		2
double-crested cormorant			11	11
American crow			2	2
barn swallow		2		2
hummingbird	2			2
harbor seal		1	1	2
harbor porpoise		5		5
<b>Bird Total</b>	<b>31</b>	<b>113</b>	<b>29</b>	<b>173</b>
<b>Birds/km<sup>2</sup></b>	<b>5.3</b>	<b>13.7</b>	<b>18.1</b>	<b>12.4</b>

Table 6. Bird species, behavior code, and flight height on Sept 3.

BEHAVIOR	1	10	20						35			48	61	65		Total
HEIGHT (m)	0	0	1	2	3	5	10	15	2	3	5	20	2	0	1	
HERG	36			1	2	2		1	35	4		1			6	88
BLKI					1						1					2
RBGU	14		2			1	1							16	3	37
LAGU				2												2
BOGU	7										1					8
COTE										8			3			11
BLGU	6															6
GRCO			1	1												2
DCCO		9	1					1								11
AMCR			2													2
BASW					2											2
HUMM			1	1												2
<b>Grand Total</b>	<b>63</b>	<b>9</b>	<b>7</b>	<b>4</b>	<b>6</b>	<b>3</b>	<b>1</b>	<b>2</b>	<b>35</b>	<b>12</b>	<b>2</b>	<b>1</b>	<b>3</b>	<b>22</b>	<b>3</b>	<b>173</b>

On September 3<sup>rd</sup>, conditions were rated as “Maximum” with seas ranging from 1.25 to two feet (0.38-0.6 m), with winds from the WNW at 10 knots and clear sky. The VoltturnUS turbine was not spinning at the time of the survey. [Map 6](#) shows the general survey tracklines with the location and number of animals recorded. Of the 12 total bird species observed on this date, 65% were found in the south quadrat and included eight species, followed by 18% found in the north, and only 17% in the BR. The top four species on this day were herring gulls (*L. argentatus*; HERG; 51%), followed by ring-billed gull (*L. delawarensis*; RBGU) at 21%, and both common tern (*Sterna hirundo*; COTE) and double-crested cormorant (*P. auritus*; DCCO) were tied for third most common at six percent ([Table 5](#)). Two harbor seals and five harbor porpoise were observed.

Table 6 shows all behaviors by all bird species observed. Thirty-six percent of all birds were observed sitting in the water followed by 28% of birds milling. Of all birds, 45% demonstrated a foraging behavior.



Map 6. Observations of wildlife during September 3 survey.

# SEPTEMBER 9, 2014

# AFTERNOON SURVEY (14:06 pm)

Table 7. Numbers of species observed Sept 9.

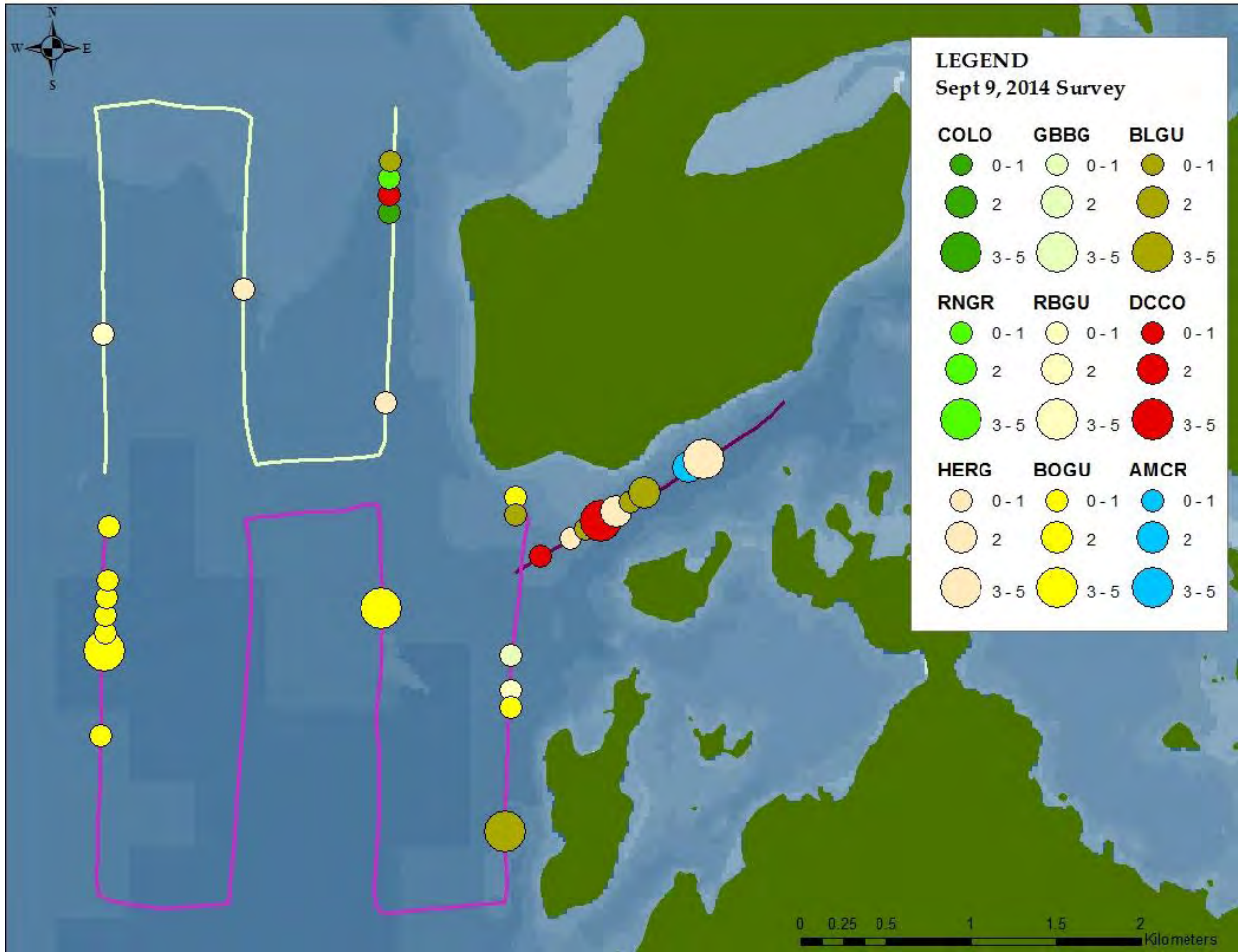
SPP	N	S	BR	Total
COLO	1			1
RNGR	1			1
HERG	2		8	10
GBBG		1		1
RBGU	1	1		2
BOGU		15		15
BLGU	1	6	4	11
DCCO	1		4	5
AMCR			2	2
<b>Bird Total</b>	<b>7</b>	<b>23</b>	<b>18</b>	<b>48</b>
<b>Birds/km<sup>2</sup></b>	<b>1.2</b>	<b>2.8</b>	<b>11.3</b>	<b>5.1</b>

Table 8. Bird species, behavior code, and flight height on Sept 9.

BEHAVIOR	1	10	20					65	
HEIGHT (m)	0	1	1	2	5	10	20	0	Total
COLO	1								1
RNGR	1								1
HERG	1		1		2	3	3		10
GBBG	1								1
RBGU	1				1				2
BOGU	11				3			1	15
BLGU	11								11
DCCO	2	3							5
AMCR				2					2
<b>Grand Total</b>	<b>29</b>	<b>3</b>	<b>1</b>	<b>2</b>	<b>6</b>	<b>3</b>	<b>3</b>	<b>1</b>	<b>48</b>

On September 9<sup>th</sup>, conditions were rated as “Maximum” with seas ranging from 0.25 – 1.25 feet (0.08 - 0.38m), with winds from the south at 10 knots and partly cloudy sky. The VolturnUS turbine was spinning at the time of the survey. [Map 7](#) shows the general survey tracklines with the location and number of animals recorded. Of the nine total bird species observed on this date, 48% were found in the south quadrat and included four species, followed by 38% found in the BR, and only 15% in the north. The top three species on this day were Bonaparte’s gulls (*Chroicocephalus philadelphia*; BOGU) (31%), followed by black guillemot (*Cepphus grille*; BLGU) at 23%, and HERG at 21% ([Table 7](#)). No marine mammals were observed.

[Table 8](#) shows all behaviors by all bird species observed. Sixty percent of all birds were observed sitting in the water followed by 31% of birds flying direct. Of all birds, only one BOGU demonstrated a foraging behavior.



Map 7. Observations of wildlife during September 9 survey.



# SEPTEMBER 17, 2014

# MORNING SURVEY (8:32 am)

Table 9. Numbers of species observed Sept 17.

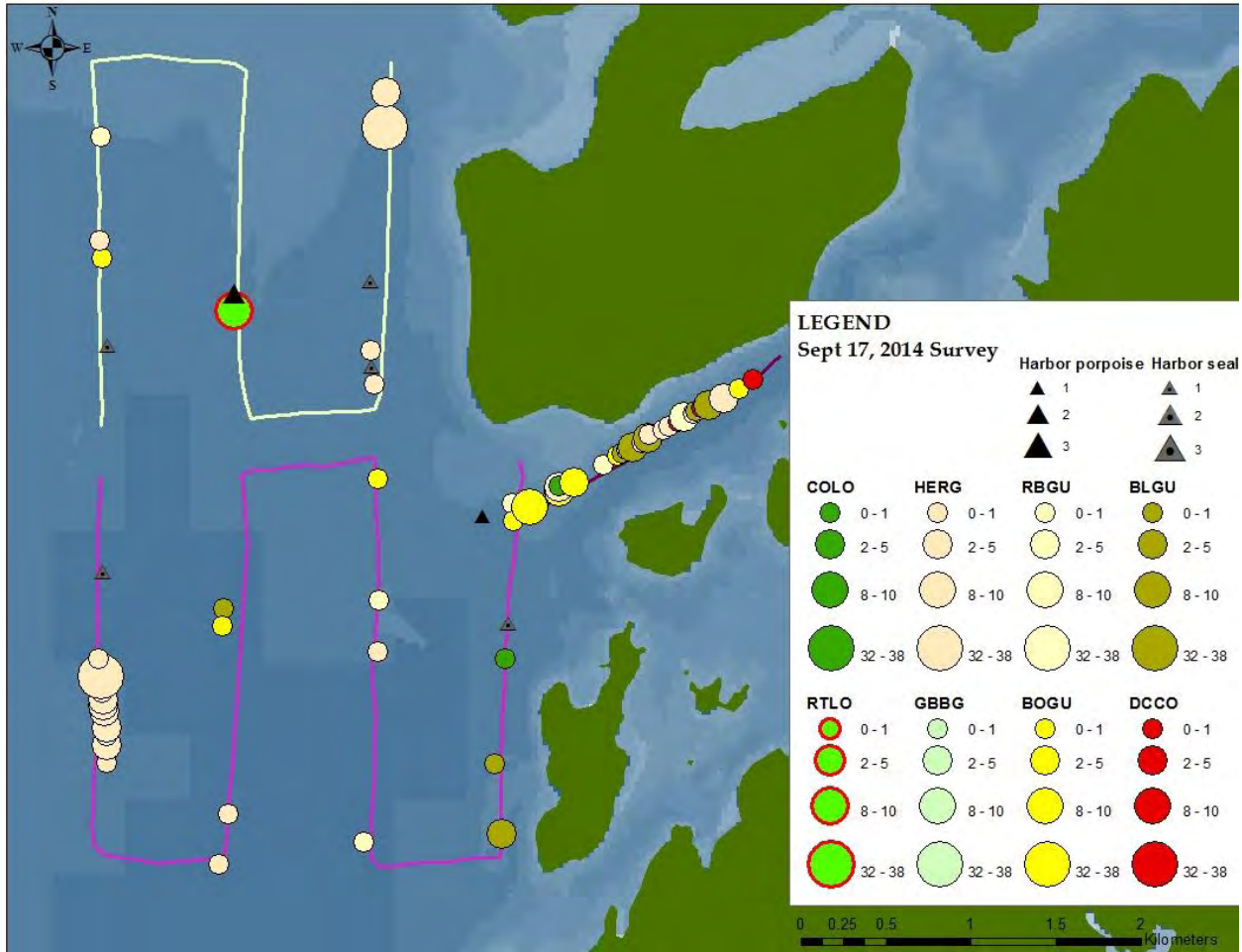
SPP	N	S	BR	Total
COLO		1	1	2
RTLO	10			10
HERG	44	53	12	109
GBBG		1		1
RBGU	1	3	3	7
BOGU	1	3	14	18
BLGU		4	9	13
DCCO			4	4
HSEAL	3	2		5
HAPO	2		1	3
<b>Bird Total</b>	<b>61</b>	<b>67</b>	<b>44</b>	<b>172</b>
<b>Birds/km<sup>2</sup></b>	<b>10.5</b>	<b>8.1</b>	<b>27.5</b>	<b>15.4</b>

Table 10. Bird species, behavior code, and flight height on Sept 17.

BEHAVIOR	1	20						35		61	65	70	
HEIGHT (m)	0	1	2	3	5	10	15	2	5	5	5	0	Total
COLO	1			1									2
RTLO							10						10
HERG	92	9		2	1	4		1					109
GBBG	1												1
RBGU					4	2					1		7
BOGU	2		1			1		1	2	10		1	18
BLGU	12	1											13
DCCO	2	2											4
<b>Total</b>	<b>110</b>	<b>12</b>	<b>1</b>	<b>3</b>	<b>5</b>	<b>7</b>	<b>10</b>	<b>1</b>	<b>3</b>	<b>10</b>	<b>1</b>	<b>1</b>	<b>164</b>

On September 17<sup>th</sup>, conditions were rated as “Maximum” with seas at 0.5 feet (0.16m) and winds from the west at three knots with a clear sky. The VoltturnUS turbine was not spinning at the time of the survey. Map 8 shows the general survey tracklines with the location and number of animals recorded. Of the eight total bird species observed on this date, 39% were found in the south quadrat and included six species, followed by 35% found in the north, and only 26% in the BR. The top three species on this day were HERG (63%), followed by BOGU at 10%, and BLGU at 8% (Table 9). Five harbor seals and three harbor porpoise were observed.

Table 10 shows all behaviors by all bird species observed. Sixty-seven percent of all birds were observed sitting in the water followed by 38% of birds flying direct. Of all birds, only one BOGU demonstrated a foraging behavior.



Map 8. Observations of wildlife during September 17 survey.

# SEPTEMBER 23, 2014

# MORNING SURVEY (8:26 am)

Table 11. Numbers of species observed Sept 23.

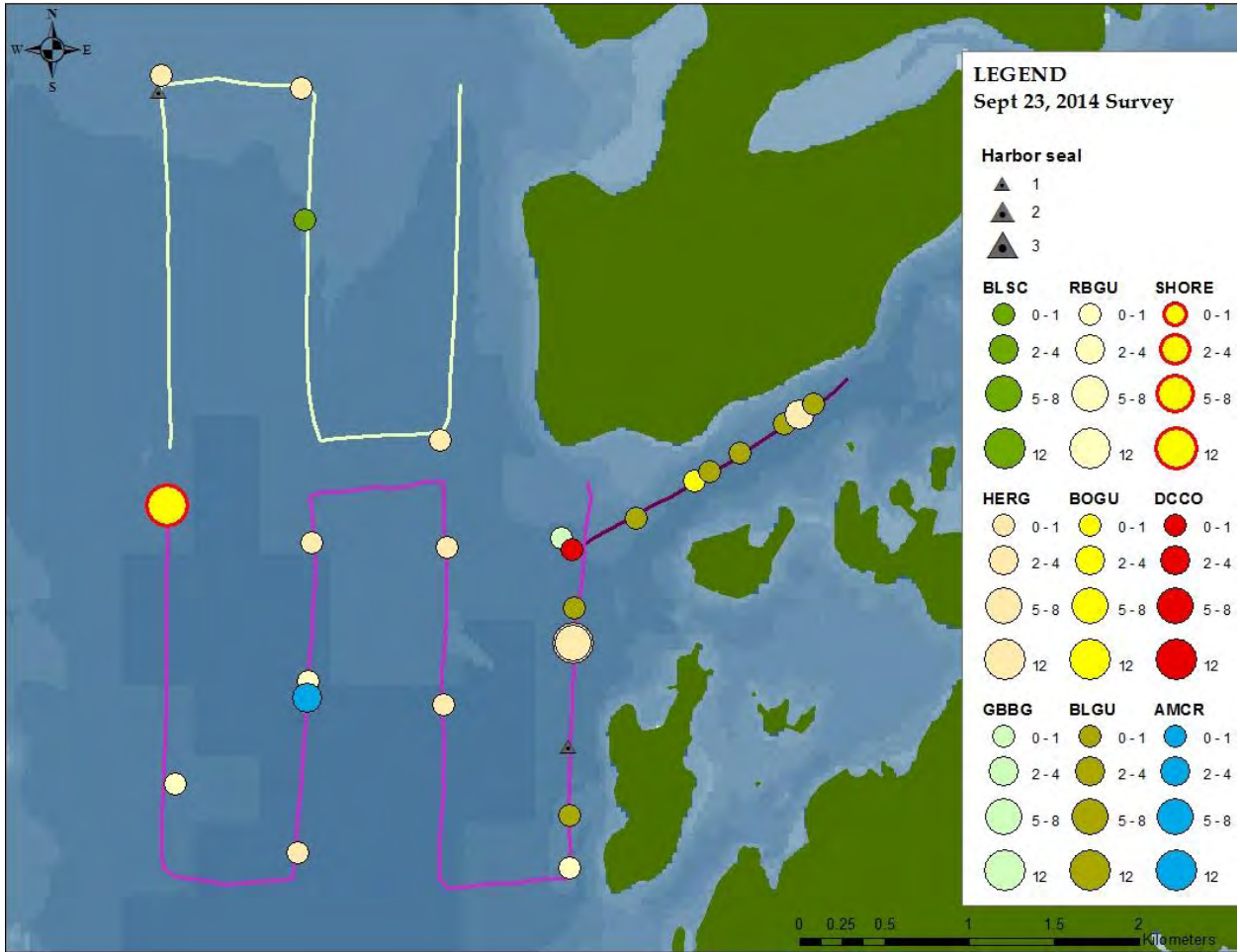
SPP	N	S	BR	Total
BLSC	1			1
HERG	3	31	2	36
GBBG			1	1
RBGU		3		3
BOGU			1	1
BLGU		2	5	7
SHORE		12		12
DCCO			1	1
AMCR		4		4
HSEAL	1	1		2
<b>Bird Total</b>	<b>4</b>	<b>52</b>	<b>10</b>	<b>66</b>
<b>Birds/km<sup>2</sup></b>	<b>0.7</b>	<b>6.3</b>	<b>6.3</b>	<b>4.4</b>

Table 12. Bird species, behavior code, and flight height on Sept 23.

BEHAVIOR	1	20				32		35	48				61		65	Total
HEIGHT (m)	0	1	5	10	20	5	10	5	5	10	15	20	2	5	0	Total
BLSC		1														1
HERG	2		2			1	1	8		1			1	8	12	36
GBBG									1							1
RBGU				1						1	1					3
BOGU															1	1
BLGU	7															7
SHORE												12				12
DCCO		1														1
AMCR					4											4
HSEAL	2															2
<b>Total</b>	<b>11</b>	<b>2</b>	<b>2</b>	<b>1</b>	<b>4</b>	<b>1</b>	<b>1</b>	<b>8</b>	<b>1</b>	<b>2</b>	<b>1</b>	<b>12</b>	<b>1</b>	<b>8</b>	<b>13</b>	<b>68</b>

On September 23<sup>rd</sup>, conditions were rated as “Maximum” with seas ranging from one to 1.5 feet (0.3 – 0.45m), with winds from the west at 10 knots and clear sky. The VoltturnUS turbine was not spinning at the time of the survey. [Map 9](#) shows the general survey tracklines with the location and number of animals recorded. Of the nine total bird species observed on this date, 79% were found in the south quadrat and included six species, followed by 15% found in the BR, and only 6% in the north. The top three species on this day were HERG (55%), followed by a single flock of 12 unidentified shorebirds (18%), and BLGU at 11% ([Table 11](#)). Only two harbor seals were observed.

[Table 12](#) shows all behaviors by all bird species observed. Twenty-four percent of all birds were observed meandering followed by 19% of birds foraging while sitting, and then 16% of all birds sat in the water. Of all birds, 44% demonstrated a foraging behavior.



Map 9. Observations of wildlife during September 23 survey.

OCTOBER 1, 2014

AFTERNOON SURVEY (14:48 pm)

Table 13. Numbers of species observed Oct 1.

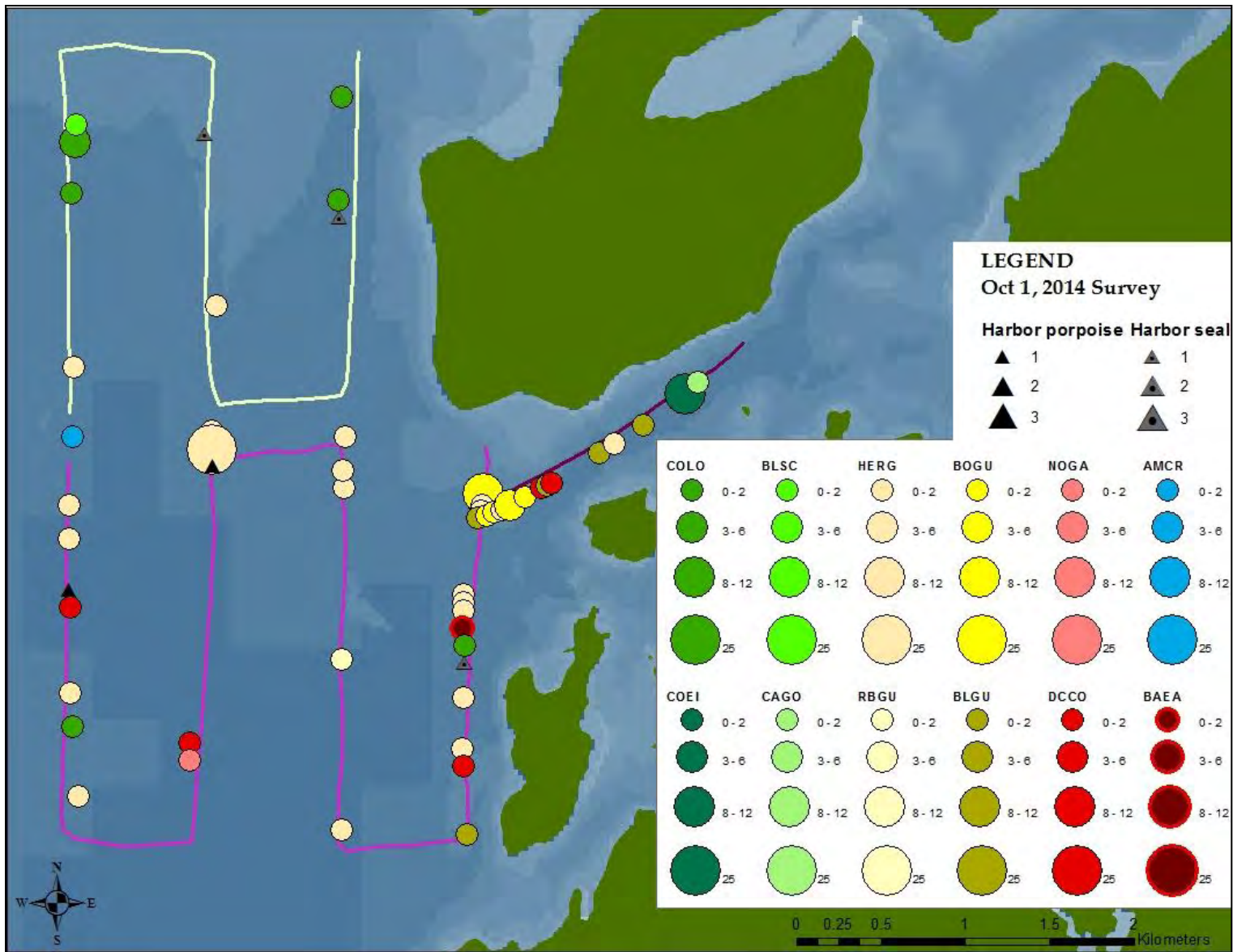
SPP	N	S	BR	Total
COLO	7	2		9
COEI			12	12
BLSC	1			1
CAGO			2	2
HERG	3	45	3	51
RBGU		1		1
BOGU		10	6	16
BLGU		1	6	7
NOGA		1		1
DCCO		3	3	6
AMCR		1		1
BAEA		1		1
HSEAL	2	1		3
HAPO		2		2
<b>Bird Total</b>	<b>11</b>	<b>65</b>	<b>32</b>	<b>108</b>
<b>Birds/km<sup>2</sup></b>	<b>1.9</b>	<b>7.9</b>	<b>20</b>	<b>9.9</b>

Table 14. Bird species, behavior code, and flight height on Oct 1.

BEHAVIOR	1	20						32	35					48		61			70	Total	
HEIGHT (m)	0	1	3	5	10	15	25	1	1	3	5	15	25	5	10	1	5	10	0	Total	
COLO	6			2			1													9	
COEI	12																			12	
BLSC	1																			1	
CAGO	2																			2	
HERG	26		2	3	5	4	1	2	2			1	1	1	1		1	1		51	
RBGU					1															1	
BOGU	4									1	1						10			16	
BLGU	5																		2	7	
NOGA	1																			1	
DCCO	3	2					1													6	
AMCR							1													1	
BAEA					1															1	
<b>Total</b>	<b>60</b>	<b>2</b>	<b>2</b>	<b>5</b>	<b>7</b>	<b>7</b>	<b>1</b>	<b>2</b>	<b>2</b>	<b>1</b>	<b>1</b>	<b>1</b>	<b>1</b>	<b>1</b>	<b>1</b>	<b>1</b>	<b>10</b>	<b>1</b>	<b>1</b>	<b>2</b>	<b>108</b>

On October 1<sup>st</sup>, conditions were rated as “Maximum” with seas at one foot (0.3m), with winds from the NE at 10 knots and an overcast sky. The VoltturnUS turbine was not spinning at the time of the survey. Map 10 shows the general survey tracklines with the location and number of animals recorded. Of the 12 total bird species observed on this date, 60% were found in the south quadrat and included nine species, followed by 30% found in the BR, and only 10% in the north. The top three species on this day were HERG (47%), followed by a BOGU at 15%, and common eider (*Somateria mollissima*; COEI) at 11% (Table 13). Three harbor seals and two harbor porpoise were observed.

Table 14 shows all behaviors by all bird species observed. Fifty-six percent of all birds were observed sitting on the water followed by 22% of birds flying direct. Of all birds, 19% demonstrated a foraging behavior.



Map 10. Observations of wildlife during October 1 survey.

## B. *Bird Species Abundance and Diversity, September – October 2014*

Of the five days, the greatest abundance of wildlife was observed on September 17<sup>th</sup> with 15.4/km<sup>2</sup> (Map 8), and the least abundance was on September 23<sup>rd</sup> with 4.4/km<sup>2</sup> (Map 9). Map 11a shows the overall distribution of all bird species as a whole, and Map 11b shows all abundances by date for the five surveys. All wildlife species observed within the Castine Test Site are presented in Tables 15 a, b, c, & d, in order of greatest density to least, according to quadrat. Herring gulls were the most common birds, found as the top species across the three separate quadrats as well as overall. Of the separate transects, the south quadrat had the greatest diversity of species, with 15 identified species of birds, whereas the north quadrat had 12 species of birds, and the BR had 14 bird species recorded. Both the harbor porpoise and harbor seal were recorded in all quadrats with the greatest abundance of harbor seals found in the north quadrat and the greatest abundance of harbor porpoise were found in the south (Table 3).

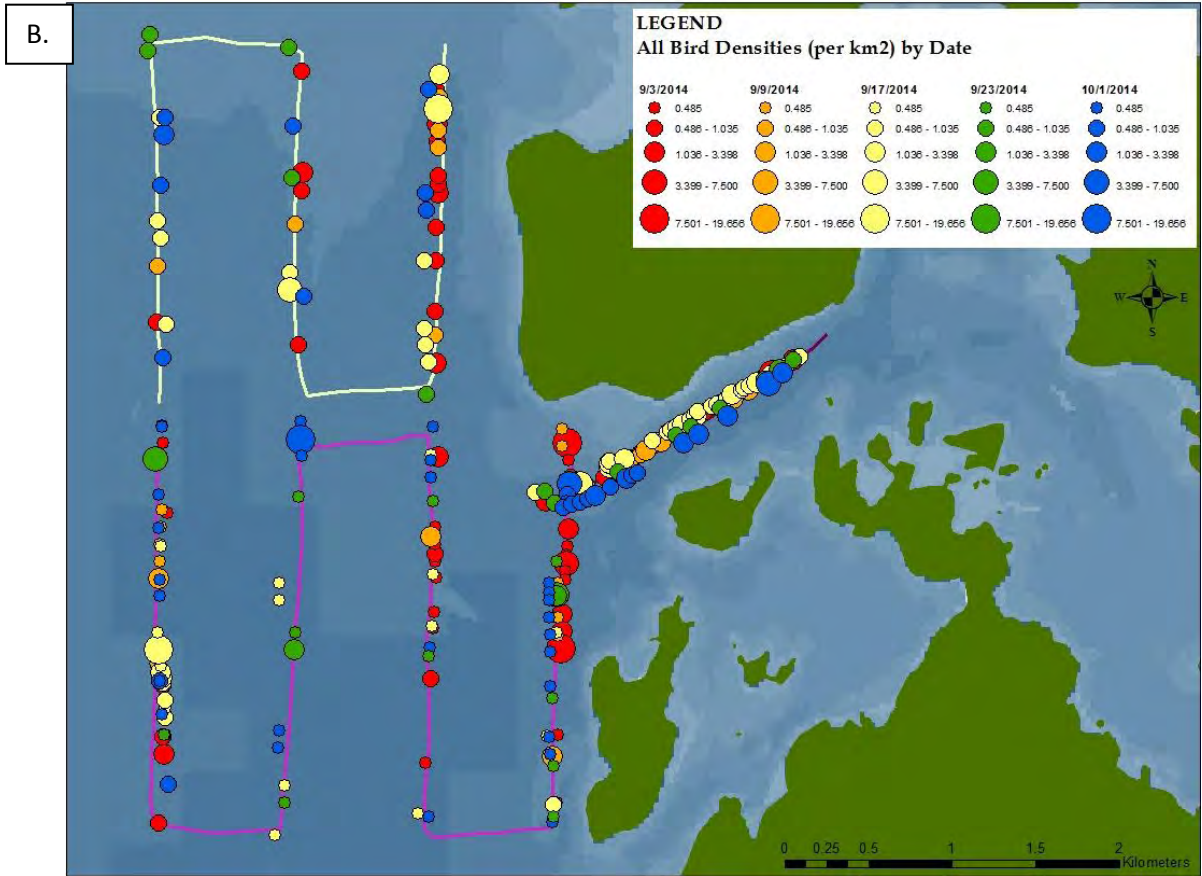
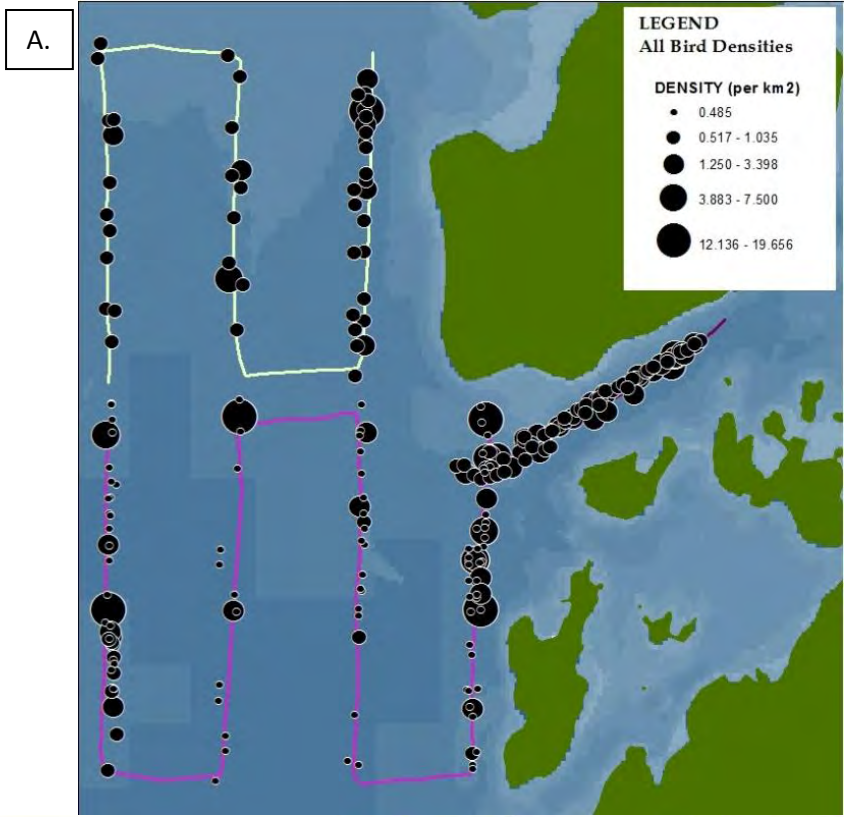
Tables 15a, b, c, & d: Species, numbers and wildlife from most abundant to least. (a) Species abundance and densities for the overall total Castine Test Site; (b) the north quadrat; (c) south; (d) and Bagaduce River.

SPP	Total	Density
HERG	294	17.968
BLGU	44	6.665
BOGU	58	6.225
DCCO	27	4.970
RBGU	50	3.018
COEI	12	2.500
AMCR	9	1.036
COTE	11	0.949
COLO	12	0.789
RTLO	10	0.575
SHORE	12	0.485
CAGO	2	0.417
GBBG	3	0.289
BLSC	2	0.115
LAGU	2	0.115
HUMM	2	0.115
GRCO	2	0.098
BLKI	2	0.081
BASW	2	0.081
RNGR	1	0.057
NOGA	1	0.040
BAEA	1	0.040

SPP	NORTH	North/km2
HERG	61	10.517
RBGU	19	3.276
RTLO	10	1.724
COLO	8	1.379
BLSC	2	0.345
LAGU	2	0.345
HUMM	2	0.345
RNGR	1	0.172
BOGU	1	0.172
BLGU	1	0.172
GRCO	1	0.172
DCCO	1	0.172

SPP	SOUTH	South/km2
HERG	203	24.636
BOGU	34	4.126
RBGU	27	3.277
BLGU	14	1.699
SHORE	12	1.456
COTE	8	0.971
AMCR	5	0.607
COLO	3	0.364
DCCO	3	0.364
GBBG	2	0.243
BLKI	2	0.243
BASW	2	0.243
NOGA	1	0.121
GRCO	1	0.121
BAEA	1	0.121

SPP	BR	BR/km2
HERG	30	18.750
BLGU	29	18.125
BOGU	23	14.375
DCCO	23	14.375
COEI	12	7.500
RBGU	4	2.500
AMCR	4	2.500
COTE	3	1.875
CAGO	2	1.250
COLO	1	0.625
GBBG	1	0.625



Maps 11 a & b. Distribution of bird abundance a.) by total, and b.) by five surveys throughout September to October 2014.



## **C. Bird Behavior Categories**

Table 16 has the total numbers of all birds recorded in each quadrat, tallied by behavior. Sitting on the water was the most common behavior type recorded during the surveys throughout the entire Castine Test. Direct flight was the second most common activity.

Table 16. Abundance of each bird behavior type, by quadrat.

Quadrat	Behavior Code									Total
	1	10	20	32	35	48	61	65	70	
North	63		27				1	18		109
South	150		48	4	59	17	20	20		318
Bagaduce River	58	12	34		8	2	13	2	3	132
<b>Grand Total</b>	<b>271</b>	<b>12</b>	<b>109</b>	<b>4</b>	<b>67</b>	<b>19</b>	<b>34</b>	<b>40</b>	<b>3</b>	<b>559</b>

### **1. SITTING ON THE WATER (Code #1)**

Throughout the surveys, 48% of all the recorded birds in the Castine Test Site were observed sitting on the water, which is a behavior category not meant to suggest or exclude feeding activity. This was the most common behavior observed overall, as seen in Table 16. Behaviors described as ‘sitting’ may include sleeping, preening, or resting. In the north quadrat HERG and common loons (*Gavia immer*; COLO) were the top two species observed sitting (greatest to lesser); HERG, BOGU, and tied for third RBGU and BLGU were the top birds in the south; and BLGU and COEI were the top two in the BR. The largest flocks of sitting birds recorded during this survey season involved two single flocks that included 38 HERG in the north quadrat and 32 HERG in the south quadrat, both during the morning of September 17<sup>th</sup> and both situations were associated with a working lobster boat. Of the five bird Order-Groupings, Group 2: Charadriiformes (2C) represented 88% of the birds sitting on the water, followed by Group 1: Anseriformes (1A) at only 9%.

### **2. FLYING BEHAVIORS**

Flight height and behavior were recorded in the three quadrats, and the following figures will show flight heights for the three most common flight behavior categories, separated into the north, south, and BR quadrats: Direct Flight, Milling, and Meandering.

#### **❖ a. Direct Flight (Code #20)**

Direct flight is described as a bird flying consistently through the area, not actively involved in foraging or other activities. The designation of this behavior during the survey is taken at the precise moment it is noticed by the surveyor.

Of all bird behaviors, direct flight was the second most common behavior observed throughout the entire Castine Test Site (19%) (Table 16). In the north quadrat, red-throated loon (*G. stellata*; RTLO) and HERG were the top two species demonstrating direct flight, whereas HERG and RBGU were the top two in the south, and HERG and DCCO were the top two species in the BR. A single flock of 10 RTLO flew at 15m, consisting of 37% of all birds flying direct in the north quadrat and 10 more birds flew direct at or below three meters, also comprising 37% of birds in the north. In the south quadrat, 48% of birds flew from five to 10m and consisted of 46% Charadriiformes (Group 2C) at that height, yet the entire south quadrat birds consisted of 73% Group 2C. The BR revealed 41% of birds flew at or below one meter in the BR quadrat, with the entire BR birds consisting of 71% Group 2C in direct flight (Figure 1).

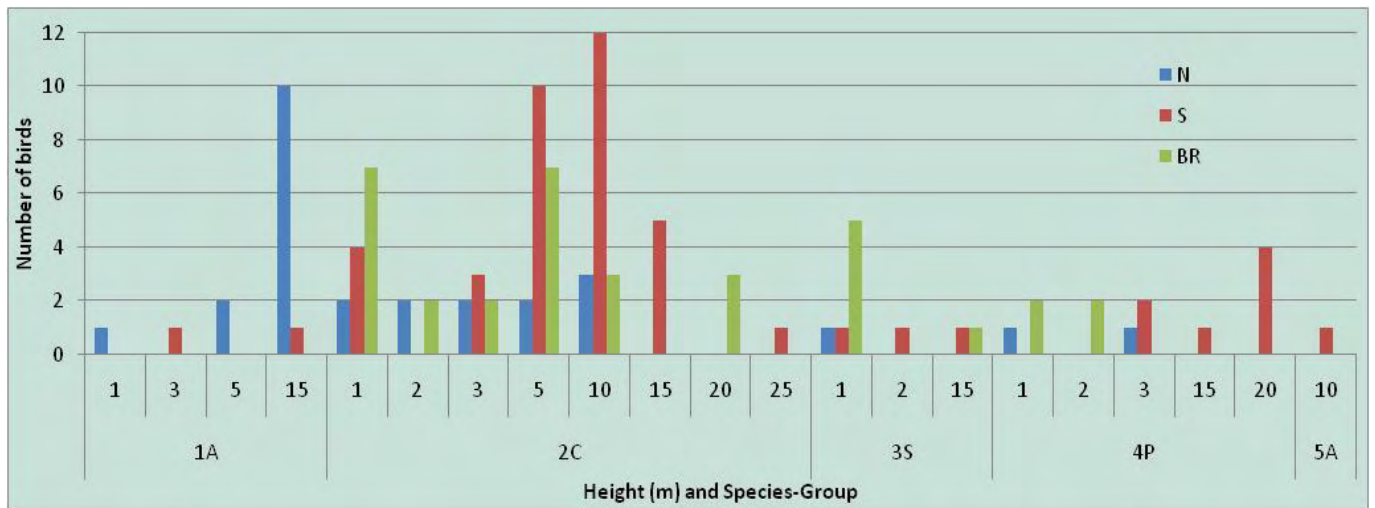


Figure 1. Numbers of bird species by Order-Group, flight height, and quadrat in Direct Flight.

### ❖ **b. Milling Flight (Code #35)**

Milling flight is described as a bird flying in a more distinct circling or milling path that is usually associated with foraging search patterns. Similar to meandering flight, general direction of milling flight constantly changes, thus flight direction is rarely noted in the survey data for these birds.

Of all bird behaviors, milling flight was the third most common behavior overall, as seen previously in Table 16. All milling birds consisted entirely of Group 2C yet no birds were ever milling in the north quadrat. In the south quadrat HERG were the top species demonstrating milling flight consisting of 83% and overall HERG comprised 78% of all milling birds throughout the Castine Test Site. Throughout all quadrats, 54% of all milling occurred at two meters (Figure 2).

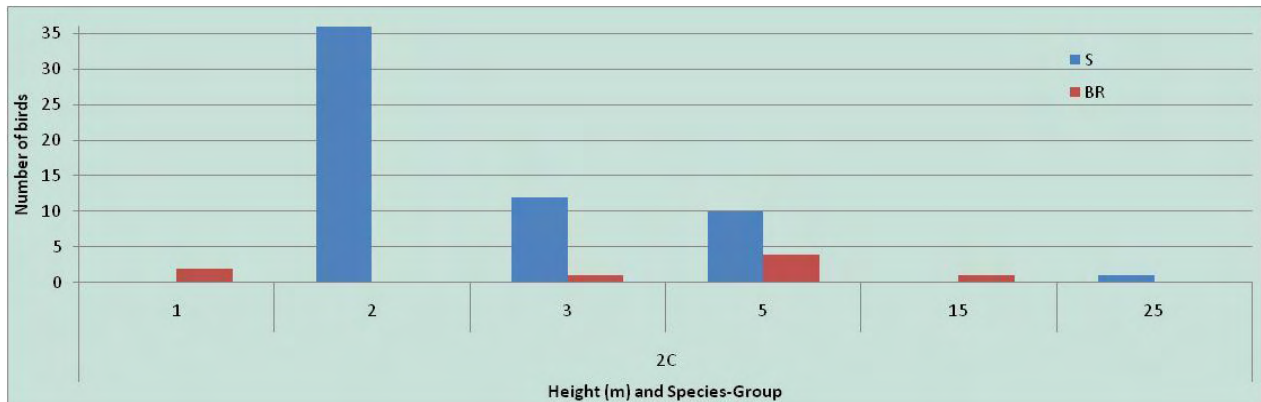


Figure 2. Numbers of bird species by Order-Group, flight height, and quadrat in Milling Flight.

### ❖ c. Meandering Flight (Code #48)

Meandering flight is defined as a bird flying in a ‘wandering’ manner, not directly feeding or moving in any particular direction or with any obvious purpose. Flight direction constantly changes, thus flight direction is rarely noted in the survey data for these birds. The designation of this behavior during the survey is taken at the precise moment it is noticed by the surveyor.

Meandering flight was the sixth most common behavior overall, as seen in Table 16. All milling birds consisted entirely of Group 2C yet no birds were ever milling in the north quadrat. In the south quadrat a single flock of 12 unidentified larger shorebirds at 20m were the top species demonstrating meandering flight and comprising 63% of all meandering birds. Only two gulls were meandering in the BR.

## 3. FORAGING AND ALL OTHER BEHAVIORS

The previous discussion focused on many behaviors that most likely are not associated with, or due to the brief period of the observed moment, cannot be determined as, foraging activities. Other behaviors are, however, evident activities that involve effort to forage for food either at the surface or below the water. Milling flight (#35) is a foraging behavior; it has been discussed in the previous section regarding flight behaviors but will be incorporated again in this section and combined with pattering (#61), scavenging while sitting (#65), and pursuit diving (#70).

For behavioral category comparisons, we will focus on the combination of the above-mentioned foraging behaviors in this following discussion. Figure 3 shows the locations of these foraging activities which involved 17% of all bird behaviors in the north quadrat, 31% in the south, and 20% in the BR (Map 12). Overall, 69% of all foraging

behaviors occurred in the south quadrat followed by 18% in the BR, and all birds included only Group 2C.

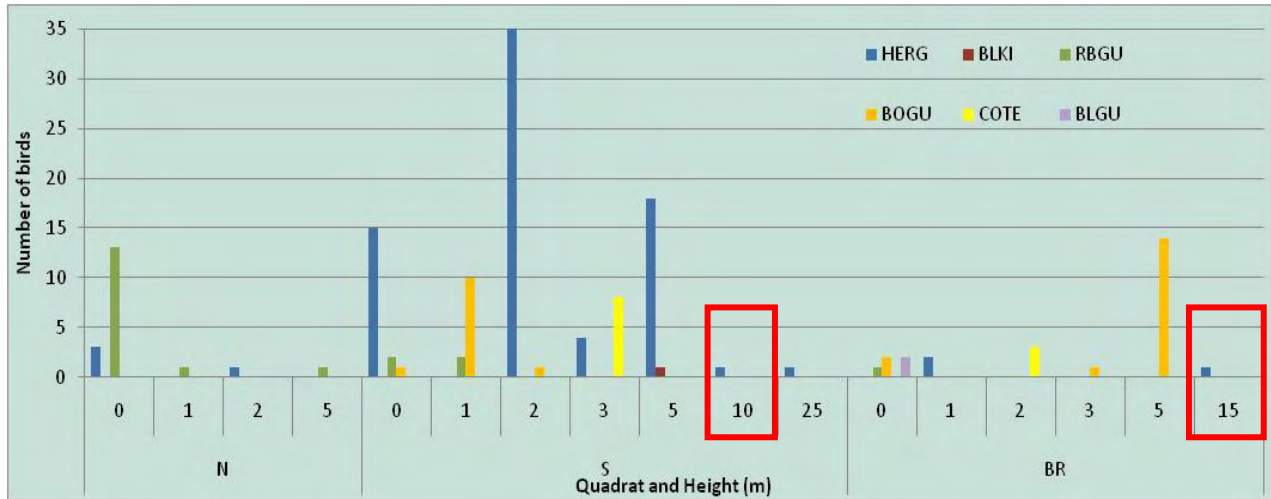
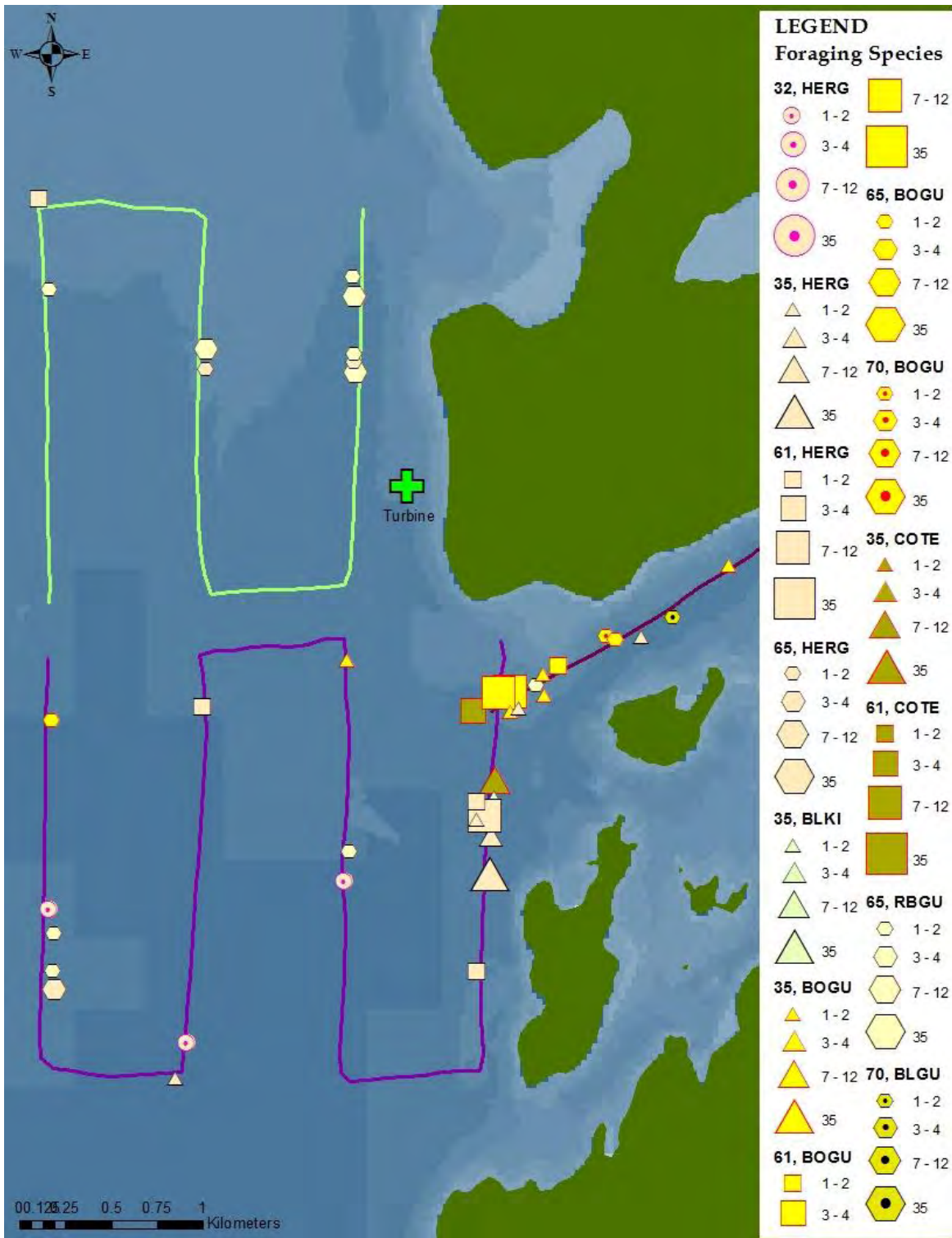


Figure 3. Numbers of each foraging species by flight height and quadrat.

Among these foraging species, 56% of the foraging birds were HERG followed by 20% BOGU. Of these foragers, the most frequented height involved 28% flying at two meters and 27% were sitting on the water. Only one HERG foraged within the RSZ (between 10-20m) in the south quadrat and only one HERG foraged in the BR.

Foraging activities often coincide with the presence of humans, and are commonly associated with the lobster and fishing industry that is prevalent in the GOM. Large gulls such as HERG, GBBG, and laughing gulls (*L. atricill*; LAGU) commonly search for easy, reliable foraging opportunities and therefore are attracted to vessels that commonly discard offal or bycatch (Schwemmer & Garthe 2005). Only four HERG ever displayed the behavior of “Following a Vessel” (code #32), all located in the south quadrat. Two were at one meter, and one each followed at five and 10m. All four followed *our* research vessel despite there being two working lobster vessels recorded during our survey, one each in the north and south quadrats.



Map 12. Location of foraging bird species throughout the season

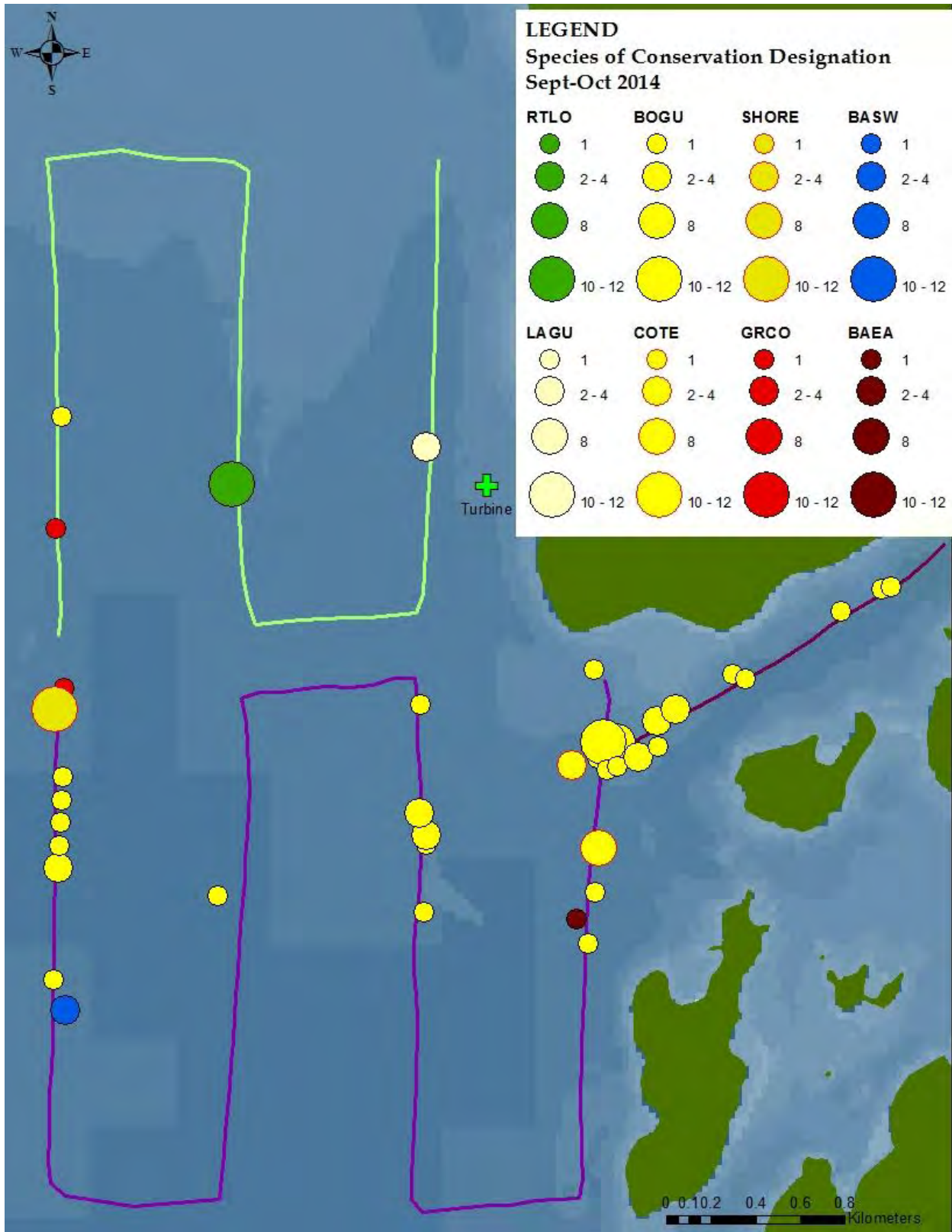
#### **D. ENDANGERED, THREATENED, AND BIRDS OF CONSERVATION CONCERN**

There are two ESA-listed birds that have the potential to occur in the project area, but none were definitively observed, or potentially observed, during these surveys: federally endangered roseate tern (*Sterna dougallii*), federally threatened piping plover (*Charadrius melodus*), and the red knot (*Calidris canutus*) that is a candidate species for federal listing. A number of bird species are also listed under the Maine ESA (MDIFW). In addition, the U.S. Fish & Wildlife Service (USFWS) created a list of species requiring special conservation action and awareness: the *Birds of Conservation Concern 2008* (BCC 2008). The MDIFW also has their list of species of special concern that identifies vulnerable species, which will be identified hereafter as SSC. Again, for ease of discussion when combining all special conservation designations, which contain federal, state, and concerning species, *SCC* will be used.

Bird species of these conservation designations are discussed in this following section and are shown in [Map 13](#). Previously, [Table 4](#) provided the list of all SCC observed during these surveys and include a total of 98 birds of these conservation designations. Observed during the Castine Test Site surveys from September 3 through October 1, 2014 only one confirmed State-Listed species was identified. This included two GRCO as State Threatened under the MDIFW's Maine Endangered Species Act (MESA) of 1975. Other observed species potentially falling into the Federally- or State-Listed category were recorded as a single flock of "unidentified shorebirds" (n=12). A selection of these species in this designation *that have the potential to occur within our survey area* include but are not limited to the lesser yellowlegs (*Tringa flavipes*), whimbrel (*Numenius phaeopus*), semipalmated sandpiper (*Calidris pusilla*), upland sandpiper (*Bartramia longicauda*), red knot, and the piping plover.

Regarding the *Birds of Conservation Concern 2008* (BCC 2008) list, observed species of this designation included 10 RTLO and one BAEA. Found on MDIFW's SSC list were two LAGU, 58 BOGU, 11 COTE, and two barn swallows (*Hirundo rustica*; BASW).

Total numbers of every species per quadrat and density, and overall count and density, was presented in [Table 3](#), with SCC denoted by red text. Bonaparte's gulls were the third most abundant of all birds identified (6.2 birds/km<sup>2</sup>), yet the most numerous of the SCC. Common terns, second most abundant of SCC, were the eighth most abundant bird species observed in the Castine Test Site overall, with 0.9 birds/km<sup>2</sup>. Within the north quadrat, 13% of the total bird count consisted of SCC (n=14; 0.42/km<sup>2</sup>), 18% comprised the south (n=58; 0.85/km<sup>2</sup>), and 20% were in the BR (n=26; 10.2/km<sup>2</sup>).



Map 13. Species of Conservation Concern observed from Sept to Oct 2014.

Seen below, [Figure 4](#) shows the summary of these species of concern and the behaviors they were observed performing. Seven particular behavior types were observed by these SCC birds, which included the following: 1- sitting on the water; 20- direct flight; 35- milling; 48- meandering; 61- pattering; 65- scavenging while sitting; and 70- underwater pursuit. Of these behaviors among the SCC birds, sitting on the water was the most common with 24% followed closely by pattering (23%) and direct flight (22%). Forty-two percent of flying-associated behaviors by these SCC were at or below three meters. Thirty-four percent (n=24) of all SCC were recorded as flying within the Rotor-Sweep Zone of 10-20m, which included one BAEA and one BOGU at 10m in the south, and a single flock of 12 unidentified shorebirds that flew in the south quadrat at 20m and a single flock of 10 RTLO that flew in the north quadrat at 15m.

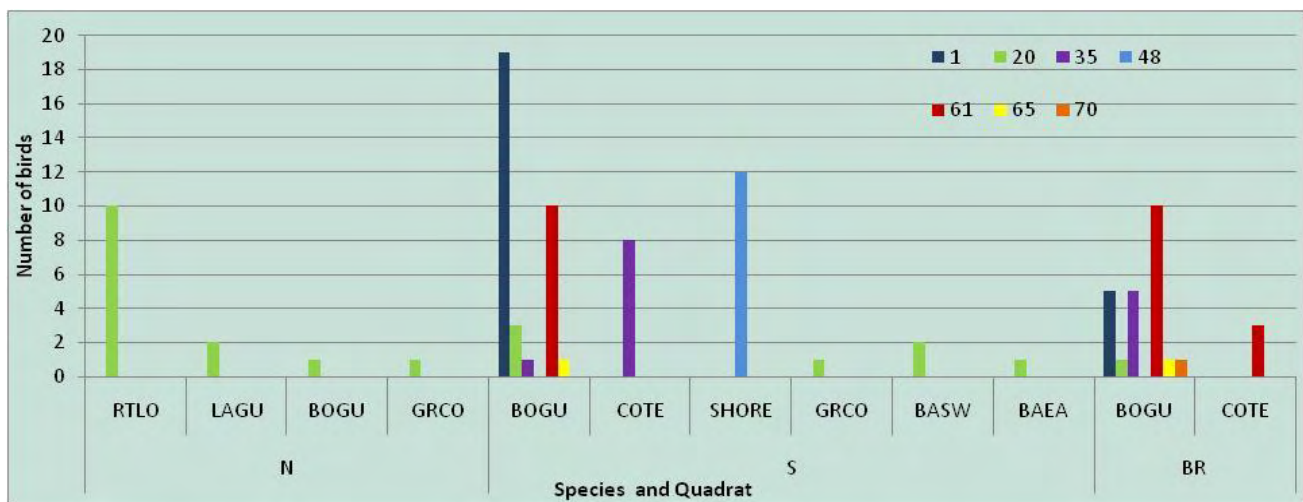


Figure 4. Behaviors displayed by SCC in each Quadrat.

## E. MARINE MAMMALS & OTHER NON-BIRD SPECIES SUMMARY

A complete list of all species observed was provided in [Table 3](#), summarizing the species and the dates on which they were documented. No baleen whales, large fish, or sea turtles were observed. Of the five survey days, harbor seals were observed on four of them, totaling 0.14/km<sup>2</sup> (n=12). Harbor porpoise were observed on three of the five days, totaling 0.12/km<sup>2</sup> (n=10). [Table 17](#) summarizes the seals and porpoise by quadrat. Harbor seals were more abundant in the north quadrat and harbor porpoise were more abundant in the south quadrat, as seen in [Map 14](#).

Table 17. Marine mammals by date and quadrat.

Species	N	S	BR	Total
HSEAL	6	5	1	12
HAPO	2	7	1	10
<b>Grand Total</b>	<b>8</b>	<b>12</b>	<b>2</b>	<b>22</b>





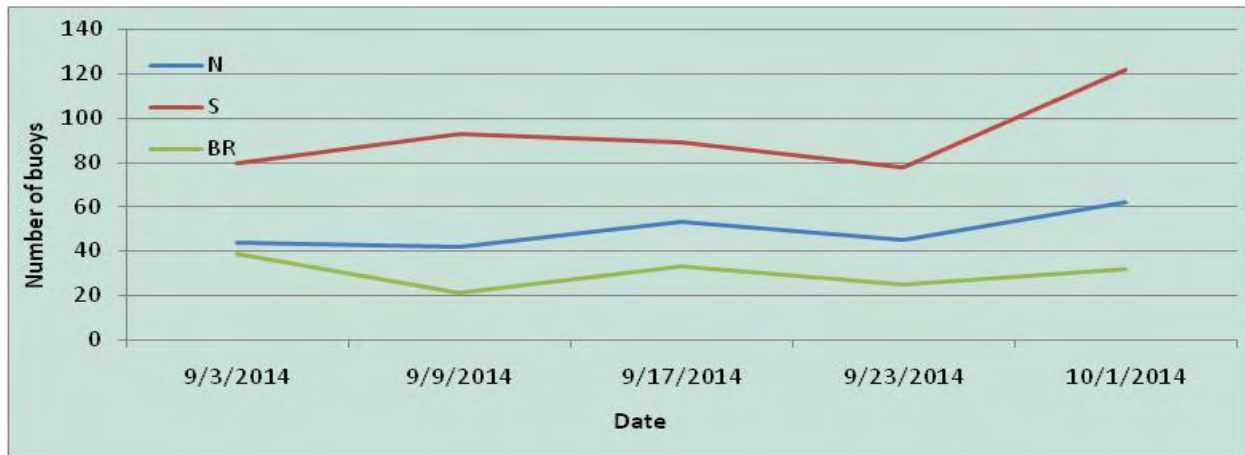
Map 14. Marine mammals observed from Sept to Oct 2014.

## **F. BOATS & BUOY OBSERVATIONS**

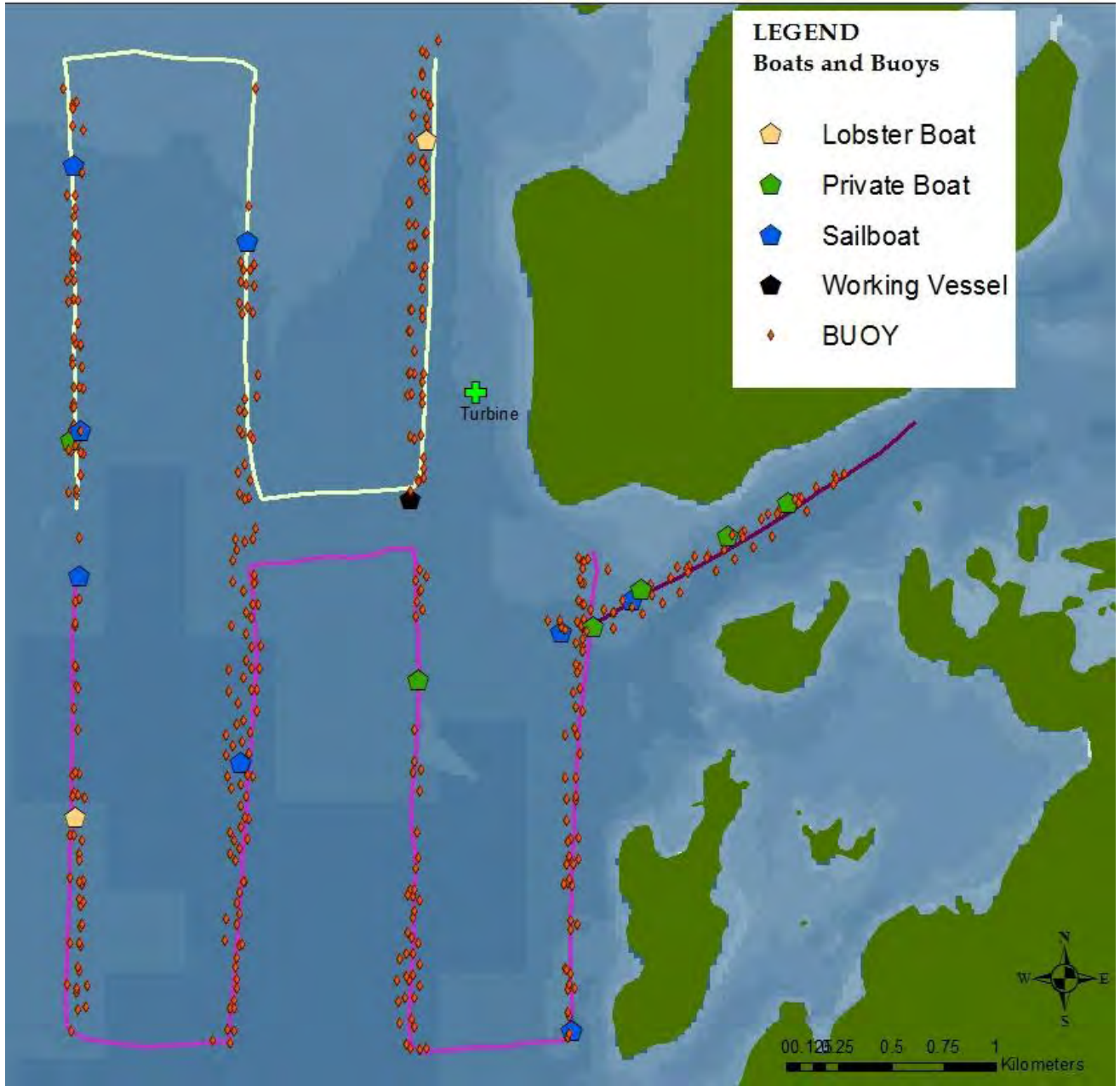
Observations of boat traffic and lobster buoy presence were recorded during the surveys in 2014. A total of 18 boats were observed while surveys were performed, with the breakdown of vessel type found in [Table 18](#), below. [Figure 5](#) provides a breakdown of the buoy count in each of the quadrats. Numbers of buoys remained relatively stable as the season progressed, with a slight increase from the September 23<sup>rd</sup> survey until the final survey on October 1<sup>st</sup>. [Map 15](#) shows buoy concentrations throughout the entire season.

[Table 18](#). Vessel type recorded in the Castine Test Site.

Boat Type	N	S	BR	Total
Lobster	1	1		2
Private	1	1	4	6
Sailboat	3	4	2	9
Working/MMA	1			1
<b>Grand Total</b>	<b>6</b>	<b>6</b>	<b>6</b>	<b>18</b>



[Figure 5](#). Numbers of lobster buoys in each quadrat, by date.



Map 15. Boat and Buoy distribution across the entire survey season.

## V. SUMMARY

This particular survey period from September to October 1<sup>st</sup> of 2014 included five boat-based visual surveys performed during the continuing deployment of the single 1/8<sup>th</sup> commercial scale VoltturnUS 20kW wind turbine on a semi-submersible floating platform at the University of Maine's Castine Harbor Dice Head Test Site. These surveys were performed at a rate of one per week. Data were gathered on species of birds and all other present wildlife such as marine mammals to include location, occurrence, numbers, behaviors, flight direction, and flight heights.

The previous sections of this report summarized the species numbers and activities by date and behavior categories, presented maps and tables of their sightings, and summarized species that are listed as a species of conservation designation, and other observations. Revisiting each of the project's objectives, these following sections will further summarize the highlights of this season's surveys.

### ***Objective #1: Determining bird and marine wildlife species compositions and their current activities and habitat use of the Castine Test Site.***

The overall count for individual birds throughout the entire Castine Test Site surveys was 559 and 22 marine mammals. In Part IV: Results, [Table 3](#) provided abundances, densities, and common behaviors of each survey quadrat's birds and marine mammals. Recorded in the north quadrat were a total of 12 identifiable species of birds (n=109), and two species of marine mammals (n=8). The south quadrat had 15 species of birds (n=318), and two marine mammals (n=12). The Bagaduce River quadrat had 11 identified species of birds (n=132), and two marine mammal species (n=2). The BR by far had the greatest overall density of birds (51.6/km<sup>2</sup>), followed by the south (4.7/km<sup>2</sup>) and the north (3.2/km<sup>2</sup>).

Twenty-two species of birds were documented throughout the entire Castine Test Site. Although total abundance of each species ranked HERG, BLGU, BOGU, and DCCO as the top four species in order of greatest to lesser (previously in [Table 15a](#)), densities per square kilometer show only HERG listed as ranking consecutively as the most common species across all three quadrats ([Tables 15b, c, & d](#)). [Figure 6](#) shows the Order-Grouping distribution across the season, by date. The only notable group during this period was Group 2: Charadriiformes which remained the most abundant group throughout the five survey days.

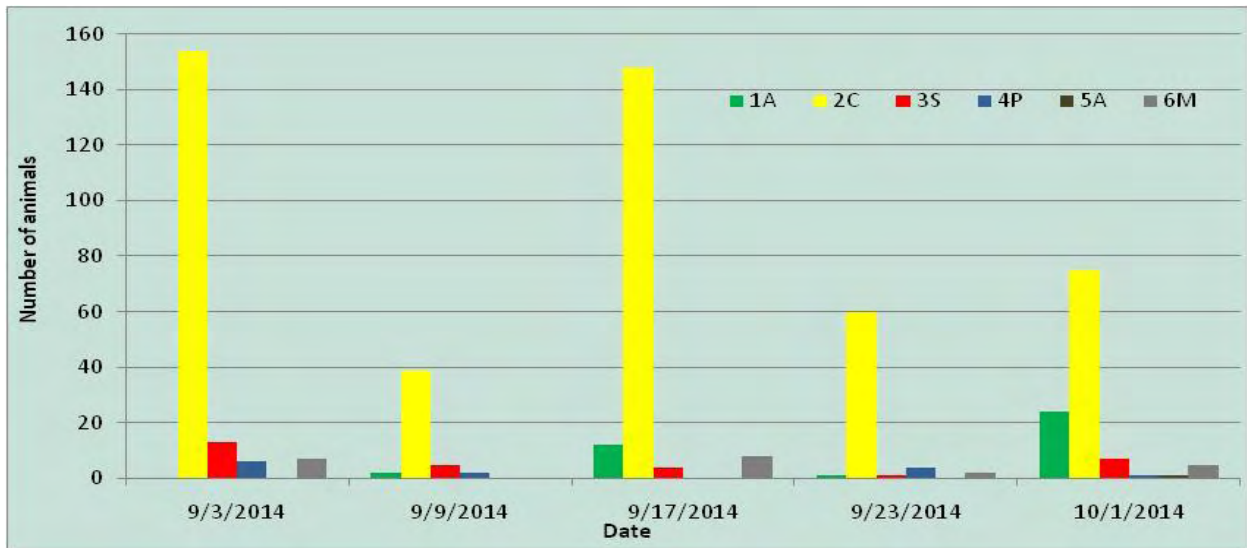


Figure 6. Numbers per Species-Group by date throughout the Castine Test Site.

The most common avian activities observed throughout the entire Castine Test Site were sitting (48%), followed by direct flight (19%) and these behaviors were also the two most commonly observed throughout the separate quadrats except in the south quadrat where milling was second and direct flight was third (previously in Table 16). The next most common behaviors varied in each of the quadrats. Forty-eight percent of all flying heights occurred at one to three meters but 27% of birds flew within the Rotor-Sweep Zone between 10-20m, as indicated in the red box in Figure 7.

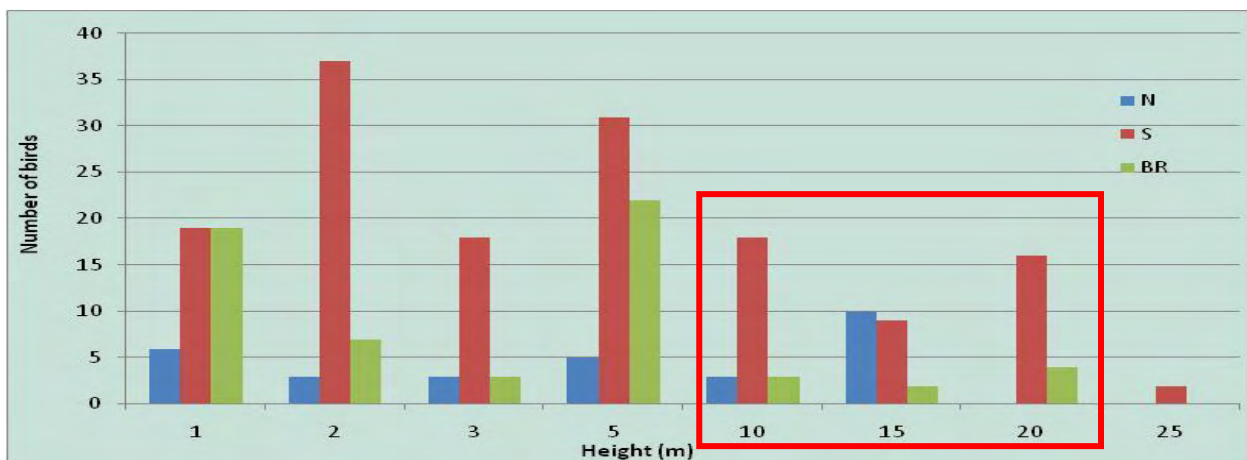


Figure 7. Flight heights of birds by quadrat throughout the Castine Test Site.

Bird Order-Groupings revealed only a few notable differences among behaviors observed. Within both Groups 1A and 2C, the vast majority of the birds sat in the water (62% and 50%, respectively). The next most common behavior for these groups involved

direct flight, with 1A mostly flying at 15m, and 2C mostly at five and 10m. Group 3S mostly flew at one meter and Group 4P all flew direct, with 33% flying at 15m. Figure 8 shows each species group and their typical behaviors and flight heights.

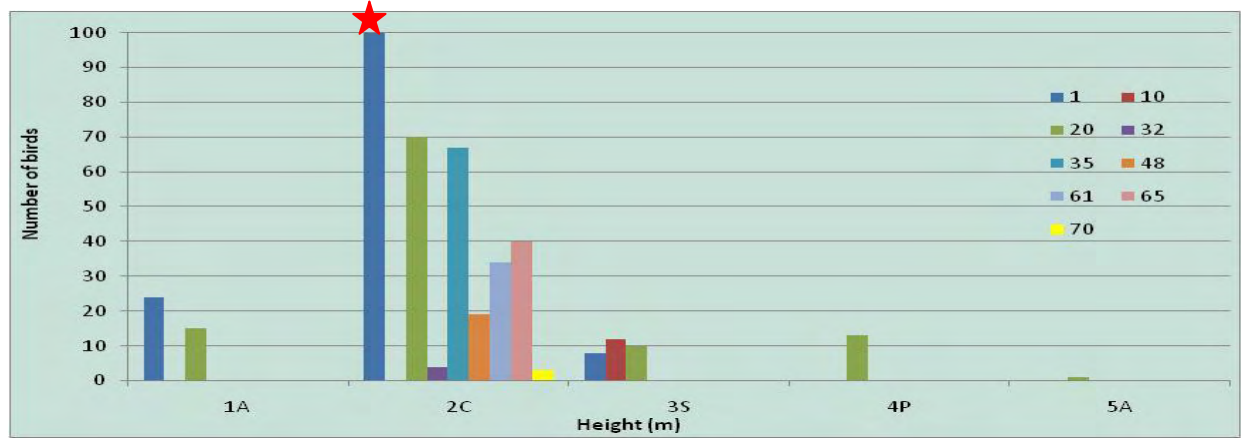


Figure 8. Behavior types of Order-Groups throughout the Castine Test Site. The red star indicates 239 of Group 2C sitting on the water.

In summary of foraging behaviors across the four major Order-Grouping represented in this survey, foragers only involved Group 2: Charadriiformes. A higher percentage of foraging birds were found in the south quadrat (69%), followed by the BR quadrat (18%). Milling involved 47% and scavenging was the second most common foraging behavior with 28%. As seen previously in Map 11a and Map 12 the greater varieties and densities of bird species were found along the south quadrat’s eastern-most line, into the Bagaduce River, and along the north quadrat’s eastern-most line. This is very likely attributed to the nearness to land and churning currents due to tidal changes that lead to greater foraging opportunities for these birds.

Endangered, threatened, and Birds of Conservation Concern (SCC) sightings included GRCO (State-Threatened; n=2, 0.098/km<sup>2</sup>), a single flock of 12 unidentified shorebirds (may or may not have been a Federally- or State-Threatened species); 10 RTLO and one BAEA (BCC USFWS); and two LAGU, 58 BOGU, 11 COTE, and two BASW (SSC MDIFW). Within the north quadrat, 13% of the total bird count consisted of SCC (n=14; 0.42/km<sup>2</sup>), 18% comprised the south (n=58; 0.85/km<sup>2</sup>), and 20% were in the BR (n=26; 10.2/km<sup>2</sup>). Bonaparte’s gulls were the most abundant of the SCC followed by COTE. Sitting on the water (24%) was the most common behavior by SCC followed closely by pattering (23%) and direct flight (22%). Forty-two percent of flying-associated behaviors by these SCC were at or below three meters. Thirty-four percent (n=24) of all SCC were recorded as flying within the Rotor-Sweep Zone of 10-20m, which included one BAEA and one BOGU (Figure 4).

***Objective #2: Use on-going baseline inventory of the species composition, behaviors, and habitat use to assess potential risks to the wildlife in relation to the VoltturnUS 1/8<sup>th</sup> scale turbine at the Castine Test Site.***

Although five previous studies have been conducted at this Castine Test Site, they will neither be discussed nor compared to the results of this current survey.

Birds may experience four major types of impact caused by offshore wind farms: direct collision, displacement due to disturbance, displacement due to the barrier effect, and direct habitat loss (Drewitt & Langston 2006, Goodale & Divoll 2009). A fifth impact involves habitat enhancement due to the underwater structure acting as an artificial reef and potentially attracting piscivorous seabirds; however this can only be a net benefit if the birds are not frightened away or killed by the structure itself (Drewitt & Langston 2006). In the case of the Castine Harbor Dice Head Test Site, the 1/8<sup>th</sup> scale structure, and the data presented in this portion of the project, is relatively small in both spatial and temporal contexts. Nevertheless, discussion will follow that summarizes any potential impact that the single 20kW 1/8<sup>th</sup> scale test turbine on a floating platform may present to wildlife at the University of Maine's Castine Test Site.

Current literature discusses how the probability of impacts from wind turbines, particularly with collisions, is more dependent upon individual species and their unique behaviors (Drewitt & Langston 2006, Ferrer et al. 2012, Fox et al. 2006, Furness & Wade 2012). These considerations should also take into account the local topographic factors which influence wind patterns and prey availability, as opposed to the common investigation of local abundance (Ferrer et al. 2012); together these factors influence the behavior of the individual birds at that moment in time.

More frequently, lighter winds blow through the upper Penobscot Bay area where the turbine is located; only one of the five days involved the turbine in motion. This minimizes the potential impact of injury or death with a swiftly moving object through the air. It is widely understood, however, that birds are documented as colliding with a wide variety of stationary man-made objects. These have included lighthouses, bridges, windows, high wires, etc., and flying birds particularly become susceptible under poor visibility and environmental conditions (Fox et al. 2006).

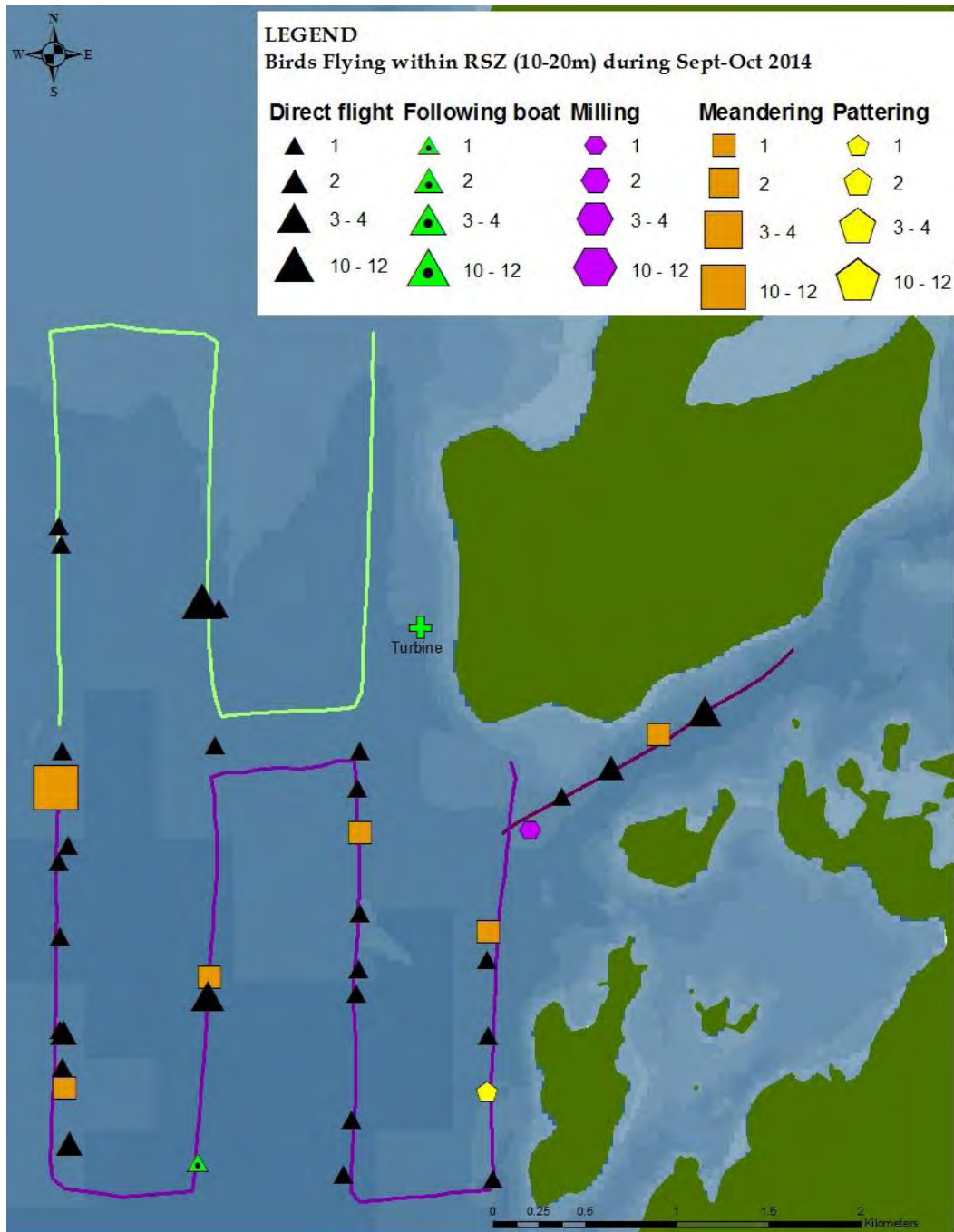
Numerous Wind farm Sensitivity Index (WSI) studies in Europe and North America generally agree that the species most affected by offshore wind farms include gulls, grebes, loons, seaducks, and migrating waterfowl and passerines (Drewitt & Langston 2006, Garthe & Hüppop 2004). Radar studies at a Danish location revealed significant avoidance

behavior (by a factor of 4.5) within the wind farm array by geese and common eider, and increasing their distance to the turbines, thereby reducing the risk of collision (Desholm & Kahlert 2005). A newer analysis by Furness & Wade categorized impacts to particular species, concluding high disturbance scores for common eider, loons, and scoter species because they are easily disturbed and have a high tendency to flush; high collision impact scores for gulls, terns, and loons; and high overall disturbance and displacement scores for loons, sea ducks, and alcids (Furness & Wade 2012). Common eider was the sixth most abundant species overall observed throughout the Castine Test Site, although only found sitting in the BR as a single flock of 12 on October 1. Common loons were the ninth most abundant overall, whose numbers increased as the surveys progressed, with the majority of them in the north quadrat. Red-throated loons were the 10<sup>th</sup> most common bird but only recorded on one occasion flying in the north quadrat. Only two CANG were recorded on a single event, sitting in the BR. Of the A1: Anseriformes, 87% flew in the north quadrat, which is the quadrat in which the VoltturnUS turbine is located. Group 2C had only 6%, 3S had 10%, 4P had 15%, and 5A had none flying in the north quadrat. Because of these findings loons could experience a minor risk of collision, although the probability is likely not highly significant.

Flight height was determined to be a substantial factor in assessing collision probabilities by Furness & Wade in their review of Scottish seabird sensitivity to offshore wind farms (2012). It is discussed by Dierschke and Daniels that over 90% of loons, sea ducks, gulls, and terns habitually fly higher over the ocean (at or below 50m) and are more likely to be at the heights at which this turbine's blades would be spinning, thereby putting them more at risk (Dierschke & Daniels 2003 *in* Furness & Wade 2012). The single VoltturnUS 20kW wind turbine on a 1/8<sup>th</sup> commercial scale semi-submersible floating platform that was deployed on June 6, 2013 has a hub height measuring 50ft (15.24m), with a rotor diameter of 31.5ft (9.6m) and RSZ between 10-20m. For purposes of bird collision and other risks, it is necessary to consider the Castine Test Site avian flight activity in this flight height-zone, regardless of the blades spinning or not. Bird species found flying at this height included loons (n=11), gulls (n=34), the flock of 12 shorebirds, two cormorants, five American crows (*Corvus brachyrhynchos*; AMCR), and an eagle, totaling 28%, and seen below in Map 16. Within our eight species of conservation status, none were documented as flying within the RSZ of 10- 20m above the water. A red box indicates flying birds found within the 10- to 20m zone in both Figure 3 (for foragers) and Figure 7 (all flying birds). Within this RSZ, foraging species involved only two HERG, totaling 1.4% of all foraging birds. When reviewing the locality of the foraging birds in "S1" of the south quadrat and the BR, the abundance and distribution of foraging birds being at risk from the slowly rotating turbine blades is minimal. The flock of shorebirds flew at 20m but was only found in "S4" of the south quadrat, the greatest distance from the turbine possible within the survey area. The cormorants, crows, and eagle were also found at a significant distance



from the turbine while flying within this RSZ. Although gulls included the greatest abundance of the birds flying at RSZ, their distribution across the entire Castine Test Site survey area also reveals a minimal risk of collision. Of the 11 loons, 10 RTLO flew at 15m in the “N2” section of the north quadrat, relatively near the turbine, comprising the only species performing activity within parameters that may reveal a risk of collision for these particular loon species in this area.



Map 16. Birds flying within the 10-20m RSZ of the 1/8<sup>th</sup> scale VolturnUS semi-submersible floating turbine.

Other seasonal factors should objectively be considered in the analyses regarding behaviors of gulls, terns, sea ducks, and cormorants that are described as susceptible to disturbance by turbines (Drewitt & Langston 2006, Fox et al. 2006). With the Bagaduce River Watershed and the Holbrook Island Sanctuary in the near vicinity of this Castine Test Site, it is essential that breeding bird species are given particular consideration for their use of this “Focus Area of Ecological Significance” (BwH 2012). Of the 21 identified bird species from our survey that were also identified on the “Checklist of the Birds” for the Holbrook Island Sanctuary, nine of these are known to breed in the area (Holbrook Island Sanctuary, 2001). However, due to the timing of these surveys occurring in late fall, this is not a factor that has concern for these species.

At a study of ecological changes at a windfarm off the shore of the Netherlands, numbers of gulls, terns, and cormorants increased as the birds actively used the area for foraging (Lindeboom et al. 2011 *in* Furness & Wade 2012). A similar increase in gulls and terns at the Horns Rev windfarm was also documented (Petersen et al. 2004 *in* Fox et al. 2006). Although the cause was not clear regarding the increased numbers of HERG and terns at the Horns Rev wind farm in Denmark post construction (Drewitt & Langston 2006), explanation may have included increased loafing structures, increased fish abundance due to habitat modification, increased boat traffic looking like potential food sources, or a combination of any of these factors (Fox et al. 2006). For this reason, gulls in the Castine Test Site could be attracted to the turbine itself for a loafing structure, or for potentially increased foraging opportunities resulting from either increased boat traffic, or if the underwater structures and sea floor anchor disturbance create ideal habitat for fish, thereby increasing foraging piscivorous bird species (Fox et al. 2006). As discussed previously, only two HERG foraged at heights within the RSZ and these included only 1.4% of all flying birds. All other gulls were observed foraging mostly in the “S1” and “N3” portions of the quadrats, which are both near land. As seen in Map 12, a single flock of 10 RBGU scavenged in “N3” which was the closest and most significant activity to the floating turbine. Only two LAGU flew direct at two meters above the water also near the turbine, as seen in Map 13 and Table 6. As seen by all the activity in “S1” and “N3,” and most times in the BR, the churning of the water at the mouth of the Bagaduce River at the changing of the tides provides an ideal foraging situation. This is more likely the cause of the greater numbers of birds sitting and foraging in these areas and less likely caused by the turbine and its underwater structure providing added habitat for foraging opportunities.

Gulls are well known for investigating boats for the opportunity of finding easy food from discards (Schwemmer & Garthe 2005); this likely accounts for the four gulls that were observed following our survey vessel. All occurred in the south quadrat, located specifically within strips “S2,” “S3,” and “S4.” Again, these numbers reveal a minimal cause for concern

regarding the phenomenon of the turbine structure or increased human boat activity attracting these species of birds to the VoltornUS 1/8<sup>th</sup> scale turbine.

Again, of all the eight SCC observed from September to October of 2014, only the RTLO were found more often in the north quadrat and flying within the RSZ, thereby being the most at risk for collision impacts with the structure. Foraging activity (scavenging while sitting) by the 10 RBGU in the vicinity of the turbine also makes these gull species potentially at risk to collision due to their distraction while flying as they forage and not paying attention to the rotating blades. Other species such as seaducks, grebes, waterfowl, alcids, and geese were shown to be disturbed easily by or avoid turbine activity (Drewitt & Langston 2006, Garthe & Hüppop 2004, Desholm & Kahlert 2005). This phenomena presented similar results, or did not disprove otherwise, this trend during our surveys; all two Canada geese (*Branta canadensis*) and COEI were observed only in the BR, and the majority of BLGU were found in the south and BR quadrats, thereby reducing any risk of these species being injured by the blades or structure during this time period.

Although abundance alone is not a factor of concern for impact to the birds of the University of Maine's VoltornUS 1/8<sup>th</sup> scale Test Turbine Site, the consistently higher numbers of gulls observed continually throughout all Castine Test Site surveys will continue to be an interesting subset of data to observe. Due to carcasses sinking or being consumed by opportunistic predators, detection probabilities are low for birds that may be killed by collision, if they do occur with this single 20kW 1/8<sup>th</sup> scale floating turbine.

Maine-specific considerations for wind farm development have been suggested by the BioDiversity Research Institute to include three main criteria: 1) avoid critical breeding, wintering, and migratory areas, 2) avoid offshore islands that provide breeding areas for seabirds and are essential migratory staging areas, and 3) avoid areas within three kilometers (1.86mi) of these first two criteria to prevent serious impact to birds of special concern (Goodale & Divoll 2009). The Castine area is near the Holbrook Island Sanctuary and the Bagaduce River Watershed, renowned for its Essential Habitat status (BwH 2012) for many species of birds that include BAEA, osprey (*Pandion haliaetus*), DCCO, and various ducks and waterfowl. Within this vicinity of the Castine Test Site, the breeding species observed during our surveys included DCCO, HERG, great black-backed gull (*L. marinus*), BLGU, COEI, BAEA, AMCR, ruby-throated hummingbird (*Archilochus colubris*), and BASW. Of these birds, only the one BAEA (BCC & SSC), and two BASW (SSC) are considered a SCC and they were only ever recorded from within the south quadrat and in small numbers.

Due to the significant habitat of the Bagaduce River Watershed and the Castine area of Penobscot Bay for birds at all times of the year, this has been a successful project surveying for birds and all other wildlife in association with the University of Maine's

VolturnUS 1/8<sup>th</sup> scale floating test turbine. We have made every effort to best evaluate the ongoing effects and/or habituation that may or may not have occurred, with particular consideration given to changes in avian species composition, abundance, and behavior. These surveys are one of the first known studies of pre-deployment species composition and behavior for an offshore floating wind turbine with a tension leg design. They are essential to an understanding of the impact of alternative energy development projects, therefore streamlining their appropriate use and cooperatively mitigating the resulting impacts will benefit both humans and seabirds within this next decade.

## **ACKNOWLEDGEMENTS**

I would sincerely like to thank Maine Maritime Academy and the dedicated captains Zander Parker and Derek Chase, as well as the supporting deck hands and staff, whose accommodating spirit and generosity has made this project feasible. Additional support and mentoring is owed to Gordon Longfellow at the College of the Atlantic. The most thanks goes to Dr. Damian Brady Russell Edgar, and Donna Darling for their logistical, professional, and encouraging support. They are the catalysts that keep a worthy project afloat. Thank you.

# APPENDIX 1

## SURVEY CODES

(Gould & Forsell 1989)

### Code 2. Survey Type (15)

- 1 = General observations: These are records of large flocks, rare or unusual sightings, transects that cannot be used to derive density indexes, or any record that will not fit another format.
- 7 = Station count: The criteria for a station count are that the platform is stationary and that all birds are counted in a 360° circle from the platform.
- 9 = Ocean transect: The criteria for a transect are a visibility of at least 1,000m and a moving platform with a constant speed and direction. An oceanic-transect is conducted outside well-defined headlands.

### Code 3. Observation Conditions (75)

- 1 = Bad (general observations only)
- 2 = Poor (no quantitative analysis)
- 3 = Fair
- 4 = Average
- 5 = Good
- 6 = Excellent
- 7 = Maximum

### Code 5. Sea State (49)

- 0 = Calm
- 1 = Rippled (0.0 1-0.25 ft)
- 2 = Wavelet (0.26-2.0 ft)
- 3 = Slight (2-4 ft)
- 4 = Moderate (4-8 ft)
- 5 = Rough (8-13 ft)
- 6 = Very rough (13-20 ft)
- 7 = High (20-30 ft)
- 8 = Over 30 ft

### Code 6. Weather (55-56)

- 00 = Clear to partly cloudy (0-50% cloud cover)
- 03 = Cloudy to overcast (51-100% cloud cover)
- 41 = Fog (patchy)
- 43 = Fog (solid)
- 68 = Rain
- 71 = Snow
- 87 = Hail

### Code 14. Age (32)

- P = Pullus (flightless young)
- J = Hatching year (hatching date to spring molt: a bird capable of sustained flight)
- S = Subadult (last year before adult plumage)
- A = Adult

### Code 17. Bird Behavior (56-57)

- 00 = Undetermined
- 01 = Sitting on water
- 10 = Sitting on floating object
- 15 = Sitting on land
- 20 = Flying in direct & consistent heading
- 29 = Flying, height variable
- 31 = Flying, circling ship
- 32 = Flying, following ship
- 34 = Flying, being pirated
- 35 = Flying, milling or circling (foraging)
- 48 = Flying, meandering
- 61 = Feeding at or near surface while flying (dipping or pattering)
- 65 = Feeding at surface (scavenging)
- 66 = Feeding at or near surface, not diving or flying (surface seizing)
- 70 = Feeding below surface (pursuit diving)
- 71 = Feeding below surface (plunge diving)
- 82 = Feeding above surface (pirating)
- 90 = Courtship display
- 98 = Dead

### Code 18. Mammal Behavior (56-57)

- 00 = Undetermined
- 01 = Leaping
- 02 = Feeding
- 03 = Mother with young
- 04 = Synchronous diving
- 05 = Bow riding
- 06 = Porpoising
- 07 = Hauled out
- 08 = Sleeping
- 09 = Avoidance
- 14 = Curious/following
- 15 = Cetacea/pinniped association
- 16 = Pinniped/bird association
- 17 = Cetacea/bird association
- 18 = Breeding/copulation
- 19 = Moribund/dead

## APPENDIX 2: Species codes, Latin name, dates, abundances, and densities.

Species	Latin Name	September				October	Total	
		9/3	9/9	9/17	9/23	10/1		
COLO	<i>Gavia immer</i>		1	2		9	12	0.77
RTLO	<i>G. stellata</i>			10			10	0.64
COEI	<i>Somateria mollissima</i>					12	12	0.77
BLSC	<i>Melanitta americana</i>				1	1	2	0.13
CAGO	<i>Branta canadensis</i>					2	2	0.13
RNGR	<i>Podiceps grisegena</i>		1				1	0.06
HERG	<i>Larus argentatus</i>	88	10	109	36	51	294	18.80
GBBG	<i>L. marinus</i>		1	1	1		3	0.19
BLKI	<i>Rissa tridactyla</i>	2					2	0.13
RBGU	<i>L. delawarensis</i>	37	2	7	3	1	50	3.20
LAGU	<i>L. atricilla</i>	2					2	0.13
BOGU	<i>Chroicocephalus philadelphia</i>	8	15	18	1	16	58	3.71
COTE	<i>Sterna hirundo</i>	11					11	0.70
BLGU	<i>Cephus grille</i>	6	11	13	7	7	44	2.81
SHORE					12		12	0.77
NOGA	<i>Morus bassanus</i>					1	1	0.06
GRCO	<i>Phalacrocorax carbo</i>	2					2	0.13
DCCO	<i>P. auritus</i>	11	5	4	1	6	27	1.73
AMCR	<i>Corvus brachyrhynchos</i>	2	2		4	1	9	0.58
BASW	<i>Hirundo rustica</i>	2					2	0.13
HUMM	<i>Archilochus colubris</i>	2					2	0.13
BAEA	<i>Haliaeetus leucocephalus</i>					1	1	0.06
Bird Total		173	48	164	66	108	559	
per km2		12.4	5.1	15.4	4.4	9.9		
HSEAL	<i>Phoca vitulina</i>	2		5	2	3	12	0.77
HAPO	<i>Phocoena phocoena</i>	5		3		2	10	0.64
MM Total		7		8	2	5	22	
per km2		0.45		0.58	0.10	0.24		

## LITERATURE CITED

- Beginning With Habitat. (2012) "Focus Areas of Statewide Ecological Significance: Bagaduce River," 5 pp. [http://www.maine.gov/doc/nrimc/mnap/focusarea/bagaduce\\_river\\_focus\\_area.pdf](http://www.maine.gov/doc/nrimc/mnap/focusarea/bagaduce_river_focus_area.pdf)
- Berleant, A. "\$1 million grant for Bagaduce River arrives with strings attached." *Castine Patriot*, April 5, 2012.
- Biodiversity Research Institute (2012). "Birds, Bats, and Coastal Windfarm Development in Coastal Maine: Preliminary Ranking of Bird Use." *Biodiversity Research Institute*. Retrieved July 29, 2012, from <http://www.briloon.org/oae/the-science-of-bri/tracking-wildlife/birds-bats-costal-windfarm-development>
- Drewitt, A.L. and R.H.W Langston. 2006. Assessing the impacts of wind farm on birds. *Ibis* 148: 29-42.
- Ferrer, M., M. de Lucas, G.F.E. Janss, E. Casado, A.R. Muñoz, M.J. Bechard, and C. P. Calabuig. 2012. Weak relationship between risk assessment studies and recorded mortality in wind farms. *Journal of Applied Ecology* 49: 38-46.
- Fox, A.D. M. Desholm, J. Kahlert, T. K. Chritensen, I.B.K. Petersen. 2006. Information needs to support environmental impact assessment of the effects of European marine offshore wind farms on birds. *Ibis* 148: 129-144.
- Furness, B. & H. Wade. 2012. Vulnerability of Scottish Seabirds to Offshore Wind Turbines. MacArthur Green Ltd., Glasgow. 39pp.
- Garthe, S. and O. Hüppop. 2004. Scaling possible adverse effects of marine wind farms on seabirds: developing and applying a vulnerability index. *Journal of Applied Ecology* 41: 724-734.
- Goodale, W. and T. Divoll. 2009. Birds, Bats and Coastal Wind Farm Development in Maine: A Literature Review. Report BRI 2009-18. BioDiversity Research Institute, Gorham, Maine.
- Gould, P.J. & D.J. Forsell. 1989. Techniques for shipboard surveys of marine birds. U.S. Fish & Wildlife Service, *Fish & Wildl. Technical Report* 25, 22 pp.
- Kennedy, L. & Holberton, R.L. 2012. "Visual Observations for Birds, Turtles, and Marine Mammals at the University of Maine Test Site off Monhegan Island, a report submitted to the Maine State Planning Office and University of Maine." Submitted January 2012. 52pp.
- Larsen, J.K. and M. Guillemette. 2007. Effects of wind turbines on flight behaviour of wintering common eiders: implications for habitat use and collision risk. *Journal of Applied Ecology* 44: 516-522.
- Maine's Department of Inland Fisheries & Wildlife (MDIFW) Endangered Species Program/Bird List [http://www.maine.gov/ifw/wildlife/species/endangered\\_species/bird\\_list.htm](http://www.maine.gov/ifw/wildlife/species/endangered_species/bird_list.htm)
- MDIFW Species of Special Concern. (<http://www.maine.gov/ifw/wildlife/endangered/specialconcern.htm#birds>)

- Maine Tidal Power Initiative's Site Resource Assessment (2011). Published Habitat Map: Bagaduce Narrows and Castine Harbor, Maine. "Significant Wildlife and Essential Habitats." *University of Maine: Maine Tidal Power Initiative*. Retrieved from the Maine DEP website: [http://www.maine.gov/dep/gis/datamaps/index.html#nrpa\\_bird](http://www.maine.gov/dep/gis/datamaps/index.html#nrpa_bird)
- Schwemmer, P. and S. Garthe. 2005. At-sea distribution and behavior of a surface-feeding seabird, the lesser black-backed gull *Larus fuscus*, and its association with different prey. *Marine Ecology Progress Series*. 285: 245-258.
- Tasker, M.L., P.H. Jones, T. Dixon, & B.F. Blake. 1984. Counting seabirds at sea from ships: A review of methods employed and a suggestion for a standardized approach. *The Auk* 101: 567-577.
- USFWS Species of Conservation Concern 2008 (U.S. Fish and Wildlife Service. 2008. Birds of Conservation Concern 2008. United States Department of Interior, Fish and Wildlife Service, Division of Migratory Bird Management, Arlington, Virginia. 85 pp. [Online version available at <https://www.fws.gov/migratorybirds/NewReportsPublications/SpecialTopics/BCC2008/BCC2008.pdf>]
- USFWS (January 9, 2012). **Guidance regarding use of the Wind Turbine Guidelines Advisory Committee's recommendations.** *Wind Turbine Guidelines Advisory Committee: Habitat and Resource Conservation*. Retrieved September 23, 2012, from [http://www.fws.gov/habitatconservation/windpower/wind turbine advisory committee.html](http://www.fws.gov/habitatconservation/windpower/wind_turbine_advisory_committee.html)



# 2012 Acoustic Bat Survey Report

Dice Head Lighthouse  
Castine, Maine

Prepared for

DeepCWind  
University of Maine  
Darling Marine Center  
193 Clark Cove Road  
Walpole, ME 04573

Prepared by

Stantec Consulting Services Inc.  
30 Park Drive  
Topsham, ME 04086



**Stantec**

August 2012

## Executive Summary

---

The DeepCWind Consortium, led by the University of Maine, is pursuing installation of a scaled down, floating wind turbine in the waters of the Gulf of Maine near Castine, Maine. As part of the permitting process for this test turbine, Stantec Consulting Services, Inc. (Stantec) conducted an acoustic bat survey between mid-May through early July, 2012. Surveys were conducted from the tower of the Dice Head Lighthouse in Castine, the nearest feasible monitoring location to the site at which the test turbine is to be deployed. Survey methods followed those used by similar assessments of bat activity for on-shore commercial wind projects and in offshore bat monitoring conducted by Stantec in the Gulf of Maine since 2009.

An acoustic detector was deployed on the tower of the Dice Head Lighthouse on May 22, 2012, and operated on a nightly basis through the night of July 10, 2012. A total of 797 bat call sequences were recorded during this period. Between 0 and 107 call sequences were recorded per night, with an overall activity level of 15.9 call sequences per detector-night. Bats were detected during 42 out of 50 surveyed nights (84 percent). Of the 797 recorded call sequences, 422 (53 percent) were identified to species or guild and the remaining 375 call fragments were too short to be identified but were classified as either high frequency or low frequency “unknown”. The BBSH guild, including the big brown bat (*Eptesicus fuscus*) and silver-haired bat (*Lasionycteris noctivagans*) was the most frequently identified guild, followed by bats in the *Myotis* genus. Eastern red bats (*Lasiurus borealis*) and hoary bats (*Lasiurus cinereus*) were also documented at the site.

## Table of Contents

<b>EXECUTIVE SUMMARY .....</b>	<b>E.1</b>
<b>1.0 INTRODUCTION.....</b>	<b>1</b>
<b>2.0 DATA COLLECTION METHODS .....</b>	<b>3</b>
<b>3.0 DATA ANALYSIS METHODS.....</b>	<b>3</b>
<b>4.0 RESULTS .....</b>	<b>6</b>
<b>5.0 DISCUSSION.....</b>	<b>9</b>
<b>6.0 LITERATURE CITED.....</b>	<b>11</b>

### Photos

Table 5-1	Dice Head Lighthouse, Castine, ME.
Table 5-2	Paired acoustic detector deployment.

### Figures

Figure 1-1	2012 Survey Location Map
Figure 4-1	Acoustic bat survey results by survey night during summer 2012 surveys at Dice Head Lighthouse in Castine, Maine.
Figure 4-2	Mean nightly temperature and relative humidity during summer 2012 surveys at Dice Head Lighthouse in Castine, Maine.
Figure 4-3	Nightly bat activity levels versus temperature (left) and relative humidity (right) during summer 2012 surveys at Dice Head Lighthouse in Castine, Maine.
Figure 4-4	Acoustic bat survey results by hour past sunset during summer 2012 surveys at Dice Head Lighthouse in Castine, Maine.
Figure 4-5	Acoustic bat survey results by guild during summer 2012 surveys at Dice Head Lighthouse in Castine, Maine.

### Appendices

Appendix A	Acoustic Bat Survey Data Tables
------------	---------------------------------

[PN195600798\\*](#)

*\* This report was prepared by Stantec Consulting Services Inc. for DeepCWind. The material in it reflects Stantec's judgment in light of the information available to it at the time of preparation. Any use which a third party makes of this report, or any reliance on or decisions made based on it, are the responsibility of such third parties. Stantec accepts no responsibility for damages, if any suffered, by any third party as a result of decisions made or actions based on this report.*

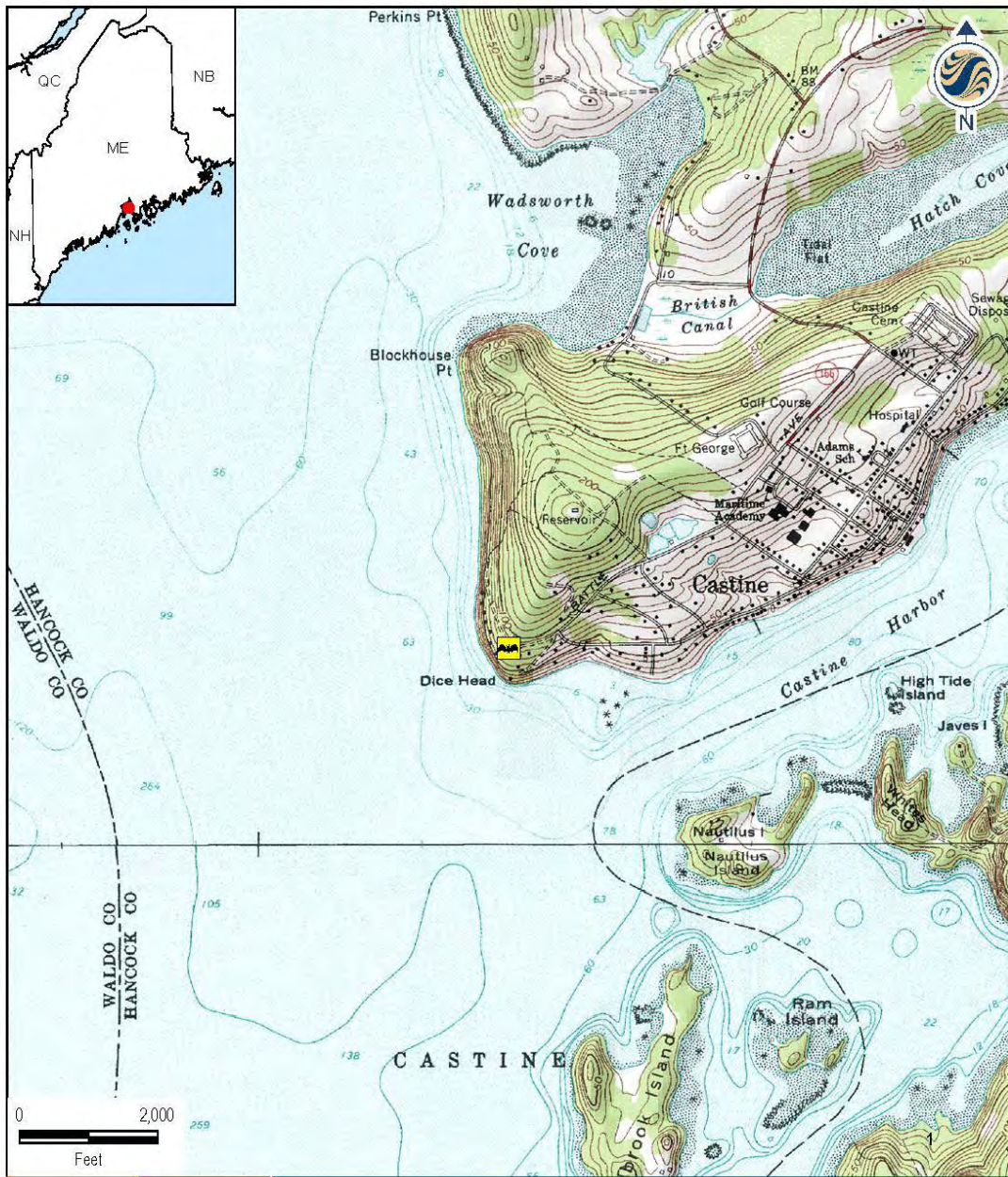
## 1.0 Introduction

---

The DeepCWind Consortium, led by the University of Maine, is pursuing installation of a scaled down, floating wind turbine in the waters of the Gulf of Maine near Castine, Maine. As part of the permitting process for this test turbine, Stantec Consulting Services, Inc. (Stantec) conducted an acoustic bat survey between mid-May through early July, 2012. Because no suitable floating platform from which to conduct acoustic surveys currently exists, acoustic bat surveys were conducted from the tower of the Dice Head Lighthouse in Castine, the nearest accessible location at which acoustic equipment could be deployed (Figure 1). Numerous acoustic bat surveys of this type have been similarly conducted to gauge patterns in acoustic bat activity at proposed wind projects onshore. Stantec has also been actively engaged since 2009 in long-term passive acoustic monitoring at up to eighteen shoreline/offshore locations in the Gulf of Maine using similar methods.

Bats use high frequency echolocation to maneuver through the landscape during migration or in search of food and water. Although the echolocation sounds produced by bats are above the frequency range of human hearing, electronic equipment can be used to record these high frequency sounds. Acoustic sampling of bat activity has become a standard pre-construction survey for proposed wind-energy development (Kunz *et al.* 2007). This type of sampling allows for long-term passive monitoring in a variety of habitat types and locations. Although acoustic surveys are associated with several major assumptions (Hayes 2000) and results cannot be used to determine the number of bats inhabiting an area, acoustic surveys can provide insight into patterns in bat activity, species composition, and use of an area.

Eight species of bats occur in Maine, based upon their normal geographical range. These are the little brown bat (*Myotis lucifugus*), northern long-eared bat, (*M. septentrionalis*), eastern small-footed bat (*M. leibii*), silver-haired bat (*Lasionycteris noctivagans*), tri-colored bat (*Perimyotis subflavus*), big brown bat (*Eptesicus fuscus*), eastern red bat (*Lasiurus borealis*), and hoary bat (*L. cinereus*) (DeGraaf and Yamasaki 2001). All eight species could potentially occur in the mid-coast region in which surveys took place and are able to be detected using acoustic bat detectors.




195600798



**Stantec Consulting Services Inc.**  
 30 Park Drive  
 Topsham, ME USA  
 04086  
 Phone (207) 729-1199  
 Fax: (207) 729-2715  
 www.stantec.com

**Legend**

 Acoustic Bat Survey Location

**Client/Project**  
 University of Maine  
 Dice Head Bat Survey  
 Castine, Maine

Figure No.

1

Title

**Project Location Map**

August 2, 2012

00798\_001\_Locus.mxd

## 2.0 Data Collection Methods

---

One acoustic detector system consisting of a primary and backup detector was deployed on the platform of the Dice Head Lighthouse tower at a height of approximately 14 meters (m) above ground level. The lighthouse is located approximately 85 m from the high tide mark and is surrounded by habitat consisting of a mix of deciduous and coniferous trees, developed residential lawns, and light residential development. The lighthouse is attached to an occupied residence with a maintained lawn (Photo 2-1).

Anabat SDI detectors (Titley Electronics Pty Ltd.) were used for data collection based upon their widespread use for this type of survey, their ability to be deployed for long periods of time, and their ability to detect a broad frequency range, allowing detection of all species of bats that could occur in Maine. Anabat detectors are frequency division detectors, dividing the frequency of echolocation sounds made by bats by a factor of 16 and then recording these sounds onto removable compact flash cards for subsequent analysis. Detectors were programmed to begin monitoring at 18:00 hours each night and end monitoring at 08:00 hours each morning. The audio sensitivity setting of each Anabat system was set between 6 and 7 (on a scale of 1 to 10) to maximize sensitivity while limiting ambient background noise and interference. The sensitivity of individual detectors was then tested using an ultrasonic Bat Chirp (Reno, NV) to determine that the detectors would be able to detect bats up to a distance of at least 10 m (33').

The acoustic system consisted of two SD1 detectors, powered by a single 12-volt battery charged by two 10-watt solar panels. The SD1 detectors were deployed in separate waterproof housings with a 90 degree PVC elbow used to direct bat calls into the microphone while protecting the units from the weather (Photo 2-2). This standardized system has been used at the majority of long-term acoustic bat surveys conducted by Stantec. Temperature and relative humidity were measured at the survey site using a datalogger set to record at 15-minute intervals (Onset, HOBO model Pro V2 U23-001).

## 3.0 Data analysis methods

---

Ultrasound recordings of bat echolocation may be broken into recordings of a single bat call or recordings of bat call sequences. A call is a single pulse of sound produced by a bat, while a call sequence is a combination of two or more pulses recorded in an Anabat file. Recordings containing less than two calls were eliminated from analysis as has been done in similar studies (Arnett *et al.* 2006). Call sequences typically include a series of calls characteristic of normal flight or prey location ("search phase") and capture periods (feeding "buzzes").

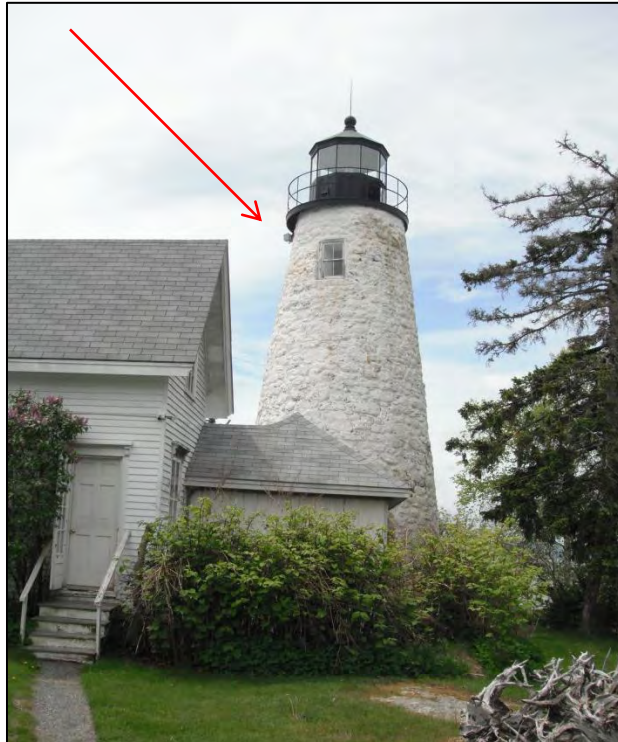


Photo 2-1. Dice Head Lighthouse, Castine, ME. Red arrow depicts location of paired detectors.



Photo 2-2. Paired acoustic detector deployment. Note: Unit is lashed to tower railing to avoid potential damages in accordance with Maine Historical Preservation Commission recommendations.

Potential call files were extracted from data files using CFCread<sup>†</sup> software. The default settings for CFCread<sup>†</sup> were used during this file extraction process, as these settings are recommended for the calls that are characteristic of bats in the Northeast. This software screens all data recorded by the bat detector and extracts call files using a filter. Using the default settings for this initial screen also provides for comparability between data sets. Settings used by the filter include a max TBC (time between calls) of 5 seconds, a minimum line length of 5 milliseconds, and a smoothing factor of 50. The smoothing factor refers to whether or not adjacent pixels can be connected with a smooth line. The higher the smoothing factor, the less restrictive the filter and the more noise files and poor quality call sequences that are retained within the data set.

Following extraction of call files, each file was visually inspected for species identification and to determine that only bat calls were included in the data set. Insect activity, wind, and interference can sometimes produce Anabat files that pass through the initial filter and need to be visually inspected and removed from the data set. Call sequences are easily differentiated from other recordings, which typically form a diffuse band of dots at either a constant frequency or widely varying frequency.

Because bat activity levels are highly variable among individual nights and individual hours (Arnett *et al.* 2006, Hayes 1997), detection rates are summarized on both of these temporal scales. Hourly detection rates were summarized by hour after sunset, as recommended by Kunz *et al.* (2007). Quantitative comparisons among these temporal periods was not attempted because the high amount of variability associated with bat detection would have required much larger sample sizes (Arnett *et al.* 2006, Hayes 1997).

Bat call sequences were individually marked and categorized by species group, or “guild”, based on visual comparison to reference calls. Relatively accurate identification of bat species can be attained by visually comparing recorded call sequences of sufficient length to bat call reference libraries (O’Farrell *et al.* 1999, O’Farrell and Gannon 1999). Call sequences were classified to species whenever possible, based on criteria developed from review of reference calls collected by Chris Corben, the developer of the Anabat system, as well as other bat researchers. However, due to similarity of call signatures between several species, all classified calls have been categorized into five guilds<sup>†</sup> reflecting the bat community in the region of the Project area:

- **Unknown (UNKN)** – All call sequences with less than five calls, or poor quality sequences (those with indistinct call characteristics or background static). These sequences were further identified as either “high frequency unknown” (HFUN) for sequences with a minimum frequency above 30 to 35 kHz, or “low frequency unknown” (LFUN) for sequences with a minimum frequency below 30 to 35 kHz. For this area, HFUN most likely represents eastern red bats, tri-colored bats, and *Myotis* species. LFUN likely represents big brown, silver-haired, and hoary bats species in this area.

<sup>†</sup> Gannon *et al.* 2003 categorized bats into guilds based upon similar minimum frequency and call shape. These guilds were: Unidentified, *Myotis*, LABO-PESU and EPFU-LANO-LACI. To report the activity of the migratory hoary bat, it was placed into a separate guild.



- **Myotis (MYSP)** – All bats of the genus *Myotis*. While there are some general characteristics believed to be distinctive for the three species in this genus, these characteristics are not sufficiently consistent to be relied upon for current species identification at all times when using Anabat recordings.
- **Big brown bat/silver-haired bat (BBSH)** – Big brown and silver-haired bats. These species' call signatures commonly overlap and have therefore been included as one guild in this report.
- **Hoary bat (HB)** – Hoary bats. Calls of hoary bats can usually be distinguished from those of big brown and silver-haired bats by minimum frequency extending below 20 kHz or by calls varying widely in minimum frequency across a sequence.
- **Eastern red bat/tri-colored bat<sup>‡</sup> (RBTB)** – Eastern red, tri-colored bats, and evening bats. These three species can produce distinctive calls; however, significant overlap in the call pulse shape, frequency range, and slope can also occur between red bats and evening bats, and between red bats and tri-colored bats.

This method of guild identification represents a conservative approach to bat call identification. Because some species occasionally produce calls unique only to that species, all calls were identified to the lowest possible taxonomic level before being grouped into the listed guilds. Tables and figures in the body of this report will reflect those guilds. However, since species-specific identification did occur in some cases, each guild will also be briefly discussed with respect to potential species composition of recorded call sequences.

Once all of the call files were identified and categorized in appropriate guilds, nightly tallies of detected calls were compiled. Mean detection rates (number of recordings/detector-night) for the entire sampling period were calculated for each detector and for all detectors combined. The sunset time was subtracted from the time of recording to determine the number of hours after sunset when each file was recorded.

## 4.0 Results

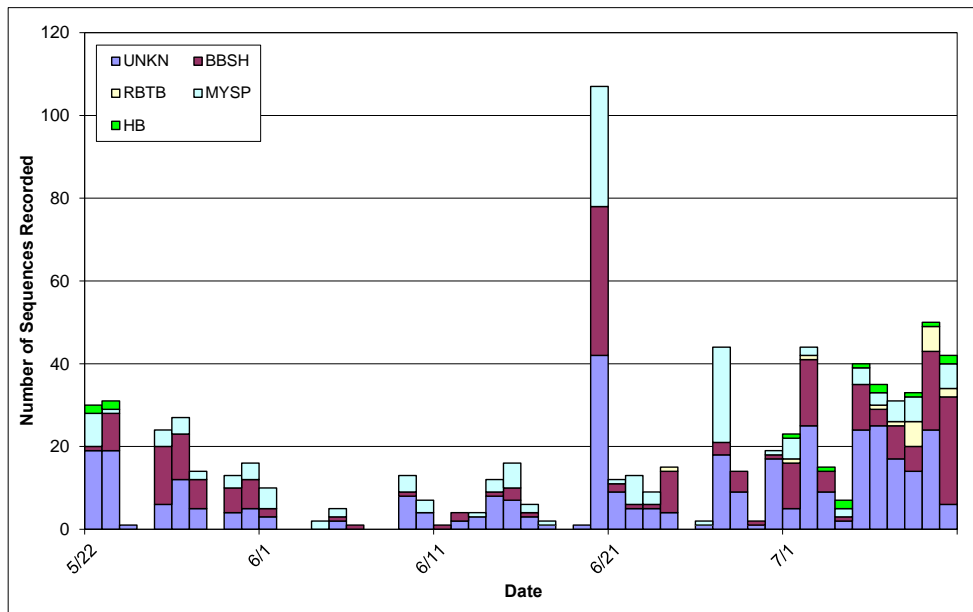
---

The primary acoustic detector operated successfully on 50 nights between May 22 and July 10, 2012. A total of 797 bat call sequences were recorded during this period (Figure 4-1). Between 0 and 107 call sequences were recorded per night, with an overall activity level of 15.9 call sequences per detector-night (C/D/N). Bats were detected during 42 out of 50 surveyed nights (84 percent). Mean nightly temperatures ranged from 10.3°C to 23.9°C during the survey

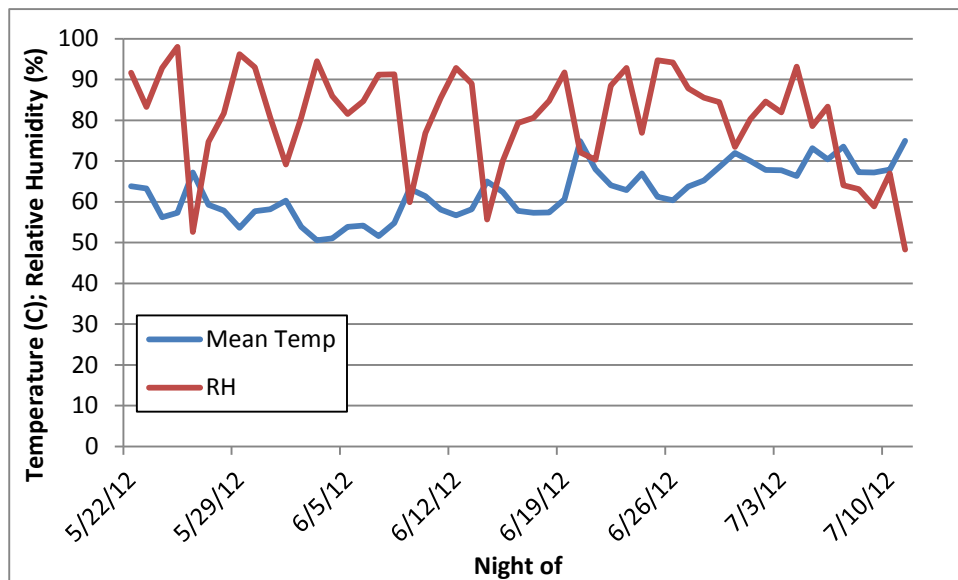
---

<sup>‡</sup> The scientific and common name of the eastern pipistrelle (*Pipistrellus subflavus*) has been changed to the tri-colored bat (*Perimyotis subflavus*).

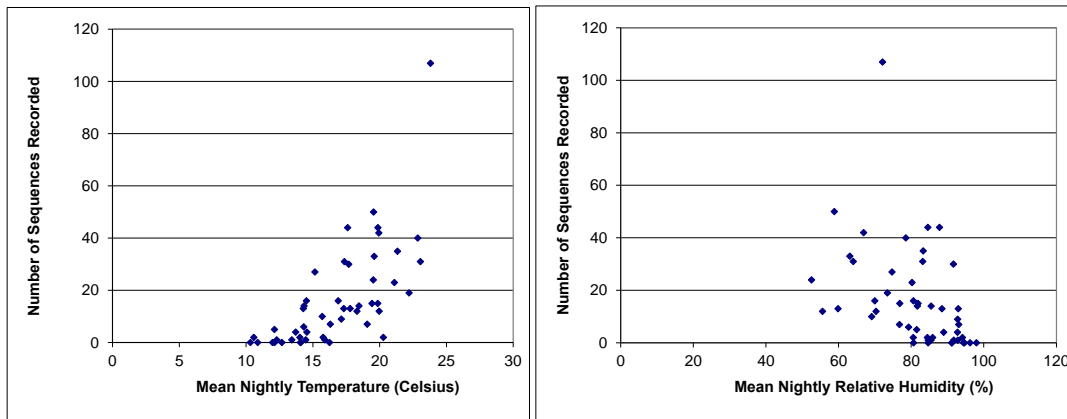
period, with mean nightly relative humidity ranging from 48.3 to 98.0 percent. Nightly bat activity levels appeared to be positively correlated with nightly mean temperature and negatively correlated with nightly mean relative humidity. Appendix A includes a table providing nightly summaries of acoustic bat activity by survey night as well as nightly mean relative humidity and temperature.



**Figure 4-1.** Acoustic bat survey results by survey night during summer 2012 surveys at Dice Head Lighthouse in Castine, Maine.

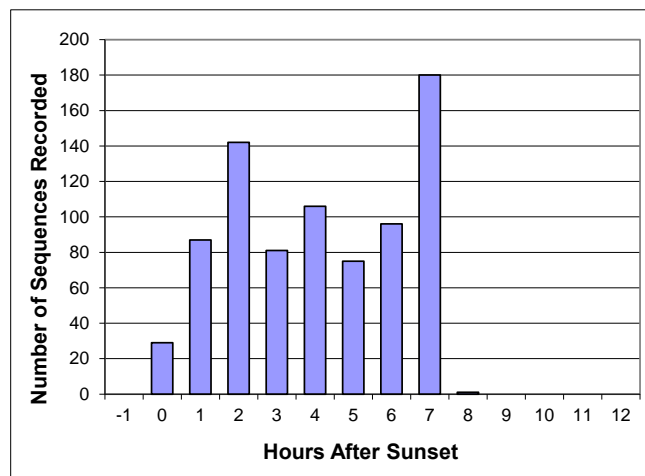


**Figure 4-2.** Mean nightly temperature and relative humidity during summer 2012 surveys at Dice Head Lighthouse in Castine, Maine.



**Figure 4-3.** Nightly bat activity levels versus temperature (left) and relative humidity (right) during summer 2012 surveys at Dice Head Lighthouse in Castine, Maine.

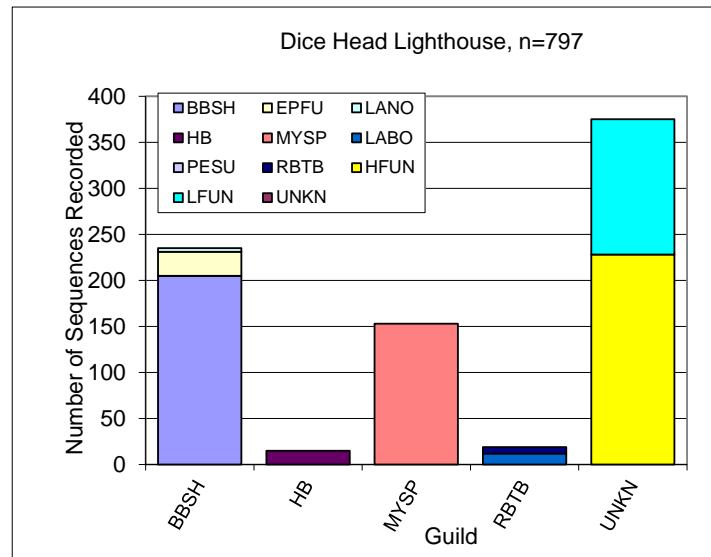
Bat calls were detected between 0:32 and 8:01 hours past sunset, with the overall highest number of calls occurring in the seventh hour past sunset (Figure 4-4). Distribution of nightly timing by hour past sunset varied considerably among survey nights, although the highest number of calls occurred during the second and seventh hours past sunset on six nights each, more than for any other hour past sunset.



**Figure 4-4.** Acoustic bat survey results by hour past sunset during summer 2012 surveys at Dice Head Lighthouse in Castine, Maine.

Of the 797 recorded call sequences, 422 (53 percent) were identified to species or guild and the remaining 375 call fragments were too short to be identified but were classified as either high frequency or low frequency “unknown” (Figure 4-5). The BBSH guild, including the big brown bat and silver-haired bat was the most frequently identified guild, followed by bats in the *Myotis* genus. Eastern red bats and hoary bats were also documented at the site. Within the BBSH guild, 26 sequences were classified as big brown bats, and 4 sequences were classified as silver-haired bats, with the remaining 205 sequences identified to guild only. Within the RBTB

guild, 12 sequences were classified as eastern red bats, zero were identified as tri-colored bats, and 7 were identified to guild only.



**Figure 4-5.** Acoustic bat survey results by guild during summer 2012 surveys at Dice Head Lighthouse in Castine, Maine.

## 5.0 Discussion

Acoustic bat surveys documented bat activity occurring throughout the summer 2012 survey period. Bats are typically resident in Maine between mid-May and early July, so activity documented at Dice Head Lighthouse likely reflects resident bats foraging on a nightly basis. Both the nightly range in activity levels and variability among survey nights are typical of this type of survey. Bats were present on most nights within the survey period, indicating consistent presence of bats in this location during the summer. Species composition suggests that *Myotis* species (little brown bat and/or northern long-eared bat) and big brown bats are the most active species in the vicinity of Dice Head Lighthouse, with occasional presence of hoary bats, eastern red bats, and silver-haired bats. Tri-colored bats did not appear to be present during the survey period.

Comparison of data from Dice Head Lighthouse to similar datasets collected at coastal locations as part of Stantec's ongoing regional offshore acoustic bat surveys indicates similar patterns of acoustic activity. Detectors positioned on Owl's Head and Schoodic Peninsula in late summer, 2009 documented highly variable nightly activity patterns with similar species composition

(Stantec, unpublished data). The average activity level at Owl's Head, Maine during 21 nights in August, 2009, was 116 C/D/N, and the average activity level during 14 nights in August, 2009 at Schoodic Peninsula, Maine was 11.6 C/D/N. Typically, *Myotis* species are common at coastal locations and less common in offshore survey locations, such as buoys, isolated rocky islands with limited foraging or roosting habitat. Whereas regional surveys have focused on the fall migratory period, limited available datasets suggest low activity levels offshore during the summer period (June and July) relative to the fall (mid-August through mid-September).

Surveys took place at Dice Head Lighthouse, a coastal location, and not in the immediate location where the turbine will actually be positioned, so documented activity levels were likely greater than what will occur at the turbine site, particularly between mid-May and mid-July when long-distance migratory species are likely less abundant and active in the region. However, surveys do indicate relatively active bat populations along the coastline, and these bats may occasionally forage over the water or cross the mouth of the Penobscot River to access nearby islands or the mainland on the opposite side of the river. The apparent peak in bat activity 7 hours past sunset on several nights may be indicative of bats returning to the mainland after offshore or nearshore foraging, although available data are insufficient to support this possibility.

Recent studies have found that bat activity patterns are influenced by weather conditions (Arnett *et al.* 2006, Arnett *et al.* 2008, Reynolds 2006). Acoustic surveys have documented a decrease in bat activity rates as wind speed increases and temperature decreases, and bat activity has been shown to correlate negatively to low nightly mean temperatures (Hayes 1997, Reynolds 2006). Multiple weather variables can individually affect bat activity, as does the interaction among variables (i.e., warm nights with low wind speeds). Although wind speed data were unavailable from the survey site, bat activity levels did appear to be higher on warmer, drier nights.

When considering the level of activity documented at the Project, it is important to acknowledge that numbers of recorded bat call sequences cannot be correlated with the number of bats in an area because acoustic detectors cannot differentiate between individuals (Hayes 2000). Thus, results of acoustic surveys must be interpreted with caution. Methods surrounding acoustic bat surveys are continually evolving, and there is currently little data aiding in the interpretation of the number of calls per detector nights. Although interpretations are limited, the surveys represent a sample of activity, activity timing, and the general species groups that occur at the survey location.

## 6.0 Literature Cited

---

- Arnett, E. B., J.P. Hayes, and M.M.P. Huso. 2006. An evaluation of the use of acoustic monitoring to predict bat fatality at a proposed wind facility in south central Pennsylvania. An annual report submitted to the Bats and Wind Energy Cooperative. Bat Conservation International. Austin, Texas, USA.
- Arnett, E.B., W.K. Brown, W.P. Erickson, J.K. Fiedler, B.L. Hamilton, T.H. Henry, A. Jain, G.D. Johnson, J. Kerns, R.R. Koford, C.P. Nicholson, T.J. O’Connell, M.D. Piorkowski, and R.D. Takersley Jr. 2008. Patterns of bat fatalities at wind energy facilities in North America. *Journal of Wildlife Management* 72:61-78.
- Hayes, J.P. 1997. Temporal variation in activity of bats and the design of echolocation monitoring studies. *Journal of Mammalogy* 78:1-524.
- DeGraaf, R.M. and M. Yamasaki. 2001. *New England Wildlife; Habitat, Natural History, and Distribution*. University Press of New England, Hanover, NH. 482p.
- Gannon, W.L., R.E. Sherwin, and S. Haywood. 2003. On the importance of articulating assumptions when conducting acoustic studies of habitat use by bats. *Wild. Soc. Bull.* 31 (1):45–61.
- Hayes, J.P. 2000. Assumptions and practical considerations in the design and interpretation of echolocation-monitoring studies. *Acta Chiropterologica* 2(2):225-236.
- Kunz, T.H., E.B. Arnett, B.M. Cooper, W.P. Erickson, R.P. Larkin, T. Mabee, M.L. Morrison, M.D. Strickland, and J.M. Szewczak. 2007. Assessing impacts of wind-energy development on nocturnally active birds and bats: A guidance document. *Journal of Wildlife Management* 71:2449-2486.
- MDDNR (Maryland Department of Natural Resources). 2012. Discover Maryland’s Bats. [http://www.dnr.state.md.us/wildlife/plants\\_wildlife/bats/index.asp](http://www.dnr.state.md.us/wildlife/plants_wildlife/bats/index.asp)
- MDNHP (Maryland Natural Heritage Program). 2010. *Rare, Threatened, and Endangered Animals of Maryland*. April 2010 ed. Maryland Department of Natural Resources, Wildlife and Heritage Service, Annapolis, Maryland.
- O’Farrell, M.J., and W.L. Gannon. 1999. A comparison of acoustic versus capture techniques for the inventory of bats. *Journal of Mammalogy* 80(1):24–30.
- O’Farrell, M.J., B.W. Miller, and W.L. Gannon. 1999. Qualitative identification of free-flying bats using the anabat detector. *Journal of Mammalogy* 80(1):11–23.

Reynolds, D.S. 2006. Monitoring the potential impacts of a wind development site on bats in the Northeast. *Journal of Wildlife Management* 70(5):1219 – 1227.

USFWS (United States Fish and Wildlife Service). 2007. Indiana Bat (*Myotis sodalis*) Draft Recovery Plan: First Revision.

---

## Appendix A

### Acoustic Bat Survey Data Tables





**Appendix A Table 1.** Summary of acoustic bat data and weather during each survey night during summer 2012 surveys at Dice Head Lighthouse, Castine, Maine

Night of	Operational?	BBSH			HB	MYSP	RBTB			UNKN			Total	Temperature (celsius)	Relative Humidity (%)
		BBSH	Big brown	Silver-haired	Hoary	MYSP	Eastern red	Tri-colored	RBTB	HFUN	LFUN	UNKN			
05/22/12	y		1		2	8				16	3		30	18	92
05/23/12	y	9			2	1				11	8		31	17	83
05/24/12	y									1			1	13	93
05/25/12	y												0	14	98
05/26/12	y	14				4				3	3		24	20	53
05/27/12	y	11				4				9	3		27	15	75
05/28/12	y	3	3	1		2				2	3		14	14	82
05/29/12	y												0	12	96
05/30/12	y	6				3				3	1		13	14	93
05/31/12	y	7				4					5		16	15	81
06/01/12	y	2				5				1	2		10	16	69
06/02/12	y												0	12	81
06/03/12	y												0	10	94
06/04/12	y					2							2	11	86
06/05/12	y			1		2				1	1		5	12	82
06/06/12	y	1											1	12	85
06/07/12	y												0	11	91
06/08/12	y												0	13	91
06/09/12	y	1				4				7	1		13	17	60
06/10/12	y					3				4			7	16	77
06/11/12	y	1											1	14	85
06/12/12	y	2								2			4	14	93
06/13/12	y					1				1	2		4	15	89
06/14/12	y	1				3				7	1		12	18	56
06/15/12	y	2	1			6				7			16	17	70
06/16/12	y	1				2				3			6	14	79
06/17/12	y					1				1			2	14	81
06/18/12	y												0	14	85
06/19/12	y									1			1	16	92
06/20/12	y	31	5			29				38	4		107	24	72
06/21/12	y	1		1		1				7	2		12	20	70
06/22/12	y	1				7				5			13	18	89
06/23/12	y	1				3				5			9	17	93
06/24/12	y	6	3	1					1	2	2		15	19	77
06/25/12	y												0	16	95
06/26/12	y					1				1			2	16	94
06/27/12	y	2	1			23				17	1		44	18	88
06/28/12	y	5								4	5		14	18	85
06/29/12	y	1								1			2	20	84
06/30/12	y	1				1				12	5		19	22	73
07/01/12	y	9	2		1	5	1			2	3		23	21	80
07/02/12	y	15	1			2	1			4	21		44	20	85
07/03/12	y	2	3		1					5	4		15	20	82
07/04/12	y	1			2	2				2			7	19	93
07/05/12	y	10	1		1	4				8	16		40	23	79
07/06/12	y	4			2	3	1			3	22		35	21	83
07/07/12	y	7	1			5			1	9	8		31	23	64
07/08/12	y	6			1	6	3		3	10	4		33	20	63
07/09/12	y	19			1		4		2	12	12		50	20	59
07/10/12	y	22	4		2	6	2			1	5		42	20	67
<b>By Species</b>		<b>205</b>	<b>26</b>	<b>4</b>	<b>15</b>	<b>153</b>	<b>12</b>	<b>0</b>	<b>7</b>	<b>228</b>	<b>147</b>	<b>0</b>	<b>797</b>		
<b>By Guild</b>		<b>235</b>			<b>15</b>	<b>153</b>	<b>19</b>			<b>375</b>			<b>Total</b>		
		<b>BBSH</b>			<b>HB</b>	<b>MYSP</b>	<b>RBTB</b>			<b>UNKN</b>					

# 2013 Interim Acoustic Bat Survey Report

Dice Head Lighthouse  
Castine, Maine

Prepared for

DeepCWind  
University of Maine  
Darling Marine Center  
193 Clark Cove Road  
Walpole, ME 04573

Prepared by

Stantec Consulting Services Inc.  
30 Park Drive  
Topsham, ME 04086



---

**Stantec**

December 2013



---

## Executive Summary

---

The DeepCWind Consortium, led by the University of Maine, has installed a prototype of a floating wind turbine in the waters of Penobscot Bay near Castine, Maine. Aligned with this effort, Stantec Consulting Services, Inc. (Stantec) conducted a second year of acoustic bat surveys from the tower of the Dice Head Lighthouse in Castine, the nearest feasible monitoring location to the site at which the test turbine is to be deployed. Survey methods replicated the 2012 acoustic monitoring efforts at this same location, and followed those used by similar assessments of bat activity conducted by Stantec in the Gulf of Maine since 2009.

An acoustic detector was deployed on the tower of the Dice Head Lighthouse on May 14, 2013, and operated on a nightly basis through the night of October 11, 2013. A total of 1,326 bat call sequences were recorded during this 151-night period. Between 0 and 103 call sequences were recorded per night, with an overall activity level of 8.8 call sequences per detector-night. Bats were detected during 126 out of the 151 surveyed nights (83%). Of the 1,326 recorded call sequences, 829 (63%) were identified to species or guild and the remaining 497 call fragments were either too short, or lacked sufficient characteristic detail to be identified to species, and were classified as either high frequency or low frequency “unknown.” The BBSH guild, including the big brown bat (*Eptesicus fuscus*) and silver-haired bat (*Lasionycteris noctivagans*) was the most frequently identified guild, followed by a similar level of detected activity from both the *Myotis* and RBTB (including the eastern red bat [*Lasiurus borealis*] and tricolored bat [*Perimyotis subflavus*]) guilds.



## Table of Contents

<b>EXECUTIVE SUMMARY .....</b>	<b>E.1</b>
<b>1.0 INTRODUCTION.....</b>	<b>1</b>
<b>2.0 DATA COLLECTION METHODS .....</b>	<b>3</b>
<b>3.0 DATA ANALYSIS METHODS.....</b>	<b>5</b>
<b>4.0 RESULTS .....</b>	<b>7</b>
<b>5.0 DISCUSSION.....</b>	<b>10</b>
<b>6.0 LITERATURE CITED.....</b>	<b>12</b>

### List of Photos

Photo 2-1. Dice Head Lighthouse, Castine, ME .....	4
Photo 2-2. Paired acoustic detector deployment. ....	4

### List of Figures

Figure 1-1. Project Location Map. ....	2
Figure 4-1. Acoustic bat survey results by survey night and mean nightly temperature during May–October 2013 surveys at Dice Head Lighthouse in Castine, Maine.....	7
Figure 4-2. Acoustic bat survey results by survey night and relative humidity during May–October 2013 surveys at Dice Head Lighthouse in Castine, Maine.....	8
Figure 4-3. Nightly bat activity levels versus temperature and relative humidity during May–October 2013 surveys at Dice Head Lighthouse in Castine, Maine.....	8
Figure 4-4. Acoustic bat survey results by hour past sunset during May–October 2013 surveys at Dice Head Lighthouse in Castine, Maine.....	8

### List of Appendices

Appendix A. Acoustic Bat Survey Data Tables	
---	--

PN195600798\*

---

\* This report was prepared by Stantec Consulting Services Inc. for DeepCWind. The material in it reflects Stantec's judgment in light of the information available to it at the time of preparation. Any use which a third party makes of this report, or any reliance on or decisions made based on it, are the responsibility of such third parties. Stantec accepts no responsibility for damages, if any suffered, by any third party as a result of decisions made or actions based on this report.

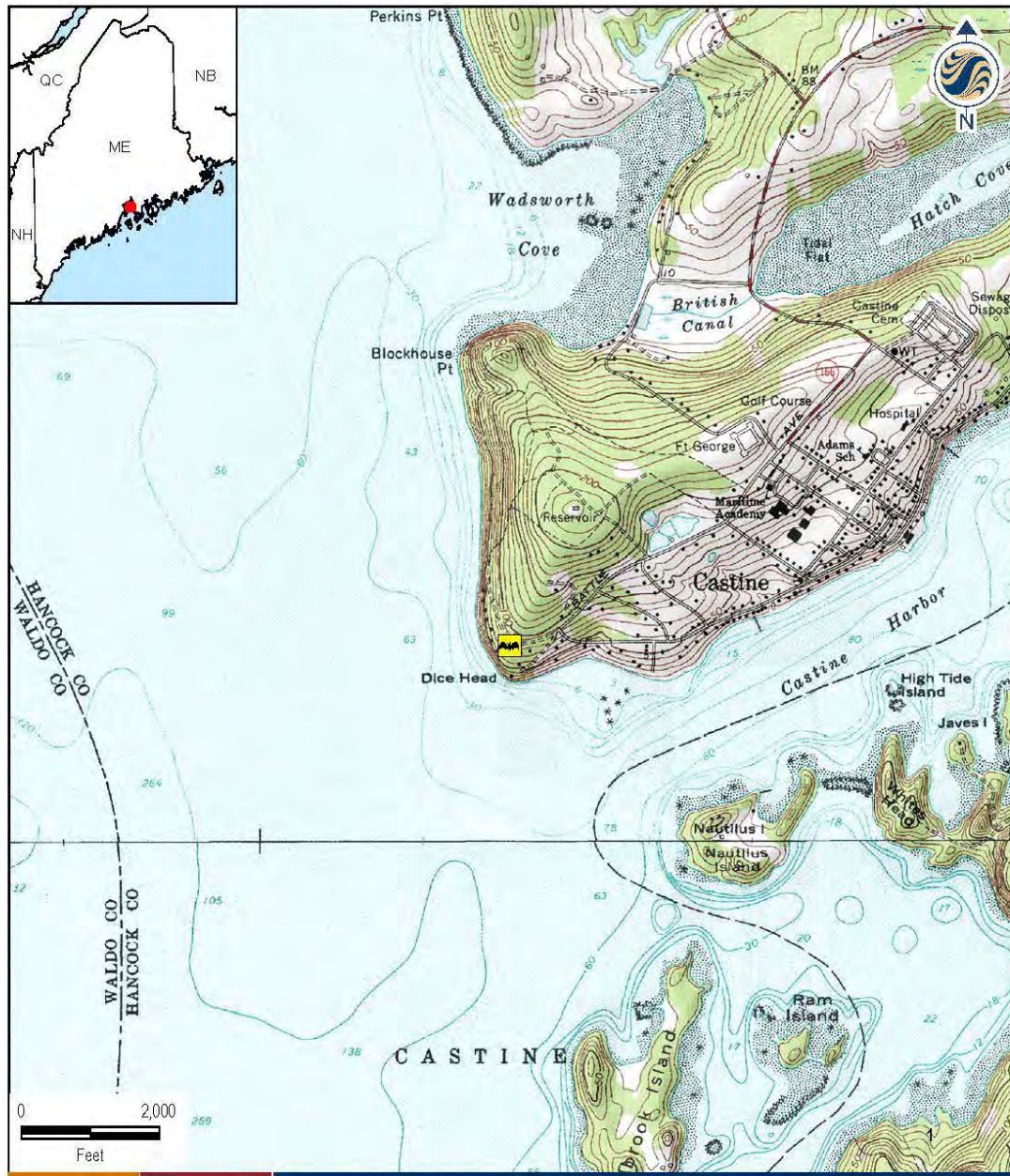
## 1.0 Introduction

---

The DeepCWind Consortium, led by the University of Maine, has installed a prototype of a floating wind turbine in the waters of Penobscot Bay near Castine, Maine. Stantec Consulting Services Inc. (Stantec) conducted a second year of acoustic bat surveys to document seasonal bat activity in the general vicinity of the turbine deployment area. Surveys were conducted at the Dice Head Lighthouse in Castine as it provided the nearest accessible survey location where acoustic equipment could be safely deployed (Figure 1). Bat detectors operated at the lighthouse from mid-May through mid-October, 2013. Survey methods replicated the 2012 acoustic monitoring efforts at this same location as well as those employed by Stantec at 18 shoreline/offshore locations distributed throughout the Gulf of Maine since 2009.

Bats use high frequency echolocation to maneuver through the landscape during migration or in search of food and water. Electronic equipment can be used to record these calls, which are above the frequency range of human hearing. Acoustic sampling of bat activity has become a standard pre-construction survey for proposed wind-energy development (Kunz *et al.* 2007). This type of sampling allows for long-term passive monitoring in a variety of habitat types and locations. Although acoustic surveys are associated with several major assumptions (Hayes 2000) and results cannot be used to determine the number of bats inhabiting an area, acoustic surveys can provide insight into patterns in bat activity, species composition, and use of an area.

Eight species of bats are known to occur in Maine, based upon their normal geographical range. These are the little brown bat (*Myotis lucifugus*), northern long-eared bat, (*M. septentrionalis*), eastern small-footed bat (*M. leibii*), silver-haired bat (*Lasionycteris noctivagans*), tri-colored bat (*Perimyotis subflavus*), big brown bat (*Eptesicus fuscus*), eastern red bat (*Lasiurus borealis*), and hoary bat (*L. cinereus*) (DeGraaf and Yamasaki 2001). All eight species could potentially occur in the mid-coast survey region, and fall within the recordable range of acoustic bat detectors.



**Stantec Consulting Services Inc.**  
 30 Park Drive  
 Topsham, ME USA  
 04086  
 Phone (207) 729-1199  
 Fax: (207) 729-2715  
 www.stantec.com

**Legend**

Acoustic Bat Survey Location

**Client/Project**  
 University of Maine  
 Dice Head Bat Survey  
 Castine, Maine

**Figure No.**  
 1

**Title**  
**Project Location Map**  
 August 2, 2012

00798\_001\_Locus.mxd

195600798

Figure 1-1. Project Location Map.

## 2.0 Data Collection Methods

---

One SD1-based acoustic detector system consisting of a primary and backup detector was deployed on the platform of the Dice Head Lighthouse tower at a height of approximately 14 meters (m) above ground level. The lighthouse is located approximately 85 m from the high tide mark and is surrounded by habitat consisting of a mix of deciduous and coniferous trees, developed residential lawns, and light residential development (Photo 2-1).

Anabat SD1 detectors (Titley Electronics Pty Ltd.) are commonly used for this type of data collection because of their ability to be deployed for long periods of time, and their ability to detect a broad frequency range, allowing detection of all species of bats that could occur in Maine. Anabat detectors are frequency division detectors, dividing the frequency of echolocation sounds made by bats by a factor of 16, and then recording these sounds onto removable compact flash cards for subsequent analysis. Detectors were programmed to begin monitoring at 18:00 hours each night, and end monitoring at 08:00 hours each morning. The audio sensitivity setting of each Anabat system was set between 6 and 7 (on a scale of 1 to 10) to maximize sensitivity while limiting ambient background noise and interference. Prior to deployment, the sensitivity of each detector was tested using an ultrasonic Bat Chirp (Reno, NV) to determine that the detectors would be able to detect bats up to a distance of at least 10 mft.

The acoustic system consisted of 2 SD1 detectors, powered by a single 12-volt battery charged by 2 10-watt solar panels. The SD1 detectors were deployed in separate waterproof housings with a 90 degree PVC elbow used to direct bat calls into the microphone while protecting the units from the weather (Photo 2-2). This standardized system has successfully been used at the majority of long-term offshore acoustic bat surveys conducted by Stantec. Temperature and relative humidity were measured at the survey site using a datalogger set to record at 15-minute intervals (Onset, HOBO model Pro V2 U23-001). That data was not able to be retrieved during a recent (October 12, 2013) data download but will be collected at a later date. An identical HOBO data collector, however, was deployed during a similar period at a lighthouse approximately 60 miles southeast of Castine. Data collected from that HOBO unit provides the basis of weather data for this interim report.

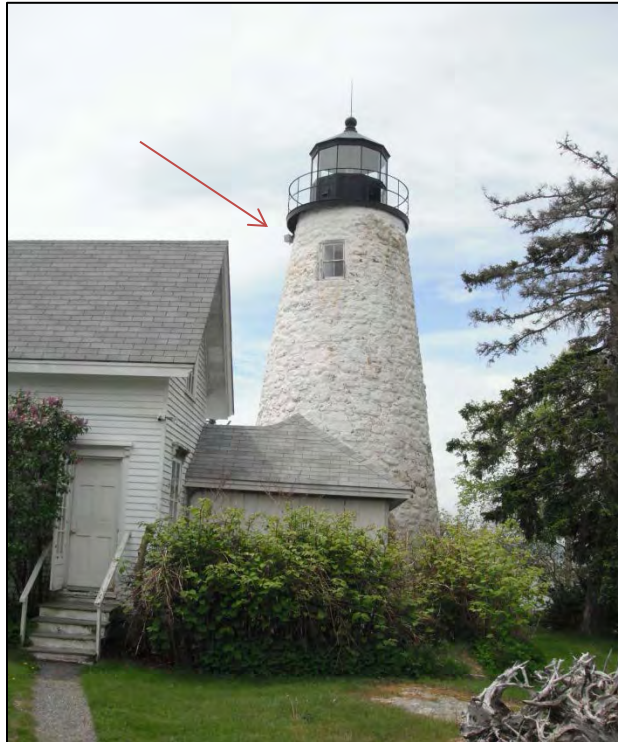


Photo 2-1. Dice Head Lighthouse, Castine, ME. Red arrow depicts location of paired detectors.

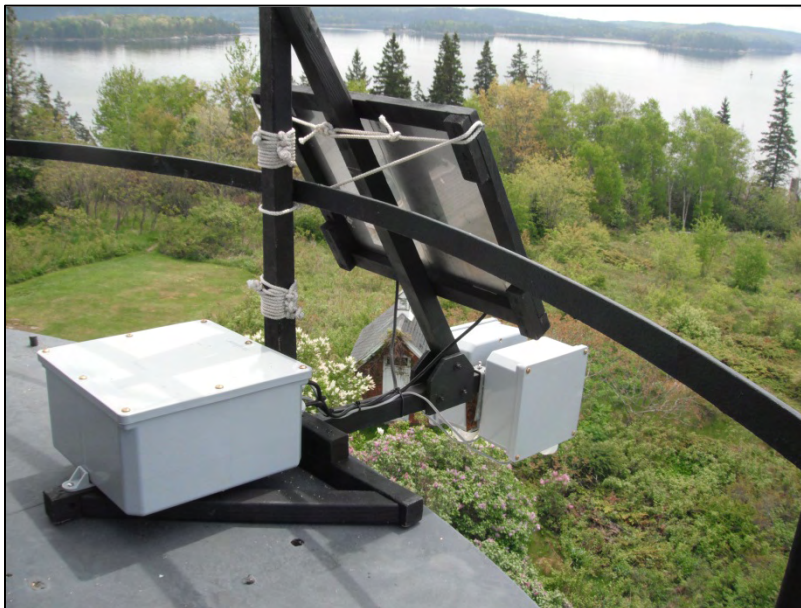


Photo 2-2. Paired acoustic detector deployment. *Note:* Unit is lashed to tower railing to avoid potential damages in accordance with Maine Historical Preservation Commission recommendations.





### 3.0 Data analysis methods

---

Ultrasound recordings of bat echolocation may be broken into recordings of a single bat call or recordings of bat call sequences. A call is a single pulse of sound produced by a bat, while a call sequence is a combination of 2 or more pulses recorded in an Anabat file. Recordings containing less than 2 calls were eliminated from analysis as has been done in similar studies (Arnett *et al.* 2006). Call sequences typically include a series of calls characteristic of normal flight or prey location (“search phase”) and capture periods (feeding “buzzes”).

Potential call files were extracted from data files using CFCread<sup>®</sup> software. The default settings for CFCread<sup>®</sup> were used during the extraction and are recommended for calls that are characteristic of bats in the Northeast. This software screens all data recorded by the detector and extracts bat call files using a filter. Settings used by the filter include a max TBC (time between calls) of 5 seconds, a minimum line length of 5 milliseconds, and a smoothing factor of 50. The smoothing factor refers to whether or not adjacent pixels can be connected with a smooth line. The higher the smoothing factor, the less restrictive the filter and the more noise files and poor quality call sequences that are retained within the data set.

Following the extraction of call files, data was processed with Bat Call ID (BCID East; version 2.6a), an automated acoustic analysis program which is regularly evaluated by the US Fish and Wildlife Service (USFWS). BCID extracts parameters from acoustic recordings and compares them with an extensive library of reference calls. BCID allows the user to apply a regional bat species filter when processing acoustic data and includes a series of evolving filters for states from the eastern US. The Maine species filter is capable of identifying high quality calls from all bat species found in Maine. The recommended default program settings were applied to the data, and included a minimum number of call pulse criteria of 5 pulses for species-level identification.

BCID’s automated analysis program has the ability to quickly process large acoustic datasets, identifying high quality bat calls. However, lower quality call recordings are frequently not recognized by the program. BCID also occasionally misidentifies recordings of insect activity, or wind, as bat calls. Consequently, all recorded call files are visually inspected during an internal Quality Assurance Quality Control process to account for low quality calls potentially missed during the automated analysis phase and to ensure the removal of any misidentified noise.

Because bat activity levels are highly variable among individual nights and individual hours (Arnett *et al.* 2006, Hayes 1997), detection rates are summarized on both of these temporal scales. Hourly detection rates were summarized by hour after sunset, as recommended by Kunz *et al.* (2007). Quantitative comparisons among these temporal periods was not attempted because the high amount of variability associated with bat detection would have required much larger sample sizes (Arnett *et al.* 2006, Hayes 1997).



Bat call were individually marked and categorized by species group, or “guild,” based on BCID results and visual comparison to reference calls. Call sequences identified by hand were classified to species whenever possible, based on criteria developed from review of reference calls collected by Chris Corben, the developer of the Anabat system, as well as other bat researchers. Relatively accurate species identification can be made by visually comparing recorded call sequences of sufficient length to bat call reference libraries (O’Farrell *et al.* 1999, O’Farrell and Gannon 1999). However, due to similarity of call signatures between several species, all classified calls have been categorized into 5 guilds<sup>†</sup> reflecting the bat community in the region of the Project area:

- **Unknown (UNKN)** – All call sequences with less than 5 calls, or poor quality sequences (those with indistinct call characteristics or background static). These sequences were further identified as either “high frequency unknown” (HFUN) for sequences with a minimum frequency above 30– 35 kHz, or “low frequency unknown” (LFUN) for sequences with a minimum frequency below 30– 35 kHz. For this area, HFUN most likely represents eastern red bats, tri-colored bats, and *Myotis* species. LFUN likely represents big brown, silver-haired, and hoary bats species in this area.
- **Myotis (MYSP)** – All bats of the genus *Myotis*. While there are some general characteristics believed to be distinctive for the 3 species in this genus (little brown, northern long-eared, and eastern small-footed bats), these characteristics are not sufficiently consistent to be relied upon for current species identification at all times when using Anabat recordings.
- **Big brown bat/silver-haired bat (BBSH)** – Big brown (EPFU) and silver-haired (LANO) bats. These species’ call signatures commonly overlap and have therefore been included as one guild in this report.
- **Hoary bat (HB)** – Hoary bats. Calls of hoary bats can usually be distinguished from those of big brown and silver-haired bats by minimum frequency extending below 20 kHz or by calls varying widely in minimum frequency across a sequence.
- **Eastern red bat/tri-colored bat<sup>‡</sup> (RBTB)** – Eastern red (LABU) and tri-colored (PESU). These species can produce distinctive calls; however, significant overlap in the call pulse shape, frequency range, and slope can also occur between red bats and tri-colored bats.

This method of guild-level identification represents a conservative approach to bat data analysis. Because some species occasionally produce calls unique only to that species, all calls were identified to the lowest possible taxonomic level before being grouped into the listed

---

<sup>†</sup> Gannon *et al.* 2003 categorized bats into guilds based upon similar minimum frequency and call shape. These guilds were: Unidentified, *Myotis*, LABO-PESU and EPFU-LANO-LACI. To report the activity of the migratory hoary bat, it was placed into a separate guild.

<sup>‡</sup> The scientific and common name of the eastern pipistrelle (*Pipistrellus subflavus*) has been changed to the tri-colored bat (*Perimyotis subflavus*).

guilds. Tables and figures in the body of this report will reflect those guilds. However, since both the BCID and by-hand analysis methods output species-specific identification of high quality calls, species level composition of bat calls will also be discussed.

Once all of the call files were identified and categorized in appropriate guilds, nightly tallies of detected calls were compiled, and mean detection rates (number of recordings/detector-night) were calculated for the entire sampling period. Additionally, the sunset time was subtracted from the time of recording to determine the number of hours after sunset when each file was recorded.

## 4.0 Results

The primary acoustic detector operated successfully on 151 nights between 14 May and 11 October 2013. A total of 1,326 bat call sequences were recorded during this period (Figure 4-1). Between 0 and 103 call sequences were recorded per detector-night, with an overall average nightly activity level of 8.8 call sequences per detector-night (C/D/N). Bats were detected during 126 out of 151 surveyed nights (83%). Mean nightly temperatures ranged from 8.4°C (48°F) to 23.7°C (78°F) during the survey period, with mean nightly relative humidity ranging from 34.5% to 99.5% (Figure 4-1 and 4-2). Nightly bat activity levels appeared to be positively correlated with nightly mean temperature and negatively correlated with nightly mean relative humidity (Figure 4-3). Appendix A includes a table providing nightly summaries of acoustic bat activity by survey night as well as nightly mean temperature and relative humidity.

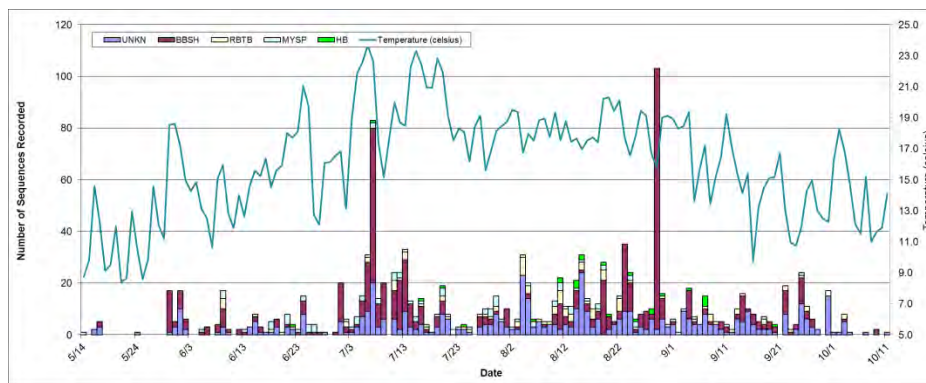


Figure 4-1. Number of recorded calls by species/guild by survey night and mean nightly temperature.

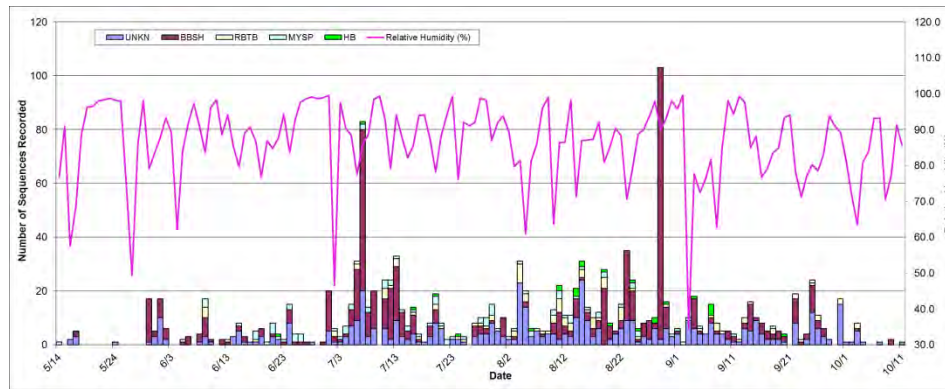


Figure 4-2. Number of recorded calls (sequences) by species/guild by survey night and relative humidity.

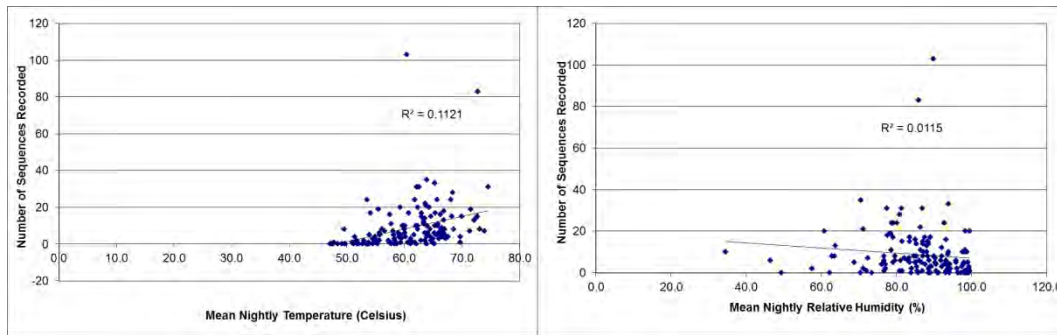


Figure 4-3. Number of recorded calls versus temperature (left) and relative humidity (right).

Distribution of nightly timing by hour past sunset varied considerably among survey nights, although the highest number of calls peaked during the second hour past sunset then declined until 11 hours past sunset (Figure 4-4).

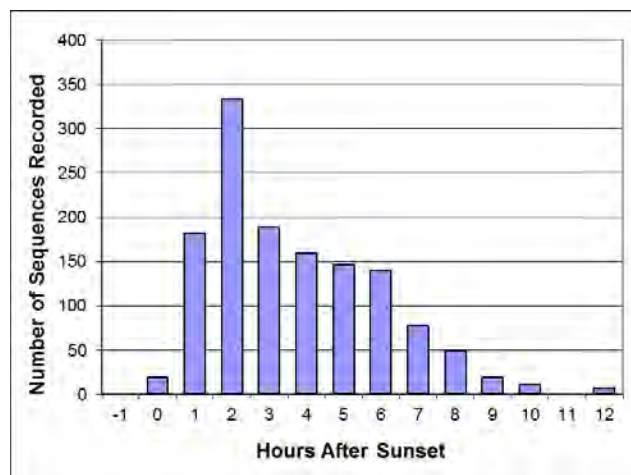


Figure 4-4. Number of recorded calls by hour past sunset.

Of the 1,326 recorded call sequences, 829 (63%) were identified to species or guild. The remaining 497 call fragments were either too short, or lacked sufficient characteristic to be identified and were classified as either high frequency or low frequency “unknown” (Figure 4-5). The BBSH guild, including the big brown bat and silver-haired bat was the most frequently identified guild, followed by a similar level of detected activity from both the *Myotis* and RBTB guilds. Hoary bats were also documented at the site. Within the BBSH guild, 317 sequences (53%) were classified as big brown bats, and 134 sequences (22%) were classified as silver-haired bats, with the remaining 149 sequences (25%) identified to guild only. Twenty-six hoary bats were identified. All 3 *Myotis* species known to occur in Maine were recorded, and included 36 little brown bats (35%), 9 eastern small-footed bats (9%), and 2 northern long-eared bats (2%). A total of 55 calls (54%) were identified only to the *Myotis* guild level. Within the RBTB guild, 75 sequences were classified as eastern red bats (74%) and 3 were identified as tri-colored bats (3%), leaving 23 calls identified to guild only (23%).

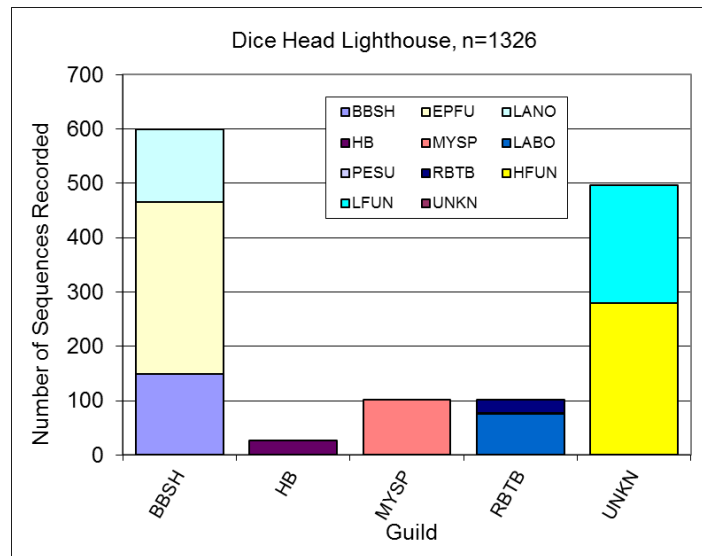


Figure 4-5. Number of recorded calls by guild.

## 5.0 Discussion

---

Bat fatality rates at terrestrial windpower sites are typically highest during the fall migratory period. The 2012 surveys conducted at the Dice Head lighthouse only documented bat activity during the summer residency period, from May to mid-July. In order to measure activity during the more vulnerable fall migratory period, the 2013 acoustic survey period was extended into mid-October. Similar to the 2012 data, bats in 2013 were found to be present on most nights from May–July; this activity likely represents the local foraging of resident bats. Both the nightly range in activity levels and variability among survey nights are typical of this type of survey. A comparison of monthly detection rates suggests that *Myotis* species and big brown bats are most active during the months of June and July, followed by declining monthly detection rates from August to mid-October. Conversely, the migratory tree bats, including the hoary bat, red bat, and silver-haired bats had relatively low monthly detection rates from May–July, but recorded the highest monthly detection rate in August. The largest night of bat activity was recorded on 29 August, and was well above the overall nightly average call rate of 8.8 C/D/N. Eighty-five of the 103 calls recorded on 29 August were identified as big brown bat calls, and 84 of those big brown calls were recorded within 1 hour of sunset. This large pulse of activity is most likely a bout of foraging driven by possibly ideal conditions.

Comparisons of acoustic data from Dice Head Lighthouse to similar datasets collected by Stantec at other regional coastal locations reveal a pattern of similar trends. Detectors positioned on Owl’s Head and Schoodic Peninsula in late summer 2009 documented highly variable nightly activity patterns with similar species composition (Peterson *in press*). The average activity level at Owl’s Head, Maine during 21 nights in August 2009, was 116 C/D/N, and the average activity level during 14 nights in August 2009 at Schoodic Peninsula, Maine was 11.6 C/D/N. Typically, *Myotis* species are common at coastal locations and less common in more distant offshore survey locations, such as buoys and isolated rocky islands with limited foraging or roosting habitat. Whereas regional surveys have focused on the fall migratory period, limited available datasets suggest comparatively lower activity levels offshore during the summer period (June and July) relative to the fall (mid-August through mid-September).

We note surveys occurred at Dice Head Lighthouse, a coastal location, and not at the location where the prototype turbine is currently positioned. Consequently it is likely the documented activity levels are greater than what occur at the open water turbine site, particularly between mid-May and mid-July when long-distance migratory species are less abundant and active in the region. However, similar surveys have indicated relatively active bat populations along the coastline, and these bats likely forage over the water or cross the mouth of the Penobscot River to access nearby islands or the mainland on the opposite side of the river.

Bat activity typically peaked the second hour after sunset on a nightly basis during the May–October survey period. However, post sunset detection rates varied considerably when viewed on an individual monthly basis. During the month of October, the highest activity rate was



recorded during the sixth hour after sunset. Although available data are insufficient to support any conclusion, this activity may be indicative of bats returning to the mainland after offshore or nearshore migration activity.

Recent studies have found that bat activity patterns are influenced by weather conditions (Arnett *et al.* 2006, Arnett *et al.* 2008, Reynolds 2006). Acoustic surveys have documented a decrease in bat activity rates as wind speed increases and temperature decreases, and bat activity has been shown to correlate negatively to low nightly mean temperatures (Hayes 1997, Reynolds 2006). Multiple weather variables can individually affect bat activity, as does the interaction among variables (i.e., warm nights with low wind speeds). Although weather data was collected 60 miles south of Castine, and wind speed data were unavailable from the survey site, bat activity levels did appear to be higher on warmer, drier nights.

When considering the level of activity documented at the Dice Head lighthouse, it is important to acknowledge that numbers of recorded call sequences cannot be accurately correlated with the number of individual bats in an area because acoustic detectors cannot differentiate between individuals (Hayes 2000). Thus, results of acoustic surveys must be interpreted with caution. Methods surrounding acoustic surveys are continually evolving, and there is currently little data aiding in the interpretation of the number of calls per detector nights. Although interpretations are limited, the surveys represent a sample of activity, activity timing, and the general species groups that occur at the survey location.

## 6.0 Literature Cited

---

- Arnett, E. B., J.P. Hayes, and M.M.P. Huso. 2006. An evaluation of the use of acoustic monitoring to predict bat fatality at a proposed wind facility in south central Pennsylvania. An annual report submitted to the Bats and Wind Energy Cooperative. Bat Conservation International. Austin, Texas, USA.
- Arnett, E.B., W.K. Brown, W.P. Erickson, J.K. Fiedler, B.L. Hamilton, T.H. Henry, A. Jain, G.D. Johnson, J. Kerns, R.R. Koford, C.P. Nicholson, T.J. O'Connell, M.D. Piorkowski, and R.D. Takersley Jr. 2008. Patterns of bat fatalities at wind energy facilities in North America. *Journal of Wildlife Management* 72:61-78.
- Hayes, J.P. 1997. Temporal variation in activity of bats and the design of echolocation monitoring studies. *Journal of Mammalogy* 78:1-524.
- DeGraaf, R.M. and M. Yamasaki. 2001. *New England Wildlife; Habitat, Natural History, and Distribution*. University Press of New England, Hanover, NH. 482p.
- Gannon, W.L., R.E. Sherwin, and S. Haywood. 2003. On the importance of articulating assumptions when conducting acoustic studies of habitat use by bats. *Wild. Soc. Bull.* 31 (1):45–61.
- Hayes, J.P. 2000. Assumptions and practical considerations in the design and interpretation of echolocation-monitoring studies. *Acta Chiropterologica* 2(2):225-236.
- Kunz, T.H., E.B. Arnett, B.M. Cooper, W.P. Erickson, R.P. Larkin, T. Mabee, M.L. Morrison, M.D. Strickland, and J.M. Szewczak. 2007. Assessing impacts of wind-energy development on nocturnally active birds and bats: A guidance document. *Journal of Wildlife Management* 71:2449-2486.
- O'Farrell, M.J., and W.L. Gannon. 1999. A comparison of acoustic versus capture techniques for the inventory of bats. *Journal of Mammalogy* 80(1):24–30.
- O'Farrell, M.J., B.W. Miller, and W.L. Gannon. 1999. Qualitative identification of free-flying bats using the anabat detector. *Journal of Mammalogy* 80(1):11–23.
- Peterson, T.S., S.K. Pelletier, S.A. Boyden, and K.S. Watrous. *In Press*. Offshore acoustic monitoring of bats in the Gulf of Maine. *Northeastern Naturalist*.
- Reynolds, D.S. 2006. Monitoring the potential impacts of a wind development site on bats in the Northeast. *Journal of Wildlife Management* 70(5):1219 – 1227.





---

## Appendix A

### Acoustic Bat Survey Data Tables



**Appendix A Table 1. Summary of acoustic bat data and weather during each survey night at the Dice Head Lighthouse detector – Summer, 2013**

Night of	Operational?	BBSH		HB		MYSP				RBTB			UNKN			Total	Temperature (celcius)	Relative Humidity (%)
		BBSH	Big brown	Silver-haired	Hoary	MYSP	MYLE	MYLU	MYSE	Eastern red	Tri-colored	RBTB	HFUN	LFUN	UNKN			
05/14/13	1															1	47.7	76.8
05/15/13	1															0	49.7	90.9
05/16/13	1												1	1		2	58.3	57.5
05/17/13	1	1	1										1	2		5	53.9	68.7
05/18/13	1															0	48.4	88.6
05/19/13	1															0	49.1	96.3
05/20/13	1															0	53.6	96.3
05/21/13	1															0	47.1	98.1
05/22/13	1															0	47.6	98.2
05/23/13	1															0	55.3	98.8
05/24/13	1												1			1	50.9	98.1
05/25/13	1															0	47.5	97.9
05/26/13	1															0	49.7	73.5
05/27/13	1															0	58.2	49.4
05/28/13	1															0	53.7	85.8
05/29/13	1															0	52.1	98.2
05/30/13	1	6	5	5										1		17	65.4	79.1
05/31/13	1		1	1									1	2		5	65.5	83.5
06/01/13	1	1	6										4	6		17	63.0	87.5
06/02/13	1	1	2	1									1	1		6	58.9	93.3
06/03/13	1															0	57.7	89.1
06/04/13	1															0	58.7	62.2
06/05/13	1		1					1								2	56.6	84.0
06/06/13	1	2	1													3	54.5	92.1
06/07/13	1															0	51.1	97.2
06/08/13	1	1	1	1										1		4	59.1	90.6
06/09/13	1	1	6			1	1	1		4			3			17	60.7	83.5
06/10/13	1		1													2	55.1	96.2
06/11/13	1													1		0	53.4	98.2
06/12/13	1		2													2	57.2	88.6
06/13/13	1		1			1										2	54.7	94.1
06/14/13	1												2	1		3	58.3	85.4
06/15/13	1	1	1					1					2	3		8	60.0	79.6
06/16/13	1		1	1									1			3	59.4	88.9
06/17/13	1												1			1	61.4	90.6
06/18/13	1									1						5	58.1	86.7
06/19/13	1	1	2										3			6	60.1	76.8
06/20/13	1									1						1	60.6	86.9
06/21/13	1		1			2		2					2	1		8	64.4	84.7
06/22/13	1				1		1						1	1		4	63.9	87.7
06/23/13	1		1			1										2	64.6	94.4
06/24/13	1	1	4			1		1					1	7		15	69.9	83.5
06/25/13	1			1		1		1	1							4	67.5	92.8
06/26/13	1		1			2		1								4	54.9	97.7
06/27/13	1	1														1	53.8	98.6
06/28/13	1													1		1	61.0	99.1
06/29/13	1															0	61.1	98.6
06/30/13	1	1														1	61.8	98.9
07/01/13	1	1	14										4	1		20	62.3	99.5
07/02/13	1		1	1						2			1			6	55.6	46.5
07/03/13	1		1											1		3	66.0	97.4
07/04/13	1	1				1		2					2	1		7	71.4	90.4
07/05/13	1	3	2	1		1	1						2	5		15	72.6	88.5
07/06/13	1	9	8	2				1		2			1	8		31	74.6	77.4
07/07/13	1	19	38	3	1	1			1				8	12		83	72.7	85.9
07/08/13	1	2	7			1		1					2	1		14	63.2	88.6
07/09/13	1	3	11											6		20	59.3	98.4
07/10/13	1															0	63.8	99.3
07/11/13	1	3	7	1		2	1			3			1	3	3	24	68.0	92.8
07/12/13	1	4	15				1	1					2			24	65.6	79.1
07/13/13	1	8	11	1		1				2			1	3	6	33	65.3	93.9
07/14/13	1	2	6	1				1					2	1		13	72.1	88.0
07/15/13	1	2	1			1		1					2			7	73.9	82.2
07/16/13	1	1	6		1			1		1			1	3		14	72.4	85.3
07/17/13	1		1			1				1						4	69.7	93.9
07/18/13	1															1	69.7	94.0
07/19/13	1	1	2	1						1			2	1		8	73.1	87.0
07/20/13	1		5		1	2		1			1		7	1		19	71.5	78.2
07/21/13	1									1			3	3		8	66.4	88.3
07/22/13	1							2								2	63.5	94.2
07/23/13	1					1							2			3	64.9	99.2
07/24/13	1				1					1			2			4	64.5	76.1
07/25/13	1					1				1			1			3	61.1	92.1
07/26/13	1															0	65.2	91.0
07/27/13	1	1	1	2						1			2	1		8	66.4	92.1
07/28/13	1	1	2			2				1			2	2		10	60.1	98.7
07/29/13	1		2					3		1			3	1		10	62.3	98.2
07/30/13	1	1				3		1		2			7	1		15	64.6	87.1
07/31/13	1					1							4	1		6	65.2	91.9
08/01/13	1	2	5										1	2		10	65.8	93.8
08/02/13	1									1			2			3	67.1	89.3
08/03/13	1		1					1		2			2			6	66.8	79.6
08/04/13	1									4			3	23		31	62.2	81.4
08/05/13	1		2					1		2			1	12	2	20	64.3	60.9
08/06/13	1				1	2							3			6	63.5	81.1
08/07/13	1									1			5			6	65.9	86.1
08/08/13	1		1							1			2	1		5	66.1	95.9
08/09/13	1									1			3	1		5	64.0	99.0
08/10/13	1	2	2							3			4			13	66.8	63.7
08/11/13	1	7	3		2	2		1		3		2	1	1		22	63.6	86.4
08/12/13	1	3								3			2	2		11	65.8	86.4
08/13/13	1	1	1			2		1		3			3			11	63.4	98.3
08/14/13	1	3	4		3	1							6	4		21	63.8	71.2
08/15/13	1		1		2			1		2			1	4	20	31	62.5	86.9
08/16/13	1	2		1				1		1			2	7		14	63.6	87.1
08/17/13	1	1	1	1						2		1	1	2		10	63.9	87.2
08/18/13	1	1	1	1		1				1			3	3		12	63.4	92.1
08/19/13	1	6	5	10	1	2				4						28	68.4	80.9
08/20/13	1	2	2	1	1											8	68.6	85.3
08/21/13	1	1											1	3		5	67.0	90.4
08/22/13	1		1	2						4		1	5	1		15	68.2	88.3
08/23/13	1	3	2	21									3	6		35	63.9	70.6
08/24/13	1	1		10	1	1		1				1		9		24	61.8	78.8
08/25/13	1		1	1	1	1				1			1	1		6	64.0	88.6
08/26/13	1	3	1	1									1	2		8	67.0	90.0
08/27/13	1	2	5										1	1		9	66.5	93.7
08/28/13	1	1		1	2								4	2		10	62.0	97.8
08/29/13	1	12	85	4														

## **2014 Acoustic Bat Survey Report**

Offshore VoltturnUS Prototype  
Wind Turbine, Castine, Maine



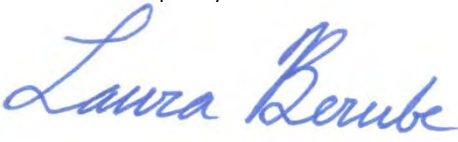
Prepared for:  
DeepCWind  
University of Maine  
Darling Marine Center  
193 Clark Cove Road  
Walpole, ME 04573

Prepared by:  
Stantec Consulting Services Inc.  
30 Park Drive  
Topsham, ME 04086

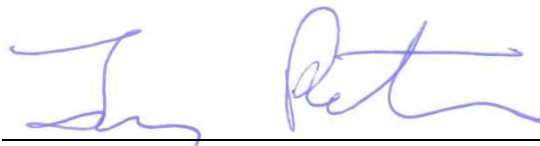
June 5, 2015

## Sign-off Sheet

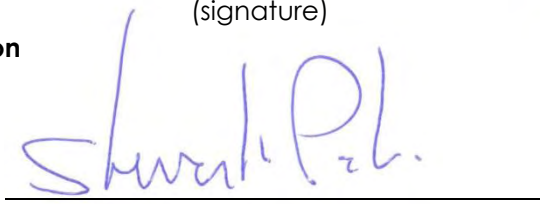
This document entitled 2014 Acoustic Bat Survey Report was prepared by Stantec Consulting Services Inc. ("Stantec") for the account of DeepCWind (the "Client"). The material in it reflects Stantec's professional judgment in light of the scope, schedule and other limitations stated in the document and in the contract between Stantec and the Client. The opinions in the document are based on conditions and information existing at the time the document was published and do not take into account any subsequent changes. In preparing the document, Stantec did not verify information supplied to it by others. Any use which a third party makes of this document is the responsibility of such third party.

Prepared by   
(signature)

**Laura Berube**

Reviewed by   
(signature)

**Trevor Peterson**

Approved by   
(signature)

**Steve Pelletier**

## Table of Contents

<b>EXECUTIVE SUMMARY</b> .....	<b>1</b>
<b>1.0 INTRODUCTION</b> .....	<b>1</b>
<b>2.0 DATA COLLECTION METHODS</b> .....	<b>3</b>
<b>3.0 DATA ANALYSIS METHODS</b> .....	<b>5</b>
<b>4.0 RESULTS</b> .....	<b>8</b>
<b>5.0 DISCUSSION</b> .....	<b>11</b>
<b>6.0 REFERENCES</b> .....	<b>15</b>

### LIST OF TABLES

Table 4-1. Summary of bat detector field survey effort and results, VoltturnUS prototype wind turbine, 2014.....	8
Table 5-1. Summary of bat detector field survey effort and results, Dice Head Lighthouse 2012 & 2013, VoltturnUS prototype wind turbine, 2014.....	13

### LIST OF FIGURES

Figure 1-1. Project Location Map.....	2
Figure 2-1. VoltturnUS prototype wind turbine, offshore near Castine, ME, 2014. Red arrow indicates location of paired detectors. ....	3
Figure 2-2. Paired acoustic detector deployment, VoltturnUS prototype wind turbine, 2014. ....	5
Figure 4-2. Number of recorded call sequences by species/guild by survey night and mean nightly temperature, VoltturnUS prototype wind turbine, 2014.....	9
Figure 4-3. Number of recorded call sequences by species/guild by survey night and mean nightly wind speed, VoltturnUS prototype wind turbine, 2014.....	9
Figure 4-4. Number of recorded call sequences versus temperature (left) and wind speed (right), VoltturnUS prototype wind turbine, 2014.....	10
Figure 4-5. Number of recorded call sequences by hour past sunset, VoltturnUS prototype wind turbine, 2014.....	10
Figure 4-6. Number of recorded call sequences by guild, VoltturnUS prototype wind turbine, 2014. ....	11

### LIST OF APPENDICES

<b>APPENDIX A ACOUSTIC BAT SURVEY DATA TABLE</b> .....	<b>A.1</b>
--	------------

### Executive Summary

The DeepCWind Consortium, led by the University of Maine, has installed a prototype of a floating wind turbine (VolturnUS prototype wind turbine) in the waters of Penobscot Bay near Castine, Maine. Aligned with this effort, in 2014 Stantec Consulting Services Inc. (Stantec) conducted a third year of acoustic bat surveys to document seasonal bat activity in the general vicinity of the turbine deployment area. For the first two years of surveys, the acoustic bat surveys were conducted from the tower of the Dice Head Lighthouse in Castine, ME, the nearest feasible monitoring location to the site at which the prototype turbine would be deployed. For the third year of survey, Stantec deployed an ultrasonic acoustic bat detector system on the tower of VolturnUS prototype wind turbine itself. The 2014 surveys employed Anabat system detectors, the same type of acoustic detectors that were used in 2012 and 2013 monitoring as well as for a regional offshore study conducted by Stantec along the Atlantic coast and in the Great Lakes since 2009, funded by Stantec and the U.S. Department of Energy.

An acoustic detector system consisting of primary and backup detectors was deployed on the VolturnUS prototype wind turbine on 17 July 2014. The detector was fixed to the side of the tower at a height of approximately 5.5 meters above the water. The primary detector operated on a nightly basis through the night of 17 December 2014. A total of 277 bat call sequences were recorded during this 154-night period. Between 0 and 40 call sequences were recorded per night, with an overall activity level of 3.0 call sequences per detector-night during the period between 15 July and 15 October (a period used for seasonal comparisons in other studies). Bats were detected during 56 of the 91 nights (62%) surveyed between 15 July and 15 October. Of the 277 recorded call sequences, 170 (61%) were identified to species or guild and the remaining 107 call fragments were either too short, or lacked sufficient characteristic detail to be identified to species, and were classified as either high frequency or low frequency "unknown." The BBSH guild, including the big brown bat (*Eptesicus fuscus*) and silver-haired bat (*Lasionycteris noctivagans*) was the most frequently identified guild, followed by RBTB (including the eastern red bat [*Lasiurus borealis*] and tricolored bat [*Perimyotis subflavus*]) guilds. Least frequently identified and with a similar level of detected activity were *Myotis spp.* and hoary bat (*Lasiurus cinereus*) guilds.

Bat activity occurred during more than half of nights monitored between 15 July and 15 October. As such, bat presence at the prototype turbine was relatively consistent during this period and not unlike those documented at a series of offshore structures monitored as part of the regional offshore acoustic survey previously conducted by Stantec between 2009 and 2011 and between 2012 and 2014. Both the nightly range in activity levels and variability among survey nights seen during each survey year are typical of this type of survey. Timing of the busiest night of bat activity recorded varied among years, however these large pulses of activity are most likely caused by ideal conditions for foraging or migration (i.e., typically involving warm temperatures and low wind speeds).

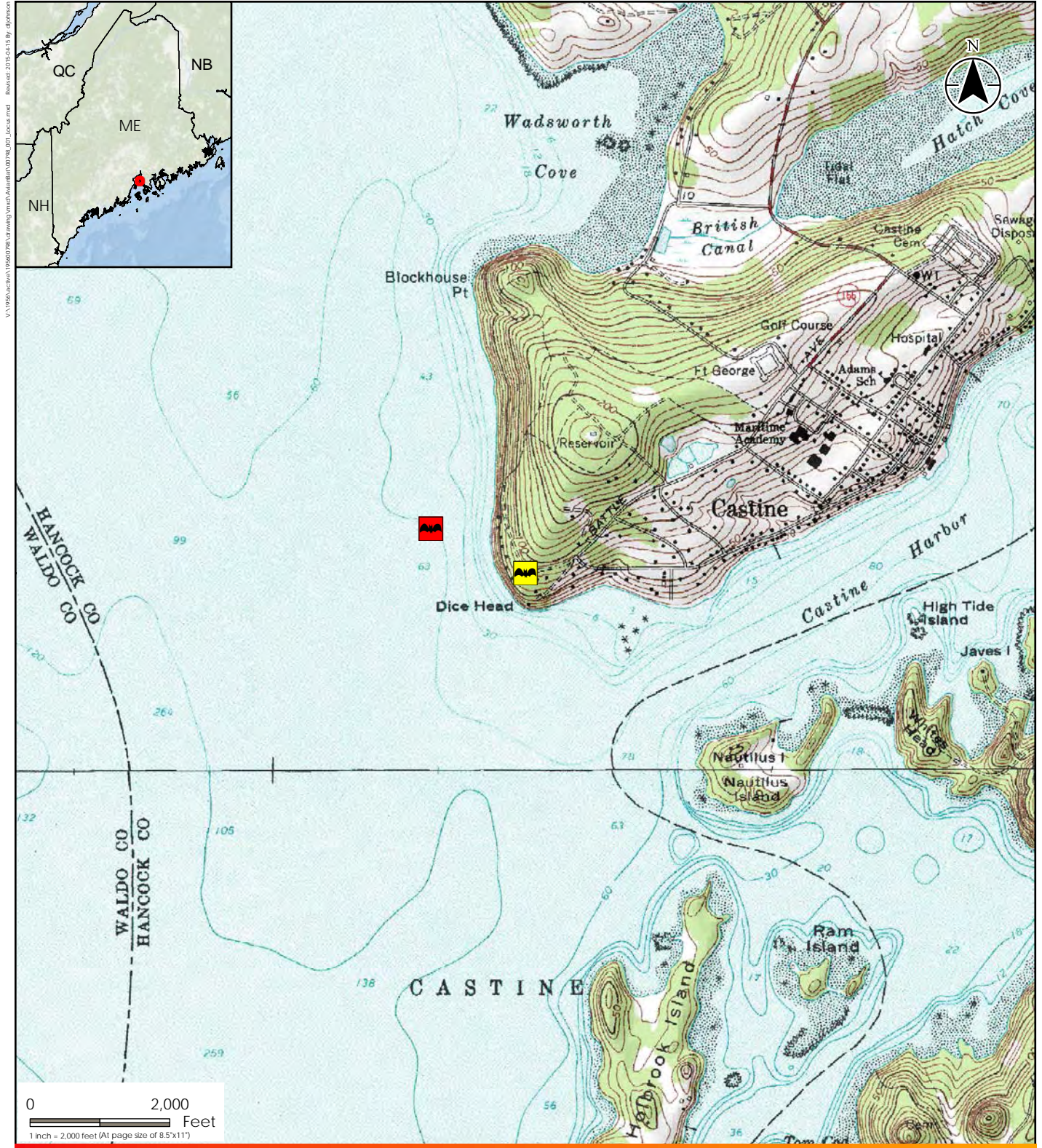
June 5, 2015

### 1.0 INTRODUCTION

The DeepCWind Consortium, led by the University of Maine, has installed a 1/8-scale prototype floating wind turbine (VoluternUS prototype wind turbine) in the waters of Penobscot Bay near Castine, Maine. In 2014, Stantec Consulting Services Inc. (Stantec) conducted a third year of acoustic bat surveys to document seasonal bat activity in the general vicinity of the turbine deployment area. For the first 2 years, the acoustic bat surveys were conducted from the tower of the Dice Head Lighthouse in Castine, ME, the nearest feasible monitoring location to the site at which the prototype turbine would be deployed. For the third year of survey, Stantec deployed an ultrasonic acoustic bat detector system on the tower of VoltturnUS prototype wind turbine itself (Figure 1-1). Bat detectors operated on the turbine from mid-July through mid-December 2014. The 2014 surveys employed Anabat system detectors, the same type of acoustic detectors that were used in 2012 and 2013 monitoring as well as for a regional offshore study conducted by Stantec in the Gulf of Maine since 2009. The Gulf of Maine acoustic studies were expanded to the mid-Atlantic coast and Great Lakes in 2011 with funding by Stantec and the U.S. Department of Energy.

Bats use high frequency echolocation to maneuver through the landscape during migration or in search of food and water. Acoustic bat detectors can record these calls, which are above the frequency range of human hearing. Acoustic sampling of bat activity has become a standard pre-construction survey for proposed wind-energy development (Kunz et al. 2007). This type of sampling allows for long-term passive monitoring in a variety of habitat types and locations. Although acoustic surveys are associated with several major assumptions (Hayes 2000) and results cannot generally be used to determine the number of bats inhabiting an area, acoustic surveys can provide insight into patterns in bat activity, species composition, and use of an area.

Eight species of bats are known to occur in Maine, based upon their normal geographical range. These are the little brown bat (*Myotis lucifugus*), northern long-eared bat, (*M. septentrionalis*), eastern small-footed bat (*M. leibii*), silver-haired bat (*Lasiurus noctivagans*), tri-colored bat (*Perimyotis subflavus*), big brown bat (*Eptesicus fuscus*), eastern red bat (*Lasiurus borealis*), and hoary bat (*L. cinereus*) (DeGraaf and Yamasaki 2001). All eight species could potentially occur in the mid-coast survey region, and fall within the recordable range of acoustic bat detectors.



Disclaimer: Stantec assumes no responsibility for data supplied in electronic format. The recipient accepts full responsibility for verifying the accuracy and completeness of the data. The recipient releases Stantec, its officers, employees, consultants and agents, from any and all claims arising in any way from the content or provision of the data.



195600798



30 Park Drive  
 Topsham, ME USA 04086  
 Phone (207) 729-1199

Prepared by DLJ on 2015-04-15  
 Reviewed by LSB on 2015-04-15

**Legend**

-  2012 & 2013 Acoustic Bat Survey Location (Dice Head Light House)
-  2014 Acoustic Bat Survey Location (VoltturnUS Prototype)

Client/Project  
 University of Maine  
 Acoustic Bat Survey  
 Castine, Maine

Figure No.  
 1

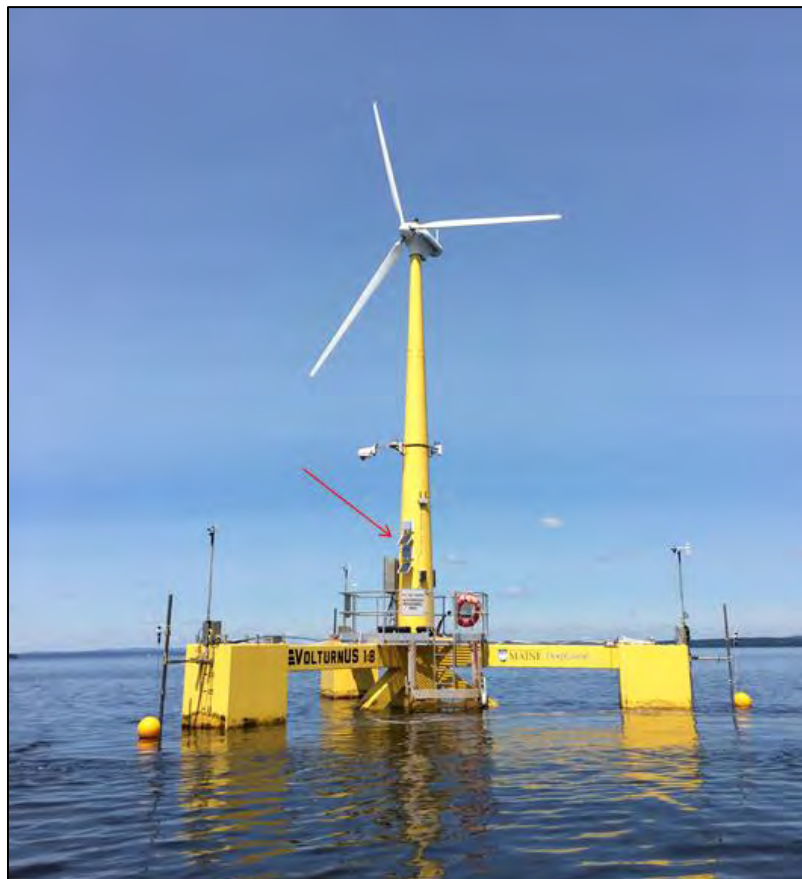
Title  
 Project Location Map  
 4/15/2015



June 5, 2015

## 2.0 DATA COLLECTION METHODS

One SD1-based acoustic detector system consisting of a primary and backup detector was deployed at the base of the VoltturnUS prototype wind turbine at a height of approximately 5.5 meters (m) above sea level. The turbine is located approximately 250 m from the shoreline (Figure 2-1).



**Figure 2-1. VoltturnUS prototype wind turbine, offshore near Castine, ME, 2014. Red arrow indicates location of paired detectors.**

Anabat SD1 detectors (Titley Electronics Pty Ltd.) are commonly used for this type of data collection because of their ability to be deployed for long periods of time, and their ability to detect a broad frequency range, which allows detection of all species of bats that could occur within the region in Maine. Anabat detectors are frequency division detectors, dividing the frequency of echolocation sounds made by bats by a factor of 16, and then recording these sounds onto removable compact flash cards for subsequent analysis. Detectors were

## 2014 ACOUSTIC BAT SURVEY REPORT

June 5, 2015

programmed to begin monitoring at 18:00 hours each night, and end monitoring at 08:00 hours each morning. The audio sensitivity setting of each Anabat system was set between 6 and 7 (on a scale of 1 to 10) to maximize sensitivity while limiting ambient background noise and interference. Prior to deployment, the sensitivity of each detector was tested using an ultrasonic Bat Chirp (Reno, NV) to determine that the detectors would be able to detect bats up to a distance of at least 10 m.

The acoustic system consisted of 2 SD1 detectors, each powered by a single 12-volt battery charged by a 10-watt solar panel. The SD1 detectors were deployed in separate waterproof housings with a 90 degree PVC elbow used to direct bat calls into the microphone while protecting the units from the weather (Figure 2-2). Stantec has used this method of detector deployment at a variety of land-based and offshore sites, including previous monitoring at the Dice Head Lighthouse. Temperature and wind speed data were collected from the DeepCWind Castine test site buoy also located just offshore near the Dice Head Lighthouse.

June 5, 2015



**Figure 2-2. Paired acoustic detector deployment, VoltturnUS prototype wind turbine, 2014.**

### 3.0 DATA ANALYSIS METHODS

Ultrasound recordings of bat echolocation may be broken into recordings of a single bat call or recordings of bat call sequences. A call is a single pulse of sound produced by a bat, while a call sequence is a combination of 2 or more pulses recorded in an Anabat file. Recordings containing less than 2 calls were eliminated from analysis as has been done in similar studies (Arnett et al. 2006). Call sequences typically include a series of calls characteristic of normal flight or prey location ("search phase") and capture periods (feeding "buzzes").

Potential call files were extracted from data files using CFCread® software. The default settings for CFCread® were used during the extraction and are recommended for calls that are characteristic of bats in the Northeast. This software screens all data recorded by the detector and extracts bat call files using a filter. Settings used by the filter include a max TBC (time between calls) of 5 seconds, a minimum line length of 5 milliseconds, and a smoothing factor of 50. The smoothing factor refers to whether or not adjacent pixels can be connected with a

## 2014 ACOUSTIC BAT SURVEY REPORT

June 5, 2015

smooth line. The higher the smoothing factor, the less restrictive the filter and the more noise files and poor quality call sequences that are retained within the data set.

Following extraction of call files, each file was visually inspected to ensure that only bat calls were included in the data set. Insect activity, wind, and interference can also produce Anabat files that pass through the initial filter and need to be visually inspected and removed from the data set. Call sequences are easily differentiated from other recordings, which typically form a diffuse band of dots at either a constant frequency or widely varying frequency.

Bat call sequences were individually marked and categorized by species group, or “guild” based on visual comparison to reference calls. Qualitative visual comparison of recorded call sequences of sufficient length to reference libraries of bat calls allows for relatively accurate identification of bat species (O’Farrell et al. 1999, O’Farrell and Gannon 1999). Call sequences were classified to species whenever possible, based on criteria developed from review of reference calls collected by Chris Corben - the developer of the Anabat system, as well as other bat researchers. However, due to similarity of call signatures between several species, all classified calls have been categorized into 5 guilds<sup>1</sup> reflecting the bat community in the region of the study area:

- **Unknown (UNKN)** – All call sequences with less than 5 calls, or poor quality sequences (those with indistinct call characteristics or background static). These sequences were further identified as either “high frequency unknown” (HFUN) for sequences with a minimum frequency above 30– 35 kHz, or “low frequency unknown” (LFUN) for sequences with a minimum frequency below 30– 35 kHz. For this area, HFUN most likely represents eastern red bats, tri-colored bats, and *Myotis* species. LFUN likely represents big brown, silver-haired, and hoary bats species.
- **Myotis (MYSP)** – All bats of the genus *Myotis*. While there are some general characteristics believed to be distinctive for the 3 species in this genus for this area (little brown, northern long-eared, and eastern small-footed bats), these characteristics are not sufficiently consistent to be relied upon for current species identification at all times when using Anabat recordings.
- **Big brown bat/silver-haired bat (BBSH)** – Big brown (EPFU) and silver-haired (LANO) bats. These species’ call signatures commonly overlap and have therefore been included as 1 guild in this report.
- **Hoary bat (HB)** – Hoary bats. Calls of hoary bats can usually be distinguished from those of big brown and silver-haired bats by minimum frequency extending below 20 kHz or by calls varying widely in minimum frequency across a sequence.

---

<sup>1</sup> Gannon et al. 2003 categorized bats into guilds based upon similar minimum frequency and call shape. These guilds were: Unidentified, *Myotis*, LABO-PESU and EPFU-LANO-LACI. To report the activity of the migratory hoary bat, it was placed into a separate guild.

## 2014 ACOUSTIC BAT SURVEY REPORT

June 5, 2015

- **Eastern red bat/tri-colored bat<sup>2</sup> (RBTB)** – Eastern red (LABO) and tri-colored (PESU). These species can produce distinctive calls; however, significant overlap in the call pulse shape, frequency range, and slope can also occur between red bats and tri-colored bats.

This method of guild-level identification represents a conservative approach to bat data analysis. Because some species occasionally produce calls unique only to that species, all calls were identified to the lowest possible taxonomic level before being grouped into the listed guilds. Tables and figures in the body of this report will reflect those guilds. However, since by-hand analysis methods output species-specific identification of high quality calls, species level composition of bat calls will also be discussed.

Once all of the call files were identified and categorized in appropriate guilds, nightly tallies of detected calls were compiled, and mean detection rates (number of recordings/detector-night) were calculated for the period between 15 July and 15 October (to allow comparison with regional offshore acoustic data, which were summarized for this same date range). Because bat activity levels are highly variable among individual nights and hours (Arnett et al. 2006, Hayes 1997), detection rates were summarized on both of these temporal scales. Hourly detection rates were summarized by hour after sunset, as recommended by Kunz et al. (2007). Quantitative comparisons among these temporal periods was not attempted because the high amount of variability associated with bat detection would have required much larger sample sizes (Arnett et al. 2006, Hayes 1997).

For purposes of comparing results from this study to regional offshore monitoring efforts conducted elsewhere in the Gulf of Maine, Stantec also calculated an index known as the Gini Coefficient to represent the degree of inconsistency in the distribution of activity. This index, originally developed for analyzing distribution of income, has been used by population demographers as well (Shyrock and Siegel 1980). The index ranges from 0, representing completely uniform distribution (i.e., the same number of passes recorded each night) to 1, representing completely uneven distribution of bat activity (i.e., all bat passes recorded during a single night). Stantec calculated the Gini Coefficient for each site monitored between 2009 and 2014 in its regional offshore acoustic study, providing a robust baseline to which data from this project could be compared (Stantec draft report in preparation). In both cases, we calculated this coefficient for the period between 15 July and 15 October, using only data from sites monitored for 30 or more nights within this period.

---

<sup>2</sup> The scientific and common name of the eastern pipistrelle (*Pipistrellus subflavus*) has been changed to the tri-colored bat (*Perimyotis subflavus*).

## 2014 ACOUSTIC BAT SURVEY REPORT

June 5, 2015

### 4.0 RESULTS

The primary acoustic detector operated successfully on 154 nights between 17 July and 17 December 2014. A total of 277 bat call sequences were recorded during this period (**Error! Reference source not found.**). Between 0 and 40 call sequences were recorded per detector-night, with an overall average nightly activity level of 3.0 call sequences per detector-night during the 91 nights monitored between 15 July and 15 October. Bats were detected during 56 out of the 91 surveyed nights (62%) within this period. The busiest night of activity (7 September 2014) accounted for 14% (n = 40) of total recorded bat activity during the 5-month survey period. On this night, bat activity occurred between 52 minutes past sunset until 7 hours, 24 minutes past sunset, and half of recorded bat passes were identified as silver-haired bats.

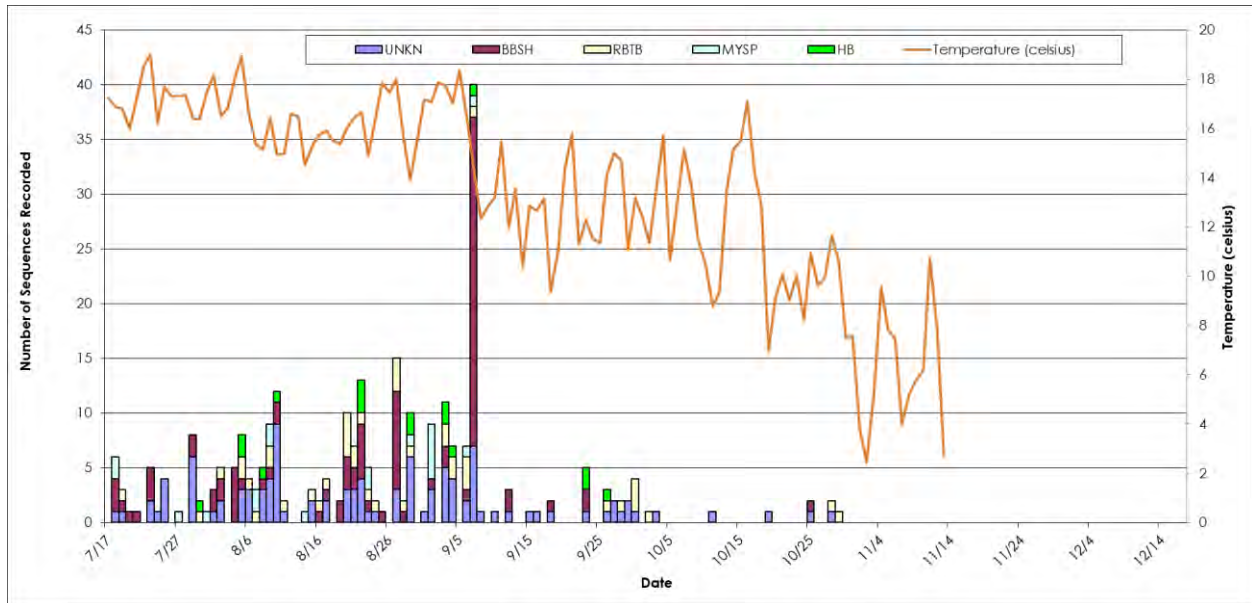
**Table 4-1. Summary of bat detector field survey effort and results, VoltturnUS prototype wind turbine, 2014.**

Location	Dates Deployed	Calendar Nights	Detector-Nights*	Recorded Sequences	Detection Rate **	Gini Coefficient* **	Maximum Sequences recorded ****
Primary Detector	17 July - 1 Dec.	154	154	277	3.0	0.69	40
* One detector-night is equal to a one detector successfully operating throughout the night.							
** Number of bat echolocation sequences recorded per detector-night within the subset of acoustic data between 15 July and 15 October .							
*** Gini coefficient calculated within the subset of acoustic data between 15 July and 15 October .							
**** Maximum number of bat passes recorded from any single detector for a detector-night within the subset of acoustic data between 15 July and 15 October .							

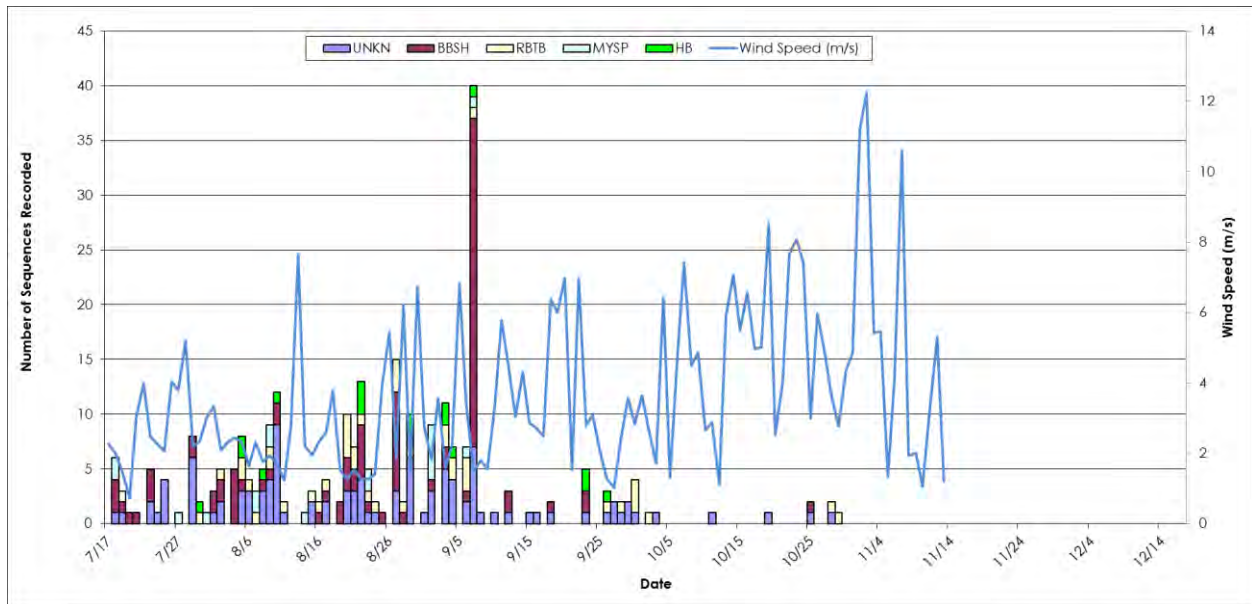
Mean nightly temperatures ranged from 2°C (36°F) to 19°C (66°F) during the survey period, with mean nightly wind speed ranging from 1 m/s to 12 m/s (Figure 4-1 and Figure 4-2). Nightly bat activity levels appeared to be positively correlated with nightly mean temperature and negatively correlated with nightly wind speed (Figure 4-3). Appendix A Table 1 provides nightly summaries of acoustic bat activity by survey night as well as nightly mean temperature and wind speed.

# 2014 ACOUSTIC BAT SURVEY REPORT

June 5, 2015



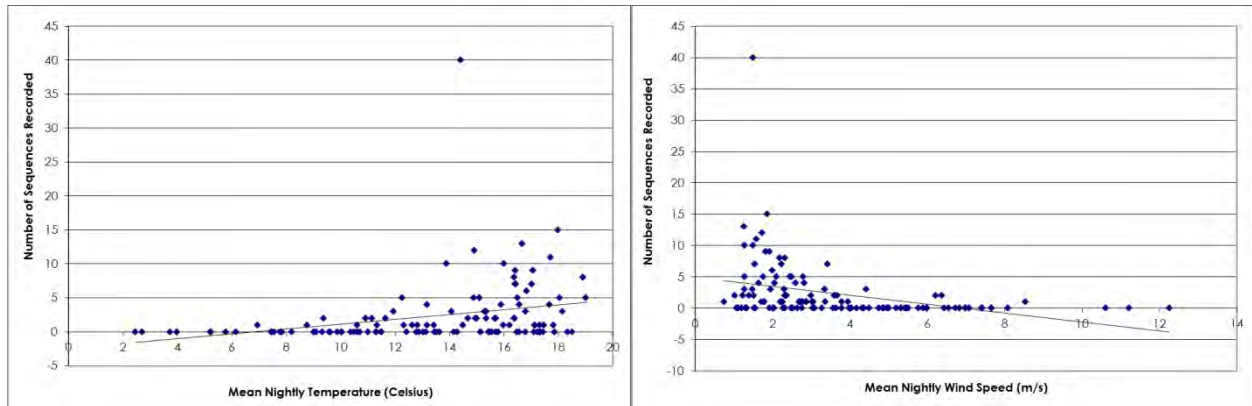
**Figure 4-1. Number of recorded call sequences by species/guild by survey night and mean nightly temperature, VoltturnUS prototype wind turbine, 2014.**



**Figure 4-2. Number of recorded call sequences by species/guild by survey night and mean nightly wind speed, VoltturnUS prototype wind turbine, 2014.**

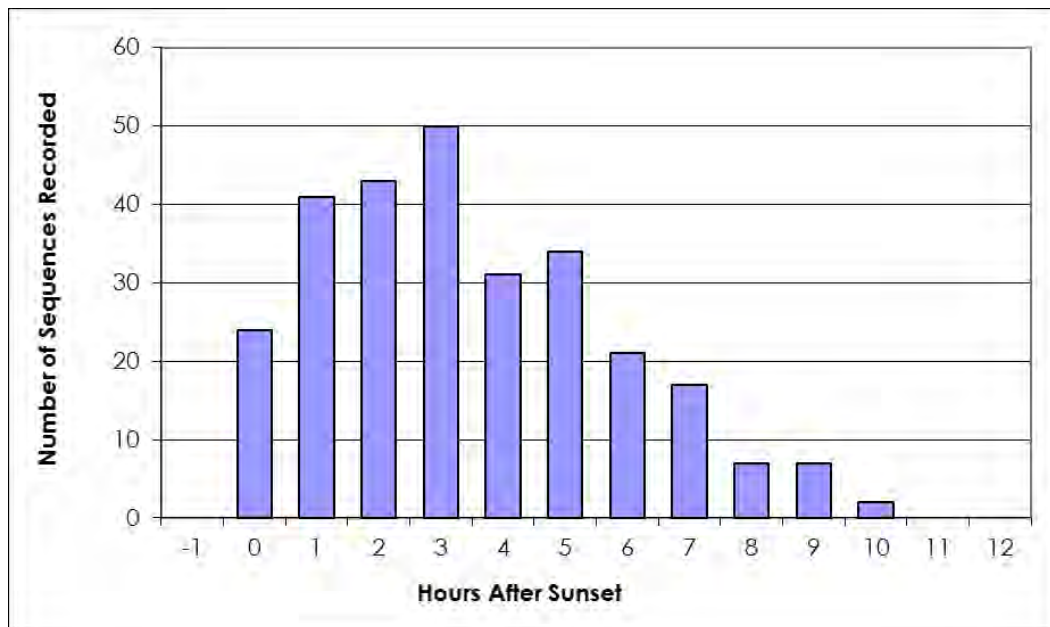
## 2014 ACOUSTIC BAT SURVEY REPORT

June 5, 2015



**Figure 4-3. Number of recorded call sequences versus temperature (left) and wind speed (right), VolturnUS prototype wind turbine, 2014.**

Distribution of nightly timing by hour past sunset varied considerably among survey nights, although the highest number of calls peaked during the third hour past sunset then declined until 10 hours past sunset (Figure 4-4).



**Figure 4-4. Number of recorded call sequences by hour past sunset, VolturnUS prototype wind turbine, 2014.**

Of the 277 recorded call sequences, 170 (61%) were identified to species or guild. The remaining 107 call fragments were either too short, or lacked sufficient characteristics to be identified and were classified as either high frequency or low frequency “unknown” (Figure 4-5). The BBSH guild, including the big brown bat and silver-haired bat, was the most frequently identified guild, followed by the RBTB guild, including the eastern red bat and tricolored bat. The least frequently



## 2014 ACOUSTIC BAT SURVEY REPORT

June 5, 2015

identified guilds, with similar levels of detected activity, were *Myotis spp.* and hoary bat. Within the BBSH guild, 43 sequences (47%) were classified as silver-haired bats, and 9 sequences (10%) were classified as big brown bats, with the remaining 39 sequences (43%) identified to guild only. Seventeen hoary bats were identified. A total of 19 calls were identified to the *Myotis spp.* guild level. Within the RBTB guild, 31 sequences (72%) were classified as eastern red bats and 0 sequences were identified as tri-colored bats, leaving 12 sequences (28%) identified to guild only.

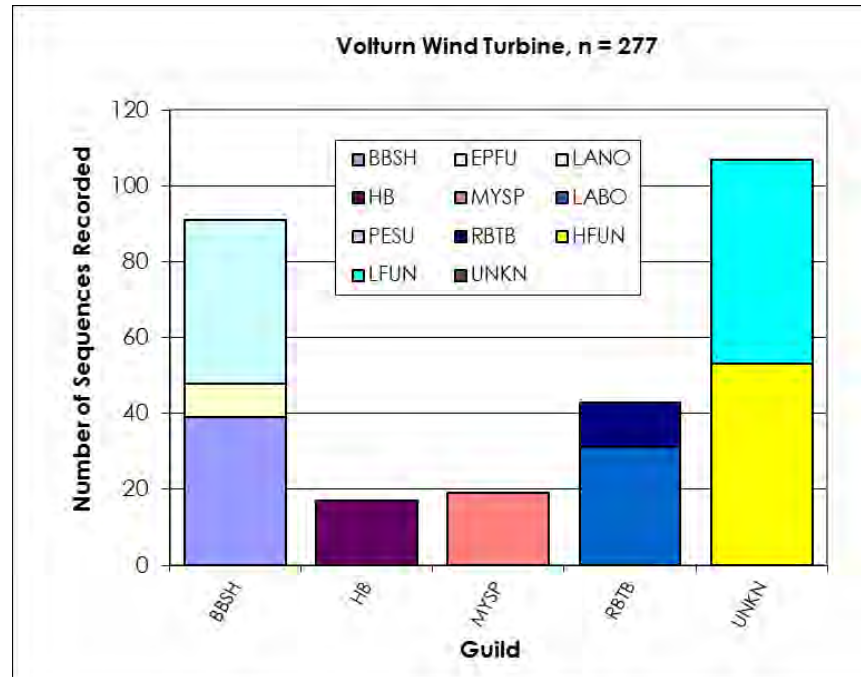


Figure 4-5. Number of recorded call sequences by guild, VoltturnUS prototype wind turbine, 2014.

## 5.0 DISCUSSION

Bat activity occurred during more than half of nights monitored between 15 July and 15 October. As such, bat presence at the prototype turbine was relatively consistent during this period and not unlike those documented at a series of offshore structures monitored as part of the regional offshore acoustic survey conducted by Stantec between 2009 and 2011 (Peterson et al. 2014) and between 2012 and 2014 (Stantec 2015 draft report under review). Acoustic monitoring at a weather buoy (NERACOOS Buoy F) in the same vicinity as the prototype turbine documented detection rates of 3.04 passes per night during the period from 15 July through 15 October 2013, with bats detected during 57% of surveyed nights within this period, which are remarkably similar to the rates documented in 2014 at the turbine. Similarly, the Gini Coefficient of 0.69 calculated for the prototype turbine was similar to that of 0.71 calculated for the buoy. The Gini Coefficients calculated for acoustic survey results at 4 additional buoys monitored in the Gulf of Maine between 2011 and 2014 were all higher than that calculated for the prototype

## 2014 ACOUSTIC BAT SURVEY REPORT

June 5, 2015

turbine (indicating more consistent activity at the turbine), although these buoys were all substantially more remote than the prototype turbine. Nevertheless, seasonal timing of acoustic bat activity documented at the prototype turbine was similar to that documented at a variety of other offshore structures in the Gulf of Maine that were monitored using similar methods by Stantec between 2009 and 2014.

Previous acoustic bat surveys conducted at this project occurred at the Dice Head Lighthouse, located approximately 475 m southeast of the prototype turbine. Acoustic surveys took place at Dice Head between 22 May and 10 July 2012 and 14 May and 11 October 2013, providing an opportunity to compare results among years and locations. Prior seasonal (15 July through 15 October 2012 and 2013) detection rates were higher at Dice Head than at the prototype turbine (Table 5-1). The Gini Coefficient was higher for the turbine than the lighthouse, indicating that bat activity was more sporadic at the turbine. This reduced activity level at the turbine however is not unexpected given that the lighthouse is a coastal mainland site with surrounding trees and viable bat roost habitat.

Differences in characteristics between the lighthouse and prototype turbine likely explain many of the differences in survey results between the sites, such as species composition. Also, effects of White-nose syndrome may be apparent in the decline of *Myotis* species calls between 2012 and 2013 at Dice Head Lighthouse. *Myotis* species comprised approximately 73% of bat passes categorized to species or species group at the Dice Head Lighthouse in 2012 and approximately 16% of bat passes categorized to species or species group in 2013 at Dice Head and in 2014 at the prototype turbine. Lastly, time of year during which monitoring occurred differed between 2012 and 2013, potentially contributing to differences when comparing results from these years at the Dice Head Lighthouse.

Bat fatality rates at terrestrial wind power sites are typically highest during the fall migratory period. Year 2012 surveys conducted at the Dice Head Lighthouse occurred only during the summer residency period, from May to mid-July. To measure activity during the more vulnerable fall migratory period, the 2013 acoustic survey period was extended into mid-October and the 2014 acoustic survey period conducted from the offshore VoltturnUS prototype wind turbine extended into December. During both 2013 and 2014, nightly activity levels peaked in late August or early September, coinciding with the typical peak in turbine-related bat mortality at land-based projects. Similar seasonal patterns occurred at most sites monitored in the 2009 – 2014 regional offshore acoustic bat monitoring study (Stantec draft report in review).

## 2014 ACOUSTIC BAT SURVEY REPORT

June 5, 2015

**Table 5-1. Summary of bat detector field survey effort and results, Dice Head Lighthouse 2012 & 2013, VoltturnUS prototype wind turbine, 2014.**

Location	Dates Deployed	Calendar Nights	Detector-Nights*	Recorded Sequences	Detection Rate **	Gini Coefficient ***	Maximum Sequences recorded ****
2012 (Dice Head lighthouse)	22 May - 10 July	50	50	797	–	–	–
2013 (Dice Head lighthouse)	14 May - 11 Oct.	151	151	1,326	9.9	0.51	102
2014 (VoltturnUS prototype wind turbine)	17 July - 17 Dec.	154	154	277	3.0	0.69	40

\* One detector-night is equal to a one detector successfully operating throughout the night.  
 \*\* Number of bat echolocation sequences recorded per detector-night within the subset of acoustic data between 15 July and 15 October .  
 \*\*\* Gini coefficient calculated within the subset of acoustic data between 15 July and 15 October .  
 \*\*\*\* Maximum number of bat passes recorded from any single detector for a detector-night within the subset of acoustic data between 15 July and 15 October .

Both the nightly range in activity levels and variability among survey nights seen during each survey year are typical of this type of survey. Timing of the busiest night of bat activity recorded varied among years, however these large pulses of activity are most likely caused by ideal conditions for foraging or migration (i.e., typically involving warm temperatures and low wind speeds).

Observations to date reveal bats are detected more consistently at coastal locations and less consistently at more remote offshore survey locations, such as buoys and isolated rocky islands with limited foraging or roosting habitat. Such was the case in comparing bat activity patterns between the Dice Head Lighthouse and the prototype turbine. Whereas regional surveys have focused on the fall migratory period, limited available datasets suggest comparatively lower activity levels offshore during the summer period (June and July) relative to the fall (mid-August through mid-September). Data recorded at the offshore VoltturnUS prototype wind turbine in 2014 reflect this trend; activity levels were greatest during August and September.

Bat activity typically peaked the second or third hour after sunset on a nightly basis during the 2013 and 2014 survey period. However, activity peaked during the seventh hour after sunset during the 2012 survey period. Although available data are insufficient to support any conclusion, this activity may be indicative of bats returning to the mainland after offshore or nearshore migration activity.

Recent studies have found that bat activity patterns are influenced by weather conditions (Arnett et al. 2006, Arnett et al. 2008, Reynolds 2006). Acoustic surveys have documented a decrease in bat activity rates as wind speed increases and temperature decreases, and bat activity has been shown to correlate negatively to low nightly mean temperatures (Hayes 1997, Reynolds 2006). Multiple weather variables can individually affect bat activity, as does the interaction among variables (i.e., warm nights with low wind speeds). Although weather data

## 2014 ACOUSTIC BAT SURVEY REPORT

June 5, 2015

were collected 60 miles south of Castine during 2012 and 2013, bat activity levels did appear to be higher on warmer nights, and higher on warmer and calmer nights in 2014.

When considering the level of activity documented at the Dice Head Lighthouse and VoltturnUS prototype wind turbine, it is important to acknowledge that numbers of recorded call sequences cannot be accurately correlated with the number of individual bats in an area because acoustic detectors cannot differentiate between individuals (Hayes 2000). Thus, results of acoustic surveys must be interpreted with caution. Methods surrounding acoustic surveys are continually evolving, and there is currently little data aiding in the interpretation of the number of calls per detector nights. Although interpretations are limited, the surveys represent a sample of activity, activity timing, and the general species groups that occur in the area of the survey location.

## 2014 ACOUSTIC BAT SURVEY REPORT

June 5, 2015

### 6.0 REFERENCES

- Arnett, E. B., J.P. Hayes, and M.M.P. Huso. 2006. An evaluation of the use of acoustic monitoring to predict bat fatality at a proposed wind facility in south central Pennsylvania. An annual report submitted to the Bats and Wind Energy Cooperative. Bat Conservation International. Austin, Texas, USA.
- Arnett, E.B., W.K. Brown, W.P. Erickson, J.K. Fiedler, B.L. Hamilton, T.H. Henry, A. Jain, G.D. Johnson, J. Kerns, R.R. Koford, C.P. Nicholson, T.J. O'Connell, M.D. Piorkowski, and R.D. Takersley Jr. 2008. Patterns of bat fatalities at wind energy facilities in North America. *Journal of Wildlife Management* 72:61-78.
- Hayes, J.P. 1997. Temporal variation in activity of bats and the design of echolocation monitoring studies. *Journal of Mammalogy* 78:1-524.
- DeGraaf, R.M. and M. Yamasaki. 2001. *New England Wildlife; Habitat, Natural History, and Distribution*. University Press of New England, Hanover, NH. 482p.
- Gannon, W.L., R.E. Sherwin, and S. Haywood. 2003. On the importance of articulating assumptions when conducting acoustic studies of habitat use by bats. *Wild. Soc. Bull.* 31 (1):45-61.
- Hayes, J.P. 1997. Temporal variation in activity of bats and the design of echolocation-monitoring studies. *Journal of Mammalogy* 78(2):514-524.
- Hayes, J.P. 2000. Assumptions and practical considerations in the design and interpretation of echolocation-monitoring studies. *Acta Chiropterologica* 2(2):225-236.
- Kunz, T.H., E.B. Arnett, B.M. Cooper, W.P. Erickson, R.P. Larkin, T. Mabee, M.L. Morrison, M.D. Strickland, and J.M. Szewczak. 2007. Assessing impacts of wind-energy development on nocturnally active birds and bats: A guidance document. *Journal of Wildlife Management* 71:2449-2486.
- O'Farrell, M.J., and W.L. Gannon. 1999. A comparison of acoustic versus capture techniques for the inventory of bats. *Journal of Mammalogy* 80(1):24-30.
- O'Farrell, M.J., B.W. Miller, and W.L. Gannon. 1999. Qualitative identification of free-flying bats using the anabat detector. *Journal of Mammalogy* 80(1):11-23.
- Peterson, T.S., S.K. Pelletier, S.A. Boyden, and K.S. Watrous. 2014. Offshore acoustic monitoring of bats in the Gulf of Maine. *Northeastern Naturalist*.
- Reynolds, D.S. 2006. Monitoring the potential impacts of a wind development site on bats in the Northeast. *Journal of Wildlife Management* 70(5):1219 - 1227.
- Shryock H .S. and Siegel J. S. 1980. *The Methods and Materials of Demography*. U.S. Bureau of the Census, U.S. Government Printing Office. Fourth Printing (rev).

**2014 ACOUSTIC BAT SURVEY REPORT**

June 5, 2015

**Appendix A ACOUSTIC BAT SURVEY DATA TABLE**

## 2014 ACOUSTIC BAT SURVEY REPORT

June 5, 2015

**Appendix A Table 1.** Summary of acoustic bat data and weather during each survey night at VoltturnUS prototype wind turbine – 2014.

Night of	Operational?	BBSH			HB	MYSP	RBTB			UNKN			Total	Wind Speed (m/s)	Temperature (celsius)	Atmospheric Pressure (mb)
		BBSH	Big brown	Silver-haired	Hoary	MYSP	Eastern red	Tri-colored	RBTB	HFUN	LFUN	UNKN				
07/17/14	1												0	2	17	1018
07/18/14	1	2	1			2						1	6	2	17	1024
07/19/14	1	1					1			1			3	1	17	1025
07/20/14	1	1											1	1	16	1023
07/21/14	1	1											1	3	17	1021
07/22/14	1												0	4	19	1014
07/23/14	1	3								1	1		5	2	19	1008
07/24/14	1											1	1	2	16	1012
07/25/14	1									1	3		4	2	18	1013
07/26/14	1												0	4	17	1011
07/27/14	1					1							1	4	17	1007
07/28/14	1												0	5	17	1000
07/29/14	1		2							3	3		8	2	16	1015
07/30/14	1				1		1						2	2	16	1018
07/31/14	1					1							1	3	17	1022
08/01/14	1	2									1		3	3	18	1024
08/02/14	1	2							1	2			5	2	17	1021
08/03/14	1												0	2	17	1018
08/04/14	1	5											5	2	18	1016
08/05/14	1		1		2		2					3	8	2	19	1012
08/06/14	1						1			3			4	2	17	1009
08/07/14	1					2	1						3	2	15	1012
08/08/14	1			1	1					1	2		5	2	15	1015
08/09/14	1	1				2	2			2	2		9	2	16	1018
08/10/14	1		2		1					4	5		12	2	15	1020
08/11/14	1						1					1	2	1	15	1021
08/12/14	1												0	3	17	1020
08/13/14	1												0	8	16	1007
08/14/14	1					1							1	2	15	1010
08/15/14	1						1			2			3	2	15	1011
08/16/14	1		1						1				2	2	16	1012

# 2014 ACOUSTIC BAT SURVEY REPORT

June 5, 2015

08/17/14	1	1						1	1	1		<b>4</b>	3	16	1007
08/18/14	1											<b>0</b>	4	16	1010
08/19/14	1	1		1								<b>2</b>	2	15	1014
08/20/14	1	2		1			3		1	2	1	<b>10</b>	1	16	1018
08/21/14	1			2			1		1	2	1	<b>7</b>	2	16	1020
08/22/14	1			5	3		1			2	2	<b>13</b>	1	17	1020
08/23/14	1			1		2	1			1		<b>5</b>	1	15	1020
08/24/14	1						1			1		<b>2</b>	1	16	1019
08/25/14	1		1									<b>1</b>	4	18	1020
08/26/14	1											<b>0</b>	5	17	1015
08/27/14	1	2		7			1		2	3		<b>15</b>	2	18	1010
08/28/14	1	1							1			<b>2</b>	6	16	1014
08/29/14	1				2	1	1			4	2	<b>10</b>	2	14	1025
08/30/14	1											<b>0</b>	7	16	1019
08/31/14	1								1			<b>1</b>	3	17	1014
09/01/14	1		1			5				3		<b>9</b>	2	17	1014
09/02/14	1											<b>0</b>	4	18	1007
09/03/14	1	2			2		1		1	2	3	<b>11</b>	2	18	1017
09/04/14	1				1		1		1	1	3	<b>7</b>	2	17	1019
09/05/14	1											<b>0</b>	7	18	1013
09/06/14	1			1		1	3			1	1	<b>7</b>	3	16	1012
09/07/14	1	10		20	1	1			1	2	5	<b>40</b>	1	14	1023
09/08/14	1										1	<b>1</b>	2	12	1030
09/09/14	1											<b>0</b>	2	13	1025
09/10/14	1									1		<b>1</b>	3	13	1018
09/11/14	1											<b>0</b>	6	15	1010
09/12/14	1	1		1							1	<b>3</b>	4	12	1024
09/13/14	1											<b>0</b>	3	14	1020
09/14/14	1											<b>0</b>	4	10	1023
09/15/14	1										1	<b>1</b>	3	13	1019
09/16/14	1										1	<b>1</b>	3	13	1015
09/17/14	1											<b>0</b>	2	13	1014
09/18/14	1			1							1	<b>2</b>	6	9	1022
09/19/14	1											<b>0</b>	6	11	1029
09/20/14	1											<b>0</b>	7	14	1018
09/21/14	1											<b>0</b>	2	16	1001
09/22/14	1											<b>0</b>	7	11	1016
09/23/14	1			2	2						1	<b>5</b>	3	12	1030
09/24/14	1											<b>0</b>	3	12	1036
09/25/14	1											<b>0</b>	2	11	1025
09/26/14	1				1				1		1	<b>3</b>	1	14	1020
09/27/14	1									1	1	<b>2</b>	1	15	1021
09/28/14	1						1				1	<b>2</b>	2	15	1014



## 2014 ACOUSTIC BAT SURVEY REPORT

June 5, 2015

09/29/14	1								2			<b>2</b>	4	11	1019
09/30/14	1					3			1			<b>4</b>	3	13	1019
10/01/14	1											<b>0</b>	4	12	1022
10/02/14	1					1						<b>1</b>	3	11	1022
10/03/14	1									1		<b>1</b>	2	13	1014
10/04/14	1											<b>0</b>	6	16	1003
10/05/14	1											<b>0</b>	1	11	1013
10/06/14	1											<b>0</b>	5	13	1023
10/07/14	1											<b>0</b>	7	15	1016
10/08/14	1											<b>0</b>	4	14	1008
10/09/14	1											<b>0</b>	5	11	1013
10/10/14	1											<b>0</b>	3	11	1019
10/11/14	1									1		<b>1</b>	3	9	1019
10/12/14	1											<b>0</b>	1	9	1026
10/13/14	1											<b>0</b>	6	13	1024
10/14/14	1											<b>0</b>	7	15	1020
10/15/14	1											<b>0</b>	6	15	1017
10/16/14	1											<b>0</b>	7	17	1008
10/17/14	1											<b>0</b>	5	14	1004
10/18/14	1											<b>0</b>	5	13	1000
10/19/14	1									1		<b>1</b>	9	7	1010
10/20/14	1											<b>0</b>	3	9	1016
10/21/14	1											<b>0</b>	4	10	1020
10/22/14	1											<b>0</b>	8	9	1017
10/23/14	1											<b>0</b>	8	10	1006
10/24/14	1											<b>0</b>	7	8	1004
10/25/14	1	1									1	<b>2</b>	3	11	998
10/26/14	1											<b>0</b>	6	10	1001
10/27/14	1											<b>0</b>	5	10	1015
10/28/14	1						1			1		<b>2</b>	4	12	1015
10/29/14	1						1					<b>1</b>	3	11	1009
10/30/14	1											<b>0</b>	4	7	1016
10/31/14	1											<b>0</b>	5	8	1017
11/01/14	1											<b>0</b>	11	4	1011
11/02/14	1											<b>0</b>	12	2	1004
11/03/14	1											<b>0</b>	5	5	1015
11/04/14	1											<b>0</b>	5	10	1017
11/05/14	1											<b>0</b>	1	8	1018
11/06/14	1											<b>0</b>	4	7	1003
11/07/14	1											<b>0</b>	11	4	1002
11/08/14	1											<b>0</b>	2	5	1012
11/09/14	1											<b>0</b>	2	6	1016
11/10/14	1											<b>0</b>	1	6	1023

# 2014 ACOUSTIC BAT SURVEY REPORT

June 5, 2015

11/11/14	1													0	3	11	1017
11/12/14	1													0	5	8	1014
11/13/14	1													0	1	3	1014
11/14/14	1													0	NA	NA	NA
11/15/14	1													0	NA	NA	NA
11/16/14	1													0	NA	NA	NA
11/17/14	1													0	NA	NA	NA
11/18/14	1													0	NA	NA	NA
11/19/14	1													0	NA	NA	NA
11/20/14	1													0	NA	NA	NA
11/21/14	1													0	NA	NA	NA
11/22/14	1													0	NA	NA	NA
11/23/14	1													0	NA	NA	NA
11/24/14	1													0	NA	NA	NA
11/25/14	1													0	NA	NA	NA
11/26/14	1													0	NA	NA	NA
11/27/14	1													0	NA	NA	NA
11/28/14	1													0	NA	NA	NA
11/29/14	1													0	NA	NA	NA
11/30/14	1													0	NA	NA	NA
12/01/14	1													0	NA	NA	NA
12/02/14	1													0	NA	NA	NA
12/03/14	1													0	NA	NA	NA
12/04/14	1													0	NA	NA	NA
12/05/14	1													0	NA	NA	NA
12/06/14	1													0	NA	NA	NA
12/07/14	1													0	NA	NA	NA
12/08/14	1													0	NA	NA	NA
12/09/14	1													0	NA	NA	NA
12/10/14	1													0	NA	NA	NA
12/11/14	1													0	NA	NA	NA
12/12/14	1													0	NA	NA	NA
12/13/14	1													0	NA	NA	NA
12/14/14	1													0	NA	NA	NA
12/15/14	1													0	NA	NA	NA
12/16/14	1													0	NA	NA	NA
12/17/14	1													0	NA	NA	NA
<b>By Species</b>	<b>39</b>	<b>9</b>	<b>43</b>	<b>17</b>	<b>19</b>	<b>31</b>	<b>0</b>	<b>12</b>	<b>53</b>	<b>54</b>	<b>0</b>	<b>277</b>					
<b>By Guild</b>	<b>91</b>			<b>17</b>	<b>19</b>	<b>43</b>			<b>107</b>								
	<b>BBSH</b>			<b>HB</b>	<b>MYSP</b>	<b>RBTB</b>			<b>UNKN</b>			<b>Total</b>					

\* 1 = Detector functioned for the entire night; 0 = Non-operational for all or part of the night