

**CIRCULATING COPY**  
**Sea Grant Depository**

LOAN COPY ONLY

# The American Oyster

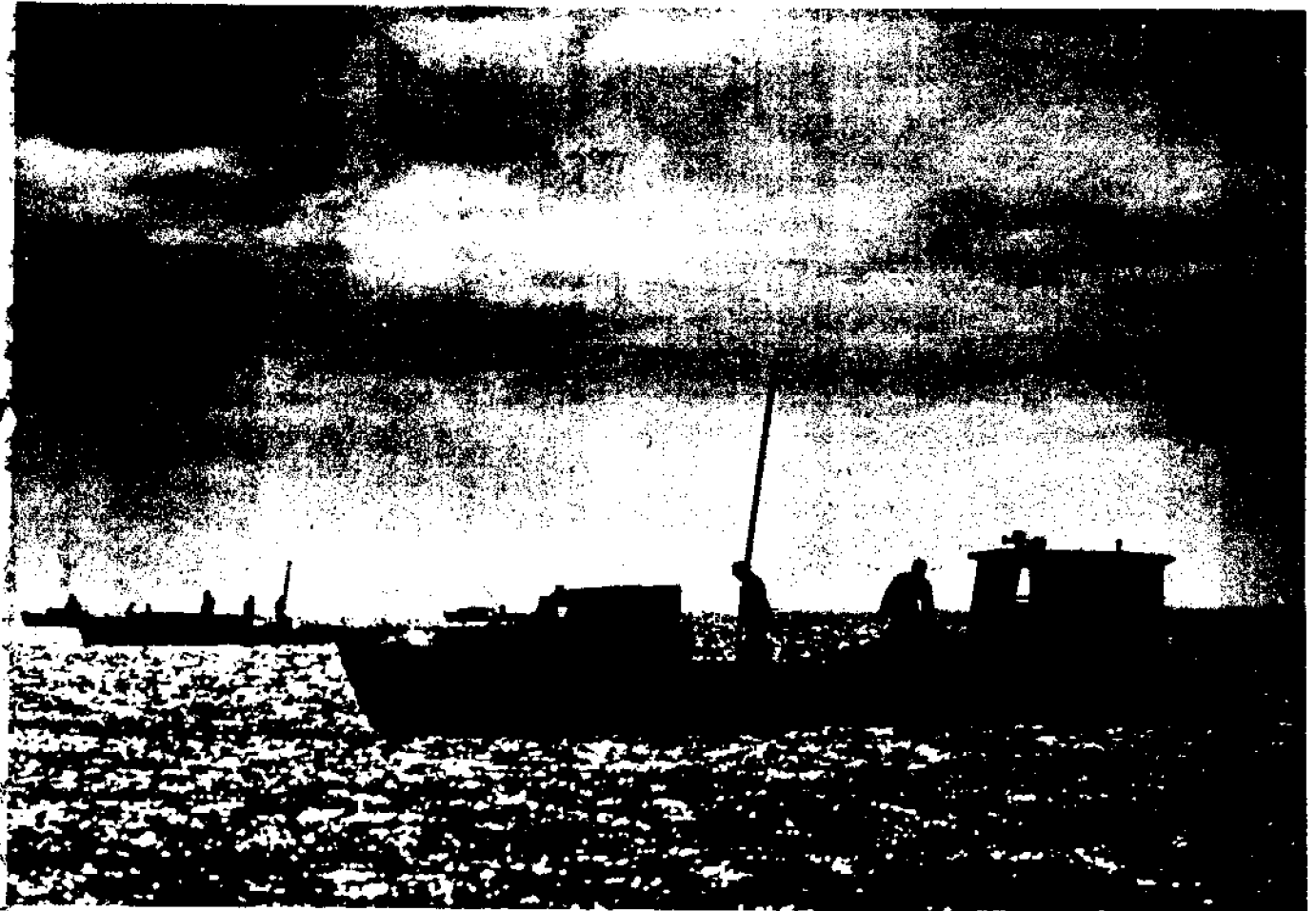

**University of Maryland Sea Grant Program**  
**Marine Science Education Project**

Publication Number  
UM-SG-ES-79-03

LOAN COPY ONLY

# The American Oyster

The Marine Science Education Project is grateful to all individuals who assisted in the development of the materials included in this publication. Special appreciation is accorded the following:

Selection and development of materials for  
The American Oyster

Nancy E. Thompson  
Science Teacher  
Thomas Johnson Junior High School  
Lanham, Maryland

Technical Assistance

Barbara B. Dunne Science Teacher G. Gardner Shugart Junior High School Hillcrest Heights, Maryland	Chris Pouler Science Teacher Eleanor Roosevelt High School Greenbelt, Maryland
----------------------------------------------------------------------------------------------------------------	--------------------------------------------------------------------------------------------

Technical Editing

J. Dewey Brown  
Science Teacher  
Wheaton High School  
Wheaton, Maryland

Project Coordinators

Jack Wheatley Associate Professor Science Teaching Center University of Maryland College Park, Maryland	Emmett Wright Assistant Professor Science Teaching Center University of Maryland College Park, Maryland
---------------------------------------------------------------------------------------------------------------------	---------------------------------------------------------------------------------------------------------------------

Sea Grant Program  
University of Maryland

Rita Colwell Director	Jack Greer Project Editor
Michael W. Fincham Communications Coordinator	Halcyon Ahearn Project Assistant

Thanks to the Johns Hopkins University Press for granting permission to use maps and drawings from The Chesapeake Bay in Maryland, edited and illustrated by Alice Jane Lippson for the Natural Resources Institute of the University of Maryland. Except for the express purposes determined for this educational unit, no part of these maps or drawings may be reproduced or transmitted in any form or by any means, electronic or mechanical, including photocopying, recording, xerography, or any information storage and retrieval system, without permission in writing from the publisher.

## INTRODUCTION

Estuaries form a fragile boundary between marine and freshwater habitats. Their value as shipping lanes, commercial fisheries, recreational areas, and breeding grounds for thousands of species of aquatic animals and plants remains incalculable. As with most estuaries, the Chesapeake Bay is suffering from overuse, its natural processes potentially changed by human manipulation. To help ensure wise handling of this valuable resource in the future, the Maryland public school system is educating the state's school population about the complex interrelationships between the Bay as an ecosystem and the Bay as a commercial, recreational and industrial commodity. In producing these curriculum materials, the goals of the Maryland Marine Science Project are to assist in this education, provide insights into those interrelationships, and encourage for the future a more informed and conscientious management of the world's most productive estuary, the Chesapeake.

The Maryland Marine Science Education Project is sponsored by the Science Teaching Center, the College of Education, and the Sea Grant Program of the University of Maryland. This cooperative effort of scientists, educators, and classroom teachers has produced a series of mini-units in marine science education for the junior high/middle school classroom. Although the curricular materials specifically treat the Chesapeake Bay, they may be adapted for use with similar estuarine systems. Teachers can also incorporate these units into their existing life science courses by using the Chesapeake Bay as a specific example of working biological principles.

Each marine science mini-unit consists of the following components:

**Teacher's Narrative**, a brief content reading for the teacher on the subject of the mini-unit;

**Student Activities**, a section containing student activities and games related to the content of the mini-unit;

**Resource Material**, a bibliography for teachers and students, a list of resource people, additional suggestions for audio-visual aids and field-trip sites, and a list of various junior high/middle school science texts where the mini-unit may be incorporated.

The Teacher's Narrative provides content material for preparing the mini-unit, and the sections on Student Activities and Resource Materials include supplementary information for developing an interesting educational unit about the Chesapeake Bay.

## **Teacher's Narrative**

## The American Oyster in the Chesapeake Bay

### Preface

This packet of information and activities pertaining to the American oyster--the most monetarily valuable crop of the Chesapeake Bay--has been prepared for the junior high program. A mini-course, it could last from three to five days, perhaps longer, involving either a single discipline or more than one. The motivation behind the preparation of this unit is to place some emphasis on the great value and importance of our marine resources. All too often we teach broad generalities without using a Maryland environment which demonstrates practical applications or examples the student can most fully appreciate.

Briefly, The American Oyster in the Chesapeake Bay contains the following information for the teacher:

- Introduction
- The Chesapeake Bay
- Historical Background
- What is an Oyster?
- Anatomy of an Oyster
- Life Cycle
- Oyster Predators and Parasites
- Oyster Distribution and Possible Reasons for Decline
- Methods of Oyster Harvest in the Chesapeake
- State Oyster Repletion Program
- Oyster Processing
- Glossary
- Student Activities Relating to the Unit
- Additional Resources and Bibliography

### Introduction

The Chesapeake Bay is one of Maryland's most valuable resources. In fact, it is the most productive estuary in the United States. A highly complex ecosystem, the Bay is also very fragile. Recent urban development has placed increasing strain on the Bay's water quality. A new shopping center means more runoff of rainwater into a tributary of the Bay--runoff that picks up soil particles, oil, pesticides, fertilizers, and many other pollutants. More time for leisure activities has resulted in greater demand for Bay-side properties and marinas, resulting in the draining of valuable marshland and the introduction of additional pollutants.

Oysters, crabs, and rockfish from the Chesapeake Bay have ensured the livelihood of many citizens and have provided food famous the world over for its delicious, unique flavor. Now these crops are being threatened because of pollution and mismanagement caused by man. In this particular mini-course, it is planned for your students to gain an interest in the consequences of man's actions toward a natural system. As a specific case study, the life cycle of the oyster will be outlined, as

will a discussion of some of the possible causes for the continuing decline in Bay oyster production. This information will be followed by a series of class activities that should reinforce much of the information. Finally, a resource list will indicate where further information may be found.

### The Chesapeake Bay

The Chesapeake Bay is the largest estuary in the United States and one of the most productive in the world (see Figure 1). An estuary is a unique body of water which is coastal but partially enclosed. Since it is open to the sea, salt water is free to mix with fresh water draining from the land. The salt content of the water--the salinity--decreases from the mouth of the Bay at Norfolk to its headwaters at the Susquehanna River, falling gradually from 29 parts per thousand to 0 parts per thousand. Salinity is the number of parts of salt per thousand parts of water, abbreviated as "ppt." The gradual decrease in salinity as one moves up the Bay has created a unique environment to which Bay organisms have adapted their life cycles. The American oyster, *Crassostrea virginica*, is the single-most valuable commercial species growing in the Chesapeake Bay. About 27 percent of the United States' oyster harvest comes from the Chesapeake Bay. It provides more money to its commercial fishermen than any other species--\$16,000,000 in 1971, as opposed to \$7,000,000 for the blue crab, the second-most valuable species. (See Figure 2.)

### Historical Background

The East Coast oyster, or American oyster, is considered one of the tastiest in the world. It is found along the coastline from Canada southward to Florida and around the Gulf of Mexico as far as the Yucatan Peninsula. It is not found in the ocean, however, but only in estuarine waters. The only other member of the genus *Crassostrea* found in this country is the West Coast oyster, *Crassostrea gigas*, which was originally imported from Japan. Oysters have been used as food since prehistoric times. In the Chesapeake Bay area Indians ate them for several thousand years before European colonization. Evidence for this is the large piles of shells or "middens" left by the Indians. Chinese history records the use of oysters as far back as 3000 B.C., and the Italians cultivated them as early as 50 B.C. In fact, for several thousand years, oysters have been the number one example of mariculture or aquaculture--farming of the sea.

### What Is an Oyster?

The oyster is a bivalve mollusk (also spelled mollusc), meaning a soft, unsegmented animal enclosed in two hinged shells. There are over 400 different species of mollusks called oysters worldwide, including the non-food-producing pearl oyster. Over 70 of the 400 species are edible, but only a few of these are grown commercially. Immobile once adult, the oyster is a benthic or bottom-dwelling animal. The bottom must be firm and above the silt. The oyster feeds upon plankton, one-celled plants and animals which the oyster strains from water pumped through its gills. This method of feeding has caused the oyster to be known as a "filter



feeder." An average oyster, 7 cm or larger, feeding at temperatures of 10°C (50°F) or higher, will filter approximately 180 liters (50 gallons) of water a day to get food and oxygen.

An active bed of oysters will maintain a circulation of water over the bed, which prevents silt from settling and covering the oysters. Filter feeding will tend to concentrate small organisms in an oyster's body, including pathogenic (harmful) bacteria such as certain coliform (intestinal) types which are normally found in sewage. For this reason, sewage effluent dumped into an estuary may raise the coliform level to the point that oyster beds must be closed to fishing. After hurricane Agnes hit in June, 1972, oyster fishing was suspended because of the concentration of coliform bacteria in the oysters. This increased concentration of bacteria was caused by excessive runoff, including sewage-line overflows into the Bay.

#### Anatomy of the Oyster

The oyster is a bivalve mollusk, meaning its body is enclosed by two valves, or shells, joined at the narrow end by a hinge. The two valves are not symmetrical. The valve in which the oyster lies is larger, deeper, and thicker than the other valve, which acts as a lid. During dissection, the flat, lid-like valve, designated the "right valve," is usually removed and the animal is studied as it lies inside the left valve. Refer to Figure 3 for the discussion following.

Underneath the valve, the body of the oyster is covered with a soft membrane called the mantle. Along the edge of the mantle are tentacles, used for sensing the environment. The unattached parts of the mantle enclose a large space filled with sea water and known as the mantle cavity. The sea water is known as shell liquor. The shell liquor enables the oyster to survive several days' exposure to air or to survive temporary unfavorable conditions caused by flooding or pollutants. The primary function of the mantle is secretion of the shell. It also controls the flow of water for respiration and feeding. The color of the surface mantle facing the shell varies with conditions. Lean oysters with no glycogen (stored animal carbohydrate) are usually a dull grayish color, while "fat" oysters are white, and those about to spawn are creamy yellow.

The gills lie directly under the mantle along the entire non-attached edges of the shell. The gills not only function in respiration, but in collecting and sorting food as well.

The mouth is located at the top or hinged part of the oyster. It is covered by lips or palps which help to direct food into it.

Almost directly connected to the palps is the stomach which lies above the heart and adductor muscle. The digestive system includes a stomach, digestive gland, and intestine. All waste materials and sexual products are secreted into a common canal formed by the joining of the gills and mantle. The gills and mantle act together to expel forcefully these materials from the oyster.

The three-chambered heart lies between the stomach and the adductor muscle. It pumps blood through simple branching vessels in the oyster's body. The blood carries food and oxygen to all parts of the oyster and removes waste material from it.

When opened, the most conspicuous part of the oyster is the adductor muscle, situated near the middle of the body. This powerful muscle is used to hold the valves together.

Gonads, or sex organs, are usually not visible. When the organism is sexually mature they may be seen near the hinged area overlying the stomach.

Since the oyster has no eyes, ears, or nose, it cannot see, hear, or smell. However, the tenacles edging the mantle are sensitive to changes in light and to changes in chemicals in the water. The tentacles overhang the edge of the opened shell and respond to stimuli by contracting, which in turn causes the adductor muscle to contract, closing the shell. The nervous system consists of cerebral ganglia, or nerves, at the base of the labial palps which connect to the visceral ganglia located below the adductor muscle. These ganglia help to coordinate the oyster's organ systems. The oyster is a very primitive animal which has been successful for ages, relying on the cooperation of its organ systems rather than on the dominance of any one system.

The parts that are labeled in Figure 3 are the ones which can be fairly easily seen and located in an opened oyster. The ganglia, the gonads, and the intestine are much harder to detect in a simple dissection.

#### Life Cycle

The American oyster has separate sexes, although a very few oysters are hemaphrodites, having both sexes in one animal. Most American oysters begin life as males and change to females as they get older. Through the cold winter months oysters remain dormant, living on glycogen--a carbohydrate usually found in the liver of vertebrates--which has been stored in their bodies during the summer and fall. In the spring, as Bay water temperature rises to 10°C, the oysters become active, feeding and repairing shell damage. With the continued increase in water temperature, gonadal development begins, and spawning--the release of eggs or sperm--occurs at temperatures above 20°C (68°F).

Gregarious creatures, oysters grow best in close proximity to one another. (Refer to Figure 4 for the following discussion.) The emission of sperm from one oyster triggers the release of eggs and sperm from surrounding oysters. The sperm cells fertilize the egg, which hatches in one or two days into a free-swimming larval oyster called a veliger. The veliger feeds voraciously on plankton for two to four weeks. By the time it is ready to settle or attach it is said to be in the umbo\* stage and has developed enough to resemble a small oyster, although only the size

---

\*The umbo is the oldest part of the shell, and it becomes the bump where the valves hinge together.

of a pinhead. It swims over a clean, hard surface, such as an oyster shell, seeking a place to settle. Once it settles it glues itself in place by a cement secreted from a gland. After the larval form has settled and attached, it is known as a spat or seed-oyster.

The act of setting is known as spat set. The free-swimming, planktonic larval stage is highly vulnerable to many ecological factors: temperature, salinity, food availability, and pollutants, as well as threats from many predators. Of the four to five million eggs a mature female may emit in one season in open waters, only about 10 to 15 of these eggs will ever reach maturity.

Spat feed voraciously in their first year of life and may experience tremendous growth. Under controlled optimal conditions oysters have grown to 7.62 cm or three inches in one year; however, the average growth rate on natural bars is about 2.54 cm or one inch a year. Since the minimum legal size in Maryland is 7.62 cm or three inches in length, harvesting age is usually three years. Their most active growth period is the first five years of life, followed by growth at a much slower rate. There have been records of oysters living as long as 20 years in a laboratory. Most Chesapeake Bay oysters reach sexual maturity by their second year of life. Containing both sex organs, the oyster usually develops first as a male. By the next year enough oysters from the same hatch have changed into females to have an approximate 1:1 male to female ratio. The oyster is capable of changing sex several times in a lifetime. Environmental factors have an effect on the sex change; fast-growing, large, or old oysters tend to be female, whereas weakened or injured individuals tend to be males.

An interesting note may be interjected here. According to scientists at Horn Point Environmental Laboratories (Cambridge, MD), one of the University of Maryland's Center for Environmental and Estuarine Research labs, oysters exhibit sexual behavior prior to spawning. For people observing closely, oysters about to spawn will exhibit behavior peculiar to the sex the oyster happens to be at that time. Males are reported to rock back and forth just prior to shooting a stream of sperm out at the end of the shell, while females clap the shells open and closed a couple of times and release the eggs at about the middle of the shell.

#### Oyster Predators and Parasites

Spat set and resulting recruitment are higher in higher salinity waters (15-29 ppt), and the resulting growth is faster and more constant, resulting in better meat quality. However, the incidence of oyster predators and parasites is also much higher in higher salinity waters.

#### Predators

The boring sponge, *Cliona* sp., although found in wide areas of the Bay, has a greater effect upon adult oysters in areas of higher salinity. The larval stage of the sponge settles on the oyster shell and bores into it for shelter. Although the sponge uses the burrow for shelter only,

its burrowings weaken the shell, causing it to break. If the sponge penetrates to the mantle cavity, it kills the oyster.

Oyster drills or screwborers, *Urosalpinx cinerea* and *Eupleura caudata*, are small mollusks one-half to one inch, or 1.27 cm to 2.54 cm in diameter (see Figure 5). These snails prey upon the oyster by boring small round pinholes into its shell and then consuming the oyster through these holes. Drills are serious problems only in the saltiest parts of the Bay, such as lower Tangier and Pocomoke Sounds, and in Chincoteague Bay. In dry years, when Bay salinity increases, the drills become a wider-spread problem, being limited by a mean salinity of no less than 15 ppt. *Eupleura* has a greater demand for salinity and therefore a narrower range; it is not found in water less than 20 ppt, whereas *Urosalpinx* can tolerate water no less than 18 ppt. (See Figure 5.)

The flatworm can be found throughout the Bay but is more abundant in southern areas. It preys by making a small hole in the edge of the shell through which it can enter and devour the oyster.

Blue crabs are major predators of the very young spat. Large blue crabs readily crush and feed on young, thin-shelled spat.

#### Parasites

Two microscopic parasites are responsible for two major diseases of oysters in the Chesapeake Bay.

MSX (*Minchinia nelsoni*), a microscopic protozoan, parasitizes oysters in the saltier regions of the Bay. In the late 1950's to early 1960's it seriously reduced oyster population in Pocomoke and Tangier Sounds.

Although not harmful to humans, oysters infected with MSX suffer initial damage to the gills and filtering organs and final massive cell damage and tissue breakdown resulting in death.

Dermo, *Labyrinthomyxa marinum*, is a fungus parasite of oysters under crowded conditions. This fungus favors high temperatures and salinity. Although not harmful to humans, Dermo-infested oysters suffer extensive breakdown of connective tissues. Younger oysters do not appear to be as seriously affected as older ones. A problem in the 1950's, Dermo has reappeared to cause mortalities of as much as 55 percent per year on certain oyster bars.

#### Oyster Distribution and Possible Reasons for Decline

The oyster is widespread throughout the Bay, even in the saltier rivers and streams; however, the oyster requires a minimum salinity of 7 to 8 ppt. (See Figure 7.) The oyster can tolerate full ocean salinity (about 29 ppt), but is found there less and less because predators, parasites, and competitors are limited to higher salinity waters (15-29 ppt). Oysters are bottom or benthic (*benthos* is Greek for bottom) dwellers and therefore require solid bottoms to prevent sinking and smothering.

Often oysters are found attached to shells, stones, other live oysters, or any hard object. Increasing siltation due to runoff and erosion from shopping centers, construction sites, and farms may be one factor causing oyster decline due to smothering. Oysters are subtidal--found below the low tide line--and most are found at depths of 2.5 to 7.6 meters (8 to 25 feet). Since dissolved oxygen availability varies with the season, oysters are usually not found in waters over 10.6 meters (35 feet) deep.

The oyster has been an economically important shellfish in the Middle Atlantic States since the 1700's. However, for the past 100 years the oyster harvest in the Chesapeake Bay has undergone a continual decline, and in recent years there has been a dramatic drop in productivity due to declining population numbers throughout the Bay. Several theories prevail concerning the fall in oyster populations. Some of the factors which might be causing the decline are: failure of adults to spawn, abnormal embryonic or larval development, starvation of larval stages due to improper or inadequate phytoplankton communities, unusually high rates of predation during the larval phase, or failure to settle and metamorphose successfully.

The degree of successful oyster spawning, setting, and survival as small oysters or spat, known as natural recruitment, varies greatly in the different oyster habitats of the Bay. Some areas have such low reproductive capacity that harvesting would wipe out the population unless artificial "seeding" of spat were practiced.

With good management, other areas remain productive; and finally some areas are so productive that surplus spat may be transplanted to low production areas.

Poor spat-setting areas have several characteristics in common. Areas with salinities in the lower range of tolerance for the oyster have low spat set; these areas have a large drainage basin with a high rate of water turnover, leading to great changes in water quality--turbidity, temperature, nutrient supply, and pollutants--all of which can be fatal to the delicate, waterborn larval stage.

Good spat-setting areas are characterized by middle to high salinities, relatively good water quality (no sewage or industrial pollution), and a stable water mass with tidal fluctuations alone, rather than surface runoff of water to move the larvae. These conditions are best provided on the central Eastern Shore of the Bay and the oyster industry is concentrated there. Since the "County Boundary" law, which limited watermen to fishing in their home counties, was lifted, watermen from all over Maryland are overfishing the area.

A further threat to the industry was the May 1977 Supreme Court decision, *Douglas vs. Seacoast Products, Inc.*, ruling residency laws illegal, meaning that Virginia oystermen could fish Maryland's bars and vice versa. These bars have been partially maintained by the spreading of cultch (clean oyster shells) and seeding with spats, and by transplanting healthy oysters from polluted areas to favorable areas. These

practices are paid for by a tax on Maryland oystermen. It is feared the Supreme Court decision may have further detrimental effects on the oyster crop other than overfishing. Maryland oystermen may no longer be willing to pay the tax per bushel which has supported oyster seeding when they know their Virginia counterparts may fish the bars for nothing. For the oyster industry to continue to be an important economic asset to Maryland's economy, natural recruitment must exceed or at least keep pace with the harvest. Natural recruitment and oyster production in Maryland waters has shown a downward trend over the past 100 years.

In summary, there are several theories popular today to explain the decline of the American oyster in the Chesapeake Bay. Increasing siltation and pollution and decreasing salinity are all related to man's activities. The clearing of land for development and the paving of vast areas cause silt, or tiny suspended particles of soil, to increase in the Bay. These particles settle over the oysters, smothering them. Paved land cannot absorb runoff from rainfall. This freshwater runoff tends to lower the salinity of the upper Bay and to carry more pollutants into the Bay, thereby restricting oyster growth. These three factors reduce oyster populations directly and indirectly. Indirectly, these factors affect oysters by decreasing the phytoplankton. Phytoplankton are the microscopic plants which serve as the oyster's food. Suspended silt cuts down on the sunlight needed by the phytoplankton for photosynthesis or food production. Less phytoplankton results in oyster starvation. Overfishing and improper conservation practices also contribute to oyster decline. Certain pollutants could also directly affect embryonic development, causing development to be abnormal.

#### Methods of Oyster Harvest in the Chesapeake

Methods for harvesting oysters in the Chesapeake have undergone little change since the days in which all commercial fishing was done under sail. Today there are more commercial sailing craft in the Maryland waters of the Bay than in any other bodies of water in the country. The reason for this is a Maryland law passed in 1865 which prohibited the use of steam motive power in dredging oysters. The law was passed to conserve the oyster supply, but it has also helped to preserve a way of life unique to the watermen of the Bay. Proud of their ability to withstand the rigors of the weather, the hard manual work, and the unpredictability of the catch, Maryland watermen persist in a method of harvesting oysters that lasts several months under cruel winter conditions. Using modern equipment, they could harvest the same amount of oysters in a one- or two-week time period. But they persistently choose not to. Not to see skipjacks under sail working the oyster bars, or tongers working the bars with hand tongs, would be a loss far greater than the monetary loss. If this happens much of the beauty and lore of the Chesapeake will disappear. It would be an esthetic loss, a loss of appreciation for man and nature in close harmony, interacting without exploiting.

Three principal methods are used: hand tongs, oyster dredge, and patent tongs (see Figure 8). Hand-tonging for oysters is without a doubt the hardest job in Bay country. Drawing on great physical

strength, the tonger stands on the deck of a bobbing boat and operates his tongs, which resemble two long rakes. Moving them back and forth, scissor-like, over the oyster bar, he rakes up oysters which are held in the closed tongs until they are brought into the boat. Hand tongs are the only device permitted on public beds in most tributaries and in some parts of the Chesapeake Bay.

An oyster dredge is a steel bar with teeth and a frame holding a bag. When the dredge is dragged over a bar the teeth rake up the oysters, which are then caught in the bag. The dredge can be used under sail only, and then in only certain areas of the Bay and two of its larger tributaries. A power winch may be used now to lift the dredge. A pushboat is a small, motor-powered boat carried by the skipjack or sailboat. It may be lowered two days a week and used to push the skipjack across the oyster bar as it dredges.

Patent tongs are an enlarged version of hand tongs and gather oysters in the same manner, but are operated by a hydraulic lift on shipboard. The boat carrying the patent tongs is motor-driven to the bed; but once there, it must remain stationary during the tonging operation. Two patent tongs, one on either side of the boat, may operate simultaneously.

#### State Oyster Repletion Program

In order to protect the oyster crop, Maryland has had an oyster repletion program. Cultch--clean oyster shells--are spread on public oyster bars and self-sustaining natural bars to provide surface for spat set. Young spat that have set on cultch in non-productive areas are moved to productive areas for further growth. In order to have enough shells for cultch, the State buys all the fresh shells which are available from the shucking houses each year. When oysters leave Maryland in the shell, the shells are lost to the State. Further taxes include a 5¢ inspection tax on all oysters and a 20¢ tax on oysters from public bars. These various taxes and licensing fees help to sustain the State Oyster Repletion Program.

#### Oyster Processing

Oyster processing has traditionally involved hand-shucking, which is fast becoming a vanishing art. Hand-shucking is a tedious, difficult job, especially when speed must be worked into the operation. Crab-picking and oyster-shucking are piecework, which means that the person is paid for the amount of meat separated from the shells, not by the hour. If a person is to make a decent wage, he or she must be fast. Hand-shucking involves washing the oyster, inserting a sharp knife between its shells to sever the strong adductor muscle that holds them together, breaking open the shells, and scooping out the body.

The number of people who are able or willing to do this in Maryland has declined to the point that two out of every three Maryland oysters are now shucked in Virginia by Virginia shuckers. The Virginia shuckers are available now because the Virginia oyster crop was decimated by

a Dermo-like disease during the late 1960's. If these beds recover as experts predict, Virginia shuckers will be busy with their own oysters. People concerned about this problem, such as members of the Chesapeake Bay Seafood Industry Association, have been trying for years to persuade federal agencies to start manpower training programs. These requests have been denied repeatedly on the ground that seafood processing is a job that "lacks upward mobility." Oyster shucking may lack upward mobility, but wages of \$10.00 to \$16.00 per hour for an average to a good shucker have been reported--excellent money for seasonal work.

One possible solution is the development of mechanical shucking. One such mechanized method is the "heat-and-shake" method, being used in Campbell's oyster stew plants in Virginia. Oysters are sent through a large oven that heats their shells enough to relax the adductor muscle. They are bounced through a large tumbler that shakes the meat from the loosened shells. Since the meat is only partially cooked, it must be processed further. There is no chance that it can be packed as fresh, raw, succulent oyster. New products must therefore be developed, as well as new markets. These products might be oyster pot pies, oyster cocktails, frozen, breaded oysters, or prepared oyster stuffing.

Because of ecological stress on the Chesapeake Bay, the oyster may face severe problems finding appropriate places to set, clean, unclouded water in which to grow; and abundant marine organisms on which to feed. The Maryland oyster industry also faces problems, with harvesting, processing, and marketing--and, of course, all this depends on the abundance of the oyster itself. Solutions to all these problems will come from many different interests; the marine biologist, the waterman, the food processor, the distributor, the concerned citizen who supports the preservation of the Chesapeake Bay, all will play a part. And there will continue to be many opportunities for young people to deal with these problems in interesting and challenging careers.



FIGURE 1

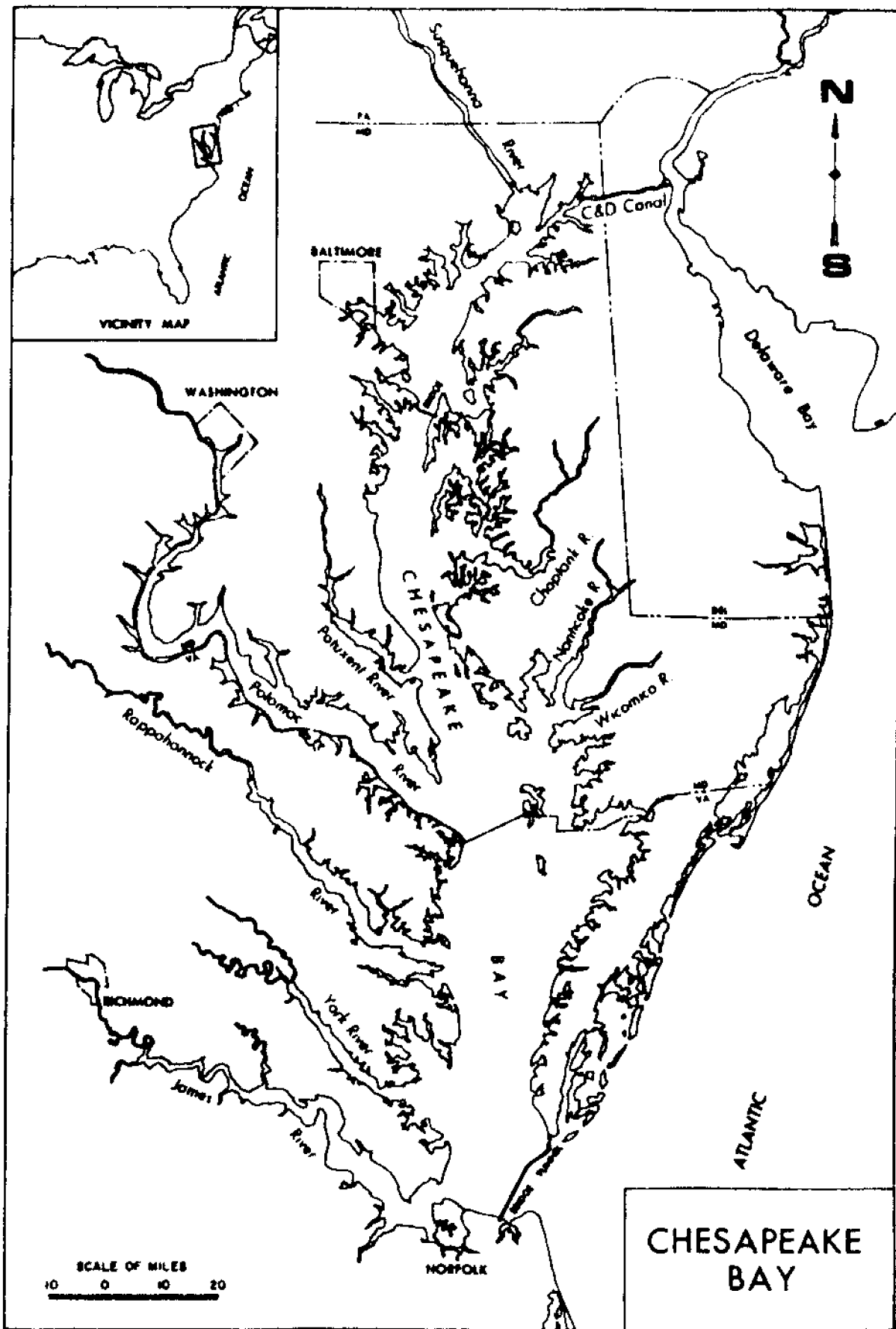

FIGURE 2

Bay Harvest

L. Eugene Cronin, Director of the Chesapeake Research Consortium, Inc. and an authority on the Bay, estimates that half a billion pounds of seafood is currently harvested from the Chesapeake annually. Commercial landings for 1971:

	Maryland		Virginia	
	Pounds	Dollars	Pounds	Dollars
Finfish	16,174,343	\$ 1,714,800	50,596,176	\$3,049,559
including:				
Menhaden	5,957,567	119,294	18,520,644	213,297
Striped Bass	2,743,007	861,892	1,183,356	280,140
Bluefish	140,981	14,991	610,970	61,572
Flounder	313,695	102,998	1,780,352	524,169
Shad	946,631	123,020		
White Perch	1,507,706	240,144		
Blue Crabs	27,605,979	3,201,463	48,440,541	4,008,422
Hard Clam Meats	332,131	192,089	1,836,544	1,397,837
Soft Clam Meats	5,986,120	2,993,064		
Surf Clam Meats	7,751,436	980,736	4,506,622	526,715
Oyster Meats	17,131,100	10,693,640	8,322,608	5,341,321

From Understanding the Chesapeake by Arthur W. Sherwood.

FIGURE 3

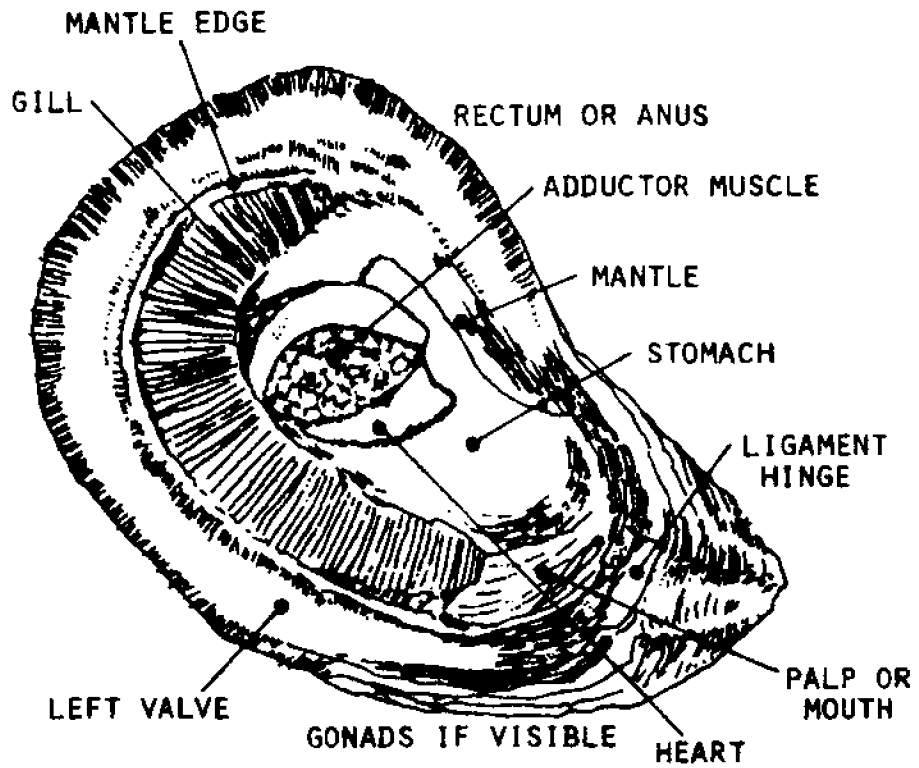

## **Anatomy of an Oyster**

From The Maryland Oyster, Fred W. Sieling

**FIGURE 4**  
**Life Cycle**

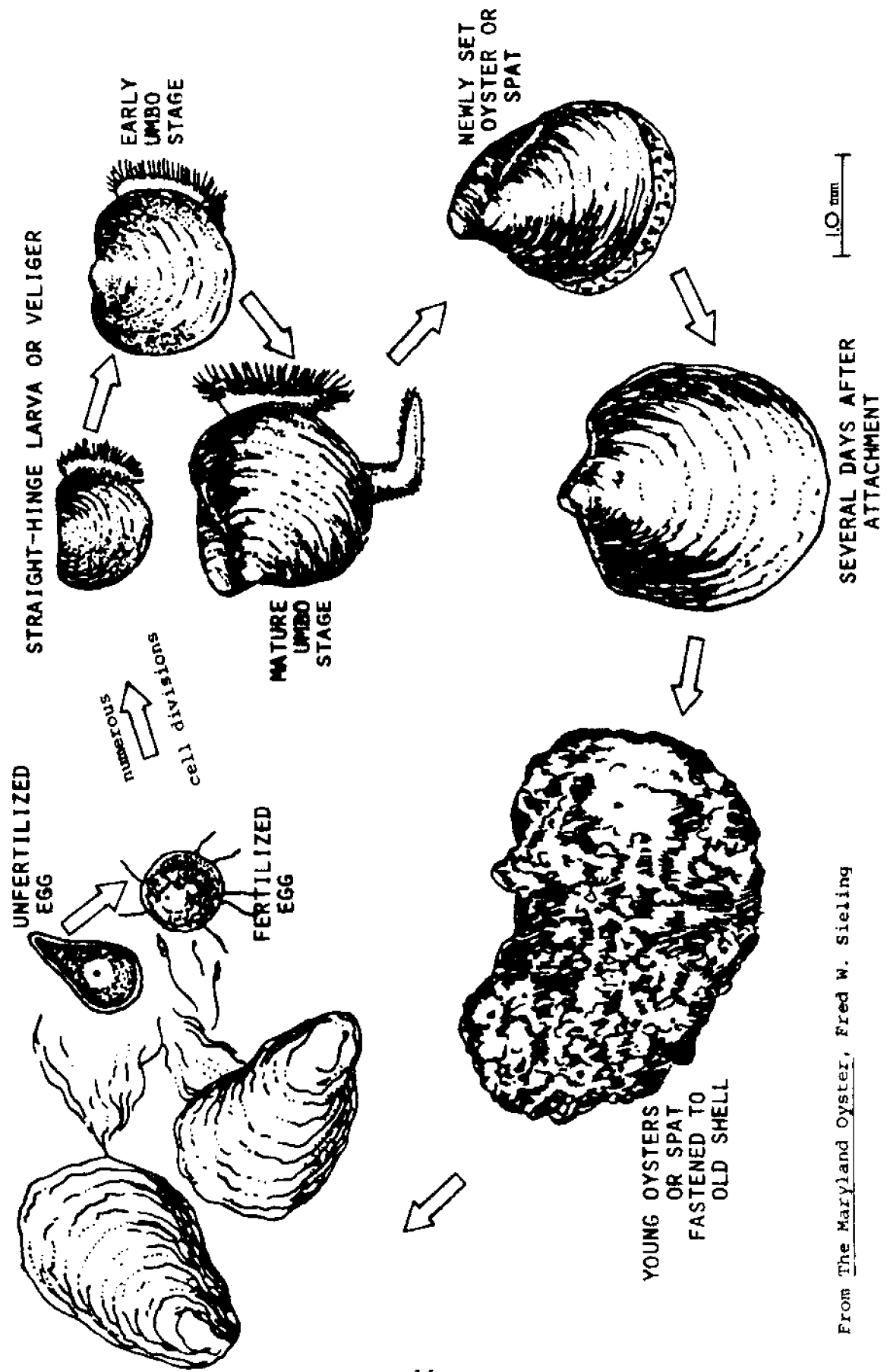

From The Maryland Oyster, Fred W. Sieling

FIGURE 5

Oyster Drills or Screwborers

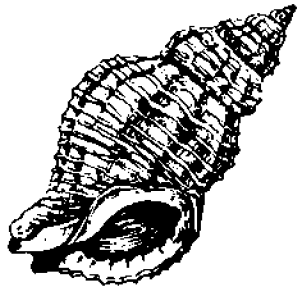

*Urosalpinx cinerea*



*eupleura caudata*

# Oyster Predators

Drawing by Alice Jane Lippson, The Chesapeake Bay in Maryland

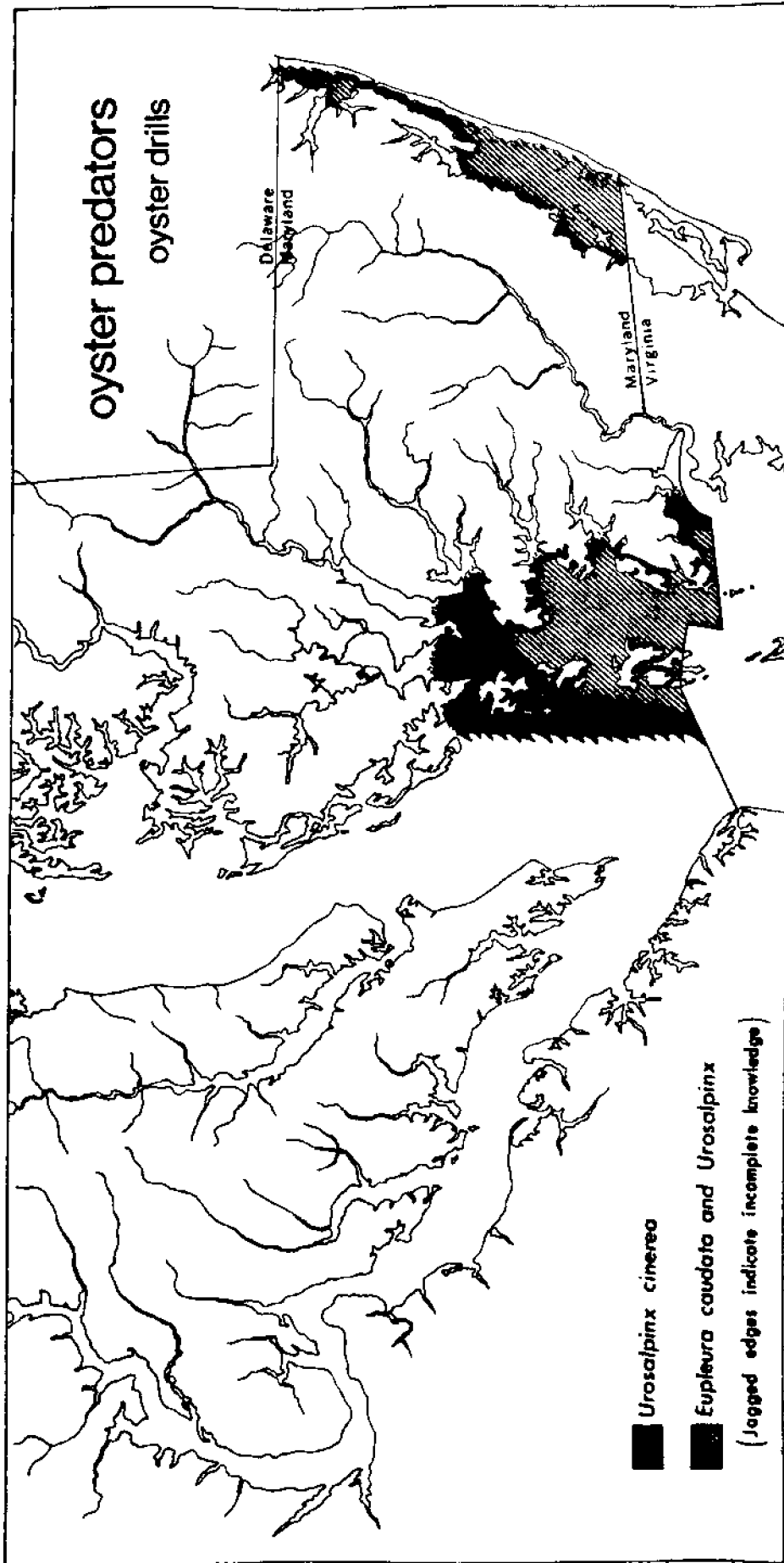

Drawing by Alice Jane Lippson,  
The Chesapeake Bay in Maryland

FIGURE 6

FIGURE 7

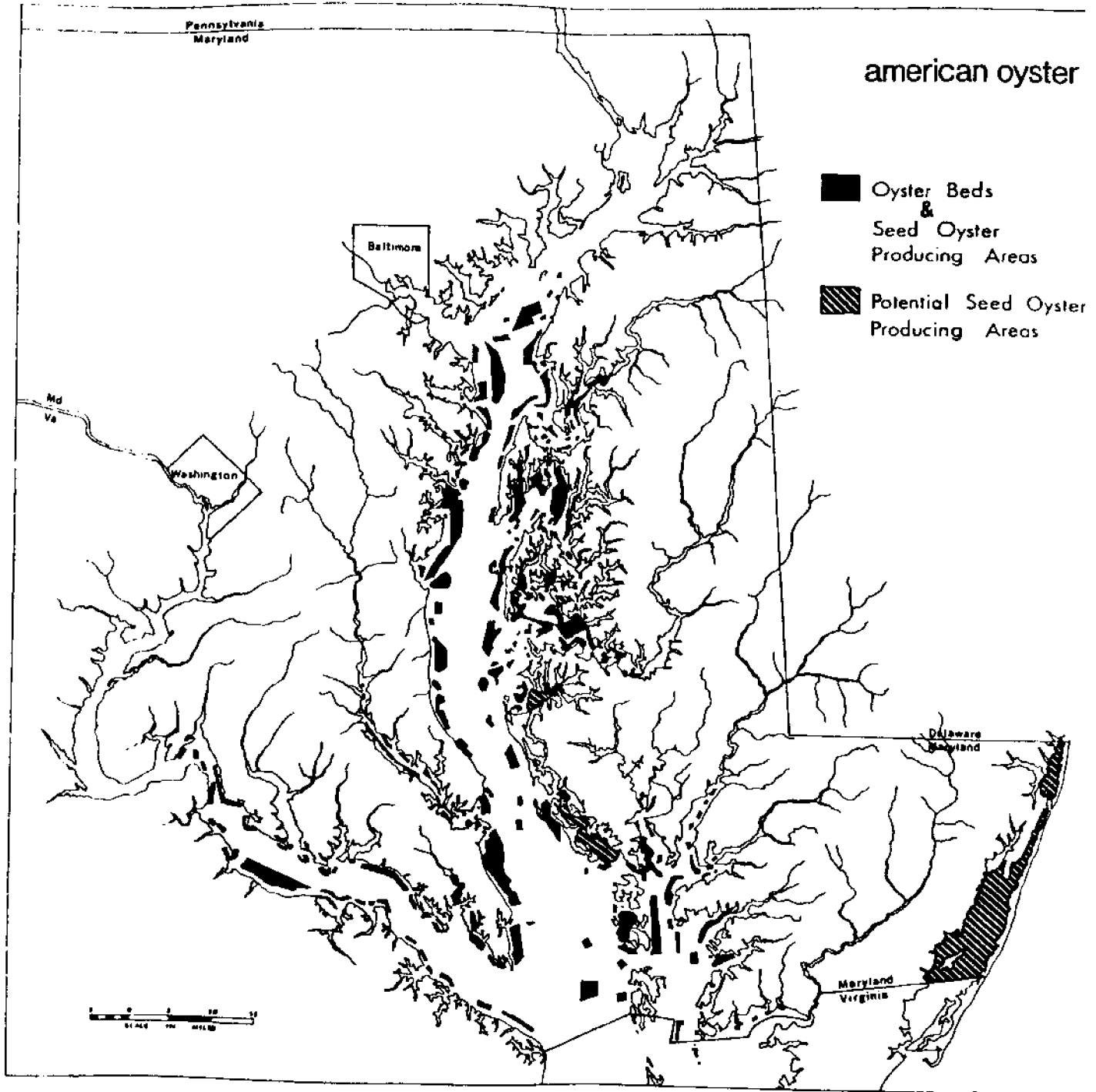

Drawing by Alice Jane Lippson, The Chesapeake Bay in Maryland

FIGURE 8

# Oyster Harvesting Equipment

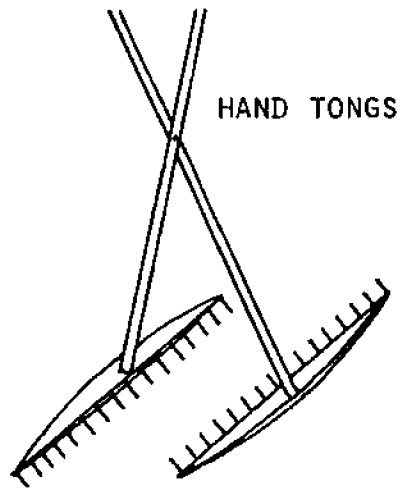

HAND TONGS

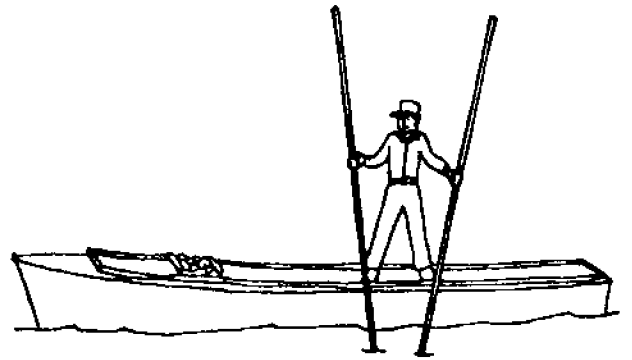

HAND TONGER

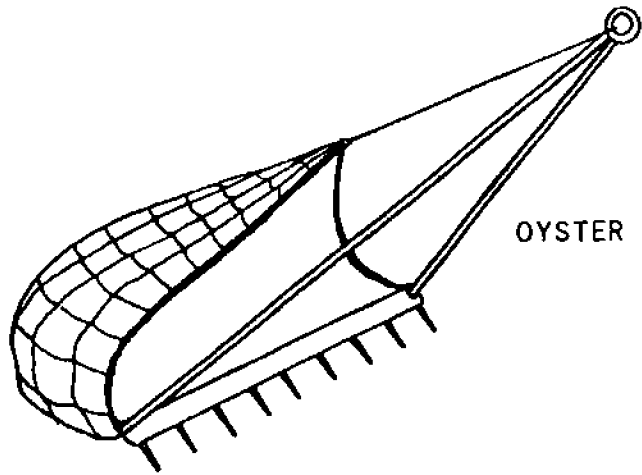

OYSTER DREDGE

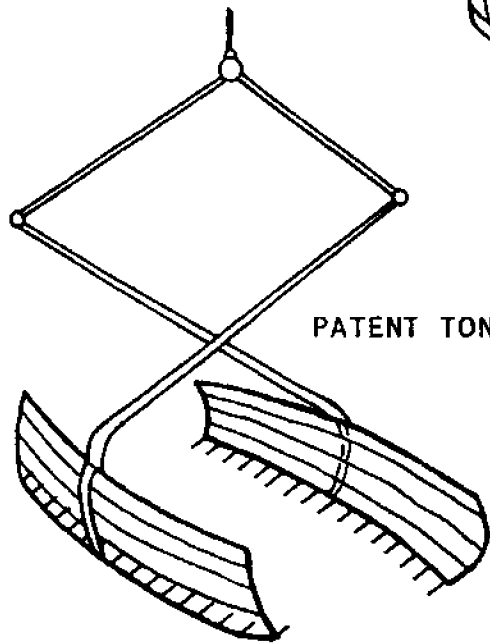

PATENT TONGS

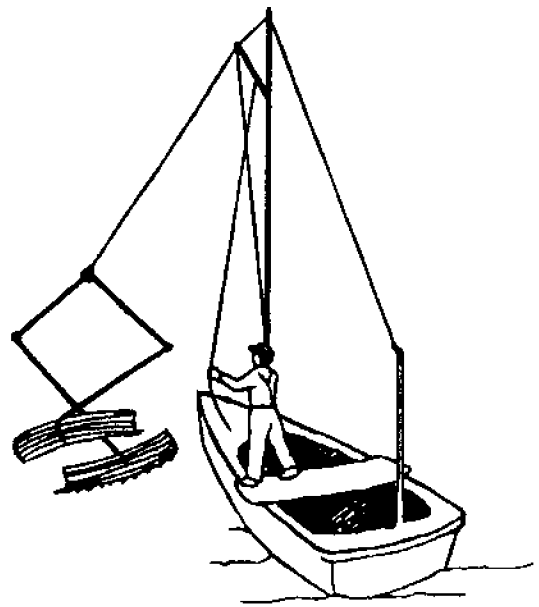

PATENT TONGER



## GLOSSARY

1. Aquaculture - Farming in the water (Mariculture or Aquiculture).
2. Benthic - Found on the bottom.
3. Bivalve - A mollusk with two shells (clam, oyster, mussel).
4. Coliform - A type of bacteria that may be found in the human colon and is passed into sewage. Its presence may indicate sewage pollution.
5. Competitor - An organism which, either by occupying the same habitat or eating the same diet, competes with another organism.
6. Cultch - Material, usually shell pieces, to which oyster spat attach.
7. Dermo - A fungus parasite of oysters which can be fatal to them.
8. Dissolved oxygen - The amount of oxygen dissolved in water and available to gill breathers. Expressed in milligrams per liter, (mg/l).
9. Dredge - A device for gathering oysters consisting of a bar with teeth followed by a basket into which the oysters fall as it's dragged across a bed.
10. Effluent - The runoff or outflow of liquid from a system.
11. Estuary - A partially enclosed coastal body of water in which fresh water is mixed with salt water.
12. Filter feeder - An organism that feeds by drawing water into its body, filtering out the microscopic organisms for food.
13. Fungus - A microscopic plant which does not have chlorophyll and therefore cannot manufacture its own food but must feed on other organisms.
14. Glycogen - A chief animal storage carbohydrate found normally in the liver.
15. Gonadal - Pertaining to the reproductive or sex organs.
16. Gregarious - Living close together in a group.
17. Hermaphrodite - Having both sex organs in the same individual.
18. Mariculture - Farming of the sea (Aquaculture, Aquiculture).

19. Metamorphose - To change form.
20. Middens - A refuse heap, piles of oyster shells left by Indians centuries ago around the Bay.
21. Mollusk - Invertebrate animal with a soft, unsegmented body enclosed in a shell.
22. MSX - A microscopic protozoan, Minchinia nelsoni, which parasitizes oysters, and can cause their death.
23. Parasite - An organism, plant or animal, which derives its nourishment from another organism.
24. Patent tong - Large tongs, hinged grasping devices, which are operated by hydraulic equipment.
25. Pathogenic - Disease causing.
26. Pelagic - Found in the open sea, oceanic.
27. Plankton - Microscopic plant and animal life which floats or drifts in water.
28. Predator - An organism that kills and feeds on another organism.
29. Protozoan - A one-celled animal.
30. Recruitment - Spat set and resulting growth of a young oyster to the point that it can replace an oyster taken from the Bay.
31. Salinity - The amount of salt in water, expressed in parts of salt per thousand parts water, 0/00.
32. Seed - Young oysters.
33. Shellfish - An aquatic invertebrate with a shell, an edible mollusk.
34. Shuck/Shucker - The act of opening the oyster and removing the meat from the shell; one who does this process.
35. Silt/Siltation - Tiny suspended soil particles washed into a body of water; the act of filling in with silt.
36. Skipjack - A sailing vessel, used in harvesting oysters.
37. Spat - A newly settled or attached oyster.
38. Spatfall/ Spat set - The act of attachment by the larval oyster; once attached it is known as a spat.

39. Spawning - The act of releasing eggs.
40. Subtidal - Below the low tide line so that there is no exposure by tides.
41. Tong - A long-handled, hinged grasping device used for gathering oysters by hand.
42. Tributary - A stream or river feeding into a larger body of water.
43. Turbidity - The presence of suspended solids in water, "muddiness."
44. Umbo - The bumps or beak-like projections which represent the oldest part of a bivalve shell.
45. Veliger - Free-swimming larval oyster.

# **Student Activities**

## STUDENT ACTIVITIES RELATING TO THE UNIT

The following student activities have been developed to reinforce learning in this unit:

1. Graph Interpretation--Production of Oysters in the Chesapeake Bay and in the U.S. 1880-1975
2. Map Reading Activity (Five maps)
3. What's in a Name? Teaching Scientific Classification.
4. Let's Make Oyster Stew.
5. Name That Part--Oyster Dissection.
6. Oyster Rummy--Game for Vocabulary.
7. Benthic Bingo--Game for Vocabulary.
8. Oyster Fun--Word Search for Vocabulary.

NOTE:

Activities vary in difficulty. Activity 2 (map reading), for example, ranges from the easy--2(a)--to the difficult--2(b). Some students may find the questions on predators' toleration of salinity too hard.

## GRAPH INTERPRETATION

Production of oysters in Chesapeake Bay and in the U.S. 1880-1975.

Activity:

Look at the graph on oyster production and answer the following questions.

1. What is the largest amount in millions of pounds of oyster meat that was harvested in a single year? Write this amount in a numerical figure. \_\_\_\_\_  
Is this answer for the U.S. or for the Chesapeake Bay? \_\_\_\_\_
2. Using a straight edge held even or parallel to the bottom or horizontal axis of the graph, what is the smallest amount in millions of pounds harvested in one year? \_\_\_\_\_  
Was this in the Bay or the U.S.? \_\_\_\_\_  
What year did this occur? \_\_\_\_\_
3. Would you say oyster production is on the increase (going up) or on the decrease (going down) since 1880? \_\_\_\_\_
4. Using a straight edge held even or parallel to the side or vertical axis of the graph, at about what year in the twentieth century did oyster production in the U.S. show a dramatic or sharp increase? (the largest single increase on the graph) \_\_\_\_\_
5. What was the amount in millions of pounds of oyster meat produced in the Chesapeake Bay in 1975? \_\_\_\_\_  
Does this appear to be more or less than in 1970? \_\_\_\_\_

\*\*\*\*\*BONUS QUESTION\*\*\*\*\*

If we read the 1970 oyster production figure for the U.S. as 50 million pounds, how many tons was that? (A ton is 2,000 pounds.)

\_\_\_\_\_

Show your work.

MILLIONS of POUNDS of MEATS

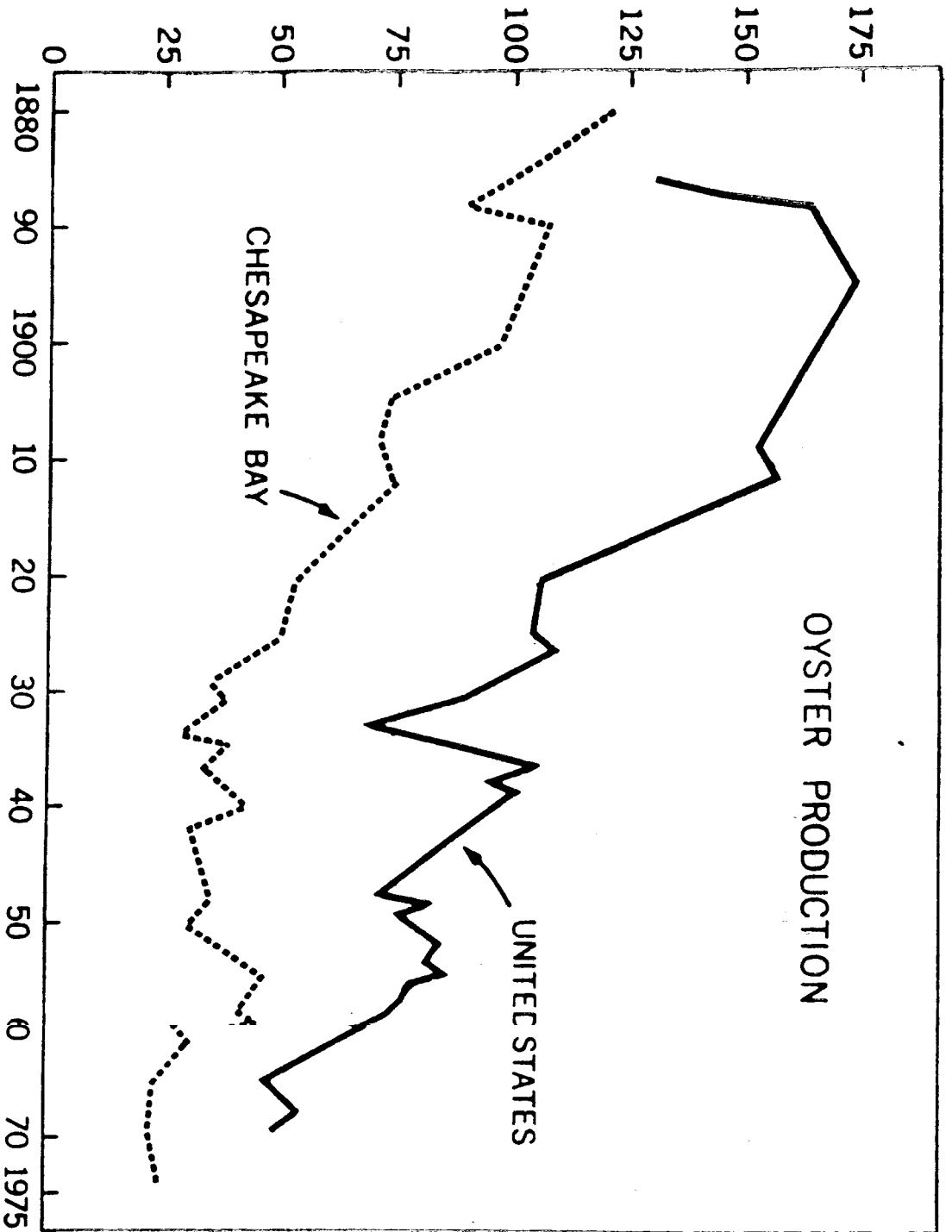

*Production of oysters (Crassostrea virginica) in Chesapeake Bay and in the United States, 1880 to 1975*

FROM: Merritt, Oyster Spat Set

MAP READING ACTIVITY

Directions for the teacher:

Prepare copies of the maps of the Chesapeake Bay, spring and autumn salinities, American Oyster in the Bay, and oyster predators in the Bay. You may want to make a set for every 2 students to share which would require a classroom set of only 12-16 depending on class size. Also prepare copies of the questions. (A Thermofax machine helpful here.)

Directions for the student:

Place a copy of the map of the Chesapeake Bay, spring and autumn salinities, American Oyster in the Chesapeake Bay, and oyster predators in the Chesapeake Bay (five in all) before you. Study the maps and prepare to answer the following questions.

NOTE:

The exercises vary in difficulty. Students will probably find exercise (a) fairly easy and exercises (b) and (d) difficult.



CHESAPEAKE BAY MAP

1. Is Baltimore north or south of the Potomac River? \_\_\_\_\_  
Is it on the eastern or western shore of the Bay? \_\_\_\_\_  
What really large river is it south of? \_\_\_\_\_  
This river is found in what two states shown on the map? \_\_\_\_\_  
\_\_\_\_\_
2. Is the Chesapeake Bay bridge north or south of Washington? \_\_\_\_\_
3. Which river is larger, the Potomac or the Patuxent? \_\_\_\_\_  
Which city would make a better port city, Baltimore or Washington?  
\_\_\_\_\_ Why? \_\_\_\_\_
4. In which direction would the net flow of water be, even with the back  
and forth action of the tides, towards Baltimore or towards Norfolk?  
\_\_\_\_\_
5. In which state does the larger portion of the Bay (in terms of length)  
appear to lie? \_\_\_\_\_ The James  
River was the site of the Kepone pollution that occurred recently.  
Kepone is a very poisonous chemical that was dumped into the river by  
a manufacturer. Where would you feel safer fishing for bluefish,  
Norfolk or Washington? \_\_\_\_\_ Why? \_\_\_\_\_  
\_\_\_\_\_

\*\*\*\*\*BONUS QUESTION\*\*\*\*\*

Where are the headwaters of the Bay? \_\_\_\_\_  
Where is the mouth? \_\_\_\_\_

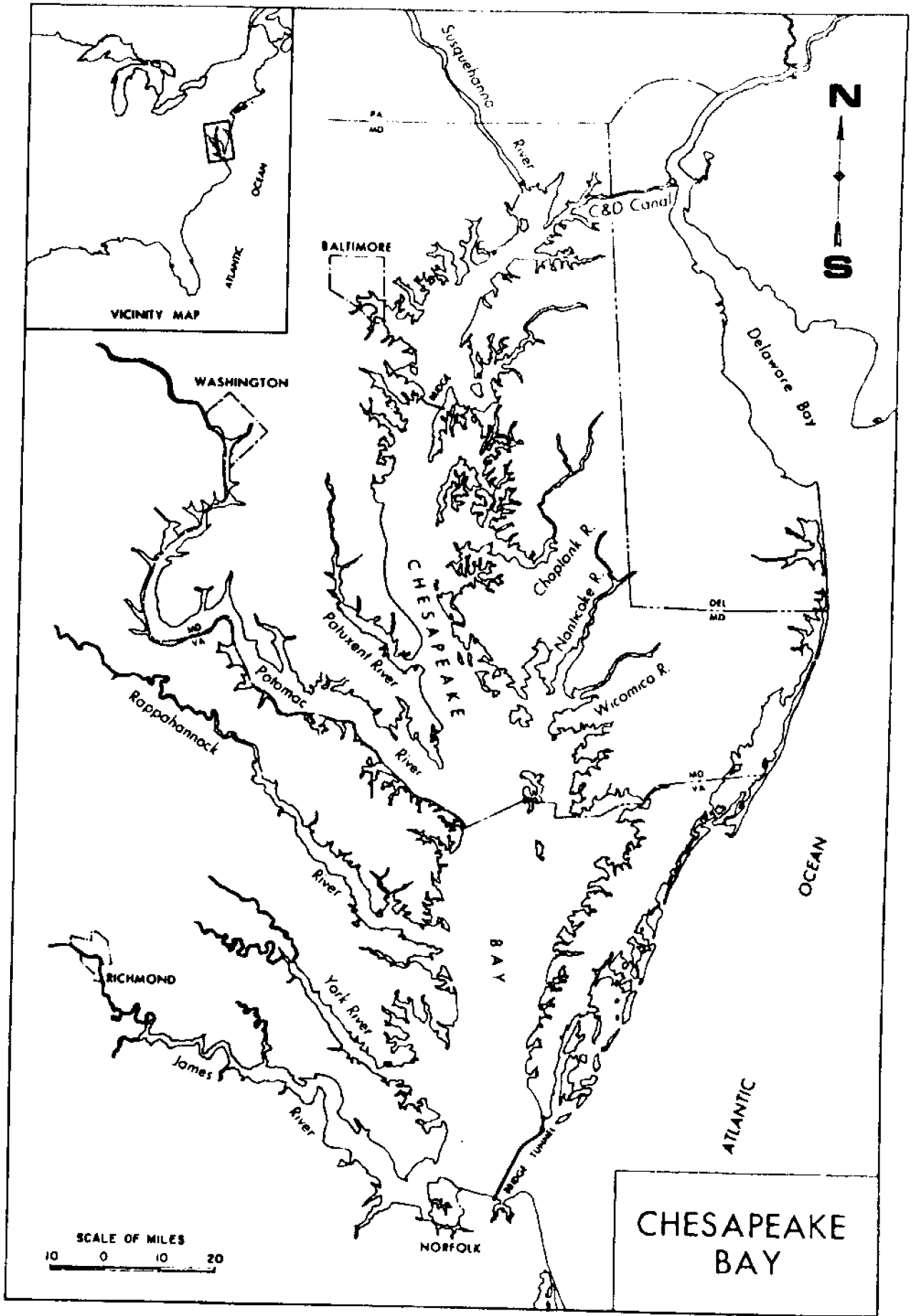

AMERICAN OYSTER AND OYSTER PREDATORS IN THE CHESAPEAKE BAY MAPS

1. How far north (near what large city) are oysters found in the Chesapeake Bay? \_\_\_\_\_ Would you expect as many there as at the Choptank River? \_\_\_\_\_ Referring to your previous maps can you explain why? \_\_\_\_\_
  
2. Below the Nanticoke and Wicomico Rivers oysters should be very plentiful and yet the beds are not as large as directly across the Bay on the western shore. Can you find any explanation for this, using the two maps? \_\_\_\_\_
  
3. Which predator has the wider range, Grosalpinx or Eupleura? \_\_\_\_\_ Can you give one possible reason why, referring to your other maps? \_\_\_\_\_

\*\*\*\*\*BONUS QUESTION\*\*\*\*\*

Off the coast of Maryland, where an island separates a small body of water from the Atlantic Ocean, there is a place that seems good for oysters. First, why would it be good? \_\_\_\_\_

Second, why is it difficult for oysters to reach maturity there? \_\_\_\_\_

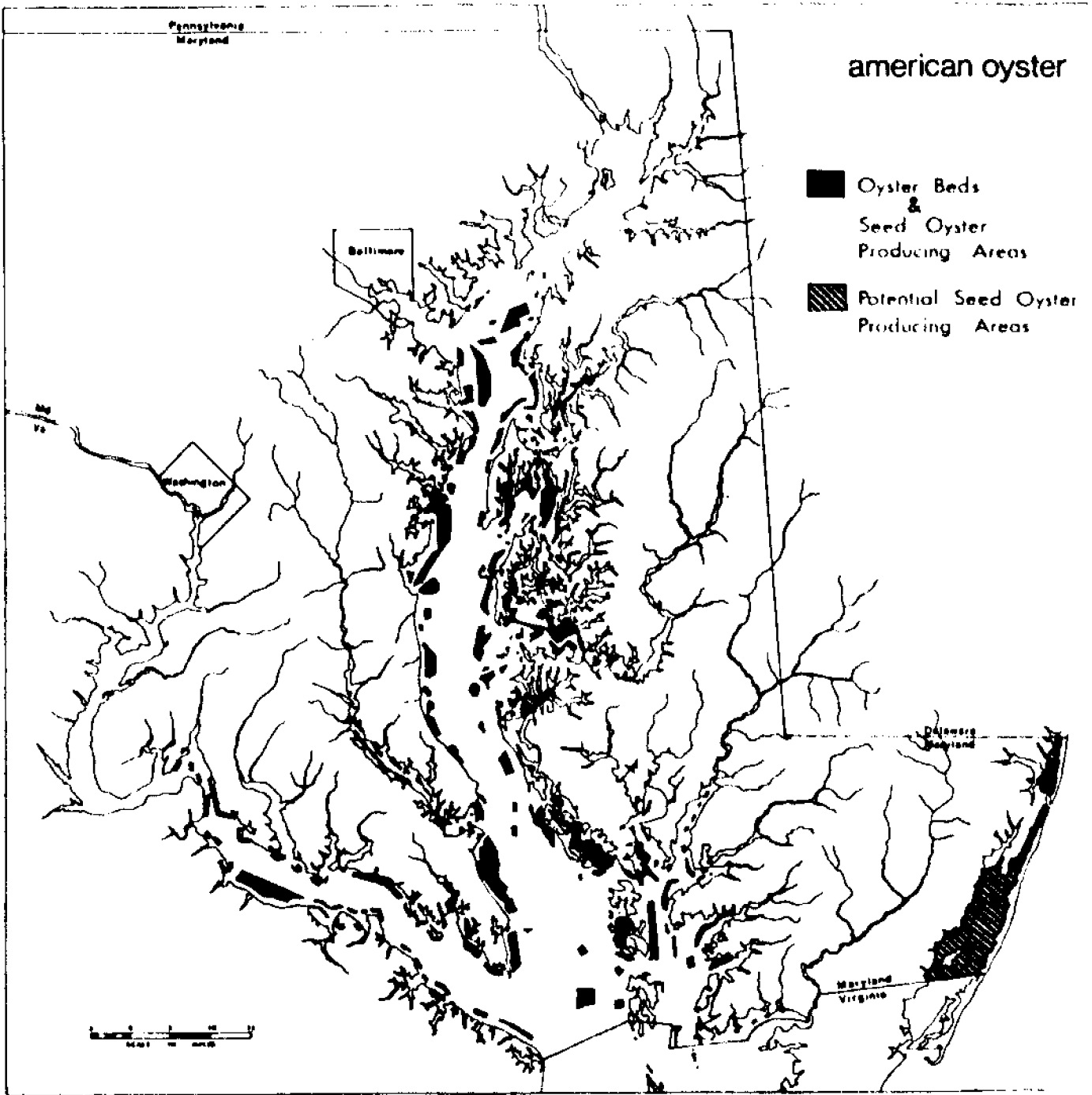

Drawing by Alice Jane Lippson, The Chesapeake Bay in Maryland

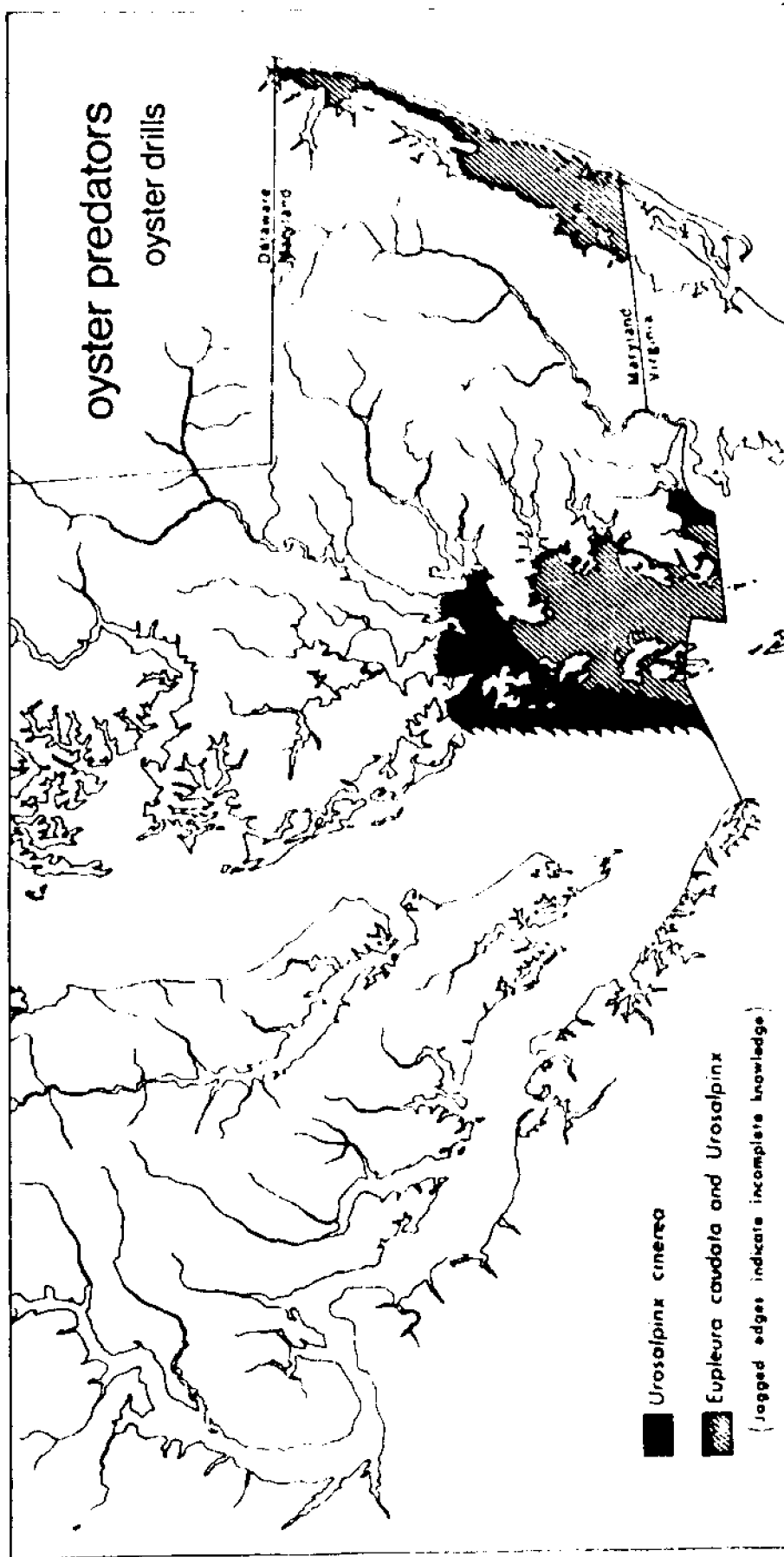

Drawing by Alice Jane Lippson,  
The Chesapeake Bay in Maryland

SPRING AND AUTUMN SALINITIES MAPS

1. What does salinity mean? \_\_\_\_\_ When we say the salinity of the lower Bay is 21 ppt what do we mean? \_\_\_\_\_  
\_\_\_\_\_
2. When is the salinity of the Bay at Baltimore greater, spring or autumn? \_\_\_\_\_ Can you explain why? \_\_\_\_\_  
\_\_\_\_\_
3. What is the highest salinity shown for the mouth of the Potomac? \_\_\_\_\_ Is this in the spring or autumn? \_\_\_\_\_  
\_\_\_\_\_
4. What is the highest salinity shown for the Bay? \_\_\_\_\_ At what season is this? \_\_\_\_\_ And where? \_\_\_\_\_  
\_\_\_\_\_
5. Oysters may be found in waters with a salinity of 8-9 ppt on up to full ocean salinity, over 30 ppt. Using your Chesapeake Bay map along with the salinity map, name six rivers that could have oysters in them. \_\_\_\_\_  
\_\_\_\_\_

\*\*\*\*\*BONUS QUESTION\*\*\*\*\*

Salt water is heavier than an equal volume of fresh water, due to the presence of the dissolved salt. Is the water heavier at the mouth of the Rappahannock River or at the eastern shore directly across from it?

Centrifugal force is the force throwing heavier objects farther away from the center of the spinning body. Looking at the salinity lines would you say the Earth is spinning from east to west or west to east? Why? \_\_\_\_\_  
\_\_\_\_\_

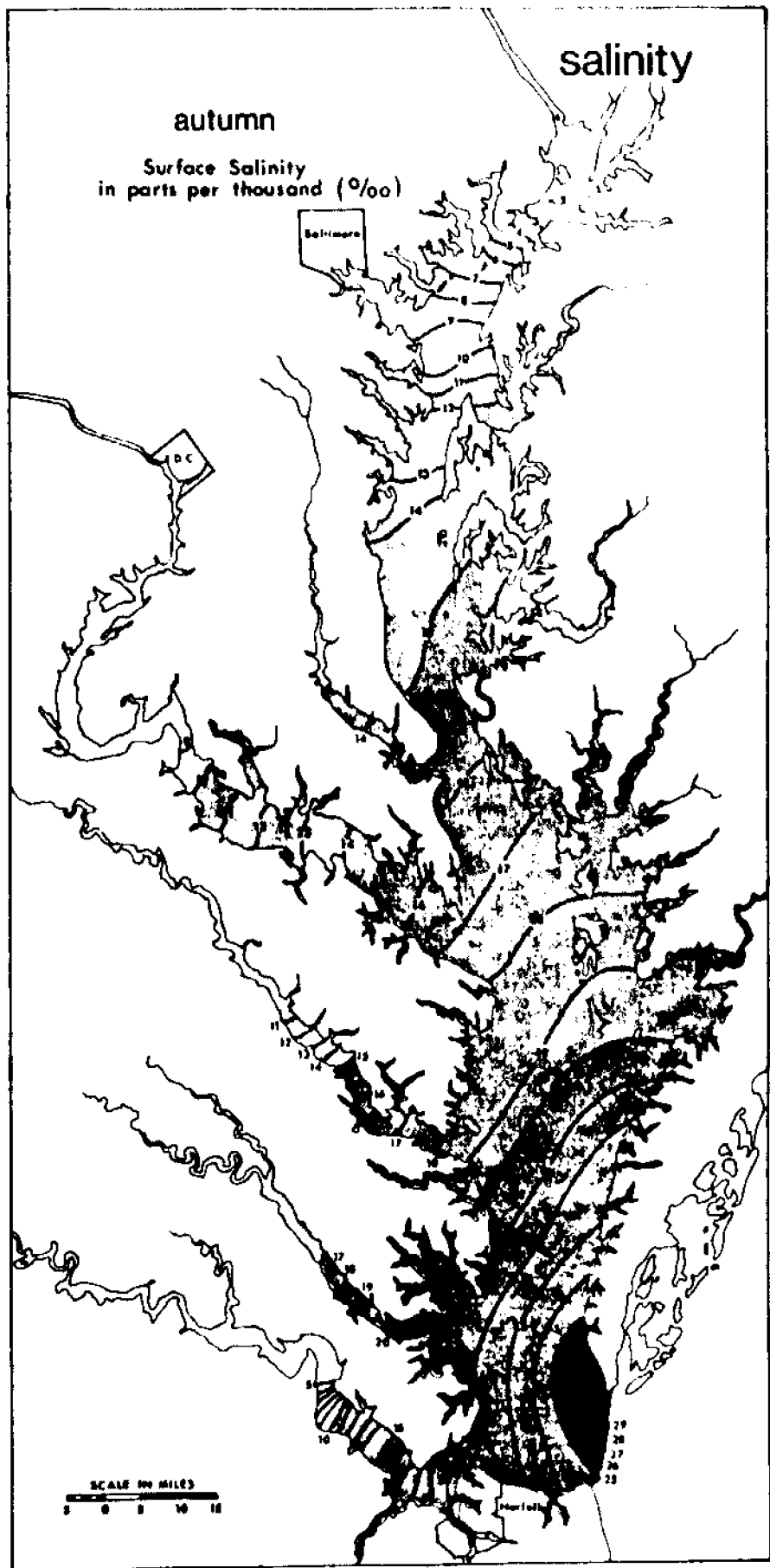

Drawing by  
Alice  
Jane  
Lippson,  
The  
Chesapeake  
Bay  
in  
Maryland

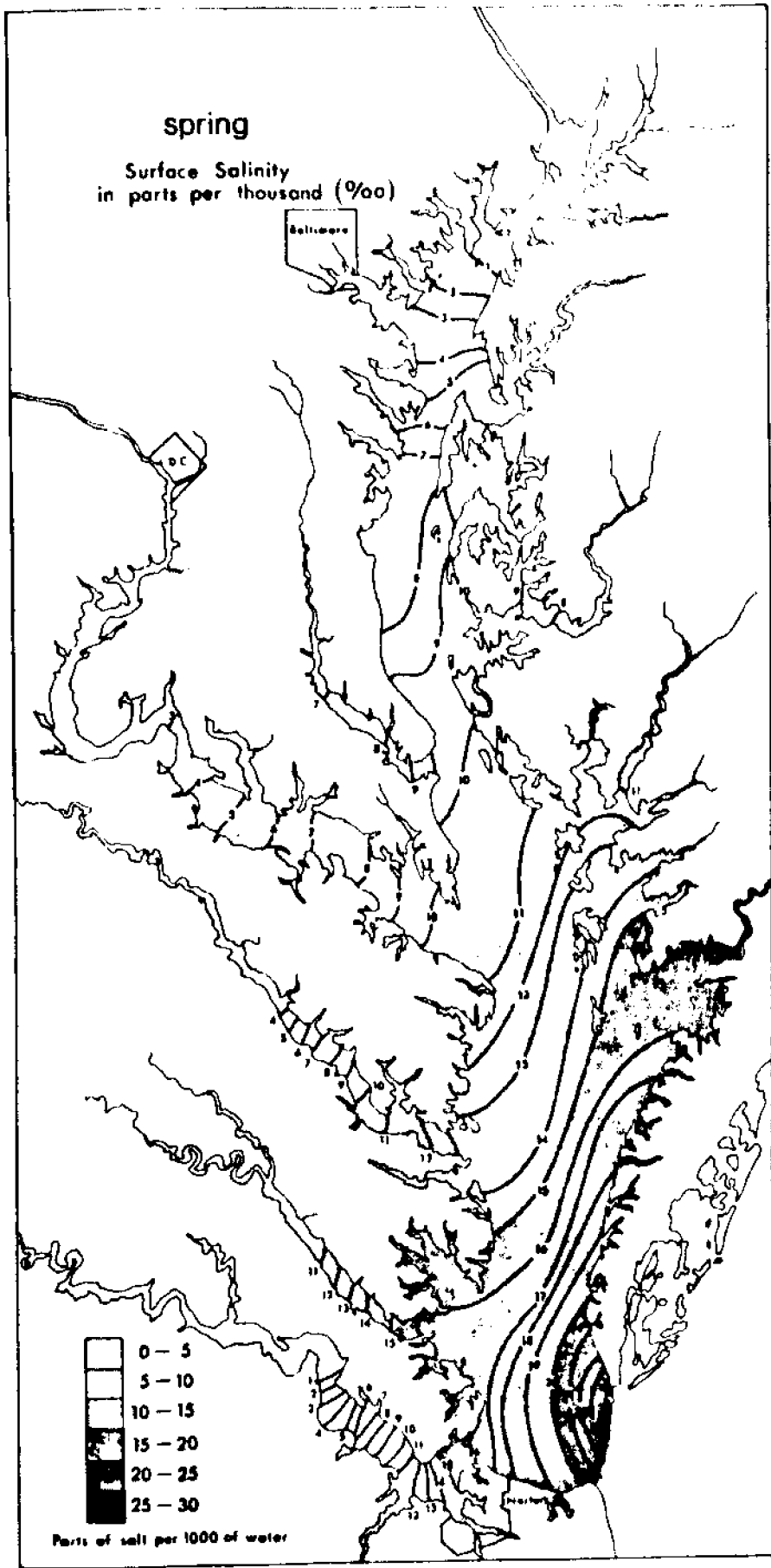

Drawing by  
Alice  
Jane  
Lippson,  
The  
Chesapeake  
Bay  
in  
Maryland



ANSWER SHEET

Graph Interpretation (Activity 1)

Production of oysters in Chesapeake Bay and in the U.S. 1880-1975.

Activity:

Look at the graph on oyster production and answer the following questions.

1. What is the largest amount in millions of pounds of oyster meat that was harvested in a single year? Write this amount in a numerical figure. 175,000,000  
Is this answer for the U.S. or for the Chesapeake Bay? U.S.
2. Using a straight edge held even or parallel to the bottom or horizontal axis of the graph, what is the smallest amount in millions of pounds harvested in one year? About 20 - 22 million  
Was this in the Bay or the U.S.? In the Bay  
What year did this occur? About 1970
3. Would you say oyster production is on the increase (going up) or on the decrease (going down) since 1880? Decrease
4. Using a straight edge held even or parallel to the side or vertical axis of the graph, at about what year in the twentieth century did oyster production in the U.S. show a dramatic or sharp increase? (the largest single increase on the graph) 1932 - 1938
5. What was the amount in millions of pounds of oyster meat produced in the Chesapeake Bay in 1975? About 23 - 24 million  
Does this appear to be more or less than in 1970? More

\*\*\*\*\*BONUS QUESTION\*\*\*\*\*

If we read the 1970 oyster production figure for the U.S. as 50 million pounds, how many tons was that? (A ton is 2,000 pounds.)  
25,000 Tons

Show your work.

$$50,000,000 \div 2,000 = 25,000$$

OR

$$50,000,000 \div 2,000 = 25,000$$

ANSWER SHEET

Chesapeake Bay Map (Activity 2a)

1. Is Baltimore north or south of the Potomac River? north  
Is it on the eastern or western shore of the Bay? western  
What really large river is it south of? Susquehanna  
This river is found in what two states shown on the map?  
Pennsylvania and Maryland (Note: A larger map would show the source,  
further north.)
2. Is the Chesapeake Bay bridge north or south of Washington? north
3. Which river is larger, the Potomac or the Patuxent? Potomac  
Which city would make a better port city, Baltimore or Washington?  
Baltimore Why? Directly on the Bay
4. In which direction would the net flow of water be, even with the back  
and forth action of the tides, towards Baltimore or towards Norfolk?  
Towards Norfolk
5. In which state does the larger portion of the Bay (in terms of length)  
appear to lie? Maryland The James  
River was the site of the Kepone pollution that occurred recently.  
Kepone is a very poisonous chemical that was dumped into the river by  
a manufacturer. Where would you feel safer fishing for bluefish,  
Norfolk or Washington? Washington Why? Further from  
the James and source

\*\*\*\*\*BONUS QUESTION\*\*\*\*\*

Where are the headwaters of the Bay? Susquehanna (north of Baltimore)  
Where is the mouth? at the Atlantic Ocean (near Norfolk)

ANSWER SHEET

AMERICAN OYSTER AND OYSTER PREDATORS IN THE CHESAPEAKE BAY MAPS (ACTIVITY 2b)

1. How far north (near what large city) are oysters found in the Chesapeake Bay? Baltimore Would you expect as many there as at the Choptank River? No  
Referring to your previous maps can you explain why? Greater salinity at Choptank favors spawning and faster growth
2. Below the Nanticoke and Wicomico Rivers oysters should be very plentiful and yet the beds are not as large as directly across the Bay on the western shore. Can you find any explanation for this, using the two maps? Predators on eastern shore
3. Which predator has the wider range, Urosalpinx or Eupleura? Urosalpinx  
Can you give one possible reason why, referring to your other maps? Can tolerate lower salinities

\*\*\*\*\*BONUS QUESTION\*\*\*\*\*

Off the coast of Maryland, where an island separates a small body of water from the Atlantic Ocean, there is a place that seems good for oysters. First, why would it be good? Because of high salinity (also: protected waters and proper depths).  
Second, why is it difficult for oysters to reach maturity there? Because of predators

ANSWER SHEET

Salinities Maps (Activity 2c)

1. What does salinity mean? Amount of salt in the water. When we say the salinity of the lower Bay is 21 ppt what do we mean? There are 21 parts of salt to every thousand parts of water
2. When is the salinity of the Bay at Baltimore greater, spring or autumn? Autumn Can you explain why? Spring rains and runoff bring freshwater into the Bay
3. What is the highest salinity shown for the mouth of the Potomac? Between 16 - 18 ppt Is this in the spring or autumn? Autumn
4. What is the highest salinity shown for the Bay? 29 ppt  
At what season is this? Autumn And where? Mouth
5. Oysters may be found in waters with a salinity of 8-9 ppt on up to full ocean salinity, over 30 ppt. Using your Chesapeake Bay map along with the salinity map, name six rivers that could have oysters in them. James, York, Rappahannock, Potomac, Patuxent, Choptank

\*\*\*\*\*BONUS QUESTION\*\*\*\*\*

Salt water is heavier than an equal volume of fresh water, due to the presence of the dissolved salt. Is the water heavier at the mouth of the Rappahannock River or at the eastern shore directly across from it?

eastern shore

Centrifugal force is the force throwing heavier objects farther away from the center of the spinning body. Looking at the salinity lines would you say the Earth is spinning from East to West or West to East?

From West to East

Why? Because heavier salt

water is thrown toward the east:

## WHAT'S IN A NAME?

### Teaching Scientific Classification

#### Background:

The scientific name for the American or Chesapeake Bay oyster is *Crassostrea virginica*. Many students may question the necessity for this long Latin term. Point out to them that a plant or animal may have more than one common name, especially in different sections of the country. For example, a skunk may be a pole cat; the striped bass is known as a rockfish in Maryland; a cougar may be called a mountain lion, a puma, or a wildcat. In the plant kingdom names become even more confusing. The box elder tree, for example, is also known as an ash-leaved maple. It should be evident that a system for giving a plant or animal a specific name, in a language accepted all over the world, is very necessary to avoid confusion.

Linnaeus, the Swedish botanist who is known as the father of taxonomy (the science of classification), came up with the binomial system of nomenclature. He chose Latin, which is neutral since it's no longer spoken. "Binomial" means two names: a generic or genus name, and a specific or species name. The genus is a group of very similar beings; for example, oysters are known as *Crassostrea* and maples are known as *Acer*. Since there can be many different kinds of oysters or maple trees, a specific name is needed to classify them further. A Chesapeake Bay oyster is *Crassostrea virginica*, whereas a West Coast oyster is *Crassostrea gigas* (which is larger as its name suggests). A silver maple is *Acer saccharinum*, whereas a sugar maple is *Acer saccharum*. Scientific names, since they are in Latin, are always underlined or italicized.

In order to identify a plant or animal, a dichotomous key is used, dichotomous meaning "divided into two parts." When going through a key, a person always has two choices; for instance in a plant key, there might be a choice between "with thorns" and "without thorns." In order to illustrate how a dichotomous key might be made, do the following activity with the class.

#### Activity:

Have ten or more students take off their right shoe and place it on a lab table at the front of the room. Tell them they are to use their own descriptions to classify the various shoes, making their own key which will be recorded on the board. Since a key always starts with the larger or more important differences and works down to the narrower or finer differences, there should be a lot of discussion when deciding

which differences should come first: e.g., leather/not leather, laces/  
no laces, or heel/no heel.

As an example of scientific labeling, the following classification  
of the oyster could be put on the board, with the explanation that the  
differences become finer as one moves from kingdom to species:

Kingdom	Animal
Phylum	Mollusca
Class	Pelecypoda
Order	Filibranchia
Family	Ostreidae
Genus	Crassostrea
Species	virginica

## Let's Make Oyster Stew

In this laboratory activity a number of skills come into play: measurement, marketing, group interaction, and following directions. The activity could be handled in a number of ways. It could be made interdisciplinary by including the home economics department, using, perhaps, their lab. Or, it could be done in a regular classroom by borrowing hot plates, electric skillets, or deep-fat fryers. Explain to the class that oysters may be harvested only in months containing an R in the name: September through April. Originally this ruling was made because oysters taken during the summer were thought to be unwholesome. This was probably due to the lack of adequate refrigeration and not to any condition of the oyster itself. It is now known that an oyster is as wholesome and tasty in the summer as in the winter, though the "R" rule has been continued for the sake of conservation. May through August now represents a resting period for the oyster, which spawns during this time, and this helps assure reproduction and the continuation of the oyster crop.

Oysters are graded for the market into five classes based on size:

Small--over 35 oysters per pint (not legal in Maryland)  
Standards--small, 25-35 oysters per pint  
Selects--16-25 oysters per pint  
Extra Select--16-20 oysters per pint  
Counts--large, fewer than 16 oysters per pint

The last two classes are usually found in restaurants only. The price of these four classes increases from standards to counts, which are the most expensive. The classification is according to size only and has nothing to do with taste or quality, so the best value for oyster stew would be standards.

### Activity:

This lab activity will be done best by small groups or teams, so divide the class into groups of six to eight students. Present them with the recipe and the problem of procurement. Are they going to divide up the ingredients and each bring something? Or are they going to appoint a shopper to determine prices and cost, dividing it equally and collecting from everyone, and then do the actual shopping? Remind them that they may want to add oyster crackers, napkins, disposable bowls and spoons to their lists. In their discussion they should also decide what day they want to do it, if this hasn't been decided for them, and whether or not they would like to invite a guest, perhaps the principal, a counselor, or a teacher. This is a good culminating,

reward-oriented activity. A Friday would be a good day for this, and if time allows it could be followed by a game or two of Oyster Rummy or Benthic Bingo.

Note:

Any number of departures could be made from this activity. If you are fortunate enough to live in Bay country, there may be a parent who could bring the oysters in the shell and could show the students how to shuck them. In the shell, especially, it would be easy to go over oyster anatomy, locating the parts.

#### Oyster Stew

1 pt. shucked standard oysters with liquor (liquid from inside oyster)	salt and pepper to taste seafood seasoning, if desired
1 qt. hot milk	
1/4 cup margarine or butter	

Cook oysters in their liquor until edges curl, about 5 minutes. Add milk, margarine or butter, salt and pepper. Heat, but do not boil. Serve at once. For an extra "zip," sprinkle seafood seasoning on each serving.

Makes 6 servings, about 1 cup each.

#### Shopping List:

1 pt. oysters  
1 qt. milk  
1/4 cup margarine, or butter (1/2 stick)  
oyster crackers, if desired

#### Things needed:

salt and pepper  
hot plate or electric skillet or cooker of some sort  
large spoon or soup ladle  
seafood seasoning, if desired  
bowls and spoons--purchased or brought from home  
napkins



## NAME THAT PART

### Note to the teacher:

It is much easier to open an oyster for anatomical study by first narcotizing it. Not only does a narcotized oyster no longer require force to be opened, but its organs and tissues remain fully expanded in their normal position and are undistorted by contraction. One of the best methods of narcotizing is to use technical magnesium sulfate (Epsom salts).

### The Procedure:

Thoroughly scrub the oyster and place it in a container about 8 to 9 inches in diameter and 3 inches deep, filled with sea water. During the first 24 hours add small quantities of Epsom salts gradually until a 5 to 10 percent concentration is reached. (If the Epsom salts are added too rapidly, the oyster will close its valves, and prolong the process.) Then the oyster should be left undisturbed for 24 to 48 hours at room temperature. Additional amounts of salt may be added because oysters can tolerate much higher concentrations, recovering when placed in running sea water. The oyster is completely narcotized when it doesn't respond to touch, or prick at the edge of the mantle. The oyster may be opened by placing a knife between the mantle and the right valve, and pushing it carefully above the meat to the adductor muscle, keeping the blade at a sharp angle to the inner surface of the valve. This is best done by rocking the oyster back and forth while pressing it with a knife. After the adductor muscle is severed, lift the right valve until the ligament breaks. Then the oyster is exposed in the cupped valve which retains sea water. If extensive further preparation of the organ systems is desired by injection of various dyes, see Galtsoff, The American Oyster, P. 66.

NAME THAT PART!

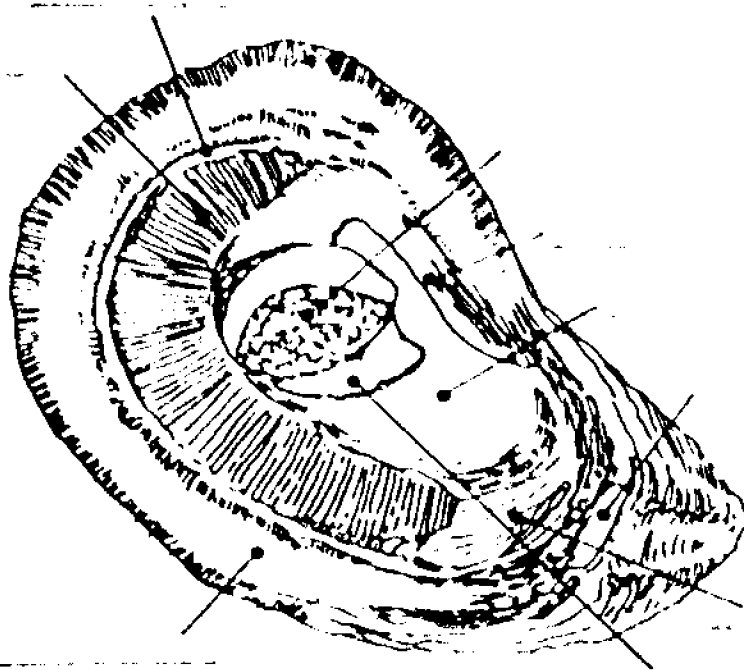

From The Maryland Oyster, Fred W. Stieling

Activity:

Place a freshly shucked oyster (right valve removed) in front of you. Orient your oyster so that the narrow part of the shell is pointing downward and to the right, as in the diagram. See if by memory you can locate the parts indicated by the arrows in the diagram, in your freshly opened oyster. Label the parts in your diagram above.

Answer the following questions:

1. From the color of the mantle, what condition would you say your oyster is in? Lean oysters with no stored food, or glycogen, are gray; "fat" oysters with stored glycogen are white; and oysters about to spawn or release sex cells are creamy yellowish.
2. If you have determined your oyster is ready to spawn, can you locate the gonads (visible only at spawning time), located near the hinged area overlying the stomach? If you can, sketch them in on your diagram.

- . In looking at your oyster can you understand why it is a sessile animal--an animal that spends its adult life attached to some surface? \_\_\_\_\_ What would he need that he does not have in order to lead a more "active" life? \_\_\_\_\_
- . Although the rectum or anus is not indicated on the diagram, where would you suspect it might be? The rectum and anus are organs through which waste products from digestion are eliminated. Indicate where you think it might be on your diagram and label it.  
\_\_\_\_\_
- . Using a hand lens look at the edge of the mantle closely to see if you can see any of the small tentacles the oyster uses for sensing its environment. Do you see any? \_\_\_\_\_
- . Do you see any eyes, ears, or nose on the oyster? \_\_\_\_\_  
Do you think it is necessary for the oyster's success in his environment to have the same senses we do? Why or why not?  
\_\_\_\_\_
- . Do you see any water or liquid around the edge of the mantle at the edge of the shell? \_\_\_\_\_ This water is called shell liquor. Have you any idea how the oyster is able to survive several days in a basket or container in a cool place without being in water? Explain \_\_\_\_\_

Food for thought--additional research activities for extra credit:

1. The oyster has survived for millions of years in the form you see before you. If he is to continue to survive in a world affected more and more by man and his activities, what changes in structure might help him?
2. The oyster shell is made of calcium carbonate, the material found in chalk, eggshell, and lime to name a few substances. Oyster shell is considered an important byproduct. As a home research or library project, look up possible uses for the oyster shell.

NAME THAT PART!

Answer Sheet

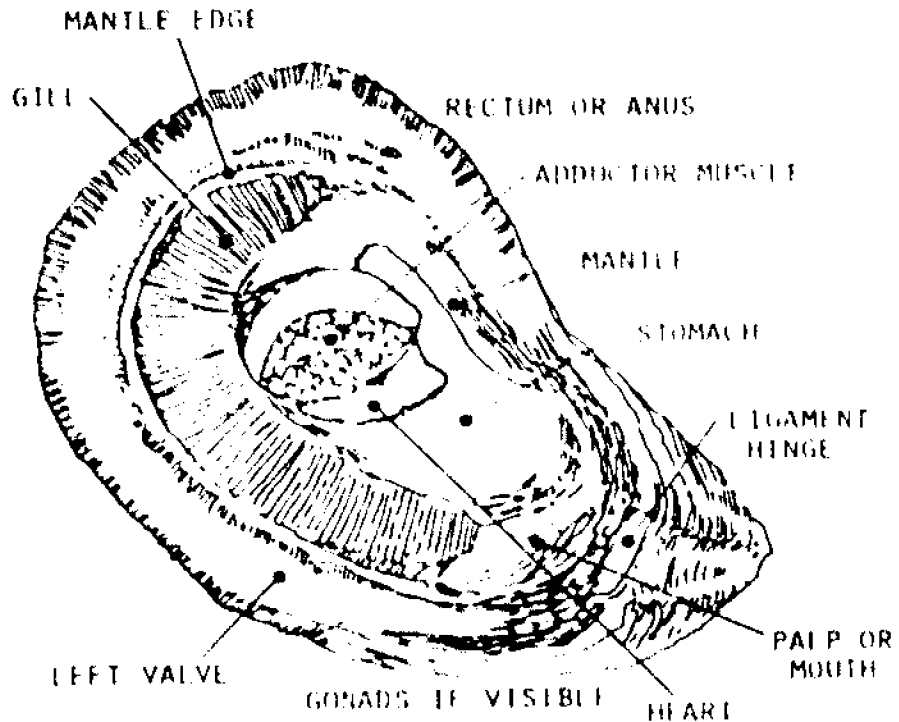

From The Maryland Oyster,  
Fred W. Stelling

Activity:

Place a freshly shucked oyster (shucked by having right valve removed) in front of you. Orient your oyster so that the narrow part of the shell is pointing downward and to the right, as in the diagram. See if by memory you can locate the parts indicated by the arrows in the diagram in your freshly opened oyster. Label the parts in the diagram above.

Answer the following questions:

1. From the color of the mantle, what condition would you say your oyster is in? Lean oysters with no stored food, or glycogen, are gray; "fat" oysters with stored glycogen are white; and oysters about to spawn or release sex cells are creamy yellowish.  
(one of three above)
2. If you have determined your oyster is ready to spawn, can you locate the gonads, visible only at spawning time and located near

the hinged area overlying the stomach? (yes or no) If you can, sketch them in on your diagram.

3. In looking at your oyster can you understand why it is a sessile animal--an animal that spends its adult life attached to some surface? (yes or no) What would he need that he does not have in order to lead a more "active" life? a foot or some means of locomotion
4. Although the rectum or anus is not indicated on the diagram, where would you suspect it might be? The rectum and anus are organs through which waste products from digestion are eliminated. Indicate where you think it might be on your diagram and label it. (shown on answer diagram)
5. Using a hand lens, look at the edge of the mantle closely to see if you can see any of the small tentacles the oyster uses for sensing its environment. Did you see any? (yes or no)
6. Do you see any eyes, ears, or nose on the oyster? no Do you think it is necessary for the oyster's success in his environment to have the same senses we do? Why or why not? no, he remains in one place his whole adult life and filters his food from moving water.
7. Do you see any water or liquid around the edge of the mantle at the edge of the shell? Yes This water is called shell liquor. Have you any idea how the oyster is able to survive several days in a basket or container in a cool place without being in water? Explain: he closes his shell tightly and with the water trapped inside it he can get oxygen.

Food for thought--additional research activities for extra credit:

1. The oyster has survived for millions of years in the form you see before you. If he is to continue to survive in a world affected more and more by man and his activities, what changes in structure might help him? A foot and better sense organs to allow mobility (other answers possible)
2. The oyster shell is made of calcium carbonate, the material found in chalk, eggshell, and lime to name a few substances. Oyster shell is considered an important byproduct. As a home research or library project, look up possible uses for the oyster shell. to supplement chicken feed, to make lime for agriculture, to spread on oyster bars as culch, to fill holes in dirt roads, to line gardens, to skim on the water for fun, etc.

## OYSTER RUMMY

### Activity:

This game involves four players, a deck of cards, and a listing in proper order of the life cycle of the oyster on the board. The players are dealt six cards with the remaining cards face down in the middle with one turned face up beside it. Each player then has an option at a turn: Either a card from the remaining deck, or the top card in the discard pile. Then the player must discard a card. Once the remaining deck has been gone through, then the discards may be turned over to continue the game. The object is to get a Rummy consisting of five cards, in order, from the life cycle written on the board. The first person to do this is a winner. By making several decks, the whole class may be involved.

### Life Cycle of Oyster:

sperm  
egg  
fertilized egg  
larval stage  
veliger  
umbo stage  
cultch  
spat  
young oyster  
gonadal development  
mature oyster  
above 20° C.  
spawning stage

### Instructions for preparation of a sheet suitable for ditto to prepare the Oyster Rummy card deck:

Have the sheet (or sheets) divided into 13 rectangles, playing card size, and on each card place the word or phrase from the life cycle listing. A drawing of the item named should be included, if possible. Duplicate, cut the duplicated sheets, and glue each piece to cardboard of the same size. Laminate for durability, if possible.

OYSTER FUN

E S T U A R Y A O U Y T I V I H M O G O B S L O A U O K E I  
 O Y S T E R F U N A B C D E R M O D F F G H H I J K L M E N  
 S I L T O P Q A Q U A C U L T U R E R E R S T U V E W X Y F Z A  
 F U N G U S B C D E S F G L H I J K L M M S X N L O F P P Q  
 R S B I V A L V E T Z U V E W S I L T A T I O N X L Y Z A A  
 B C D T I F G H I S L J K G L M N N O P Q R S T U V F W R X  
 Y Z A M I D D E N S I B C E D E E F G H I J K E L M N I A O  
 P R O T A D E R P Q N L R R S M T F U B F U N G U S W X S Y  
 P Z A B C C A D M E I F T G T H I J I K L T M N O T P Q I R  
 A L R S T O U L E V T W X I D E E S Y L Z A S P A T S E T B  
 T C A D E M F G T H Y I U J K L M K M N T O P P Q R S T E U  
 E Y W N X P Y Z A A B R K C A J P I K S C E S P A T F A L L  
 N D E F K E G H M N C U L T C H I P D J R K R I L M W N O P Q  
 T R M S T T U V O E W X Y Z A B C J D D E U F F G H N I T J  
 T K A L M I O N R G L Y C O G E N A O P E Q C R E S T I O U  
 O V R W X T Y N P O Z C Y A B N C C D E F N G K H E I J N K  
 N L I M O O Q H H C I I T T E E K K G C V W S E E D D X G G  
 G Y C Z A R B C O Y D H I E F G G H R O I J K L M R N E O P  
 S H U C K Q R S S L T T N U V Y W P E L A G I C X Y Z A R B  
 C D L E F G H I E G J N I K Y X L M G I V E L I C E R R N P  
 G O T R I B U T A R Y E L R P O Q R A F S T U V W M S X Y E  
 N Z U Y A B C D E F G B A H I D J K R O C L M G O N A D A L  
 O N R T O P Q E S P A T S E T E R S I R T U V L V W X Y N A  
 T Z E I A B C C D E U M B O F V G H O M I J L K L M N O O G  
 T P Q D R S T D U B V W X Y O L Z A U B C U D T A P S E T I  
 N F G I H I J E I K L M N O M O P Q S R S S T U C V W X K C  
 E Y Z B A P A R A S I T E B R S H U C K E R C D E H F C N H  
 T I J R K L T D M N O P Q R E S S T U V C I N E G O H T A P  
 A W X U Y H E R M A P H R O D I T E Z A B C D E F G H I L J  
 P R O T O Z O A N K U M B O L D M N O P E V L A V I B Q P R

Aquaculture	Dredge	Hermaphrodite	Patent tong (2)
Benthic	Effluent	Mariculture	Pathogenic
Bivalve (2)	Estuary	Metamorphose	Pelagic (2)
Coliform	Filter Feeder	Middens (2)	Plankton (2)
Competitor	Fungus (2)	Mollusk	Predator (2)
Cultch (2)	Glycogen (2)	MSK (2)	Protozoan
Dermo (2)	Gonadal	Oyster fun	Recruitment
Dissolved oxygen	Gregarious	Parasite (2)	Salinity (2)
Seed (2)	Siltation	Spawning	Veliger
Shellfish (2)	Skipjack	Subtidal	
Shuck	Spat (2)	Tong	Hint: Words are
Shucker (2)	Spatfall (2)	Turbidity	spelled upsidedown
Silt (2)	Spat set	Umbo (2)	and/or backwards in
			some places.

OYSTER FUN  
Answer Sheet

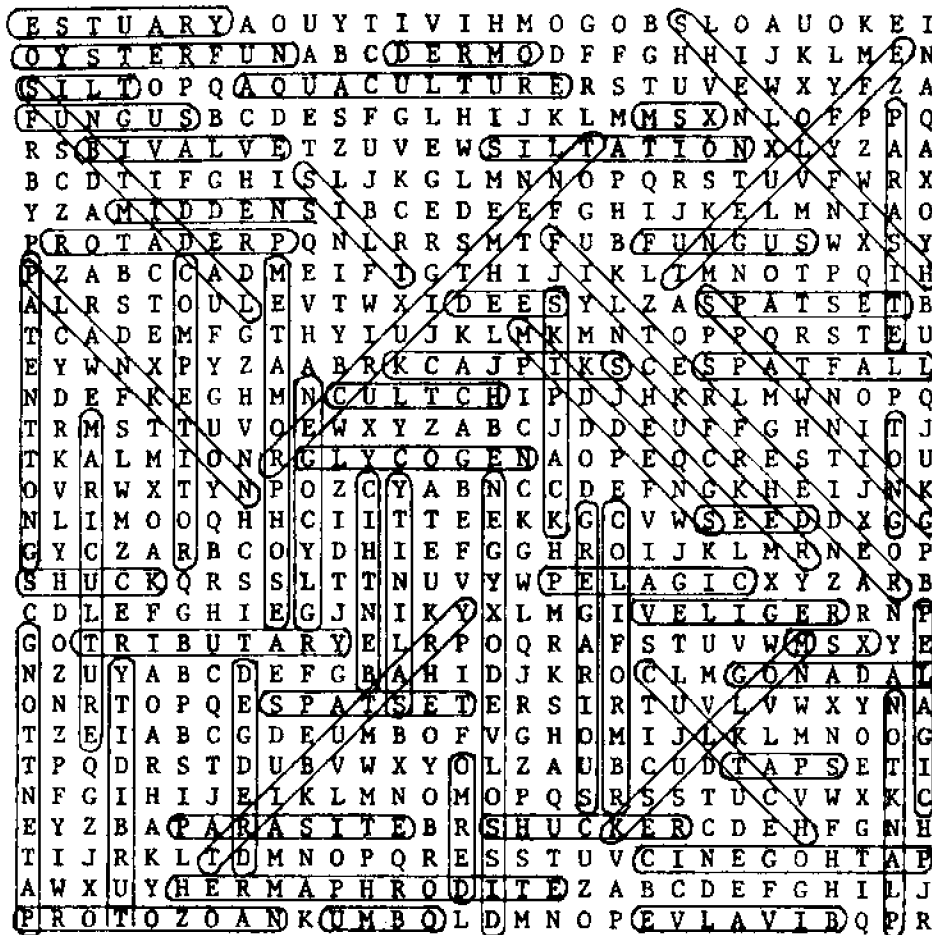

- |                  |               |               |                 |
|------------------|---------------|---------------|-----------------|
| Aquaculture      | Dredge        | Hermaphrodite | Patent tong (2) |
| Benthic          | Effluent      | Mariculture   | Pathogenic      |
| Bivalve (2)      | Estuary       | Metamorphose  | Pelagic (2)     |
| Coliform         | Filter Feeder | Middens (2)   | Plankton (2)    |
| Competitor       | Fungus (2)    | Mollusk       | Predator (2)    |
| Cultch (2)       | Glycogen (2)  | MSK (2)       | Protozoan       |
| Dermo (2)        | Gonadal       | Oyster fun    | Recruitment     |
| Dissolved oxygen | Gregarious    | Parasite (2)  | Salinity (2)    |
| Seed (2)         | Siltation     | Spawning      | Veliger         |
| Shellfish (2)    | Skipjack      | Subtidal      |                 |
| Shuck            | Spat (2)      | Tong          |                 |
| Shucker (2)      | Spatfall (2)  | Turbidity     |                 |
| Silt (2)         | Spat set      | Umbo (2)      |                 |



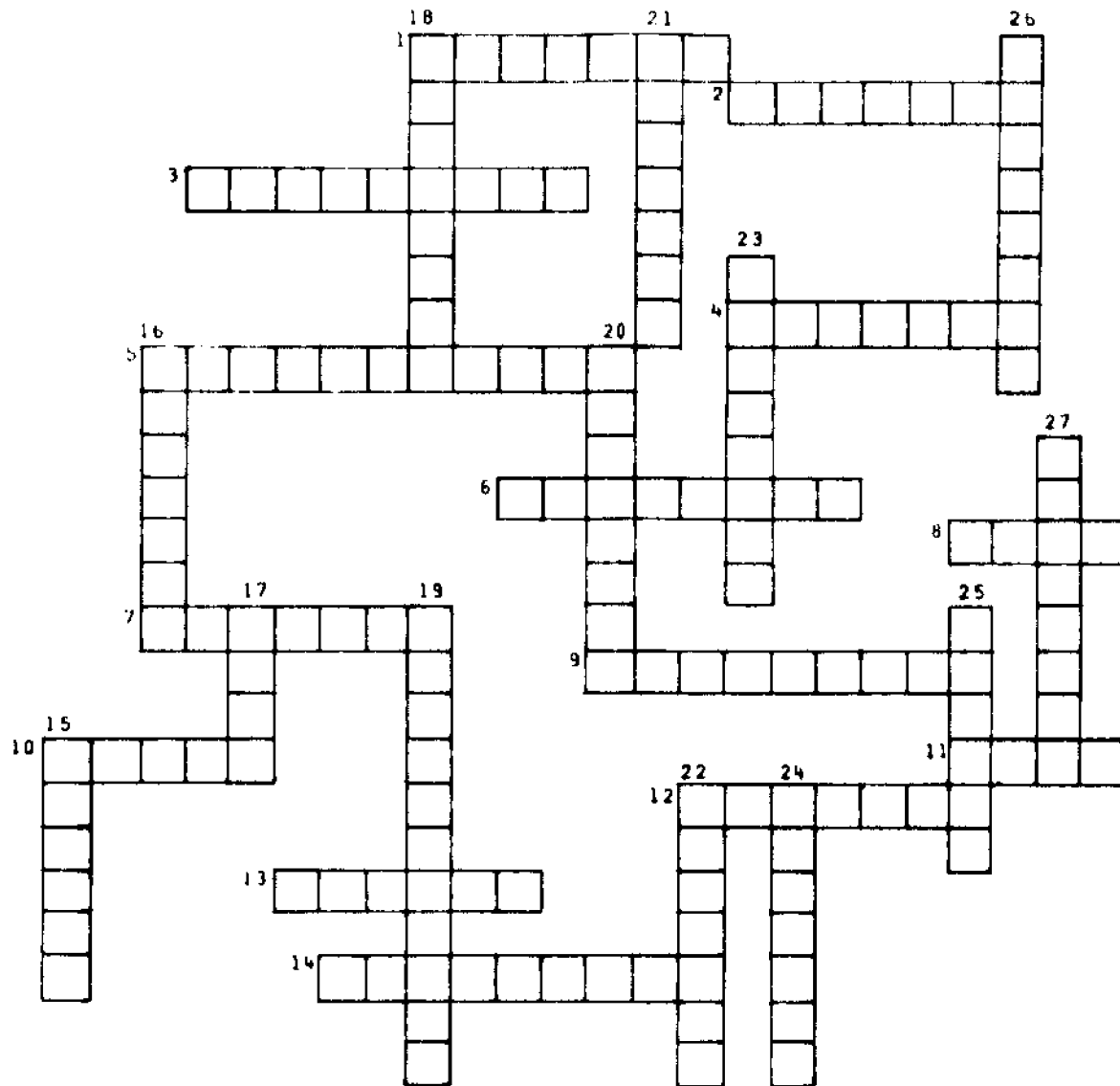

## Oyster Cross

### ACROSS

1. The act of attachment by the larval oyster.
2. Invertebrate animal in a shell.
3. A stream or river that feeds a larger body of water.
4. Oceanic.
5. Farming the sea.
6. The amount of salt in water
7. One who opens oysters.
8. A newly settled oyster.
9. Same as 3 Across.
10. A fungus that grows on oysters.
11. An instrument for gathering oysters.
12. A two shell mollusk.
13. Material used to collect oyster spat.
14. An aquatic invertebrate with a shell.

### DOWN

15. A device for gathering oysters
16. A refuse heap of old oyster shells.
17. The bumps of a bivalve shell.
18. Below the low tide line.
19. Spat set and growth to commercial size.
20. The runoff of liquid from a system.
21. A partially enclosed body of water.
22. Bottom dwelling.
23. The act of releasing eggs.
24. Oyster larvae.
25. The most important shellfish in the Bay.
26. A sailing vessel used to harvest oysters.
27. Microscopic life in the ocean.

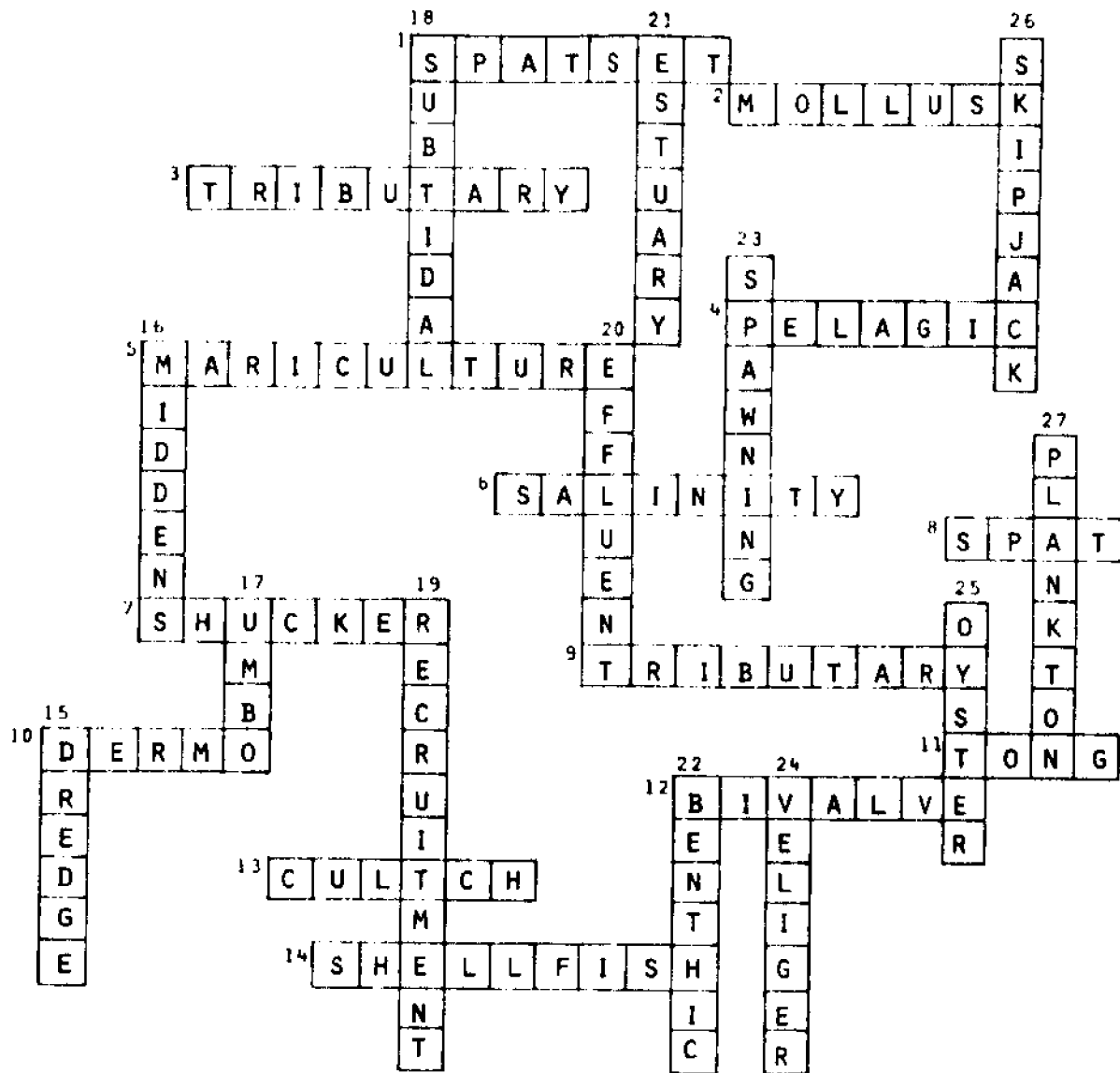

## Oyster Cross

### ACROSS

1. The act of attachment by the larval oyster.
2. Invertebrate animal in a shell.
3. A stream or river that feeds a larger body of water.
4. Oceanic.
5. Farming the sea.
6. The amount of salt in water
7. One who opens oysters.
8. A newly settled oyster.
9. Same as 3 Across.
10. A fungus that grows on oysters.
11. An instrument for gathering oysters.
12. A two shell mollusk.
13. Material used to collect oyster spat.
14. An aquatic invertebrate with a shell.

### DOWN

15. A device for gathering oysters
16. A refuse heap of old oyster shells.
17. The bumps of a bivalve shell.
18. Below the low tide line.
19. Spat set and growth to commercial size.
20. The runoff of liquid from a system.
21. A partially enclosed body of water.
22. Bottom dwelling.
23. The act of releasing eggs.
24. Oyster larvae.
25. The most important shellfish in the Bay.
26. A sailing vessel used to harvest oysters.
27. Microscopic life in the ocean.

## BENTHIC BINGO

This is an activity for vocabulary reinforcement. The game is played as a conventional Bingo game. A master is included so that cards may be run off and passed out to the class, who will make up their own cards from lists written on the board. They should be warned to randomize them so that their cards will be different. Slips of paper for each word should be prepared for pulling and calling during the game. Students may use paper scraps to cover their words as they are called. Rewards for the winner may be worked out as the teacher sees fit.

### Word List for the Board

aquaculture	estuary	mollusk	salinity	spatset
benthic	filter feeder	MSX	seed	spawning
bivalve	fungus	parasite	shellfish	subtidal
coliform	glycogen	patent tong	shuck	tong
competitor	gonadal	pathogenic	shucker	tributary
cultch	gregarious	pelagic	silt	turbidity
Dermo	hermaphrodite	plankton	siltation	umbo
dissolved	mariculture	predator	skipjack	veliger
dredge	metamorphose	protozoan	spat	
effluent	middens	recruitment	spatfall	

B

I

N

G

O

B

I

N

G

O

**Resource Material**



## RESOURCE LIST

The following people, places, and things may be drawn upon for additional activities:

Gordon Hallock  
Seafood Marketing Authority  
Kerry Muse  
Division of Market Development  
Department of Economic and Community Development  
1748 Forest Drive  
Annapolis, Maryland 21401

(301) 269-3461

They will send a packet of free material to the teacher with hand-outs for students on recipes, food preparation, and shopping for oysters. They will also welcome a field trip to their facilities in Annapolis. Two free 16mm films are available from the Authority by written request. A 20 minute color film, "The Hidden Treasure of Chesapeake Bay," covers the various methods of harvesting the oyster, shucking and processing, life cycle, and the conservation program in Maryland. The second film, "His Royal Highness, the Maryland Crab," is 13 minutes long. This film covers catching, cooking, picking the meat, and packing. It also covers biology of the crab, sport crabbing, and the crab feast.

Tony P. Mazzaccaro  
Marine Advisory Program Coordinator  
Cooperative Extension Service/Maryland Sea Grant  
University of Maryland  
Symons Hall  
College Park, Maryland 20742

(301) 454-4190

Mr. Mazzaccaro is willing to come to the school, with oysters, to teach the class how to shuck oysters and clams, how to pick a crab, how to dress a fish, even how to fish. Mr. Mazzaccaro is very interested in the role of sportfishing in the Bay and is eager to share his enthusiasm and knowledge. His visit could be the highlight of the whole unit.

If possible, a field trip could be arranged to the Eastern Shore, including the Chesapeake Bay Hydraulic Model on Kent Island, the Seafood

Products Lab at Crisfield, or the museum at St. Michaels. The University of Maryland has a Center for Environmental and Estuarine Studies lab at Solomons Island, also the home of the Calvert County Marine Museum.

The Chesapeake Bay Foundation  
Prince George Street  
Annapolis, Maryland 21401

(301) 269-0481

The Chesapeake Bay Foundation has an educational program for junior high and high school. You may call and arrange for a day's study at their Meredith Creek Educational Center at 268-8816. Located off Whitehall Bay just outside Annapolis, this center features land and water studies dealing with the importance of the Bay. Exciting hands-on experiences are provided for no more than 30 (check with them) students, free. They send a packet of information for the teacher to use to prepare the class for the trip.

Charles County Community College has a program available at their Benedict Field Station on the ecology and biology of the Chesapeake Bay. The program consists of two one-day sessions at \$1.00 per student per day. The fall session covers physical and chemical parameters, migrating waterfowl, and Bay-area animals. The spring session covers the fisheries, the marsh, and attached organisms--the oyster in particular.

For a list of dates available, write or call:

Mr. Tom Pie  
Charles County Community College  
Benedict Field Station  
Benedict, Maryland 20612

(301) 274-3107

A packet of information for the teacher to use to prepare the class for the trip will be sent.

## BIBLIOGRAPHY

- Beaven, G.F. 1954. "The Maryland Oyster Fishery." Natural Resources Institute, University of Maryland, Chesapeake Biological Lab. Extract from the Maryland Tidewater News. Vol. 11, No. 5.
- Bodine, A. Aubrey. 1967. Chesapeake Bay and Tidewater. Bodine and Associates, Inc., Baltimore, Md.
- Breese, Wilbur P. and William Q. Wick. 1974. Oyster Farming, Culturing, Harvesting, and Processing--A Product of the Pacific Coast Area. Oregon State University Extension Marine Advisory Program. SG Number 13, Marine Science Education Publication.
- Chesapeake Bay Oyster Recipes. Seafood Marketing Authority. Division of Market Development, Department of Economic and Community Development. Annapolis, Md.
- Fincham, Michael W. 1978. "Courts May Ban Residency Laws for Oystermen." Maryland Sea Grant Newsletter, University of Maryland, Vol. 1, No. 5.
1978. "Oyster Processors Need New Products." Maryland Sea Grant Newsletter, University of Maryland, Vol. 1, No. 3.
1978. "The Oyster Slump: The Search for Causes." Maryland Sea Grant Newsletter, University of Maryland, Vol. 1, No. 2.
- Galtzoff, Paul. 1964. The American Oyster, Fish. Bulletin. Vol. 64, USDI.
- Lippson, Alice Jane. 1973. The Chesapeake Bay in Maryland. An Atlas of Natural Resources. Johns Hopkins University Press. Baltimore.
- Meritt, Donald W. 1977. "Oyster Spat Set on Natural Cultch in the Maryland Portion of the Chesapeake Bay (1939-1975)." University of Maryland Center for Environmental and Estuarine Studies Special Report No. 7.
- Sherwood, Arthur W. 1973. Understanding the Chesapeake. Tidewater Publishers, Cambridge, Maryland.
- Sieling, Fred. W. The Maryland Oyster. State of Maryland Department of Natural Resources Public Information Services. PS-631.



### Correlation with Existing Texts

This mini-course on the oyster in the Chesapeake Bay could fit into the following texts:

Cambridge, Lab Inquiry Text

Groups of Living Things--classification activity

Harcourt Brace and World, Life a Biological Science

Chapter 13, Mollusks

Houghton Mifflin Co., Spaceship Earth Life Science

Chapter 5 Classification --classification activity

Laidlaw, The Biological Sciences

Chapter 11

McGraw-Hill, Challenges to Science: Life Sciences

Chapter 5 Classification

In addition to direct correlations with specific science texts, this mini-course could be used as a small interdisciplinary unit involving a social studies class, science class, math class, and home economics class. Social studies topics would include the commercial value of the Bay, pollution problems and legislation affecting the Bay, the watermen's vanishing way of life, and the decline of shellfish shucking as an occupation. The activity on graph interpretation, "Production of Oysters in Chesapeake Bay," could be a one-day math activity. Finally, the home economics class can be actively involved in the activity, "Let's Make Oyster Stew." The Seafood Marketing Authority in Annapolis (see Resource List) has a packet of materials for teachers and students on recipes, food preparation, and marketing, as well as two free filmstrips.