



# Lake Layers: Stratification

Chris Brothers, David A. Culver, & Rosanne W. Fortner

The Ohio State University

**CIRCULATING COPY**  
**Sea Grant Depository**

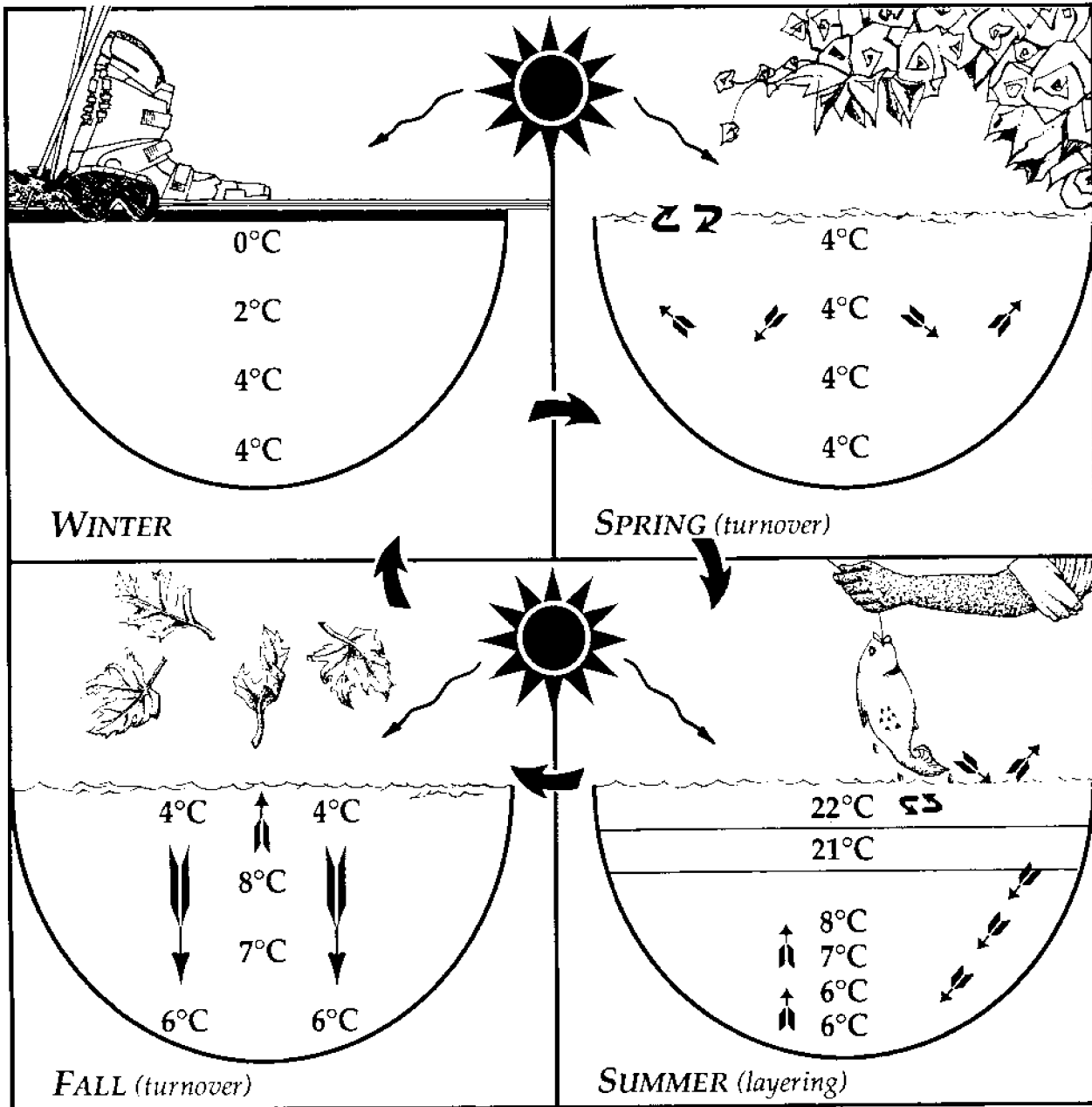



**OEAGLS EP-028T**  
**Teacher Guide**  
Completed December 1991

---

This instructional activity was prepared by project E/AID-2, OSURF Account 722670. Ohio Sea Grant College Program is partially supported through grant NA90AA-D-SG496 from the National Sea Grant College Program of the National Oceanic and Atmospheric Administration (NOAA), U.S. Department of Commerce. Support is provided by the Ohio Board of Regents, The Ohio State University, other participating universities, and industries. Funding support was also provided by The Ohio State University's School of Natural Resources and College of Education. Any opinions, findings, conclusions, or recommendations expressed herein are those of the authors, and do not necessarily reflect the views of NOAA or the University.

---

**Activity A** was adapted from:

- Vallentyne, J. R. 1967. A simplified model of a lake for instructional use. *Journal of Fisheries Research Board of Canada*. 24:2473-9, and  
Foley, Arlene F. 1984. "Summer Stratification and Fall Overturn —In a Jar," *Journal of College Science Teaching*, Sept. - Oct., 1984.

**Ohio Sea Grant Education**  
The Ohio State University  
059 Ramseyer Hall  
29 West Woodruff Avenue  
Columbus, OH 43210  
614/292-1078

**Ohio Sea Grant College Program**  
The Ohio State University  
1314 Kinnear Road  
Columbus, OH 43212-1194  
614/292-8949

Rosanne W. Fortner, *Education Program Director*  
Victor J. Mayer, *Research Coordinator*  
Lorien Marshall, *Initial Layout Editor*  
Suzanne Abbati, *Final Layout Designer and Illustrator*  
Maran Brainard, *Production Coordinator*

---

Copyright © 1991 by The Ohio State University Research Foundation.

The U.S. Government is authorized to produce and distribute reprints for governmental purposes notwithstanding any copyright notation that may appear hereon.



# LAKE LAYERS: STRATIFICATION (EP-028T)

## Teacher Guide\*

By Chris Brothers, David A. Culver, and Rosanne W. Fortner  
The Ohio State University

### Overview:

In this investigation, students will model the seasonal temperature changes that occur in temperate lakes and observe the resulting stratification (layering) of lake waters. Students will then relate stratification of Lake Erie to water quality within the lake.

### Prerequisite Student Background:

Students should be able to record data in chart form and prepare graphs of temperature versus depth (examples are provided). They should be able to use a scale to weigh a flask of water, to read thermometers, and to measure with rulers. They should be somewhat familiar with perimeter and area.

### Objectives:

When the students have completed this investigation they should be able to:

1. describe how water temperature affects water density;
2. explain how changes in water temperature and density cause stratification of lake waters;
3. describe how stratification of lake waters can influence water quality; and
4. explain how phosphorus affects oxygen levels in lakes.

### Materials:

**Activity A:** An aquarium (approximately 40.0 x 20 x 25 cm) containing cold tap water, sieve or aquarium net, several pounds of ice, heat lamp, seven thermometers, small rubber bands, two plastic rulers, masking tape, small fan, food coloring, 300 ml flask, 300 ml beaker, colored ice (with food coloring added before freezing). Students **must** wear safety glasses during this activity. **Activity B:** Worksheets and diagrams of anoxic areas in Lake Erie, ruler, string. **Activity C:** a ruler and string.

### Suggested Approach:

**Activity A:** Set up the aquarium, heat lamps, and thermometers before the class period. Attach the thermometers with rubber bands horizontally across the pair of rulers at depths of 1, 3, 5, 9, 13, 17, and 21 cm. Suspend the rulers with attached thermometers vertically in the aquarium and secure with masking tape to the front of the aquarium (see diagram). The heat lamp should be located directly over the middle of the aquarium, 20 - 25 cm above the water surface you will need to adjust this height for the lamp that you use. The colored ice will also need to be prepared ahead of time. For activity A, students may work in groups of varying sizes depending on the availability of supplies. Optimum group size is three to five students. This activity will take approximately one hour. **Activity B:** Students can work on this activity as individuals or in small groups. The question sheets may be completed in class, as a homework assignment, or as a class discussion. Activity B should take approximately 45 minutes.

\*Note: Information for teachers is enclosed in boxes in this guide.

# LAKE LAYERS: STRATIFICATION (EP-028T)

## Teacher Guide

By Chris Brothers, David A. Culver, and Rosanne W. Fortner  
The Ohio State University

### Introduction:

Have you ever been swimming in the ocean or a lake and stepped into a deep area where the water was much colder? Why does colder water stay near the bottom of a lake? Every year, deep lakes in the *temperate* zones of the world go through water temperature changes as the seasons change. In the Great Lakes, the water may go from an icy winter condition to temperatures as high as 24°C (75°F) or more. What is occurring in the lake when this happens, and how are the plants and animals in the lake affected?

### Objectives:

When you have completed this investigation you should be able to:

1. describe how water temperature affects water density;
2. explain how changes in water temperature and density cause stratification of lake waters;
3. describe how stratification of lake waters influences water quality; and
4. explain how phosphorus affects oxygen levels in lakes.

### Aquarium Setup

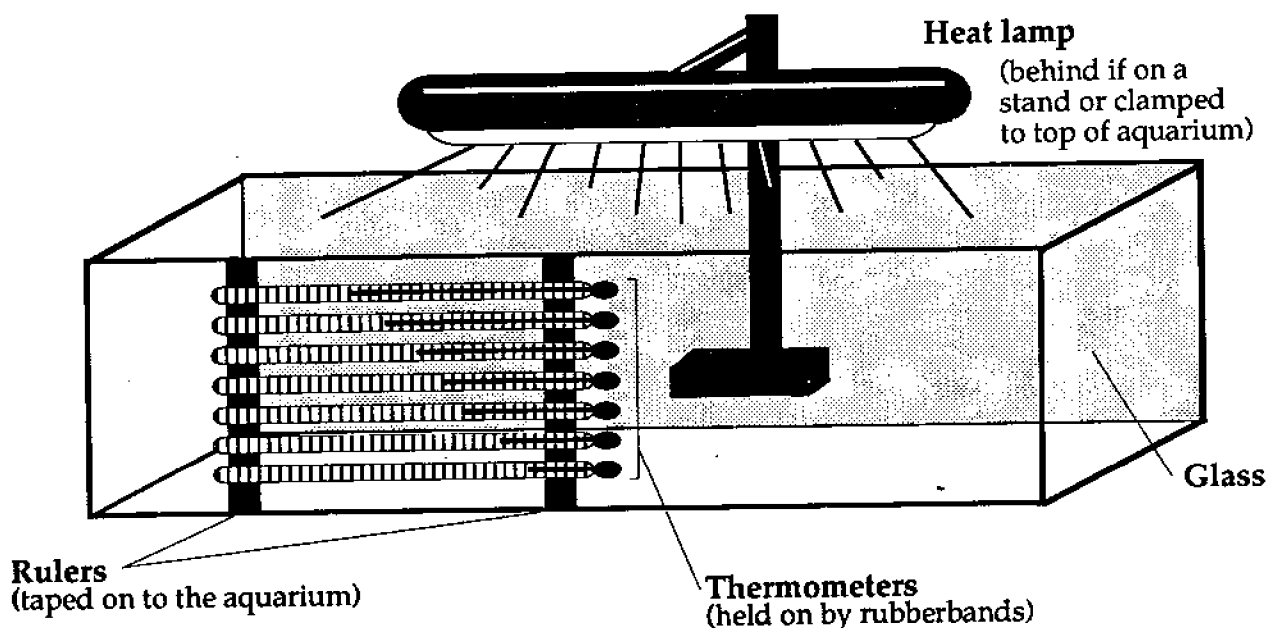

## Activity A: How do the Great Lakes change through the seasons?

### Materials:

An aquarium containing cold tap water, sieve or aquarium net, ice, heat lamp, seven thermometers, rubber bands, two plastic rulers, masking tape, small fan, food coloring, 300 ml flask, 300 ml beaker, colored ice (frozen with food coloring added). **Safety glasses must be worn at all times during this activity.**

### Procedure:

A. Add enough ice, stirring occasionally, to the aquarium to lower the temperature of the water to 4°C. You should still have a shallow layer of ice on the surface where the temperature will be 0°C. Allow the water to come to rest. In the first column of the temperature data chart on your worksheet, record the temperatures of the seven thermometers.

B. Remove the rest of the ice with a sieve or aquarium net as gently as possible. Turn on the heat lamp. **Be very careful not to splash any water on the heat lamp or it will explode.** Record this time as the beginning of the experiment.

C. After 5 minutes, record the temperatures of each of the seven thermometers in the second column of your data chart.

D. As you wait for the 5 minutes to pass, graph depth in cm versus temperature in °C on graph #1 using the data from column #1. What time of year do these temperatures represent? Label the graph with the time of year.

This represents winter before the spring turnover. Temperature at most depths should be about 4°C with the surface water at about 0°C.

E. At the 12 minute mark, record the temperatures on the seven thermometers in the third column of your data chart. Record the water temperatures again at the 30 minute and 45 minute marks in the fourth and fifth columns of your data chart.

A better simulation of seasons and layers can be achieved by blowing a fan or low powered hair dryer across the surface while the lamp is on. The warmth of the surface layer will be distributed to a depth of several centimeters.

- F. While you wait, pour 250 ml of ice water into a 300 ml flask. Weigh the flask.
1. What is the temperature and weight of this water?

Answers will vary depending on the temperature of the water.

- G. Empty the flask and refill it with 250 ml of very hot tap water. Weigh the flask with the hot water and record its weight.
2. What is the temperature and weight of this water?

Answers will vary depending on the temperature of the water.

3. Which temperature of water weighs more?

The cold water weighs more. The actual difference measured will be very low, however (perhaps 2 g. difference, depending on the accuracy of volume measurements.) If student level is lower or the equipment is not sophisticated, it may not be possible to detect differences in density this way. Water is most dense at 4°C. It becomes less dense as temperature increase from 4°C. It also becomes less dense as temperatures decrease from 4°C to 0°C, at which point it freezes. This is why warm layers of water rest on top of cold layers during the summer and why cold water sinks in the fall during fall turnover.

- H. Pour the hot water into a beaker or glass jar. Gently add a few colored ice cubes to the hot water.

4. What happens to the colored water from the ice as the ice melts? Why?

Ice floats on water because it is less dense than water. As the ice melts, its colored water will sink because it is colder than the warm tap water. Eventually a cold layer of water will form at the bottom of the warm water, illustrating the stratification that occurs in lakes.

Spring turnover occurs when water temperatures at the surface are equal to those at lower depths and water from all depths mixes. The top layers of water may then start to warm slightly.

- I. Which column of temperature data best represents spring turnover in your model lake? Use the data from this column to graph depth in cm versus temperature in °C on graph #2. Label this graph "spring turnover."

The data in column two probably best represent spring turnover. The temperatures should be the same over all depths or slightly warmer at the surface.

As summer approaches, the lake continues to warm.

5. Why do surface temperatures increase during the summer while water temperatures at lower depths remain cold?

Surface temperatures increase from warming by the sun and from the surrounding air. Not as much sunlight reaches the lower depths, thus these areas are not warmed as much.

During the summer, the lake becomes stratified into three layers of water—the warm upper layer or epilimnion (epi = upon or above), the cold bottom layer or hypolimnion (hypo = lower or below), and the middle layer of rapid temperature change known as the metalimnion (meta = middle).

- J. Which temperature data column best represents the stratified summer lake? Use the data

from this column to graph depth in cm versus temperature in °C on graph #3. What season should you label this graph?

Data in column five best represent the stratified summer lake. Temperatures will be warmest at the surface, coldest at the bottom, and may show a sharp drop at some depth in between. This sharp drop occurs at the metalimnion. This graph should be labeled "summer stratification."

6. What is the temperature in the epilimnion? In the hypolimnion? How much temperature difference is there between these two layers?

Temperatures in the epilimnion (surface) may be 20°C or higher. Temperatures in the hypolimnion (bottom) may be about 5-8°C. Temperature differences may be 15°C or more.

When temperature layers form in the lake in the summer the warm surface water (epilimnion) is separated from the cold bottom water (hypolimnion) by the metalimnion. Temperature is not the only factor that is different among the layers. Oxygen dissolves better in cold water than in warm water, but it is getting used up by living things all the time. Wind at the surface of the lake creates waves and stirs up the water, adding oxygen to it in the same way a bubbler works in a fish tank. The metalimnion acts as a barrier. It keeps oxygen in the surface waters from reaching the colder waters of the hypolimnion. Gradually, the oxygen in the hypolimnion can get used up.

Sample of Water Temperature Data Chart °C

Depth in cm	Time Columns						
	#1	#2	#3	#4	#5	#6	#7
1	0	8	10	13	15	13	7
3	4	7	9	12	15	13	7
5	4	6	7	8	9	9	7
9	4	6	6	7	7	7	7
13	4	6	6	7	7	7	7
17	4	6	6	6	7	7	7
21	4	6	6	6	6	6	7

7. What happens to the animals living at the bottom of the lake when there is no oxygen?

These animals may die from lack of oxygen or may be forced to move to areas of the lake where there is more oxygen (surface or near shore waters.)

As autumn begins, the surface waters of the lake begin to cool.

K. Turn off the heat lamp. Turn on the fan and use it to create a strong wind by blowing on the water from one direction. Keep blowing until all the water in the lake is completely mixed. Record the water temperatures in the sixth column of your data chart.

8. Why do surface waters of the lake cool off during the fall?

Surface water temperatures cool during the fall as less sunlight reaches and warms them. In addition, air over the lake is cooler and the lake gives up heat to the air.

Fall turnover occurs when all the lake water has cooled and has been completely mixed by water movements and wind.

9. How might fall turnover be good for animals living at the bottom of the lake?

Fall turnover mixes the water in the lake. This mixing resupplies oxygen and other nutrients needed by animals and plants to all depths in the lake.

10. What seasonal change in lake temperatures has happened in the fall? Are there any temperature layers in the lake once the water has mixed?

Fall turnover has occurred. There should be no temperature layers in the lake — temperatures should be fairly similar at all depths.

L. Carefully add ice to the surface water to create an ice layer. Try not to mix or disturb the water. Record the water temperatures in the last column of your data chart.

11. What time of year is represented by these temperature data in the last column?

These temperature data represent late fall as water temperatures cool and ice starts to form on the lake.

M. Use the data from the last column to graph depth in cm versus temperature in °C on graph #4. What should this graph be labeled?

This graph should be labeled "fall turnover" or "late fall."

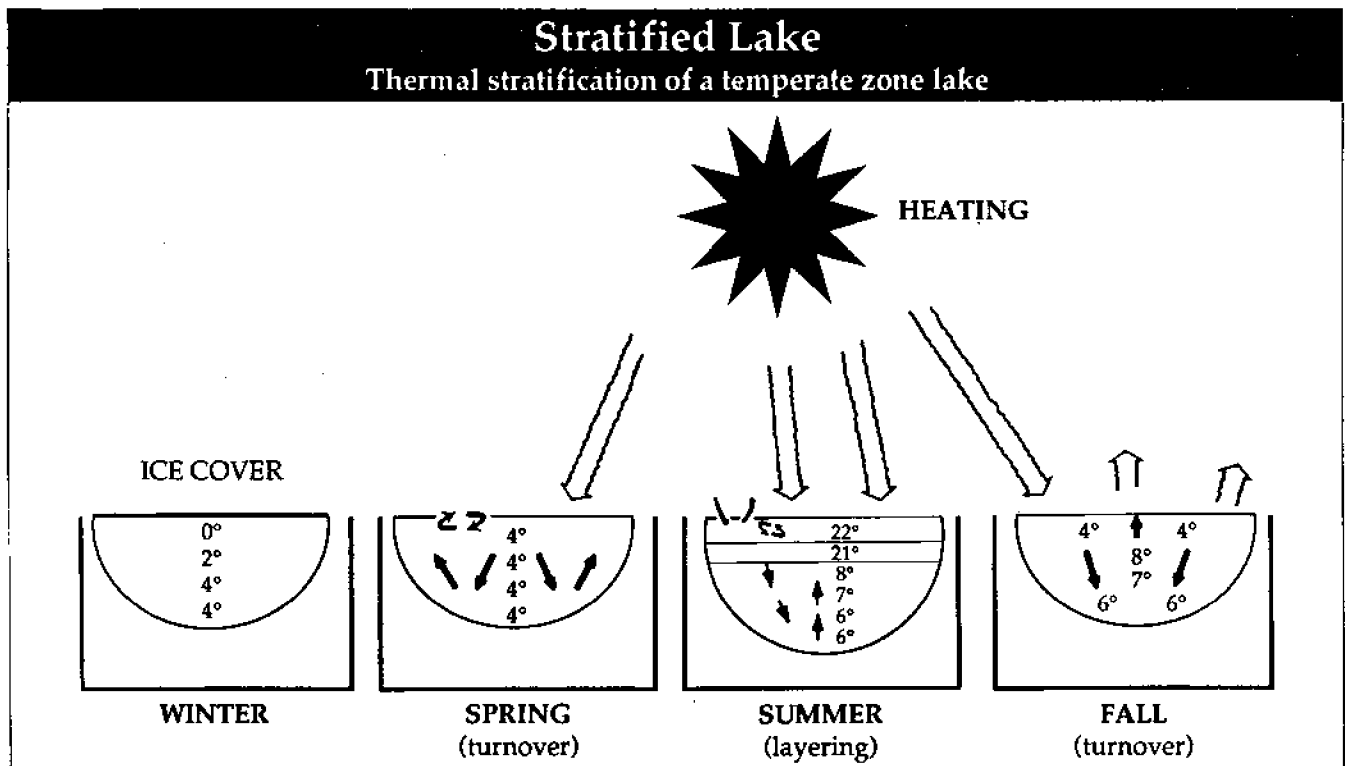

## Activity B: How does stratification affect water quality?

Some of Lake Erie's water quality problems have been related to the layering of the lake's waters, which occurs in the summer months. During the summer, the warm surface layer of water does not mix with the colder bottom layer of water. If a lot of algae has grown in the lake, decay of the dead algae on the lake bottom may use up all of the oxygen in the cold bottom water layer. When there is no oxygen in the bottom waters, the water is said to be **anoxic**. Fish and other animals cannot live in these anoxic waters. In the fall, the surface water cools and mixes with the bottom water, resupplying the bottom water with oxygen needed for life.

### Materials:

Worksheet and diagrams of anoxic areas in Lake Erie, ruler, string.

### Procedure:

A. Look at the anoxia diagrams of Lake Erie on your worksheet. The shaded area on each diagram shows the part of the lake bottom that was anoxic that year. These parts of the lake contained no oxygen in the hypolimnion.

1. In which year do you think the lake had the largest anoxic area? In which year does the lake seem to have had the smallest anoxic area?

The lake had the largest anoxic area in 1973. The smallest anoxic area occurred in 1930.

B. On an enlarged diagram from your teacher use the string and ruler method to measure the perimeter of the anoxic part of the lake in 1930. Stretch the string all the way around the perimeter (outer edge) of the shaded anoxic part. Then stretch the string along the ruler to measure its length in cm. The length of the string is equal to the perimeter of the anoxic part of the lake. You may want to tape the string in place at your starting point or mark your starting point with your pencil.

2. What was the perimeter of the anoxic section in 1930?

The perimeter of the anoxic section is 4 cm.

C. Repeat step 2 for the enlarged diagrams of the lake in 1964, 1973, 1976, and 1982. Enter the perimeter of the anoxic part of the lake for each year in the chart on your worksheet.

D. Using the steps for finding the area of a circle from its circumference, find the area of the anoxic section of the lake from its perimeter. The formula you should use is  $A=C^2/4\pi$  ( $\pi=3.14$ ).

Although the anoxic section is not a perfect circle in shape, we will use this method to estimate the area of the anoxic part of the lake from the perimeter you measured. Enter the area of the anoxic part of the lake for each year in the chart on your worksheet.

3. In which year did the lake have the largest anoxic area? In which year did it have the smallest anoxic area? How do these results compare to your earlier predictions?

The lake had the largest anoxic area in 1973. The smallest anoxic area occurred in 1930.

E. Look at the map of Lake Erie divided into its three geographic basins: the Eastern, Central, and Western basins. Match the basins on this map with your map of the lake showing anoxic areas.

4. In which basin of the lake are the anoxic areas found?

Anoxic areas are found in the Central Basin. The small black dots in the Western Basin are islands, not anoxic areas.

5. Looking at the map of Lake Erie divided into basins, what is the average depth in each of the three basins?

Average depth in the lake in the Eastern Basin is 80 feet (24 meters), the Central Basin, 60 ft. (18m), and the Western Basin, 24 ft. (7m).

Usually only large lakes that are deeper than 40 feet or 12 meters stratify into temperature layers during the summer.



# Three Basins of Lake Erie

(Adapted from Department of the Interior, "Lake Erie Report," Washington, D.C., 1968)

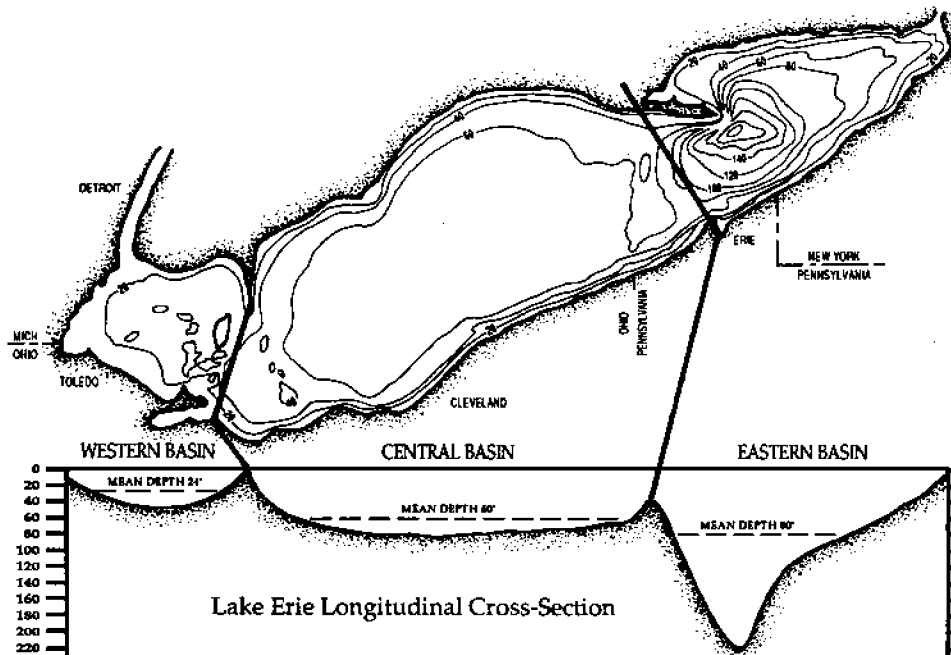

6. Which of the three basins in Lake Erie will stratify in the summer?

The Eastern and Central Basin will stratify.

7. Does the Western Basin stratify during the summer? Why or why not? Will it become anoxic?

The Western Basin does not become anoxic because it does not stratify. It is shallow enough that oxygen is continually mixed and supplied to all depths of the lake by wind and wave action.

8. Is the Central Basin deeper or shallower than the Eastern Basin? Which of the two basins will have warmer bottom waters? Which of the two basins will have less oxygen in its bottom waters at the beginning of the summer? Which of the two basins is more likely to become anoxic?

The Central Basin is shallower than the Eastern one, its bottom waters are warmer, and these waters contain less oxygen at the beginning of the summer. The hypolimnion may only be about 1 m. deep. Thus, the Central Basin is more likely to become anoxic.

Although the Eastern Basin stratifies during the summer, it does not become anoxic. This is because

it is so deep. Deep waters are cold, while shallow waters are warm. Cold water can hold much more oxygen than warm water can.

The supply of oxygen in the cold waters of the Eastern Basin at the beginning of the summer is high. Oxygen at the bottom of the lake is used throughout the summer by animals living there and in the decay of dead algae. Stratification of the lake's waters prevents more oxygen from reaching the bottom water. Even so, the oxygen supply in the Eastern Basin does not get used up during the summer, because the supply was very high at the beginning of the summer, and because the hypolimnion is much thicker in the Eastern Basin than it is in the Central Basin.

9. What might happen to fish and other animals living in the Central Basin when it becomes anoxic?

Fish and other animals cannot live in anoxic waters. They may die from suffocation or they may move to areas of the lake that still contain oxygen. There may be a change in the kinds of fish living in the lake from species needing cold, high oxygen waters (trout and whitefish) to fish that can survive in warmer waters with less oxygen (carp).

The farm fertilizers and the laundry detergents we use both contain a chemical called **phosphorus**. When fertilizers from farms or sewage containing detergents flow into a lake, phosphorus enters the lake as well. Phosphorus is a **nutrient** needed by all plants, including algae, to grow. When a large amount of phosphorus enters a lake, it may cause algae to grow very rapidly. The result may be too much algae. The algae may use up the dissolved oxygen (D.O.) in the water, both through their own growth and as they decay.

10. What happens to the lake when growth and decay of algae uses up all the oxygen?

The lake becomes anoxic.

People started putting phosphorus into detergents in the late 1950s. Before that, phosphorus was not used in detergents.

11. How would you now explain the large anoxic areas that occurred in Lake Erie during the 1970s? How can you explain the smaller anoxic areas that occurred in 1930 and 1964?

Large anoxic areas in the 1970s probably resulted from large amounts of phosphorus from laundry detergents entering the lake. In 1970 half of the phosphorus in sewage came from laundry detergents. The smaller anoxic areas in 1930 occurred before phosphates came into use. Although phosphates were being used by 1960, not as much phosphorus had entered the lake by 1960 as it had by the 1970s.

In 1978, laws were passed by many states in the

Great Lakes Basin to limit the amount of phosphorus that could be used in detergents.

12. Why do you think laws banning phosphorus in detergents were passed?

Such laws, called phosphorus bans or limits, were passed to reduce the amount of phosphorus entering the lakes. It was hoped that by reducing the amount of phosphorus entering the lakes, algae growth and anoxic areas could also be reduced.

The amount of phosphorus entering Lake Erie has been reduced nearly 60 percent in the past twenty years.

13. How would you now explain why the size of anoxic areas in the lake seems to have decreased since 1976?

Reducing the amount of phosphorus entering the lake has contributed to a reduction in algae growth in the lake. With less algae growth in the lake, smaller areas of the lake became anoxic during the 1980s.

In January of 1990, the State of Ohio joined other Great Lakes states that have reduced phosphorus in detergents.

14. Predict what will happen to the anoxic area of Lake Erie in the 1990s if phosphorus continues to be reduced in the lake.

As less phosphorus enters Lake Erie, anoxic areas of the lake should decrease in size. However, phosphorus will still be entering Lake Erie from farm runoff and other sources.

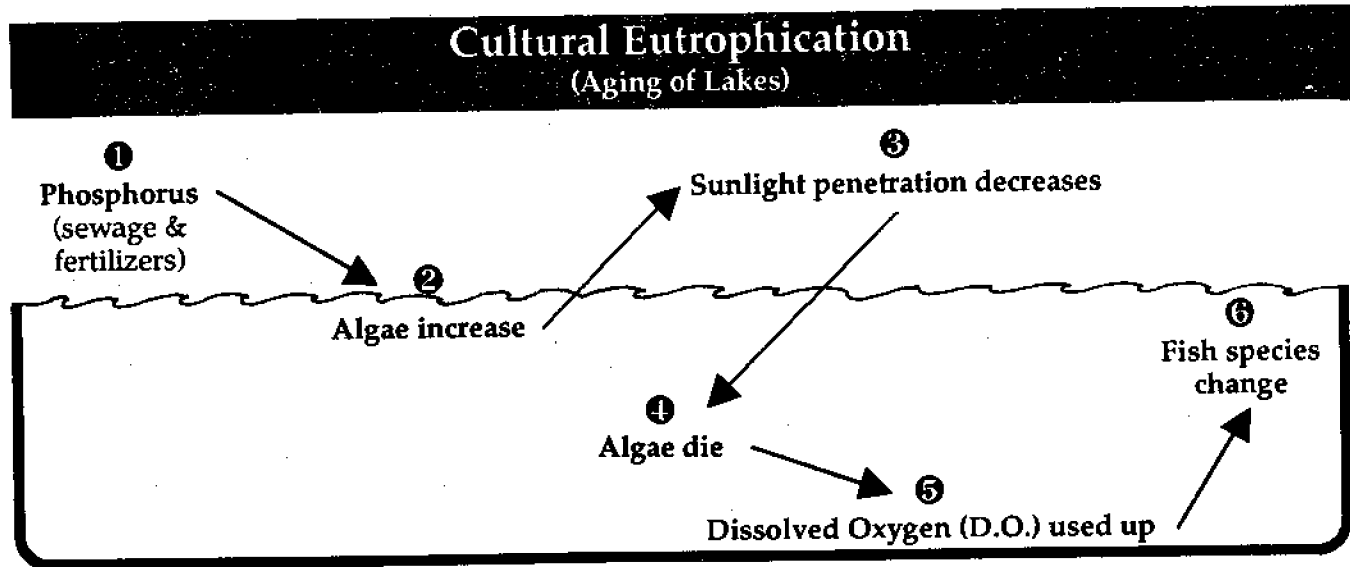

### Ideas for Extension

1. Nutrients in the Great Lakes, OEAGLS activity number EP-29, includes two activities related to eutrophication and water quality in the Great Lakes. Students investigate the impact of nutrients in a lake by observing algae growth in samples of lake water and plot the amounts of nutrients reaching a lake following a storm to learn about the role of wetlands in improving water quality.
2. Have students check the phosphorus content of the detergents their families use. Most brands include this information in the list of ingredients. Which detergents contain the most and the least amounts of phosphorus?
3. Have students research the farming practices used in their area. What is no-till agriculture? Are any farmers using it? What are the advantages and disadvantages of no-till? Students could interview farmers or county Soil and Water Conservation District staff to find out.

### Suggested References

- Herdendorf, Charles E. "Recovering from Phosphorus Enrichment." *The Great Lake Erie*, Rosanne W. Fortner and Victor J. Mayer, editors. The Ohio State University Research Foundation, 1987.
- Oglesby, Ray T. "Lakes Which Produce Too Much." *The Conservationist*. June-July, 1970.
- Reutter, Jeffrey M., Frank R. Lichtkoppler, and Charles E. Herdendorf. "Lake Erie: Phosphorus and Eutrophication." Ohio Sea Grant Fact Sheet # 15.
- Vallentyne, John R. *The Algal Bowl: Lakes and Man*. Department of the Environment Fisheries and Marine Service, Ottawa, Canada, 1974.

## Review Questions

1. How does water temperature affect water density?

Colder water is denser and heavier than warmer water.

2. When water is stratified in a lake, where is the colder water found? Why?

In a lake, cold water is denser and will sink while warm water is less dense and will "float" on top of the cold water. Therefore, the cold water will be found at the bottom of the lake.

3. What are the names given to the three layers of water that form when a lake is stratified?

Epilimnion, hypolimnion, and metalimnion.

4. How does stratification affect the amount of oxygen found in the bottom of the lake?

When the lake is stratified, the metalimnion acts as a barrier keeping water from mixing and oxygen from reaching the hypolimnion. Oxygen in the hypolimnion may get used up, resulting in anoxia.

5. Why does the Western Basin of Lake Erie not become anoxic during the summer?

The Western Basin does not stratify during the summer because it is too shallow. Wind and wave action continually mix the water in the lake. Because oxygen is supplied to all depths, the basin does not become anoxic.

6. What are the human-produced sources of phosphorus nutrients entering the lakes?

Phosphorus enters a lake primarily from run-off of fertilizers from farms and from laundry detergents.

7. How does phosphorus contribute to anoxia in Lake Erie?

Phosphorus is a nutrient needed by algae to grow. When phosphorus enters a lake, it acts as a fertilizer, causing algae to grow rapidly. The algae may use up the oxygen in the water both through its own growth and as it decays.

8. Why have Great Lakes states passed laws limiting the amount of phosphorus that can be used in detergents?

Phosphorus limits or bans were passed to reduce the amount of phosphorus entering the lakes and thus reduce algae growth and problems caused by anoxia.

Detergent phosphorus limits (%P) in Great Lakes basin.

Area	%P	Starting Date
Ontario	2.2	1973
Chicago, Ill.	0.5	1972
Indiana	0.5	1973
Michigan	0.5	1977
Minnesota	0.5	1977
New York	0.5	1973
Wisconsin	0.5	1979
Ohio (lake basin)	0.5	1990
Pennsylvania	no limitations	

# Lake Layers: Stratification (EP-028T)

## Answer Sheet

---

### Activity A: How do the Great Lakes change through the seasons?

1. What is the temperature of the ice water in the flask? \_\_\_\_\_  
What is the flask's weight with cold water? \_\_\_\_\_
2. What is the temperature of the hot tap water in the flask? \_\_\_\_\_  
What is the flask's weight with hot tap water? \_\_\_\_\_
3. Which temperature of water is heavier? (compare the flask weights) \_\_\_\_\_
4. What happens to the colored water from the ice as the ice melts? \_\_\_\_\_  
Why? \_\_\_\_\_
5. Why do surface water temperatures increase during the summer while water temperatures at lower depths remain cold?  
\_\_\_\_\_
6. What is the temperature in the epilimnion of your lake? \_\_\_\_\_  
In the hypolimnion? \_\_\_\_\_  
How much temperature difference is there between these two layers? \_\_\_\_\_
7. What happens to the animals living at the bottom of the lake when there is no oxygen?  
\_\_\_\_\_
8. Why do surface water temperatures of the lake cool during the fall? \_\_\_\_\_  
\_\_\_\_\_
9. How might fall turnover be good for animals living at the bottom of the lake? \_\_\_\_\_  
\_\_\_\_\_
10. What seasonal change in lake temperatures has happened in the fall? \_\_\_\_\_  
Are there any temperature layers in the lake once the water has mixed? \_\_\_\_\_
11. What time of year is represented by the temperature data in the last column? \_\_\_\_\_

# Water Temperature Graphs

Graph #1 (from Data Chart column #1)

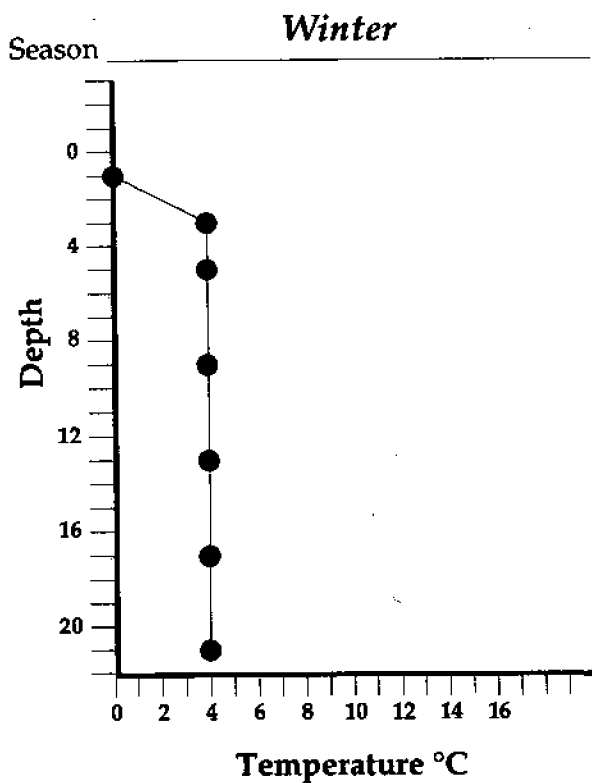

Graph #2 (from Data Chart column #2)

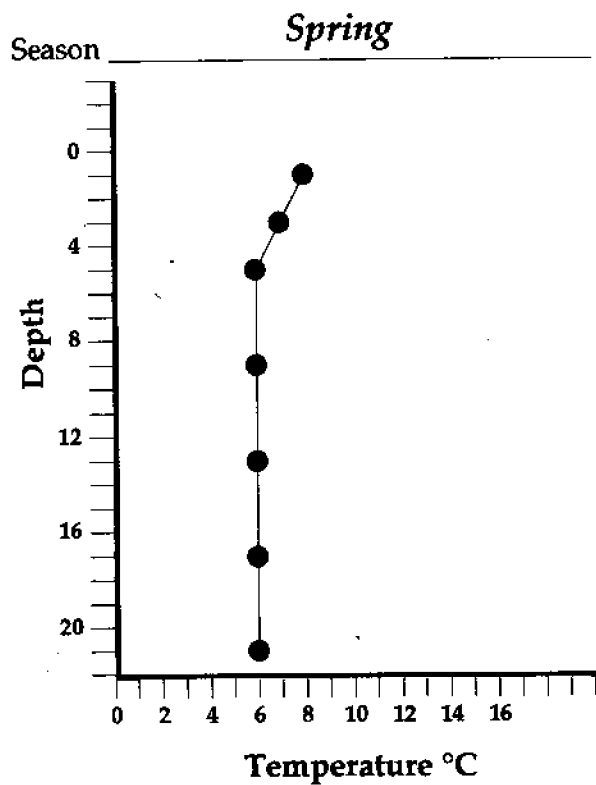

Graph #3 (from Data Chart column #5)

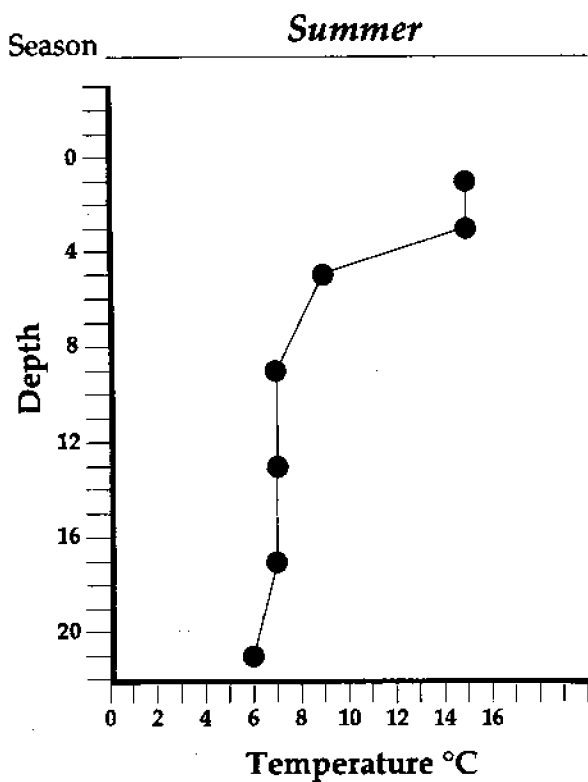

Graph #4 (from Data Chart column #7)

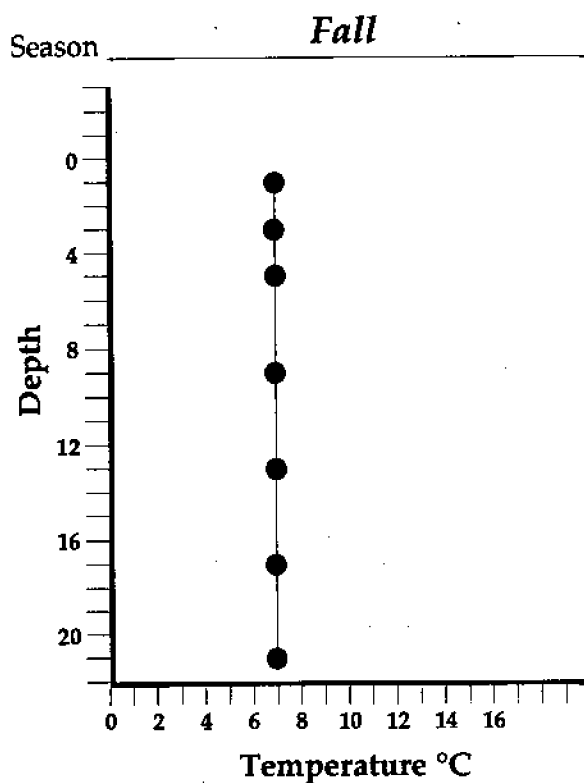

# Lake Layers: Stratification (EP-028T)

## Answer Sheet

### Activity B: How does stratification affect water quality?

1. In which year do you think the lake had the largest anoxic area? \_\_\_\_\_

In which year does the lake seem to have had the smallest anoxic area? \_\_\_\_\_

2. What was the perimeter of the anoxic section in 1930?

YEAR	1930	1964	1973	1976	1982
PERIMETER					
ANOXIC AREA					

3. In which year did the lake have the largest anoxic area? \_\_\_\_\_

In which year did it have the smallest anoxic area? \_\_\_\_\_

How do these results compare to your earlier predictions? \_\_\_\_\_

4. In which basin of the lake are the anoxic areas found? \_\_\_\_\_

5. What is the average or mean depth in each of the three basins?

Eastern \_\_\_\_\_ Central \_\_\_\_\_ Western \_\_\_\_\_

6. Which of the three basins in Lake Erie will stratify in the summer? \_\_\_\_\_

7. Does the Western Basin stratify? \_\_\_\_\_

Why or why not? \_\_\_\_\_

Will it become anoxic? \_\_\_\_\_

8. Is the Central Basin deeper or shallower than the Eastern Basin? \_\_\_\_\_

Which of the two basins will have warmer bottom waters? \_\_\_\_\_

Which of the two basins will have less oxygen in its bottom waters at the beginning of the summer? \_\_\_\_\_

\_\_\_\_\_

Which of the two basins will most likely become anoxic? \_\_\_\_\_

9. What might happen to fish and other animals living in the Central Basin when it becomes anoxic?

---

10. What happens to the lake when growth and decay of the algae uses up all the oxygen? \_\_\_\_\_

---

11. How would you now explain the large anoxic areas that occurred in Lake Erie during the 1970s?

---

---

How can you explain the smaller anoxic areas that occurred in 1930 and 1964? \_\_\_\_\_

---

12. Why do you think laws banning phosphorus in detergents were passed? \_\_\_\_\_

---

13. How would you now explain why the size of anoxic areas in the lake seems to have decreased since 1976? \_\_\_\_\_

---

14. Predict what will happen to the anoxic area of Lake Erie in the 1990s if phosphorus continues to be reduced in the lake. \_\_\_\_\_

---



---

Worksheet for Activity B

---

ince

be

# Anoxia Diagrams of Lake Erie 1930—1982

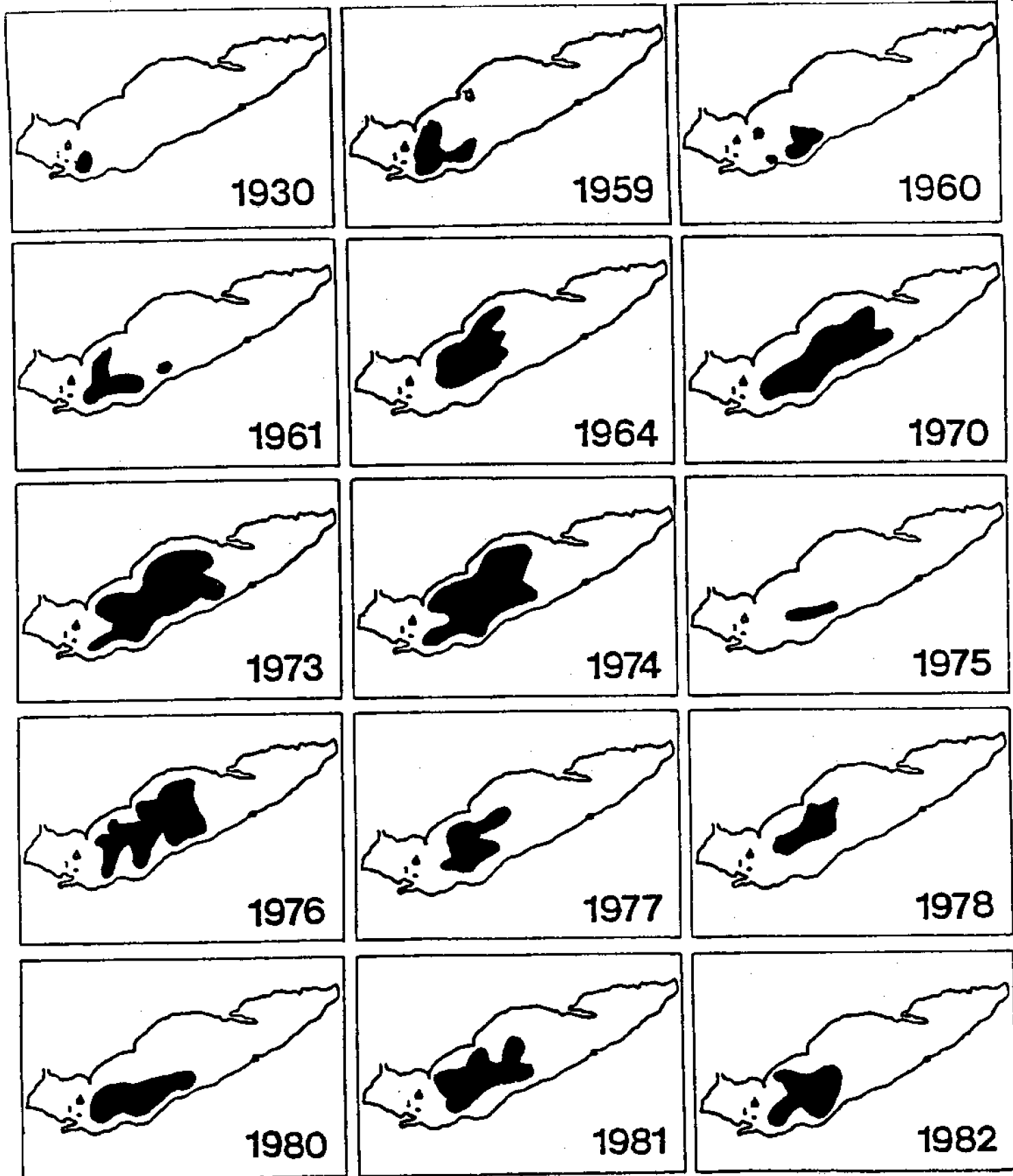

---

Anoxia diagrams of Lake Erie

---

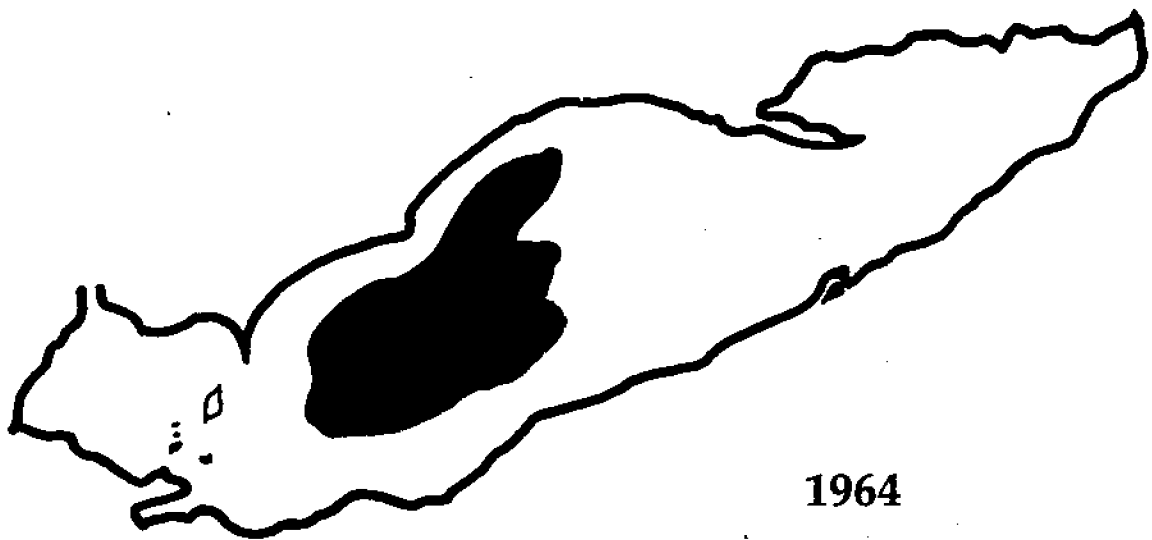
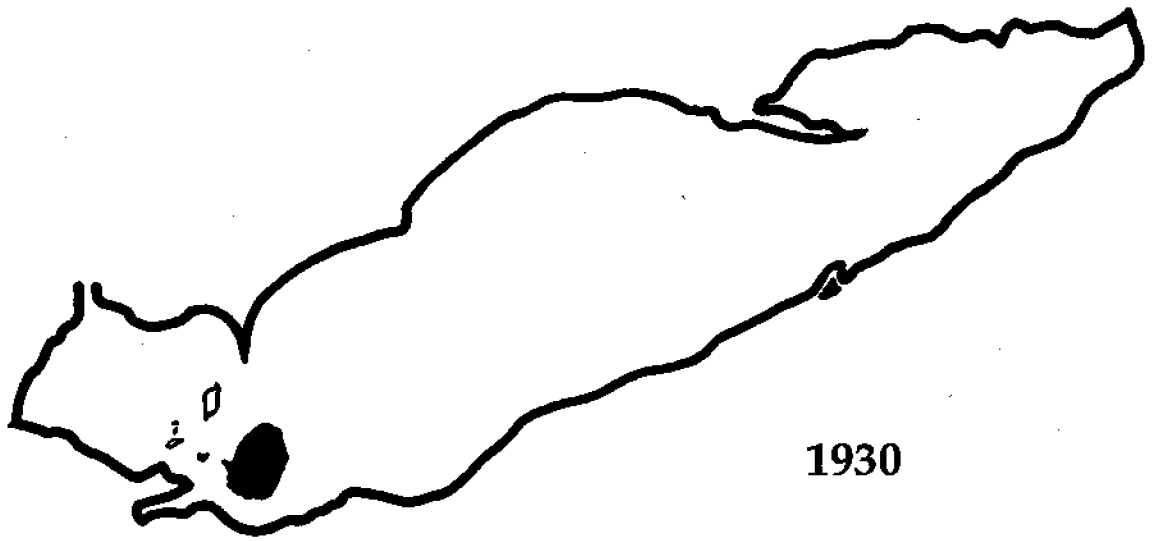

Anoxia diagrams of Lake Erie

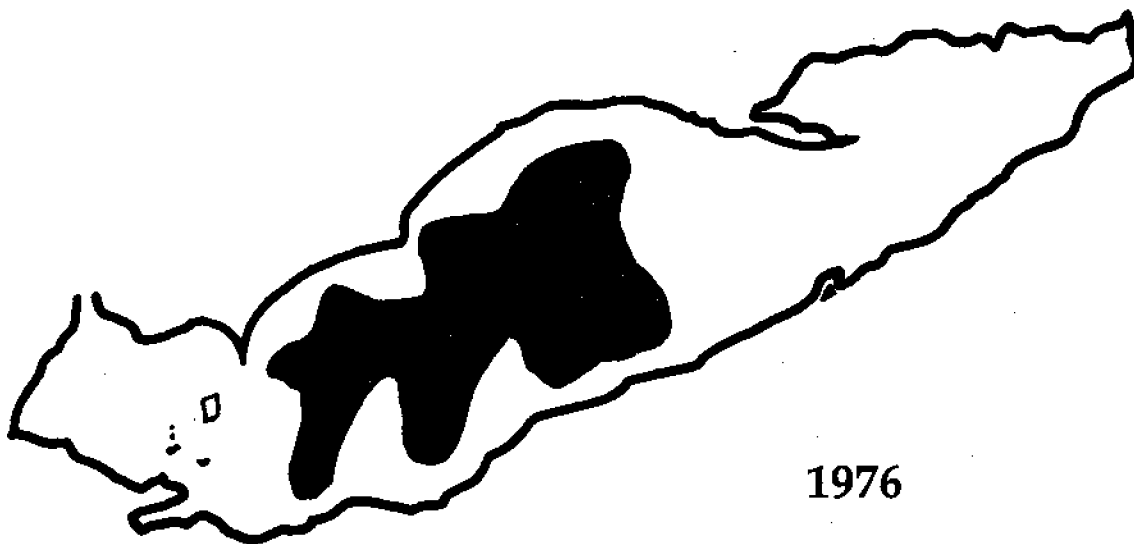
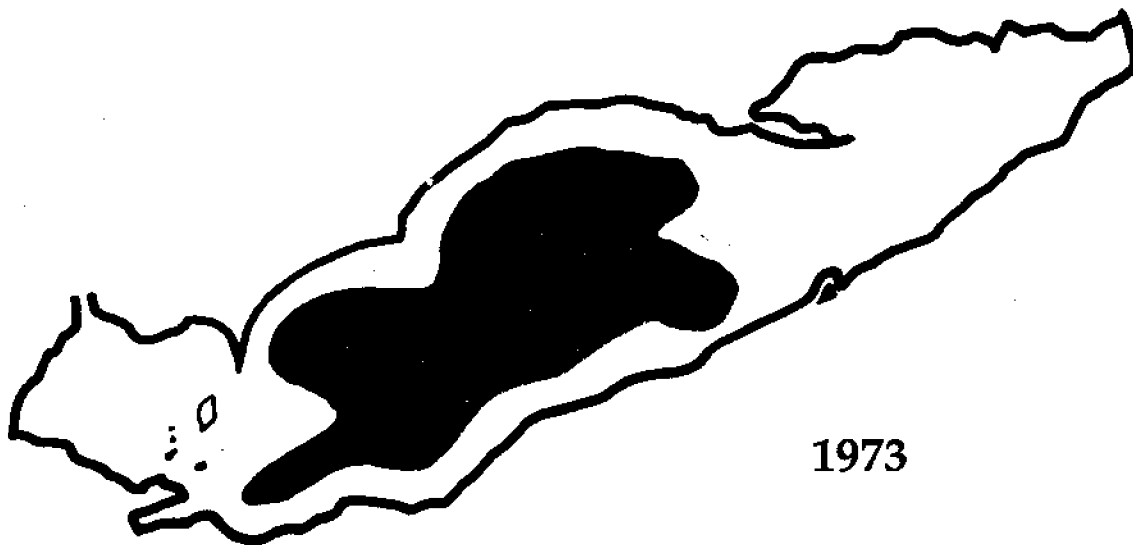

---

Anoxia diagrams of Lake Erie

---

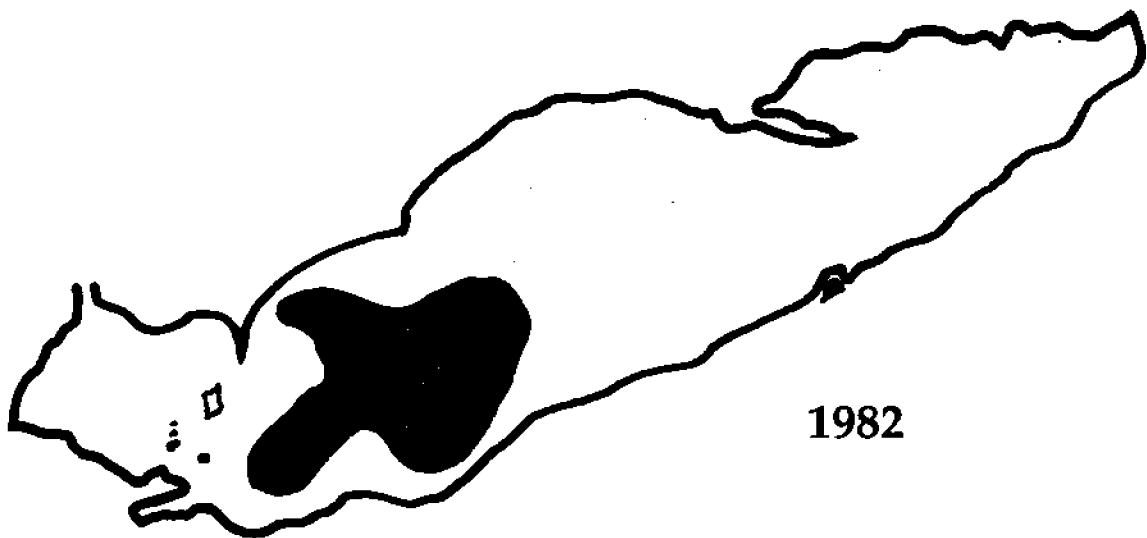

## Oceanic Education Activities for Great Lakes Schools (OEAGLS)

Results of studies of student knowledge about the oceans and Great Lakes environments indicate a need for greater awareness of those environments, and a greater understanding of the impact they have upon the lives of people. OEAGLS (pronounced "eagles") are designed to take a concept or idea from the existing school curriculum and develop it into an oceanic and Great Lakes context, using teaching approaches and materials appropriate for children in grades five through nine.

OEAGLS materials are designed to be easily integrated into existing curricula. Investigations are characterized by subject matter compatibility with existing curriculum topics, short activities lasting from one to three classes, minimal preparation time, minimal equipment needs, standard page size for easy duplication, student workbook plus teacher guide, suggested extension activities for further information or creative expression, teachability demonstrated by use in middle school classrooms; and content accuracy assured by critical reviewers. Each title consists of a student workbook and a teacher guide and costs \$3.00 for the publication, postage, and handling. If ordering EP-026, add an additional \$4.00 to cover the cost of the computer disk.

- |   |   |
|---|---|
| THE EFFECT OF THE GREAT LAKES ON TEMPERATURE (EP-001) | THE ESTUARY: A SPECIAL PLACE (EP-016)     |
| THE EFFECT OF THE GREAT LAKES ON CLIMATE (EP-002)     | THE GREAT LAKES TRIANGLE (EP-017)         |
| ANCIENT SHORES OF LAKE ERIE (EP-003)                  | KNOWING THE ROPES (EP-018)                |
| HOW TO PROTECT A RIVER (EP-004)                       | GETTING TO KNOW YOUR LOCAL FISH (EP-019)  |
| CHANGING LAKE LEVELS (EP-005)                         | SHIPPING: THE WORLD CONNECTION (EP-020)   |
| EROSION ALONG THE GREAT LAKES (EP-006)                | WE HAVE MET THE ENEMY (EP-021)            |
| COASTAL PROCESSES AND EROSION (EP-007)                | IT'S EVERYONE'S SEA: OR IS IT? (EP-022)   |
| POLLUTION IN LAKE ERIE: AN INTRODUCTION (EP-008)      | PCBs IN FISH: A PROBLEM? (EP-023)         |
| YELLOW PERCH IN LAKE ERIE (EP-009)                    | A GREAT LAKES VACATION (EP-024)           |
| EVIDENCE OF ANCIENT SEAS IN OHIO (EP-010)             | STORM SURGES (EP-025)                     |
| TO HARVEST A WALLEYE (EP-011)                         | RIVER TREK with computer program (EP-026) |
| OIL SPILL! (EP-012)                                   | WAVES (EP-027)                            |
| SHIPPING ON THE GREAT LAKES (EP-013)                  | LAKE LAYERS: STRATIFICATION (EP-028)      |
| GEOGRAPHY OF THE GREAT LAKES (EP-014)                 | NUTRIENTS IN THE GREAT LAKES (EP-029)     |
| OHIO CANALS (EP-015)                                  | EATING LIKE A BIRD (EP-030)               |

### OEAGLets

In the primary grade range we have three activities. All use Lake Erie information applied to all primary subject areas. Each title costs \$5.00 for the publication, postage, and handling.

- LAKE ERIE—TAKE A BOW (EP-031)
- BUILD A FISH TO SCALE (EP-032)
- A DAY IN THE LIFE OF A FISH (EP-033)

### COMPUTER PROGRAMS

All programs run on Apple II computer series.

- EP-24/Disk This program is an optional purchase to accompany OEAGLS A GREAT LAKES VACATION. \$4.00
- EP-74/Disk To accompany OEAGLS EP-011, 019, 021, and 023. \$5.00

### ADDITIONAL EDUCATIONAL MATERIALS

SUPPLEMENTAL CURRICULUM ACTIVITIES TO ACCOMPANY HOLLING C. HOLLING'S

- PADDLE-TO-THE-SEA* (EP-076) \$10.00
- ACTIVITIES FROM MIDDLE SEA (EP-071) \$2.50
- WATERWORKS (EP-072) \$2.50
- THE OHIO SEA GRANT EDUCATION PROGRAM: DEVELOPMENT, IMPLEMENTATION, EVALUATION (EP-075) \$8.00
- MARINE EDUCATION BIBLIOGRAPHY \$2.00

### OTHER PUBLICATIONS AVAILABLE

- TWINE LINE* Sea Grant eight-page bimonthly newsletter. \$4.50 for six issues.
- PUBLICATION BROCHURE Free.
- EDUCATION BROCHURE Free.
- TECHNICAL PUBLICATIONS BROCHURE Free.
- SEA GRANT PROGRAM BROCHURE Free.
- GREAT LAKES PURSUIT *S.E. Pflaumer and R.W. Fortner*. A game played like *Trivial Pursuit*® but the questions challenge players to learn about the Great Lakes. \$24.00 (Reduced price available for educators.)
- TOO MUCH MUSSEL 1991. This 5 1/2 minute video (VHS format) provides an overview of the zebra mussel impact to Lake Erie. \$15.00
- GLOBAL CHANGE IN THE GREAT LAKES SCENARIOS 1991. Ten scenarios about global change in the Great Lakes. \$6.00



# Lake Layers: Stratification

Chris Brothers, David A. Culver, & Rosanne W. Fortner

The Ohio State University

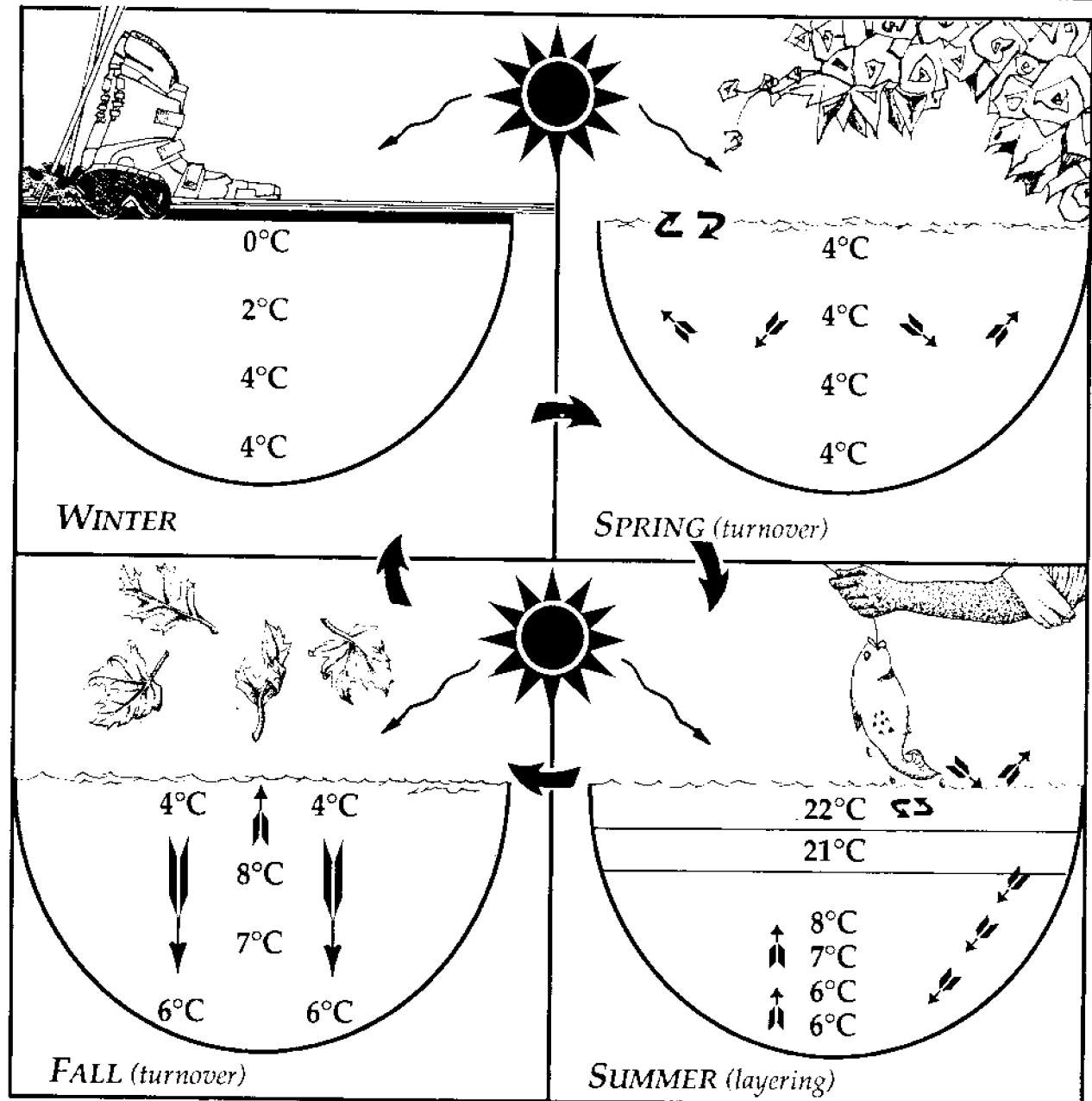

---

This instructional activity was prepared by project E/AID-2, OSURF Account 722670. Ohio Sea Grant College Program is partially supported through grant NA90AA-D-SG496 from the National Sea Grant College Program of the National Oceanic and Atmospheric Administration (NOAA), U.S. Department of Commerce. Support is provided by the Ohio Board of Regents, The Ohio State University, other participating universities, and industries. Funding support was also provided by The Ohio State University's School of Natural Resources and College of Education. Any opinions, findings, conclusions, or recommendations expressed herein are those of the authors, and do not necessarily reflect the views of NOAA or the University.

---

Activity A was adapted from:

Vallentyne, J. R. 1967. A simplified model of a lake for instructional use. *Journal of Fisheries Research Board of Canada*. 24:2473-9, and  
Foley, Arlene F. 1984. "Summer Stratification and Fall Overtum—In a Jar," *Journal of College Science Teaching*, Sept. - Oct., 1984.

Ohio Sea Grant Education  
The Ohio State University  
059 Ramseyer Hall  
29 West Woodruff Avenue  
Columbus, OH 43210  
614/292-1078

Ohio Sea Grant College Program  
The Ohio State University  
1314 Kinnear Road  
Columbus, OH 43212-1194  
614/292-8949

Rosanne W. Fortner, *Education Program Director*  
Victor J. Mayer, *Research Coordinator*  
Lorien Marshall, *Initial Layout Editor*  
Suzanne Abbati, *Final Layout Designer and Illustrator*  
Maran Brainard, *Production Coordinator*

---

Copyright © 1991 by The Ohio State University Research Foundation.

Permission is hereby granted to educators to reproduce the material from the student workbook (only) for educational purposes. The U.S. Government is authorized to produce and distribute reprints for governmental purposes notwithstanding any copyright notation that may appear hereon.



**Introduction:**

Have you ever been swimming in the ocean or a lake and stepped into a deep area where the water was much colder? Why does colder water stay near the bottom of a lake? Every year, deep lakes in the *temperate* zones of the world go through water temperature changes as the seasons change. In the Great Lakes, the water may go from an icy winter condition to temperatures as high as 24°C (75°F) or more. What is occurring in the lake when this happens, and how are the plants and animals in the lake affected?

**Objectives:**

When you have completed this investigation you should be able to:

1. describe how water temperature affects water density;
2. explain how changes in water temperature and density cause stratification of lake waters;
3. describe how stratification of lake waters influences water quality; and
4. explain how phosphorus affects oxygen levels in lakes.

**Aquarium Setup**

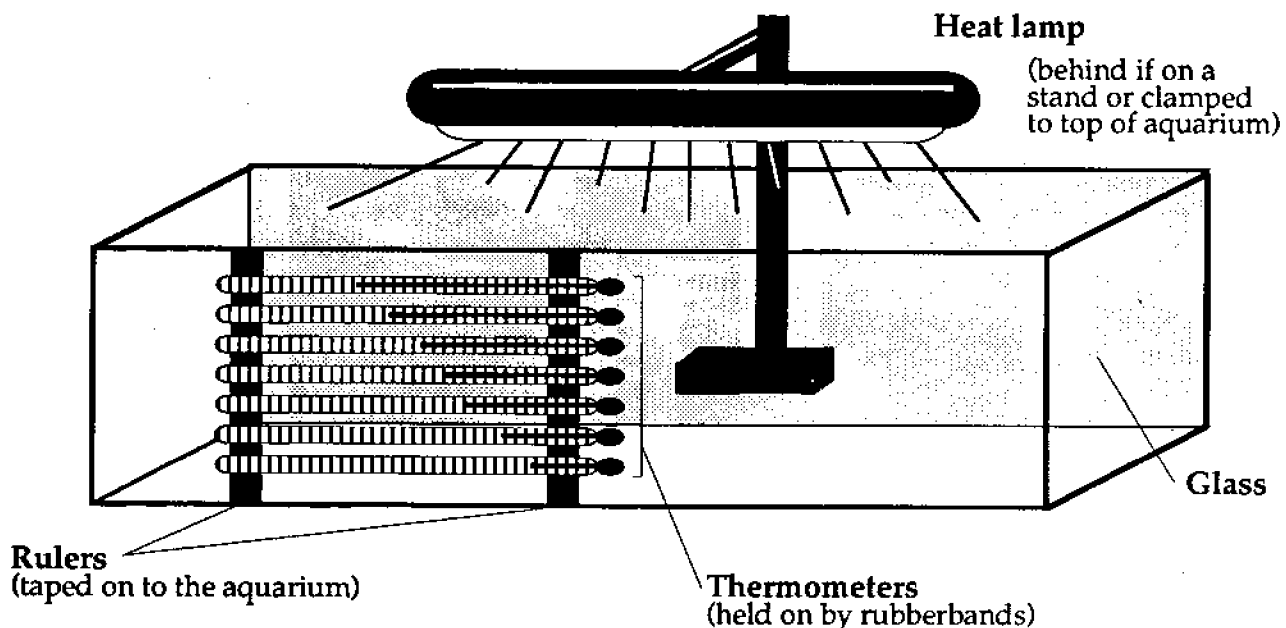

## Activity A: How do the Great Lakes change through the seasons?

### Materials:

An aquarium containing cold tap water, sieve or aquarium net, ice, heat lamp, seven thermometers, rubber bands, two plastic rulers, masking tape, small fan, food coloring, 300 ml flask, 300 ml beaker, colored ice (frozen with food coloring added). **Safety glasses must be worn at all times during this activity.**

### Procedure:

- A. Add enough ice, stirring occasionally, to the aquarium to lower the temperature of the water to 4°C. You should still have a shallow layer of ice on the surface where the temperature will be 0°C. Allow the water to come to rest. In the first column of the temperature data chart on your worksheet, record the temperatures of the seven thermometers.
- B. Remove the rest of the ice with a sieve or aquarium net as gently as possible. Turn on the heat lamp. **Be very careful not to splash any water on the heat lamp or it will explode.** Record this time as the beginning of the experiment.
- C. After 5 minutes, record the temperatures of each of the seven thermometers in the second column of your data chart.
- D. As you wait for the 5 minutes to pass, graph depth in cm versus temperature in °C on graph #1 using the data from column #1. What time of year do these temperatures represent? Label the graph with the time of year.
- E. At the 12 minute mark, record the temperatures on the seven thermometers in the third column of your data chart. Record the water temperatures again at the 30 minute and 45 minute marks in the fourth and fifth columns of your data chart.
- F. While you wait, pour 250 ml of ice water into a 300 ml flask. Weigh the flask.
  1. What is the temperature and weight of this water?

G. Empty the flask and refill it with 250 ml of very hot tap water. Weigh the flask with the hot water and record its weight.

2. What is the temperature and weight of this water?
3. Which temperature of water weighs more?

H. Pour the hot water into a beaker or glass jar. Gently add a few colored ice cubes to the hot water.

4. What happens to the colored water from the ice as the ice melts? Why?

**Spring turnover** occurs when water temperatures at the surface are equal to those at lower depths and water from all depths mixes. The top layers of water may then start to warm slightly.

- I. Which column of temperature data best represents spring turnover in your model lake? Use the data from this column to graph depth in cm versus temperature in °C on graph #2. Label this graph "spring turnover."

As summer approaches, the lake continues to warm.

5. Why do surface temperatures increase during the summer while water temperatures at lower depths remain cold?

During the summer, the lake becomes stratified into three layers of water—the warm upper layer or **epilimnion** (epi = upon or above), the cold bottom layer or **hypolimnion** (hypo = lower or below), and the middle layer of rapid temperature change known as the **metalimnion** (meta = middle).

- J. Which temperature data column best represents the stratified summer lake? Use the data from this column to graph depth in cm versus temperature in °C on graph #3. What season should you label this graph?

6. What is the temperature in the epilimnion? In the hypolimnion? How much tempera-

ture difference is there between these two layers?

When temperature layers form in the lake in the summer the warm surface water (epilimnion) is separated from the cold bottom water (hypolimnion) by the metalimnion. Temperature is not the only factor that is different among the layers. Oxygen dissolves better in cold water than in warm water, but it is getting used up by living things all the time. Wind at the surface of the lake creates waves and stirs up the water, adding oxygen to it in the same way a bubbler works in a fish tank. The metalimnion acts as a barrier. It keeps oxygen in the surface waters from reaching the colder waters of the hypolimnion. Gradually, the oxygen in the hypolimnion can get used up.

7. What happens to the animals living at the bottom of the lake when there is no oxygen?

As autumn begins, the surface waters of the lake begin to cool.

- K. Turn off the heat lamp. Turn on the fan and use it to create a strong wind by blowing on the water from one direction. Keep blowing until all the water in the lake is completely mixed.

Record the water temperatures in the sixth column of your data chart.

8. Why do surface waters of the lake cool off during the fall?

Fall turnover occurs when all the lake water has cooled and has been completely mixed by water movements and wind.

9. How might fall turnover be good for animals living at the bottom of the lake?

10. What seasonal change in lake temperatures has happened in the fall? Are there any temperature layers in the lake once the water has mixed?

- L. Carefully add ice to the surface water to create an ice layer. Try not to mix or disturb the water. Record the water temperatures in the last column of your data chart.

11. What time of year is represented by these temperature data in the last column?

- M. Use the data from the last column to graph depth in cm versus temperature in °C on graph #4. What should this graph be labeled?

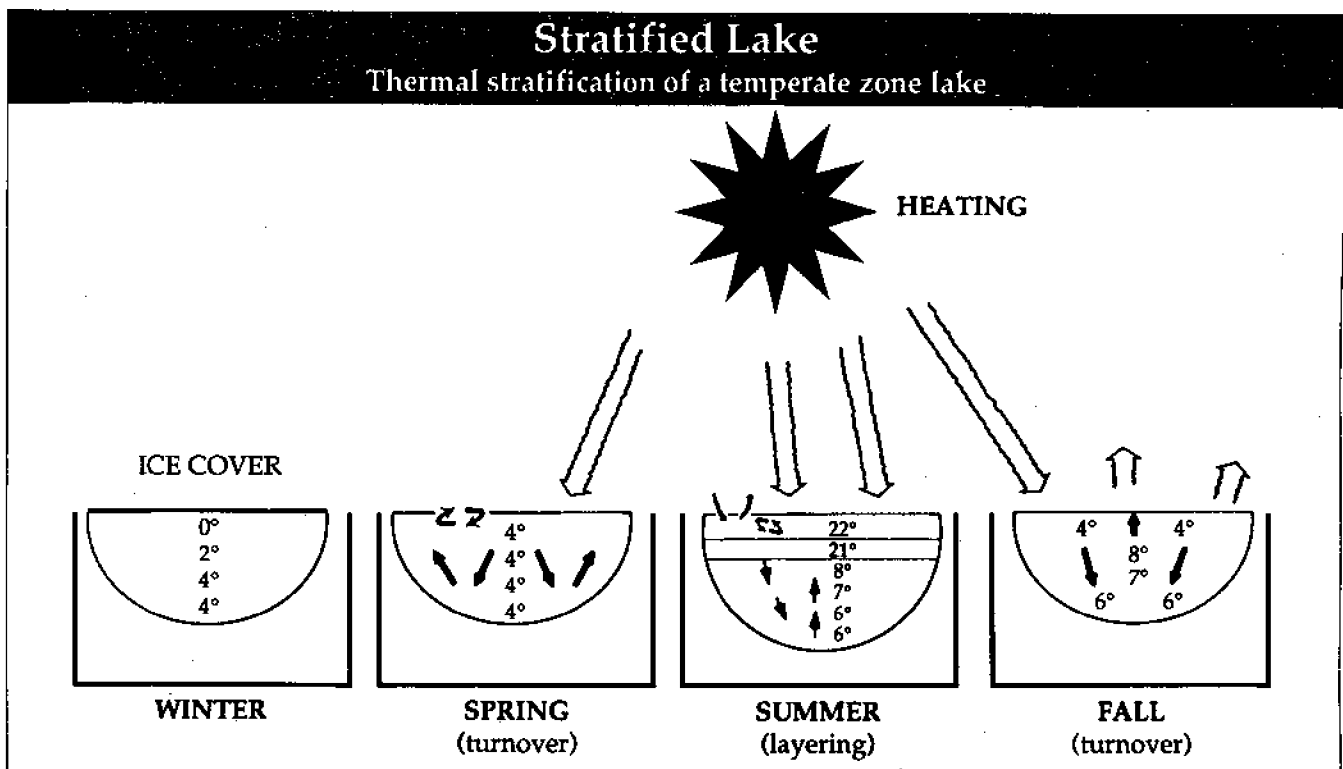

## Activity B: How does stratification affect water quality?

Some of Lake Erie's water quality problems have been related to the layering of the lake's waters, which occurs in the summer months. During the summer, the warm surface layer of water does not mix with the colder bottom layer of water. If a lot of algae has grown in the lake, decay of the dead algae on the lake bottom may use up all of the oxygen in the cold bottom water layer. When there is no oxygen in the bottom waters, the water is said to be anoxic. Fish and other animals cannot live in these anoxic waters. In the fall, the surface water cools and mixes with the bottom water, resupplying the bottom water with oxygen needed for life.

### Materials:

Worksheet and diagrams of anoxic areas in Lake Erie, ruler, string.

### Procedure:

A. Look at the anoxia diagrams of Lake Erie on your worksheet. The shaded area on each diagram shows the part of the lake bottom that was anoxic that year. These parts of the lake contained no oxygen in the hypolimnion.

1. In which year do you think the lake had the largest anoxic area? In which year does the

lake seem to have had the smallest anoxic area?

B. On an enlarged diagram from your teacher use the string and ruler method to measure the perimeter of the anoxic part of the lake in 1930. Stretch the string all the way around the perimeter (outer edge) of the shaded anoxic part. Then stretch the string along the ruler to measure its length in cm. The length of the string is equal to the perimeter of the anoxic part of the lake. You may want to tape the string in place at your starting point or mark your starting point with your pencil.

2. What was the perimeter of the anoxic section in 1930?

C. Repeat step 2 for the enlarged diagrams of the lake in 1964, 1973, 1976, and 1982. Enter the perimeter of the anoxic part of the lake for each year in the chart on your worksheet.

D. Using the steps for finding the area of a circle from its circumference, find the area of the anoxic section of the lake from its perimeter. The formula you should use is  $A=C^2/4\pi$  ( $\pi=3.14$ ).

## Three Basins of Lake Erie

(Adapted from Department of the Interior, "Lake Erie Report," Washington, D.C., 1968)

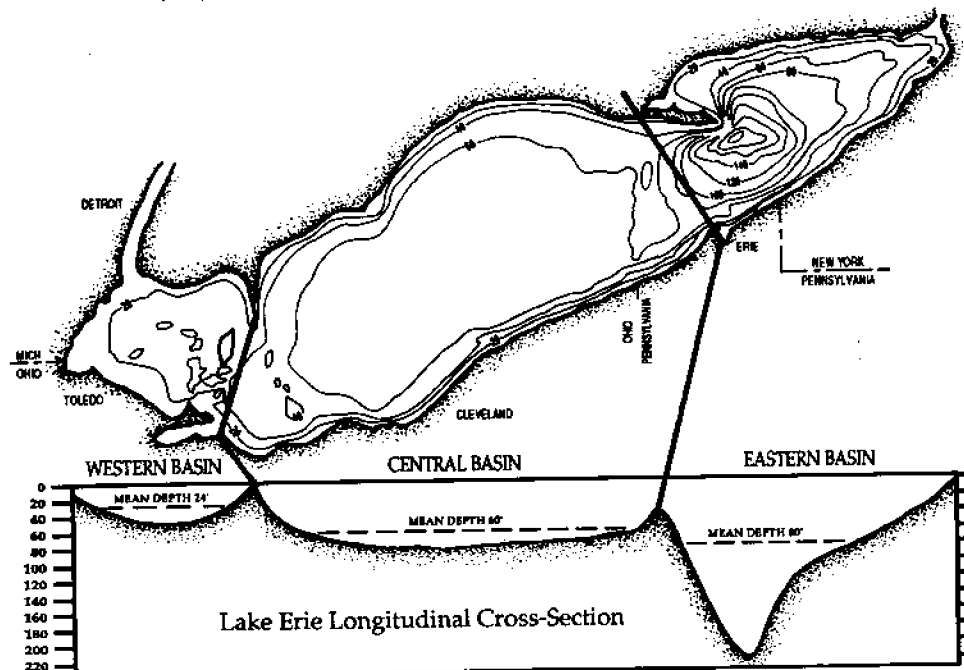

Although the anoxic section is not a perfect circle, we will use this method to estimate the area of the anoxic part of the lake from the perimeter you measured. Enter the area of the anoxic part of the lake for each year in the chart on your sheet.

- In which year did the lake have the largest anoxic area? In which year did it have the smallest anoxic area? How do these results compare to your earlier predictions?

E. Look at the map of Lake Erie divided into its three geographic basins: the Eastern, Central, and Western basins. Match the basins on this map with your map of the lake showing anoxic areas. (See previous page.)

- In which basin of the lake are the anoxic areas found?
- Looking at the map of Lake Erie divided into basins, what is the average depth in each of the three basins?

Usually only large lakes that are deeper than 40 feet or 12 meters stratify into temperature layers during the summer.

- Which of the three basins in Lake Erie will stratify in the summer?
- Does the Western Basin stratify during the summer? Why or why not? Will it become anoxic?
- Is the Central Basin deeper or shallower than the Eastern Basin? Which of the two

basins will have warmer bottom waters? Which of the two basins will have less oxygen in its bottom waters at the beginning of the summer? Which of the two basins is more likely to become anoxic?

Although the Eastern Basin stratifies during the summer, it does not become anoxic. This is because it is so deep. Deep waters are cold, while shallow waters are warm. Cold water can hold much more oxygen than warm water can.

The supply of oxygen in the cold waters of the Eastern Basin at the beginning of the summer is high. Oxygen at the bottom of the lake is used throughout the summer by animals living there and in the decay of dead algae. Stratification of the lake's waters prevents more oxygen from reaching the bottom water. Even so, the oxygen supply in the Eastern Basin does not get used up during the summer, because the supply was very high at the beginning of the summer, and because the hypolimnion is much thicker in the Eastern Basin than it is in the Central Basin.

- What might happen to fish and other animals living in the Central Basin when it becomes anoxic?

The farm fertilizers and the laundry detergents we use both contain a chemical called phosphorus. When fertilizers from farms or sewage containing detergents flow into a lake, phosphorus enters the lake as well. Phosphorus is a nutrient needed by all plants, including algae, to grow. When a large amount of phosphorus enters a lake, it may cause

## Cultural Eutrophication (Aging of Lakes)

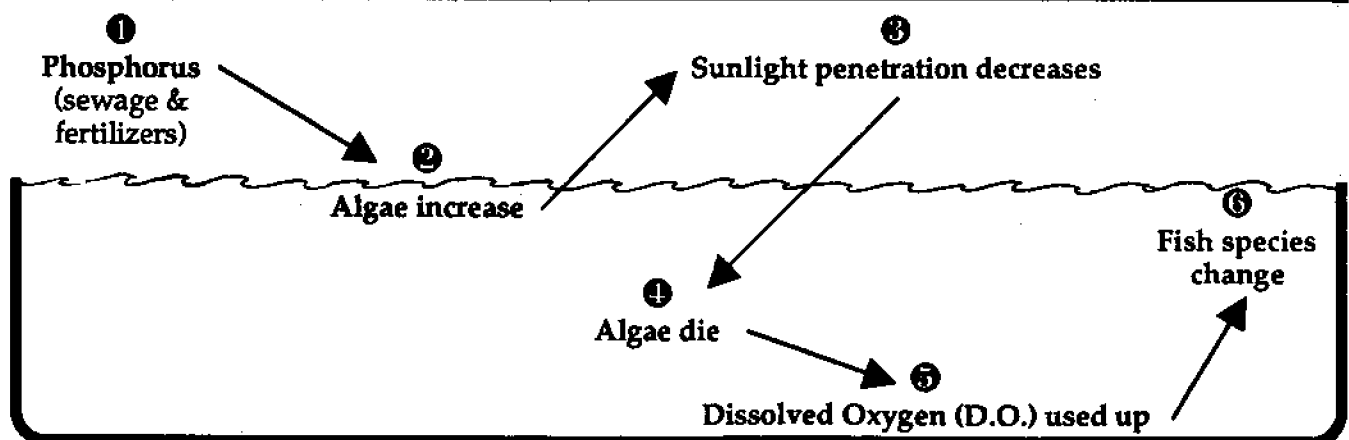

algae to grow very rapidly. The result may be too much algae. The algae may use up the dissolved oxygen (D.O.) in the water, both through their own growth and as they decay.

10. What happens to the lake when growth and decay of algae uses up all the oxygen?

People started putting phosphorus into detergents in the late 1950s. Before that, phosphorus was not used in detergents.

11. How would you now explain the large anoxic areas that occurred in Lake Erie during the 1970s? How can you explain the smaller anoxic areas that occurred in 1930 and 1964?

In 1978, laws were passed by many states in the Great Lakes Basin to limit the amount of phosphorus that could be used in detergents.

12. Why do you think laws banning phosphorus in detergents were passed?

The amount of phosphorus entering Lake Erie has been reduced nearly 60 percent in the past twenty years.

13. How would you now explain why the size of anoxic areas in the lake seems to have decreased since 1976?

In January of 1990, the State of Ohio joined other Great Lakes states that have reduced phosphorus in detergents.

14. Predict what will happen to the anoxic area of Lake Erie in the 1990s if phosphorus continues to be reduced in the lake.

---

## Review Questions

---

1. How does water temperature affect water density?
2. When water is stratified in a lake, where is the colder water found? Why?
3. What are the names given to the three layers of water that form when a lake is stratified?
4. How does stratification affect the amount of oxygen found in the bottom of the lake?
5. Why does the Western Basin of Lake Erie not become anoxic during the summer?
6. What are the human-produced sources of phosphorus nutrients entering the lakes?
7. How does phosphorus contribute to anoxia in Lake Erie?
8. Why have Great Lakes states passed laws limiting the amount of phosphorus that can be used in detergents?

# Lake Layers: Stratification (EP-028S)

## Worksheet

NAME \_\_\_\_\_

### Activity A: How do the Great Lakes change through the seasons?

1. What is the temperature of the ice water in the flask? \_\_\_\_\_  
What is the flask's weight with cold water? \_\_\_\_\_
2. What is the temperature of the hot tap water in the flask? \_\_\_\_\_  
What is the flask's weight with hot tap water? \_\_\_\_\_
3. Which temperature of water is heavier? (compare the flask weights) \_\_\_\_\_
4. What happens to the colored water from the ice as the ice melts? \_\_\_\_\_  
Why? \_\_\_\_\_
5. Why do surface water temperatures increase during the summer while water temperatures at lower depths remain cold?  
\_\_\_\_\_
6. What is the temperature in the epilimnion of your lake? \_\_\_\_\_  
In the hypolimnion? \_\_\_\_\_  
How much temperature difference is there between these two layers? \_\_\_\_\_
7. What happens to the animals living at the bottom of the lake when there is no oxygen?  
\_\_\_\_\_
8. Why do surface water temperatures of the lake cool during the fall? \_\_\_\_\_  
\_\_\_\_\_
9. How might fall turnover be good for animals living at the bottom of the lake? \_\_\_\_\_  
\_\_\_\_\_
10. What seasonal change in lake temperatures has happened in the fall? \_\_\_\_\_  
Are there any temperature layers in the lake once the water has mixed? \_\_\_\_\_
11. What time of year is represented by the temperature data in the last column? \_\_\_\_\_

# Water Temperature Data Chart °C

Depth  
in cm

Time Columns

	#1	#2	#3	#4	#5	#6	#7
1							
3							
5							
9							
13							
17							
21							



# Water Temperature Graphs

Graph #1  
Season \_\_\_\_\_

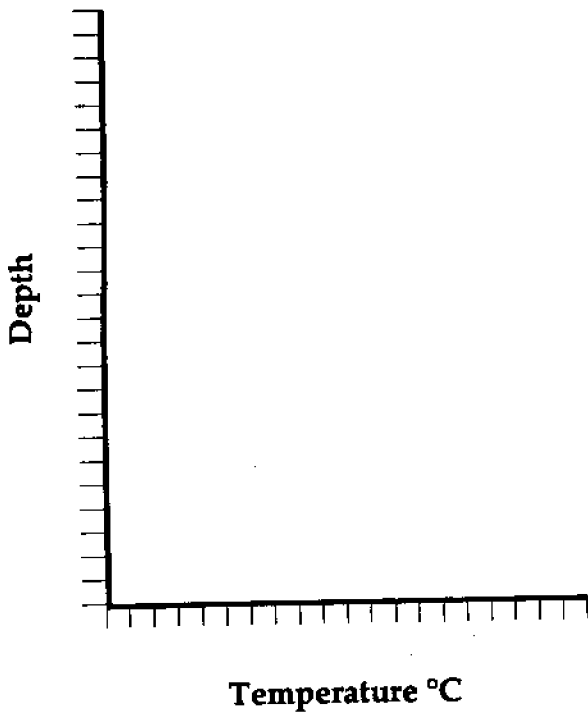

Graph #2  
Season \_\_\_\_\_

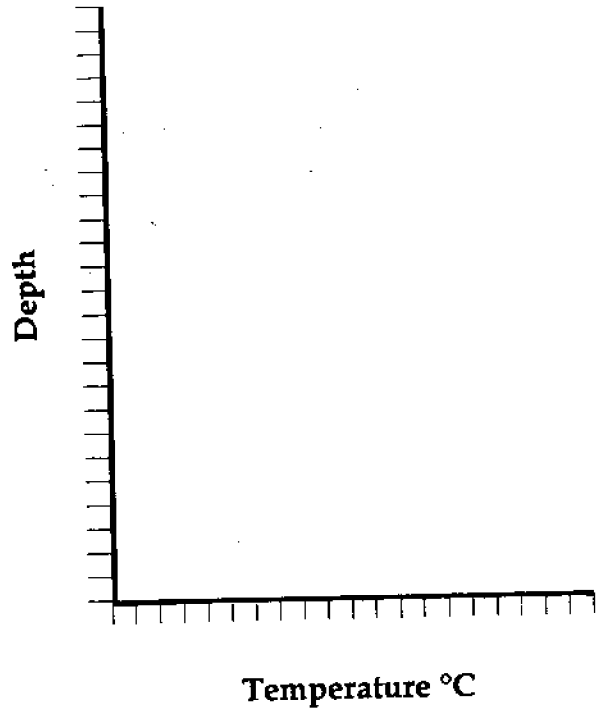

Graph #3  
Season \_\_\_\_\_

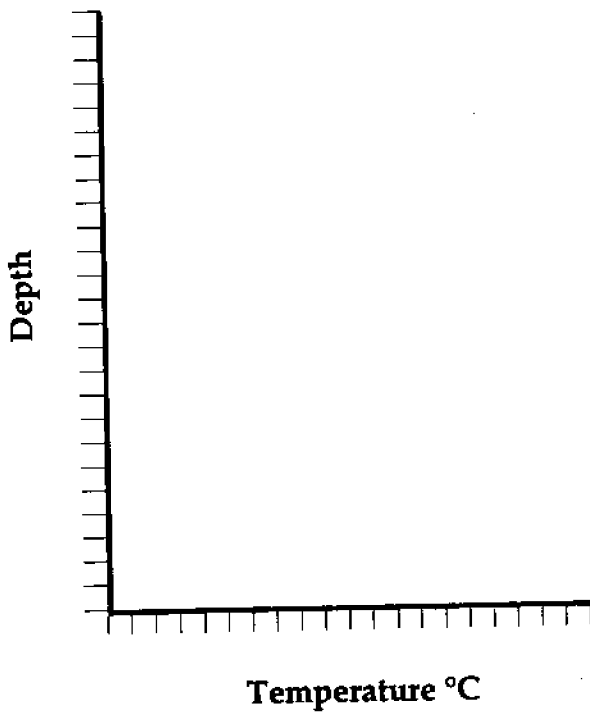

Graph #4  
Season \_\_\_\_\_

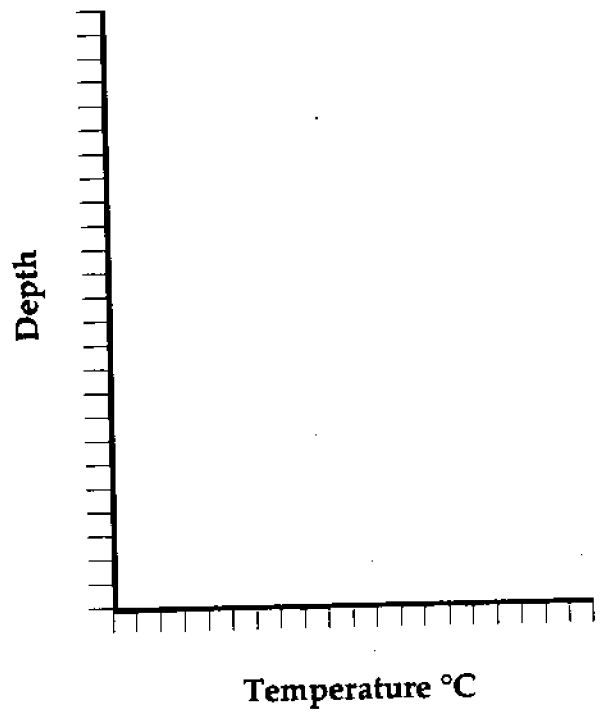

# Lake Layers: Stratification (EP-028S)

## Worksheet

NAME \_\_\_\_\_

### Activity B: How does stratification affect water quality?

1. In which year do you think the lake had the largest anoxic area? \_\_\_\_\_  
 In which year does the lake seem to have had the smallest anoxic area? \_\_\_\_\_

2. What was the perimeter of the anoxic section in 1930?

	YEAR	1930	1964	1973	1976	1982
PERIMETER						
ANOXIC AREA						

3. In which year did the lake have the largest anoxic area? \_\_\_\_\_  
 In which year did it have the smallest anoxic area? \_\_\_\_\_  
 How do these results compare to your earlier predictions? \_\_\_\_\_

4. In which basin of the lake are the anoxic areas found? \_\_\_\_\_

5. What is the average or mean depth in each of the three basins?

Eastern \_\_\_\_\_ Central \_\_\_\_\_ Western \_\_\_\_\_

6. Which of the three basins in Lake Erie will stratify in the summer? \_\_\_\_\_

7. Does the Western Basin stratify? \_\_\_\_\_

Why or why not? \_\_\_\_\_

Will it become anoxic? \_\_\_\_\_

8. Is the Central Basin deeper or shallower than the Eastern Basin? \_\_\_\_\_

Which of the two basins will have warmer bottom waters? \_\_\_\_\_

Which of the two basins will have less oxygen in its bottom waters at the beginning of the summer? \_\_\_\_\_

Which of the two basins will most likely become anoxic? \_\_\_\_\_

9. What might happen to fish and other animals living in the Central Basin when it becomes anoxic?

---

10. What happens to the lake when growth and decay of the algae uses up all the oxygen? \_\_\_\_\_

---

11. How would you now explain the large anoxic areas that occurred in Lake Erie during the 1970s?

---

---

How can you explain the smaller anoxic areas that occurred in 1930 and 1964? \_\_\_\_\_

---

12. Why do you think laws banning phosphorus in detergents were passed? \_\_\_\_\_

---

13. How would you now explain why the size of anoxic areas in the lake seems to have decreased since 1976? \_\_\_\_\_

---

14. Predict what will happen to the anoxic area of Lake Erie in the 1990s if phosphorus continues to be reduced in the lake. \_\_\_\_\_

---

---

## Worksheet for Activity B

---

## Oceanic Education Activities for Great Lakes Schools (OEAGLS)

Results of studies of student knowledge about the oceans and Great Lakes environments indicate a need for greater awareness of those environments, and a greater understanding of the impact they have upon the lives of people. OEAGLS (pronounced "eagles") are designed to take a concept or idea from the existing school curriculum and develop it into an oceanic and Great Lakes context, using teaching approaches and materials appropriate for children in grades five through nine.

OEAGLS materials are designed to be easily integrated into existing curricula. Investigations are characterized by subject matter compatibility with existing curriculum topics, short activities lasting from one to three classes, minimal preparation time, minimal equipment needs, standard page size for easy duplication, student workbook plus teacher guide, suggested extension activities for further information or creative expression, teachability demonstrated by use in middle school classrooms; and content accuracy assured by critical reviewers. Each title consists of a student workbook and a teacher guide and costs \$3.00 for the publication, postage, and handling. If ordering EP-026, add an additional \$4.00 to cover the cost of the computer disk.

- |   |   |
|---|---|
| THE EFFECT OF THE GREAT LAKES ON TEMPERATURE (EP-001) | THE ESTUARY: A SPECIAL PLACE (EP-016)     |
| THE EFFECT OF THE GREAT LAKES ON CLIMATE (EP-002)     | THE GREAT LAKES TRIANGLE (EP-017)         |
| ANCIENT SHORES OF LAKE ERIE (EP-003)                  | KNOWING THE ROPES (EP-018)                |
| HOW TO PROTECT A RIVER (EP-004)                       | GETTING TO KNOW YOUR LOCAL FISH (EP-019)  |
| CHANGING LAKE LEVELS (EP-005)                         | SHIPPING: THE WORLD CONNECTION (EP-020)   |
| EROSION ALONG THE GREAT LAKES (EP-006)                | WE HAVE MET THE ENEMY (EP-021)            |
| COASTAL PROCESSES AND EROSION (EP-007)                | IT'S EVERYONE'S SEA: OR IS IT? (EP-022)   |
| POLLUTION IN LAKE ERIE: AN INTRODUCTION (EP-008)      | PCBs IN FISH: A PROBLEM? (EP-023)         |
| YELLOW PERCH IN LAKE ERIE (EP-009)                    | A GREAT LAKES VACATION (EP-024)           |
| EVIDENCE OF ANCIENT SEAS IN OHIO (EP-010)             | STORM SURGES (EP-025)                     |
| TO HARVEST A WALLEYE (EP-011)                         | RIVER TREK with computer program (EP-026) |
| OIL SPILL! (EP-012)                                   | WAVES (EP-027)                            |
| SHIPPING ON THE GREAT LAKES (EP-013)                  | LAKE LAYERS: STRATIFICATION (EP-028)      |
| GEOGRAPHY OF THE GREAT LAKES (EP-014)                 | NUTRIENTS IN THE GREAT LAKES (EP-029)     |
| OHIO CANALS (EP-015)                                  | EATING LIKE A BIRD (EP-030)               |

### OEAGLets

In the primary grade range we have three activities. All use Lake Erie information applied to all primary subject areas. Each title costs \$5.00 for the publication, postage, and handling.

- LAKE ERIE—TAKE A BOW (EP-031)
- BUILD A FISH TO SCALE (EP-032)
- A DAY IN THE LIFE OF A FISH (EP-033)

### COMPUTER PROGRAMS

All programs run on Apple II computer series.

- EP-24/Disk This program is an optional purchase to accompany OEAGLS A GREAT LAKES VACATION. \$4.00
- EP-74/Disk To accompany OEAGLS EP-011, 019, 021, and 023. \$5.00

### ADDITIONAL EDUCATIONAL MATERIALS

SUPPLEMENTAL CURRICULUM ACTIVITIES TO ACCOMPANY HOLLING C. HOLLING'S

- PADDLE-TO-THE-SEA* (EP-076) \$10.00
- ACTIVITIES FROM MIDDLE SEA (EP-071) \$2.50
- WATERWORKS (EP-072) \$2.50
- THE OHIO SEA GRANT EDUCATION PROGRAM: DEVELOPMENT, IMPLEMENTATION, EVALUATION (EP-075) \$8.00
- MARINE EDUCATION BIBLIOGRAPHY \$2.00

### OTHER PUBLICATIONS AVAILABLE

- TWINE LINE* Sea Grant eight-page bimonthly newsletter. \$4.50 for six issues.
- PUBLICATION BROCHURE Free.
- EDUCATION BROCHURE Free.
- TECHNICAL PUBLICATIONS BROCHURE Free.
- SEA GRANT PROGRAM BROCHURE Free.
- GREAT LAKES PURSUIT *S.E. Pflaumer and R.W. Fortner*. A game played like *Trivial Pursuit*® but the questions challenge players to learn about the Great Lakes. \$24.00 (Reduced price available for educators.)
- TOO MUCH MUSSEL 1991. This 5 1/2 minute video (VHS format) provides an overview of the zebra mussel impact to Lake Erie. \$15.00
- GLOBAL CHANGE IN THE GREAT LAKES SCENARIOS 1991. Ten scenarios about global change in the Great Lakes. \$6.00



**Ohio Sea Grant College Program**

The Ohio State University  
1314 Kinnear Road  
Columbus, OH 43212-1194  
Tel. 614/292-8949  
Fax 614/292-4364

(Send all publication requests to this address)

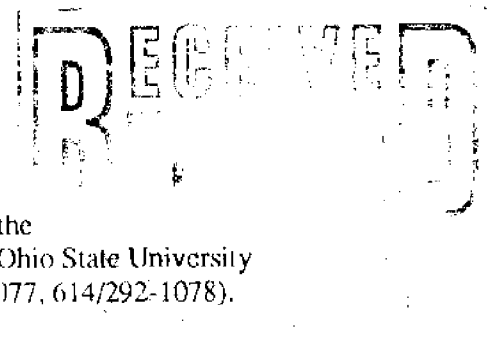

For information about the education program, contact the  
Ohio Sea Grant Education Coordinator, *Dr. Rosanne W. Fortner*, at The Ohio State University  
(59 Ramseyer Hall, 29 W. Woodruff Avenue, Columbus, OH 43210-1077, 614/292-1078).

*Dr. Jeffrey M. Reutter*, Ohio Sea Grant Director