



# Supplemental Curriculum Activities

for use with

Holling Clancy Holling's

LOAN COPY ONLY

CIRCULATING COPY  
Sea Grant Depository

# Paddle-to-the-Sea

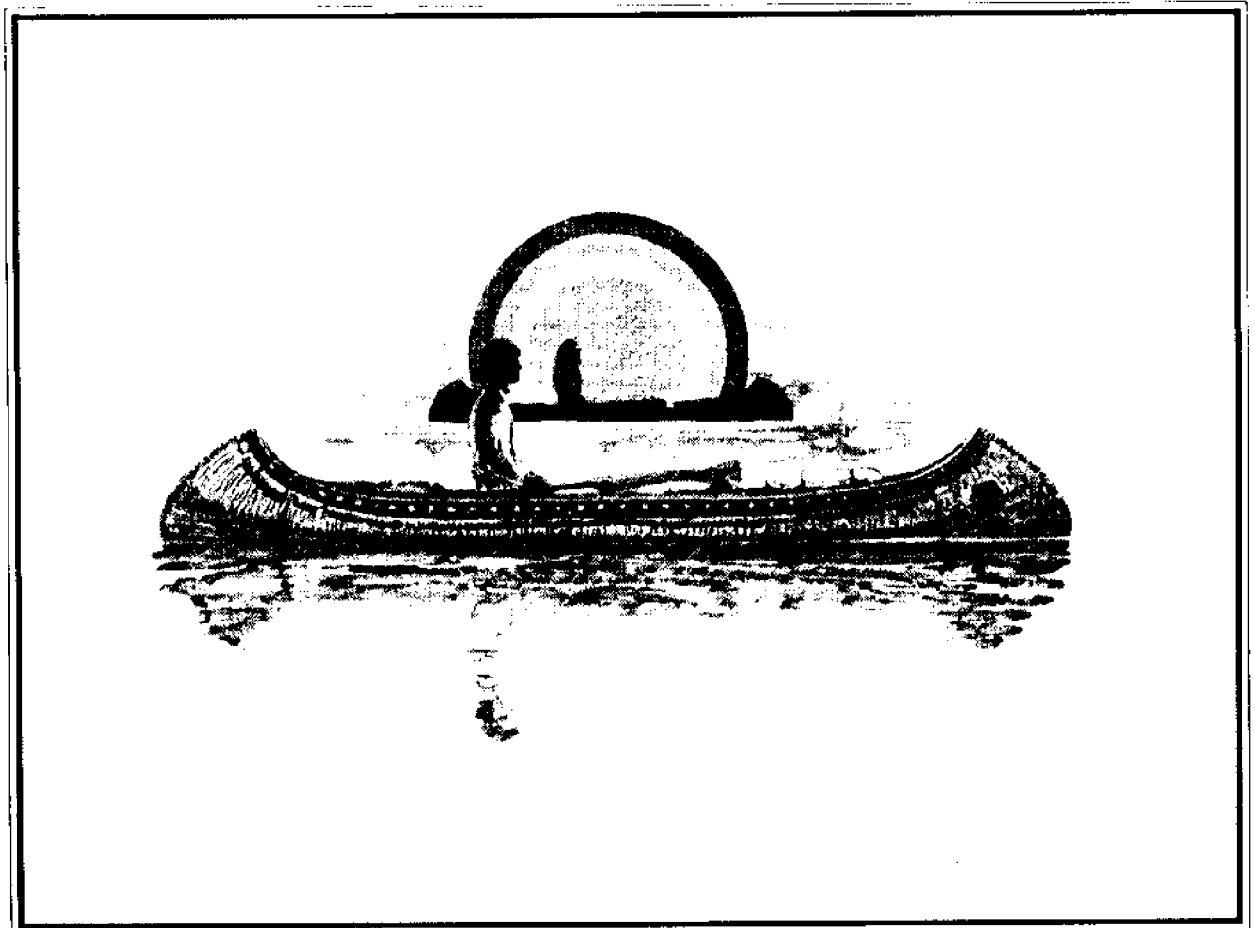

by

*Marcia L. Seager, The Ohio State University*  
*Rosanne W. Fortner, The Ohio State University*  
*Timothy A. Taylor, Muskingum County Schools*

This publication is being made available by the  
Ohio Sea Grant College Program at  
The Ohio State University as OHSU-EP-076.  
Additional copies are available for \$10.00 from  
Ohio Sea Grant, The Ohio State University,  
1314 Kinnear Road,  
Columbus, OH 43212-1194.  
Make checks payable to The Ohio State University.

A cooperative publication of the Ohio Sea Grant Education Program,  
The Ohio State University, and the International Joint Commission

© 1988 by The Ohio State University. Reprinted 1991.

Production assistance was provided by the  
Ohio Sea Grant Communications Program including  
Suzanne Abbati (design),  
Pamela Brown (copy editor), and  
Maran Brainard (coordination).

Permission is hereby granted to educators to reproduce worksheet  
portions of this material for educational purposes.  
The U.S. Government is authorized to produce and distribute  
reprints for governmental purposes notwithstanding any  
copyright notation that may appear hereon.

Cover illustration from *Paddle-to-the-Sea* by Holling C. Holling,  
© copyright 1941 and renewed 1969 by Holling C. Holling.  
Reprinted by permission of Houghton Mifflin Company.

LOAN COPY ONLY

Supplemental Curriculum Activities  
for use with  
Holling Clancy Holling's

# Paddle-to-the-Sea

by

*Marcia L. Seager*, The Ohio State University  
*Rosanne W. Fortner*, The Ohio State University  
*Timothy A. Taylor*, Muskingum County Schools

and

a special thanks to

*John R. Vallentyne*, International Joint Commission,  
for his cooperation and input

\$10.00

# Table of Contents

	Page		Page
<i>Introduction</i>	<i>i</i>	Effects of Poison chart	75
<i>Preface</i>	<i>iii</i>	Travel Math	76
<i>Cross-reference of activities by chapter</i>	<i>iv</i>	Scale and Perimeter worksheet	77
<i>Summary of activities</i>	<i>vi</i>	Distance, Rate, and Time worksheet	81
<b>Activities</b>		Uses of Iron Ore	83
Great Lakes Geography	1	Iron Ore worksheet	84
Map of the Great Lakes worksheet	2	Something's Fishy	86
Travel-to-the-Sea	4	Fish Anatomy identification	87
Carving a Paddle Person	6	Fish Anatomy descriptions	88
Sample pattern	8	Fish Puzzle pieces	89
In One Lake and Out Another	9	Fish Anatomy worksheet	93
Water Rates worksheet	12	Going Fishing	95
How Big is a Crowd?	14	Thunderbirds and Sunsets	96
Information tables	15	Weather Folklore background sheet	97
Rivers in the Air	19	Thunderbird outline	98
Tour by Mail	21	Oral History	99
Time Line	23	Breeches Buoy Rescue	101
What Do You "See" in the Great Lakes?	25	Building a Breeches Buoy diagram	102
Lake Erie outline	26	How Locks Work	103
Lake Michigan outline	27	How Navigational Locks Operate diagram	104
Lake Huron outline	28	Building Your Own Lock diagram	105
Lake Superior outline	29	Clean Campaign	107
Lake Ontario outline	30	Forest Fires—Good and Bad	109
Taken by Surprise	31	Building a "Birchbark" Canoe	110
Animal Snowshoes	32	Canoe pattern	112
Animal Snowshoes worksheet	34	Harbor Guides	113
Tracking a Good Story	36	Over the Falls!	114
Animal Print Identification worksheet	38	Great Lakes Bulk Carriers	115
Animal track diagrams	40	Great Lakes Cargo worksheet	117
Sample track picture story	44	Great Lakes Bulk Carrier diagram	121
Pond Diorama	45	Great Lakes Bulk Carrier puzzle	122
Beaver's Point of View	47	Parlez-vous français?	124
Forest Careers	48	French Words	125
Forest Careers worksheet	50	French Word puzzle	126
Uses of Trees	52	Voyageurs' song	128
Logs to Lumber	54	Life in an Estuary	129
Sawmill Terms crossword puzzle	55	About Estuaries background sheet	130
How Waves Move	57	Life in an Estuary worksheet	132
Parts of a Wave diagram	58	Sharing Ecosystem Resources	134
How Waves Move worksheet	59	Categories of Nations	136
Passport to Adventure	61	Role-playing cards	137
Passport application	63	The Challenge of Chief Seattle	146
Passport booklet patterns	64	The Sea at Last!	149
Passport Language crossword puzzle	66	Paddle Makes Headlines	150
Energy Flow and Food Webs	68	A Dream Comes True	151
Energy Flow background sheet	69		
Energy Flow worksheet	71	<b>Appendix</b>	
Food Chain Tag	73	Great Lakes Education Resources	152

---

## Using Paddle-to-the-Sea

---

Holling Clancy Holling's talents are at their best in the classic *Paddle-to-the-Sea*. The story can be read, understood, and enjoyed on at least three levels of student ability, thanks to Holling's artistry with words and pictures. On the simplest level, the color illustrations alone can be used to tell the story. Each chapter contains a full-page picture that perfectly shows what the chapter is about. On a second level, the words of the chapter reveal the ideas, develop the characters and settings, and explain what the pictures are showing. For detailed study, the black-and-white drawings in the margins of the text offer an expanded view of main points in the story and teach new material to enhance understanding. From these drawings we learn how locks work, see interim maps showing where Paddle is at each point, and compare the before and after of a forest fire. Enjoy Paddle on the level most appropriate for your class.

You may also wish to show the 1967 film, *Paddle-to-the-Sea*, which is distributed by the National Film Board of Canada. The film is 28 minutes long. Students who previewed it with us were attentive throughout.

### Using this Curriculum Guide

These Curriculum Activities have been developed for use in grades 3 through 6. They have been tested among students and teachers in those grades and found to be an interesting supplement to existing curriculum topics, as well as an exciting way to teach those same topics. Choose any or all of the activities presented to reinforce the concepts introduced in the story. The time you will need to complete each activity varies; some activities require planning and preparation in advance. At the beginning of each activity, you will find a statement of objectives that may help you to choose activities appropriate for your class.

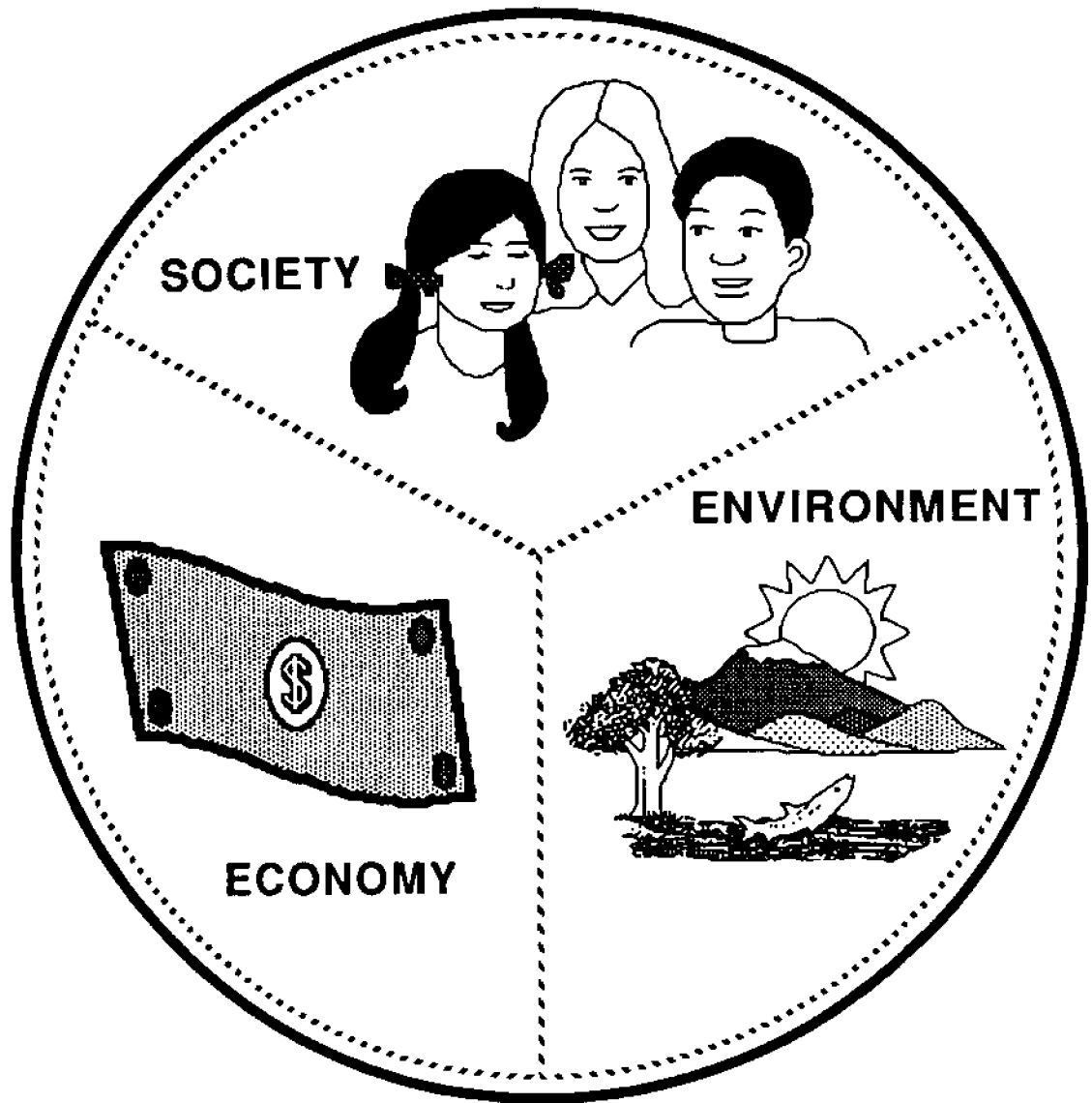

## The Ecosystem Approach

---

# Preface

## The Ecosystem Approach

---

Research by the Ohio Sea Grant Education Program<sup>1</sup> has shown that middle school students in the Great Lakes region do not have a great deal of knowledge about the lakes. In fact, 54% of the fifth graders and 40 percent of the ninth graders tested in Ohio in 1983 could not identify Lake Erie on a map of the Great Lakes. Even fewer could identify the other lakes. Those ninth graders are now voters, each with a vote equal to yours and mine. We cannot be satisfied with the implications of this level of knowledge among our students when it comes to resources as vital as our Great Lakes. Lack of knowledge is a symptom of a larger problem: a lack of holistic thinking about the ecosystem. We are an integral part of this system. What happens to it happens to all citizens of the world.

*Paddle-to-the-Sea*, a classic in children's literature, offers an opportunity to learn about the Great Lakes Basin ecosystem in a meaningful and memorable way. On one level the story teaches about the geography and economy of the region. On a higher level it provides a look at the interactions of animals in the environment, of people with the environment, and of the ecosystem's impact on all who live or even pass through this "long river reaching to the sea." On this level, *Paddle* is an example of the **ecosystem approach**<sup>2</sup>.

To approach something on an ecosystem level is to view it as a connected whole, to see the importance of specific parts, but always in relation to the whole and with us in it. While it is interesting to learn what animal tracks can tell us, or how a beaver's lodge is built, or how iron ore is shipped on the Great Lakes, these should be viewed as environmental information that has been designed to contribute to an understanding of the entire Great Lakes Basin ecosystem. The physical conditions of the region—its geography, its climate, its water quality—define and interact with the environments depicted in *Paddle-to-the-Sea*; in turn all those environments are influenced by people and influence them in return. Together it is an ecosystem.

There is a consensus among organizations and governments in the Great Lakes Basin that the lakes must be managed with an ecosystem approach. This not only requires an understanding of what the individual parts to be managed actually are, but more importantly, an understanding of how those parts interrelate with each other and with the ecosystem as a whole. To teach about the Great Lakes using the Curriculum Activities for *Paddle-to-the-Sea* is to take an ecosystem approach. The authors and promoters of this work hope that teachers will find a place in the curriculum to use most of the activities described here. Individually the activities can teach about the environments *Paddle* visits, but together they convey the important concept that everything is connected. It is our hope that students will carry away from this unit some of the awe and respect that Holling Clancy Holling felt when he wrote about the Great Lakes, as well as a feeling of being a part of this remarkable ecosystem.

*Rosanne W. Fortner*

Rosanne W. Fortner, Associate Professor  
School of Natural Resources, The Ohio State University

<sup>1</sup>Fortner, Rosanne W. and Victor J. Mayer, 1983. Ohio students' knowledge and attitudes about the oceans and Great Lakes. *Ohio Journal of Science* 83(5): 218-224.

<sup>2</sup>Vallentyne, John R. and Alfred M. Beeton, 1988. The ecosystem approach to managing human uses and abuses of natural resources in the Great Lakes Basin. *Environmental Conservation*. 15(1): 58-62.

TITLE	CHAPTER																											
	GEN	1	2	3	4	5	6	7	8	9	10	11	12	13	14	15	16	17	18	19	20	21	22	23	24	25	26	27
Great Lakes Geography	*	*	*																									
Travel-to-the-Sea	*		*	*																								
Carving a Paddle Person	*	*																										
In One Lake and Out Another	*																											
How Big is a Crowd?	*																											
Rivers in the Air	*																											
Tour by Mail	*																											
Time Line	*																											
What Do You "See" in the Great Lakes?	*							*													*							
Taken By Surprise		*																										
Animal Snowshoes			*																									
Tracking a Good Story				*																								
Pond Diorama				*																								
Beaver's Point of View				*																								
Forest Careers					*																							
Uses of Trees					*		*																					
Logs to Lumber					*		*																					
How Waves Move							*		*																			
Passport to Adventure								*																				
Energy Flow and Food Webs									*																			



TITLE	CHAPTER																												
	GEN	1	2	3	4	5	6	7	8	9	10	11	12	13	14	15	16	17	18	19	20	21	22	23	24	25	26	27	
Food Chain Tag																													
Travel Math											*																		
Uses of Iron Ore											*																		
Something's Fishy											*																		
Going Fishing											*																		
Thunderbirds and Sunsets												*												*					
Oral History												*																	
Breeches Buoy Rescue												*	*																
How Locks Work																	*	*											
Clean Campaign																		*											
Forest Fires—Good and Bad																			*										
Building a "Birchbark" Canoe																				*									
Harbor Guides																					*								
Over the Falls!																					*								
Great Lakes Bulk Carriers																				*									
Parlez-vous français?																							*						
Life in an Estuary																										*			
Sharing Ecosystem Resources																									*	*			
The Sea at Last!																									*	*			
Paddle Makes Headlines																										*	*		
A Dream Comes True																											*	*	

---

# Summary of Activities

---

## **Great Lakes Geography**

Identify the shapes of the Great Lakes and surrounding states and provinces on a map.

## **Travel-to-the-Sea**

Learn how local streams or rivers merge with other waterways to reach the ocean.

## **Carving a Paddle Person**

Learn how to use scale patterns in making carved models and how to carve safely.

## **In One Lake and Out Another**

Study the hydrologic cycle. Compare the filling times of the Great Lakes and the time it takes for pollutants to flow through.

## **How Big is a Crowd?**

Compare the number of people that live around each lake and demonstrate how people must share and care for resources.

## **Rivers in the Air**

Learn how air currents act like rivers to carry floating objects.

## **Tour by Mail**

Learn how to write a business letter correctly and receive information from various Great Lakes cities.

## **Time Line**

Illustrate the major events that occurred during each season of Paddle's voyage and find out how long it took Paddle to reach the sea.

## **What Do You "See" in the Great Lakes**

Use the shape of each lake to suggest the outline of familiar figures or shapes.

## **Taken by Surprise**

Write a story about being taken by surprise while trying to finish a project.

## **Animal Snowshoes**

Learn how feet can act like snowshoes and calculate foot area and pressure for different animals.

## **Tracking a Good Story**

Identify pictures of animal tracks and make a track picture "story."

## **Pond Diorama**

Make a diorama illustrating the beaver pond.

## **Beaver's Point of View**

Write a story about the pond from the old beaver's point of view.

---

# Summary of Activities

---

## **Forest Careers**

Find out about job responsibilities in many types of forest careers. Take a field trip (optional)

## **Uses of Trees**

Learn how trees are used and what products are made from them.

## **Logs to Lumber**

Find out how a tree becomes lumber. Complete the puzzle using vocabulary words from the story.

## **How Waves Move**

Learn the parts of a wave and do an experiment to show how objects move in waves.

## **Passport to Adventure**

Learn passport terminology, make your own "passports," and play a travel game.

## **Energy Flow and Food Webs**

Learn how animals and plants interact in a food web using a pond food web as an example.

## **Food Chain Tag**

Play a game illustrating the effects of toxins on animals in a simple food chain.

## **Travel Math**

Work with perimeter and distance-rate-time problems.

## **Uses of Iron Ore**

Learn where iron ore is found, how it is processed, and what products are made from it.

## **Something's Fishy**

Learn basic fish anatomy, play a game to identify parts of a fish, and complete a fish puzzle.

## **Going Fishing**

Create your own fish with paper and paint.

## **Thunderbirds and Sunsets**

Explore folktales about weather and write your own story explaining a weather event.

## **Oral History**

Interview an older person about how things have changed over time.

## **Breeches Buoy Rescue**

Use small pulleys and string to build a working model of a breeches buoy.

## **How Locks Work**

Use milk cartons to build a working model of a system of locks.

---

## Summary of Activities

---

### **Clean Campaign**

Organize a litter cleanup in your community and see how much recyclable material you can collect.

### **Forest Fires—Good and Bad**

Learn how fires can benefit as well as harm the environment.

### **Building a “Birchbark” Canoe**

Use oaktag and yarn to make a model of a birchbark canoe.

### **Harbor Guides**

Play a game to illustrate how ships move through busy harbors.

### **Over the Falls**

Write a story about how Paddle might have felt as he fell over Niagara Falls.

### **Great Lakes Bulk Carriers**

Learn the parts of a Great Lakes bulk carrier and find out what cargoes are moved on the Great Lakes.

### **Parlez-vous français?**

Learn simple French words and phrases and complete a word puzzle. Sing a voyageurs' song.

### **Life in an Estuary**

Learn what an estuary is and why it is an important resource.

### **Sharing Ecosystem Resources**

Use role-playing to simulate a Law of the Sea conference. Compare it with Chief Seattle's view of resource use.

### **The Sea at Last!**

Write about how Paddle might feel now that he has finally reached the sea.

### **Paddle Makes Headlines**

Write and illustrate an article that might have appeared in a French newspaper when Paddle arrived in France.

### **A Dream Comes True**

Write a story about how you might feel if your dreams really came true.

---

# Great Lakes Geography

---

## Introduction

Holling compared the Great Lakes to bowls set on a hillside, water running from one “bowl” to another and on into a river that eventually reached the sea. The states and provinces of two countries surround the Great Lakes and the St. Lawrence River, which connects them to the Atlantic Ocean. These are among the largest lakes in the world, and they are an important resource for all the people living along this “long river reaching to the sea.”

## Objective

When students have completed this activity, they will be able to identify the Great Lakes and the surrounding states and provinces on a map.

## Materials

**Map of the Great Lakes** worksheet (master on page 2), wall map (in pocket of back cover), stiff paper or oaktag, double-stick tape, labelled map of the Great Lakes area.

## Procedure

1. Reproduce the student worksheet, **Map of the Great Lakes**. See how many of the Lakes, states, and provinces students can identify. Use a labelled map of the area as an identification guide when students have named as many of the shapes as possible on their own. (You may want to repeat the worksheet as a post-test after finishing the story.)
2. Put up the wall-sized outline map of the Great Lakes area. You may want to laminate this map for durability. Make tags from stiff paper or oaktag to label the lakes, states and provinces. Have students take turns matching the names to the shapes on the map. Use double-stick tape to attach the tags to the map. As you read *Paddle-to-the-Sea*, you may want to make additional tags to label cities, rivers, or other areas mentioned in the story.
3. Use string or yarn to mark Paddle’s progress as you read each chapter. Compare your map with the author’s in the back of the original book.
4. Vary the drill as you read the story. For example, on one day have students draw labels out of a hat and place them in the correct locations on the wall map. On another day, assign a route to be taken (for example, from Quebec to Gary Indiana) and have students identify lakes, states, and cities along the chosen route. On a third day, take turns guessing the name of a place from each other’s descriptions of its location on the map, size, shape, and so on.

NAME \_\_\_\_\_

## Map of the Great Lakes worksheet

Write the letter or number of each place on the map beside the correct name of the list below.

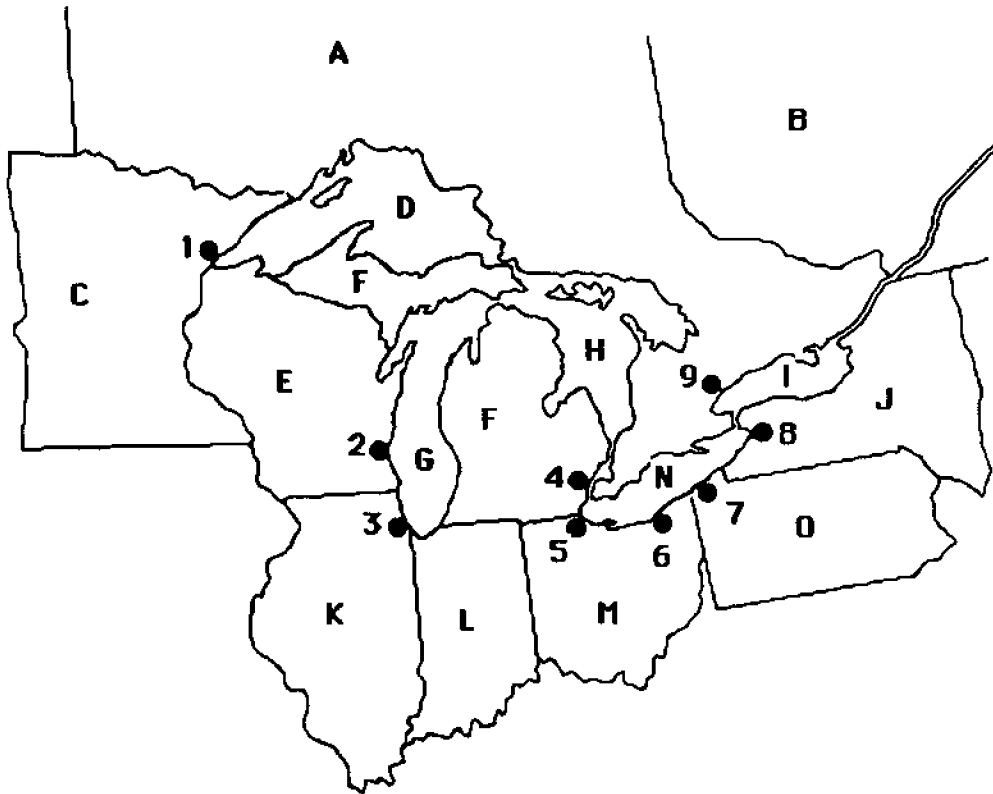

### States and Provinces

- \_\_\_\_\_ Illinois
- \_\_\_\_\_ Indiana
- \_\_\_\_\_ Michigan
- \_\_\_\_\_ Minnesota
- \_\_\_\_\_ New York
- \_\_\_\_\_ Ohio
- \_\_\_\_\_ Ontario
- \_\_\_\_\_ Pennsylvania
- \_\_\_\_\_ Quebec
- \_\_\_\_\_ Wisconsin

### Major Cities

- \_\_\_\_\_ Buffalo
- \_\_\_\_\_ Chicago
- \_\_\_\_\_ Cleveland
- \_\_\_\_\_ Detroit
- \_\_\_\_\_ Duluth
- \_\_\_\_\_ Erie
- \_\_\_\_\_ Milwaukee
- \_\_\_\_\_ Toledo
- \_\_\_\_\_ Toronto

### Great Lakes

- \_\_\_\_\_ Lake Erie
- \_\_\_\_\_ Lake Huron
- \_\_\_\_\_ Lake Michigan
- \_\_\_\_\_ Lake Ontario
- \_\_\_\_\_ Lake Superior

# ANSWER KEY – Map of the Great Lakes worksheet

Write the letter or number of each place on the map beside the correct name of the list below.

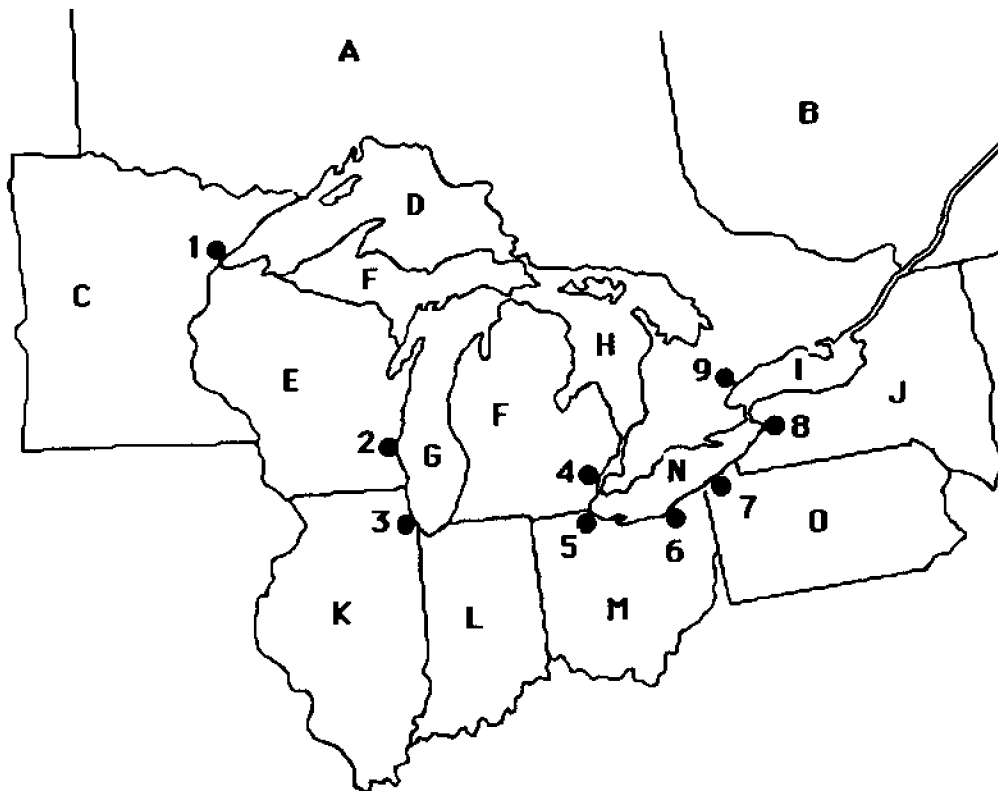

## States and Provinces

- K   Illinois
- L   Indiana
- F   Michigan
- C   Minnesota
- J   New York
- M   Ohio
- A   Ontario
- O   Pennsylvania
- B   Quebec
- E   Wisconsin

## Major Cities

- 8   Buffalo
- 3   Chicago
- 6   Cleveland
- 4   Detroit
- 1   Duluth
- 7   Erie
- 2   Milwaukee
- 5   Toledo
- 9   Toronto

## Great Lakes

- N   Lake Erie
- H   Lake Huron
- G   Lake Michigan
- I   Lake Ontario
- D   Lake Superior

---

# Travel-to-the-Sea

---

## Introduction

The Indian boy knew that his Paddle Person could reach the sea because he knew that the little stream near his home flowed into a river, which in turn flowed into Lake Superior. He knew that Lake Superior was connected to the other Great Lakes and that these lakes emptied into a river that reached the Atlantic Ocean. We can trace the flow of water in any stream as it flows downstream to rivers, lakes, and finally to the sea.

## Objective

When students have completed this activity, they will be able to explain how their local stream or river merges with other waterways to eventually reach the ocean.

## Materials

Map of local waterways (most detailed area road maps show streams, rivers, and lakes), map showing major rivers emptying into the oceans (from an atlas, for example).

## Procedure

1. On the map of local waterways, locate the stream closest to your school or town. Have students trace the route of the stream as it merges with other waterways until it reaches a major river. You will need to know in which direction the water flows to be able to trace its route downstream (in the direction of the flow).
2. Identify the major river connected to your local stream. Find this river on the map of major rivers, and trace its route to the ocean. You may want to draw a diagram of the waterways between your stream and the ocean on the blackboard. If a river forks, there may be more than one possible route to the sea. Trace out all of the possible routes. *(A sample map on the following page traces one route from Columbus, Ohio, to the sea.)*

## Discussion Questions

1. If we put a Paddle Person in our local stream, where would it go?
2. What waterways would carry our Paddle Person toward the ocean?
3. Is there anything along this route that could keep our Paddle Person from eventually reaching the ocean (a dam, for example)?
4. Would it be possible for our Paddle Person to travel by more than one route? If so, where would the different routes carry our Paddle Person?



5. What places would our Paddle Person pass by on the way to the ocean?

6. What ocean would our Paddle Person reach?

### Extension Activity

Carve your own Paddle Person and release it in your local stream. Directions for carving are on page six.

### Sample Map

Arrows show the direction in which water flows

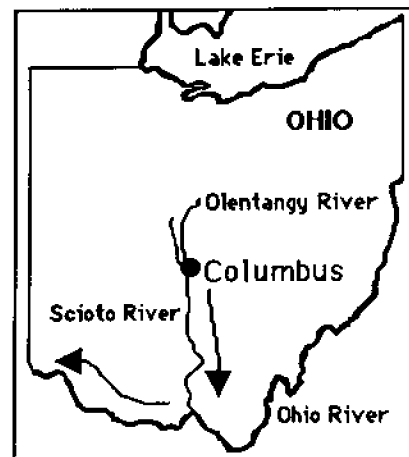

---

# Carving a Paddle Person

---

## Introduction

The Indian boy carved his Paddle Person to look like a real person in a canoe. To make his small model, the Indian boy used a scale pattern to make sure that the proportions in his model were the same as in real life. For example, if a real canoe measured twelve feet long and two feet high, a model of the same canoe might be twelve inches long and two inches high. In this case the scale for the model is one inch to one foot. A larger model might be twenty-four inches long and four inches high. In this case the scale is two inches to one foot. In both cases, though, the proportions of the model canoe remain the same as the proportions of the real one: all are six times longer than they are high.

## Objectives

When students have completed this activity, they will be able to explain how to use scale patterns in making carved models and to list carving safety rules.

## Materials

Graph paper for making patterns, blocks of balsa wood (about 2 X 4 X 8 inches, available at most craft shops), jack knives or sharp paring knives, sandpaper, acrylic paints and small paint brushes (optional).

## Rules for Carving Safely

1. Always carve with the sharp edge of the blade pointing away from you.
2. Make sure there is plenty of space around you so that you don't bump others while carving.
3. Remove wood from the block a little bit at a time; never try to carve off large chunks.
4. A sharp knife cuts wood more easily.
5. Always close a jack knife before carrying it; carry a paring knife with the blade down and the sharp edge back.

## Procedure

1. Read and discuss the carving safety rules. Be sure students understand the importance of following these rules while they are carving.

2. On the graph paper, trace around the side of the block of wood. This will give you the maximum possible size of your model.
3. Draw the outline of a Paddle Person inside the rectangle. There is a sample pattern on the next page, and the illustrations in the book may also be helpful to you. Remember to consider the proportions of your model. You may want to measure one of the illustrations in the book and decide on a scale to keep the same proportions as you draw your outline within the rectangle.
4. Place your graph paper over one side of your block of wood and trace around your outline with a dull pencil, pressing hard. Balsa wood is very soft, and the pencil will push the outline into the wood. Turn your graph paper over, place it over the other side of the block, and press the outline into that side. Make sure that the front of the canoe is at the same end on both sides of the block!

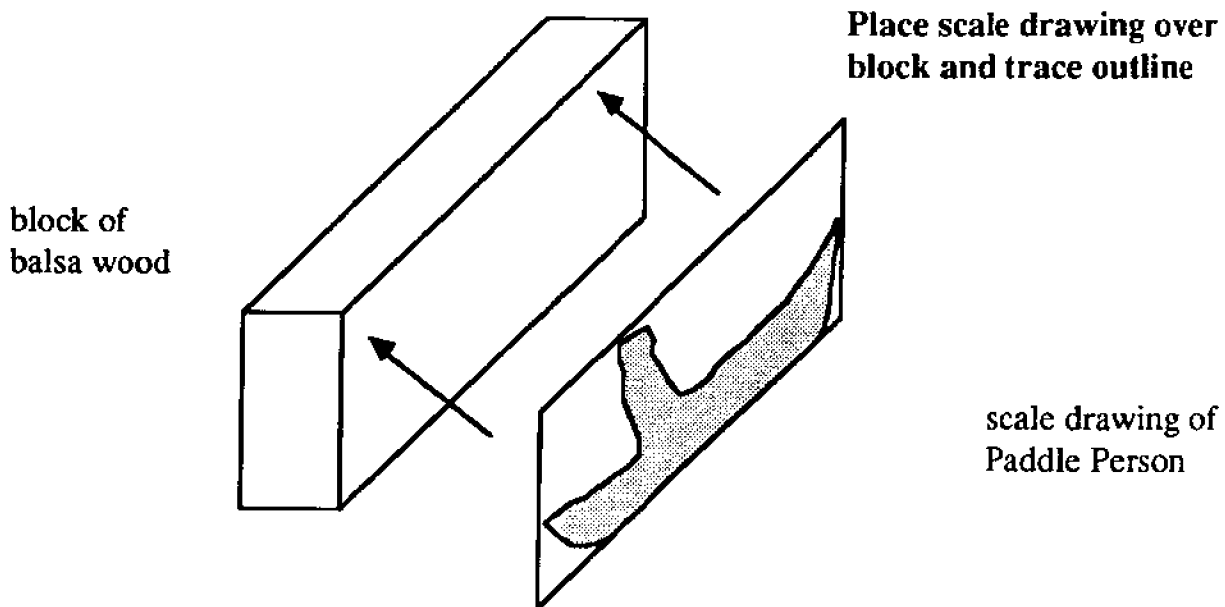

5. Using a sharp knife, slowly carve small pieces of wood off the block until you have carved all the way around the outline and the rough shape of your Paddle Person is complete.
6. Use sandpaper to smooth your Paddle Person.
7. Carve or paint details (eyes, mouth, clothes, etc.) on your Paddle Person if you wish.

## Sample pattern for carving a paddle person

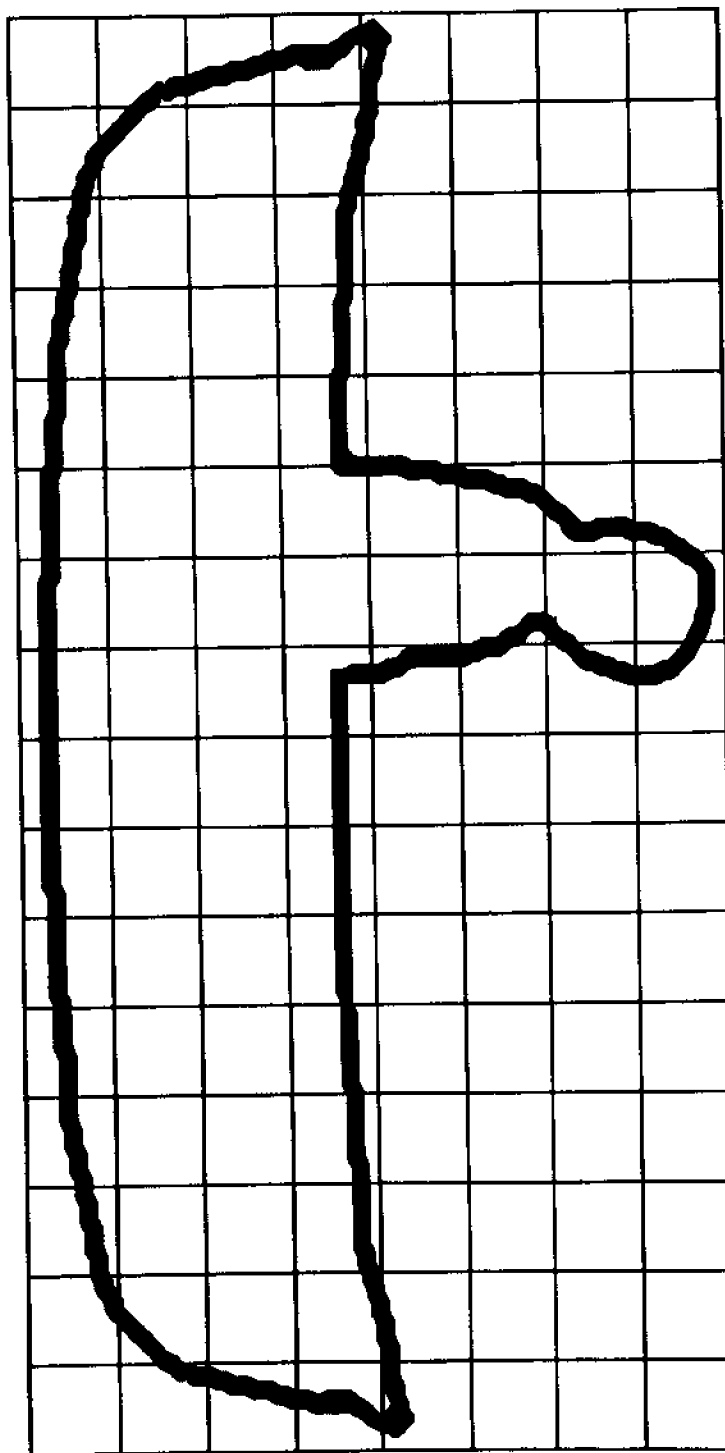

---

# In One Lake and Out Another

---

## Introduction

It took Paddle four years to travel through the Great Lakes, but it takes much longer than that for water to move through the lakes. Water is always coming into lakes from rivers and groundwater and from the atmosphere as rain or snow. Water is always running out of lakes and evaporating into the atmosphere. All these processes put together are called the **hydrologic cycle**. If a lot of water suddenly enters a large lake, it can spread out, so the water level does not change very much. If a lot of water suddenly enters a small lake, it does not have room to spread out, and floods can occur when the water level rises. As water flows from one Great Lake to another, changes in the water levels of upper lakes affect the water levels in lakes downstream.

## Objectives

When students have completed this activity, they will be able to describe the hydrologic cycle, to explain reasons why lake levels may change, and to demonstrate how changes in water levels in large lakes affect the water levels in small lakes downstream.

## Materials

Three different-sized milk cartons (for example, gallon, quart, and pint), duct tape, measuring cup, ruler, India ink, **Hydrologic Cycle** diagram and **Water Rates** worksheet (masters on pages 11-12).

## Procedure

1. Look at the **Hydrologic Cycle** diagram. Discuss the following questions.
  - \* How does water get into the Great Lakes?
  - \* Where does water go when it leaves the Great Lakes?
  - \* Does water disappear? Does “new” water ever appear?
  - \* What might change the amount of water entering or leaving a lake?  
(*For example, a dam, a diversion, ice, and snow melting.*)
  - \* What happens to a substance that can dissolve in water when it gets into a lake?
  - \* How long do you think it takes for such a substance to wash out of a lake?
2. Cut milk cartons and fasten them together with duct tape to represent a chain of three lakes. Cut a notch in each carton to allow water to flow down the chain. Use the diagram on the next page to help you build the model. Place the entire model in a sink or dishpan to catch water that might overflow.
3. Use the measuring cup to fill each “lake” with water until the water level is 3 centimeters below the bottom of the outflow notch in each carton. Use your ruler to measure the depth of the water in each lake.

4. Add one cup of water to the largest lake. Measure the depth again. How much has the water level changed?
5. Add one cup of water to the middle lake. What is the new water level in the middle lake? In which lake did the water level change more?
6. Add one cup of water to the smallest lake. What is the new water level? Did the water overflow? What can you conclude about how the size of a lake affects changes in water levels when equal amounts of water are added to each lake?
7. Add several drops of India ink to the water in the largest lake and stir gently. What has happened to the color of the water?
8. Slowly add water to the largest lake until it begins to overflow into the middle lake. What is happening to the water in the middle lake? Continue adding water to the largest lake until the water is overflowing from each lake. Describe what happens to the color of the water in each lake as more and more water is added to the system.
9. Continue adding water until the water in the largest lake looks clear again. Can you still see ink in the water of the other lakes? What can you conclude about how water-soluble pollutants are carried through lakes? (*India ink is not water-soluble, but it is used here as a visible example.*)

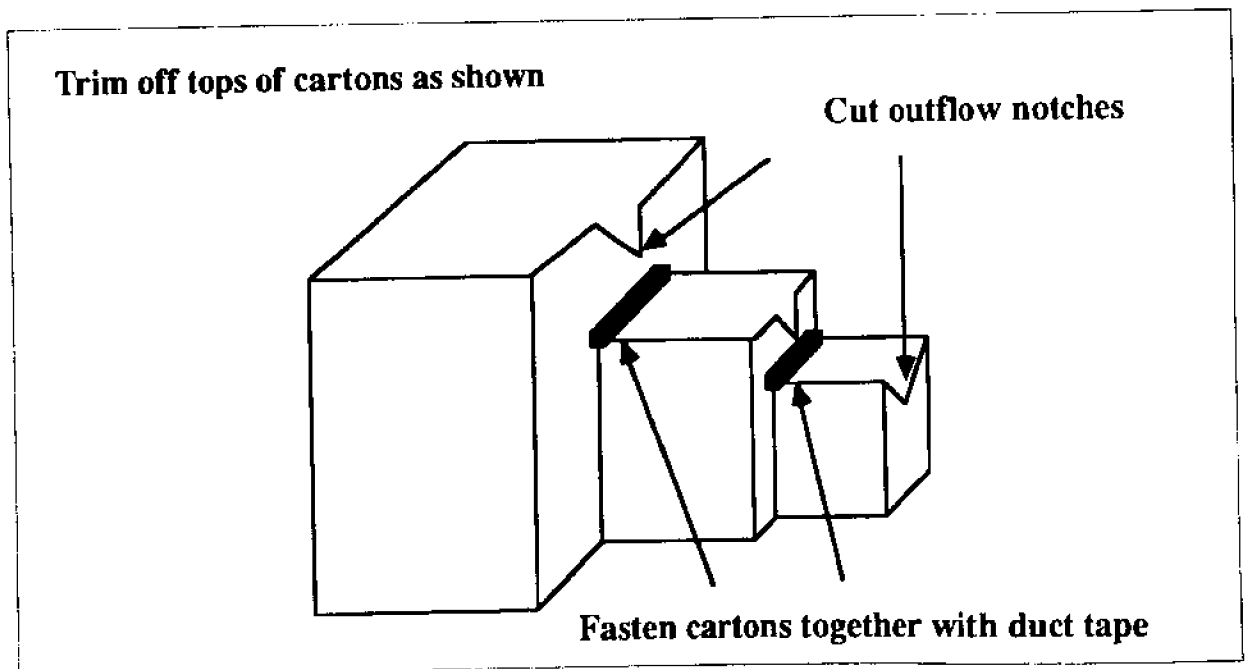

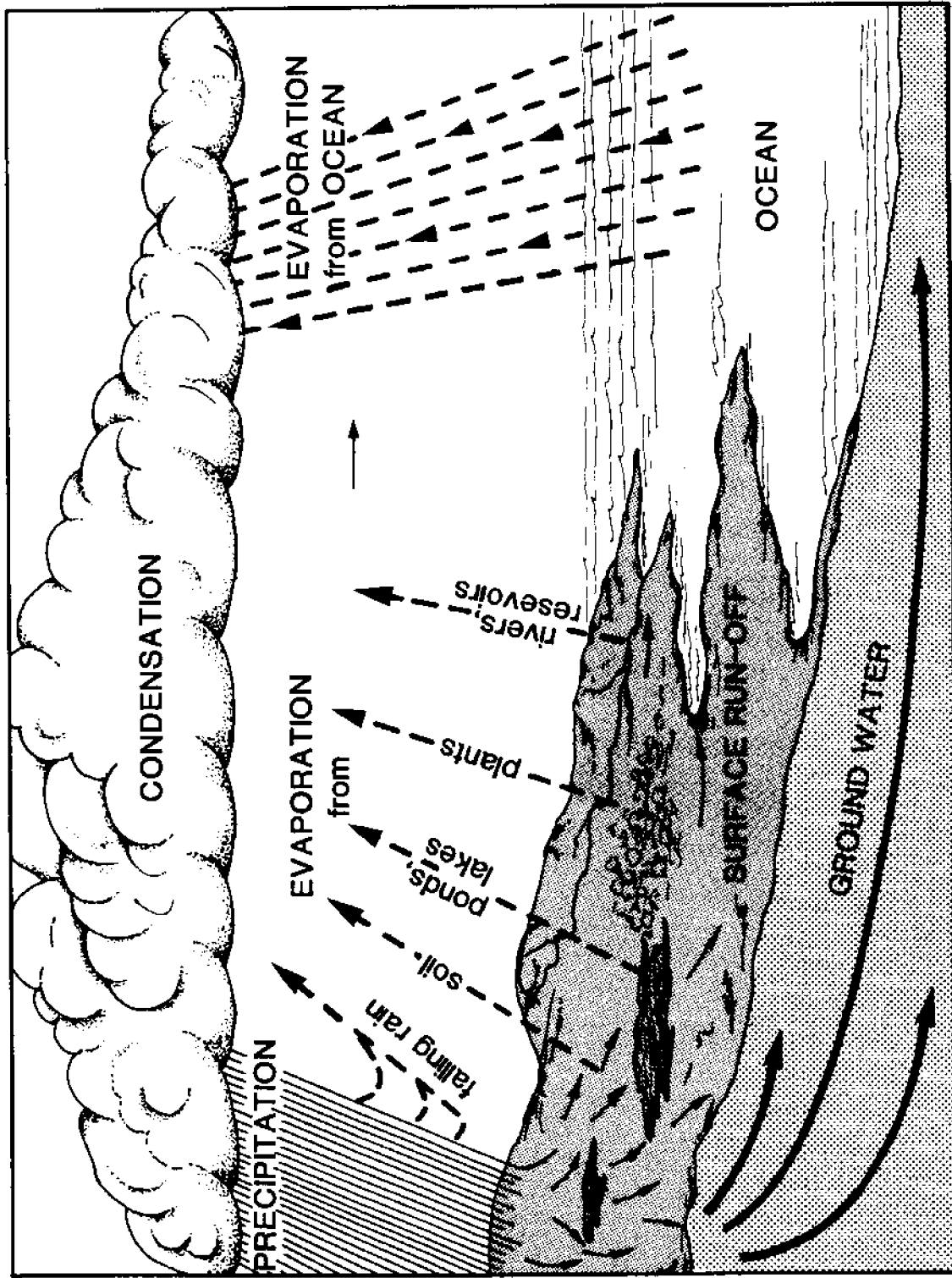

The Hydrologic Cycle

NAME \_\_\_\_\_

## Water Rates worksheet

Use the information below to answer the following questions.

Volumes of the Great Lakes (km <sup>3</sup> )	
Lake Superior	12,100
Lake Michigan	4,900
Lake Huron	3,540
Lake Erie	484
Lake Ontario	1,640

Filling times (years)	
Lake Superior	180
Lake Michigan	100
Lake Huron	23
Lake Erie	3
Lake Ontario	8

$$\text{Volume} = \text{area} \times \text{depth}$$

1. If you spread all of the water in the Great Lakes over the continent of North America, how deep would the water be? The area of the continent is approximately 21,900,00 square kilometers. Add the volumes of the Great Lakes together and divide the total by the area of North America to calculate this depth.
2. The area of Lake Erie is 25,700 square kilometers. How deep would Lake Erie have to be to hold all of the water in Lake Superior? Divide the volume of Lake Superior by the area of Lake Erie to calculate this depth.
3. Because water entering a lake mixes with water already in the lake, it takes a very long time for water-soluble substances to wash out of lakes. It takes about three times longer to wash 90% of a soluble substance out of a lake than it takes to fill the lake. If you poured a cup of salt into Lake Superior, how long would it take for 90% to wash downstream? How long would it take for 90% of the same salt to wash through the Great Lakes and out of Lake Ontario? Calculate the 90% removal times for each of the Lakes by multiplying their filling times by 3. Add these times together to find out how long it would take to wash 90% of the salt out of the Great Lakes. What does this tell you about pollutants entering the Great Lakes?



# ANSWER KEY — Water Rates worksheet

Use the information below to answer the following questions.

Volumes of the Great Lakes (km <sup>3</sup> )	
Lake Superior	12,100
Lake Michigan	4,900
Lake Huron	3,540
Lake Erie	484
Lake Ontario	1,640

Filling times (years)	
Lake Superior	180
Lake Michigan	100
Lake Huron	23
Lake Erie	3
Lake Ontario	8

$$\text{Volume} = \text{area} \times \text{depth}$$

1. If you spread all of the water in the Great Lakes over the continent of North America, how deep would the water be? The area of the continent is approximately 21,900,000 square kilometers. Add the volumes of the Great Lakes together and divide the total by the area of North America to calculate this depth.

$$\text{Total volume} = 22,664 \text{ km}^3$$

$$\text{Depth} = 22,664 \text{ km}^3 \div 21,900,000 \text{ km}^2 = 0.001 \text{ km or 1 meter}$$

2. The area of Lake Erie is 25,700 square kilometers. How deep would Lake Erie have to be to hold all of the water in Lake Superior? Divide the volume of Lake Superior by the area of Lake Erie to calculate this depth.

$$12,100 \text{ km}^3 \div 25,700 \text{ km}^2 = 0.47 \text{ km or 470 meters}$$

3. Because water entering a lake mixes with water already in the lake, it takes a very long time for water-soluble substances to wash out of lakes. It takes about three times longer to wash 90% of a soluble substance out of a lake than it takes to fill the lake. If you poured a cup of salt into Lake Superior, how long would it take for 90% to wash downstream? How long would it take for 90% of the same salt to wash through the Great Lakes and out of Lake Ontario? Calculate the 90% removal times for each of the Lakes by multiplying their filling times by 3. Add these times together to find out how long it would take to wash 90% of the salt out of the Great Lakes. What does this tell you about pollutants entering the Great Lakes?

*90% of removal times:*

$$\text{Lake Superior} \quad 180 \times 3 \quad = 540 \text{ years}$$

$$\text{Lake Michigan} \quad 100 \times 3 \quad = 300 \text{ years}$$

$$\text{Lake Huron} \quad 23 \times 3 \quad = 69 \text{ years}$$

$$\text{Lake Erie} \quad 3 \times 3 \quad = 9 \text{ years}$$

$$\text{Lake Ontario} \quad 8 \times 3 \quad = 24 \text{ years}$$

---

$$\text{TOTAL} \quad \quad \quad = 942 \text{ years}$$

---

# How Big is a Crowd?

---

## Introduction

As Paddle travelled through the Great Lakes, he passed by forested wilderness areas and cities where thousands of people live. The Great Lakes and the surrounding land provide many resources for the people who live in the area. Water for drinking and industry, fish for food, minerals, and other resources are abundant. But people create wastes and add chemicals to the environment when they use resources, and these can be harmful. When many people are concentrated in one area, they may compete for scarce resources. In addition, the wastes these people generate tend to concentrate in the area immediately around them and may cause pollution problems.

## Objectives

When students have completed this activity, they will be able to list the relative areas and relative human populations of the five Great Lakes and to describe some of the problems that arise when many people need a limited resource.

## Materials

Ball of string; masking tape; area, population and **Fish Production tables** (master on page 133); 100 (minimum) Hershey kisses or peanuts in shells; 5 paper bags.

## Advance Preparation

1. Cut lengths of string and tie the ends together to make loops proportional to the areas of the five Great Lakes. Suggested lengths in meters are given for groups of less than thirty and more than thirty participants (less/more).

Lake Superior	8.5 / 11.0 m
Lake Michigan	6.0 / 7.5 m
Lake Huron	6.0 / 7.5 m
Lake Erie	2.5 / 3.0 m
Lake Ontario	2.0 / 2.5 m
2. Decide how many students will be “populating” each of the lakes. Use the chart on the next page to assign numbers of students to represent the relative numbers of people living around each lake. Numbers are given for both United States and Canadian residents (U.S./Canada). Remember that Lake Michigan is the only Great Lake which shares no border with Canada.

## NOTE

You may want to invite another class to share in this activity, especially if your class has less than twenty people in it. Larger numbers of participants better illustrate the differing concentrations in population throughout the Great Lakes region.

<b>Number of people</b>								
U.S./Canada								
<b>Total participants</b>	<b>15</b>	<b>20</b>	<b>25</b>	<b>30</b>	<b>35</b>	<b>40</b>	<b>45</b>	<b>50</b>
<b>Lake Superior</b>	0/0	0/0	0/0	1/0	1/0	1/0	1/0	1/0
<b>Lake Huron</b>	1/0	1/1	1/1	1/1	1/1	2/1	2/1	2/1
<b>Lake Ontario</b>	1/2	1/3	2/3	2/4	2/4	2/5	3/5	3/6
<b>Lake Erie</b>	4/1	5/1	8/1	8/2	11/2	12/2	13/3	15/3
<b>Lake Michigan</b>	6/0	7/0	9/0	11/0	13/0	15/0	17/0	19/0

3. Divide Hershey Kisses or peanuts in shells into groups representing the proportional number of fish caught annually in each of the Great Lakes. You will need at least 100 Kisses or peanuts. One Kiss or peanut represents approximately 50 tons of fish. Label the five bags with the names of the five lakes and use the table below to put the correct number of "fish" in each bag. (For groups of less than 25 students, you may want to halve these numbers.)

Lake Superior	8
Lake Michigan	35
Lake Huron	5
Lake Erie	50
Lake Ontario	2

### Procedure

- Look at the tables of information about the Great Lakes and discuss the following questions:
  - \* Which of the lakes has the largest area? Which has the smallest?
  - \* Which lake has the largest population? Which has the smallest?
  - \* Are more people living near the eastern or the western lakes?
  - \* Are more people living near the United States or the Canadian shores?
  - \* Which lake produces the most fish? Which produces the least?
  - \* Where would you go if you wanted to catch fish?
- Make an "international border" on the floor with a strip of tape. Arrange the loops of string that represent the five Great Lakes along the border from left to right according to the diagram on the next page.

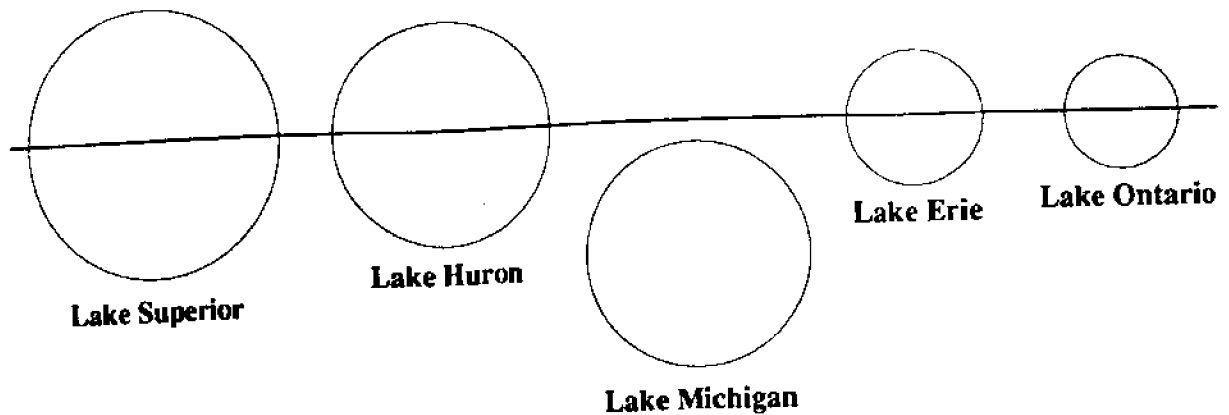

3. Assign the appropriate numbers of participants to the United States and Canadian sides of each of the lakes. (An alternative is to assign participants to each lake without specifying a country; in this case you do not need the tape border.) Each participant should put one foot on the string "shore" of the lake. Where are people closest together? Did anyone have a hard time finding room to stand? On which lake or lakes do you think the biggest cities are located?
4. Pass the appropriate bag of "fish" around each lake. Each person takes ONE Kiss or peanut each time the bag is passed to him or her until the bag is empty. (If you have no one assigned to Lake Superior, set aside that bag and do not distribute those "fish" in the other lakes.) Which lake had the most "fish"? In which lake did people catch the most? Why do you think this is so?
5. People create waste when they use resources, and much of that waste is carried by water. Too much waste causes pollution problems. Open and eat your "fish." Put the foil wrappers or peanut shells on the floor inside the loop of string that is your lake. Which lake is the waste most concentrated (closest together)? Remember that the water from each lake flows into the lake downstream (in this case, to the right) of it. In which lake or lakes do you think might have the worst pollution problems? Why do you think so?
6. Clean up and discuss the activity together.

## **Discussion Questions**

1. What relationships have you seen between population, resources, and waste?
2. What could you have done to make sure ALL participants got an equal number of "fish"? (*Sell or trade for other resources or services, for example.*)
3. How do you think the amount of pollution in the Great Lakes could be reduced?
4. How could you reduce the amount of waste you produce?

## **Extension Activities**

Play math games with Great Lakes areas and populations. For example, find out how many times Lake Erie could fit in one Lake Superior, how many people per square meter there are in each lake, and so on. Or organize a **Clean Campaign** (page 107) to learn more about recycling.

## **Additional Information**

### **The Great Lakes: An Environmental Atlas and Resource Book.**

Jointly produced by the U.S. Environmental Protection Agency and Environment Canada. Copies are available free of charge from:

**Great Lakes National Program Office  
U.S. Environmental Protection Agency  
230 South Dearborn Street  
Chicago, Illinois 60604**

**or**

**Conservation and Protection, Ontario Region  
Great Lakes Environment Program  
Environment Canada  
25 St. Clair Avenue East  
Toronto, Ontario, Canada M4T 1M2**

**Water Surface Areas of the Great Lakes**  
(km<sup>2</sup>)

Lake	Area
Lake Superior	82,100
Lake Michigan	57,800
Lake Huron	59,600
Lake Erie	25,700
Lake Ontario	18,960

**Great Lakes Population**  
(as of 1981)

Lake	Canada	United States	Total
Lake Superior	180,440	558,100	738,540
Lake Michigan	0	13,970,900	13,970,900
Lake Huron	1,051,119	1,321,000	2,372,119
Lake Erie	1,621,106	11,347,500	12,968,606
Lake Ontario	4,551,875	2,090,300	6,642,175

**Average Annual Catch of Fish**  
(tons)

Lake	Annual catch
Lake Superior	400
Lake Michigan	1,800
Lake Huron	280
Lake Erie	2,600
Lake Ontario	100

---

# Rivers in the Air

---

## **Introduction**

Throughout the story, Holling describes how Paddle is carried along by currents. Currents in the water of the pond carried Paddle around its shores; currents carried him around the shores of Lake Superior and up the shore of Lake Michigan. Currents act like rivers within a body of water such as a lake or pond. There are also currents in the air, caused by winds. Air currents also act like rivers to carry floating objects (balloons, for example) from place to place.

## **Objectives**

When they have completed this activity, students will be able to explain how air currents act like rivers to carry floating objects.

## **Materials**

Fan, soap bubbles (buy the bubble solution and bubble ring at most stores where toys are sold, or make your own solution of dish soap and water, and use a small circle of thin wire as a bubble ring).

## **Procedure**

1. Practice making bubbles with the bubble ring. Observe how the bubbles float and move in the air. Try blowing the bubbles from place to place with your breath. What happens to the bubbles?
2. Set up the fan in one corner of the room and turn it on to its lowest setting. This simulates a steady current of wind in the classroom.
3. Make bubbles and release them in the current of air in front of the fan. Observe how the bubbles move in this air stream. Where do they go? How fast do they move? Do they always move in the same direction?
4. Try releasing the bubbles above the fan, below it, or beside it, as well as in front of it. Observe how the bubbles move now.
5. Turn the fan speed up and repeat the experiment. Now what happens to the bubbles? Do they move in the same direction that they did at the lower speed? Do they move the same distance?

### Discussion Questions

1. What happened to the bubbles you released in still air (before the fan was turned on)?
2. What happened to the bubbles you released in front of the fan? How did they move?
3. Was there any difference in the way the bubbles moved when you released them above, below, or beside the fan? Why do you think this might be so?
4. Compare the way the bubbles moved in the air stream with the way you have seen objects move in water currents. How does the wind act like a river in the air?
5. When the fan was turned to the higher setting, what happened to the bubbles? What does this tell you about the strength of the wind created by the fan?
6. Paddle was carried along by water currents, but sometimes winds pushed him backward. How do wind currents help people move from one place to another? Can you think of ways that wind currents might keep people from moving ahead?
7. How do people use the power of winds to do work? (*Some examples are sailboats, windmills to pump water or generate electricity, hang gliders.*)
8. Are wind currents and water currents related?
9. Suppose bubbles lasted forever. Would this create problems in our world?



---

# Tour by Mail

---

## Introduction

The Indian boy wanted to travel to the sea. Since he couldn't go himself, he carved Paddle to take the journey for him. Paddle travelled to many places on his way through the Great Lakes to the sea. We can "visit" many of these places ourselves without ever leaving home. We can write letters to people who live in the places we would like to visit, asking them to send us information about where they live.

## Objective

When students have completed this activity, they will be able to write a business letter correctly.

## Materials

List of addresses (on page 22), paper, envelopes, stamps.

## Procedure

1. Write to the Chambers of Commerce of various Great Lakes cities, or to the tourism bureaus of the states and provinces mentioned in the story. Some useful addresses are listed on the next page. Consult your telephone directory for local addresses.
2. Keep these guidelines in mind when you write your letters:
  - \* Send **one** request from the class to each person or agency.
  - \* Ask for specific information: What attracts tourists to this area? How many people live in this city (state, province)? What industries are located there? What are the most important products of the area?
  - \* Send a self-addressed, stamped envelope with your request. This will make it easier for the agency to answer your letter.
  - \* Plan to wait two or three weeks after sending your letters for your requested information to arrive.
3. Use this basic format to write a correct business letter to each agency:

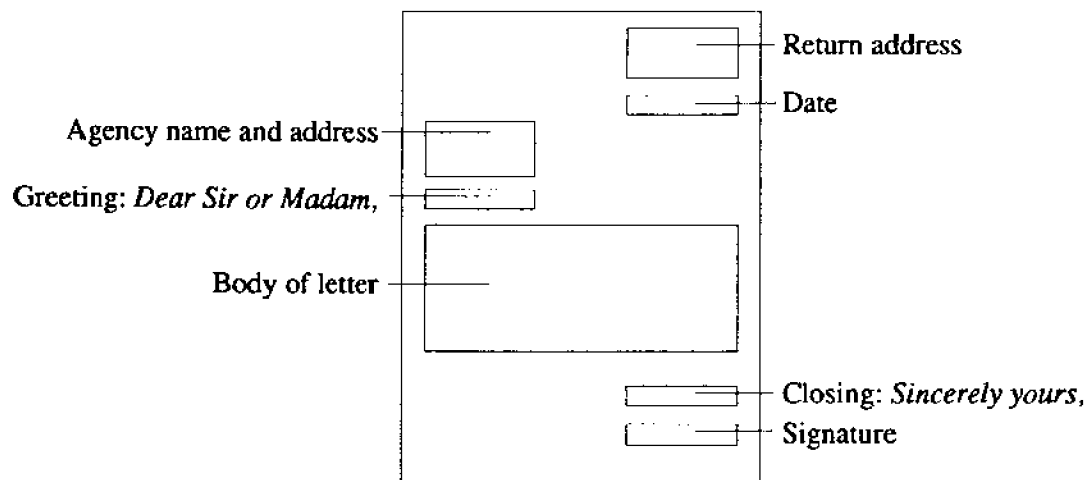

4. Many Chambers of Commerce and tourism bureaus will send colorful brochures or post cards to advertise their major attractions. You may want to make a bulletin board to display these advertisements, or attach them to the appropriate areas on your wall map of Paddle's voyage. Compare and contrast the advertisements from different places.

## **Selected Addresses**

**Greater Cleveland Growth Association**  
690 Huntington Building  
Cleveland, Ohio 44115

**Toledo Area Chamber of Commerce**  
218 North Huron Street  
Toledo, Ohio 43604

**Ohio Department of Development**  
Office of Travel and Tourism  
30 East Broad Street  
Columbus, Ohio 43216

**Ontario Travel**  
Queen's Park  
Toronto, Ontario, Canada M7A 2E5

**Minnesota Department of Economic  
Development**  
51 East 8th Street  
St. Paul, Minnesota 55101

**Wisconsin Department of Natural Resources**  
Box 450  
Madison, Wisconsin 53701

**Michigan Tourist Council**  
300 South Capitol Avenue  
Lansing, Michigan 48926

**Illinois Adventure Center**  
160 North La Salle  
Chicago, Illinois 60601

**Indiana Tourist Development Division**  
336 State House  
Indianapolis, Indiana 46204

**Pennsylvania Bureau of Travel Development**  
400 South Office Building  
Harrisburg, Pennsylvania 17120

**New York Travel Bureau**  
99 Washington Street  
Albany, New York 12245

**Tourisme Quebec**  
12 Sainte Anne Street  
Quebec City, Quebec, Canada G1R 3X2

**Tourism New Brunswick**  
PO Box 1030  
Fredericton, New Brunswick, Canada E3B 5C3

**Nova Scotia Department of Tourism**  
PO Box 130  
Halifax, Nova Scotia, Canada B3J 2M7

**Prince Edward Island**  
Tourist Information Division  
PO Box 940  
Charlottetown, Prince Edward Island, Canada C1A 7M5

---

# Time Line

---

## Introduction

Paddle's journey to the sea took a long time, and many things happened to him on the way. We use calendars to help us keep track of time and events, but they usually show us only one month at a time. A time line is another way to keep track of time. It is a continuous record of events that happen over time, like placing the pages of a calendar side by side instead of one on top of the other. A time line would show us at a glance how long it took Paddle to reach the sea and what kinds of things happened to Paddle during each season of his journey.

## Objectives

When students have completed this activity, they will be able to tell how long it took Paddle to reach the sea and to list the major events that occurred during each season that passed. **NOTE:** You can make one time line for the whole class or have each student make one.

## Materials

Long strip of paper (rolls of newsprint, shelf paper, or computer paper are ideal), markers or crayons.

## Procedure

1. Begin your time line at the left edge of the paper. Since Paddle's journey begins in the spring, write "Spring" at the beginning of your time line.
2. Working from left to right, add events and seasons to the time line as you read the book. A summary of the major events in each season is provided on the next page.
3. Illustrate the time line with drawings of Paddle's adventures.

## Discussion Questions

1. How long did it take for Paddle to reach the sea?
2. What kinds of things happened to Paddle in each season?
3. What animals did Paddle meet? Where did he meet them?
4. What people did Paddle meet? What were they doing?
5. How many cities did Paddle visit?
6. In what order did Paddle pass through the Great Lakes?
7. Where did Paddle's journey finally end?

# Seasonal Summary of Main Events

## **SPRING 1**

Paddle's journey begins  
Paddle travels through the beaver pond  
Paddle is carried to the sawmill with the logs  
The lumberjack saves Paddle

## **SUMMER 1**

Paddle reaches Lake Superior  
Paddle is trapped in the marsh  
Paddle passes Duluth, Minnesota, and Superior,  
Wisconsin  
Paddle is stained red from iron dust  
Paddle is caught with the fish in the Apostle  
Islands

## **FALL 1**

Paddle passes Keweenaw Peninsula  
Paddle gets tossed ashore and washed back into  
the lake by storms  
The ship is wrecked in Whitefish Bay  
Paddle gets tossed ashore and picked up by the  
Coast Guard crew  
Bill repairs Paddle

## **WINTER 1**

Paddle rides the dogsled to The Soo  
Maloney keeps Paddle on the ore boat until  
Spring

## **SPRING 2**

Paddle goes to Gary, Indiana, on the ore boat  
Paddle is dropped overboard with Maloney's  
laundry

## **SUMMER 2**

Paddle travels north through Lake Michigan

## **FALL 2**

Paddle survives the forest fire

## **WINTER 2**

Paddle skates over Lake Huron

## **SPRING 3**

Paddle drifts south through Lake Huron

## **SUMMER 3**

Paddle reaches Bay City, Michigan  
Paddle gets a boat ride through Lake St. Clair to  
Detroit and then to Lake Erie  
Paddle travels through Lake Erie to Buffalo

## **FALL 3**

Paddle goes over Niagara Falls  
Paddle gets caught in the whirlpool  
Paddle travels through Lake Ontario

## **WINTER 3**

Paddle stays with the old lady in Montreal

## **SPRING 4**

Paddle travels down the St. Lawrence River  
Paddle is caught in the tides in the Gulf of  
St. Lawrence

## **SUMMER 4**

Paddle rides the Gulf Stream to the Grand Banks  
Paddle reaches the sea  
Paddle is picked up by the French fishing boat

## **SPRING 5**

French newspaper with Paddle's story arrives in  
Nipigon country

---

# What Do You "See" in the Great Lakes?

---

## **Introduction**

As Paddle travels through each of the five Great Lakes, Holling describes a "picture" that he imagined in the outline of the shape of each lake. Lake Superior made Holling think of a wolf's head, Lake Michigan appeared to be a squash with its leaves, and so on. Use your imagination to see what Holling saw in the shape of each lake. Do you see any different pictures in these outlines?

## **Objective**

When the students have completed this activity, they will be able to identify the shape of each of the five Great Lakes.

## **Materials**

Outlines of each lake (masters on pages 26-30) for each student, sample pictures drawn by the author, markers or crayons.

## **NOTE**

You may wish to complete this activity for all five Great Lakes as part of a general introduction to the story. Or repeat the activity for each lake as Paddle's travels carry him through it.

## **Procedure**

1. Give each student an outline of one of the lakes. If you are using this as a general introduction, you may wish either to have everyone use the same shape at the same time (see how many different pictures students see in the same shape) or divide the class into groups to work on all five lakes at the same time.
2. Examine Holling's pictures of what he saw in each lake. Look for the details that help each outline to become a whole picture.
3. Think about what you can see in the shape of each lake. Draw details in the outline to complete your picture. Did you see any different pictures than Holling did in each lake?
4. Share your lake picture(s) with the class. How many different pictures did you discover for each lake?
5. Test your memory. Can you identify each lake by shape? Take turns choosing a blank outline and have others name it, or name a lake and have others choose the correct outline.

## **Extension**

Look at maps in an atlas for other geographic features whose shapes suggest pictures to you (examples: Italy looks like a boot, Lake St. Clair is heart-shaped). Trace the outlines of these features and fill in details to complete new pictures from these shapes.

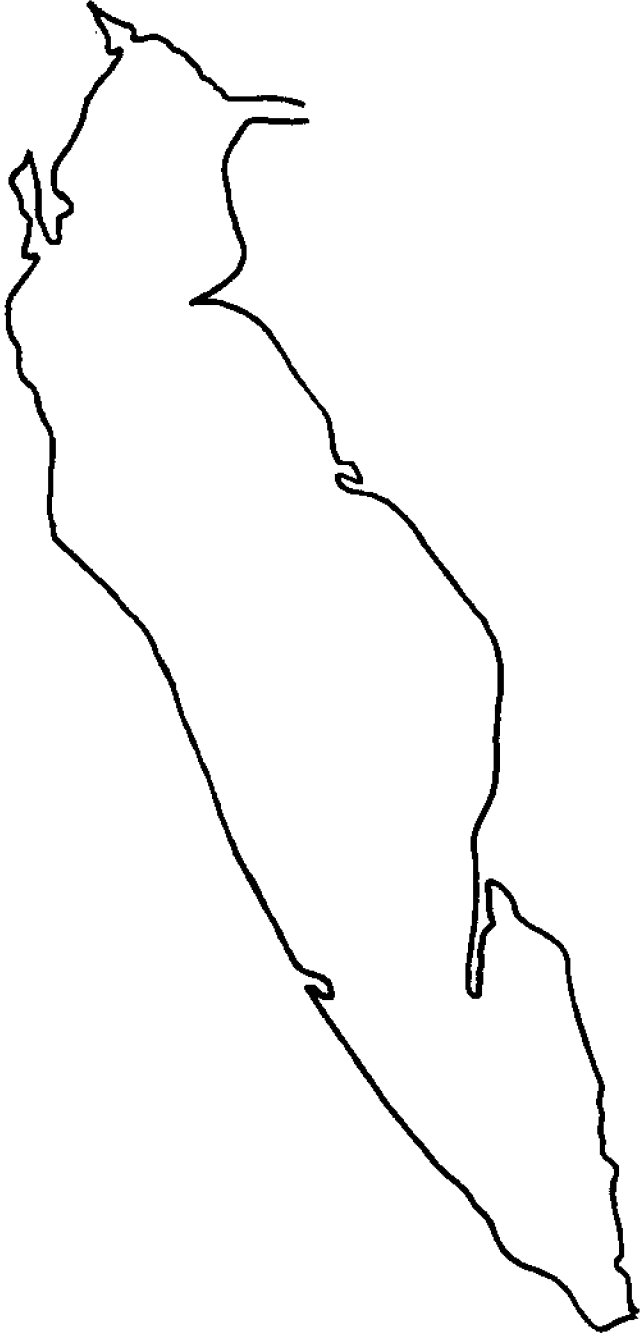

**Lake Erie**

# Lake Michigan

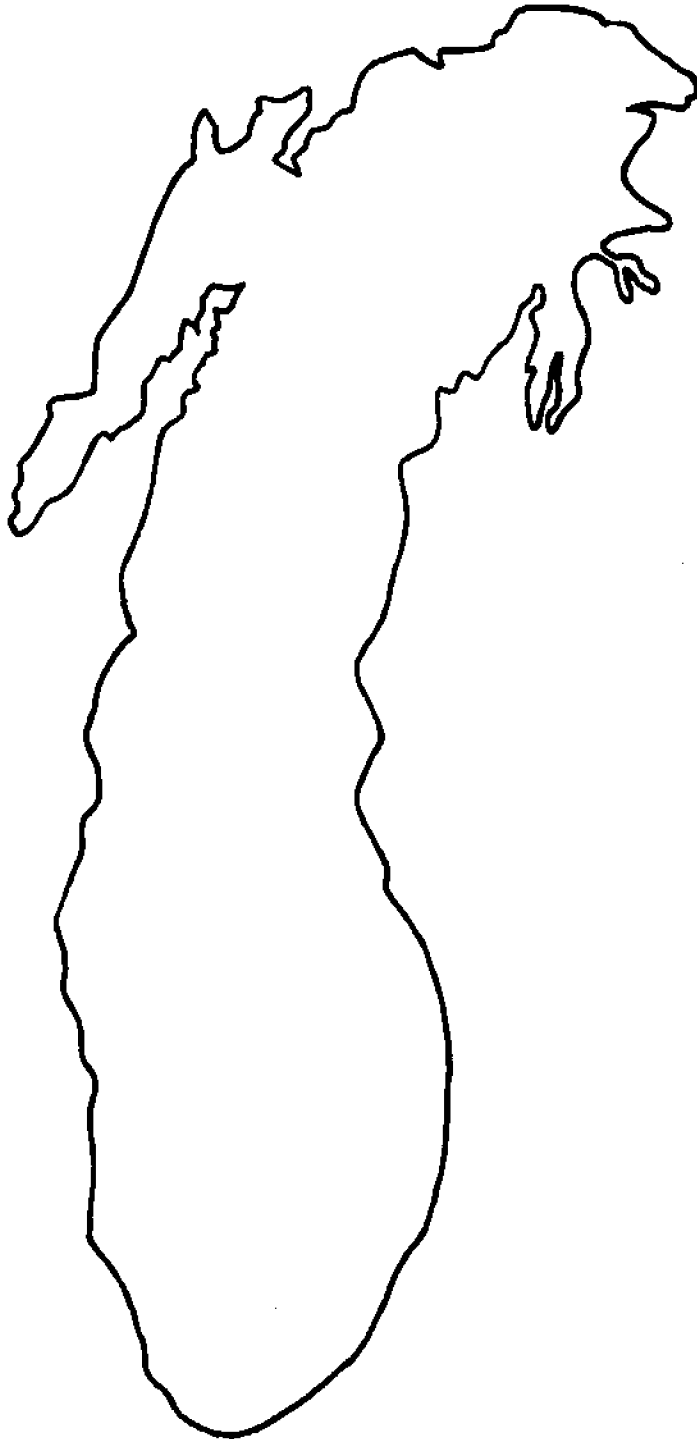

---

## Lake Huron





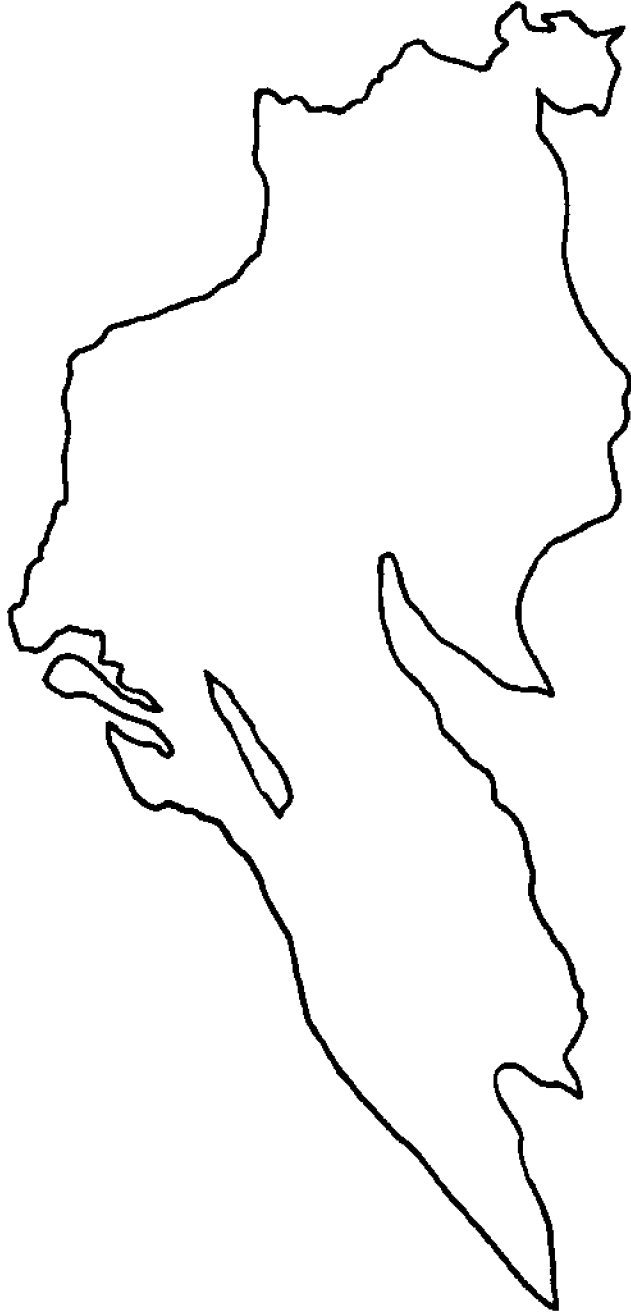

**Lake Superior**

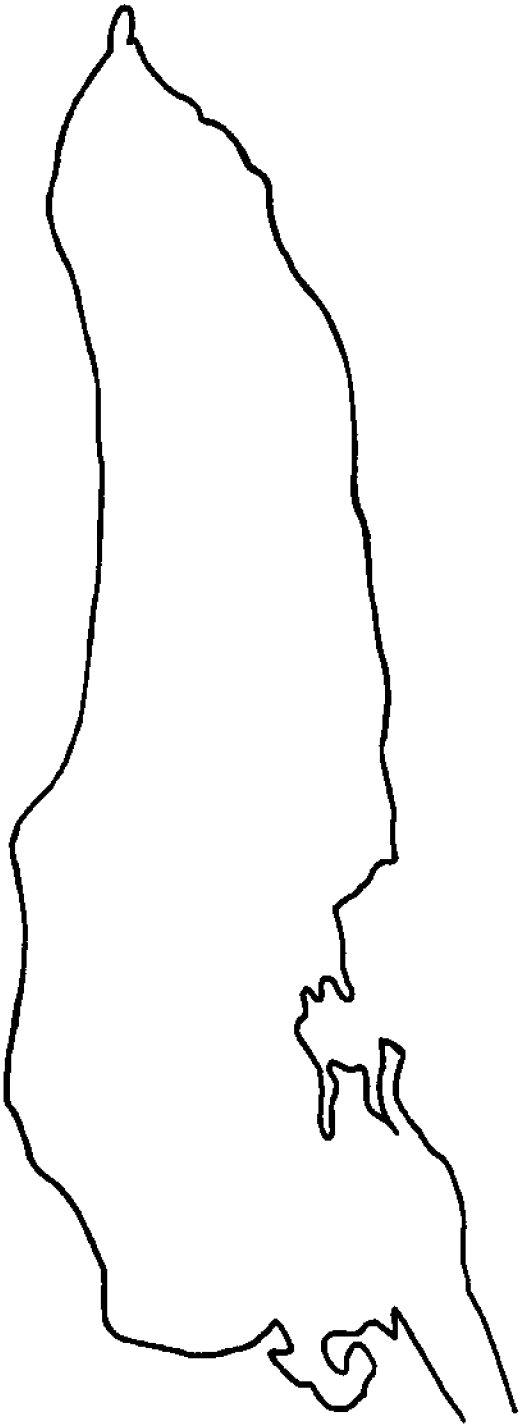

**Lake Ontario**

---

# Taken by Surprise

---

## Introduction

The Indian boy had been working on his Paddle Person during the winter. He wanted to send Paddle on his journey in the spring. Suddenly, he heard geese flying overhead, returning to the North. Spring was coming soon, but his Paddle Person wasn't ready yet! He would have to work quickly to finish his project before the ice melted. People are often taken by surprise when they are trying to get something done. Many times people must meet deadlines to finish a project. Have you ever been in such a situation?

## Objectives

When the students have completed this activity, they will be able to list the six basic questions a story should answer. They will write and illustrate a story which answers these basic questions.

## Materials

Paper, pencil or pen, markers or crayons.

## Procedure

1. Discuss with students what they expect to find out when they read any story. Six basic questions should be mentioned:
  - \* **WHO** is the story about?
  - \* **WHAT** is happening in the story?
  - \* **WHY** do these things happen?
  - \* **WHEN** is it happening?
  - \* **WHERE** does the story take place?
  - \* **HOW** is the problem solved? (How does the story end?)
2. Read Chapter 1, *How Paddle-to-the-Sea Came To Be*. Discuss possible answers to these six basic questions from information in the chapter.
3. Write a short story about someone being taken by surprise or trying to meet a deadline. It can be about something that actually happened to you or someone you know, or you can make up a situation. Remember the six basic questions your story should answer.
4. Draw a picture to illustrate your story. What basic question(s) have you answered with your drawing?
5. Share the stories with the class. Read each one aloud, then discuss it. Have the class list the six basic questions, then answer them for each story.

---

# Animal Snowshoes

---

## Introduction

The Indian boy used snowshoes to help him move over the snow when he went to check on Paddle. When he got there, he saw the tracks of many animals in the snow. Moving through deep snow can be difficult for many animals, but some have specially adapted feet to help them move more easily during a snowy winter. These animals have feet which are very large compared to their body size—feet like snowshoes. Instead of sinking into the snow and pushing through it to move, animals with snowshoe feet can move over the snow without sinking in, so they use less energy to go from place to place. In general, the larger an animal's feet are in proportion to its weight, the less it will sink into snow. This means that if two animals weigh the same, the one with smaller feet will sink farther into snow than the one with bigger feet.

## Objectives

When the students have completed this activity, they will be able to define pressure in terms of body weight and foot area and to explain how some animals' feet act as snowshoes.

## Materials

Ruler, pencil, plain paper, graph paper, diagrams of **Animal Tracks** (pages 40-44), **Animal Snowshoes** worksheet (master on pages 34-35).

## Terms to Know

**Pressure**—the amount of weight per unit area; how hard something pushes against something else. For this activity,

$$\text{Pressure} = \frac{\text{body weight in kilograms}}{\text{foot area in square centimeters}}$$

## Advance Preparation

On the day before you do this activity, have each student find out his/her own weight. You may be able to use a scale in the school gym or the health office.

## Discussion Questions

1. What animals visited Paddle on the hillside?
2. Which of these do you think would sink farthest into the snow? Which one would not sink very much at all? Why do you think so?
3. What happens to you when you try to walk through deep snow? Why do you think the Indian boy used snowshoes instead of regular boots to walk through the snow?

## Procedure

1. Use the animal track diagrams to calculate the approximate foot area for different animals. Record the information on the worksheet. First measure the height of the hind foot print in centimeters, then measure the width of the hind print. Multiply the height by the width to get the approximate foot area in square centimeters. If the front print is a different size than the hind print, measure its height and width also and multiply them to calculate its area. Remember, these animals have four feet, so you will need to add together the areas for both hind feet and both front feet (four in all) to calculate the total foot area. Fill in the chart for each animal.
2. Now calculate our own foot area. Use a pencil to trace the outline of your bare foot on a piece of paper. Measure the height and width (at the widest point) of your footprint and calculate its area. Multiply by two (you have two feet) to calculate your total foot area and write this total on the chart.
3. Now find your own weight in kilograms. If you measured your weight in pounds, divide by 2.2 to calculate your weight in kilograms. Fill in your weight in kilograms on the chart. The average weight of each animal in kilograms has already been filled in for you.
4. Now you are ready to calculate the pressure that each animal exerts as it stands on a surface. Divide each animal's weight by its total foot area. Fill in the pressure column on your chart. Don't forget to calculate your own pressure!
5. Calculate the pressure you would exert if you were wearing a pair of snowshoes that are **60 cm long** and **35 cm wide**. What is the total area of your snowshoes? Divide your weight by the area of your snowshoes to calculate your new foot pressure. Is your foot pressure greater with snowshoes or without?
6. Graph your results. Put **WEIGHT** along the X-axis (horizontal) and **PRESSURE** along the Y-axis (vertical). For each animal, make a point on the graph where its weight and its foot pressure intersect. What can you conclude about the size of feet in determining foot pressure? Can two animals of different weights exert the same pressure? How would this be possible? How can two animals of the same weight exert different pressures?

NAME \_\_\_\_\_

## Animal Snowshoes worksheet

Animal	Hind foot area (cm <sup>2</sup> ) (height x width) x 2	Total foot area (cm <sup>2</sup> )	Weight (kg)	Foot Pressure (kg/cm <sup>2</sup> ) body weight ÷ total foot area
White-footed mouse	Front foot area (cm <sup>2</sup> ) (height x width) x 2		0.10	
Weasel	Front foot area (cm <sup>2</sup> ) (height x width) x 2		0.65	
Wolf	Front foot area (cm <sup>2</sup> ) (height x width) x 2		42	
Wolverine	Front foot area (cm <sup>2</sup> ) (height x width) x 2		28	

## Animal Snowshoes worksheet

Animal	<b>Hind foot area (cm<sup>2</sup>)</b> (height x width) x 2	<b>Total foot area (cm<sup>2</sup>)</b>	<b>Weight (kg)</b>	<b>Foot Pressure (kg/cm<sup>2</sup>)</b> body weight ÷ total foot area
Rabbit	<b>Front foot area (cm<sup>2</sup>)</b> (height x width) x 2		<b>1.80</b>	
Animal	<b>Hind foot area (cm<sup>2</sup>)</b> (height x width) x 2	<b>Total foot area (cm<sup>2</sup>)</b>	<b>Weight (kg)</b>	<b>Foot Pressure (kg/cm<sup>2</sup>)</b> body weight ÷ total foot area
Moose	<b>Front foot area (cm<sup>2</sup>)</b> (height x width) x 2		<b>515</b>	
Self	<b>Foot area (cm<sup>2</sup>)</b> (height x width) x 2	<b>Total foot area (cm<sup>2</sup>)</b>	<b>Weight (kg)</b>	<b>Foot Pressure (kg/cm<sup>2</sup>)</b> body weight ÷ total foot area
Self with snowshoes	<b>Foot area (cm<sup>2</sup>)</b> (height x width) x 2	<b>Total foot area (cm<sup>2</sup>)</b>	<b>Weight (kg)</b>	<b>Foot Pressure (kg/cm<sup>2</sup>)</b> body weight ÷ total foot area

---

## Tracking a Good Story

---

### Introduction

Many animals came to look at Paddle while he was on the snowbank. The Indian boy knew what animals had been there because he recognized their tracks in the snow. Animal tracks tell a story. Tracks show what animals have been in certain places, which way they were travelling, how fast they were moving, and if they were alone or with others. Look for animal tracks in snow during the winter or in muddy areas when there is no snow on the ground.

### Objectives

When the students have completed this activity, they will be able to identify pictures of tracks of the animals mentioned in Chapter 3 and use pictures of animal tracks to tell a story.

### Materials

Pictures of **Animal Tracks** and **Sample track picture story** (pages 40-44), drawing paper and pencil for each student or group of students, **Animal Print Identification** worksheet (master on page 38).

### Terms to Know

**Print**—mark left by a single paw

**Track**—set of prints; shows direction and speed of motion

### Procedure

1. Study the pictures of animal prints and tracks. Toe marks in tracks are a clue to the direction in which the animal was travelling; the toe marks will be at the front of each print. The distance between tracks is a clue to how fast the animal was moving; usually, the farther apart the tracks, the faster the animal's speed.
2. Discuss the following questions:
  - \* Are any of these prints similar to ones you have seen before? Which ones?  
(For example, wolf is similar to dog, moose is similar to deer)
  - \* How are these prints and tracks alike and different?
  - \* Two of these animals belong to the same family. Can you identify them by comparing their prints?  
(Weasel and wolverine belong to the same family—both have five toes on front and hind feet)
3. Complete the **Print Identification** worksheet.



4. Study the **Sample Track picture story**. Discuss the following questions:
  - \* What animals were involved? Why do you think so?
  - \* Which way was each animal moving? How can you tell?
  - \* How fast was each animal moving? How can you tell?
  - \* Can you tell what happened? Why do you think so?

*(Rabbit sees wolf. Rabbit runs away from wolf. Wolf chases rabbit.)*
  
5. Have students work individually or in groups of two or three to draw their own track picture stories. Students must decide what animals will be involved and what will happen to each, then draw the story using only pictures of tracks. When the pictures are complete, show each picture to the class and have students try to “read” each other’s picture stories. Use the discussion questions above to help students interpret the stories.

#### **Additional Information**

*A Guide to Nature in Winter*, by Donald Stokes. Boston, Massachusetts: Little, Brown & Company, 1976.

*A Natural History Guide*, by Herbert Laun. Alton, Illinois: Alsace Books and Films, 1967.

*Track Finder*, by Dorcas Miller. Berkeley, California: Nature Study Guild, 1981.

NAME \_\_\_\_\_

## Animal Print Identification worksheet

Match the picture of each hind foot print with the name of the correct animal.



**WOLF**



**MOUSE**



**RABBIT**



**MOOSE**



**WEASEL**

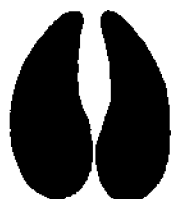

**WOLVERINE**

# ANSWER KEY—Animal Print Identification worksheet

Match the picture of each hind foot print with the name of the correct animal.



**WOLF**

**MOUSE**

**RABBIT**

**MOOSE**

**WEASEL**

**WOLVERINE**

Prints of white-footed mouse, actual size

front



hind



track pattern in snow—  
mark of tail often seen



---

Prints of cottontail rabbit, actual size

front



hind

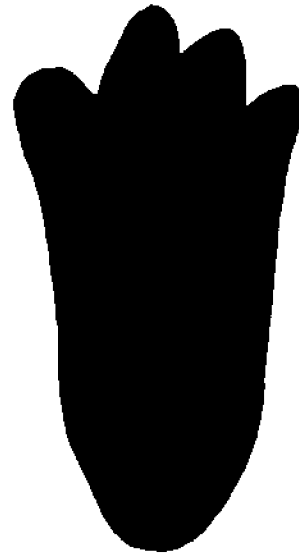

track pattern in snow

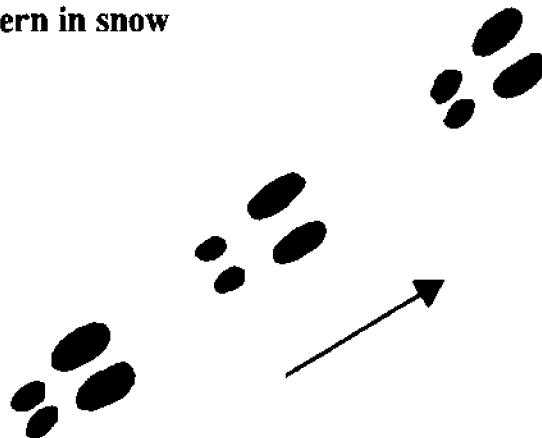

Prints of weasel, actual size

front



hind



track pattern in snow—  
mark of belly often seen

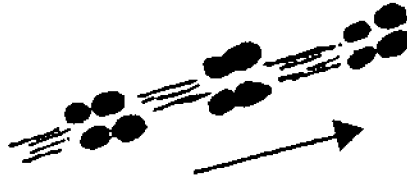

---

Prints of wolf, actual size

front and hind



track pattern in snow

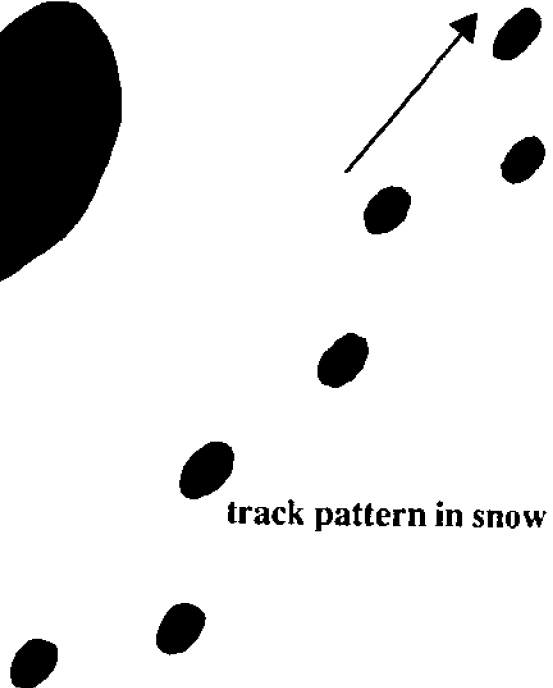

Prints of wolverine, actual size

front



track pattern in snow

hind



Prints of moose, actual size

front and hind

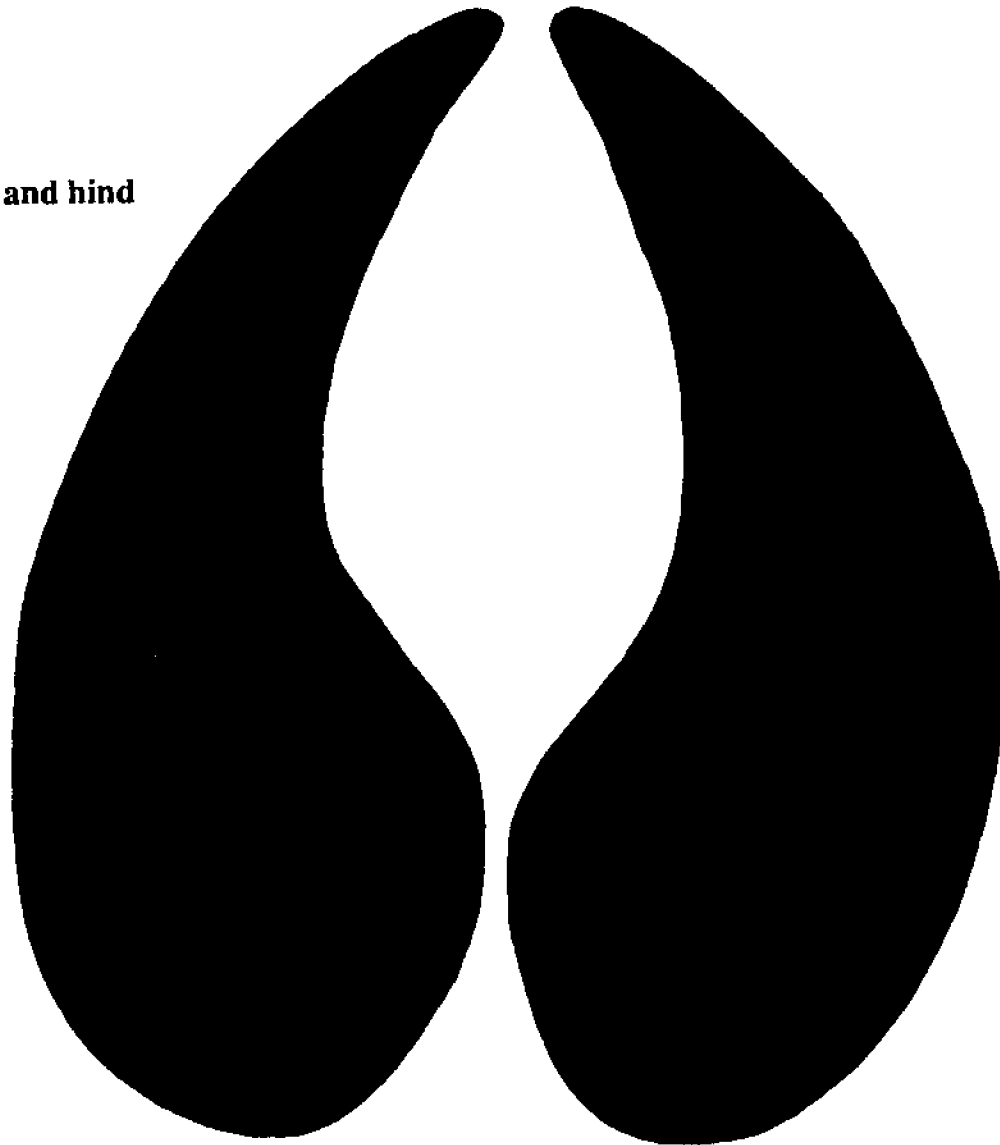

track patterns in snow—  
note marks where toes drag

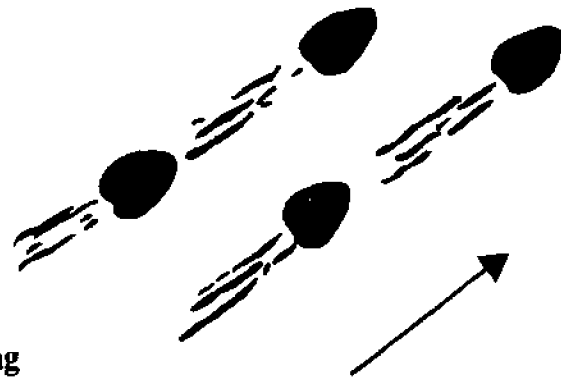

Sample track picture story  
What happened here?





# Pond Diorama

---

## Background

Read Chapter 4, *Brook and Beaver Pond*, and discuss the following questions.

1. How did beavers make the pond? *They built a dam across the stream.*
2. What does the beavers' home look like? *It is made of sticks held together with mud. It looks like a small island in the pond.*
3. What do the pond banks look like? *There are many trees around the pond. There are stumps of trees that the beavers have cut down.*
4. What animals are mentioned in the chapter? *Beavers, deer, mink, fish, muskrat, skunk, porcupine.*
5. Why would these animals need the pond? *For food and water (all), for a home or protection from enemies (beaver, fish, muskrat).*

## Objectives

When they have completed this activity, students will be able to name animals that live in or near a northern pond and tell how those animals use the pond.

## Materials

Large shoe box or small carton for each diorama (have each student make one, or collaborate on a larger one for the whole class), pictures of pond animals (cut from magazines or draw your own), stiff paper or oaktag, paste, plain wood toothpicks or small twigs, modelling clay, tempera paints and brushes, aluminum foil and cotton balls (optional).

## Terms to Know

**Diorama**—a three-dimensional picture or scene

**Lodge**—a beaver's home, built of sticks and mud in a pond

## Procedure

1. Set the shoe box on one long side, opening toward you. The two short sides and the bottom of the box form three "walls" of your diorama. The two long sides become the "ground" and the "sky." See the diagram on the next page.
2. Use tempera paints to paint the background scene on the "walls" of the diorama. Remember that this pond is in a forested area and that beavers have cut down some trees.
3. Paint the sky on the diorama. You may want to glue on cotton balls to make clouds.

4. Paint the ground and the pond on the diorama. You may want to use a piece of aluminum foil to represent the water in the pond.
5. Make the beavers' dam and home (lodge). Use pieces of toothpicks or twigs for the sticks. Use modelling clay to "glue" the sticks together. Position the dam along one side of the pond and the lodge in the center of the pond. Use more clay to hold them in place. You may want to use pieces of twigs stuck in clay along the edges of the pond to represent the stumps of cut trees.
6. Cut from magazines or draw your own pictures of the pond animals. Cut out each animal and paste it to a piece of stiff paper, leaving a tab of stiff paper at the bottom (see the diagram below). Position the animals in the diorama by folding the tab underneath and gluing it to the box; the animals will stand up. Your diorama is complete!

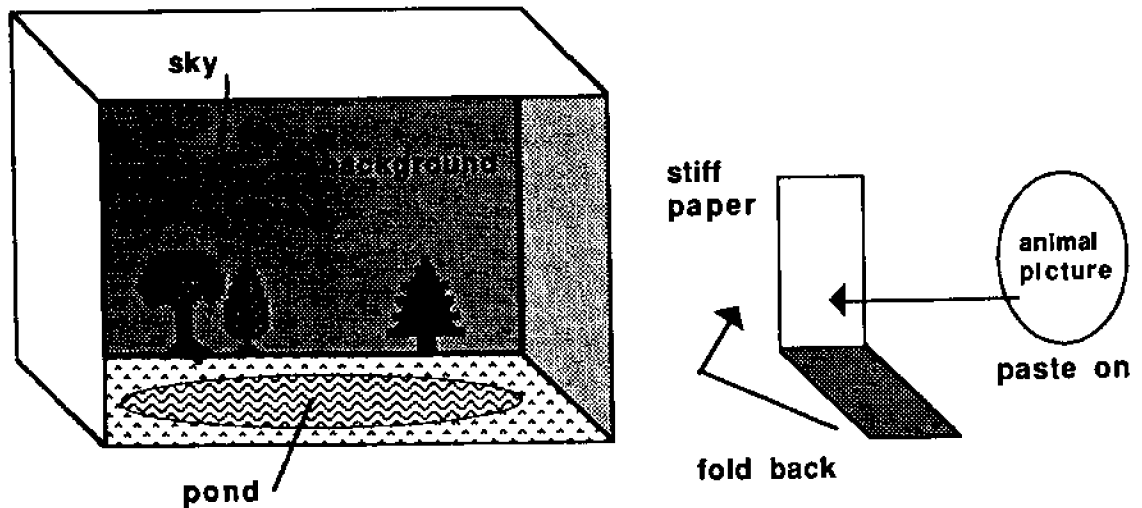

**Diorama**

---

# Beaver's Point of View

---

## Introduction

Paddle travelled down the brook and into a beaver pond. The author describes all the things Paddle “sees.” He is writing from Paddle’s point of view. In the middle of the pond, an old beaver sits on top of his lodge. What might the beaver think of Paddle? What might he think of the other animals at the pond? How might he feel as he scratches himself in the sun? The old beaver has a different point of view than Paddle does. Different things are important to him.

## Objectives

When the students have completed this activity, they will be able to list the six basic questions a story should answer. They will write and illustrate a story which answers these basic questions.

## Materials

Paper, pencil or pen, markers or crayons.

## Procedure

1. Discuss with students what they expect to find out when they read any story. Six basic questions should be mentioned:
  - \* **WHO** is the story about?
  - \* **WHAT** is happening in the story?
  - \* **WHY** do these things happen?
  - \* **WHEN** is it happening?
  - \* **WHERE** does the story take place?
  - \* **HOW** is the problem solved? (How does the story end?)
2. Read Chapter 4, *Brook and Beaver Pond*. Discuss what the old beaver sees from the top of his lodge and how the beaver might feel about Paddle and the other animals. Try to answer the six basic questions from the beaver’s point of view as you talk about the chapter.
3. Pretend you are the old beaver and write a story about the pond from his point of view. Remember the six questions your story should answer.
4. Draw a picture to illustrate your story. What basic question(s) have you answered with your drawing?

## Extension Activities

Choose another animal mentioned in the chapter and write a story from its point of view. OR write a play about the pond and give a speaking part to each of the animals.

---

# Forest Careers

---

## Introduction

As Paddle floated down the river during the first Spring of his voyage, he was caught in a log jam and carried toward a sawmill. The logs had been piled along the river banks by loggers, or lumberjacks. The lumberjacks cut the trees in forested areas and sent them off to the sawmill. There are many careers related to growing, harvesting, and using forests and trees.

## Objective

When students have completed this activity, they will be able to list and describe at least three forest-related careers.

## Materials

Forest Careers worksheet (master on page 50), pencil or pen.

## Procedure

1. Ask students to think of jobs related to forests or trees. For each job named, list at least one responsibility involved in that job. For example, a logger cuts down trees. A list of some **Forest-Related Careers** is on the following page. Did the class think of all of these? Did you come up with any different ones?
2. Find out about forest-related jobs in your community or state. This information would be available from area colleges or universities, Cooperative Extension services, Chambers of Commerce, or industries. Check your local telephone directory for phone numbers and addresses. Call or write to request information about different forest careers. If you choose to write, use the suggestions for requesting information and the business letter format found on page 21. Make a bulletin board to display your information.
3. Invite a representative of one of the agencies you contacted to speak to the class about his/her job and related careers. Before the speaker arrives, think of questions to ask or issues you want to talk about and encourage students to interview the speaker. Encourage the speaker to bring informational handouts or ideas for activities to do with the class that could enhance the speaker's presentation.
4. Complete the **Forest Careers** worksheet.

## Examples of Forest-related Careers

**Arboretum employee**—classifies and cares for woody plants including trees; may preserve samples for display.

**Botanist**—studies the life cycles, growth, structure, and classification of plants.

**Forester**—studies the growth patterns, management, and use of wooded areas; helps decide what trees should be planted to fulfill a given need (for lumber or to enhance wildlife habitat, for example).

**Landscaper**—plans where trees and other plants should be placed to fulfill specific functions (for decoration or to attract wildlife, for example).

**Logger**—cuts down trees and prepares logs for transportation to mills.

**Lumberyard employee**—sorts and stacks types of lumber for different uses.

**Paper mill employee**—performs any of a number of functions involved in transforming wood chips into paper.

**Park naturalist**—communicates information about the growth and use of forests and natural areas to the people who visit the park.

**Research scientist**—discovers new ways to use wood or wood products; studies how trees affect the environment and how they are affected by the environment.

**Sawmill operator**—processes logs into different types of lumber.

**Tree farm operator**—grows trees for sale, for example to landscapers or to Christmas tree suppliers.

**Tree surgeon**—cares for trees; studies diseases of trees and how to cure them; cuts down dead branches or trees.

**Truck driver**—carries logs, trees and plants, or wood products from one place to another.

**Wood products marketer**—chooses and sells things made from wood to businesses and the general public (paper or furniture, for example).

NAME \_\_\_\_\_

## Forest Careers worksheet

Read the job descriptions listed below. Then choose the career name that best applies to the description and write the letter of the career name in the space provided.

- \_\_\_\_\_ Designs a display to explain how wooded areas in a park are used by people and animals.
- \_\_\_\_\_ Decides what trees should be planted to provide the best supply of lumber for building materials.
- \_\_\_\_\_ Cuts down trees in wooded areas and prepares logs for transportation to sawmills.
- \_\_\_\_\_ Cuts logs into lumber for different uses.
- \_\_\_\_\_ Selects trees and shrubs to plant near a house to attract birds to the area.
- \_\_\_\_\_ Processes wood chips into newsprint for a newspaper publisher.
- \_\_\_\_\_ Studies diseases of trees and cuts down dead branches.

- A. Forester
- B. Logger
- C. Landscaper
- D. Naturalist
- E. Paper mill employee
- F. Sawmill operator
- G. Tree surgeon

## ANSWER KEY—Forest Careers worksheet

Read the job descriptions listed below. Then choose the career name that best applies to the description and write the letter of the career name in the space provided.

- D     Designs a display to explain how wooded areas in a park are used by people and animals.
- A     Decides what trees should be planted to provide the best supply of lumber for building materials.
- B     Cuts down trees in wooded areas and prepares logs for transportation to sawmills.
- F     Cuts logs into lumber for different uses.
- C     Selects trees and shrubs to plant near a house to attract birds to the area.
- E     Processes wood chips into newsprint for a newspaper publisher.
- G     Studies diseases of trees and cuts down dead branches.

- A. Forester
- B. Logger
- C. Landscaper
- D. Naturalist
- E. Paper mill employee
- F. Sawmill operator
- G. Tree surgeon

---

# Uses of Trees

---

## **Introduction**

A lumberjack saved Paddle from the saw at the sawmill. But the log that had carried Paddle went on through the sawmill and was made into lumber. Many other products come from trees as well.

## **Objectives**

When students have completed this activity, they will be able to list at least five products that they use in their daily lives that come from trees. They will be able to give examples of at least three different categories of products from trees.

## **Materials**

Uses of Trees list (master on page 53).

## **Procedure**

1. Ask students to think of as many products from trees as they can. Products from trees include all kinds of wood products, paper, and food items, among other things. How do students use these products in their daily lives?
2. How did American Indians use trees? The Chippewa were expert at building canoes from birchbark (build your own model birchbark canoe using the directions on pages 110 through 112). They also made baskets and built homes from wood and bark. Dyes from bark, roots, and fruits were used to color clothing and crafts. Trees provided food as well.
3. Study the Uses of Trees list. How many of the uses shown here did you think of? Did you think of any that are not on this list? What uses seem unusual to you?
4. Make a bulletin board or set up a display table to illustrate different uses of trees. Have students bring in examples or pictures of products from trees. Draw pictures showing products from trees and how people use them. Make labels for different products and/or different categories of products (building materials, furniture, food, etc.).
5. Play an alphabet game with products from trees. Try to think of products that begin with each letter of the alphabet (A for apple, B for boat, C for charcoal, etc.). How many of these are represented on your bulletin board or display table? You may want to consult an encyclopedia for more information about the uses of trees.



# Uses of Trees

## Wood Products

**Airplanes**  
**Barrels**  
**Baseball bats**  
**Baskets**  
**Boats**  
**Bowling pins**  
**Boxes**  
**Bridges**  
**Building materials**  
**Cabinets**  
**Caskets**

**Charcoal:**  
Explosives  
Filters  
Fuel

**Crates**  
**Doors**  
**Fenceposts**  
**Flooring**  
**Foundations**  
**Furniture**  
**Matches**  
**Mine timbers**  
**Musical instruments**  
**Paneling**  
**Pencils**  
**Plywood**  
**Railroad ties**

**Sawmill wastes:**  
Bedding for animals  
Fuel (wood alcohol)  
Insulation board  
Packing materials  
Particle board  
Pulp chips

**Shingles**  
**Signs**  
**Telephone poles**  
**Tongue depressors**  
**Toothpicks**  
**Toys**  
**Veneer**  
**Window frames**

**Wood pulp:**  
Acetate  
Cardboard  
Cellophane  
Paper  
Photographic film  
Plastics  
Rayon (fabric)

## Other Forest Products

**Bark:**  
Adhesives  
Cork  
Dyes  
Fuel  
Soil mulch  
Tannic acid

**Fruit:**  
Apples  
Beechnuts  
Black walnuts  
Blueberries  
Cranberries  
Hickory nuts  
Oranges  
Pecans  
Pine nuts

**Gum:**  
Pine oil  
Rosin  
Turpentine  
Varnish

**Leaves:**  
Cedar oil  
Holly  
Wreaths

**Sap:**  
Maple sugar  
Maple syrup

---

# Logs to Lumber

---

## Introduction

How does a log become lumber? Read Chapter 7, *Paddle Meets a Friend*. Look at the diagram of the sawmill at the top of that page. The boom keeps other logs together in the water until they are pushed onto the bull-chain. Then the logs are carried through the saws and cut into boards. Finished lumber and the leftover sawdust are shipped to lumberyards or factories to be made into other products.

## Objective

When students have completed this activity, they will be able to name and define terms related to sawmills and lumber.

## Materials

**Sawmill Terms** crossword puzzle (master on page 55), pencil or pen.

## Terms to Know

**Boom**—barrier or fence made of logs attached end-to-end to keep loose logs together in the water

**Bull-chain**—chain with spikes that carries logs through the runway

**Carriage**—moving platform that supports and shifts logs in the sawmill

**Chute**—tube or trough where waste materials are dropped

**Lath**—narrow strip of wood

**Logs**—trunks of trees that have been cut down and had their branches removed

**Lumber**—logs that have been sawed into boards

**Plane**—to make smooth or level

**Runway**—channel in which logs move

**Season**—to age wood to improve its durability

**Slab**—flat, broad, thick piece of wood

**Tram**—open railway car

## Procedure

1. Study Holling's diagram of a sawmill. Find the vocabulary words on the diagram. Can you figure out what each is by looking at this picture?
2. Complete the **Sawmill Terms** crossword puzzle. All the words used are found in Chapter 7.
3. Why do you think the sawmill in the story is close to water? What other ways are there to carry logs to sawmills or to carry lumber from sawmills? Discuss what things you would need to run a successful sawmill.

NAME \_\_\_\_\_

## Sawmill Terms crossword puzzle

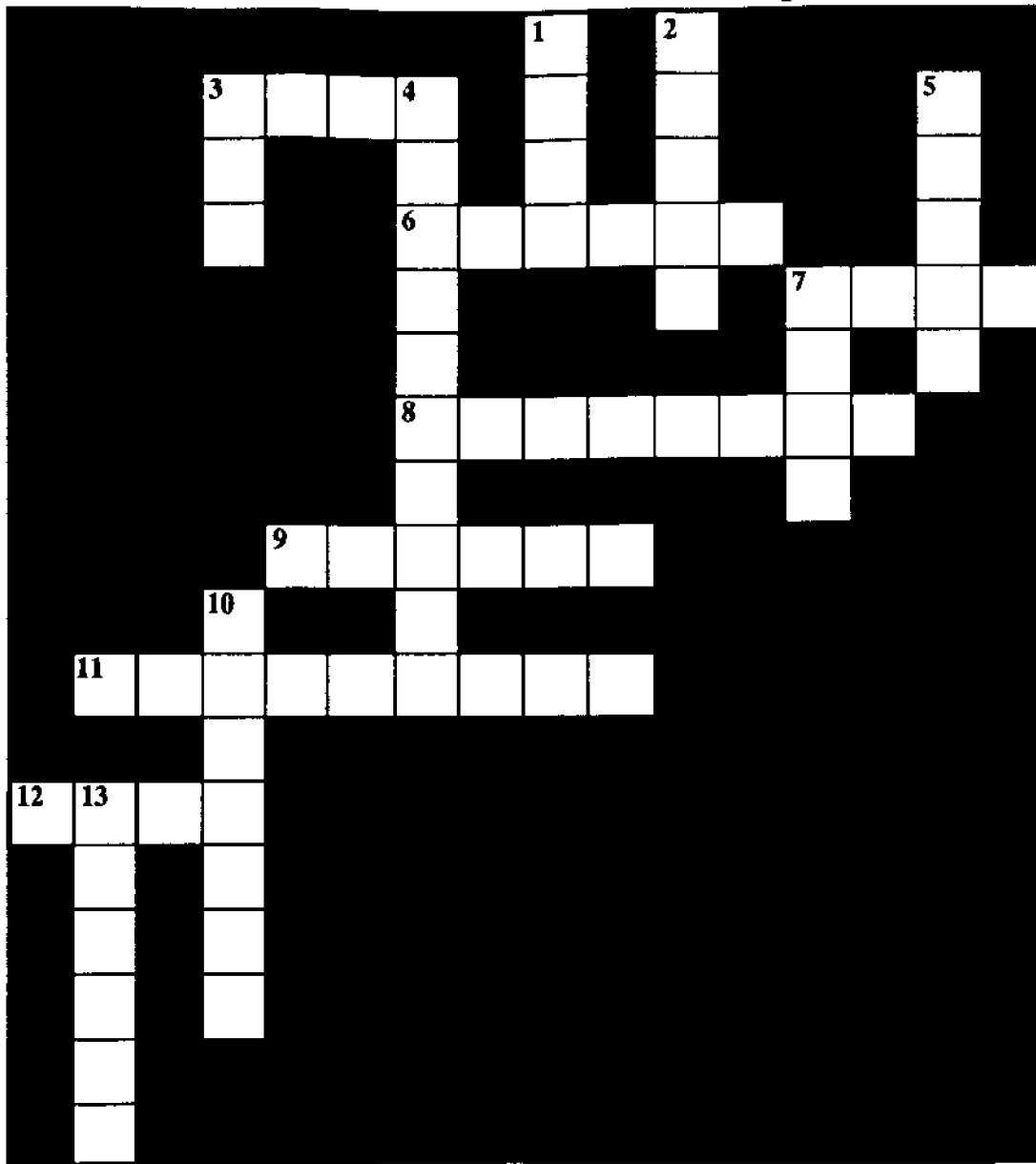

### ACROSS CLUES

3. Flat, broad, thick piece of wood
6. Logs sawed into boards
7. Narrow strip of wood
8. Moving platform that supports or shifts wood
9. Made smooth or level
11. Aging wood to improve its durability
12. Open railway car

### DOWN CLUES

1. Barrier or fence of connected logs
2. Stacked
3. Cutting tool
4. Spiked chain used to move logs in the runway (hyphenated word)
5. Trough down which wastes are dropped
7. Tree trunks from which the branches have been removed
10. Factory where logs are sawed
13. Channel or track in which logs move

## ANSWER KEY—Sawmill Terms crossword puzzle

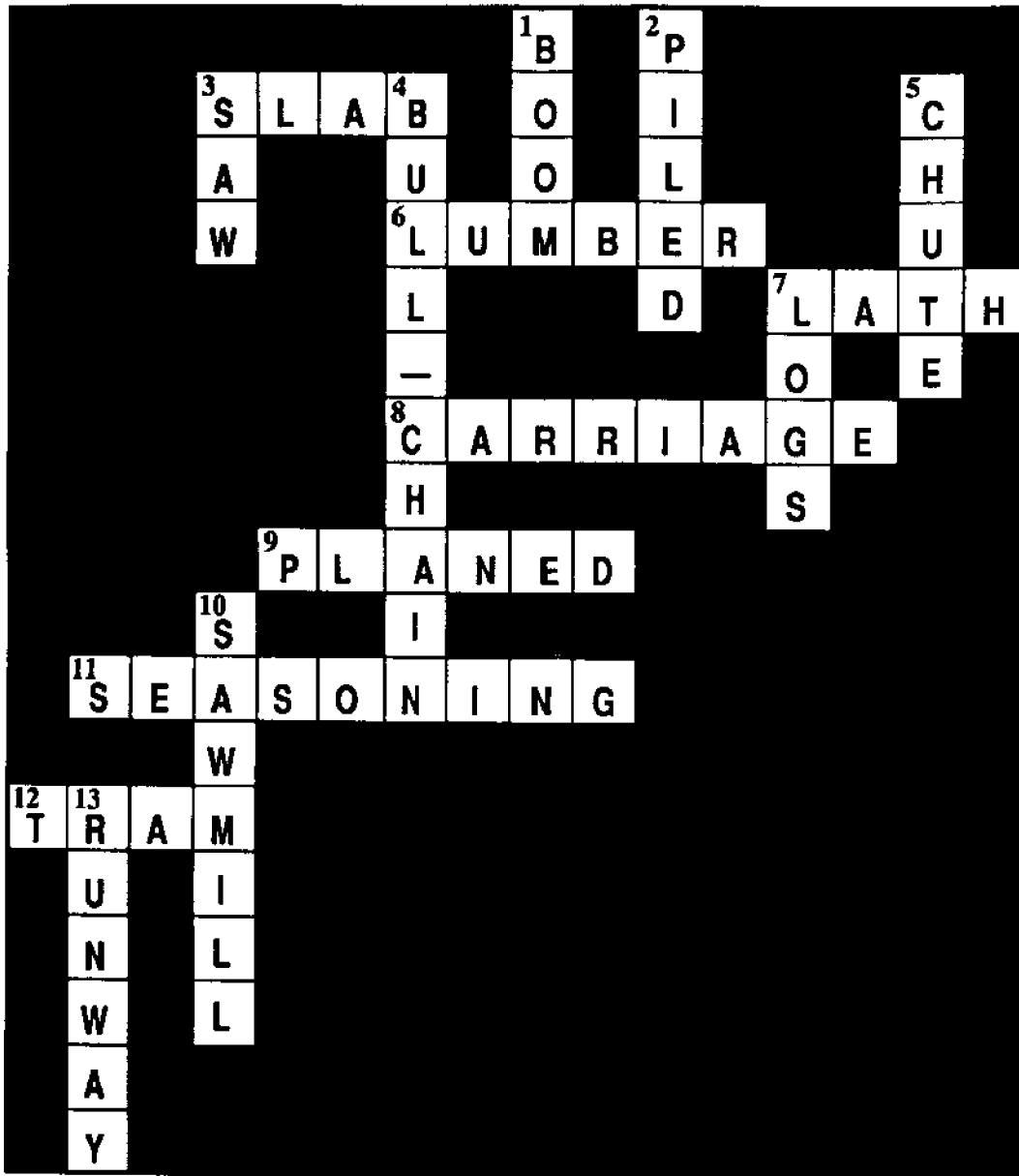

**Word List:**  
 BOOM  
 BULL-CHAIN  
 CARRIAGE  
 CHUTE  
 LATH  
 LOGS  
 LUMBER  
 PILED  
 PLANED  
 RUNWAY  
 SAW  
 SAWMILL  
 SEASONING  
 SLAB  
 TRAM

### ACROSS CLUES

3. Flat, broad, thick piece of wood
6. Logs sawed into boards
7. Narrow strip of wood
8. Moving platform that supports or shifts wood
9. Made smooth or level
11. Aging wood to improve its durability
12. Open railway car

### DOWN CLUES

1. Barrier or fence of connected logs
2. Stacked
3. Cutting tool
4. Spiked chain used to move logs in the runway (hyphenated word)
5. Trough down which wastes are dropped
7. Tree trunks from which the branches have been removed
10. Factory where logs are sawed
13. Channel or track in which logs move

---

# How Waves Move

Adapted from OEAGLS EP-027, *Waves on the Great Lakes*

---

## Introduction

As Paddle travelled through the Great Lakes, he was constantly moving through the water. He rode forward on currents, was pushed backward by wind, and bobbed up and down on the waves. This activity will help you find out how objects move in water waves.

## Objectives

When students have completed this activity, they will be able to identify the parts of a wave and to describe the motion of an object in a wave.

## Materials

Length of rope (at least three meters), masking or duct tape, **Parts of a Wave** diagram and **How Waves Move** worksheet (masters on pages 58-59).

## Terms to Know

**Crest**—the highest point on a wave

**Trough** (pronounced *troff*)—the lowest point on a wave

**Wave height**—the vertical (up and down) distance between the crest and trough of a wave

**Wavelength**—the distance from the crest of one wave to the crest of the next

## Procedure

1. Discuss some of the things you have seen which cause waves to form on water. What kind of motion have you observed in waves? What do you think causes most waves? (*Wind is the most common cause of waves on water.*)
2. Make a transparency of the **Parts of a Wave** diagram. Indicate the crest, trough, wave height, and wavelength in turn and ask students to define these terms in their own words. Discuss the definitions given in **Terms to Know**.
3. Explain that waves move objects up and down, but not forward. When objects move forward in water, they are carried by currents or pushed by wind. Waves by themselves make objects move up and down.
4. Use the rope to demonstrate how objects move in a wave. Wrap a piece of tape around the middle of the rope, then secure one end. Shake the other end of the rope up and down to produce waves along its length. Look for crests, troughs, wave height and wavelength. How does the tape move? Which moves forward, the rope or the wave? How would you describe the motion of the rope as the wave passes through it?
5. Complete the worksheet, **How Waves Move**.

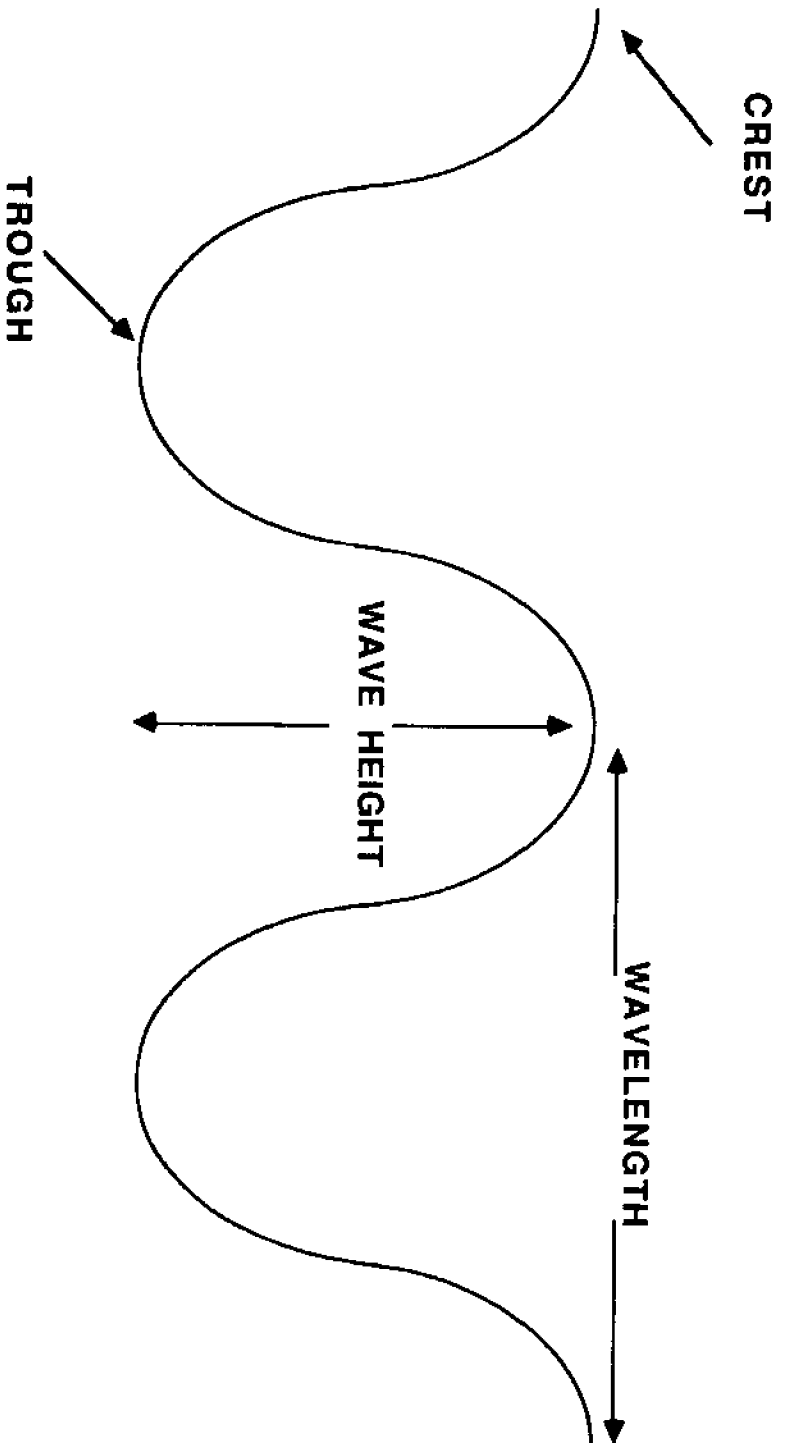

**Parts of a Wave diagram**

NAME \_\_\_\_\_

## How Waves Move worksheet

1. Name at least two things that cause waves to form on water. \_\_\_\_\_

\_\_\_\_\_

\_\_\_\_\_

2. What is the most common cause of waves on water? \_\_\_\_\_

\_\_\_\_\_

3. In the space below, draw a diagram of at least two complete waves.

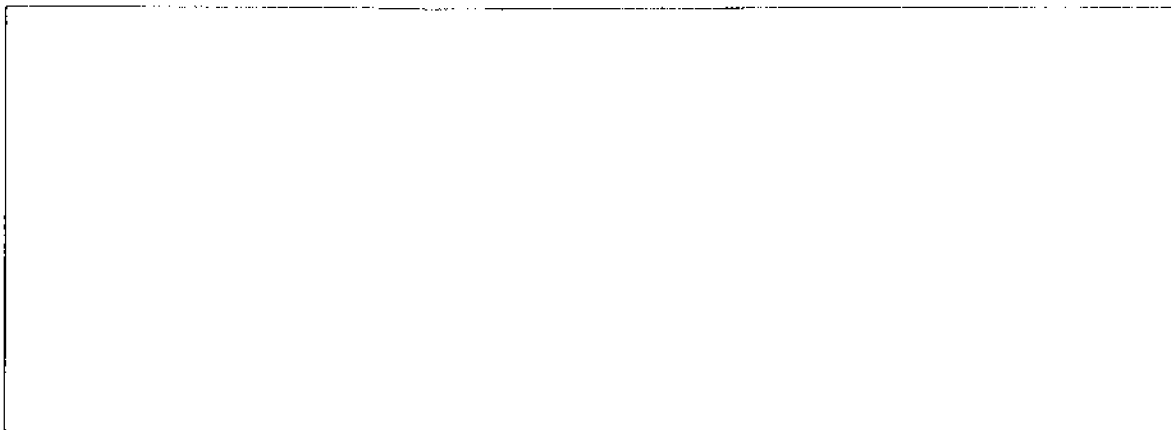

4. Label the **crest** of a wave on your diagram.

5. Label the **trough** of a wave.

6. Label the **wave height**.

7. Label the **wavelength**.

8. When you make waves in a rope, which moves forward, the rope or the wave?

\_\_\_\_\_

9. How does the rope move as waves pass through it? \_\_\_\_\_

\_\_\_\_\_

10. How does an object move in water when a wave passes by? \_\_\_\_\_

\_\_\_\_\_

11. If waves make an object move up and down in the water, what makes objects move forward? \_\_\_\_\_

## ANSWER KEY—How Waves Move worksheet

1. Name at least two things which cause waves to form on water. \_\_\_\_\_

*Wind, boats, fish jumping—any disturbance of the water's surface.*

2. What is the most common cause of waves on water? *Wind.*

3. In the space below, draw a diagram of at least two complete waves.

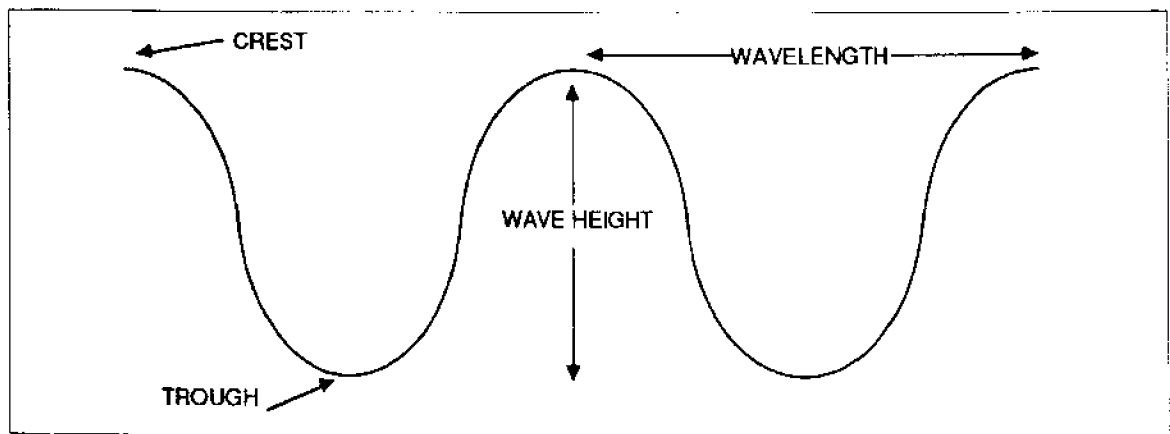

4. Label the **crest** of a wave on your diagram.  
5. Label the **trough** of a wave.  
6. Label the **wave height**.  
7. Label the **wavelength**.  
8. When you make waves in a rope, which moves forward, the rope or the wave?

*The wave moves forward through the rope.*

9. How does the rope move as waves pass through it? *Up and down.*

10. How does an object move in water when a wave passes by? *Up and down*

*like the tape moves up and down on the rope.*

11. If waves make an object move up and down in the water, what makes objects move forward? *Wind and currents carry objects forward.*



---

# Passport to Adventure

---

## Introduction

As Paddle travelled through the Great Lakes, he crossed the international border between Canada and the United States. In most cases, people need passports issued by their governments in order to travel in foreign countries. Some countries issue visas—formal permissions to enter or leave their borders—to travellers. Unlike people, animals, water, and air do not recognize national boundaries. They do not require passports, yet as they travel, they carry resources and pollutants from one country to another.

## Objectives

When students have completed this activity, they will be able to explain how passports and visas are used in international travel.

## Materials

Sample **Passport application** and **Passport booklet** (masters on pages 63-65), markers or crayons, pencil or pen, inkpads and objects to use for stamps, **Passport Language** crossword puzzle (master on page 66).

## Terms to Know

- Bearer**—the person who owns the passport
- Expiration**—date after which a passport is no longer valid
- Minors**—children under 18 years of age
- Nationality**—the country of one's birth
- Occupation**—job or profession
- Race**—ethnic group
- Signature**—one's written name on a document
- Validate**—allow or make valid
- Visa**—formal permission to enter or leave a country

## NOTE

Advance preparation is needed. Fill out passport applications, make passports, and decide on borders for “countries” ahead of time.

## Procedure

1. Fill out passport applications. Discuss any terms that are unfamiliar to you. Why would a government request this information before issuing a passport? Has anyone in the class ever travelled to a foreign country before?
2. Put together the passport booklets. Cut the pages apart along the dotted lines. Design a seal for your “country” to decorate the cover. Glue a picture of yourself in the space indicated (use a photograph or draw a self-portrait). Fasten the pages together along the left edge in numerical order inside the cover.

3. Decide where the borders for at least three “countries” will be. These can be areas within the classroom or different rooms in the school. You may want to ask other teachers or school personnel to participate. The library, gym, and art room could become different countries.
4. Assign at least two customs officials for each country. These people are in charge of stamping entry and exit visas on the passports of the “travellers.” The customs officials will need inkpads and stamps. Each country should have a different stamp. Use commercial rubber stamps, small blocks of wood, pieces of sponge or other objects. Customs officials should also write the date and time of entry or exit under the stamp imprint on each passport.
5. Assign a native country to all participants. Make sure everyone has a passport, then begin the travels! Student travellers should be sure to have passports stamped whenever they enter or leave a country. If they are taking anything from one country to another, they must declare this to customs officials as they leave the country. Have students travel to at least two other countries before returning to their native land. After everyone has returned “home,” discuss the experiences. What souvenirs were brought back from the travels?
6. Complete the **Passport Language** crossword puzzle to reinforce vocabulary words.

# Passport Application

FILL OUT THIS APPLICATION COMPLETELY AND CORRECTLY

Name \_\_\_\_\_  
Last First Middle Initial

Address \_\_\_\_\_  
Number and Street

\_\_\_\_\_ City State Zip Code

Telephone \_\_\_\_\_ / \_\_\_\_\_ - \_\_\_\_\_

Birthplace \_\_\_\_\_  
City State Country

Birthdate \_\_\_\_\_  
Month/Day/Year

Sex \_\_\_\_\_  
Male/Female

Height \_\_\_\_\_ meters \_\_\_\_\_ centimeters

Weight \_\_\_\_\_

Hair Color \_\_\_\_\_

Eye Color \_\_\_\_\_

Occupation \_\_\_\_\_

## PERSON TO CONTACT IN CASE OF EMERGENCY:

Name \_\_\_\_\_

Address \_\_\_\_\_

Telephone Home \_\_\_\_\_ / \_\_\_\_\_ - \_\_\_\_\_ Work \_\_\_\_\_ / \_\_\_\_\_ - \_\_\_\_\_

Relationship \_\_\_\_\_

I certify the above information to be correct to the best of my knowledge.

SIGNATURE OF APPLICANT \_\_\_\_\_



**WARNING:** Alteration, addition, or mutilation of entries is prohibited. Any unofficial change will render this passport invalid.

Name \_\_\_\_\_

Birthdate \_\_\_\_\_

Birthplace \_\_\_\_\_

Height \_\_\_\_\_ meters \_\_\_\_\_ centimeters

Hair color \_\_\_\_\_

Eye color \_\_\_\_\_

Issue Date \_\_\_\_\_

1

EXPIRATION DATE \_\_\_\_\_

\_\_\_\_\_  
SIGNATURE OF BEARER

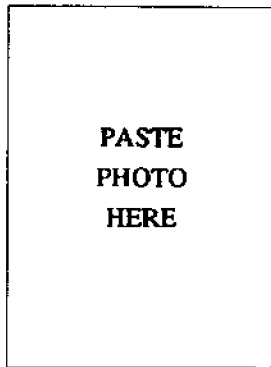

PASSPORT NUMBER \_\_\_\_\_

Bearer's home address

\_\_\_\_\_  
Number and Street

\_\_\_\_\_  
City State

\_\_\_\_\_  
Zip Code

**IN CASE OF DEATH OR ACCIDENT,** notify the nearest diplomatic or consular office and:

Name \_\_\_\_\_

Address \_\_\_\_\_

Telephone \_\_\_\_\_ / \_\_\_\_\_ - \_\_\_\_\_

2

3

**VISAS**

Entries

Exits

**VISAS**

Entries

Exits

4

5

**VISAS**

Entries

Exits

6

NAME \_\_\_\_\_

## Passport Language Crossword Puzzle

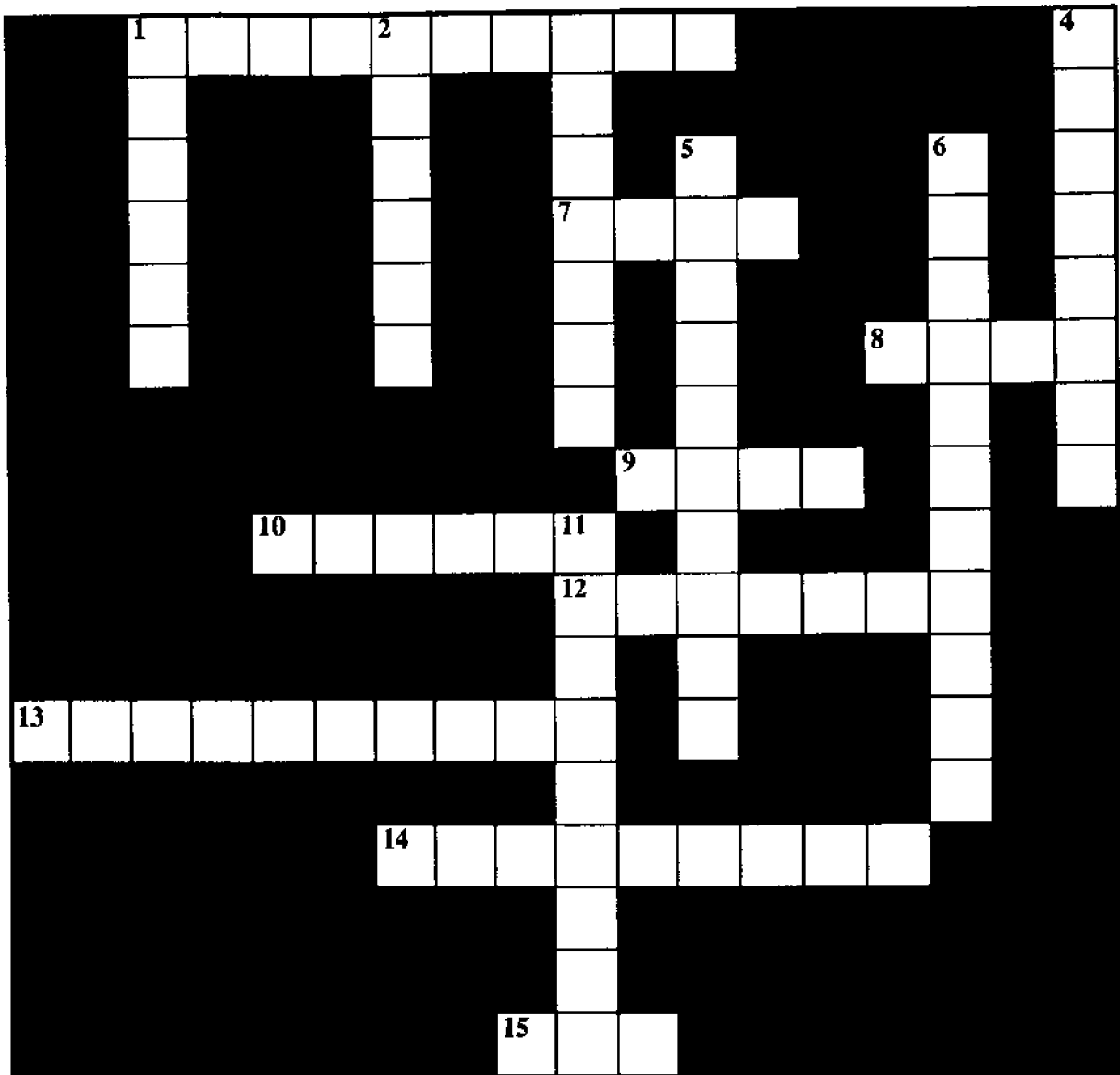

### ACROSS CLUES

1. The city, state, and country of one's birth.
7. Ethnic group.
8. Formal permission to enter or leave a country.
10. Children under 18 years of age.
12. Letter beginning a name.
13. Date after which a passport is no longer valid.
14. Month, day, and year of one's birth.
15. Male or female.

### DOWN CLUES

1. The person who owns the passport.
2. How tall a person is.
3. Where a person lives.
4. Allow or make valid.
5. One's job or profession.
6. The country of one's birth.
11. One's written name on a document.

# ANSWER KEY—Passport Language crossword puzzle

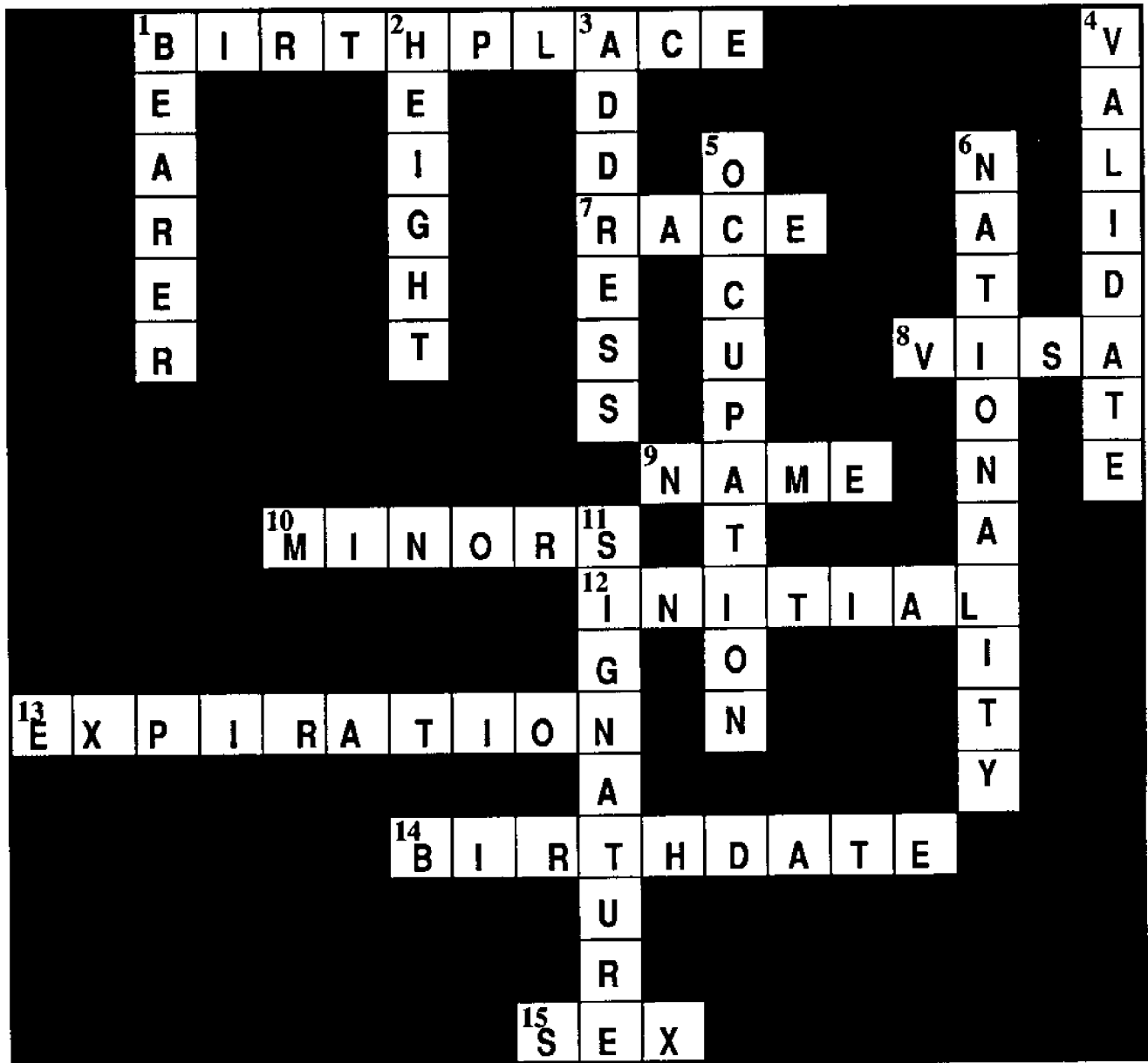

## ACROSS CLUES

1. The city, state, and country of one's birth.
7. Ethnic group.
8. Formal permission to enter or leave a country.
10. Children under 18 years of age.
12. Letter beginning a name.
13. Date after which a passport is no longer valid.
14. Month, day, and year of one's birth.
15. Male or female.

## DOWN CLUES

1. The person who owns the passport.
2. How tall a person is.
3. Where a person lives.
4. Allow or make valid.
5. One's job or profession.
6. The country of one's birth.
11. One's written name on a document.

## WORD LIST:

ADDRESS	NAME
BEARER	NATIONALITY
BIRTHPLACE	OCCUPATION
BIRTHDATE	RACE
EXPIRATION	SEX
HEIGHT	SIGNATURE
INITIAL	VALIDATE
MINORS	VISA

---

# Energy Flow and Food Webs

---

## Introduction

While Paddle was in the beaver pond, a mink caught a fish. Later, Paddle met a moose feeding on water lilies in the marsh. The mink and the moose both found the food energy they needed to survive. The water lilies used the sun's energy to grow. We can draw a diagram that shows who eats what and where energy for life comes from.

## Objectives

When students have completed this activity, they will be able to define what food chains and food webs are, and to explain that the sun is the basic source of energy.

## Materials

**Energy Flow** background sheet and worksheet (masters on pages 69-71), drawing paper, markers or crayons.

## Terms to Know

**Food chain**—diagram of who eats what

**Food web**—several food chains connected together

**Organism**—living thing

**Producer**—organism that can make its own food (green plant)

**Consumer**—organism that can not make its own food

**Herbivore**—consumer that eats plants

**Carnivore**—consumer that eats other consumers

**Decomposer**—consumer that breaks down dead plants and animals

## Procedure

1. Read the background sheets. Discuss and give examples of each of the defined terms. Think of other possible food chains using the animals Paddle found in the beaver pond or the marsh.
2. Draw your own energy flow diagram. Remember that the sun is the source of the energy plants need to grow. Each diagram should have at least three food chains connected to make a food web within it. Try to think of food chains you might find in environments other than ponds or marshes.  
(*Example: Sun - Grass - Cow - Person*)
3. Complete the **Energy Flow** worksheet. Discuss the answers with the class.

## Extension Activity

Play the **Food Chain Tag** game described on page 73.



## Energy Flow background sheet

A chain is made of connected parts called links. The terms “food chain” and “food web” describe the paths of energy flow between plants and animals in a natural community. A **food chain** is a simple diagram of who eats what. Each plant and animal stands for a link of energy in a food chain. Several food chains connected together make up a **food web**.

The sun is the first source of energy. Green plants use the sun’s energy and nutrients in the soil to make their own food by the process of photosynthesis. Because green plants make their own food, they are called **producers**.

All other living things in a food chain are called **consumers** because they cannot make their own food. Consumers that eat plants to get their energy are called **herbivores**. Consumers that eat other consumers to get their energy are called **carnivores**, or meat-eaters.

**Decomposers**, usually bacteria or fungi, are a special group of consumers. They break down dead plants and animals, returning nutrients to the soil where they can be recycled by green plants.

Below is a diagram of the energy flow in a food chain you might find in a pond.

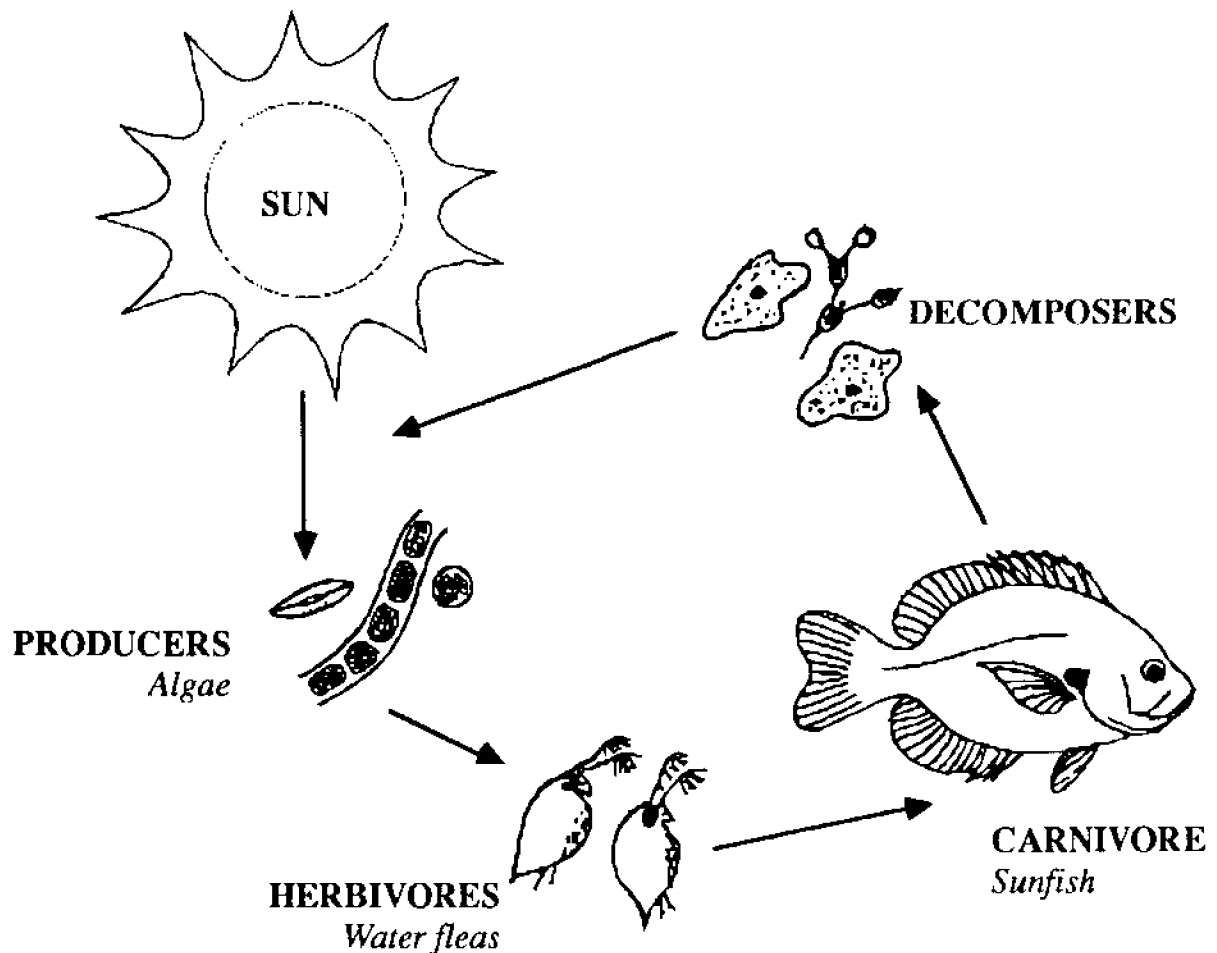

Here is a diagram of the energy flow in a pond food web. Can you identify the different food chains within the web?

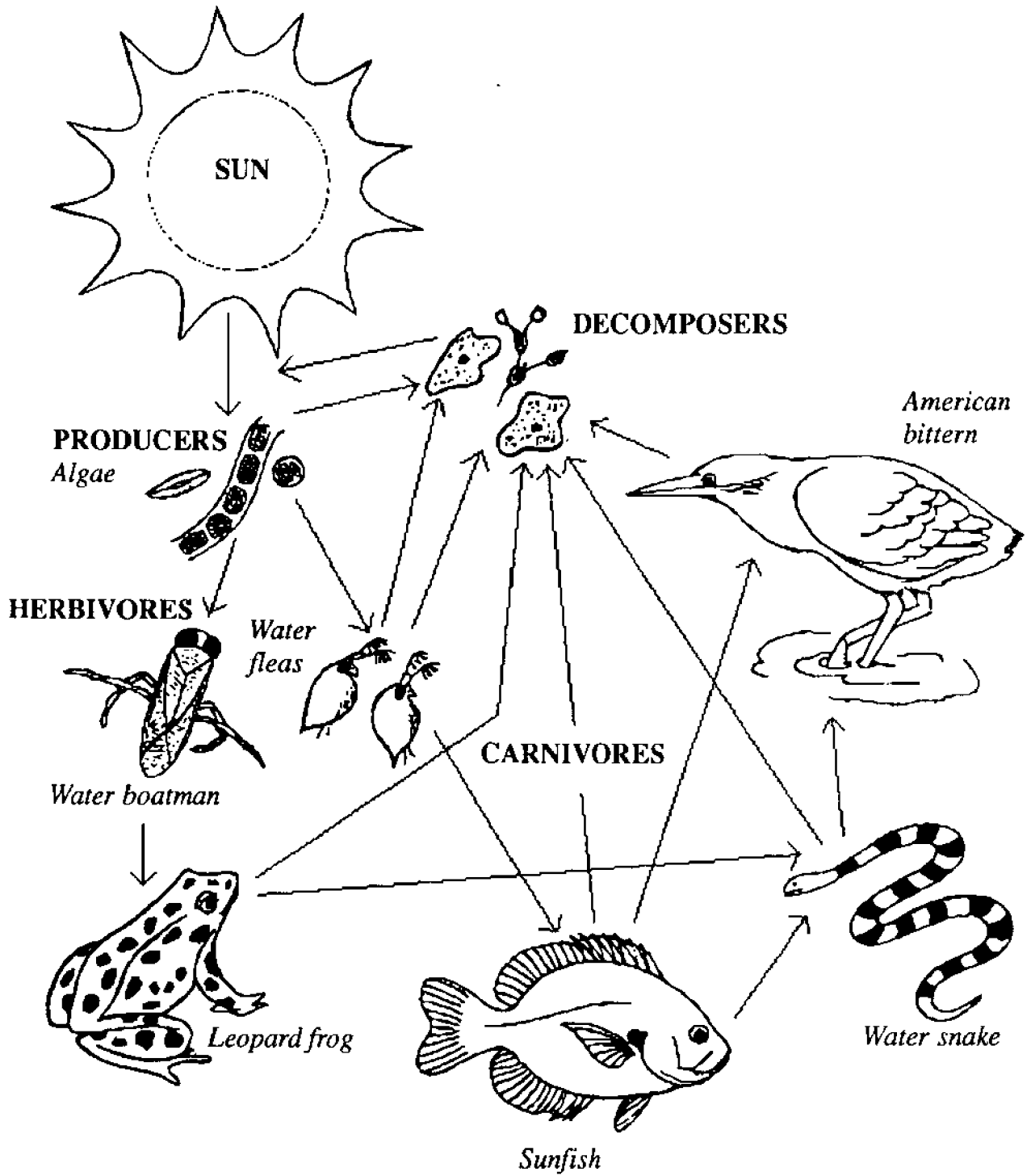

NAME \_\_\_\_\_

## Energy Flow worksheet

Answer the following questions.

1. What is a food chain? \_\_\_\_\_
2. What is a food web? \_\_\_\_\_
3. Where do green plants get the energy they need to grow? \_\_\_\_\_
4. What is a producer? \_\_\_\_\_  
Give an example. \_\_\_\_\_
5. What is a consumer? \_\_\_\_\_
6. What is a herbivore? \_\_\_\_\_  
Give an example. \_\_\_\_\_
7. What is a carnivore? \_\_\_\_\_  
Give an example. \_\_\_\_\_
8. What do decomposers do? \_\_\_\_\_

On the diagram below, label the **SUN**, a **PRODUCER**, a **HERBIVORE**, a **CARNIVORE**, and a **DECOMPOSER**. Trace over the lines showing the energy flow in **ONE** food chain.

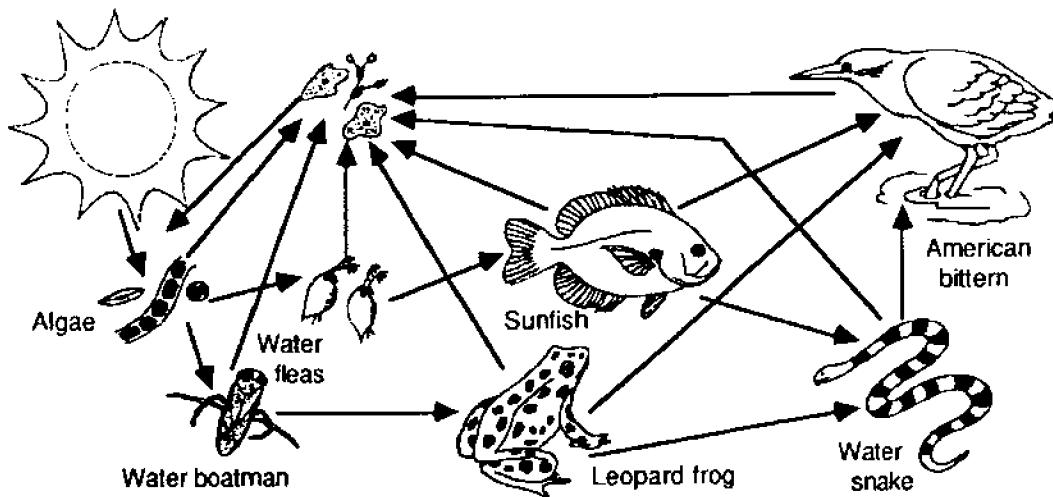

## ANSWER KEY—Energy Flow worksheet

Answer the following questions.

1. What is a food chain? A simple diagram of who eats what.
2. What is a food web? Many food chains connected together.
3. Where do green plants get the energy they need to grow? From the sun.
4. What is a producer? An organism which makes its own food (green plant).

Give an example. Algae is a producer shown in the pond food web. (Accept any green plant.)

5. What is a consumer? A living thing that can not make its own food.
6. What is a herbivore? A consumer that eats plants (producers).

Give an example. Water fleas and water boatman are shown. Also accept any animal that eats only plants (cows, rabbits, or deer, for example).

7. What is a carnivore? A consumer that eats other consumers.

Give an example. Accept any of the carnivores shown or any others (bears, dogs or cats, for example).

8. What do decomposers do? Break down dead plants and animals to recycle nutrients.

On the diagram below, label the SUN, a PRODUCER, a HERBIVORE, a CARNIVORE, and a DECOMPOSER. Trace over the lines showing the energy flow in ONE food chain (only one example is shown).

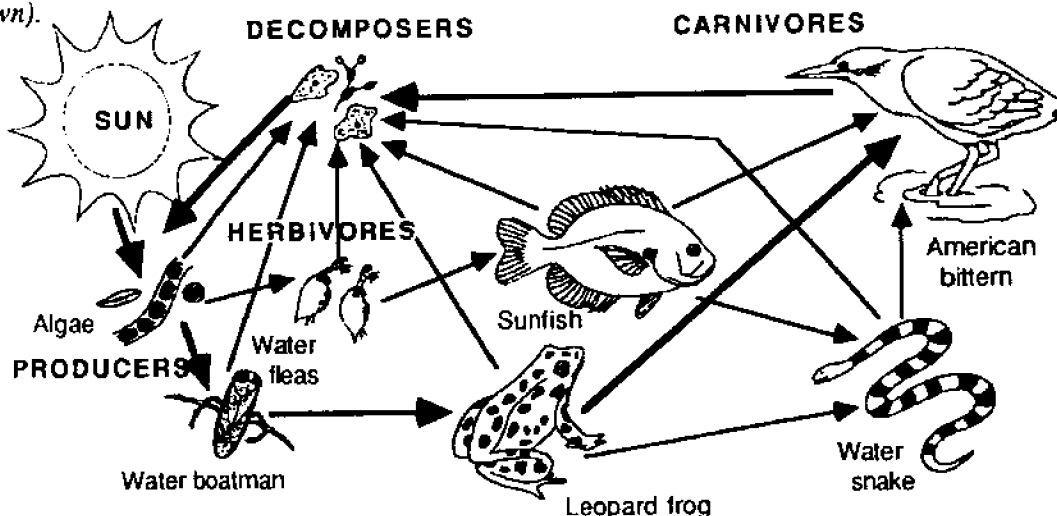

---

# Food Chain Tag

---

## Background and Discussion:

1. Read and discuss the **Energy Flow** background sheets (masters on pages 69-70) with your class.
2. Introduce the topic of poisons in the environment. Ask students to name some poisons they might have used or seen their parents use (examples are insecticides, weed killers, rat poison, etc.). Explain that creatures may be harmed by a poison intended for something else. An example is the insecticide DDT, which was found to harm fish and birds as well as insects and was outlawed in the United States and Canada because of this. Explain that even though a poison may not kill an animal immediately, it could make the animal too sick to be able to survive or reproduce.

## Objectives

When students have completed this activity, they will be able to describe how environmental poisons concentrate in a food chain.

## Materials

Small squares of paper (at least 150 squares for a class of 20-30 students), plastic sandwich bags (1 for each student), three colors of yarn.

## Preparation

1. Mark about 1/3 of the squares of paper with an X or a skull and crossbones. Fold all of the squares in half so the marked ones appear identical to the unmarked ones.
2. Divide the plastic bags into two groups of equal size. Divide **one** of those groups into thirds; separate one third from the other two. You now have three groups of different sizes.
3. Put a piece of yarn into each bag. Use a different color for each group. The colors will help players identify each other during the game.

## Procedure

1. Gather in a large open area, indoors or outside.
2. Give each student one of the plastic bags with yarn in it. The bags represent the "stomachs" of the animals in the food chain. The different colors of yarn help students identify each other during the game.
3. The largest group of students represents **WATER FLEAS**, the next largest group represents **SUNFISH** and the smallest group represents **BITTERN**. (These are animals mentioned in the pond food web. You may choose any other herbivore/carnivore combinations for your food chain.)

4. Scatter the folded pieces of paper over the ground. These represent the WATER FLEAS' food source; the marked pieces have been contaminated by a poison.
5. To begin the game, send all the WATER FLEAS to gather as many pieces of paper as they can. They must put the "food" into their "stomachs."
6. After about 30 seconds, send the SUNFISH to catch the WATER FLEAS. When a WATER FLEA is caught, he must give his "stomach" to the SUNFISH who will put it into his own "stomach." That WATER FLEA is then out of the game and must go to the sidelines. WATER FLEAS must continue to gather "food" while trying to avoid the SUNFISH.
7. After about another 30 seconds, send the BITTERNs to catch the SUNFISH. When a SUNFISH is caught, he must give his "stomach" to the BITTERN who will put it into his own stomach. That SUNFISH is then out of the game and must go to the sidelines. SUNFISH must continue to catch WATER FLEAS while avoiding the BITTERNs.

#### **NOTE**

The BITTERNs may catch only SUNFISH, the SUNFISH may catch only WATER FLEAS, and the WATER FLEAS must gather only "food."

8. After about a minute and a half, stop the game. Have everyone sit in a circle to discuss the results.
9. Find out how many of each group were "eaten" and how many escaped. Have those who escaped empty their "stomachs" and count the number of "poison" pieces of paper they have collected in all. Use the chart on the next page to find out how many of each group will "die" because of the amount of poison they have eaten and how many will not be able to reproduce successfully.
10. You can play additional rounds with those who survive (including those who could not reproduce) to see the further effects of poison concentrating in the food chain.

## Effects of Poison chart

ANIMAL	NUMBER OF POISON PAPERS IN "STOMACH"	STATUS
WATER FLEA	LESS THAN 3	SURVIVES
	3-4	SURVIVES BUT CAN NOT REPRODUCE
	MORE THAN 4	DIES
SUNFISH	LESS THAN 4	SURVIVES
	4-6	SURVIVES BUT CAN NOT REPRODUCE
	MORE THAN 6	DIES
BITTERN	LESS THAN 5	SURVIVES
	5-8	SURVIVES BUT CAN NOT REPRODUCE
	MORE THAN 8	DIES

---

# Travel Math

Adapted from OEAGLS EP-014, *Geography of the Great Lakes*

---

## Introduction

Paddle began his journey in a stream north of Lake Superior, then travelled through the Great Lakes and along the St. Lawrence River to the sea. His journey carried him around the **perimeter** of Lake Superior, and he travelled at different speeds depending upon the forces of currents and winds.

## Objectives

When students have completed this activity, they will be able to use basic math skills to determine perimeter and to solve distance, rate, and time problems.

## Materials

Pencil or pen, metric ruler, string, **Calculating Scale and Perimeter and Distance, Rate and Time** worksheets (masters on pages 77,78 and 81).

## Terms to Know

**Perimeter**—distance around the outside of an object

**Scale**—relationship of the size of an object in a picture or on a map to its size in real life

## Procedure

1. Complete the **Calculating Scale and Perimeter** worksheet.
2. Use string and a ruler to find the perimeter of different objects in the classroom. You might measure a textbook, a globe, a desktop, a pencil, or your foot.
3. Complete the **Distance, Rate, and Time** worksheet.

## Discussion Questions

1. When might you need to calculate perimeter? Why might this be important to you?
2. When do you use distance, rate, and time calculations in your life? Why would it be helpful to calculate distance, rate, or time?



NAME \_\_\_\_\_

## Calculating Scale and Perimeter worksheet

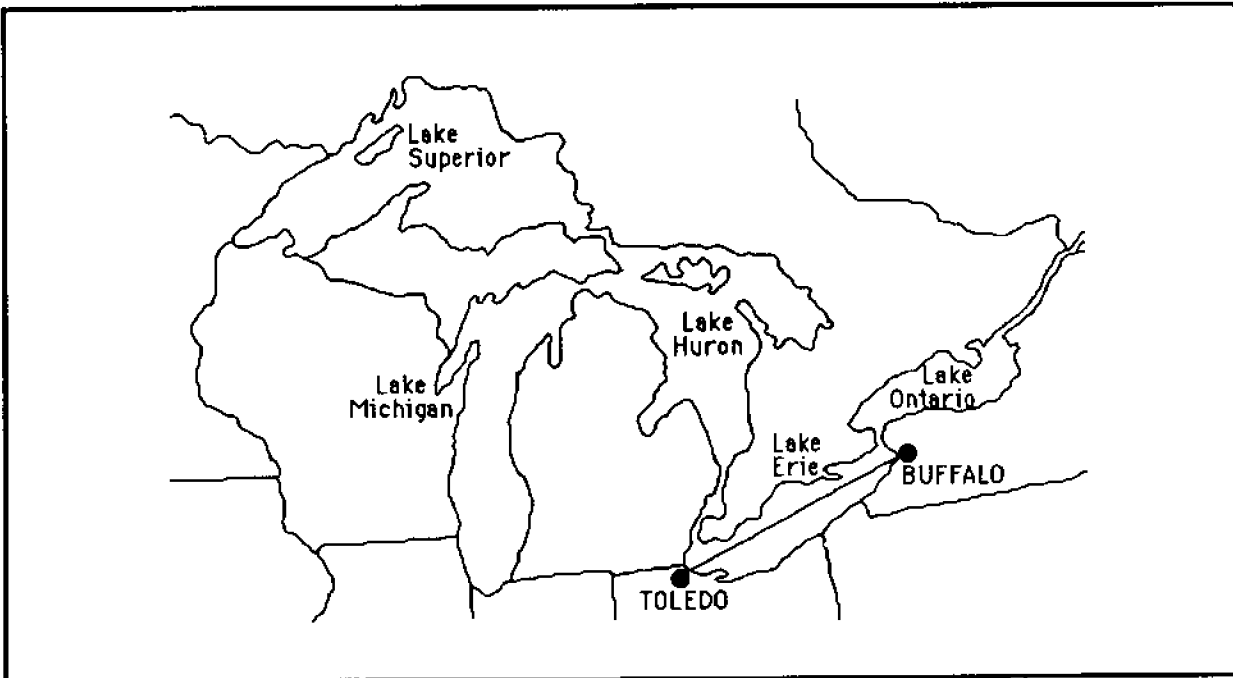

1. Find the city of Toledo, Ohio, on the map. Now find Buffalo, New York. It is **400 kilometers (km)** from Toledo to Buffalo by water. Use your ruler to measure the distance in centimeters (cm) between Toledo and Buffalo along the route shown on the map. Write this distance in the space below.

Distance in centimeters: \_\_\_\_\_

2. How many kilometers are represented by each centimeter? Divide 400 kilometers by the number of centimeters you measured. Show your work in the space below.

$$400 \text{ km} \div \text{_____ cm} = \text{_____ km/cm}$$

This is the **scale** of your map. 1 cm on the map represents \_\_\_\_\_ km in real life.

3. **Perimeter** is the distance around an object. To find the perimeter of a square or rectangle, measure all four sides and add the measurements together. To find the perimeter of an irregular shape is more difficult. How would you find the perimeter of the shape at the top of the next page?

## Calculating Scale and Perimeter worksheet

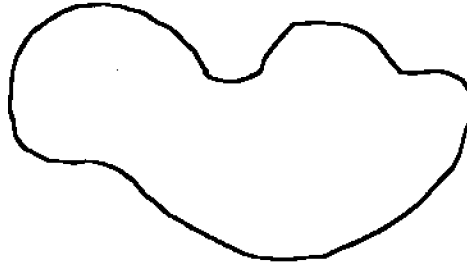

4. One way you can find the approximate perimeter is to space dots around the irregular object, then connect the dots with lines. Measure each of the segments and add the lengths of each segment together to find their total length. Measure the segments on this shape and write their total length in the space provided.

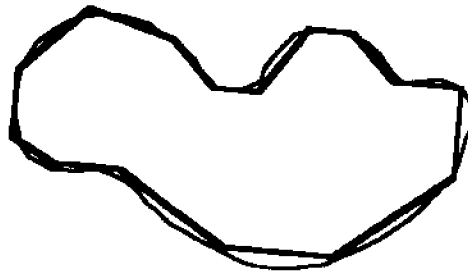

Perimeter = \_\_\_\_\_ cm

5. Draw dots around the border of Lake Superior on the map. Estimate the perimeter in centimeters by measuring and adding the distances between the dots. Multiply the result by the scale of the map to calculate the perimeter in kilometers:

\_\_\_\_\_ cm X \_\_\_\_\_ km/cm = \_\_\_\_\_ km

6. A closer approximation of perimeter may be found using a piece of string. Lay the string along the outside of the shape you are measuring, then measure the length of the string. Use this method to determine the perimeter of Lake Superior in centimeters, then multiply by your scale.

\_\_\_\_\_ cm X \_\_\_\_\_ km/cm = \_\_\_\_\_ km

7. Which of your two calculations do you think is closer to the actual perimeter of Lake Superior? Why would this be true?

---



---

## ANSWER KEY—Calculating Scale and Perimeter worksheet

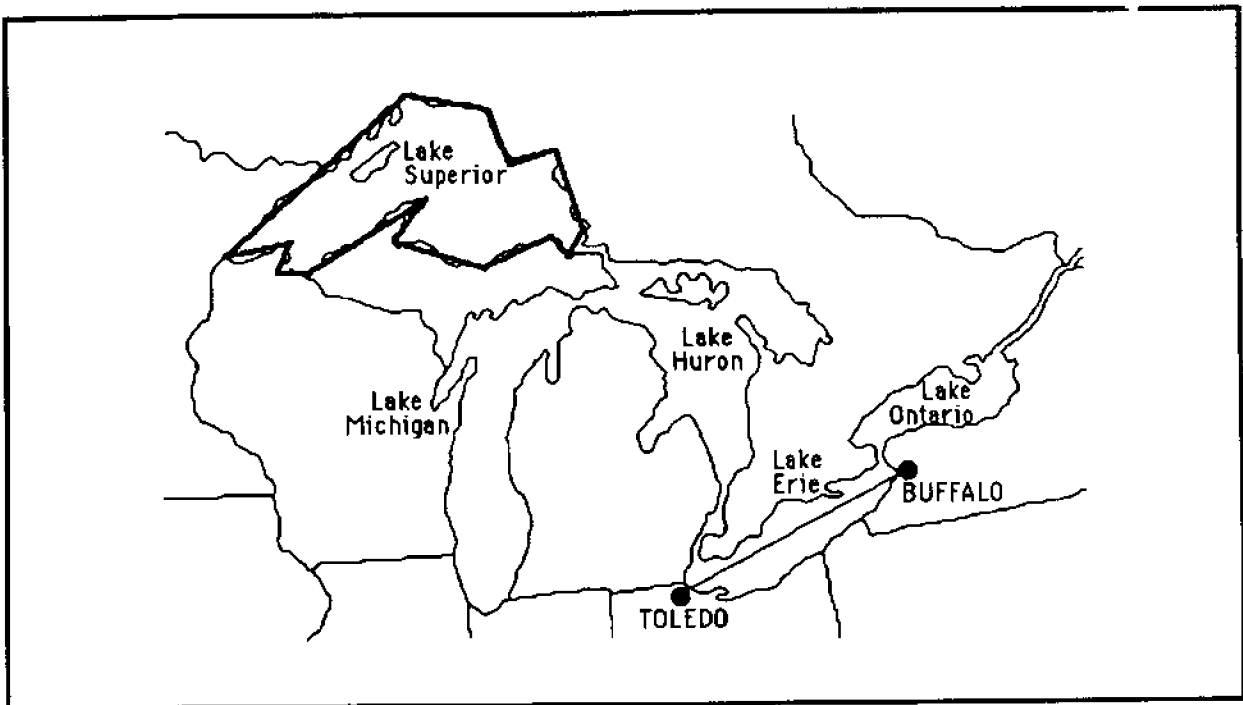

1. Find the city of Toledo, Ohio, on the map. Now find Buffalo, New York. It is **400 kilometers (km)** from Toledo to Buffalo by water. Use your ruler to measure the distance in centimeters (cm) between Toledo and Buffalo along the route shown on the map. Write this distance in the space below.

Distance in centimeters: 3.5 cm

2. How many kilometers are represented by each centimeter? Divide 400 kilometers by the number of centimeters you measured. Show your work in the space below.

$$400 \text{ km} \div \underline{3.5} \text{ cm} = \underline{114.3} \text{ km/cm}$$

This is the **scale** of your map. 1 cm on the map represents 114.3 km in real life.

3. **Perimeter** is the distance around an object. To find the perimeter of a square or rectangle, measure all four sides and add the measurements together. To find the perimeter of an irregular shape is more difficult. How would you find the perimeter of the shape at the top of the next page?

## ANSWER KEY—Calculating Scale and Perimeter worksheet

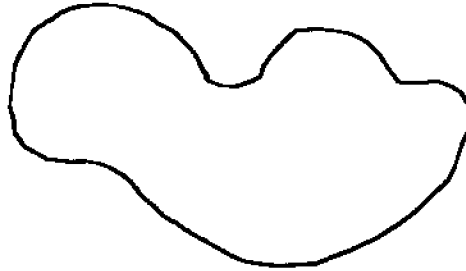

4. One way you can find the approximate perimeter is to space dots around the irregular object, then connect the dots with lines. Measure each of the segments and add the lengths of each segment together to find their total length. Measure the segments on this shape and write their total length in the space provided.

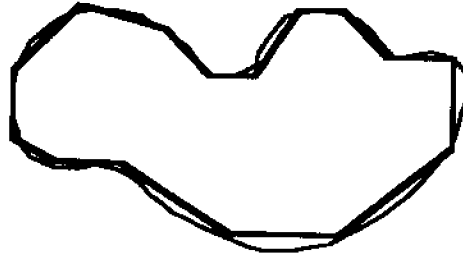

Perimeter = 17.2 cm

5. Draw dots around the border of Lake Superior on the map. Estimate the perimeter in centimeters by measuring and adding the distances between the dots. Multiply the result by the scale of the map to calculate the perimeter in kilometers:  
*Answer will vary but should be close to this.:*

$$\underline{16.2} \text{ cm} \times \underline{114.3} \text{ km/cm} = \underline{1851.7} \text{ km}$$

6. A closer approximation of perimeter may be found using a piece of string. Lay the string along the outside of the shape you are measuring, then measure the length of the string. Use this method to determine the perimeter of Lake Superior in centimeters, then multiply by your scale.

$$\underline{18.9} \text{ cm} \times \underline{114.3} \text{ km/cm} = \underline{2160.3} \text{ km}$$

7. Which of your two calculations do you think is closer to the actual perimeter of Lake Superior? Why would this be true?

*The second measurement is closest because it includes the curves of the outline.*

NAME \_\_\_\_\_

## Distance, Rate, and Time worksheet

Problems that deal with distance, speed, and time needed to go from place to place are called "distance, rate and time" problems. There is a set of formulas that can be used to calculate these values:

$$\text{DISTANCE} = \text{RATE} \times \text{TIME} \quad (D = R \times T)$$

$$\text{RATE} = \text{DISTANCE} \div \text{TIME} \quad (R = D/T) \quad \text{TIME} = \text{DISTANCE} \div \text{RATE} \quad (T = D/R)$$

Use these formulas to solve the following problems. Show your work on the back of this page.

**Example:** If the current pushed Paddle around Lake Superior at a rate of 2 kilometers per hour, **how long** would it take him to go from Thunder Bay to Duluth, a distance of 260 kilometers?

$$\text{Use } T = D/R \quad T = 260 \text{ km} \div 2 \text{ km/hr} = \mathbf{130 \text{ hours}}$$

1. If the wind blew with the current and pushed Paddle faster so that it took him 100 hours to go the same distance, **how fast** was he travelling?  
\_\_\_\_\_

2. A ship sets sail for Buffalo from Toledo going 40 km/hr. The ship reaches Buffalo 10 hours later. **How far** is it from Toledo to Buffalo by water?  
\_\_\_\_\_

3. A man on a motor bike leaves Toledo at the same time as the ship. It is 480 km to Buffalo by road. If the man travelled at 40 km/hr, **how long** did he ride?  
\_\_\_\_\_

4. **How fast** would you have to drive in order to arrive at Buffalo at the same time the ship arrives? **Hint:** Use the land distance from problem 3 and the ship's travel time from problem 2 to solve  $R = D/T$ .  
\_\_\_\_\_

5. If you had a choice of going from Toledo to Buffalo in a car travelling at 80 km/hr or by ship travelling at 40 km/hr, which would you choose if:  
a) You wanted to get to Buffalo the **shortest** way? \_\_\_\_\_  
b) You wanted to get to Buffalo the **fastest** way? \_\_\_\_\_

## ANSWER KEY—Distance, Rate, and Time worksheet

Problems that deal with distance, speed, and time needed to go from place to place are called “distance, rate and time” problems. There is a set of formulas that can be used to calculate these values:

$$\text{DISTANCE} = \text{RATE} \times \text{TIME} \quad (D = R \times T)$$

$$\text{RATE} = \text{DISTANCE} \div \text{TIME} \quad (R = D/T) \quad \text{TIME} = \text{DISTANCE} \div \text{RATE} \quad (T = D/R)$$

Use these formulas to solve the following problems. Show your work on the back of this page.

### Example

If the current pushed Paddle around Lake Superior at a rate of 2 kilometers per hour, how long would it take him to go from Thunder Bay to Duluth, a distance of 260 kilometers?

$$\text{Use } T = D/R \quad T = 260 \text{ km} \div 2 \text{ km/hr} = 130 \text{ hours}$$

1. If the wind blew with the current and pushed Paddle faster so that it took him 100 hours to go the same distance, how fast was he travelling?

$$R = D/T \quad R = 260 \text{ km} \div 100 \text{ hours} = 2.6 \text{ km/hour}$$

---

2. A ship sets sail for Buffalo from Toledo going 40 km/hr. The ship reaches Buffalo 10 hours later. How far is it from Toledo to Buffalo by water?

$$D = R \times T \quad D = 40 \text{ km/hour} \times 10 \text{ hours} = 400 \text{ km}$$

---

3. A man on a motor bike leaves Toledo at the same time as the ship. It is 480 km to Buffalo by road. If the man travelled at 40 km/hr, how long did he ride?

$$T = D/R \quad T = 480 \text{ km} \div 40 \text{ km/hour} = 12 \text{ hours}$$

---

4. How fast would you have to drive in order to arrive at Buffalo at the same time the ship arrives? Hint: Use the land distance from problem 3 and the ship's travel time from problem 2 to solve  $R = D/T$ .

$$R = 480 \text{ km} \div 10 \text{ hours} = 48 \text{ km/hour}$$

---

5. If you had a choice of going from Toledo to Buffalo in a car travelling at 80 km/hr or by ship travelling at 40 km/hr, which would you choose if:

a) You wanted to get to Buffalo the shortest way? By boat—distance by water is shorter

---

b) You wanted to get to Buffalo the fastest way? By car:  $R = D/T$   $R = 480 \text{ km on land} \div 80 \text{ km/hour} = 6 \text{ hours}$  Travel time by boat is 10 hours (from problem 2)

---

---

## Uses of Iron Ore

---

### Introduction

Paddle drifted along the shore of Lake Superior until he reached the port cities of Duluth, Minnesota, and Superior, Wisconsin, at its far western tip. He turned red from the iron dust that sifted down on him as he floated under a dock. Most of the ships in these ports load iron ore for transport to other ports on the Great Lakes and even across the ocean. Iron is a very important resource for making steel and many other products. Most people use something made from iron every day of their lives.

### Objectives

When the students have completed this activity, they will be able to identify the Duluth-Superior ports on a map, name some Great Lakes cities that import iron ore, and identify at least five products in everyday use that are made from iron.

### Materials

Iron Ore worksheet (master on page 84), pencil or pen.

### Terms to Know:

**Export**—to send a product to another place

**Import**—to bring in a product from another place

### Procedure

1. Think of things you use every day that are made from iron ore. Create a bulletin board about the uses of iron ore. Draw pictures, cut pictures from magazines, or bring in photographs to illustrate each of the uses you listed. Make captions for your illustrations. You may want to classify the uses of iron ore into categories like industrial uses, recreational uses, uses in the home, and so on. How many uses did you find?
2. Complete the **Iron Ore** worksheet.
3. Find out more about where iron comes from and how it is used. You may want to invite guest speakers to discuss iron mining, forging, steelmaking, or the auto industry. Or write to industries for more information. Follow the directions for writing a business letter on page 21 to request information about iron ore and its uses.

NAME \_\_\_\_\_

## Iron Ore worksheet

Use the map below to help you answer the following questions.

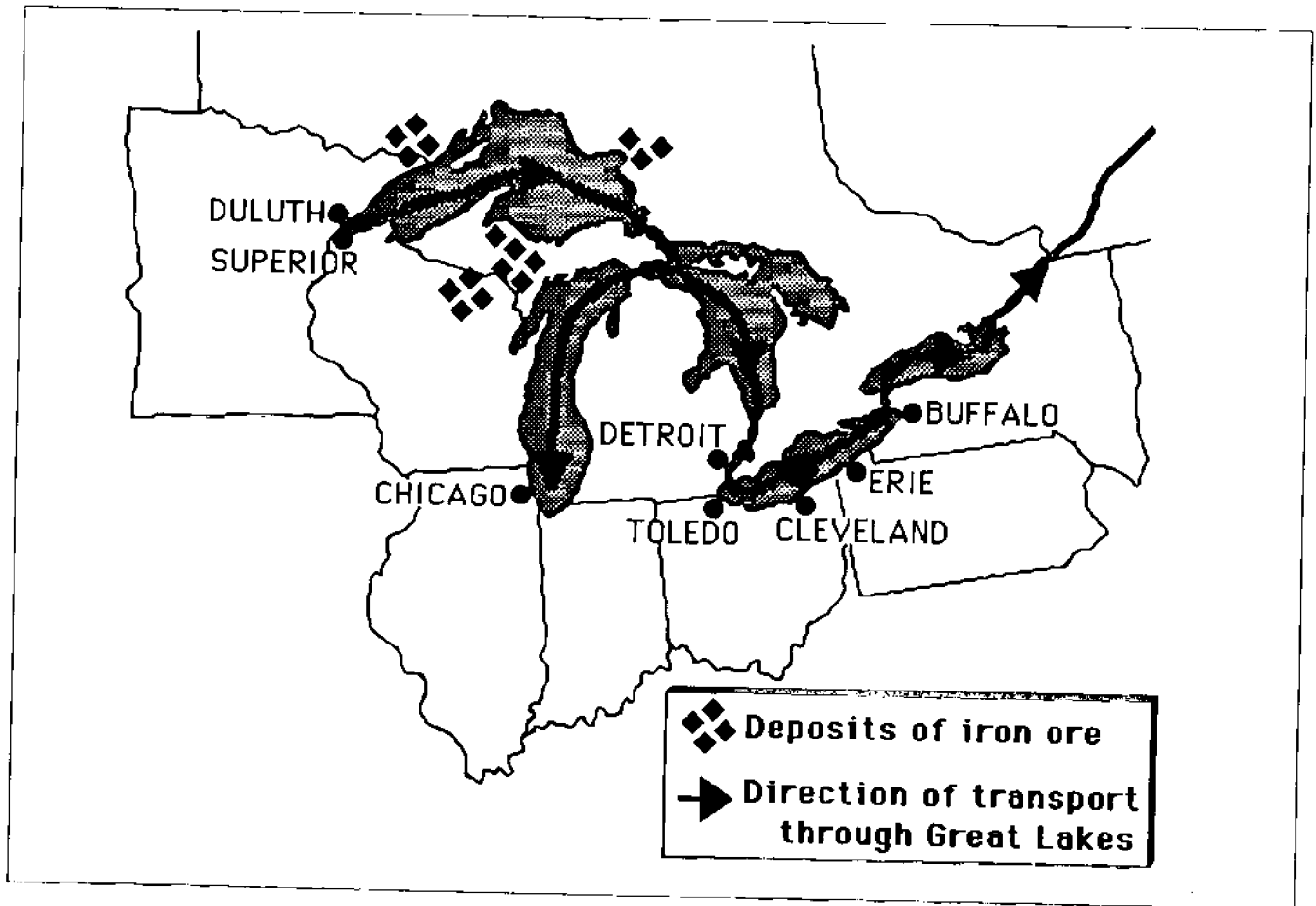

1. Around which of the Great Lakes are most deposits of iron ore located? \_\_\_\_\_  
\_\_\_\_\_
2. Why do you think Duluth-Superior and Thunder Bay are the main exports of iron ore? \_\_\_\_\_  
\_\_\_\_\_
3. Name three cities that import iron ore. \_\_\_\_\_  
\_\_\_\_\_
4. What are two major industries in these cities? \_\_\_\_\_  
\_\_\_\_\_
5. Why is iron ore important to these industries? \_\_\_\_\_  
\_\_\_\_\_



## ANSWER KEY—Iron Ore worksheet

Use the map below to help you answer the following questions.

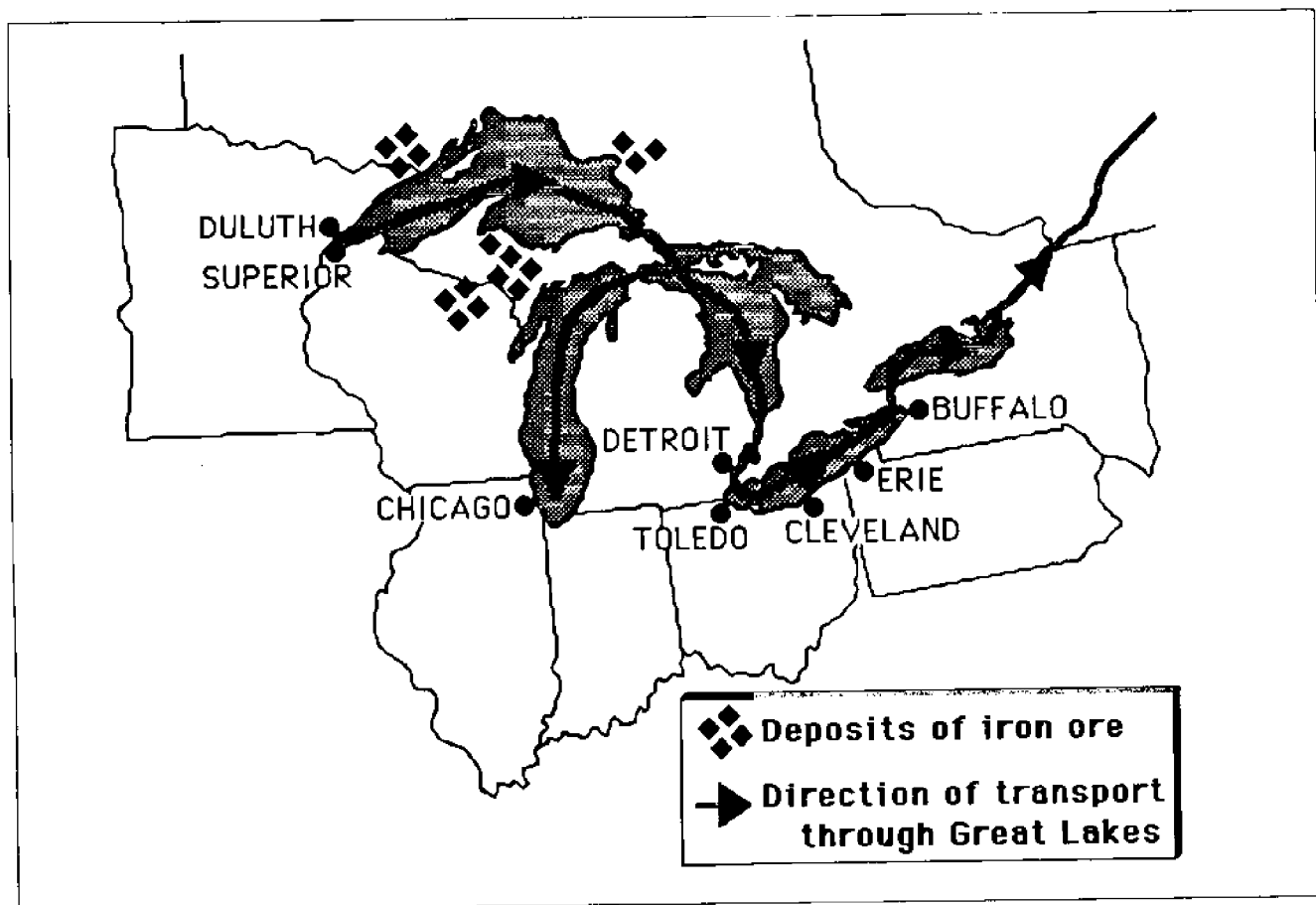

1. Around which of the Great Lakes are most deposits of iron ore located? Lake Superior
2. Why do you think Duluth-Superior and Thunder Bay are the main exports of iron ore? They are close to the iron deposits.
3. Name three cities that import iron ore. Accept any three: Buffalo, Chicago, Cleveland, Detroit, Erie, Toledo, Hamilton
4. What are two major industries in these cities? Steelmaking, automobile making.
5. Why is iron ore important to these industries? Iron is necessary to make steel; steel is used in making cars.

---

# Something's Fishy

Adapted from OEAGLS EP-032, *Build a Fish to Scale*

---

## Introduction

Fishing is an important business on the Great Lakes. Paddle met many fish on his journey. A fish thought Paddle would make a good dinner. Fishermen on Lake Superior pulled Paddle in with their catch and a French fishing boat carried him across the Atlantic Ocean.

## Objective

When students have completed this activity, they will be able to identify the basic parts of a fish's external anatomy.

## Materials

**Fish Anatomy** identification and description sheets, **Fish puzzle** (masters on pages 87-92); and **Fish Anatomy** worksheet (master on page 93), tape or tacks.

## Procedure

1. Make overhead transparencies of the **Fish Anatomy** identification pages. Ask students to guess what each part does for the fish. Then review written descriptions of each part (page 88) with the class.
2. Play a matching game with the **Fish puzzle** pieces and the written descriptions of the fish parts. Make copies and cut out each part and each description. Turn all the pieces face down and mix them up. Draw a piece at random. Have students name and describe the part pictured or name the part that is described verbally.
3. Play "Pin the Fin on the Fish." Make copies and cut out each piece of the **Fish puzzle** along its outline (the pieces will need to fit together exactly to complete the picture). Arrange the parts face up but not in any particular order. Draw a description of a part at random. Have students identify the part described. Tape or tack the picture of that part to the chalk board or bulletin board. The first piece may be placed anywhere, but each succeeding piece must be placed in its proper location on the fish. Do this activity with the class as a whole or make a set of puzzle pieces and description cards for each of two or more teams and see which team first correctly completes the fish picture. (Glue the puzzle pieces to lightweight cardboard or laminate them for more durability.)
4. Complete the **Fish Anatomy** worksheet.

## Extension Activity

Create your own fish. Directions are on page 95.

# Fish Anatomy identification

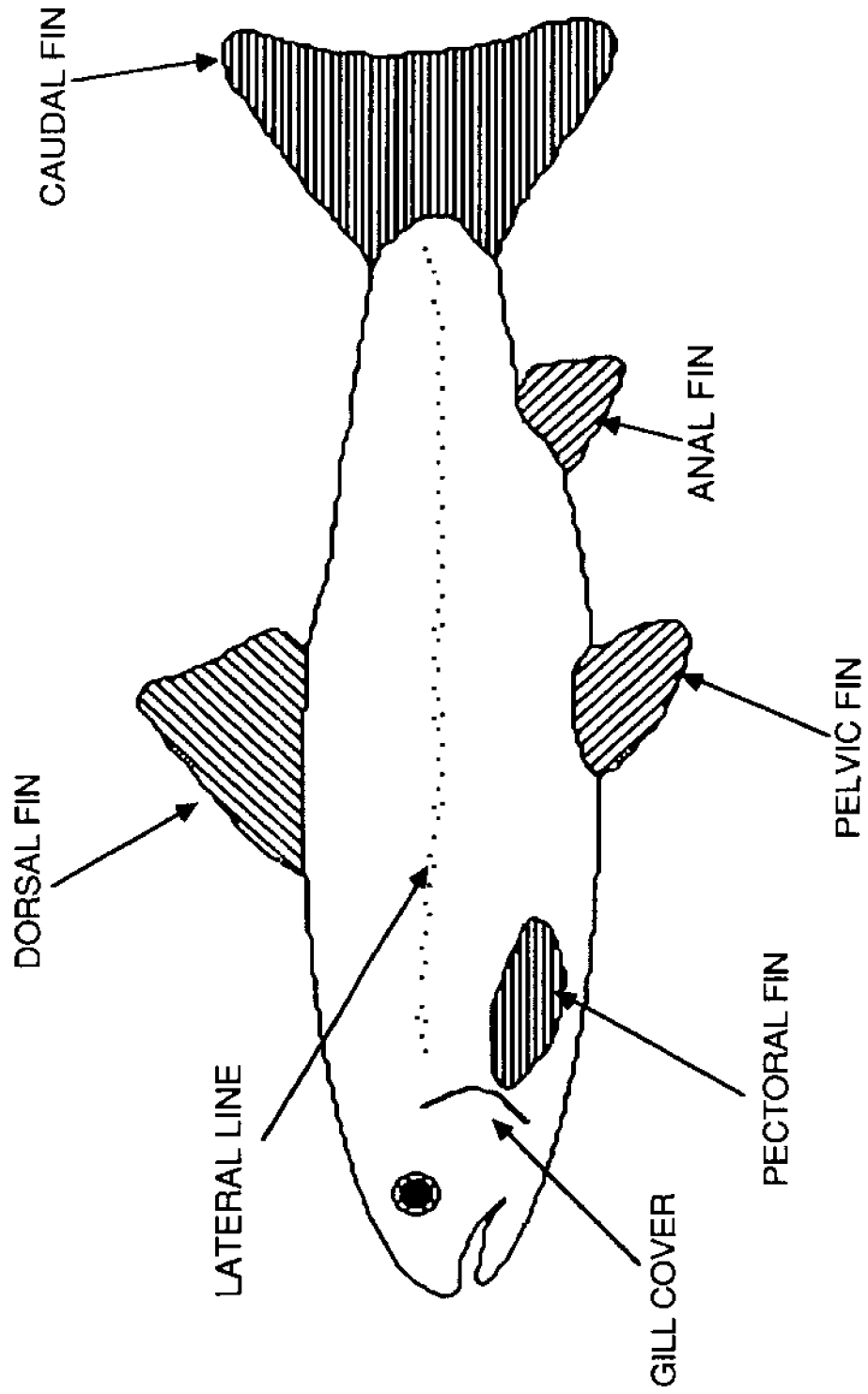

## **FISH ANATOMY DESCRIPTIONS**

### **GILL COVER**

Covers and protects the gills.  
Fish absorb oxygen from water  
as it passes over the gills.

### **LATERAL LINE**

Special sensory organs located  
in a line along the fish's side.  
These organs are sensitive to  
changes in pressure and to  
chemicals dissolved in the  
water.

### **DORSAL FIN**

Some fish have only one; others  
have two or none. These fins  
are located on the fish's back.

### **CAUDAL FIN**

This fin is located at the end of  
the fish's tail. Pushing the  
caudal fin back and forth in the  
water provides power for the  
fish to move and helps in  
changing direction.

### **ANAL FIN**

This fin is located on the fish's  
belly close to its tail.

### **PELVIC FIN**

Located on a fish's body where  
legs are located on a human's  
body. They help to control the  
fish's motion. Sometimes they  
are modified to help the fish  
crawl along the bottom.

### **PECTORAL FIN**

Located on a fish's body where  
arms are located on a human's  
body. They help to control the  
fish's motion.

# Fish Puzzle pieces

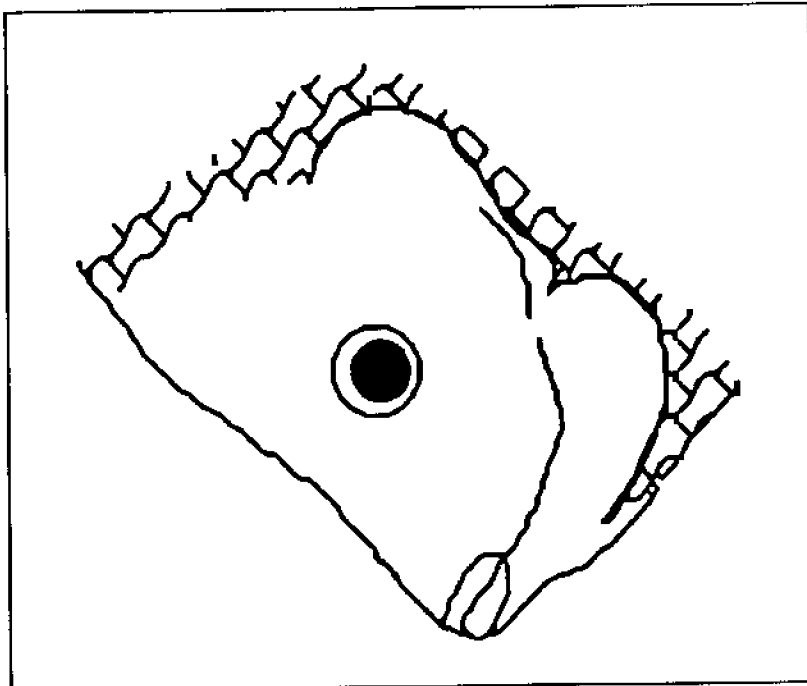
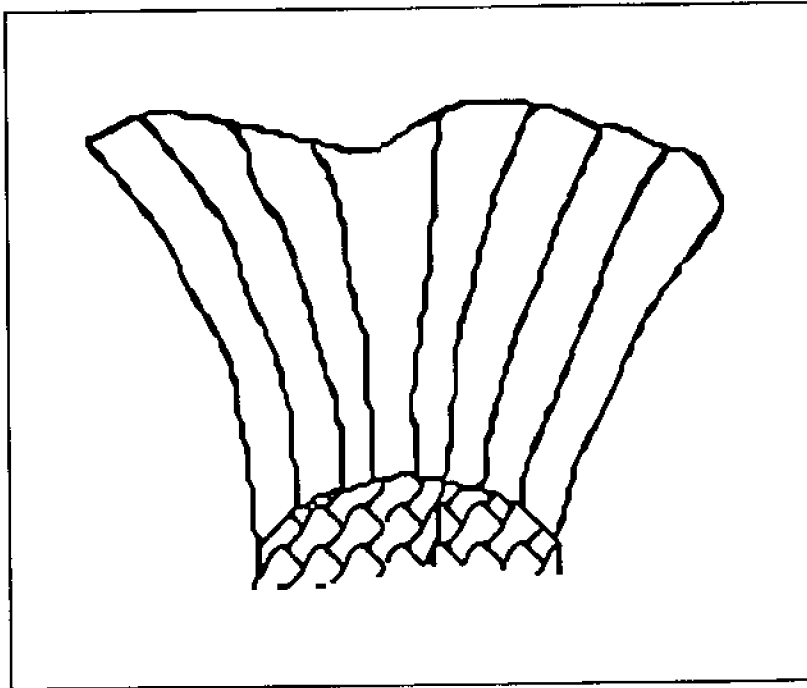

Fish Puzzle pieces

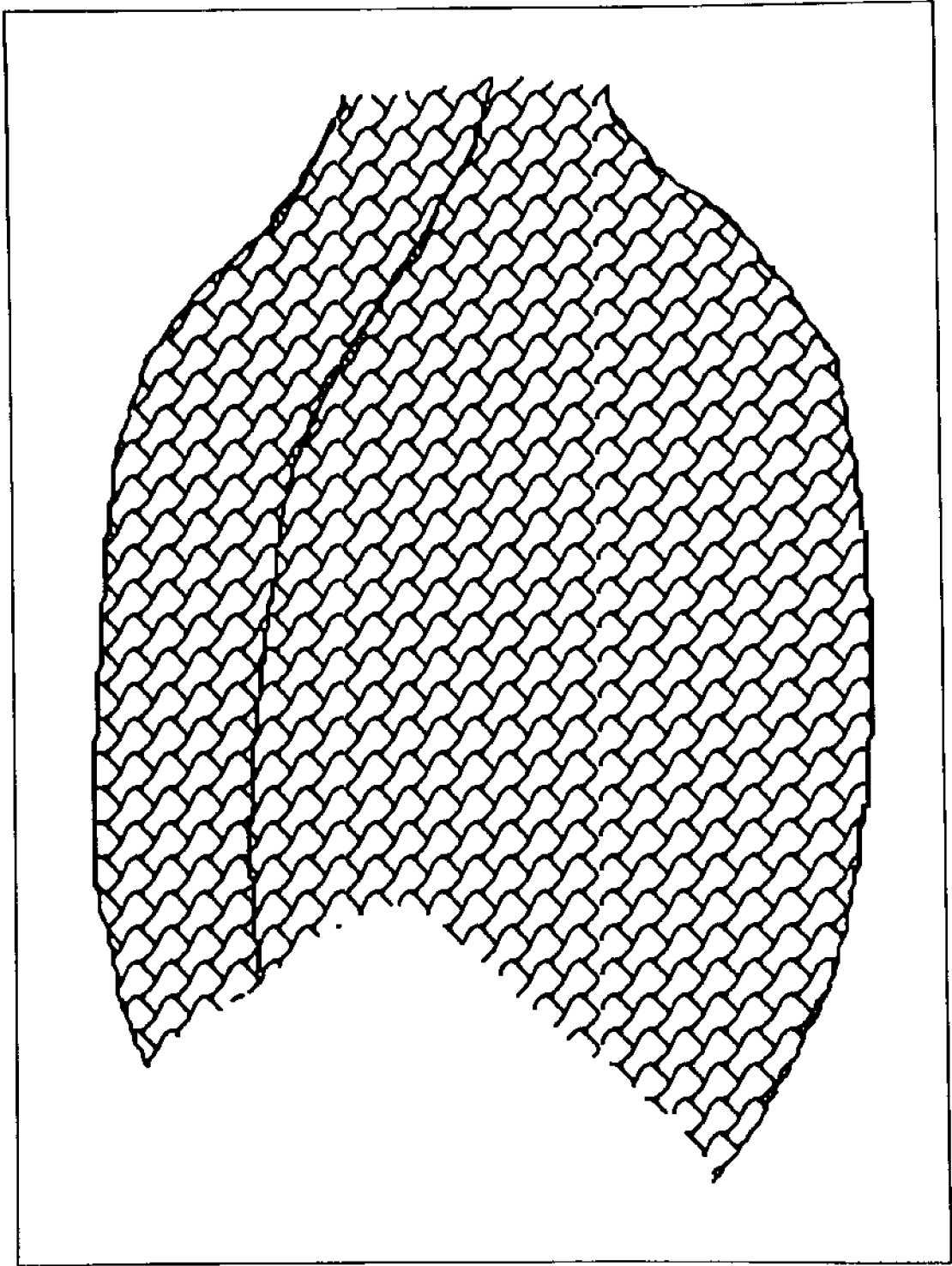

# Fish Puzzle pieces

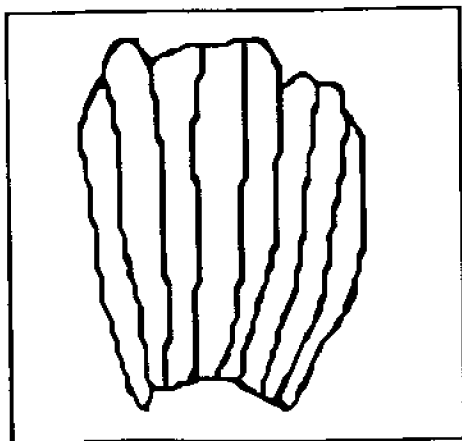
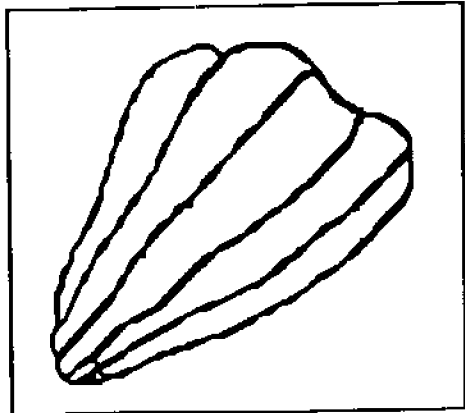
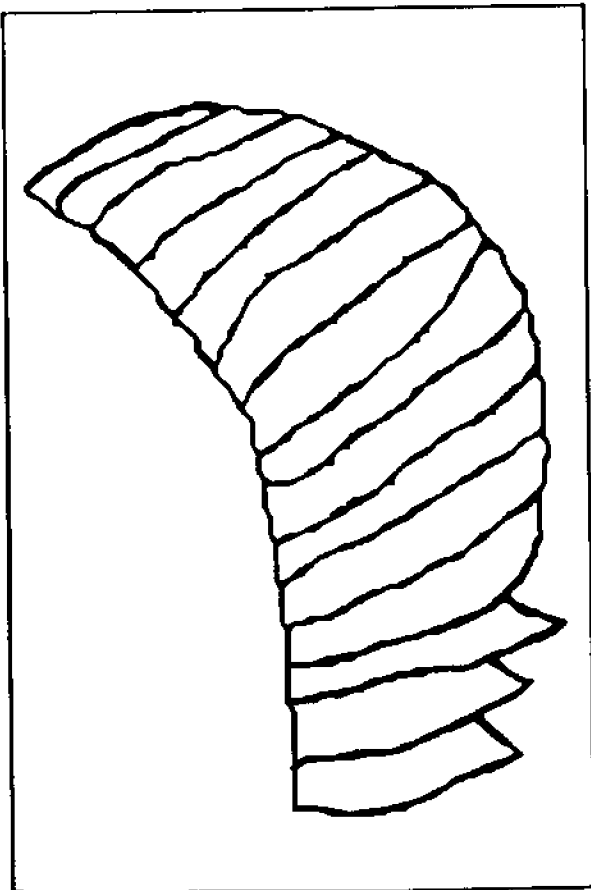
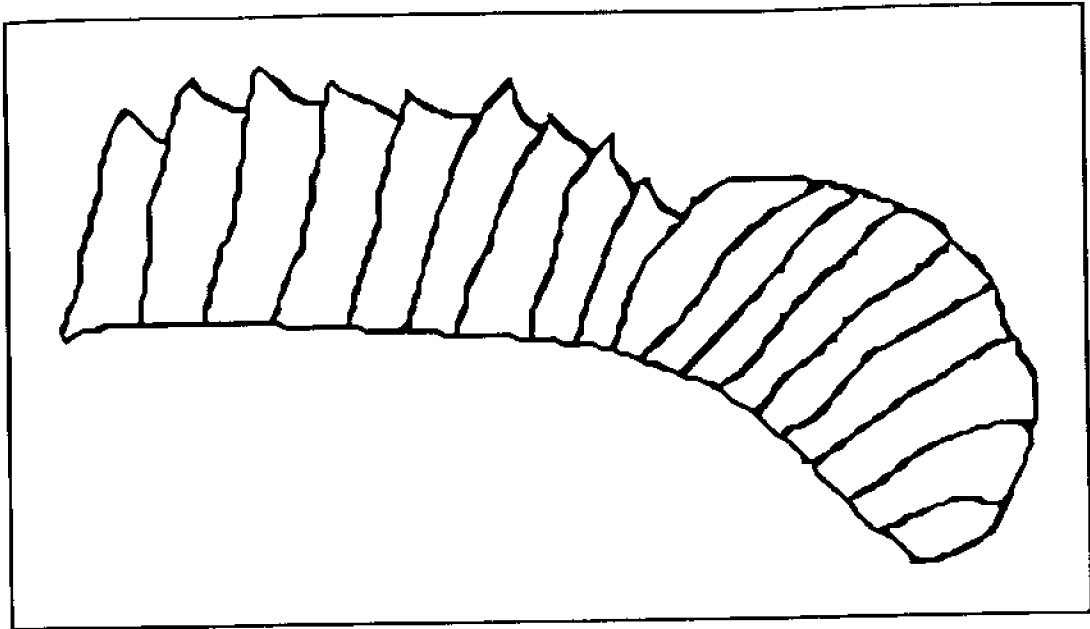

# Fish Puzzle key

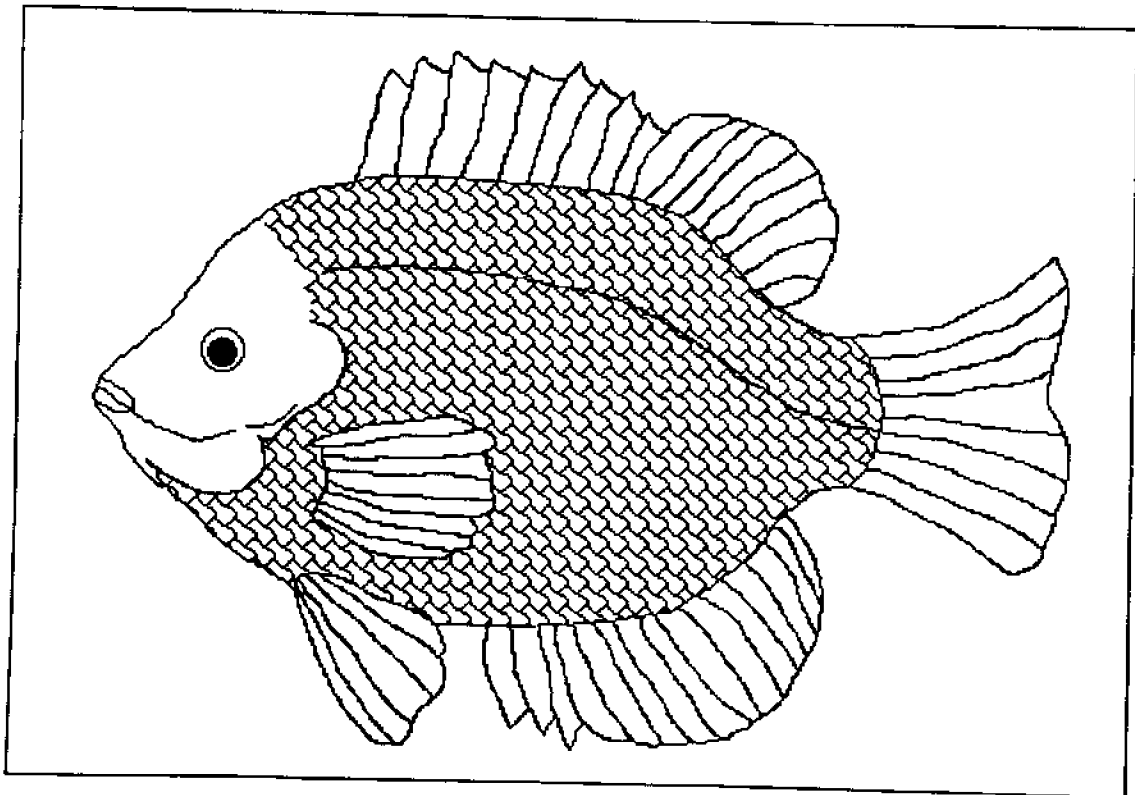
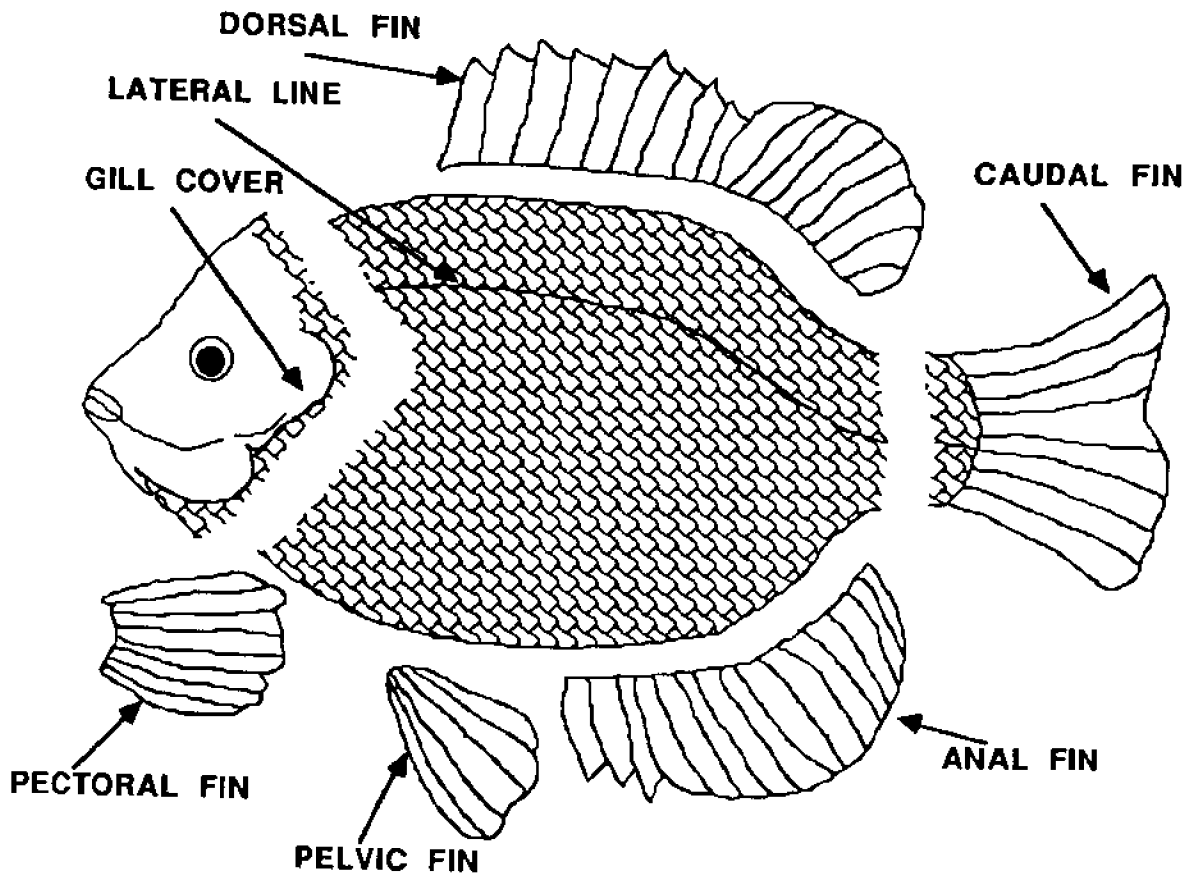



NAME \_\_\_\_\_

## Fish Anatomy worksheet

Write the letter of each fish part in the blank by its description. Then label the diagram with the name of each part.

- |                 |  |
|-----------------|--|
| A. Caudal fin   | _____ Protects gills   |
| B. Pectoral fin | _____ Fin located on a fish's back   |
| C. Lateral line | _____ Provides power and helps in changing direction   |
| D. Gill cover   | _____ Fin located near a fish's tail   |
| E. Pelvic fin   | _____ Fins located on a fish where legs would be on humans; may be modified for special uses |
| F. Anal fin     | _____ Fins located on a fish where arms would be on humans; helps adjust movements           |
| G. Dorsal fin   | _____ Sensory organ sensitive to changes in pressure or chemicals in the water               |

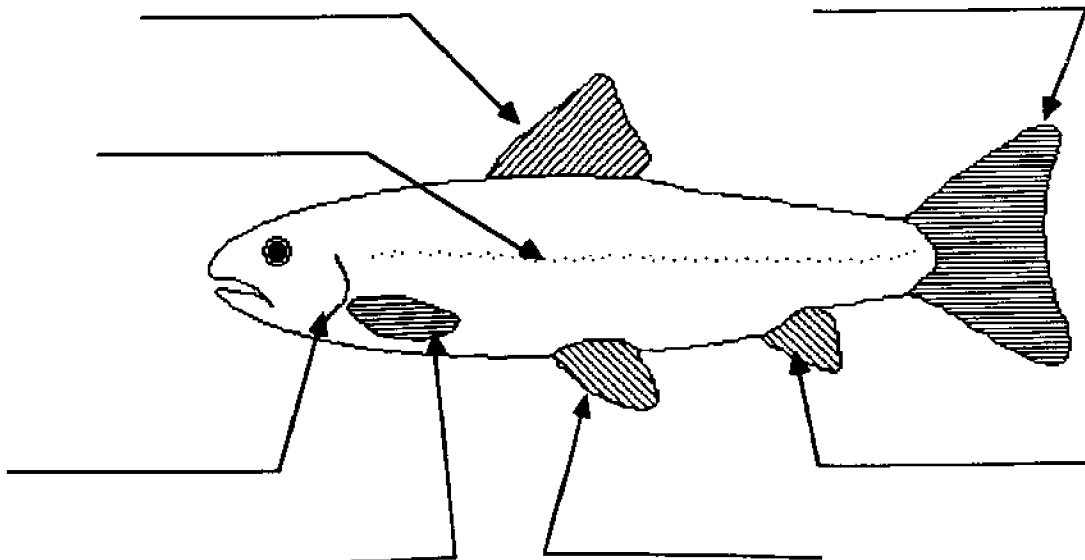

## ANSWER KEY—Fish Anatomy worksheet

Write the letter of each fish part in the blank by its description. Then label the diagram with the name of each part.

A. Caudal fin

B. Pectoral fin

C. Lateral line

D. Gill cover

E. Pelvic fin

F. Anal fin

G. Dorsal fin

  D   Protects gills

  G   Fin located on a fish's back

  A   Provides power and helps in changing direction

  F   Fin located near a fish's tail

  E   Fins located on a fish where legs would be on humans; may be modified for special uses

  B   Fins located on a fish where arms would be on humans; helps adjust movements

  C   Sensory organ sensitive to changes in pressure or chemicals in the water

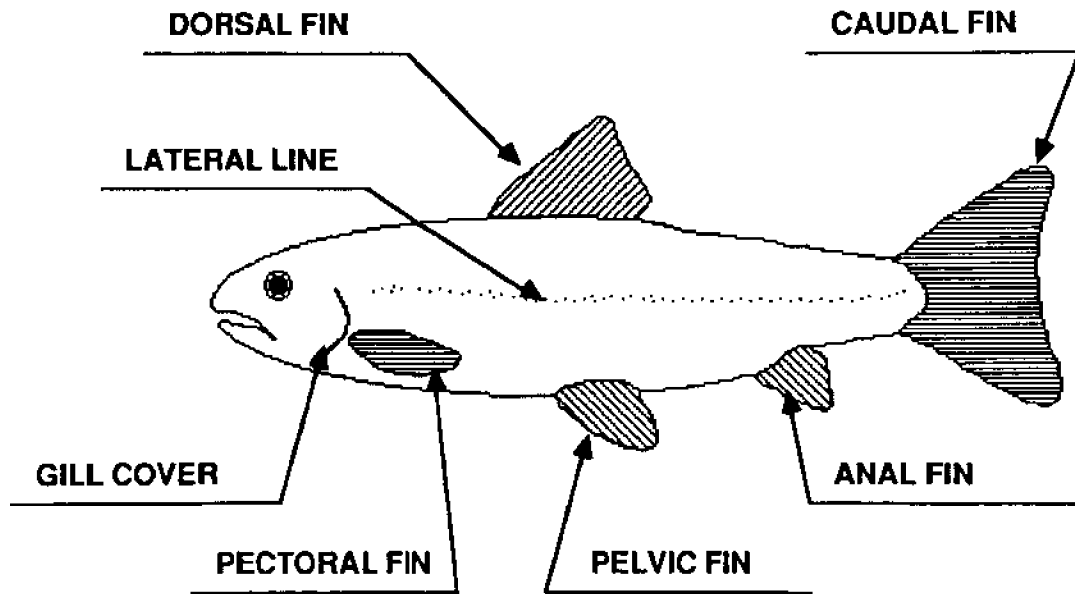

---

# Going Fishing

---

## Objective

When students have completed this activity, they will have “built” their own fish which includes all the parts shown on the **Fish Anatomy** worksheet.

## Materials

Large sheet of construction paper (18 X 24 inches) for each student, scrap paper, crayons or paint, scissors, glue, stapler, and yarn.

## Procedure

1. Fold your piece of construction paper in half (along either the length or the width).
2. On one side of the folded paper, draw the outline of a fish. Add the gill cover and lateral line.
3. Cut out your fish along the outline you drew. Cut through both thicknesses of paper at once. You will have two fish when you finish.
4. Place your two fish nose to nose and color the side that is up. Use pieces of scrap paper to make fins. Glue or staple them to your fish in the proper places. Make sure you have included all the parts named on your **Fish Anatomy** worksheet. Remember that pectoral and pelvic fins come in pairs like your arms and legs.
5. Staple the two main pieces of the fish together around the edges leaving an opening big enough for your hand to fit inside.
6. Crumple pieces of scrap paper and lightly stuff your fish. Don't overstuff! Be sure that you can close the opening without straining the paper.
7. Staple the opening closed.
8. Attach a string to the mouth of your fish. You've hooked a big one! Hang the fish around the room.
9. Share your fish with the class. Show and name the parts you included on your fish. Did you include them all?

---

# Thunderbirds and Sunsets

---

## Introduction

Today, meteorologists use barometers, computers, and satellites to predict what the weather will be like days in advance. But long ago there were no meteorologists and no electronic tools to use. People made up stories to explain how different kinds of weather happened and invented sayings based on their observations of plants and animals to predict the next day's weather. Chippewa legends say that thunderstorms happen when the thunderbird flies in search of prey. Can you think of any stories or sayings that you have heard that explain how weather events occur?

## Objectives

When they have completed this activity, students will be able to relate some weather legends and sayings. They will choose a weather event and make up an original "legend" to explain it.

## Materials

Paper, pencil or pen, markers or crayons, **Weather Folklore** background sheet (master on page 97), **Thunderbird** outline (master on page 98).

## Procedure

1. Read the **Weather Folklore** background sheet and discuss the signs and sayings. Which ones have you heard before? Which ones are new to you? Can you think of any other ones? What are they?
2. Discuss different types of weather—rain, fog, snow, or thunder, for example. Why do these things happen? What explanations might you imagine if you didn't know what caused them?
3. Choose your favorite weather event. Write a short "legend" to explain why this weather event occurs. Draw a picture to illustrate your story.
4. Choose some of the sayings you discussed earlier and illustrate them.
5. Color the **Thunderbird** picture. Use it as a cover for your collection of illustrated weather sayings. Or collect the original legends from each student and make your own class book of weather tales.

## Extension Activities

Read other weather folk tales. You might enjoy Washington Irving's *Rip Van Winkle*. Check your school library and the public library for other folk tales and legends about weather. Ask older people what weather folk tales they know; directions for learning about **Oral History** are on pages 99 and 100.

---

## Weather Folklore

Adapted from "Weather Forecasting and Folklore," by Dick Goddard,  
Cleveland State *Gamut*, Winter 1985.

---

Long ago, people searched for ways to predict storms and fair weather and drew conclusions based on their observations of nature. They believed that animals and plants were much closer to nature than humans, and so more sensitive to weather changes.

Here are some of the more popular "signs" that were supposed to indicate a hard winter to come:

- \* Thicker than normal corn husks.
- \* Woodpeckers sharing a tree.
- \* Thick hair on a cow's neck.
- \* Pigs gathering sticks.
- \* Woollybear caterpillars with thin orange bands and thick black bands.
- \* Squirrels rapidly gathering many nuts.



Such "rules for weather" based on animals or plants or the appearances of the skies were often passed along from generation to generation in the form of rhymes or jingles. Here are some of the more reliable ones:

*Red sky at dawning, sailor  
take warning.*

*Red sky at night, sailor's  
delight.*

*Ring around the sun or moon,  
Expect the Earth to puddle  
soon.*

*When teeth and bones and  
bunions ache,  
Look for clouds to fill the  
lake.*

*The sharper the blast,  
The sooner it's past.*

*It's a sign of rain or snow,  
When birds and bats fly low.*



*When dew is on the grass  
Rain will never come to pass.*

*Near the surface quick to  
bite,  
Catch your fish when rain's in  
sight.*

Sometimes people made up reasons for weather events. Many people believed that weather was caused by gods or spirits. The Chippewa believed in the Thunderbird, Northern Europeans believed in the thunder god Thor, and ancient Greeks thought storms at sea were caused by Poseidon. These beliefs are the basis of many popular legends today.



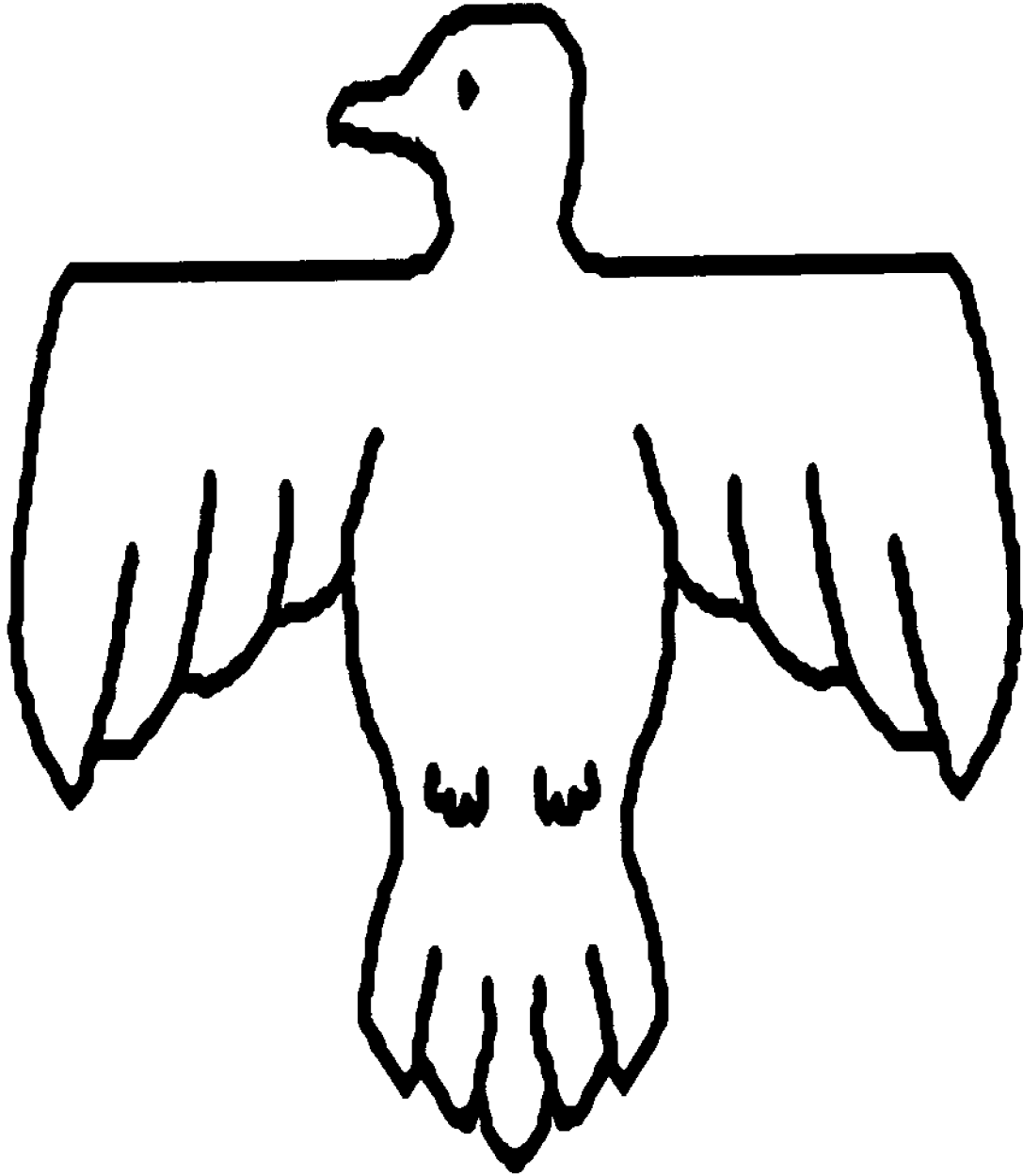

Thunderbird outline

---

# Oral History

---

## Introduction

When Paddle spent the winter with an old lady near Montreal, he heard her tell stories of the St. Lawrence River and its history. One of the most fascinating ways to learn history is by talking to people who have lived it. A discussion with an older person can provide valuable material for study and can also bring children closer to people in older generations.

## Objectives

When they have completed this activity, students will be able to conduct an informal interview to gather information on a historic or folk topic. They will be able to describe the value of learning from people who have lived with local history.

## Materials

Paper and pencil; older students may wish to use a cassette recorder as well.

## Procedure

1. Organize a "Grandparents and Special Friends Day." Each student invites one older person to come to school for an afternoon. Plan to have a snack with the guests and let them observe or participate in some classroom activities.
2. In advance, work with students to develop some questions that they can ask of their guests in personal conversations. Students should take notes or record the interview and share the responses with the class later. Some possible questions related to Paddle's adventures are:
  - \* What kinds of sayings about the weather did you learn when you were growing up? Which of the sayings seemed to come true?
  - \* Have you ever been fishing in the Great Lakes? What kinds of fish did you catch? Did you eat them? What was the fishing trip like?
  - \* When you were growing up, did your parents ever talk about the Great Lakes? What kinds of things did they say? What kinds of things do you tell your grandchildren about the lakes?
  - \* Do you remember the first time you saw one of the Great Lakes? What did you think of it?
3. Stress to students the importance of being kind and patient with the person who is interviewed. There are many stories to be told, and we may hear even better ones than those we asked for in our questions.

4. As an alternative to inviting guests to the classroom, have students interview a person in their neighborhood and report results to the class.
5. Make an anthology of the stories you heard. Write down your questions and your guests' responses. Illustrate the stories with drawings or photographs and make a cover for your collection. Share your personal history books with other classes.

### **Discussion Questions**

1. What can we learn about history from older people?
2. Why is this information valuable?
3. What similarities and differences did you notice in the stories you were told in answer to your questions?
4. Imagine you are 80 years old. What do you think you will tell your children about when you are old?
5. How do the stories you would tell differ from the stories you were told?  
How are they alike?



---

# Breeches Buoy Rescue

---

## Introduction

Paddle experienced a severe storm on Lake Superior and was witness to a dramatic rescue by “breeches buoy.” A lifeline from shore to a sinking vessel hauled sailors to safety one by one. Breeches buoys and marine rescue teams that use them have been famous on every coastline for many decades.

## Objectives

When the students have completed this activity, they will be able to describe how a breeches buoy is used to rescue people from sinking vessels.

## Materials

Tinker Toys or Erector Sets, nylon thread or fishing line, rubber bands, twist-off lids from 1-liter soft drink bottles, pennies.

## Procedure

1. Read about the *Breeches Buoy Rescue* in Chapter 14 and study the diagram of a breeches buoy in Chapter 15. The word *breeches* means trousers or pants. Can you see from the diagram how the breeches buoy got its name?
2. Have teams of students use Tinker Toys or Erector Set pieces to construct two scaffoldings, one to represent the sinking boat (a mast with lines attached), and one to represent a land-based rescue site (a tripod with a center pole where lines are attached). Use the wheels of the construction set as pulleys, and rig lines such as those that are used for some clotheslines. There will be at least 2 lines going between the boat and the land site. The diagrams on the next page illustrate the simplest completed set-up.
3. Make a “breeches buoy” using a deep lid large enough to hold several pennies as a load (the cap from a one-liter soft drink bottle is ideal). Attach lines to the lid with a rubber band as shown in the diagram on the next page. Tie the “buoy” to a wheel and fasten the wheel to the line around the pulleys between the “boat” and the “shore.” Move your buoy from the boat to shore by pulling on the lower line.
4. There are many ways to construct such a pulley system. Only the simplest has been illustrated. Have students experiment with the materials available to build other pulley systems and see which team can haul the largest number of pennies (the heaviest person!) in the buoy.

# Building a Breeches Buoy diagram

## Construct your "boat" and "rescue base"

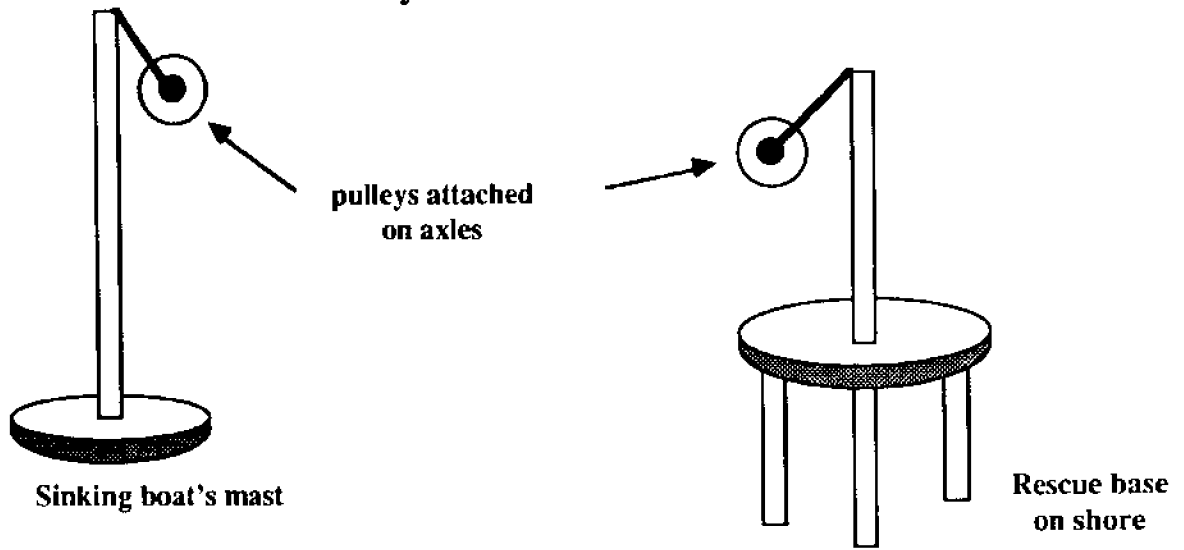

## Construct the buoy

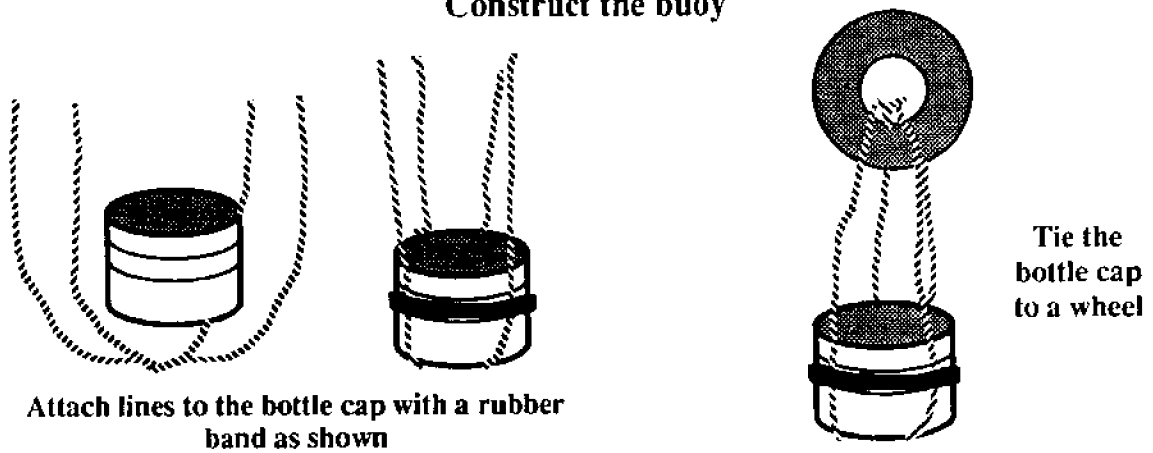

## Attach the buoy to the pulleys

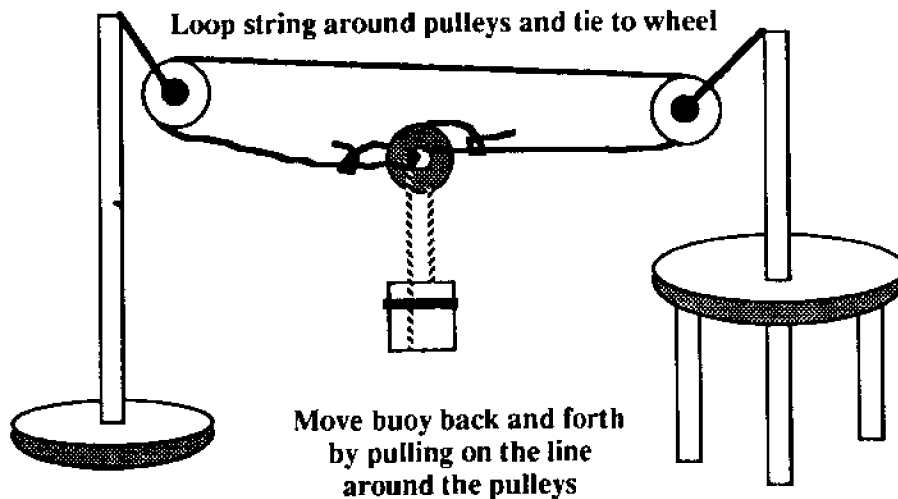

---

# How Locks Work

Adapted from OEAGLS EP-013, *Shipping on the Great Lakes*

---

## Introduction

Lake Superior is 602 feet (123 meters) above sea level. In order for ships to go from the Atlantic Ocean to the Great Lakes and back for international trade, the United States and Canada have constructed a series of **locks** that raise and lower boats to the levels of the lakes, rivers, and ocean. Because of this system, 80% of the world's cargo ships can now sail as far west as Lake Superior. Paddle spent the winter at the Soo Locks waiting for the spring thaw so he could go from Lake Superior into Lake Huron. We can build a model of a lock and use it to raise and lower a boat to three different water levels.

## Objectives

When students have completed this activity they will be able to explain how locks work to raise and lower boats between different elevations on the Great Lakes.

## Materials

Two half-gallon or quart milk cartons, small toy boat, sharp knife, modeling clay or fiber tape, water, sink or stream table, **How Navigational Locks Operate** diagrams and **Building Your Own Lock** directions (masters on pages 104-106).

## Terms to Know

**Lock**—human-made chamber on a waterway where water levels are raised and lowered to carry boats between bodies of water at different elevations

## Procedure

1. Make a transparency or give each student a copy of the **How Navigational Locks Operate** page. These diagrams show how a boat is lowered in a lock. A boat is raised by reversing the operation. No pumps are needed. The water flows from the higher level to the lower level until the water levels on each side of an open valve are the same. Ask students to describe the steps that would be taken to *raise* a boat in the lock.
2. You can make a working model of a lock to raise and lower a boat to three different water levels. Cooperate to make one model as a class project or have each student make one. A sharp paring knife works best for cutting the milk cartons. Carefully review the directions for **Building Your Own Lock** before beginning construction. Remind students to use knives safely and review the **Rules for Carving Safely** listed on page 6.

# How Navigational Locks Operate diagram

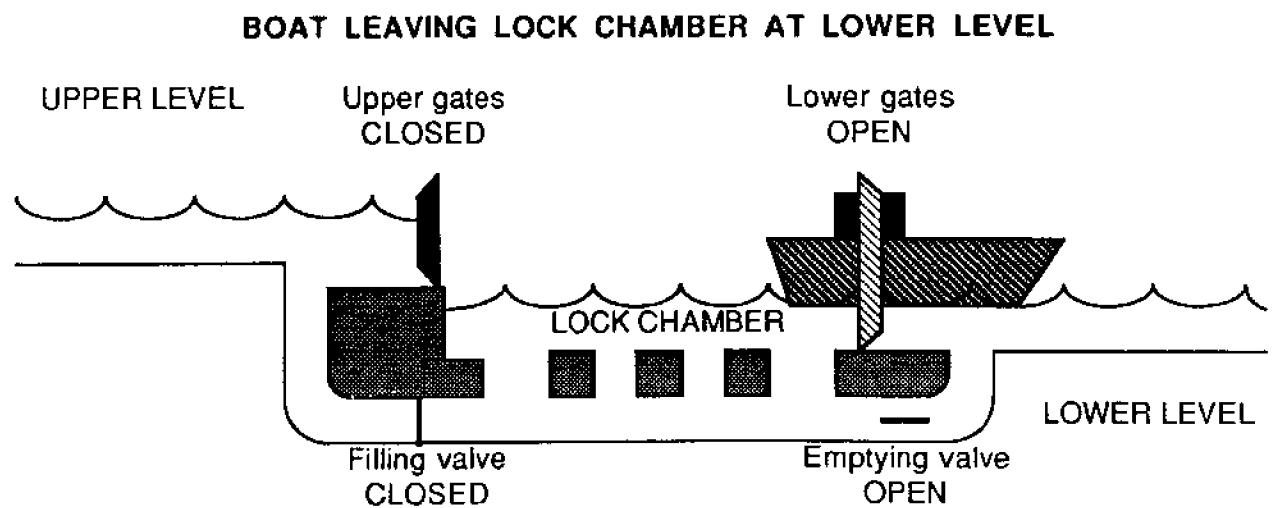
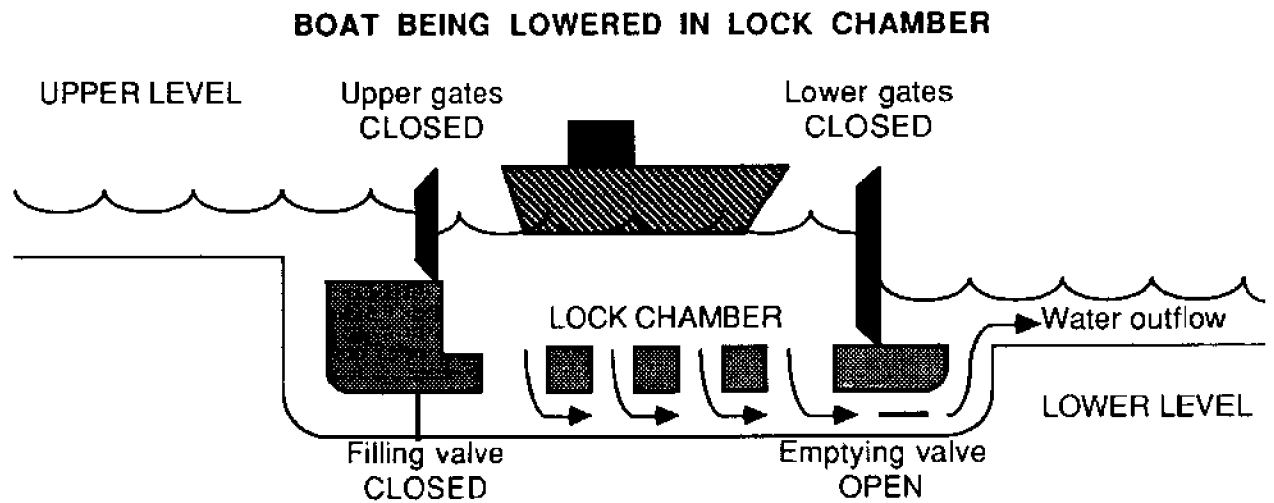
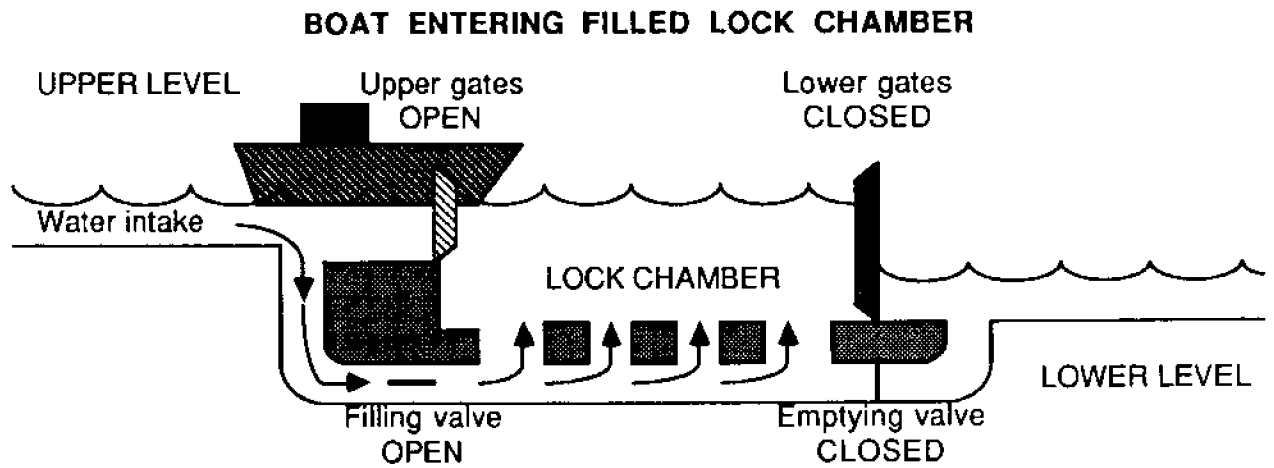

## Building Your Own Lock diagram

Follow these step-by-step instructions to build a working model of a lock.

1. Cut two milk cartons as shown in the diagram below:

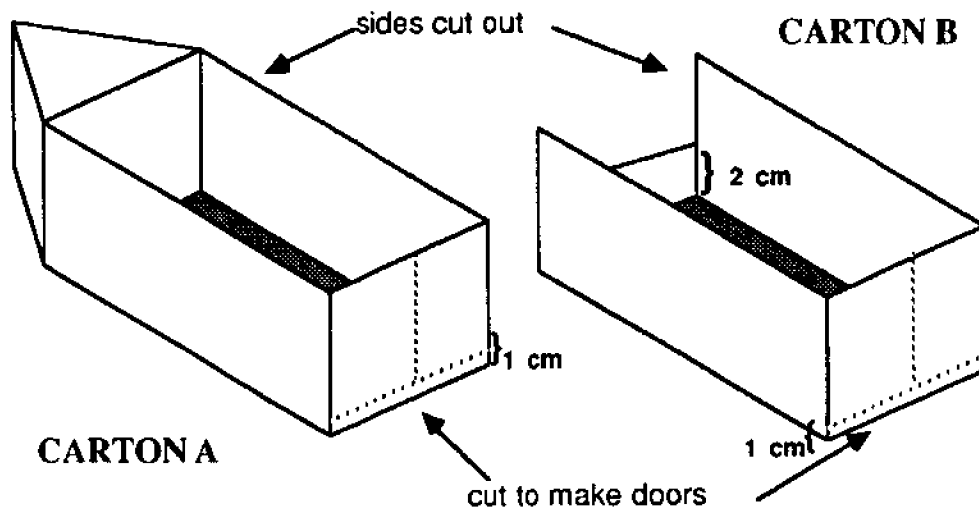

2. Connect the two cartons as shown below. Use modeling clay or heavy tape around the edges to make sure that water will not leak out where the cartons are joined together.

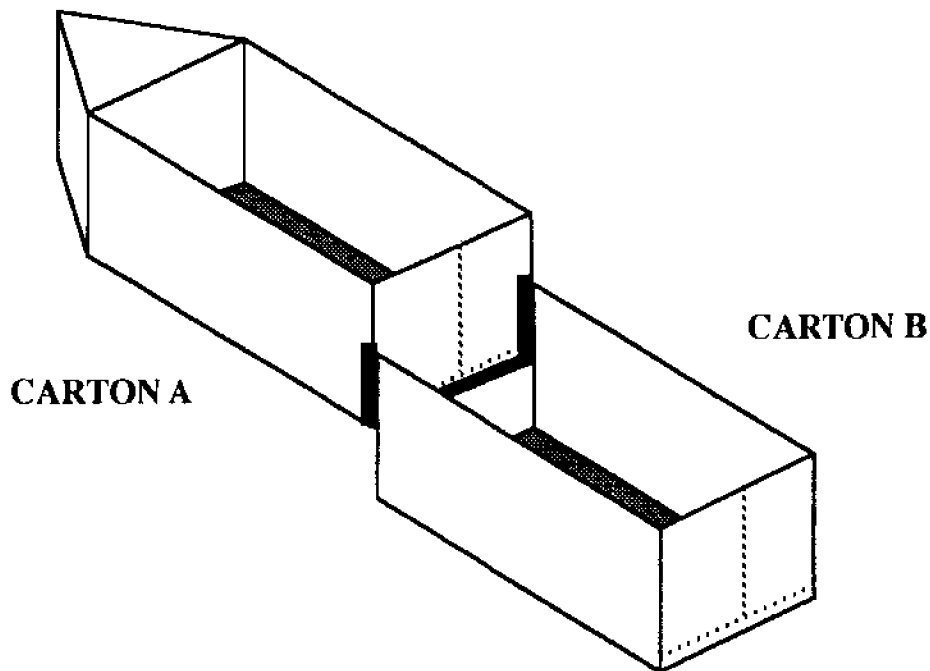

3. Add water to a sink or stream table to make an “ocean” about three centimeters deep. Put your model locks into the water with the open sides up and all doors tightly closed. You may need to use a bit of modeling clay or a large paper clip to keep the doors fully closed.
4. Pour water into carton B until it comes up to meet the bottom edge of Carton A. Then pour about five centimeters of water into Carton A. Place a small toy boat into Carton A. You may need to prop up the end of Carton A with a small block of wood or clay as shown.

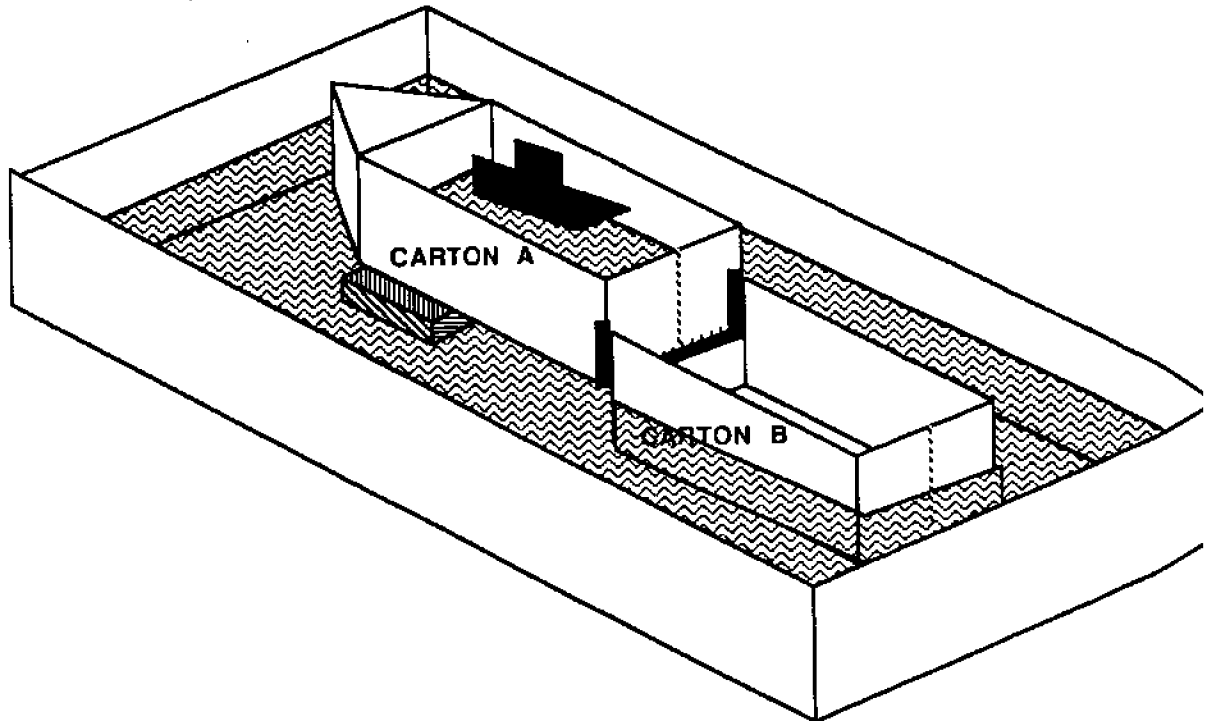

5. Slowly open the doors of Carton A to let the water levels in both cartons become the same. Move the boat downstream into Carton B.
6. Open the doors of Carton B slowly to let the water levels in Carton B and the “ocean” become the same. Move the boat downstream into the ocean.
7. To move the boat back upstream, open the doors to Carton B and move the boat in from the “ocean.” Close the doors to Carton B and open the doors to Carton A. Add water to Carton A until the water levels in Carton A and Carton B are the same. Move the boat into Carton A.

#### **FOR THOUGHT**

Where does the water for filling a real lock come from? When can a boat move into or out of a lock chamber?

---

# Clean Campaign

---

## Introduction

When Paddle was washed up onto a beach along Lake Michigan, he found himself sitting among old bottles, boxes, rusty metal, and other litter. Many beaches and other natural areas as well as highways and city streets are littered by careless people. Some of the litter can be recycled into useful things, and the rest belongs in proper waste containers.

## Objectives

When the students have completed this activity, they will be able to identify the types of litter and household trash that can be recycled. They will know proper disposal methods for other trash.

## Materials

Plastic garbage bags, old gloves, and old shoes.

## Terms to Know

**Recyclable materials**—materials like glass, paper, and aluminum, which can be broken down and processed to make new glass, paper, or aluminum without using new raw materials.

**Re-usable materials**—materials like glass bottles and plastics, which may be washed, sterilized, and used over and over without breaking down.

## Procedure

1. Introduce the idea of recycling by inviting a guest speaker from a local recycling firm. Or brainstorm with students to make a list of what kinds of materials can be re-used or recycled. Make a classroom display of recyclable and re-usable materials. Glass, newsprint, aluminum (cans or clean foil) are often recycled. Glass beverage containers (beer or soft drink bottles) are often re-used. Some states and provinces require people to pay a deposit when they buy re-usable or recyclable containers. This deposit is refunded when the empty containers are returned to stores or collection sites.
2. Organize a clean-up campaign in a local area. Give your campaign a catchy name and make flyers to deliver to people in the area encouraging them to participate in the clean-up effort. For example, "Clean Up Summers Street" has the initials CUSS. Flyers to people on the street could say, "It's enough to make you CUSS! Join the students at Summers School to help make our area beautiful again." Be sure to give the date, time, and meeting place for your campaign. Decorate the flyers with drawings of "BEFORE" and "AFTER" scenes.

3. Wear old shoes and old gloves to protect your feet and hands when you are gathering trash. Teams of two can share a garbage bag. Collect all the litter you find in your designated clean-up area.
4. Separate the re-usable and recyclable materials from the other litter you collected. Take these materials to a recycling center. Materials that cannot be re-used or recycled should be returned to their source if possible. Otherwise the remaining materials should be taken to a sanitary landfill or carefully placed in appropriate containers for pick-up by regular trash collectors. You may wish to make a display of how much litter you collected.

### Discussion Questions:

1. What kinds of materials did you find in the litter you collected? How much was recyclable or re-usable?
2. Where do you think these materials came from? Why would these types of litter be where you found them?
3. What problems might be caused by littering?
4. What problems might be caused by cleaning up litter? (*A major problem in many areas is the lack of available space to dispose of solid wastes.*)
5. What benefits are there in cleaning up litter and recycling? (*Some benefits include making the area more scenic, reducing the amount of raw materials used in manufacturing, and direct economic benefits to recyclers—most recycling centers pay for the materials that are brought in.*)
6. List three things you can do to help reduce the amount of trash you generate each day. How can you re-use or recycle trash at home?
7. Does your state or province require a deposit on beverage containers? What else might a government do to reduce waste?
8. If you were a fish, what would you think of humans?



---

# Forest Fires—Good and Bad

---

## Introduction

Paddle was trapped on an island during a forest fire. Every year fires destroy thousands of acres of forests. Sometimes the fires are caused by people, sometimes by other parts of nature. Although forest fires do much damage, they also do some good.

## Objectives

When they have completed this activity, students will be able to list some causes of forest fires and to describe both harmful and beneficial effects of forest fires.

## Materials

Paper, pencil or pen, markers or crayons.

## Procedure

1. Discuss how forest fires start. Some start from natural causes such as lightning. Some are started by people. Carelessness with campfires, matches, or cigarettes accidentally starts many fires. Sometimes fires are started deliberately. In many places, wooded areas are burned to clear land for farming. Firefighters set controlled fires around an area to keep forest fires from spreading outside that area.
2. Discuss the effects of forest fires. Chapter 19, *Forest Fire*, describes some of the harmful effects of forest fires. Trees and other plants are destroyed, animals are killed or lose their homes. Sometimes forest fires can be beneficial to ecosystems. The ashes in a burned area help fertilize the soil to make new plants grow better. The cones of the jack pine tree and some others do not open to release their seeds until they have been burned. Without forest fires, the jack pine would not survive.
3. Make a bulletin board about forest fires. Use both words and pictures to describe how fires start and what kinds of effects fires have on forests. Include measures you might take to prevent human-caused fires from occurring accidentally.

## Extension Activities

Invite a firefighter to talk to the class about fire safety in general. Discuss fire safety rules for school and home. Plan escape routes and conduct a fire drill at home or at school.

---

## Building a “Birchbark” Canoe

---

### Introduction

The Indians of North America were said to be the best canoe builders anywhere. They made some canoes by hollowing out logs (called “dugouts”). They made others by sewing together animals skins or pieces of tree bark over a wooden frame. Birchbark canoes were especially light and fast. To make one, the Indians sewed large pieces of bark together with thin strips of twisted bark or leather. Soaking the bark first made it easier to bend it into the proper shapes. They put pine pitch along the seams where the pieces overlapped to help make the canoes waterproof. We can build a simple model of a birchbark canoe using paper, yarn, and pipe cleaners.

### Objective

When students have completed this activity, they will be able to explain how a birchbark canoe is made.

### Materials

6" X 9" piece of oaktag and two yards of yarn or string for each student, pipe cleaners, scissors, yarn needles (with large eyes), rulers and pencils, pattern (page 112), crayons or markers and Scotch tape (optional).

### Procedure

1. Use pencil and ruler to copy the pattern onto your piece of oaktag. Number the pieces as they are numbered on the pattern.
2. Cut the oaktag apart along the solid lines you drew. Throw away the piece marked **DISCARD**.
3. If you wish, color your oaktag pieces to resemble tree bark.
4. Fold pieces 1, 2, and 3 along the dotted lines.
5. Fit the pieces together in your hand to get an idea of how the finished canoe will look. Piece 1 is the bottom of your canoe. Pieces 2 and 3 are the ends of your canoe, and pieces 4 and 5 are the sides. Notice that the end pieces are folded unevenly. Make sure that the longer parts of the end pieces are on **OPPOSITE** sides of the canoe. You may want to use small pieces of Scotch tape to hold the pieces in place while you sew them together.

6. Sew the pieces together. Begin at one end of the bottom piece and sew the end shut. Sew along one side of one end piece where it overlaps the bottom. Continue sewing along the side piece of the canoe where it overlaps the bottom. Join the second end piece where it overlaps the bottom. When you get to the end of the bottom piece, sew it shut, then continue sewing along the edge of the end piece where it overlaps the bottom. Sew the other side piece in place, then sew the remaining side of the first end piece and fasten the yarn securely. Now sew together the seams where the side and end pieces overlap. This completes the "skin" of the canoe.
7. Make a frame from pipe cleaners. Twist the ends of pipe cleaners together until you can make a loop that just fits inside the top of your canoe (it will be about 17 inches around). Attach three U-shaped pieces of pipe cleaner to this rim to make ribs that support the sides of the canoe (each rib piece will be about six inches long). Lower the frame into the "skin" of your canoe.

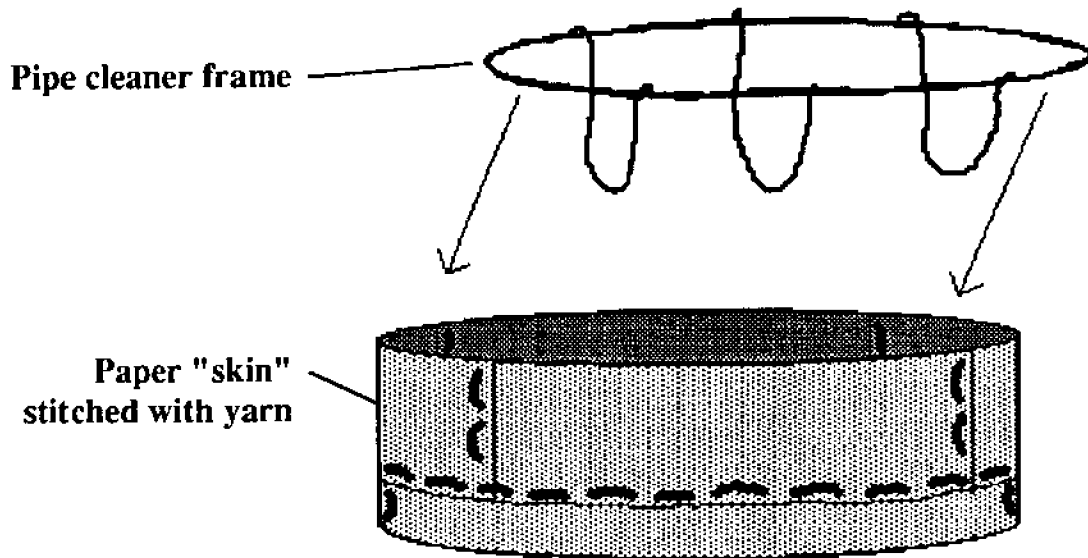

8. Use a whip stitch to attach the top edge of the "skin" of the canoe to the frame. Your canoe is complete!

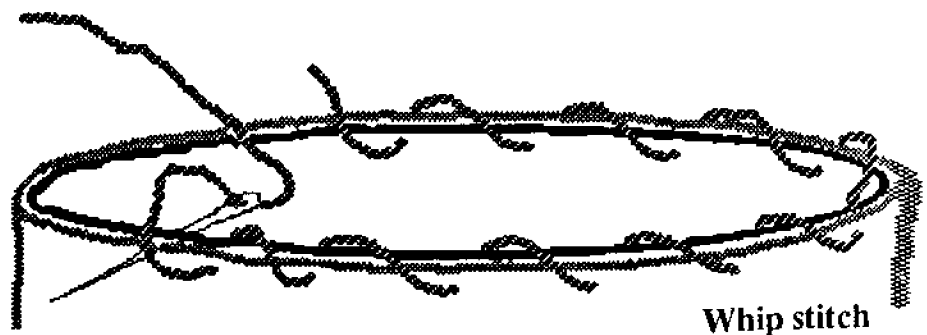

### Additional Information

Fortner, Rosanne W. and Victor J. Mayer, eds. *The Great Lake Erie: A Reference Text for Educators and Communicators*. Columbus, Ohio: The Ohio State University.

Rogers, Edward S. *Algonkians of the Eastern Woodlands*. Montreal: Royal Ontario Museum.

# Pattern for "Birchbark" Canoe

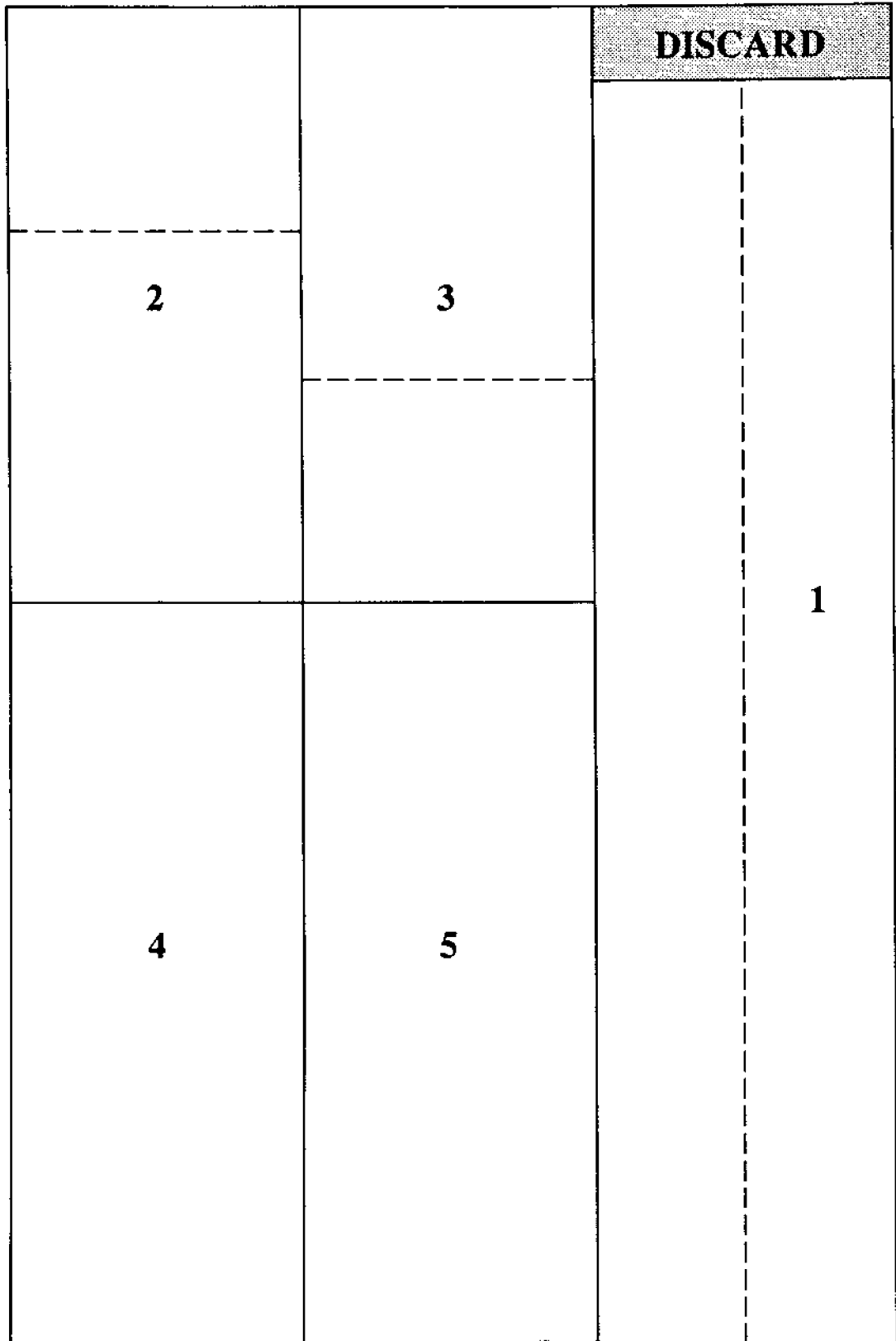

---

# Harbor Guides

---

## Introduction

Paddle travelled by motorboat through the St. Clair River, through Detroit's busy harbor, and through the Detroit River. To get through shallow waterways with many vessels coming and going, the boat used known sights and sounds as a guide to safe passage. In major harbors there are buoys that mark safe channels. The buoys stay in one place because they are anchored. They sometimes have lights, bells, whistles, or horns to make sure they are noticed even in fog or darkness.

## Objectives

When the students have completed this activity, they will be able to describe what it is like to depend on sounds to guide a ship through the darkness. They will note the importance of being able to depend on someone or something besides themselves to be safe on the water.

## Materials

Moveable tables and chairs or traffic cones; blindfolds.

## Procedure

1. Set up the room or playground with a simple maze made up of tables and chairs or traffic cones. This represents the channel of a harbor. Leave plenty of room for two people to pass each other in the maze.
2. Play the Harbor Guide game as follows: Each student selects a partner. One person in each pair is blindfolded and placed at the entrance to the harbor to represent a boat approaching in the night. All "sighted" partners represent buoys. One is positioned outside of each turn or intersection of the maze. Each buoy makes a different noise to guide the boats through the harbor. Each boat listens for the nearest buoy and turns away from it when it is very near. All buoys make their sound at regular intervals, but the boat is guided by the nearest sound. Boats themselves may make noises to warn other boats of their presence.
3. When the first group of boats has made it through the channel, partners switch places so all can experience the guidance by buoys.
4. When all boats have safely navigated the harbor, discuss the experience. In a real harbor, what obstacles might be present? How important is it for a boat captain to be alert to buoys and other sounds?

## Extension Activity

Look at a navigational chart. The legend shows the different symbols that represent buoys. How far apart are the buoys on the map? What kinds are shown? Even if the buoy makes no sound, how can it be a useful aid to navigation? (*Buoys are either red or green. The rule is that all red buoys are kept on the right when returning to port: Red-Right-Returning, and on the left going out to sea.*)

---

# Over the Falls!

---

## Introduction

As Paddle journeyed from Lake Erie into Lake Ontario, he was swept over Niagara Falls. Imagine how you would feel if you were Paddle, rushing toward this great waterfall, knowing that you could not avoid being carried over the edge and dropping into the rapids below.

## Objectives

When the students have completed this activity, they will be able to list the six basic questions a story should answer. They will write a story describing the feelings people might have when they are anticipating an important event.

## Materials

Paper, pencil or pen, markers or crayons.

## Procedure

1. Discuss with students what they expect to find out when they read any story. Six basic questions should be mentioned:
  - \* **WHO** is the story about?
  - \* **WHAT** is happening in the story?
  - \* **WHY** do these things happen?
  - \* **WHEN** is it happening?
  - \* **WHERE** does the story take place?
  - \* **HOW** is the problem solved? (How does the story end?)
2. Read Chapter 22, *Paddle Takes a Great Fall*. Discuss how Paddle might have felt as he saw Niagara Falls in the distance, as he neared the brink of the falls, as he was falling. Have you ever had similar feelings? In what situations? Were these feelings pleasant or unpleasant? Why?
3. Write a story that describes the feelings you or someone else experienced while waiting for an important event to happen. Or write about Paddle's feelings as he went over the falls. Remember the six questions your story should answer. Try to write the story so that your readers will feel the same way you did.
4. Draw a picture to illustrate your story. Make your picture express the feelings you described in your story. Think about drawing facial expressions and using colors to reflect the mood of your story.
5. Share the stories and drawings with the class. What mood does each drawing convey? Can you answer the six basic questions for each story?

# Great Lakes Bulk Carriers

Adapted from OEAGLS EP-013, *Shipping on the Great Lakes*

---

## Introduction

On the Great Lakes, all floating vessels are called boats, no matter how big they are. Large boats specifically adapted to carry heavy cargoes of unpackaged freight (**bulk cargo**) travel through the Great Lakes. These **bulk carriers** bring needed products into Great Lakes port cities and carry away products for use in other parts of the world. The Great Lakes are very important routes for the transportation of grain, coal, iron ore, and other products. Paddle passed many bulk carriers in busy ports on his way through the Great Lakes.

## Objectives

When students have completed this activity they will be able to name three major products transported on the Great Lakes and to identify the parts of a bulk carrier.

## Materials

**Great Lakes Cargo** worksheet (master on pages 117-118), markers or crayons, **Bulk Carrier** puzzle (master on pages 122-123) legal-size envelope for each student, 9 X 12 inch sheets of lightweight cardboard (optional).

## Terms to Know

**Bow**—front part of a boat

**Ballast**—weight (usually water or sand) used to balance a boat

**Bulk carrier**—large boat adapted for carrying heavy cargoes of loose material

**Bulkhead**—wall separating storage compartments in a boat

**Cargo**—products being carried

**Export**—to send a product to another place

**Forward**—toward the front part of a boat

**Funnel**—on a boat, the smokestack

**Hold**—part of a boat where cargo is stored (or held)

**Hatch**—covered opening into the hold for loading and unloading cargo

**Import**—to bring in a product from another place

**Rudder**—flat piece of metal located at the stern; used to steer a boat

**Stern**—the back part of a boat

**Wheelhouse**—room where the ship's steering wheel is located

## Procedure

1. Review Chapter 11, *Paddle Finds One End of Lake Superior*, Chapter 21, *Paddle Reaches Lake Erie*, and Chapter 22, *Paddle Takes a Great Fall*, for discussions of some Great Lakes products and descriptions of bulk carriers.

2. Complete the **Great Lakes Cargo** worksheet.
3. If you made a wall map to keep track of Paddle's progress (**Great Lakes Geography**, page 1) add tags to this map to indicate which products are imported into and exported from each of the cities on the worksheet.
4. Identify the parts of a bulk carrier. Use the key on page 121 to help you. Why is ballast used? What products might be carried in the cargo holds? Is the rudder forward or at the stern? How is the boat steered?
5. Color both pages of the **Bulk Carrier** puzzle (pages 122 and 123).
6. Cut the puzzle pages into pieces. (If you want to make the puzzle sturdier, glue the pages to lightweight cardboard before cutting the puzzle apart.) Put the pieces in an envelope to keep them together.
7. Trade your puzzle for a friend's and put it together.

#### **Extension Activities**

Make up a spelling and vocabulary quiz using the list of **Terms to Know**. Or play a matching game with two teams of students taking turns giving clues from the definitions and guessing the terms.



NAME \_\_\_\_\_

## Great Lakes Cargo worksheet

Here is a list of products which are transported into or out of some of the Great Lakes ports that Paddle visited. An **I** next to the product means it is **imported** into the city and an **E** means that it is **exported** from the city.

<b>THUNDER BAY, Ontario</b> iron ore - <b>E</b> grain - <b>E</b> coal - <b>I</b>	<b>TOLEDO, Ohio</b> iron ore - <b>I</b> grain - <b>E</b> coal - <b>E</b>	<b>CLEVELAND, Ohio</b> iron ore - <b>I</b> sand, gravel - <b>E</b> limestone - <b>I</b>
<b>CHICAGO, Illinois</b> grain - <b>E</b> iron ore - <b>I</b> coal - <b>I</b> limestone - <b>I</b>	<b>DETROIT, Michigan</b> iron ore - <b>I</b> coal - <b>I</b> limestone - <b>I</b> cement - <b>I</b>	<b>BUFFALO, New York</b> grain - <b>I</b> limestone - <b>E</b> coal - <b>E</b> iron ore - <b>I</b>

1. Which three products are transported most often? \_\_\_\_\_  
\_\_\_\_\_
2. Which of these is transported most? \_\_\_\_\_
3. Which city exports iron ore? \_\_\_\_\_
4. Which cities import iron ore? \_\_\_\_\_  
\_\_\_\_\_
5. On the maps on the next page, draw possible routes for the transportation of iron ore, coal, and grain. Use arrows to show the direction in which freighters would move. Remember, products move *from* a city of export *to* a city of import.

Transportation routes  
for  
iron ore

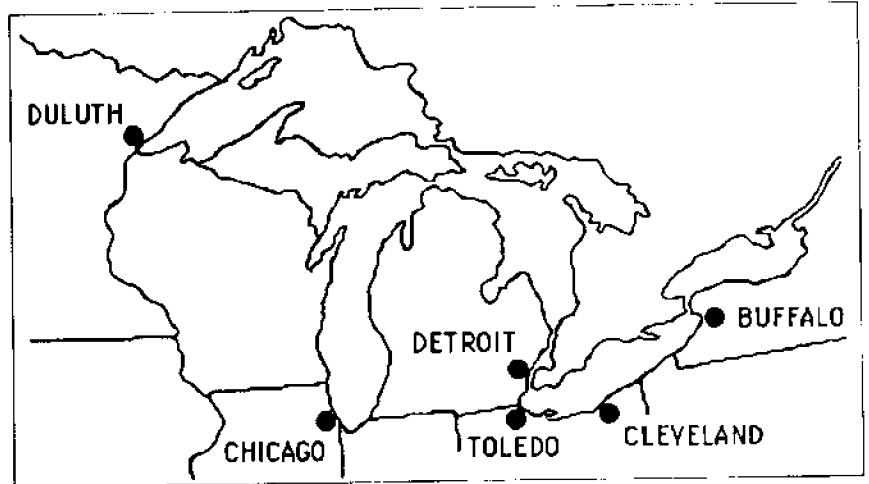

Transportation routes  
for  
coal

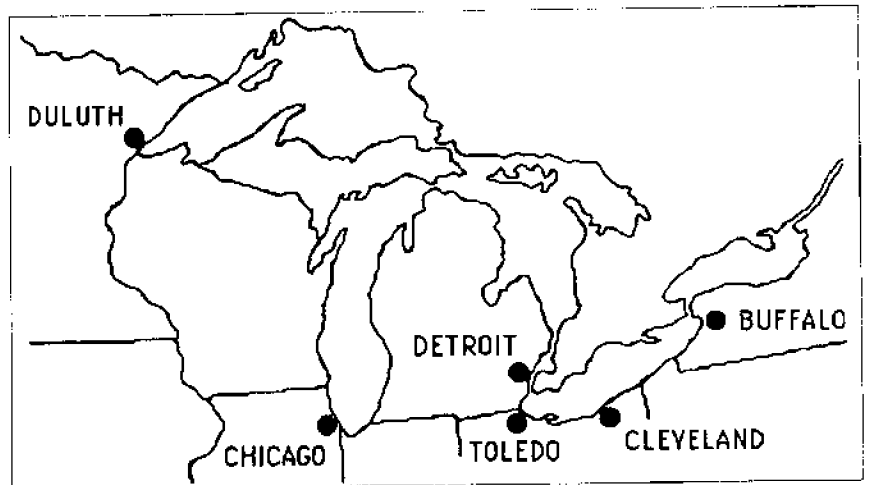

Transportation routes  
for  
grain

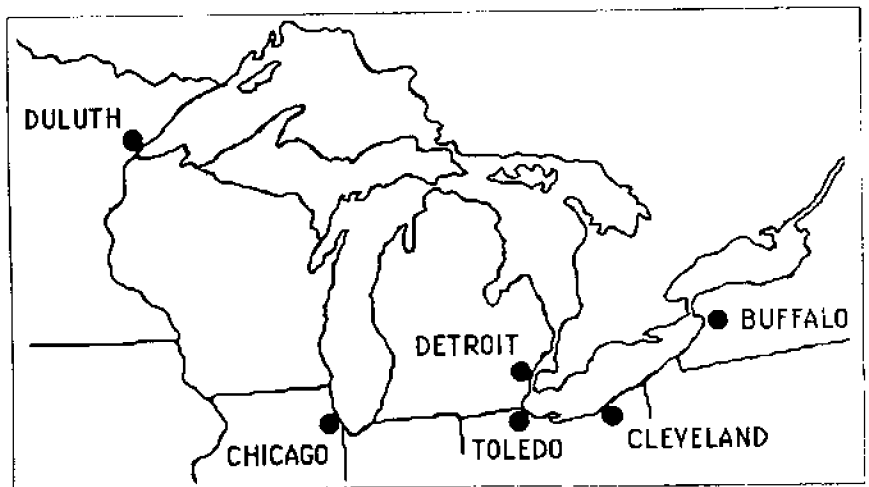

## ANSWER KEY—Great Lakes Cargo worksheet

Here is a list of products which are transported into or out of some of the Great Lakes ports that Paddle visited. An **I** next to the product means it is **imported** into the city and an **E** means that it is **exported** from the city.

<b>THUNDER BAY, Ontario</b> iron ore - E grain - E coal - I	<b>TOLEDO, Ohio</b> iron ore - I grain - E coal - E	<b>CLEVELAND, Ohio</b> iron ore - I sand, gravel - E limestone - I
<b>CHICAGO, Illinois</b> grain - E iron ore - I coal - I limestone - I	<b>DETROIT, Michigan</b> iron ore - I coal - I limestone - I cement - I	<b>BUFFALO, New York</b> grain - I limestone - E coal - E iron ore - I

1. Which three products are transported most often? *Iron ore, grain, coal*
2. Which of these is transported most? *Iron ore*
3. Which city exports iron ore? *Duluth, Minnesota*
4. Which cities import iron ore? *Chicago, Toledo, Detroit, Cleveland, and Buffalo (all cities shown except Duluth)*
5. On the maps on the next page, draw possible routes for the transportation of iron ore, coal, and grain. Use arrows to show the direction in which freighters would move. Remember, products move *from* a city of export *to* a city of import.

**ANSWER KEY—Great Lakes Cargo worksheet**

**Transportation routes  
for  
iron ore**

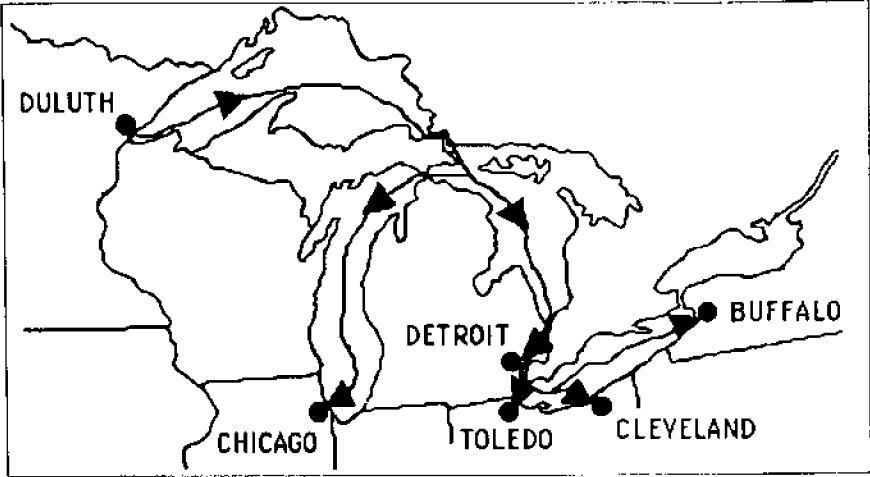

**Transportation routes  
for  
coal**

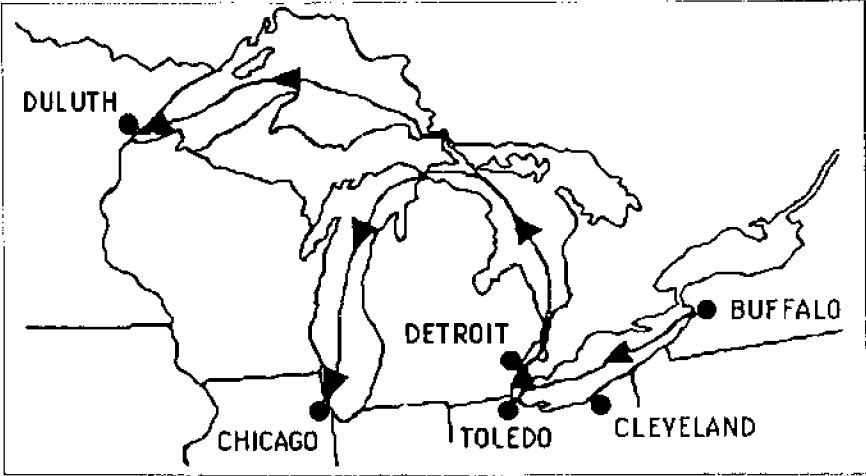

**Transportation routes  
for  
grain**

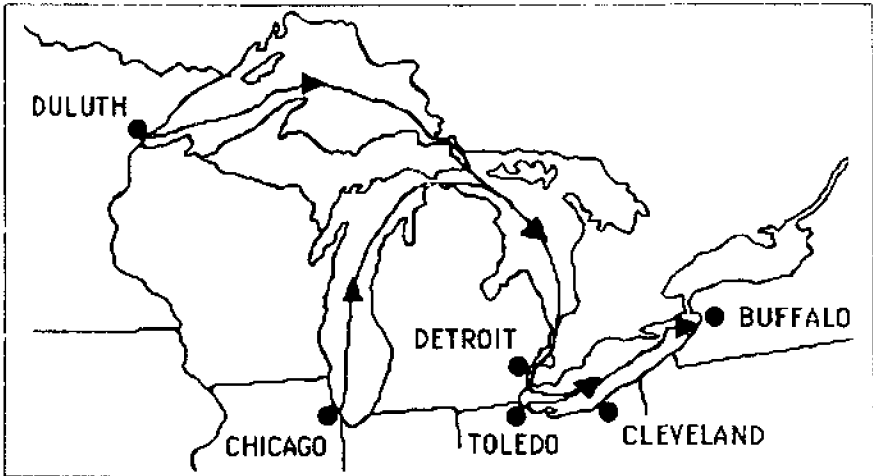

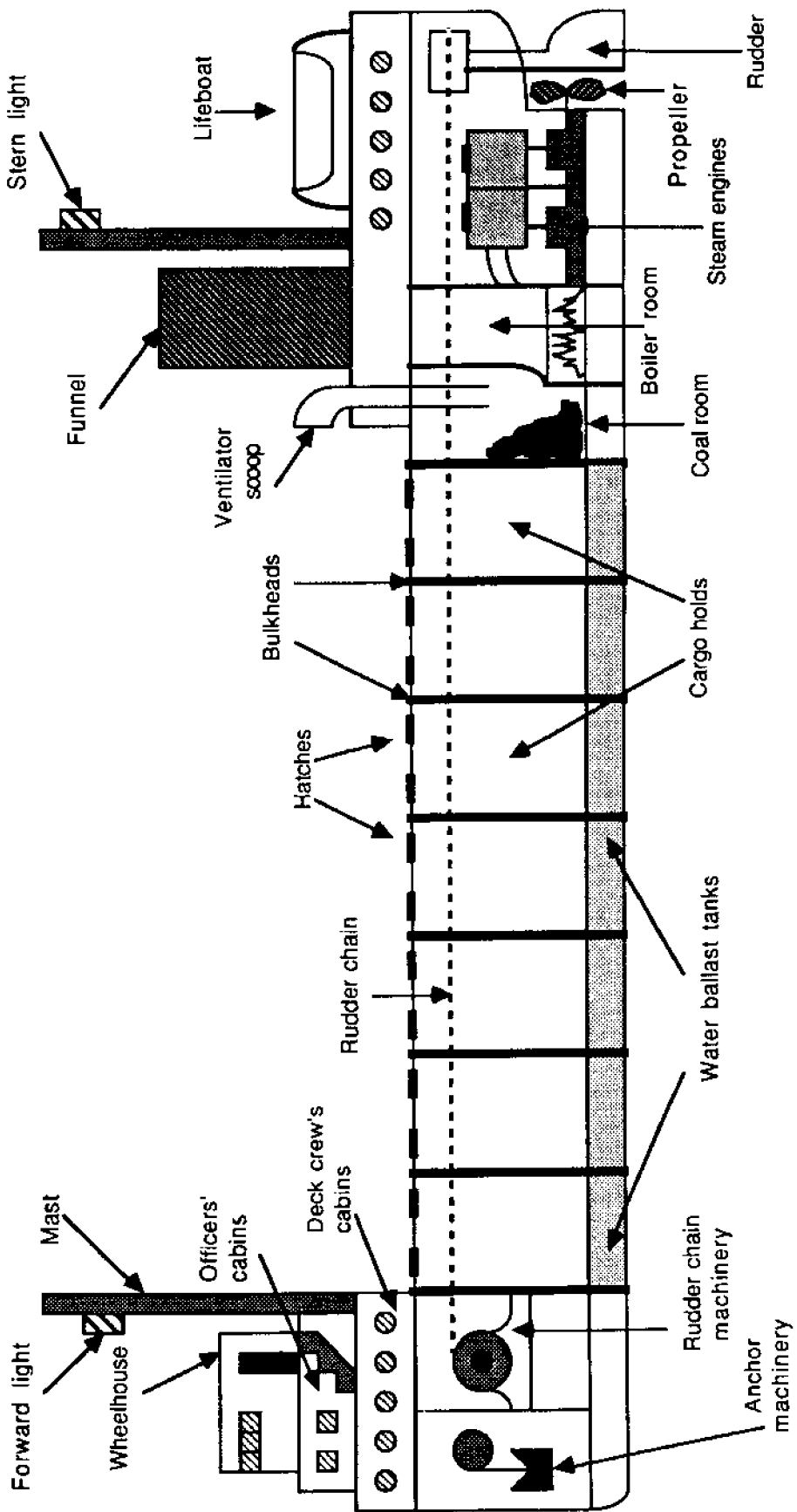

Great Lakes Bulk Carrier

# Great Lakes Bulk Carrier puzzle

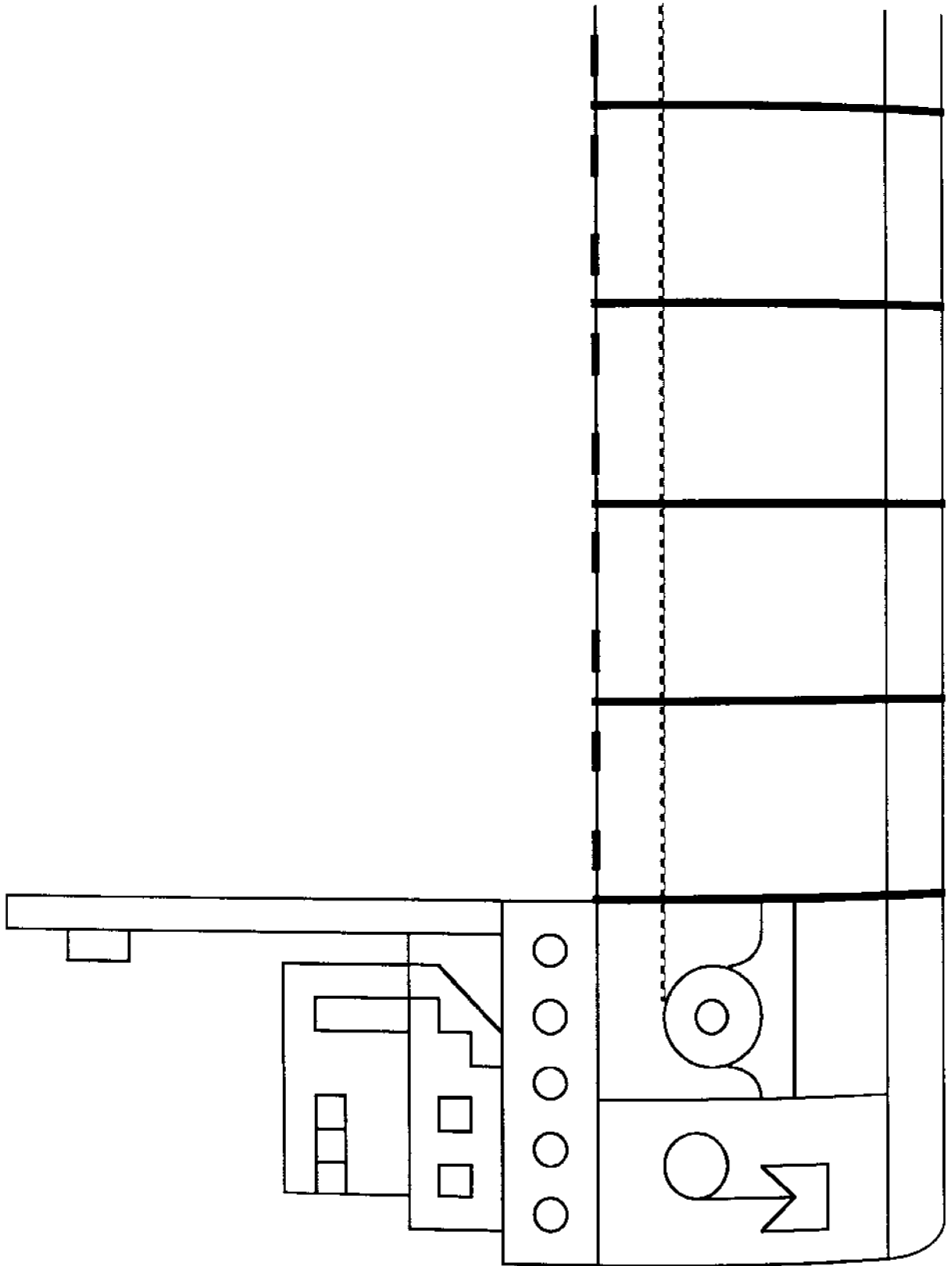

# Great Lakes Bulk Carrier puzzle

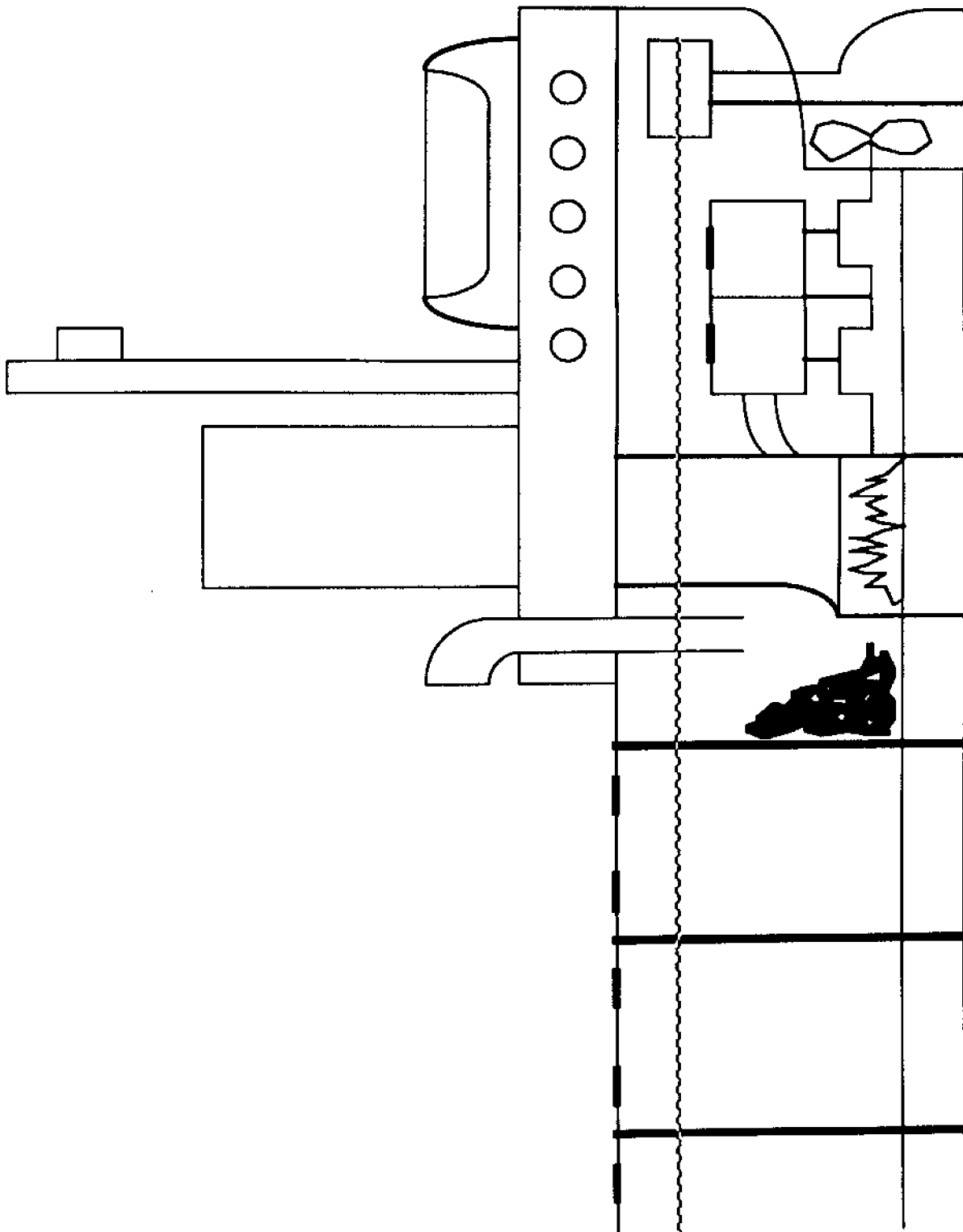

---

# Parlez-vous français?

---

## Introduction

Do you speak French? Many people in Canada do, because both English and French are official languages of Canada. Some of the most interesting stories of the human history of the Great Lakes are about the **voyageurs**, a word that means *travelers*. In the 1600s the voyageurs would paddle their large canoes day and night from Montreal to Grand Portage (Duluth, MN) and return. They were fur traders whose work was hard and dangerous. To keep the rhythm of the oars and prevent boredom, the 16 voyageurs in a canoe would sing songs.

## Objectives

When they have completed this activity, students will be able to say some French words and tell about the work of the French voyageurs on the Great Lakes.

## Materials

List of **Some French Words from Paddle's Adventures**, **French Word puzzle** (masters on pages 127-129), and **Voyageurs' song** (page 128).

## Procedure

1. Get from your teacher a copy of the list of French terms and their English translations. Look at the list of **French terms** while you cover up their English translations. Many French words are much like English ones. For which terms can you guess the meaning? Or write the French terms on the board and try to guess their meanings before writing the English translation.
2. Try to learn at least five of the French words that are new to you. Can you use them in a sentence?
3. From what you have read in *Paddle-to-the-Sea*, what do you think this sentence says? "Je suis Paddle-à-la-mer. Me remplacex dans l'eau, s'il vous plaît."
4. Use some of the French terms you have learned to complete the word puzzle.
5. Read the words of the **Voyageurs' song**. It tells about the life and work of the voyageurs. The voyageurs would have sung this song in French. Can you translate it? Older students in language classes may help.

## Extension Activity

Read about the adventures of the voyageurs. Discuss how they would get around Niagara Falls and other barriers in the Great Lakes. Talk to a person who has a boat on the Great Lakes and ask what it would be like to go through the lakes in a canoe.



## Some French Words from Paddle's Adventures

(French nouns are either masculine or feminine, and the article in front of a noun, *le* or *la*, tells which gender it is. *La* indicates a feminine noun, *le* indicates a masculine noun. If a noun begins with a vowel, the article will be shortened to *l'*. The plural of both *le* and *la* is *les*.)

les Grands Lacs ( <i>lay grahn lock</i> )	Great Lakes
Canada	Canada
les États-Unis ( <i>lays aytahs-yunee</i> )	United States
l'eau douce ( <i>low duce</i> )	fresh water
la mer ( <i>lah mare</i> )	sea, ocean
l'eau ( <i>low</i> )	water
le canoëiste ( <i>luh canoo-east</i> )	canoeist
le bateau ( <i>luh bah-toe</i> )	small boat
le navire ( <i>luh na-veer</i> )	ship
transatlantique ( <i>trans-atlanteek</i> )	transatlantic
voyager ( <i>voy-ah-ghay</i> )	to travel (verb)
la nuit ( <i>lah new-ee</i> )	night
l'orage ( <i>lorahge</i> )	storm
la tempête ( <i>lah tem-pet</i> )	storm
l'ouest ( <i>lou-est</i> )	west
l'est ( <i>lest</i> )	east
le nord ( <i>luh nor</i> )	north
le sud ( <i>luh sood</i> )	south
la rivière ( <i>lah ree-yyair</i> )	river
le fleuve ( <i>luh fluhv</i> )	major river
la glace ( <i>lah glahss</i> )	ice
geler ( <i>jhay-lay</i> )	to ice up (verb)
faire flotter ( <i>fair flow-tay</i> )	to float (verb)
le bûcheron ( <i>luh boo-sheer-on</i> )	lumberjack
bric-à-brac ( <i>brick-uh-brack</i> )	lumber

Do you know other French words to add to this list?

NAME \_\_\_\_\_

## French Word puzzle

The starting word is given. Work outward from that word to fill in words that have the right number of letters and can link with the letters you already have in place. For instance, there are five 3-letter words, but only one ends in C to match the blocks near the given word. Do not use the spaces or hyphens to fill in the puzzle blocks. None of the puzzle words is written backwards or diagonally.

**3 letters**

eau  
est  
lac  
mer  
sud

**5 letters**

douce  
geler  
glace  
orage  
ouest

**6 letters**

bateau  
navire  
Canada  
fleuve

**7 letters**

rivière  
tempête  
voyager

**9 letters**

bric-à-brac  
canoeiste  
États-unis

**8 letters**

bûcheron  
eau douce

**12 letters**

faire flotter

**4 letters**

nord  
nuit

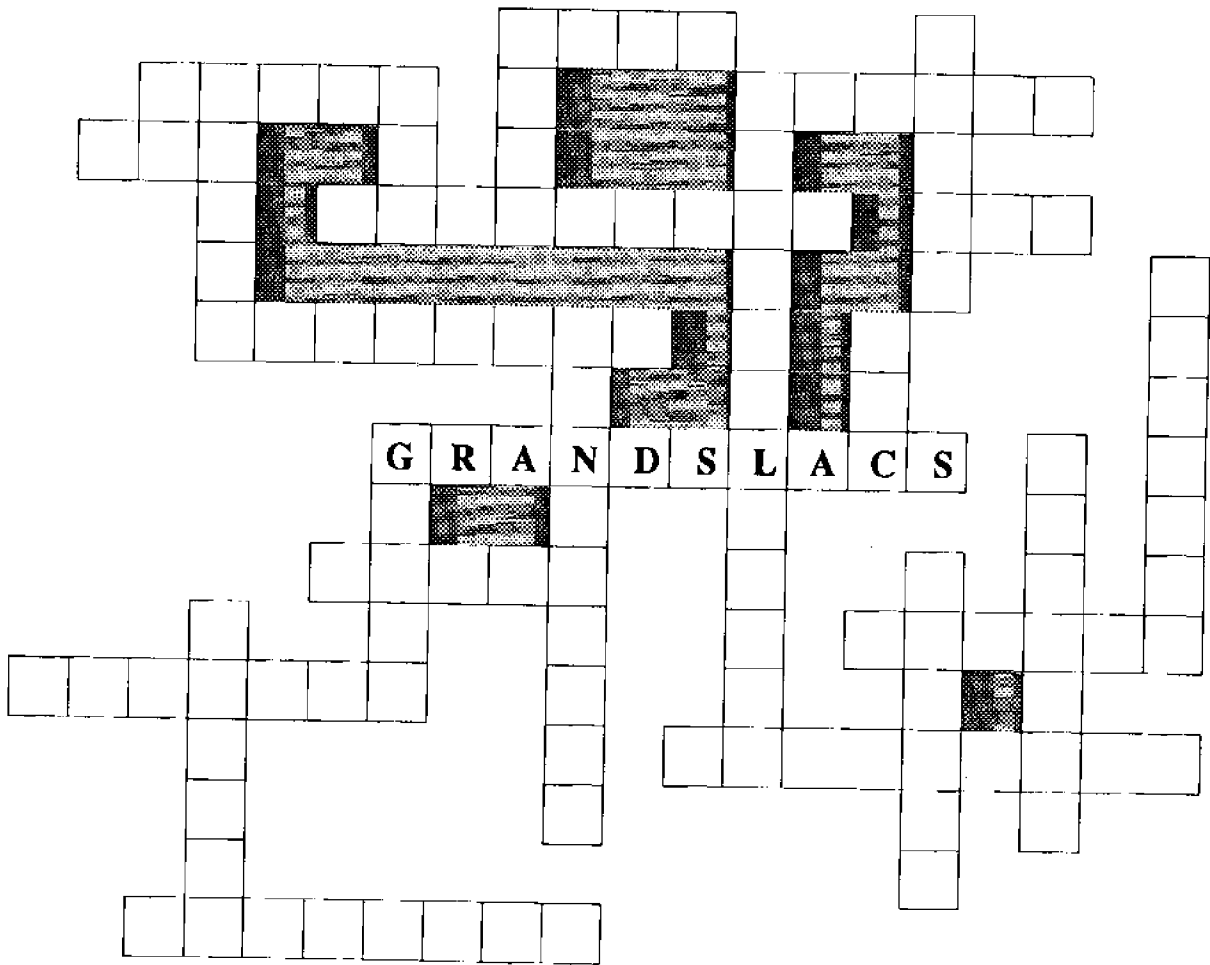

## ANSWER KEY—French Word puzzle

The starting word is given. Work outward from that word to fill in words that have the right number of letters and can link with the letters you already have in place. For instance, there are five 3-letter words, but only one ends in C to match the blocks near the given word. Do not use the spaces or hyphens to fill in the puzzle blocks. None of the puzzle words is written backwards or diagonally.

### 3 letters

eau  
est  
lac  
mer  
sud

### 5 letters

douce  
geler  
glace  
orage  
ouest

### 6 letters

bateau  
navire  
Canada  
fleuve

### 7 letters

rivière  
tempête  
voyager

### 9 letters

bric-à-brac  
canoeiste  
États-unis

### 8 letters

bûcheron  
eau douce

### 12 letters

faire flotter

### 4 letters

nord  
nuit

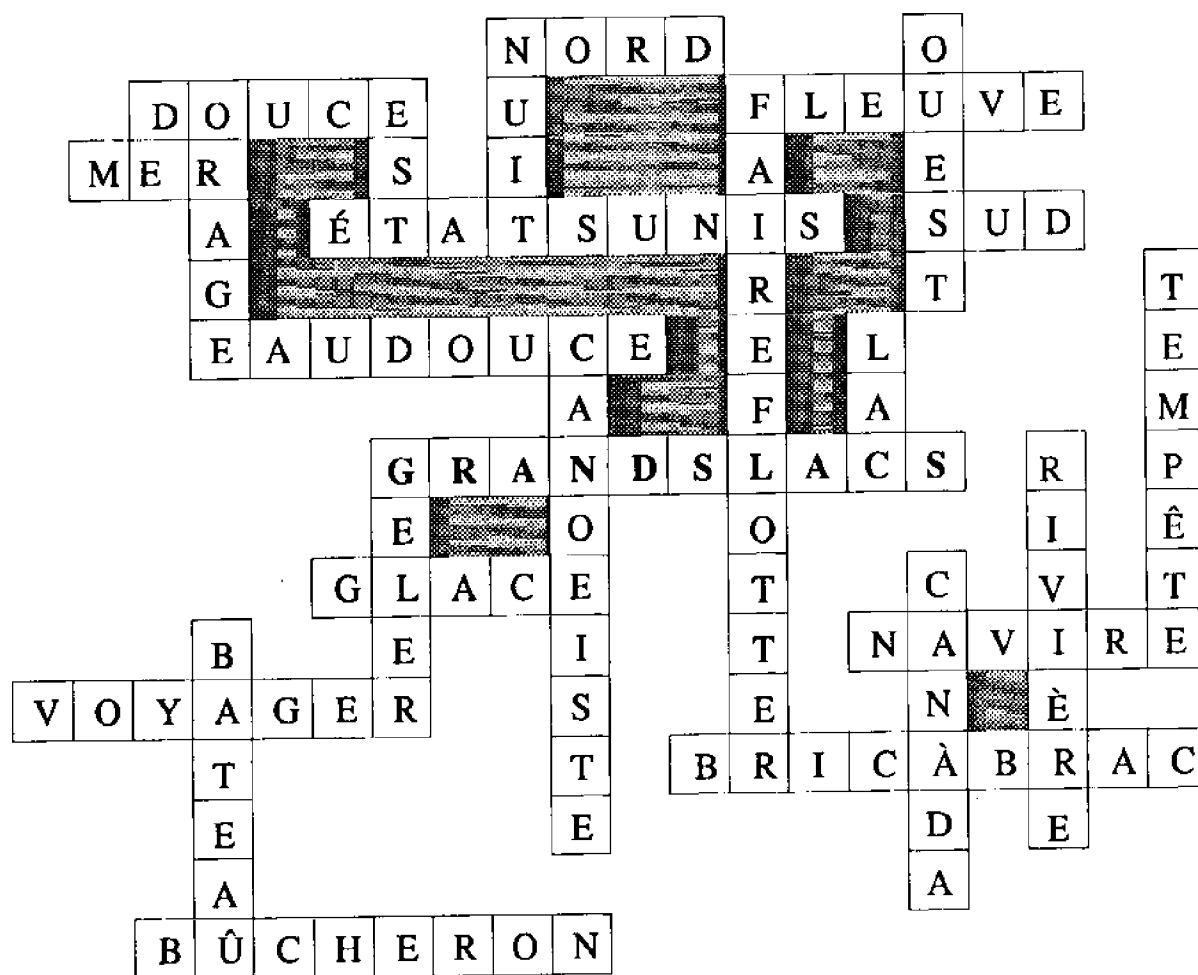



---

# Life in an Estuary

Adapted from OEAGLS EP-016, *The Estuary: A Special Place*

---

## Introduction

As Paddle travelled through Lake Superior, a wave tossed him across the beach into a marsh. Such wetland areas often form where a stream flows into a lake or the ocean. To most people, an estuary (pronounced es-chew-ary) is a place where fresh water meets the sea. In its larger meaning, an estuary is that part of the mouth of a stream in which the water level is influenced by the lake or sea into which the stream flows. The Great Lakes have freshwater estuaries.

## Objectives

When students have completed this activity, they will be able to describe the different plant communities that are found in an estuary and to explain how animals use these plant communities. They will be able to predict the effects of some human and environmental forces on conditions in an estuary.

## Materials

Green, blue, and brown crayons or colored pencils, **About Estuaries** background sheets (masters on pages 130 and 131), **Life in an Estuary** worksheet (master on page 132).

## Terms to Know

**Estuary**—that part of the mouth of a stream in which the water level is influenced by the lake or sea into which the stream flows

**Ecologists**—people who study the interrelationships between living things and their environment

**Submerged**—underwater

**Emergent**—sticking out of the water

**Sediment**—sand, soil, and other particles carried by a stream

## Procedure

1. Read **About Estuaries** background sheets with your class.
2. Refer to the background sheets and complete the worksheet, **Life in an Estuary**.

## Discussion Questions

1. What are the three different types of environments found in an estuary?  
What different types of plants are found in each?
2. Why do animals need plants? Why are so many different animals found in estuaries?
3. How do you think human activity could affect an estuary?

## Extension Activity

Play the **Food Chain Tag** game described on page 73 to find out more about the effects of pollutants on animals.

## About Estuaries background sheet

An **estuary** is that part of the mouth of a stream in which the water level is influenced by the lake or sea into which the stream flows. This means that as the water level in the lake or sea changes, so does the water level in the estuary. The amount of rainfall, tides, or human activities like a water diversion or dredging a channel can all affect the water level in an estuary.

In an estuary, some areas are almost always under water, some areas are almost always dry land, and some areas are between these two extremes. Each of these ecosystems has a set of plants that can survive best under the given conditions, and each set of plants has a special role to play in the estuary.

The diagram below represents a cross-section of a typical estuary. It shows examples of the types of plants found in each area of the estuary. **Ecologists** use a cross-section as a way to sample the populations of living things in a community. By naming and counting the plants along a cross-section, they get an idea of what the whole plant community is like, without counting and naming every organism in the whole community.

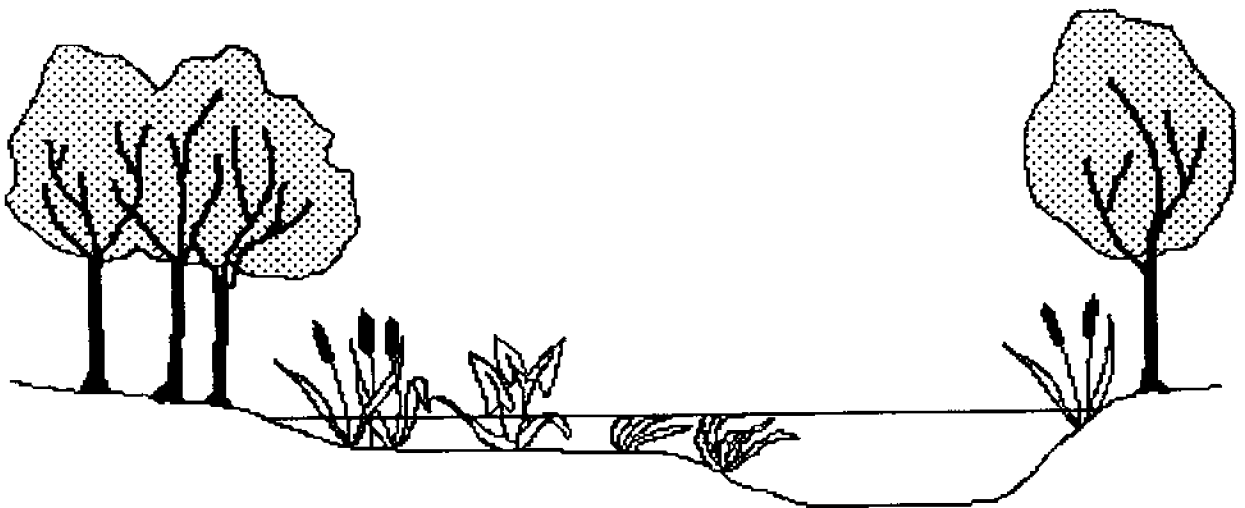

At the edge of the estuary are trees and shrubs rooted in fairly dry soil. Where the water is shallowest are **emergent** plants with their roots under water but their leaves sticking out of the water. In slightly deeper water are plants which are totally **submerged**. Only in the open stream channel are there no visible plants rooted in the stream bottom.

Each of the areas shown in the cross-section is able to support a group of animals. Suppose you watched this estuary for one week. On the next page is a list of the larger animals that you might see and the different activities you might observe. Remember, these plant communities and their animal visitors are only being *sampled*. There are many more organisms in the estuary than we have mentioned here.

The different types of environments within the estuary help many different animals meet their basic needs. Animals might come to the estuary to feed, drink, build nests, reproduce, or to find protection from enemies.

## Animals observed in a typical Great Lakes estuary during one week

Animal	How many	Area	Activity				
			Hunting	Eating	Reproducing	Hiding	Other
Raccoon	1	forest edge		x			washing food
White-tail deer	2	forest		x		x	drinking
Fox	1	forest	x	x			
Songbirds	21	forest edge		x	x		nesting
Black snake	1	forest	x			x	
American egret	8	forest			x		nesting
American egret	15	marsh	x	x			
Green heron	2	marsh	x	x			
Kingfisher	4	marsh	x	x	x		
Water snake	1	marsh	x	x			swimming
Seagull	4	marsh		x	x		
Carp	8	marsh		x	x		
Yellow perch	60	marsh		x	x		
Yellow perch	12	open water		x			swimming
Freshwater drum	9	marsh		x			
Gizzard shad	150	marsh				x	swimming
Gizzard shad	30	open water		x			
Clam	17	marsh mud		x	x		
Emerald shiner	42	open water		x			
Walleye	84	marsh		x	x		

The plants in an estuary tend to slow down the stream's flow. When water slows down, it cannot carry as much **sediment**, loose particles such as sand or soil. Therefore, much of the sediment carried by the stream sinks to the bottom of the shallow areas where plants are rooted in the water. Pollutants in the water may also settle out of the stream and be trapped in the estuary this way.

Pollutants can enter streams in many ways. Sometimes rain washes chemical fertilizers into streams from farmers' fields. Sometimes people dump wastes into streams accidentally or on purpose. Many pollutants are harmful to plant and animal life. Even a small amount of a pollutant might harm many living things.

NAME \_\_\_\_\_

## Life in an Estuary worksheet

Refer to the background sheets if you need help answering the following questions.

1. Use colored pencils to shade in the following features on the diagram below:

**Green:** Trees on the border of the estuary.

**Brown:** the marshy areas of the estuary.

**Blue:** the open stream channel.

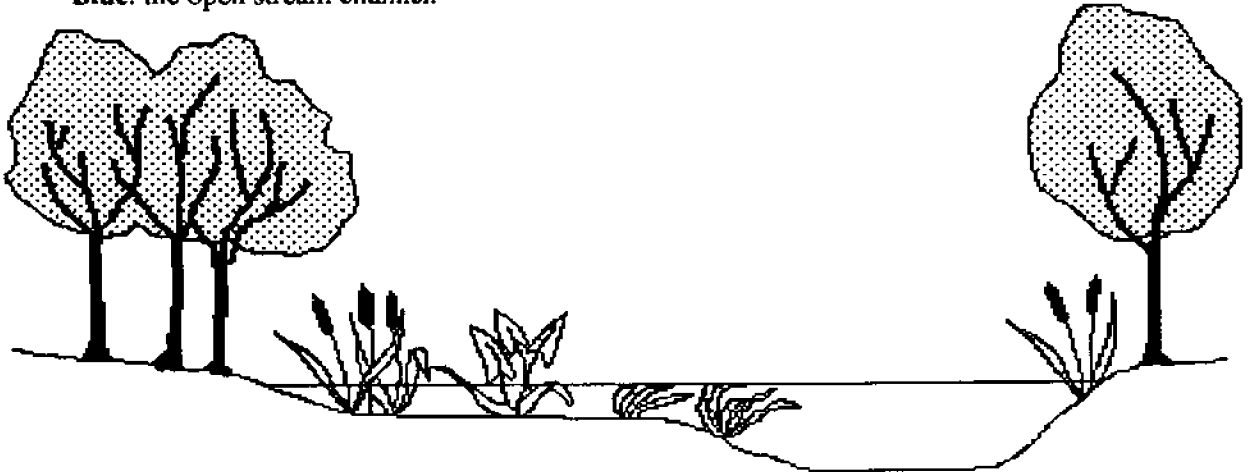

2. Which area on the diagram shows plants rooted in fairly dry soil?

\_\_\_\_\_

3. What do these plants provide for the animals that live nearby?

\_\_\_\_\_

4. Which area on the diagram has plants with emergent leaves?

\_\_\_\_\_

5. Which area has plants that are totally submerged? \_\_\_\_\_

6. In which part of the estuary would you find the largest number of animals?

\_\_\_\_\_

7. What are the two main activities carried on by animals in this area?

\_\_\_\_\_

8. Is the bottom of the estuary rocky or muddy? \_\_\_\_\_

Why do you think so? \_\_\_\_\_

9. How can human activity affect an estuary? \_\_\_\_\_

\_\_\_\_\_



## ANSWER KEY—Life in an Estuary worksheet

Refer to the background sheets if you need help answering the following questions.

1. Use colored pencils to shade in the following features on the diagram below:

**Green:** Trees on the border of the estuary.

**Brown:** the marshy areas of the estuary.

**Blue:** the open stream channel.

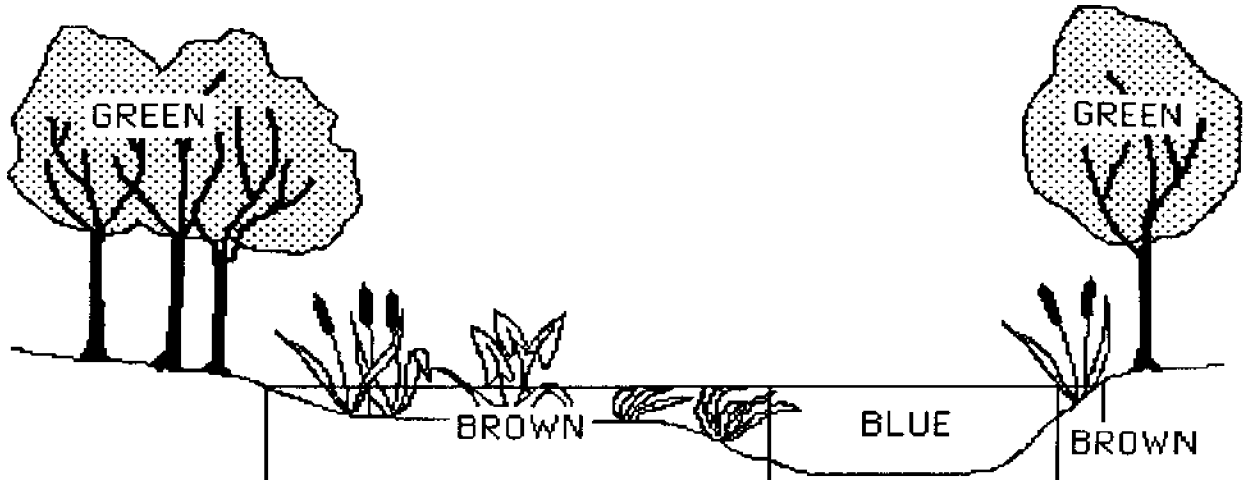

2. Which area on the diagram shows plants rooted in fairly dry soil?

*The edge of the estuary. Trees are in dry soil.*

3. What do these plants provide for the animals that live nearby?

*Food, nest sites or shelter, protection.*

4. Which area on the diagram has plants with emergent leaves?

*The marshy part of the estuary.*

5. Which area has plants that are totally submerged? *Most of the submerged plants are in the marsh.*

6. In which part of the estuary would you find the largest number of animals?

*In the marsh.*

7. What are the two main activities carried on by animals in this area?

*Most of the animals are feeding or reproducing.*

8. Is the bottom of the estuary rocky or muddy? *Muddy.*

Why do you think so? *Stream sediments settle to the bottom.*

9. How can human activity affect an estuary? *Change water levels by diverting water or dredging channels or introduce pollutants that may harm plants and animals.*

---

# Sharing Ecosystem Resources

Adapted from OEAGLS EP-022, *It's Everyone's Sea: Or Is It?*

---

## Introduction

When Paddle finally reached the sea, he was near the Grand Banks, a region famous as a fishing ground. Paddle was picked up by a French fishing boat. Fishermen from many countries besides Canada and the United States come to the Grand Banks. Many countries around the world are in conflict over using the resources of the sea. Fish, petroleum, and minerals are found along the coastlines and on the ocean floor. Do people own these resources? The United Nations Conference on the Law of the Sea has tried to establish rules that provide for a fair division of ocean resources. Chief Seattle voiced another view: that no one owns the earth's resources.

## Objectives

When students have completed this activity, they will be able to describe the main provisions of the third Law of the Sea conference and to identify the interests nations have in using the sea. They will be able to discuss Chief Seattle's view of "ownership" of resources.

## Materials

**Categories of Nations** background sheet (master on page 136), **Role-playing** cards (masters on pages 137-145), globe or map of the world (optional), **The Challenge of Chief Seattle** (pages 146-148).

## NOTE

At least two class periods are needed to complete this activity. Help mediate the procedure by setting time limits for group discussion, calling for presentation of group statements, and asking for the final vote.

## Procedure

1. Read and discuss the **Categories of Nations** background information.
2. To simulate a Law of the Sea conference, divide the class into groups, representing the countries described in the role-playing cards. Use either Canada *or* the U.S. as one group, but not both. Allow time for the groups to read and discuss their role-playing information. Where is each country located? Into what category or categories does each country fit? A globe or map of the world is helpful as a reference.
3. Have each group elect an ambassador who will present the group's viewpoint to the conference.
4. Your Law of the Sea conference will consider four actions. Write these on the board or post them where all students can see them during the conference. The actions to be considered are:

- I. Establish a 12-mile Territorial Zone in which the customs, sanitary, and financial laws of the country would be enforced.
  - II. Establish an Exclusive Economic Zone, 200 miles wide, in which the nation would have control over fish and mineral resources in the water and the seabed. Other nations would still have freedom to sail through or fly over these areas.
  - III. Establish an International Seabed Authority, which would explore and develop the area beyond the Exclusive Economic Zone. Resources obtained by this Authority would be shared with countries that do not border on the ocean.
  - IV. Establish a Pollution Prevention Tribunal, which would act to prevent, reduce, and control pollution of the oceans.
5. Each group (country) will take an official stand on each of the proposed actions. Groups should discuss the four actions and decide which will be opposed and which supported based on the information in their role-playing cards. Each group should write a position paper for its country stating why it supports or opposes each action.
  6. Ambassadors will present the position papers to the conference (the entire class). Which issues (if any) do all eight countries support? Which issues (if any) do all oppose? About which issues do countries disagree? Why? Were the views of Chief Seattle expressed by any?
  7. Take a vote on each proposal. An action may not pass unless all groups are in favor of it. If the vote on an action is not unanimous, discuss the issue. Try to persuade other groups to agree. Why might different groups disagree on these issues? After discussion, take another vote. Which of the actions did your conference pass? Which were defeated?

### Discussion Questions

1. What are the basic interests that countries have in the oceans? (*Most countries have economic interests in fish and/or mineral resources, transportation needs, and military (defense) interests.*)
2. Why must all actions taken by a Law of the Sea conference be passed unanimously? (*It would be difficult to enforce a law of the sea unless all countries accepted it.*)

---

## Categories of Nations

---

Each of the world's countries can be classified according to its level of development, types of industry, and geography, into one or more of the following categories:

**STRAITS COUNTRIES** are located next to a narrow waterway connecting bodies of water with access to the sea. There are many straits in the world that are less than 24 miles wide. A 12-mile Territorial Zone would limit the right of other countries to pass through these straits. Spain, which borders on the Straits of Gibraltar, is the example of a straits country used in this activity. Can you find another straits country on the map?

**FISHING COUNTRIES** include countries with important coastal fisheries and those with fishing fleets that travel to distant areas. The USSR, USA, Canada, Iceland, and Spain can all be considered fishing states. All except the USSR have extensive coastal fishing areas; the USSR sends its fishing fleet around the world.

**ISLAND COUNTRIES** like Bermuda would control large areas of the ocean if a 200-mile Exclusive Economic Zone were enforced. Small nations would thus be in a position to control large amounts of very valuable resources.

**MARITIME COUNTRIES** have large fleets of commercial and naval ships. Canada, the USSR, and the USA are examples of maritime countries. They are concerned about the right of free passage for their ships, especially through narrow straits.

**LIMITED SHELF COUNTRIES** have narrow or short continental shelves. These areas of comparatively shallow water contain many resources. Countries like Yugoslavia and Nigeria, which have limited shelf area, could consider themselves at a disadvantage because they have less access to valuable resources.

**LANDLOCKED COUNTRIES** have no coastline. For this activity, Bolivia is an example of a landlocked country. Under current laws, these countries have no rights to coastal resources. A Seabed Authority that would share ocean resources among all nations would be favorable to these countries.

**DEVELOPING COUNTRIES** do not have much industry and frequently lack natural resources. Nigeria and Yugoslavia are examples of developing countries. These countries may be in need of the sea's fish and mineral resources, but they do not yet have the technology to get them for themselves.

**DEVELOPED COUNTRIES** have strong industrial bases and strong economies. Countries like the USA, Canada, and the USSR have the technology to find and extract ocean resources, and they also have a large share of the world's wealth.

## THE UNITED STATES OF AMERICA

The United States of America has been nicknamed "the melting pot of the world" because of the wide variety of nationalities, religions, climates, natural resources, and agricultural and manufacturing products. Education from age 6 to 16 is compulsory. Most Americans graduate from high school or vocational school and many attend colleges and universities. In 1983, the average per capita income was \$11,675; one of the highest in the world.

**AREA:** 3,615,122 square miles (4th largest country in the world)

**POPULATION:** 226,545,805 (1980 census) (4th highest population in the world).  
Literacy Rate = 99%.

Seventy-four percent of the population lives in metropolitan areas situated along coastlines or major waterways. The United States is the world's leading manufacturing country. Machinery, food products, fabricated metal products, primary metals, printed publications, paper products, and instruments are the leading products.

Twenty-six percent of the population lives in rural areas. There, farming is the leading occupation. The United States has fertile soil. The use of modern machines and technology has greatly improved the quantity and quality of farm products. Beef cattle, corn, dairy products, eggs, hogs, poultry, soy beans, tobacco, and wheat are produced in great quantities.

The United States has many natural resources. Water supplies provide hydroelectric power, irrigation for agriculture, and transportation for industrial products. Leading minerals include coal, iron ore, lead, limestone, natural gas, oil, phosphorus, potash, uranium, and zinc. Due to low or absent supplies, antimony, asbestos, bauxite, chromite, cobalt, copper, diamonds, iron ore, magnesium, mica, nickel, tin, titanium, and uranium must be imported. Because of its high rate of energy consumption, the United States must now import almost half of its oil, most of which comes from overseas.

The imported products come from many countries. The United States trades with every nation in the world. Over 800 vessels carrying 1,000 gross tons or more make up the American merchant fleet; however, 90 percent of America's shipping is done with vessels that are registered with foreign governments.

Along the Atlantic and Pacific Oceans three and one half million metric tons of fish and other seafood are caught annually. The chief fishing states include Florida, Massachusetts, Maine, North Carolina, and Oregon. Cod, haddock, herring, and mackerel are caught along the New England coast. Menhaden fish and shrimp are the major fish catches in the South Atlantic and Gulf Coast, and salmon and tuna are caught along the Pacific Coast.

About 2,135,900 people are enlisted in the Army, Navy, Air Force, Marine Corps, and Coast Guard and the defense budget is over \$100,000,000,000 (about 7 percent of the Gross National Product). The Navy employs about 564,800 men and women at American naval bases and also at bases located in Newfoundland, Bermuda, Bahamas, Jamaica, St. Lucia, Trinidad, Antigua, and British Guyana.

The United States falls into several categories of countries: it is next to several straits including the Bering Strait, it is a major fishing nation and maritime nation, and it is developed.

**Information Source:** World Book Almanac of Facts, 1986  
Countries of the World and Their Leaders, 1986

## CANADA

Canada is the second largest country in the world. It borders on the Atlantic, Pacific, and Arctic Oceans, and its largest cities and industrial areas are located along the Great Lakes and St. Lawrence River. There are two official languages in Canada: English and French. About 45 percent of Canadians are of British descent, and about 29 percent are of French ancestry. In 1980 the per capita income was greater than \$10,000.

**AREA:** 3,845,274 sq mi (9,959,219 sq km); second largest country in the world.

**POPULATION:** 25,142,000 (in 1984); 85% within the southern 200 mi (320 km). At age 6, children begin an eight-year elementary school and then at about age 14 almost all enter a regular four or five year secondary school.

Over 3/4 of Canadians live in cities and towns. The largest cities, Quebec City and Toronto, are on the Great Lakes/St. Lawrence River. The main economic fields are service industries and manufacturing. Canada's gross national product ranks among the top ten in the world. Service industries like hospitals, schools, restaurants, data processing services, and banks employ about 2/3 of Canada's workers. Manufacturing consists mainly of food processing, transportation equipment, and newsprint, all of which depend on the abundant natural resources of the country.

Canada is rich in natural resources. The fish, fur-bearing animals, and forests that first brought settlers to Canada continue to be important to the economy. Canada leads the world in the production of newsprint, is one of the world's leading wheat producers, and is third in the world in generating hydroelectricity. Canada is the world's biggest exporter of minerals, leading the world in production of nickel and zinc. It ranks second in the world in asbestos, molybdenum, potash, and uranium. More than half of Canada's income from minerals is based on petroleum and natural gas. Coal, copper, gold, iron ore, lead, magnesium, silver, titanium, and tungsten are also mined.

The fishing industry is one of Canada's oldest industries. The Grand Banks area on the Atlantic coast is among the world's best fishing grounds: lobster, shellfish, cod, and herring are abundant. On the Pacific coast, salmon is the main product.

Most of Canada's trade is with the U.S. and Japan. Canada has its own supplies of fossil fuels. Petroleum use is decreasing and natural gas is becoming more popular as a fuel because it is plentiful and relatively nonpolluting. Hydroelectric and nuclear plants supply 28 percent of Canada's energy needs.

Since 1968, Canada's air, ground, and naval armed services have been merged into one military force called the Canadian Armed Forces.

Canada, like the U.S., falls into several categories of countries: it is a major fishing and maritime nation, and it is developed.

**Information source:** World Book Encyclopedia, 1983  
World Almanac and Book of Facts, 1986  
The New Encyclopedia Britannica, 1987

## UNION OF SOVIET SOCIALIST REPUBLICS "RUSSIA"

Russia is the largest country in the world. It borders three major oceans: Atlantic, Pacific, and Arctic. However, its only ports lie in high northern latitudes and are, therefore, closed by ice during part of the year.

Russia was the first country to develop a communist government and today has alliances with most other communist countries.

A governing council rules over 15 republics that make up the USSR. Each is almost like a separate country since languages, customs, and traditions vary greatly among the republics.

**AREA:** 8,549,500 square miles (3 times larger than the United States, excluding Alaska)

**POPULATION:** In 1980 was 265.5 million. It ranks third in world population and has a Literacy Rate = 99.8%.

Russia is a developed country with an excellent educational system enrolling 55 million full-time students. Sixty-four percent of the population lives in cities and is employed by business and industry. Thirty-six percent of the Russian people live in the country, most on farms. A few farms are privately owned and operated, while most are state owned and operated by 5 to 10 families apiece. The per capita income in 1980 was approximately \$4,550 U.S. dollars.

Russia produces the following agricultural products: barley, corn, flax, rye, cotton, oats, potatoes, sugar beets, and livestock. Russia's leading natural resources are bauxite, coal, copper, gold, iron ore, lead, and forestry products. Russia is the largest oil producing nation in the world. Besides oil, hydroelectric power and coal are the major energy sources. It also has one of the world's largest fishing fleets. Fish provide a major source of protein in the Russian diet.

Russia exports iron, steel, lumber, machinery, and petroleum. Since Russia is almost self-sufficient in most materials, only a few goods are imported—industrial equipment and consumer goods. Russia's leading trading partners are Czechoslovakia, Japan, Italy, Germany, Poland, Bulgaria, Hungary, Romania, Cuba, and the United States. Over 7,000 vessels make up the Russian merchant fleet. The most important merchant sea ports are at Vosochny in far eastern Russia, Girgorevsky on the Black Sea, Ventspils at Latvia, and Murmansk and Archangel, used for Arctic traffic.

It has the largest armed forces in the world, employing over 3,375,000 persons. The defense budget is approximately 15 percent of the Gross National Product. Russia's navy is steadily expanding and progressively modernizing with over 500,000 officers and men. Naval ports are located in Nikolaiev and the Sevastopol on the Black Sea, Molotovsk on the White Sea, Komsomolsk on the Amur River, and Leningrad.

Russia is in several categories: it is next to several straits, including the Bering Strait; it is a fishing country with a worldwide fleet; a maritime country, and developed.

**Information Source:** World Almanac Book of Facts, 1986  
Countries of the World and Their Leaders, 1986

## SPAIN

Spain occupies 5/6 of the Iberian Peninsula, with the remaining occupied by Portugal. It boasts 3,340 miles of coastlines bordering both the Mediterranean Sea to the south and the Atlantic Ocean to the north and west. The climate is sunny and dry. The high central plateau region has hot summers and cold winters. Along the coast, climatic conditions are not as severe.

**AREA:** 195,988 square miles (slightly larger than California)

**POPULATION:** 38,629,000 (est, 1985) (about 50 percent larger than California).  
**Literacy Rate = 97%.**

It has grown to become a modern, industrial country. Today, half of Spain's population lives in cities, dwelling mostly in apartments. The per capita income in 1979 was \$5,500 U.S. dollars. Most of the working force is employed in industry, farming, or fishing. Spain is one of the world's leading producers of automobiles and ships. In addition, cement, chemical products, clothing, shoes, cork products, and steel are also major manufactured items. Most of the industrial and energy resources must be imported since Spain lacks raw materials. A few minerals such as coal, lignite, iron ore, zinc ore, and lead are mined for industrial use or exported.

Farm production in most regions is low due to poor soil, dry climate, and inferior farming techniques. Although livestock, cereals, vegetables, grapes, oranges, tobacco, honey, and sugar cane are major farm products, much food must still be imported.

Spain is a leading fishing nation, catching over 1.2 million metric tons of fish each year, chiefly anchovies, codfish, hake, sardines, and tuna. The Spanish fishing fleet includes 16,854 vessels. The fish come primarily from the water off the northern coast of Spain. The merchant shipping fleet includes 3,040 vessels carrying over 3 million passengers and 49 million tons of cargo annually to other parts of the world.

Spain has approximately 280,000 men in the armed forces. The Spanish fleet is undergoing modernization.

Because of its position at the mouth of the Mediterranean, Spain would be considered a "straits" country. It is also a fishing nation and is becoming a developed country.

**Information Source:** World Almanac Book of Facts, 1986



## YUGOSLAVIA

Yugoslavia borders the Adriatic Sea in southeastern Europe. Its population is a mixture of many nationality groups with different cultures, religions, and languages. Much of the area is mountainous. Along the coast, over 700 islands and the indented coastline provide many excellent natural harbors. In northcentral Yugoslavia, the Danube River runs through the Pannonian Plains region, which is flat with rich soils, making this region the chief farming area. The climate along the coast is mild; however, more extreme climatic conditions occur inland.

**AREA:** 98,766 square miles (a little larger than Oregon)

**POPULATION:** 22,412,000 (1982 census) (ten times greater than Oregon).

Literacy Rate = 90%. Almost all attend Primary School.

The Yugoslavian standard of living is high. Most families own a car, television set, and other luxury items. They travel freely to other countries. In most cases, both the husband and wife hold full-time jobs. The per capita income is \$3,109 U.S. dollars.

About 35 percent of the land is devoted to agriculture, providing high yields of corn, sugar beets, wheat, barley, oats, potatoes, tobacco, grapes, olives, plums, cattle, and sheep. Forests cover 35 percent of the land and forest products are a major export.

Mineral resources include bauxite, chromite, coal, copper, iron, lead, mercury, natural gas, petroleum, and zinc. Yugoslavia trades mostly with Italy, Germany, the Soviet Union, and the United States. The major exports are forest products, livestock, machinery, metals, plastics, and textiles. The chief imports include coal, crude oil, machinery, metals, plastics, and textiles. The Yugoslavia shipping fleet consists of 432 vessels. Half of Yugoslavia's energy comes from hydroelectric power. Coal is also widely used and a new nuclear power plant is near completion.

The principal product from the Adriatic Sea is fish. Yugoslavia owns more than 200 motorized fishing vessels and over 1,700 sailing and rowing fishing vessels. Fish catch in 1981 was 71,000 metric tons.

The Yugoslavian armed forces consist of about 250,000 men, 27,000 of which are in the navy. The defense budget is \$1,300,000,000 or 8.5 percent of the Gross National Product. This is a larger percentage than many other countries.

Yugoslavia has limited shelf area and is on the verge of being a developed country.

**Information Source:** World Almanac Book of Facts, 1986

# NIGERIA

Nigeria is located on the west coast of Africa , along the Gulf of Guinea, just north of the equator. Topography is Nigeria varies greatly. It has hot, rainy swamplands; dry, sandy deserts; grassy plants; tropical forests; high plateaus; and rocky mountains.

**AREA:** 356,669 square miles (the size of Texas and Colorado combined)

**POPULATION:** 86,148,000 (est. 1984) (three times the combined population of Texas and Colorado). In 1980, the enrollment ratio for primary schools was 71 percent.

Three-fourths of the Nigerian people live in rural areas earning their living by farming, fishing, or herding. The per capita income is \$750 U.S. dollars. Most people live in small villages in huts made of grass and dried mud. Over 250 languages are spoken.

Nigeria's economy is based on farming and mining. Nigeria ranks among the world's leading producers of cacao, palm oil and palm kernels, peanuts, and rubber. Other important crops include beans, cassava, corn, millet, rice, and yams. Farmers also raise goats, poultry, sheep, and cattle.

The oil industry is the fastest-growing industry in Nigeria. Most of the oil fields are operated by foreign companies. Many of the oil wells are located on the Nigerian continental shelf in the Gulf of Guinea. Nigeria is a member of OPEC (Organization of Petroleum Exporting Countries). In 1985 over 95 percent of the value of exports was in crude oil. Other minerals are coal, columbite, gold, iron ore, lead, limestone, natural gas, tin, and zinc.

The principal shipping ports include Lagos, Port Harcourt, Warri, and Calabar. In addition to oil it exports cacao beans, palm products, peanuts, rubber, timber, and tin. Important items that must be imported include cement, chemical products, food products, machinery, manufactured goods, and textiles. Nigeria's most important trading partners are Great Britain, the Netherlands, Germany, and the United States.

Over 200,000 persons serve in the Nigerian Army. Nigeria also operates a small navy (4,500 persons), an air force, and a federal police force.

Nigeria has a limited continental shelf and is a developing country.

**Information Source:** World Almanac Book of Facts, 1986  
The New Encyclopaedia Britannica, 1987

## ICELAND

Iceland is a republic located just below the Arctic Circle in the northern Atlantic Ocean. Because of its northern location, it has a relatively cool climate. A large part of the country is covered by an icecap. There is a great deal of volcanic and earthquake activity. Much of its energy comes from hot water that is found at and below the surface.

**AREA:** 102,846 square kilometers or 39,769 square miles (about as big as Kentucky)

**POPULATION:** 239,000 (est. 1984) (about 1/16 the population of Kentucky).  
Education is required through age 16.

Most Icelanders live in coastal towns, making a living by fishing or working in fish processing plants. The per capita income in 1980 was \$9,000 U.S. dollars. Fifteen percent of the Icelanders are farmers, making a living in the fertile lowlands along the southern and western coasts. The major agricultural products are hay, wool, meat, skins, and dairy products.

The most important industry in Iceland is fishing and fish processing. In 1982, its total fish catch was 776,000 metric tons, primarily cod, haddock, and herring. Most of the fish are dried, salted, or frozen, and exported to other countries. Iceland trades mainly with Denmark, Great Britain, Norway, Russia, Spain, Sweden, Switzerland, Germany, and the United States. Fish and whale products are Iceland's greatest exports. A small merchant marine consists of six steam-powered vessels and 987 smaller motor vessels.

Iceland has no army or navy; however, the United States has troops stationed there. Iceland does have a small coast guard, which patrols the fishing area surrounding the island. In 1975, Iceland announced an extension of its fishing rights to 200 miles to protect the fishing stock and its fishing industry.

Iceland is an island country, a fishing country, and developed.

**Information source:** World Almanac Book of Facts, 1986  
The New Encyclopaedia Britannica, 1987

## BOLIVIA

The Republic of Bolivia, located in South America, has been a landlocked country since 1879 when its western neighbor, Chile, seized the Bolivian coastal province, Atacama, in a dispute over nitrate deposits. This isolated country lies between the Amazon jungle and the Andes Mountains. It has high plains, plateaus, mountains, and lowlands. The average temperature varies from 45 degrees to 75 degrees F depending on the region of the country.

Bolivia is often called a "Beggars sitting on a throne of gold." This poor country has large mineral, forest, and water resources, yet lacks the capability for using these resources.

**AREA:** 424,165 square miles (about the size of California and Texas together)

**POPULATION:** 6,195,000 (est. 1985) (one-half the population of Texas). The Literacy Rate was only about 60% in the early 1980s.

Two main social classes exist in Bolivia: "those who have much," and "those who have little." Basically, the majority of Indians and some Mestizos (mixed Indian and White) are poor farmers, miners, and industrial workers. They live in adobe houses and eat corn, cereal, and potatoes as major portions of their diet. The minority Whites and Mestizos dwell in Spanish-style homes in the large cities and primarily operate the businesses. The per capita income in 1982 was \$570 U.S. dollars.

Farming employs over one-half of the Bolivian workers, although only two percent of the land is cultivated. Lack of funds to buy machinery, primitive farming methods, and unwillingness to move to richer lowlands prevent larger crop yield. Beef, cocoa, coffee, corn, cotton, rice, hides, mutton, and sugar are the chief products.

Although poor in many aspects, Bolivia is rich in minerals. Thirteen percent of the world's tin is mined in Bolivia. Other valuable minerals include antimony, bismuth, copper, gold, lead, tungsten, silver, and zinc. Bolivia is also self-sufficient in oil production. Vast forests supply quebracho wood (used in tanning and drying) and rubber. Waterfalls and rapids are possible sources of hydroelectric power.

Since Bolivia is landlocked, trade with other countries is limited. However, surrounding countries allow Bolivia the use of some ports. Arica and Antofagasto, ports in Chile, Mollendo-Matarani in Peru, and La Quiaca on the Amazon, are the most used import-export shipping centers for Bolivia. Of the revenue from exports, 55 percent comes from tin and other exported minerals, vehicles, timber, and wool from the United States and other South American countries. Railroads connect harbors on the Pacific to major cities in Bolivia, making foreign trade easier.

Bolivia employs 24,000 people in the armed forces.

Bolivia is a landlocked country and one of the developing countries.

**Information source:** World Almanac Book of Facts, 1986  
The New Encyclopaedia Britannica, 1987

## BERMUDA

The British dependency, Bermuda, consists of more than 300 coral islands in the North Atlantic Ocean. This favorite resort country is known for its warm, sunny climate, winding roads, palm trees, colorful flowers, and shining beaches. The only source of fresh water in Bermuda is rain water caught off roofs of buildings and stored in tanks outside. Small fish are sometimes put in the tanks to keep them free of mosquito larvae.

**AREA:** 20 square miles or 53 square kilometers (1/8 the size of Columbus, Ohio)

**POPULATION:** 58,000 (est. 1985). The Literacy Rate is almost 100%. Between the ages of 5 and 16, education is mandatory and free.

Only 20 of the 300 Bermudan Islands are inhabited. On these islands, hotels, beaches, and recreational resources attract over 500,000 tourists each year. Tourism represents 44 percent of the Gross National Product. The country has almost no natural resources and therefore must import all energy and minerals.

Farming and fishing employ 1.5 percent of the work force in Bermuda. Bananas, citrus fruits, lilies, potatoes, green vegetables, eggs, and milk are the major farm products.

Bermuda imports three times more goods than it exports in its 200 vessel shipping fleet. Four-fifths of its food must be imported. Britain, the Netherlands, and the United States are Bermuda's biggest customers. In addition, Bermuda re-exports many goods because of ships stopping in major harbors such as Hamilton and St. George for medical, fuel, and other ship supplies.

For defense, Bermuda relies primarily on Britain; however, the Bermuda Regiment defense force employs 350 men. Since Bermuda occupies a very strategic military location, the United States, in 1941, leased 2.3 square miles of land for naval and air force bases.

Bermuda is a developing island country.

**Information source:** World Almanac Book of Facts, 1986  
The New Encyclopaedia Britannica, 1987

## The Challenge of Chief Seattle

Yonder sky that has wept tears of compassion upon our fathers for centuries untold, and which to us looks eternal, may change. Today it is fair. Tomorrow it may be overcast with clouds.

My words are like the stars that never set. What Seattle says, the Great Chief at Washington can rely upon with as much certainty as our paleface brothers can rely upon the return of the seasons.

The son of the White Chief says his father sends us greetings of friendship and good will. This is kind of him, for we know he has little need of our friendship in return because his people are many. They are like the grass that covers the vast prairies, while my people are few, they resemble the scattering trees of a storm-swept plain.

The Great Chief in Washington sent word that he wishes to buy our land. How can you buy or sell the sky, the warmth of the land? The idea is strange to us. If we do not own the freshness of the air and the sparkle of the water, how can you buy them?

Every part of this earth is sacred to my people. Every shining pine needle, every sandy shore, every mist in the dark woods, every clearing, and humming insect is holy in the memory and experience of my people. The sap which courses through the trees carries the memories of the red man.

The white man's dead forget the country of their birth when they go to walk among the stars. Our dead never forget this beautiful earth, for it is the mother of the red man. We are part of the earth and it part of us. The perfumed flowers are our sister; the deer, the horse, the great eagle, these are our brothers. The rocky crests, the juices in the meadows, the body heat of the pony, and man—all belong to the same family.

So, when the Great Chief in Washington sends word that he wishes to buy our land, he asks much of us.

The Great Chief sends word he will reserve us a place so that we can live comfortably to ourselves. He will be our father and we will be his children.

So we will consider your offer to buy our land. But this will not be easy. For this land is sacred to us.

This shining water that moves in the streams and rivers is not just water but the blood of our ancestors. If we sell you land, you must remember that it is sacred, and you must teach your children that it is sacred, and that each ghostly reflection in the clear water of the lakes tells of events and memories in the life of my people. The water's murmur is the voice of my father's father.

The rivers are our brothers, they quench our thirst. The rivers carry our canoes, and feed our children. If we sell you our land, you must remember, and teach your children, that the rivers are our brothers, and yours, and you must henceforth give the rivers the kindness you would give my brother.

The red man has always retreated before the advancing white man, as the mist of the mountain runs before the morning sun. We know that the white man does not understand our ways. One portion of land is the same to him as the next, for he is a stranger who comes in the night and takes from the land whatever he needs. The earth is not his brother, but his enemy, and when he has conquered it, he moves on. He leaves his father's graves behind, and does not care. He kidnaps the earth from his children. He does not care. His father's graces and his

children's birthright are forgotten. He treats his mother, the earth, and his brother, the sky, as things to be bought, plundered, sold like sheep or bright beads. His appetite will devour the earth.

The sight of your cities pains the eyes of the red man. But perhaps it is because the red man is a savage and does not understand.

There is no quiet place in the white man's cities. No place to hear the unfurling of the leaves in spring or the rustle of insect's wings. The clatter only seems to insult the ears. And what is there to life if man cannot hear the lonely cry of the whippoorwill or the arguments of the frogs around a pond at night? The Indian prefers the soft sound of wind darting over the face of a pond, and the smell of the wind itself, cleansed by a midday rain, or scented with the pinon pine.

The air is precious to the red man, for all things share the same breath—the beast, the tree, the man, they all share the same breath. The white man does not seem to notice the air he breathes. Like a man dying for many days, he is numb to the stench. But if we sell you our land, you must remember that the air is precious to us, that the air shares its spirit with all life it supports. The wind that gave our grandfather his first breath also receives his last sigh. And if we sell you our land, you must keep it apart and sacred, as a place where even the white man can go to taste the wind that is sweetened by the meadow's flowers.

So we will consider your offer to buy our land. If we decide to accept, I will make one condition: The White Man must treat the beasts of this land as his brothers. I have seen a thousand rotting buffalo on the prairie, left by the white man who shot them from a passing train. I am a savage and I do not understand how the smoking iron horse can be more important than the buffalo that we kill only to stay alive.

What is man without the beasts? If all the beasts were gone, men would die from a great loneliness of spirit. For whatever happens to the beasts, soon happens to man. All things are connected.

You must teach your children that the ground beneath their feet is the ashes of our grandfathers. So that they will respect the land, tell your children that the earth is rich with the lives of our kin. Teach your children what we have taught our children, that the earth is our mother. Whatever befalls the earth befalls the sons of the earth. If men spit upon the ground, they spit upon themselves.

The earth does not belong to man; man belongs to the earth. All things are connected like the blood which unites one family.

Man did not weave the web of life; he is merely a strand in it. Whatever he does to the web, he does to himself.

Our dead never forget this beautiful world that gave them being. They still love its winding rivers, its great mountains and its sequestered vales, and they ever yearn in tenderest affection over the lonely-hearted living, and often return to visit, guide, and comfort them.

Day and night cannot dwell together. The red man has ever fled the approach of the white man as the changing mist on the mountain side flees before the blazing sun.

However, your proposition seems a just one, and I think that my people will accept it and will retire to the reservation you offer them. There we will dwell apart in peace, for the words of the Great White Chief seem to be the voice of Nature, speaking to my people out of the thick darkness that is fast gathering round them like a dense fog floating inward from a midnight sea.

Our children have seen their fathers humbled in defeat. Our warriors have felt shame, and after defeat they turn their days in idleness and contaminate their bodies with sweet food and strong drink.

It matters little where we pass the remnant of our days. They are not many. The Indian's night promises to be dark. No bright star hovers above his horizon. Sad-voiced wings moan in the distance. Some grim Fate of our race is on the red man's trail, and wherever he goes he will still hear the sure approaching footsteps of his fell destroyer and prepare to stolidly meet his doom, as does the wounded doe that hears the approaching footsteps of the hunter.

A few more hours, a few more winters, and none of the children of the great tribes that once lived on this earth or that roam now in small bands in the woods will be left to mourn the graves of a people once as powerful and hopeful as yours. But why should I mourn the passing of my people? Tribes are made of men, nothing more. Men come and go, like the waves of the sea.

Even the white man, whose God walks and talks with him as friend to friend, cannot be exempt from the common destiny. We may be brothers after all; we shall see. One thing we know, which the White Man may one day discover—our God is the same God. You may think now that you own Him as you wish to own our land; but you cannot. He is the God of Man, and His compassion is equal for the red man and the white. This earth is precious to Him, and to harm the earth is to heap contempt on its Creator. The white too shall pass; perhaps sooner than all other tribes. Continue to contaminate your bed, and you will one night suffocate in your own waste.

But in your perishing you will shine brightly, fired by the strength of the God who brought you to this land and for some

special purpose gave you dominion over this land and over the red man. That destiny is a mystery to us, for we do not understand when buffalo are slaughtered, the wild horses are tamed, the secret corners of the forest heavy with the scent of many men, and the view of the ripe hills blotted by talking wires. Where is the thicket? Gone. Where is the eagle? Gone. And what is it to say goodbye to the swift pony and the hunt? The end of living and the beginning of survival.

When the last red man shall have perished, and the memory of my tribe shall have become a myth among the white man, these shores will swarm with the invisible dead of my tribe, and when your children's children think themselves alone in the field, the store, the shop, or in the silence of the pathless woods, they will not be alone. . . At night when the streets of your cities and villages are silent and you think them deserted, they will throng with the returning hosts that once filled them and still love this beautiful land. The white man will never be alone. When the last red man has vanished from this earth, and his memory is only the shadow of a cloud moving across the prairie, these shores and forests will still hold the spirits of my people. For they love this earth as the newborn loves its mother's heartbeat. So if we sell you our land, love it as we've loved it. Care for it as we've cared for it. Hold in your mind the memory of the land as it is when you take it. And with all your strength, with all your mind, with all your heart, preserve it for your children, and love it. . . as God loves us all.

*Bill Schneider, ed. Montana Outdoors Magazine. The Minnesota Volunteer, November/December, 1976. pp. 1-12.*



---

# The Sea At Last!

---

## Introduction

After four years of adventures, Paddle finally reached the sea. Before he reached the open ocean, though, he was pulled back and forth by the tides in the Gulf of St. Lawrence. How do you think Paddle might have felt as he was pushed closer to the sea and then pulled backwards again? How do you think he felt when he finally arrived in the open ocean?

## Objectives

When the students have completed this activity, they will be able to list the six basic questions a story should answer. They will write a story describing the feelings people might have when they finally reach a personal goal.

## Materials

Paper, pencil or pen, markers or crayons.

## Procedure

1. Discuss with students what they expect to find out when they read any story. Six basic questions should be mentioned:
  - \***WHO** is the story about?
  - \***WHAT** is happening in the story?
  - \***WHY** do these things happen?
  - \***WHEN** is it happening?
  - \***WHERE** does the story take place?
  - \***HOW** is the problem solved? (How does the story end?)
2. Read Chapter 25, *Rivers in the Sea*. Discuss how Paddle might have felt as he was pulled back and forth by the tides and when he finally reached the sea. Have you ever had similar feelings? In what situations? Were those feelings pleasant or unpleasant? Why?
3. Write a story that describes how you or someone else felt about finally reaching an important goal. Or write about Paddle's feelings when he reached the sea. Remember the six questions your story should answer. Try to write the story so that your readers will feel the same way you did.
4. Draw a picture to illustrate your story. Make your picture express the feelings you described in your story. Think about drawing facial expressions and using colors to reflect the mood of your story.
5. Share the stories and drawings with the class. What mood does each drawing convey? Can you answer the six basic questions for each story? Is it as important to work toward a goal as to reach it?

---

# Paddle Makes Headlines

---

## Introduction

Some of the people who helped Paddle during his journey found out what happened to him by reading a newspaper article sent from France. What do you think the article said? How could people in France know something about Paddle's adventures?

## Objectives

When the students have completed this activity, they will be able to list the six basic questions a story should answer. They will write and illustrate a newspaper article with an appropriate headline that summarizes Paddle's journey.

## Materials

Paper, pencil or pen, markers or crayons.

## Procedure

1. Discuss with students what they expect to find out when they read any story.

Six basic questions should be mentioned:

- \* **WHO** is the story about?
  - \* **WHAT** is happening in the story?
  - \* **WHY** do these things happen?
  - \* **WHEN** is it happening?
  - \* **WHERE** does the story take place?
  - \* **HOW** is the problem solved? (How does the story end?)
2. Read Chapter 27, *On a Wharf*. What information was contained in the French newspaper story? A title for a newspaper article is called a **headline**. The headline tells the main idea or subject of the story in just a few words. Can you think of some possible titles for this story?
  3. Write an article about Paddle that might have appeared in the French newspaper. Think about what the people on the wharf found out when they read the article and remember the six questions your story should answer. Be sure to give your article a headline.
  4. Draw a picture to illustrate an event described in your story. You might want to draw how Paddle looked after his long voyage or how Paddle landed on the fishing boat.
  5. Share the articles with the class. Can you answer the six basic questions for each article? What information is the same in all the articles? How do the articles differ?

---

# A Dream Comes True

---

## Introduction

When the Indian boy found out that Paddle had arrived in France, he was very happy. Paddle had survived and had made the journey that the boy was not able to make. The boy's dream for Paddle had become a reality.

## Objectives

When the students have completed this activity, they will be able to list the six basic questions a story should answer. They will write a story describing the feelings people might have when their special dream comes true.

## Materials

Paper, pencil or pen, markers or crayons.

## Procedure

1. Discuss with students what they expect to find out when they read any story. Six basic questions should be mentioned:
  - \* **WHO** is the story about?
  - \* **WHAT** is happening in the story?
  - \* **WHY** do these things happen?
  - \* **WHEN** is it happening?
  - \* **WHERE** does the story take place?
  - \* **HOW** is the problem solved? (How does the story end?)
2. Read Chapter 27, *On a Wharf*. Discuss how the Indian boy felt when he overheard the men discussing the newspaper story about Paddle. What words in the chapter let you know how he felt. Why was he so happy? Have you ever had similar feelings? In what situations?
3. Write a story which describes how you or someone else felt about having a special dream come true. Or write about the Indian boy's feelings after he knew Paddle had survived his journey. Remember the six questions your story should answer. Try to write the story so that your readers will feel the same way you did.
4. Draw a picture to illustrate your story. Make your picture express the feelings you described in your story. Think about drawing facial expressions and using colors to reflect the mood of your story.
5. Share the stories and drawings with the class. What kinds of dreams were described in the stories? Can you answer the six basic questions for each story?

---

## Some Additional Resources for Teaching About the Great Lakes

---

- Ashworth, William. *The Late, Great Lakes*. New York: Alfred A. Knopf, 1986.  
Well-written overview of economic and environmental development in the region. Tends to emphasize negative aspects, however.
- Barry, James P. *The Fate of the Lakes*. New York, Bonanza Books, 1972.  
Color-illustrated review of environmental problems as they were in the 1970s. Use with updated references for best effect. (Things are different now!)
- Botts, Lee and Bruce Krushelnicki. *The Great Lakes, An Environmental Atlas and Resource Book*. Environment Canada and USEPA, 1987.  
An excellent paperbound booklet of maps showing updated information about a wide range of characteristics of the Great Lakes Basin. Includes a wall map. Full color. Available free from your nearest Environment Canada or USEPA office.
- Burns, Noel M. *Erie: The Lake That Survived*. Totowa, NJ: Rowan and Allanheld, 1985.  
Well-written scientific approach to changes that have occurred in the Great Lakes, with Lake Erie as the most visible example.
- Fortner, Rosanne W. and Victor J. Mayer, eds. *The Great Lake Erie*. Columbus: The Ohio State University, 1987.  
Sixteen papers (155 pp) by experts on the science and social studies topics addressed in *Paddle-to-the-Sea*. Available from the School of Natural Resources at Ohio State, \$15 plus 15% for postage and handling.
- Freshwater Society. *The Great Lakes Directory of Natural Resources Agencies and Organizations*. Chicago: Center for the Great Lakes, 1984/85. 200 pp.  
Comprehensive listing and description of information sources. Good for identification of local resource groups. Can be purchased from the Center for the Great Lakes, 435 N. Michigan Avenue, Chicago, IL 60611. 1985 price \$20.
- Great Lakes Science Advisory Board. *Directory of Great Lakes Education Material*. Windsor, Ontario: International Joint Commission, 1988.  
Description of print and audiovisual materials for teaching about the Great Lakes, as well as sources of additional materials. Revised regularly. Does not contain evaluations or prices. Available free from IJC.
- Rousmaniere, John, ed. *The Enduring Great Lakes*. New York: W.W. Norton, 1979.  
Adapted from an issue of NATURAL HISTORY magazine from the American Museum of Natural History. Well-written background information on the basic scientific research involving the lakes and their life forms.

## Oceanic Education Activities for Great Lakes Schools (OEAGLS)

Results of studies of student knowledge about the oceans and Great Lakes environments indicate a need for greater awareness of those environments and a greater understanding of the impact they have upon the lives of people. OEAGLS (pronounced "eagles") are designed to take a concept or idea from the existing school curriculum and develop it into an oceanic and Great Lakes context, using teaching approaches and materials appropriate for children in grades five through nine.

OEAGLS materials are designed to be easily integrated into existing curricula. Investigations are characterized by subject matter compatibility with existing curriculum topics; short activities lasting from one to three classes; minimal preparation time; minimal equipment needs; standard page size for easy duplication; student workbook plus teacher guide; suggested extension activities for further information or creative expression; teachability demonstrated by use in middle school classrooms, and content accuracy assured by critical reviewers. Each title consists of a student workbook and a teacher guide and costs \$3.00 for the publication, postage, and handling. If ordering EP-026, add an additional \$4.00 to cover the cost of the computer disk.

THE EFFECT OF THE GREAT LAKES ON TEMPERATURE (EP-001)

THE EFFECT OF THE GREAT LAKES ON CLIMATE (EP-002)

ANCIENT SHORES OF LAKE ERIE (EP-003)

HOW TO PROTECT A RIVER (EP-004)

CHANGING LAKE LEVELS (EP-005)

EROSION ALONG THE GREAT LAKES (EP-006)

COASTAL PROCESSES AND EROSION (EP-007)

POLLUTION IN LAKE ERIE: AN INTRODUCTION (EP-008)

YELLOW PERCH IN LAKE ERIE (EP-009)

EVIDENCE OF ANCIENT SEAS IN OHIO (EP-010)

TO HARVEST A WALLEYE (EP-011)

OIL SPILL! (EP-012)

SHIPPING ON THE GREAT LAKES (EP-013)

GEOGRAPHY OF THE GREAT LAKES (EP-014)

OHIO CANALS (EP-015)

THE ESTUARY: A SPECIAL PLACE (EP-016)

THE GREAT LAKES TRIANGLE (EP-017)

KNOWING THE ROPES (EP-018)

GETTING TO KNOW YOUR LOCAL FISH (EP-019)

SHIPPING: THE WORLD CONNECTION (EP-020)

WE HAVE MET THE ENEMY (EP-021)

IT'S EVERYONE'S SEA: OR IS IT? (EP-022)

PCBs IN FISH: A PROBLEM? (EP-023)

A GREAT LAKES VACATION (EP-024)

STORM SURGES (EP-025)

RIVER TREK with computer program (EP-026)

WAVES (EP-027)

LAKE LAYERS: STRATIFICATION (EP-028)

NUTRIENTS IN THE GREAT LAKES (EP-029)

EATING LIKE A BIRD (EP-030)

**National Sea Grant Depository**  
Pell Library Building - GSO  
University of Rhode Island  
Narragansett, RI 02882-1197USA

### OEAGLets

In the primary grade range we have three activities. All use Lake Erie information applied to all primary subject areas. Each title costs \$5.00 for the publication, postage, and handling.

LAKE ERIE—TAKE A BOW (EP-031)

BUILD A FISH TO SCALE (EP-032)

A DAY IN LIFE OF A FISH (EP-033)

### COMPUTER PROGRAMS

All programs run on Apple II computer series.

EP-24/Disk This program is an optional purchase to accompany OEAGLS *A Great Lakes Vacation*. \$4.00

EP-074/Disk To accompany OEAGLS EP-011, 019, 021, and 023. \$5.00

### ADDITIONAL EDUCATIONAL MATERIALS

SUPPLEMENTAL CURRICULUM ACTIVITIES TO ACCOMPANY HOLLING C. HOLLING'S

*PADDLE -TO-THE-SEA* (EP-076) \$10.00

ACTIVITIES FROM MIDDLE SEA (EP-071) \$2.50

WATERWORKS (EP-072) \$2.50

THE OHIO SEA GRANT EDUCATION PROGRAM: DEVELOPMENT, IMPLEMENTATION, EVALUATION (EP-075) \$8.00

MARINE EDUCATION BIBLIOGRAPHY \$2.00

### OTHER PUBLICATIONS AVAILABLE

*TWINE LINE* Sea Grant eight-page bimonthly newsletter. \$4.50 for six issues.

PUBLICATION BROCHURE Free.

EDUCATION BROCHURE Free.

TECHNICAL PUBLICATIONS BROCHURE Free.

SEA GRANT PROGRAM BROCHURE Free.

GREAT LAKES PURSUIT *S.E. Flaumer and R.W. Forner*. A game played like *Trivial Pursuit* ® but the questions challenge players to learn about the Great Lakes. \$24.00 (see education publication brochure for price to educators).

TOO MUCH MUSSEL 1991. This 5 1/2 minute video (VHS format) provides an overview of the zebra mussel impact to Lake Erie. \$15.00.



**Ohio Sea Grant College Program**  
The Ohio State University  
1314 Kinnear Road  
Columbus, OH 43212-1194  
Tel. 614/292-8949  
Fax 614/292-4364

(Send all publication requests to this address.)

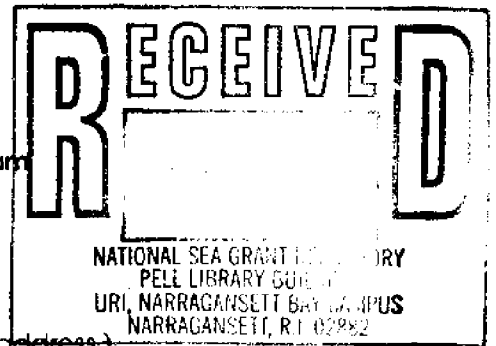

For information about the education program, contact the  
Ohio Sea Grant Education Coordinator, *Dr. Rosanne W. Fortner*, at The Ohio State University  
(59 Ramseyer Hall, 29 W. Woodruff Avenue, Columbus, OH 43210-1077, 614/292-1078).

*Dr. Jeffrey M. Reutter*, Ohio Sea Grant Director