

CIRCULATING COPY
Sea Grant Depository

FORCES DUE TO WAVES
ON
SUBMERGED STRUCTURES

Prepared by

G. EDWARD SHANK and JOHN B. HERBICH
Coastal and Ocean Engineering Division
Texas Engineering Experiment Station

May 1970

TAMU-SG-70-212

COE Report No. 123

TEXAS A&M UNIVERSITY  SEA GRANT PROGRAM

CIRCULATING COPY
Sea Grant Depository

FORCES DUE TO WAVES
ON
SUBMERGED STRUCTURES

by

G. Edward Shank and John B. Herbich
Coastal and Ocean Engineering Division
Texas A&M University

Partially Supported by the National Science Foundation
Sea Grant Program
Institutional Grant GH-59 to
Texas A&M University

Sea Grant Publication No. TAMU-SG-70-212
Coastal and Ocean Engineering Division
Report No. 123 - C.O.E.

May 1970

ABSTRACT

Forces due to gravity waves on several models of half-cylindrical and rectangular shape were determined experimentally in a two dimensional wave tank. The parameters of water depth, wave length and wave height were varied and their effect on forces determined. The horizontal and vertical forces on the model were measured by instrumented load cells. They were recorded on electronic recorders. The results were analyzed with the aid of a digital computer. Forces computed using existing theories were compared to measured forces and the results used to determine inertial coefficient. The results of the data were plotted in dimensionless form to provide a correlation between ratios of wave length/water depth, wave height/wave length, and dimensionless force. The dimensionless force curves can be used to estimate forces due to waves on a prototype.

PREFACE

Research described in this report was conducted as part of the research program in Coastal and Ocean Engineering at Texas A&M University.

The report was primarily written by the senior author in partial fulfillment of the Master of Science requirement under the supervision of the junior author who was his major advisor.

Mr. Ralph L. Cooper was of great assistance in writing the computer program for reduction of data and computation of forces. Due to the massive amount of data involved, the project would have been impossible to complete without the program.

The review of this study by Professor Robert O. Reid and Professor Bill C. Moore in the preparation of the report is very much appreciated.

The research set forth in this report was supported by the National Science Foundation Sea Grant Program Institutional Grant GH-59 to Texas A&M University. It was also supported by the Naval Facilities Engineering Command.

TABLE OF CONTENTS

Section	Page
INTRODUCTION	1
LITERATURE SURVEY.	3
THEORETICAL CONSIDERATIONS	14
EXPERIMENTAL EQUIPMENT AND PROCEDURE	23
PRESENTATION AND DISCUSSION OF RESULTS	39
CONCLUSIONS AND RECOMMENDATIONS FOR FURTHER RESEARCH	46
BIBLIOGRAPHY	48
APPENDICES	
Appendix I - NOTATION.	51
Appendix II - DIMENSIONLESS FORCE SUMMARY CURVES.	54
Appendix III - INERTIAL COEFFICIENT CURVES	67
Appendix IV - COMPARISON OF MEASURED AND COMPUTED HORIZONTAL FORCES.	82
Appendix V - SAMPLE COMPUTATION OF HORIZONTAL FORCE.	92
Appendix VI - COMPUTER PROGRAM FOR WAVE PARAMETERS AND INERTIAL WAVE FORCES	95
Appendix VII - COMPUTER PROGRAM FOR OBJECTS OF IRREGULAR CROSS SECTION.	104
Appendix VIII - COMPUTER PROGRAM FOR FORCE COMPUTATION BY MORISON EQUATION	113

LIST OF FIGURES

Figure		Page
1	WAVE DEFINITION SKETCH FOR AIRY WAVE THEORY	16
2	MODELS STUDIED.	24
3	CLOSE-UP OF FOUR INCH LONG RECTANGULAR MODEL.	24
4	WAVE GENERATOR.	25
5	EXPERIMENTAL FACILITY	25
6	SCHEMATIC DIAGRAM OF TEST FACILITY.	31
7	CLOSE-UP OF EXPERIMENTAL SET UP	32
8	HALF-CYLINDER MODEL IN PLACE.	34
9	SCHEMATIC DIAGRAM OF MODEL AND LOAD CELL.	35
10	RECORDER OUTPUT FOR VERTICAL FORCES AND WAVE CREST INDICATOR.	37
11	RECORDER OUTPUT FOR HORIZONTAL FORCES, VERTICAL FORCES AND WAVE PROFILE.	38
12	SAMPLE DIMENSIONLESS HORIZONTAL FORCE PLOT FOR FLAT PLATE.	42

INTRODUCTION

In recent years, offshore oil exploration and production have moved to remote areas of the world far from natural or artificial harbors. Sometimes the harbors in the remote areas do not have adequate handling capacities to accommodate even small tankers. It appears that savings in both capital investment and operating costs may be realized if the oil could be stored in submerged tanks in the oil producing areas. This conclusion is reached by Chamberlin (2) in his consideration of underwater tank designs. Also in cases of small, undeveloped offshore fields it may not be economical to pump oil using a pipeline to shore and to develop shore facilities.

One of such underwater storage tanks was recently installed in the Middle East by the Chicago Bridge and Iron Company. This tank has a 500,000 barrel capacity, is about 260 feet in diameter and about 65 feet high. It was installed in water 156-feet deep. Since such a tank involves a large investment of money and since no adequate theoretical solutions are available to date, extensive model wave tank investigations were conducted prior to design and construction of the tank by the Chicago Bridge and Iron Company.

The Institute of Ocean Development (8) in Tokyo conducted field

The citations on the following pages follow the style of the Journal of the Hydraulics Division, Proceedings of the American Society of Civil Engineers.

studies in Chiba Port adjacent to Tokyo with a model one-tenth the size of the prototype tank. The upper half of the model was hemispherical in shape and utilized flexible material. The lower half of the model was ellipsoidal in shape and was made from steel. The model had a capacity of about 10,000 gallons.

The United States Commission on Marine Science, Engineering and Resources (3, 4) and the Oceanographer of the Navy (14) have predicted that underwater facilities will be built at an increasing rate in the near future. These will be built either in connection with oil and gas production, or in connection with mineral recovery from the ocean bottom, or as underwater habitats. Submerged military support bases for submersibles are predicted. These support bases will eliminate sea state as a cause for the prevention or termination of operations to support submersibles. Habitats can support scientific explorations and the exploitation of the natural resources of the ocean floor. A great need exists to be able to predict forces caused by waves on submerged structures. Until better theoretical force predictions are available, design criteria will have to rely upon model tests.

On the basis of model tests, this thesis provides design information about wave forces on a selected number of shapes of underwater structures.

LITERATURE SURVEY

Forces on a body oscillating in a viscous fluid or on a fixed body in an oscillating viscous fluid are due to two causes. These are inertia and drag. The drag term is a function of velocity, the inertial term a function of acceleration. This observation was first made by G. G. Stokes (9) in 1851.

Forces on piles due to gravity waves were first studied by Morison, O'Brien, Johnson and Schaaf (1) in 1950. They set forth the so-called, and well known "Morison Equation" which relates forces to wave parameters. The force was found to consist of two components. These were a drag force proportional to the square of the velocity which may be represented by a drag coefficient having substantially the same value as for steady flow and a virtual mass force proportional to the horizontal component of the acceleration force exerted on the mass of displaced water. The Morison Equation is:

$$F = F_D + F_M = 1/2 C_D \rho A |u| u + C_M \rho V \frac{\partial u}{\partial t} \dots \dots \dots (1)$$

where:¹

F = Total force

F_D = Drag force

¹The literature survey will use the symbols as they appear in the cited literature, and will be redefined for each author. Symbols for other sections of the thesis will be consistent and will be defined only the first time they appear. A list of symbols is given in Appendix I.

F_M = Inertial force

C_D = Drag coefficient

C_M = Inertial coefficient

A = Cross sectional area of object in direction perpendicular to the wave travel

V = Volume of object

ρ = Mass density

u = Horizontal velocity of water particle

$\frac{\partial u}{\partial t}$ = Horizontal acceleration of water particle

To verify the theory experimentally, a pile was attached by its base to the bottom of a wave channel and restrained by a load cell at the top. The laboratory results showed close agreement between computed and measured force with the exception of some experimental scatter. Further work on waves on piles was published by Morison (11) in 1951 and Morison, Johnson and O'Brien (12) in 1954 utilizing the same basic relationship.

In 1952 O'Brien and Morison (13) applied the Morison Equation to a submerged spherical object. The components of force were due to both drag and inertia. Forces on the sphere were evaluated when it was suspended from a rod above the bottom and when it was placed on the bottom by use of a tee made of razor blades. The tee was made by attaching two razor blades to the tank bottom. The blades were perpendicular to the direction of wave travel and parallel to each other. The suspended sphere was used to measure horizontal force. The sphere on the tee was used to measure

vertical force. In the latter case, the period was held constant and the wave height raised in small increments until the sphere tipped off the tee. The uplift force was equal to the weight of the sphere when movement occurred. Drag force and inertial force were computed by utilizing the measured force in the cases where the crest, trough and nodes of the wave were over the sphere.

In 1953 Reid and Bretschneider (15) utilized the Morison Equation for the computation of wave forces on piles and derived formulas for computation of wave forces on large submerged objects. The forces on large objects were found to be almost entirely inertial. This permitted force due to drag to be neglected in force computations. Due to the fact that inertial force is a function of particle acceleration, once drag is neglected the maximum horizontal force occurs when the wave node is over the model center. The inertial force was computed directly from the horizontal distribution of pressure. The equations developed by Reid are simple, straight-forward and accurate for large objects where drag forces are negligible and inertial forces predominant. For forces on a large submerged object utilizing small amplitude (Airy) wave theory:

$$F_H = C_M L^2 L_3 \frac{K \gamma H}{2} \left[\cos \theta_1 - \cos \left(\theta_1 + \frac{2\pi L_1}{L} \right) \right] \dots \dots \dots (2)$$

where:

F_H = Total horizontal force

C_M = Inertial coefficient

L_1 = Length of structure (in direction of wave travel)

L_2 = Width of structure

L_3 = Height of structure

K = Pressure factor = $\frac{1}{\cosh \frac{2\pi d}{L}}$

d = Water depth

L = Wave length

γ = Specific weight

H = Wave height

θ_1 = Phase angle (position) of end of model facing waves
measured from crest in direction of wave travel

The maximum value of F for this wave will occur when the center of the object is at the position $\theta = \frac{\pi}{2}$ radians. Thus:

$$F_{\text{Max}} = C_M L_2 L_3 K \gamma H \sin \left(\frac{\pi L_1}{L} \right) \dots \dots \dots (3)$$

A re-analysis of all existing data on wave forces on piles was made by Crooke (5) in 1955. His paper reconciled differences in previous studies by applying a consistent approach which resulted in reasonable results. He applied the Iverson approach to wave forces. The analysis was made utilizing only one coefficient in the wave force equation. This coefficient was dependent both upon velocity and acceleration.

$$C = \phi \left(\frac{AL}{V^2}, \frac{VL}{u}, \frac{V^2}{gL} \right) \dots \dots \dots (4)$$

where:

$$\frac{AL}{V^2} = \text{Iversen's modulus}$$

$$\frac{VL\rho}{\mu} = \text{Reynolds number}$$

$$\frac{V^2}{gL} = \text{Froude number}$$

A = Particle acceleration

V = Particle velocity

L = Characteristic length

ρ = Density

μ = Viscosity

g = Gravity

Crooke's approach worked well for deep and shallow water waves as long as the appropriate wave theory was used.

In 1958 Keulegan and Carpenter (9) investigated the inertial and drag coefficients of cylinders and plates when exposed to gravity waves. They found that a remainder function ΔR could be introduced to provide a truer representation of force when considering the coefficients C_M and C_D as being constant through the wave cycle. ΔR was required because the point values of C_M and C_D differed from their average values. They also found that average values of C_D and C_M could be correlated with point values in the Morison Equation by introducing a parameter $\frac{U_m T}{D}$.

where:

U_m = Maximum horizontal particle velocity

T = Wave period

D = Diameter of cylinder or width of plate

The Morison Equation thus modified becomes:

$$\frac{F}{\rho U_m^2 D} = \left(\frac{\pi}{4} C_m\right) \left(\frac{D\sigma}{U_m} \sin\theta\right) - \frac{C_D}{2} |\cos\theta| \cos\theta \dots \dots (5)$$

where:

ρ = Density

$\sigma = 2\pi/T$

θ = Phase angle

When ΔR is introduced into this equation as a remainder it becomes:

$$\frac{F}{\rho U_m^2 D} = \left(\frac{\pi}{4} C_m\right) \left(\frac{D\sigma}{U_m} \sin\theta\right) - \frac{C_D}{2} |\cos\theta| \cos\theta + \Delta R \dots \dots (6)$$

ΔR is obtained by subtracting the computed values for

$$\left(\frac{\pi}{4} C_m\right) \left(\frac{D\sigma}{U_m} \sin\theta\right) - \frac{C_D}{2} |\cos\theta| \cos\theta$$

from observed values for

$$\frac{F}{\rho U_m^2 D}$$

It was found that inertial coefficient and drag coefficient varied with the diameter of the cylinder. For a given cylinder it varied with the values of maximum current U_m . A strong correlation between the period parameter $\frac{U_m T}{D}$ and inertial and drag coef-

ficients was found to exist.

It was found that for the plates the higher values of the drag coefficient are obtained at the smaller values of

$$\frac{U_m T}{D}$$

and the higher values of inertial coefficient are associated with larger values of

$$\frac{U_m T}{D}$$

Brater, McNown and Stair (1) investigated experimentally the effect of gravity waves on models of submerged barge-like structures in 1958. They evaluated a flat plate, a right parallelepiped and two parallelepipeds with a somewhat modified shape. The models were suspended from rods instrumented with load cells. The Morison Equation was utilized for analysis.

$$F = 1/2 C_D A \rho |u|u + C_m \rho V \frac{\partial u}{\partial t} \dots \dots \dots (7)$$

where:

C_D = Drag coefficient

A = Cross sectional area of model

ρ = Density

u = Horizontal particle velocity

C_m = Inertial coefficient

V = Volume of model

$\frac{\partial u}{\partial t}$ = Horizontal acceleration of particle

The maximum force on the model structures occurred between $\frac{X}{L} = 0$ and $\frac{X}{L} = 1/4$

where:

L = Wave length

X = Distance from wave crest to location of maximum force measured in direction of wave travel

Drag forces were found to be negligible on the barge. Analysis of the results were made utilizing the inertial portion only. The analysis of inertial force used pressure to evaluate horizontal force.

$$(P_1 - P_2) A_x = \rho V \frac{\partial u}{\partial t} \dots \dots \dots (8)$$

where:

P_1 = Pressure on front of model

P_2 = Pressure on rear of model

This expression is substituted in the inertial portion of the Morison Equation to yield

$$F_i = C_m (P_1 - P_2) A_x \dots \dots \dots (9)$$

where:

F_i = Portion of force due to inertia

The equation of motion in the vertical direction is

$$\frac{\partial p}{\partial z} = -w + \rho \frac{\partial v}{\partial t} \dots \dots \dots (10)$$

where:

$\frac{\partial P}{\partial z}$ = Increment of pressure

w = Specific weight of water

When Eq. 10 is substituted into the Airy expressions for particle acceleration and integrated, the result is

$$P = w(-z + y) + \rho \frac{\pi LH}{T^2} \frac{\cosh 2\pi(d+z)/L - \cosh 2\pi(d+y)/L}{\sinh 2\pi d/L} \cos \theta \quad (11)$$

where:

y = Elevation of surface above still water

z = Distance from water surface to model

H = Wave height

T = Wave period

d = Depth of water

For the case of maximum force which occurs when the model is centered at the quarter point of the wave, the above equation becomes:

$$P_1 - P_2 = wH \cos \frac{2\pi x_1}{L} \left[K - 2 \sinh^2 \left(\frac{\pi H \cos 2\pi x_1 / L}{2L} \right) \right] \dots \quad (12)$$

where:

x_1 = Horizontal distance from wave crest to leading edge of barge

$$K = \frac{\cosh 2\pi(d+z)/L}{\cosh 2\pi d/L}$$

When measured values are substituted in Eq. 12 the value of

$(P_1 - P_2)$ can be computed. Eq. 9 can be rewritten as

$$C_m = \frac{F_i}{(P_1 - P_2)Ax} \dots \dots \dots (13)$$

from which C_m can be computed.

Both drag force and inertial force were found to be significant in the results from the flat plate. Values of C_D and C_M which yielded the best correspondence with measured forces and phase angles were utilized in the Morison Equation. The values for computed wave parameters were derived utilizing Airy theory. For any given wave, the force is a function of the phase angle only. The Morison Equation was modified as follows to derive the phase angle for maximum force where drag and inertial forces were both significant,

$$F = C_D' \cos^2 \theta + C_m' \sin \theta \dots \dots \dots (14)$$

where:

F = Total force

θ = Phase angle

$$C_D' = C_D A \rho \frac{\pi H^2}{2T^2} \left[\frac{\cosh 2\pi (d+z)/L}{\sinh 2\pi d/L} \right]^2 \dots \dots \dots (15)$$

$$C_m' = C_m \rho V \frac{2\pi^2 H}{T^2} \left[\frac{\cosh 2\pi (d+z)/L}{\sinh 2\pi d/L} \right] \dots \dots \dots (16)$$

The phase angle for maximum force is obtained by setting $dF/d\theta = 0$, with the result

$$\sin \theta_{\max} = \frac{C_m'}{2C_D'} \dots \dots \dots (17)$$

They found that inertial coefficient for the barge was 1.5.

Forces obtained from tests of a barge with rounded edges and a barge with a slot in the center were not substantially different from those obtained from tests on a normal barge with square edges. This was due to the fact that inertial force is a function of volume. Measured inertial forces on the barge agrees well with theory. The drag coefficient for the plate was 3.5 and virtual mass (the product of volume and C_m) was 1.75 times that of a circumscribing cylinder.

A recent paper by Evans (6) published results of study of forces on piles of full-size prototype offshore platforms. He utilized the Morison Equation to compare computed predictions with measured results. The measured data included waves of large size (up to 106 ft.) due to hurricanes. His data was taken during two extended periods. They were 1954 to 1958 and 1960 to 1963. The study proved the accuracy of the Morison Equation. The average values of measured and theoretical forces were within 15 percent of each other. The value obtained for C_D was 0.5. The value for C_m was 1.5. This agrees well with previous work done by others and summarized by Wilson and Reid (17). The drag coefficients were found to decrease for increasing wave height. The inertial coefficient did not change greatly with moderate changes in wave size. However, it doubled in value from a 23 ft. wave to a 106 ft. wave.

THEORETICAL CONSIDERATIONS

Progressive linear wave (Airy) theory is used for this study. A brief presentation is made of the portions appropriate to this work. Detailed development is made by Eagleson and Dean (7) and Wiegel (16).

Airy theory makes the following assumptions:

That the bottom is smooth and impermeable

That the fluid is incompressible, irrotational and inviscid

That the depth is constant (measured from water level)

That surface tension is neglected

That coriolis force is neglected

That atmospheric pressure is constant

That the height of the surface is small in comparison with
wave length

That all non-linear terms may be neglected

The wave surface is described by the following relationship:

$$\eta = \frac{H}{2} \cos 2\pi \left(\frac{x}{L} - \frac{t}{T} \right) \dots \dots \dots (18)$$

where:

η = Distance of the free surface from mean water level

x = Distance from the wave crest measured in the direction
of wave travel

L = Wave length

H = Wave height

t = Time

T = Wave period

Some of the various wave measurements and parameters which will be used in this section and the results and conclusions section are shown in Fig. 1.

The velocity potential for the small amplitude wave is given by the expression

$$\phi = \frac{ga}{\sigma} \frac{\cosh k(z+d)}{\cosh kd} \cos(kx - \alpha t) \dots \dots \dots (19)$$

where:

ϕ = Velocity potential

g = Gravity

a = Wave amplitude = $H/2$

σ = $2\pi/T$

z = Distance from still water level

d = Water depth

k = $2\pi/L$

The celerity of the wave is given by the expression:

$$C = \frac{gT}{2\pi} \tanh \frac{2\pi d}{L} = \left[\frac{gL}{2\pi} \tanh \frac{2\pi d}{L} \right]^{1/2} \dots \dots \dots (20)$$

where:

C = Celerity

The expression for wave length is:

$$L = \frac{gT^2}{2\pi} \tanh \frac{2\pi d}{L} \dots \dots \dots (21)$$

In deep water the depth becomes large relative to wave length and the hyperbolic tangent function ($\tanh \frac{2\pi d}{L}$) approaches unity.

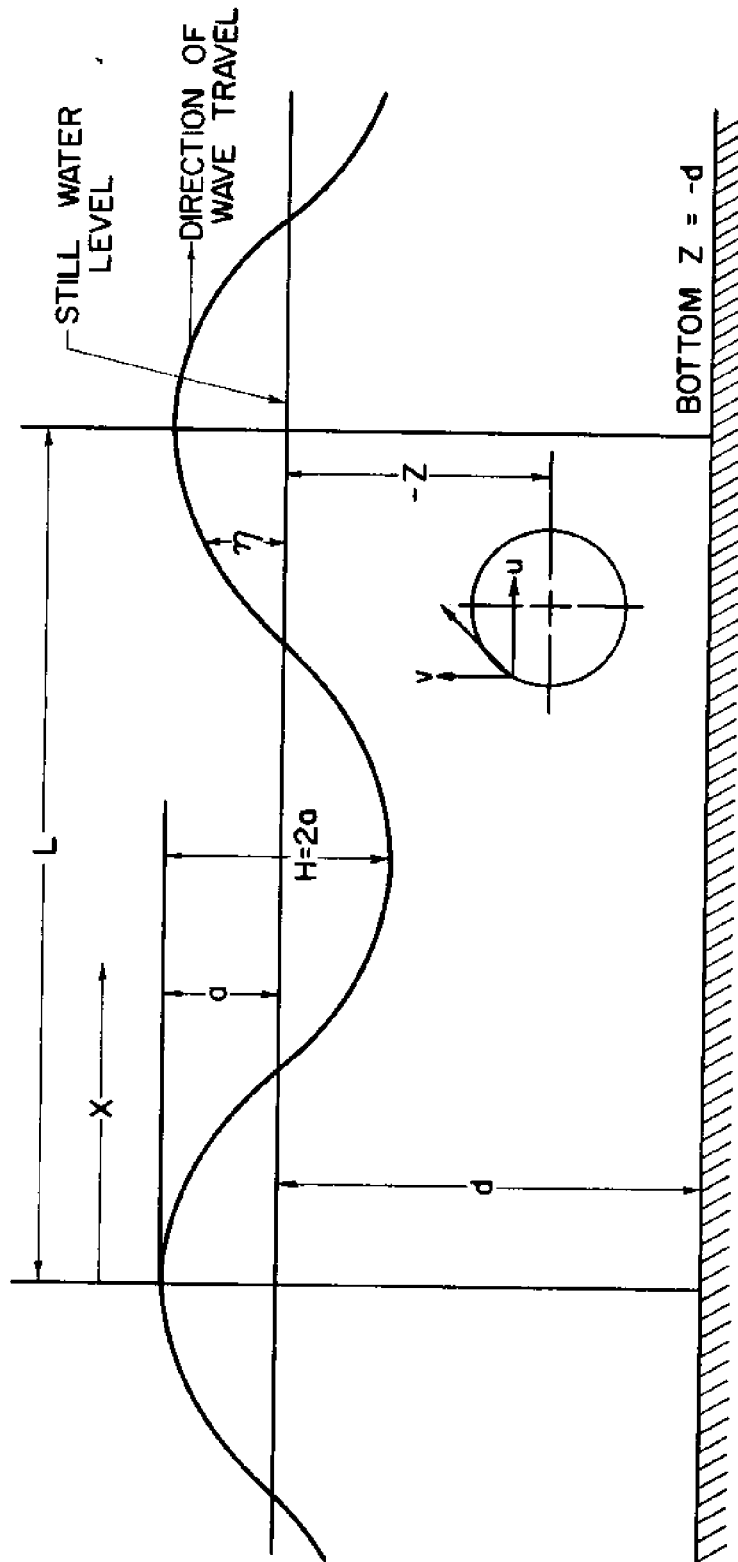

FIG. 1 — WAVE DEFINITION SKETCH FOR AIRY WAVE THEORY

Wave celerity becomes

$$C_o = \left[\frac{gL}{2\pi} \right]^{1/2} \dots \dots \dots (22)$$

where:

C_o = Deep water celerity and wave length becomes

$$L_o = \frac{gT^2}{2\pi} = 5.12 T^2 \dots \dots \dots (23)$$

where:

L_o = Deep water wave length

The wave period is an independent variable. It also remains relatively constant irregardless of changes in wave height, water depth, and wave length. If corresponding expressions for general waves and deep water waves are solved using a constant depth, the following expression results

$$\frac{d}{L} \tanh \frac{2\pi d}{L} = \frac{d}{L_o} \dots \dots \dots (24)$$

This enables direct solution for the wave length from the deep water wave length which is easily calculated from Eq. 23.

The horizontal component of water particle velocity is given by the expression.

$$u = \frac{\partial \phi}{\partial x} = \frac{gak}{\sigma} \frac{\cosh k(z+d)}{\cosh kd} \cos (kx - \sigma t) \dots \dots \dots (25)$$

where:

u = Horizontal velocity of water particle

The horizontal component of water particle acceleration is

given by the expression:

$$\dot{u} = \frac{\partial u}{\partial t} = g a k \frac{\cosh k(z+d)}{\cosh kd} \sin (kx - \sigma t) \dots \dots \dots (26)$$

where:

\dot{u} = Horizontal acceleration of water particle

The Morison Equation relates force to particle motion.

$$F_h = 1/2 \rho C_D A |u| u + \rho C_m V \dot{u} \dots \dots \dots (27)$$

where:

ρ = Density

F_h = Horizontal force

For a given vertical increment of the model, this expression becomes

$$dF_h = dF_D + dF_I \dots \dots \dots (28)$$

where:

F_D = Force due to drag

F_I = Force due to inertia

$$dF_I = C_m \rho W_m L_m \dot{u} dz \dots \dots \dots (29)$$

where:

W_m = Width of model

L_m = Length of model

H_m = Weight of model

The total inertial force can be obtained from substitution of Eq. 26, in Eq. 29 and integration of the resultant expression.

$$F_I = C_m \rho W_m L_m \int_{-d}^{-d + H_m} - \frac{2\pi^2 h}{T^2} \frac{\cosh k(d+z)}{\sinh kd} \sin \sigma t \, dz \dots (30)$$

$$= (C_m \rho W_m L_m) \left(\frac{-2\pi^2 H \sin \sigma t}{T^2 \sinh kd} \right) \int_{-d}^{-d + H_m} \cosh k(d+z) \, dz$$

$$= (C_m \rho W_m L_m) \left(\frac{-2\pi^2 H \sin \sigma t}{T^2 \sinh kd} \right) \left(\frac{\sinh k(d+z)}{k} \right) \Bigg|_{-d}^{-d + H_m}$$

$$= (C_m \rho W_m L_m) \left(\frac{-2\pi^2 H \sin \sigma t}{T^2 \sinh kd} \right) \left(\frac{\sinh k(d-d+H_m) - \sinh k(d-d)}{k} \right)$$

$$= (C_m \rho W_m L_m) \left(\frac{-2\pi^2 H \sin \sigma t}{T^2 \sinh kd} \right) \left(\frac{\sinh dk H_m}{k} \right) \dots \dots \dots (31)$$

The force due to drag on a vertical increment of model is

$$dF_D = 1/2 C_D \rho W_m |u|u \, dz \dots \dots \dots (32)$$

The total drag force can be obtained by substitution of Eq. 25 in Eq. 32 and integration of the resultant expression.

$$F_D = 1/2 C_D \rho W_m \int_{-d}^{-d + H_m} |u|u \, dz \dots \dots \dots (33)$$

$$= 1/2 C_D \rho W_m \int_{-d}^{-d + H_m} \left(\frac{\pi H}{T}\right)^2 \left(\frac{\cosh k(d+z)}{\sinh kd} \cos \sigma t\right)^2 dz$$

$$= 1/2 C_D \rho W_m \left(\frac{\pi H}{T}\right)^2 \left(\frac{|\cos \sigma t| \cos \sigma t}{(\sinh kd)^2}\right) \int_{-d}^{-d + H_m} \cosh^2 k(d+z) dz$$

$$= 1/2 C_D \rho W_m \left(\frac{\pi H}{T}\right)^2 \left(\frac{|\cos \sigma t| \cos \sigma t}{(\sinh kd)^2}\right) \left[\frac{\sinh 2k(d+z)}{4} + \frac{k(d+z)}{2}\right] \Bigg|_{-d}^{-d + H_m}$$

$$= 1/2 C_D \rho W_m \left(\frac{\pi H}{T}\right)^2 \left(\frac{|\cos \sigma t| \cos \sigma t}{(\sinh kd)^2}\right) \left(\frac{\sinh 2k(d-d+H_m)}{4} + \frac{k(d-d+H_m)}{2} - \frac{\sinh 2k(d-d)}{4} - \frac{k(d-d)}{2}\right)$$

$$= 1/2 C_D \rho W_m \left(\frac{\pi H}{T}\right)^2 \left(\frac{|\cos \sigma t| \cos \sigma t}{(\sinh kd)^2}\right) \left(\frac{\sinh 2k H_m}{4} + \frac{k H_m}{2}\right) \dots (34)$$

If a submerged object has a large volume, the inertial forces predominate, and the drag forces can be ignored. If it has a length in the direction of wave travel which is large compared to the wave length, an analysis of force can be computed directly from the horizontal distribution of pressure beneath the wave.

The difference between the actual gauge pressure at the bottom and the calculated hydrostatic pressure based on the still water depth is defined as pressure anomaly.

$$\Delta P = P - \gamma d \dots \dots \dots (35)$$

where:

ΔP = Pressure anomaly

P = Gauge pressure

γ = Specific weight of water

A pressure factor which is a function of H/d is defined as follows

$$K = \frac{(\Delta p)_c - (\Delta p)_t}{\gamma H} \dots \dots \dots (36)$$

where:

K = Pressure factor

$(\Delta p)_c$ = Pressure anomaly under the wave crest

$(\Delta p)_t$ = Pressure anomaly under the wave trough

$$K = \frac{1}{\cosh \left(\frac{2\pi d}{L} \right)} \dots \dots \dots (37)$$

For Airy wave theory the variation of $\Delta p/\gamma H$ with phase angle is a function $\left(\frac{K}{2}\right) \cos \theta$ where θ is the phase angle, and is equal to ωt or kx .

The general equation for horizontal force acting on a large rectangular submerged object is

$$F_h = C_m H_m W_m [\Delta P_1 - \Delta P_2] \dots \dots \dots (38)$$

where:

ΔP_1 = Pressure anomaly at leading edge of object

ΔP_2 = Pressure anomaly at trailing edge of object

In the special case of the Airy theory wave

$$F_h = C_m H_m W_m \frac{K \gamma H}{2} [\cos \theta_1 - \cos(\theta_1 + 2\pi \frac{L_m}{L})] \dots \dots \dots (39)$$

where:

$$\theta_1 = \frac{2\pi x_1}{L}$$

x_1 = Horizontal distance from the leading edge in direction of wave travel relative to a crest

The maximum value of the horizontal force $(F_H)_{\max}$ occurs when the center of the tank is at the position

$$\theta = \frac{\pi}{2}$$

radians. Therefore,

$$(F_H)_{\max} = C_m H_m W_m K \gamma H \sin \left(\frac{\pi L_m}{L} \right) \dots \dots \dots (40)$$

EXPERIMENTAL EQUIPMENT AND PROCEDURE

Models

With the exception of the flat plate the models were all constructed from plexiglass. The flat plate was fabricated from aluminum. All models used (with the exception of the aluminum plate) are shown in Fig. 2 and Fig. 3. The models consisted of

- (a) plate 7-23/32 in. wide, 4-1/2 in. high and 5/8 in. thick.
- (b) rectangular tank 7-23/32 in. wide, 4-1/2 in. high and 2 in. long.
- (c) rectangular tank 7-23/32 in. wide, 4-1/2 in. high and 4 in. long.
- (d) rectangular tank 7-23/32 in. wide, 4-1/2 in. high and 8 in. long.
- (e) a half-cylinder tank having radius equal to 4-15/32 in. and length equal to 7-11/16 in.

Equipment and Procedure

The models were placed in a three feet deep, two feet wide and one hundred and twenty feet long wave channel. Waves were generated with an oscillating pendulum-type generator capable of producing a wide range of wave lengths and heights. The generator is powered with a variable speed motor. The wave period of the waves was varied by changing the speed of the motor. The wave generator is shown in Fig. 4.

The wave height was changed by varying the adjustment on the

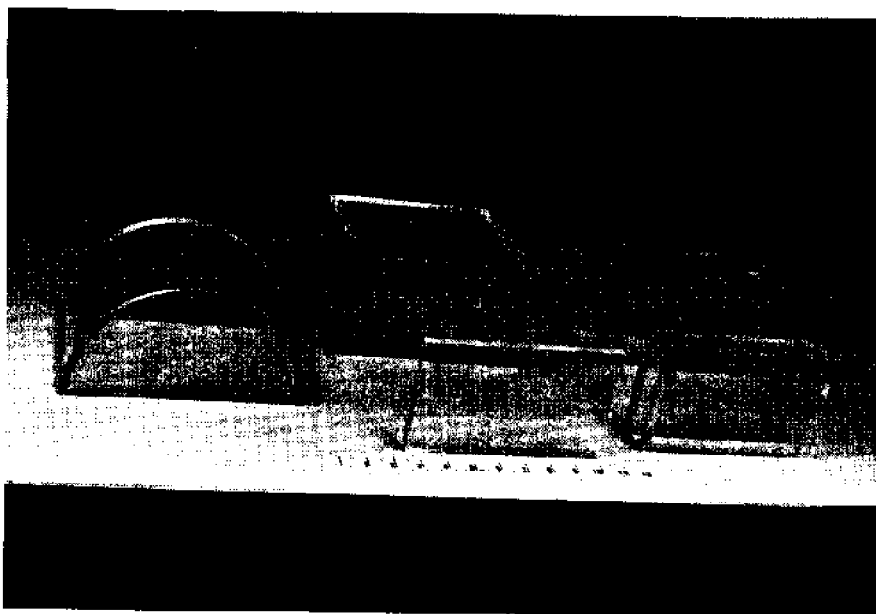

FIG. 2.-MODELS STUDIED

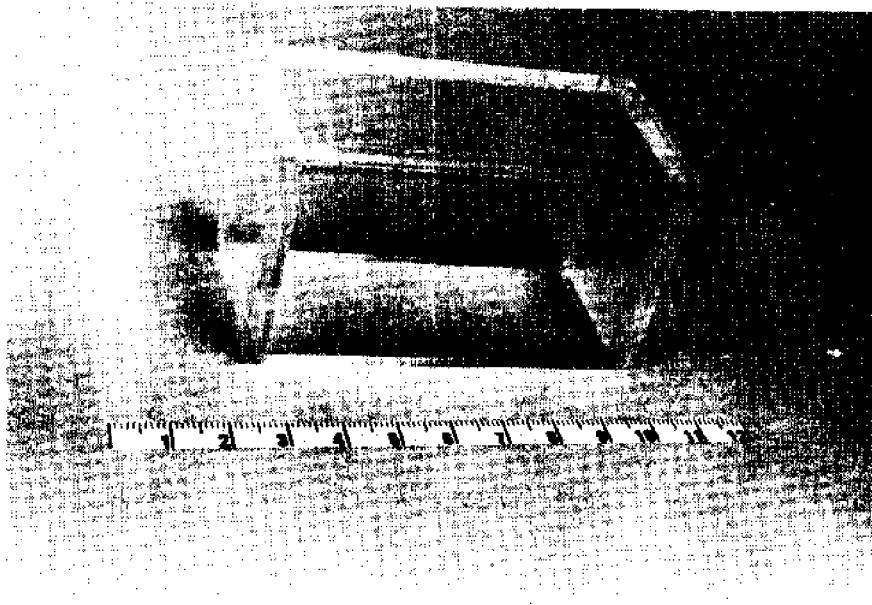

FIG. 3.-CLOSE-UP OF FOUR INCH LONG RECTANGULAR MODEL

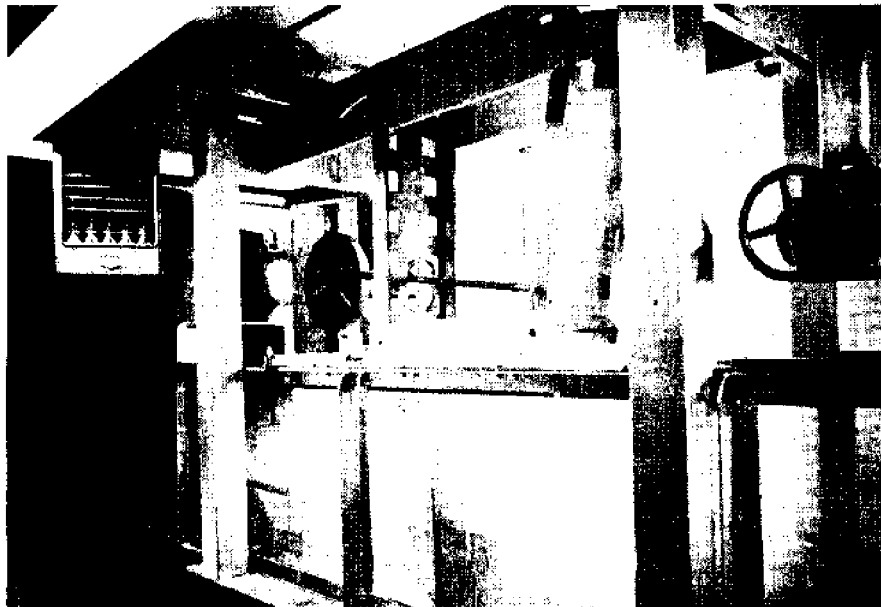

FIG. 4.-WAVE GENERATOR

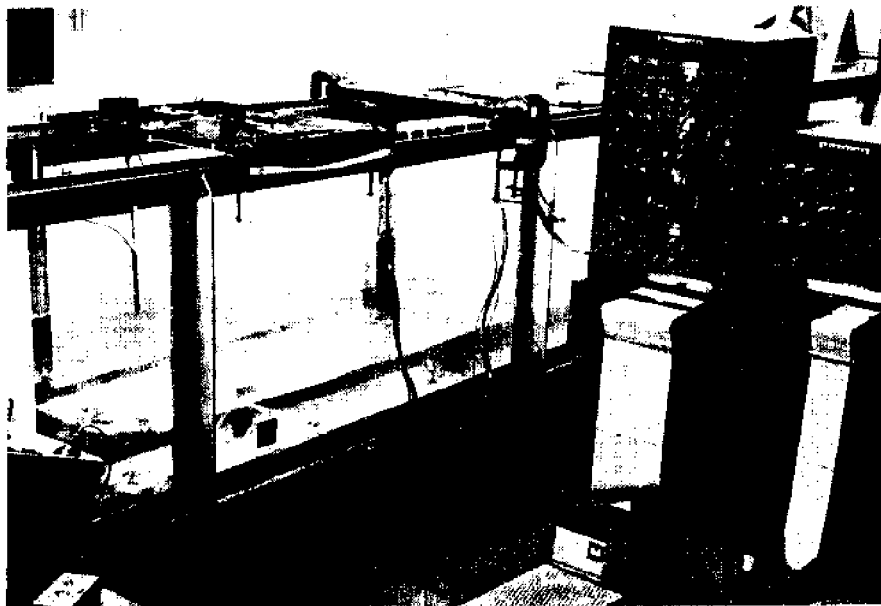

FIG. 5.-EXPERIMENTAL FACILITY

excentricity of the paddle arm on the flywheel which resulted in a change in the stroke of the pendulum. The pendulum was adjusted to provide the proper shape for each wave. A stroke which had equal amplitude from top to bottom was used for the most shallow water waves. A stroke with a large amplitude at the top and a small amplitude at the bottom was used for deep water waves. An efficient absorber is installed at the other extremity of the tank to prevent reflected waves from interfering with generated incident waves. The absorber has a permeable face with an impermeable backing. The channel has 3/8 inch glass side panels throughout its length to allow for visual observation of experiments.

The experiments were conducted at water depths of 24 inches, 18 inches and 13 inches. Wave lengths were varied to produce several L/d ratios between 1.5 and 6.0. This covers deep water waves and the deep half of intermediate waves (where intermediate waves are defined as having a L/d ratio between 2 and 20). The pendulum was timed by stopwatch through 20 to 50 cycles and the period determined to the closest 1/100 second.

Approximately 100 different combinations of water depth, wave period (and consequently wave length) and wave height were used for each model. The wave heights were increased until the waves broke. The schedule of test waves used are shown in Table 1. For each combination of water depth and wave period the schedule increases wave height to a value which will yield a steepness equal to the theoretical maximum of 1.43. A total of 599 different experimental

TABLE 1. - TEST WAVE SCHEDULE

Test Wave Number	Depth in feet	Period in seconds	Wave Height in feet	d/L	L/d	H/L
1	2.000	1.68	0.10	0.178	5.61	0.009
2	2.000	1.68	0.20	0.178	5.61	0.018
3	2.000	1.68	0.30	0.178	5.61	0.027
4	2.000	1.68	0.40	0.178	5.61	0.036
5	2.000	1.68	0.50	0.178	5.61	0.044
6	2.000	1.68	0.60	0.178	5.61	0.053
7	2.000	1.68	0.70	0.178	5.61	0.062
8	2.000	1.55	0.10	0.203	4.93	0.010
9	2.000	1.55	0.20	0.203	4.93	0.020
10	2.000	1.55	0.30	0.203	4.93	0.030
11	2.000	1.55	0.40	0.203	4.93	0.041
12	2.000	1.55	0.50	0.203	4.93	0.051
13	2.000	1.55	0.60	0.203	4.93	0.061
14	2.000	1.55	0.70	0.203	4.93	0.071
15	2.000	1.29	0.10	0.265	3.77	0.013
16	2.000	1.29	0.20	0.265	3.77	0.027
17	2.000	1.29	0.30	0.265	3.77	0.040
18	2.000	1.29	0.40	0.265	3.77	0.053
19	2.000	1.29	0.50	0.265	3.77	0.066
20	2.000	1.29	0.60	0.265	3.77	0.080
21	2.000	1.29	0.70	0.265	3.77	0.092
22	2.000	1.09	0.10	0.342	2.92	0.017
23	2.000	1.09	0.20	0.342	2.92	0.034
24	2.000	1.09	0.30	0.342	2.92	0.051
25	2.000	1.09	0.40	0.342	2.92	0.068
26	2.000	1.09	0.50	0.342	2.92	0.086
27	2.000	1.09	0.60	0.342	2.92	0.103
28	2.000	0.89	0.10	0.505	1.98	0.025
29	2.000	0.89	0.20	0.505	1.98	0.051
30	2.000	0.89	0.30	0.505	1.98	0.076
31	2.000	0.89	0.40	0.505	1.98	0.101
32	2.000	0.89	0.50	0.505	1.98	0.126

TABLE 1. - TEST WAVE SCHEDULE
(Continued)

Test Wave Number	Depth in feet	Period in seconds	Wave Height in feet	d/L	L/d	H/L
33	2.000	0.78	0.10	0.646	1.55	0.032
34	2.000	0.78	0.20	0.646	1.55	0.065
35	2.000	0.78	0.30	0.646	1.55	0.097
36	2.000	0.78	0.40	0.646	1.55	0.129
37	2.000	0.78	0.50	0.646	1.55	0.161
38	1.500	0.71	0.10	0.579	1.73	0.039
39	1.500	0.71	0.20	0.579	1.73	0.077
40	1.500	0.71	0.30	0.579	1.73	0.116
41	1.500	0.71	0.40	0.579	1.73	0.154
42	1.500	0.79	0.10	0.467	2.14	0.031
43	1.500	0.79	0.20	0.467	2.14	0.062
44	1.500	0.79	0.30	0.467	2.14	0.093
45	1.500	0.79	0.40	0.467	2.14	0.125
46	1.500	0.79	0.50	0.467	2.14	0.156
47	1.500	0.92	0.10	0.353	2.84	0.023
48	1.500	0.92	0.20	0.353	2.84	0.047
49	1.500	0.92	0.30	0.353	2.84	0.070
50	1.500	0.92	0.40	0.353	2.84	0.094
51	1.500	0.92	0.50	0.353	2.84	0.117
52	1.500	0.92	0.60	0.353	2.84	0.140
53	1.500	1.09	0.10	0.265	3.78	0.018
54	1.500	1.09	0.20	0.265	3.78	0.035
55	1.500	1.09	0.30	0.265	3.78	0.053
56	1.500	1.09	0.40	0.265	3.78	0.071
57	1.500	1.09	0.50	0.265	3.78	0.088
58	1.500	1.09	0.60	0.265	3.78	0.106
59	1.500	1.31	0.10	0.200	5.01	0.013
60	1.500	1.31	0.20	0.200	5.01	0.027
61	1.500	1.31	0.30	0.200	5.01	0.040
62	1.500	1.31	0.40	0.200	5.01	0.053
63	1.500	1.31	0.50	0.200	5.01	0.067
64	1.500	1.31	0.60	0.200	5.01	0.080
65	1.500	1.31	0.70	0.200	5.01	0.093

TABLE 1. - TEST WAVE SCHEDULE
(Continued)

Test Wave Number	Depth in feet	Period in seconds	Wave Height in feet	d/L	L/d	H/L
66	1.500	1.47	0.10	0.171	5.85	0.011
67	1.500	1.47	0.20	0.171	5.85	0.023
68	1.500	1.47	0.30	0.171	5.85	0.034
69	1.500	1.47	0.40	0.171	5.85	0.046
70	1.500	1.47	0.50	0.171	5.85	0.060
71	1.500	1.47	0.60	0.171	5.85	0.068
72	1.500	1.47	0.70	0.171	5.85	0.080
73	1.083	1.26	0.10	0.169	5.93	0.016
74	1.083	1.26	0.20	0.169	5.93	0.031
75	1.083	1.26	0.30	0.169	5.93	0.047
76	1.083	1.26	0.40	0.169	5.93	0.062
77	1.083	1.26	0.50	0.169	5.93	0.078
78	1.083	1.26	0.60	0.169	5.93	0.093
79	1.083	1.04	0.10	0.220	4.54	0.020
80	1.083	1.04	0.20	0.220	4.54	0.041
81	1.083	1.04	0.30	0.220	4.54	0.061
82	1.083	1.04	0.40	0.220	4.54	0.081
83	1.083	1.04	0.50	0.220	4.54	0.102
84	1.083	1.04	0.60	0.220	4.54	0.122
85	1.083	0.89	0.10	0.283	3.53	0.026
86	1.083	0.89	0.20	0.283	3.53	0.052
87	1.083	0.89	0.30	0.283	3.53	0.078
88	1.083	0.89	0.40	0.283	3.53	0.105
89	1.083	0.89	0.50	0.283	3.53	0.131
90	1.083	0.89	0.60	0.283	3.53	0.157
91	1.083	0.75	0.10	0.382	2.62	0.035
92	1.083	0.75	0.20	0.382	2.62	0.070
93	1.083	0.75	0.30	0.382	2.62	0.106
94	1.083	0.75	0.40	0.382	2.62	0.141
95	1.083	0.71	0.10	0.421	2.37	0.039
96	1.083	0.71	0.20	0.421	2.37	0.078
97	1.083	0.71	0.30	0.421	2.37	0.117
98	1.083	0.71	0.40	0.421	2.37	0.156

runs were made. The resulting massive amount of data provided almost total coverage within the range of wave parameters tested.

An over-all view of the experimental facility is shown in Fig. 5. A schematic diagram of the experimental facility is shown in Fig. 6. To accomplish the force measurements the model was supported by four vertical wires with the upper ends of the wires supported from cantilevered load cells. The wire was 0.015 inch diameter stainless steel cable. It was composed of 7 strands and provided a supple, inelastic support for the model. It was fastened to the model by brass and stainless steel swivel snap hooks at the lower end and connected to the load cell by a threaded eye bolt at the upper end. The cable was fastened to the snap hook and threaded eye by use of a crimped stainless steel sleeve. The threaded eye had 1 1/2 inches of threaded shaft to facilitate vertical adjustment of the models. The models were placed with their base 1/4 inch above the tank bottom. A close-up view of the experimental set up is shown in Fig. 7.

Vertical forces caused the load cells to move in a vertical direction. The load was measured by strain gauges and recorded on electronic recorders.

Since wave forces produce loads both up and down on the model, it was necessary to have it weighted with metal inside the model so that the vertical load lines were pretensioned. This pretension was of high enough value so that the lines never went slack. By hanging the structure from four load lines it was also

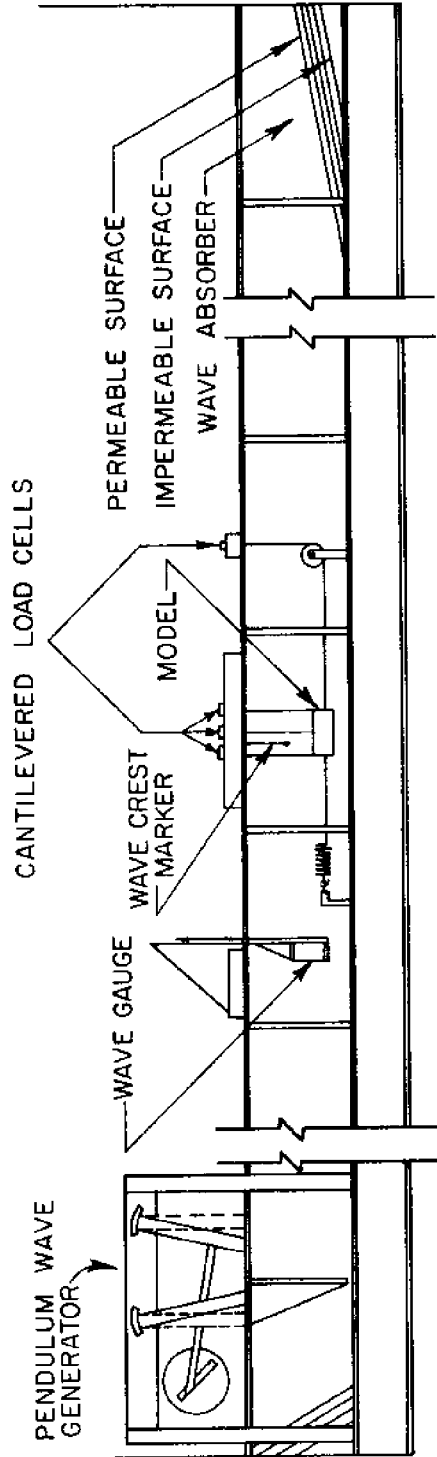

FIG. 6 - SCHEMATIC DIAGRAM OF TEST FACILITY

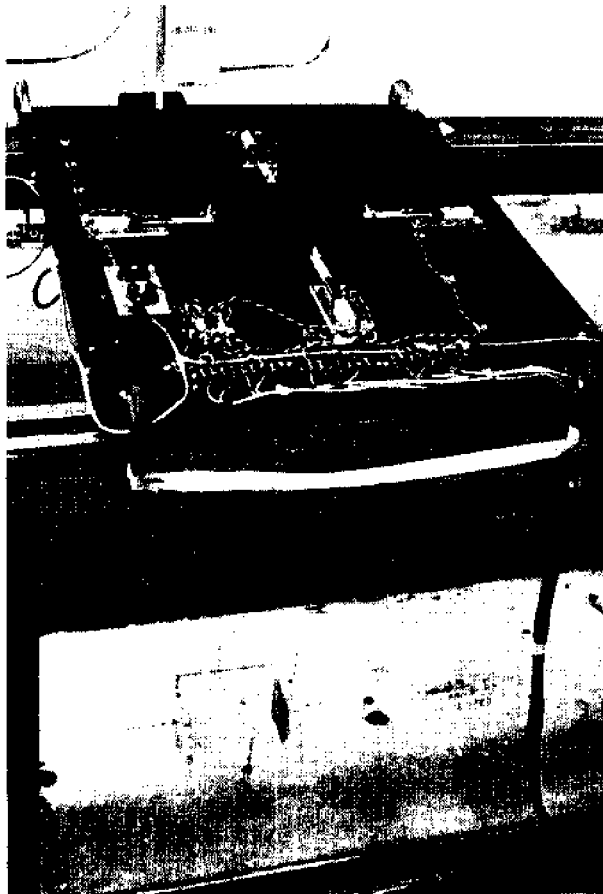

FIG. 7.-CLOSE-UP OF EXPERIMENTAL SET-UP

possible to measure moments on the model. A model suspended from the vertical load cells is shown in Fig. 8.

The horizontal forces were measured as follows: A wire and spring were used to attach the forward end of the model to the wave tank bottom. The downstream end of the model was attached by a wire which was diverted ninety degrees over a pulley to a load cell. The spring provided a constant tension, the variation of which was measured by the load cell and indicated the wave induced horizontal force on the model. The measured load was recorded on an electronic recorder.

Both the stud and the pulley were placed at a horizontal distance of three feet from the model to minimize disturbance in the model area. A large diameter (5 inches) ball bearing pulley was used to minimize the effects of friction. A schematic diagram of the model and load cells is shown in Fig. 9. Known weights were used to calibrate the force measurement apparatus. A capacitance type wave gauge was used to measure wave profiles. The wave gauge was calibrated by immersing the gauge wire into the water by incremented known distances with the water still in the channel. The wave height and wave profiles were recorded on an electronic recorder.

A probe was positioned adjacent to the model so that the passing of each wave crest past the model would be marked on the recorder. This made possible the measurement of the phase angle (or time difference) between the crest and the maximum wave forces.



FIG. 8.-HALF-CYLINDER MODEL IN PLACE

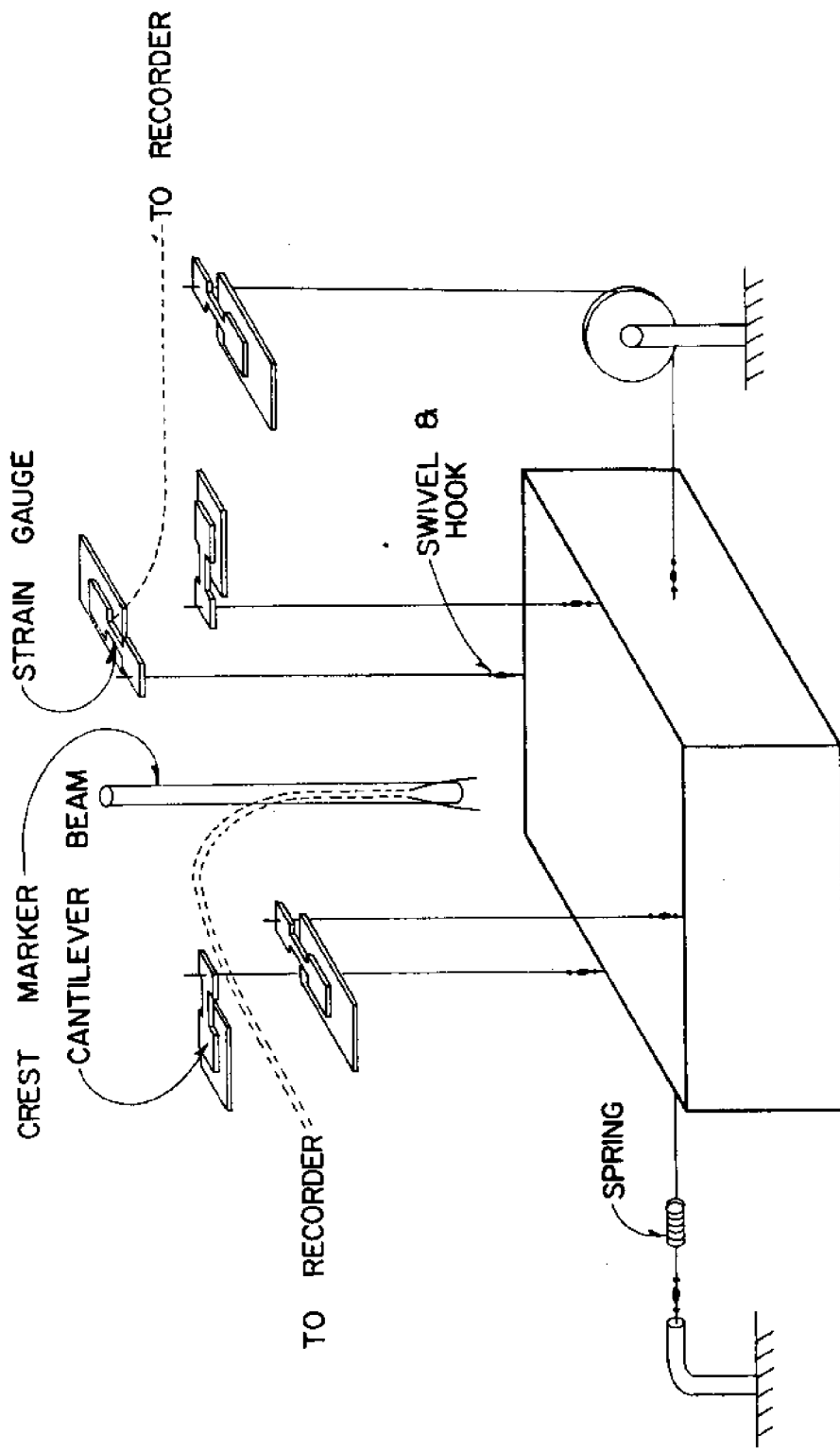

FIG. 9 - SCHEMATIC DIAGRAM OF MODEL AND LOAD CELL

A synchronized marker was used to place a common time mark simultaneously on each recorder data paper. This enabled the data outputs from the three recorders to be correlated in time. The data was recorded on hot needle-type direct-recording equipment. The wave height and wave profiles were recorded on a Hewlett-Packard dual-channel carrier pre-amplifier recorder (model 321). The wave forces were recorded on Sanborn two-and four-channel recorders (model 150). Recorder outputs are shown in Fig. 10 and Fig. 11.

Recording Permapaper

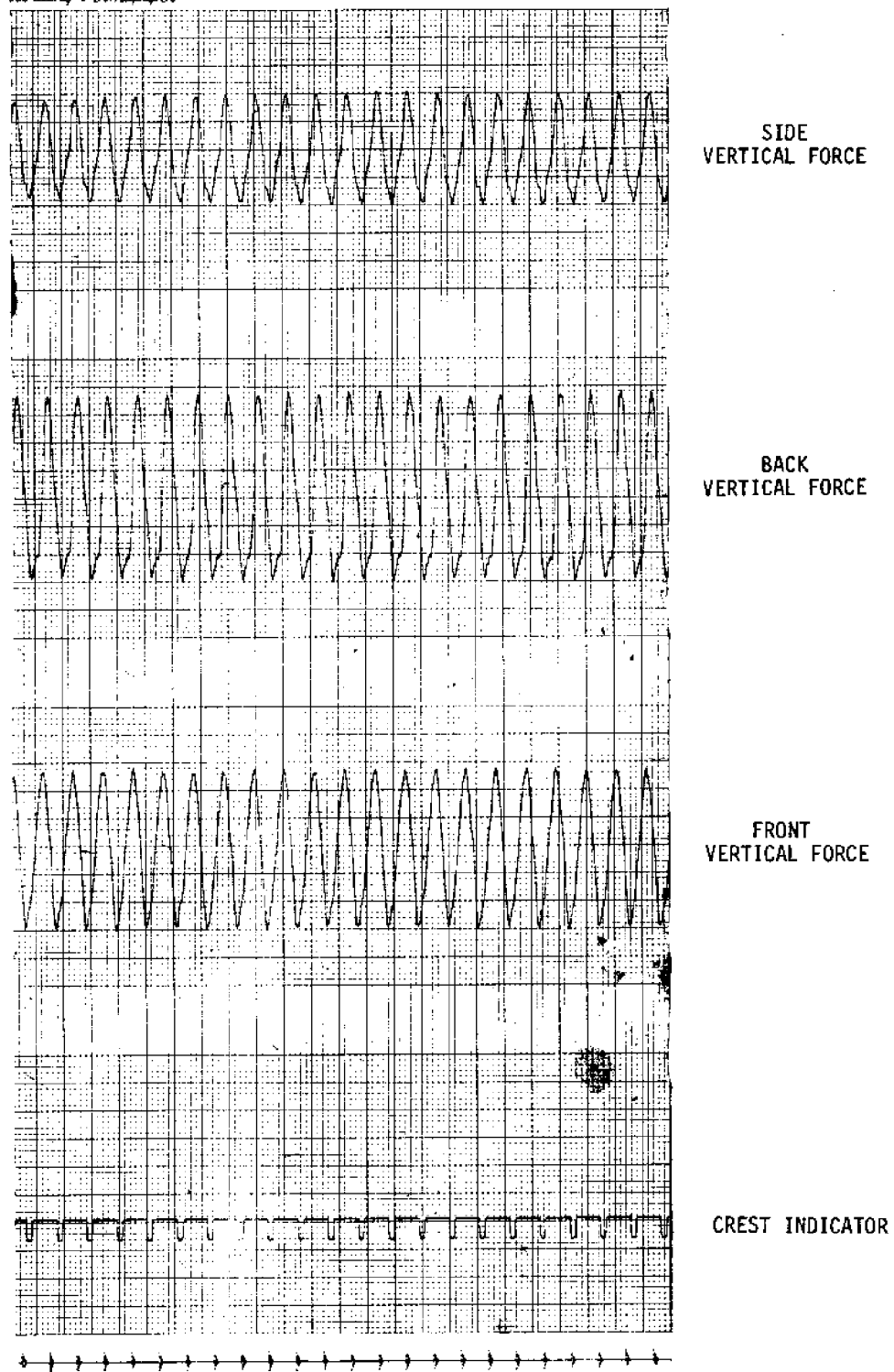

FIG. 10.-RECORDER OUTPUT FOR VERTICAL FORCES AND WAVE CREST INDICATOR

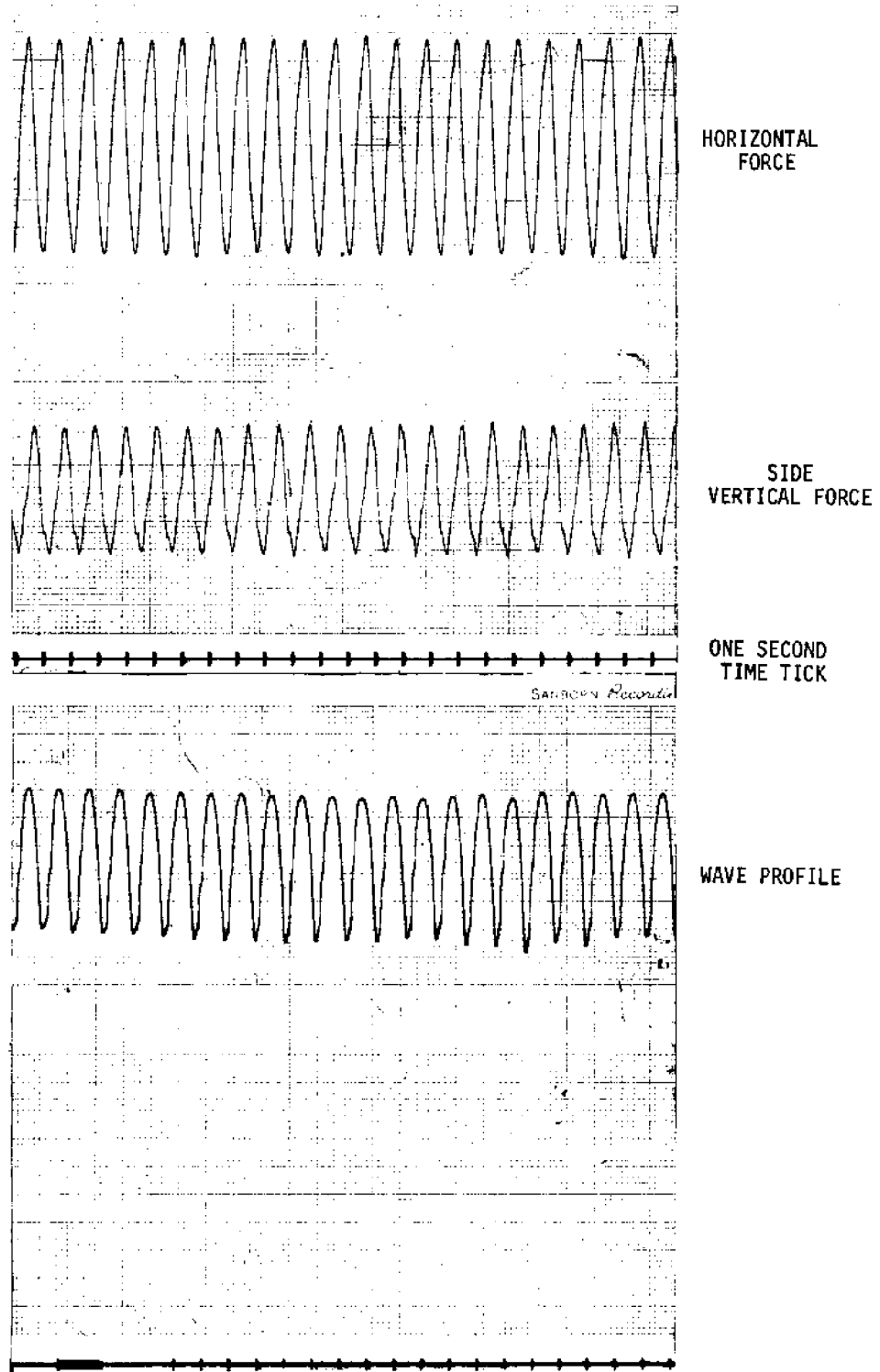

FIG. 11.-RECORDER OUTPUT FOR HORIZONTAL FORCES, VERTICAL FORCES AND WAVE PROFILE

PRESENTATION AND DISCUSSION OF RESULTS

The primary objective of the research was to determine experimentally the forces due to gravity waves on several submerged structures of rectangular and half cylindrical shape. The relation between measured vertical and horizontal force and various wave parameters was investigated. Forces determined by experiment were compared to those calculated using existing theories for wave forces on submerged objects. Wave reflections from the model were assumed to be small. Therefore, they were not measured and were neglected in the theoretical analysis.

The raw data was in the form of recorder output shown in Fig. 10 and Fig. 11. The period was determined by measurement of the length in decimeters between a wave crest, and the crest of the 20th wave following it. The paper feed was 5 millimeters per second, so twenty waves allowed reading the measured decimeter length as a wave period in seconds. The period thus determined was compared to the period measured by timing the pendulum.

An average of at least 10 waves was taken for the maximum wave height, maximum horizontal force and each of the four vertical maximum vertical forces (one for each supporting wire). The upward force for each wire was measured separately from its downward force. The force in the direction of wave travel was measured separately from the force in the opposite direction of wave travel.

Once the raw data was reduced to numerical values, it was

reduced by use of an IBM model 360/65 digital computer. The inputs to the computer program were run serial number, wave period, water depth, wave height, measured horizontal force in the direction of wave travel, measured horizontal force in the direction opposite from wave travel, measured vertical force down, vertical force up and phase angle between the wave crest and maximum forces. The program averaged the wave period for each group of waves where the water depth was constant and the period nominally constant. From the average period, the water depth and the wave height, the program computed the depth to length (d/L) ratio, the length to depth (L/d) ratio and the steepness (H/L).

The units of the measured forces were grams. These measured forces were converted to dimensionless form by the program. The dimensionless force was calculated as follows:

$$F_{DIM} = \frac{F_{max}}{\gamma \frac{A^3}{d} \frac{H}{2}} \dots \dots \dots (41)$$

where:

F_{DIM} = Dimensionless force

F_{max} = Maximum force measured

A = Significant linear dimension equal to height of the model squared divided by length of model in direction of wave propagation for all models except flat plate

$A = H_m$ = Height of model for flat plate

The computer program which calculates wave parameters and dimensionless forces and a sample of computer output are presented in Appendix VI.

A dimensionless plot was made of dimensionless force versus steepness for each group of waves with constant depth and period (constant L/d ratio). A sample plot of dimensionless force versus steepness is shown in Fig. 12. The horizontal force with the direction of the wave was usually slightly higher than the horizontal force exerted against the direction of the wave. As the forces in the two directions closely approximated each other in magnitude, a single curve was used to represent both sets of points.

A cross-plot was made from the dimensionless force versus steepness plot. This cross-plot summarized data by plotting dimensionless force versus L/d ratio for wave steepnesses of 0.02 to 0.07. These summary plots are made for vertical and horizontal forces for all models with the exception of the flat plate. Only horizontal forces were plotted for the flat plate. These curves are presented in Appendix II. Since data are in dimensionless form, they can be extrapolated to any size rectangular object or to any size of a geometrically similar half-cylinder object for any wave height, wave length and water depth. An illustration of the use of the curves is given in Appendix V.

An attempt was made to evaluate both inertial and drag coefficient by use of the Morison Equation. This evaluation was made by computer solution of Eq. 28, Eq. 31 and Eq. 34. The

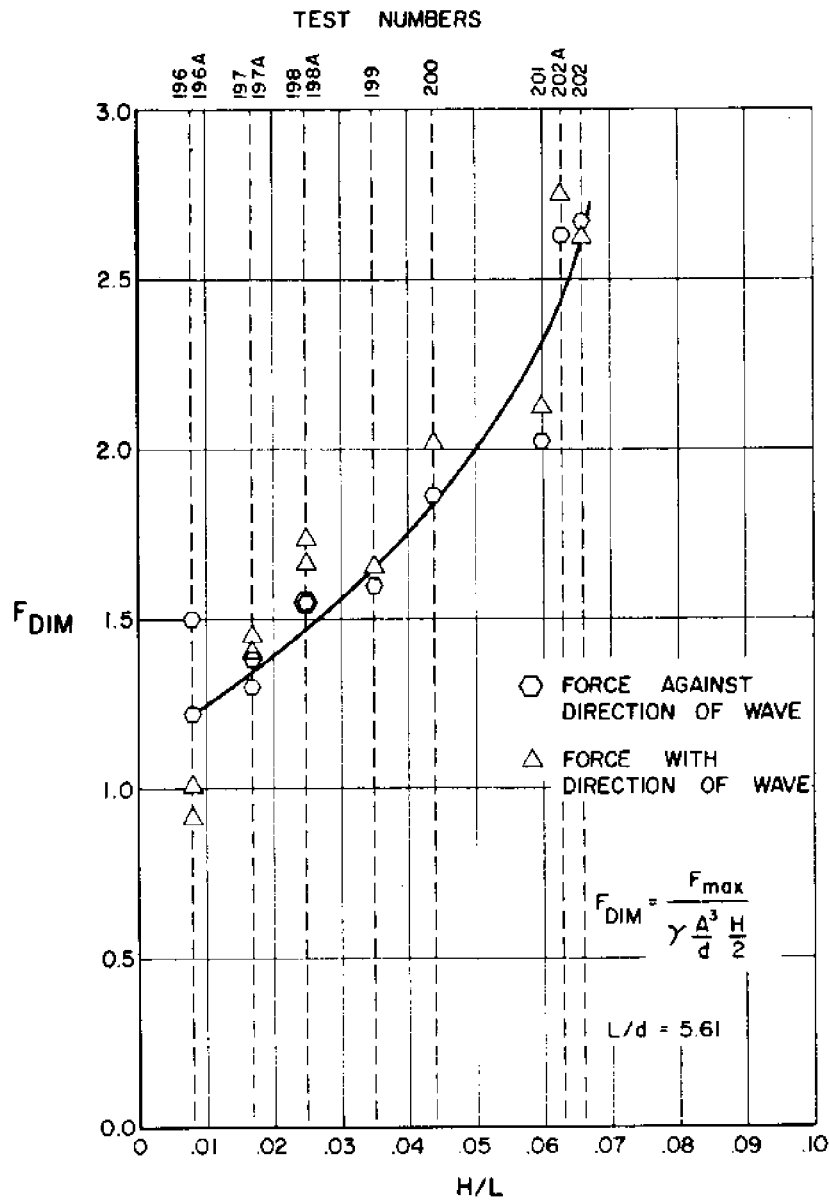

FIG. 12 — SAMPLE DIMENSIONLESS HORIZONTAL FORCE PLOT FOR FLAT PLATE.
L/d = 5.61

inputs to this solution were the same as those cited above for dimensionless force computation. The program increased the values of C_d and C_m by iteration. This was done by iterating larger values of C_d , then holding them constant, and comparing the total measured force and the computed total force for increasing values of C_m . When the measured force and computed force approximate each other, the computed value of C_m is given. In the case where drag force is significant the best values of C_d and C_m can be selected by picking the values which remain more or less constant with changing wave parameters. For the flat plate and two inch long rectangular model, the volume of a circumscribing cylinder was used for the computations. It was found that drag forces were small in the case of the 5/8 inch thick flat plate. A value of 3.5 for C_d was suggested by Brater, McNown and Stair (1). Using this value, the drag force represented less than 5 percent of the total force for waves of small steepness and 10 percent of the total force for waves of large steepness. Apparently, the finite thickness of the plate was enough to make inertial force predominant. Due to the small size of the drag forces it was impossible to evaluate drag coefficient. For all models except the flat plate, the drag force was insignificant. The computer program which applies the Morison Equation to determine drag and inertial coefficients and a sample of computer output are presented in Appendix VIII.

Since forces on all the models are largely inertial, the

values of coefficient of inertia were computed following the methods suggested by Reid and Bretschneider (15). A computer program was used which utilized the same inputs as those cited above for dimensionless force computation. The program determined C_m by use of Eq. 40. Values of C_m were increased by iteration until measured force and the computed force approximated each other. This method was used to determine inertial coefficients for all models except the flat plate. The computer program which computes C_m utilizing Eq. 40 and a sample of computer output are presented in Appendix VI. The subprogram titled "Force-2" performs this function. The program was modified to sum a series of thin rectangular solids to accommodate the half cylinder model, as it was not of constant cross section in the direction of wave travel. This program can be applied to any large submerged object of irregular cross section. The program thus modified and a sample of computer output are presented in Appendix VII. The subprogram "Force-4" performs this function. The results of calculation of C_m by Eq. 40 are presented graphically in Appendix III. These curves indicate that the coefficients of inertia show a small variation with L/d and H/L ratios. In general the coefficient was higher for higher values of H/L . There was also some variation of C_m with L/d as indicated in the curves. The values of coefficient C_m varied between 1.20 and 2.20 for all tests.

Methods suggested by Reid and Bretschneider (15) were used to compare the computed and experimental values. Several values of

C_m were selected for this comparison. The computation utilized Eq. 40 to determine the calculated force for a given C_m . Subprogram "Force-1" performed this computation in the computer program for objects of regular cross section. This program is presented in Appendix VI. Subprogram "Force-3" performed this computation in the computer program for objects of irregular cross section. This program is presented in Appendix VII. The results of the comparison of measured force and calculated force are presented in tabular form in Appendix IV. The best correlation of the computed and experimental data for the two-inch long model was obtained with a value of C_m of 1.40. The best correlation for all other models was obtained with a value of C_m of 1.80.

CONCLUSIONS AND RECOMMENDATIONS FOR FURTHER RESEARCH

It was found that force was a regular function of steepness (H/L) and relative wave length (L/d). The force increased for increasing values of either parameter. The general shape was the same for all curves of steepness versus dimensionless force. The shape of all relative wave length versus dimensionless force was similar. As the data is in dimensionless form, it can be extrapolated to prototypes of similar shape.

The data was analyzed utilizing the Morison Equation. It was found that drag force was small for a flat plate of finite thickness and negligible for models with larger volumes. The inertial portion of the Morison Equation and equations derived from it were used for analysis of forces and determination of inertial coefficient. The coefficients of inertia varied little with changes in relative wave length and steepness. In general the coefficient was slightly higher for higher steepnesses. The values of inertial coefficient varied between 1.20 and 2.20 for all tests. Values of C_M in this range were used to compute force. This force was compared to the measured values. The best correlation for the shortest (in the direction of wave travel) model was obtained with a value of C_M of 1.40. The best correlation for all other models was obtained with a value of C_M of 1.80.

As the flat plate tested yielded primarily inertial forces,

future experiments should include tests of a thinner plate. This would facilitate evaluation of drag coefficient.

Prototypes are exposed to the irregular gravity waves of the sea, and not the regular ones of the laboratory. For this reason, future research should include tests of models exposed to irregular, wind-generated waves. These tests could be related to existing work by techniques of spectral analysis.

It is also suggested that future tests be conducted in a three-dimensional wave tank to eliminate any possible errors introduced by reflections induced by the walls of a two-dimensional wave channel.

The most valuable future research would be the instrumentation of prototypes and very large models. This has already provided valuable information in the case of offshore platforms. While it is a difficult and expensive proposal, only when prototypes are tested will absolute information about forces on submerged structures be known.

BIBLIOGRAPHY

1. Brater, E. F., McNow, J. S., and Stair, L. D., "Wave Forces on Submerged Structures", Journal of the Waterways and Harbors Division ASCE, Vol. 84, No. HY6, Proc. Paper 1833, November, 1958.
2. Chamberlin, R. S., "Design Considerations-Offshore Storage," Oceanography Conference, Brighton, England, 1969.
3. Commission on Marine Science, Engineering and Resources, "Our Nation and the Sea", Superintendent of Documents, January 1969.
4. Commission on Marine Science, Engineering and Resources, "Science and Environment," Vols. 1-3, Superintendent of Documents, February 1969.
5. Crooke, R. C., "Re-analysis of Existing Wave Force Data on Model Piles," T. M. 71, Beach Erosion Board, U. S. Army Engineers, 1955.
6. Evans, D. J., "Analysis of Wave Force Data," Journal of Petroleum Technology, Vol. 22, March, 1970.
7. Ippen, A. T., Editor, Estuary and Coastline Hydrodynamics, McGraw-Hill Co., New York, 1966.
8. Itokawa, H., "Undersea Oil Storage System," Technical Research Society for Undersea Oil Storage, Tokyo, Japan, 1969.
9. Keulegan, G. H., and Carpenter, L. H., "Forces on Cylinders and Plates in an Oscillating Fluid", Journal of Research of the National Bureau of Standards, Vol. 60, No. 5, May 1958, pp. 423-440.
10. Morison, J. R., O'Brien, M. P., Johnson, J. W., Schaaf, S. A., "The Force Exerted by Surface Waves on Piles", Petroleum Trans., Amer. Inst. Mining Engrs., Vol. 189, 1950, pp. 149-154.
11. Morison, J. R., "The Design of Piling," Proc. 1st Conference on Coastal Engineering, pp. 254-258, 1951.
12. Morison, J. R., Johnson, J. W., and O'Brien, M. P., "Experimental Studies of Forces on Piles", Proc. Fourth Conf. on Coastal Eng., 1954, pp. 340-370.

13. O'Brien, M. P., and Morison, J. R., "The Forces Exerted by Waves on Objects", Trans. Amer. Geophys. Union, Vol. 33, No. 1, February, 1952.
14. Office of the Oceanographer of the Navy, "The Ocean Engineering Program of the U. S. Navy," September 1967.
15. Reid, R. O., and Bretschneider, C. L., "Surface Waves and Offshore Structures: The Design Wave in Deep or Shallow Water, Storm Tide, and Forces on Vertical Piles and Large Submerged Objects", Technical Report, Agricultural and Mechanical College of Texas, Department of Oceanography, October, 1953.
16. Wiegel, R. L., Oceanographical Engineering, Prentice-Hall, Englewood Cliffs, N. J., 1964.
17. Wilson, B. W., and Reid, R. O., "Discussion of Wave Force Coefficients for Offshore Pipelines", Journal of the Waterways and Harbors Division ASCE, Vol. 89, WW1, February, 1963.

APPENDICES

APPENDIX I

NOTATION

The following symbols are used in this paper:¹

<u>Symbol</u>	<u>Quantity</u>	<u>Dimension</u>
a	Wave amplitude = $H/2$	L
A	Significant linear dimension equal to height of the model squared divided by length of model in direction of wave propagation for all models except flat plate	L
A	Height of model for flat plate	L
C	Celerity	L/T
d	Water depth	L
F_D	Force due to drag	ML/T^2
F_{DIM}	Dimensionless force	-
F_h	Horizontal force	ML/T^2
F_I	Force due to inertia	ML/T^2
F_{max}	Maximum force measured	ML/T^2
g	Gravity	L/T^2
H	Wave height	L
H_m	Height of model	L
K	Pressure coefficient	-

¹These symbols are consistent throughout the thesis with the exception of the literature survey. In the literature survey, symbols are used as they appear in the cited literature, and are redefined for each author.

<u>Symbol</u>	<u>Quantity</u>	<u>Dimension</u>
k	$2\pi/L$	$1/L$
L	Wave length	L
L_m	Length of model	L
L_0	Deep water wave length	L
P	Gauge pressure	M/LT^2
ΔP	Pressure anomaly	M/LT^2
ΔP_1	Pressure anomaly at leading edge of object	M/LT^2
ΔP_2	Pressure anomaly at trailing edge of object	M/LT^2
$(\Delta_p)_c$	Pressure anomaly under the wave crest	M/LT^2
$(\Delta_p)_t$	Pressure anomaly under the wave trough	M/LT^2
T	Wave period	T
t	Time	T
u	Horizontal velocity of water particle	L/T
\dot{u}	Horizontal acceleration of water particle	L/T^2
W_m	Width of model	L
x	The distance from the wave crest measured in the direction of wave travel	L
x_1	Horizontal distance from the wave crest to the edge of the model direction of wave travel	L
z	Distance from still water level	L
γ	Specific weight of water	M/L^2T^2
η	Distance of the free surface from mean water level	L

<u>Symbol</u>	<u>Quantity</u>	<u>Dimension</u>
θ_1	$2\pi x_1/L$	-
ρ	Density	M/L^3
σ	$2\pi/T$	$1/T$
ϕ	Velocity potential	L^2/T

APPENDIX II

DIMENSIONLESS FORCE SUMMARY CURVES

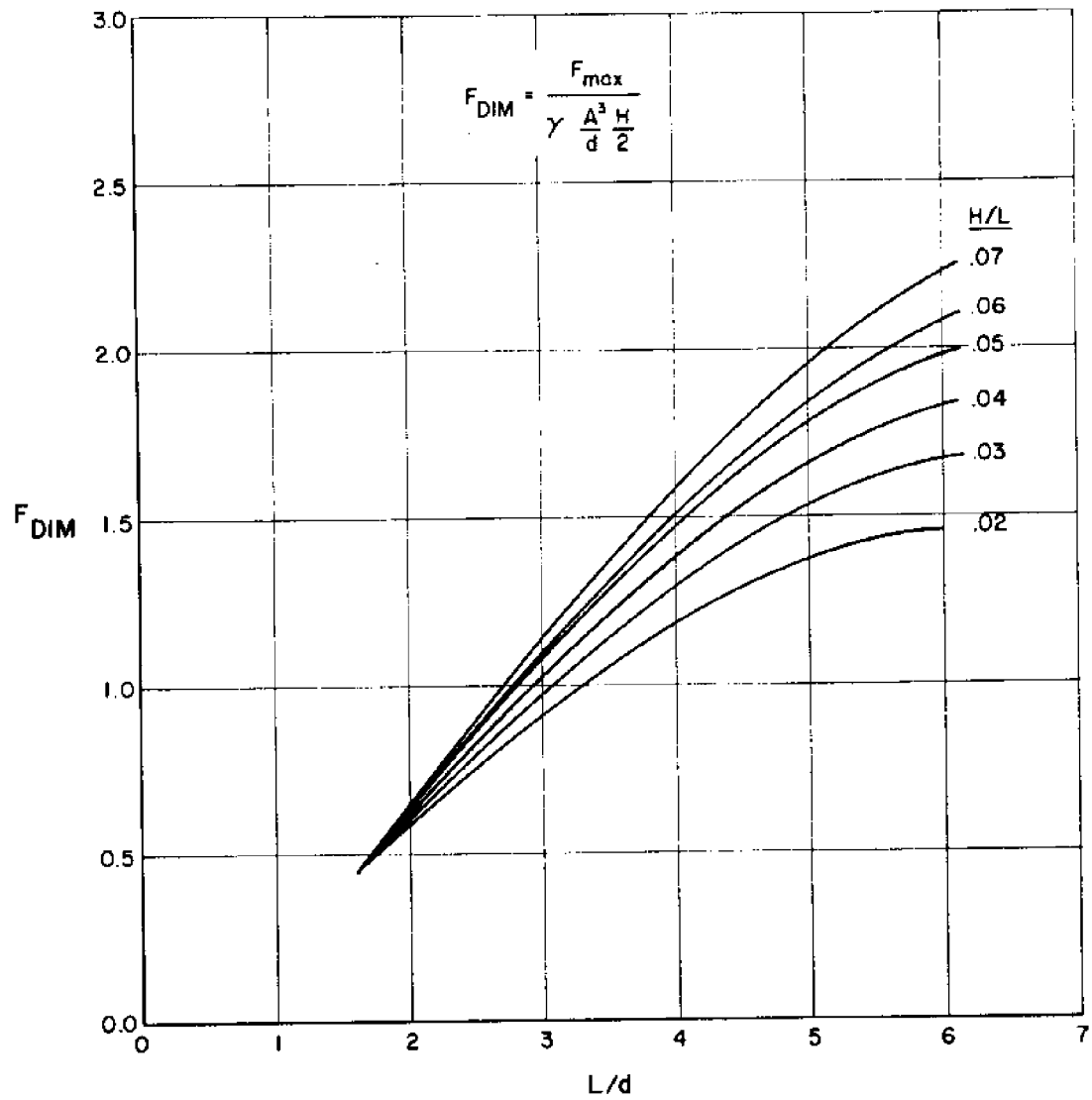

FIG. 13—DIMENSIONLESS HORIZONTAL FORCE PLOT FOR FLAT PLATE.

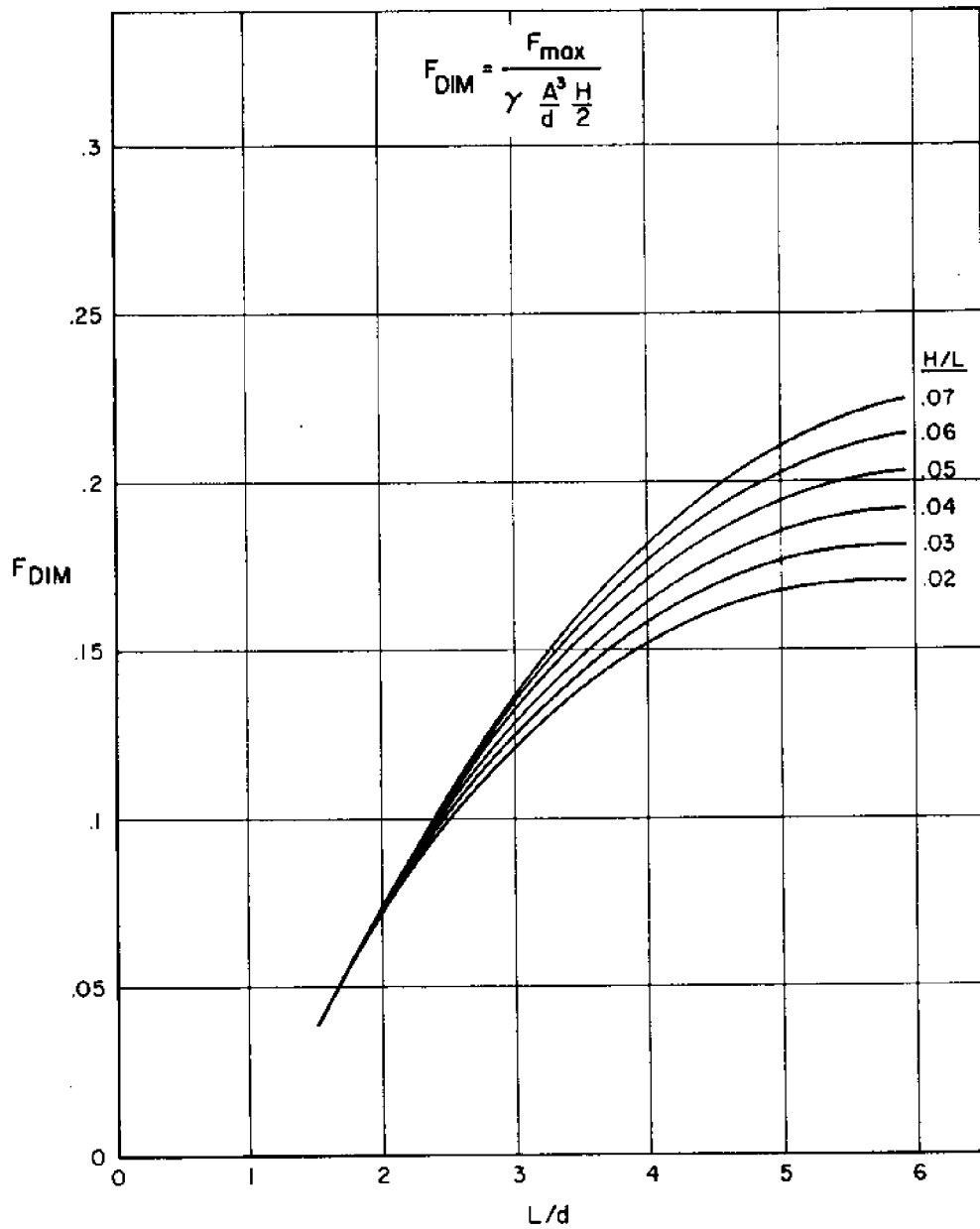

FIG. 14—DIMENSIONLESS HORIZONTAL FORCE (COMPUTED AS A RECTANGULAR MODEL) FOR 2 INCH RECTANGULAR MODEL

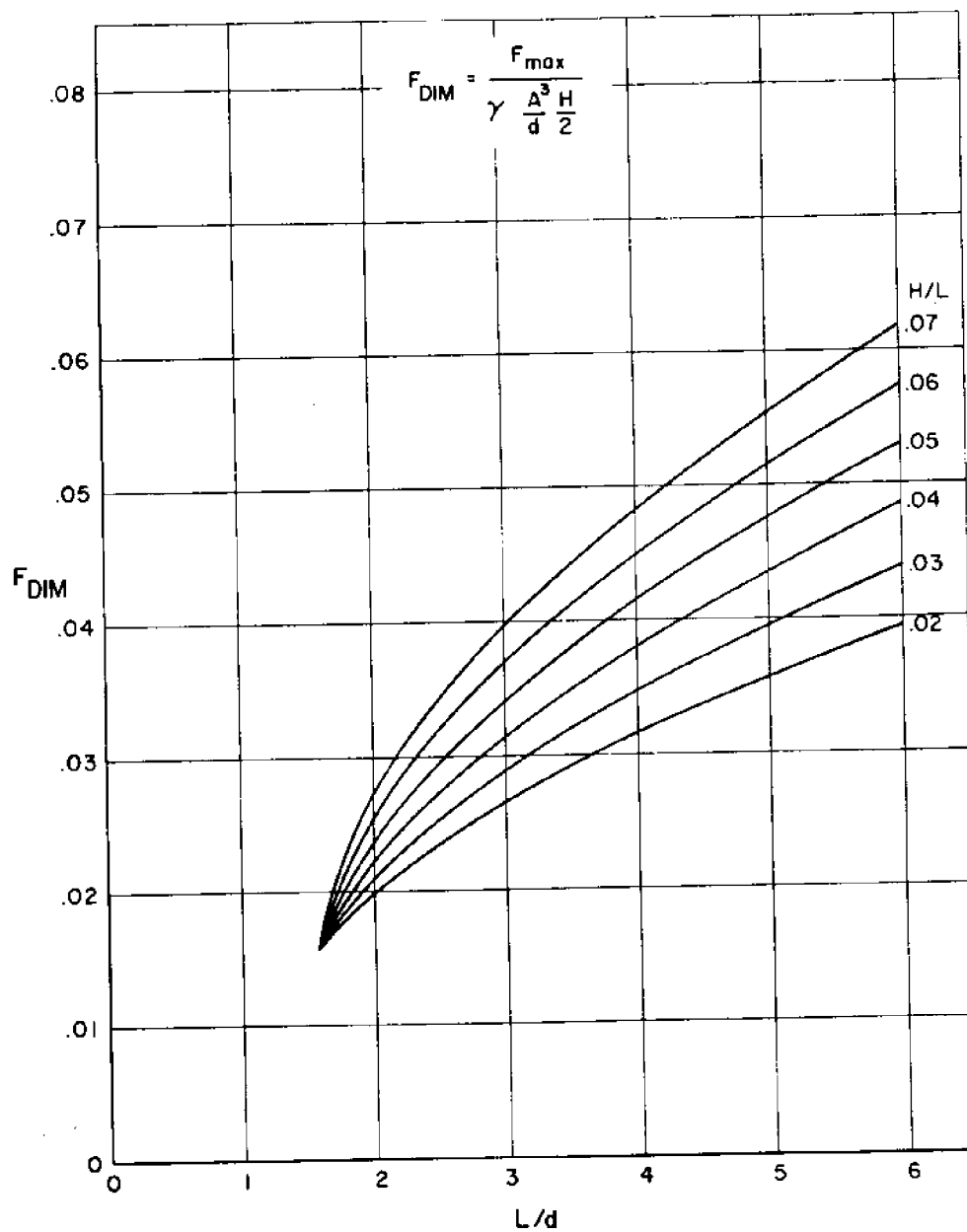

FIG. 15—DIMENSIONLESS VERTICAL FORCE (COMPUTED AS A RECTANGULAR MODEL) FOR 2 INCH RECTANGULAR MODEL

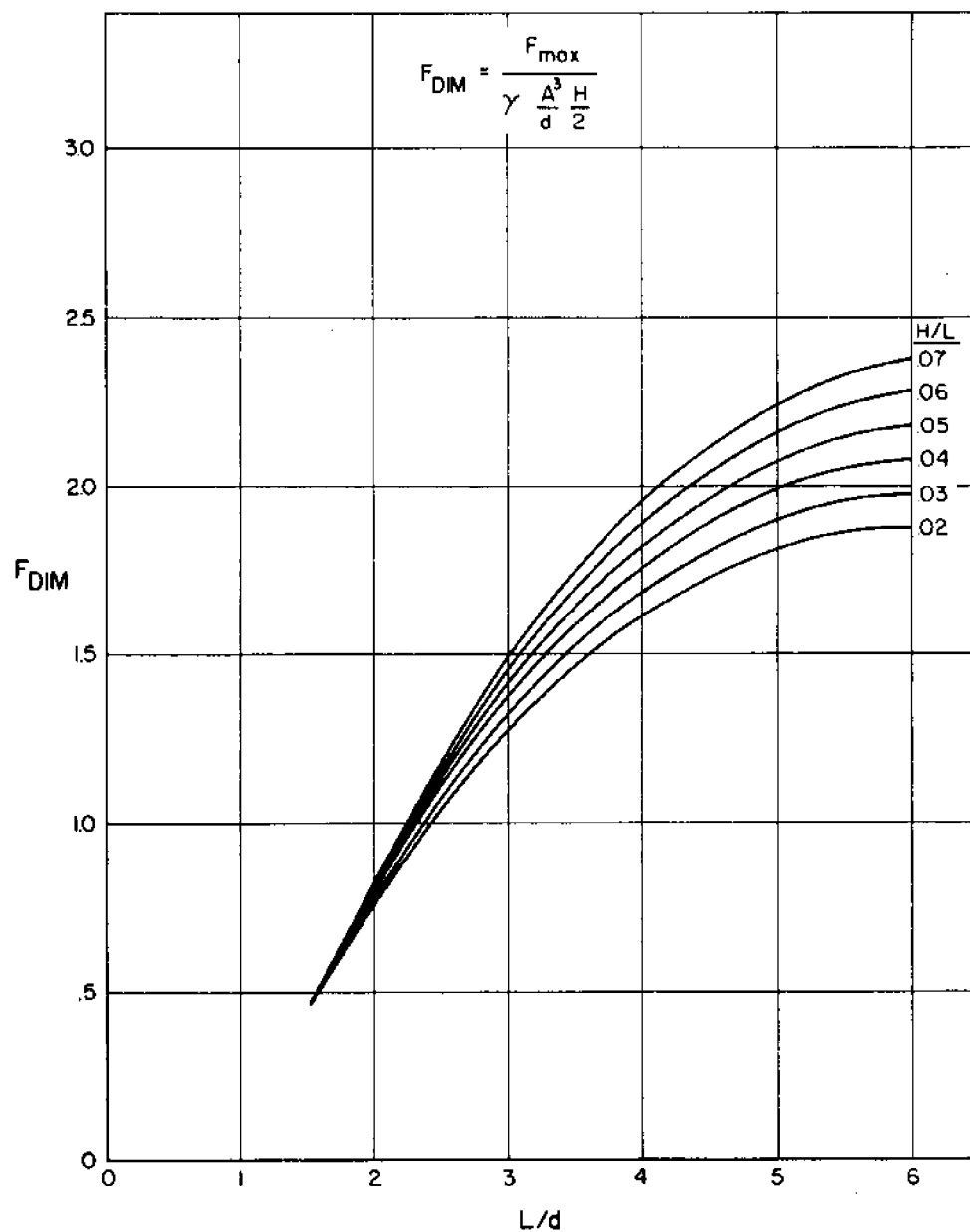

FIG. 16 — DIMENSIONLESS HORIZONTAL FORCE (COMPUTED AS A FLAT PLATE) FOR 2 INCH RECTANGULAR MODEL

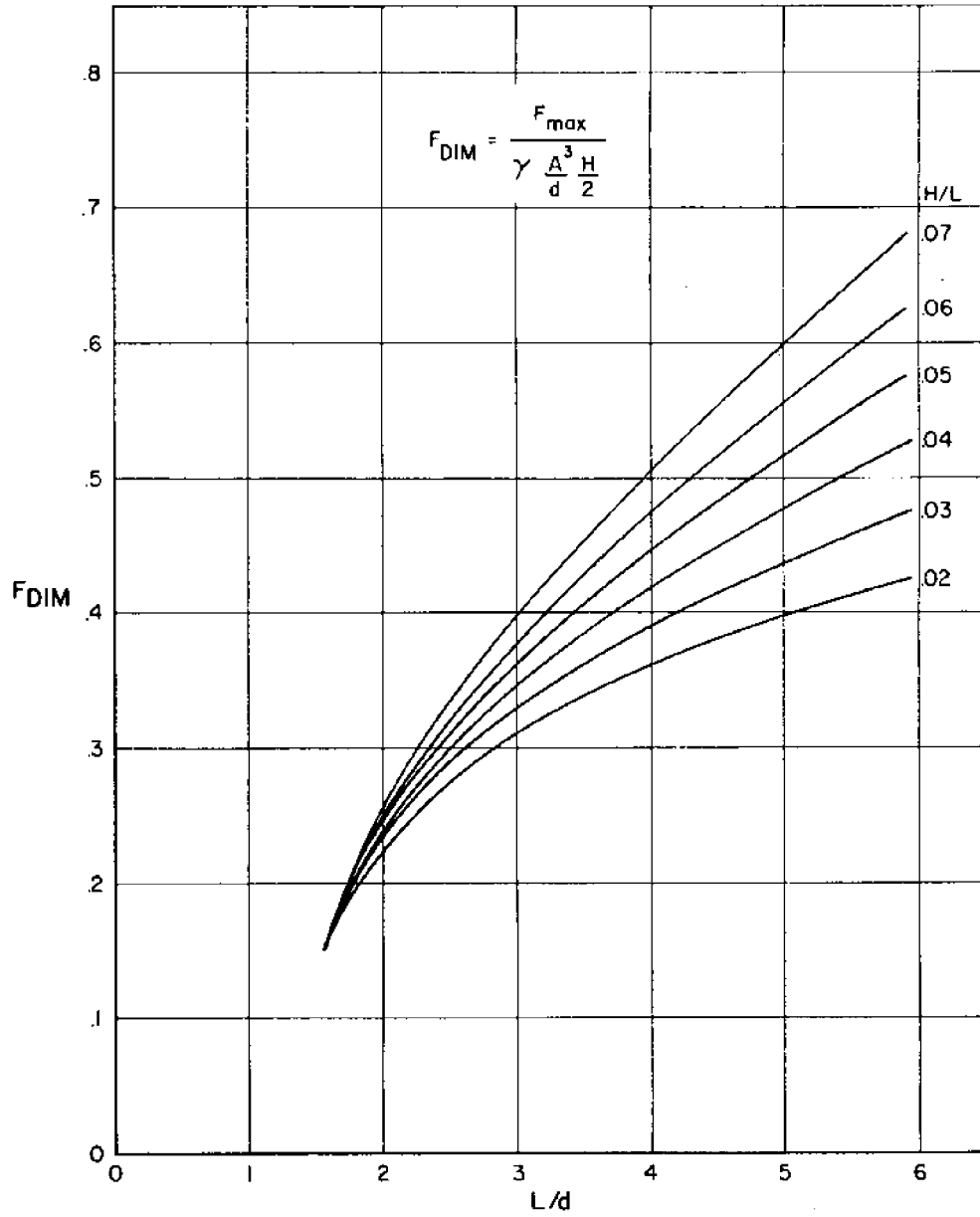

FIG.17—DIMENSIONLESS VERTICAL FORCE (COMPUTED AS A FLAT PLATE) FOR 2 INCH RECTANGULAR MODEL

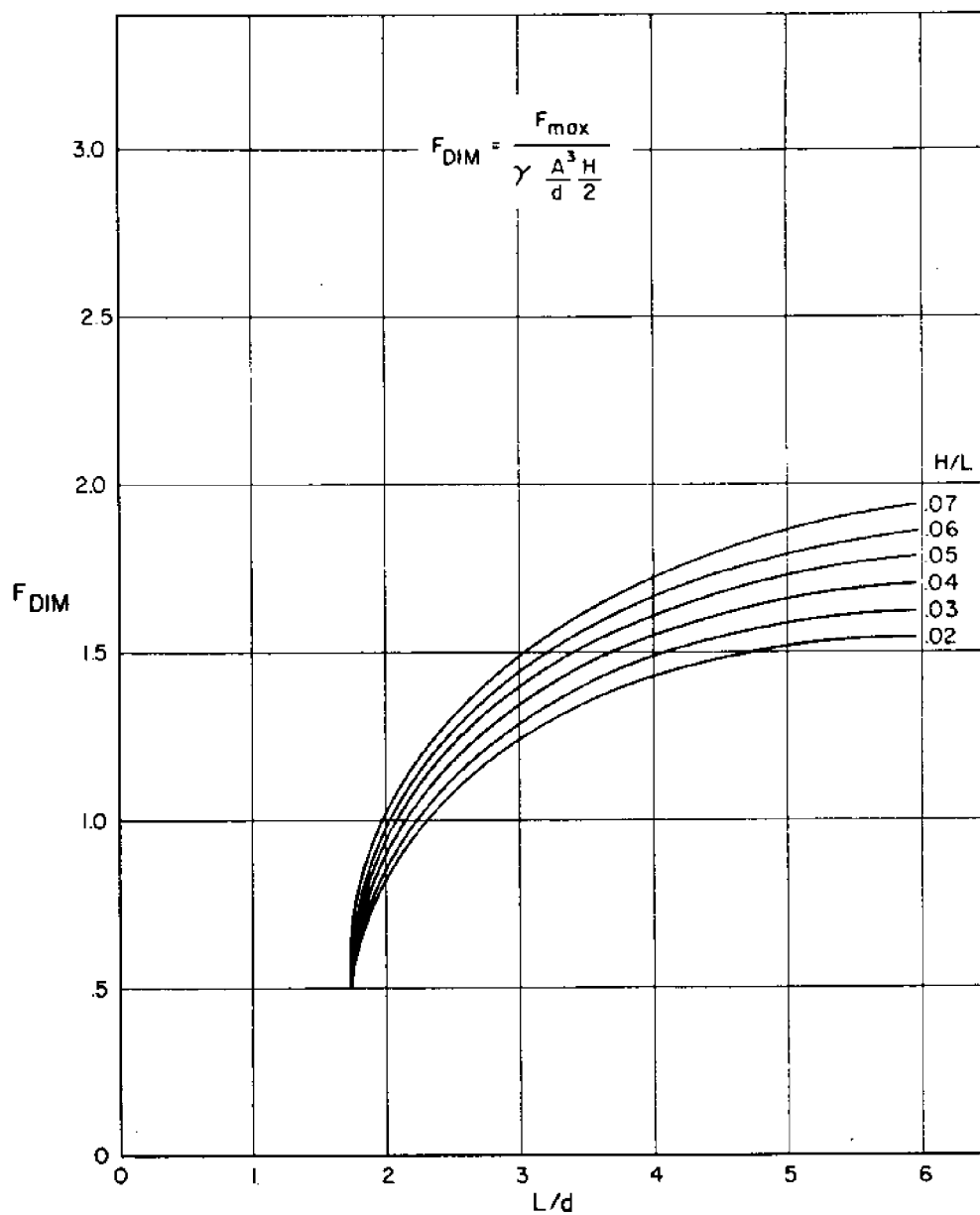

FIG. 18—DIMENSIONLESS HORIZONTAL FORCE FOR 4 INCH RECTANGULAR MODEL

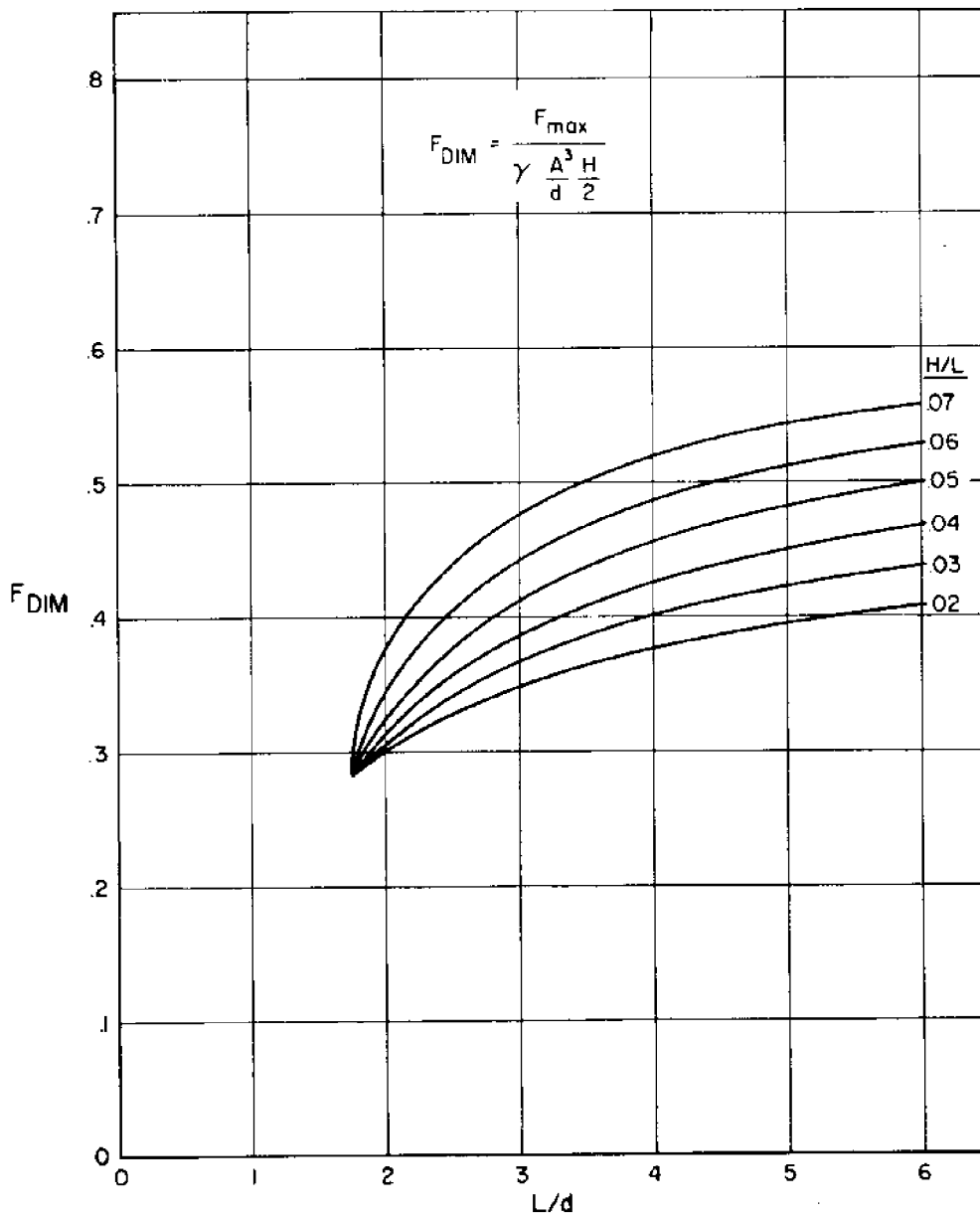

FIG. 19-DIMENSIONLESS VERTICAL FORCE FOR 4 INCH RECTANGULAR MODEL

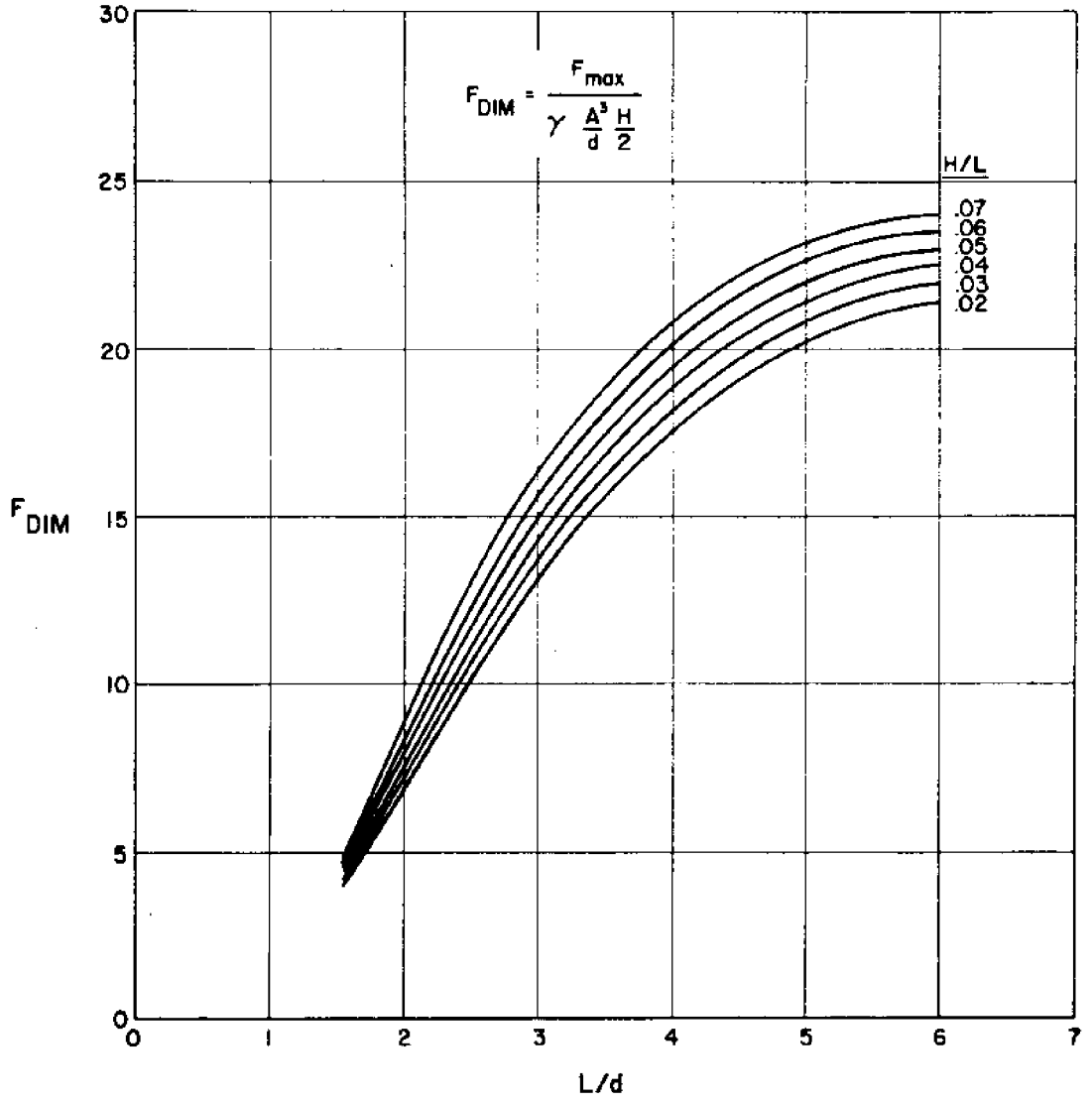

FIG. 20-DIMENSIONLESS HORIZONTAL FORCE FOR 8 INCH RECTANGULAR MODEL

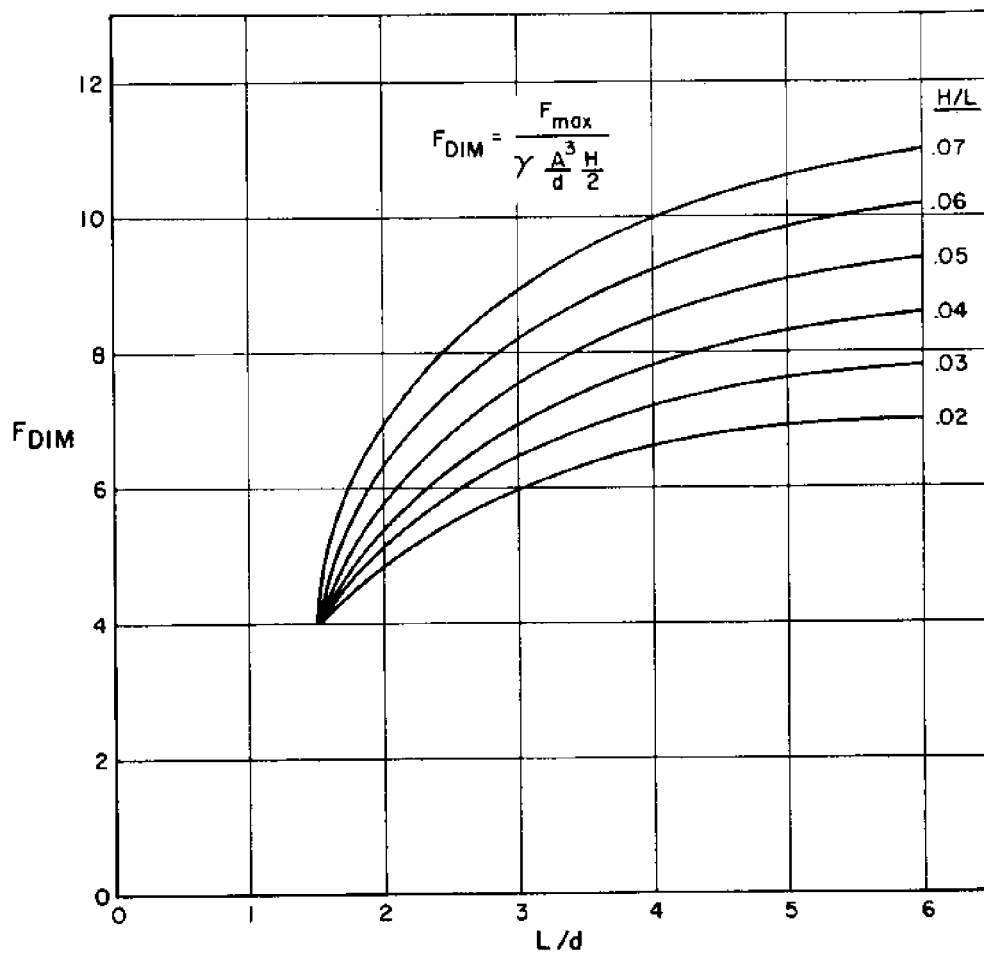

FIG. 21 — DIMENSIONLESS VERTICAL FORCE FOR 8 INCH RECTANGULAR MODEL

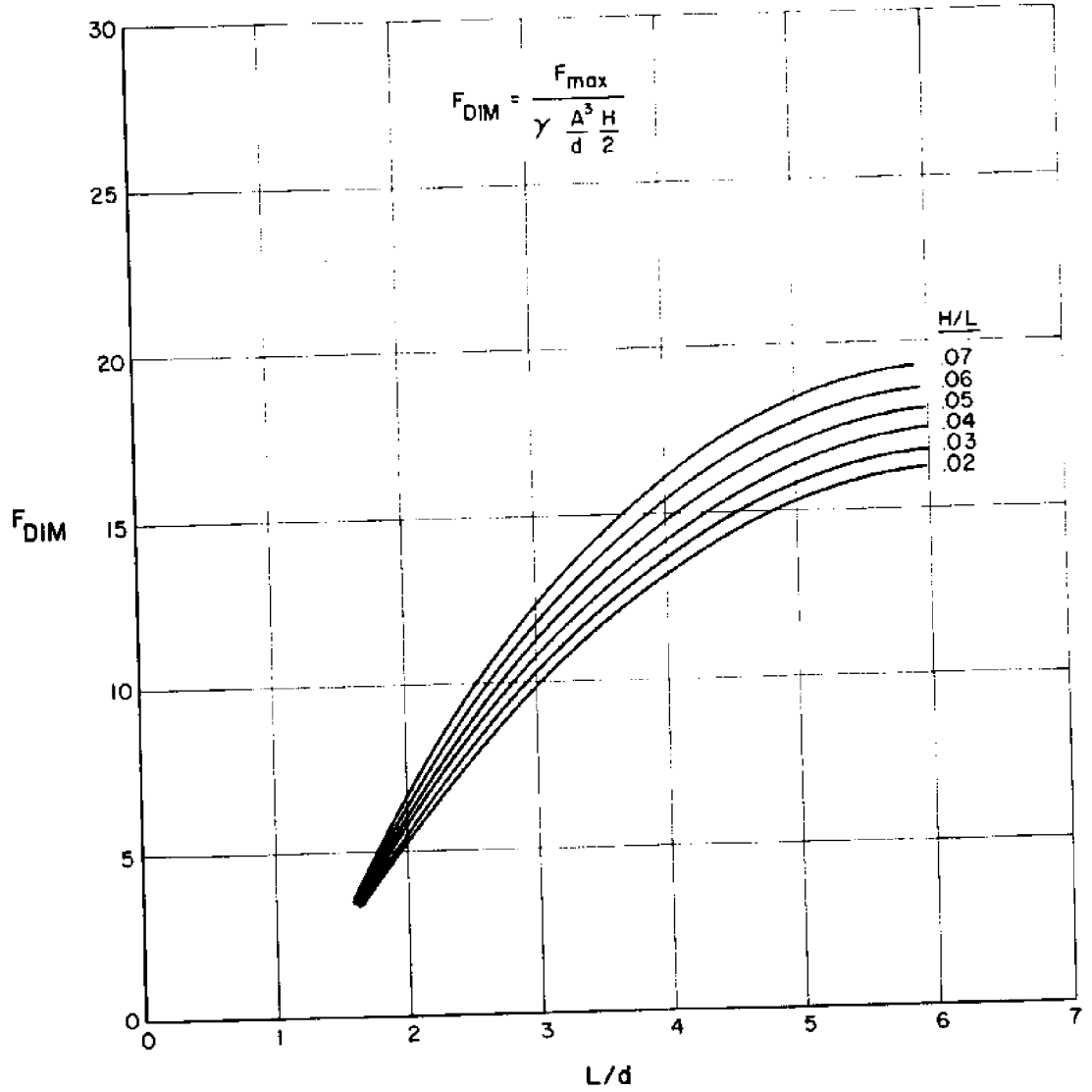

FIG. 22— DIMENSIONLESS HORIZONTAL FORCE PLOT FOR HALF CYLINDER MODEL (END FACING INCIDENT WAVE)

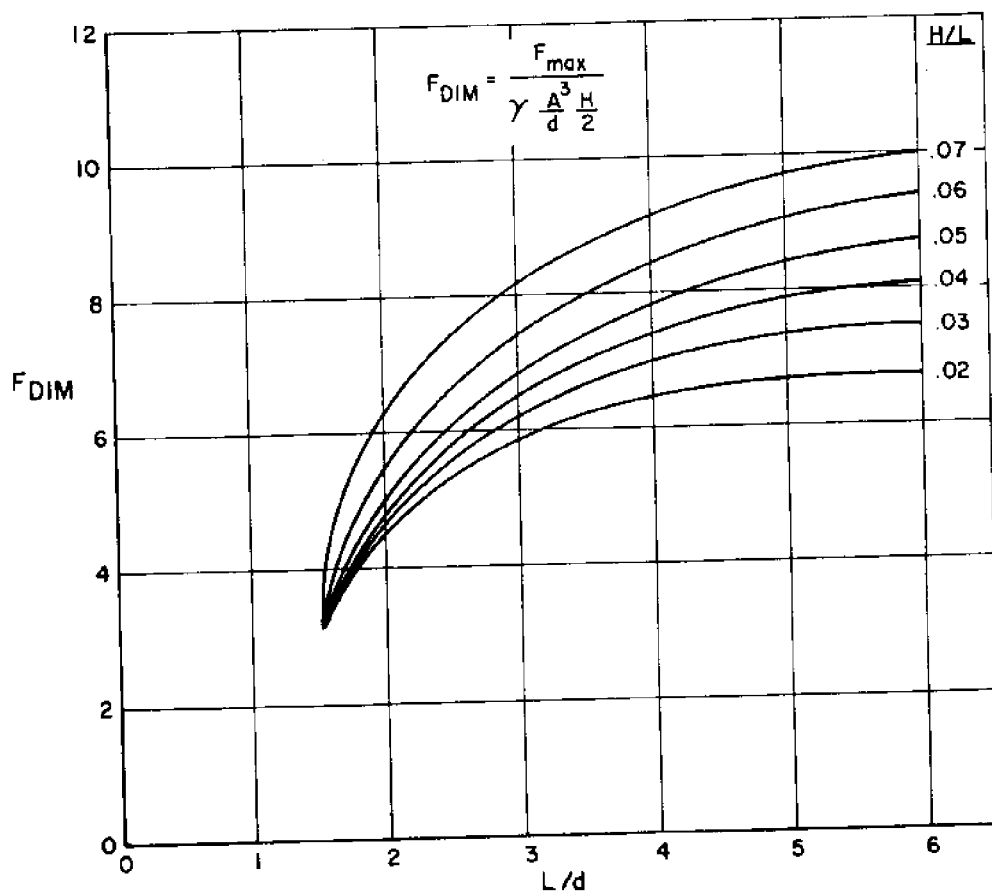

FIG. 23 - DIMENSIONLESS VERTICAL FORCE
PLOT FOR HALF CYLINDER MODEL
(END FACING INCIDENT WAVE)

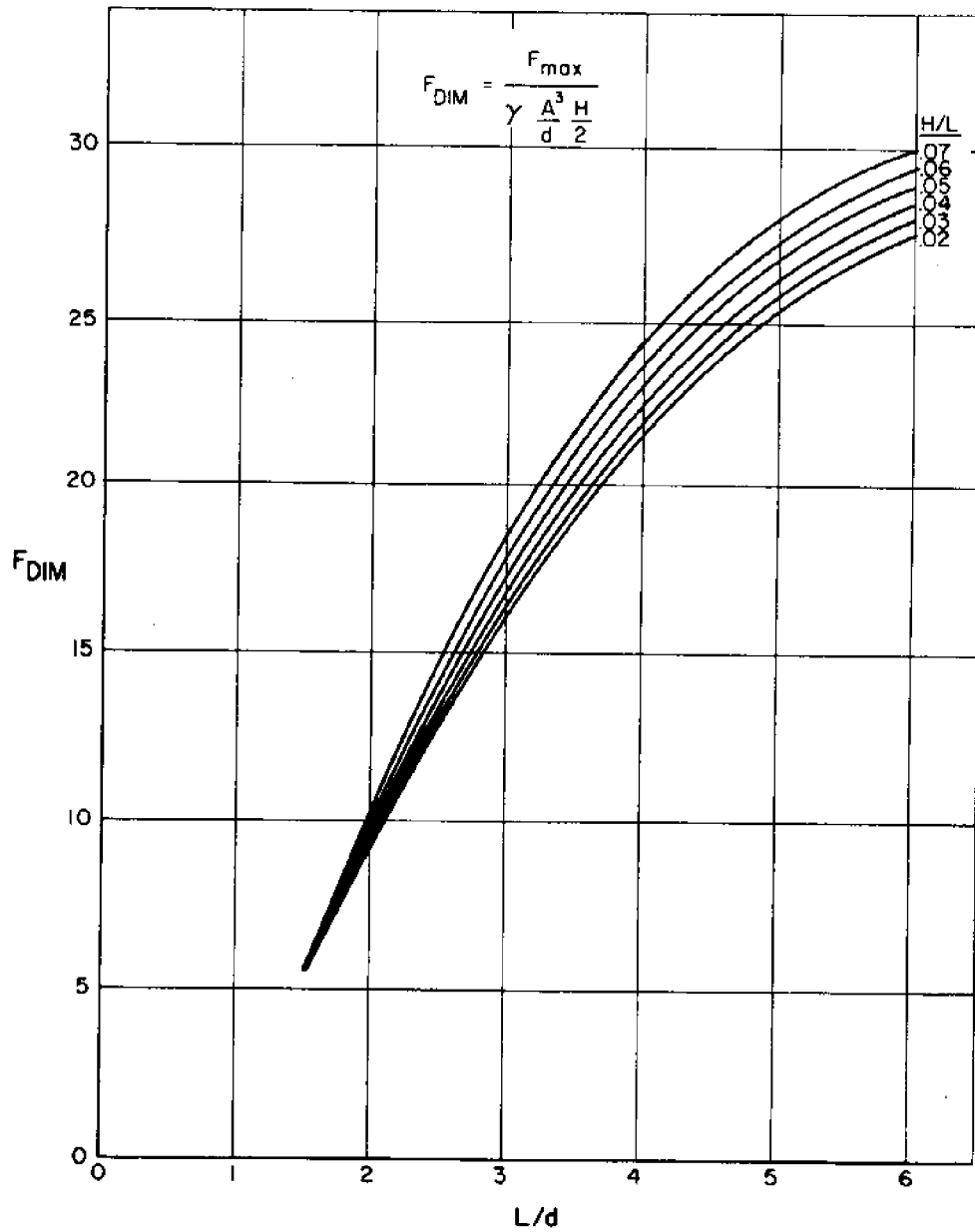

FIG.24-DIMENSIONLESS HORIZONTAL FORCE PLOT FOR HALF CYLINDER MODEL (SIDE FACING INCIDENT WAVE)

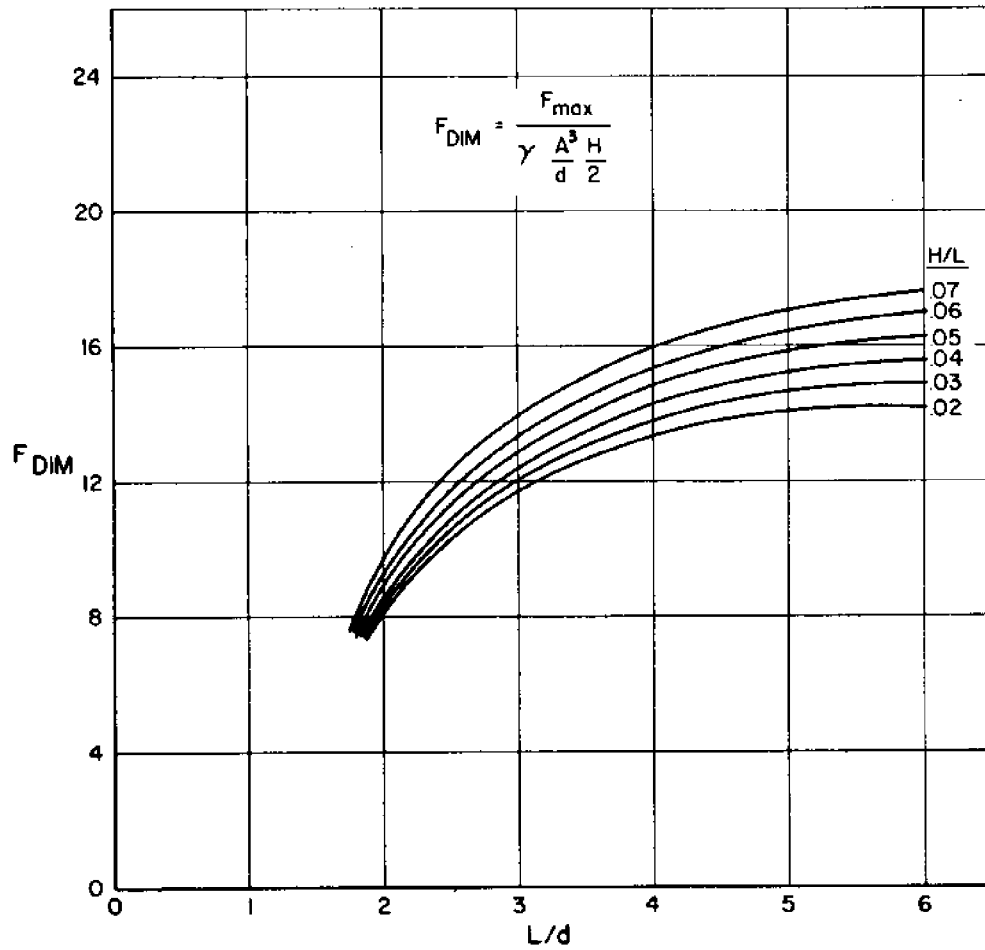

FIG. 25-DIMENSIONLESS VERTICAL FORCE PLOT FOR HALF CYLINDER MODEL (SIDE FACING INCIDENT WAVE)

APPENDIX III

INERTIAL COEFFICIENT CURVES

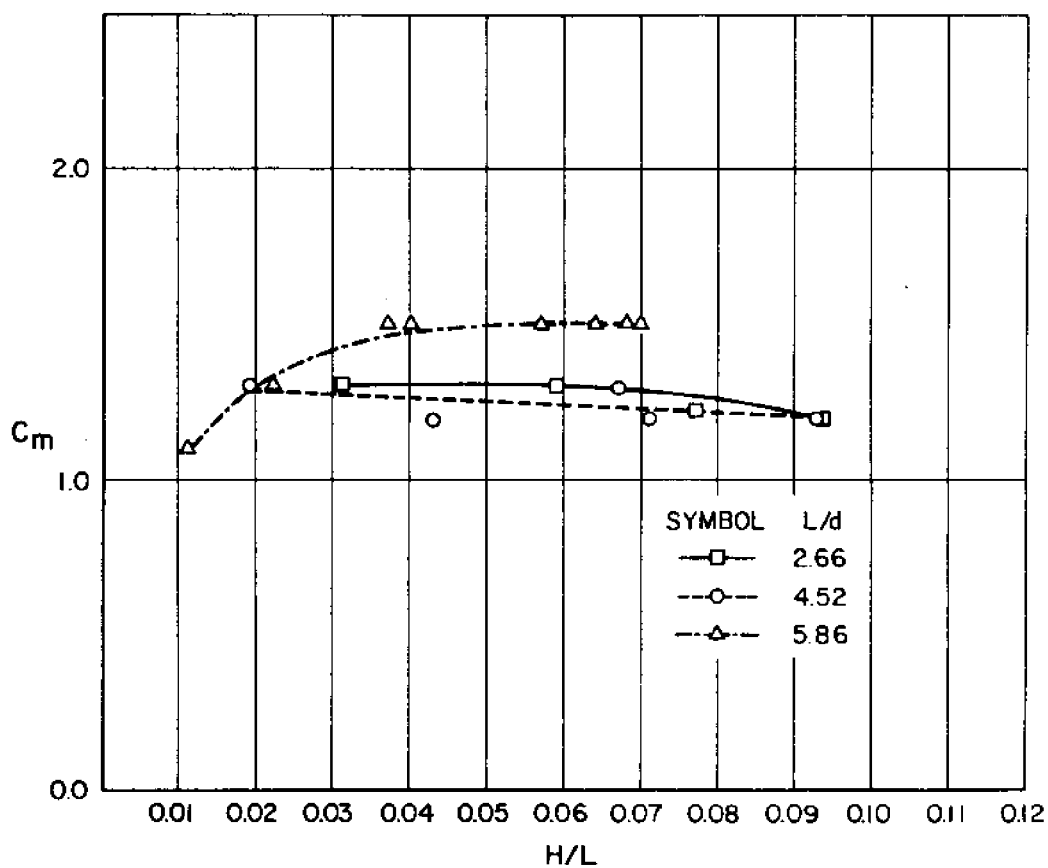

FIG.26-COEFFICIENT OF INERTIA FOR RECTANGULAR MODEL 2-INCHES LONG (WATER DEPTH 13 INCHES)

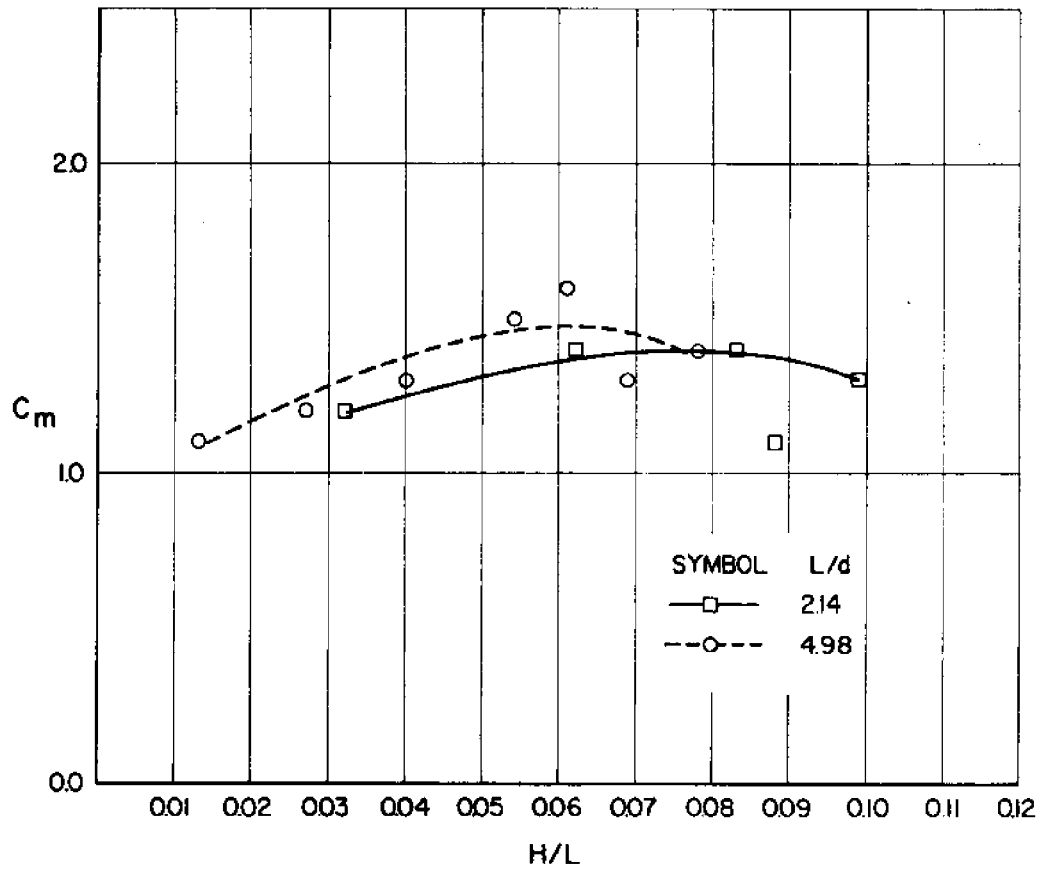

FIG. 27 - COEFFICIENT OF INERTIA FOR RECTANGULAR MODEL 2-INCHES LONG (WATER DEPTH 18 INCHES)

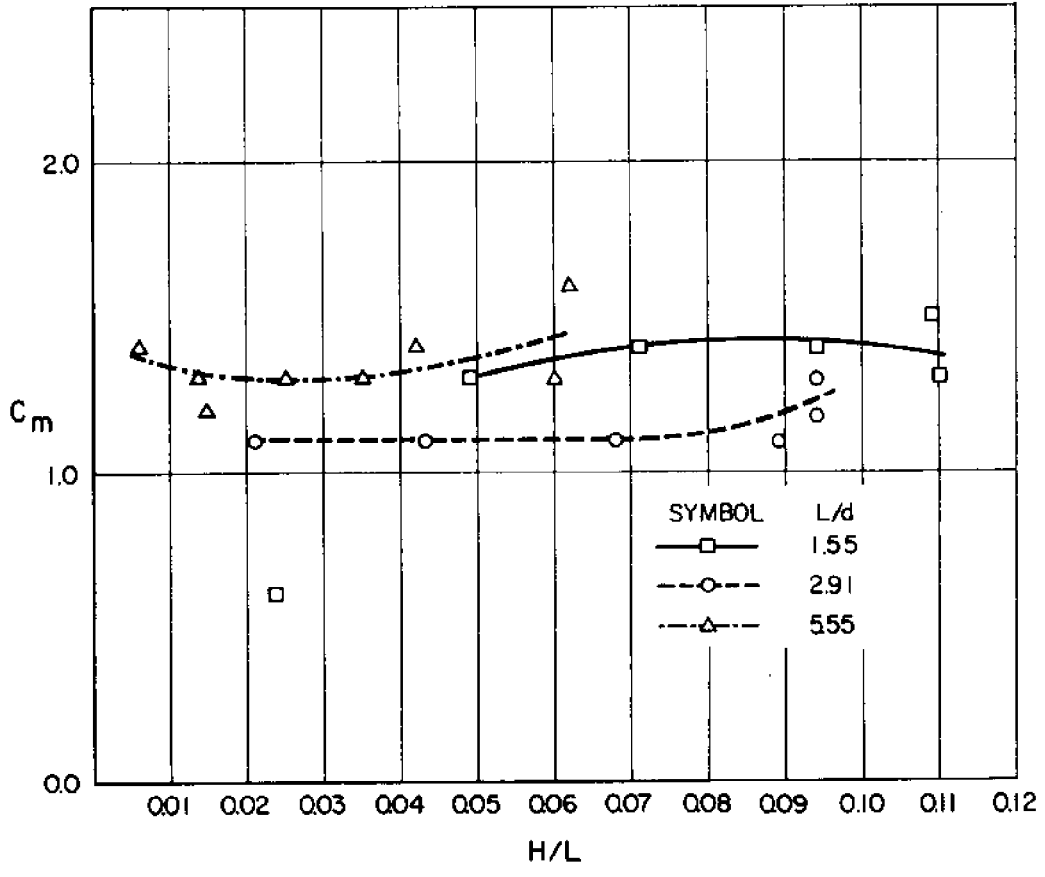

FIG. 28 - COEFFICIENT OF INERTIA FOR RECTANGULAR MODEL 2-INCHES LONG (WATER 24 INCHES)

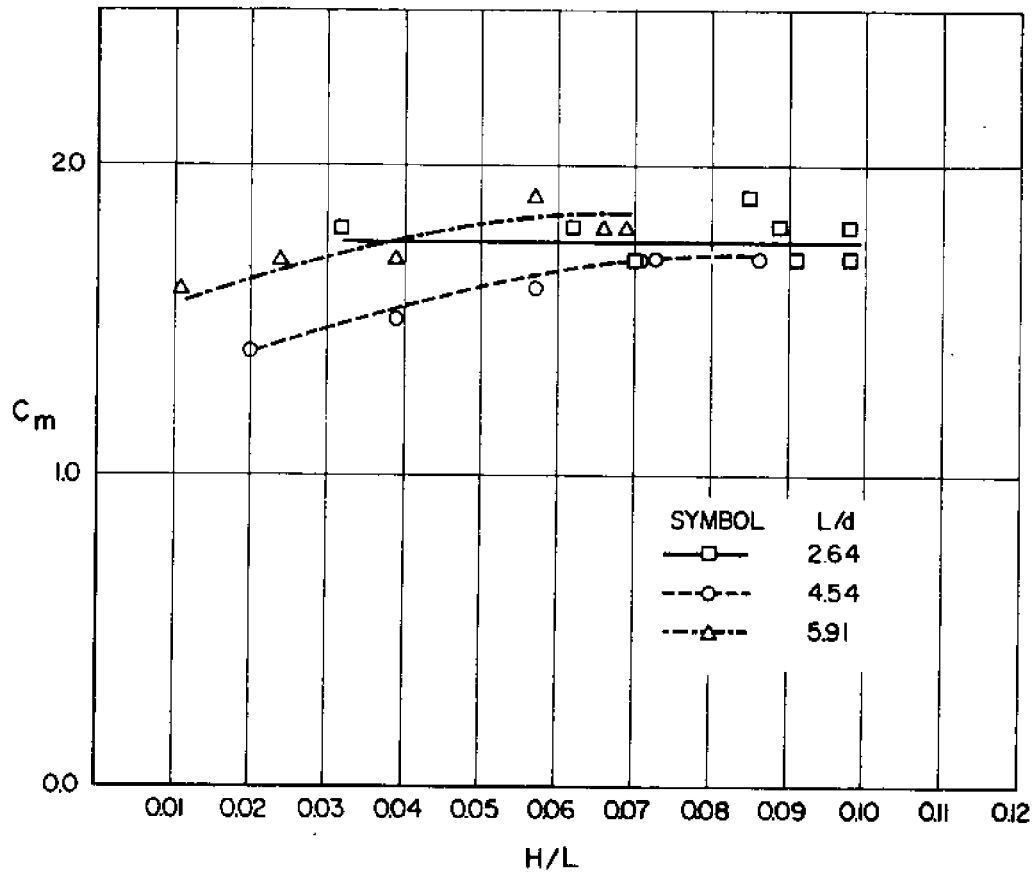

FIG. 29— COEFFICIENT OF INERTIA FOR RECTANGULAR MODEL 4 - INCHES LONG (WATER DEPTH 13 INCHES)

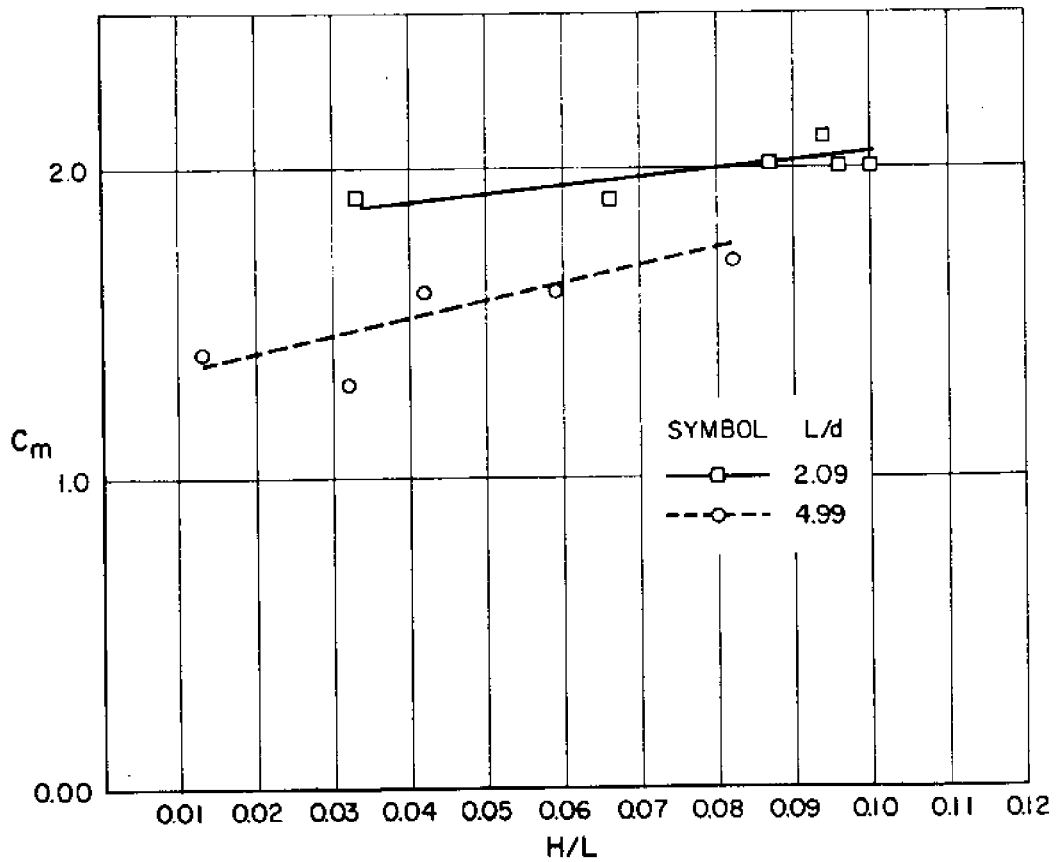

FIG. 30—COEFFICIENT OF INERTIA FOR RECTANGULAR MODEL 4-INCHES LONG (WATER DEPTH 18 INCHES)

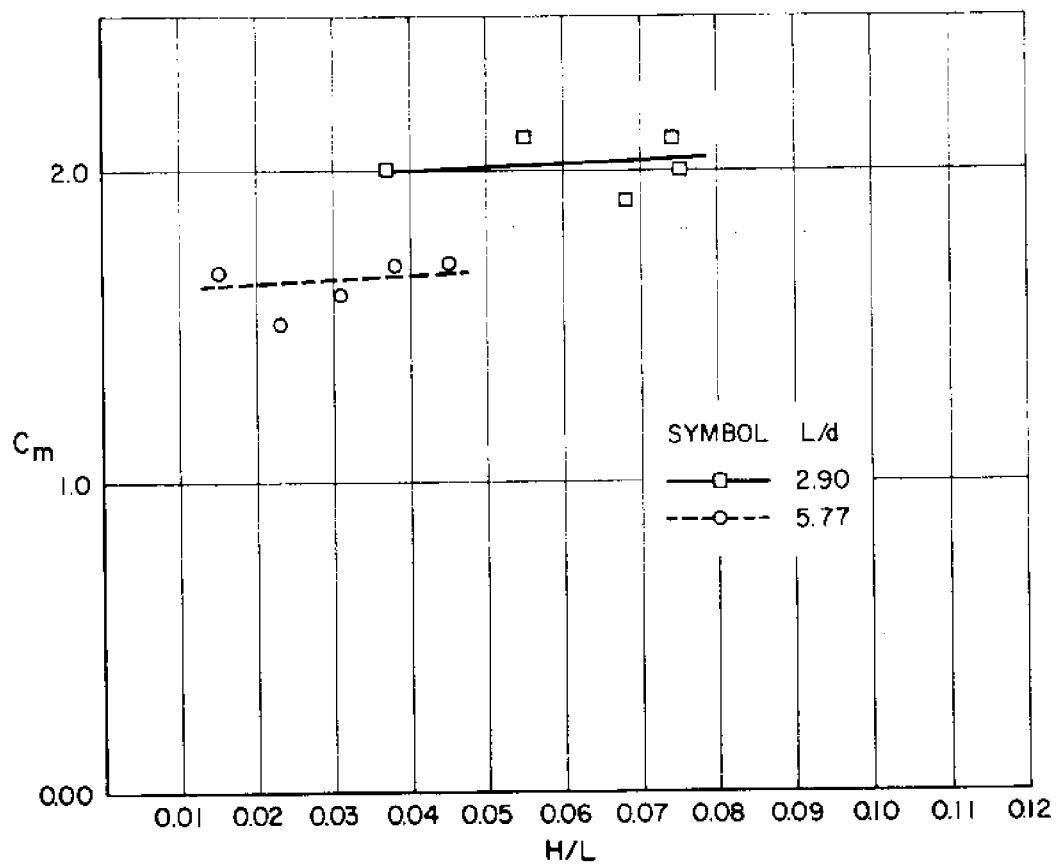

FIG. 31— COEFFICIENT OF INERTIA FOR RECTANGULAR MODEL 4-INCHES LONG (WATER DEPTH 24 INCHES)

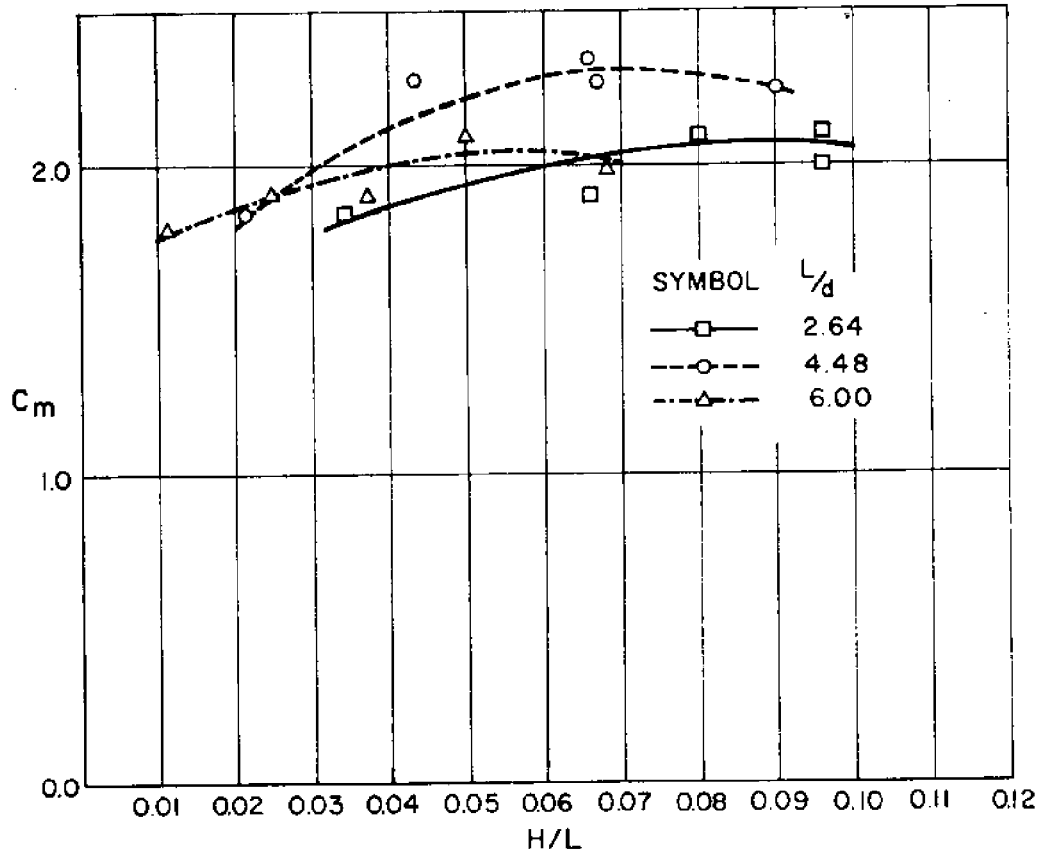

FIG. 32 — COEFFICIENT OF INERTIA FOR RECTANGULAR MODEL 8-INCHES LONG (WATER DEPTH 13 INCHES)

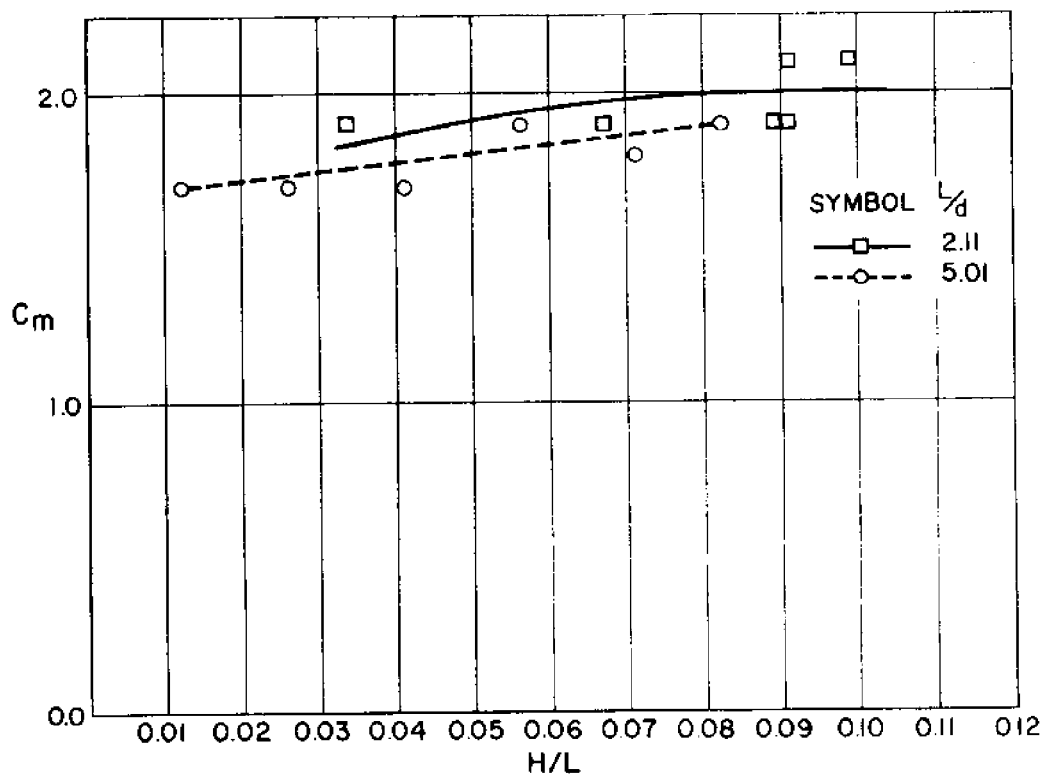

FIG. 33 — COEFFICIENT OF INERTIA FOR RECTANGULAR MODEL 8-INCHES LONG (WATER DEPTH 18 INCHES)

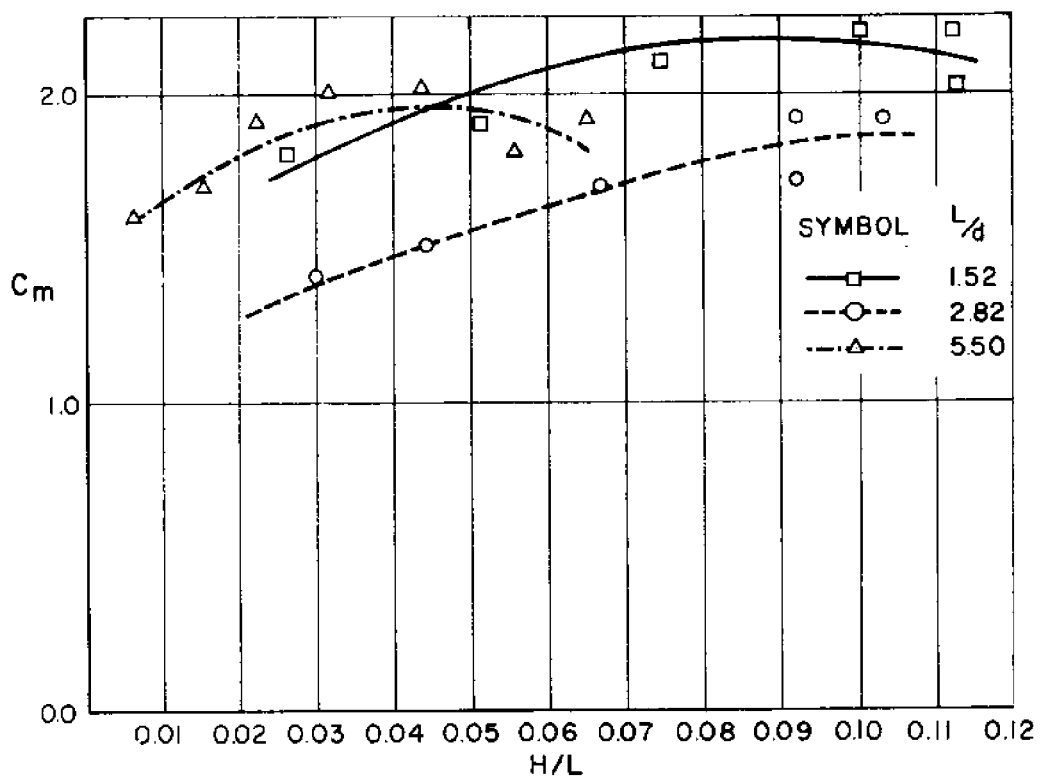

FIG. 34 — COEFFICIENT OF INERTIA FOR RECTANGULAR MODEL 8-INCHES LONG (WATER DEPTH 24 INCHES)

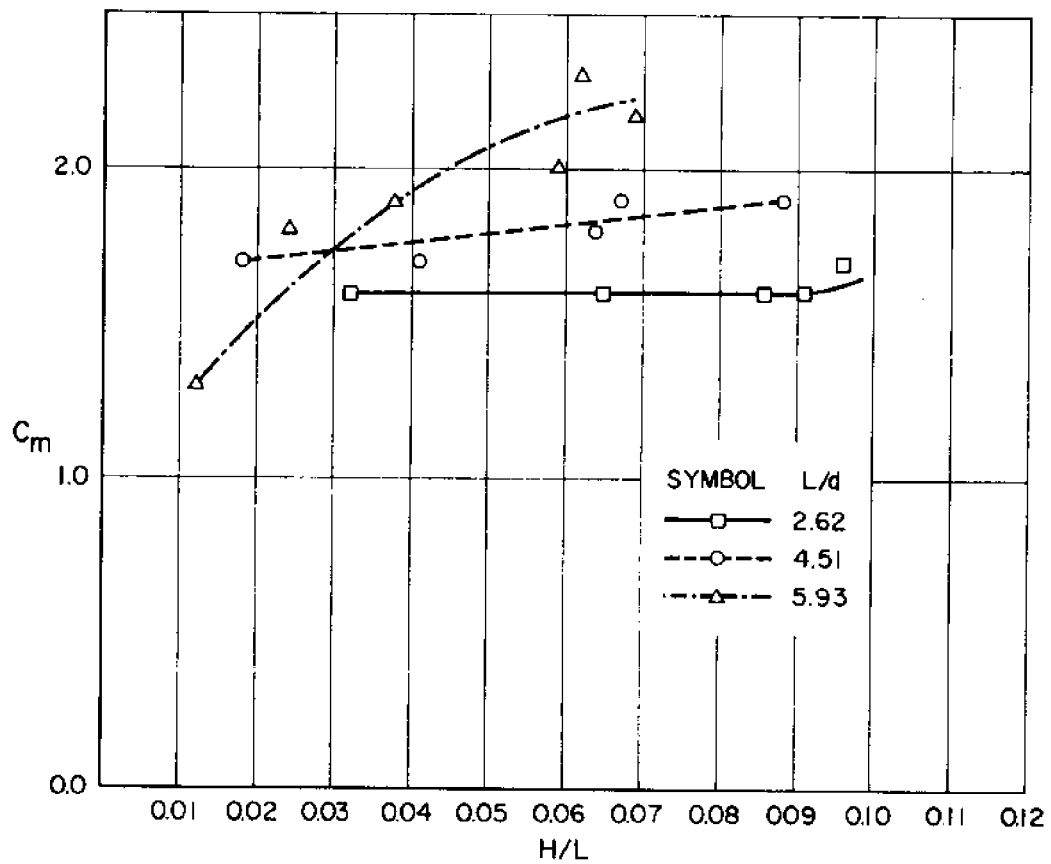

FIG. 35—COEFFICIENT OF INERTIA FOR HALF CYLINDER MODEL (END FACING INCIDENT WAVE, WATER DEPTH 13 INCHES)

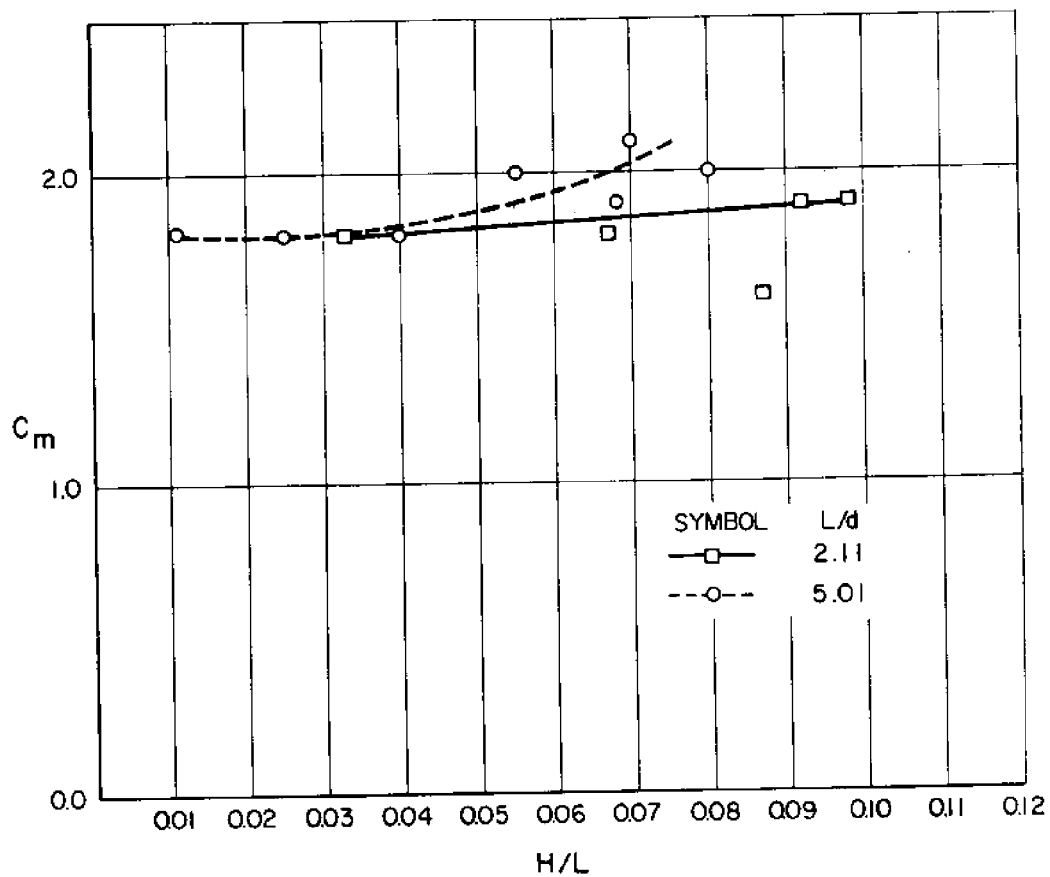

FIG. 36—COEFFICIENT OF INERTIA FOR HALF CYLINDER MODEL (END FACING INCIDENT WAVE WATER DEPTH 18 INCHES)

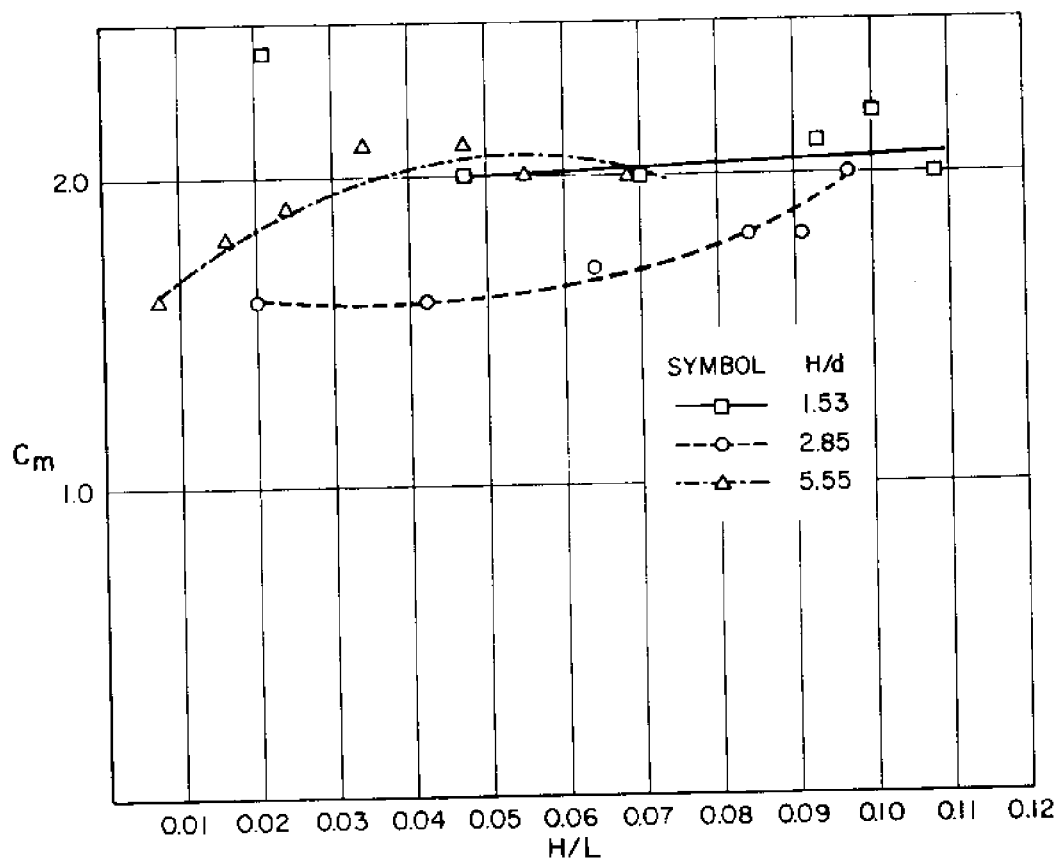

FIG. 37—COEFFICIENT OF INERTIA FOR HALF CYLINDER MODEL (END FACING INCIDENT WAVE, WATER DEPTH 24 INCHES)

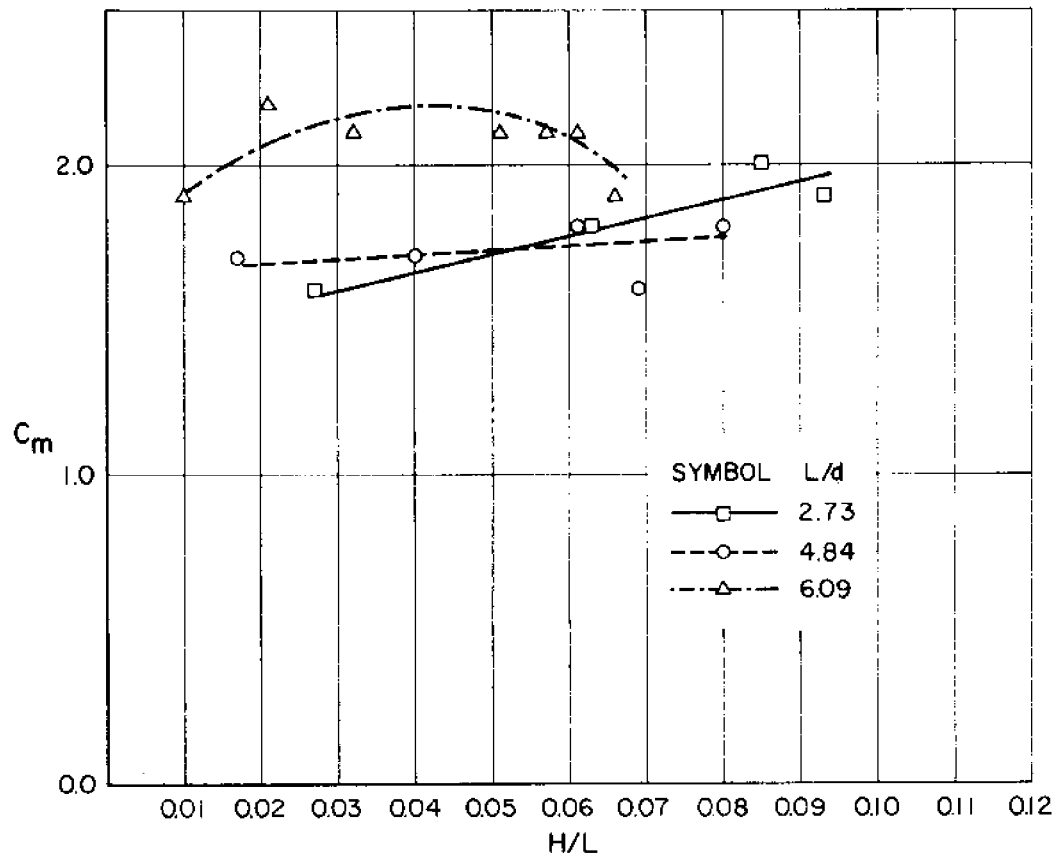

FIG. 38—COEFFICIENT OF INERTIA FOR HALF CYLINDER MODEL (SIDE FACING INCIDENT WAVE, WATER DEPTH 13 INCHES)

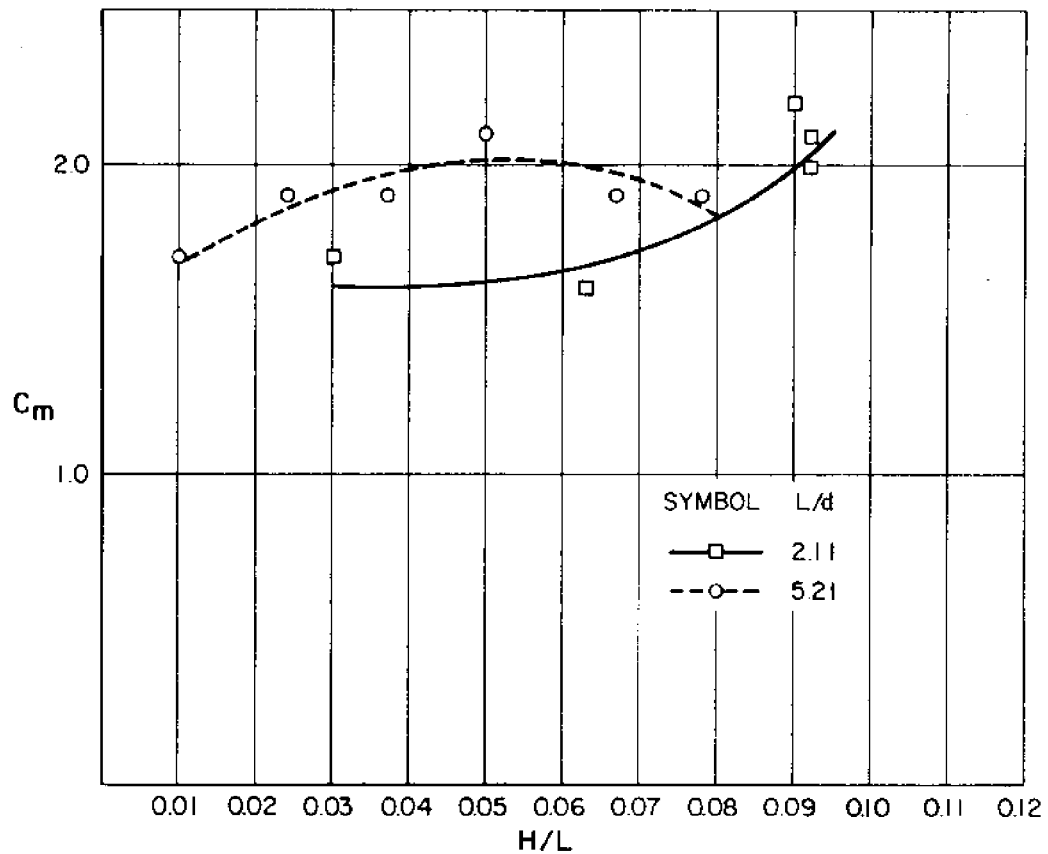

FIG. 39—COEFFICIENT OF INERTIA FOR HALF CYLINDER MODEL (SIDE FACING INCIDENT WAVE, WATER DEPTH 18 INCHES)

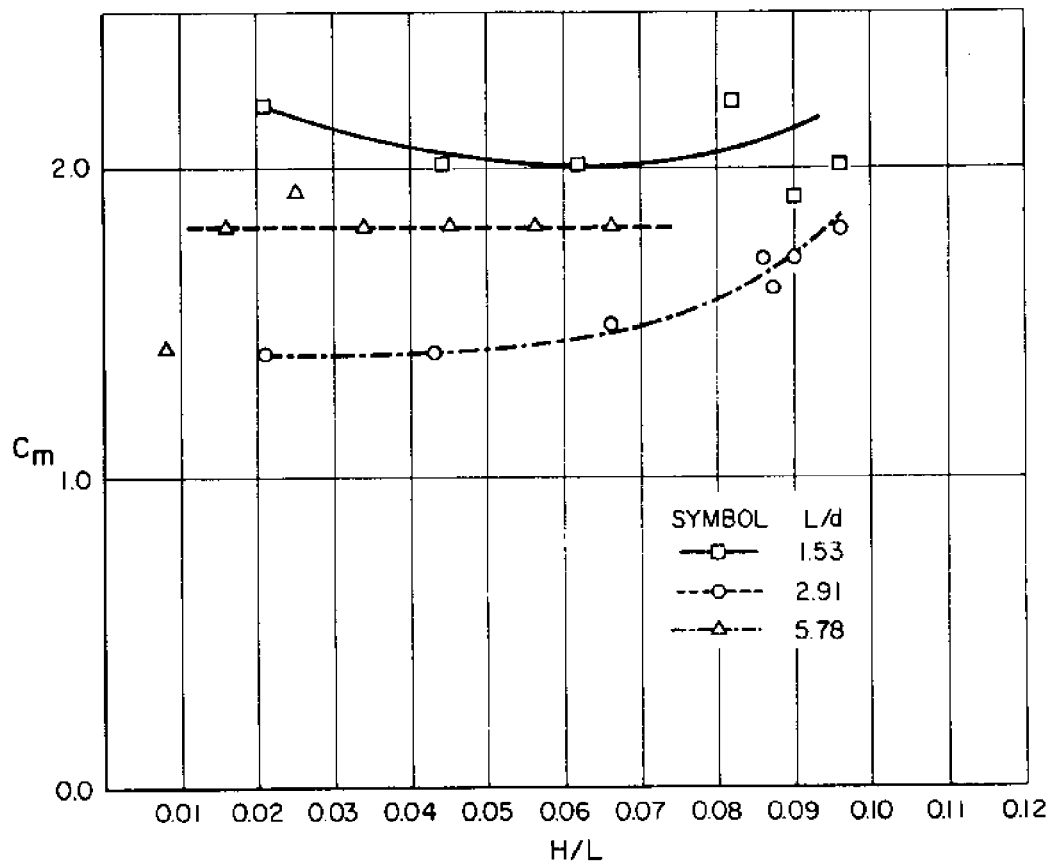

FIG. 40—COEFFICIENT OF INERTIA FOR HALF CYLINDER MODEL (SIDE FACING INCIDENT WAVE, WATER DEPTH 24 INCHES)

APPENDIX IV

COMPARISON OF MEASURED AND COMPUTED HORIZONTAL FORCES

COMPARISON OF MEASURED AND COMPUTED HORIZONTAL
FORCES FOR RECTANGULAR MODEL 8 INCHES LONG

d in feet	d/L	L/d	H/L	Measured Horizontal Force in grams	Computed Horizontal Force in grams		
					$C_m=1.5$	$C_m=1.8$	$C_m=2.0$
2.000	0.182	5.496	0.007	94	89	107	119
2.000	0.182	5.496	0.016	224	194	232	258
2.000	0.182	5.496	0.023	366	276	331	368
2.000	0.182	5.496	0.032	528	387	465	517
2.000	0.182	5.496	0.044	720	534	641	713
2.000	0.182	5.496	0.056	850	690	828	920
2.000	0.182	5.496	0.065	1000	791	949	1050
2.000	0.354	2.824	0.030	100	132	159	176
2.000	0.354	2.824	0.045	210	201	242	286
2.000	0.354	2.824	0.067	342	299	359	398
2.000	0.354	2.824	0.092	460	409	491	545
2.000	0.354	2.824	0.092	524	407	488	542
2.000	0.354	2.824	0.103	585	456	547	608
2.000	0.656	1.524	0.026	20	17	20	22
2.000	0.656	1.524	0.051	42	33	39	43
2.000	0.656	1.524	0.074	66	47	56	62
2.000	0.656	1.524	0.100	96	63	76	85
2.000	0.656	1.524	0.112	106	71	85	95
2.000	0.656	1.524	0.112	98	71	85	95
1.500	0.577	1.734	0.023	26	24	28	31
1.500	0.577	1.734	0.045	56	45	54	61
1.500	0.577	1.734	0.066	88	67	81	90
1.500	0.577	1.734	0.088	122	89	107	119
1.500	0.577	1.734	0.111	146	113	136	151
1.500	0.577	1.734	0.106	162	107	129	143

COMPARISON OF MEASURED AND COMPUTED HORIZONTAL
FORCES FOR RECTANGULAR MODEL 8 INCHES LONG
(Continued)

d in feet	d/L	L/d	H/L	Measured Horizontal Force in grams	Computed Horizontal Force in grams		
					$C_m = 1.5$	$C_m = 1.8$	$C_m = 2.0$
1.500	0.171	5.851	0.009	138	118	141	157
1.500	0.171	5.851	0.021	310	267	321	357
1.500	0.171	5.851	0.031	516	400	480	533
1.500	0.171	5.851	0.039	708	508	610	678
1.500	0.171	5.851	0.055	920	711	853	948
1.500	0.171	5.851	0.063	1080	811	973	1080
1.500	0.171	5.851	0.074	1200	949	1140	1270
1.083	0.167	6.002	0.012	160	153	183	204
1.083	0.167	6.002	0.012	170	153	183	204
1.083	0.167	6.002	0.012	192	155	186	206
1.083	0.167	6.002	0.025	408	322	386	429
1.083	0.167	6.002	0.038	644	499	598	665
1.083	0.167	6.002	0.051	952	668	801	890
1.083	0.167	6.002	0.069	1256	901	1080	1200
1.083	0.167	6.002	0.065	1152	849	1020	1130
1.083	0.223	4.483	0.022	234	213	256	284
1.083	0.223	4.483	0.044	568	426	511	568
1.083	0.223	4.483	0.066	920	629	755	839
1.083	0.223	4.483	0.091	1200	876	1050	1170
1.083	0.223	4.483	0.068	900	655	786	873
1.083	0.424	2.360	0.038	140	99	119	132
1.083	0.424	2.360	0.075	288	198	238	264
1.083	0.424	2.360	0.099	384	261	313	348
1.083	0.424	2.360	0.099	424	260	312	346
1.083	0.424	2.360	0.091	364	239	287	319
1.083	0.424	2.360	0.088	676	231	277	308

COMPARISON OF MEASURED AND COMPUTED HORIZONTAL
FORCES FOR RECTANGULAR MODEL 4 INCHES LONG

d in feet	d/L	L/d	H/L	Measured Horizontal Force in grams	Computed Horizontal Force in grams		
					$C_m=1.6$	$C_m=1.8$	$C_m=2.0$
2.000	0.173	5.770	0.031	320	323	363	404
2.000	0.173	5.770	0.038	431	389	437	486
2.000	0.173	5.770	0.045	520	468	526	584
2.000	0.173	5.770	0.045	230	236	266	295
2.000	0.173	5.770	0.014	160	149	168	186
2.000	0.345	2.898	0.037	180	141	158	176
2.000	0.345	2.898	0.055	280	210	237	263
2.000	0.345	2.898	0.074	374	283	318	354
2.000	0.345	2.898	0.075	373	287	323	359
2.000	0.345	2.898	0.068	315	259	292	324
1.500	0.200	4.992	0.013	110	120	135	150
1.500	0.200	4.992	0.032	245	287	323	359
1.500	0.200	4.992	0.042	375	372	419	465
1.500	0.200	4.992	0.059	554	527	593	658
1.500	0.200	4.992	0.067	716	601	676	751
1.500	0.200	4.992	0.082	800	733	824	916
1.500	0.479	2.086	0.033	64	54	60	67
1.500	0.479	2.086	0.066	132	107	121	134
1.500	0.479	2.086	0.096	200	155	174	194
1.500	0.479	2.086	0.100	210	162	182	202
1.500	0.479	2.086	0.094	200	152	171	190
1.500	0.479	2.086	0.087	179	141	159	176
1.083	0.378	2.642	0.032	112	97	109	121
1.083	0.378	2.642	0.067	230	201	226	252
1.083	0.378	2.642	0.070	230	210	236	262
1.083	0.378	2.642	0.098	320	294	330	367
1.083	0.378	2.642	0.098	330	294	330	367
1.083	0.378	2.642	0.091	300	273	307	341
1.083	0.378	2.642	0.089	310	268	302	336
1.083	0.378	2.642	0.085	304	255	287	318

COMPARISON OF MEASURED AND COMPUTED HORIZONTAL
FORCES FOR RECTANGULAR MODEL 4 INCHES LONG
(Continued)

d in feet	d/L	L/d	H/L	Measured Horizontal Force in grams	Computed Horizontal Force in grams		
					$C_m=1.6$	$C_m=1.8$	$C_m=2.0$
1.083	0.220	4.543	0.020	140	162	182	202
1.083	0.220	4.543	0.039	300	308	346	385
1.083	0.220	4.543	0.057	460	454	510	567
1.083	0.220	4.543	0.071	600	567	638	709
1.083	0.220	4.543	0.073	625	580	652	725
1.083	0.220	4.543	0.086	750	685	771	856
1.083	0.169	5.910	0.011	124	118	133	148
1.083	0.169	5.910	0.024	265	249	280	312
1.083	0.169	5.910	0.039	457	412	463	514
1.083	0.169	5.910	0.055	694	574	646	717
1.083	0.169	5.910	0.069	828	720	810	900
1.083	0.169	6.910	0.066	806	697	784	871

COMPARISON OF MEASURED AND COMPUTED HORIZONTAL
FORCES FOR RECTANGULAR MODEL 2 INCHES LONG

d in feet	d/L	L/d	H/L	Measured Horizontal Force in grams	Computed Horizontal Force in grams		
					$C_m=1.2$	$C_m=1.4$	$C_m=1.6$
2.000	0.180	5.547	0.006	56	49	57	65
2.000	0.180	5.547	0.014	116	108	126	144
2.000	0.180	5.547	0.015	118	112	131	150
2.000	0.180	5.547	0.025	196	184	214	245
2.000	0.180	5.547	0.035	296	262	306	350
2.000	0.180	5.547	0.043	392	320	374	427
2.000	0.180	5.547	0.060	506	447	522	596
2.000	0.180	5.547	0.061	624	460	536	613
2.000	0.344	2.909	0.021	58	61	71	81
2.000	0.344	2.909	0.043	121	125	146	167
2.000	0.344	2.909	0.068	183	197	230	263
2.000	0.344	2.909	0.089	244	259	302	345
2.000	0.344	2.909	0.094	296	273	318	364
2.000	0.344	2.909	0.094	266	272	317	362
2.000	0.646	1.547	0.024	5	10	12	14
2.000	0.646	1.547	0.049	23	21	24	28
2.000	0.646	1.547	0.071	35	30	35	40
2.000	0.646	1.547	0.094	48	40	47	54
2.000	0.646	1.547	0.110	52	47	54	62
2.000	0.646	1.547	0.109	58	46	54	62
1.500	0.467	2.140	0.032	43	42	50	57
1.500	0.467	2.140	0.062	94	82	95	109
1.500	0.467	2.140	0.083	132	109	127	145
1.500	0.467	2.140	0.099	142	130	152	173
1.500	0.467	2.140	0.088	110	116	135	154
1.500	0.201	4.975	0.013	78	84	98	113
1.500	0.201	4.975	0.027	182	178	207	237
1.500	0.201	4.975	0.040	290	270	315	360
1.500	0.201	4.975	0.054	462	364	425	486
1.500	0.201	4.975	0.061	568	411	480	548
1.500	0.201	4.975	0.078	640	524	612	699
1.500	0.201	4.975	0.069	524	460	536	613

COMPARISON OF MEASURED AND COMPUTED HORIZONTAL
FORCES FOR RECTANGULAR MODEL 2 INCHES LONG
(Continued)

d in feet	d/L	L/d	H/L	Measured Horizontal Force in grams	Computed Horizontal Force in grams		
					$C_m=1.2$	$C_m=1.4$	$C_m=1.6$
1.083	0.171	5.862	0.011	82	86	101	115
1.083	0.171	5.862	0.022	184	174	203	231
1.083	0.171	5.862	0.037	364	293	342	391
0.083	0.171	5.862	0.040	392	309	361	412
1.083	0.171	5.862	0.057	564	446	520	594
1.083	0.171	5.862	0.070	692	549	641	732
1.083	0.171	5.862	0.068	684	529	618	706
1.083	0.171	5.862	0.064	644	500	583	667
1.083	0.221	4.523	0.019	118	112	130	149
1.083	0.221	4.523	0.043	258	257	300	343
1.083	0.221	4.523	0.067	422	397	463	529
1.083	0.221	4.523	0.093	572	556	648	741
1.083	0.221	4.523	0.071	440	422	493	563
1.083	0.377	2.655	0.031	78	70	81	93
1.083	0.377	2.655	0.059	152	135	157	179
1.083	0.377	2.655	0.093	220	211	246	281
1.083	0.377	2.655	0.094	222	214	249	285
1.083	0.377	2.655	0.077	174	175	204	233

COMPARISON OF MEASURED AND COMPUTED HORIZONTAL
FORCES FOR HALF CYLINDER MODEL (END FACING INCIDENT WAVE)

d in feet	d/L	L/d	H/L	Measured Horizontal Force in grams	Computed Horizontal Force in grams		
					$C_m=1.6$	$C_m=1.8$	$C_m=2.0$
2.000	0.180	5.552	0.007	82	83	93	104
2.000	0.180	5.552	0.016	206	179	202	224
2.000	0.180	5.552	0.024	344	277	311	346
2.000	0.180	5.552	0.034	510	386	434	482
2.000	0.180	5.552	0.047	720	545	613	682
2.000	0.180	5.552	0.055	800	638	718	798
2.000	0.180	5.552	0.069	988	790	889	987
2.000	0.351	2.850	0.020	88	84	94	105
2.000	0.351	2.850	0.042	184	179	202	224
2.000	0.351	2.850	0.064	286	270	304	337
2.000	0.351	2.850	0.084	398	355	399	442
2.000	0.351	2.850	0.097	516	411	462	514
2.000	0.351	2.850	0.091	448	383	431	478
2.000	0.653	1.532	0.021	20	13	14	16
2.000	0.653	1.532	0.047	36	29	32	36
2.000	0.653	1.532	0.070	56	43	48	54
2.000	0.653	1.532	0.093	76	57	64	71
2.000	0.653	1.532	0.180	86	66	74	82
2.000	0.653	1.532	0.100	86	61	68	76
1.500	0.474	2.108	0.033	72	62	69	77
1.500	0.474	2.108	0.067	141	125	141	156
1.500	0.474	2.108	0.092	212	173	194	216
1.500	0.474	2.108	0.098	220	183	206	229
1.500	0.474	2.108	0.087	162	162	183	203
1.500	0.200	5.006	0.011	127	113	127	141
1.500	0.200	5.006	0.025	288	254	286	318
1.500	0.200	5.006	0.040	480	416	468	520
1.500	0.200	5.006	0.055	724	566	637	708
1.500	0.200	5.006	0.070	984	717	807	897
1.500	0.200	5.006	0.080	1072	827	931	1030
1.500	0.200	5.006	0.068	864	698	785	873

COMPARISON OF MEASURED AND COMPUTED HORIZONTAL
FORCES FOR HALF CYLINDER MODEL (END FACING INCIDENT WAVE)
(Continued)

d in feet	d/L	L/d	H/L	Measured Horizontal Force in grams	Computed Horizontal Force in grams		
					$C_m=1.6$	$C_m=1.8$	$C_m=2.0$
1.083	0.169	5.926	0.012	128	150	169	188
1.083	0.169	5.926	0.024	320	285	321	357
1.083	0.169	5.926	0.038	560	464	522	580
1.083	0.169	5.926	0.059	904	714	803	892
1.083	0.169	5.926	0.069	1152	826	930	1030
1.083	0.169	5.926	0.062	1096	751	845	939
1.083	0.222	4.512	0.018	172	162	183	203
1.083	0.222	4.512	0.041	406	369	415	461
1.083	0.222	4.512	0.064	684	581	653	726
1.083	0.222	4.512	0.088	952	797	896	996
1.083	0.222	4.512	0.067	720	601	676	751
1.083	0.382	2.619	0.032	104	104	117	130
1.083	0.382	2.619	0.065	220	212	239	266
1.083	0.382	2.619	0.096	336	314	353	393
1.083	0.382	2.619	0.091	300	297	334	371
1.083	0.382	2.619	0.086	288	282	317	352

COMPARISON OF MEASURED AND COMPUTED HORIZONTAL
FORCES FOR HALF CYLINDER MODEL (SIDE FACING INCIDENT WAVE)

d in feet	d/L	L/d	H/L	Measured Horizontal Force in grams	Computed Horizontal Force in grams		
					$C_m=1.6$	$C_m=1.8$	$C_m=2.0$
2.000	0.179	5.578	0.008	80	89	100	111
2.000	0.179	5.578	0.016	204	179	202	224
2.000	0.179	5.578	0.025	340	284	320	356
2.000	0.179	5.578	0.034	460	390	438	487
2.000	0.179	5.578	0.045	600	515	580	644
2.000	0.179	5.578	0.056	728	643	723	804
2.000	0.179	5.578	0.066	892	754	849	943
2.000	0.344	2.907	0.021	78	91	102	113
2.000	0.344	2.907	0.043	170	189	212	236
2.000	0.344	2.907	0.065	272	286	322	358
2.000	0.344	2.907	0.087	380	382	430	477
2.000	0.344	2.907	0.086	400	377	425	472
2.000	0.344	2.907	0.096	484	423	475	528
2.000	0.344	2.907	0.095	448	417	469	521
2.000	0.653	1.532	0.021	18	13	14	16
2.000	0.653	1.532	0.021	34	27	30	34
2.000	0.653	1.532	0.021	49	38	43	47
2.000	0.653	1.532	0.021	69	50	56	62
2.000	0.653	1.532	0.021	74	58	65	72
2.000	0.653	1.532	0.021	68	55	62	69
1.500	0.473	2.113	0.030	61	57	64	71
1.500	0.473	2.113	0.030	123	118	133	148
1.500	0.473	2.113	0.030	224	173	195	217
1.500	0.473	2.113	0.030	238	169	190	212
1.500	0.473	2.113	0.030	234	173	195	217
1.500	0.473	2.113	0.030	170	168	189	210
1.500	0.192	5.206	0.010	121	110	123	137
1.500	0.192	5.206	0.024	318	255	287	319
1.500	0.192	5.206	0.037	492	400	450	500
1.500	0.192	5.206	0.050	720	537	604	671
1.500	0.192	5.206	0.067	900	721	811	901
1.500	0.192	5.206	0.078	1000	830	934	1004

COMPARISON OF MEASURED AND COMPUTED HORIZONTAL
FORCES FOR HALF CYLINDER MODEL (SIDE FACING INCIDENT WAVE)
(Continued)

d in feet	d/L	L/d	H/L	Measured Horizontal Force in grams	Computed Horizontal Force in grams		
					$C_m = 1.6$	$C_m = 1.8$	$C_m = 2.0$
1.083	0.164	6.088	0.010	151	123	138	153
1.083	0.164	6.088	0.021	370	259	291	323
1.083	0.164	6.088	0.037	604	450	506	563
1.083	0.164	6.088	0.051	860	623	701	779
1.083	0.164	6.088	0.066	964	811	912	1010
1.083	0.164	6.088	0.061	1008	748	841	935
1.083	0.164	6.088	0.057	944	703	791	879
1.083	0.207	4.836	0.017	174	164	184	205
1.083	0.207	4.836	0.040	428	393	442	491
1.083	0.207	4.836	0.061	672	600	675	750
1.083	0.207	4.836	0.080	916	779	876	973
1.083	0.207	4.836	0.069	700	671	754	838
1.083	0.367	2.725	0.027	100	97	110	122
1.083	0.367	2.725	0.063	260	226	255	283
1.083	0.367	2.725	0.093	406	333	375	417
1.083	0.367	2.725	0.085	402	307	345	383

APPENDIX V

SAMPLE COMPUTATION OF HORIZONTAL FORCE

The following is a sample computation for a submerged tank utilizing the dimensionless force plots presented in Appendix II. A check on the answer obtained by the use of these curves is made by computing the force utilizing the method set forth by Reid and Bretschneider (15).

Given:

Wave: Period = $T = 10$ seconds
 Height = $H = 10$ feet
 Water depth = $d = 150$ feet

Model: Height = $H_m = 40$ feet
 Width = $W_m = 60$ feet
 Length = $L_m = 70$ feet

$$L_o = 5.12 T^2 \dots \dots \dots (23)$$

$$= 512 \text{ feet}$$

$$d/L_o = 150/512 = 0.293$$

$$d/L = 0.3058 \quad \text{[from Appendix I of Wiegel (16)]}$$

$$L = 491$$

$$L/d = 3.27$$

$$H/L = 10/491 = 0.02$$

$$F_{DIM} = 14.3 \quad \text{[from Appendix II, Fig. 20]}$$

$$F_{DIM} = \frac{F_{max}}{\gamma \frac{A^3}{d} \frac{H}{2}}$$

$$14.3 = \frac{F_{max}}{\gamma \frac{A^3}{d} \frac{H}{2}}$$

$$A = \frac{H_m^2}{L_m} = \frac{(40)(40)}{70} = 22.8$$

$$A^3 = 11,850$$

$$\begin{aligned} F_{max} &= \frac{(F_{DIM})(A^3)(\gamma)(H)}{(2)(d)} \\ &= \frac{(14.3)(11,850)(62.4)(10)}{(2)(150)} \\ &= \underline{352,000 \text{ LB}} \end{aligned}$$

Check:

An inertial coefficient of 1.8 will be used in Eq. 40.

$$(F_H)_{max} = C_m H_m W_m K \gamma H \sin\left(\frac{\pi L_m}{L}\right) \dots \dots \dots (40)$$

$$K = 0.30 \quad (\text{from Fig. 41 or from Eq. 37})$$

$$\begin{aligned} (F_H)_{max} &= (1.8)(40)(60)(0.30)(62.4)(10)\left(\sin\left(\frac{\pi(70)}{491}\right)\right) \\ &= (1.8)(40)(60)(0.30)(62.4)(10)(\sin(0.448)) \\ &= \underline{347,000 \text{ LBS}} \end{aligned}$$

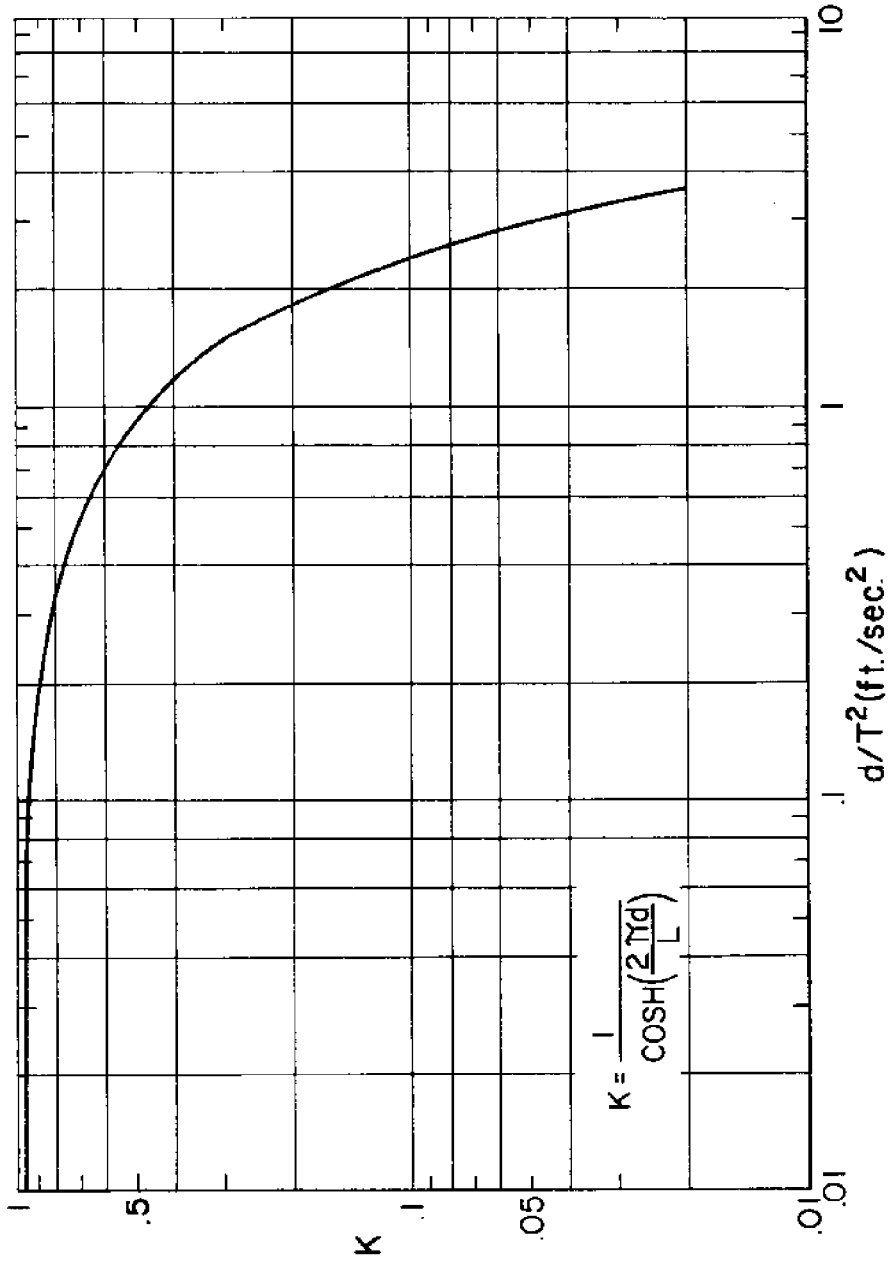

FIG. 41— PRESSURE FACTOR [AFTER REID AND BRETSCHNEIDER (15)]

```

C      HORZW = DIMENSIONLESS HORIZONTAL FORCE IN DIRECTION OF WAVES
C      HORZO = DIMENSIONLESS HORIZONTAL FORCE IN OPPOSITE DIRECTION FROM WAVES
C      VERTD = DIMENSIONLESS VERTICAL FORCE DOWN
C      VERTU = DIMENSIONLESS VERTICAL FORCE UP
C      GAMMA = UNIT WEIGHT OF WATER
C      HM = HEIGHT OF MODEL (IN FEET)
C      WM = WIDTH OF MODEL (IN FEET)
C      LM = LENGTH OF MODEL (IN FEET)
C      RK = K ON FIGURE 16 IN REID'S PAPER
C      CM = INERTIAL COEFFICIENT
C      HFT = TOTAL COMPUTED HORIZONTAL FORCE
C      FORHZW = HORZFW
C
COMMON T(15),O(15),HT(15),PER,DEP,LENG,LO,H,KRUNNO(15),HORZFW(15)
1, HORZFO(15), VERTFD(15), VERTFU(15), GAMMA, HM, WM, LM, HORZW,
2 HORZO, VERTD, VERTU, RK, CM, HFT, FORHZW
REAL LENG,LO, LM
WRITE (6,200)
200 FORMAT (1H1,'RUN DEPTH PERIOD TAVG HEIGHT D/L L/D H/L
1VERTFD VERTFU HORZFW HORZFO VERTD VERTU HORZW HORZO CM
2 HFT',/)
LINES = 2
READ(5,102) HM,WM,LM
102 FORMAT(F5.3, 2X, F5.3, 2X, F5.3)
GAMMA = 62.4
4 READ(5,100)N
100 FORMAT (I2)
IF (N.LE. 0.0) STOP
DO 1 I = 1, N
READ (5,101)KRUNNO(I), T(I), D(I), HT(I), VERTFD(I), VERTFU(I),
1 HORZFW(I), HORZFO(I)
101 FORMAT (I4, 2X, F5.3, 2X, F5.3, 2X, F5.3, 2X, F3.0, 2X,
10
11
12
20
30
40
50
51
60
61
62
63
70
80
90
100
110
111
120

```

```

121 1 F4.0, 2X, F4.0)
130 1 CONTINUE
140 TSUM = 0.
150 DO 2 J = 1,N
160 TSUM = TSUM + T(J)
170 2 CONTINUE
180 TAVG = TSUM/N
190 PER = TAVG
200 DO 3 K = 1, N
210 DEP = D(K)
220 H = HT(K)
221 FORHZW = HORZFW(K)
230 CALL PROF1
231 CALL FORCE2

231 HORZW = HORZFW(K)*2.0*0.002205*DEP*(LM**3)/(GAMMA**H*(HM**6))
232 HORZO = HORZFD(K)*2.0*0.002205*DEP*(LM**3)/(GAMMA**H*(HM**6))
233 VERTD = VERTFD(K)*2.0*0.002205*DEP*(LM**3)/(GAMMA**H*(HM**6))
234 VERTU = VERTFU(K)*2.0*0.002205*DEP*(LM**3)/(GAMMA**H*(HM**6))
240 DL = DEP/LENG
250 SLD = LENG/DEP
260 HL = H/LENG
270 IF (LINES .LT. 50) GO TO 10
280 11 WRITE (6,200)
290 LINES = 2
300 GO TO 9
310 10 WRITE (6,201)KRUNN(K), D(K), T(K), PER, H, DL, SLD, HL, VERTFD(K)
311 1 , VERTFU(K), HORZFW(K), HORZFO(K), VERTD, VERTU, HORZW, HORZO,
312 2 CM, HFT
320 201 FORMAT (1X, I4, 2X, F5.3, 2X, F5.3, 2X, F5.3, 2X, F5.3, 2X, F5.3,
330 1 2X, F5.3, 2X, F5.3, 2X, F4.0, 2X, F4.0, 2X, F5.0, 2X, F5.0, 2X,
331 2 F5.2, 2X, F5.2, 2X, F5.2, 2X, F5.2, 2X, F5.2, 2X, 1PE10.2)
340 LINES = LINES + 1

```

C

```
IF (LINES .EQ. 50) GO TO 11
  9 CONTINUE
  3 CONTINUE
    WRITE (6,202)
    202 FORMAT (1X,/)
    LINES = LINES + 1
    IF (LINES .EQ. 50) GO TO 30
    GO TO 4
  30 WRITE (6, 200)
    LINES = 2
    GO TO 4
  END
```

```
350
360
370
380
390
400
410
420
430
440
450
460
```



```

470 SUBROUTINE PROF1
480 COMMON T(15),D(15),HT(15),HT(15),PER,DEP,LENG,LO,H,KRUNNO(15), HORZFW(15)
481 1, HORZFO(15), VERTFD(15), VERTFU(15), GAMMA, HM, WM, LM, HORZW,
482 2 HORZO, VERTD, VERTU, RK, CM, HFT, FORHZW
490 REAL LO, LENG,LNDW,LENGO, LM
500 LO=5.12*PER**2
510 DLO=DEP/LO
520 IF (DLO-.04) 10,1,1
530 1 IF (DLO-.15) 20,2,2
540 2 IF (DLO-.39) 30,40,40
550 10 DL=0.43*DLO**.511
560 GO TO 100
570 20 DL=0.54*DLO**.58
580 GO TO 100
590 30 DL=0.83*DLO**.808
600 GO TO 100
610 40 DL=DLO
620 100 LNDW=DEP/DL
630 PID=6.2832*DEP
640 LENG=LO*TANH(PID/LNDW)
650 GO 300 K=1,500
660 LENGO=LENG
670 LENG=LO*TANH(PID/LENGO)
680 IF (.005*LENGO .GE. ABS(LENGO-LENG)) GO TO 400
690 300 CONTINUE
700 400 CONTINUE
710 RETURN
720 END

```

```
730 FUNCTION SINH(X)
740 SINH=(EXP(X)-(1./EXP(X)))/2.
750 RETURN
760 END
```

```
770 FUNCTION COSH(X)
780 COSH=(EXP(X)+(1./EXP(X)))/2.
790 RETURN
800 END
```

```
820 SUBROUTINE FORCE1
830 THIS SUBROUTINE FOR REID'S SOLUTION CONSTANT X-SECTION MODELS ONLY
840 COMMON T(15),O(15),HT(15),PER,DEP,LENG,LO,H,KRUNND(15), HORZFW(15)
850 1, HORZFD(15), VERTFD(15), VERTFU(15), GAMMA, HM, WM, LM, HORZW,
860 2 HORZO, VERTD, VERTU, RK, CM, HFT, FORHZW
870 REAL LENG,LO, LM
880 CM = 1.8
890 RK = 1.0/(COSH((2.0*3.1416*DEP)/LENG))
900 HFT = CM*HM*WM*RK*GAMMA**453.515 *H *SIN((3.1416*LM)/LENG)
910 RETURN
END
```

```

C
SUBROUTINE FORCE2
THIS SUBROUTINE FOR REID'S SOLUTION CONSTANT X-SECTION MODELS ONLY
COMMON T(15),D(15),HT(15),PER,DEP,LENG,LO,H,KRUNNO(15),HORZFW(15)
1, HORZFO(15), VERTFD(15), VERTFU(15), GAMMA, HM, WM, LM, HORZWM,
2 HORZO, VERTD, VERTU, RK, CM, HFT, FORHZW
REAL LENG,LO, LM
CM = 0.0
17 CM = CM + 0.1
NCCOUNT = 0
NCCOUNT = NCCOUNT + 1
RK = 1.0/(COSH(12.0*3.1416*DEP)/LENG))
HFT = CM*HM*WM*RK*GAMMA*453.515 *H *SIN((3.1416*LM)/LENG)
IF(0.05*FORHZW .GE. ABS(FORHZW - HFT)) GO TO 16
IF (NCCOUNT .GT. 100) GO TO 16
GO TO 17
16 CONTINUE
RETURN
END

```

```

920
930
940
950
960
970
980
990
1000
1010
1020
1030
1040
1050
1060
1070
1080

```

RUN	DEPTH	PERIOD	TAVG	HEIGHT	D/L	L/D	H/L	VERTD	VFRTU	HORIZW	HERZO	CM	MFT
3990	2.000	1.642	1.634	0.080	0.190	5.552	0.007	32.	5.62	5.44	14.40	16.68	9.33E 01
4000	2.000	1.681	1.634	0.173	0.190	5.552	0.015	82.	6.17	5.12	16.73	15.75	2.02E 02
4010	2.000	1.690	1.634	0.267	0.190	5.552	0.036	174.	7.14	6.05	18.10	16.84	3.11E 02
4020	2.000	1.674	1.634	0.372	0.180	5.552	0.034	344.	7.70	5.14	19.26	17.52	4.34E 02
4030	2.000	1.593	1.634	0.526	0.180	5.552	0.047	510.	8.84	5.93	19.23	18.16	6.13E 02
4042	2.000	1.575	1.634	0.616	0.180	5.552	0.055	680.	7.72	6.11	18.24	18.43	7.18E 02
4050	2.000	1.550	1.634	0.762	0.180	5.552	0.069	958.	6.49	5.49	18.21	16.74	8.89E 02
4060	2.000	1.550	1.500	0.092	0.203	4.929	0.009	91.	5.80	5.50	14.64	13.89	1.07E 02
4070	2.000	1.547	1.500	0.198	0.203	4.929	0.020	205.	7.75	5.96	15.39	14.19	2.30E 02
4080	2.000	1.542	1.500	0.323	0.203	4.929	0.033	378.	7.05	6.09	16.76	15.44	3.76E 02
4090	2.000	1.490	1.500	0.382	0.203	4.929	0.039	528.	8.09	6.80	21.03	19.42	4.45E 02
4100	2.000	1.475	1.500	0.492	0.203	4.929	0.050	740.	7.92	6.97	21.13	19.30	5.73E 02
4110	2.000	1.458	1.500	0.600	0.203	4.929	0.061	936.	8.66	8.71	21.91	20.04	6.98E 02
4120	2.000	1.435	1.500	0.720	0.203	4.929	0.073	1040.	8.68	7.39	20.29	18.11	8.38E 02
4130	2.000	1.285	1.254	0.095	0.267	3.750	0.013	78.	5.27	6.00	12.29	11.61	1.02E 02
4140	2.000	1.280	1.254	0.188	0.267	3.750	0.025	183.	6.87	7.17	13.67	13.30	2.00E 02
4150	2.000	1.260	1.254	0.306	0.267	3.750	0.041	328.	6.52	6.34	14.67	14.69	3.25E 02
4160	2.000	1.250	1.254	0.420	0.267	3.750	0.056	470.	6.45	6.54	15.72	15.18	4.46E 02
4170	2.000	1.242	1.254	0.520	0.267	3.750	0.069	608.	7.05	7.21	16.32	16.21	5.52E 02
4180	2.000	1.235	1.254	0.600	0.267	3.750	0.080	772.	7.70	7.42	18.07	17.42	6.37E 02
4190	2.000	1.225	1.254	0.684	0.267	3.750	0.091	956.	7.35	6.92	17.50	17.09	7.26E 02
4200	2.000	1.085	1.068	0.113	0.351	2.850	0.020	51.	6.46	6.34	10.94	10.19	9.43E 01
4210	2.000	1.075	1.068	0.242	0.351	2.850	0.042	117.	6.50	6.79	10.68	10.10	2.02E 02
4220	2.000	1.073	1.068	0.364	0.351	2.850	0.064	181.	6.87	6.99	11.04	11.42	3.64E 02
4230	2.000	1.065	1.068	0.478	0.351	2.850	0.084	232.	6.82	6.79	11.70	11.70	3.99E 02
4240	2.000	1.055	1.068	0.554	0.351	2.850	0.097	270.	7.20	6.85	13.08	12.27	1.80
4250	2.000	1.035	1.068	0.615	0.351	2.850	0.091	336.	7.13	6.42	12.20	11.65	4.31E 02
4260	2.000	0.890	0.882	0.096	0.504	1.984	0.024	48.	6.15	5.27	7.02	5.85	4.34E 01
4270	2.000	0.885	0.882	0.215	0.504	1.984	0.054	98.	4.94	4.55	6.37	6.05	9.78E 01
4280	2.000	0.865	0.882	0.322	0.504	1.984	0.081	152.	4.89	4.82	6.63	6.15	1.46E 02
4290	2.000	0.885	0.882	0.416	0.504	1.984	0.105	198.	5.03	4.36	6.69	6.42	1.88E 02
4300	2.000	0.865	0.882	0.378	0.504	1.984	0.095	158.	4.53	4.13	5.13	7.36	1.71E 02
4310	2.000	0.775	0.774	0.064	0.653	1.532	0.021	16.	3.51	3.51	4.39	3.51	1.43E 01
4320	2.000	0.778	0.774	0.144	0.653	1.532	0.047	31.	3.02	3.02	3.51	3.12	3.23E 01
4330	2.000	0.775	0.774	0.216	0.653	1.532	0.070	50.	3.25	2.80	3.64	3.12	1.80
4340	2.000	0.775	0.774	0.284	0.653	1.532	0.093	69.	3.41	3.02	3.76	3.35	1.80
4350	2.000	0.770	0.774	0.330	0.653	1.532	0.108	76.	3.24	3.06	3.66	3.49	1.80
4360	2.000	0.770	0.774	0.305	0.653	1.532	0.100	75.	3.45	3.22	3.96	3.55	1.80
4370	1.500	0.712	0.712	0.050	0.579	1.726	0.019	24.	5.06	5.06	5.06	4.85	1.80
4380	1.500	0.711	0.712	0.102	0.579	1.726	0.039	55.	5.68	5.78	4.96	4.54	4.16E 01
4390	1.500	0.711	0.712	0.158	0.579	1.726	0.061	80.	5.33	5.07	5.27	4.73	1.80
4400	1.500	0.711	0.712	0.218	0.579	1.726	0.084	104.	5.03	5.36	5.07	4.74	1.80

COMPUTER OUTPUT FROM PROGRAM FOR WAVE PARAMETERS AND INERTIAL WAVE FORCES FOR MODELS OF REGULAR CROSS SECTION (SUBPROGRAM FORCE-1)

RUN	DEPTH	PERIOD	YAVG	HEIGHT	D/L	L/D	H/L	VERTFU	HORZFW	HORZFV	VERTD	VERTU	HORZM	HORZO	CM	HFT
3990	2.000	1.682	1.634	0.080	0.180	5.552	0.007	32.	82.	95.	5.62	5.44	16.40	16.68	1.60	8.29E 01
4000	2.000	1.681	1.634	0.173	0.180	5.552	0.016	76.	206.	194.	6.17	6.12	16.73	15.75	1.80	2.02E 02
4010	2.000	1.680	1.634	0.267	0.180	5.552	0.024	136.	344.	320.	7.16	6.05	18.10	16.84	1.90	3.29E 02
4020	2.000	1.674	1.634	0.372	0.180	5.552	0.034	204.	510.	468.	7.70	5.14	19.26	17.52	2.10	5.06E 02
4030	2.000	1.593	1.634	0.526	0.180	5.552	0.047	276.	720.	680.	8.84	2.93	19.23	18.16	2.10	7.16E 02
4042	2.000	1.575	1.634	0.916	0.180	5.552	0.055	308.	800.	808.	7.02	6.11	19.24	18.43	2.00	7.98E 02
4050	2.000	1.550	1.634	0.782	0.180	5.552	0.069	352.	988.	908.	6.49	5.49	18.21	16.74	2.00	9.67E 02
4060	2.000	1.550	1.500	0.092	0.203	4.929	0.009	38.	96.	91.	5.80	5.50	14.66	13.89	1.60	9.52E 01
4070	2.000	1.547	1.500	0.198	0.203	4.929	0.020	81.	224.	200.	5.75	5.96	15.89	14.19	1.70	2.18E 02
4080	2.000	1.542	1.500	0.323	0.203	4.929	0.033	162.	390.	378.	7.05	6.09	16.96	16.44	1.80	3.76E 02
4090	2.000	1.490	1.500	0.362	0.203	4.929	0.039	220.	572.	578.	8.09	6.80	21.03	19.42	2.20	5.43E 02
4100	2.000	1.475	1.500	0.492	0.203	4.929	0.050	274.	740.	740.	7.82	6.97	21.13	19.30	2.30	7.32E 02
4110	2.000	1.458	1.500	0.600	0.203	4.929	0.061	370.	936.	856.	8.66	8.71	21.91	20.04	2.30	8.92E 02
4120	2.000	1.435	1.500	0.720	0.203	4.929	0.073	445.	1040.	928.	6.88	7.39	20.29	18.11	2.20	1.02E 03
4130	2.000	1.285	1.254	0.056	0.267	3.750	0.013	36.	84.	78.	5.27	6.00	12.29	11.41	1.50	8.50E 01
4140	2.000	1.280	1.254	0.188	0.267	3.750	0.025	92.	183.	178.	6.87	7.17	13.67	13.30	1.60	1.77E 02
4150	2.000	1.260	1.254	0.316	0.267	3.750	0.041	142.	324.	320.	6.52	6.14	14.87	14.69	1.80	3.23E 02
4160	2.000	1.250	1.254	0.420	0.267	3.750	0.056	193.	470.	454.	6.46	6.59	15.72	15.18	1.90	4.71E 02
4170	2.000	1.242	1.254	0.520	0.267	3.750	0.069	261.	604.	600.	7.05	7.21	16.37	16.21	1.90	5.83E 02
4180	2.000	1.235	1.254	0.600	0.267	3.750	0.080	317.	744.	744.	7.70	7.42	18.07	17.42	2.10	7.43E 02
4190	2.000	1.225	1.254	0.684	0.267	3.750	0.091	358.	856.	832.	7.35	6.92	17.58	17.09	2.10	8.47E 02
4200	2.000	1.095	1.068	0.113	0.351	2.850	0.020	52.	88.	82.	6.46	6.34	10.94	10.19	1.60	8.38E 01
4210	2.000	1.075	1.068	0.242	0.351	2.850	0.042	112.	184.	174.	6.50	6.79	10.68	10.10	1.60	1.78E 02
4220	2.000	1.073	1.068	0.364	0.351	2.850	0.064	178.	286.	296.	6.87	6.99	11.04	11.42	1.70	2.87E 02
4230	2.000	1.065	1.068	0.478	0.351	2.850	0.084	232.	398.	398.	6.82	5.79	11.70	11.70	1.80	3.99E 02
4240	2.000	1.055	1.068	0.554	0.351	2.850	0.097	284.	516.	484.	7.20	5.85	13.08	12.27	2.00	5.14E 02
4250	2.000	1.055	1.068	0.516	0.351	2.850	0.091	262.	448.	428.	7.13	6.42	12.20	11.65	1.80	4.31E 02
4260	2.000	0.890	0.882	0.096	0.504	1.984	0.024	42.	48.	40.	6.15	5.27	7.02	5.85	1.90	4.59E 01
4270	2.000	0.885	0.882	0.216	0.504	1.984	0.054	76.	98.	93.	4.94	4.55	6.37	6.05	1.80	9.78E 01
4280	2.000	0.885	0.882	0.322	0.504	1.984	0.081	112.	152.	141.	4.89	4.62	6.63	6.15	1.80	1.46E 02
4290	2.000	0.885	0.882	0.416	0.504	1.984	0.105	149.	198.	190.	5.03	4.36	6.69	6.42	1.80	1.88E 02
4300	2.000	0.865	0.882	0.378	0.504	1.984	0.095	122.	165.	198.	4.53	4.13	6.13	7.36	1.70	1.62E 02
4310	2.000	0.775	0.774	0.064	0.653	1.532	0.021	16.	20.	16.	3.51	3.51	4.39	3.51	2.40	1.91E 01
4320	2.000	0.778	0.774	0.144	0.653	1.532	0.047	31.	36.	32.	3.02	3.02	3.51	3.12	2.00	3.58E 01
4330	2.000	0.775	0.774	0.216	0.653	1.532	0.070	50.	56.	48.	3.25	2.80	3.54	3.12	2.00	5.37E 01
4340	2.000	0.775	0.774	0.284	0.653	1.532	0.093	69.	76.	68.	3.41	3.52	3.76	3.36	2.10	7.42E 01
4350	2.000	0.770	0.774	0.330	0.653	1.532	0.108	76.	86.	82.	3.24	3.56	3.66	3.49	2.00	8.21E 01
4360	2.000	0.770	0.774	0.305	0.653	1.532	0.100	75.	86.	77.	3.45	3.22	3.96	3.55	2.20	8.34E 01
4370	1.500	0.712	0.712	0.050	0.579	1.726	0.019	24.	24.	23.	5.06	5.90	5.06	4.85	2.10	2.38E 01
4380	1.500	0.711	0.712	0.102	0.579	1.726	0.039	55.	48.	44.	5.68	5.78	4.96	4.54	2.00	4.62E 01
4390	1.500	0.711	0.712	0.158	0.579	1.726	0.061	80.	76.	71.	5.33	5.07	5.27	4.73	2.10	7.51E 01
4400	1.500	0.711	0.712	0.218	0.579	1.726	0.084	104.	111.	98.	5.03	5.36	5.07	4.74	2.10	1.04E 02

COMPUTER OUTPUT FROM PROGRAM FOR WAVE PARAMETERS AND INERTIAL WAVE FORCES FOR MODELS OF REGULAR CROSS SECTION (SUBPROGRAM FORCE-2)

```

4 READ(5,100)N
100 FORMAT (I2)
IF (N.LE. 0.0) STOP
DO 1 I = 1, N
  READ (5,101)KRUNNO(I), T(I), D(I), HT(I), VERTFD(I), VERTFU(I),
1 HORZFW(I), HORZFO(I)
101 FORMAT (I4, 2X, F5.3, 2X, F5.3, 2X, F5.3, 2X, F3.0, 2X, F3.0, 2X,
1 F4.0, 2X, F4.0)
1 CONTINUE
  TSUM = 0.
DO 2 J = 1, N
  TSUM = TSUM + T(J)
2 CONTINUE
  TAVG = TSUM/N
  PER = TAVG
DO 3 K = 1, N
20 DEP = D(K)
  H = HT(K)
  FORHZW = HORZFW(K)
  CALL PROF1
  CALL FORCE3

```

C
C
C
C

THE NEXT FOUR CARDS ARE FOR ALL MODELS EXCEPT FLAT PLATE
THEY CONVERT FORCE IN GRAMS TO DIMENSIONLESS FORCE.

```

HORZW = HORZFW(K)*2.0*0.002205*DEP*(LM**3)/(GAMMA*H*(HM**6))
HORZO = HORZFO(K)*2.0*0.002205*DEP*(LM**3)/(GAMMA*H*(HM**6))
VERTD = VERTFD(K)*2.0*0.002205*DEP*(LM**3)/(GAMMA*H*(HM**6))
VERTU = VERTFU(K)*2.0*0.002205*DEP*(LM**3)/(GAMMA*H*(HM**6))
DL = DEP/LENG
SLD = LENG/DEP
HL = H/LENG
IF (LINES .LT. 50) GO TO 10

```

70
80
90
100
110
111
120
121
130
140
150
160
170
180
190
200
210
220
221
230
231

231
232
233
234
240
250
260
270

```

280 11 WRITE (6,200)
290   LINES = 2
300   GO TO 9
310 10 WRITE (6,201) KRUNND(K), D(K), T(K), PER, H, DL, SLD, HL, VERTFD(K)
311   1 , VERTFU(K), HDRZFW(K), HDRZFO(K), VERTD, VERTU, HORZM, HORZO,
312   2 CM, HSUM
320 201 FORMAT (IX, I4, 2X, F5.3, 2X, F5.3, 2X, F5.3, 2X, F5.3, 2X, F5.3,
330   1 2X, F5.3, 2X, F5.3, 2X, F4.0, 2X, F4.0, 2X, F5.0, 2X, F5.0, 2X,
331   2 F5.2, 2X, F5.2, 2X, F5.2, 2X, F5.2, 2X, F5.2, 2X, 1PE10.2)
340   LINES = LINES + 1
350   IF (LINES .EQ. 50) GO TO 11
360   9 CONTINUE
370   3 CONTINUE
380   WRITE (6,202)
390   202 FORMAT (IX,/)
400   LINES = LINES + 1
410   IF (LINES .EQ. 50) GO TO 30
420   GO TO 4
430   30 WRITE (6, 200)
440   LINES = 2
450   GO TO 4
460   END

```

```

SUBROUTINE PROF1
COMMON T(15),D(15),HT(15),PER,DEP,LENG,LO,H,KRUNNC(15), HORZFW(15)
1, HORZFO(15), VERTFD(15), VERTFU(15), GAMMA, HM, WM, LM, HORZW,
2 HORZO, VERTD, VERTU, RK, CM, HFT, FORHZW, HQ(15), WQ(15), LQ(15),
3 HSUM
REAL LENG,LO, LM, LQ
LO=5.12*PER**2
DLO=DEP/LO
IF (DLO-.04) 10,1,1
1 IF(DLO-.15) 20,2,2
2 IF (DLO-.39) 30,40,40
10 DL=0.43*DLO**.511
GO TO 100
20 DL=0.54*DLO**.58
GO TO 100
30 DL=0.83*DLO**.808
GO TO 100
40 DL=DLO
100 LNOW=DEP/DL
PID=6.2832*DEP
LENG=LO*TANH(PID/LNOW)
DO 300 K=1,500
LENGO=LENG
LENG=LO*TANH(PID/LENGO)
IF (.005*LENGO .GE. ABS(LENGO-LENG)) GO TO 400
300 CONTINUE
400 CONTINUE
RETURN
END

```

470
480
481
482
483
490
500
510
520
530
540
550
560
570
580
590
600
610
620
630
640
650
660
670
680
690
700
710
720

```

730 FUNCTION SINH(X)
740   SINH=(EXP(X)-(1./EXP(X)))/2.
750 RETURN
760 END

```

```

770 FUNCTION COSH(X)
780   COSH=(EXP(X)+(1./EXP(X)))/2.
790 RETURN
800 END

```

```

C
820 SUBROUTINE FORCE3
830 THIS SUBROUTINE FOR REID'S SOLUTION
840 COMMON T(15),D(15),HT(15),PER,DEP,LENG,LO,H,KRUNNG(15), HORZFW(15)
850 1, HORZFO(15), VERTFD(15), VERTFU(15), GAMMA, HM, WM, LM, HORZW,
860 2 HORZO, VERTO, VERTU, RK, CM, HFT, FCRHZW, HQ(15), WQ(15), LQ(15),
870 3 HSUM
880 REAL LENG,LO, LM, LQ
890 CM = 1.8
900 HSUM = 0.
910 RK = 1.0/(COSH((2.0*3.1416*DEP)/LENG))
920 DO 25 I=1,15
930 HFT = CM*HQ(I)*WQ(I)*RK*GAMMA*453.515*H*SIN((3.1416*LQ(I))/LENG)
940 HSUM = HSUM + HFT
950 25 CONTINUE
960 RETURN
970 END

```

```

C
SUBROUTINE FORCE4
THIS SUBROUTINE FOR REID'S SOLUTION
COMMON I(15),D(15),HT(15),PER,DEP,LENG,LO,H,KRUNNO(15), HORZFW(15)
1, HORZFO(15), VERTFD(15), GAMMA, HM, WM, LM, HORZW,
2 HORZO, VERTD, VERTU, RK, CM, HFT, FORHZW, HQ(15), WQ(15), LQ(15),
3 HSUM
REAL LENG,LO, LM, LQ
CM = 0.0
17 CM = CM + 0.1
NCOUNT = 0
NCOUNT = NCOUNT + 1
HSUM = 0.
RK = 1.0/(COSH((2.0*3.1416*DEP)/LENG))
DO 25 I=1,15
HFT = CM*HQ(I)*WQ(I)*RK*GAMMA*453.515*H*SIN((3.1416*LQ(I))/LENG)
HSUM = HSUM + HFT
25 CONTINUE
IF(0.05*FORHZW .GE. ABS(FORHZW -HSUM)) GO TO 16
IF (NCOUNT .GT. 100) GO TO 16
GO TO 17
16 CONTINUE
RETURN
END
920
930
940
950
951
960
970
980
990
1000
1001
1010
1011
1020
1021
1022
1030
1040
1050
1060
1070
1080

```

RUN	DEPTH	PERIOD	YAVG	HEIGHT	D/L	L/D	H/L	VERTED	VERTFU	HORZFW	HORZFO	VERTD	VERTU	HORZM	HORZO	CM	HFT
4990	2.000	1.684	1.635	0.086	0.179	5.578	0.008	46.	44.	80.	82.	11.89	11.37	20.68	21.20	1.80	9.97E 01
5000	2.000	1.682	1.635	0.174	0.179	5.578	0.018	106.	99.	204.	200.	13.54	12.65	26.07	25.55	1.80	2.02E 02
5010	2.000	1.673	1.635	0.276	0.179	5.578	0.025	216.	196.	340.	336.	17.40	12.57	27.39	27.07	1.80	3.20E 02
5020	2.000	1.673	1.635	0.378	0.179	5.578	0.034	279.	217.	480.	452.	16.41	12.76	27.06	28.58	1.80	4.38E 02
5030	2.000	1.591	1.635	0.500	0.179	5.578	0.045	365.	299.	600.	655.	16.23	13.50	26.88	28.17	1.80	5.86E 02
5040	2.000	1.572	1.635	0.624	0.179	5.578	0.056	438.	366.	728.	800.	15.61	13.94	25.94	28.50	1.80	7.25E 02
5050	2.000	1.569	1.635	0.732	0.179	5.578	0.066	546.	460.	892.	944.	16.58	13.97	27.09	28.67	1.80	8.44E 02
5060	2.000	1.556	1.514	0.079	0.200	4.988	0.008	52.	52.	90.	70.	14.63	14.63	25.33	19.70	1.80	9.16E 01
5070	2.000	1.554	1.514	0.192	0.200	4.988	0.019	131.	130.	226.	230.	15.17	15.05	26.17	26.63	1.80	2.23E 02
5080	2.000	1.551	1.514	0.314	0.200	4.988	0.031	237.	201.	748.	784.	16.78	14.23	52.40	55.51	1.80	3.64E 02
5090	2.000	1.551	1.514	0.438	0.200	4.988	0.044	329.	259.	516.	540.	16.70	13.15	25.99	27.41	1.80	5.08E 02
5100	2.000	1.481	1.514	0.510	0.200	4.988	0.051	368.	321.	680.	676.	16.04	13.99	29.64	28.47	1.80	5.91E 02
5110	2.000	1.459	1.514	0.618	0.200	4.988	0.062	379.	353.	836.	844.	13.83	12.70	30.08	30.56	1.80	7.16E 02
5120	2.000	1.445	1.514	0.720	0.200	4.988	0.072	529.	463.	920.	912.	16.33	14.30	28.41	28.16	1.80	8.34E 02
5130	2.000	1.390	1.260	0.089	0.260	3.843	0.012	45.	40.	72.	72.	11.24	9.99	17.99	17.99	1.80	9.53E 01
5140	2.000	1.290	1.260	0.185	0.260	3.843	0.024	125.	107.	176.	170.	15.02	12.86	21.15	20.43	1.80	1.98E 02
5150	2.000	1.263	1.260	0.312	0.260	3.843	0.041	214.	214.	340.	330.	15.25	15.25	24.23	23.52	1.80	3.34E 02
5160	2.000	1.257	1.260	0.436	0.260	3.843	0.057	301.	263.	480.	466.	15.35	13.41	24.68	23.76	1.80	4.67E 02
5170	2.000	1.245	1.260	0.544	0.260	3.843	0.071	413.	313.	632.	596.	16.88	12.79	25.83	24.36	1.80	5.83E 02
5180	2.000	1.243	1.260	0.630	0.260	3.843	0.082	497.	360.	748.	716.	17.54	12.70	26.40	25.27	1.80	6.75E 02
5190	2.000	1.229	1.260	0.734	0.260	3.843	0.095	534.	437.	836.	836.	16.17	13.24	25.32	25.32	1.80	7.86E 02
5200	2.000	1.088	1.073	0.120	0.344	2.907	0.021	51.	47.	78.	74.	9.45	8.71	14.45	13.71	1.80	1.02E 02
5210	2.000	1.081	1.073	0.250	0.344	2.907	0.043	120.	129.	170.	164.	10.67	11.47	15.12	14.58	1.80	2.12E 02
5220	2.000	1.079	1.073	0.379	0.344	2.907	0.065	197.	202.	272.	310.	11.56	11.85	15.96	18.18	1.80	3.22E 02
5230	2.000	1.070	1.073	0.506	0.344	2.907	0.087	267.	262.	360.	424.	11.73	11.51	16.70	18.63	1.80	4.30E 02
5231	2.000	1.070	1.073	0.540	0.344	2.907	0.086	267.	262.	360.	422.	11.38	11.29	17.79	18.76	1.80	4.25E 02
5240	2.000	1.060	1.073	0.560	0.344	2.907	0.096	322.	308.	486.	500.	12.78	12.23	19.22	19.85	1.80	4.75E 02
5250	2.000	1.060	1.073	0.552	0.344	2.907	0.095	285.	268.	448.	480.	11.48	10.79	18.04	19.33	1.80	4.69E 02
5260	2.000	0.885	0.877	0.112	0.508	1.968	0.028	34.	36.	40.	40.	6.75	7.15	7.94	7.94	1.80	4.95E 01
5270	2.000	0.880	0.877	0.216	0.508	1.968	0.055	61.	63.	87.	81.	6.28	6.48	8.95	8.34	1.80	9.54E 01
5280	2.000	0.880	0.877	0.317	0.508	1.968	0.081	95.	94.	136.	128.	6.66	6.59	9.54	8.98	1.80	1.40E 02
5290	2.000	0.880	0.877	0.400	0.508	1.968	0.102	124.	120.	164.	160.	6.89	6.67	9.12	8.89	1.80	1.77E 02
5291	2.000	0.885	0.877	0.408	0.508	1.968	0.104	124.	118.	171.	168.	6.76	6.43	9.32	9.15	1.80	1.80E 02
5300	2.000	0.865	0.877	0.394	0.508	1.968	0.100	109.	106.	170.	154.	6.15	5.98	9.59	8.69	1.80	1.74E 02
5310	2.000	0.864	0.877	0.368	0.508	1.968	0.093	103.	100.	153.	142.	6.22	6.04	9.24	8.58	1.80	1.63E 02
5320	2.000	0.778	0.774	0.064	0.653	1.532	0.021	15.	13.	18.	10.	5.21	4.52	6.25	3.47	1.80	1.42E 01
5330	2.000	0.778	0.774	0.136	0.653	1.532	0.044	34.	38.	34.	36.	5.56	6.21	5.56	5.89	1.80	3.03E 01
5340	2.000	0.778	0.774	0.191	0.653	1.532	0.062	38.	40.	49.	49.	4.42	4.66	6.09	5.82	1.80	4.25E 01
5350	2.000	0.775	0.774	0.252	0.653	1.532	0.082	58.	51.	69.	64.	5.12	4.50	6.09	5.65	1.80	5.61E 01
5360	2.000	0.769	0.774	0.293	0.653	1.532	0.096	67.	62.	74.	72.	5.08	4.70	5.62	5.46	1.80	6.52E 01
5370	2.000	0.765	0.774	0.277	0.653	1.532	0.090	61.	64.	68.	66.	4.90	5.14	5.46	5.30	1.80	6.36E 01
5380	1.500	0.715	0.712	0.040	0.578	1.731	0.015	20.	21.	22.	22.	8.34	8.75	9.17	9.17	1.80	1.63E 01

COMPUTER OUTPUT FROM PROGRAM FOR WAVE PARAMETERS AND INERTIAL WAVE FORCES FOR MODELS OF IRREGULAR CROSS SECTION (SUBPROGRAM FORCE-3)

RUN	DEPTH	PERIOD	TANG	HEIGHT	D/L	L/D	M/L	VERTFU	HORZFV	HORZFD	VERTIC	VERTU	HORZU	HORZV	HORZD	CM	MFT
4990	2.000	1.684	1.635	0.086	0.179	5.578	0.008	46.	80.	82.	11.89	11.37	20.68	21.20	1.40	7.74E 01	
5000	2.000	1.682	1.635	0.174	0.179	5.578	0.016	99.	204.	200.	13.54	12.65	26.07	25.55	1.80	2.02E 02	
5010	2.000	1.673	1.635	0.276	0.179	5.578	0.034	116.	340.	336.	17.40	12.57	27.39	27.07	1.90	3.38E 02	
5020	2.000	1.673	1.635	0.378	0.179	5.578	0.053	279.	460.	452.	16.41	12.76	27.06	26.58	1.80	4.39E 02	
5030	2.000	1.671	1.635	0.500	0.179	5.578	0.075	365.	600.	656.	16.23	13.30	26.68	29.17	1.80	5.80E 02	
5040	2.000	1.672	1.635	0.624	0.179	5.578	0.096	438.	728.	800.	15.61	13.04	25.94	28.50	1.80	7.23E 02	
5050	2.000	1.669	1.635	0.752	0.179	5.578	0.066	546.	892.	944.	16.58	13.97	27.09	28.67	1.80	8.44E 02	
5060	2.000	1.556	1.514	0.079	0.200	4.988	0.008	52.	90.	70.	14.63	14.63	25.33	19.70	1.70	8.65E 01	
5070	2.000	1.554	1.514	0.192	0.200	4.988	0.019	131.	226.	230.	15.17	15.05	26.17	26.63	1.80	2.23E 02	
5080	2.000	1.551	1.514	0.314	0.200	4.988	0.031	237.	400.	384.	16.78	14.23	52.40	55.51	3.50	7.08E 02	
5090	2.000	1.551	1.514	0.438	0.200	4.988	0.044	329.	512.	540.	16.70	13.15	25.99	27.41	1.80	5.08E 02	
5100	2.000	1.581	1.514	0.510	0.200	4.988	0.051	368.	680.	676.	16.04	13.99	29.64	29.47	2.00	6.57E 02	
5110	2.000	1.459	1.514	0.618	0.200	4.988	0.062	379.	836.	844.	13.63	12.70	30.08	30.36	2.00	7.94E 02	
5120	2.000	1.445	1.514	0.720	0.200	4.988	0.072	529.	920.	912.	16.33	14.30	28.41	28.16	1.90	8.81E 02	
5130	2.000	1.290	1.260	0.089	0.260	3.843	0.012	45.	72.	72.	11.24	9.99	17.99	17.99	1.30	6.88E 01	
5140	2.000	1.290	1.260	0.185	0.260	3.843	0.024	125.	176.	170.	15.02	12.86	21.15	20.43	1.60	1.76E 02	
5150	2.000	1.263	1.260	0.312	0.260	3.843	0.041	214.	340.	330.	15.25	15.25	24.23	23.52	1.80	3.34E 02	
5160	2.000	1.257	1.260	0.436	0.260	3.843	0.057	301.	480.	466.	15.35	13.41	24.48	23.76	1.80	4.67E 02	
5170	2.000	1.245	1.260	0.544	0.260	3.843	0.071	413.	632.	596.	16.88	12.79	25.83	24.36	1.90	6.15E 02	
5180	2.000	1.243	1.260	0.630	0.260	3.843	0.082	497.	748.	716.	17.54	12.70	26.40	25.27	1.90	7.12E 02	
5190	2.000	1.229	1.260	0.734	0.260	3.843	0.095	534.	836.	830.	16.17	13.24	25.32	25.32	1.90	8.30E 02	
5200	2.000	1.088	1.073	0.120	0.344	2.907	0.021	51.	78.	74.	9.45	8.71	14.45	13.71	1.40	7.92E 01	
5210	2.000	1.081	1.073	0.250	0.344	2.907	0.043	120.	170.	164.	10.67	11.87	15.12	14.58	1.40	1.63E 02	
5220	2.000	1.079	1.073	0.379	0.344	2.907	0.065	197.	262.	310.	11.54	11.85	15.96	18.18	1.50	2.68E 02	
5230	2.000	1.070	1.073	0.506	0.344	2.907	0.087	267.	360.	424.	11.73	11.51	16.70	18.63	1.60	3.82E 02	
5231	2.000	1.070	1.073	0.500	0.344	2.907	0.086	254.	400.	422.	11.98	11.29	17.79	18.74	1.70	4.01E 02	
5240	2.000	1.060	1.073	0.560	0.344	2.907	0.096	322.	484.	500.	12.78	12.23	19.22	19.85	1.80	4.75E 02	
5250	2.000	1.060	1.073	0.552	0.344	2.907	0.095	285.	446.	480.	11.48	10.79	18.04	19.33	1.70	4.43E 02	
5260	2.000	0.885	0.877	0.112	0.508	1.968	0.028	34.	40.	40.	6.75	7.15	7.94	7.94	1.40	3.85E 01	
5270	2.000	0.880	0.877	0.216	0.508	1.968	0.055	61.	87.	81.	6.28	6.58	8.95	8.34	1.60	4.48E 01	
5280	2.000	0.880	0.877	0.317	0.508	1.968	0.081	95.	136.	128.	6.66	6.59	9.34	8.98	1.70	1.34E 02	
5290	2.000	0.880	0.877	0.400	0.508	1.968	0.102	124.	180.	160.	6.89	6.57	9.12	8.89	1.60	1.57E 02	
5291	2.000	0.885	0.877	0.408	0.508	1.968	0.104	124.	118.	168.	6.76	6.43	9.32	9.15	1.70	1.70E 02	
5300	2.000	0.865	0.877	0.394	0.508	1.968	0.100	109.	170.	154.	6.15	5.98	9.59	8.69	1.70	1.64E 02	
5310	2.000	0.864	0.877	0.368	0.508	1.968	0.093	103.	153.	142.	6.22	6.04	9.24	8.56	1.70	1.53E 02	
5320	2.000	0.778	0.774	0.064	0.653	1.532	0.021	15.	18.	10.	5.21	4.52	6.25	3.47	2.20	1.74E 01	
5330	2.000	0.778	0.774	0.136	0.653	1.532	0.044	36.	34.	36.	5.56	6.21	5.56	5.89	2.00	2.35E 01	
5340	2.000	0.778	0.774	0.191	0.653	1.532	0.062	38.	40.	50.	4.42	4.66	5.70	5.82	2.00	4.17E 01	
5350	2.000	0.775	0.774	0.252	0.653	1.532	0.082	58.	51.	69.	5.12	4.50	6.09	6.65	2.00	6.85E 01	
5360	2.000	0.769	0.774	0.293	0.653	1.532	0.096	57.	62.	72.	5.08	4.70	5.62	5.46	2.00	7.24E 01	
5370	2.000	0.765	0.774	0.277	0.653	1.532	0.090	51.	64.	66.	4.90	5.14	5.46	5.30	1.90	6.51E 01	
5380	1.500	0.715	0.712	0.040	0.576	1.731	0.015	20.	22.	22.	8.34	8.75	9.17	9.17	2.40	2.18E 01	

COMPUTER OUTPUT FROM PROGRAM FOR WAVE PARAMETERS AND INERTIAL WAVE FORCES FOR MODELS OF IRREGULAR CROSS SECTION (SUBPROGRAM FORCE-4)

APPENDIX VIII

COMPUTER PROGRAM FOR FORCE COMPUTATION BY MORISON EQUATION

```

C
C
C PROGRAM DECK 5          DATA DECK 2          MODEL M-8          14 APRIL 1970
C *****                *****                *****                *****
C
C *****                *****                *****                *****
C
C G. E. SHANK, COASTAL AND OCEAN DIVISION, DEPARTMENT OF CIVIL ENGINEERING
C
C CE 691 THESIS RESEARCH          WAVE FORCES ON SUBMERGED OBJECTS
C *****                *****                *****                *****
C *****                *****                *****                *****
C
C KRUNNO = RUN NUMBER (LAST DIGIT IS FOR RERUN 1=A, 2=B, ETC)
C
C   T = PERIOD IN MAIN PROGRAM
C   PER = PERIOD IN SUBROUTINE PROF 1
C   D = WATER DEPTH IN MAIN PROGRAM
C   DEP = WATER DEPTH IN SUBROUTINE PROF 1
C   HT = WAVE HEIGHT IN MAIN PROGRAM
C   H = WAVE HEIGHT IN SUBROUTINE PROF 1
C   LO = COMPUTED DEEP WATER WAVE LENGTH
C   LENG = COMPUTED SHALLOW WATER (ACTUAL) WAVE LENGTH
C   TAVG = AVERAGE PERIOD FOR A GROUP OF WAVES RUN AT A CONSTANT PERCENT
C
C   LINES = SPEED PADDLE SETTING (VARIATION LESS THAN FIVE PERCENT)
C   HORZFW = MEASURED HORIZONTAL FORCE (IN GRAMS) IN DIRECTION OF WAVES
C   HORZFO = MEASURED HORIZONTAL FORCE (IN GRAMS) IN OPPOSITE DIRECT FROM WAVE
C   VERTFD = MEASURED VERTICAL FORCE (IN GRAMS) DOWN
C   VERTFU = MEASURED VERTICAL FORCE (IN GRAMS) UP

```

```

C   HORZW = DIMENSIONLESS HORIZONTAL FORCE IN DIRECTION OF WAVES
C   HORZO = DIMENSIONLESS HORIZONTAL FORCE IN OPPOSITE DIRECTION FROM WAVES
C   VERTD = DIMENSIONLESS VERTICAL FORCE DOWN
C   VERTU = DIMENSIONLESS VERTICAL FORCE UP
C   GAMMA = UNIT WEIGHT OF WATER
C   HM = HEIGHT OF MODEL (IN FEET)
C   WM = WIDTH OF MODEL (IN FEET)
C   LM = LENGTH OF MODEL (IN FEET)
C   RK = K ON FIGURE 16 IN REID'S PAPER
C   CM = INERTIAL COEFFICIENT
C   HFT = TOTAL COMPUTED HORIZONTAL FORCE
C   HFI = COMPUTED FORCE IN MORISON EQUATION DUE TO INERTIA
C   HFD = COMPUTED FORCE IN MORISON EQUATION DUE TO DRAG
C   FORHZW = HORZFW
C   CD = DRAG COEFFICIENT
C   RHO = DENSITY
C   TIME = PERIOD (IN MM) FROM RECORDER PAPER
C   TLAG1 = TIME (IN MM) FROM WAVE CREST TO MAX HORIZONTAL FORCE
C           IN DIRECTION OF WAVE TRAVEL
C   TIMEAV = AVERAGE PERIOD FOR SET OF RUNS (OF A GIVEN PERIOD)
C   TLAGIA = AVERAGE LAG FROM CREST TO MAX HORIZONTAL FORCE
C   TLAGIR = TIMEAV - TLAGIA
C
COMMON T(15),D(15),HT(15),PER,DEP,LENG,LO,H,KRUNNC(15), HORZFW(15)
1, HORZFO(15), VERTFD(15), VERTFU(15), GAMMA, HM, WM, LM, HORZW,
2 HORZO, VERTD, VERTU, RK, CM, HFT, FORHZW, TIME(15), TLAG1(15),
3 TTIME, TLAG1, TIMEAV, TLAGIA, CD, RHO, TLAGIR, HFI, HFD
REAL LENG,LO, LM
WRITE (6,200)
200 FORMAT (1H1,'RUN DEPTH PERIOD TAVG HEIGHT O/L L/D H/L
1VERTFD VERTFU HORZFW HORZFO CD CM HFD HFI HFT',/)
LINES = 2

```

10
11
12
13
20
30
40
50
60

```

61 READ(5,102) HM,WM,LM
62 FORMAT(F5.3, 2X, F5.3, 2X, F5.3)
63 GAMMA = 62.4
64 RHO = 1.94
70 4 READ(5,100)N
80 100 FORMAT (I2)
90 IF (N.LE. 0.0) STOP
91 CD = (-0.5)
100 DO 1 I = 1, N
110 READ (5,101)KRUNNO(I), T(I), D(I), HT(I), VERTFD(I), VERTFU(I),
111 1 HORZFW(I), HORZFO(I), TIME(I), TLAG1(I)
120 101 FORMAT (I4, 2X, F5.3, 2X, F5.3, 2X, F5.3, 2X, F3.0, 2X, F3.0, 2X,
121 1 F4.0, 2X, F4.0, 2X, F5.2, 2X, F5.2)
130 1 CONTINUE
140 TSUM = 0.
141 TTIME = 0.0
142 TLAG1 = 0.0
150 DO 2 J = 1,N
160 TSUM = TSUM + T(J)
161 TTIME = TTIME + TIME(J)
162 TLAG1= TLAG1 + TLAG1(J)
170 2 CONTINUE
180 TAVG = TSUM/N
181 TIMEAV = TTIME/N
182 TLAGIA = TLAG1/N
183 FLAGIR = TIMEAV - TLAGIA
190 PER = TAVG
191 DO 33 KK = 1,11
192 CD = CD + 0.5
200 DO 3 K = 1, N
210 DEP = D(K)
220 H = HT(K)
221 FORH2W = HORZFW(K)

```

```

230 CALL PROF1
231 CALL FORCE5

C
C THE NEXT FOUR CARDS ARE FOR ALL MODELS EXCEPT FLAT PLATE
C THEY CONVERT FORCE IN GRAMS TO DIMENSIONLESS FORCE.
C

HORZW = HORZFW(K)*2.0*0.002205*DEP*(LM**3)/(GAMMA**H*(HM**6))
HORZO = HORZFO(K)*2.0*0.002205*DEP*(LM**3)/(GAMMA**H*(HM**6))
VERTD = VERTFD(K)*2.0*0.002205*DEP*(LM**3)/(GAMMA**H*(HM**6))
VERTU = VERTFU(K)*2.0*0.002205*DEP*(LM**3)/(GAMMA**H*(HM**6))
DL = DEP/LENG
SLD = LENG/DEP
HL = H/LENG
IF (LINES .LT. 50) GO TO 10
11 WRITE (6,200)
    LINES = 2
    GO TO 9
10 WRITE (6,201)KRUNNO(K), D(K), T(K), PER, H, DL, SLD, HL, VERTFD(K)
    1, VERTFU(K), HORZFW(K), HORZFO(K),
    2 CD, CM, HFD, HFI, HFT
201 FORMAT (1X, I4, 2X, F5.3, 2X, F5.3, 2X, F5.3, 2X, F5.3, 2X, F5.3,
1 2X, F5.3, 2X, F5.3, 2X, F4.0, 2X, F4.0, 2X, F5.0, 2X, F5.0, 2X,
2 F5.2, 2X, F5.2, 2X, F5.0, 2X, F5.0, 2X, F5.0)
    LINES = LINES + 1
    IF (LINES .EQ. 50) GO TO 11
9 CONTINUE
3 CONTINUE
WRITE (6,202)
202 FORMAT (1X,/)
    LINES = LINES + 1
    IF (LINES .EQ. 50) GO TO 30
    GO TO 33
30 WRITE (6, 200)

```

230
231
231
232
233
234
240
250
260
270
280
290
300
310
311
312
320
330
331
340
350
360
370
380
390
400
410
420
430

```

440 LINES = 2
441 33 CONTINUE
450 GO TO 4
460 END

470 SUBROUTINE PROF1
480 COMMON T(15),D(15),HT(15),PER,DEP,LENG,LO,H,KRUNNO(15), HDRZFW(15)
481 1, HORZFO(15), VERTFD(15), VERTFU(15), GAMMA, HM, WM, LM, HORZW,
482 2 HORZO, VERTD, VERTU, RK, CM, HFI, FORHZW, TIME(15), TLAGI(15),
483 3 TTIME, TLAGI, TIMEAV, TLAGIA, CD, RHO, TLAGIR, HFI, HFD
490 REAL LO, LENG,LNDW,LENGO, LM
500 LO=5.12*PER**2
510 DLO=DEP/LO
520 IF (DLO-.04) 10,1,1
530 1 IF(DLO-.15) 20,2,2
540 2 IF (DLO-.39) 30,40,40
550 10 DL=0.43*DLO**.511
560 GO TO 100
570 20 DL=0.54*DLO**.58
580 GO TO 100
590 30 DL=0.83*DLO**.808
600 GO TO 100
610 40 DL=DLO
620 100 LNDW=DEP/DL
630 PID=6.2832*DEP
640 LENG=LO*TANH(PID/LNDW)
650 DO 300 K=1,500
660 LENGO=LENG
670 LENG=LO*TANH(PID/LENGO)
680 IF (.005*LENGO .GE. ABS(LENGO-LENG)) GO TO 400
690 300 CONTINUE
700 400 CONTINUE
710 RETURN
720 END

```

```

730 FUNCTION SINH(X)
740 SINH=(EXP(X)-(1./EXP(X)))/2.
750 RETURN
760 END

```

```

770 FUNCTION COSH(X)
780 COSH=(EXP(X)+(1./EXP(X)))/2.
790 RETURN
800 END

```

```

820 SUBROUTINE FORCE1
830 THIS SUBROUTINE FOR REID'S SOLUTION CONSTANT X-SECTION MODELS ONLY
840 COMMON T(15),D(15),HT(15),PER,DEP,LENG,LO,H,KRUNNO(15), HORZFW(15)
850 1, HORZFO(15), VERTFD(15), VERTFU(15), GAMMA, HM, WM, LM, HORZW,
851 2 HORZO, VERTD, VERTU, RK, CM, HFT, FORHZW, TIME(15), TLAG1(15),
860 3 TTIME, TLAG1, TIMEAV, TLAGIA, CD, RHO, TLAGIR, HFI, HFD
870 REAL LENG,LO, LM
880 CM = 1.8
890 RK = 1.0/(COSHI(2.0*3.1416*DEP)/LENG))
900 HFT = CM*HM*WM*RK*GAMMA*453.515 *H *SIN((3.1416*LM)/LENG)
910 RETURN
END

```

C

```

C
SUBROUTINE FORCE2
THIS SUBROUTINE FOR REID'S SOLUTION CONSTANT X-SECTION MODELS ONLY
COMMON T(15),D(15),HT(15),PER,DEP,LENG,LO,H,KRUNNO(15), HORZFW(15)
1, HORZFO(15), VERTFD(15), VERTFU(15), GAMMA, HM, WM, LM, HORZW,
2 HORZO, VERTD, VERTU, RK, CM, HFT, FORHZW, TIME(15), TLAG1(15),
3 TTIME, TLAG1, TIMEAV, TLAG1A, CD, RHO, TLAGIR, HFI, HFD
REAL LENG,LD, LM
CM = 0.0
17 CM = CM + 0.1
NCOUNT = 0
NCOUNT = NCOUNT + 1
RK = 1.0/(COSH((2.0*3.1416*DEP)/LENG))
HFT = CM*HM*WM*WK*GAMMA*453.515 *H *SIN((3.1416*LM)/LENG)
IF(0.05*FORHZW .GE. ABS(FORHZW - HFT)) GO TO 16
IF (NCOUNT .GT. 100) GO TO 16
GO TO 17
16 CONTINUE
RETURN
END
920
930
940
950
951
960
970
980
990
1000
1010
1020
1030
1040
1050
1060
1070
1080

```

```

1090
SUBROUTINE FORCES
THIS SUBROUTINE COMPUTES FORCE BY THE MORISON EQUATION AND
GIVEN A VALUE FOR CD COMPUTES CM BY COMPARING COMPUTED FORCES TO
ACTUAL FORCES
COMMON T(15),D(15),HT(15),PER,DEP,LENG,LO,H,KRUNNO(15), HORZFW(15)
1, HORZFO(15), VERTFO(15), VERTFU(15), GAMMA, HM, WM, LM, HORIZW,
2 HORZO, VERTD, VERTU, RK, CM, HFI, FORHZW, TIME(15), TLAG1(15),
3 TIME, TLAGI, TIMEAV, TLAGIA, CD, RHO, TLAGIR, HFI, HFD
REAL LENG,LO, LM
CM = (-0.1)
17 CM = CM + 0.2
NCOUNT = 0
NCOUNT = NCOUNT + 1
HFI = 453.515 * ((CM * RHO * WM * LM * (-19.739) * H *
1 (SIN((6.283 * TLAGIR)/TIMEAV)) * (SINH((6.283 * HM)/LENG)))/
2 ((PER ** 2) * (SINH((6.283 * DEP)/LENG)) * (6.283/LENG))
HFD = 453.515 *
1 WM * ((13.1416 * H)/PER) ** 2 * ((COS((6.283 * TLAGIR)/TIMEAV)) /
2 (SINH((6.283*DEP)/LENG))) ** 2 *
3 ((SINH((12.566 * HM)/LENG))/4.0) + ((13.1416 * HM)/LENG))
HFI = HFI + HFD
IF(0.05*FORHZW .GE. ABS(FORHZW - ABS(HFI))) GO TO 16
IF (ABS(HFI) .GE. FORHZW) GO TO 16
IF (NCOUNT .GT. 100) GO TO 16
GO TO 17
16 CONTINUE
RETURN
END
1100
1110
1120
1130
1131
1150
1160
1170
1180
1190
1200
1210
1211
1220
1221
1230
1231
1240
1241
1250
1260
1270
1280
1290

```

RUN	DEPTH	PERIOD	TAVG	HEIGHT	D/L	L/D	H/L	VERTED	VERTU	HORIZFW	HORIZFO	CD	CM	HFED	HFI	HFT
940	2.000	1.680	1.621	0.080	0.182	5.496	0.007	33.	33.	94.	98.	0.0	1.90	0.	96.	96.
950	2.000	1.670	1.621	0.174	0.182	5.496	0.016	92.	73.	224.	220.	0.0	2.10	0.	231.	231.
960	2.000	1.670	1.621	0.248	0.182	5.496	0.023	145.	118.	366.	350.	0.0	2.30	0.	361.	361.
970	2.000	1.650	1.621	0.348	0.182	5.496	0.032	207.	170.	528.	480.	0.0	2.30	0.	506.	506.
980	2.000	1.580	1.621	0.480	0.182	5.496	0.044	294.	249.	720.	680.	0.0	2.30	0.	698.	698.
990	2.000	1.560	1.621	0.620	0.182	5.496	0.056	288.	259.	850.	850.	0.0	2.10	0.	823.	823.
1000	2.000	1.540	1.621	0.710	0.182	5.496	0.065	331.	313.	1000.	1000.	0.0	2.30	0.	1033.	1033.
940	2.000	1.680	1.621	0.080	0.182	5.496	0.007	33.	33.	94.	98.	0.50	1.90	0.	96.	96.
950	2.000	1.670	1.621	0.174	0.182	5.496	0.016	92.	73.	224.	220.	0.50	2.10	1.	231.	232.
960	2.000	1.670	1.621	0.248	0.182	5.496	0.023	145.	118.	366.	350.	0.50	2.30	1.	361.	362.
970	2.000	1.650	1.621	0.348	0.182	5.496	0.032	207.	170.	528.	480.	0.50	2.30	2.	506.	508.
980	2.000	1.580	1.621	0.480	0.182	5.496	0.044	294.	249.	720.	680.	0.50	2.30	4.	698.	702.
990	2.000	1.560	1.621	0.620	0.182	5.496	0.056	288.	259.	850.	850.	0.50	2.30	7.	823.	830.
1000	2.000	1.540	1.621	0.710	0.182	5.496	0.065	331.	313.	1000.	1000.	0.50	2.10	9.	943.	952.
940	2.000	1.680	1.621	0.080	0.182	5.496	0.007	33.	33.	94.	98.	1.00	1.90	0.	96.	96.
950	2.000	1.670	1.621	0.174	0.182	5.496	0.016	92.	73.	224.	220.	1.00	2.10	1.	231.	232.
960	2.000	1.670	1.621	0.248	0.182	5.496	0.023	145.	118.	366.	350.	1.00	2.30	2.	361.	363.
970	2.000	1.650	1.621	0.348	0.182	5.496	0.032	207.	170.	528.	480.	1.00	2.30	4.	506.	510.
980	2.000	1.580	1.621	0.480	0.182	5.496	0.044	294.	249.	720.	680.	1.00	2.30	8.	698.	706.
990	2.000	1.560	1.621	0.620	0.182	5.496	0.056	288.	259.	850.	850.	1.00	2.10	13.	823.	837.
1000	2.000	1.540	1.621	0.710	0.182	5.496	0.065	331.	313.	1000.	1000.	1.00	2.10	17.	943.	960.
940	2.000	1.680	1.621	0.080	0.182	5.496	0.007	33.	33.	94.	98.	1.50	1.90	0.	96.	96.
950	2.000	1.670	1.621	0.174	0.182	5.496	0.016	92.	73.	224.	220.	1.50	2.10	2.	231.	233.
960	2.000	1.670	1.621	0.248	0.182	5.496	0.023	145.	118.	366.	350.	1.50	2.30	3.	361.	364.
970	2.000	1.650	1.621	0.348	0.182	5.496	0.032	207.	170.	528.	480.	1.50	2.30	6.	506.	512.
980	2.000	1.580	1.621	0.480	0.182	5.496	0.044	294.	249.	720.	680.	1.50	2.30	12.	698.	710.
990	2.000	1.560	1.621	0.620	0.182	5.496	0.056	288.	259.	850.	850.	1.50	2.10	20.	823.	843.
1000	2.000	1.540	1.621	0.710	0.182	5.496	0.065	331.	313.	1000.	1000.	1.50	2.10	26.	943.	969.
940	2.000	1.680	1.621	0.080	0.182	5.496	0.007	33.	33.	94.	98.	2.00	1.90	0.	96.	97.
950	2.000	1.670	1.621	0.174	0.182	5.496	0.016	92.	73.	224.	220.	2.00	2.10	2.	231.	233.
960	2.000	1.670	1.621	0.248	0.182	5.496	0.023	145.	118.	366.	350.	2.00	2.30	4.	361.	365.
970	2.000	1.650	1.621	0.348	0.182	5.496	0.032	207.	170.	528.	480.	2.00	2.30	8.	506.	514.
980	2.000	1.580	1.621	0.480	0.182	5.496	0.044	294.	249.	720.	680.	2.00	2.30	16.	698.	714.
990	2.000	1.560	1.621	0.620	0.182	5.496	0.056	288.	259.	850.	850.	2.00	2.10	26.	823.	850.
1000	2.000	1.540	1.621	0.710	0.182	5.496	0.065	331.	313.	1000.	1000.	2.00	2.10	34.	943.	977.
940	2.000	1.680	1.621	0.080	0.182	5.496	0.007	33.	33.	94.	98.	2.50	1.90	1.	96.	97.
950	2.000	1.670	1.621	0.174	0.182	5.496	0.016	92.	73.	224.	220.	2.50	2.10	3.	231.	234.
960	2.000	1.670	1.621	0.248	0.182	5.496	0.023	145.	118.	366.	350.	2.50	2.30	5.	361.	366.
970	2.000	1.650	1.621	0.348	0.182	5.496	0.032	207.	170.	528.	480.	2.50	2.30	10.	506.	517.
980	2.000	1.580	1.621	0.480	0.182	5.496	0.044	294.	249.	720.	680.	2.50	2.30	20.	698.	718.
990	2.000	1.560	1.621	0.620	0.182	5.496	0.056	288.	259.	850.	850.	2.50	2.10	33.	823.	856.
1000	2.000	1.540	1.621	0.710	0.182	5.496	0.065	331.	313.	1000.	1000.	2.50	2.10	43.	943.	986.

COMPUTER OUTPUT FROM PROGRAM FOR WAVE PARAMETERS AND INERTIAL AND DRAG WAVE FORCES COMPUTED BY THE MORISON EQUATION (SUBPROGRAM FORCE-5)

