

CIRCULATING COPY
Sea Grant Depository

THE DESIGN AND ANALYSIS
OF A
SUBMERGED, BUOYANT, ANCHORED PIPELINE
FOR TRANSPORTING NATURAL GAS
THROUGH THE DEEP OCEAN

A Report to
The National Science Foundation Sea Grant Office
(Contract No. GH-61)
and
The Office of Naval Research
(Contract No. N00014-67-A-0158-004)

By
Godfrey H. Savage
August, 1970

DEPARTMENT OF PETROLEUM ENGINEERING
SCHOOL OF EARTH SCIENCES

STANFORD UNIVERSITY, STANFORD, CALIFORNIA

CIRCULATING COPY
Sea Grant Depository

THE DESIGN AND ANALYSIS
OF A
SUBMERGED, BUOYANT, ANCHORED PIPELINE
FOR TRANSPORTING NATURAL GAS
THROUGH THE DEEP OCEAN

A Report to
The National Science Foundation Sea Grant Office
(Contract No. GH-61)
and
The Office of Naval Research
(Contract No. N00014-67-A-0158-004)

By
Godfrey H. Savage
August, 1970

To Joanne

ACKNOWLEDGMENTS

After my wife, Joanne Goodhue Savage, six men share the primary credit or blame for this document's final completion. Professor Sullivan S. Marsden who has patiently and thoroughly served the role of principal faculty advisor as well as active participant in the assemblage of many valuable background and reference documents; Dr. J. B. Hersey, formerly of the Woods Hole Oceanographic Institution and now of the Office of Naval Research, who, with Professor J. Harvey Evans of the Department of Naval Architecture and Marine Engineering of MIT, supported the initial research in 1964 and 1965; Professor John E. Arnold (deceased, former Director of The Design Division, Mechanical Engineering Department, Stanford University) who served as the first faculty advisor on the long road; Mr. Willard Bascom, now President of Ocean Science and Engineering Inc., who was my first and demanding mentor in the ocean; and finally, Professor John Isaacs, Scripps Institution of Oceanography, whose wise career counsel and support at critical junctures in 1960, 1961, and 1963 have proven invaluable.

I am almost equally indebted to Professor Robert L. Street, Civil Engineering Department, Stanford University whose patient and always constructively critical review of

all aspects of this research has been most valuable and rewarding. I am grateful to him and to Professor Frank Miller, Chairman of the Petroleum Engineering Department for serving on my reading committee with Professor Marsden. Professor H. J. Ramsey, Petroleum Engineering Department, also offered generous assistance on the gas pipeline aspects of the work.

The Bechtel Corporation in the persons of Mr. Sam Small, Mr. Charles Arnold, Mr. Jolly Dwyer, Mr. John Giese and Mr. Lee Snyder contributed much to the report; supplying both valuable industry information on markets, costs and methods as well as encouragement by their interest.

Other companies and individuals who should be mentioned particularly are Mr. Pierre Boutin, graduate assistant who made valuable contributions with his computer analyses of the pipeline pressures and buoyancy factors, and also of the final return on investment estimates, the Corning Glass Company, U.S. Steel Corporation, Rohr Corporation, Interstate Electronics Inc., General Motors Corporation, Woods Hole Oceanographic Institution, the U.S. Navy Office of Naval Research, Professor E. E. Allmendinger of the University of New Hampshire, Mr. Subash Pahuja of the University of New Hampshire, and Dr. R. W. Corell of the University of New Hampshire.

There are a host of other people who should be acknowledged, but then, the certain failure to mention someone would be more glaring. However, it is necessary to acknowledge the remarkable assistance of Mrs. Rosanne Saussothe who not only typed this document, but deciphered it from the rough draft. She did much beyond her duty to effect the final result.

Finally, my thanks to my three children, Wendy-Jo, William and Heidi for the time I took from them to write this tome, and for being good members of the team.

Financial assistance for the work has been provided by the Graduate Division of the National Science Foundation, the Sea Grant Office of the National Science Foundation, the Office of Naval Research, the School of Earth Sciences of Stanford University, the University of New Hampshire, and the Bechtel Corporation of San Francisco, California.

ABSTRACT

The concept of buoyant, anchored structures is proposed as having unique advantages over present conventional bottom-mounted, load bearing structures in the ocean environment. The particular case of a submerged, buoyant pipeline, anchored below the surface energy effects for the purpose of transporting natural gas from North Africa to Southern Europe is technically and economically evaluated.

A design, mathematical model of the pipeline with its anchoring system is presented. A typical segment of the model is analyzed to determine the maximum stresses developed in the pipeline and in the anchoring cables and the maximum motions of both the pipeline and the anchoring cables when subjected to forces due to ocean currents, surface wave action and buoyancy. The method of imaginary reactions, combined with the method of successive approximations, is used in these static analyses and computer programs are presented together with the assumptions used in the analysis. The model is given structural authenticity because it is based upon successful full scale ocean tests of the basic trimoored anchoring station component using steel cables and glass floatation units.

A mathematical model of the ocean current velocity versus depth that exists for the Mediterranean location is presented. It is based upon the current measurements that have been made in the area and information documented by physical oceanographers who have studied the area. This model is used to determine the drag forces used in the analysis of the structural model of the pipeline and its anchoring system.

With consideration for specific limitations on cable sizes, pipe welding speeds, and other state-of-the-art constraints on offshore construction, and assuming several rate levels of gas delivery, the several probable diameter pipelines are incorporated into specific pipeline and anchor systems and analyzed to determine the required cable spacing, cable sizes, anchor sizes and the other important cost determining factors, including installation costs.

Finally, for various levels of predicted market demand (maximum gas rate), the preliminary capital investment and cost analysis of the pipeline system required is made with assumptions explained to forecast a simple return on investment. Critical considerations such as safety factors selected and the need for preventative maintenance are incorporated, quantitatively, in this economic evaluation.

TABLE OF CONTENTS

	<u>Page</u>
ACKNOWLEDGEMENTS	v
ABSTRACT	viii
LIST OF FIGURES	xiv
LIST OF TABLES	xv
1 INTRODUCTION	1
2 STATEMENT OF PROBLEM	9
3 LITERATURE AND INDUSTRY SURVEY	12
4 PIPELINE STRUCTURAL ANALYSIS	18
4.1 ANALYTICAL MODEL OF THE FLOATING PIPELINE AND ITS CABLE ANCHORING SYSTEM	25
4.1.1 The Floating Pipeline Sublength Between Buoyant Towers	25
4.1.1a Determination of the Static Configuration and Tower Reactions for a Pipeline Sublength	32
4.1.1b The Stresses in a Pipeline Sublength	42
4.1.2 Motions of and Stresses in the Buoyant Towers	50
4.1.2a Method of Analysis of Motion and Stresses on the Towers	51
4.2 EXTERNAL FORCE ACTING UPON THE PIPELINE SYSTEM	61
4.2.1 Non Gravity Forces Acting	61
4.2.1a Current Forces in the Mediterranean Environment	61

TABLE OF CONTENTS

	<u>Page</u>
4.2.1b Wave Forces in the Mediterranean Environment	73
4.2.1c Special Forces	80
4.2.2 Gravity Forces Acting	86
4.2.2a Tower Gravity Forces	87
4.2.2b The Pipeline Sublength Gravity Forces	89
4.3 DETERMINING THE TOWER SPACING, TOWER COMPONENT SIZES, AND OTHER SIGNIFICANT DESIGN PARAMETERS OF A PIPELINE SYSTEM	98
4.3.1 The Final Analytical Model	106
4.3.2 Procedure of Design Analysis	109
5 INVESTMENT, COST AND RETURN ON INVESTMENT ESTIMATES	113
5.1 ESTIMATED INVESTMENT	114
5.1.1 Tower Materials	115
5.1.1a The Apex Buoys	115
5.1.1b Cables	116
5.1.1c Cable Buoyancy	116
5.1.1d Fittings	116
5.1.1e Anchors	117
5.1.1f Total Tower Material	117
5.1.2 Tower Installations	117
5.1.3 Pipeline Materials Including Intermediate Buoys, Cables, Anchors	118

TABLE OF CONTENTS

	<u>Page</u>
5.1.3a The Pipe	118
5.1.3b Intermediate and Secondary Tower Buoys	119
5.1.3c Intermediate Cables	119
5.1.3d Intermediate Cable Buoyancy Elements . .	120
5.1.3e Intermediate Anchors	120
5.1.3f Fittings	120
5.1.3g Total Pipeline Material Costs	120
5.1.4 Pipe and Intermediate Cable Installation Costs	121
5.1.5 Safety Valves, Explosive Flanges and Instrumentation	121
5.1.6 The Bottom Mounted Pipe	122
5.1.7 The Pumping Stations	122
5.1.8 The Total Investment	122
5.2 ESTIMATED COSTS	124
5.2.1 Maintenance and Inspection Costs	124
5.2.2 Insurance and Interest	125
5.2.3 Other Fixed Costs	127
5.3 VARIABLE COSTS (Bechtel Corporation) . .	127
5.4 RETURN ON INVESTMENT	127
6 DISCUSSION	131
7 CONCLUSIONS	137
BIBLIOGRAPHY	139

TABLE OF CONTENTS

	<u>Page</u>
APPENDIX I Computer Programs to Compute Pipeline and Tower Configurations and Stresses	146
APPENDIX II A Technical Economic Analysis of a Gas Transmission Line and the Physical Variables it Offers in the Design and Construction of a Submerged Buoyant Pipeline	192
APPENDIX III Letters and Interviews Records Concerning Currents and Waves in the Mediterranean Sea	242
APPENDIX IV Installation Methodology	246
APPENDIX V Safety Devices	253
APPENDIX VI Computer Program to Compute Estimated Return on Investment for Various Gas Prices and Expected Pipeline Life	256

LIST OF FIGURES

<u>Figure</u>		<u>Page</u>
1-1	Past, Present and Projected Sources of Energy Consumed in Western Europe	4
3-1	Sea Spider, A Trimooored Buoy with Neutrally Buoyant Steel Legs	14
4-1	Location of Proposed Mediterranean Pipeline and Pumping Stations	19
4-2	Artist's Drawing of the Submerged, Buoyant, Anchored Pipeline	20
4-3	Schematic Drawing of Transition From Bottom Mounted to Floating Pipeline with Tower Details	22
4-4	Schematic of a Pipeline Sublength Between Two Buoyant Towers Under a Current Load . .	23
4-5	Plan View of a Pipeline Sublength Subjected to Current Distributed Load and Cable Forces	27
4-6	Plan View of a Pipeline Sublength Showing Lumping Stations and Lumped Forces	30
4-7	Plan View of Pipeline Sublength Model Configuration when External Reactions Are Not Correct	35
4-8	Plan View of Configuration of Pipeline Sublength Caused by Current Forces	43
4-9	Side View of Configuration of Pipeline Sublength Caused by Buoyancy Forces	44
4-10	Buoyant Tower Showing Cable and Anchor Terminology	53
4-11	Buoyant Tower Showing Lumping Stations, Reactions and Configurations When Reactions Are Not True	54

<u>Figure</u>	Page
4-12 General Surface Current Pattern in Mediterranean Sea	63
4-13 An Example of a Current Meter Record . . .	65
4-14 Quantitative Model of Maximum Current Profile Along Pipeline Route	69
4-15 A Simple Harmonic Progressive Wave	84
4-16 Example Pressure and Buoyancy Profile Along Pipeline	92
4-17 Geometry of Buoyant Tower and Possible Close Pairing of Towers	100
4-18 Buoyant Tower Under Current Force and Pipe Loading	108

LIST OF TABLES

<u>Table</u>		<u>Page</u>
I	Component Sizes, Important Dimensions and Forces Acting for Three Selected Pipeline Systems. Plus Maximum Stresses and Motions of Towers and Pipeline	111 & 112
II	Estimated Investment Required for Pipelines of Three Different Capacities . .	123
III	Estimated Maintenance and Inspection Costs	126
IV	Estimated Return on Investment For Varying Pipeline Life and Gas Selling Price	130

1. INTRODUCTION

Since 1945 there has been world wide industrial growth at an unprecedented rate with an attendant increase in the consumption of energy. Most of this energy has come from fossil fuels: coal, oil and natural gas, with oil and natural gas growing in importance until they provided slightly more than 50% of the world's energy consumption in 1967 (5). The recorded production of oil and natural gas in noncommunist countries increased 250% from 1950 to 1965 and is expected to increase by almost 50% again by 1975 (2).

The centers of greatest growth in energy consumption have been in Europe and Japan which have both been energy-poor and heavily dependent upon imports of crude oil or liquified gas via tanker transport. By 1964 the six Common Market countries were able to provide only 57% of their total energy from indigenous supplies (4). Even with the North Sea gas discoveries, Europe must continue to import almost all of its crude oil and Southern Europe its gas in liquified natural gas tankers. By 1970 France is predicted to be importing 53 billion cubic feet of liquified natural gas annually from Libya and Algeria. By 1980 the predicted liquified natural gas imports from North Africa by Spain, Italy and France alone are estimated at 460 billion cubic feet annually, an amount approximately equal to that

presently shipped in the Trans-Canada pipeline. Because these volumes have been predicted at the relatively high liquified natural gas prices with competition mostly from imported crude oil and expensive domestic coal, any reduction in gas prices would act to magnify this market volume prediction.

The fact that Europe looks to North Africa for energy resources is not surprising. Algeria and Libya are estimated to hold about 13% of the world's total natural gas reserves (5), 20% more than the estimates for the North Sea-Netherlands area, the other, nearby, large source of fluid fossil fuel for Europe.

Historically, France and Italy have been the only large users of natural gas in Western Europe because they were the only countries with indigenous supplies. However, the predicted rapid growth of the use of natural gas relative to other fuels in England, the Netherlands and Germany due to the availability of North Sea gas (3) shows the market acceptance of gas if it is available. England which used essentially no natural gas in 1950 is predicted to be the largest natural gas consumer in Europe by 1980. In the United States, 30% of the total energy consumed is derived from natural gas and it seems reasonable to expect a similarly large gas dependence for Europe which currently derives less than 2% of its needs from natural gas.

For a time it seemed that the U.S.S.R. would be able to gain by supplying a large portion of Western Europe's energy needs and pipelines have been built connecting Russian crude sources with both Austria and Czechoslovakia. However, the recent Russian military moves in Czechoslovakia and other threats to its European neighbors seem to preclude heavy dependence on that source for many years to come. The other possible sources of energy for Europe other than imported fuel in ships are indigenous coal, hydroelectric power and nuclear reactors. The production of coal in Western Europe has not increased substantially since 1955 and the total use of coal has remained fairly constant. Oil and gas are expected to provide 60% of Europe's energy needs by 1980 (4). The latter prediction allows for increases in nuclear and hydroelectric energy sources and a reduction in local production of solid fuels (coal and lignite) which cannot compete in most markets (see Figure 1-1). It is therefore evident that Europe must increasingly rely upon imported oil and gas to supply its energy needs and these imports must come by surface ship unless new marine transportation methods are developed.

The rapid increase in demand for imported fluid fuel in Europe and world-wide has been reflected in a rapid increase in the size of tankers from 16,800 d.w. tons for the T2 types constructed by the United States in 1943-45 to

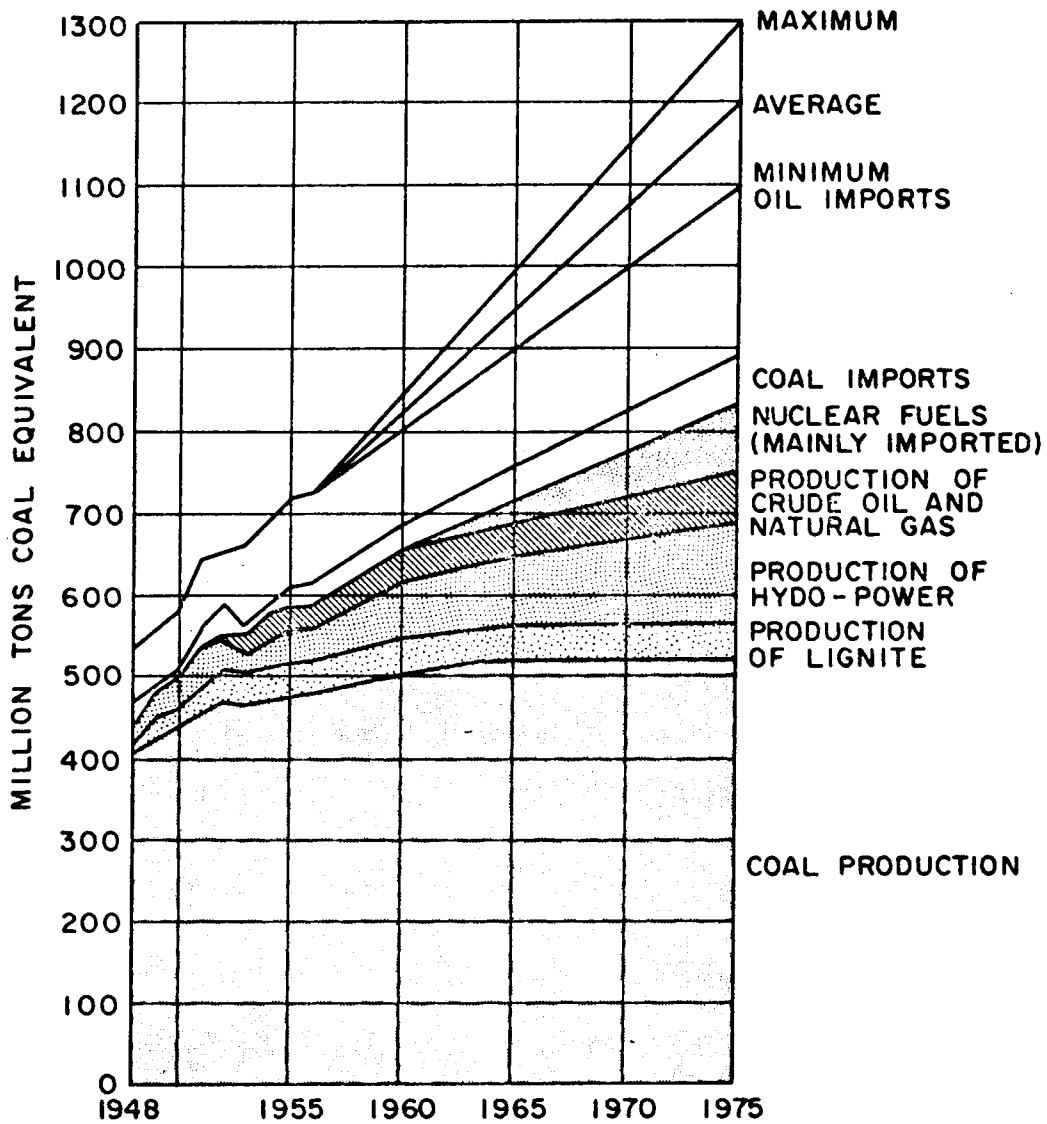

Source: Jensen (4)

Figure 1-1: Past, Present and Projected Sources of Energy Consumed in Western Europe

326,000 d.w. tons for Gulf Oil's "Universal Ireland" built in 1969. Improvements in cargo handling systems, power plants, etc. have permitted an increase in cargo capacity per crewman from 500 tons to 5,000 tons, a six-to-ten fold increase in discharge rates and an increase in ship speed (1). Even larger tankers, constructed in Japan, will be put into service in 1971.

While the shipping of petroleum products by tanker has become highly efficient with the growth in tanker size, these efficiencies are now being seriously questioned. The loss of the 60,000 ton TORREY CANYON in 1967 showed that the giant tanker is a large insurance hazard. The Santa Barbara channel oil leak with its attendant publicity of pollution hazards has sensitized public opinion to the possibility of damage to coastline and wild life. The first Canadian public reaction to the successful voyage of the tanker MANHATTAN through the Northwest Passage was to seek control over possible pollution and to raise questions about the advisability of risking an ice-crushed tanker spilling its cargo. Equally detracting is the fact that the newest tankers are too large to enter most of the world's harbors and require special docking facilities offshore.

It therefore seems timely to consider alternative methods of transporting the ever larger volumes of fossil fuel energy resources which are predicted to be needed by

the world's industrializing communities. This dissertation advances the use of a buoyant, submerged and anchored pipeline as an alternative to surface ship transportation and uses the specific application of crossing the Mediterranean Sea to serve markets in Southern Europe with North African natural gas to test the feasibility of this design concept.

There is also a second and more general possible application of the floating pipeline concept, i.e., the gathering of offshore production from deep-water producing areas. There have been indications from recent exploration holes drilled by the National Science Foundation in water depths exceeding 10,000 feet that oil resources may exist beneath even the deepest ocean floors (8). Means must be developed for bringing any such deep-water oil or natural gas to shore if these resources are to be utilized. As oil companies are already leasing offshore properties in water depths exceeding 1,000 feet, the need for such a gathering system is already immediate.

The primary defense for the floating pipeline approach as opposed to existing methods is that the jobs for which it is being designed and analyzed are not now being done. In the case of the Southern European natural gas market, the oil industry either is searching for gas on the North Shore of the Mediterranean to meet the needs or is content to offer liquified natural gas that is too expensive or short in supply to compete with other fuels for most markets.

Building or maintaining bottom mounted pipelines for moving natural gas through water depths exceeding 1,000 feet is beyond the state of present technology (6) (7). A submarine pipeline to serve Southern Europe with North African gas was considered as early as 1960 (4), but has not been seriously proposed because of the technical difficulties. Similarly no petroleum or gas is produced from offshore well depths exceeding 500 feet, in part because no satisfactory well completion methods have been proven for such depths, but also because no means exist for handling the production from these water depths. Establishing on-site storage for wells producing far at sea and regularly transferring this storage to tanker ships (for oil) may be possible, but seems to offer as many engineering uncertainties as a buoyant pipeline approach while still requiring ships as part of the system. In fact, the only systems presently operating at depths exceeding 500 feet are submarine communication cables, antisubmarine or scientific expendable instrumentation, and military or research submarines.

Viewing this apparent gap in the state-of-the-art in marine pipeline transportation in the light of the documented economic forces in Western Europe acting to provide a growth market for natural gas in that area makes it logical to evaluate a floating gas pipeline system in the context of the real-world application of crossing the

Mediterranean from North Africa to Southern Europe.

2. STATEMENT OF THE PROBLEM

The purpose of this research has been to design, technically analyze and make a preliminary economic analysis of the feasibility of transporting natural gas across a water body in a buoyant pipeline. The pipeline is to be anchored beneath the surface at sufficient depth to avoid surface-generated forces, and, in such a fashion as to restrain its motion due to currents. The crossing of the Mediterranean from Algeria to markets in Southern Europe has been selected as the test case for analysis because of the history of interest in a trans-Mediterranean pipeline, and the forecasts made for energy demand, in general, and natural gas demand, in particular, for Southern Europe.

This problem is one of engineering design using the full scope of the definitions of engineering and design to mean:

1. The isolation and definition of a technically and economically feasible and socially desirable need that is not being met by existing technical-economic systems.
2. Rational defense of the assumption that this defined need has a low probability of being met by proven operational methods in the technical-economic area selected.

3. The delineation of a new approach for meeting the defined need requiring significant engineering innovation in order to have a high probability of success.
4. The technical and economic analysis of the proposed approach using the highest-order methods necessary to reach a firm conclusion that the feasibility of the approach, positive or negative, that will withstand the review of knowledgeable men representing the significant scientific and practical aspects involved. In order to do such an analysis, it is necessary to first create a prototype or feasibility design of the concept involved in sufficient detail so its analysis is representative of the real system that is actually being proposed. It follows that: a) the design model, be it mathematical or physical, must be a faithful representation of the real thing in that it is based upon assumptions related to the "real world" environment, and also represents something that can be accomplished within the state of the technology that now exists, and b) the design model is such that the economic analysis based upon it will be representative of actual costs if the full scale system is built.

5. Finally, for a fully successful effort in engineering design the solution should be accepted by the technical-economic field for which it was conceived, and be built and used.

This research program takes the position that the first two engineering design steps were completed and documented in the INTRODUCTION and concentrates on delineation of the pipeline approach and its technical and economic analysis in sufficient detail to offer a sound basis for deciding its practical use in subsequent sections.

3. LITERATURE AND INDUSTRIAL SURVEY

Oceanographers have long sought a fixed structural base extending from the bottom to the surface of the deep ocean from which they could measure currents, temperatures, sound velocity and other ocean parameters with the same fixed reference provided by piers or towers in shallow water. Cables hung from ships and surface buoys anchored to the bottom by rope or steel cable were the first efforts to provide such instrument bases. In 1951, Kullenberg (13) made the first extensive analytical effort to determine the changing shape (and therefore motion) of cables towed by ships. He showed the shape to be a distorted catenary. Ten years later, Pode (21) extended Kullenberg's work to provide a more general numerical solution with tables that could be applied to cable shapes related to buoy and anchor lines acted upon by ocean currents as well as towed cables. Both Kullenberg (13) and Pode (21) dealt with the case of negatively buoyant cables subjected to the distorting forces of both weight and current, but always with the two dimensional case. Forces and the cable were considered in the same plane.

Independent of Pode's work, Horton (10) devised an approximate method for analyzing the long period motions of a submerged singlewire moored buoy. The buoys he helped design were installed by Johnson and Savage (10) and used

to reference a floating, unmoored drilling ship which drilled holes in the bottom in 11,000 feet of water holding itself in one position with omni-directional propellers (10). This work, part of Project Mohole, Phase I, was the first effort to use large (4,000 lb. displacement) subsurface floats to perform an engineering task in the deep ocean.

In 1963, Aldredge and Fitz (9) constructed and tested a multimoored subsurface buoy with three cable legs that were made neutrally buoyant by the addition of equally spaced buoyant balls along the cable for the purpose of removing the weight induced catenaries and stiffening the system. This trimoored buoy was used for magnetometer work. Analysis of the data showed the structure to be free of short period vibrations. However, its long period motions were not analyzed or measured, and it was damaged and lost at sea within three weeks of installation.

In 1965, Savage and Hersey (20) of the Woods Hole Oceanographic Institution completed an analysis of the motion of a trimoored subsurface buoy with neutrally buoyant legs subjected to both surface wave and current forces by successfully measuring the long term motion pattern of a full scale system in 2,500 feet of water, 160 miles off the South Carolina coast on the Blake Plateau. The analysis of this system, named Sea Spider (see Figure 3-1), accounted for wave forces using wave spectrum data developed

Figure 3-1: Sea Spider, A Trimooored Buoy with Neutrally Buoyant Steel Legs

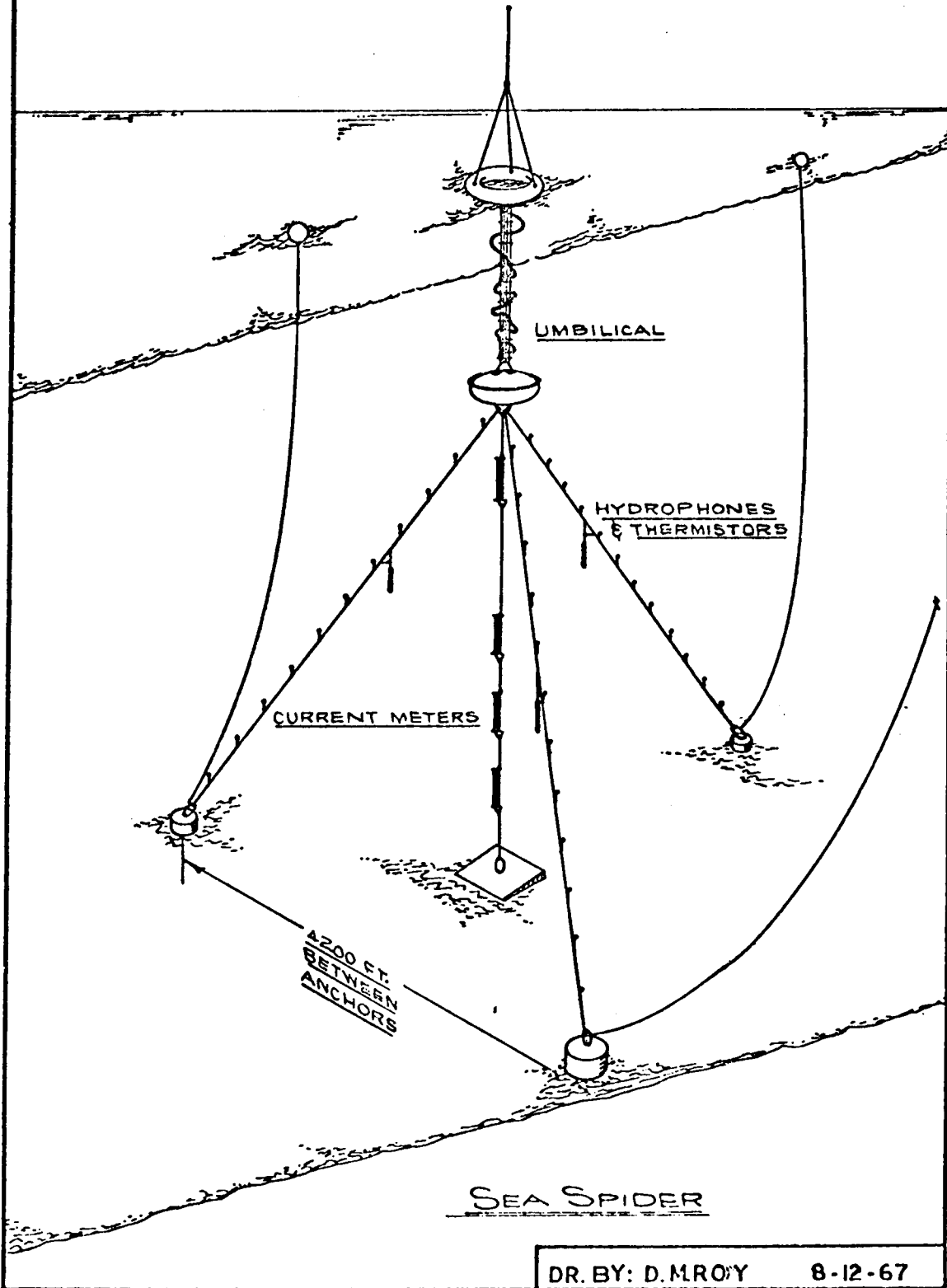

by Moskowitz (17) and methods developed by Milgram (16) and Marks (15) that assume the sea is made up of a summation of simple harmonic waves. The requirements for this system were such that the apex could not move more than a "few feet" for long period motions. It was therefore necessary to minimize the current drag on the system versus the overall buoyancy. Drag coefficients for the main apex buoy were determined by model test using a method developed by Kissenger and Rupp (12). Other drag coefficients were taken from Hoerner (11).

In 1966, Savage, Corell, Blanchard and others (13) reported to the U.S. Navy that it was technically feasible to take saturation diving out of the realm of physiological research at depths down to 300 feet and to use this capability to do "useful work" at those depths. Salvage work and some oil field maintenance work is now routinely done at depths between 200 feet and 300 feet by Westinghouse Corporation, Baltimore, Maryland, Ocean Systems Inc., New York, New York, and other diving companies.

In 1967, Savage and Sniffin (19) extended the original analysis by Savage and Hersey on trimoored buoyant structures to account more completely for motions due to the curvature of the cables caused by current forces. This latter work was done in preparation for the attempted installation of such a hydrostructure, named Sea Spider II in 19,000 feet of water approximately 300 miles north of

Hawaii in September, 1969, by General Motors Corporation, Santa Barbara, California, for the Office of Naval Research. This structure was to have a net buoyancy in excess of 30,000 lbs. The installation of this second Sea Spider-type trimoored structure was not successful due to the accidental activation of one anchor acoustic release after all three cable legs and anchors had been deployed in proper position (See Figure 3-1) at the 19,000 ft. depth. However, the system was completely recovered, and the contractors believe they proved the feasibility of deploying the structure. The Office of Naval Research is proceeding with plans for constructing a similar buoyant structure in 1970 or 1971.

In 1969, Skop and O'Hara (23) and Skop and Kaplan (24) presented a method of determining the motions and cable stressed for a trimoored subsurface buoyant structure using the method of imaginary reactions. This approach offers an improvement over that of Savage and Sniffin (19) because it allows for a varying current versus depth profile and for cable legs made up of multiple diameter cables. As a considerably more general solution than the one by Savage and Sniffin (19), it will be particularly valuable to the designer when more detailed current profile data becomes available for the deep ocean.

Based upon these encouraging experiences and analyses, it has seemed prudent to consider the extension of the work

to date to a possible commercial application, namely a mid-water pipeline to transmit natural gas instead of a buoy for oceanographic research. The pipeline would be maintained by divers using saturation diving techniques. The use of a pipeline to transmit natural gas across the Mediterranean is not a new concept and has been considered in France since gas was discovered in Algeria (4). The literature research evidence supporting the market feasibility of this application of the floating pipeline concept has already been presented in the INTRODUCTION. While it is recognized that all long range market forecasts are only knowledgeable guesses, it is believed that the documented economic forces at work in Southern Europe support the conservative reality of the market predictions.

4. PIPELINE STRUCTURAL ANALYSIS

The proposed pipeline will extend from Phillipeville in Algeria in a straight line 258 miles long to the Island of Minorca where it will be brought to shore to pass through a pumping station and then extend on to the southern coast of France for 250 more miles, underwater, as shown in Figure 4-1. An artistic rendering of the line, underwater, is shown in Figure 4-2. For structural analysis, installation method, and cost analysis purposes the line can be divided into two major categories: 1) that part which will be bottom mounted as the line proceeds outward from shore to deeper water, and 2) that part which will float off the bottom when the water becomes too deep to permit bottom laying with present methods of construction.

The section of the line extending from shore to the maximum depth of submergence of the entire pipeline will be bottom mounted in a fashion identical to present marine pipelines. The solutions to structural and installation problems concerned with this segment of the line are considered state-of-the-art by this study, and will not be considered here. At a depth that is below any significant forces due to surface wave action* the pipeline will be

* This depth is determined from the maximum waves expected in this area as described in Section 4.2.lb.

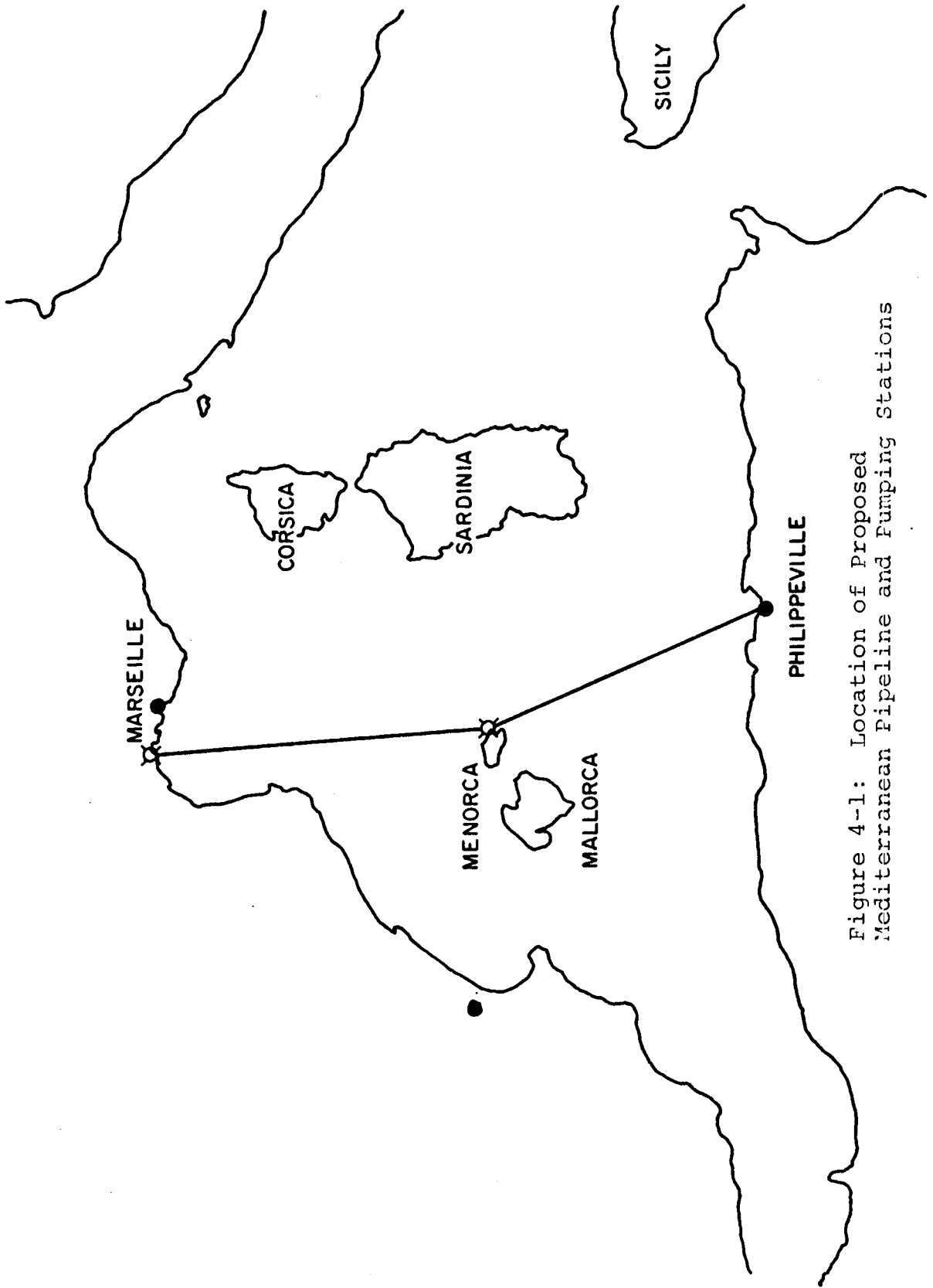

Figure 4-1: Location of Proposed Mediterranean Pipeline and Pumping Stations

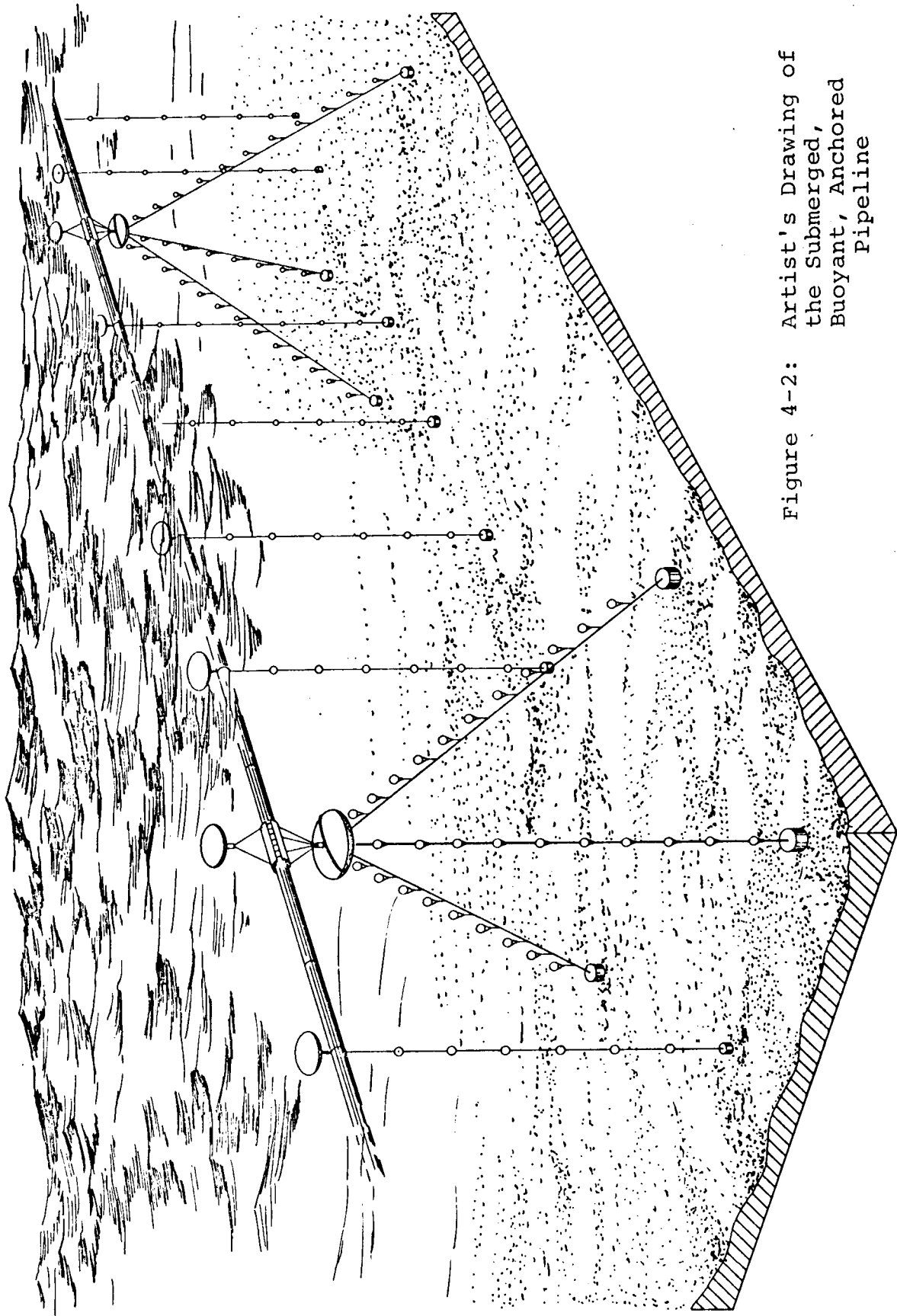

Figure 4-2: Artist's Drawing of the Submerged, Buoyant, Anchored Pipeline

made buoyant and float off the bottom. Where the line passes from the bottom mounted mode to the floating mode is a point of transition requiring special design. It is anticipated that the line will pass out through a truncated cone-like structure to allow distribution of bending stresses that will develop as the line moves back and forth against the fixed point of departure from the bottom under the influence of changing currents (see Figure 4-3). The final design details of this tapered section will depend upon the anticipated forces on the pipe and is also not considered part of this study although the construction and installation costs of this component are included in the section on estimated investment in Chapter 5.

The buoyant, anchored part of the pipeline, submerged at a depth just sufficient to avoid any significant wave forces is shown in schematic form in Figure 4-4. The buoyant line is held down at intervals by a trimoored buoy with steel cable legs made neutrally buoyant by attaching hollow glass spheres at appropriate intervals. Such trimoored buoyant structures, hereafter referred to as the buoyant towers, have been constructed and tested for other purposes as indicated in Chapter 3. In addition to the restraints provided by the buoyant towers, the buoyant pipe is also further restrained in the vertical direction by single anchor cables at intervals between the buoyant tower stations. These single cables must be spaced to

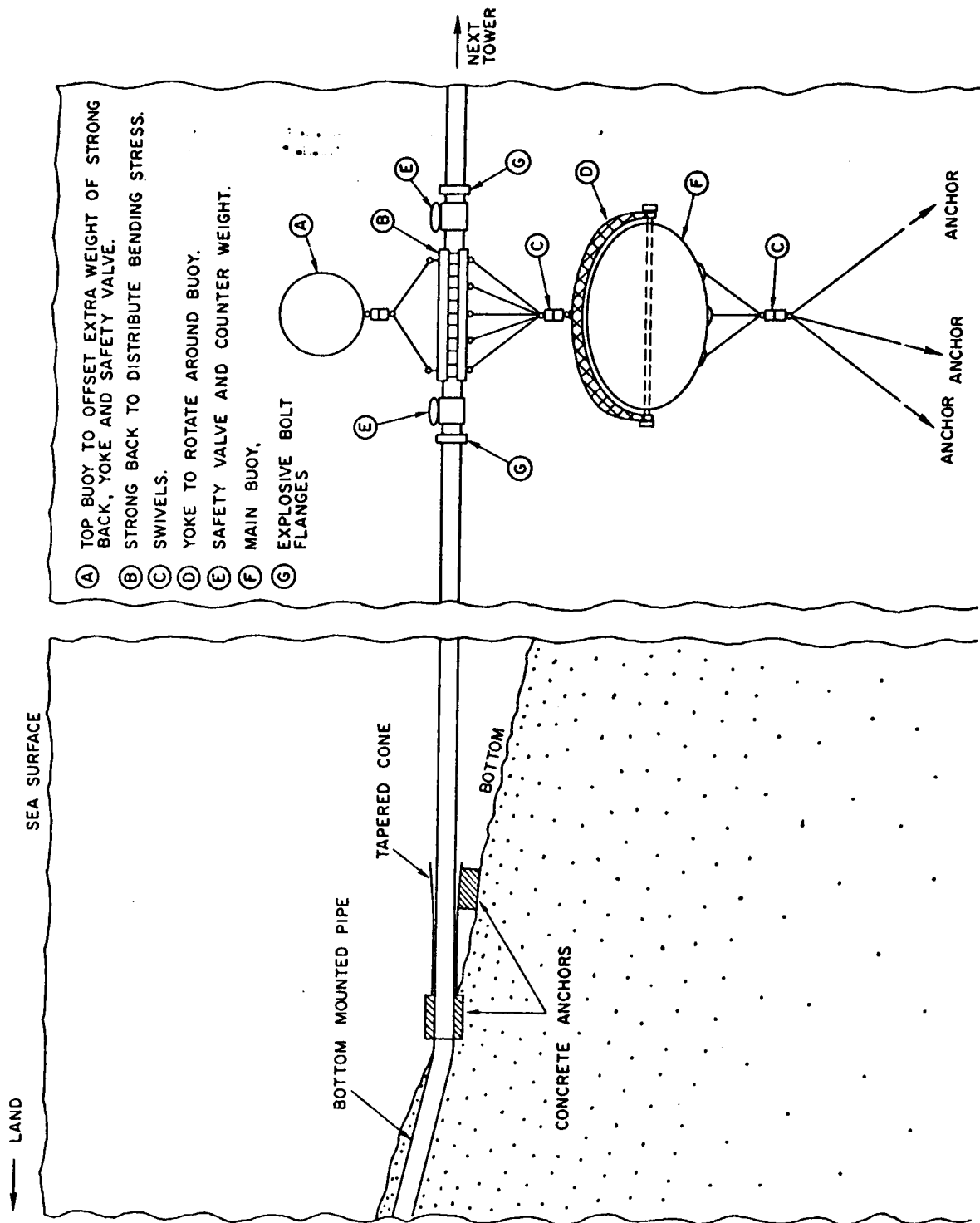

Figure 4-3: Schematic Drawing of Transition From Bottom Mounted to Floating Pipeline with Tower Details

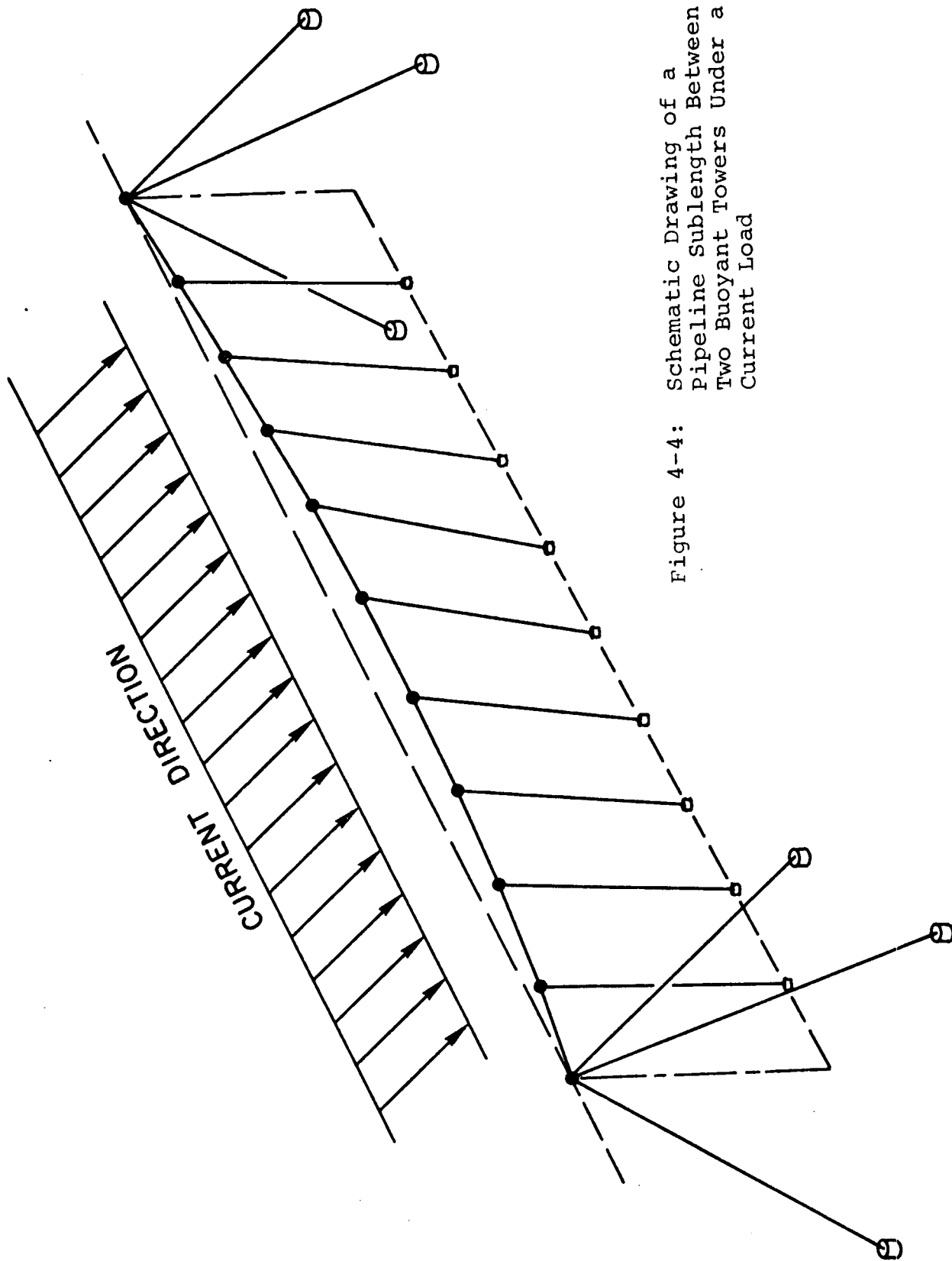

Figure 4-4: Schematic Drawing of a Pipeline Sublength Between Two Buoyant Towers Under a Current Load

prevent the buoyant pipeline from arching too close to the surface* where it would be exposed to significant, cyclic forces due to surface waves or even interfere with the free passage of surface shipping.

The procedure used in this Chapter to make the stress and motion analyses necessary to predict the important cost details of the system for any given pipeline diameter and weight has been as follows:

- The floating pipeline system model has been separated into two parts: 1) the sublength of pipeline between any two buoyant towers together with its several, vertical, anchoring cables, and 2) the buoyant tower anchoring system. (Section 4.1).
- The sublength of pipeline between any two towers is then subjected to ocean current forces and gravity forces and a method for determining the static configuration of the sublength, under load, and its reactions on the buoyant towers is presented. (Section 4.1.1).
- Next, a method for determining the motion of and stresses in the cable legs of the buoyant towers is presented. (Section 4.1.2).
- The forces due to ocean currents, waves and other sources are examined, and the maximum magnitude of

*The specific minimum depth is determined in Section 4.2.1b.

these forces for this Mediterranean pipeline are determined from the available data. (Section 4.2).

- Finally, the maximum ocean and other forces predicted are applied in the methods of analyses developed to determine motions and stresses in the pipeline sub-lengths and towers. A table showing the tower spacing, size of tower buoys, cable sizes, and so forth for the diameters and weights of pipes used in this investigation is presented. The data in this table are developed using optimum pipe sizes determined by Boutin (32) for various volumes of gas throughput. The tower spacing and cable sizes for the various pipe sizes are partially based on the motions and stress analysis methods that have been computerized. The computer programs are shown in Appendix I. Design restraints caused by the practical requirements of construction at sea are shown to be the final criteria for tower spacing. (Section 4.3).

4.1 ANALYTICAL MODEL OF THE FLOATING PIPELINE AND ITS CABLE ANCHORING SYSTEM

4.1.1 The Floating Pipeline Sublength Between Buoyant Towers

In order to separate stresses and motions of a pipeline sublength between towers from the motion of the towers as the ocean forces vary on both the pipeline and the buoyant towers, the following assumptions are made:

- 1) the motion of the apex of any buoyant tower is constrained to be so small relative to the distance between the towers that the end points of the pipe sublength between towers can be assumed to be fixed in space.
- 2) the pipe is attached to the buoyant tower in such a fashion (see schematic Figure 4-3) that the pipe causes only simple reaction forces on the tower apex and no moments. There will be stresses due to bending in addition to tensile forces in the pipe sublength in the vicinity of the attachment of the pipe to the fixed tower when external forces are applied.*

These assumptions result in a model of the buoyant pipeline sublength as shown in Figure 4-5. This Figure shows the external reactions on the pipeline at the two fixed tower ends, the forces acting due to the intermediate vertical cables and the external distributed force components caused by

* The bending stresses will require special design of the attachment of the pipe to the towers and probable reinforcement of the pipe in the vicinity of the attachment to achieve more uniform stress distribution.

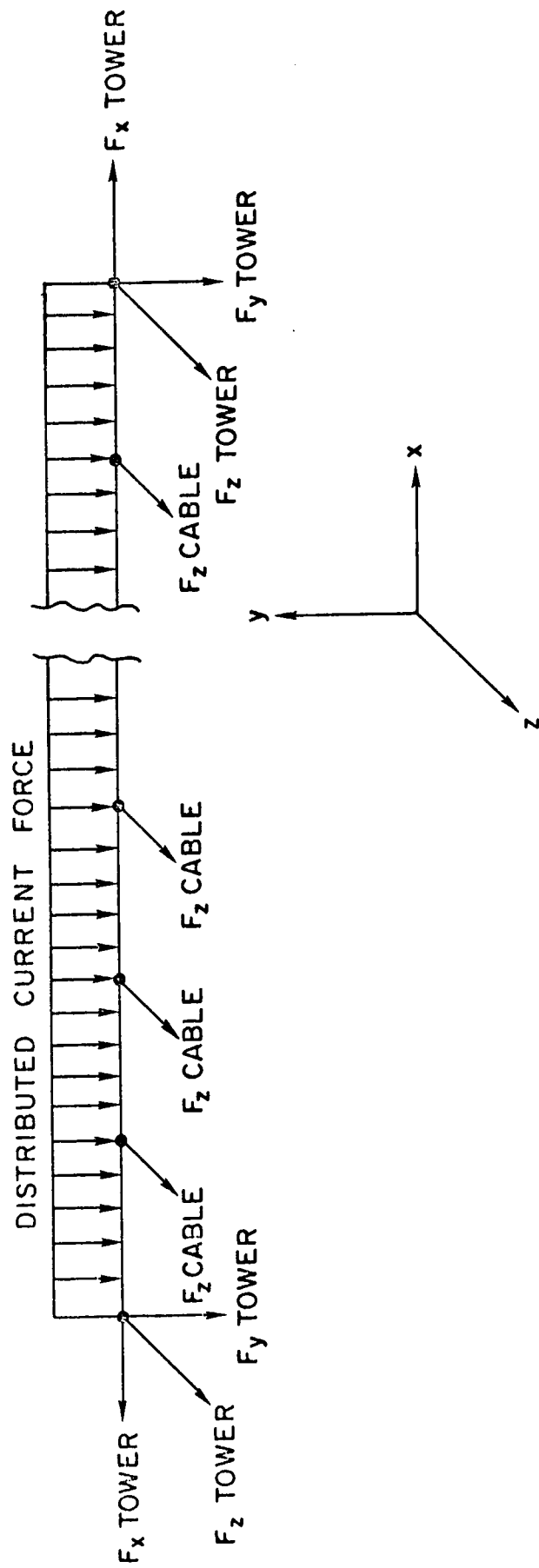

Figure 4-5: Plan View of a Pipeline Sublength Subjected to Current Distributed Load and Cable Forces

ocean current drag forces on the pipe and the pipe buoyancy. Further assumptions to make this model sublength of the pipeline a general analytical model for any sublength in the pipeline are:

- 3) The line formed by the apexes of the buoyant towers between one land point and another will be a straight horizontal line.
- 4) The current, and buoyancy forces acting per unit length of pipeline will be considered constant and uniform for the sublength at any given depth below the ocean surface.*
- 5) The maximum forces acting upon one sublength of the pipeline due to currents, wave action and buoyancy will be the same as the forces acting on the immediately preceding and succeeding sections, and these maximum forces will all occur simultaneously. This, of course, is a remote possibility considering the variations in the physical oceanographic parameters, but it provides the worst case for determination of the pipe motion and stresses and the pipe reactions on the towers if the pipeline is cut.
- 6) The bending stresses in the pipe will all occur in

* The validity of this assumption in the light of the actual current and buoyancy forces will be verified in Sections 4.2 and 4.3 of this Chapter.

the pipe segments attached to the towers where Figure 4-3 shows provisions will be made for a reinforced section or strongback for distributing these stresses over a section of pipe 40 ft. long (one joint). The ends of such terminal joints are designated as Station 1 and Station N in Figure 4-6. Between these stations it will be assumed the pipe is completely flexible with zero moments acting, i.e., in pure tension.

- 7) No part of the pipeline will be permitted to rise towards the surface to a point where the pipeline is subjected to current and wave forces that are so different from those that exist for the fixed ends of the line that the assumption of constant and equal external forces per unit length acting on the pipeline becomes invalid. This assumption has been made for the very practical reason that the tops of the towers will already be placed as close to the surface as possible for the given wave forces, current forces and pipe stresses. Any significant addition to the forces on the pipe, over and above those anticipated for the tops of the towers, will naturally result in pipe reactions that exceed the design limits. In other words, the whole purpose of the design concept is to keep the entire structure just below the strong surface

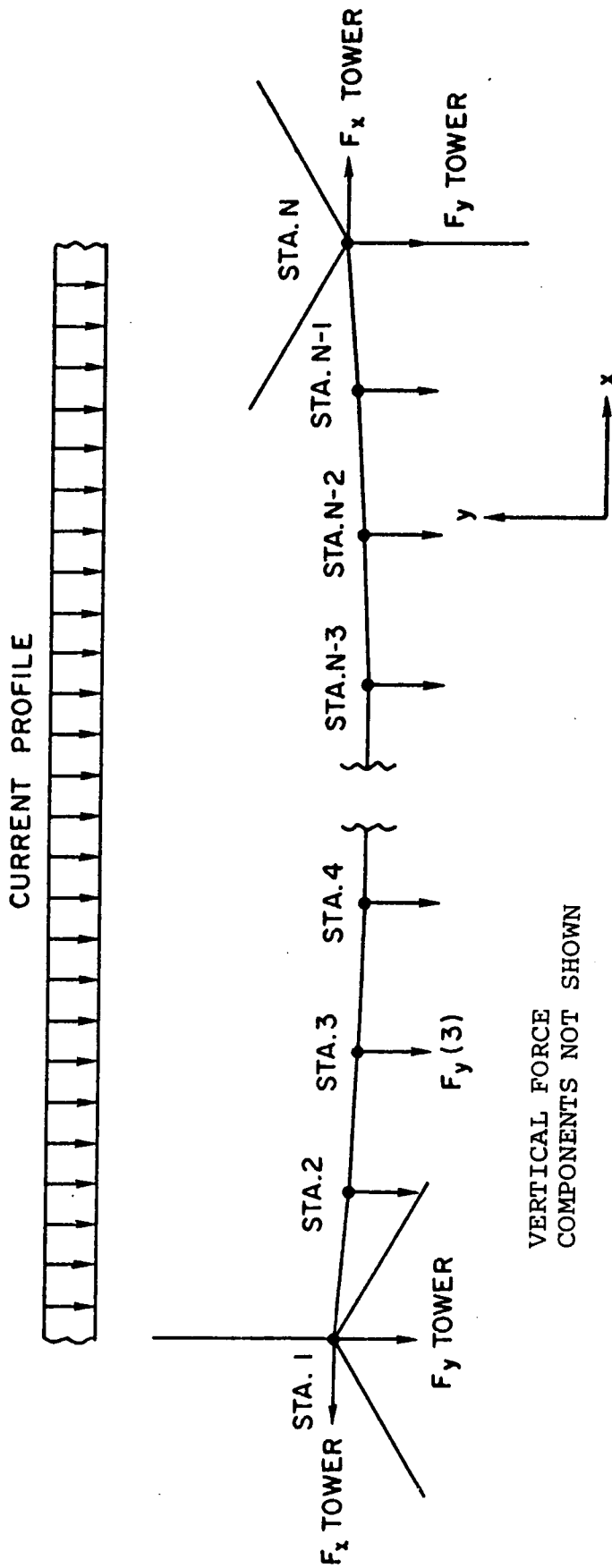

VERTICAL FORCE
COMPONENTS NOT SHOWN

Figure 4-6: Plan View of a Pipeline Sublength
Showing Lumping Stations and
Lumped Forces

effects and surface currents, but still as close as possible to the surface for easier construction, maintenance and repair. Therefore, it will be arbitrarily assumed from the beginning that no part of the pipe can be permitted to rise more than 50 ft. above the level that the apex of either of the two towers would assume if no pipe reaction were acting upon them except the pipe's buoyant force.

- 8) The single, vertical cables used to restrain the vertical arching of the pipe sublength caused by buoyancy forces will be made neutrally buoyant; therefore they will have only the pipe vertical loading for tensions at all times, providing the pipe's horizontal motion is held small compared to the depth. For instance for a depth of 10,000 ft. the top end of a single vertical wire can move ± 300 ft. in the horizontal plane and its distance from the surface will vary less than 10 ft. The horizontal motion of the pipe must be kept small because the pipe must be fixed on charts as a navigation hazard, the assumption will be that it is possible to have constant tension, single-wire, vertical restraints on the pipe at intervals between towers providing the tension in the vertical wire is large compared to the current

forces acting on this wire. The forces at the attachment points of these wires to the pipe must also be distributed by a stiffened section as for the towers. A buoyant element must also be added at these connection points to offset the weight of the stiffened section, and the assumption will be made again that the moments are local to the connection section only and do not affect the pipe shape between restraints.

4.1.1a Determination of the Static Configuration and Tower Reactions for a Pipeline Sublength

The technique used for these determinations is "The Method of Imaginary Reactions" described by Skop and O'Hara (23), and applied by them to cable systems. With the foregoing assumption that the pipe sublength is in pure tension, it can be treated as a large flexible cable also. The Method of Imaginary Reactions is an extension of the classical method of consistent deformation, used by structural engineers to calculate redundant reactions in complex linear structures, to the new linear problem of flexible arrays.

A lumped parameter representation of the external forces acting on the pipe sublength is assumed and the bending stiffness is ignored. The lumping of forces is accomplished by dividing the pipe sublength into a definite,

and convenient, number of segments as shown in Figure 4-6. The sum of the distributed forces on the cable half segments on either side of a lumping station is assumed to be acting at that station. The lumping stations are also selected so that all external point forces such as the vertical cables on the pipe sublength are acting exactly at lumping stations. Consequently, each pipe segment between lumping stations is made a straight line. The static equilibrium of configuration of the pipe sublength, subjected to the external forces specified and including the effect of stretching due to tension, can be uniquely determined from formulas that are functions of only the applied forces and the imaginary reactions. By using a logical method of varying the redundants, the guessed reactions at one end of the pipeline sublength, an iteration technique that is guaranteed to converge to the correct reactions and consequently the correct static configuration can be generated. The number of equations to be solved for each iteration does not depend on the number of lumping stations, but only on the number of external redundant reactions. Prescribing a large number of lumping stations to very closely represent the pipeline sublength increases only the number of required arithmetic calculations but not the complexity of the problem.

Description of the Method

Figure 4-7 shows the abbreviated pipeline sublength with lumping stations numbered from 0 to N. By lumping the external forces acting on each segment at the stations, Figure 4-7 shows the following forces and geometry:

- R_{0x}, R_{0y}, R_{0z} = the external reactions in lbs. force of the fixed buoyant tower on the left end of the pipeline sublength
- Point 0 = Location of the fixed left end tower point with coordinates $x(0), y(0), z(0)$.
- $F_{1x}, F_{1y}, F_{1z},$
 $F_{2x}, F_{2y}, F_{2z},$
 $F_{3x}, \dots,$
 F_{Nx}, F_{Ny}, F_{Nz} = Lumped external forces, in lbs. force, acting at each lumping station from number 1 to N. These lumped forces include all the distributed forces acting on the pipe due to current drag and buoyancy plus the forces due to the action of vertical cables when they are applied.
- R_x, R_y, R_z = F_{Nx}, F_{Ny}, F_{Nz} , respectively.
- Point N = Right end of the pipe sublength with coordinates $x(N), y(N), z(N)$. This point will only coincide with

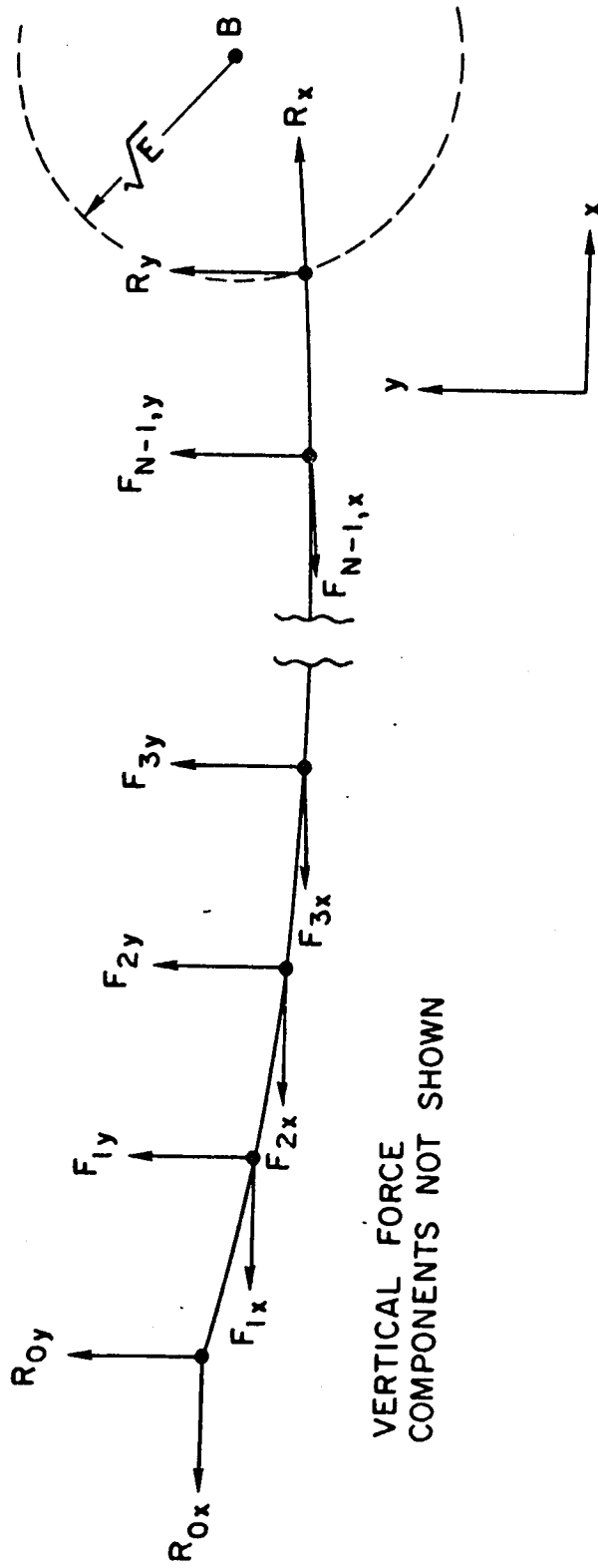

Figure 4-7: Plan View of Pipeline Sublength Model Configuration when External Reactions Are Not Correct

the location of the fixed right side buoyant tower location if R_x, R_y, R_z are the true reaction forces of the tower on the pipeline.

Point B = Location of the right side fixed tower with coordinates a, b, c.

If all the forces F_{1x}, F_{1y}, F_{1z} , are known, then the reaction components R_{Ox}, R_{Oy}, R_{Oz} , at point O can be readily determined; knowing these reaction components, the direction of, tension in, and new length of the segment OA (Segment No. 1) can be found. The position of point A (lumping Station No. 1) with coordinates $x(1), y(1), z(1)$, can be located. Similarly, the positions of stations 2, 3, 4, . . . , N are found by using elementary rules of statics to determine the equivalent reactions at points 1, 2, 3, . . . (N-1). Thus, the equilibrium configuration of the pipe is uniquely determined.

If the point N were actually the position of the second tower point, then, under the action of the lumped external forces, $F_{1x}, F_{1y}, F_{1z}, \dots, F_{Nx}, F_{Ny}, F_{Nz}$ the pipeline segment with two fixed ends would be in equilibrium in the configuration first calculated and the reactions at point N given by R_x, R_y, R_z . On the other hand, if point B is the real position of the second tower

and R_x, R_y, R_z are only initially guessed reactions then they are not of correct value. R_x, R_y, R_z must be corrected by some method to pull N in the direction of B until they coincide within some accuracy limit. Only then will R_x, R_y, R_z satisfactorily represent the true reaction of the right hand tower.

The following procedure is used to obtain a close approximation of the true reaction:

1. The left hand tower position is denoted by

$$x(0), y(0), z(0)$$

2. The position of the n th lumping station is given by

$$x(n), y(n), z(n)$$

when $n = 1, 2, 3, \dots, N$

3. The external force acting at the n th station is given by

$$F_x(n), F_y(n), F_z(n)$$

4. The desired location of the n th station is the right hand fixed tower position given by

$$a, b, c.$$

5. The unstressed length of each segment is given by

$$L_o(n)$$

where $L_o(1)$ is the first segment between the station $x(0), y(0), z(0)$ and $x(1), y(1), z(1)$.

6. Under stress conditions, the length of a segment and tension in it are given by $L(n)$ and $T(n)$, respectively. If all the pipe segments are operated in the elastic range of tension, then

$$L(n) = L_0(n) \left[1 + \frac{L(n)}{B(n)} \right] \quad (4.1)$$

where $B(n)$ is the extensional rigidity of the pipe segment.

7. The resultant force components in the n th pipe segment are given by

$$R_x(n), R_y(n), R_z(n)$$

These resultant force components are related to the external forces acting on the pipe by

$$\left. \begin{aligned} R_x(n) &= F_x(n) + R_x(n+1) \\ R_y(n) &= F_y(n) + R_y(n+1) \\ R_z(n) &= F_z(n) + R_z(n+1) \end{aligned} \right\} \quad (4.2)$$

where: $n = 1, 2, 3, \dots, N-1$;

and

$$\left. \begin{aligned} R_x(N) &= F_x(N) \\ R_y(N) &= F_y(N) \\ R_z(N) &= F_z(N) \end{aligned} \right\} \quad (4.3)$$

when $n = N$. Therefore, whatever $F_x(N)$, $F_y(N)$, $F_z(N)$

are selected will determine the resultant forces in all the other cable segments if the other external forces are constant.

8. The tension in the nth segment is given by

$$T^2(n) = R_x^2(n) + R_y^2(n) + R_z^2(n) \quad (4.4)$$

where $T(n)$ is always positive.

9. The stretched length of each segment can now be determined from equations (4.1) and (4.4). The position of each pipe station is then given by

$$x(n) = \frac{L(n)}{T(n)} R_x(n) + x(n - 1)$$

$$y(n) = \frac{L(n)}{T(n)} R_y(n) + y(n - 1)$$

$$z(n) = \frac{L(n)}{T(n)} R_z(n) + z(n - 1)$$

Therefore for any assumed $F_x(N)$, $F_y(N)$, $F_z(N)$ with the other external forces held constant, the tension and orientation of each pipe segment are uniquely determined. However, for the case of the ends fixed at two towers, $F_x(N)$, $F_y(N)$, $F_z(N)$ are the reactions at the right hand tower and are unknown. Our guesses at their true values will result in the coordinates $x(N)$, $y(N)$, $z(N)$ not being equal to a , b , c , respectively,

the true coordinates of the tower position B in Figure 4-7. Making $x(N)$, $y(N)$, $z(N)$ coincide with a , b , c , respectively, i.e. finding the true reactions is accomplished by an iterative process.

10. When the first guesses at $F_x(N)$, $F_y(N)$, $F_z(N)$ have been made, they result in values for $x(N)$, $y(N)$, $z(N)$ which differ from a , b , c by some length and direction. The measure of the error of the calculated end position, $x(N)$, $y(N)$, $z(N)$ from the desired position, a , b , c is defined by the error function:

$$E = (a-x(N))^2 + (b-y(N))^2 + (c-z(N))^2 \quad (4.5)$$

The Method of Imaginary Reactions (23) then states that, "If the iteration procedure determined by the substitutions:

$$F'_x(N) = F_x(N) + \Delta F_x(N)$$

$$F'_y(N) = F_y(N) + \Delta F_y(N)$$

$$F'_z(N) = F_z(N) + \Delta F_z(N)$$

is followed where:

$$\left. \begin{aligned}
 \Delta F_x(N) &= \frac{\delta}{\sqrt{E}} (a-x(N)) \\
 \Delta F_y(N) &= \frac{\delta}{\sqrt{E}} (b-y(N)) \\
 \Delta F_z(N) &= \frac{\delta}{\sqrt{E}} (c-z(N))
 \end{aligned} \right\} \quad (4.6)$$

and where δ is a positive number chosen at each iteration so that $E' < E$, then after a large enough number of iterations $E \rightarrow 0$ arbitrarily closely and the static equilibrium position of the pipe is obtained."

This technique has been used in this study to determine the static equilibrium position and tensions in the pipeline sublength under external loading from ocean forces, buoyancy and cable restraints. It is recognized that the assumption of no bending stresses in the pipe except directly adjacent to the tower connection is a questionable simplification. Large diameter, thick walled pipes will be very stiff and neglecting the bending stresses in the analysis will exaggerate the arching of the pipe due to buoyancy and currents. Therefore, the motion of the pipe will be less than that predicted by the model. It is therefore a practical model for determining the maximum motions of the pipe under the external loads and

restraints. It is also a useful model for determining the loads placed by the pipeline sublength on the buoyant towers.

On the other hand, neglecting the stiffness of the pipe and the movements will present incorrectly small magnitudes for internal stresses developed in the pipe walls.

4.1.1b The Stresses in a Pipeline Sublength

"The stress analysis of a pipe or cylindrical tank supported at intervals on saddles or pedestals and filled or partly filled with liquid is difficult, and the results are rendered uncertain by doubtful boundary conditions." This statement by Roark (26) sums up the difficulty of determining the true stress in a pipeline sublength. It is possible only to bound the stresses using equations of statics from shell theory.

The pipeline sublength has two significant stress configurations which are shown in Figure 4-8 and Figure 4-9. Figure 4-8 shows a pipeline sublength in plan view with the uniformly distributed load due to current drag acting on the pipe suspended between two towers. The vertical cables that restrain the pipe buoyant forces have no restraining effect on the pipeline configuration in this view. The model is therefore the same as that for a long beam with each end imbedded in a wall since the next pipe sublength on

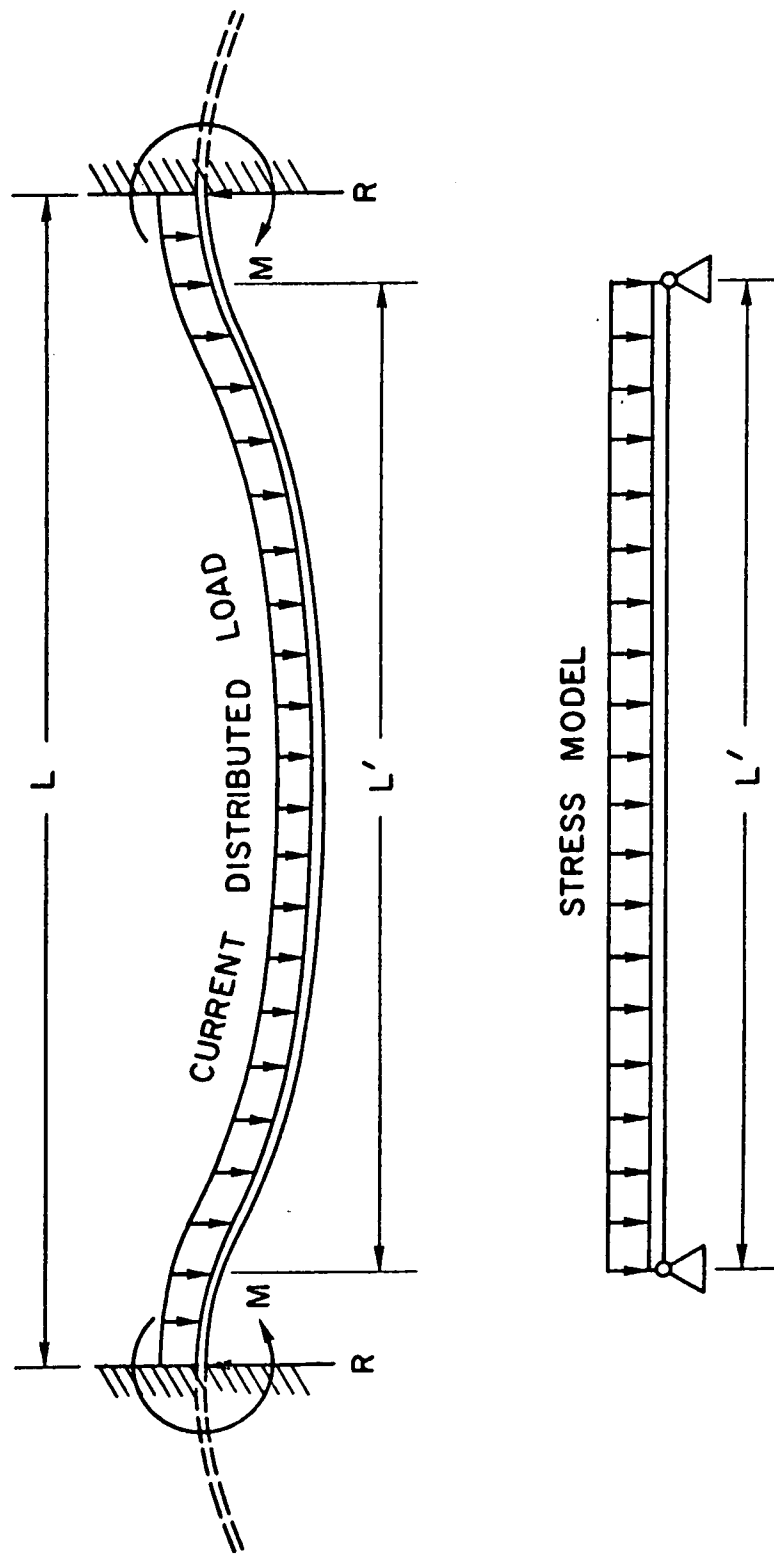

Figure 4-8: Plan View of Configuration of Pipeline Sublength Caused by Current Forces

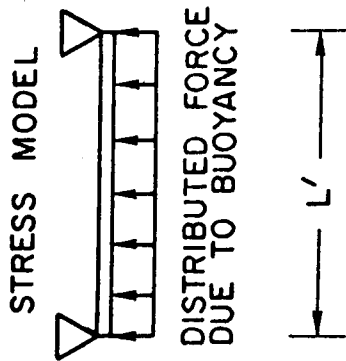
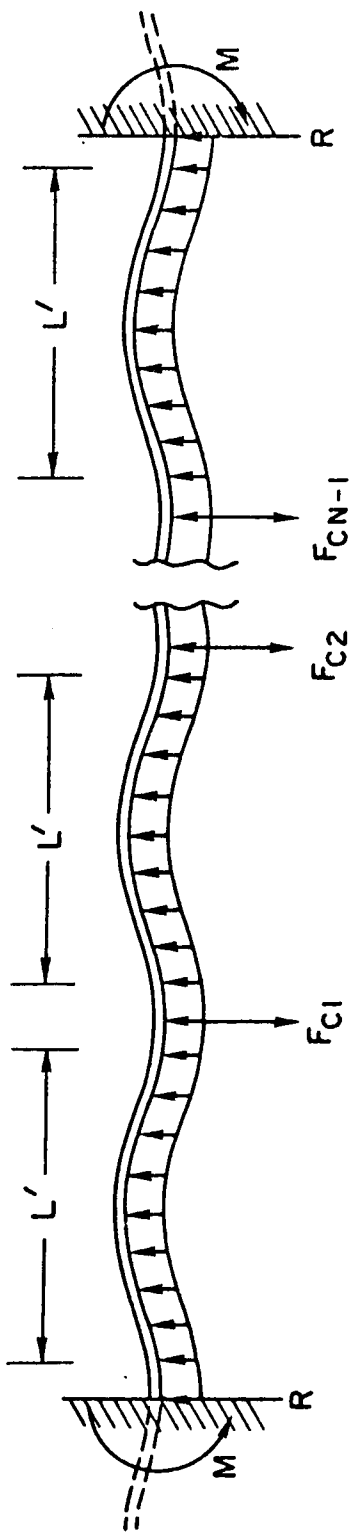

Figure 4-9: Side View of Configuration of Pipeline Sublength Caused by Buoyancy Forces

each end exerts a moment and reaction on the pipe sublength in question.

An analysis of the stresses in such a long pipe span, so supported, has not been found in the literature and presents a significant problem in itself. However, for the purpose of this investigation, the magnitude of the stresses involved can be usefully approximated by treating the length L' in Figure 4-8 as a long span held at the ends and subjected to a uniform, distributed load. Since L' spans the two inflection points of the pipe, this is a reasonable approximation of the boundary conditions that exist.

Pfluger (27) has developed a formula for the stresses in a pipe in such a condition

$$N_s = P_E \left[\frac{\ell^2}{6r} - \frac{ur}{r} - \frac{s}{r} (\ell - s) \right] \sin \phi \quad (4.7)$$

where: N_s = unit normal force on the axial direction in lb_f/ft

P_E = weight of the pipe shell per unit of mean diameter surface in lbs/ft^2

s = distance from left hand end in ft to the cross section of pipe in question

ℓ = the length between the fixed ends in ft
= L' in this case

r = the mean radius of the pipe in ft

u = Poisson's ratio = approximately 0.32 for steel pipe

ϕ = the angle of rotation of a radius vector in the plane of the pipe cross section.

Maximum tensile stresses occur when $\phi = 90^\circ$.

An example will indicate the stresses created by the current forces acting on the pipe.

Consider a pipe sublength that has $L = 10,000$ ft between the towers. If the point of inflection is 500' from each tower, then $L' = 9000$ ft. Let the pipe dimensions be: mean diameter $r = 36$ ", wall thickness = 1", and length $L' = 9000$ ft. Treating the two dimensional problems of Figure 4-8, assume the current drag force per ft on the pipe is a constant 0.5 lbs/ft. In this problem there is no gravity dimension, but the constant drag force can be viewed as an equivalent weight to substitute in the equation 4.7.

$$P_E = 0.5/\pi(3) = .053 \text{ lbs/ft of radius}$$

Taking $\phi = 90^\circ$ in equation (4.7) to get the maximum unit normal force gives:

$$N_s = .054 \left(\frac{9000^2}{6(3)} - .3(3) - 0/3 (6000-0) \right) \quad (1)$$

$$N_s = 240,000 \text{ lbs/ft of radius}$$

$$N_s = 20,000 \text{ lbs/inch of radius}$$

In other words the maximum stresses introduced in the example pipe sublength, L' , due to the current load are of the order of 20,000 psi tension. Of course the stresses in the pipe where it is bent past a tower will be larger than this, but, as mentioned earlier, a thickened, tapered section(s) will be provided here to accept the added stress. Added to these tensile stresses caused by current loads will be those due to the internal gas pressure in the line which will vary from 1400 psi at one end of the entire line to 700 psi at the other end,* but these will be small (less than 10,000 psi for the example pipe) compared to the tensile strength of the pipe.

The example that has been given presents a realistic picture of the maximum magnitudes of the tensile stresses that will be caused by current loads, once the pipe has been installed, for the following reasons:

- 1) The current maximum velocities expected at the depth the line will be installed will not cause current loads in excess of 0.5 lbs/ft on a 36" diameter pipe.**
- 2) The current forces on a cylinder, for any given current velocity, are directly proportional to the cylinder diameter. Therefore the stresses developed for a 36" diameter cylinder in equation 4.6 are the

* See Section 4.3.

** See Section 4.2

same for any other diameter pipe with the same pipe span, wall thickness and boundary conditions for a constant current velocity.

- 3) The maximum pipe span considered between towers will be 10,000 ft for reasons of installation and handling.*

The other significant stresses to be considered in this design feasibility stress analysis of the pipe sub-length are those caused by the arching of the buoyant pipe between vertical restraints. Figure 4-9(a) shows the two dimensional configuration, boundary conditions and forces acting in this mode of stress. Once again, it will be assumed that the pipe section can be reinforced and tapered at the point of connection to the cable restraint. The added stresses due to bending moments will be assumed accounted for in this fashion at these junctions. The other stresses to be considered are those that will be developed in the free span between inflection points, i.e. the length, L' .

As shown in Figure 4-9(b), the worst case (maximum stress) boundary condition that can be assumed for this segment are a simply supported span. Pfluger (27) has also

* See section 4.3

considered this case

$$N_s = P_E \frac{s}{r} (\ell - s) \sin \phi \quad (4.8)$$

where the symbols are the same as in the previous stress equation 4.7. Using the same example as before of a 36" mean diameter, r , 1" wall thickness pipe, and taking span $l = L' = 1000'$, it is then necessary to assume a value for P_E . As before, P_E represents the gravity force per unit of mean surface area of the pipe in Pfluger's (27) analysis. However, net buoyancy forces are involved in this problem. Assume a constant buoyant force of 10 lbs/ft then

$$P_E = 10/\pi(3) = 1.1 \text{ lbs/ft}$$

and

$$N_s = - 1.1 \frac{500}{3} (1000 - 500) (1) = 92,000 \text{ lbs/ft}$$

This is a stress of only 2600 psi tension on the pipe for a 1000 ft span between restraints. It will be necessary to restrain the pipe at least every 2000 ft in the vertical direction to make it stay at a depth below significant wave forces; therefore the stresses due to the vertical configuration on a 36", 1" wall pipe will not exceed approximately 10,000 psi if the net buoyancy does not exceed 10 lbs/ft.

As will be shown in subsequent sections, 12 lbs/ft of buoyancy will be the maximum allowed for a 36" pipe, i.e., less than 2% of the overall weight of water displaced/ft.

To be sure, this presentation of stress considerations would hardly be suitable for a detailed pipe design. However, the other stresses due to shear and hoop tension are all orders of magnitude smaller than those due to axial tension according to Pfluger (27). It is therefore prudent to conclude that the stress problem can be readily overcome for the pipe spans and loads that will be considered here provided thick walled pipe of the order of one inch is used for all pipe diameters. As will be shown subsequently, the pipe must be weighted to reduce its buoyancy anyway, so this does not present a buoyancy problem.

4.1.2 Motions of and Stresses in the Buoyant Towers

The other major subsystem of the total buoyant, submerged, anchored pipeline is the buoyant tower, patterned after the Sea Spider (Figure 3-1). In the case of these pipeline towers, however, provision must be made to prevent the pipeline from exerting a movement on the apex of the trimoored tower. The suggested method for accomplishing this effect is a yoke around the apex buoys as shown in the schematic drawing in Figure 4-3. Figure 4-3 also shows a second buoy above the pipeline junction with the tower to hold the line above the tower and prevent tangling. These

two buoys at the apex provide the vertical force to put the tower legs in tension. The legs, themselves, are made neutrally buoyant by the attachment of high pressure glass spheres at appropriate intervals along the legs. The towers are anchored to the bottom by dead weight anchors large enough to withstand any vertical lift or horizontal forces predicted for the particular system.

4.1.2a Method of Analysis of Motion and Stresses on the Towers

An analysis of motions of and stresses in towers of this type was first accomplished by Savage and Hersey (20) and Savage and Sniffin (19). However, as stated in Chapter 3, LITERATURE SURVEY, Skop and Kaplan (24) subsequently developed a more general method of determining the static configuration of such towers or cable arrays acted upon by current induced forces. This method uses the Method of Imaginary Reaction already described, combined with a method of successive approximations to determine the configuration of and stresses in a buoyant tower. A description of the method is given in exquisite detail by Skop and Kaplan (24) and will not be repeated here, except for an outline of the major steps involved which are as follows:

- 1) First, two key assumptions are made:
 - a) The current, although it may vary in magnitude as a function of depth, is unidirectional.
 - b) The drag force component which acts in the direction normal to both the stream and the cable is zero.

It is to be noted here that unlike the first analysis method used on the pipeline, the current force acting per unit length of cable is not necessarily constant. In fact, it is permitted to vary as the cable attitude with respect to the current varies even though the current is unidirectional and has a constant velocity at any given depth.

- 2) As before, the buoyant structure is divided into lumps as shown in Figure 4-10.
- 3) There are now three fixed ends to be considered instead of two; therefore one of the anchor locations is designated as primary as shown in Figure 4-11. The other two are called secondary.
- 4) In the analysis method, the two ends that must be attached to the secondary anchors are released from the anchor points while the tower is subjected to current forces, net buoyancy forces, and, in this application of the method, the reactions of the pipeline on the tower as determined by using the method in Section 4.1 of this chapter. Initial guesses are

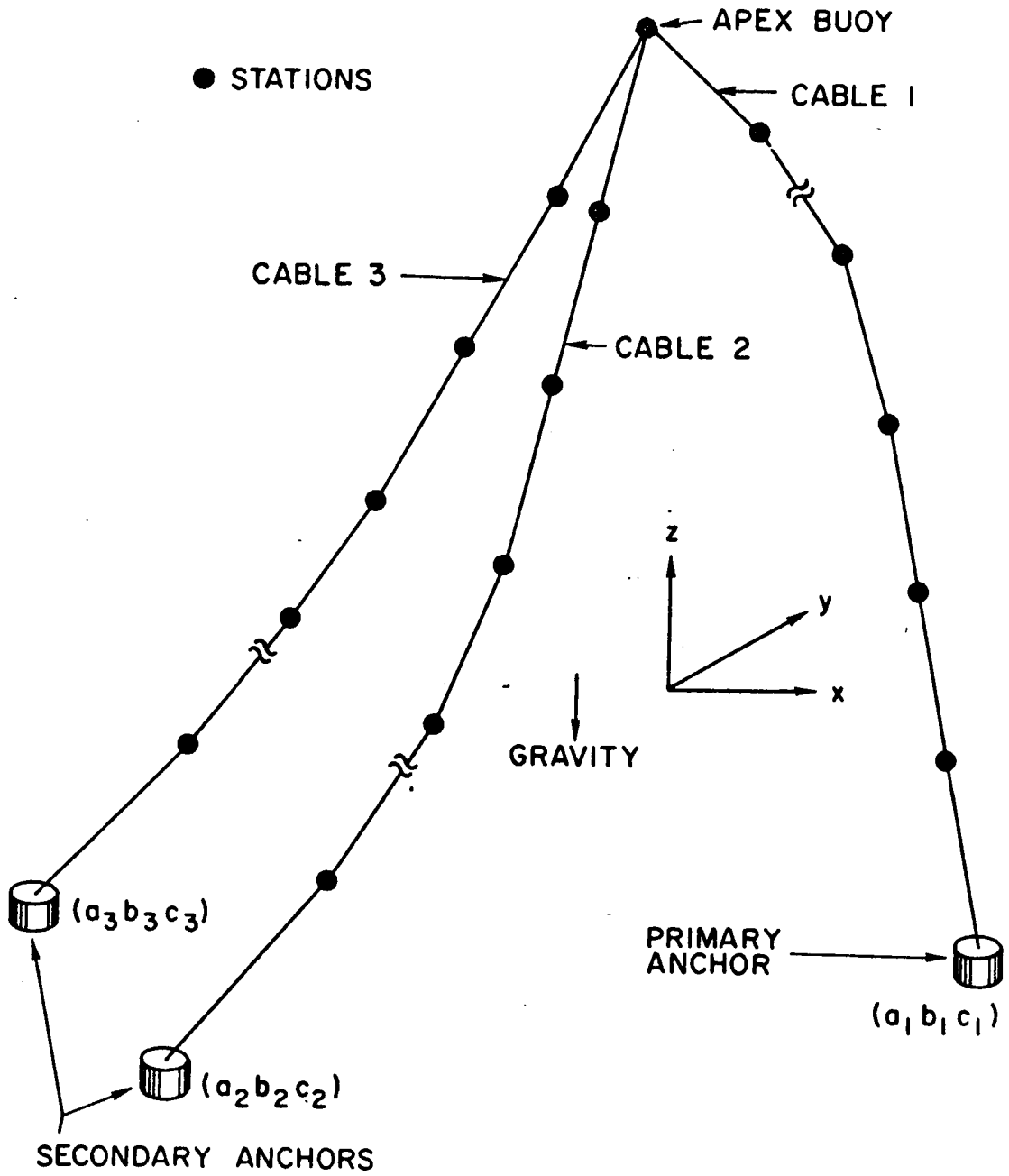
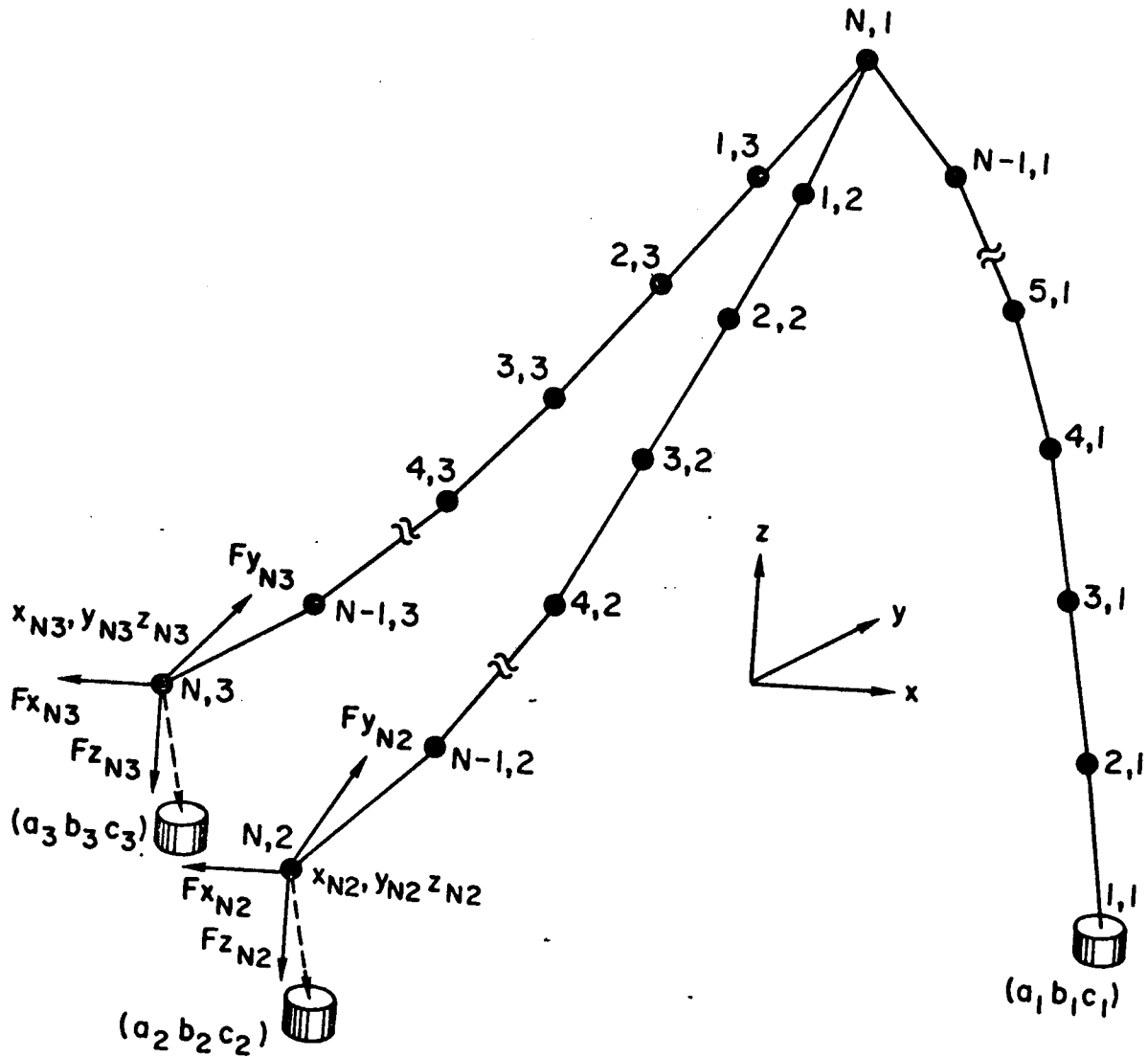

Figure 4-10: Buoyant Tower Showing Cable and Anchor Terminology

Figure 4-11: Buoyant Tower Showing Lumping Stations, Reactions and Configurations When Reactions Are Not True



then made for the three components of reaction that must exist at each secondary cable end to "pull" the cable end to the true anchor position. Using these initial, guessed or imaginary reactions, the configuration of the tower is determined and the "error" between the cable end positions and the true secondary anchor position is determined.

- 5) As opposed to the single pipe system with a single "free" end, there are now two "free" ends with locations that are some "error" distance from their true anchor position. These ends are at locations $x_{N,2}$, $y_{N,2}$, $z_{N,2}$, and $x_{N,3}$, $y_{N,3}$, $z_{N,3}$ as shown in Figure 4-11. The subscripts N,2 and N,3 designate the last lumping station N or the end of the cable on secondary cable number 2 and 3, respectively. The lumping station locations on cable 2, for example, vary from $x_{1,2}$, $y_{1,2}$, $z_{1,2}$ at the branch point (apex buoy location) to $x_{n,2}$, $y_{n,2}$, $z_{n,2}$ where $n = 1, 2, 3, \dots, N$. The cable lumping stations are numbered from 1 at the branch point to N at the anchoring ends for the secondary cables, 2 and 3. The reverse is true for the primary cable numbered 1. Therefore, in the subscript system used:

$$x_{1,2}, y_{1,2}, z_{1,2} = x_{N,1}, y_{N,1}, z_{N,1} =$$

$$x_{1,3}, y_{1,3}, z_{1,3} = x_{N,1}, y_{N,1}, z_{N,1}$$

Also, the positive measure of error E defined previously for this method now becomes the sum of the two errors

$$E = (x_{N,2} - a_2)^2 + (y_{N,2} - b_2)^2 + (z_{N,2} - c_2)^2 \\ + (x_{N,3} - a_3)^2 + (y_{N,3} - b_3)^2 + (z_{N,3} - c_3)^2$$

- 6) As in the single end case, the original reactions guessed for the anchor ends are now corrected by a positive corrective factor

$$\Delta F_{x,N,2} = \frac{\delta}{\sqrt{E}} (a_2 - x_{N,2})$$

$$\Delta F_{y,N,2} = \frac{\delta}{\sqrt{E}} (b_2 - y_{N,2})$$

$$\Delta F_{z,N,2} = \frac{\delta}{\sqrt{E}} (c_2 - z_{N,2})$$

$$\Delta F_{x,N,3} = \frac{\delta}{\sqrt{E}} (a_3 - x_{N,3})$$

$$\Delta F_{y,N,3} = \frac{\delta}{\sqrt{E}} (b_3 - y_{N,3})$$

$$\Delta F_{z,N,3} = \frac{\delta}{\sqrt{E}} (c_3 - z_{N,3})$$

and the new guessed reactions become

$$F'_{x,N,2} = F_{x,N,2} + \Delta F_{x,N,2}$$

$$F'_{y,N,2} = F_{y,N,2} + \Delta F_{y,N,2}$$

$$F'_{z,N,2} = F_{z,N,2} + \Delta F_{z,N,2}$$

$$F'_{x,N,3} = F_{x,N,3} + \Delta F_{z,N,3}$$

$$F'_{y,N,3} = F_{y,N,3} + \Delta F_{y,N,3}$$

$$F'_{z,N,3} = F_{z,N,3} + \Delta F_{z,N,3}$$

- 7) These new forces are then applied to the cable ends, a new static configuration determined, a new Error Function E' found and the process repeated, again and again, until the error, E' is less than some preset, satisfactory magnitude E_c .^{*} When this event occurs then the reactions at the anchor points are considered sufficiently true and

* If at the end of any one iteration the new error measure E' is greater than the previous error E , then δ is too large. It is reduced to $\delta/2$, and the previous iteration repeated. The process is repeated until $E' < E$.

$$x_{N,2}, y_{N,2}, z_{N,2} = a_2, b_2, c_2$$

$$x_{N,3}, y_{N,3}, z_{N,3} = a_3, b_3, c_3$$

within the accuracy desired.

- 8) When the static equilibrium configuration is thus obtained, the imaginary reactions at the lumping stations represent the tensions in the cable segment adjacent to the lumping stations; therefore, the stresses in the cables for a given set of external force conditions are also obtained at the same time.

This method of determining the motions of and stresses in a tower system has been used in a computer program for an IBM 360-67 computer to determine these data for the several pipeline designs evaluated in this study. The program was adopted from one by Skop and Kaplan (24) and is shown in Appendix I.

In addition to the Method of Imaginary Reactions already described, this program uses another important technique to achieve the desired results: It uses a method of successive approximations as well as the Method of Imaginary Reactions. This is necessary because the Method of Imaginary Reactions requires that the applied external forces remain constant from one iteration to the next. The current forces are a function of the cable leg attitude

relative to the current direction,* and the cable segment directions change for every iteration. By combining the method of successive approximation with the Method of Imaginary Reactions, this variable external force can be accounted for in the method. The combined technique (24) "consists of making an initial guess as to the value of the hydrodynamic (current) forces and then using these values while finding the equilibrium position of the tower by Imaginary Reaction. Once this position is found, the hydrodynamic forces are recalculated, and the position of the array under these new forces is then again found by Imaginary Reactions. The iteration technique is continued until the desired degree of accuracy is obtained. A natural measure of accuracy for the successive approximation routine is to compare the equilibrium coordinates of each cable lumping station with their previous values for two successive iterations. If the coordinates differ by less than a preset, fixed amount, E_D , the iteration is considered satisfied; if any coordinate change is greater than E_D , the iteration is continued." In terms of the subscripts used in Figure 4-11, the condition is satisfied when

* Because the current direction is assumed unidirectional regardless of depth or magnitude, the current forces per unit length change every iteration. See Section 4.2.

$x'_{n,m} - x_{n,m}$, $y'_{n,m} - y_{n,m}$, $z'_{n,m} - z_{n,m}$ are all less than E_D for $n = 1, 2, \dots, N$ and $m = 1, 2, 3$ (signifying the tower leg under consideration). Therefore, in the combined technique, the Method of Imaginary Reaction is used to determine the equilibrium shape of the structure within each successive approximation of the hydrodynamic (current) forces. When, in the total iteration process E becomes less than E_C , the cutoff value for the Method of Imaginary Reactions, there is an error, within $\sqrt{E_C}$, from the actual equilibrium coordinates for the coordinates calculated for every cable lumping station. Consequently, it is necessary for the cutoff value E_D for the successive approximation iteration to be larger than the value of this final, acceptable error. Skop and Kaplan define a safe error of $E_D = 10 \sqrt{E_C}$.

Therefore, the methods for determining the motions of, and stresses in the pipeline sublengths and buoyant towers have now been defined. Before proceeding to apply these methods to pipelines of various diameters that are determined by the rates of gas volume required to be pumped, it is first necessary to determine the ocean forces that will be acting on such a submerged, buoyant, anchored pipeline system in the Mediterranean location that has been selected for this design feasibility analysis.

4.2 EXTERNAL FORCE ACTING UPON THE PIPELINE SYSTEM

4.2.1 Non Gravity Forces Acting

The non gravity forces that can act upon the pipeline are of three kinds:

Current forces which refer here to forces resulting from currents caused by ocean circulation and not wind driven surface currents.

Surface effect forces which refer to surface wave-generated forces and wind driven current forces.

Special forces such as impact forces caused by a subsurface ship colliding with the structure or drag forces caused by trawler nets or other fishing lines tangling in the structure.

4.2.1a Current Forces in the Mediterranean Environment

Current forces are due to hydrodynamic drag of the water passing by a body with some velocity.

In the ocean the currents are due to circulation of the water caused by temperature and salinity differentials and interaction with the atmosphere. There are both global and local current patterns, and velocity magnitudes vary from zero to more than five knots depending upon geographical location or depth or both. Currents exceeding one knot are rare in the open ocean (away from shelf areas) except

in major current streams such as the Gulf Stream in the Atlantic or the Cromwell Current in the Pacific.

In the western Mediterranean area under consideration, the major current patterns as viewed at the surface are shown in Figure 4-12. This figure should be viewed like a one year time lapse photo of the sea surface current patterns. Different segments of the current pattern are dominant at different times depending upon the season and atmospheric pressure pattern. However, the general circular pattern along the coast of North Africa, up the western coast of Italy and back to the west along the southern coasts of France and Spain is a continuous phenomena.

The currents vary not only with time and location on the surface, but also with depth. A very simplified model of the overall vertical current circulation would show the Atlantic waters entering the Mediterranean through the Straits of Gibraltar in the upper zone of the water column and spreading eastward still holding to the upper zones. Then, cooled by energy interchange with the atmosphere, the entering water eventually sinks and returns through the Strait to the Atlantic in the lower zone of the water column. These vertical motions of the water vary with the season of the year and are least evident in the summer months.

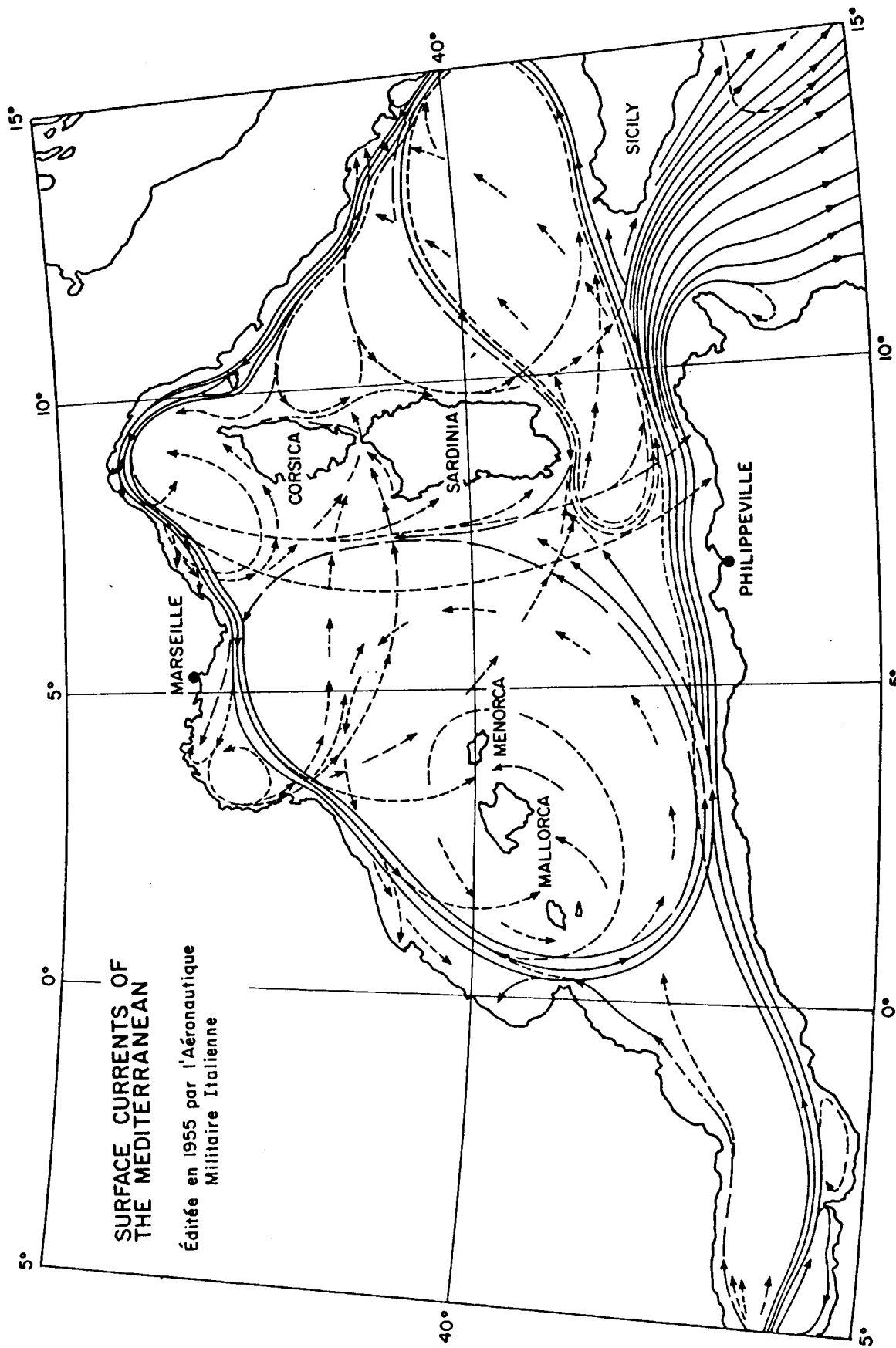

Figure 4-12: General Surface Current Pattern in Mediterranean Sea

For engineering design purposes, however, we are interested in a much more detailed picture of the current velocities than the general circulation models of the meteorologist or oceanographer. We require a model showing the variation of the maximum current magnitudes and their directions with depth of water along the entire length of the pipeline crossing. Such current data can only be obtained at present by strings of several continuously recording current meters, extending from the surface to the bottom and suspended from a buoy. Only a few such recordings have been made in the entire Mediterranean. Miller (28) presented the results from a string of five current meters located at a point approximately 38°N and 5°E in a water depth of about 1500 fathoms during January through March, 1969. La Combe (29) presented the results from a single current meter located at a depth of 10 meters from the Bouee Laboratoire at the location 42°N and $5^{\circ}30'\text{E}$ in a water depth of about 7000 ft. Figure 4-13 shows the results. Gonella, Eskenazi and Fropo (30) reported continuous current measurements taken at a depth of 20 meters at location $42^{\circ}47'\text{N}$ and $7^{\circ}29'\text{E}$ in July, 1964, by Bouee Laboratoire and again in December, 1964, at depths of 25 meters, 100 meters and 300 meters. Measurements with moored current meters were made by Swallow near location 42°N , 5°E in February and March, 1969, and are reported in

MUSEUM NATIONAL D'HISTOIRE NATURELLE
 LABORATOIRE D'OCEANOGRAPHIE PHYSIQUE

BOUÉE LABORATOIRE

TRAJECTOIRE A 10m.

ETABLIE D'APRES LES MESURES DE VITESSES DE COURANT
 DU 2-7-68 A 8h. AU 9-7-68 A 20h.

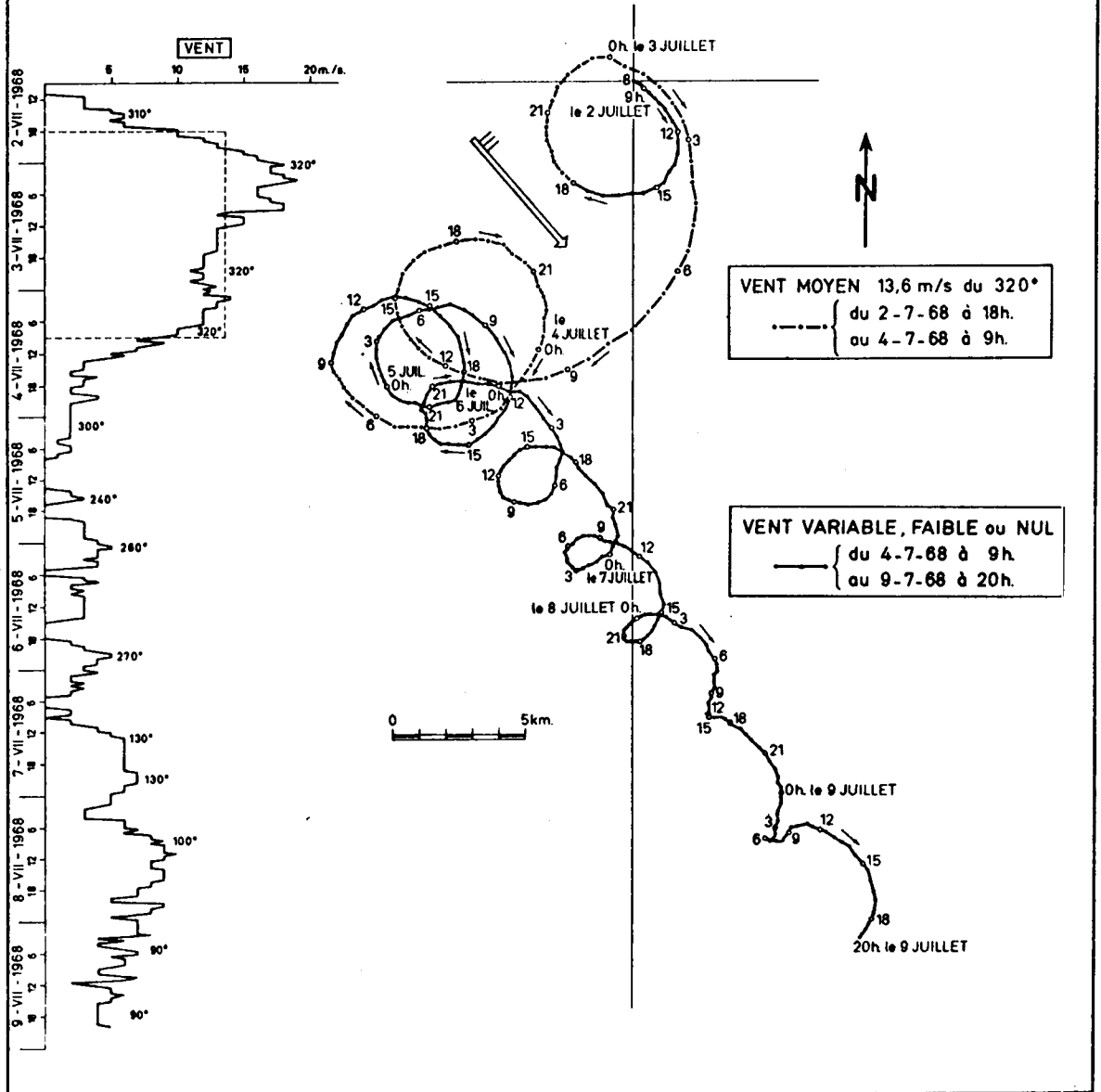

Figure 4-13: An Example of a Current Meter Record

personal communication in Appendix III.

In addition to these fixed station measurements, observations have been made using free floats making time versus distance measurements on both the surface and beneath the surface using acoustic tracking. However, the total available data on currents in the Mediterranean is sparse and we must rely on the judgment of experienced investigators as much as upon instrument recordings to make a useful model of the current environment along the projected pipe routes. Appendix III contains a report of a discussion between Henri La Combe and E. E. Allmendinger of the University of New Hampshire who represented the author in a Paris meeting in October, 1969.

Cross correlation of the current data with the statements of Miller, La Combe and Swallow received in personal interviews or correspondence results in the following assumed current profile variation along the pipeline route:

- 1) Near the coast of North Africa maximum surface velocity of 2.5 knots (4.5 ft/sec) dropping to 1 knot (1.7 ft/sec) at 300 feet and declining rapidly to less than 0.3 ft/sec at greater depths. The direction is due east. La Combe reports this pattern persists out from shore into water depth of 1000 fathoms, as much as 25 miles from shore. This reasoning is consistent with the major circulation pattern for the Mediterranean putting the entering water from the Atlantic in this eastward coastal

current.

2) From 25 miles off the North African shore to Minorca the available data shows maximum currents of 0.1 ft/sec at the surface as one would find with large eddy currents. There is no data available on the surface currents in this area, but Miller and La Combe concur that it is much less active than the Gulf of Leone so it is reasonable to assume that the maximum surface currents do not exceed 1 knot (1.7 ft/sec) and persist only to no more than a 200 ft depth.

3) Around the islands of Minorca and Mallorca the current velocities are unknown, but there is no reason to believe they exceed the 2.5 ft/sec storm currents estimated for the open ocean.

4) Between Minorca and Marsaille, Swallow's measurements and La Combe's estimates show a maximum surface current of 2 ft/sec declining rapidly to less than 0.3 ft/sec below the 300 ft depth. These currents were found by both Swallow and the crew of the Bouée Laboratoire to be rotating in a clockwise direction like large eddy flows. Therefore, the current direction can be assumed variable all along the pipeline track.

5) Near the French coast La Combe estimates a high current velocity of 3.5 ft/sec to the west under storm conditions and prevailing down to 300 ft in depth. The direction is generally west at all times. Below 300 ft, he estimates the current to be 0.3 ft/sec and also westerly.

In all of the foregoing the current magnitudes referred to are the horizontal components. The vertical components are assumed so small as to be negligible although there are long term movements of large water masses in the vertical direction due to density and other changes.

This current data is a very imperfect base for constructing a mathematical model of the current environment for the pipeline, but it is all that exists. So long as we assume a current model that exerts more force on the structure than actually ever occurs we will at least not underestimate the problem. Therefore, we assume current magnitudes and directions that will exert maximum possible forces on the pipeline and its supporting structure at all points along the line at the same time even though the currents are clearly periodic, in most cases, in both magnitude and direction. Figure 4-14 assumes this maximum drag force generating profile with the maximum current magnitudes discussed previously being assumed always perpendicular to the pipeline. This current model will certainly give an exaggerated picture of the total current forces acting on the total pipeline structure at any one time, but without more detailed information that simply does not exist, this is the only uncontestable design criteria to assume. Moreover, for any single ten-mile section of the line with its supporting towers, these maximum current

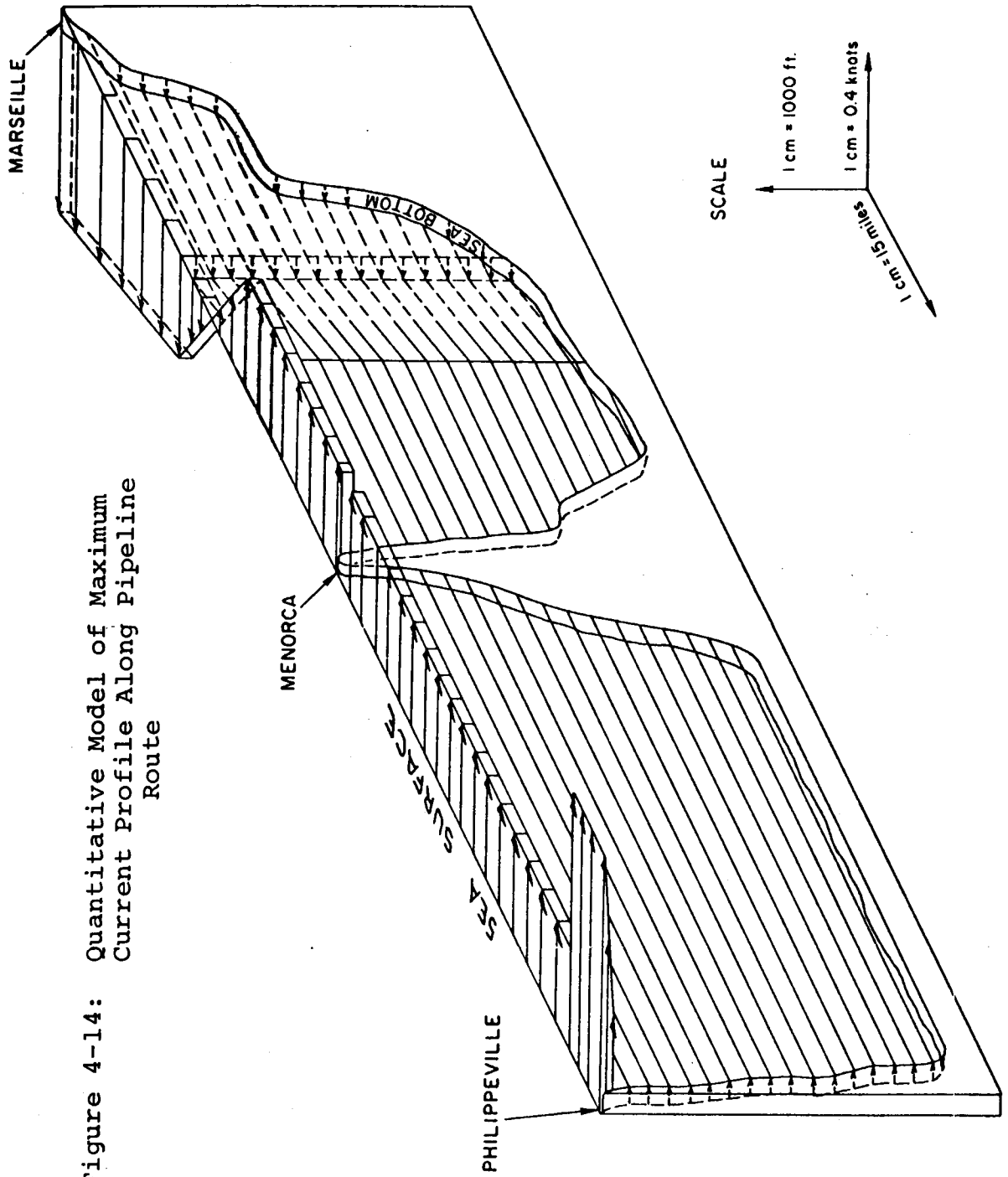

Figure 4-14: Quantitative Model of Maximum Current Profile Along Pipeline Route

conditions might actually all exist at the same time, and it is this maximum stress condition that must be allowed for in the design.

The current forces acting upon the pipeline and the cable structures are mainly those due to hydrodynamic drag and are expressed by Hoener (11) as

$$F = \frac{1}{2} \rho C_D A V^2 \quad (4.10)$$

where ρ is the water mass density (slugs/ft³), C_D is the drag coefficient (dimensionless), A is the cross-sectional area normal to the velocity (ft²), and V is the velocity of the stream (ft/sec). Because the available data indicates very slow vertical movement of the water, it is assumed that the significant velocities are in the horizontal plane as shown in Figure 4-13. The other current force is that due to frictional shearing but this force is small for a fairly smooth cylinder like a pipe (11) and can be neglected.

The current drag force acts on each component of the system in direct proportion to the square of the magnitude of that component of the velocity vector that is normal to the component's cross-section. The current drag forces for the various components of the system have been computed in the following manner:

1) Cable drag forces

For the cable legs of the trimoored structure the drag forces have been computed by first finding the current components normal to a unit length of one of the legs and the components tangential to the leg. The normal components are then used in the hydrodynamic drag expression (Eq. 4.10) to obtain the normal drag forces. The forces are then, in turn, separated into rectangular coordinate system vectors and combined to form a single set of three component force vectors for that unit length. C_D , the normal drag coefficient for the cables has been assumed to be 1.4 which is slightly larger for the new stranded steel cables than the 1.1 to 1.2 documented by Hoener for Reynolds numbers below the critical for new stranded wire rope. The higher value is used in an attempt to account for surface roughening due to corrosion. The density of sea water has been taken to be 64.0 lbs per cu ft. The tangential drag force on cables is often neglected but for this analysis it is taken to be:

$$F_T = \frac{1}{2} \rho C_T d V_p^2 \quad (4.11)$$

where C_T is the tangential drag coefficient (assumed constant when the unit length is parallel to the stream) (dimensionless), d is the diameter of the cable (ft), and V_p is the velocity component parallel to the cable (ft/sec) C_T for this analysis has been taken to be .035, which is

also larger than the .02 to .03 value given by Hoener.

2) Drag on cable buoyancy elements

The drag force on the glass spheres attached to the cables has been developed using the equation for hydrodynamic drag (Eq. 4.10). This force has always been taken to be completely in the direction of the current vector at the element since the element is so attached as to be free to orient itself in the direction of the current and has a constant cross-section in all directions. Only two tested high pressure elements are currently available in production quantities, a 48.8 lb net buoyancy element with a cross-sectional area of 2.1 sq ft and a drag coefficient of 1.57 and a 12.6 lb net buoyancy element with a cross-sectional area of 0.8 sq ft and a drag coefficient of 1.57 at sub-critical Reynolds numbers.

3) Apex buoy drag

The drag on the main apex buoy has been determined in the same fashion as that for the smaller buoyancy elements. The drag coefficient used for the elliptical buoy is 0.3 as determined by experiments by Savage (20) and also given by Hoerner (11). Since the buoy will be attached so that it can freely orient itself to the currents, the cross-sectional area normal to the velocity vector is the smallest possible area.

4) Pipe drag forces

The pipe drag force calculations have also been determined using (Eq. 4.10). As the pipe deflections will be kept small, the tangential drag forces have been neglected and only the normal forces considered. The drag coefficient for cylindrical pipe has been taken to be 1.2. The total current vector has been assumed to be exactly normal to the pipe to give the maximum possible drag force per unit length. In the event that the current is oriented parallel to the pipe, the reduction in pipe tension due to the decrease in the normal drag forces will more than cancel the added tangential force effect from tangential current drag.

4.2.1b Wave Forces in the Mediterranean Environment

In designing a submerged buoyant structure such as this pipeline system, we are concerned with the maximum forces exerted by surface waves at depths beneath the surface. These forces must be added to those exerted by currents to determine the maximum stresses developed in the pipe and its restraining cables and the motion of the structure.

Kinematics

By using classical, small amplitude, linear wave theory, one can represent the amplitude of a progressive, two dimensional gravity wave by (see Figure 4-15)

$$\eta = a \cos (kx - \sigma t) \quad (4.12)$$

where η = displacement of the wave surface

a = the wave amplitude ($\frac{1}{2}$ wave height)

k = wave number = $2\pi/\text{wave length}$

x = horizontal distance from origin

t = time

Ippen (31) shows that in the region $-h \leq y \leq \eta$ and $-\infty < x < +\infty$, the velocity potential for such a wave is

$$\phi = \frac{ag}{\sigma} \frac{\cosh k(h+y) \sin(kx - \sigma t)}{\cosh kh} \quad (4.13)$$

where the potential is defined by

$$u = \frac{-\partial\phi}{\partial x} = \text{the velocity in horizontal direction} \quad (4.14)$$

$$v = \frac{-\partial\phi}{\partial y} = \text{the velocity in vertical direction}$$

This velocity potential was obtained by solving the Laplace equation

$$\frac{\partial^2 \phi}{\partial x^2} + \frac{\partial^2 \phi}{\partial y^2} = 0 \quad (4.15)$$

for two dimensional, irrotational, incompressible fluid motion. The boundary conditions applied in the solution to the differential equation (4.15) are

- 1) The normal velocity at the bottom is

$$v = \frac{\partial \phi}{\partial y} = 0 \quad \text{on } y = -h \quad (4.16)$$

- 2) Integration of the equations of motion lead to Bernoulli's Equation (31)

$$\frac{\partial \phi}{\partial t} + \frac{1}{2}(u^2 + v^2) + \frac{P}{\rho} + gy = 0 \quad (4.17)$$

If this equation is linearized by neglecting u^2 and v^2 as small compared to the other terms, then it can be used to develop the second boundary condition

$$-\eta = \frac{1}{g} \left. \frac{\partial \phi}{\partial t} \right|_{y=\eta} = \frac{1}{g} \left. \frac{\partial \phi}{\partial t} \right|_{y=0} \quad (4.18)$$

Condition (4.18) assumes that the waves are small enough so that satisfying the boundary conditions

4.18 on $y = \eta$ is approximately equal to satisfying 4.18 when $y = 0$.

The horizontal u and vertical v velocities at any depth, $-h \leq y \leq \eta$, can be determined for a linear wave by applying equation 4.14 to the wave potential (4.13). For the deep water waves ($H \ll h$) that will act on the floating section of the pipeline system:

$$u = \phi_x = \frac{kag}{\sigma} e^{ky} \cos(kx - \sigma t) \quad (4.19)$$

$$v = \phi_y = \frac{kag}{\sigma} e^{ky} \sin(kx - \sigma t) \quad (4.20)$$

These velocity components are harmonic at any depth y . At a given phase angle, $\theta = kx - \sigma t$, the exponential function of y causes an exponential decay of velocity with depth beneath the free surface.

Wave Forces

Ippen (31) defines the wave force on an object to be the sum of the drag and inertia components. The evaluation of the forces is accomplished by first calculating the kinematic flow field from the surface wave characteristics in the absence of the object and then relating the forces to this kinematic flow field through drag and inertia

hydrodynamic force coefficients. Therefore, for a horizontal circular cylinder, the total force per unit length in the direction of the wave propagation is defined by the so-called Morrison equation

$$dF_I = dF_D + dF_I \quad (4.21)$$

The drag and inertia force components, dF_D and dF_I , respectively, are defined by

$$dF_D = C_D \rho D \frac{u|u|}{2} ds \quad (4.22)$$

$$dF_I = C_M \rho \frac{\pi D^2}{4} \dot{u} ds \quad (4.23)$$

where

ds = an elemental length of cylinder (ft)

ρ = mass density of water (slugs/ft³)

u = instantaneous horizontal water velocity (ft/sec)

\dot{u} = instantaneous horizontal water acceleration (ft/sec²)

C_D = hydrodynamic drag coefficient, the "drag" coefficient (dimensionless)

C_M = hydrodynamic force coefficient, the "inertia" or "mass" coefficient (dimensionless)

Equation (4.21) was developed by Ippen (31) for the forces on vertical pilings, but it applies to horizontal cylinders or pipes as well. Accordingly, equations (4.22) and (4.23)

become

$$dF_D = \Delta F_d = C_D \rho D \frac{u^2}{2} \quad (1) \quad (4.24)$$

$$dF_I = \Delta F_I = C_M \rho \frac{\pi D^2}{4} \quad (1) \quad (4.25)$$

for each foot of pipeline at a given depth. In this case, $\Delta F_D + \Delta F_I = \Delta F_T$, the total force per unit length caused by wave action on the pipeline, and ΔF_T is a function of time and the centerline depth of the pipe.

To determine the maximum wave force per unit length that could be exerted upon a pipeline of diameter D at any depth y it is only necessary to determine the maximum values of velocity u and acceleration \dot{u} , solve equation (4.24) and (4.25), respectively, and add them to find ΔF_T . From equation (4.19)

$$u_{\max} = \frac{ae^{ky}}{L^2} \sqrt{2\pi g} \quad \text{at any depth } y$$

and

$$\dot{u} = \frac{du}{dt} = k a g e^{ky} \cos(kx - \sigma t)$$

$$\dot{u}_{\max} = \frac{2\pi}{L} a g e^{ky} \quad \text{at any depth } y$$

For example, consider a unit length of pipeline, 3 ft in diameter, submerged 200 feet below the surface in deep water ($H \ll h$). For the Mediterranean La Comb (Appendix III) reports the highest storm waves to be 6 to 7 meters (22 feet) in height with practically no swell. Miller (28) states (in personal communications) that the Mediterranean waves are shorter in wave length than those of similar height in the Atlantic while Milgram (16) states that the largest Atlantic waves are of the order $a = L/20$. Therefore, taking the largest wave amplitude to be 11 feet, we calculate the longest Mediterranean waves will be of the order of 250 feet. Taking the drag coefficient $C_D = 1.2$ for cylindrical pipe and the inertial coefficient $C_M = 1.5$ (31), we find the maximum drag forces on the pipe will be less than 10^{-9} lbs per linear foot while the maximum inertial forces will be a somewhat more significant 0.02 lbs/ft. For deep water waves, the maximum vertical inertial force will be the same as the maximum horizontal inertial force at any given depth.

The conclusion to be reached about wave forces acting upon the pipeline is that they can be made insignificantly small by simply putting the line approximately 250 feet below the surface. This depth is readily accessible by divers for maintenance and clear of surface shipping, even allowing for the buoys above the pipe and 50 feet of upward arching of the pipe between cable restraints.

4.2.1c Special Forces

It is possible to postulate several special forces that might act upon a submerged pipeline as conceived by this investigation:

- 1) Collision with a submersible vessel.
- 2) Collision with a surface vessel if cables failed and a section of the line rose to the surface in mid-sea ship traffic.
- 3) Drag from fouled fisherman's nets.
- 4) The action of a Tsunami.
- 5) Turbidity currents caused by subsea land slides off the coastal shelf such as occur in Southern California.
- 6) Subsea earthquakes moving the ocean floor.
- 7) Dynamic forces caused by response of the pipe to vortex shedding induced by the current passing by it.

For these seven possible situations, the two key questions are: what is the probability of such a thing happening at all and what would be the consequences if it did? The answers can only be given in qualitative terms.

Collision with a submersible vessel

One of the design restraints already placed upon this system is that its possible motion, barring separation

of the pipeline, be sufficiently small that its location and the location of its cables are "known navigational hazards" to both surface and subsurface shipping, i.e., their position can be fixed on navigational charts within a hundred feet at all times. All subsurface vessels are equipped with sonar and the pipe, buoys, and the cable buoyancy elements are "ideal" sonar targets. Moreover, the cables will be widely separated, i.e., at least 900 feet apart. The exact navigational precision of military submarines is not published in the open literature. However, the much publicized polar crossings through ice channels by American submarines indicates an ability far greater than would be necessary to safely pass this pipeline. In the event of such a collision the possible consequences to the pipeline seem no worse than a complete break in the line, a possibility allowed for in the design and discussed in a subsequent section.

Collision with a surface vessel

This possibility seems more remote than collision with a subsurface vessel. It can only happen if the cables have failed allowing the pipeline to surface, and the pressure activated warning system (Appendix V) on the line that is part of the design should immediately alert the operators to this condition so that the vessels in the area can be

alerted to the hazard. However, in the event that such a collision did occur, the worst damage to the pipeline can once again be no more than a complete break in the line, an event that will be allowed for in the design analysis later on.

Drag from fouled fisherman's nets

This event could be a regular hazard to both the line and the fishermen because experience shows that such submerged structures become great attractions for all kinds of fish and will in turn attract fishermen. Large trawlers might be able to exert sufficient loads on the line or a tower to pull the pipe to the surface, but it is doubtful they could break the pipe because the net would distribute the load at the point of contact. On the other hand the damage to nets, trawler, cables and equipment and lost time make such an occurrence one to be avoided by the fishermen as much as by the pipeline operators. Small fishing boat equipment does not seem a hazard because the nets or lines would tear or be cut loose before they could damage a large spring such as this pipeline.

The action of a Tsunami

The Tsunami or tidal wave is simply a very long wave length wave ($1 \text{ mile} \ll L \ll 500 \text{ miles}$) in deep water ($h \ll H$) with

an unknown wave height (H) probably not exceeding one or two feet (See Figure 4-15) traveling at a high speed $C = \sqrt{gh}$. Referring to the equations for inertial and drag forces, it is obvious that such a wave will exert essentially zero force on the pipeline in deep water. The force is large however when the energy reaches shallow water and it slows down while building the wave height to sometimes 50 or 60 feet and causing rapid movement of the entire water column. Such conditions would present a serious threat to the bottom mounted sections of the line near the coast. However, tidal waves are a very remote hazard in this area, and they will not be considered in this study.

Turbidity currents

If turbidity currents exist in the areas where the pipeline reaches shore, they are not considered a hazard to the floating structure for the simple reason that they move along the bottom and neither the anchors or the cables present sufficient drag area to facilitate the generation of any large forces. They will, however, influence the design of the bottom mounted line. Such locations should be, and can be, avoided because such currents are local phenomena with historical patterns.

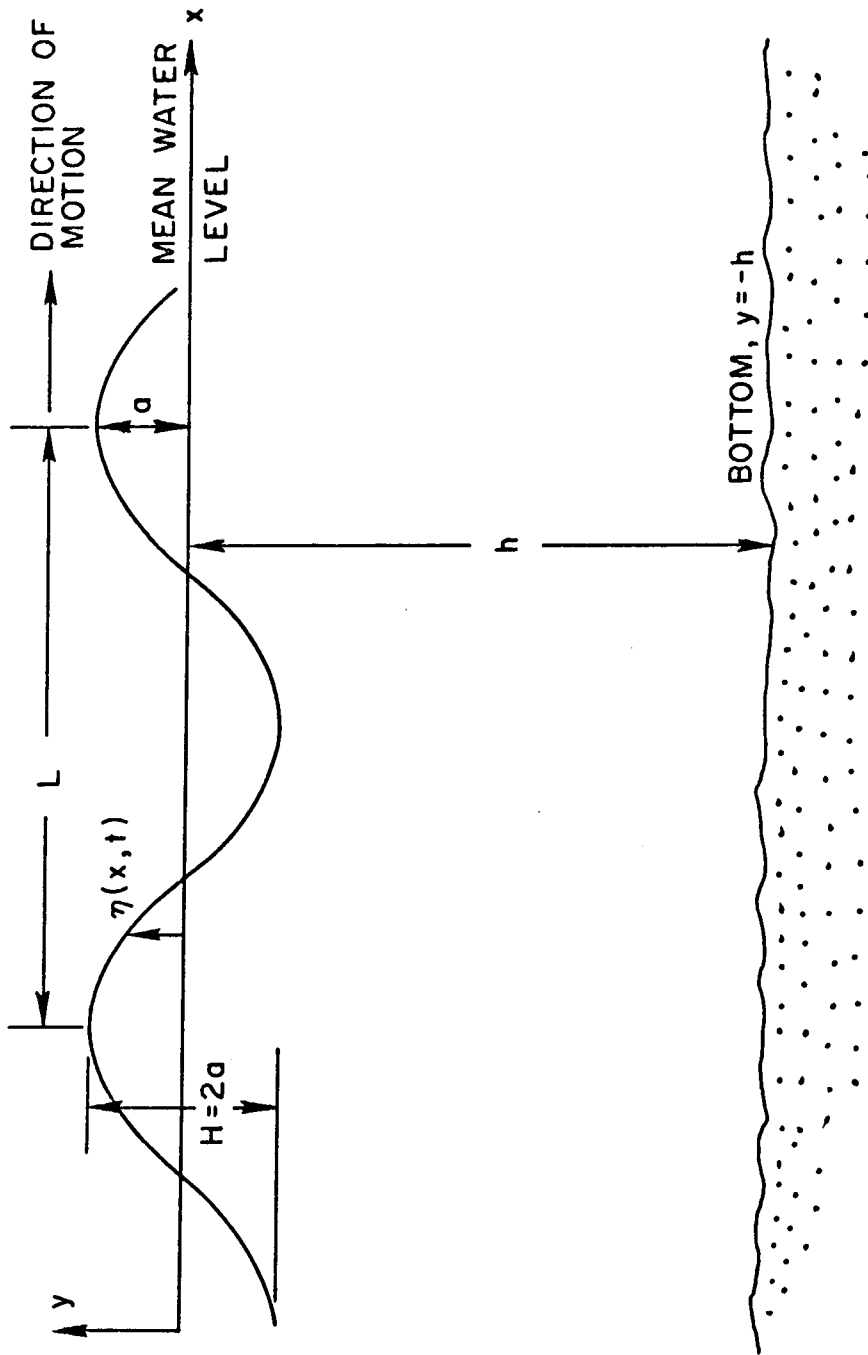

Figure 4-15: A Simple Harmonic Progressive Wave

Subsea earthquakes

The possible damage that might occur due to subsea earthquakes can be confined to what might happen if one of several anchors were moved tens of feet in any direction. A sensitivity analysis by Corell (32) for the General Motors Corporation's tests of Sea Spider II shows that any one anchor could be moved 5% of the depth (500 ft in 10,000 ft) from their original positions without changing the motions of the apex of the structure more than a few feet from what they were when the anchors were in their original position. This study indicates that 50 ft of anchor shift would be acceptable for a 1,000 ft depth. This distance is large movement for even a major earthquake; therefore earthquake movement will not be considered a hazard to the proposed pipeline.

Dynamic forces due to vortex shedding

A "vortex street" develops behind bluff obstacles such as a cylinder in two-dimensional or similar flow conditions. Hoerner (11) reports that experiments on cylinders suspended in a water stream in such a manner that they were free to oscillate in a lateral direction between springs (the condition for the proposed pipeline) showed lateral lift force coefficients of two to four times those for a fixed rigid body. As stated by Hoerner (11) this

effect is incorporated in and is an explanation of the realistic drag coefficients of fixed cylindrical bodies at subcritical Reynolds numbers, but the effect on oscillating bodies is to excite up and down swaying that can lead to possible fatigue failure. As has already been demonstrated, small lift forces and changes in the arching of the pipeline between towers can greatly magnify the stresses in the pipe; therefore, it may be desirable in this design to attach splitter plates or fingers to the pipeline on the expected down current side to decrease this possibility. No such oscillations have been observed or measured on any underwater taut wire buoy systems, and it is theorized that the varying currents and damping caused by the buoyancy elements negate the possibility of destructive vibrations developing, but there is no conclusive evidence.

The conclusion about possible special forces that might act on the proposed system is that their threat to the system can be prudently minimized by proven construction methods, and the crucial forces to be considered are those generated by currents, waves, and the pipeline buoyancy.

4.2.2 Gravity Forces Acting

The gravity induced forces acting upon the total pipeline system are the weights of the various components and elements, and the buoyancy forces acting on these

components and elements defined by Archimedes' principle.

4.2.2a Tower Gravity Forces

The basic components of a buoyant tower are its anchors, its three cable legs, the glass buoyancy elements attached to the legs to make them neutrally buoyant, and the large apex buoy which provides the major tension force for the tower legs.

Tower Anchors

In the computer programs in Appendix I which use the methods for determining tower motion and stresses described in Section 4.1.2a, each anchor is assumed to be always large enough so that its net weight (weight in air minus the weight of the volume of water it displaces) is always greater than any vertical force exerted on the anchor by tension in a cable leg.

Cable Legs

The cable leg weights per unit length used in the analysis are the net weights per unit length (cable weight in air minus the weight of the volume of water displaced). The weight of water in all calculations is taken to be 64.0 lbs/cu ft. As explained earlier, the distributed weight of a cable segment of a leg is lumped into a single

force at each lumping station in the Tower analysis.

Buoyancy Elements

The two sizes of proven, high pressure buoyancy elements available have net buoyant forces of 12.6 lbs and 48.8 lbs per unit. These elements are high pressure glass spheres with attachments, one manufacturer's description is given in Appendix IV. These buoyancy elements are attached at appropriate intervals along each Tower leg to make the leg neutrally buoyant. The attachment intervals will obviously vary according to the net weight of the cable per unit length.

The Apex Buoys

The Tower apex buoys used in this study are 2 x 1, oblate ellipsoids made of aluminum. The shape was selected because it presents an equal drag area in any direction in the horizontal plane, and therefore does not have a tendency to spin around a single point anchoring line. Also, the shape presents lower drag per unit of buoyancy than any other shape that has such symmetry, and hydrodynamic stability (20). The various buoy sizes considered for the Tower evaluation as described by one manufacturer, are given in Appendix VI.

4.2.2b The Pipeline Sublength Gravity Forces

A pipeline sublength is made up of the pipeline, the neutrally buoyant vertical restraining cables and their anchors, the intermediate buoys at the attachment to the restraining cables and the buoys at the tower attachments. There are other details such as the attachment slings, reinforcements and so forth, but the effects of these detailed components can be simply lumped in with the pipeline buoys in this analysis.

The Pipeline

The net gravity or buoyant force per unit length acting on a pipeline segment has been shown to be a highly significant factor in the design. It is the vector sum of the weight of the pipeline per unit length plus the weight of the gas in the pipeline per unit length plus the buoyant force equal to the weight of the water displaced by the volume of the pipeline per unit length. The weight of the gas in the line is a function of the gas pressure which varies with distance from the pumping station. Therefore, determining the net buoyancy or net weight of the pipeline to be used in this study has required a separate investigation using a method of analysis and the computer program by Boutin presented in Appendix II.

The approach, given in Appendix II, considers the

entire pipeline in two lengths, the section from Philippeville to Minorca (258 miles) and the section from Minorca to the coast of France (240 miles); for either of these two lengths, it is assumed that the outlet pressure must always be maintained at 700 psi, an industry specified pressure for distribution services. The important steps in the analysis are then:

- 1) First, a desired volume rate Q of gas throughput is specified in thousands of cubic feet per day at standard temperature and pressure (MSCF/D).
- 2) Next, for a given outside diameter of standard pipe (OD) and each of several different inside diameters (ID) the input pressure, to the 258 mile pipe length, required to deliver the desired Q at 700 psi at the outlet end is calculated. This is repeated for pipes of several different outside diameters, in 2 inch increments.
- 3) Using the input pressures obtained in 2) above for the several pipe sizes considered for a given rate of throughput, Q , the pressure distribution over the pipeline length is calculated.
- 4) Next, using the pressure distribution, the density of the gas as it varies with pipeline length is calculated.

5) For each member of a pipe family of a given OD and several ID's, the net buoyancy of the line as it varies along the length from inlet to outlet is calculated in 10 mile intervals. The result is a plot of net buoyancy of the line versus distance as shown, for example, in Figure 4-16.

6) For a given gas throughput rate Q there is one standard pipe OD and ID that offers the closest approximation of a 2 to 1 pressure ratio of the inlet pressure to the outlet pressure of the line while the pipe remains positively buoyant. These conditions have been set as the most desirable for the design of the pipeline for reasons that:

- i) a 2 to 1 pressure ratio is the maximum considered economic, based upon industry experience in pipeline construction.
- ii) it is not considered feasible to introduce intermediate pumping stations in the depths of water in this location except on the island of Minorca.
- iii) the smallest OD pipe for a given rate of gas will result in the lowest drag forces on the system, and therefore permit the lightest and most economical system from an original subsurface structure investment standpoint.

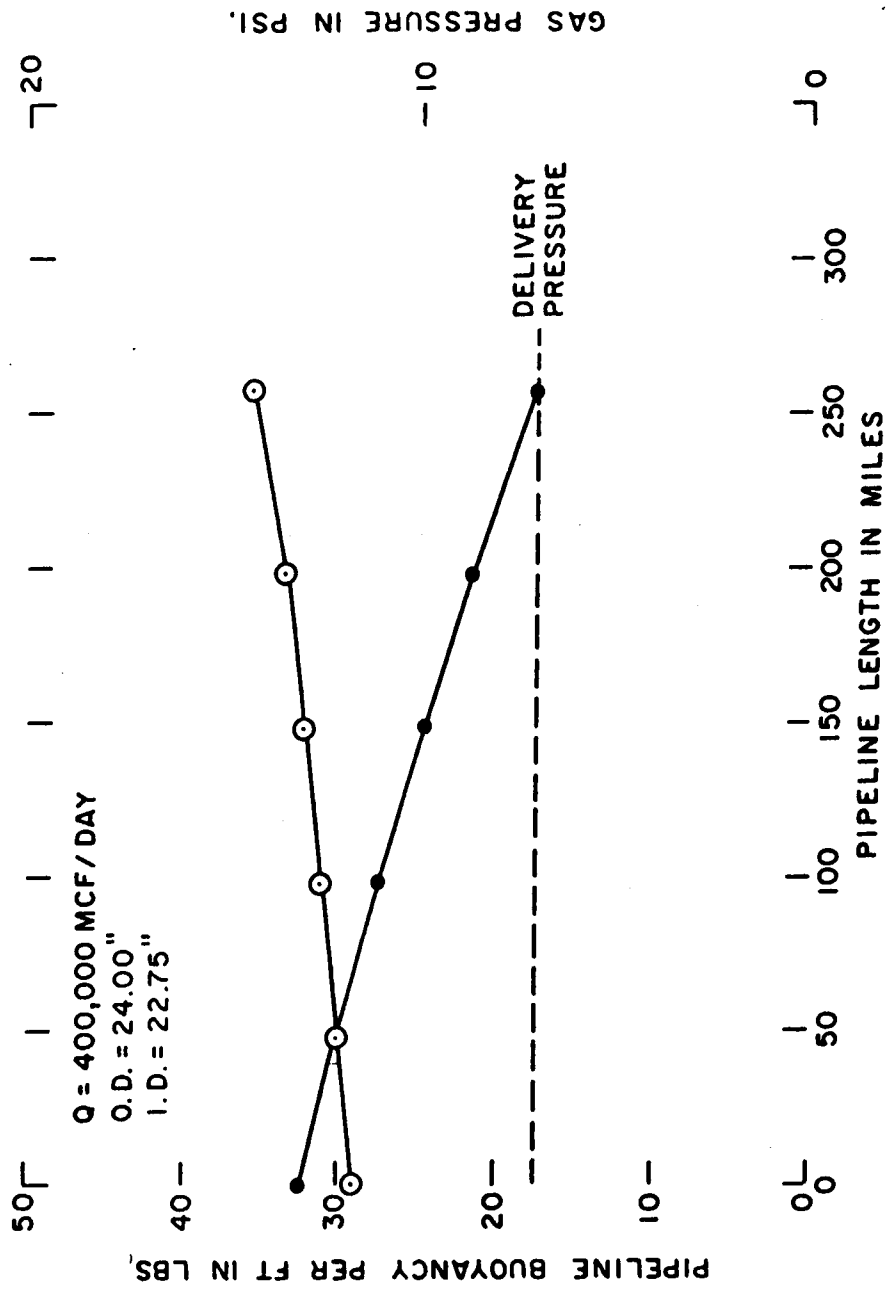

Figure 4-16: Example Pressure and Buoyancy Profile Along Pipeline

iv) the pipeline must remain positively buoyant during construction to use the installation method that has been proposed in Appendix IV.

With a plot such as Figure 4-16 for the selected pipe size for a given gas rate Q , it is then possible to decide what net buoyancy per unit length to use in the analysis of stresses and motions. This is accomplished by using the criteria that the line must be always positively buoyant at any location regardless of the circumstances that may occur. This means that if the pipeline breaks at any location, causing the automatic shutoff valves to close at the two towers on either side of the break, the averaging of pressure that takes place in the shut down pipeline must not cause any section to become negatively buoyant. Therefore, if the pipe is differentially weighted at each joint so that gas at average pressure in the line will not cause any part of the line to become negatively buoyant then the line is properly ballasted. In the case of Figure 4-16 this would result in the inlet end of the pipe being weighted with an additional 29 lbs net weight per foot in order to make it nearly neutrally buoyant. This same 29 lbs per foot would be put on each joint until the 138 mile mark was reached. This is the point where the pipe net buoyancy is equal to what the net buoyancy/ft. of the entire line would be if it were all at average gas pressure, i.e., if the

pipe were shut off at both ends and the pressure allowed to reach equilibrium. At the 138 mile mark the net buoyancy of the pipe in Figure 4-16 with 29 lbs net weight per foot added is 3.2 lbs per ft. Thereafter, weight added can be increased downline so that the net buoyancy of the pipe will be a constant 3.2 lbs per foot when the gas is flowing. For instance, the weight per foot added to the last joint of pipe at the outlet end would be equal to: 35.6 lbs - 3.2 lbs (net buoyancy allowed) = 32.4 lbs per foot. With such a scheme, a shut off at any place in the line, causing automatic shutoff at both ends, would never result in the gas pressure equalizing and causing any part of the line to go negatively buoyant. The maximum net buoyancy would occur at the 138 mile mark, just beyond the shutoff on the lower pressure side where the pressure would drop and cause the net buoyancy per foot to increase. The increased buoyancy would be equal to the gas weight per foot of pipeline at the original pressure of 1012 psi minus the gas weight per foot of pipeline at the new average pressure in line between 138 miles and the end of the line where the pressure was 700 psi before the shut down. This new average pressure is not given by:

$$P_{avg.} = \frac{2}{3} \left(P_1 + P_2 - \frac{P_1 P_2}{P_1 P_2} \right)$$

where $p_1 = 1012$ psi

$p_2 = 700$ psi

because we are dealing with only the last half of the pressure drop curve for a flowing pipeline. A simple average of pressure (and therefore density) is more realistic. This gives a conservative 1.5 lbs per foot increase in net buoyancy at the 138 mile mark or a maximum buoyancy of the pipeline of 4.7 lbs per foot to be used in the motion and stress calculations for the pipe sublengths and buoyant towers.

Obviously, it will be very difficult to be so precise in the actual pipeline construction procedure, and the water density could vary enough to cause a 0.1 lb/cu ft variation in the water weight density during a year. Therefore it will be necessary to allow for part of the pipe actually going slightly negatively buoyant in the event of a pressure failure and shut down. Therefore, the maximum pipe gravity force for the example in Figure 4-16 is better specified as $- 5 \text{ lbs} \leq \text{wt/ft} \leq + 3 \text{ lbs}$. This tolerance span of 8 lbs is 5% of the pipe weight in air, a reasonable design specification. The possibility of a pipe sublength going slightly negatively buoyant in the event of a pressure accident can be allowed for in the design by specifying that the intermediate buoys above the vertical cables on the sublength have sufficient buoyancy to allow for the

tolerance of negative buoyancy that could occur in any pipe sublength. This provision will require somewhat larger buoys, but the added drag force incurred on each buoy will be only tens of lbs per buoy for the current velocities involved and will have negligible effect on the overall system design.

The Intermediate, Vertical Cables

The intermediate, vertical cables shown in the schematic Figure 4-4 will be made neutrally buoyant by adding buoyancy elements in the same fashion as for the tower legs. Having negligible net weight themselves, they will be assumed sufficiently anchored so they supply vertical, downward forces exactly equal to the buoyancy of the pipe segments they restrain plus the buoyant force of the intermediate buoy supporting attachment hardware and other added weight. These cables will therefore supply varying downward force (and will have varying required diameters and breaking strengths) depending on the spacing selected and the net buoyancy of the pipe system they are anchoring.

The Intermediate and Upper Tower Buoys

The intermediate buoys, already referred to, will supply a buoyant force, at each intermediate cable location and

over the towers, that is large enough to cancel the weight of attachment hardware, the added weight of the tapered pipe joints required to distribute the added stresses due to bending at these locations, and any other anticipated weight variations in a pipeline sublength. Therefore these buoys will vary in size according to the spacing of the intermediate cables, the pipe size and so forth. They will also be 2 x 1 oblate ellipsoids to minimize drag resistance.

These gravity and buoyant forces acting on the pipeline sublengths and towers have been incorporated into the analysis of the pipeline and tower configuration and stresses that is presented in computer program form in Appendix I. The quantitative values to be given each of these forces is dependent upon the size of element or component selected, and these, in turn, depend upon the geometry of the particular pipeline system proposed. Therefore, each proposed pipeline size or tower spacing with attendant cable sizes, buoy sizes and so forth requires individual detailing of the sizes of the elements and components for each trial run of the computer program analysis. This is a laborious procedure, but there is no substitute if real, standard components are to be used in the technical and economic evaluation.

4.3 DETERMINING THE TOWER SPACING, TOWER COMPONENT SIZES, AND OTHER SIGNIFICANT DESIGN PARAMETERS OF A PIPELINE SYSTEM

When this investigation was initiated it was visualized that the end result would be an "optimized" total pipeline system for any specified volume rate of gas throughput. This visualized optimization procedure would reflect a tradeoff of size of buoyant tower components (and cost) vs. tower spacing. The result was expected to be primarily a function of the forces acting, the resulting tower and pipe configuration and stresses caused, the cost of elements and components and so forth i.e., a highly quantified analytical procedure could be used. As the investigation has proceeded, however, it has become apparent that there are many practical restraints on such a system that are equally important to the design decision process. These other boundary conditions can be divided into two categories: those arising from the requirements of installation of the towers using available sizes of vessels, equipment, and components of construction; and those arising from a practical method of assembling and installing such a long pipeline at sea using procedures and techniques that do not depart appreciably from ones already proven and accepted by the marine pipeline industry.

Tower Installation Limitations

If a system were selected that required 1000 towers (most of them about 9000 feet high from the bottom to the apex buoy judging from the bottom topography of the crossing), and each tower took just 3 days to install, it would require 6 installation-ship years to construct the towers alone. This staggering result which allows for no delays due to weather indicates the practical limits on minimum tower spacing.

However, there is a more definitive limit to the minimum distance between towers. The apex buoys of the towers cannot be allowed to move more than 100 feet from their equilibrium positions (under gravity forces only) when acted upon by current induced forces. Otherwise, their motion will subject the pipe to large bending movements, present an unknown hazard to submarines or, if the motion is vertical, the buoys will exceed any feasible crush depth limit and sink. Savage and Hersey (20) have shown that the minimum displacement of the apex of such a structure under given acting current forces will occur if the tower has a geometry as presented in Figure 4-17. This tower geometry means that it is not possible to put two towers of equal height closer together than a distance approximately equal to the water depth without showing crossed cable legs in a plan view of the system. It is an

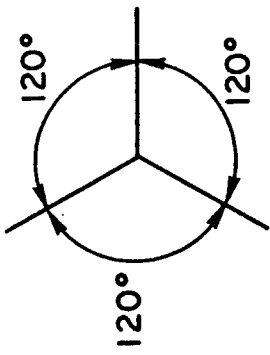

PLAN VIEW

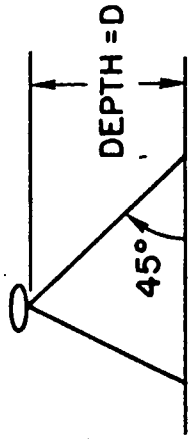

SIDE VIEW

POSSIBLE PAIRINGS

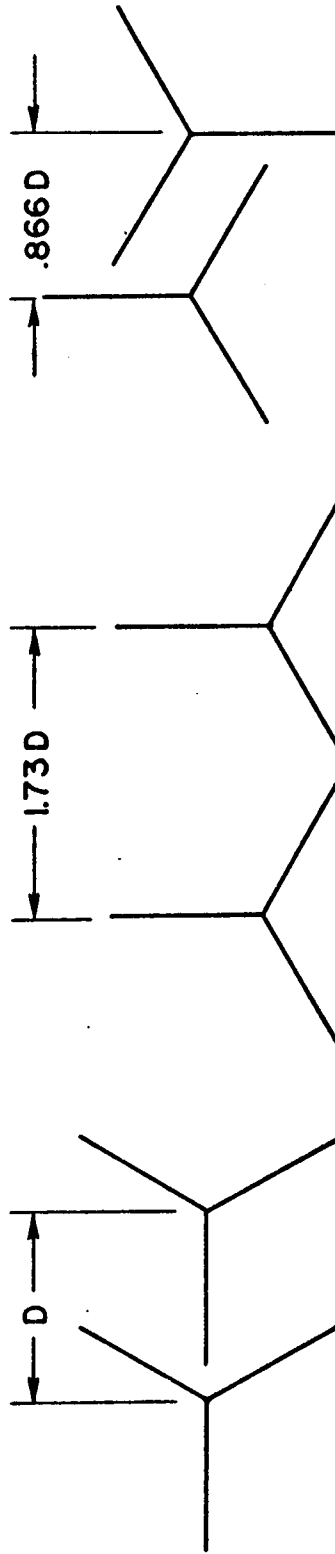

Figure 4-17: Geometry of Buoyant Tower and Possible Close Pairing of Towers

accepted axiom of sea cable installation that two cables lowered in the same location will become hopelessly tangled. This rule of experience is particularly pertinent in the case of such buoyant towers with all of the buoyancy elements attached to the cables to assist one cable to tangle with another. Therefore, the minimum distance between towers will be taken to be no less than the maximum depth of water in the location for reasons of installation caution alone.

A second practical limitation on tower parameters is on the maximum diameter of cable legs. This limit is approximately one inch diameter. There are two reasons for this limit, either one being sufficient:

- 1) The net weight in water of a one inch diameter, torque balanced, steel cable is about 1.0 lbs/ft. The only proven buoyancy elements available to use have a maximum buoyancy of 48.8 lbs/unit. This means one element must be attached about every 50 feet on a one inch diameter cable. This is the same distance between the smaller buoyancy elements used on the two Sea Spider buoyant structures. Because cable weight increases with the square of diameter, it becomes clear that the system tower legs rapidly become effectively an unwieldy continuous string of elements as cable size increases. Larger elements are not proven and are not available in volume and would present a very

difficult handling problem to get off the vessel and into the water.

2) With the depth of the water to be traversed for the crossing being mostly about 9000 feet, most of the towers will require about 37,000 feet of cable. While a large conventional cable laying vessel can store many times this length of one inch cable, it is not the ideal type of vessel to precisely maneuver itself in the fashion that has been found necessary to install these buoyant towers. A small ship with a large clear after deck (and less available cable deck storage) and directional propellers is really necessary. Consequently, it will be necessary to resupply the installation ship regularly with cable. Cable of significantly larger diameter than one inch will present a very difficult handling problem. The cable tensioning system would have to be much larger than any yet used for installing such towers, and the costs would become unpredictable based upon past experience.

These two design limits in the towers drastically curtail the allowable tower spacing range, setting effectively maximum and minimum spacing.

Limitations on Tower Spacing Due to Pipe Installation Method

The pipeline installation is visualized as a continuous process, conducted from a single pipe laying barge with attending tugs and supply barges to replenish the pipe

inventory on the installation barge. As is now the practice in marine pipeline laying, the pipe will be welded in a continuous string and payed out over the end of the barge. Unlike present practice, the barge will not be anchored, but held on course by multiple directional propellers just as many floating oil drilling rigs hold station over the drill hole.

The speed with which the pipe can be payed out is limited by the rate of welding that is possible. According to Bechtel Corporation (33), it is possible to weld and coat approximately 3000 feet of 30 inch marine pipeline in a continuous 24 hour operation. This means that it will require 3 days just to weld 9000 feet of 30 inch diameter pipe to span the minimum distance between pipe towers. Three days is the length of time that it usually takes the weather to change from an originally predicted, fair condition into storm conditions (Sea State five or greater), when it will become difficult for the pipe laying barge to hold station. For smaller diameter pipelines the welding time will be shorter by a margin depending on the wall thickness and the diameter. However, the time required for laying a 24 inch line with a wall thickness sufficient to withstand the forces with the magnitude involved in this study will still be close to 24 hours per 3000 foot. Since a study by Boutin (Appendix II) for optimum pipe sizes shows

that the minimum pipe OD will be 24 inches for the volume rates that are considered, it is therefore valid to assume 3000 feet per day as the most rapid pipe laying rate, and three days to be the shortest time required to put out 9000 feet.

Now, if the weather changes to storm conditions, drag forces due to wind driven currents and waves will develop that will make it impossible to hold the line straight, and will overstress the line and cause it to buckle. Therefore, it will be necessary to disconnect the pipeline from the laying barge and pull the free end down below the surface. This eventuality means that a tower must already be installed ahead of the pipeline laying barge so that the disconnected pipeline end can be plugged, pulled down, and attached to the tower which will supply the tension (at subsurface conditions)* required to hold the line in place until the weather abates. Then, the pipe laying barge can return to

* It is to be noted that the empty pipeline will be too buoyant at this stage by an amount equal to the weight of gas that will ultimately flow in the line. The line must therefore have removable, distributed weight added to it during installation that can be removed later when the gas is put into the line. Trimming the line net buoyance during installation will be a significant procedure to be worked out and executed. The trimming procedure must be done each time the line volume rate is increased after installation until the ultimate rated capacity is reached. A trimming procedure is discussed in Appendix IV along with a discussion of the proposed installation procedure.

its task, pull up the pipeline end and continue welding and laying out the line. Therefore, the installation requirement of always being ready to disconnect the barge and attach the pipe end to a tower that is close enough dictates that the towers be as close together as possible. Since the minimum tower spacing has already been determined to be approximately equal to the water depth in any location to reduce the risk of cable crossing and tangling of one tower with another, the tower spacing is completely specified by the requirements of installation rather than by the forces involved. The analysis of motions and stresses in the pipeline system will therefore have to start with the tower spacing already specified. The purpose of the computer analysis is, therefore, to determine only the sizes of cables and elements necessary to withstand the stresses developed.

4.3.1 The Final Analytical Model

It is now possible to decide on the final analytical model from which the major details of the structural design of the system can be determined so that the capital investment involved can be estimated. The model will be as follows:

- 1) The floating part of the pipeline will be divided into sublengths between towers as already discussed.

- 2) Each sublength will be 9000 feet long.
- 3) The vertical cables used between towers will be 900 feet apart and serve to relieve stresses due to buoyancy of the pipe as much as possible. Placing the cables closer together than 10% of the depth is not prudent because of tangling possibilities.
- 4) The pipe buoyancy per foot will be specified for each pipe size considered using the procedure already outlines.
- 5) The pipe sizes used for this feasibility study have external diameters of 24 inches, 30 inches and 36 inches for ultimate gas daily delivery rates of 400,000 MCF, 800,000 MCF and 1,200,000 MCF, respectively. These pipe sizes are those giving an ultimate pressure ratio of 2 to 1 for the particular pipeline size and rate of throughput (Appendix II) and are considered optimum from a subsurface construction standpoint.
- 6) The current forces acting on both the tower and pipeline and the buoyancy forces acting will be constant and the maximum expected at any depth.
- 7) The resultant pipe reaction on the tower will be that which will exist if the pipe broke and all the tension forces in the pipe were transferred

to a single tower.

- 8) The apex of each tower will be 300 feet below the surface and no part of any pipe sublength will be permitted to rise above a 250 foot depth (below any possible wave force of significance).

These specifications combined with previous assumptions about wave forces and reaction forces result in a maximum loading condition for the tower existing when the pipeline is not completed and a single tower must accept all of the reaction due to a pipeline sublength's current and buoyancy loading i.e., F_{xpipe} , F_{ypipe} , F_{zpipe} as shown in Figure 4-18.

Before proceeding further, it is necessary to establish Figure 4-18 as representative of the maximum loading condition on a tower for what happens when the pipe breaks as well as when the installing ships cannot hold tension on the pipe during installation of a sublength. It is not difficult to visualize a broken pipe section filling with water, sinking and pulling down the tower to which it is attached until the tower buoys are crushed; should this whole process then begin repeating itself down the line to each succeeding tower the ultimate destruction of the entire pipeline is inevitable. Obviously this catastrophe cannot be permitted to happen. It will therefore be necessary to have pressure activated pipe safety valves and explosive-bolted pipe flanges immediately preceding

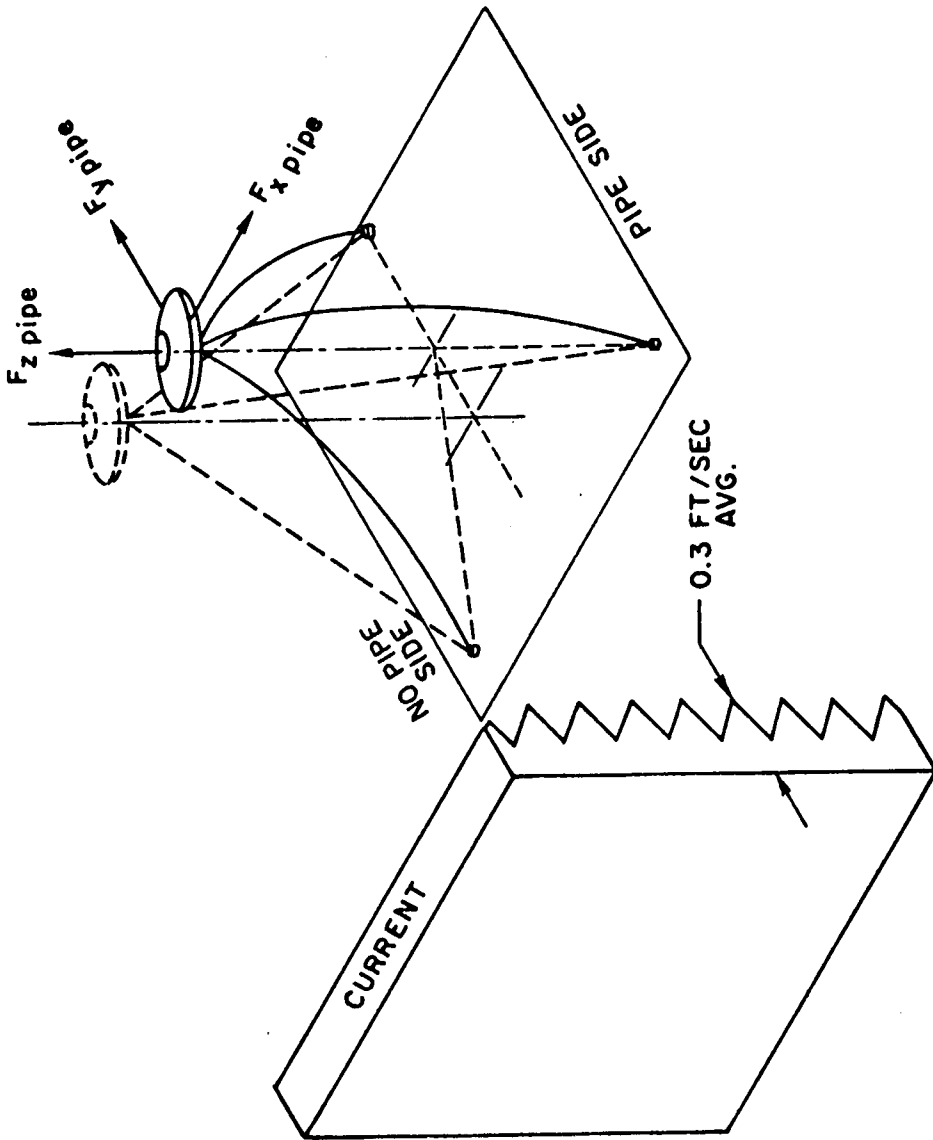

Figure 4-18: Buoyant Tower Under Current Force and Pipe Loading

and following each buoyant tower to cut off and seal the pipe at the two towers that embrace the broken sublengths. Then Figure 4-18 becomes valid for both the broken lines and the free end condition during installation. The particulars of these safety devices are dealt with in the Appendix V.

With these design specifications and using all the previous assumptions made in this chapter, the following procedure was then used.

4.3.2 Procedure of Design Analysis

The procedure will be demonstrated by an example using the 24 inch pipeline.

1) The pipeline sublength is subjected to maximum current and buoyancy forces and the computer program in Appendix I used to determine the reaction on the towers.

2) These reactions are then applied to the towers in the second computer program in Appendix I to determine tower motions and stresses. Particular buoy sizes and cable sizes are simply guessed in the beginning. If they prove to be too large or too small from the motions or stresses calculated, the sizes are changed until acceptable results are obtained. A safety factor of 2 is used in determining stress limits for cables. The vertical or horizontal motion of a tower apex is not permitted to exceed 100 feet. The procedure is simple and a matter of trial

and error until an acceptable answer is reached. The variables are simply the cable size and size of the apex buoy. Changes in these components affect the drag forces and the cable tensions, which are appropriately adjusted within the computer program.

Finally, the maximum tension in the tower cables and their motion are for towers oriented as presented in the third of the three possible tower orientations shown in Figure 4-17. Computer runs made on each of the two possible attitudes of the tower relative to the current show that the maximum tower buoyancy and cable strength is required when one of the three legs is parallel to the current and down-current in a plan view. Even though only every other tower will present this weakest orientation to the current, all buoy and cable sizes are based upon this maximum requirement.

The results of the analysis for all three pipeline sizes giving the size of buoys and other components finally required for a pipeline sublength 9000 feet long are given in Table I. Since 80% of the nearly 500 mile long line will be in water approximately 9000 feet deep, it will be assumed that the entire pipeline is made up of such 9000 foot sublengths and the hardware specified in Table I. These data may now be used to determine capital investment requirements in the cost-feasibility analysis.

TABLE I*

Case Numbers	1	2	3
Final Flow Rate Q (MMSCF/D)	400	800	1200
Pipe Size (in)			
OD	24.00	30.00	36.00
ID	22.75	28.25	34.00
Pipe Drag Force (lbs/ft)	0.33	0.27	0.22
Mex Pipe Buoyancy Force (lbs/ft)	5.0	8.5	12.0
Intermediate Cable Specs. ***			
Diam. (in)	1/2	5/8	3/4
wt/ft (lbs)	0.319	0.493	0.722
Intermediate Buoy Size (Net Buoyancy in lbs)	10,000	15,000	20,000
Net Forces on Pipe Caused by Intermediate Buoy & Cable/Station **			
F _x (lbs)	0.0	0.0	0.0
F _y (lbs)	-500.0	-500.0	-500.0
F _z (lbs)	0.0	0.0	0.0

* Table I is continued on the next page. The maximum tensions in the tower legs and maximum motions of the apex are computed for the tower so oriented that one tower leg is pointed directly up current in a plan view.

** The drag forces do not change appreciably for buoy size increase so a constant 500 lbs/int. sta. (max. value) is used.

*** Specs are from Appendix VI.

TABLE I (continued)

Case Numbers	1	2	3
Intermediate Anchor Size (lbs)	12,000	17,000	22,000
No. of 16" Glass Balls/Intermediate Station (Number)	60	92	133
Tower Buoy Size (Net Buoyancy in lbs)	40,000	50,000	60,000
Tower Buoy Drag Area (ft ²)	71.5	82.6	90.0
Tower Cable Specifications ***			
Diam. (in)	7/8	1	1-1/8
wt/ft(lbs)	.995	1.28	1.62
No. of 16" Glass Balls/Tower (number)	780	1,000	1,270
Tower Anchor Size- 3/Tower (lbs)	35,000	41,000	48,000
Max Tension in a Tower Leg (lbs)	40,000	51,000	63,000
Max Motion of a Tower Apex (ft)	1	5	10
Max Motion of Pipe Sublength Midpoint (ft)			
x	23	30	32
y	350	288	245
z	1	5	10

*** Specs are from Appendix VI.

5. INVESTMENT, COST AND RETURN
ON INVESTMENT ESTIMATES

Any investment and cost analysis of the proposed pipeline system that requires installation and construction methods that have no precedent must be based upon educated guesses. Therefore, the investment and cost estimates presented herein are a result of

- 1) Estimates by manufactures of the cost of the various components involved in the construction of the pipeline.
- 2) Construction installation costs extrapolated from the present cost of installing marine pipelines using lay barges and support equipment such as pipe barges and tug boats.
- 3) The experience of the author and the United States Navy with the time and equipment required to install trimoored buoyant towers of the type used in this proposed system.

No effort has been made to allow for inflation which is now a predominant factor in all heavy construction costs. Also, there has been no attempt to reduce this proposed cost by the introduction of new and untested methods of construction which are indicated technologically, but would produce cost and investment figures that are not based upon

present state-of-the-art. Introducing untried technology adds an element of risk beyond that readily acceptable in the feasibility analysis of the cost and investment of such proposed projects.

5.1 ESTIMATED INVESTMENT

Table I of the previous Chapter provides the basis for estimating the required investment for a pipeline of the three capacities considered. In the estimating procedure there are several necessary assumptions:

- 1) The total pipeline from inlet to outlet is 500 miles (5280 ft/mile) long.
- 2) Of the total length, 490 miles is floating and the remainder (10 miles) is bottom mounted in an average depth of water of 90 feet. This 10 miles of line accounts for those parts of the line entering and leaving the surface pumping and discharge stations.
- 3) There are two pumping stations, one at Philippeville and one at Minorca.
- 4) No investment provision will be made for distributing the gas after it leaves the outlet end. It will be assumed that the gas is sold at that point.
- 5) The pipeline is assumed to be 9000 feet above the bottom throughout the 490 mile portion. This is

actually true for only approximately 80% of the length, but the assumption provides equivalently for the towers being placed closer together in the shallow water area where the current may be found to exceed the 0.3 ft/sec maximum that has been used as the constant current velocity profile for the analysis in Chapter 4.

- 6) The towers are assumed to be 9000 feet apart and the vertical, intermediate cables to be 900 feet apart (the assumption for the calculations leading to Table I, Chapter 4). Therefore, there are 287 towers for the 490 mile floating line.
- 7) Finally, the pipeline sublengths between towers are assumed to be 9050 feet long (the same assumption used to make the calculations leading to Table I, Chapter 4).

To illustrate the investment estimating procedure, the 400 MMCF/D, 24 inch OD pipeline will be used as an example for all calculations.

5.1.1 Tower Materials

5.1.1a The Apex Buoys

The 40,000 lb apex buoys required by the 400 MMCF/D system are shown in Appendix VI to cost \$15,500 each in unit lots of 100. Allowing 10% for transportation from the U.S.

West Coast brings the price to about \$17,000 per buoy or \$4.9 million for the 287 apex buoys required.

5.1.1b Cables

Each tower requires 40,000 feet of 7/8 inch diameter plastic coated cable costing 70¢/ft (personal communication with Mr. G. H. Bonger, Bechtel Corporation, San Francisco) or \$28,000 per tower. This amounts to \$8.1 million for all the towers.

5.1.1c Cable Buoyancy

To make the tower cables neutrally buoyant, 16 inch glass spheres are attached, each with a net buoyancy of 48.8 lbs. Table I shows 780 spheres costing \$48.00 each (Appendix VI) are required for each tower; \$37,000 per tower or \$10.6 million for all towers for the 24 inch pipe-line size.

5.1.1d Fittings

Shackles, swivels, cable clamps, and so forth will be required to assemble the tower legs and anchors. Based upon the experience of Sea Spider I (20), their cost is estimated to be \$2,000 per tower including the U-bale attachment on the apex buoy (see Figure 4-3). Total cost will be about \$600,000 for all towers.

5.1.1e Anchors

Anchors are estimated to cost 10¢/lb delivered in North Africa and shaped to hold horizontal forces (20). For three anchors per tower weighing 35,000 lbs each (Table I) the cost is \$10,500 per tower. Total tower anchor cost is \$3 million.

5.1.1f Total Tower Material

The total tower material costs are \$27.2 million for the 24 inch pipeline.

5.1.2 Tower Installation

It will require two days to install one tower including replacing cable drums, etc., for a 24 hour/day operation. This estimate is based upon the experience of Sea Spider I (20) and Sea Spider II (personal communication with Mr. Rick Swenson, formerly of General Motors Corporation, now of U.S. Navy Underwater Sound Laboratory, New London, Connecticut). The ship type proposed to do the installing will cost \$10,000/day including the crew (personal communication with Mr. Tom Cummings, U.S. Navy Underwater Sound Laboratory, New London, Connecticut). However, the weight and length of cables required will require continual resupply of the installing vessel. Estimating that two crane supply barges with tug boats are required

at \$5,000/day each brings the cost of the installation operation to \$20,000/day. If each tower requires two days and two additional days are conservatively allowed for bad weather and moving time, the cost of installation per tower is \$80,000/tower or \$23 million for all towers for the 24 inch pipeline. For the 30 inch and 36 inch pipelines, a major increase in installation cost arises from the need for more transporting barges for the larger components. One additional barge and tug is assumed to be required for each 10,000 lb buoyancy step increase in tower size; also the installation time will be increased because more glass floats must be attached to the heavier cables and heavier components must be handled. Installation time (including time lost to weather) is assumed to increase to 4.5 days per tower for the 30 inch pipeline and 5 days per tower for the 36 inch pipeline. Therefore, with the increased transport and tug costs, the installation of the towers for these larger pipelines will cost \$32.3 million and \$43.1 million, respectively.

5.1.3 Pipeline Materials Including Intermediate Buoys
Cables, Anchors

5.1.3a The Pipe

Assuming that pipe type X52 will be used, the 24 inch OD, 5/8 inch wall thickness pipe assumed for the

cost estimates and buoyancy calculations will cost approximately \$14/ft delivered (Bechtel Corporation estimate - personal communication with Mr. G. H. Bongers). Each 9050 foot pipe sublength will therefore cost \$127,000. Including a \$1/ft extra charge for wrapping to prevent corrosion brings the pipe cost for the entire floating part of the pipeline to \$39.2 million for the 24 inch pipeline.

5.1.3b Intermediate and Secondary Tower Buoys

Each intermediate or secondary tower buoy for the 24 inch line will require 10,000 lbs net buoyancy to allow for the weight of the thickened section of pipe at the cable connection (to allow for bending stresses) and to allow for possible gas density changes as discussed in Chapter 4. Based upon manufacturer's estimates for larger buoys, the smaller buoys are estimated at \$10,000 each or \$100,000 per 9050 foot sublength. Total cost for these buoys for the 24 inch line is estimated at \$28.8 million.

5.1.3c Intermediate Cables

The $\frac{1}{2}$ inch, plastic coated, intermediate cables (3 x 19) will cost approximately 30¢/ft (Appendix VI). For each pipeline sublength, 81,000 feet of cable will be required at a cost of \$24,000. Intermediate cable costs

are estimated at \$6.9 million for the 24 inch line.

5.1.3d Intermediate Cable Buoyancy Elements

From Table I, Chapter 4, 540 16 inch glass balls will be required for the nine intermediate cables on each 9050 foot sublength. This amounts to \$26,000 per sublength or \$7.5 million for the entire 24 inch pipeline.

5.1.3e Intermediate Anchors

Using the 10¢/lb estimate for the tower anchors and the Table I results, the intermediate tower anchors are estimated to cost \$3.1 million for the entire 24 inch floating line.

5.1.3f Fittings

The fittings, slings for the pipeline attachment, etc., are estimated at \$1000/intermediate buoy station or \$2.9 million for the 24 inch pipeline.

5.1.3g Total Pipeline Material Costs

For the 24 inch pipeline the pipeline plus intermediate and secondary tower buoy and cable material costs total \$88.4 million.

5.1.4 Pipe and Intermediate Cable Installation Costs

The critical factor in the speed of laying out the pipeline, preparatory to pulling it down to the towers, is the welding rate (personal communication with Mr. Sam Small, Bechtel Corporation - see Appendix VI). It has been assumed here that the welding rate for a 30 inch line will be 3000 feet/day and 3600 feet/day for a 24 inch line. It is assumed that a lay barge and supporting vessels will cost \$50,000/day for all three sizes of pipeline considered. In addition, \$20,000/day must be added for the installation and supply barges required to install the intermediate cables. Allowing 20% down time because of bad weather and other delays, the cost for installing the 24 inch line is estimated to be \$63.3 million.

5.1.5 Safety Valves, Explosive Flanges and Instrumentation

There will be two safety valves at each tower station as well as the two explosive flanges to break off the broken pipe end in the event of pipe failure. These, together with their instrumentation and wiring are estimated at \$40,000 per tower (See personal interview with Mr. Sam Small, Bechtel Corporation, Appendix VI). The total estimated cost for the entire 24 inch pipeline is \$11.6 million. For the larger pipe sizes \$5000/tower/6 inch diameter increase is added to this figure.

5.1.6 The Bottom Mounted Pipe

Based upon \$15,000/inch diameter/mile of pipeline (See Appendix VI - interview with Mr. Sam Small, Bechtel Corporation), the ten miles of bottom mounted line will cost \$3.6 million for the 24 inch pipeline.

5.1.7 The Pumping Stations

The Capital Investment for the pumping stations is estimated at \$1.0 million for the buildings and \$200/HP of pumping power required. This variable investment is not included in the Investment figures shown in Table II, and will be accounted for later in the return on investment calculations.

5.1.8 The Total Investment

The total investment, exclusive of pumping station costs, for each of the three pipeline sizes and respective gas rates is shown in Table II. For the purposes of calculating return on investment, it is expected that it will require two years to construct the 400 MMCF/D rated pipeline, and three years for either the 800 MMCF/D or the 1200 MMCF/D rated lines. There will be no income during these periods, but the average investment during the construction period is approximately one half the total for each year of construction for each of the three pipelines

TABLE II
ESTIMATED INVESTMENT (\$ million)*

Item	Rate		
	400 MMSCF/D	800 MMSCF/D	1200 MMSCF/D
1) Tower Materials			
Buoys	4.9	5.1	5.2
Cables	8.1	9.8	12.6
Buoyancy Elements	10.6	13.8	17.5
Fittings	0.6	0.8	0.9
Anchors	<u>3.0</u>	<u>4.3</u>	<u>5.2</u>
Subtotal	27.2	33.8	41.4
2) Tower Installation	23.0	32.3	43.1
3) Pipeline Materials			
Pipe	39.2	93.8	119.9
Int. Buoys	28.8	31.7	34.6
Int. Cables	6.9	10.5	15.6
Cable Buoyancy	7.5	11.4	16.5
Int. Anchors	3.1	4.4	5.7
Fittings	<u>2.9</u>	<u>3.9</u>	<u>5.8</u>
Subtotal	88.4	155.7	198.1
4) Pipeline Installation	63.3	76.0	95.0
5) Safety Devices and Instrumentation	11.6	12.9	14.4
6) Bottom Mounted Pipeline	<u>3.6</u>	<u>4.5</u>	<u>5.4</u>
7) Subtotal	217.1	315.2	397.4
8) Other Charges and Contingencies (10%)	<u>21.7</u>	<u>31.5</u>	<u>39.7</u>
9) TOTAL	238.8	346.7	437.1

*The totals exclude the pumping station investment of \$500,000/site for the two sites plus \$200/HP of pumping capacity (personal communication with Mr. Charles Arnold, Bechtel Corporation).

considered. This investment and the interest and other charges are considered later.

5.2 ESTIMATED COSTS

5.2.1 Maintenance and Inspection Costs

The critical aspect of maintenance on marine pipelines is predicting the effects of corrosion. The cost estimates for cables on this pipeline have included the cost of completely coating the cables with plastic to reduce the corrosion possibilities. However, any breaks in the coating will cause "pin-hole" corrosion and failures will occur. Present experience with marine cables indicates a maximum life of between five and ten years (personal communication with Mr. M. H. Peterson, Naval Research Laboratory); these are the critical features in the structure's integrity. Bechtel Corporation reports indicate that corrosion of the pipeline is not a critical problem because pipelines already in the water have lasted more than twenty years. It is assumed that our pipeline will be coated with an anticorrosion and antifouling material similar to that now used on bottom mounted pipelines.

It is difficult to estimate any realistic maintenance cost for the pipeline; therefore, it is proposed that the return on investment picture be examined on the basis of

having to replace all of the cables over periods of ten years, fifteen years, and twenty years, respectively. Table III gives estimates of maintenance and inspection costs for each size pipeline depending upon whether a ten year, fifteen year, or twenty year life expectancy for the cables and towers is used. The maintenance figures in Table III are obtained by totaling the cost of all cables, fittings and anchors for each pipeline system, doubling the amount to account for reinstallation costs and then assuming ten, fifteen and twenty year life expectancy rates.

The inspection cost estimates have been determined by assuming the cost of three (one standby) lock-in, lock-out, diver submarines at \$5000/day including personnel and support vessels (personal communication with Perry Submarine Inc.). These submarines will patrol the line, continuously looking for corrosion, replacing fittings, etc. They cannot observe possible failure points at great depth, and these must be handled as they occur.

5.2.2 Insurance and Interest

It is assumed that the pipeline will be charged for self insurance in an amount equal to 1% of its total value per year to cover possible catastrophies that would utilize this sinking fund. This would allow for the costs of repairing a possible pipeline rupture which might involve

TABLE III

MAINTENANCE AND INSPECTION COSTS (\$000)

	Cost/Year of Operation		
	10 yr. life	15 yr. life	20 yr. life
400,000 MSCF/D			
Maintenance	5,000	3,800	2,500
Inspection	<u>2,000</u>	<u>2,000</u>	<u>2,000</u>
TOTAL	7,000	5,800	4,500
800,000 MSCF/D			
Maintenance	7,000	5,200	3,500
Inspection	<u>2,000</u>	<u>2,000</u>	<u>2,000</u>
TOTAL	9,000	7,200	5,500
1,200,000 MSCF/D			
Maintenance	9,000	6,800	4,500
Inspection	<u>2,000</u>	<u>2,000</u>	<u>2,000</u>
TOTAL	11,000	8,800	6,500

large losses of product and equipment, if not life. For example, the 400 MMCF/D rated line would be charged \$2.4 million per year self insurance in addition to interest and other fixed charges.

5.2.3 Other Fixed Costs

The other fixed costs for any particular pipeline are \$120,000/year fixed operating costs for the pumping stations (personal communication with Mr. Charles Arnold, Bechtel Corporation).

5.3 VARIABLE COSTS (Bechtel Corporation)

The only variable costs considered under the method of cost allocation used are gas consumption of 12 cu ft/HP/day for whatever HP is required at each pumping station and \$5/HP/year on the same basis. The gas at the input to the pipeline is assumed to cost \$0.10/MCF.

5.4 RETURN ON INVESTMENT

Appendix VI presents a computer program that computes the return on investment for each pipeline assuming ten, fifteen and twenty year life expectancies for each pipeline. For each life expectancy, the ten year

level of structure maintenance is adopted from Table III. Therefore, three different return rates are calculated for each size of pipeline for a given selling price for the gas.

In preparing this program, a present value approach to return on investment was taken with year 0 starting when the pipeline construction starts. The following assumptions were made:

- 1) The three sizes of pipeline require 2, 3 and 3 years to construct, respectively.
- 2) The rates of flow will be $Q/2$ for the first 3 years of operation, $3Q/4$ for the second 3 years of operation and Q (the ultimate rated capacity) for the remainder of the life of the pipeline.
- 3) The value of temperature, pressures, and the other physical parameters of pipe flow are those assumed in Appendix II.
- 4) The cost of gas at the Minorca pumping station is calculated by trial and error to achieve a cost equivalent to the cost to any other customer.
- 5) The cost of gas at the input to the pipeline is \$0.10/MCF.
- 6) The selling price of the gas has three possible levels; \$0.40/MCF, \$0.45/MCF and \$0.50/MCF.
- 7) The interest rate is 8%.

The results of applying this computer program analysis of the return on investment for the three sizes of pipelines at the three maintenance levels shown in Table III are shown in Table IV.

TABLE IV
RETURN ON INVESTMENT*

Flow Rate (MMSCF/D)	Selling Price of Gas (\$/MSCF)	Percent Return on Investment for Expected Pipeline Life of		
		10 Yrs.	15 Yrs.	20 Yrs.
400	0.40	Negative	Negative	9.5
	0.45	Negative	9.0	12.0
	0.50	Negative	12.0	14.5
800	0.40	Negative	11.5	13.5
	0.45	9.0	14.5	16.5
	0.50	12.5	17.5	19.0
1200	0.40	9.5	15.0	17.0
	0.45	13.5	18.0	20.0
	0.50	17.5	21.5	23.0

* The percent return is before allowing for any taxes, transit fees or depreciation. All calculations assume an 8% interest rate for calculating present value.

6. DISCUSSION

The findings of Chapter 4 and Chapter 5 permit several significant observations:

- 1) The stresses and motions in the towers of the pipeline can be made sufficiently small to meet the design criteria specified earlier in this investigation. The cables and buoys required are of practical sizes for handling at sea with present equipment.
- 2) Although the mid-points of the pipeline sublengths between towers move as much as 350 feet in the horizontal direction, the remainder of the pipe system can be held to the motion tolerances that have been specified. It is not possible, under the current conditions specified, to hold the horizontal motions of the pipe sublengths to significantly smaller variations. To do so would require shortening the pipe sublengths to less than 9050 feet. This shortening causes rapid increases in pipe tensions and reactions on the towers in the event of pipe failure. The reactions then are too large to be restrained by towers of a size that permits reliance on present state-of-the-art methods.
- 3) The resulting motions and stresses shown in Table I are for a constant-current profile of 0.3 feet per

second. It is apparent that any appreciable increase in the current profile over this value will result in stresses and motions that are much larger. Therefore, pipeline systems of our type may be feasible only in areas where the current velocity is low. In shallow water, where it will be possible to put the pipeline towers closer together, the larger currents could probably be handled with components of a size that could be handled by presently proven methods. However, these limits have not been studied in this investigation.

- 4) The capital investment required for each of the three pipeline sizes considered is about twice the investment for bottom-mounted pipelines recently installed in the Gulf Coast area of the United States (34). This much larger cost can be justified only by the fact that the line is traversing water depths averaging approximately 9,000 feet instead of a few hundred feet. However, even then the added cost can be justified only by economic evaluation against other possible means of achieving the same results.
- 5) While there are admittedly many guesses involved in the cost estimates which have led to the final return on investment figures presented in Table IV, the conservative assumptions made, and the consistent

effort made to rely upon only proven state-of-the-art methods of construction and installation, should mean that the estimates are conservative.

- 6) The return on investment calculations presented can be meaningful only in the light of experienced assessment of the risks involved. Even though every effort has been made to use a conservative approach, the risks are still admittedly large because this is an unproven system. Even the buoyant towers have been proven only in prototype form and there is no measure of their long-term durability in the face of sea water corrosion.
- 7) It is apparent from the return on investment estimates presented in Table IV that the highest capacity pipeline, 1200 MMSCF/D offers the most attractive return, regardless of the expected life. If the expected selling price of \$0.50/MSCF (personal communication with Mr. John Giese, Bechtel Corporation) can be realized, this largest line shows a pay out before taxes of less than six years even with the high maintenance estimates for only ten year expected cable life. This rate of return approaches that of an attractive oil producing play and exceeds that of most pipelines built on land. The higher rates of return shown for longer expected pipeline life, while more

attractive, are less determining in a feasibility decision because the element of risk for such a new venture is larger than these higher return rates reflect.

- 8) The estimated return results for the smallest capacity pipeline seem to rule out any consideration of building a line of this ultimate capacity for this location. Looping the line to increase its capacity later when the market develops to greater size as is often done for gas pipelines does not seem a feasible consideration here.
- 9) The sensitivity of estimated return on investment to selling price variations of only 20% probably also rules out consideration of the 30 inch diameter, 800 MMSCF/D capacity line also. Its best estimated pay out for a ten year expected life is more than eight years even before taxes on the conservative ten year expected life basis. This rate would leave only a two year profit period if the life expectancy period estimate proved correct.
- 10) Based upon the observations expressed in the above two paragraphs, the proposed pipeline seems to provide the alternative of all or nothing, i.e., build a large capacity pipeline for a large market or no pipeline at all. This last finding means that the potential

investor must take a very large capital risk or not take any risk at all. Although the estimated returns on the largest capacity line are certainly attractive, the projected investment of nearly \$0.5 billion required to try this new concept makes this particular location a questionable place to test this new concept.

Beyond these observations, it must be emphasized that this entire investigation has been a first-order feasibility study of the floating, anchored pipeline system. Further and more detailed analysis is clearly indicated, particularly in the area of bending stresses in the pipe near the connections between the pipeline and the buoyant towers. Also, although detailed computer results are not presented, there appears to be a relationship between the buoyancy allowed for the pipeline and its lateral excursion at the mid-points of the pipe sublengths between towers. It is to be noted in Table I that the larger pipelines with greater buoyancy per foot allowed have smaller lateral excursions. It is possible that some adjustment can be made in the buoyancy of the smaller diameter pipelines such that the lateral excursions will be smaller while the stresses in the pipeline and the reactions at the towers are not appreciably increased. Such optimization has not been within the scope of this investigation, but it is recommended for further study.

While every effort has been made to make the costs and investment figures realistic, it is believed that they are probably larger than necessary because of the desire to be conservative. It is recommended that these figures be carefully analyzed because significant reductions may be indicated. Such reductions would obviously produce more attractive return on investment estimates.

Finally, it seems prudent to consider testing this pipeline concept in a smaller-scale operation before seriously considering making the large capital investment that will be required for this Mediterranean crossing. Other possible opportunities for proving the concepts that have been evaluated in this investigation are transportation of natural gas or oil from the North Sea discoveries to Norway, a proposed crossing from Tunisia to Sicily (personal communication with Mr. Sam Small, Bechtel Corporation), or a gas pipeline from Sicily to the island of Malta. In all of these locations, the water depths are considerably shallower and the distances to be covered much shorter. On such a smaller-scale operation, the installation methods could be perfected, and the admittedly unpredictable effects of corrosion could be experienced and mastered at much lower levels of risk.

7. CONCLUSIONS

According to the results of this technical and economic analysis, it is feasible to construct a submerged, buoyant and anchored pipeline to cross the Mediterranean to serve the European market, providing a sufficient market and distribution system exists close enough to the French coast outlet. Obviously, there must be several qualifications to such a conclusion.

The first and perhaps most important qualification is that the necessary international diplomatic and economic arrangements must be satisfactorily concluded. These ramifications are not considered in this report.

Second, although the return on investment estimates appear to be attractive to potential investors, the magnitude of the undertaking and the uncertainties that must remain in any such major new development strongly indicate the desirability of proving these concepts in a smaller-scale operation before undertaking this ambitious project.

While this investigation has been in progress, major new developments have opened additional markets for liquified natural gas from North Africa in the United States. This development combined with reported agreements between European countries and the USSR for new sources of natural gas have undoubtedly affected the market and supply

situation to make it different from that assumed by this study. The effects of these new conditions must be carefully evaluated by any potential investor.

The high degree of sensitivity of pipe tensions and stresses to current forces clearly demands very detailed and thorough long term current surveys of any proposed location for such a floating, anchored pipeline. While the use of trimoored buoyant towers offers the possibility of being able to reduce pipe tension caused by current forces to workable levels for both installation and subsequent operation, there are probably locations where the water depths combined with high current forces will make this system impractical.

In the final analysis, however, the use of submerged buoyant and anchored pipelines to transport natural gas through the deep ocean appears to be extremely feasible and it is recommended that it be considered as a real alternative to transporting liquified natural gas by tanker wherever the potential market and distribution system is sufficiently large and concentrated.

BIBLIOGRAPHY

1. Sawyer, L. A., and Mitchell, W. H.: Tankers, Doubleday and Company, Inc., New York, 1967, pp. 78 and 152.
2. Burrows, G. H.: International Petroleum Industry, Vol. I, World/Europe/Middle East, International Petroleum Institute, Inc., New York, 1965, p. 5.
3. Author Unknown: "Energy in Western Europe", Report No. 367, Stanford Research Institute, Menlo Park, California, January, 1969.
4. Jensen, W. G.: Energy in Europe, University Printing House, Cambridge, England, 1967, 167 pages.
5. Author Unknown: International Petroleum Encyclopedia, Petroleum Publishing Company, Tulsa, Oklahoma, 1968, pp. 10-30.
6. Brewer, W. V., and Dixon, D. A.: "Influence of Lay Barge Motions on a Deep Water Pipeline Load under Tension", Proceedings, 1969 Offshore Technology Conference, Vol. II, Houston, Texas, May, 1969, pp. 23-36.

7. Langner, C. G.: "The articulated Stinger, A New Tool for Laying Offshore Pipeline", Proceedings, 1969 Offshore Technology Conference, Vol. II, Houston, Texas, May, 1969- pp. 37-47.
8. Ewing, M." "Some Results of Deep Ocean Drilling", Proceedings, 1969 Offshore Technology Conference, Vol. I, Houston, Texas, May, 1969, pp. 43-49.
9. Alldredge, L. R., and Fitz, J. C.: "Submerged Stabilized Platform", Deep Sea Research, June, 1964.
10. AMSOC Committee of the Division of Earth Sciences: "Experimental Drilling in Deep Water", Publication No. 914, National Academy of Sciences, 1961, pp. 51-65.
11. Hoerner, S. F." "Fluid Dynamic Drag", published by the author, 1958, pp. 3-1 to 3-28.
12. Kissinger, R., and Rupp, L. A." "Development of a Model Rudder Dynamometer", MS Thesis, Massachusetts Institute of Technology, 1943.
13. Kullenberg, B.: "On the Shape and the Length of the Cable during a Deep-Sea Traveling", Reports of the Swedish Deep-Sea Expedition, Vol. II, Zoology No. 2, 1951, pp. 31-44.

14. Lukasik, S. J., and Grosch, C. E.: "Pressure Velocity Correlations in Ocean Swell", Journal of Geophysical Research, Vol. 68, No. 20, Oct., 1963, pp. 5, 689-695, 699.
15. Marks, Wilbur: "The Application of Spectral Analysis and Statistics to Seakeeping", Research Bulletin No. 1-24, Society of Naval Architects and Marine Engineers, September, 1963.
16. Milgram, J. H.: "Studies on Making Wave Measurements in the Open Sea", Task NR 062-313, Report to the Department of the Navy, (Contract NONR-4082 (00), Block Associates, Inc.), Office of Naval Research, Washington, D.C., pp. 1-7.
17. Moskowitz, L.: "Estimates of the Power Spectra for Fully Developed Seas for Wind Speeds of 20 to 40 Knots", Laboratory Report No. 63-11, Department of Meteorology and Oceanography Geophysical Sciences, New York University, September, 1963, pp. 28-29.
18. Pode, L.: "Tables for Computing the Equilibrium Configuration of a Flexible Cable in a Uniform Stream", Report No. 687; The David Taylor Model Basin, Navy Department, March 1961.

19. Savage, G. H., and Sniffin, G. N.: "Analysis of the Motion of a Trimooored Buoy with Neutrally Buoyant Legs", Project Seaspider-Pacific, Tech. Report No. 104 to the Department of the Navy (Contract N00014-67-A-0158-004, Engineering Design and Analysis Laboratory, University of New Hampshire), Office of Naval Research, Washington, D. C., pp. 1-16, February, 1968.

20. Savage, G. H., and Hersey, J. B.: "Project SEASPIDER: The Design, Assembly, Construction and Sea Trials of a Trimooored Buoyant Structure with Neutrally Buoyant Legs to Provide a Near-Motionless Instrument Base for Oceanographic Research", Tech. Report No. 68-42 to the Department of the Navy (Contract NONR 4029(00), Woods Hole Oceanographic Institution), Office of Naval Research, Washington, D.C., June, 1968, unpublished manuscript.

21. Savage, G. H., and thirteen Co-Authors: "Scientific Sealab: The Design and Analysis of a Mobile Saturation Diving System for the National Oceanographic Community", Tech. Report No. 100 to the Department of the Navy, (Contract N00014-67-A-0158-005, Engineering Design and Analysis Laboratory, University of New Hampshire), Office of Naval Research, Washington, D.C.,

November, 1966.

22. Winger, J. G., Emerson, J. D., Gunning, G. D."
"Outlook for Energy in the United States", The Chase
Manhattan Bank, N.A., New York, October, 1968.
23. Skop, R. A., and O'Hara, G. J.: "The Static
Equilibrium Configuration of Cable Arrays by Use of
the Method of Imaginary Reactions", Naval Research
Laboratory, Washington, D.C. NRL Report 6819,
February 28, 1969.
24. Skop, R. A., and Kaplan, R. E.: "The Static
Configuration of a Trimooored Subsurface, Buoy-Cable
Array Acted on by Current-Induced Forces", Naval
Research Laboratory, Washington, D.C., NRL Report
6894, May 14, 1969.
25. Lamb, Horace: "Hydrodynamics", Dover Publication,
New York, Sixth Edition, 1932,
26. Roark, R. J.: "Formulas For Stress And Strain",
McGraw-Hill Book Company, Inc., New York and London,
Second Edition, 1943, pp. 271-272.
27. Pfluger, Alf: "Elementary Statics of Shells",
F. W. Dodge Corporation, New York, 1961.

28. Miller, Arthur R.: "Physical Oceanography of the Mediterranean Sea: A Discourse", Report to the International Physical Oceanography Committee for the Mediterranean Sea, Vol. XVII (3), 1963, pp. 857-871.
29. Lacombe, Henry: "Les Interactions Ocean-Atmosphere", *Atomes*, No. 268, September, 1969, Vol. 24, pp. 487-494.
30. Gonella, J., Eskenazi, G. and Fropo, J.: "Results of Measurements of Wind and Current by the Buoy Laboratory During 1964", Extract of Cahiers Oceanographiques, XIX, March 3, 1967, pp. 195-218.
31. Ippen, A. T., Editor: "Estuary and Coastline Hydrodynamics", McGraw Hill Book Company, Inc., New York, 1966, pp. 1-34, pp. 341-374.
32. Corell, R. W.: "Sensitivity Analysis of a Trimooored Buoy", Report to the U.S. Navy (Contract Noo014-67-A-0158-004), Office of Naval Research, Washington, D.C., March, 1969, unpublished manuscript.
33. Small, Sam. Bechtel Corporation, San Francisco, California: Personal Interview, Appendix VI.

34. O'Donnell, J. P.: "Pipeline Installation and Equipment Costs", The Oil and Gas Journal, August, 1969, The Petroleum Publishing Company, Tulsa, Oklahoma, pp. 145-156.

APPENDIX I

COMPUTER PROGRAMS TO COMPUTE
PIPELINE AND TOWER
CONFIGURATIONS AND STRESSES

APPENDIX I

The following computer programs show example outputs for the 400 MMSCF/D, 24 inch OD pipeline. The first program calculates the motions and stresses for one 9050 foot long sublength attached to a tower at each end. The sublength is divided into 100 lumping stations. Trial runs using only 50 lumping stations show less than 0.1% variation in the values of stresses and maximum motion. The components of external force determined for each end of the pipe sublength are the reactions to be placed on a tower to test its ability to withstand maximum possible loads.

The second program computes the motions and stresses in a tower for a 24 inch pipeline. Only 21 lumping stations per leg are used. Analysis of motions on such a trimoored tower by Paquette (personal communication with Dr. R. L. Paquette, General Motors Corporation) has shown no significant difference in the results using 40 stations versus 21 stations. The results include the stresses and motions of the first and last segment and the first and last station on each leg. These results have been used to make the decisions for component size and other data shown in Table II, Chapter 4. In addition to the results for the 24 inch pipeline towers, the results for the 30 inch and 36 inch pipeline towers are also shown at the program's end. The cable specification for these latter two tower sizes are omitted to save space.

```

C
C
C THE MOTIONS OF A BUOYANT, BUT ANCHORED PIPELINE THAT IS FIXED
C AT BOTH ENDS, RESTRAINED IN THE VERTICAL DIRECTION AT INTERVALS
C BETWEEN THE END POINTS, AND ACTED UPON BY THE EXTERNAL FORCES OF
C DRAG DUE TO CURRENT AND FORCES DUE TO BUOYANCY.
C THE PIPE IS ASSUMED TO BE ANCHORED SUFFICIENTLY BELOW THE SURFACE
C TO BE REMOVED FROM ALL FORCES DUE TO SURFACE WAVE ACTION.
C
C COMPUTER PROGRAM BY G. H. SAVAGE USING THE METHOD OF
C IMAGINARY REACTIONS ASSUMING SMALL MOTIONS SO CURRENT FORCE CONST.
C
C
C FDP = PIPE DRAG FORCE/FT IN LBS.
C FBP = PIPE BUOYANT FORCE/FT IN LBS.
C FXI,FYI,FZI = INITIAL GUESSES AT THE REACTIONS OF TOWER ON PIPE.
C LENG = THE UNSTRESSED LENGTH OF PIPE SUBLENGTH.
C N = NUMBER OF LUMPING STATIONS ON A PIPE SUBLENGTH
C XO,YO,ZO = COORDINATES AT ONE END OF PIPE SUBLENGTH.
C XN,YN,ZN = COORDINATES AT OTHER END OF PIPE SUBLENGTH.
C COMPE = ACCEPTABLE VALUE OF ERROR,E.
C
ISN 0002 REAL LENGO,LENG,L
ISN 0003 DIMENSION T(100),LENGO(100),FX(100),FY(100),FZ(100),RX(100),
111 RY(100),RZ(100),L(100),X(100),Y(100),Z(100)
ISN 0004 111 READ(5,1)FDP
ISN 0005 1 FORMAT(F10.2)
ISN 0006 IF(FDP.EQ.1.0)GO TO 110
ISN 0008 READ(5,2)FBP,FXI,FYI,FZI,LENG,N
ISN 0009 2 FORMAT(5F10.2,I3)
ISN 0010 READ(5,3)B,XO,YO,ZO,XN,YN,ZN
ISN 0011 3 FORMAT(F12.1,6F10.2)
ISN 0012 READ(5,4)COMPE
ISN 0013 4 FORMAT(F10.3)
C INITIALIZATION
ISN 0014 ICOUNT = 0
ISN 0015 LEAP = 1
ISN 0016 ITEST = 1
ISN 0017 DO 5 M = 1,N
ISN 0018 LENGO(M) = LENG/N
ISN 0019 5 CONTINUE
ISN 0020 M = N
ISN 0021 FX(M) = FXI
ISN 0022 FY(M) = FYI
ISN 0023 FZ(M) = FZI
ISN 0024 DELTA = ABS(1.5 * FZ(N))
ISN 0025 NX = N-1
ISN 0026 DO 6 M = 1,NX
ISN 0027 FX(M) = 0.0
ISN 0028 FY(M) = FDP*LENGO(M)
ISN 0029 FZ(M) = FBP*LENGO(M)
ISN 0030 6 CONTINUE
ISN 0031 DO 16 M = 10,NX,10
ISN 0032 FZ(M) = FZ(M) - FBP*10. * LENGO(M)
ISN 0033 FY(M) = FY(M) -500.
ISN 0034 16 CONTINUE

```

```

ISN 0035      SUMX = 0.0
ISN 0036      SUMY = 0.0
ISN 0037      SUMZ = 0.0
ISN 0038      100 DO 177 M = 1,N
ISN 0039      DO 178 K = M,N
ISN 0040      SUMX = SUMX + FX(K)
ISN 0041      SUMY = SUMY + FY(K)
ISN 0042      SUMZ = SUMZ + FZ(K)
ISN 0043      178 CONTINUE
ISN 0044      RX(M) = SUMX
ISN 0045      RY(M) = SUMY
ISN 0046      RZ(M) = SUMZ
ISN 0047      SUMX = 0.0
ISN 0048      SUMY = 0.0
ISN 0049      SUMZ = 0.0
ISN 0050      177 CONTINUE
ISN 0051      DO 8 M = 1,N
ISN 0052      T(M) = SQRT(RX(M)**2 + RY(M)**2 + RZ(M)**2)
ISN 0053      L(M) = LENGO(M)*(1. + T(M)/8)
ISN 0054      8 CONTINUE
ISN 0055      DO 9 M = 1,N
ISN 0056      GO TO (10,11),M
ISN 0057      11 X(M) = (L(M)/T(M))*RX(M) + X(M-1)
ISN 0058      Y(M) = (L(M)/T(M))*RY(M) + Y(M-1)
ISN 0059      Z(M) = (L(M)/T(M))*RZ(M) + Z(M-1)
ISN 0060      GO TO 9
ISN 0061      10 X(M) = (L(M)/T(M))*RX(M) + X0
ISN 0062      Y(M) = (L(M)/T(M))*RY(M) + Y0
ISN 0063      Z(M) = (L(M)/T(M))*RZ(M) + Z0
ISN 0064      9 CONTINUE
ISN 0065      E = (XN-X(N))**2+(YN-Y(N))**2+(ZN-Z(N))**2
ISN 0066      ICOUNT = ICOUNT + 1
ISN 0067      IF(E.GT.COMPE)GO TO(19,50,15),LEAP
ISN 0069      121 WRITE(6,69)
ISN 0070      69 FORMAT('1',10X,'REACTIONS AND COORDINATE AT KEY POINTS')
ISN 0071      WRITE(6,71)ICOUNT,E
ISN 0072      71 FORMAT(10X,'ICOUNT=',I3,10X 'E=',E16.9)
ISN 0073      WRITE(6,58)ITEST,E
ISN 0074      58 FORMAT(10X,'ITEST=',I2,5X,'E=',E16.9)
ISN 0075      WRITE(6,773)DELTA
ISN 0076      773 FORMAT(10X,'DELTA=',E16.9)
ISN 0077      WRITE(6,144)B,XN
ISN 0078      144 FORMAT(10X,'B=',E16.9,10X,'XN=',E16.9)

```

```

C
C   THE PROGRAM NOW PRINTS THE COORDINATES OF EACH LUMPING STATION
C   THE STRESSES IN EACH SEGMENT, AND THE EXTERNAL FORCES AT EACH STA..
C   THE EXTERNAL FORCES AT EACH END ARE THE REACTIONS OF THE PIPE
C   SUBLLENGTH ON THE TOWERS AT EACH END. THESE ARE THE FXPIP,FYPIP,
C   FZPIP TO BE USED AS DATA IN THE NEXT PROGRAM TO OBTAIN THE MOTIONS
C   AND THE STRESSES IN THE TOWERS TO DETERMINE REQUIRED TOWER BUOY
C   AND CABLE AND ANCHOR SIZES.
C

```

```

ISN 0079      DO 77 M = 1,N,1
ISN 0080      WRITE(6,80)M
ISN 0081      80 FORMAT(/,10X,'SEGMENT NO=',I2)

```

```

ISN 0082      WRITE(6,78)X(M),Y(M),Z(M)
ISN 0083      78 FORMAT(10X,'X(M)=',E16.9,10X,'Y(M)=',E16.9,10X,'Z(M)=',E16.9)
ISN 0084      WRITE(6,578)FX(M),FY(M),FZ(M)
ISN 0085      578 FORMAT(10X,'FX=',E16.9,10X,'FY=',E16.9,10X,'FZ=',E16.9)
ISN 0086      WRITE(6,179)RX(M),RY(M),RZ(M)
ISN 0087      179 FORMAT(10X,'RX=',E16.9,10X,'RY=',E16.9,10X,'RZ=',E16.9)
ISN 0088      77 CONTINUE
ISN 0089      GO TO 111
ISN 0090      19 LEAP = 2
ISN 0091      20 EP = E
ISN 0092      XP = X(N)
ISN 0093      YP = Y(N)
ISN 0094      ZP = Z(N)
ISN 0095      FXP = FX(N)
ISN 0096      FYP = FY(N)
ISN 0097      FZP = FZ(N)
ISN 0098      GO TO 12
ISN 0099      50 IF(ABS(YN-Y(N)).GE.COMPE.OR.ABS(ZN-Z(N)).GE.COMPE)GO TO 1500

```

```

C
C   THIS APPROXIMATION OF FX USES NEWTON'S METHOD TO ACCELERATE
C   CONVERGENCE TO AN ACCEPTABLE ERROR AFTER DELTA HAS BECOME SMALL IN
C   ORDER TO REDUCE THE Y AND Z ERROR.

```

```

ISN 0101      ITEST = ITEST + 1
ISN 0102      IF(X(N).EQ.XP)GO TO 1500
ISN 0104      DELFXP = ((FX(N)-FXP)/(X(N)-XP))*(XN-X(N))
ISN 0105      FXP = FX(N)
ISN 0106      FX(N) = FX(N) + DELFXP
ISN 0107      XP = X(N)
ISN 0108      GO TO 100
ISN 0109      1500 IF(E.LT.EP)GO TO 20
ISN 0111      DELTA = DELTA/2.
ISN 0112      12 DE = DELTA/SQRT(EP)
ISN 0113      FX(N) = FXP + (XN-X(N))*DE
ISN 0114      FY(N) = FYP + (YN-Y(N))*DE
ISN 0115      FZ(N) = FZP + (ZN-Z(N))*DE
ISN 0116      IF(FX(N).NE.FXP.OR.FY(N).NE.FYP.OR.FZ(N).NE.FZP)GO TO 100
ISN 0118      LEAP = 3
ISN 0119      GO TO 100
ISN 0120      15 WRITE(6,122)
ISN 0121      122 FORMAT(10X,'THE PROBLEM HAS NOT BEEN SOLVED'/)
ISN 0122      GO TO 121
ISN 0123      110 CONTINUE
ISN 0124      RETURN
ISN 0125      END

```

ADDCNS FOR EXTERNAL REFERENCES

REACTIONS AND COORDINATE AT KEY POINTS

ICOUNT= 23 E= 0.274605490E-01
 ITEST= 4 E= 0.274605490E-01
 DELTA= 0.585937500E 02
 B= 0.22000000E 10 XN= 0.900000000E 04

SEGMENT NO= 1
 X(M)= 0.892323456E 02 Y(M)=-0.127795048E 02 Z(M)= 0.804241657E 01
 FX= 0.0 FY=-0.199099884E 02 FZ= 0.45250000E 03
 RX= 0.225914727E 05 RY=-0.323546143E 04 RZ= 0.203614526E 04

SEGMENT NO= 2
 X(M)= 0.178615173E 03 Y(M)=-0.255017853E 02 Z(M)= 0.143080854E 02
 FX= 0.0 FY=-0.199099884E 02 FZ= 0.45250000E 03
 RX= 0.225914727E 05 RY=-0.321555127E 04 RZ= 0.158364526E 04

SEGMENT NO= 3
 X(M)= 0.268114014E 03 Y(M)=-0.381616974E 02 Z(M)= 0.187892456E 02
 FX= 0.0 FY=-0.199099884E 02 FZ= 0.45250000E 03
 RX= 0.225914727E 05 RY=-0.319564111E 04 RZ= 0.113114526E 04

SEGMENT NO= 4
 X(M)= 0.357694092E 03 Y(M)=-0.507541504E 02 Z(M)= 0.214802094E 02
 FX= 0.0 FY=-0.199099884E 02 FZ= 0.45250000E 03
 RX= 0.225914727E 05 RY=-0.317573096E 04 RZ= 0.678645264E 03

SEGMENT NO= 5
 X(M)= 0.447320068E 03 Y(M)=-0.632740936E 02 Z(M)= 0.223773804E 02
 FX= 0.0 FY=-0.199099884E 02 FZ= 0.45250000E 03
 RX= 0.225914727E 05 RY=-0.315582080E 04 RZ= 0.226145264E 03

SEGMENT NO= 6
 X(M)= 0.536957031E 03 Y(M)=-0.757165680E 02 Z(M)= 0.214792633E 02
 FX= 0.0 FY=-0.199099884E 02 FZ= 0.45250000E 03
 RX= 0.225914727E 05 RY=-0.313591455E 04 RZ=-0.226354736E 04

SEGMENT NO= 7
 X(M)= 0.626569336E 03 Y(M)=-0.880766754E 02 Z(M)= 0.187864838E 02
 FX= 0.0 FY=-0.199099884E 02 FZ= 0.45250000E 03
 RX= 0.225914727E 05 RY=-0.311600830E 04 RZ=-0.678854736E 03

SEGMENT NO= 8
 X(M)= 0.716121826E 03 Y(M)=-0.100349609E 03 Z(M)= 0.143017950E 02
 FX= 0.0 FY=-0.199099884E 02 FZ= 0.45250000E 03
 RX= 0.225914727E 05 RY=-0.309610205E 04 RZ=-0.113135474E 04

SEGMENT NO= 9
 X(M)= 0.805579346E 03 Y(M)=-0.112530731E 03 Z(M)= 0.803004551E 01
 FX= 0.0 FY=-0.199099884E 02 FZ= 0.45250000E 03
 RX= 0.225914727E 05 RY=-0.307619580E 04 RZ=-0.158385474E 04

SEGMENT NO=10
 X(M)= 0.894907471E 03 Y(M)=-0.124615494E 03 Z(M)=-0.218391418E-01
 FX= 0.0 FY=-0.519909912E 03 FZ=-0.40725000E 04
 RX= 0.225914727E 05 RY=-0.305628955E 04 RZ=-0.203635474E 04

SEGMENT NO=11
 X(M)= 0.984484619E 03 Y(M)=-0.134672531E 03 Z(M)= 0.805164140E 01
 FX= 0.0 FY=-0.199099884E 02 FZ= 0.45250000E 03
 RX= 0.225914727E 05 RY=-0.253639893E 04 RZ= 0.203614526E 04

SEGMENT NO=12			
X(M)= 0.107421143E 04	Y(M)=-0.144667313E 03	Z(M)= 0.143414593E 02	
FX= 0.0	FV=-0.199099884E 02	FZ= 0.452500000E 03	
RX= 0.225914727E 05	RY=-0.251648877E 04	PZ= 0.158364526E 04	
SEGMENT NO=13			
X(M)= 0.116405322E 04	Y(M)=-0.154595718E 03	Z(M)= 0.188397980E 02	
FX= 0.0	FV=-0.199099884E 02	FZ= 0.452500000E 03	
RX= 0.225914727E 05	RY=-0.249657861E 04	PZ= 0.113114526E 04	
SEGMENT NO=14			
X(M)= 0.125397485E 04	Y(M)=-0.164453705E 03	Z(M)= 0.215410300E 02	
FX= 0.0	FV=-0.199099884E 02	FZ= 0.452500000E 03	
RX= 0.225914727E 05	RY=-0.247666846E 04	RZ= 0.678645264E 03	
SEGMENT NO=15			
X(M)= 0.134394067E 04	Y(M)=-0.174237244E 03	Z(M)= 0.224416046E 02	
FX= 0.0	FV=-0.199099884E 02	FZ= 0.452500000E 03	
RX= 0.225914727E 05	RY=-0.245675830E 04	PZ= 0.226145264E 03	
SEGMENT NO=16			
X(M)= 0.143391504E 04	Y(M)=-0.183942429E 03	Z(M)= 0.215401001E 02	
FX= 0.0	FV=-0.199099884E 02	FZ= 0.452500000E 03	
RX= 0.225914727E 05	RY=-0.243685205E 04	PZ= -0.226354736E 03	
SEGMENT NO=17			
X(M)= 0.152386206E 04	Y(M)=-0.193565414E 03	Z(M)= 0.188372498E 02	
FX= 0.0	FV=-0.199099884E 02	FZ= 0.452500000E 03	
RX= 0.225914727E 05	RY=-0.241694580E 04	PZ= -0.6788954736E 03	
SEGMENT NO=18			
X(M)= 0.161374634E 04	Y(M)=-0.203102478E 03	Z(M)= 0.143359470E 02	
FX= 0.0	FV=-0.199099884E 02	FZ= 0.452500000E 03	
RX= 0.225914727E 05	RY=-0.239703955E 04	PZ= -0.113135474E 04	
SEGMENT NO=19			
X(M)= 0.170353223E 04	Y(M)=-0.212549988E 03	Z(M)= 0.804118633E 01	
FX= 0.0	FV=-0.199099884E 02	FZ= 0.452500000E 03	
RX= 0.225914727E 05	RY=-0.237713330E 04	RZ= -0.158385474E 04	
SEGMENT NO=20			
X(M)= 0.179318481E 04	Y(M)=-0.221904465E 03	Z(M)=-0.399417877E -01	
FX= 0.0	FV=-0.51909912E 03	FZ=-0.407250000E 04	
RX= 0.225914727E 05	RY=-0.235722705E 04	PZ=-0.203635474E 04	
SEGMENT NO=21			
X(M)= 0.188302588E 04	Y(M)=-0.229211136E 03	Z(M)= 0.405735397E 01	
FX= 0.0	FV=-0.199099884E 02	FZ= 0.452500000E 03	
PX= 0.225914727E 05	RY=-0.183733643E 04	RZ= 0.203614526E 04	
SEGMENT NO=22			
X(M)= 0.197301587E 04	Y(M)=-0.236450592E 03	Z(M)= 0.143655882E 02	
FX= 0.0	FV=-0.199099884E 02	FZ= 0.452500000E 03	
RX= 0.225914727E 05	RY=-0.181742627E 04	RZ= 0.158364526E 04	
SEGMENT NO=23			
X(M)= 0.206311938E 04	Y(M)=-0.243619781E 03	Z(M)= 0.198770294E 02	
FX= 0.0	FV=-0.199099884E 02	FZ= 0.452500000E 03	
RX= 0.225914727E 05	RY=-0.179751611E 04	PZ= 0.113114526E 04	
SEGMENT NO=24			

X(M)= 0.215330078E 04 FX= 0.0 RX= 0.225914727E 05	Y(M)=-0.250715698E 03 FY=-0.199099884E 02 RY=-0.177760596E 04	Z(M)= 0.215860596E 02 FZ= 0.452500000E 03 RZ= 0.678645264E 03
SEGMENT NO=25 X(M)= 0.224352441E 04 FX= 0.0 RX= 0.225914727E 05	Y(M)=-0.257735352E 03 FY=-0.199099884E 02 RY=-0.175769580E 04	Z(M)= 0.224892120E 02 FZ= 0.452500000E 03 RZ= 0.226145264E 03
SEGMENT NO=26 X(M)= 0.233375415E 04 FX= 0.0 RX= 0.225914727E 05	Y(M)=-0.264676025E 03 FY=-0.199099884E 02 RY=-0.173778955E 04	Z(M)= 0.215851440E 02 FZ= 0.452500000E 03 RZ=-0.226354736E 03
SEGMENT NO=27 X(M)= 0.242395386E 04 FX= 0.0 RX= 0.225914727E 05	Y(M)=-0.271534912E 03 FY=-0.199099884E 02 RY=-0.171788330E 04	Z(M)= 0.188747101E 02 FZ= 0.452500000E 03 RZ=-0.678854736E 03
SEGMENT NO=28 X(M)= 0.251408789E 04 FX= 0.0 RX= 0.225914727E 05	Y(M)=-0.278309326E 03 FY=-0.199099884E 02 RY=-0.169797705E 04	Z(M)= 0.143609018E 02 FZ= 0.452500000E 03 RZ=-0.113135474E 04
SEGMENT NO=29 X(M)= 0.260412012E 04 FX= 0.0 RX= 0.225914727E 05	Y(M)=-0.284996826E 03 FY=-0.199099884E 02 RY=-0.167807080E 04	Z(M)= 0.804885960E 01 FZ= 0.452500000E 03 RZ=-0.158385474E 04
SEGMENT NO=30 X(M)= 0.269401563E 04 FX= 0.0 RX= 0.225914727E 05	Y(M)=-0.291594727E 03 FY=-0.519909912E 03 RY=-0.165816455E 04	Z(M)=-0.541620255E-01 FZ=-0.407250000E 04 RZ=-0.203635474E 04
SEGMENT NO=31 X(M)= 0.278403760E 04 FX= 0.0 RX= 0.225914727E 05	Y(M)=-0.296130371E 03 FY=-0.199099884E 02 RY=-0.113827393E 04	Z(M)= 0.805944157E 01 FZ= 0.452500000E 03 RZ= 0.203614526E 04
SEGMENT NO=32 X(M)= 0.287420703E 04 FX= 0.0 RX= 0.225914727E 05	Y(M)=-0.300593094E 03 FY=-0.199099884E 02 RY=-0.111836377E 04	Z(M)= 0.143802538E 02 FZ= 0.452500000E 03 RZ= 0.158364526E 04
SEGMENT NO=33 X(M)= 0.296448804E 04 FX= 0.0 RX= 0.225914727E 05	Y(M)=-0.304983643E 03 FY=-0.199099884E 02 RY=-0.109845361E 04	Z(M)= 0.189005890E 02 FZ= 0.452500000E 03 RZ= 0.113114526E 04
SEGMENT NO=34 X(M)= 0.305484521E 04 FX= 0.0 RX= 0.225914727E 05	Y(M)=-0.309297363E 03 FY=-0.199099884E 02 RY=-0.107854346E 04	Z(M)= 0.216148987E 02 FZ= 0.452500000E 03 RZ= 0.678645264E 03
SEGMENT NO=35 X(M)= 0.314524219E 04 FX= 0.0 RX= 0.225914727E 05	Y(M)=-0.313533203E 03 FY=-0.199099884E 02 RY=-0.105863330E 04	Z(M)= 0.225197906E 02 FZ= 0.452500000E 03 RZ= 0.226145264E 03
SEGMENT NO=36 X(M)= 0.323564282E 04	Y(M)=-0.317689697E 03	Z(M)= 0.216140137E 02

FX= 0.0			FZ= 0.45250000E 03
RX= 0.225914727E 05			R7=-0.226354736F 03
SEGMENT NO=37			
X(M)= 0.332601099E 04	Y(M)=-0.321764893E 03	Z(M)= 0.188985138F 02	
FX= 0.0	FY=-0.199099884E 02	FZ= 0.45250000E 03	
RX= 0.225914727E 05	RY=-0.101882080F 04	PZ=-0.678854736E 03	
SEGMENT NO=38			
X(M)= 0.341631055E 04	Y(M)=-0.325757568E 03	Z(M)= 0.143764153F 02	
FX= 0.0	FY=-0.199099884E 02	FZ= 0.45250000E 03	
RX= 0.225914727E 05	RY=-0.999914551E 03	PZ=-0.113135474E 04	
SEGMENT NO=39			
X(M)= 0.350650537E 04	Y(M)=-0.329666016E 03	Z(M)= 0.805297375E 01	
FX= 0.0	FY=-0.199099884E 02	FZ= 0.45250000E 03	
RX= 0.225914727E 05	RY=-0.979008301E 03	P7=-0.158385474F 04	
SEGMENT NO=40			
X(M)= 0.359656030E 04	Y(M)=-0.333489014E 03	Z(M)=-0.644159317F-01	
FX= 0.0	FY=-0.519909912E 03	FZ=-0.407250000E 04	
RX= 0.225914727E 05	RY=-0.959102051E 03	PZ=-0.203614526F 04	
SEGMENT NO=41			
X(M)= 0.368667871E 04	Y(M)=-0.335240967E 03	Z(M)= 0.805788040F 01	
FX= 0.0	FY=-0.199099884E 02	FZ= 0.45250000E 03	
RX= 0.225914727E 05	RY=-0.439209229E 03	P7= 0.203614526F 04	
SEGMENT NO=42			
X(M)= 0.377694238E 04	Y(M)=-0.336916260E 03	Z(M)= 0.143853054E 02	
FX= 0.0	FY=-0.199099884E 02	FZ= 0.45250000E 03	
RX= 0.225914727E 05	RY=-0.419299316F 03	PZ= 0.158364526E 04	
SEGMENT NO=43			
X(M)= 0.386731567E 04	Y(M)=-0.338513916E 03	Z(M)= 0.149102631E 02	
FX= 0.0	FY=-0.199099884E 02	FZ= 0.45250000E 03	
RX= 0.225914727E 05	RY=-0.399389404E 03	P7= 0.113114526E 04	
SEGMENT NO=44			
X(M)= 0.395776294E 04	Y(M)=-0.340032959E 03	Z(M)= 0.216272888F 02	
FX= 0.0	FY=-0.199099884E 02	FZ= 0.45250000E 03	
RX= 0.225914727E 05	RY=-0.379479248E 03	PZ= 0.678645264E 03	
SEGMENT NO=45			
X(M)= 0.404824780E 04	Y(M)=-0.341472900E 03	Z(M)= 0.225330505E 02	
FX= 0.0	FY=-0.199099884E 02	FZ= 0.45250000E 03	
RX= 0.225914727E 05	RY=-0.359569336E 03	P7= 0.226145264E 03	
SEGMENT NO=46			
X(M)= 0.413873047E 04	Y(M)=-0.342833252E 03	Z(M)= 0.216264191F 02	
FX= 0.0	FY=-0.199099884E 02	FZ= 0.45250000E 03	
RX= 0.225914727E 05	RY=-0.339659424E 03	PZ=-0.226354736E 03	
SEGMENT NO=47			
X(M)= 0.422917969E 04	Y(M)=-0.344113281F 03	Z(M)= 0.189084320F 02	
FX= 0.0	FY=-0.199099884E 02	FZ= 0.45250000E 03	
RX= 0.225914727E 05	RY=-0.319749268E 03	PZ=-0.678854736E 03	
SEGMENT NO=48			
X(M)= 0.431955859E 04	Y(M)=-0.345312744F 03	Z(M)= 0.143823261E 02	
FX= 0.0	FY=-0.199099884E 02	FZ= 0.45250000E 03	

RX= 0.225914727E 05
 SEGMENT NO=49
 X(M)= 0.440982813E 04
 FX= 0.0
 RX= 0.225914727E 05
 SEGMENT NO=50
 X(M)= 0.449995703E 04
 FX= 0.0
 RX= 0.225914727E 05
 SEGMENT NO=51
 X(M)= 0.459008594E 04
 FX= 0.0
 RX= 0.225914727E 05
 SEGMENT NO=52
 X(M)= 0.468035547E 04
 FX= 0.0
 RX= 0.225914727E 05
 SEGMENT NO=53
 X(M)= 0.477073438E 04
 FX= 0.0
 RX= 0.225914727E 05
 SEGMENT NO=54
 X(M)= 0.486118359E 04
 FX= 0.0
 RX= 0.225914727E 05
 SEGMENT NO=55
 X(M)= 0.495166797E 04
 FX= 0.0
 RX= 0.225914727E 05
 SEGMENT NO=56
 X(M)= 0.504215234E 04
 FX= 0.0
 RX= 0.225914727E 05
 SEGMENT NO=57
 X(M)= 0.513255766E 04
 FX= 0.0
 RX= 0.225914727E 05
 SEGMENT NO=58
 X(M)= 0.522296875E 04
 FX= 0.0
 RX= 0.225914727E 05
 SEGMENT NO=59
 X(M)= 0.531323047E 04
 FX= 0.0
 RX= 0.225914727E 05
 SEGMENT NO=60
 X(M)= 0.540334766E 04
 FX= 0.0
 RX= 0.225914727E 05

RY=-0.299839355E 03
 Y(M)=-0.346431152E 03
 FY=-0.199099884E 02
 RY=-0.279929443E 03
 Y(M)=-0.347468506E 03
 FY=-0.519909912E 03
 RY=-0.260019531E 03
 Y(M)=-0.346431641E 03
 FY=-0.199099884E 02
 RY= 0.259889893E 03
 Y(M)=-0.345313477E 03
 FY=-0.199099884E 02
 RY= 0.279799805E 03
 Y(M)=-0.344114258E 03
 FY=-0.199099884E 02
 RY= 0.299709717E 03
 Y(M)=-0.342834473E 03
 FY=-0.199099884E 02
 RY= 0.319619873E 03
 Y(M)=-0.341474365E 03
 FY=-0.199099884E 02
 RY= 0.339529785E 03
 Y(M)=-0.340034668E 03
 FY=-0.199099884E 02
 RY= 0.359439697E 03
 Y(M)=-0.338515869E 03
 FY=-0.199099884E 02
 RY= 0.379349854E 03
 Y(M)=-0.336918701E 03
 FY=-0.199099884E 02
 RY= 0.399259766E 03
 Y(M)=-0.335243896E 03
 FY=-0.199099884E 02
 RY= 0.419169678E 03
 Y(M)=-0.333492188E 03
 FY=-0.519909912E 03
 RY= 0.439079590E 03

RZ=-0.113135474E 04
 Z(M)= 0.805346775E 01
 FZ= 0.452500000E 03
 RZ=-0.158385474E 04
 Z(M)=-0.706424713E-01
 FZ=-0.407250000E 04
 PZ=-0.203635474E 04
 Z(M)= 0.805263996E 01
 FZ= 0.452500000E 03
 PZ= 0.203614526E 04
 Z(M)= 0.143806667E 02
 FZ= 0.452500000E 03
 RZ= 0.158364526E 04
 Z(M)= 0.149059296E 02
 FZ= 0.452500000E 03
 RZ= 0.113114526E 04
 Z(M)= 0.216230621E 02
 FZ= 0.452500000E 03
 RZ= 0.678645264E 03
 Z(M)= 0.225288391E 02
 FZ= 0.452500000E 03
 PZ= 0.226145264E 03
 Z(M)= 0.216222222E 02
 FZ= 0.452500000E 03
 PZ=-0.226354736E 03
 Z(M)= 0.143785591E 02
 FZ= 0.452500000E 03
 PZ=-0.113135474E 04
 Z(M)= 0.805029678E 01
 FZ= 0.452500000E 03
 RZ=-0.158385474E 04
 Z(M)=-0.728273392E-01
 FZ=-0.407250000E 04
 PZ=-0.203635474E 04

SEGMENT NO=61			
X(M)= 0.549340234E 04	Y(M)=-0.329669434E 03	Z(M)= 0.804374218F 01	
FX= 0.0	FY=-0.199099884E 02	FZ= 0.45250000E 03	
FX= 0.0	RY= 0.958989014E 03	RZ= 0.203614526E 04	
SEGMENT NO=62			
X(M)= 0.558359375E 04	Y(M)=-0.325761230E 03	Z(M)= 0.143663473E 02	
FX= 0.0	FY=-0.199099884E 02	FZ= 0.45250000E 03	
FX= 0.0	RY= 0.978898926E 03	RZ= 0.158364526F 04	
SEGMENT NO=63			
X(M)= 0.567389063E 04	Y(M)=-0.321768799E 03	Z(M)= 0.18887603RE 02	
FX= 0.0	FY=-0.199099884E 02	FZ= 0.45250000E 03	
FX= 0.0	RY= 0.998808838E 03	PZ= 0.113114526E 04	
SEGMENT NO=64			
X(M)= 0.576425781E 04	Y(M)=-0.317693604E 03	Z(M)= 0.216022491F 02	
FX= 0.0	FY=-0.199099884E 02	FZ= 0.45250000E 03	
FX= 0.0	RY= 0.101871899E 04	RZ= 0.678645264E 03	
SEGMENT NO=65			
X(M)= 0.585465625E 04	Y(M)=-0.313537354E 03	Z(M)= 0.225071716E 02	
FX= 0.0	FY=-0.199099884E 02	FZ= 0.45250000E 03	
FX= 0.0	RY= 0.103862891E 04	RZ= 0.226145264E 03	
SEGMENT NO=66			
X(M)= 0.594505078E 04	Y(M)=-0.309301514E 03	Z(M)= 0.216014404F 07	
FX= 0.0	FY=-0.199099884E 02	FZ= 0.45250000E 03	
FX= 0.0	RY= 0.105853882E 04	RZ=-0.226354736E 03	
SEGMENT NO=67			
X(M)= 0.603540625E 04	Y(M)=-0.304988037E 03	Z(M)= 0.188862762E 02	
FX= 0.0	FY=-0.199099884E 02	FZ= 0.45250000E 03	
FX= 0.0	RY= 0.107844897E 04	PZ=-0.678854736E 03	
SEGMENT NO=68			
X(M)= 0.612568359E 04	Y(M)=-0.300598633E 03	Z(M)= 0.143650970E 02	
FX= 0.0	FY=-0.199099884E 02	FZ= 0.45250000E 03	
FX= 0.0	RY= 0.109835889E 04	RZ=-0.113135474E 04	
SEGMENT NO=69			
X(M)= 0.621585156E 04	Y(M)=-0.296135254E 03	Z(M)= 0.804345512E 01	
FX= 0.0	FY=-0.199099884E 02	FZ= 0.45250000E 03	
FX= 0.0	RY= 0.111826880E 04	RZ=-0.158385474E 04	
SEGMENT NO=70			
X(M)= 0.630587109E 04	Y(M)=-0.291599854E 03	Z(M)=-0.709829330F-01	
FX= 0.0	FY=-0.519909912E 03	FZ=-0.40725000E 04	
FX= 0.0	RY= 0.113817871E 04	RZ=-0.203635474E 04	
SEGMENT NO=71			
X(M)= 0.639576563E 04	Y(M)=-0.285001953E 03	Z(M)= 0.803121281E 01	
FX= 0.0	FY=-0.199099884E 02	FZ= 0.45250000E 03	
FX= 0.0	RY= 0.165808813E 04	RZ= 0.203614526E 04	
SEGMENT NO=72			
X(M)= 0.648579688E 04	Y(M)=-0.278314697E 03	Z(M)= 0.143424263F 02	
FX= 0.0	FY=-0.199099884E 02	FZ= 0.45250000E 03	
FX= 0.0	RY= 0.167799805E 04	RZ= 0.158364526E 04	

SEGMENT NO=73
 X(M)= 0.657592969E 04
 FX= 0.0
 RX= 0.225914727E 05

 Z(M)= 0.188553925E 02
 FZ= 0.452500000E 03
 PZ= 0.113114526E 04

 SEGMENT NO=74
 X(M)= 0.666612891E 04
 FX= 0.0
 RX= 0.225914727E 05

 Z(M)= 0.215649719E 02
 FZ= 0.452500000E 03
 RZ= 0.678645264E 03

 SEGMENT NO=75
 X(M)= 0.675635547E 04
 FX= 0.0
 RX= 0.225914727E 05

 Z(M)= 0.224581854E 02
 FZ= 0.452500000E 03
 RZ= 0.226145264E 03

 SEGMENT NO=76
 X(M)= 0.684657813E 04
 FX= 0.0
 RX= 0.225914727E 05

 Z(M)= 0.215641785E 02
 FZ= 0.452500000E 03
 PZ=-0.226394736E 03

 SEGMENT NO=77
 X(M)= 0.693675781E 04
 FX= 0.0
 RX= 0.225914727E 05

 Z(M)= 0.188542938E 02
 FZ= 0.452500000E 03
 PZ=-0.678854736E 03

 SEGMENT NO=78
 X(M)= 0.702685938E 04
 FX= 0.0
 RX= 0.225914727E 05

 Z(M)= 0.143420115E 02
 FZ= 0.452500000E 03
 RZ=-0.113135474E 04

 SEGMENT NO=79
 X(M)= 0.711684766E 04
 FX= 0.0
 RX= 0.225914727E 05

 Z(M)= 0.803294849E 01
 FZ= 0.452500000E 03
 RZ=-0.158385474E 04

 SEGMENT NO=80
 X(M)= 0.720669750E 04
 FX= 0.0
 RX= 0.225914727E 05

 Z(M)= -0.651721954E-01
 FZ=-0.407250000E 04
 PZ=-0.203635474E 04

 SEGMENT NO=81
 X(M)= 0.729633984E 04
 FX= 0.0
 RX= 0.225914727E 05

 Z(M)= 0.801513290E 01
 FZ= 0.452500000E 03
 RZ= 0.203614526E 04

 SEGMENT NO=82
 X(M)= 0.738612500E 04
 FX= 0.0
 RX= 0.225914727E 05

 Z(M)= 0.143090668E 02
 FZ= 0.452500000E 03
 RZ= 0.158364526E 04

 SEGMENT NO=83
 X(M)= 0.747600781E 04
 FX= 0.0
 RX= 0.225914727E 05

 Z(M)= 0.188095245E 02
 FZ= 0.452500000E 03
 PZ= 0.113114526E 04

 SEGMENT NO=84
 X(M)= 0.756595313E 04
 FX= 0.0
 RX= 0.225914727E 05

 Z(M)= 0.215115204E 02
 FZ= 0.452500000E 03
 PZ= 0.678645264E 03

 SEGMENT NO=85

X(M) = 0.765592578E 04
FX = 0.0
RX = 0.225914727E 05
SEGMENT NO=86
X(M) = 0.774589063E 04
FX = 0.0
RX = 0.225914727E 05
SEGMENT NO=87
X(M) = 0.783580859E 04
FX = 0.0
RX = 0.225914727E 05
SEGMENT NO=88
X(M) = 0.792564844E 04
FX = 0.0
RX = 0.225914727E 05
SEGMENT NO=89
X(M) = 0.801537500E 04
FX = 0.0
RX = 0.225914727E 05
SEGMENT NO=90
X(M) = 0.810494922E 04
FX = 0.0
RX = 0.225914727E 05
SEGMENT NO=91
X(M) = 0.819427734E 04
FX = 0.0
RX = 0.225914727E 05
SEGMENT NO=92
X(M) = 0.828373438E 04
FX = 0.0
RX = 0.225914727E 05
SEGMENT NO=93
X(M) = 0.837328516E 04
FX = 0.0
RX = 0.225914727E 05
SEGMENT NO=94
X(M) = 0.846289453E 04
FX = 0.0
RX = 0.225914727E 05
SEGMENT NO=95
X(M) = 0.855253125E 04
FX = 0.0
RX = 0.225914727E 05
SEGMENT NO=96
X(M) = 0.864215625E 04
FX = 0.0
RX = 0.225914727E 05
SEGMENT NO=97
X(M) = 0.873173438E 04
Y(M) = -0.174244476E 03
FY = -0.199099884E 02
PY = 0.243682715F 04
Y(M) = -0.164461014E 03
FY = -0.199099884E 02
PY = 0.245673706E 04
Y(M) = -0.154603104E 03
FY = -0.199099884E 02
PY = 0.247664722E 04
Y(M) = -0.144674759E 03
FY = -0.199099884E 02
PY = 0.249655713E 04
Y(M) = -0.134680038E 03
FY = -0.199099884E 02
PY = 0.251646704E 04
Y(M) = -0.124623077E 03
FY = -0.519909912E 03
RY = 0.253637695E 04
Y(M) = -0.112538300E 03
FY = -0.199099884E 02
PY = 0.305628613E 04
Y(M) = -0.100357162E 03
FY = -0.199099884E 02
RY = 0.307619604F 04
Y(M) = -0.880841980E 02
FY = -0.199099884E 02
PY = 0.309610596E 04
Y(M) = -0.757240448E 02
FY = -0.199099884E 02
PY = 0.311601611E 04
Y(M) = -0.632815094E 02
FY = -0.199099884E 02
RY = 0.313592603F 04
Y(M) = -0.507614899E 02
FY = -0.199099884E 02
RY = 0.315583594E 04
Y(M) = -0.381689606E 02
Z(M) = 0.224121704E 02
FZ = 0.452500000E 03
RZ = 0.226145264E 03
Z(M) = 0.215107574E 02
FZ = 0.452500000E 03
RZ = -0.226354736E 03
Z(M) = 0.188086700E 02
FZ = 0.452500000E 03
RZ = -0.678854736E 03
Z(M) = 0.143094873E 02
FZ = 0.452500000E 03
RZ = -0.113135474E 04
Z(M) = 0.801885700E 01
FZ = 0.452500000E 03
RZ = -0.158395474E 04
Z(M) = -0.55466519E -01
FZ = -0.407250000E 04
RZ = -0.203635474E 04
Z(M) = 0.799559689F 01
FZ = 0.452500000E 03
RZ = 0.203614526E 04
Z(M) = 0.142665224E 02
FZ = 0.452500000E 03
RZ = 0.158364526E 04
Z(M) = 0.187503815E 02
FZ = 0.452500000E 03
RZ = 0.113114526E 04
Z(M) = 0.214423214E 02
FZ = 0.452500000E 03
RZ = 0.678645264E 03
Z(M) = 0.223395996E 02
FZ = 0.452500000E 03
RZ = 0.226145264E 03
Z(M) = 0.214415894E 02
FZ = 0.452500000E 03
RZ = -0.226354736E 03
Z(M) = 0.187497711E 02

OS/360 FORTRAN H

C MOTIONS AND STRESSES IN PIPE TOWERS WITH SEA SPIDER CONFIGURATIONS
 C THAT ARE ACTED UPON BY EXTERNAL FORCES EXERTED BY THE PIPE AND CURRENTS

C COMPUTER PROGRAM BY G H SAVAGE. AN ALTERATION OF A PROGRAM TO
 C SHOW THE MOTIONS OF AN INDEPENDENT TRI-MOORED BUOY BY
 C G H SAVAGE, S C PAHUJA AND R W CORELL, UNIVERSITY OF NEW HAMPSHIRE
 C WHO ADAPTED WORK ON IMAGINARY REACTIONS BY SKOP AND KAPLAN, NAVAL
 C RESEARCH LABORATORIES, TO THE IBM 360/40 AND 360/65
 C DEFLECTION ANALYSIS USING THE METHOD OF IMAGINARY REACTIONS

```

  ISN 0002 REAL BL,BLBAR,BLT,MU,MUE,MUU,MUUE
  ISN 0003 COMMON/C2/FX(21,3),FY(21,3),FZ(21,3)
  ISN 0004 COMMON/C1/XF,X(21,3),YF,Y(21,3),ZF,Z(21,3)
  ISN 0005 COMMON/C3/W(21,3),WC(21,3),WE(10,21,3)
  ISN 0006 COMMON/C4/MMAX(3),KMAX(21,3),KTILDA(21,3)
  ISN 0007 COMMON/C5/BLBAR(21,3),BL(21,3),SBAR(10,21,3),T(21,3),BLT(21,3)
  ISN 0008 COMMON/C6/AA1(3),BB1(3),CC1(3),E,DELTA,JUMP,LDJPE,LOOPA
  ISN 0009 COMMON/C7/HORIZL(21,3),HEIGHT(21,3)
  ISN 0010 COMMON/C8/CX(21,3),CY(21,3),CZ(21,3)
  ISN 0011 COMMON/C9/AV(5),BV(5),VF,V(5),HF,H(5)
  ISN 0012 COMMON/C10/COMPE,COMPD,PSI,STAPSI,DELPST,ENDPSI
  ISN 0013 COMMON/C11/XTEN(21,3),MU(21,3),MUE(10,21,3),RD(21,3)
  ISN 0014 COMMON/C12/ALPHA(21,3),BETA(21,3),GAMMA(21,3)
  ISN 0015 COMMON/C13/RX(21,3),RY(21,3),RZ(21,3)
  ISN 0016 COMMON/C14/XO(21,3),YO(21,3),ZO(21,3)
  ISN 0017 COMMON/C15/XB(21,3),YB(21,3),ZB(21,3)
  ISN 0018 COMMON/C16/FXP(3),FYP(3),FZP(3),XP(3),YP(3),ZP(3)
  ISN 0019 COMMON/C17/DELTA1
  ISN 0020 COMMON/C18/FFX(21,3),FFY(21,3),FFZ(21,3)
  ISN 0021 COMMON/C19/FXPIP,FYPIP,FZPIP
  ISN 0022 WRITE(6,606)
  ISN 0023 606 FORMAT(1H1)
  C COUNT THE ANCHOR POSITIONS ENTERED
  ISN 0024 SAV=1
  C COUNT THE NUMBER OF PIPE FORCE CARDS / ANCHOR POSITION / BUOY SIZE
  ISN 0025 611 RAG=1
  C READ AND PRINT INPUT INFORMATION
  ISN 0026 CALL INPUT
  C COMPUTE MIDSEGMENT DISCRETE ELEMENT KTILDA(M,N)
  ISN 0027 610 DO 2 N= 1,3
  ISN 0028 MX = MMAX(N)
  ISN 0029 DO 2 M = 2,MX
  ISN 0030 KX = KMAX(M,N)
  ISN 0031 DO 1 K = 1,KX
  ISN 0032 IF(SBAR(K,M,N).GT.BLRAR(M,N)/2.)GO TO 2
  ISN 0034 1 CONTINUE
  ISN 0035 K = KX+1
  ISN 0036 2 KTILDA(M,N) = K-1
  C SUBSCRIPTS FOR PRIMARY ANCHOR
  ISN 0037 X(1,1) = AA1(1)
  ISN 0038 Y(1,1) = BB1(1)
  ISN 0039 Z(1,1) = CC1(1)
  C INITIAL VALUES
  ISN 0040 LEAP = 1
  ISN 0041 JUMP = 1
  
```



```

ISN 0042      PSI = STAPSI
ISN 0043      PI = 3.14159265
ISN 0044      LOOPE = 0
ISN 0045      LOOPA = 0
ISN 0046      BOUNT=0
C
ISN 0047      159 CALL GFORC
ISN 0048      WRITE(6,154)
ISN 0049      WRITE(6,683)
ISN 0050      683 FORMAT(1H1)
ISN 0051      154 FORMAT(10X,'GRAVITY FORCES CALCULATED WITH THE PIPE ATTACHED TO
              1THE APEX OF THE TOWER'/)
C
ISN 0052      3 DO 7 NN = 1,3
ISN 0053      N = 4-NN
ISN 0054      MX = MMAX(N)
ISN 0055      GO TO(5,4,4),N
ISN 0056      4 RX(MX,N) = FX(MX,N)
ISN 0057      RY(MX,N) = FY(MX,N)
ISN 0058      RZ(MX,N) = FZ(MX,N)
ISN 0059      GO TO 6
ISN 0060      5 RX(MX,1) = FX(MX,1)+RX(2,2)+RX(2,3)
ISN 0061      RY(MX,1) = FY(MX,1)+RY(2,2)+RY(2,3)
ISN 0062      RZ(MX,1) = FZ(MX,1)+RZ(2,2)+RZ(2,3)
ISN 0063      6 T(MX,N) = SQRT(RX(MX,N)**2+RY(MX,N)**2+RZ(MX,N)**2)
ISN 0064      BL(MX,N) = BLBAR(MX,N)*(1.+T(MX,N)/XTEN(MX,N))
ISN 0065      BLT(MX,N) = BL(MX,N)/T(MX,N)
ISN 0066      MX = MX-1
ISN 0067      DO 7 MM = 2, MX
ISN 0068      M = MX-MM+2
ISN 0069      8 RX(M,N) = FX(M,N)+RX(M+1,N)
ISN 0070      RY(M,N) = FY(M,N) + RY(M+1,N)
ISN 0071      RZ(M,N) = FZ(M,N) + RZ(M+1,N)
ISN 0072      16 T(M,N) = SQRT(RX(M,N)**2+RY(M,N)**2+RZ(M,N)**2)
ISN 0073      BL(M,N) = BLBAR(M,N)*(1.+T(M,N)/XTEN(M,N))
ISN 0074      7 BLT(M,N) = BL(M,N)/T(M,N)
C
ISN 0075      COMPUTE X,Y,Z COORDINATES OF EACH STATION
ISN 0076      DO 10 N = 1,3
ISN 0077      MX = MMAX(N)
ISN 0078      DO 9 M = 2, MX
ISN 0079      X(M,N) = BLT(M,N)*RX(M,N)+X(M-1,N)
ISN 0080      Y(M,N) = BLT(M,N)*RY(M,N)+Y(M-1,N)
ISN 0081      9 Z(M,N) = BLT(M,N)*RZ(M,N)+Z(M-1,N)
ISN 0082      GO TO(27,10),N
ISN 0083      27 DO 110 NN = 2,3
ISN 0084      X(1,NN) = X(MX,1)
ISN 0085      Y(1,NN) = Y(MX,1)
ISN 0086      110 Z(1,NN) = Z(MX,1)
ISN 0087      10 CONTINUE
C
ISN 0088      COMPUTE ERROR FUNCTION
ISN 0089      LOOPE = LOOPE+1
ISN 0090      E = 0
ISN 0091      DO 11 N = 2,3
              M = MMAX(N)
              11 E = E+((AA1(N)-X(M,N))**2+(BB1(N)-Y(M,N))**2+(CC1(N)-Z(M,N))**2)

```

```

ISN 0092          IF(E.GT.COMPE)GO TO(19,50,15),LEAP
C                UPDATED DIRECTION COSINES
ISN 0094          DO 300 N = 1,3
ISN 0095          MX = MMAX(N)
ISN 0096          DO 300 M = 2,MX
ISN 0097          ALPHA(M,N) = (X(M,N)-X(M-1,N))/BL(M,N)
ISN 0098          BETA(M,N) = (Y(M,N)-Y(M-1,N))/BL(M,N)
ISN 0099          300 GAMMA(M,N) = (Z(M,N)-Z(M-1,N))/BL(M,N)
C                ERROR FUNCTION COMPARISION SATISFIED
ISN 0100          GO TO(51,52),JUMP
C                PRINT AND STORE EQUILIBRIUM POSITION
ISN 0101          51 CALL STAPOS
ISN 0102          JUMP = 2
ISN 0103          LOOPE = 0
ISN 0104          DO 53 N = 1,3
ISN 0105          MX = MMAX(N)
ISN 0106          DO 53 M = 2,MX
ISN 0107          XO(M,N) = X(M,N)
ISN 0108          YO(M,N) = Y(M,N)
ISN 0109          ZO(M,N) = Z(M,N)
ISN 0110          XB(M,N) = X(M,N)
ISN 0111          YB(M,N) = Y(M,N)
ISN 0112          ZB(M,N) = Z(M,N)
ISN 0113          53 CONTINUE
ISN 0114          GO TO 61
C                COMPARE ACCURACY OF COORDINATES
ISN 0115          52 DO 55 N = 1,3
ISN 0116          MX = MVALUE(N)
ISN 0117          DO 55 M = 2,MX
ISN 0118          IF(ABS(X(M,N)-XO(M,N)).GT.COMPD.OR.
                1ABS(Y(M,N)-YO(M,N)).GT.COMPD.OR.
                2ABS(Z(M,N)-ZO(M,N)).GT.COMPD)GO TO 57
ISN 0120          55 CONTINUE
C                ACCURACY SATISFIED-PRINT EQUILIBRIUM POSITION
ISN 0121          DO 56 N = 1,3
ISN 0122          MX = MMAX(N)
ISN 0123          DO 56 M = 2,MX
ISN 0124          HORIZL(M,N) = SQRT((X(M,N)-XB(M,N))**2 + (Y(M,N)-YB(M,N))**2)
ISN 0125          HEIGHT(M,N) = Z(M,N)-ZB(M,N)
ISN 0126          56 CONTINUE
ISN 0127          999 CALL DYNPOS
ISN 0128          LOOPE = 0
ISN 0129          LOOPA = 0
ISN 0130          GO TO 60
C                ACCURACY NOT ADEQUATE-REITERATE
ISN 0131          57 DO 59 N = 1,3
ISN 0132          MX = MVALUE(N)
ISN 0133          DO 59 M = 2,MX
ISN 0134          XO(M,N) = X(M,N)
ISN 0135          YO(M,N) = Y(M,N)
ISN 0136          ZO(M,N) = Z(M,N)
ISN 0137          59 CONTINUE
ISN 0138          GO TO 62
C                ERROR FUNCTION COMPARISION NOT SATISFIED
ISN 0139          50 IF(E.LT.EP)GO TO 20

```

```

C      INCREASE IN ERROR FUNCTION
ISN 0141      DELTA=DELTA/2
C      COMPUTE ERROR FUNCTION
ISN 0142      12 DE = DELTA/SQRT(EP)
ISN 0143      DO 13 N = 2,3
ISN 0144      MX = MMAX(N)
ISN 0145      FX(MX,N) = FXP(N)+(AA1(N)-XP(N))*DE
ISN 0146      FY(MX,N) = FYP(N)+(BB1(N)-YP(N))*DE
ISN 0147      FZ(MX,N) = FZP(N)+(CC1(N)-ZP(N))*DE
ISN 0148      13 CONTINUE
C      CHECK CHANGES IN IMAGINARY REACTIONS
ISN 0149      DO 14 N = 2,3
ISN 0150      IF(FX(MX,N).NE.FXP(N).OR.
              1FY(MX,N).NE.FYP(N).OR.
              2FZ(MX,N).NE.FZP(N))GO TO 3
ISN 0152      14 CONTINUE
ISN 0153      LEAP = 3
ISN 0154      GO TO 3
C      NO CHANGE TIME TO QUIT
ISN 0155      15 CALL EXITT
ISN 0156      GO TO 100
C      DECREASE IN ERROR FUNCTUUN
ISN 0157      19 LEAP = 2
ISN 0158      20 EP = E
ISN 0159      DO 21 N = 2,3
ISN 0160      MX = MMAX(N)
ISN 0161      XP(N) = X(MX,N)
ISN 0162      YP(N) = Y(MX,N)
ISN 0163      ZP(N) = Z(MX,N)
ISN 0164      FXP(N) = FX(MX,N)
ISN 0165      FYP(N) = FY(MX,N)
ISN 0166      FZP(N) = FZ(MX,N)
ISN 0167      21 CONTINUE
ISN 0168      GO TO 12
C      INCREASE CURRENT ANGLE
ISN 0169      60 PSI = PSI+DELPSI
ISN 0170      IF(PSI.GE.ENDPSI)GO TO 100
ISN 0172      61 COSPSI = COS(PSI*PI/180.)
ISN 0173      SINPSI = SIN(PSI*PI/180.)
ISN 0174      62 DELTA = DELTA1
ISN 0175      LEAP = 1
ISN 0176      LOOPA = LOOPA+1
C DRAG COEFFICIENTS
C
ISN 0177      DO 30 N = 1, 3
ISN 0178      MX = MMAX(N)
ISN 0179      DO 30 M = 2, MX
ISN 0180      CADELT=SQRT((BETA(M,N)*COSPSI-ALPHA(M,N)*SINPSI)**2
              + GAMMA(M,N)**2 )
ISN 0181      1 BUFFER = ALPHA(M,N)*COSPSI + BETA(M,N)*SINPSI
ISN 0182      CX(M,N)=MU(M,N)*(CADELT*
              1 ( GAMMA(M,N)**2 + BETA(M,N)**2)*COSPSI
              2 - ALPHA(M,N) * BETA(M,N) * SINPSI )
              3 + RD(M,N) * ALPHA(M,N) * BUFFER )
ISN 0183      CY(M,N)=MU(M,N)*(CADELT*

```

```

1          ( (GAMMA(M,N)**2 + ALPHA(M,N)**2)*SINPSI
2          - ALPHA(M,N) * BETA(M,N) * COSPSI )
3          + RD(M,N) * BETA(M,N) * BUFFER )
ISN 0184 30 CZ(M,N)=MU(M,N)*GAMMA(M,N)*BUFFER*(RD(M,N)-CADFLT)
C COMPUTE CABLE DRAG FORCES HX,HY,HZ-AND ELEMENT DRAG FORCES HXE,HYE
ISN 0185 DO 40 N = 1, 3
ISN 0186 MX = MVALUE(N)
ISN 0187 DO 40 M = 2, MX
ISN 0188 MXMN=MX-M+N
ISN 0189 IF(MXMN-2)23,24,24
ISN 0190 24 A1 = AREA(M,N,1)
ISN 0191 A2 = AREA(M+1,N,2)
ISN 0192 HX = CX(M,N) * A1 + CX(M+1,N) * A2
ISN 0193 HY = CY(M,N) * A1 + CY(M+1,N) * A2
ISN 0194 HZ = CZ(M,N) * A1 + CZ(M+1,N) * A2
ISN 0195 DT = AREA(M,N,3)+AREA(M+1,N,4)
ISN 0196 HXE = DT * COSPSI
ISN 0197 HYE = DT * SINPSI
ISN 0198 GO TO 26
ISN 0199 23 A1 = AREA(MX,1,1)
ISN 0200 A2 = AREA(2,2,2)
ISN 0201 A3 = AREA(2,3,2)
ISN 0202 HX = CX(M,N) * A1 + CX(2,2) * A2 + CX(2,3) * A3
ISN 0203 HY = CY(M,N) * A1 + CY(2,2) * A2 + CY(2,3) * A3
ISN 0204 HZ = CZ(M,N) * A1 + CZ(2,2) * A2 + CZ(2,3) * A3
ISN 0205 DT = AREA(MX,1,3)+AREA(2,2,4)+AREA(2,3,4)
ISN 0206 HXE = DT * COSPSI
ISN 0207 HYE = DT * SINPSI
C NEW TOTAL FORCES
ISN 0208 26 FX(M,N) = HX + HXE
ISN 0209 FY(M,N) = HY + HYE
ISN 0210 FZ(M,N) = HZ + W(M,N)
ISN 0211 40 CONTINUE
ISN 0212 FX(MMAX(1),1) = FX(MMAX(1),1) + FXPIP
ISN 0213 FY(MMAX(1),1) = FY(MMAX(1),1) + FYPIP
ISN 0214 FZ(MMAX(1),1) = FZ(MMAX(1),1) + FZPIP
ISN 0215 GO TO 3
ISN 0216 100 RAG = RAG + 1
ISN 0217 PSI=PSI-DELPSI
ISN 0218 IF(RAG.GT.1)GO TO 602
ISN 0220 READ(5,600)FXPIP,FYPIP,FZPIP
ISN 0221 600 FORMAT(3F10.0)
ISN 0222 GO TO 610
ISN 0223 602 IF (SAV.GT.3)GO TO 603
ISN 0225 GO TO 611
ISN 0226 603 STOP
ISN 0227 END

```

```

ISN 0002      FUNCTION AREA(M,N,IGO)
ISN 0003      REAL BL,BLBAR,BLT,MU,MUF,MUU,MUUE
ISN 0004      COMMON/C1/XF,X(21,3),YF,Y(21,3),ZF,Z(21,3)
ISN 0005      COMMON/C4/MMAX(3),KMAX(21,3),KTILDA(21,3)
ISN 0006      COMMON/C5/BLBAR(21,3),BL(21,3),SBAR(10,21,3),T(21,3),BLT(21,3)
ISN 0007      COMMON/C9/AV(5),BV(5),VF,V(5),HF,H(5)
ISN 0008      COMMON/C11/XTEN(21,3),MU(21,3),MUE(10,21,3),RD(21,3)
ISN 0009      COMMON/C12/ALPHA(21,3),BETA(21,3),GAMMA(21,3)
ISN 0010      GO TO(100,200,300,400),IGO
C
ISN 0011      100 CONTINUE
ISN 0012      KL = LIMIT(Z(M-1,N)+GAMMA(M,N)*BL(M,N)/2.)
ISN 0013      KU = LIMIT ( Z(M,N) )
ISN 0014      TOP = BL(M,N)
ISN 0015      BOT = BL(M,N)/2.
ISN 0016      2 KMIN = MINO ( KU, KL )
ISN 0017      KTOP = KMIN - 1 + IABS ( KU-KL )
ISN 0018      SUM = 0.
ISN 0019      IF(KMIN.GT.KTOP) GO TO 10
ISN 0021      DO 1 K = KMIN, KTOP
ISN 0022      XI = (H(K)-Z(M-1,N)) / GAMMA(M,N)
ISN 0023      1 SUM = SUM + AREAS(M,N,K,XI) - AREAS(M,N,K+1,XI)
ISN 0024      10 AREA = SYGN(KU-KL)*SUM+AREAS(M,N,KU, TOP)-AREAS(M,N,KL,3JT)
ISN 0025      RETURN
C
ISN 0026      200 CONTINUE
ISN 0027      KL = LIMIT(Z(M-1,N))
ISN 0028      KU = LIMIT(Z(M-1,N)+GAMMA(M,N)*BL(M,N)/2.)
ISN 0029      TOP = BL(M,N)/2.
ISN 0030      BOT = 0.
ISN 0031      GO TO 2
C
ISN 0032      300 CONTINUE
ISN 0033      KB = KTILDA(M,N) + 1
ISN 0034      KX = KMAX(M,N)
ISN 0035      5 SUM = 0.
ISN 0036      IF(KB.GT.KX)GO TO 40
ISN 0038      DO 4 K = KB, KX
ISN 0039      ZT = Z(M-1,N) + GAMMA(M,N) * SBAR(K,M,N)*(1.+T(M,N)/XTEN(M,N))
ISN 0040      J = LIMIT( ZT )
ISN 0041      4 SUM = SUM + MUE(K,M,N) * (AV(J) + BV(J) * ZT)**2
ISN 0042      40 AREA = SUM
ISN 0043      RETURN
C
ISN 0044      400 CONTINUE
ISN 0045      KB = 1
ISN 0046      KX = KTILDA(M,N)
ISN 0047      GO TO 5
ISN 0048      END

```

OS/360 FORTRAN H

```
ISN 0002      FUNCTION SYGN(J)
ISN 0003      IF ( J ) 1, 2, 3
ISN 0004      1 SYGN = -1.
ISN 0005      RETURN
ISN 0006      2 SYGN = 0
ISN 0007      RETURN
ISN 0008      3 SYGN = 1.
ISN 0009      RETURN
ISN 0010      END
```

```
ISN 0002      FUNCTION AREAS(M,N,K,XI)
ISN 0003      COMMON/C1/XF,X(21,3),YF,Y(21,3),ZF,Z(21,3)
ISN 0004      COMMON/C9/AV(5),BV(5),VF,V(5),HF,H(5)
ISN 0005      COMMON/C12/ALPHA(21,3),BETA(21,3),GAMMA(21,3)
ISN 0006      AREAS = (AV(K)+BV(K)*Z(M-1,N))**2 * XI
1             +(AV(K)+BV(K)*Z(M-1,N))*BV(K)*GAMMA(M,N) * (XI**2)
2             +(BV(K)*GAMMA(M,N))**2 * (XI**3/3.)
ISN 0007      RETURN
ISN 0008      END
```

```
ISN 0002      FUNCTION MVALUE(N)
ISN 0003      COMMON/C4/MMAX(3),KMAX(21,3),KTILDA(21,3)
ISN 0004      GO TO(1,2,2),N
ISN 0005      1 MVALUE = MMAX(N)
ISN 0006      RETURN
ISN 0007      2 MVALUE = MMAX(N) - 1
ISN 0008      RETURN
ISN 0009      END
```



```

ISN 0002      SUBROUTINE GFORC
ISN 0003      REAL BL,BLBAR,BLT,MU,MUE,MUU,MUUE
ISN 0004      COMMON/C2/FX(21,3),FY(21,3),FZ(21,3)
ISN 0005      COMMON/C3/W(21,3),WC(21,3),WE(10,21,3)
ISN 0006      COMMON/C4/MMAX(3),KMAX(21,3),KTILDA(21,3)
ISN 0007      COMMON/C5/BLBAR(21,3),BL(21,3),S9AR(10,21,3),T(21,3),BLT(21,3)
ISN 0008      COMMON/C6/AA1(3),BB1(3),CC1(3),E,DELTA,JUMP,LOOPE,LOOPA
ISN 0009      COMMON/C17/DELTA
ISN 0010      COMMON/C19/FXPIP,FYPIP,FZPIP
C             COMPUTE STATION GRAVITY FORCES W(M,N)- AND INITIAL FORCES FX,FY,FZ
ISN 0011      WT = 0.
ISN 0012      DO 3 N = 1, 3
ISN 0013      MX = MMAX(N) - 1
ISN 0014      DO 3 M = 2, MX
ISN 0015      WX = 0.
ISN 0016      FX(M,N) = 0.
ISN 0017      FY(M,N) = 0.
ISN 0018      KB = KTILDA(M,N) + 1
ISN 0019      KX = KMAX(M,N)
ISN 0020      IF(KB.GT.KX) GO TO 10
ISN 0022      DO 1 K = KB, KX
ISN 0023      1 WX = WX + WE(K,M,N)
ISN 0024      10 KX = KTILDA(M+1,N)
ISN 0025      IF(KX.EQ.0) GO TO 30
ISN 0027      DO 2 K = 1, KX
ISN 0028      2 WX = WX + WE(K,M+1,N)
ISN 0029      30 W(M,N) = WX+WC(M,N)*BLBAR(M,N)/2.+WC(M+1,N)*BLBAR(M+1,N)/2.
ISN 0030      FZ(M,N) = W(M,N)
ISN 0031      3 WT = WT + W(M,N)
ISN 0032      WX = 0.
ISN 0033      FX(MMAX(1),1) = 0.
ISN 0034      FY(MMAX(1),1) = 0.
ISN 0035      KB = KTILDA(MMAX(1),1) + 1
ISN 0036      KX = KMAX(MMAX(1),1)
ISN 0037      IF(KB.GT.KX) GO TO 20
ISN 0039      DO 4 K = KB, KX
ISN 0040      4 WX = WX + WE(K,MMAX(1),1)
ISN 0041      20 CONTINUE
ISN 0042      DO 6 N = 2, 3
ISN 0043      KX = KTILDA(2,N)
ISN 0044      FX(MMAX(N),N) = 0.
ISN 0045      FY(MMAX(N),N) = 0.
ISN 0046      IF(KX.EQ.0) GO TO 6
ISN 0048      DO 5 K = 1, KX
ISN 0049      5 WX = WX + WE(K,2,N)
ISN 0050      6 WX = WX+WC(2,N)*BLBAR(2,N)/2.
ISN 0051      W(MMAX(1),1) = WX+WC(MMAX(1),1)*BLBAR(MMAX(1),1)/2.
ISN 0052      FZ(MMAX(1),1) = W(MMAX(1),1) + FZPIP
ISN 0053      DO 35 N = 2,3
ISN 0054      FX(1,N) = FX(MMAX(1),1)
ISN 0055      FY(1,N) = FY(MMAX(1),1)
ISN 0056      35 FZ(1,N) = FZ(MMAX(1),1)
ISN 0057      WT = WT + W(MMAX(1),1)

```

```
ISN 0058      DO 7 N = 2, 3
ISN 0059      7 FZ(MMAX(N),N) = -WT / 3.

C
C      COMPUTE INITIAL DELTA
ISN 0060      SQ2 = SQRT ( 2. )
ISN 0061      DELTA1 = ABS(SQ2*WT/3.)
ISN 0062      DELTA = DELTA1
ISN 0063      997 CONTINUE
ISN 0064      RETURN
ISN 0065      END
```

COMPILER OPTIONS -

```

ISN 0002      SUBROUTINE OUTPUT
ISN 0003      REAL BL,BLBAR,BLT,MU,MUE,MUU,MUUE
ISN 0004      COMMON/C1/XF,X(21,3),YF,Y(21,3),ZF,Z(21,3)
ISN 0005      COMMON/C2/FX(21,3),FY(21,3),FZ(21,3)
ISN 0006      COMMON/C3/W(21,3),WC(21,3),WE(10,21,3)
ISN 0007      COMMON/C4/MMAX(3),KMAX(21,3),KTILDA(21,3)
ISN 0008      COMMON/C5/BLBAR(21,3),BL(21,3),SBAR(10,21,3),T(21,3),BLT(21,3)
ISN 0009      COMMON/C6/AA1(3),BB1(3),CC1(3),E,DELTA,JUMP,LOOPE,LOOPA
ISN 0010      COMMON/C7/HORIZL(21,3),HEIGHT(21,3)
ISN 0011      COMMON/C10/COMPE,COMPD,PSI,STAPSI,DELPSI,ENDPSI
ISN 0012      COMMON/C11/XTEN(21,3),MU(21,3),MUE(10,21,3),RD(21,3)
ISN 0013      COMMON/C19/FXPIP,FYPIP,FZPIP
ISN 0014      ENTRY STAPOS
ISN 0015      WRITE(6,13)
ISN 0016      16 WRITE(6,5)E,DELTA,LOOPE
ISN 0017      5 FORMAT(1X,41HEQUILIBRIUM POSITION UNDER GRAVITY FORCES,/,10X,
1              2HE=,F16.9,10X, 6HDELTA=,E16.9,10X,19HNO. OF ERROR LOOPS=
2              ,I5)
ISN 0018      WRITE(6,200)
ISN 0019      200 FORMAT(/,1X,'PIPE AND MAIN BUOY LIFT FORCE COMPONENTS'/)
ISN 0020      WRITE(6,680)WE(KMAX(MMAX(1),1),MMAX(1),1),FZPIP
ISN 0021      680 FORMAT(10X,'BUOY BUOYANCY(LBS.)=',F10.2,2X,'FZPIP=',F10.0//)
ISN 0022      WRITE(6,690)
ISN 0023      690 FORMAT(/,2X,'FORCE AND MOTION VALUES FOR KEY SEGMENTS'/)
ISN 0024      6 DO 10 N=1,3
ISN 0025      WRITE(6,7)N
ISN 0026      7 FORMAT(/,3X,13HCABLE NUMBER=,I2)
ISN 0027      MX=MMAX(N)
ISN 0028      MMX=MX-2
ISN 0029      DO 10 M=2,MX,MMX
ISN 0030      I=M-1
ISN 0031      WRITE(6,8)I,FX(M,N),FY(M,N),FZ(M,N),X(M,N),Y(M,N),Z(M,N),T(M,N),
1BL(M,N)
ISN 0032      8 FORMAT(/,5X,15HSEGMENT NUMBER=,I2,/
1 10X,8HFX(M,N)=,E16.9,10X,8HFY(M,N)=,E16.9,10X,8HFZ(M,N)=,E16.9/
2 10X,7HX(M,N)=,E16.9,10X,7HY(M,N)=,E16.9,10X,7HZ(M,N)=,E16.9/
3 10X,8HT(M,N)=,E16.9,10X,8HBL(M,N)=,E16.9)
ISN 0033      GO TO(10,9),JUMP
ISN 0034      9 WRITE(6,11)HORIZL(M,N),HEIGHT(M,N)
ISN 0035      11 FORMAT(15X,12HHORIZL(M,N)=,E16.9,10X,12HHEIGHT(M,N)=,E16.9)
ISN 0036      10 CONTINUE
ISN 0037      RETURN
ISN 0038      ENTRY DYNPOS
ISN 0039      WRITE(6,13)
ISN 0040      WRITE(6,116)
ISN 0041      116 FORMAT(13X,'EQUILIBRIUM POSITION UNDER ACTING FORCES'//)
ISN 0042      17 WRITE(6,12)E,DELTA,LOOPE,LOOPA,PSI
ISN 0043      12 FORMAT(10X,2HE=,E16.9,10X,6HDELTA=,E16.9/13X,19HNO. OF ERROR LOOPS
1=,I5,10X,22HNO. OF ACCURACY LOOPS=,I5/15X,14HCURRENT ANGLE=,
2F8.3/)
ISN 0044      WRITE(6,681)FXPIP,FYPIP,FZPIP
ISN 0045      681 FORMAT(10X,'FXPIP=',F10.0,2X,'FYPIP=',F10.0,2X,'FZPIP=',F10.0//)
ISN 0046      GO TO 6

```

```

ISN 0047      ENTRY EXITT
ISN 0048      WRITE(6,13)
ISN 0049      WRITE(6,14)
ISN 0050      14 FORMAT(1X//1X,90HPROBLEM NOT COMPLETED, DELTA HAS GOTTEN TOO SMALL
              1TO CHANGE THE IMAGINARY REACTIONS
              2/1X,100HEITHER ACCURACY REQUIREMENTS ARE TOO SMALL(COMPE) OR A CAB
              3LE HAS GONE SLACK (CHECK TENSIONS).
              4/1X,55HPRINTOUT IS GIVEN FOR TROUBLE SHOOTING PURPOSES ONLY.   )
ISN 0051      GO TO(16,17),JUMP
ISN 0052      13 FORMAT ( 1H1 )
ISN 0053      END

```

```
ISN 0002      FUNCTION LIMIT(ZT)
ISN 0003      COMMON/C9/AV(5),BV(5),VF,V(5),HF,H(5)
ISN 0004      DO 1 J = 2,5
ISN 0005      IF(ZT-H(J))2,2,1
ISN 0006      1 CONTINUE
ISN 0007      2 LIMIT = J
ISN 0008      RETURN
ISN 0009      END
```

```
ISN 0002      SUBROUTINE VPROFL
ISN 0003      COMMON/C9/AV(5),BV(5),VF,V(5),HF,H(5)
ISN 0004      K=1
ISN 0005      1 READ(5,2)H(K),V(K)
ISN 0006      2 FORMAT(2F10.0)
ISN 0007      IF ( H(K) .GE. 40000. ) GO TO 3
ISN 0009      K = K + 1
ISN 0010      GO TO 1
ISN 0011      3 KX = K
ISN 0012      DO 4 K=2,KX
ISN 0013      BV(K) = (V(K)-V(K-1)) / (H(K)-H(K-1))
ISN 0014      AV(K) = V(K-1)-BV(K)*H(K-1)
ISN 0015      4 WRITE(6,9)AV(K),BV(K)
ISN 0016      9 FORMAT(10X,6HAV(K)=,E16.5/10X,6HBV(K)=,E16.5)
ISN 0017      RETURN
ISN 0018      END
```

```

ISN 0002      SUBROUTINE INPUT
ISN 0003      REAL BL,BLBAR,BLT,MU,MUE,MUU,MUUE
ISN 0004      COMMON/C3/W(21,3),WC(21,3),WE(10,21,3)
ISN 0005      COMMON/C4/MMAX(3),KMAX(21,3),KTILDA(21,3)
ISN 0006      COMMON/C5/BLBAR(21,3),BL(21,3),SBAR(10,21,3),T(21,3),BLT(21,3)
ISN 0007      COMMON/C6/AA1(3),BB1(3),CC1(3),E,DELTA,JUMP,LOOPE,LOOPA
ISN 0008      COMMON/C9/AV(5),BV(5),VF,V(5),HF,H(5)
ISN 0009      COMMON/C10/COMPE,COMP,PSI,STAPSI,DELPSI,ENDPSI
ISN 0010      COMMON/C11/XTEN(21,3),MU(21,3),MUE(10,21,3),RD(21,3)
ISN 0011      COMMON/C19/FXPIP,FYPIP,FZPIP
ISN 0012      DIMENSION SBARS(15), WES(15)

C
C COMPARISON VALUES AND CURRENT ANGLE REQUIREMENTS
ISN 0013      WRITE(6,688)
ISN 0014      688 FORMAT(1H1)
ISN 0015      WRITE(6,35)
ISN 0016      35 FORMAT(5X,'COMPARISON VALUES AND CURRENT ANGLE REQUIREMENTS'/)
ISN 0017      READ(5,1)COMPE,COMP,STAPSI,DELPSI,ENDPSI
ISN 0018      1 FORMAT(F10.2,4F10.0)
ISN 0019      WRITE(6,30)COMPE,COMP,STAPSI,DELPSI,ENDPSI
ISN 0020      30 FORMAT(2X,'COMPARISON VALUE FOR E=',E15.6,'COMPARISON VALUE
FOR DISPLACEMENT=',F8.3/2X,'INITIAL CURRENT ANGLE=',F8.3,
2'DEG','INCREMENT OF ANGLE=',F8.3,'DEG','FINAL CURRENT ANGLE=',
3F8.3,'DEG'/)

C
C EXTERNAL FORCES ACTING ON THE TOWER
ISN 0021      READ(5,201)FXPIP,FYPIP,FZPIP
ISN 0022      201 FORMAT(3F10.0)

C
C ANCHOR POSITIONS
ISN 0023      WRITE(6,40)
ISN 0024      40 FORMAT(10X,'ANCHOR POSITIONS'/)
ISN 0025      DO 31 N = 1,3
ISN 0026      31 READ(5,2)AA1(N),BB1(N),CC1(N)
ISN 0027      2 FORMAT(3F10.0)
ISN 0028      WRITE(6,45)(AA1(N),BB1(N),CC1(N),N=1,3)
ISN 0029      45 FORMAT(2X,'AA1=',F10.0,'BB1=',F10.0,'CC1=',F10.0/)

C NO. OF STATIONS PER CABLE
ISN 0030      WRITE(6,50)
ISN 0031      50 FORMAT(10X,'NO. OF STATIONS PER CABLE'/)
ISN 0032      READ(5,3)(MMAX(N),N=1,3)
ISN 0033      3 FORMAT(3I5)
ISN 0034      WRITE(6,55)(N,MMAX(N),N=1,3)
ISN 0035      55 FORMAT(2X,'CABLE NO.',I1,I5)
ISN 0036      WRITE(6,60)
ISN 0037      60 FORMAT(/,5X,'PROPERTIES OF SEGMENTS AND DISCRETE ELEMENTS'/)

C
C SINCE WE HAVE ASSUMED CONDITIONS SUCH THAT THE PHYSICAL
C CHARACTERISTICS OF EACH SEGMENT OF ALL THREE LEGS ARE ALL THE
C SAME, A MODIFICATION HAS BEEN INTRODUCED HERE TO REDUCE

```

```

C     THE NUMBER OF INPUT CARDS FROM ONE FOR EACH SEGMENT TO ONE
C     FOR ALL THE SEGMENTS IN ALL THREE LEGS.  IN THE EVENT THAT
C     THE USER WISHES TO USE MORE THAN ONE CABLE SIZE ON ANY ONE TOWER,
C     THIS PART OF THE PRESENT PROGRAM MUST BE CHANGED
C     WTC= WEIGHT OF THE CABLE IN WATER PER UNIT LENGTH
C     BLBARS= LENGTH OF A CABLE SEGMENT
C     WCS= WEIGHT OF THE CABLE IN WATER PER UNIT LENGTH
C     TDRAGS= THE NORMAL DRAG COEFF. FOR THE CABLE
C     CABDIAS= THE CABLE DIAMETER
C     PDRAGS= THE TANGENTIAL DRAG COEFF. OF THE CABLE
C     XTENS= THE EXTENSIONAL RIGIDITY OF THE CABLE = MODJLOUS X AREA
C     KMAXS= THE NUMBER OF GLAS FLOATS ATTACHED TO EACH SEGMENT
C     XAREA = CROSS SECTION AREA OF CABLE PER FT.
C     DRAGCF = DRAG COEFFICIENT OF THE CABLE
C
ISN 0038     READ(5,15)BLBARS,WCS,TDRAG,CABDIA,PDRAG,XTENS,KMAXS
ISN 0039     15 FORMAT(5F10.3,F10.2,I5)
ISN 0040     DO 77 KKK=1,KMAXS
ISN 0041     READ(5,20) SBARS(KKK),WES(KKK),DRAGCF,XAREA
ISN 0042     20 FORMAT(4F10.2)
ISN 0043     77 CONTINUE
ISN 0044     DO 10 N=1,3
ISN 0045     WRITE(6,70)N
ISN 0046     70 FORMAT(60X,'CABLE NO.',I1/)
ISN 0047     WRITE(6,65)
ISN 0048     65 FORMAT(4X,'M',3X,'STRESSED LEN.',3X,'WEIGHT/FT',3X,'EXT.RIGIDIT
        1Y',2X,'DRAG CHARACTER',1X,'DRAG COF. RATIO',2X,'K',
        2 6X,'SBAR',9X,'WEIGHT',11X,'MUE')
        MMN=MMA(N)
ISN 0049     DO 10 M=2,MMN
ISN 0050     WC(M,N)=WCS
ISN 0051     BLBAR(M,N)=BLBARS
ISN 0052     XTEN(M,N)=XTENS
ISN 0053     KMAX(M,N)=KMAXS
ISN 0054     MU(M,N)=1.94*TDRAG*CABDIA/24.
ISN 0055     RD(M,N)=PDRAG/TDRAG
ISN 0056     I=M-1
ISN 0057     WRITE(6,24)I,BLBAR(M,N),WC(M,N),XTEN(M,N),MU(M,N),RD(M,N),
ISN 0058     IKMAX(M,N)
ISN 0059     24 FORMAT(I5,5E15.6,I5)
ISN 0060     IF(KMAX(M,N).EQ.0) GO TO 10
ISN 0062     KKN=KMAX(M,N)
ISN 0063     DO 5 K=1,KKN
ISN 0064     SBAR(K,M,N) = SBARS(K)
ISN 0065     WE(K,M,N)=WES(K)
ISN 0066     MUE(K,M,N)=1.94*DRAGCF*XAREA/2.
ISN 0067     5 WRITE(6,25)SBAR(K,M,N),WE(K,M,N),MUE(K,M,N)
ISN 0068     25 FORMAT(85X,3E15.6)
C     ENTER THE MAIN BUOY PARAMETERS AT THE APEX
C     XAREAB = CROSS SECTION AREA OF THE APEX BUOY ON TOWER
C     DRAGCB = DRAG COEFFICIENT OF THE BUOY
C     THESE ARE ENTERED HERE SO THAT THE BUOY IS TREATED AS ONE OF
C     ELEMENTS RATHER THAN BEING TREATED AS AN EXTERNAL FORCE LIKE PIPE
ISN 0069     IF(N.GT.1)GO TO 10
ISN 0071     IF(M.LT.MMA(N).AND.N.EQ.1)GO TO 10

```



```

ISN 0073          KKK=KMAXS+1
ISN 0074          MMM=MMAX(1)
ISN 0075          READ(5,710)SBAR(KKK,MMM,N),WE(KKK,MMM,N),DRAGCB,XAREAB
ISN 0076          710 FORMAT(4F10.2)
ISN 0077          KMAX(M,N)=KKK
ISN 0078          MUE(KKK,MMM,N)=1.94*DRAGCB*XAREAB/2
ISN 0079          WRITE(6,712)SBAR(KKK,MMM,N),WE(KKK,MMM,N),MUE(KKK,MMM,N)
ISN 0080          712 FORMAT(75X,4HBUOY,6X,3E15.6)
ISN 0081          10 CONTINUE
C                 PROVIDE VELOCITY PROFILE IN SUBROUTINE VPROFILE
ISN 0082          CALL VPROFL
ISN 0083          WRITE(6,75)
ISN 0084          75 FORMAT(40X,'XXXXXXXXXXXXXXXXXXXXXXXXXXXX',T1,'1'///)
ISN 0085          RETURN
ISN 0086          END

```

COMPARISON VALUES AND CURRENT ANGLE REQUIREMENTS

COMPARISON VALUE FOR E= 0.100000E 00 COMPARISON VALUE FOR DISPLACEMENT= 1.000
 INITIAL CURRENT ANGLE= 270.000DEGINCREMENT OF ANGLE= 60.000DEGINFINAL CURRENT ANGLE= 300.000DEG

ANCHOR POSITIONS

AA1= -7794.881= 4500.CC1= 0.
 AA1= 7794.881= 4500.CC1= 0.
 AA1= 0.881= -9000.CC1= 0.

NO. OF STATIONS PER CABLE

CABLE NO.1 21
 CABLE NO.2 21
 CABLE NO.3 21

PROPERTIES OF SEGMENTS AND DISCRETE ELEMENTS

CABLE NO.1

M	STRESSED LEN.	WEIGHT/FT	EXT.RIGIDIT	Y	DRAG CHARACTER	DRAG COE.	RATIO	K	SBAR	WEIGHT	MUF
1	0.636400E 03	-0.995000E 00	0.120500E 08	0.990207E-01	0.250000E-01	0.250000E-01	6	6	0.100000E 03	0.976000E 02	0.979050E 01
									0.200000E 03	0.976000E 02	0.979050E 01
									0.300000E 03	0.976000E 02	0.979050E 01
									0.400000E 03	0.976000E 02	0.979050E 01
									0.500000E 03	0.976000E 02	0.979050E 01
									0.600000E 03	0.976000E 02	0.979050E 01
2	0.636400E 03	-0.995000E 00	0.120500E 08	0.990207E-01	0.250000E-01	0.250000E-01	5	5	0.100000E 03	0.976000E 02	0.979050E 01
									0.200000E 03	0.976000E 02	0.979050E 01
									0.300000E 03	0.976000E 02	0.979050E 01
									0.400000E 03	0.976000E 02	0.979050E 01
									0.500000E 03	0.976000E 02	0.979050E 01
									0.600000E 03	0.976000E 02	0.979050E 01
3	0.636400E 03	-0.995000E 00	0.120500E 08	0.990207E-01	0.250000E-01	0.250000E-01	5	5	0.100000E 03	0.976000E 02	0.979050E 01
									0.200000E 03	0.976000E 02	0.979050E 01
									0.300000E 03	0.976000E 02	0.979050E 01
									0.400000E 03	0.976000E 02	0.979050E 01
									0.500000E 03	0.976000E 02	0.979050E 01
									0.600000E 03	0.976000E 02	0.979050E 01
4	0.636400E 03	-0.995000E 00	0.120500E 08	0.990207E-01	0.250000E-01	0.250000E-01	5	5	0.100000E 03	0.976000E 02	0.979050E 01
									0.200000E 03	0.976000E 02	0.979050E 01
									0.300000E 03	0.976000E 02	0.979050E 01
									0.400000E 03	0.976000E 02	0.979050E 01
									0.500000E 03	0.976000E 02	0.979050E 01
									0.600000E 03	0.976000E 02	0.979050E 01
5	0.636400E 03	-0.995000E 00	0.120500E 08	0.990207E-01	0.250000E-01	0.250000E-01	6	6	0.100000E 03	0.976000E 02	0.979050E 01
									0.200000E 03	0.976000E 02	0.979050E 01
									0.300000E 03	0.976000E 02	0.979050E 01
									0.400000E 03	0.976000E 02	0.979050E 01
									0.500000E 03	0.976000E 02	0.979050E 01
									0.600000E 03	0.976000E 02	0.979050E 01
6	0.636400E 03	-0.995000E 00	0.120500E 08	0.990207E-01	0.250000E-01	0.250000E-01	5	5	0.100000E 03	0.976000E 02	0.979050E 01
									0.200000E 03	0.976000E 02	0.979050E 01
									0.300000E 03	0.976000E 02	0.979050E 01
									0.400000E 03	0.976000E 02	0.979050E 01
									0.500000E 03	0.976000E 02	0.979050E 01
									0.600000E 03	0.976000E 02	0.979050E 01

15	0.636400E 03	-0.995000E 00	0.120500E 08	0.990207E-01	0.250000E-01	6	0.600000E 03	0.146400E 03	0.979050E 01
							0.100000E 03	0.976000E 02	0.979050E 01
							0.200000E 03	0.976000E 02	0.979050E 01
							0.300000E 03	0.976000E 02	0.979050E 01
							0.400000E 03	0.976000E 02	0.979050E 01
							0.500000E 03	0.976000E 02	0.979050E 01
							0.600000E 03	0.146400E 03	0.979050E 01
16	0.636400E 03	-0.995000E 00	0.120500E 08	0.990207E-01	0.250000E-01	5	0.100000E 03	0.976000E 02	0.979050E 01
							0.200000E 03	0.976000E 02	0.979050E 01
							0.300000E 03	0.976000E 02	0.979050E 01
							0.400000E 03	0.976000E 02	0.979050E 01
							0.500000E 03	0.976000E 02	0.979050E 01
							0.600000E 03	0.146400E 03	0.979050E 01
17	0.636400E 03	-0.995000E 00	0.120500E 08	0.990207E-01	0.250000E-01	6	0.100000E 03	0.976000E 02	0.979050E 01
							0.200000E 03	0.976000E 02	0.979050E 01
							0.300000E 03	0.976000E 02	0.979050E 01
							0.400000E 03	0.976000E 02	0.979050E 01
							0.500000E 03	0.976000E 02	0.979050E 01
							0.600000E 03	0.146400E 03	0.979050E 01
18	0.636400E 03	-0.995000E 00	0.120500E 08	0.990207E-01	0.250000E-01	6	0.100000E 03	0.976000E 02	0.979050E 01
							0.200000E 03	0.976000E 02	0.979050E 01
							0.300000E 03	0.976000E 02	0.979050E 01
							0.400000E 03	0.976000E 02	0.979050E 01
							0.500000E 03	0.976000E 02	0.979050E 01
							0.600000E 03	0.146400E 03	0.979050E 01
19	0.636400E 03	-0.995000E 00	0.120500E 08	0.990207E-01	0.250000E-01	6	0.100000E 03	0.976000E 02	0.979050E 01
							0.200000E 03	0.976000E 02	0.979050E 01
							0.300000E 03	0.976000E 02	0.979050E 01
							0.400000E 03	0.976000E 02	0.979050E 01
							0.500000E 03	0.976000E 02	0.979050E 01
							0.600000E 03	0.146400E 03	0.979050E 01
20	0.636400E 03	-0.995000E 00	0.120500E 08	0.990207E-01	0.250000E-01	5	0.100000E 03	0.976000E 02	0.979050E 01
							0.200000E 03	0.976000E 02	0.979050E 01
							0.300000E 03	0.976000E 02	0.979050E 01
							0.400000E 03	0.976000E 02	0.979050E 01
							0.500000E 03	0.976000E 02	0.979050E 01
							0.600000E 03	0.146400E 03	0.979050E 01

CABLE NO.2
BJDY

M	STRESSED LEN.	WEIGHT/FT	EXT.RIGIDITY	Y	DRAG CHARACTER	DRAG COE.	RATIO	K	SBAR	WEIGHT	MUE
1	0.636400E 03	-0.995000E 00	0.120500E 08	0.990207E-01	0.990207E-01	0.250000E-01	6	6	0.100000E 03	0.976000E 02	0.979050E 01
									0.200000E 03	0.976000E 02	0.979050E 01
									0.300000E 03	0.976000E 02	0.979050E 01
									0.400000E 03	0.976000E 02	0.979050E 01
									0.500000E 03	0.976000E 02	0.979050E 01
									0.600000E 03	0.146400E 03	0.979050E 01
2	0.636400E 03	-0.995000E 00	0.120500E 08	0.990207E-01	0.990207E-01	0.250000E-01	5	5	0.100000E 03	0.976000E 02	0.979050E 01
									0.200000E 03	0.976000E 02	0.979050E 01
									0.300000E 03	0.976000E 02	0.979050E 01
									0.400000E 03	0.976000E 02	0.979050E 01
									0.500000E 03	0.976000E 02	0.979050E 01
									0.600000E 03	0.146400E 03	0.979050E 01

CABLE NO.3

M	STRESSED LEN.	WEIGHT/FT	EXT. RIGIDITY	Y	DRAG CHARACTER	DRAG COE. RATIO	K	SBAR	WFIGHT	MUE
1	0.636400E 03	-0.995000E 00	0.120500E 08	0.990207E-01	0.250000E-01	5	0.300000E 03 0.400000E 03 0.500000E 03 0.600000E 03	0.976000E 02 0.976000E 02 0.976000E 02 0.146400E 03	0.979050E 01 0.979050E 01 0.979050E 01 0.979050E 01	
2	0.636400E 03	-0.995000E 00	0.120500E 08	0.990207E-01	0.250000E-01	5	0.100000E 03 0.200000E 03 0.300000E 03 0.400000E 03 0.500000E 03 0.600000E 03	0.976000E 02 0.976000E 02 0.976000E 02 0.976000E 02 0.976000E 02 0.146400E 03	0.979050E 01 0.979050E 01 0.979050E 01 0.979050E 01 0.979050E 01 0.979050E 01	
3	0.636400E 03	-0.995000E 00	0.120500E 08	0.990207E-01	0.250000E-01	6	0.100000E 03 0.200000E 03 0.300000E 03 0.400000E 03 0.500000E 03 0.600000E 03	0.976000E 02 0.976000E 02 0.976000E 02 0.976000E 02 0.976000E 02 0.146400E 03	0.979050E 01 0.979050E 01 0.979050E 01 0.979050E 01 0.979050E 01 0.979050E 01	
4	0.636400E 03	-0.995000E 00	0.120500E 08	0.990207E-01	0.250000E-01	6	0.100000E 03 0.200000E 03 0.300000E 03 0.400000E 03 0.500000E 03 0.600000E 03	0.976000E 02 0.976000E 02 0.976000E 02 0.976000E 02 0.976000E 02 0.146400E 03	0.979050E 01 0.979050E 01 0.979050E 01 0.979050E 01 0.979050E 01 0.979050E 01	
5	0.636400E 03	-0.995000E 00	0.120500E 08	0.990207E-01	0.250000E-01	5	0.100000E 03 0.200000E 03 0.300000E 03 0.400000E 03 0.500000E 03 0.600000E 03	0.976000E 02 0.976000E 02 0.976000E 02 0.976000E 02 0.976000E 02 0.146400E 03	0.979050E 01 0.979050E 01 0.979050E 01 0.979050E 01 0.979050E 01 0.979050E 01	
6	0.636400E 03	-0.995000E 00	0.120500E 08	0.990207E-01	0.250000E-01	5	0.100000E 03 0.200000E 03 0.300000E 03 0.400000E 03 0.500000E 03 0.600000E 03	0.976000E 02 0.976000E 02 0.976000E 02 0.976000E 02 0.976000E 02 0.146400E 03	0.979050E 01 0.979050E 01 0.979050E 01 0.979050E 01 0.979050E 01 0.979050E 01	
7	0.636400E 03	-0.995000E 00	0.120500E 08	0.990207E-01	0.250000E-01	5	0.100000E 03 0.200000E 03 0.300000E 03 0.400000E 03 0.500000E 03 0.600000E 03	0.976000E 02 0.976000E 02 0.976000E 02 0.976000E 02 0.976000E 02 0.146400E 03	0.979050E 01 0.979050E 01 0.979050E 01 0.979050E 01 0.979050E 01 0.979050E 01	
8	0.636400E 03	-0.995000E 00	0.120500E 08	0.990207E-01	0.250000E-01	5	0.100000E 03 0.200000E 03 0.300000E 03 0.400000E 03 0.500000E 03 0.600000E 03	0.976000E 02 0.976000E 02 0.976000E 02 0.976000E 02 0.976000E 02 0.146400E 03	0.979050E 01 0.979050E 01 0.979050E 01 0.979050E 01 0.979050E 01 0.979050E 01	

18	0.636400E 03	-0.995000E 00	0.120500E 08	0.990207E-01	0.250000E-01	6	0.300000E 03	0.976000E 02	0.979050F 01
							0.400000E 03	0.976000E 02	0.979050F 01
							0.500000E 03	0.976000E 02	0.979050F 01
							0.600000E 03	0.146400E 03	0.979050F 01
							0.100000E 03	0.976000E 02	0.979050F 01
							0.200000E 03	0.976000E 02	0.979050F 01
							0.300000E 03	0.976000E 02	0.979050F 01
							0.400000E 03	0.976000E 02	0.979050F 01
							0.500000E 03	0.976000E 02	0.979050F 01
							0.600000E 03	0.146400E 03	0.979050F 01
19	0.636400E 03	-0.995000E 00	0.120500E 08	0.990207E-01	0.250000E-01	6	0.100000E 03	0.976000E 02	0.979050F 01
							0.200000E 03	0.976000E 02	0.979050F 01
							0.300000E 03	0.976000E 02	0.979050F 01
							0.400000E 03	0.976000E 02	0.979050F 01
							0.500000E 03	0.976000E 02	0.979050F 01
							0.600000E 03	0.146400E 03	0.979050F 01
20	0.636400E 03	-0.995000E 00	0.120500E 08	0.990207E-01	0.250000E-01	6	0.100000E 03	0.976000E 02	0.979050F 01
							0.200000E 03	0.976000E 02	0.979050F 01
							0.300000E 03	0.976000E 02	0.979050F 01
							0.400000E 03	0.976000E 02	0.979050F 01
							0.500000E 03	0.976000E 02	0.979050F 01
							0.600000E 03	0.146400E 03	0.979050F 01

```

AV(K)= 0.30000E 00
BV(K)= 0.0
AV(K)= 0.30000E 00
BV(K)= 0.0
AV(K)= 0.30000E 00
BV(K)= 0.0

```

EQUILIBRIUM POSITION UNDER GRAVITY FORCES

E= 0.060138550 DELTA= 0.288043976E 00 NO.OF ERROR LOOPS= 41

PIPE AND MAIN BUOY LIFT FORCE COMPONENTS

BUOY BUOYANCY(LBS.)= 40000.00 FZPIP= 2000.

FORCE AND MOTION VALUES FOR KEY SEGMENTS

CABLE NUMBER= 1

SEGMENT NUMBER= 1

FX(M,N)= 0.0
 X(M,N)=-0.740446094E 04
 T(M,N)= 0.197796289E 05

FY(M,N)= 0.0
 Y(M,N)= 0.427508594E 04
 BL(M,N)= 0.637444336E 03

FZ(M,N)= 0.118164063E 01
 Z(M,N)= 0.451675781E 03

SEGMENT NUMBER=20

FX(M,N)= 0.0
 X(M,N)=-0.137207031E 00
 T(M,N)= 0.197637539E 05

FY(M,N)= 0.0
 Y(M,N)=-0.529479980E-01
 BL(M,N)= 0.637443115E 03

FZ(M,N)= 0.419773555E 05
 Z(M,N)= 0.902988672E 04

CABLE NUMBER= 2

SEGMENT NUMBER= 1

FX(M,N)= 0.0
 X(M,N)= 0.389722656E 03
 T(M,N)= 0.197626992E 05

FY(M,N)= 0.0
 Y(M,N)= 0.225034805E 03
 BL(M,N)= 0.637443115E 03

FZ(M,N)= 0.118164063E 01
 Z(M,N)= 0.857857813E 04

SEGMENT NUMBER=20

FX(M,N)= 0.120868633E 05
 X(M,N)= 0.779391406E 04
 T(M,N)= 0.197786250E 05

FY(M,N)= 0.697841406E 04
 Y(M,N)= 0.449988672E 04
 BL(M,N)= 0.637444336E 03

FZ(M,N)=-0.140144102E 05
 Z(M,N)= 0.969238281E-01

CABLE NUMBER= 3

SEGMENT NUMBER= 1

FX(M,N)= 0.0
 X(M,N)=-0.127806962E 00
 T(M,N)= 0.197635586E 05

FY(M,N)= 0.0
 Y(M,N)=-0.450225342E 03
 BL(M,N)= 0.637443115E 03

FZ(M,N)= 0.118164063E 01
 Z(M,N)= 0.857857813E 04

SEGMENT NUMBER=20

FX(M,N)= 0.291442513E 00
 X(M,N)= 0.507181026E-01
 T(M,N)= 0.197794922E 05

FY(M,N)=-0.139573516E 05
 Y(M,N)=-0.899986719E 04
 BL(M,N)= 0.637444336E 03

FZ(M,N)=-0.140150195E 05
 Z(M,N)= 0.101562500E 00

EQUILIBRIUM POSITION UNDER ACTING FORCES

E= 0.611257851E-01 DELTA= 0.144021988E 00
 NO. OF ERROR LOOPS= 132 NO. OF ACCURACY LOOPS= 2
 CURRENT ANGLE= 270.000

FXPIP= 22600. FYP= -3300. FZPIP= 2000.

CABLE NUMBER= 1

SEGMENT NUMBER= 1

FX(M,N)=-0.112474632E 01 FY(M,N)=-0.995558357E 01 FZ(M,N)=-0.116141319E 00
 X(M,N)=-0.740304297E 04 Y(M,N)= 0.427342578E 04 Z(M,N)= 0.451120605E 03
 T(M,N)= 0.398983164E 05 BL(M,N)= 0.638506348E 03
 HORIZL(M,N)= 0.218328953E 01 HEIGHT(M,N)=-0.555175781E 00

SEGMENT NUMBER=20

FX(M,N)= 0.225999688E 05 FY(M,N)=-0.331622656E 04 FZ(M,N)= 0.419770664E 05
 X(M,N)= 0.336240234E 02 Y(M,N)=-0.413435364E 01 Z(M,N)= 0.907864063E 04
 T(M,N)= 0.398461172E 05 BL(M,N)= 0.638503906E 03
 HORIZL(M,N)= 0.340070190E 02 HEIGHT(M,N)=-0.124609375E 01

CABLE NUMBER= 2

SEGMENT NUMBER= 1

FX(M,N)= 0.105526638E 01 FY(M,N)=-0.100876379E 02 FZ(M,N)=-0.401811600E-01
 X(M,N)= 0.427056396E 03 Y(M,N)= 0.203304657E 03 Z(M,N)= 0.857323828E 04
 T(M,N)= 0.306460278E 04 BL(M,N)= 0.636561279E 03
 HORIZL(M,N)= 0.431972961E 02 HEIGHT(M,N)=-0.533984375E 01

SEGMENT NUMBER=20

FX(M,N)= 0.187296436E 04 FY(M,N)= 0.118762817E 04 FZ(M,N)=-0.219029175E 04
 X(M,N)= 0.779413672E 04 Y(M,N)= 0.450003125E 04 Z(M,N)=-0.174316406E 00
 T(M,N)= 0.311702295E 04 BL(M,N)= 0.636564209E 03
 HORIZL(M,N)= 0.265452564E 00 HEIGHT(M,N)=-0.271240234E 00

CABLE NUMBER= 3

SEGMENT NUMBER= 1

FX(M,N)= 0.721258298E-02 FY(M,N)=-0.735249424E 01 FZ(M,N)= 0.311398792E 01
 X(M,N)= 0.319472656E 02 Y(M,N)=-0.455866699E 03 Z(M,N)= 0.857914453E 04
 T(M,N)= 0.164363594E 05 BL(M,N)= 0.637267578E 03
 HORIZL(M,N)= 0.325673676E 02 HEIGHT(M,N)= 0.566406250E 00

SEGMENT NUMBER=20

FX(M,N)=-0.433840485E 02 FY(M,N)=-0.115109375E 05 FZ(M,N)=-0.116526875E 05
 X(M,N)=-0.225820541E-01 Y(M,N)=-0.900003125E 04 Z(M,N)= 0.979003906E-01
 T(M,N)= 0.163795195E 05 BL(M,N)= 0.637264648E 03
 HORIZL(M,N)= 0.179692507E 00 HEIGHT(M,N)=-0.366210938E-02

EQUILIBRIUM POSITION UNDER GRAVITY FORCES

E= 0.045834299 DELTA= 0.352116923E 00 NO.OF ERROK LOOPS= 41

PIPE AND MAIN BUOY LIFT FORCE COMPONENTS

BUOY BUOYANCY(LBS.)= 50000.00 FZPIP= 3500.

FORCE AND MOTION VALUES FOR KEY SEGMENTS

CABLE NUMBER= 1

SEGMENT NUMBER= 1

FX(M,N)= 0.0
X(M,N)= 0.740247656E 04
T(M,N)= 0.248057344E 05

FY(M,N)= 0.0
Y(M,N)= 0.427393750E 04
BL(M,N)= 0.637344238E 03

FZ(M,N)= -0.173920898E 02
Z(M,N)= 0.449237549E 03

SEGMENT NUMBER=20

FX(M,N)= 0.0
X(M,N)= 0.118408203E 00
T(M,N)= 0.250397852E 05

FY(M,N)= 0.0
Y(M,N)= -0.603179932E-01
BL(M,N)= 0.637353271E 03

FZ(M,N)= 0.534436875E 05
Z(M,N)= 0.902711328E 04

CABLE NUMBER= 2

188

SEGMENT NUMBER= 1

FX(M,N)= 0.0
X(M,N)= -0.387760742E 03
T(M,N)= 0.250386016E 05

FY(M,N)= 0.0
Y(M,N)= -0.223885178E 03
BL(M,N)= 0.637353271E 03

FZ(M,N)= -0.173920898E 02
Z(M,N)= 0.857366016E 04

SEGMENT NUMBER=20

FX(M,N)= -0.152379453E 05
X(M,N)= -0.779392578E 04
T(M,N)= 0.248046094E 05

FY(M,N)= 0.879776172E 04
Y(M,N)= 0.449990625E 04
BL(M,N)= 0.637344238E 03

FZ(M,N)= -0.174835156E 05
Z(M,N)= 0.856933594E-01

CABLE NUMBER= 3

SEGMENT NUMBER= 1

FX(M,N)= 0.0
X(M,N)= 0.110247135E 00
T(M,N)= 0.250396875E 05

FY(M,N)= 0.0
Y(M,N)= -0.447966289E 03
BL(M,N)= 0.637353271E 03

FZ(M,N)= -0.173920898E 02
Z(M,N)= 0.857366016E 04

SEGMENT NUMBER=20

FX(M,N)= -0.320621669E 00
X(M,N)= -0.455797799E-01
T(M,N)= 0.248056953E 05

FY(M,N)= -0.175960938E 05
Y(M,N)= -0.89987500E 04
BL(M,N)= 0.637344238E 03

FZ(M,N)= -0.174842891E 05
Z(M,N)= 0.805664063E-01

EQUILIBRIUM POSITION UNDER ACTING FORCES

E= 0.994481444E-01 DELTA= 0.440146029E-01
 NO. OF ERROR LOOPS= 345 NO. OF ACCURACY LOOPS= 2
 CURRENT ANGLE= 270.000

FXPIP= 29100. FYPID= -3500. FZPIP= 3500.

CABLE NUMBER= 1

SEGMENT NUMBER= 1

FX(M,N)= 0.144139862E 01 FY(M,N)=-0.129371052E 02 FZ(M,N)=-0.189511702E 02
 X(M,N)= 0.739786328E 04 Y(M,N)= 0.424291406E 04 Z(M,N)= 0.4276774414E 03
 T(M,N)= 0.305328027E 04 BL(M,N)= 0.636515625E 03
 HORIZL(M,N)= 0.313645630E 02 HEIGHT(M,N)=-0.224631348E 02

SEGMENT NUMBER=20

FX(M,N)= 0.290999102E 05 FY(M,N)=-0.352148584E 04 FZ(M,N)= 0.534433828E 05
 X(M,N)= 0.372941895E 02 Y(M,N)= 0.132705688E 00 Z(M,N)= 0.902246094E 04
 T(M,N)= 0.323316382E 04 BL(M,N)= 0.636522461E 03
 HORIZL(M,N)= 0.371762695E 02 HEIGHT(M,N)=-0.465234375E 01

CABLE NUMBER= 2

SEGMENT NUMBER= 1

FX(M,N)= 0.126952839E 01 FY(M,N)=-0.132972841E 02 FZ(M,N,V)=-0.188610840E 02
 X(M,N)=-0.353729492E 03 Y(M,N)= 0.223139053E 03 Z(M,N)= 0.856987891E 04
 T(M,N)= 0.505438828E 05 BL(M,N)= 0.638324951E 03
 HORIZL(M,N)= 0.340394135E 02 HEIGHT(M,N)=-0.378125000E 01

SEGMENT NUMBER=20

FX(M,N)=-0.309377891E 05 FY(M,N)= 0.179104297E 05 FZ(M,N,V)=-0.354776563E 05
 X(M,N)=-0.779398828E 04 Y(M,N)= 0.450013281E 04 Z(M,N)= 0.172607422E 00
 T(M,N)= 0.503646094E 05 BL(M,N)= 0.638317627E 03
 HORIZL(M,N)= 0.235025108E 00 HEIGHT(M,N)= 0.869140625E-01

CABLE NUMBER= 3

SEGMENT NUMBER= 1

FX(M,N)= 0.907690451E-02 FY(M,N)=-0.103240232E 02 FZ(M,N,V)=-0.151725540E 02
 X(M,N)= 0.354462738E 02 Y(M,N)=-0.449200928E 03 Z(M,N)= 0.857064063E 04
 T(M,N)= 0.214394492E 05 BL(M,N)= 0.637216064E 03
 HORIZL(M,N)= 0.353582764E 02 HEIGHT(M,N)=-0.301953125E 01

SEGMENT NUMBER=20

FX(M,N)=-0.623476410E 02 FY(M,N)=-0.149221250E 05 FZ(M,N,V)=-0.149133594E 05
 X(M,N)=-0.142660141E-01 Y(M,N)=-0.900012109E 04 Z(M,N)=-0.192382813E 00
 T(M,N)= 0.210969609E 05 BL(M,N)= 0.637203369E 03
 HORIZL(M,N)= 0.248077929E 00 HEIGHT(M,N)=-0.272949219E 00

EQUILIBRIUM POSITION UNDER GRAVITY FORCES

E= 0.049543776 DELTA= 0.424811840E 00 ND.OF ERROR LOOPS= 42

PIPE AND MAIN BUOY LIFT FORCE COMPONENTS

BUOY BUOYANCY(LBS.)= 60000.00 FZPIP= 4900.

FORCE AND MOTION VALUES FOR KEY SEGMENTS

CABLE NUMBER= 1

SEGMENT NUMBER= 1

FX(M,N)= 0.0
 X(M,N)= 0.740295703E 04
 T(M,N)= 0.302082930E 05

FY(M,N)= 0.0
 Y(M,N)= 0.427421875E 04
 BL(M,N)= 0.637370361E 03

FZ(M,N)=-0.155673828E 02
 Z(M,N)= 0.449833740E 03

SEGMENT NUMBER=20

FX(M,N)= 0.0
 X(M,N)= 0.798339844E-01
 T(M,N)= 0.304178086E 05

FY(M,N)= 0.0
 Y(M,N)=-0.856781006E-01
 BL(M,N)= 0.637376953E 03

FZ(M,N)= 0.648459453E 05
 Z(M,N)= 0.20781250E 04

CABLE NUMBER= 2

SEGMENT NUMBER= 1

FX(M,N)= 0.0
 X(M,N)=-0.388280518E 03
 T(M,N)= 0.304163750E 05

FY(M,N)= 0.0
 Y(M,N)= 0.224136108E 03
 BL(M,N)= 0.637376953E 03

FZ(M,N)=-0.155673828E 02
 Z(M,N)= 0.857487500E 04

SEGMENT NUMBER=20

FX(M,N)=-0.185330234E 05
 X(M,N)=-0.779396875E 04
 T(M,N)= 0.302069180E 05

FY(M,N)= 0.107001289E 05
 Y(M,N)= 0.44985156E 04
 BL(M,N)= 0.637370361E 03

FZ(M,N)=-0.213188320E 05
 Z(M,N)= 0.429687500E-01

CABLE NUMBER= 3

SEGMENT NUMBER= 1

FX(M,N)= 0.0
 X(M,N)= 0.701087117E-01
 T(M,N)= 0.304177227E 05

FY(M,N)= 0.0
 Y(M,N)=-0.448526367E 03
 BL(M,N)= 0.637376953E 03

FZ(M,N)=-0.155673828E 02
 Z(M,N)= 0.857487500E 04

SEGMENT NUMBER=20

FX(M,N)=-0.464121401E 00
 X(M,N)=-0.115343630E 00
 T(M,N)= 0.302082656E 05

FY(M,N)=-0.214010859E 05
 Y(M,N)=-0.899990234E 04
 BL(M,N)= 0.637370361E 03

FZ(M,N)=-0.213197852E 05
 Z(M,N)= 0.429687500E-01

EQUILIBRIUM POSITION UNDER ACTING FORCES

E= 0.998193622E-01 DELTA= 0.531014800E-01
 NO. OF ERROR LOOPS= 488 NO. OF ACCURACY LOOPS= 2
 CURRENT ANGLE= 270.000

FZPIP= 36600. FYPID= -3700. FZPIP= 4900.

CABLE NUMBER= 1

SEGMENT NUMBER= 1

FX(M,N)= 0.165762711E 01 FZ(M,N)= -0.173504181E 02
 X(M,N)= 0.739926953E 04 Z(M,N)= 0.422726074E 03
 T(M,N)= 0.253153052E 04
 HORIZL(M,N)= 0.400995941E 02 HEIGHT(M,N)= -0.271076660E 02

SEGMENT NUMBER=20

FX(M,N)= 0.365998750E 05 FZ(M,N)= 0.648456289E 05
 X(M,N)= 0.429587402E 02 Z(M,N)= 0.907095313E 04
 T(M,N)= 0.268080103E 04
 HORIZL(M,N)= 0.429720154E 02 HEIGHT(M,N)= -0.685937500E 01

CABLE NUMBER= 2

SEGMENT NUMBER= 1

FX(M,N)= -0.143057442E 01 FZ(M,N)= -0.172192841E 02
 X(M,N)= -0.348560303E 03 Z(M,N)= 0.856877344E 04
 T(M,N)= 0.621374492E 05
 HORIZL(M,N)= 0.397590485E 02 HEIGHT(M,N)= -0.610156250E 01

SEGMENT NUMBER=20

FX(M,N)= -0.380806523E 05 FZ(M,N)= -0.436850234E 05
 X(M,N)= -0.779397656E 04 Z(M,N)= 0.190185547E 00
 T(M,N)= 0.619887305E 05
 HORIZL(M,N)= 0.269644439E 00 HEIGHT(M,N)= 0.147216797E 00

CABLE NUMBER= 3

SEGMENT NUMBER= 1

FX(M,N)= 0.117876492E-01 FZ(M,N)= -0.130735550E 02
 X(M,N)= 0.408260651E 02 Z(M,N)= 0.856971484E 04
 T(M,N)= 0.265850938E 05
 HORIZL(M,N)= 0.407766113E 02 HEIGHT(M,N)= -0.516015625E 01

SEGMENT NUMBER=20

FX(M,N)= -0.891963348E 02 FZ(M,N)= -0.185764336E 05
 X(M,N)= -0.156364441E-01 Z(M,N)= -0.183105469E 00
 T(M,N)= 0.262550781E 05
 HORIZL(M,N)= 0.240401864E 00 HEIGHT(M,N)= -0.226074219E 00

APPENDIX II

A TECHNICAL ECONOMIC ANALYSIS OF
A GAS TRANSMISSION LINE AND THE
PHYSICAL VARIABLES IT OFFERS IN
THE DESIGN AND CONSTRUCTION OF
A SUBMERGED, BUOYANT PIPELINE

by

Pierre Boutin

PETROLEUM ENGINEERING DEPARTMENT
STANFORD UNIVERSITY

January, 1970

INTRODUCTION

OBJECTIVE

The purpose of this research has been to develop an analytical model of a gas pipeline and its pumping stations in order to present:

- 1) The effect of the pressure ratios and pressure profile of the gas over a segment of pipe (between pumping stations) upon buoyancy of the pipeline and, therefore, the forces due to buoyancy exerted on the total structure.
- 2) The pumping station and power requirements for various quantities of gas throughput in various size pipelines in order to eventually relate pumping station investment and pumping costs versus pipe size for various levels of expected rate of product transmission.

SCOPE AND APPROACH

This report has relied heavily upon industry standard procedures developed by the American Gas Association and also acknowledges the advice of the Bechtel Engineering Corporation, San Francisco, California.

The approach has been bounded by several basic assumptions:

- 1) The pipeline route will be from Philippeville, Algeria to Minorca to Marseille, France.
 - 2) Pumping stations will be located only at Philippeville and Minorca; i.e. there will be no stations located at sea.
 - 3) The input pressure at the Philippeville station and the delivered pressure at the input of each pumping station will be 700 psia, an industry accepted practice upon which gas prices are based.
 - 4) The gas gravity for Algerian gas is 0.66 (Bechtel Corporation).
 - 5) The gas temperature is a constant 60^oF maintained by the sea flowing by the pipe. This will, of course, vary seasonably by a few degrees.
 - 6) Pipe thickness can be varied by 0.25 inches for standard pipe in calculations of pipe buoyancy.
 - 7) Compression ratios for individual compressor units should not exceed 1.6 and for compressor stations should not exceed 2.0. These are industry practices recommended by Bechtel Corporation.
 - 8) The water density is a constant 64.0 lbs per cu ft.
- Other assumptions of physical constant are specified in the text where they are introduced.

The flow equations utilized to compute the pressure profile for a pipe section are for partially turbulent

flow (1):

$$Q = (0.0775 \text{ FTB} \cdot \text{FPB} \cdot \text{FGR} \cdot \text{FTT} \cdot \text{FPV}) \\ (\text{FD} \cdot \text{FT} \cdot \text{FF} \cdot \text{FFE}) \left((P_1^2 - P_2^2) / L \right)^{\frac{1}{2}} \quad (\text{Eq. 1})$$

where:

Q = vol. flow rate - MCF/day
FTB = base temperature factor
FPB = base pressure factor
FGR = gas gravity factor
FTF = flowing temperature factor
FPV = super compressibility factor
FD = line diameter factor
FT = transmission factor
FFE = flow efficiency factor
P₁ = upstream pressure - psia
P₂ = downstream pressure - psia
L = line length - miles

and for fully turbulent flow:

$$Q = 0.775 (\text{FTB} \cdot \text{FPB} \cdot \text{FGR} \cdot \text{FTF} \cdot \text{FPV}) \\ (\text{FD}(\text{FDR} + \text{FIR}) \text{FFE} (P_1^2 - P_2^2) / L)^{\frac{1}{2}} \quad (\text{Eq. 2})$$

where: Q, FTB, FPB, FGR, FTF, FPV, FFE, P₁, P₂ and L have the same meaning as in the equation for partially turbulent flow,

FDR = diameter ratio factor

FIR = interior roughness factor

The values of the various F factors in equations 1 and 2 above can be determined from charts, tables and examples in the reference (1). No further efforts will be made here to justify or substantiate this industry accepted method of calculating the pressure profiles related to flow rates, diameters and other variables.

ANALYSIS

1. COMPUTATION OF THE PIPELINE DIAMETER AND THICKNESS REQUIREMENTS AND THE PRESSURE, GAS DENSITY AND BUOYANCY PROFILES ALONG A LONE SECTION FOR A GIVEN FLOW RATE

It is to be noted here that it is a necessary objective of the overall design to have the pipeline be as nearly neutrally buoyant as possible while remaining always positively buoyant. It is assumed here and throughout the design that the most economic method of ballasting the line is by making the thickness of the metal pipe such that any given OD pipe will be as close to neutrally buoyant as possible at the high pressure and using a standard pipe thickness for a given gas pressure profile over the section. Obviously the weight of gas will decrease as the pressure drops along the line and the line buoyancy per foot of line

will increase. Balancing this buoyancy increase is discussed in the main report.

The first objective of this part of the work, therefore, is to find an inside pipe diameter for a given outside diameter of pipe and a given final flow rate of gas such that 1) the pipe section is nearly neutrally buoyant or positively buoyant throughout its length and 2) the compression ratio of 2.0 for each pumping station is not exceeded but nearly equalled.

In order to calculate the input pressure for each section of the pipeline under different conditions of volumetric rate of flow as well as for given external diameter sizes, a computer program has been developed using FORTRAN IV language. The flow chart for this computation is as follows:

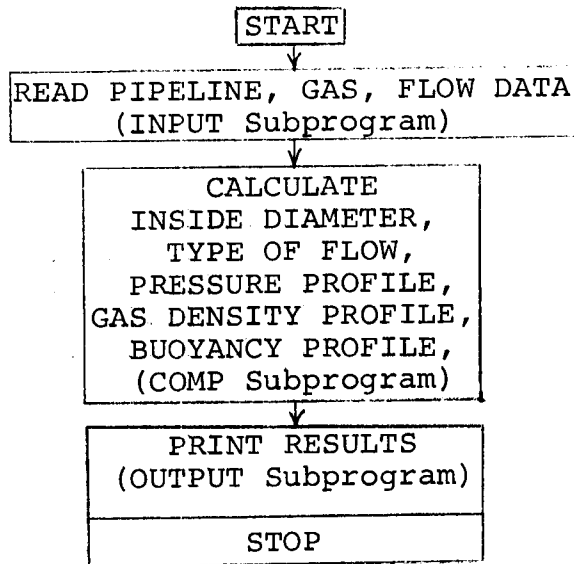

COMPUTATION FLOW CHART

A. Determination of the pipeline inside diameter (ID PIPE).

Conforming to gas industry practice, the output pressure P_2 is always taken to be 700 psia for each section of the line. We need to know the pressure P_1 required at the inlet of each line section in order to maintain P_2 . We need to have the inside diameter of the pipe (IDPIPE) such that the line is as close to neutrally buoyant as possible when the maximum volume of gas it has been designed for flows through it. Hence, for a section of length L miles, and for each given final value of the flow rate Q , (MMSCF/D), we have several proposals to consider with different outside diameter sizes of the pipe, OD , (in). For each outside diameter, first we want to calculate the value of IDPIPE, then, knowing the type of flow, use the proper flow equation from either Eq. 1 or Eq. 2 to develop the significant profiles related to buoyancy along the line: the pressure profile, the gas density profile and finally the buoyancy profile itself.

At the point where the line is the heaviest, which is where the gas density is the greatest or where the highest pressure exists, it must be either neutrally or slightly positively buoyant. This is true at the inlet of the line. For each OD size available on the pipe market, different standard inside diameter sizes are provided. In order to compute which of these values IDPIPE will take, we use an

iteration procedure. Using as a first value for IDPIPE that of the Standard pipe available for that particular OD, we compute the value of the highest pressure in the line, (P1), hence (RO), the density of the gas at the inlet, hence the weight of gas in a one-foot section of the pipe. Knowing the corresponding weight for the pipe, if we add these two weights, we get the vertical downward force acting on a one-foot length of the line. This system is also submitted to the vertical upward Archimedes force. Hence the buoyancy of the system, BU, (LBS/FT), is determined as being the difference between Archimedes force and the two weight forces. It may be expressed as follows:

$$BU \text{ (LBS/FT)} = \frac{\pi}{4 \times 144} (OD^2 (RO_2 - RO_1) - (IDPIPE)^2 (RO - RO_1))$$

(Eq. 3)

where RO_1 and RO_2 are the pipe and the sea-water densities respectively. If we find a negative value for this buoyancy, the pipe is too heavy and we should take the next larger inside diameter available. However, we will arbitrarily reject a thinner pipe than standard line pipe as being unsafe practice. Hence the corresponding OD should not be considered for this flow rate. If, on the other hand, we find a positive buoyancy value this means that the pipe is lighter than it should be for neutral buoyancy of the line, hence we try the next smaller value of inside

diameter available for that ODPIPE as a value for IDPIPE. We continue doing so until we find a negative buoyancy. When such is the case, then we give to IDPIPE the value of the previous value and that is the IDPIPE for which we compute the pressure, density and buoyancy profiles.

Note that in the above Eq. 3, only the value of the gas density ρ_0 is unknown. It may be determined from the value P_1 of the pressure using the state equation of gas:

$$\frac{P_1}{\rho_0} = Z \times R \times (TF) / M \quad (\text{Eq. 4})$$

where:

TF is the temperature of the gas in $^{\circ}\text{K}$

Z the gas compressibility factor

R the universal gas constant, $10.732 \frac{(\text{Lb}/\text{in}^2)(\text{ft}^3)}{(\text{Lb mole})(^{\circ}\text{R})}$

M the molecular weight of the gas.

Since the molecular weight of the gas is simply $G \times$ (molecular weight of air), Eq. 4 yields:

$$\rho_0 = \frac{P_1}{Z} \times \frac{G \times 28.47}{10.732 TF} \quad (\text{Eq. 5})$$

In this equation, we need only compute the values of P_1 and Z, since G and TF are given as constant in our assumptions.

B. Determination of pressure, gas, density and buoyancy
in the line at the inlet (Reference 1)

1) Determination of Flow Type

When the values for L, Q, OD are given and any value for IDPIPE has been chosen, it is necessary to know the type of flow in the pipeline in order to select the appropriate flow equation from Eq. 1 or Eq. 2 from which to determine P1 and Z. The determination of the type of flow is done by computing and comparing the flow Reynolds number (FRN) to the transition Reynolds (TRN). When the flow Reynolds number is greater than or equal to the transition Reynolds number, the flow is said to be "fully turbulent"; otherwise, it is called "partially turbulent".

i) First, the flow Reynolds number (FRN) has to be computed:

$$FRN = \frac{(IDPIPE) \times RO \times C}{12 \times MU} \quad \text{by definition} \quad (Eq. 6)$$

where: C = the mean gas velocity - ft/sec

MU = gas viscosity - lb/ft-sec

Expressing C in terms of Q and IDPIPE, and RO in terms of G we obtain:

$$\begin{aligned}
 \text{FRN} &= \frac{\text{IDPIPE}}{12\text{MU}} \times \frac{\text{PB} \times \text{G} \times 28.47}{10.732 \times \text{TB}} \times \frac{\text{Q} \times 10^6}{24 \times 3600} \times \frac{1}{\frac{\pi}{4} \frac{\text{IDPIPE}^2}{144}} \\
 &= 477.5 \left(\frac{\text{Q}}{\text{MU}} \right) \left(\frac{\text{PB}}{\text{TB}} \right) \left(\frac{\text{G}}{\text{IDPIPE}} \right) \quad (\text{Eq. 7})
 \end{aligned}$$

where: Q = gas flow rate MMSCF/day at the base conditions
of PB and TB

PB = base pressure assumed equal to 14.73 psia.

TB = base temperature, assumed equal to 520 °R (60°F)

G = gas gravity assumed equal to 0.66

Given the gas viscosity MU = 8 x 10⁻⁶ lb/ft-sec the Eq. 7
becomes:

$$\text{FRN} = 59.7\text{Q} \left(\frac{\text{G}}{\text{IDPIPE}} \right) \left(\frac{\text{PB}}{\text{TB}} \right) \quad (\text{Eq. 8})$$

ii) Next, the critical Reynolds number (CRN) is
calculated. It corresponds to the theoretical transition
point from partially to fully turbulent flow in a plot of
transmission factor (FT) versus flow Reynolds number (FRN).
Its value is given by:

$$\text{CRN} = \frac{20.912 (\text{IDPIPE})}{\text{K}} \times \text{LOG} \left[\frac{3.7 (\text{IDPIPE})}{\text{K}} \right] \quad (\text{Eq. 9})$$

Figure 1: Transition Reynolds Number as a Function of Drag Factor and Critical Reynolds Number
 Appendix II

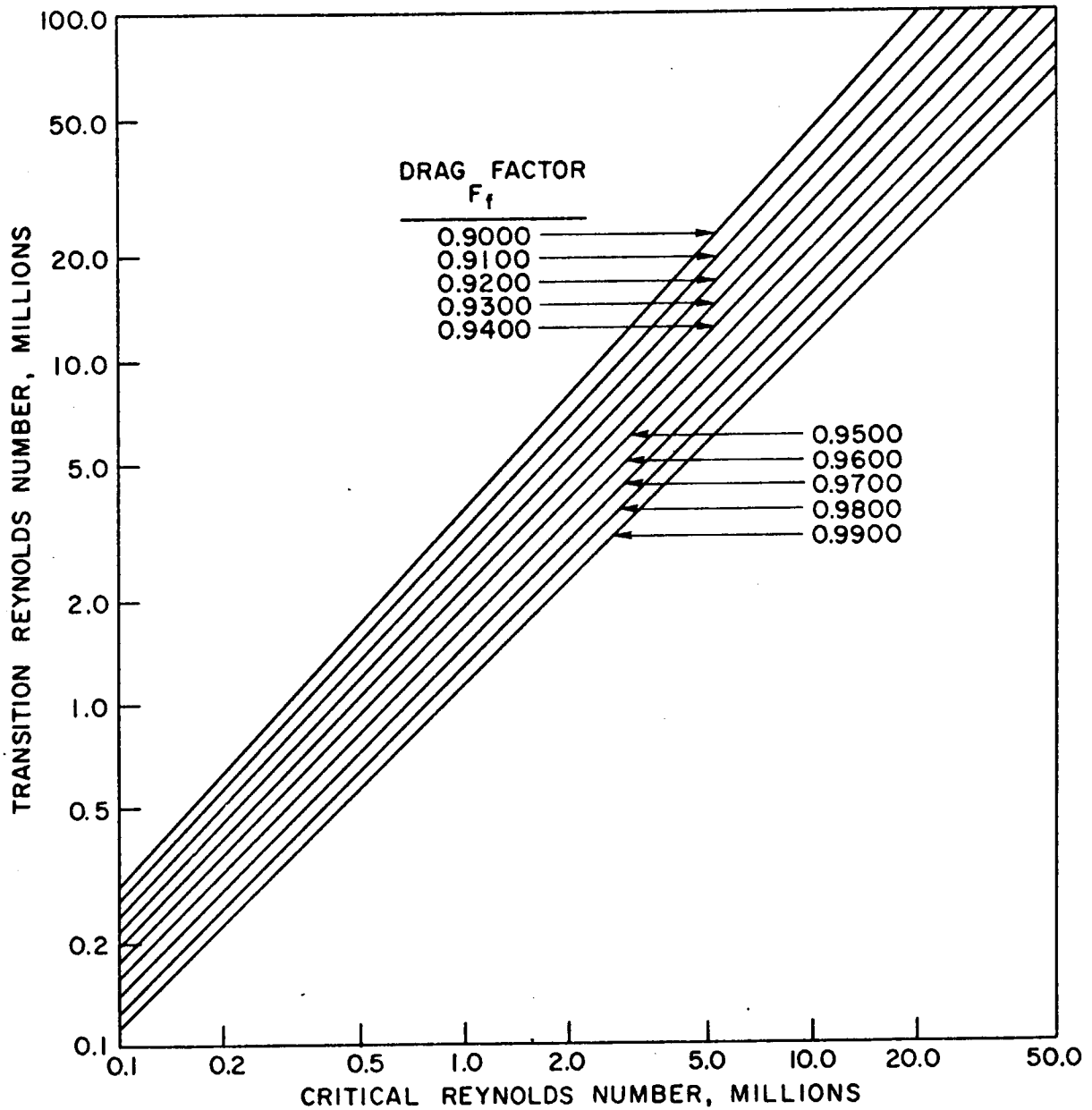

where K is the roughness of the pipeline. K is taken to be 0.25×10^{-3} inches for plastic lined pipe which we will assume for this project.

iii) The final step in determining the flow type is to compute the transition Reynolds number (TRN). The actual transition in type of flow does not occur for the critical Reynolds number (CRN) because drag inducing characteristics exist in the actual pipeline and not in the theoretical case. Thus a drag factor (FF) is introduced in the determination of TRN. For a straight pipeline as postulated for this project, FF is conservatively taken to be 0.97. From Figure 1, a relationship between TRN and CRN may be deduced when $FF = 0.97$:

$$TRN = a \times (CRN)^b + c \quad (\text{Eq. 10})$$

where: $a = 0.706$

$b = 1.04$

$c = 53,350$

A comparison between FRN and TRN will result in the selection of the partially turbulent flow equation (Eq. 1) for $FRN < TRN$ and of the fully turbulent equation (Eq. 2) for $FRN \geq TRN$ in order to determine the value of P1 necessary for any Q, L, IDPIPE and P2 equal 700 psia.

In each case, from the flow equation we may derive a pressure equation by solving it for P1. From the flow

equations, we get:

$$P_1^2 - P_2^2 = LQ^2F$$

$$P_1 = (P_2^2 + LQ^2F)^{\frac{1}{2}} \quad (\text{Eq. 11})$$

where:

$$F = \left[.0775 \times 10^{-3} \left(\frac{TB}{520} \right) \left(\frac{14.73}{PB} \right) (IDPIPE)^{2.5} \left(\frac{FE}{100} \right) \right. \\ \left. (FT) (FF) \right]^2 \left(\frac{0.60}{G} \right) \left(\frac{520}{TF} \right) \left(\frac{1}{Z} \right)$$

for partially turbulent flow and

$$F = \left[.0775 \times 10^{-3} \left(\frac{TB}{520} \right) \left(\frac{14.73}{PB} \right) (IDPIPE)^{2.5} \left(\frac{FE}{100} \right) \times 4 \text{LOG} \frac{3.7 IDPIPE}{K} \right]^2 \\ \left(\frac{0.6}{6} \right) \left(\frac{520}{TF} \right) \left(\frac{1}{Z} \right)$$

for fully turbulent flow.

We see that P_1 is an explicit function of L , Q , and $IDPIPE$. The values given to the parameters P_2 , TB , PB , FF , G , TF , and FE are related directly to the pipeline system itself or to the ocean environment, and are given the constant values already established. For fully turbulent flows only the factor Z is unknown. For partially turbulent flows the factors FF and Z are unknown. Both factors are implicitly related to the main variables L , Q , $IDPIPE$.

2) Z Factor Computation

In order to compute Z, the gas compressibility factor, we need know the actual average pressure in the pipeline (PAV) given by:

$$PAV = \frac{2}{3} (P_1 + P_2 - \frac{P_1 P_2}{P_1 + P_2}) \quad (\text{Eq. 12})$$

Although P₂ has been fixed at 700 psia, P₁ is not yet known. Hence, we can calculate neither PAV nor Z. The procedure followed here is an iteration for the computation of Z, assuming an initial value for PAV independent of Z and equal to P₂ in our method. As long as the new value we get for PAV differs from the previous one by an amount greater than a given error (5 psia has been chosen here and represents less than 1% of the minimum pressure P₂ in the line), then another iteration is done. Otherwise we get an acceptable value for P₁.

Actually Z is not generally a simple function of PAV as stated previously but behaves so in our case because of the special conditions specified. Indeed, Z is a function of the pseudo-reduced temperature (T_R) and of the pseudo-reduced pressure (P_R). These two variables are determined by computing the ratio of the flow temperature and pressure with respect to the pseudo-critical temperature and pressure respectively. The latter two variables are

functions of the gas gravity. Hence we have:

$$Z = f(PR, TR)$$

$$PR = \frac{P(\text{flow})}{PC} = \frac{PF}{PC}$$

$$TR = \frac{T(\text{flow})}{TC} = \frac{TF}{TC}$$

$$PC = f(G)$$

$$TC = f(G)$$

We have a given gas gravity $G = 0.66$ for Algerian gas; therefore, PC and TC are not variables. From NGSMA charts (2) they are: respectively, 670.0 psia and 360 °R.

As seen previously, the P(flow) considered is the average pressure (PAV) in the pipeline. We have assumed the flow temperature reaches an equilibrium value of 520 °R rather rapidly due to the constant bath of the ocean around the pipeline. Therefore, Z is a function of PAV only.

3) FT Factor Computation

FT is an implicit transcendental function of the flow Reynolds number (FRN) and hence of the variables Q and IDPIPE (1):

$$FT = 4\text{LOG}(FRN/FT) - 0.60 \quad (\text{Eq. 13})$$

A trial and error procedure is used to compute FT. Since FT has an order of magnitude of 20, no further precision

than the first decimal digit has been judged necessary.

We now have all the elements necessary to the computation of the pressure P_1 in Eq. 11 for both partially and fully turbulent flows. Hence, we may find the gas density using Eq. 5 and the corresponding buoyancy using Eq. 3, so that we can go ahead with the iteration for the choice of the value of IDPIPE.

C. Determination of the pressure, gas density and system buoyancy profiles along the line

Now that we have determined the best possible value for IDPIPE corresponding to the OD being considered, we are interested in the buoyancy of the line for the ultimate throughput Q as well as for smaller throughputs in the early life of the line when the market is growing. As a simplifying hypothesis two intermediate fractions of the ultimate transmission rate have been chosen in accordance with the industry practice, $Q/2$, and $3Q/4$. For each of the three critical flow rates ($Q/2$, $3Q/4$ and Q) we shall determine the pressure - density - buoyancy (PDB) profiles by computing the pressure, density and buoyancy values at regularly spaced points, every STEPL miles. This is equivalent to holding the end of the line characteristics constant and computing these values for lengths of pipeline of STEPL miles, $2 \times$ STEPL miles, . . . up to L miles. For

each successive length (LX) we shall obtain a set of three values: PX (gas pressure), ROX (gas density), and BUX (pipeline buoyancy/ft). The pressure equation (Eq. 11) may be used if we replace L and P1 by LX and PX respectively. Of course, for each of the three flow rates, we have to find the type of flow first, which has been explained in subsection B.1). Then in subsection B.2) Z and eventually FT in subsection B.3) are computed to reduce the pressure PX corresponding to the length LX. Then Eq. 5 and Eq. 3 will yield the values for ROX and BUX respectively. Now we have available the Pressure - Density - Buoyancy (PDB) profiles for each of the three fractional flow rates for each ultimate flow rate.

The results of this analysis using the computer program from Sub Appendix A are shown in Sub Appendix B for various ultimate flow rates of gas.

D. Relation of section pressures to pumping station compression ratio

Knowing the ratio P_1/P_2 for any pipe section of length L is equivalent to knowing the compression ratio required at the upstream pumping station (SCR) because the input pressure to this station is a constant $P_2 = 700$ psia and its output pressure is P_1 for the section. Appendix A' describes the computer program for determining the value

for IDPIPE, the PDB profiles, the average PDB in the line when shut off, and the compression ratio, $R = P_1/P_2$, at the upstream pumping station for each L, Q, OD considered.

2. COMPUTATION OF COMPRESSOR PLANT REQUIREMENTS

Now that we have, for each case study, the compression ratio that is required for each section, we may proceed computing other characteristics of the line such as the number of compressor units required for each pumping station and the total station horsepower needed.

There are specific industry practices governing the operations of a station and its units: 1) coolers become necessary when the output temperature exceeds 120°F (580°R) and extra power is needed; 2) the engine rating should not be less than 3500 HP; 3) each unit compression ratio should be no more than 1.3 in any case. The overall station compression ratio does not exceed 2.0. If the overall station compression ratio is below 1.5, the temperature rise will be less than 60°F , the output temperature will be less than 120°F for an input temperature of 60°F , and no coolers are required.

Knowing the compression ratio for the station (SCR) the determination of the number of units (N) is given by the following relationship (3):

$$\text{UCR} = (\text{SCR}(1.005)^{N-1})^{1/N} \quad (\text{Eq. 14})$$

With SCR known, a trial and error procedure is used, starting from $N = 1$ and increasing its value until the unit compression ratio (UCR) is 1.3 or below. Then, from SCR and N , we obtain the horsepower needed per MMSCF/D for each case of flow rate Q , diameter OD and length L considered (3).

Each value must be corrected by pressure and temperature correction factors, K_P and K_T (1). Since we assume that the inlet temperature is 60°F , $K_T = 1.0$. Taking the inlet pressure to be 700 psia, $K_P = 0.90$ ($K_P = 1.0$ for 0 psia).

The corrected value of power required in HP/MMSCF/day, FUHP, multiplied by the throughput gives the total power need, THP. Hence dividing this value by the number of units, we get the horsepower per unit, UHP. By industry practice (Bechtel) this value should not be less than 3500 HP, even if it is not required to maintain a maximum unit compression ratio of 1.3.

REFERENCES

1. American Gas Association, Steady State Flow Computation Manual For Natural Gas Transmission Lines, 1964, Library of Congress No. 64-66144.
2. Natural Gasoline Supply Men's Association, Engineering Data Book, Seventh Edition 1957, Tulsa, Oklahoma.
3. De Laval Steam Turbine Company, Centrifugal Pipeline Compressor Manual, April, 1961, New Jersey.

SUB APPENDIX A

Description Of The Computer Program To Determine The Pressure Requirements

Now we know the procedure to follow, we can show a precise flow chart of the actual process of the computation for one set of variables L, Q, OD.

1. INPUT Subroutine

By calling the INPUT subroutine, (see Sub Appendix B) the values of AMAX, BMAX and CMAX are read. Three integers represent the total number of values of L, Q, and OD that we are going to study. These three integers are on the first data card.

The second step is to read the various parameters discussed previously. They are

STEPL = spacing of points for profiles
R01 = density of pipe
R02 = density of salted water
G = gas gravity
PB = base pressure
TB = base temperature
K = pipe roughness
P2 = downstream pressure

PC = pseudo-critical pressure for G
TC = pseudo-critical temperature for G
TF = temperature of the gas flow
FE = flow efficiency
FF = drag factor

For the presented computations we have assumed values for all of these parameters in the program. These values are included in the program under the following nomenclature: STEPLO, ROLO, ROZO, GO, PBO, TBO, KO, P20, TCO, TFO, FEO, FFO, and are set to the assumed values if the values read from the data cards are 0. . There is one card per parameter. Hence, if all the assumptions are satisfactory, 13 cards must be input with 0.; otherwise, the new value has to be specified in place of 0. . These values form the Block Data Subprogram.

The third step is to read the variables: AMAX values for L, BMAX for Q, CMAX for OD. These variables are one-dimensional arrays. For L(A), the program allows for computations up to AMAX = 3, and A is the array parameter. For Q(B), it allows for computations up to BMAX = 5, and B is the array parameter. For OD(C), it allows for computations up to CMAX = 10, and C is the array parameter. For each OD(C) read, ten possible corresponding values of IDPIPE are computed and stored in the two-dimensional array ID(C,D). In order to do so, the IDSUB Subprogram is

called:

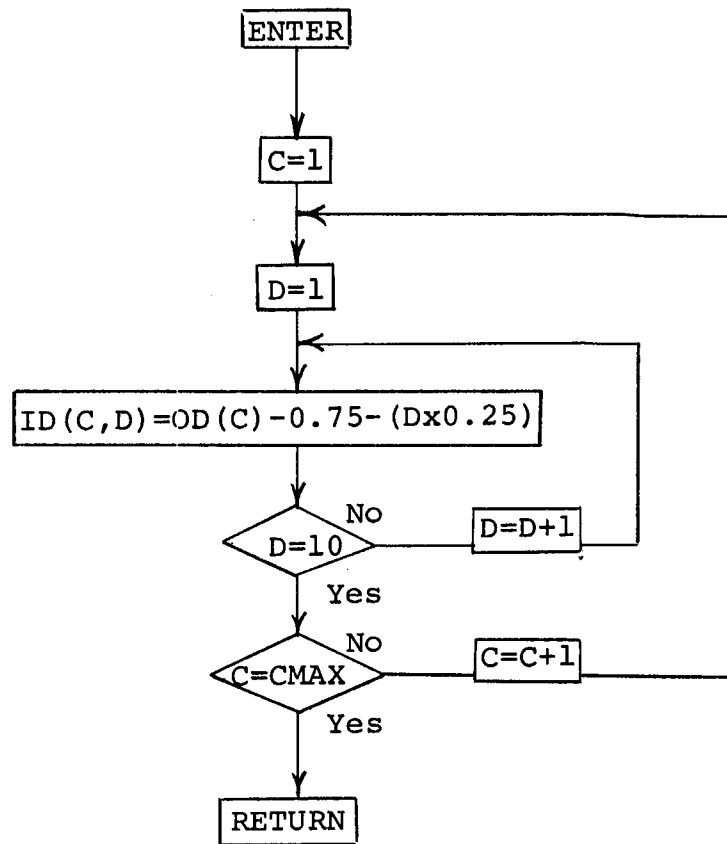

Figure (A1) IDSUB Subprogram

2. COMP Subprogram

This subprogram is called to determine IDPIPE and then compute the PDB profiles corresponding to Q(B).

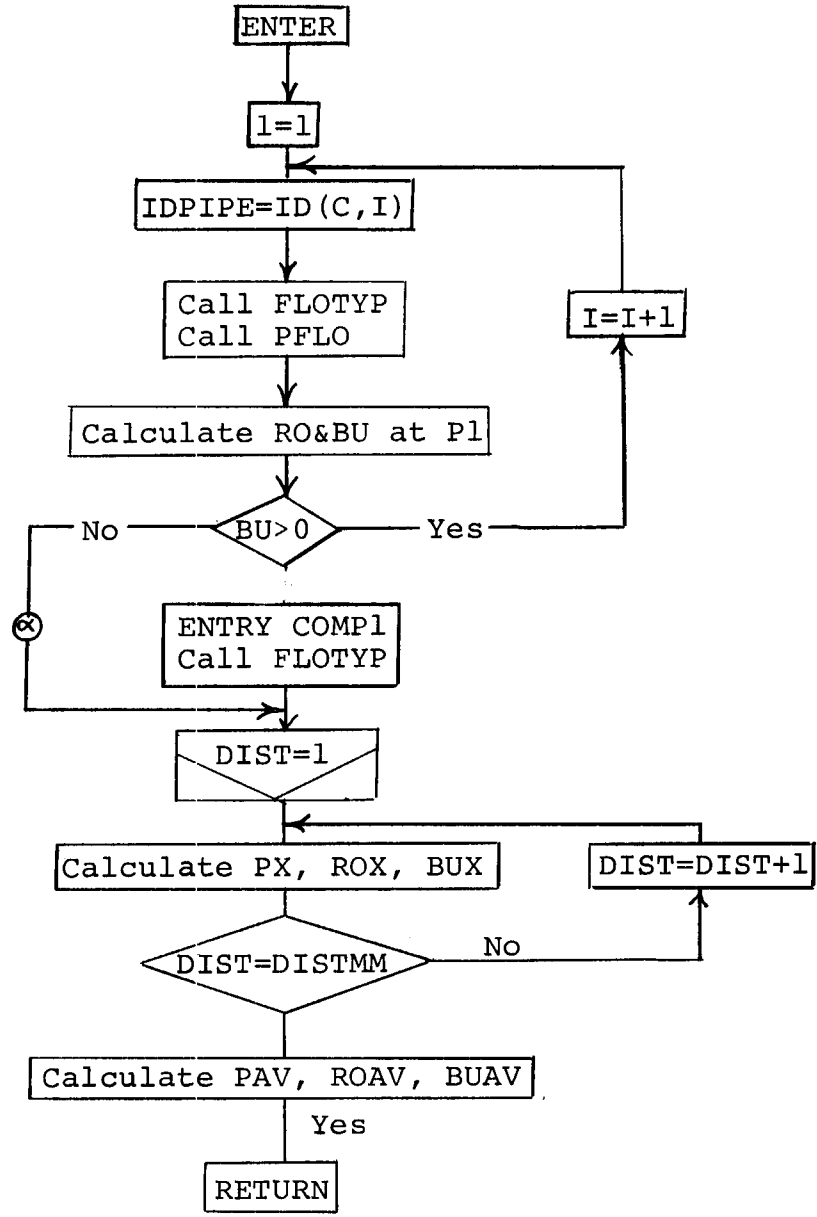

Figure (A2) COMP Subprogram

The first part of the subroutine, down to α , implements the computations in section 1A of the analysis. Note that the type of flow is determined in FLOTYP subroutine, P1 value

in PFLO subroutine, RO value in ROSUB function subprogram, and BU value in the BUSUB function statement. The next call for FLOTYP subprogram is skipped. FLOTYP and PFLO subprograms are explained further in this appendix.

The second part of COMP subroutine computes the Pressure-Density-Buoyancy (PDB) values for DISTMM points along the line and the PDB average values for the line by using PFLO, ROSUB and BUSUB respectively. The corresponding DISTMM lengths LX are determined by $LX(DIST) = (DIST-1) \times STEPL$. DISTM is the largest number of times L(A) contains STEPL miles. The value L(A) is given to LX(DISTEMM) where $DISTMM = DISTM + 1$.

3. Main Program

The corresponding diagram is presented in Figure A3. After calling INPUT, the program enters the three loops on the L, Q, and OD arrays. For each set of three values, COMP is called and then the OUTPUT subprogram, then; keeping the same IDPIPE value, the PDB profiles are computed by calling COMPl. COMPl is the part of COMP dealing with the profiles computation, a first time for a flow rate of $Q(B)/2$, and a second time for $Q(B) \times 3/4$. OUTPUT is called immediately after each profile determination.

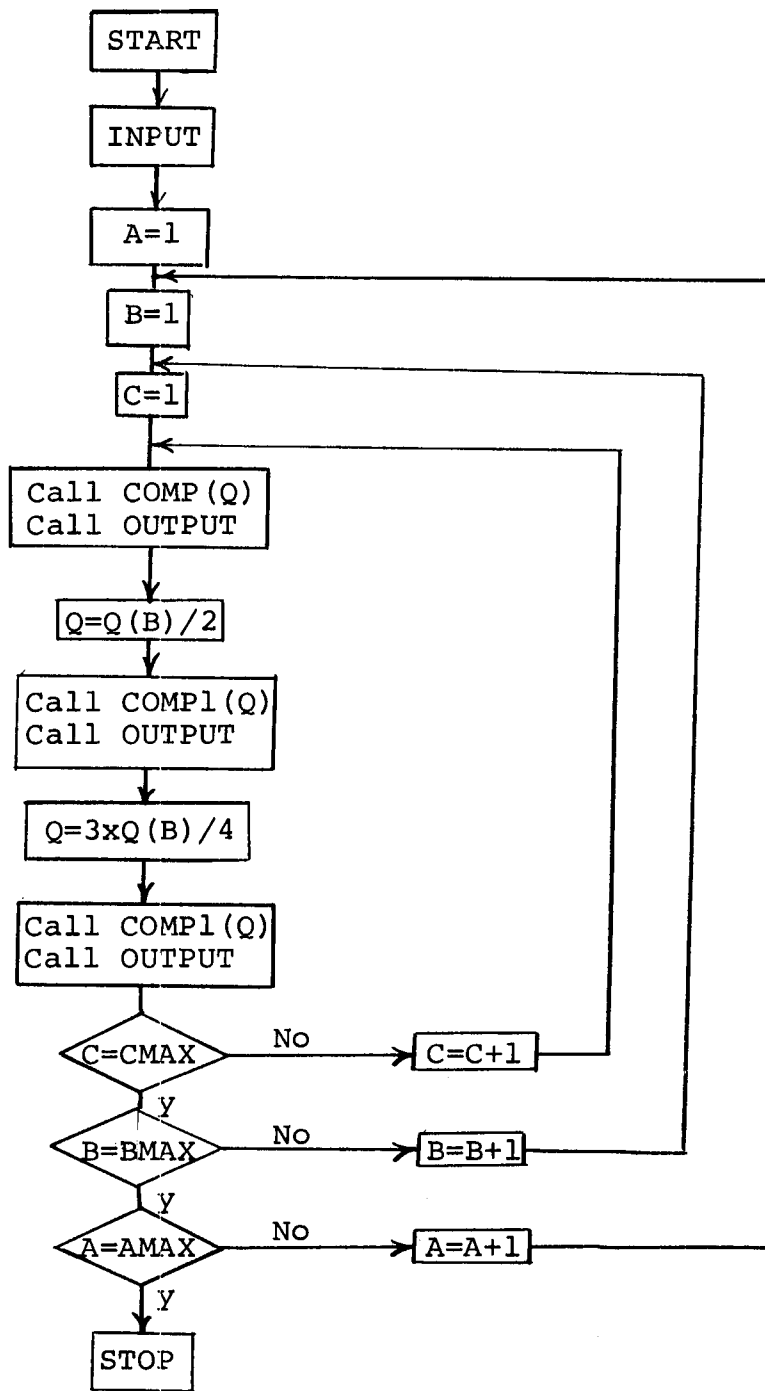

Figure (A3) Main Program

4. FLOTYPE Subprogram

This subprogram executes the calculation presented in section 1.2. computing and comparing the three Reynolds numbers FRN, CRN, TRN and sets an integer FLO to 1 for partially turbulent flow and to 2 for fully turbulent flow. The value of FLO indicates the proper pressure equation in PFLO. This is FLOTYP diagram:

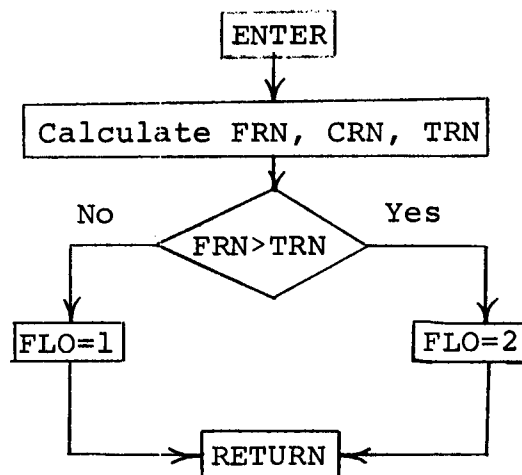

Figure (A4) FLOTYP Subprogram

5. PFLO Subprogram

This program executes the pressure calculations presented in section B.1) of the text. First, PAV is set equal to P2. Then the iterations on Z, the pressure value and PAV are accomplished until PAV does not change more than 5 psia. ZSUB and FTSUB are called to compute the values of the Z factor and of the transmission factor FT when FLO=1 (partially turbulent flow).

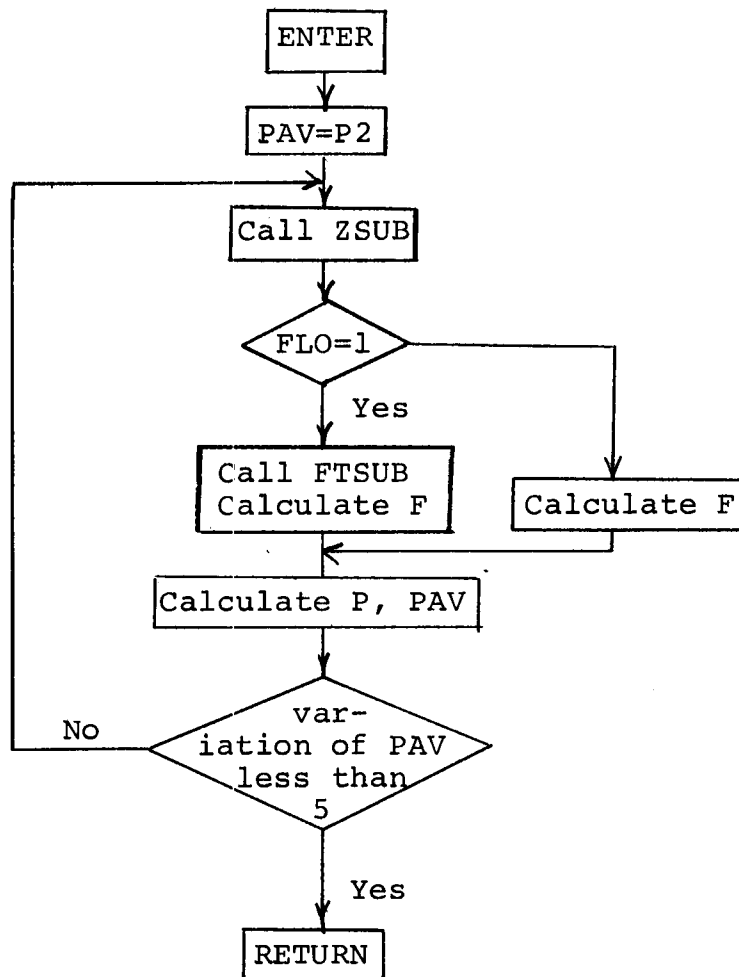

Figure (A5) PFLO Subprogram

6. ZSUB Subprogram

The method developed by Sarem (4) and using polynomials up to fifth degree is applied. The flow chart describing the procedure is shown below:

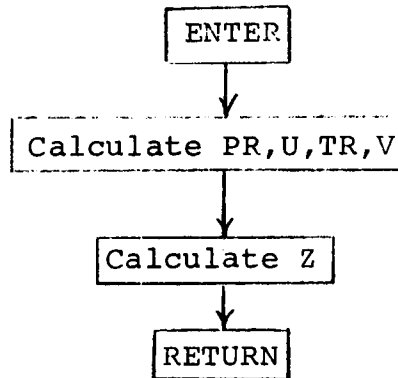

Figure (A6) ZSUB Subprogram

where U and V are functions of PR and TR respectively as defined in (1).

$$\text{Then } Z = \sum_{i=1}^6 \sum_{j=1}^6 \text{COEF}(i;j) \times \text{POLSUB}(i,V) \times \text{POLSUB}(j,U)$$

The polynomials are listed in POLSUB subprogram

7. FTSUB Subprogram

A trial and error procedure is used as explained in section B.3) of the text. In Equation 13, knowing the value for FRN, the initial value for FT is set equal to 0.0.

Then the increments are considered as follows:

10.0, 1.0, 0.1

8. OUTPUT Subprogram

When OUTPUT₂ is called it first prints the values of L, Q, OD, IDPIPE under study, then the tableau of the profiles, with LX, PX, ROX, BUX in the 1st, 2nd, 3rd and 4th column respectively, and finally, the PDB average conditions in the line for the specified values of the variables.

A sample of printed results is given in Sub Appendix B.

SUB APPENDIX B

```

$WATFOR
C
C
C
C THIS PROGRAM IS BY PIERRE L BOUTIN D'AGUESSEAU
C IT IS TO COMPUTE PRESSURE PROFILE AND POWER REQUIREMENTS
C FOR A TRANSMEDITERRANEAN SUBMERGED NEUTRALLY-BUOYANT
C NATURAL GAS PIPELINE FOR VARIOUS VOLUME CONDITIONS.
C
C
C
C
C MAIN PROGRAM
C
C
C
C
1 COMMON /COM1/ A,AMAX,B,BMAX,C,CMAX,D,L,Q,OD,ID
2 COMMON /COM4/ IDPIPE,LX,PX,RDX,BUX,DISTMM
3 COMMON /COM2/ STEPL,RO1,RO2,G,PB,TB,K,P2,PC,TC,TF,FE,FF
4 COMMON /COM3/ STEPLO,RO1O,RO2O,GO,PBO,TBO,KO,P2O,PCO,TCO,TFO,FEO,
1 FFO
5 REAL IDPIPE
6 REAL L(3),Q(5),OD(10),ID(10,10),LX(100),PX(100),RDX(100),BUX(100)
7 REAL*8 ZZ
8 INTEGER A,AMAX,B,BMAX,C,CMAX,D,DIST,DISTM,DISTMM,FLO
9 CALL INPUT
10 DO 1 A = 1,AMAX
11 DO 1 B = 1,BMAX
12 DO 1 C = 1,CMAX
13 CALL COMP ( L(A),Q(B),OD(C),ID,C,&1)
14 CALL OUTPUT ( L(A),Q(B),OD(C) )
15 VQ = Q(B)/2.
16 CALL COMP1 (L(A),VQ,OD(C))
17 CALL OUTPUT (L(A),VQ,OD(C))
18 VQ = Q(B)*3./4.
19 CALL COMP1 (L(A),VQ,OD(C))
20 CALL OUTPUT (L(A),VQ,OD(C))
21 1 CONTINUE
22 2 CONTINUE
23 STOP
24 END
C
C
C
C

```



```

25      SUBROUTINE INPUT
      C
      C
      C
26      COMMON /COM1/ A,AMAX,B,BMAX,C,CMAX,D,L,Q,OD,ID,
      1 IDPIPE,LX,PX,ROX,BUX,DISTMM
27      COMMON /COM2/ STEPL,RO1,RO2,G,PB,TB,K,P2,PC,TC,TF,FE,FF
28      COMMON /COM3/ STEPLO,RO1O,RO2O,GO,PBO,TBO,KO,P2O,PCO,TCO,TFO,FEO,
      1 FFO
29      REAL IDPIPE
30      INTEGER A,AMAX,B,BMAX,C,CMAX,D,DIST,DISTM,DISTMM,FLO
31      REAL L(3),Q(5),OD(10),ID(10,10),LX(100),PX(100),ROX(100),BUX(100)
32      READ 11 , AMAX,BMAX, CMAX
33      11 FORMAT(3I2)
      C AMAX IS THE NUMBER OF PIPELINE SECTIONS CONSIDERED
      C BMAX IS THE NUMBER OF FINAL FLOW RATES CONSIDERED
      C CMAX IS THE NUMBER OF OUTSIDE DIAMETERS CONSIDERED
34      READ 12 , STEPL, RO1, RO2, G, PB, TB, K, P2, PC, TC, TF, FE, FF
35      12 FORMAT(F80.2)
      C STEPL (10. MILES IF 0)
36      IF (STEPL.EQ.0) STEPL= STEPLO
      C DENSITY RO1 OF PIPE (490. LBS/CFT IF 0)
37      IF (RO1.EQ.0) RO1=RO1O
      C DENSITY RO2 OF SALTED WATER (0.64 LBS/CFT IF 0)
38      IF (RO2.EQ.0) RO2= RO2O
      C SPECIFIC GRAVITY OF NATURAL GAS (0.66 IF 0)
39      IF (G.EQ.0) G= GO
      C
40      IF (PB.EQ.0) PB= PBO
      C
41      IF (TB.EQ.0) TB= TBO
      C
42      IF (K.EQ.0) K= KO
      C
43      IF (P2.EQ.0) P2= P2O
      C
44      IF (PC.EQ.0) PC= PCO
      C
45      IF (TC.EQ.0) TC= TCO
      C
46      IF (TF.EQ.0) TF= TFO
      C
47      IF (FE.EQ.0) FE= FEO
      C
48      IF (FF.EQ.0) FF= FFO
49      DO 1 A = 1,AMAX
50      1 READ 12 ,L(A)
51      DO 2 B = 1,BMAX
52      2 READ 12 ,Q(B)
53      DO 3 C = 1,CMAX
54      READ 12 ,OD(C)
55      CALL IDSUB(OD(C),C, ID)
56      3 CONTINUE
57      RETURN
58      END
      C
      C
      C
      C

```

```

59      SUBROUTINE COMP (VL,VQ,VOD,I,C,*)
      C
      C
      C
60      COMMON /COM2/ STEPL,RO1,RO2,G,PB,TB,K,P2,PC,TC,TF,FF,FF
61      COMMON /COM4/ IDPIPE,LX,PX,ROX,BUX,DISTM,PAV,ROAV,BUAV
62      INTEGER A,AMAX,B,BMAX,C,CMAX,D,DIST,DISTM,DISTMM,FLO
63      REAL L(3),Q(5),OD(10),ID(10,10),LX(100),PX(100),ROX(100),BUX(100)
64      REAL IDPIPE,K
65      PAVSUB(PA,PB) = 2./3.*( PA+PB - PA*PB/(PA+PB) )
66      BUSUB(VOD,VID,VRO,VRO1,VRO2) =
1      ( (VRO2-VRO1)*VOD*VOD + (VRO1-VRO)*VID*VID ) * 3.14159/576.
67      DISTM = VL/STEPL + 1
68      DISTMM = DISTM + 1
69      LX(DISTMM) = VL
70      DO 1 I = 1,10
71      IDPIPE = ID(C,I)
72      CALL FLOTYP(VQ,IDPIPE,G,PB,TB,K,FLO,FRN)
73      CALL PFLO(VL,VQ,IDPIPE,FRN,FLO,P,&5)
74      PX(DISTMM) = P
75      ROX(DISTMM) = ROSUB(PX(DISTMM))
76      BUX(DISTMM) = BUSUB(VOD,IDPIPE,ROX(DISTMM),RO1,RO2)
77      IF (BUX(DISTMM).LT.0.) GO TO 2
78      1 CONTINUE
79      2 IF (I.GT.1) GO TO 3
80      IDPIPE = ID(C,1)
81      PRINT 21,VL,VQ,VOD
82      21 FORMAT('0','WARNING FROM COMPUT: FOR L= ',F5.1,' ,Q= ',F5.1,
1      ' AND OD= ',F4.1, / , 'THERE IS NO ID WE CONSIDER',
2      ' LARGE ENOUGH TO MAKE THE LINE BUOYANT.',
3      / , 'PROGRAM WAS SENT TO NEXT COMPUTATION.')
```

83 GO TO 6

84 RETURN 1

*WARNING** ST-4

```

85      3 I = I-1
86      IDPIPE = ID(C,I)
87      6 GO TO 7
88      ENTRY COMP1 (VL,VQ,VOD)
89      CALL FLOTYP(VQ,IDPIPE,G,PB,TB,K,FLO,FRN)
90      7 CONTINUE
91      DO 4 DIST = 1,DISTM
92      LX(DIST) = (DIST-1)*STEPL
93      CALL PFLO(LX(DIST),VQ,IDPIPE,FRN,FLO,P,&5)
94      PX(DIST) = P
95      ROX(DIST) = ROSUB(PX(DIST))
96      BUX(DIST) = BUSUB(VOD,IDPIPE,ROX(DIST),RO1,RO2)
97      4 CONTINUE
98      DISTMM = DISTM + 1
99      LX(DISTMM) = VL
100     CALL PFLO(LX(DISTMM),VQ,IDPIPE,FRN,FLO,P,&5)
101     PX(DISTMM) = P
102     ROX(DISTMM) = ROSUB(PX(DISTMM))
103     BUX(DISTMM) = BUSUB(VOD,IDPIPE,ROX(DISTMM),RO1,RO2)
104     PAV = PAVSUB(P2,PX(DISTMM))
105     ROAV = ROSUB(PAV)
106     BUAV = BUSUB(VOD,IDPIPE,ROAV,RO1,RO2)
107     RETURN
108     5 RETURN 1
109     END
```

```

110      SUBROUTINE FLOTYP(VQ,VID,VG,VPB,VTB,VK,FLO,FRN)
      C
      C
      C
111      INTEGER FLO
112      FRNSUB(VQ,VID,VG,VPB,VTB) = 59.7*VQ/VID*VG*VPB/VTB*1.E6
113      CRNSUB(VID,VK) = 20.912*VID/VK*ALOG10(3.7*VID/VK)
114      TRNSUB(VCRN) = .706*VCRN**1.04 + 53350.
115      FRN = FRNSUB(VQ,VID,VG,VPB,VTB)
116      CRN = CRNSUB(VID,VK)
117      TRN = TRNSUB(CRN)
118      IF (FRN.GT.TRN) GO TO 1
      C
      C PARTIALLY TURBULENT FLOW
      C
119      FLO = 1
120      RETURN
      C
      C FULLY TURBULENT FLOW
      C
121      1 FLO = 2
122      RETURN
123      END
      C
      C
      C

```

```

124      SUBROUTINE PFLO(VL,VQ,VID,VFRN,FLO,P,*)
      C
      C
      C
125      COMMON /COM2/ STEPL,RO1,RO2,G,PB,TB,K,P2,PC,TC,TF,FE,FF
126      INTEGER A,AMAX,B,BMAX,C,CMAX,D,DIST,DISTM,DISTMM,FLO
127      REAL*8 ZZ
128      PSUB(VL,VQ,VF,VP) = SQRT(VP*VP + VL*VQ*VQ/VF)
129      PAVSUB(PA,PB) = 2./3.*( PA+PB - PA*PB/(PA+PB) )
130      PAV = P2
131      DO 5 I = 1,10
132      1 CALL ZSUB(PC,TC,TF,PAV,ZZ)
133      Z = ZZ
134      GO TO (2,3),FLO
135      2 CALL FTSUB(VFRN,FT,&8)
136      F = 1 / ( Z*G/.6*TF/520.* ( PB/14.73*520.E6/TB/.775/ VID**2.5
1      /FE/FT/FF)**2 )
137      GO TO 4
138      3 F = 1 / ( Z*G/.6*TF/520.* ( PB/14.73*520.E6/TB/3.1 / VID**2.5
1      /FE/ALOG10(3.7*VID/K) )**2 )
139      4 DUMP = PSUB(VL,VQ,F,P2)
140      MIN = PAV - 5.
141      MAX = PAV + 5.
142      PAV = PAVSUB(P2,DUMP)
143      IF ( (MIN.LT.PAV).AND.(PAV.LT.MAX) ) GO TO 7
144      5 CONTINUE
145      PRINT 13,VL,VQ,VID,VFLO
146      13 FORMAT('0','10 LOOPS MADE IN PFLO FOR VL= ',F5.1,' ,VQ= ',F5.1,
1      ' ,ID= ',F4.1,' (FLO= ',I1,' )' )
147      7 P = DUMP
148      RETURN
149      8 RETURN 1
150      END

```

C
C
C
C

```

151      FUNCTION ROSUB(VP)
      C
      C
      C
152      COMMON /COM2/ STEPL,R01,R02,G,PB,TB,K,P2,PC,TC,TF,FE,FF
153      REAL*8 ZZ
154      CALL ZSUB(PC,TC,TF,VP,ZZ)
155      Z = ZZ
156      ROSUB = VP*G*28.97/Z/10.732/TF
157      RETURN
158      END
      C
      C
      C
      C

```

```

159          SUBROUTINE FTSUB(VFRN,FT,*)
          C
          C
          C
160          FTFRN(X) = X*10.**((X+.60)/4.)
161          I = 1
162          J = 1
163          K = 1
164          FT = 0.
165          VFT = C.
166          1 A = FTFRN(FT)
167          IF (A-VFRN) 2,11,3
168          2 I = I+1
169          IF (I.GT.4) GO TO 9
170          VFT = FT
171          FT = FT+10.0
172          GO TO 1
173          3 FT = VFT
174          4 A = FTFRN(FT)
175          IF (A-VFRN) 5,11,6
176          5 J = J+1
177          IF (J.GT.11) GO TO 9
178          VFT = FT
179          FT = FT + 1.0
180          GO TO 4
181          6 FT = VFT
182          7 A = FTFRN(FT)
183          IF (A-VFRN) 8,11,11
184          8 K = K+1
185          IF (K.GT.11) GO TO 9
186          FT = FT + .1
187          GO TO 7
188          9 PRINT 14,I,J,K
189          14 FORMAT('0','FTSUB IN ERROR: I= ',I1,' ,J= ',I2,' ,K= ',I2,
1          1 ' ,PROGRAM WAS STOPPED.')
190          RETURN 1
191          11 CONTINUE
192          RETURN
193          END
          C
          C
          C
          C

```

```

194      SUBROUTINE ZSUB(VPC,VTC,VTF,VP,ZZ)
      C
      C
      C
195      REAL*8 COEF(6,6)/
      1  2.1433504,      0.33123524,      0.10572871,
      2  -0.052184040,   0.019703980,   -0.0053095900,
      3  0.083176184,    -0.13403614,   -0.050393654,
      4  0.044312146,    -0.026383354,   0.0089178330,
      5  -0.021467042,   0.066880961,   0.0050924798,
      6  -0.019329465,   0.019262143,   -0.010894821,
      7  -0.00087140318, -0.027174261,   0.010551336,
      8  0.0058972516,   -0.01153539,    0.009559389,
      9  0.0042846283,   0.0088512291,   -0.0073181933,
      1  0.0015366676,   0.0042910089,   -0.0060114017,
      2  -0.0016595343,  -0.0021520929,   0.0026959963,
      3  -0.0028326809,  -0.00081302526,   0.0031175170/,
      4  ZZ,POLSUB
196      PR = VP/VPC
197      TR = VTF/VTC
198      IF ( (PR.LT..1.OR.14.9.LT.PR).OR.(TR.LT.1.C5.OR.2.95.LT.TR) )
199      1 PRINT 15,PR,TR
      15 FORMAT('0','THE RANGE FOR PR VALUES IS .1 TO 14.9 AND PR= ',
      2 F5.2,'0','THE RANGE FOR TR VALUES IS 1.05 TO 2.95 AND TR= ',
      2 F5.2,'0',' ,Z IS IN ERROR. ')
200      U = (2.*PR - 15.)/14.8
201      V = (2.*TR - 4.)/1.9
202      ZZ = .0
203      DO 2 I = 1,6
204      DO 1 J = 1,6
205      ZZ = ZZ + COEF(I,J)*POLSUB(I,V)*POLSUB(J,U)
206      1 CONTINUE
207      2 CONTINUE
208      RETURN
209      END
      C
      C
      C

```

```

210      FUNCTION POLSUB(K,W)
      C
      C
      C
211      IMPLICIT REAL*8 (A-H,O-Q)
212      GO TO (1,2,3,4,5,6),K
213      1 POLSUB = .7071068
214      RETURN
215      2 POLSUB = 1.224745*W
216      RETURN
217      3 POLSUB = .7905695*(3*W**2 - 1)
218      RETURN
219      4 POLSUB = .9354145*(5*W**3 - 1)
220      RETURN
221      5 POLSUB = .265165*(35*W**4 - 30*W**2 + 3.)
222      RETURN
223      6 POLSUB = .293151*(63*W**5 - 70*W**3 + 15*W)
224      RETURN
225      END
      C
      C
      C
      C

```



```

226          SUBROUTINE IDSUB(VOD,C,IO)
          C
          C
          C
227          INTEGER A,AMAX,B,BMAX,C,CMAX,D,DIST,DISTM,DISTMM,FLD
228          REAL ID(10,10)
229          DO 1 D = 1,10
230          ID(C,D) = VOD - .75 - D*.25
231          1 CONTINUE
232          RETURN
233          END
          C
          C
          C
          C

```

```

234      SUBROUTINE OUTPUT(VL,VQ,VDD)
      C
      C
      C
235      COMMON /COM2/ STEPL,RD1,RD2,G,PB,TB,K,P2,PC,TC,TF,FE,FF
236      COMMON /COM4/ IDPIPE,LX,PX,ROX,BUX,DISTMM,PAV,RJAV,BUAV
237      INTEGER A,AMAX,B,BMAX,C,CMAX,D,DIST,DISTM,DISTMM,FLD
238      REAL IDPIPE
239      REAL L(3),Q(5),OD(10),ID(10,10),LX(100),PX(100),ROX(100),BUX(100)
240      PRINT 31,VL,VQ,VDD,IDPIPE
241      31 FORMAT('1',50X,'RESULTS FOR L= ',F5.1,' ,Q= ',F6.1,' ,DD= ',F5.2,
1          ' ,ID= ',F5.2)
242      DO 1 DIST = 1,DISTMM
243      DL = VL-LX(DIST)
244      PRINT 32,DL,PX(DIST),ROX(DIST),BUX(DIST)
245      32 FORMAT( /,25X,'L= ',F5.1,20X,' , P= ',F6.1,' ,RO= ',F6.2,
1          ' ,BU= ',F6.2)
246      1 CONTINUE
247      PRINT 33,PAV,RJAV,BUAV
248      33 FORMAT(/,25X,'AVERAGE PRESSURE IN SECTION WOULD BE ',F6.1,
1          /,25X,'AVERAGE DENSITY IN SECTION WOULD BE ',F6.2,
2          /,25X,'AVERAGE BUOYANCY IN SECTION WOULD BE ',F6.2)
249      RETURN
250      END
      C
      C
      C

```

```

251      BLOCK DATA
      C
      C
      C
252      COMMON /COM3/ STEPLO,RD10,RD20,GO,PB0,TB0,K0,P20,PC0,TC0,TF0,FE0,
      1      FFC
253      REAL STEPLO/10./,RD10/490./,RD20/64./,GO/.66/,PB0/14.73/,
      1      TB0/520./,K0/.25E-3/,P20/700./,PC0/670./,TC0/360./,TF0/520./,
      2      FE0/100./,FF0/.97/
254      END
      C
      C
      C
      C
      C      DATA
      C
      C
      C
      $DATA

```

RESULTS FOR L= 258.0 ,Q= 400.0 ,JD= 18.00 ,ID= 17.00

L= 258.0	, P= 700.0 ,RO= 3.27 ,BU= 14.40
L= 248.0	, P= 820.8 ,RO= 3.75 ,BU= 13.65
L= 238.0	, P= 928.0 ,RO= 4.15 ,BU= 13.00
L= 228.0	, P= 1025.8 ,RO= 4.53 ,BU= 12.42
L= 218.0	, P= 1116.3 ,RO= 4.86 ,BU= 11.89
L= 208.0	, P= 1201.0 ,RO= 5.17 ,BU= 11.40
L= 198.0	, P= 1281.1 ,RO= 5.46 ,BU= 10.95
L= 188.0	, P= 1357.2 ,RO= 5.74 ,BU= 10.52
L= 178.0	, P= 1429.9 ,RO= 5.00 ,BU= 10.11
L= 168.0	, P= 1499.7 ,RO= 6.24 ,BU= 9.72
L= 158.0	, P= 1566.8 ,RO= 6.48 ,BU= 9.35
L= 148.0	, P= 1631.7 ,RO= 5.70 ,BU= 8.99
L= 138.0	, P= 1694.4 ,RO= 5.92 ,BU= 8.64
L= 128.0	, P= 1755.3 ,RO= 7.14 ,BU= 8.31
L= 118.0	, P= 1814.5 ,RO= 7.34 ,BU= 7.99
L= 108.0	, P= 1872.1 ,RO= 7.54 ,BU= 7.68
L= 98.0	, P= 1928.2 ,RO= 7.73 ,BU= 7.37
L= 88.0	, P= 1983.0 ,RO= 7.92 ,BU= 7.07
L= 78.0	, P= 2036.6 ,RO= 8.10 ,BU= 6.78
L= 68.0	, P= 2088.9 ,RO= 8.28 ,BU= 6.50
L= 58.0	, P= 2140.2 ,RO= 8.45 ,BU= 6.23
L= 48.0	, P= 2190.5 ,RO= 8.63 ,BU= 5.96
L= 38.0	, P= 2240.2 ,RO= 8.80 ,BU= 5.69
L= 28.0	, P= 2288.2 ,RO= 8.95 ,BU= 5.43
L= 18.0	, P= 2336.2 ,RO= 9.12 ,BU= 5.18
L= 8.0	, P= 2382.9 ,RO= 9.28 ,BU= 4.93
L= 0.0	, P= 2419.8 ,RO= 9.41 ,BU= 4.73

AVERAGE PRESSURE IN SECTION WOULD BE 1717.9
 AVERAGE DENSITY IN SECTION WOULD BE 7.01
 AVERAGE BUOYANCY IN SECTION WOULD BE 8.52

RESULTS FOR L= 258.0 ,Q= 200.0 ,JD= 18.00 ,ID= 17.00

L= 258.0	, P= 700.0 ,RD=	3.27 ,BU=	14.40
L= 248.0	, P= 731.8 ,RD=	3.40 ,BU=	14.20
L= 238.0	, P= 762.4 ,RD=	3.52 ,BU=	14.01
L= 228.0	, P= 792.1 ,RD=	3.64 ,BU=	13.83
L= 218.0	, P= 820.8 ,RD=	3.75 ,BU=	13.65
L= 208.0	, P= 848.6 ,RD=	3.86 ,BU=	13.48
L= 198.0	, P= 875.8 ,RD=	3.96 ,BU=	13.31
L= 188.0	, P= 902.2 ,RD=	4.06 ,BU=	13.16
L= 178.0	, P= 928.0 ,RD=	4.16 ,BU=	13.00
L= 168.0	, P= 953.2 ,RD=	4.26 ,BU=	12.85
L= 158.0	, P= 977.8 ,RD=	4.35 ,BU=	12.70
L= 148.0	, P= 1001.9 ,RD=	4.44 ,BU=	12.56
L= 138.0	, P= 1025.8 ,RD=	4.53 ,BU=	12.42
L= 128.0	, P= 1049.0 ,RD=	4.62 ,BU=	12.28
L= 118.0	, P= 1071.8 ,RD=	4.70 ,BU=	12.15
L= 108.0	, P= 1094.2 ,RD=	4.78 ,BU=	12.02
L= 98.0	, P= 1116.3 ,RD=	4.86 ,BU=	11.89
L= 88.0	, P= 1138.0 ,RD=	4.94 ,BU=	11.77
L= 78.0	, P= 1159.3 ,RD=	5.02 ,BU=	11.64
L= 68.0	, P= 1180.3 ,RD=	5.10 ,BU=	11.52
L= 58.0	, P= 1201.0 ,RD=	5.17 ,BU=	11.40
L= 48.0	, P= 1221.4 ,RD=	5.25 ,BU=	11.29
L= 38.0	, P= 1241.6 ,RD=	5.32 ,BU=	11.17
L= 28.0	, P= 1261.5 ,RD=	5.39 ,BU=	11.06
L= 18.0	, P= 1281.1 ,RD=	5.46 ,BU=	10.95
L= 8.0	, P= 1300.4 ,RD=	5.53 ,BU=	10.84
L= 0.0	, P= 1315.8 ,RD=	5.59 ,BU=	10.75

AVERAGE PRESSURE IN SECTION WOULD BE 1039.2
 AVERAGE DENSITY IN SECTION WOULD BE 4.58
 AVERAGE BUOYANCY IN SECTION WOULD BE 12.34

RESULTS FOR L= 258.0 ,Q= 300.0 ,OD= 18.00 ,ID= 17.00

L= 258.0	, P= 700.0 ,RO=	3.27 ,BU=	14.40
L= 248.0	, P= 769.9 ,RO=	3.55 ,BU=	13.96
L= 238.0	, P= 834.8 ,RO=	3.80 ,BU=	13.56
L= 228.0	, P= 895.6 ,RO=	4.04 ,BU=	13.19
L= 218.0	, P= 953.2 ,RO=	4.26 ,BU=	12.85
L= 208.0	, P= 1008.1 ,RO=	4.46 ,BU=	12.52
L= 198.0	, P= 1060.5 ,RO=	4.66 ,BU=	12.22
L= 188.0	, P= 1110.8 ,RO=	4.84 ,BU=	11.97
L= 178.0	, P= 1159.3 ,RO=	5.02 ,BU=	11.64
L= 168.0	, P= 1206.2 ,RO=	5.19 ,BU=	11.37
L= 158.0	, P= 1251.6 ,RO=	5.36 ,BU=	11.11
L= 148.0	, P= 1295.6 ,RO=	5.52 ,BU=	10.86
L= 138.0	, P= 1338.5 ,RO=	5.67 ,BU=	10.62
L= 128.0	, P= 1380.2 ,RO=	5.82 ,BU=	10.39
L= 118.0	, P= 1421.0 ,RO=	5.96 ,BU=	10.16
L= 108.0	, P= 1460.8 ,RO=	6.10 ,BU=	9.94
L= 98.0	, P= 1499.7 ,RO=	6.24 ,BU=	9.72
L= 88.0	, P= 1537.7 ,RO=	6.38 ,BU=	9.51
L= 78.0	, P= 1575.0 ,RO=	6.51 ,BU=	9.30
L= 68.0	, P= 1611.6 ,RO=	6.63 ,BU=	9.10
L= 58.0	, P= 1647.5 ,RO=	6.76 ,BU=	8.90
L= 48.0	, P= 1682.8 ,RO=	6.88 ,BU=	8.71
L= 38.0	, P= 1717.5 ,RO=	7.00 ,BU=	8.52
L= 28.0	, P= 1751.6 ,RO=	7.12 ,BU=	8.33
L= 18.0	, P= 1785.1 ,RO=	7.24 ,BU=	8.15
L= 8.0	, P= 1818.1 ,RO=	7.35 ,BU=	7.97
L= 0.0	, P= 1844.2 ,RO=	7.44 ,BU=	7.83

AVERAGE PRESSURE IN SECTION WOULD BE 1357.9
 AVERAGE DENSITY IN SECTION WOULD BE 5.74
 AVERAGE BUOYANCY IN SECTION WOULD BE 10.51

RESULTS FOR L= 258.0 ,Q= 400.0 ,OD= 24.00 ,ID= 22.75

L= 258.0	, P= 700.0 ,RO= 3.27 ,BU= 35.65
L= 248.0	, P= 730.7 ,RO= 3.39 ,BU= 35.31
L= 238.0	, P= 760.4 ,RO= 3.51 ,BU= 34.97
L= 228.0	, P= 789.0 ,RO= 3.62 ,BU= 34.65
L= 218.0	, P= 816.9 ,RO= 3.73 ,BU= 34.35
L= 208.0	, P= 843.9 ,RO= 3.84 ,BU= 34.05
L= 198.0	, P= 870.2 ,RO= 3.94 ,BU= 33.76
L= 188.0	, P= 895.9 ,RO= 4.04 ,BU= 33.49
L= 178.0	, P= 920.9 ,RO= 4.13 ,BU= 33.22
L= 168.0	, P= 945.4 ,RO= 4.23 ,BU= 32.95
L= 158.0	, P= 969.4 ,RO= 4.32 ,BU= 32.70
L= 148.0	, P= 992.8 ,RO= 4.41 ,BU= 32.45
L= 138.0	, P= 1015.8 ,RO= 4.49 ,BU= 32.20
L= 128.0	, P= 1038.7 ,RO= 4.58 ,BU= 31.97
L= 118.0	, P= 1060.9 ,RO= 4.66 ,BU= 31.73
L= 108.0	, P= 1082.7 ,RO= 4.74 ,BU= 31.50
L= 98.0	, P= 1104.2 ,RO= 4.82 ,BU= 31.28
L= 88.0	, P= 1125.3 ,RO= 4.90 ,BU= 31.06
L= 78.0	, P= 1146.1 ,RO= 4.97 ,BU= 30.85
L= 68.0	, P= 1166.6 ,RO= 5.05 ,BU= 30.63
L= 58.0	, P= 1186.8 ,RO= 5.12 ,BU= 30.43
L= 48.0	, P= 1206.7 ,RO= 5.19 ,BU= 30.22
L= 38.0	, P= 1226.3 ,RO= 5.27 ,BU= 30.02
L= 28.0	, P= 1245.7 ,RO= 5.34 ,BU= 29.82
L= 18.0	, P= 1264.9 ,RO= 5.41 ,BU= 29.63
L= 8.0	, P= 1283.8 ,RO= 5.47 ,BU= 29.43
L= 0.0	, P= 1298.7 ,RO= 5.53 ,BU= 29.28

AVERAGE PRESSURE IN SECTION WOULD BE 1029.3
 AVERAGE DENSITY IN SECTION WOULD BE 4.54
 AVERAGE BUOYANCY IN SECTION WOULD BE 32.06

RESULTS FOR L= 258.0 ,Q= 200.0 ,DD= 24.00 ,ID= 22.75

L= 258.0	, P= 700.0 ,RO= 3.27 ,BU= 35.65
L= 248.0	, P= 713.7 ,RO= 3.33 ,BU= 35.50
L= 238.0	, P= 727.2 ,RO= 3.38 ,BU= 35.34
L= 228.0	, P= 740.5 ,RO= 3.43 ,BU= 35.20
L= 218.0	, P= 753.5 ,RO= 3.48 ,BU= 35.05
L= 208.0	, P= 766.4 ,RO= 3.54 ,BU= 34.91
L= 198.0	, P= 779.1 ,RO= 3.59 ,BU= 34.76
L= 188.0	, P= 791.7 ,RO= 3.63 ,BU= 34.63
L= 178.0	, P= 804.0 ,RO= 3.68 ,BU= 34.49
L= 168.0	, P= 816.2 ,RO= 3.73 ,BU= 34.35
L= 158.0	, P= 828.3 ,RO= 3.78 ,BU= 34.22
L= 148.0	, P= 840.2 ,RO= 3.82 ,BU= 34.09
L= 138.0	, P= 851.9 ,RO= 3.87 ,BU= 33.96
L= 128.0	, P= 863.5 ,RO= 3.91 ,BU= 33.84
L= 118.0	, P= 875.0 ,RO= 3.96 ,BU= 33.71
L= 108.0	, P= 886.4 ,RO= 4.00 ,BU= 33.59
L= 98.0	, P= 897.6 ,RO= 4.04 ,BU= 33.47
L= 88.0	, P= 908.8 ,RO= 4.09 ,BU= 33.35
L= 78.0	, P= 919.8 ,RO= 4.13 ,BU= 33.23
L= 68.0	, P= 930.7 ,RO= 4.17 ,BU= 33.11
L= 58.0	, P= 941.4 ,RO= 4.21 ,BU= 33.00
L= 48.0	, P= 952.1 ,RO= 4.25 ,BU= 32.88
L= 38.0	, P= 962.7 ,RO= 4.29 ,BU= 32.77
L= 28.0	, P= 973.2 ,RO= 4.33 ,BU= 32.66
L= 18.0	, P= 983.6 ,RO= 4.37 ,BU= 32.55
L= 8.0	, P= 993.9 ,RO= 4.41 ,BU= 32.44
L= 0.0	, P= 1002.1 ,RO= 4.44 ,BU= 32.35

AVERAGE PRESSURE IN SECTION WOULD BE 860.0
 AVERAGE DENSITY IN SECTION WOULD BE 3.90
 AVERAGE BUOYANCY IN SECTION WOULD BE 33.88

RESULTS FOR L= 258.0 ,Q= 300.0 ,OD= 24.00 ,ID= 22.75

L= 258.0	, P= 700.0 ,RO= 3.27 ,BU= 35.65
L= 248.0	, P= 717.4 ,RO= 3.34 ,BU= 35.45
L= 238.0	, P= 734.5 ,RO= 3.41 ,BU= 35.26
L= 228.0	, P= 751.2 ,RO= 3.48 ,BU= 35.08
L= 218.0	, P= 767.6 ,RO= 3.54 ,BU= 34.89
L= 208.0	, P= 783.7 ,RO= 3.60 ,BU= 34.71
L= 198.0	, P= 799.6 ,RO= 3.67 ,BU= 34.54
L= 188.0	, P= 815.1 ,RO= 3.73 ,BU= 34.37
L= 178.0	, P= 830.5 ,RO= 3.79 ,BU= 34.20
L= 168.0	, P= 845.6 ,RO= 3.84 ,BU= 34.03
L= 158.0	, P= 860.4 ,RO= 3.90 ,BU= 33.87
L= 148.0	, P= 875.1 ,RO= 3.96 ,BU= 33.71
L= 138.0	, P= 889.5 ,RO= 4.01 ,BU= 33.55
L= 128.0	, P= 903.8 ,RO= 4.07 ,BU= 33.40
L= 118.0	, P= 917.8 ,RO= 4.12 ,BU= 33.25
L= 108.0	, P= 931.7 ,RO= 4.17 ,BU= 33.10
L= 98.0	, P= 945.4 ,RO= 4.23 ,BU= 32.95
L= 88.0	, P= 958.9 ,RO= 4.28 ,BU= 32.81
L= 78.0	, P= 972.3 ,RO= 4.33 ,BU= 32.67
L= 68.0	, P= 985.5 ,RO= 4.38 ,BU= 32.53
L= 58.0	, P= 998.6 ,RO= 4.43 ,BU= 32.39
L= 48.0	, P= 1011.8 ,RO= 4.48 ,BU= 32.25
L= 38.0	, P= 1024.6 ,RO= 4.52 ,BU= 32.11
L= 28.0	, P= 1037.3 ,RO= 4.57 ,BU= 31.98
L= 18.0	, P= 1049.8 ,RO= 4.62 ,BU= 31.85
L= 8.0	, P= 1062.2 ,RO= 4.66 ,BU= 31.72
L= 0.0	, P= 1072.1 ,RO= 4.70 ,BU= 31.61

AVERAGE PRESSURE IN SECTION WOULD BE 899.1
 AVERAGE DENSITY IN SECTION WOULD BE 4.05
 AVERAGE BUOYANCY IN SECTION WOULD BE 33.45

APPENDIX III

LETTERS AND INTERVIEW
RECORDS CONCERNING CURRENTS
AND WAVES IN MEDITERRANEAN SEA

NATIONAL INSTITUTE OF OCEANOGRAPHY

TELEPHONE: WORMLEY 2122
TELEGRAPHIC ADDRESS: OCEANS, WORMLEY, SURREY
RLY. STATION: WITLEY

WORMLEY, GODALMING,
SURREY.

OUR REF. JCS/PES

YOUR REF.

24th September 1969

Professor G.H. Savage,
Lloyd Noble Petroleum Engineering Laboratories,
Stanford University,
Stanford,
California 94305.
U.S.A.

Dear Professor Savage,

I am afraid that my experience of currents in the Mediterranean is very limited, too limited to be of much use in deciding on the shape of a maximum velocity profile. Professor Allmendinger telephoned me this morning but we were not able to arrange a meeting - I am off to a conference in Dublin and then at sea after that until mid-October, so I agreed to write directly to you.

Rocky Miller's suggesting my name in relation to Mediterranean currents is probably based on some co-operative work that we did in the N.W. Mediterranean in February and March this year. We made some current measurements from the "Discovery", using both moored current meters and neutrally buoyant floats, in a small area (approx. 40 mls square) near 42°N, 5°E. The duration of individual moorings was 1 to 2 weeks, with 3 to 5 current meters per mooring. About 70 per cent of records are usable. Floats were tracked for periods of about a week each. In all, 10 moorings and 20 floats were laid. Evidently these do not provide anything more than a very limited view of currents in the Mediterranean. Speeds were typically of the order of 20 cm/sec at 100m, and 10 cm/sec at 300 - 1500m, the maximum speeds observed being less than 3 times those values. The measurements were made in a region where new deep water was being formed. Currents were quite variable in the horizontal, with a typical radius of curvature of float trajectories of about 20 km. I have no idea how typical these currents may be, of conditions in the Mediterranean generally.

Yours sincerely,



J.C. Swallow

REPORT OF DISCUSSION WITH PROFESSOR LACOMBE

(October, 1969)

Reference is made to charts provided by Professor LaCombe and to xeroxed chart on which areas A, B and C are designated.

1. Open Ocean - 50 miles off shore

a. Below 200 meters - Current velocity small - 10 cm/sec max and rotating in a clockwise direction with a period of about 17 hours. Radius of rotation decreases with increased depth (see enclosed charts and articles)

b. Near Surface - Current may have higher velocities due to wind - may reach 1.5 knots in shallow layer down to 50-60 meters. In period May to December, there is a distinctive thermocline with higher velocities above and lower velocities below. Above thermocline, current velocities have higher velocities reaching 1.5 knots. Below thermocline to bottom, velocities are about 10 cm/sec and lower. Direction of upper layer current related to wind direction.

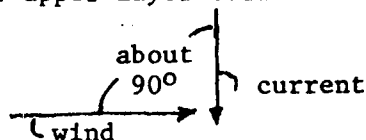

c. Sea States - Practically no swell. Only wind-generated waves. Must refer to meteorological data. Waves of 6 to 7 meters have been generated by storms. The worst area is the Gulf of Leone.

2. Near Shore (Refer to xerox chart)

a. Area A

(Phillpeville Coast)

(1) Near Surface - Average current velocity of about 1 knot down to about 100 meters. Direction is toward the east. Higher velocities may be obtained near surface due to winds - a max of about 2.5 knots in a strong wind.

(2) Below 100 meters - Current velocity less than 1 knot, decreasing to less than 10 cm/sec at greater depths.

(3) Sea States - May have high winds from the west in period of November to April. Higher Sea States (waves of 5-6 meters) can be expected.

LACOMBE (CONTINUED)

b. Area B (*French Coast*)

- (1) Near Surface - Current velocities of 1 knot down to 100 meters depth. Direction of current vector is generally to the west. With winds from the east, wind-driven currents may attain velocities of about 2 knots with direction to the west.
- (2) Below 100 meters - Current velocities of 10 cm/sec or less with direction to the west.
- (3) Sea States - Area not far from Gulf of Leone, an area notorious for severe storms. Storm waves may approach 7+ meters in height.

(*Barcelona Coast*)

c. Area C - Professor LaCombe has little information on this area.

- (1) Near Surface - May have rather high winds from the north-east, causing drift current to add to mean current giving a higher, near surface velocities - perhaps approaching 1.5 knots. Direction generally south-west.
- (2) Below 100 meters - Current velocity probably about 10 cm/sec or less.
- (3) Sea States - LaCombe had no specific information.

APPENDIX IV

APPENDIX IV

INSTALLATION METHODOLOGY

It is visualized that the pipeline will be installed using essentially the same methods now used to install marine pipelines; welding the pipe sections in a continuous string and paying them out off the end of the pipe-laying barge. The primary change is that the pipeline will be buoyant and float on the surface. A structural stinger to support the pipe weight will not be necessary. In fact, the pipeline will have to be pulled under the water surface to its final location.

The major steps envisioned in the installation method upon which the cost estimates are based are as follows:

- 1) The buoyant towers will be installed in a straight line well in advance of the pipeline using essentially the same method outlined by Savage and Hersey (20) for the Sea Spider trimoored buoy. Bottom mounted acoustic navigation devices and optical surveying from one intermediate station to another (only 900 ft) can assure accurate emplacement of the towers. Once they are installed, acoustic location by vessel and optical surveying can determine the actual distance between any two towers by a few feet (20).

2) The pipe-laying barge will then proceed to pay out the pipe from the last bottom mounted station. As each 900 foot length is completed, the intermediate cables will be payed out from the auxiliary vessel, anchor first, and attached with the intermediate buoy to the pipe. At this point, the empty pipe will be much too buoyant and must be ballasted with steel weight collars spaced at appropriate intervals so that the maximum buoyancy force per foot of pipe is only the specified 5 lbs/ft for the 24 inch line for example. This ballasting will prevent the pipe from being overstressed as it is pulled down by the intermediate anchors when they are released by the auxiliary vessels. Meanwhile the laying barge must have sufficient thrust from its propellers to both maintain itself on a straight line and provide sufficient pipe tension to hold the pipeline as taut as it must be when the anchors are set. Only the 900 feet of pipe section on the surface will be subjected to surface currents and the auxiliary vessel will be helping to hold the current induced side forces on the pipe. The laying vessel will be holding tensions of a magnitude equivalent to those calculated as maximum forces on the towers in Table I, Chapter 4. Figure IV-1 shows plan and side views of the pipeline and installation

vessels at this stage of installation.

- 3) When a tower site is reached, a different procedure is necessary. The 900 foot segment is weighted to be slightly negatively buoyant. It is held up near the surface by the secondary tower buoy that is attached by the auxiliary vessel. The pipe is then lowered to depth and attached by divers to the tower. The secondary buoy is then pulled down into place by the auxiliary vessel using pulleys, and secured by divers who also cut off the extra cable. See Figure IV-2.
- 4) The procedure then goes on until the next tower is reached.

This brief explanation of the installation procedure assumes a high degree of coordination and seamanship on the part of all vessels and crews. Naturally, there will be a learning period and it is probable there will be many problems before a standard procedure is worked out and a good laying speed achieved. Diving teams of highly qualified divers will be necessary to the entire operation.

The trimming procedure has already been referred to. Installed and empty, the line will be much too heavy to accept its expected half-capacity, initial gas throughput. It will be necessary to lighten the line by stages, building up the throughput at each stage. This will be accomplished by removing one of the weight collars every

so many feet for the entire pipeline length and then building the gas pressure to offset that weight. The weight collars will be removed by divers working from a lock-in-lock-out submarine who will use cutting torches to cut bolts holding the collars to the pipe. Several of these trimming steps may be necessary to bring the pipe up to the desired throughput level without overstressing it due to excess buoyancy at any step. The collars will be lost forever, dropping to the bottom unless it is found feasible to salvage them by pulling them to a surface vessel when they are cut loose. The weight of the collars and the number required per 100 feet of pipeline to carry out the trimming procedure to ultimate capacity will be a study in itself and the details are not worked out here. The cost of the collars and the trimming is considered part of the 10% contingencies estimate in the investment.

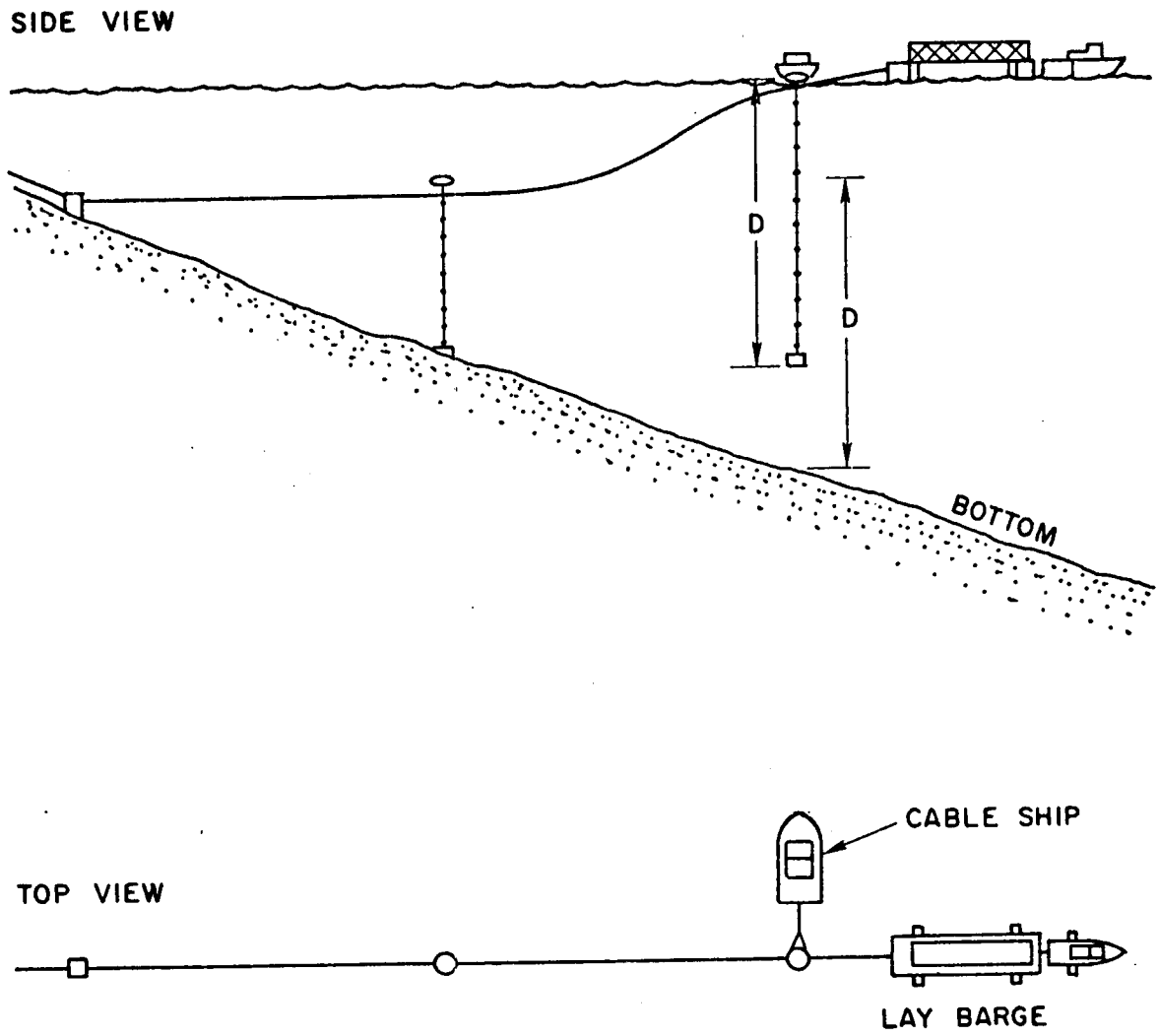
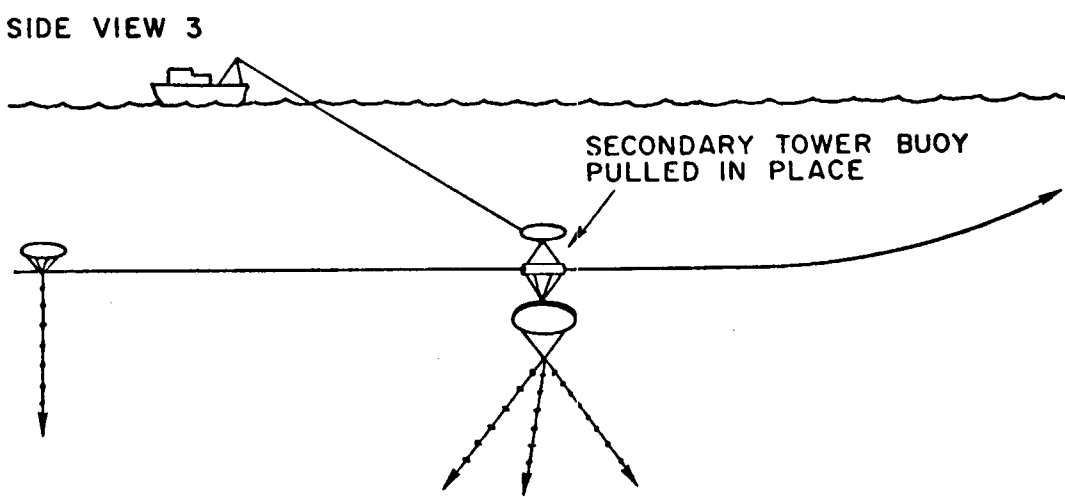
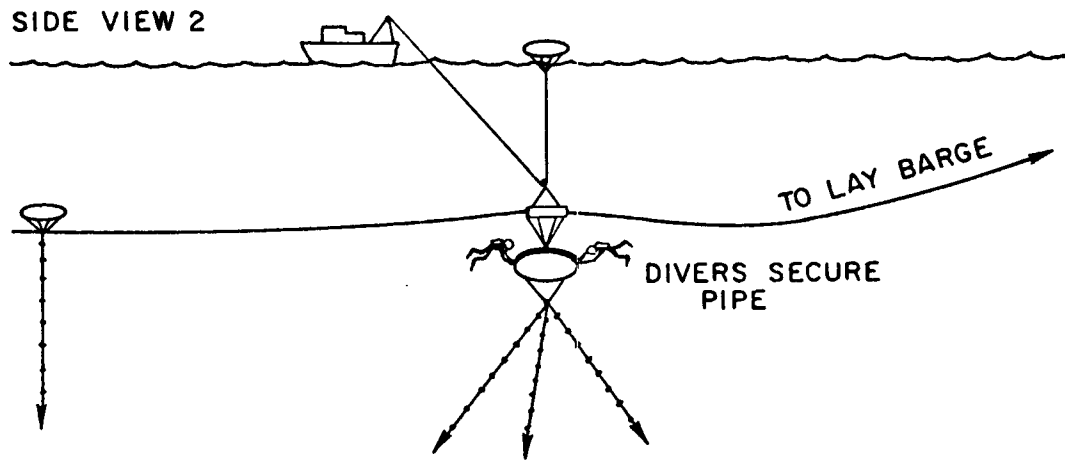
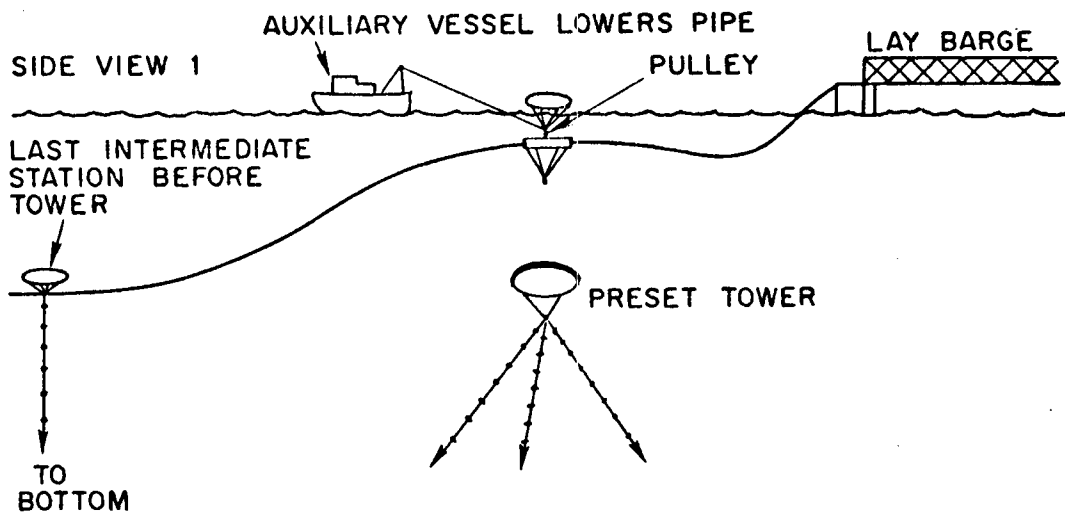

Figure IV-1: Pulling Pipe Down with Intermediate Cables

Figure IV-2: Making A Tower Connection



APPENDIX V

APPENDIX V

SAFETY DEVICES

As shown in Figure 4-3, there will be safety valves and explosive flanges provided on the pipeline on each side of every tower. The purpose of these safety devices is to assure that a break in the pipeline can flood only one ruptured sublength in which the break occurs. The broken pipe will cause a rapid pressure change in the pipe in the vicinity of the break. The pressure change will activate the safety valves near the towers at each end of the section (see Figure 4-3) and also signal to the line operator which valves have been set. These valves are visualized as being bag valves which are inflated into the pipeline by high pressure air cylinders for each valve and therefore quick reacting. With the pressure shut off, the ruptured sublength will probably quickly flood and begin to sink. As it pulls down the two towers, pressure activated switches set for 600 foot depths, will trigger the explosive bolt flanges, the pipe sublength will separate at these two ends and drop to the bottom. The bending stresses already developed at the flanges by the flooded pipe weight will assist the pipe separation when the flanges are triggered. If the pipeline only partially floods, its

intermediate buoys may hold it up, the flanges not fire and the pipe sublength may be salvaged. These flanges are only a final safety precaution.

It is also visualized that there will be a pressure activated alarm switch at every cable station on the pipeline that will go off if the external pressure varies by more than 50 lbs. In the event that several intermediate cables fail and the pipeline rises to the surface or buoys fail and the pipeline sags, the operator will be warned and can take remedial action.

APPENDIX VI

COMPUTER PROGRAM TO COMPUTE
ESTIMATED RETURN ON INVESTMENT
FOR VARIOUS GAS PRICES
AND EXPECTED PIPELINE LIFE

```

39      50 FORMAT('1',50X,'RATE OF INTEREST : ',F4.1,' PER CENT.',
1         / ,50X,'-----'),
2         / ,50X,'-----')
40      DO 2 H=1,HMAX
41      PRINT 51,LIFE(H)
42      51 FORMAT('0',40X,'EXPECTED LIFE OF PIPELINE : ',I2,' YEARS.',
1         / ,40X,'-----')
43      DO 2 B=1,BMAX
44      PRINT 52,Q(B)
45      52 FORMAT('0',20X,'FLOW RATE : ',F6.1,' MMSCF/D.')
46      DO 6 C=1,CMAX
47      PRINT 53,OD(C)
48      53 FORMAT('0','LINE DIAMETER : ',F5.2,' IN.')
49      I=0
50      IF (IDD(B,C,1).EQ.0..OR.IDD(B,C,2).EQ.0.) GO TO 6
51      I=1
52      DO 4 BP=1,BPMAX
53      PRINT 54,GASBP(BP)
54      54 FORMAT('0',30X,'GAS BOUGHT AT ',F4.2,' DOLLARS/MSCF.')
55      CALL PIPOUT(MARR(F),N1(B),LIFE(H),B,H,ALPHA)
56      GPS1 = GASBP(BP)
57      GPS2 = GASBP(BP)
58      20 GP = GPS2
59      A = 1
60      CALL POWOUT(MARR(F),N1(B),LIFE(H),M1,M2,GPS1)
61      A = 2
62      CALL PCWOUT(MARR(F),N1(B),LIFE(H),M1,M2,GPS2)
63      CALL GASPF(MARR(F),N1(B),LIFE(H),M1,M2,Q(B),GAMMA)
64      GPEUR1 = (ALPHA+BETA(1)+BETA(2))/GAMMA + GPS1
65      GPS2 = GPS1 + (GPEUR1-GPS1)*258./498.
66      IF (GPS2.GT.(GP+.01)) GO TO 20
67      PRINT 55,GPS2
68      55 FORMAT(30X,'AND CHARGED ',F4.2,' DOLLARS/MSCF',
1         / ,30X,' AT STATION 2.')
69      DO 5 SP=1,SPMAX
70      IF (SP.GT.1) GO TO 19
71      PRINT 56
72      56 FORMAT('0',30X,'SELLING PRICE',7X,'RATE OF RETURN',
1         / ,30X,'(DOLLARS/MSCF)',7X,'ON INVESTMENT')
73      19 IF (GPEUR1.LE.GASSP(SP)) GO TO 22
74      PRINT 21,GASSP(SP)
75      21 FORMAT('0','THIS PROPOSAL NOT FEASIBLE FOR GAS SELLING ',
1         / ,30X,' PRICE AT ',F4.2,' $/MSCF IN FRANCE.')
76      GO TO 5
77      22 FLAG = 1
78      DUMR = MARR(F)
79      23 ROR = DUMR+.10
80      24 CALL PIPOUT(ROR ,N1(B),LIFE(H),B,H,ALPHA)
81      A = 1
82      CALL POWOUT(ROR,N1(B),LIFE(H),M1,M2,GPS1)
83      A = 2
84      CALL PCWOUT(ROR,N1(B),LIFE(H),M1,M2,GPS2)
85      CALL GASPF(ROR ,N1(B),LIFE(H),M1,M2,Q(B),GAMMA)
86      GPEUR2 = GPS1 + (ALPHA+BETA(1)+BETA(2))/GAMMA
87      GO TO (25,28,31),FLAG
88      25 IF (GPEUR2-GASSP(SP)) 26,32,27
89      26 DUMR = ROR
90      GO TO 23
91      27 FLAG = 2
92      ROR = DUMR+.02

```

```

93      GO TO 24
94      28 IF (GPEUR2-GASSP(SP)) 29,32,30
95      29 DUMR = ROR
96      GO TO 27
97      30 FLAG = 3
98      ROR = DUMR + .005
99      GO TO 24
100     31 IF (GPEUR2-GASSP(SP)) 29,32,32
101     32 PRINT 57,GASSP(SP),ROR*100
EXTENSION*  IO-C
102     57 FORMAT('0',35X,F4.2,15X,F4.1,' PER CENT.')
```

5 CONTINUE
4 CONTINUE
IF (I.EQ.1) GO TO 2
6 CONTINUE
2 CONTINUE
3 CONTINUE
STOP
END

C
C
C
C

```

111      SUBROUTINE INPUT
      C
      C
      C
112      DIMENSION BETA(2),N1(5),LIFE(5)
113      COMMON /COM1/ A,AMAX,B,BMAX,C,CMAX,D,L,Q,OD,ID,ODD,IDD,POW
114      COMMON /COM2/ STEPL,RO1,RO2,G,PB,TB,K,P2,PC,TC,TF,FE,FF
115      COMMON /COM3/ STEPLO,RO1O,RO2O,GO,PBO,TBO,KO,P2O,PCO,TCO,TFO,FEJ,
      1      FFO
116      COMMON /COM4/ IDPIPE,LX,PX,ROX,BUX,DISTMM,PAV,ROAV,BOAV,THP,V,UHP
117      COMMON /COMA/ M1,M2,FMAX,HMAX,MARR,LIFE,BPMAX,SPMAX,
      1      GASBP,GASSP,N1,PIPCAP,PIPMAI
118      INTEGER A,AMAX,B,BMAX,C,CMAX,D,DIST,DISTM,DISTMM,FLO
119      INTEGER F,FMAX,FLAG,H,HMAX,BP,BPMAX,SP,SPMAX
120      REAL IDPIPE
121      REAL L(3),Q(5),OD(10),ID(10,10),LX(100),PX(100),ROX(100),BUX(100),
      1      ODD(5,10),IDD(5,10,3),POW(5,10,3,5)
122      REAL GASBP(5),GASSP(5),MARR(5),PIPCAP(5),PIPMAI(5,5)
123      READ 11 , AMAX,BMAX, CMAX
124      11 FORMAT(3I2)
      C AMAX IS THE NUMBER OF PIPELINE SECTIONS CONSIDERED
      C BMAX IS THE NUMBER OF FINAL FLOW RATES CONSIDERED
      C CMAX IS THE NUMBER OF OUTSIDE DIAMETERS CONSIDERED
125      READ 12 , STEPL, RO1, RO2, G, PB, TB, K, P2, PC, TC, TF, FE, FF
126      12 FORMAT(F80.2)
      C STEPL (10. MILES IF 0)
127      IF (STEPL.EQ.0) STEPL= STEPLO
      C DENSITY RO1 OF PIPE (490. LBS/CFT IF 0)
128      IF (RO1.EQ.0) RO1=RO1O
      C DENSITY RO2 OF SALTED WATER (0.64 LBS/CFT IF 0)
129      IF (RO2.EQ.0) RO2= RO2O
      C SPECIFIC GRAVITY OF NATURAL GAS (0.66 IF 0)
130      IF (G.EQ.0) G= GO
      C
131      IF (PB.EQ.0) PB= PBO
      C
132      IF (TB.EQ.0) TB= TBO
      C
133      IF (K.EQ.0) K= KO
      C
134      IF (P2.EQ.0) P2= P2O
      C
135      IF (PC.EQ.0) PC= PCO
      C
136      IF (TC.EQ.0) TC= TCO
      C
137      IF (TF.EQ.0) TF= TFO
      C
138      IF (FE.EQ.0) FE= FEO
      C
139      IF (FF.EQ.0) FF= FFO
140      DO 1 A = 1,AMAX
141      1 READ 12 ,L(A)
142      DO 2 B = 1,BMAX
143      2 READ 12 ,Q(B)
144      DO 3 C = 1,CMAX
145      READ 12 ,OD(C)
146      CALL IDSUB(OD(C),C,ID)
147      3 CONTINUE

```

```

148      RETURN
149      ENTRY INPUT1
150      READ 11,M1,M2
151      READ 11,FMAX,HMAX
152      DO 4 F=1,FMAX
153      4 READ 13,MARR(F)
154      13 FORMAT(10F5.3)
155      DO 5 H=1,HMAX
156      5 READ 11,LIFE(H)
157      READ 11,BPMAX,SPMAX
158      DO 6 BP=1,BPMAX
159      6 READ 12,GASBP(BP)
160      DO 7 SP=1,SPMAX
161      7 READ 12,GASSP(SP)
162      DO 8 B=1,BMAX
163      READ 11,N1(B)
164      READ 14,PIPCAP(B)
165      DO 8 H=1,HMAX
166      8 READ 14,PIPMAI(B,H)
167      14 FORMAT(8F10.0)
168      RETURN
169      END

```

```

C
C
C
C

```

```

170      SUBROUTINE COMP (VL,VQ,VOD, ID,C,*,*)
      C
      C
      C
171      COMMON /COM2/ STEPL,RO1,RO2,G,PB,TB,K,P2,PC,TC,TF,FE,FF
172      COMMON /COM4/ IDPIPE,LX,PX,ROX,BUX,DISTMM,PAV,ROAV,BOAV,THP,V,U4P
173      INTEGER A,AMAX,8,BMAX,C,CMAX,D,DIST,DISTM,DISTMM,FLO
174      REAL L(3),Q(5),OD(10),ID(10,10),LX(100),PX(100),ROX(100),BUX(100),
1      ODD(5,10),IDD(5,10,3),POW(5,10,3,5)
175      REAL IDPIPE,K
176      PAVSUB(PA,PB) = 2./3.*( PA+PB - PA*PB/(PA+PB) )
177      BUSUB(VOD,VID,VRO,VRO1,VRO2) =
1      ( (VRO2-VRO1)*VOD*VOD + (VRO1-VRO)*VID*VID ) * 3.14159/576.
178      DISTM = VL/STEPL + 1
179      DISTMM = DISTM + 1
180      LX(DISTMM) = VL
181      DO 1 I = 1,10
182      IDPIPE = ID(C,I)
183      CALL FLOTYP(VQ,IDPIPE,G,PB,TB,K,FLO,FRN)
184      CALL PFLO(VL,VQ,IDPIPE,FRN,FLO,P,&5)
185      PX(DISTMM) = P
186      ROX(DISTMM) = ROSUB(PX(DISTMM))
187      BUX(DISTMM) = BUSUB(VOD,IDPIPE,ROX(DISTMM),RO1,RO2)
188      IF (BUX(DISTMM).LT.0.) GO TO 2
189      1 CONTINUE
190      2 IF (I.GT.1) GO TO 3
191      IDPIPE = ID(C,1)
192      PRINT 21,VL,VQ,VOD
193      21 FORMAT('0','WARNING FROM COMPUT: FOR L= ',F6.1,' ,Q= ',F6.1,
1      ' AND OD= ',F4.1, / ,' THERE IS NO ID WE CONSIDER',
2      ' LARGE ENOUGH TO MAKE THE LINE BUOYANT.',
3      / ,' PROGRAM WAS SENT TO NEXT COMPUTATION IN MAIN.')
```

```

194      RETURN 1
195      3 I = I-1
196      IDPIPE = ID(C,I)
197      GO TO 7
198      ENTRY COMP1 (VL,VQ,VOD)
199      CALL FLOTYP(VQ,IDPIPE,G,PB,TB,K,FLO,FRN)
200      7 CONTINUE
201      DISTMM = DISTM + 1
202      LX(DISTMM) = VL
203      CALL PFLO(LX(DISTMM),VQ,IDPIPE,FRN,FLO,P,&5)
C A NEUTRALLY OR POSITIVELY BUOYANT PIPE HAS BEEN FOUND.
C IF P1/P2 > 2., GO TONEXT COMPUTATION IN MAIN9
204      IF (P.LE.1500.0) GO TO 8
205      PRINT 22,VL,VQ,VOD,IDPIPE,P
206      22 FORMAT('0','MESSAGE FROM COMPUT: FOR L= ',F5.1,' ,Q= ',F6.1,
1      ' ,OD= ',F5.2,' AND ID= ',F5.2, / ,' A BUOYANT LINE',
2      ' EXISTS, BUT P1/P2 IS GREATER THAN 2., WITH P2= ',
3      F6.1,' PROGRAM WAS SENT TO NEXT COMPUTATION IN MAIN.')
```

```

207      RETURN 1
208      8 PX(DISTMM) = P
209      ROX(DISTMM) = ROSUB(PX(DISTMM))
210      BUX(DISTMM) = BUSUB(VOD,IDPIPE,ROX(DISTMM),RO1,RO2)
C COMPUTATION OF P.D.B. PROFILES.
211      DO 4 DIST = 1,DISTM
212      LX(DIST) = (DIST-1)*STEPL
213      CALL PFLO(LX(DIST),VQ,IDPIPE,FRN,FLO,P,&5)
214      PX(DIST) = P
```

```
215      ROX(DIST) = ROSUB(PX(DIST))
216      BUX(DIST) = BUSUB(VOD, IDPIPE, ROX(DIST), RO1, RO2)
217      4 CONTINUE
218      PAV = PAVSUB(P2, PX(DISTMM))
219      ROAV = ROSUB(PAV)
220      BUAV = BUSUB(VOD, IDPIPE, ROAV, RO1, RO2)
221      CALL POWER(P, VQ, THP, N, JHP)
222      RETURN
223      5 RETURN 2
224      END
```

```
C
C
C
C
```



```

225      SUBROUTINE POWER(VP,VQ,THP,N,UHP)
      C
      C
      C
226      COMMON /COM2/ STEPL,R01,R02,G,PB,TB,K,P2,PC,TC,TF,FE,FF
227      REAL KP,KT
228      KP = .9
229      KT = 1.0
230      SCR = VP/P2
231      2 IF (SCR-1.5) 3,3,4
232      3 VHP = (SCR-1.0)*50.0
233      GO TO 5
234      4 VHP = (25.0 + (SCR-1.5)*37.5) * 1.20
235      5 FUHP = VHP*KP*KT
236      THP = FUHP*VQ
237      6 RETURN
238      END
      C
      C
      C
      C

```

```

239      SUBROUTINE FLOTYP(VQ,VID,VG,VPB,VTB,VK,FLJ,FRN)
      C
      C
      C
      C
240      INTEGER FLO
241      FRNSUB(VQ,VID,VG,VPB,VTB) = 59.7*VQ/VID*VG*VPB/VTB*1.E6
242      CRNSUB(VID,VK) = 20.912*VID/VK*ALOG10(3.7*VID/VK)
243      TRNSUB(VCRN) = .706*VCRN**1.04 + 53350.
244      FRN = FRNSUB(VQ,VID,VG,VPB,VTB)
245      CRN = CRNSUB(VID,VK)
246      TRN = TRNSUB(CRN)
247      IF (FRN.GT.TRN) GO TO 1
      C
      C PARTIALLY TURBULENT FLOW
      C
248      FLO = 1
249      RETURN
      C
      C FULLY TURBULENT FLOW
      C
250      1 FLO = 2
251      RETURN
252      END
      C
      C
      C
      C

```

```

253          SUBROUTINE PFLO(VL,VQ,VID,VFRN,FLO,P,*)
          C
          C
          C
254          COMMON /COM2/ STEPL,RO1,RO2,G,PB,TB,K,P2,PC,TC,TF,FE,FF
255          INTEGER A,AMAX,B,BMAX,C,CMAX,D,DIST,DISTM,DISTMM,FLO
256          REAL*8 ZZ
257          PSUB(VL,VQ,VF,VP) = SQRT(VP*VP + VL*VQ*VQ*VF)
258          PAVSUB(PA,PB) = 2./3.*( PA+PB - PA*PB/(PA+PB) )
259          PAV = P2
260          DO 5 I = 1,10
261          1 CALL ZSUB(PC,TC,TF,PAV,ZZ)
262          Z = ZZ
263          GO TO (2,3),FLO
264          2 CALL FTSUB(VFRN,FT,&8)
265          F =          Z*G/.6*TF/520.* ( PB/14.73*520.E6/TB/.775/ VID**2.5
          1          /FE/FT/FF)**2
266          GO TO 4
267          3 F =          Z*G/.6*TF/520.* ( PB/14.73*520.E6/TB/3.1 / VID**2.5
          1          /FE/ALOG10(3.7*VID/K) )**2
268          4 DUMP = PSUB(VL,VQ,F,P2)
269          MIN = PAV - 5.
270          MAX = PAV + 5.
271          PAV = PAVSUB(P2,DUMP)
272          IF ( (MIN.LT.PAV).AND.(PAV.LT.MAX) ) GO TO 7
273          5 CONTINUE
274          PRINT 13,VL,VQ,VID,VFLO
275          13 FORMAT('0','10 LOOPS MADE IN PFLO FOR VL= ',F5.1,' ,VQ= ',F5.1,
          1          ',ID= ',F4.1,' (FLO= ',I1,' )' )
276          7 P = DUMP
277          RETURN
278          8 RETURN 1
279          END
          C
          C
          C

```

```

280      FUNCTION ROSUB(VP)
      C
      C
      C
281      COMMON /COM2/ STEPL,R01,R02,G,PB,TB,K,P2,PC,TC,TF,FE,FF
282      REAL*8 ZZ
283      CALL ZSUB(PC,TC,TF,VP,ZZ)
284      Z = ZZ
285      RCSUB = VP*G*28.97/Z/10.732/TF
286      RETURN
287      END
      C
      C
      C
      C

```

```

288          SUBROUTINE FTSUB(VFRN,FT,*)
          C
          C
          C
289          FTFRN(X) = X*10.**((X+.60)/4. )
290          I = 1
291          J = 1
292          K = 1
293          FT = 0.
294          VFT = 0.
295          1 A = FTFRN(FT)
296          IF (A-VFRN) 2,11,3
297          2 I = I+1
298          IF (I.GT.4) GO TO 9
299          VFT = FT
300          FT = FT+10.0
301          GO TO 1
302          3 FT = VFT
303          4 A = FTFRN(FT)
304          IF (A-VFRN) 5,11,6
305          5 J = J+1
306          IF (J.GT.11) GO TO 9
307          VFT = FT
308          FT = FT + 1.0
309          GO TO 4
310          6 FT = VFT
311          7 A = FTFRN(FT)
312          IF (A-VFRN) 8,11,11
313          8 K = K+1
314          IF (K.GT.11) GO TO 9
315          FT = FT + .1
316          GO TO 7
317          9 PRINT 14,I,J,K
318          14 FORMAT('0','FTSUB IN ERROR: I= ',I1,' ,J= ',I2,' ,K= ',I2,
          1 ' ,PROGRAM WAS STOPPED.')
319          RETURN 1
320          11 CONTINUE
321          RETURN
322          END
          C
          C
          C
          C

```

```

323      SUBROUTINE ZSUB(VPC,VTC,VTF,VP,ZZ)
      C
      C
      C
      C
324      REAL*8 COEF(6,6)/
1         2.1433504,          0.33123524,          0.10572871,
2        -0.052184040,        0.019703980,        -0.0053095900,
3         0.083176184,        -0.13403614,        -0.050393654,
4         0.044312146,        -0.026383354,        0.0089178330,
5        -0.021467042,        0.066880961,          0.0050924798,
6        -0.019329465,        0.019262143,        -0.010894921,
7        -0.00087140318,      -0.027174261,        0.010551336,
8         0.0058972516,      -0.01153539,         0.009559389,
9         0.0042846293,        0.0088512291,      -0.0073181933,
1         0.0015366676,        0.0042910089,      -0.0060114017,
2        -0.0016595343,      -0.0021520929,        0.0026959963,
3        -0.0028326809,      -0.00081302526,        0.0031175170/,
4         ZZ,POLSUB
325      PR = VP/VPC
326      TR = VTF/VTC
327      IF ( (PR.LT..1.OR.14.9.LT.PR).OR.(TR.LT.1.05.OR.2.95.LT.TR) )
328      1 PRINT 15,PR,TR
15 FORMAT('0',' THE RANGE FOR PR VALUES IS .1 TO 14.9 AND PR= ',
1 F5.2, ' THE RANGE FOR TR VALUES IS 1.05 TO 2.95 AND TR= ',
2 F5.2, ' ,Z IS IN ERROR.')
329      U = (2.*PR - 15.)/14.8
330      V = (2.*TR - 4.)/1.9
331      ZZ = .0
332      DO 2 I = 1,6
333      DO 1 J = 1,6
334      ZZ = ZZ + COEF(I,J)*POLSUB(I,V)*POLSUB(J,U)
335      1 CONTINUE
336      2 CONTINUE
337      RETURN
338      END
      C
      C
      C
      C

```

```

339          FUNCTION POLSUB(K,W)
          C
          C
          C
340          IMPLICIT REAL*8 (A-H,I-Q)
341          GO TO (1,2,3,4,5,6),K
342          1 POLSUB = .7071068
343          RETURN
344          2 POLSUB = 1.224745*W
345          RETURN
346          3 POLSUB = .7905695*(3*W**2 - 1)
347          RETURN
348          4 POLSUB = .9354145*(5*W**3 - 1)
349          RETURN
350          5 POLSUB = .265165*(35*W**4 - 30*W**2 + 3.)
351          RETURN
352          6 POLSUB = .293151*(63*W**5 - 70*W**3 + 15*W)
353          RETURN
354          END
          C
          C
          C
          C

```

```

355      SUBROUTINE IDSUB(VDD,C,IDI)
      C
      C
      C
356      INTEGER A,AMAX,H,BMAX,C,CMAX,D,DIST,DISTM,DISTMM,FLO
357      REAL ID(10,10)
358      DO 1 D = 1,10
359      ID(C,D) = VDD - .75 - D*.25
360      1 CONTINUE
361      RETURN
362      END
      C
      C
      C
      C

```



```

363      SUBROUTINE PIPOUT(R,NCONS,NLIFE,B,H,ALPHA)
      C
      C
      C
364      DIMENSION BETA(2),N1(5),LIFE(5)
365      COMMON /COMA/ M1,M2,FMAX,HMAX,MARR,LIFE,BPMAX,SPMAX,
      1      GASBP,GASSP,N1,PIPCAP,PIPMAI
366      INTEGER A,AMAX,B,BMAX,C,CMAX,D,DIST,DISTM,DISTMM,FLD
367      INTEGER F,FMAX,FLAG,H,HMAX,BP,BPMAX,SP,SPMAX
368      REAL GASBP(5),GASSP(5),MARR(5),PIPCAP(5),PIPMAI(5,5)
369      SPWF(NV,RV) = 1 / (1+RV)**NV
370      UPWF(NV,RV) = 1/RV * (1-1/(1+RV)**NV)
371      ALPHA = PIPCAP(B)/NCONS*UPWF(NCONS,R) + (PIPMAI(B,H) +
      1      .01*PIPCAP(B)) * UPWF(NCONS+NLIFE,R)
372      RETURN
373      END
      C
      C
      C
      C

```

```

374      SUBROUTINE POWOUT(R,NCONS,NLIFE,M1,M2,GP)
      C
      C
      C
375      DIMENSION BETA(2)
376      COMMON /COMB/ BETA
377      COMMON /COM1/ A ,AMAX,B ,BMAX,C ,CMAX,D,L,Q,OD,IO,ODO,IDO,POW
378      INTEGER A,B,C
379      REAL L(3),Q(5),OD(10),ID(10,10),LX(100),PX(100),ROX(100),BUX(100),
1      ODD(5,10),IDD(5,10,3),PUW(5,10,3,5)
380      SPWF(NV,RV) = 1 / (1+RV)**NV
381      UPWF(NV,RV) = 1/RV * (1-1/(1+RV)**NV)
382      N2 = NCONS + M1
383      N3 = N2 + M2
384      M3 = NLIFE - M1 - M2
385      POWCAP = 500. + .2*( POW(B,C,1,A)* SPWF(NCONS,R)
1      + POW(B,C,2,A)* SPWF(N2,R)
2      + POW(B,C,3,A)* SPWF(N3,R) )
386      POWOPE = 120.*UPWF(NLIFE,R)*SPWF(NCONS,R)
1      + POW(B,C,2,A)*UPWF(M1,R)*SPWF(NCONS,R)*GP*.365*.288
2      + POW(B,C,2,A)*UPWF(M2,R)*SPWF(N2,R)*GP*.365*.288
3      + POW(B,C,3,A)*UPWF(M3,R)*SPWF(N3,R)*GP*.365*.288
387      POWMAI = .005 * ( POW(B,C,1,A)*UPWF(M1,R)*SPWF(NCONS,R)
1      + POW(B,C,2,A)*UPWF(M2,R)*SPWF(N2,R)
2      + POW(B,C,3,A)*UPWF(M3,R)*SPWF(N3,R) )
388      BETA(A) = POWCAP + POWOPE + POWMAI
389      RETURN
390      END

```

C
C
C
C

```

391      SUBROUTINE GASPWF(R,NCONS,NLIFE,M1,M2,VQ,GAMMA)
      C
      C
      C
392      SPWF(NV,RV) = 1 / (1+RV)**NV
393      UPWF(NV,RV) = 1/RV * (1-1/(1+RV)**NV)
394      M3 = NLIFE - M1 - M2
395      GAMMA = VQ*365.* (1./2.*UPWF(M1,R)*SPWF(NCONS,R)
1          + 3./4.*UPWF(M2,R)*SPWF(NCONS,R)
2          + 1.   *UPWF(M3,R)*SPWF(NCONS+M1+M2,R) )
396      RETURN
397      END
      C
      C
      C
      C

```

```

398     SUBROUTINE OUT   ( VL,VQ,VOD)
      C
      C
      C
      C
399     COMMON /COM1/ A,AMAX,B,BMAX,C,CMAX,D,L,Q,OD,ID,ODD,IDD,POW
400     COMMON /COM2/ STEPL,RO1,RO2,G,PB,TB,K,P2,PC,TC,TF,FE,FF
401     COMMON /COM4/ IDPIPE,LX,PX,ROX,BUX,DISTMM,PAV,ROAV,BJAV,THP,N,U4P
402     INTEGER A,AMAX,B,BMAX,C,CMAX,D,DIST,DISTM,DISTMM,FLO
403     REAL IDPIPE
404     REAL L(3),Q(5),OD(10),ID(10,10),LX(100),PX(100),RUX(100),BUX(100),
      1     ODD(5,10),IDD(5,10,3),POW(5,10,3,5)
405     PRINT 31,VL,VQ,VOD,IDPIPE
406     31 FORMAT('1',50X,'RESULTS FOR L= ',F5.1,' ,Q= ',F5.1,' ,OD= ',F5.2,
      1     ' ,ID= ',F5.2)
407     DO 1 DIST = 1,DISTMM
408     DL = VL-LX(DIST)
409     PRINT 32,DL,PX(DIST),POX(DIST),BUX(DIST)
410     32 FORMAT(/,25X,'L= ',F5.1,20X,' , P= ',F6.1,' ,RD= ',F6.2,
      1     ' ,BU= ',F6.2)
411     1 CONTINUE
412     PRINT 33,PAV,ROAV,BUAV
413     33 FORMAT(/,25X,'AVERAGE PRESSURE IN SECTION WOULD BE ',F6.1,
      1     /,25X,'AVERAGE DENSITY IN SECTION WOULD BE ',F6.2,
      2     /,25X,'AVERAGE BUOYANCY IN SECTION WOULD BE ',F6.2)
414     PRINT 34,A,THP
415     34 FORMAT(/,' THE TOTAL HORSEPOWER NEEDED AT PUMPING STATION NO ',
      1     I2,' IS ',F6.0)
416     GO TO 3
417     ENTRY OUT1
418     DO 2 B=1,BMAX
419     PRINT 35,Q(B)
420     35 FORMAT('1',25X,'POSSIBLE CASES FOUND FEASIBLE FROM A STRUCTURE,',
      1     ' FLOW AND POWER REQUIREMENTS POINT OF VIEW,',
      2     /,50X,'FOR Q = ',F6.1,' MMSCF/D.',/,50X,'-----',
      3     '-----')
421     IF (AMAX.LE.2) GO TO 4
422     PRINT 36
423     36 FORMAT(/,'MESSAGE FROM OUT1: FORMAT ARE FOR AMAX=2 IN THE ',
      U     'PRESENT SUBPROGRAM, PROGRAM WAS STOPPED, PLEASE ',
      2     'REARRANGE FORMAT STATEMENTS.')
424     RETURN
425     4 DO 2 C=1,CMAX
426     PRINT 37,ODD(B,C),IDD(B,C,1),IDD(B,C,2)
427     37 FORMAT(/,'OD = ',F5.2,' INCHES AND',26X,'ID = ',F5.2,' IN.',
      1     36X,'ID = ',F5.2,' IN.')
428     PRINT 39,Q(B)/2.,POW(B,C,1,1),POW(B,C,1,2),Q(B)*3./4.,
      1     POW(3,C,2,1),POW(B,C,2,2),Q(B),POW(B,C,3,1),POW(B,C,3,2)
EXTENSION*     IO-C
EXTENSION*     IO-C
429     39 FORMAT(/,10X,F6.1,36X,F6.0,44X,F6.0,
      1     /,10X,F6.1,36X,F6.0,44X,F6.0,
      2     /,10X,F6.1,36X,F6.0,44X,F6.0)
430     2 CONTINUE
431     3 RETURN
432     END

```

C
C
C
C

433 BLOCK DATA

C
C
C
C

434 COMMON /COM3/ STEPLO,RO10,RO20,GO,P80,T80,K0,P20,PC0,TC0,TF0,FEO,
FFD
1 REAL STEPLO/10./,RO10/490./,RO20/64./,GO/.66/,P80/14.73/,
1 T80/520./,K0/.25E-3/,P20/700./,PC0/670./,TC0/360./,TF0/520./,
2 FEO/100./,FFD/.97/
END

C
C
C
C
C
C
C
C

DATA

\$DATA

MESSAGE FROM COMPUT: FOR L= 258.0 ,Q= 800.0 ,OD= 24.00 AND ID= 22.75
A BUOYANT LINE EXISTS, BUT PI/P2 IS GREATER THAN 2., WITH P2= 2378.8 PROGRAM WAS SENT TO NEXT COMPUTATION IN MAIN.

MESSAGE FROM COMPUT: FOR L= 240.0 ,Q= 800.0 ,OD= 24.00 AND ID= 22.75
A BUOYANT LINE EXISTS, BUT PI/P2 IS GREATER THAN 2., WITH P2= 2296.4 PROGRAM WAS SENT TO NEXT COMPUTATION IN MAIN.

MESSAGE FROM COMPUT: FOR L= 258.0 ,Q= 800.0 ,OD= 28.00 AND ID= 26.50
A BUOYANT LINE EXISTS, BUT PI/P2 IS GREATER THAN 2., WITH P2= 1684.3 PROGRAM WAS SENT TO NEXT COMPUTATION IN MAIN.

MESSAGE FROM COMPUT: FOR L= 240.0 ,Q= 800.0 ,OD= 28.00 AND ID= 26.50
A BUOYANT LINE EXISTS, BUT PI/P2 IS GREATER THAN 2., WITH P2= 1632.3 PROGRAM WAS SENT TO NEXT COMPUTATION IN MAIN.

MESSAGE FROM COMPUT: FOR L= 258.0 ,Q= 1200.0 ,OD= 24.00 AND ID= 22.75
A BUOYANT LINE EXISTS, BUT PI/P2 IS GREATER THAN 2., WITH P2= 3569.3 PROGRAM WAS SENT TO NEXT COMPUTATION IN MAIN.

MESSAGE FROM COMPUT: FOR L= 240.0 ,Q= 1200.0 ,OD= 24.00 AND ID= 22.75
A BUOYANT LINE EXISTS, BUT PI/P2 IS GREATER THAN 2., WITH P2= 3440.0 PROGRAM WAS SENT TO NEXT COMPUTATION IN MAIN.

MESSAGE FROM COMPUT: FOR L= 258.0 ,Q= 1200.0 ,OD= 28.00 AND ID= 26.50
A BUOYANT LINE EXISTS, BUT PI/P2 IS GREATER THAN 2., WITH P2= 2457.5 PROGRAM WAS SENT TO NEXT COMPUTATION IN MAIN.

MESSAGE FROM COMPUT: FOR L= 240.0 ,Q= 1200.0 ,OD= 28.00 AND ID= 26.50
A BUOYANT LINE EXISTS, BUT PI/P2 IS GREATER THAN 2., WITH P2= 2372.4 PROGRAM WAS SENT TO NEXT COMPUTATION IN MAIN.

MESSAGE FROM COMPUT: FOR L= 258.0 ,Q= 1200.0 ,OD= 30.00 AND ID= 28.25
A BUOYANT LINE EXISTS, BUT PI/P2 IS GREATER THAN 2., WITH P2= 2114.6 PROGRAM WAS SENT TO NEXT COMPUTATION IN MAIN.

MESSAGE FROM COMPUT: FOR L= 240.0 ,Q= 1200.0 ,OD= 30.00 AND ID= 28.25
A BUOYANT LINE EXISTS, BUT PI/P2 IS GREATER THAN 2., WITH P2= 2043.8 PROGRAM WAS SENT TO NEXT COMPUTATION IN MAIN.

MESSAGE FROM COMPUT: FOR L= 258.0 ,Q= 1200.0 ,OD= 32.00 AND ID= 30.25
A BUOYANT LINE EXISTS, BUT PI/P2 IS GREATER THAN 2., WITH P2= 1812.6 PROGRAM WAS SENT TO NEXT COMPUTATION IN MAIN.

MESSAGE FROM COMPUT: FOR L= 240.0 ,Q= 1200.0 ,OD= 32.00 AND ID= 30.25
A BUOYANT LINE EXISTS, BUT PI/P2 IS GREATER THAN 2., WITH P2= 1754.9 PROGRAM WAS SENT TO NEXT COMPUTATION IN MAIN.

MESSAGE FROM COMPUT: FOR L= 258.0 ,Q= 1200.0 ,OD= 34.00 AND ID= 32.00
A BUOYANT LINE EXISTS, BUT PI/P2 IS GREATER THAN 2., WITH P2= 1607.2 PROGRAM WAS SENT TO NEXT COMPUTATION IN MAIN.

RATE OF INTEREST : 8.0 PER CENT.

EXPECTED LIFE OF PIPELINE : 10 YEARS.

FLOW RATE : 400.0 MMSCF/D.

LINE DIAMETER : 24.00 IN.

GAS BOUGHT AT 0.10 DOLLARS/MSCF.
AND CHARGED 0.33 DOLLARS/MSCF
AT STATION 2.

SELLING PRICE RATE OF RETURN
(DOLLARS/MSCF) ON INVESTMENT

THIS PROPOSAL NOT FEASIBLE FOR GAS SELLING PRICE AT 0.40 \$/MSCF IN FRANCE.

THIS PROPOSAL NOT FEASIBLE FOR GAS SELLING PRICE AT 0.45 \$/MSCF IN FRANCE.

THIS PROPOSAL NOT FEASIBLE FOR GAS SELLING PRICE AT 0.50 \$/MSCF IN FRANCE.

FLOW RATE : 800.0 MMSCF/D.

LINE DIAMETER : 24.00 IN.

LINE DIAMETER : 28.00 IN.

LINE DIAMETER : 30.00 IN.

278

GAS BOUGHT AT 0.10 DOLLARS/MSCF.
AND CHARGED 0.28 DOLLARS/MSCF
AT STATION 2.

SELLING PRICE RATE OF RETURN
(DOLLARS/MSCF) ON INVESTMENT

THIS PROPOSAL NOT FEASIBLE FOR GAS SELLING PRICE AT 0.40 \$/MSCF IN FRANCE.

0.45 9.0 PER CENT.

0.50 12.5 PER CENT.

FLOW RATE : 1200.0 MMSCF/D.

LINE DIAMETER : 24.00 IN.

LINE DIAMETER : 28.00 IN.

LINE DIAMETER : 30.00 IN.

LINE DIAMETER : 32.00 IN.

LINE DIAMETER : 34.00 IN.

LINE DIAMETER : 36.00 IN.

GAS BOUGHT AT 0.10 DOLLARS/MSCF.

AND CHARGED 0.25 DOLLARS/MSCF
AT STATION 2.

SELLING PRICE (DOLLARS/MSCF)	RATE OF RETURN ON INVESTMENT
0.40	9.5 PER CENT.
0.45	13.5 PER CENT.
0.50	17.5 PER CENT.

EXPECTED LIFE OF PIPELINE : 15 YEARS.

FLOW RATE : 400.0 MMSCF/D.

LINE DIAMETER : 24.00 IN.

GAS BOUGHT AT 0.10 DOLLARS/MSCF.
AND CHARGED 0.27 DOLLARS/MSCF
AT STATION 2.

SELLING PRICE (DOLLARS/MSCF)	RATE OF RETURN ON INVESTMENT
0.45	9.0 PER CENT.
0.50	12.0 PER CENT.

THIS PROPOSAL NOT FEASIBLE FOR GAS SELLING PRICE AT 0.40 \$/MSCF IN FRANCE.

279

FLOW RATE : 800.0 MMSCF/D.

LINE DIAMETER : 24.00 IN.

LINE DIAMETER : 28.00 IN.

LINE DIAMETER : 30.00 IN.

GAS BOUGHT AT 0.10 DOLLARS/MSCF.
AND CHARGED 0.23 DOLLARS/MSCF
AT STATION 2.

SELLING PRICE (DOLLARS/MSCF)	RATE OF RETURN ON INVESTMENT
0.40	11.5 PER CENT.
0.45	14.5 PER CENT.
0.50	17.5 PER CENT.

FLOW RATE : 1200.0 MMSCF/D.

LINE DIAMETER : 24.00 IN.

LINE DIAMETER : 28.00 IN.

LINE DIAMETER : 30.00 IN.

LINE DIAMETER : 32.00 IN.
 LINE DIAMETER : 34.00 IN.
 LINE DIAMETER : 36.00 IN.

GAS BOUGHT AT 0.10 DOLLARS/MSCF.
 AND CHARGED 0.21 DOLLARS/MSCF
 AT STATION 2.

SELLING PRICE (DOLLARS/MSCF)	RATE OF RETURN ON INVESTMENT
0.40	15.0 PER CENT.
0.45	18.0 PER CENT.
0.50	21.5 PER CENT.

 EXPECTED LIFE OF PIPELINE : 20 YEARS.

FLOW RATE : 400.0 MMSCF/D.

LINE DIAMETER : 24.00 IN.

GAS BOUGHT AT 0.10 DOLLARS/MSCF.
 AND CHARGED 0.25 DOLLARS/MSCF
 AT STATION 2.

SELLING PRICE (DOLLARS/MSCF)	RATE OF RETURN ON INVESTMENT
0.40	9.5 PER CENT.
0.45	12.0 PER CENT.
0.50	14.5 PER CENT.

FLOW RATE : 800.0 MMSCF/D.

LINE DIAMETER : 24.00 IN.
 LINE DIAMETER : 28.00 IN.
 LINE DIAMETER : 30.00 IN.

GAS BOUGHT AT 0.10 DOLLARS/MSCF.
 AND CHARGED 0.21 DOLLARS/MSCF
 AT STATION 2.

SELLING PRICE (DOLLARS/MSCF)	RATE OF RETURN ON INVESTMENT
0.40	13.5 PER CENT.
0.45	16.5 PER CENT.
0.50	19.0 PER CENT.

FLOW RATE : 1200.0 MMSCF/D.

- LINE DIAMETER : 24.00 IN.
- LINE DIAMETER : 28.00 IN.
- LINE DIAMETER : 30.00 IN.
- LINE DIAMETER : 32.00 IN.
- LINE DIAMETER : 34.00 IN.
- LINE DIAMETER : 36.00 IN.

GAS BOUGHT AT 0.10 DOLLARS/MSCF.
AND CHARGED 0.19 DOLLARS/MSCF
AT STATION 2.

SELLING PRICE (DOLLARS/MSCF)	RATE OF RETURN ON INVESTMENT
0.40	17.0 PER CENT.
0.45	20.0 PER CENT.
0.50	23.0 PER CENT.

United States Steel Corporation

525 WILLIAM PENN PLACE

Pittsburgh, Pa.

J. H. GALLAND
MANAGER

WIRE ROPE & ELECTRICAL CABLE PRODUCTS

H. T. CHESTER
SENIOR PRODUCT ENGINEER
WIRE ROPE PRODUCTS

WIRE PRODUCTS SALES



TIGER BRAND WIRE ROPE

TELEPHONE
AREA CODE 212
558-4801

MAILING ADDRESS:
71 BROADWAY
NEW YORK, NEW YORK 10006

January 20, 1970

Professor G.H. Savage
Department of Petroleum Engineering
Stanford University
Stanford, California 94305

SUBJECT: OFFSHORE TOWER SYSTEM

Dear Sir:

With reference to our telephone conversation, you will find enclosed curves showing load strain characteristics of typical wire ropes and of our 3X19 construction with elevated elastic limit. The material in the latter ropes is very stable, in its stress strain relationship. Repeated loading, within the elastic limits, does not change the relationship shown.

You will also find enclosed Table No. 1 of U.S.S. Torque Balanced Ropes. This chart supplements the brochure that you have by giving weights in air and water for ropes with or without extruded jackets. The degree to which plastic jacketing increases the buoyancy of the cable in sea water is shown in Table 1. This is made possible by incapsulating the many internal voids of the 3-strand construction. In very deep water the pressures will compress the jacket into the interstices of the rope. However, the maximum stress encountered in a buoy's mooring should be near the surface where the water pressure is less and the increased buoyancy is helpful.

It is well known that the plastic jacket will enable the steel rope to resist corrosion in sea water as long as it is intact. We are still testing to determine whether corrosion will continue if the jacket is pierced by small holes caused by fish bites. It is suspected that even though the jacket will leak, the oxygen supply will become depleted.

I trust the information herein will answer your immediate questions concerning our Oceanographic Wire Ropes. We are sincerely interested in your project and would be happy to discuss any aspects of our products in detail with you.

Very truly yours,

UNITED STATES STEEL CORPORATION

H.T. Chester
H.T. Chester, Senior Product Engineer,
Wire Rope Products

FH

3 x 7, 3 x 19 AND 3 x 46 TORQUE-BALANCED ROPES W/TE AND WITHOUT A JACKET

Bright Dr. Amgal Monitor AA Torque-Balanced Rope										Polyurethane Jacketed Rope			Polyethylene Jacketed Rope		
Size Inches	Construction	Weight In Air, Lbs./Ft.	Weight In Water, Lbs./Ft.	Breaking Load, Pounds	2% Yield Strength, Pounds	Maximum Length		Jacket Dimensions		Polyurethane Jacketed Rope			Polyethylene Jacketed Rope		
						Present, Feet	Proposed, Feet	Thick-ness, Inches	O. D., Inches	Jacket Weight, Lbs./Ft.	Weight In Air, Lbs./Ft.	Weight In Water, Lbs./Ft.	Jacket Weight, Lbs./Ft.	Weight In Air, Lbs./Ft.	Weight In Water, Lbs./Ft.
5/32	3x7	.0402	.0349	2,800	2,460	60,000		.032	.237	.016	.056	.037	.011	.052	.032
3/16	3x19 Seale	.0586	.0509	4,000	3,500	50,000		.032	.269	.019	.078	.052	.014	.073	.047
1/4	3x19 Seale	.0997	.0867	6,750	5,900	45,000		.032	.329	.026	.126	.088	.019	.119	.081
5/16	3x19 Seale	.153	.133	10,300	9,100	30,000		.032	.392	.035	.188	.134	.026	.179	.125
3/8	3x19 Seale	.220	.191	14,800	13,000	50,000		.032	.456	.045	.265	.192	.033	.253	.181
7/16	3x19 Seale	.304	.264	20,000	17,600	42,000		.032	.524	.057	.361	.265	.042	.346	.250
1/2	3x19 Seale	.392	.341	25,700	22,600	32,000	98,000	.080	.682	.120	.512	.350	.090	.482	.319
9/16	3x19 Seale	.492	.428	32,500	28,600	25,000	77,000	.080	.746	.139	.631	.437	.104	.596	.402
5/8	3x19 Seale	.602	.523	40,300	35,500	20,000	62,000	.080	.807	.158	.760	.533	.118	.720	.493
3/4	3x19 Seale	.879	.764	57,800	50,900	14,300	43,000	.080	.941	.204	1.08	.774	.152	1.03	.722
7/8	3x19 Seale	1.21	1.05	78,000	68,600	10,400	32,000	.080	1.077	.255	1.46	1.06	.190	1.40	.995
1	3x19 Seale	1.56	1.36	100,600	88,500	8,000	24,000	.080	1.201	.306	1.87	1.36	.228	1.79	1.28
1-1/8	3x19 Seale	1.96	1.70	124,000	109,000	6,400	19,000	.080	1.326	.362	2.32	1.71	.270	2.23	1.62
1/2	3x46 Seale FV	.417	.362	25,700	22,600	31,000	98,000	.080	.688	.122	.539	.374	.091	.508	.343
9/16	3x46 Seale FV	.517	.449	32,500	28,600	25,000	77,000	.080	.747	.140	.657	.462	.104	.621	.426
5/8	3x46 Seale FV	.631	.548	40,300	35,500	20,000	62,000	.080	.809	.159	.790	.562	.118	.749	.521
3/4	3x46 Seale FV	.903	.785	57,800	50,900	14,500	43,000	.080	.936	.202	1.10	.799	.150	1.05	.748
7/8	3x46 Seale FV	1.27	1.10	78,000	68,600	10,300	32,000	.080	1.078	.255	1.52	1.12	.190	1.46	1.05
1	3x46 Seale FV	1.64	1.43	100,600	88,500	8,000	24,000	.080	1.205	.308	1.95	1.44	.229	1.87	1.36
1-1/8	3x46 Seale FV	2.07	1.85	124,000	109,000	6,300	19,000	.080	1.332	.365	2.44	1.82	.272	2.34	1.72
1-1/4	3x46 Seale FV	2.60	2.26	158,000	139,000	5,000	15,500	.100	1.514	.485	3.08	2.29	.362	2.96	2.16
1-3/8	3x46 Seale FV	3.10	2.69	188,000	165,000	4,200	12,900	.100	1.637	.554	3.65	2.72	.413	3.51	2.58
1-1/2	3x46 Seale FV	3.69	3.21	222,000	195,000	3,500	10,800	.110	1.784	.660	4.35	3.24	.492	4.18	3.07
1-5/8	3x46 Seale FV	4.43	3.85	265,000	233,000	2,900	9,200	.110	1.938	.760	5.19	3.88	.567	5.00	3.69
1-3/4	3x46 Seale FV	5.12	4.45	304,000	267,000	2,500	8,000	.110	2.063	.847	5.97	4.48	.631	5.75	4.27

TABLE 1

• STANFORD UNIVERSITY • OFFICE MEMORANDUM • STANFORD UNIVERSITY • OFFICE MEMORANDUM • STANFORD UNIVERSITY • OFFICE MEMORANDUM

DATE: January 16, 1970

To : Sullivan S. Marsden, Jr.
 Petroleum Engineering

FROM : Godfrey H. Savage

SUBJECT: COST OF FLOTATION, BOTH MAIN METAL BUOYS AND GLASS FLOAT CABLES

By telephone, I received the following cost quotations which I requested from Rohr Corporation, San Diego, California (sales volume currently \$400-million annually). Rohr manufactured the large ellipsoidal aluminum chambers for both Sea Spider I and Sea Spider II (24,000 lbs. net buoyancy). These metal buoys will be used to hold up the towers prior to attachment of the pipeline. Rohr has promised to substantiate these quotes in writing (Mr. Charles Kayte, Marketing Department and Mr. Thomas Collard, Program Manager for Marine Products).

Attached is a zerox copy of a letter from Corning Glass on the cost of glass flotation. The cablemate floats have hard plastic covers with eyes for attaching to steel cables; therefore the higher costs over a plain glass sphere. These spheres test to 10,000 psi.

GHS:lg

(2/1)

cc: F. G. Miller
 R. L. Street
 P. L. Boutin

TABLE OF ROHR QUOTATION

Net Buoyancy (1000 lbs.)	20	30	40	50
Spherical Shape				
-Unit Cost Lot Size 100	\$11,725	\$12,054	\$13,421	\$15,861
-Unit Cost Lot Size 200	\$10,396	\$10,567	\$12,005	\$15,409
Elliptical Shape				
-Unit cost Lot Size 100	\$11,623	\$13,509	\$15,536	\$15,816
-Unit Cost Lot Size 200	\$10,248	\$12,098	\$14,075	\$14,333
Diameter, Spherical Shape (ft.)	8.48	9.72	10.7	11.52
Diameters, Elliptical Shape (ft.)	10.5 5.25	12.25 6.13	13.5 6.75	14.5 7.25

NOTE: This cost is for a buoy of 6061-T4 Al, chambered in eight slices for safety against puncture. Maximum pressure, 500 psia (1000 feet plus). All welded construction with external pad eyes.

CORNING GLASS WORKS
CORNING
CORNING, NEW YORK 14830

HYDROSPACE DEPARTMENT

24 December 1969

TEL: 607 862-4444

Stanford University
Petroleum Engineering Dept.
Stanford, California 94305

Attention: Mr. Jeff H. Savage

Dear Mr. Savage:

Your concept of implanting a network of three point moored stabilized platform to support an underwater natural gas line is very interesting. After discussing this concept with our engineering group, it is felt that the concept is feasible and that the deciding factor is merely one of economics.

As you are aware Corning supplies the buoyancy packages for the Navy's Sea Spider program and also for similar systems used by ESSA. We are definitely interest in supplying the buoyancy needed for the network which you have described and hope that your concept is received favorably by the National Science Foundation.

Per your request, I have examined the price/volume relationship for Corning's Floats and Cablemates and hope that the following information will be useful in putting together the total expected cost for your proposed system.

<u>Diameter</u>	<u>Code</u>	<u>Dry Wgt. (Lbs)</u>	<u>Net Buoyancy (Lbs)</u>	<u>Estimated Unit Price In Lots of 50,000 pieces</u>
10"Float	691071	7.2	12.6	\$10.00
10"Cable mate	690228	9.0	12.6	12.00
16"Float	698018	31.5	48.8	40.00
16"Cable mate	690496	37.5	48.8	48.00

CORNING GLASS WORKS • CORNING • NEW YORK

Stanford University
Mr. Jeff H. Savage
24 December 1969
page 2

The above prices are provided for your planning purposes and should not be considered as a firm fixed price. It is our feeling, however, that the above prices are realistic and would remain relatively constant during the next two to three years. Delivery schedules are somewhat harder to predict but for planning purposes assume that the 10" versions could be shipped within 6-8 months after receipt of order and the 16" versions could be shipped within 12-18 months after receipt of order. If these delivery schedules are not acceptable I am sure that, within reason, we can shorten this schedule.

I hope that I have been able to provide you with the information you needed and we at Corning wish you success in your endeavors. If any additional information is needed please do not hesitate to call upon us. With best personal regards, I remain,

Sincerely yours,

CORNING GLASS WORKS



Gerald N. Moore
Advanced Products Dept.

.a

DATE: January 16, 1970

TO : Sullivan S. Marsden, Jr.
Petroleum Engineering

FROM : Godfrey H. Savage

SUBJECT: INTERVIEW WITH SAM SMALL, BECHTEL CORPORATION

On Tuesday, December 23, I met with Mr. Sam Small, Head of Marine Pipeline Engineering, Bechtel Corporation, to discuss construction costs

Basing the pipeline construction on present methods, Small estimates that the entire flotilla of equipment: pipelaying ship, supply barges, tugs, equipment and personnel, will cost \$50,000 per day to operate.

The key to the cost is the welding with Small estimating that they could make 3 welds per hour on a 30-inch diameter pipe. This is accomplished by having welding done at 5 separate stations on each 40-foot section of pipe. The only way the process could be speeded up would be to use longer sections, but then a larger ship would be required. At the present time however, using presently proven methods, we could not expect to lay more than 3000 feet of pipe per day (24 hour day). This is a cost of \$17 per foot if no delays for weather and exclusive of materials and cost of wedding the pipe to the subsurface structure.

The safety valves we have discussed (bag valves to seal pipe in the event of leaks - quick release valves) might cost \$15,000 per unit including the control if we base the cost on present quick release gate valves for high pressure.

The pipe type used for marine work in API-5L-5LX. They find Japanese pipe excellent and price advantageous.

Discussing the costs of laying bottom mounted pipe out to a depth where it could float undisturbed by bottom effects, Small suggested \$5000/inch diameter/mile, exclusive of materials, as a rule of thumb. The Oil and Gas Journal (September 15, 1969) estimates a cost of \$2.50 to \$3.00 per foot per inch diameter for pipeline laid in 90 feet of water or \$15,000/inch diameter/mile including materials. The figures are consistent.

Asked about corrosion, Small said that their concrete coating on marine lines has been demonstrated to last 20 years, but they also use electric charge and cathodic protection and do not have major problems in marine lines. I was very surprised. They use a 7¹¹ concrete coating on marine lines.

It is difficult to project much of present methodology into the construction of a floating line, but these figures and opinions are only kind of basis we have.

GHS:lg

cc: F. G. Miller, R. L. Street, P. L. Boutin

SUBJECT: PIPE AND CABLE COST INFORMATION GIVEN

BY MR. G. H. BONGERS, BECHTEL CORPORATION

On Tuesday July 21, Mr. Bongers, at the request of Mr. Lee Snyder, telephoned the following information on pipe prices for type X52.

24 inch OD, 5/8 inch wall - \$13 to \$14 per foot

30 inch OD, 5/8 inch wall - \$17 to \$18 per foot

36 inch OD, 1 inch wall - \$40 to \$50 per foot

These prices were European prices, probably Italian. He noted that the 1 inch wall thickness pipe was unusual and the price was a rough estimate.

Cable prices were as follows.

Diam.	type	Price/ft
1/2 inch	3 x 19	.254
3/4 inch	3 x 19	.573
1 inch	3 x 19	.784
1-1/8 inch	3 x 19	.972

These were U.S. prices forunjacketed steel bridge cable. Shipping and plastic coating costs should be added.

G. H. SAVAGE

