



*Moss
Landing*

*Marine
Laboratories*
CIRCULATING COPY
Sea Grant Depository

Technical Publication 72-6

A SHORT SURVEY OF THE ENVIRONMENT AT THE
DUMPING SITE FOR SANTA CRUZ HARBOR DREDGING

and

A STUDY OF SEAWARD DIPPING INTERNAL STRUCTURES
IN MARINE RIPPLE MARKS AT WHALER'S COVE, CALIFORNIA

by

Robert E. Arnal
Lawrence C. Leopold

Annual Report, Part 4, August 1972

A NATIONAL SEA GRANT PROJECT

supported by the
OFFICE OF SEA GRANT PROGRAMS
NATIONAL OCEANIC AND ATMOSPHERIC ADMINISTRATION
DEPARTMENT OF COMMERCE
Grant No. 2-35137

Robert E. Arnal, Sea Grant Project Coordinator

Moss Landing Marine Laboratories
of the
California State University
at
Fresno, Hayward, Sacramento, San Francisco, and San Jose

CIRCULATING COPY
Sea Grant Depository

Contributions from the Moss Landing Marine Laboratories No. 31
Technical Publication 72-6
CASUC-MLML-TP-72-06

A SHORT SURVEY OF THE ENVIRONMENT AT THE
DUMPING SITE FOR SANTA CRUZ HARBOR DREDGING

by

Robert E. Arnal

1972

Moss Landing Marine Laboratories
of the
California State University
at
Fresno, Hayward, Sacramento, San Francisco, and San Jose

TABLE OF CONTENTS

	Page
INTRODUCTION	1
ACKNOWLEDGEMENTS	1
SURVEY OF THE ENVIRONMENT	2
Local Surface Currents	2
Bottom Topography	5
Sediments at the Dredge Site	8
Sediments at the Disposal Site	11
Rough Benthic Survey	11
Summary	14
References	18

LIST OF FIGURES

1 - Summary of current observations for periods indicated.	3
2 - Bottom topography and location of sampling profiles.	6
3 - Comparison of grain-size and organic content for dredge spoil sediments.	10
4 - Location of each sampling station in relation to disposal site P.	13
5 - Pie-diagram showing proportion of major groups of benthic organisms.	15

LIST OF TABLES

of 33 processed samples	16
for 33 processed samples	17
	2 - Biological data

INTRODUCTION

The Santa Cruz Harbor District proposed in late 1970 an expansion of the small craft harbor for the city of Santa Cruz. This expansion was to provide berthing facilities for 400 additional boats. Considerable dredging of the harbor, thus, was necessary. Massachusetts Marine Laboratories agreed to conduct a short survey of the environment at the dumping site of the dredge spoil prior to dumping and to conduct a certain amount of monitoring at the dumping site during dredging operations. Scientists at the Laboratories in early 1971 provided a preliminary advisory report regarding the best dumping site location. Final location of the dumping site was decided after consultation with the California Department of Fish and Game to be on the 122°00' west longitude meridian at the intersection with the 5 fathom contour. Dredging was performed with a pipe dredge that delivered the dredge spoil by means of a floating pipeline more than 3,000 feet long to the dumping site where the end of the pipe was always located near the bottom.

ACKNOWLEDGEMENTS

Six graduate and upper division students completed field and samples in the field and conducted laboratory analyses and observations. Thus, the contribution of Genny Anderson, Shane Anderson, Eric Dittmer, Dave Lewis, Steve Pace, and Ed Stark is fully acknowledged. The data they obtained form the basis of this open file.

report and are summarized in the following paragraphs. Part of this research was supported by Grant No. 2-35137 from the Office of Sea Grant Programs, National Oceanic and Atmospheric Administration, Department of Commerce.

SURVEY OF THE ENVIRONMENT

Local Surface Currents Early in 1971 the current pattern for surface waters had been observed many times but only for short continuous periods. Taking advantage of the monitoring requirements for this project, current measurements were made of the surface waters approximately at bi-weekly intervals for a full yearly cycle. These measurements were made for the region of Santa Cruz Harbor with the observation site at the end of the Santa Cruz Pier. The currents in Monterey Bay are very much affected by seasonal changes and three periods (Skogsberg 1936) are generally recognized during the year: 1) the period of the Davidson Current lasting from Mid-November to Mid-February; 2) the upwelling period from Mid-February to end July; and 3) the oceanic period from end July to Mid-November. Off Monterey Bay, the California Current during the greater part of the year is directed to the south. During the winter season, however, the Davidson Current often is present as an inshore flow to the north. The seasonal current pattern of Monterey Bay is very evident also in Santa Cruz Harbor between Point Santa Cruz and Point Soquel. Figure 1 shows the general current pattern for the Santa Cruz Harbor region for the three oceanographic periods mentioned above. The surface current direction during

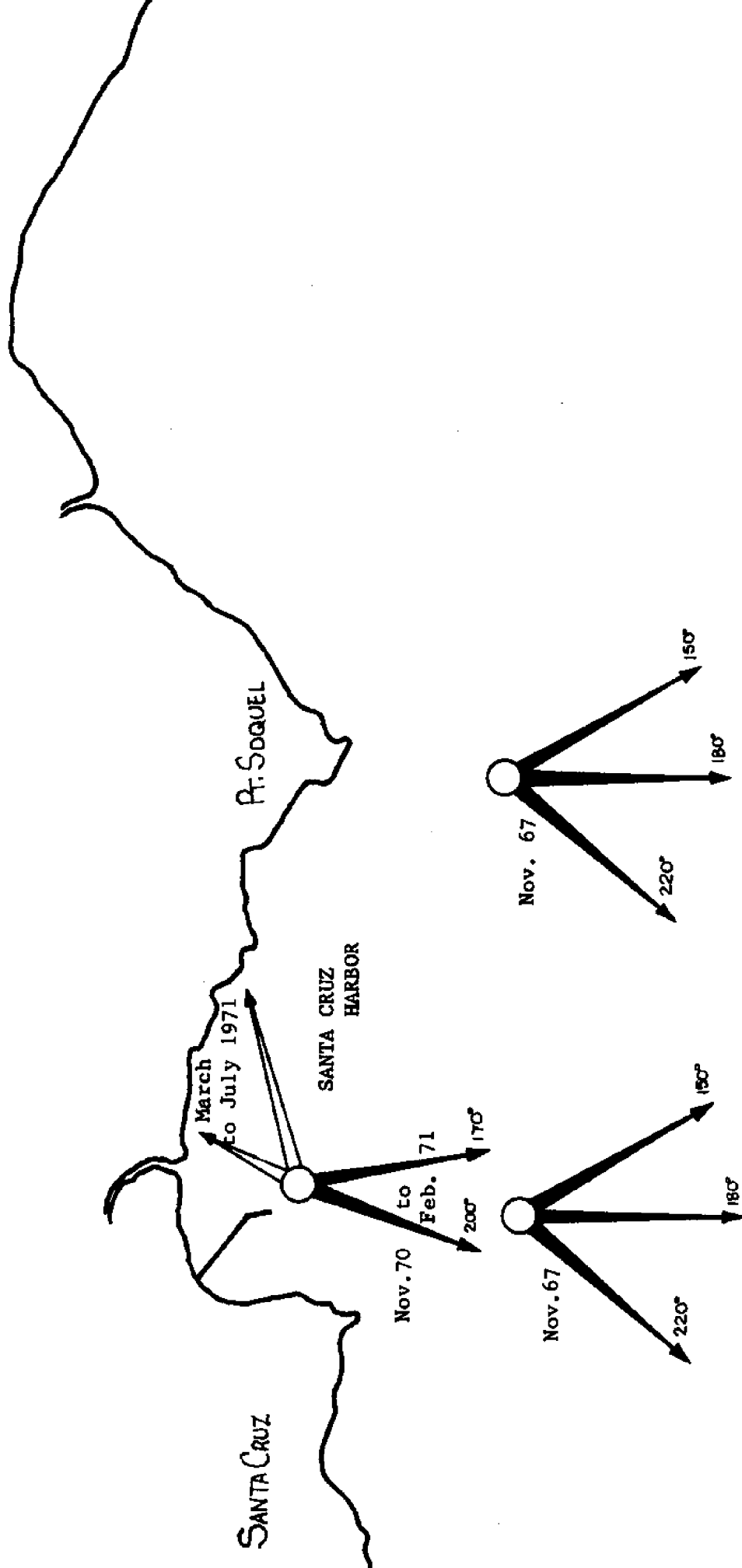

Figure 1. Summary of current observations for periods indicated. (see text for details)

the Davidson Current period was verified on several occasions. In 1967, aboard the Coast and Geodetic Survey ship "Davidson", a study of the currents of Monterey Bay was made during the month of November. At that time, the current pattern showed a flow with a southerly direction in the vicinity of Santa Cruz. This southerly flow was particularly evident due south of the San Lorenzo River mouth and also in the vicinity of Soquel Point. Current flow measurements made at regular intervals in November and December 1970 showed a similar pattern at the end of Santa Cruz Pier. The direction of flow there had a bearing of true 170° in agreement with the observations made in November 1967. Recently, November 2, 1971, a final observation was made with a bearing of true 200° indicating that this year the Davidson Current period may start earlier than usual.

~~The winter pattern of currents observed in November-December~~

1970, continued until the first week of February 1971. Later during the same month the current pattern changed to that of the upwelling period with a direction nearly to the east with a true bearing of 70° . The same general wind driven direction continued in March and April with a tendency to become more northerly in May, June and July. During the upwelling period the wind direction is very apparent as the driving force and in general the current pattern has a true bearing of 40° to 70° , but may be as northerly as 20° in the last portion of the upwelling period.

During the summer months, and in October also, the currents are sometimes sluggish in the Santa Cruz Harbor region; this is a period of relative calm with somewhat irregular currents; however, not

enough measurements were made during the summer to establish a definite direction during that period.

Longshore currents which represent mostly the water motion within the surf zone, 200 to 500 feet wide, agree only in a very general way with the current patterns described in preceding paragraphs. In general the motion is downcoast, i.e. eastward in the Santa Cruz vicinity during late spring, summer and fall. During the winter season and early spring the motion is upcoast (westward for Santa Cruz vicinity) as this is the time of the winter storms with wave arrival mostly from the south.

It is not uncommon during any month to have a reversal of the general longshore direction for that month, usually when the wind from a passing storm drives the surface water of the bay in a direction opposite to that prevailing at the time.

Bottom Topography

The bottom topography of the harbor is dependent on the

nature of the substratum. Steeper slopes at the points where rocks crop out and an anchoring system of kelp and other algae. Near Point Santa Cruz the shoreline is oriented north-south with steep slopes and a very rocky substratum. There, wave re-

fraction (Johnson et al. 1968) are observed near the mouth of the harbor and provide a secure area for the growth of algae. Near Point Santa Cruz with steep slopes and a very

fraction (Johnson et al. 1968) are observed near the mouth of the harbor and provide a secure area for the growth of algae. Near Point Santa Cruz with steep slopes and a very rocky substratum. There, wave re-

fraction (Johnson et al. 1968) are observed near the mouth of the harbor and provide a secure area for the growth of algae. Near Point Santa Cruz with steep slopes and a very rocky substratum. There, wave re-

fraction (Johnson et al. 1968) are observed near the mouth of the harbor and provide a secure area for the growth of algae. Near Point Santa Cruz with steep slopes and a very rocky substratum. There, wave re-

fraction (Johnson et al. 1968) are observed near the mouth of the harbor and provide a secure area for the growth of algae. Near Point Santa Cruz with steep slopes and a very rocky substratum. There, wave re-

fraction (Johnson et al. 1968) are observed near the mouth of the harbor and provide a secure area for the growth of algae. Near Point Santa Cruz with steep slopes and a very rocky substratum. There, wave re-

fraction (Johnson et al. 1968) are observed near the mouth of the harbor and provide a secure area for the growth of algae. Near Point Santa Cruz with steep slopes and a very rocky substratum. There, wave re-

1" = 4000'
 in feet below MLW
 (water) contour interval
 D, E, F, G profile
 20 samples each 250'
 (1) one grab sample
 Sites B, D, F. Disposed
 SAN LO



Six feet.
 1250' from P,
 each 2000' along
 site was at P

Figure 2
 Bottom topography and
 location of sampling profiles.

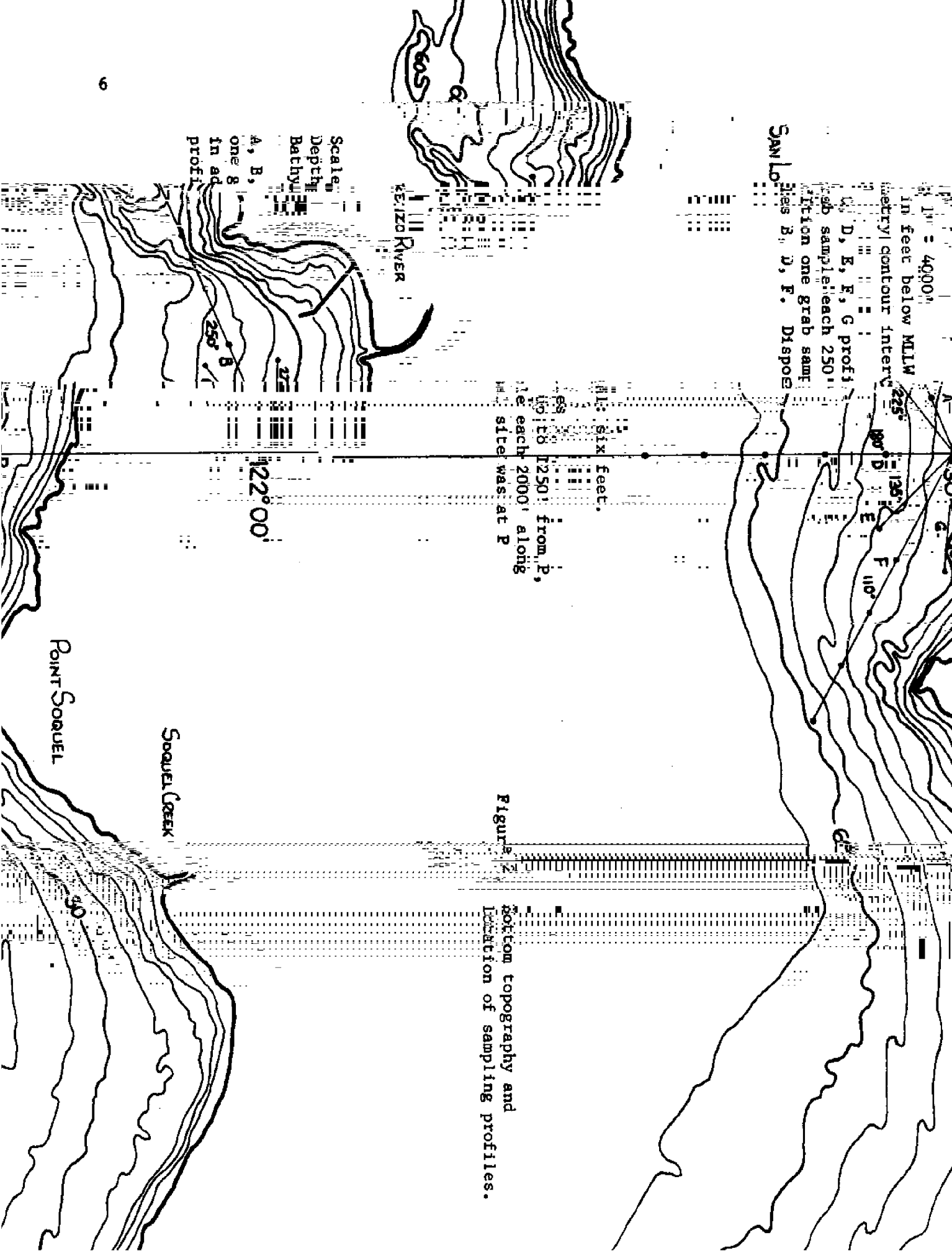

Scale
 Depth
 Bathymetry
 A, B,
 one 8
 in ad
 profil

outcroppings where an abundance of fine grained sediments would be expected by transport as bed load of the river during the rainy season. Much of the sediments delivered by the San Lorenzo River are deposited near the mouth of the river and often form sand bars. The sand is spread to the east or the west, depending on the prevailing direction of wave travel, but remains in fairly shallow water. During sampling operations it was found that at depth beyond 30 feet near the dumping site there is often only a thin layer of sand over a harder substratum of compacted clay.

Monitoring of the dumping site toward the end of dredging operations was done, with the cooperation of the Santa Cruz Port Director. Depth measurements by means of a fathometer on board the vessel off Santa Cruz Harbor, showed several small mounds rising 10 to 12 feet above the bottom; these marked the location of the end of the dredge pipe that was moved several times in order to consistently deliver the dredge spoil in water depths greater than 20 feet. It would be very desirable to re-survey the same area in the later spring of 1972 to assess the effect of winter storm waves on these underwater mounds of loose water-saturated sediments. If past experience in the vicinity of Moss Landing is verified, it is very likely that these mounds will be destroyed and the sediments spread over the bottom in the surrounding area. Since a rapid survey of benthic animals was made before dumping, a new rapid survey would establish whether or not the dredge spoil has been dispersed and if the disposal site area has been repopulated after the dispersal has taken place.

Sediments at the Dredge Site A total of 60 samples were collected in a grid pattern at the dredge site. Of these, 49 were processed by mechanical analysis (Krumbein and Pettijohn 1938) for sedimentary characteristics using the Emery (1939) settling tube method for determination of median diameter (Rubey 1933) and sorting coefficient. The samples on the average are made up of 6.8% coarse sand, 75.5% medium and fine sand and 17.7% silt and clay-size particles. The average median diameter of all the samples was calculated to be 0.194 mm which is in the fine sand range, but definitely skewed toward the medium range. For all samples processed by mechanical analysis the sorting coefficient was also calculated. It ranges from excellent sorting with a sample having a value as low as 1.16 (a perfect sorting with all grains exactly the same size would have a value of 1.0) to medium sorting with a sample having a coefficient of 2.59. In general the samples are fairly well sorted, the average value is 1.87, which is higher than the average at the dumping site in the ocean. This is to be expected because the dredge site is a small natural basin where both silt and sand particles would have a chance to accumulate; the site also received even finer particles from the soil of the surrounding area.

The percentage of organic content of the sediment was determined by the rapid potassium dichromate oxidation method as described by Allison (1935) in soil science. This method is useful for rapid comparison of organic content of samples from the same vicinity.

In normal, natural site of deposition the organic content in the sediments usually varies in a fashion inversely proportional to the grain size; the finer grained sediments having a higher content than the

coarser ones. This is usually due to quieter conditions of deposition which favor both the settling of fine particles and of organic material. The average organic content for all the samples analyzed was a high value of 5.37%.

Figure 3 shows the percentage of organic matter in the sediments plotted against the median diameter. The usual increase with decrease in size does not show at all, instead there is a cluster of values between 5 and 9% of organic matter regardless of the size of the sedimentary particles. These values of organic content are extremely high since sediments of the same size-ranges usually have a content of 1 to 2% and often less than 1%. The high values are undoubtedly due to the effect of man; the dredge site was filled in many places with oily substances dumped by people and for a while was almost a refuse site although it was never supposed to be that way. Abundant plant fragments from the surrounding vegetation also accumulated at the dredge site. High organic content often goes together with black color and the decomposition of organic matter creates reducing conditions with the usual hydrogen sulfide odor. All of these were observed at the dredge site. Much of the organic matter remained in the sediments; when they were deposited at the dumping site, they created at least temporarily: 1) a high rate of oxygen depletion at the disposal site and in the surrounding area since there are local currents all year around; 2) a complete destruction of bottom-dwelling organisms at the disposal site since these were completely covered by sediments and could not continue their normal and vital respiratory processes; and 3) a

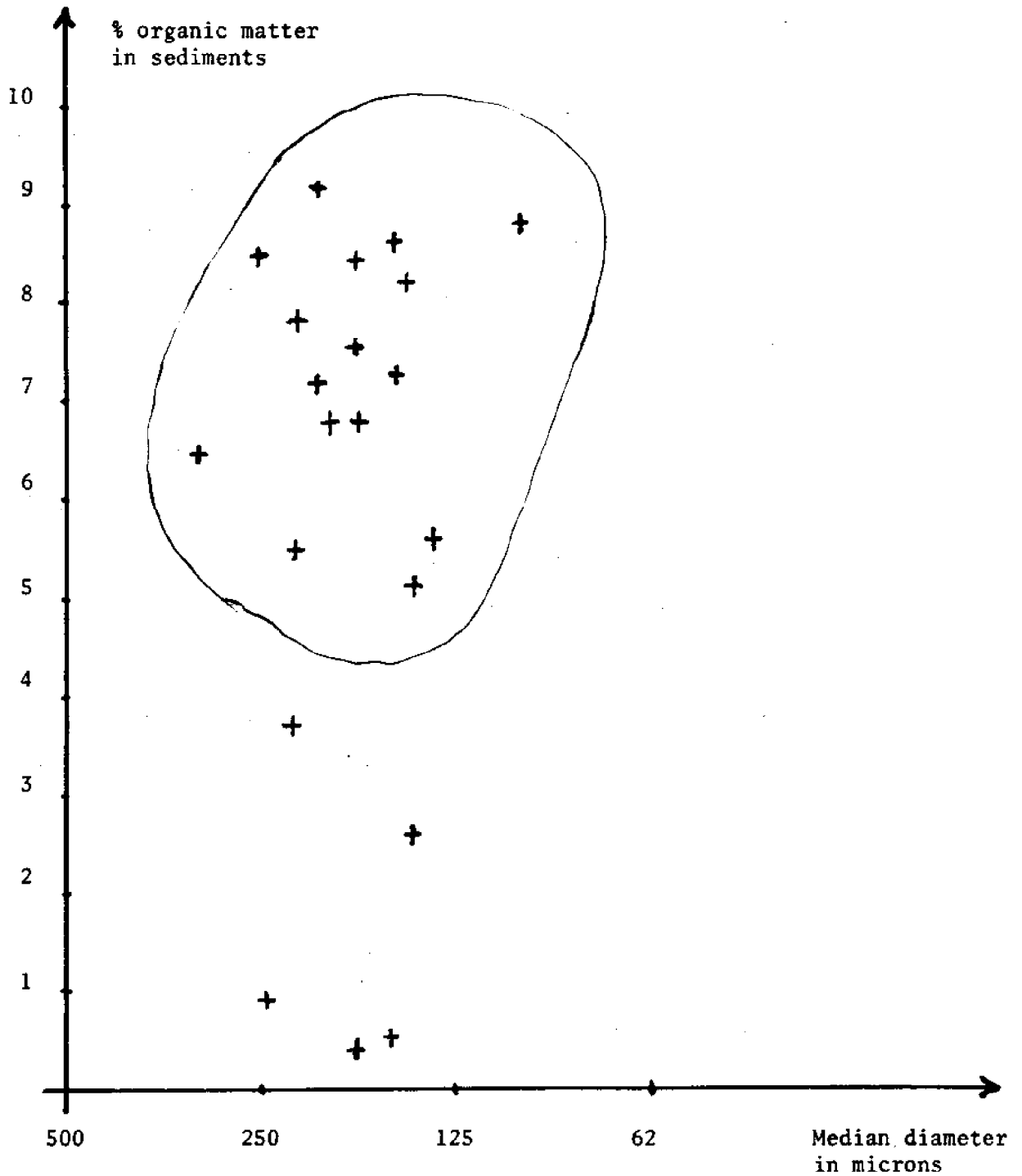

Figure 3. Comparison of grain-size and organic content for dredge spoil sediments.

probable destruction of some of the benthic organisms in areas surrounding the disposal site due to oxygen depletion as explained in 1) above.

Sediments at the Disposal Site Although they have evidently the same regional provenance, the sediments of the disposal site (Yancey 1968) differ from those of the dredge site in several of the measurable parameters. The median diameter for example, with a value of 0.143 mm is also in the fine sand range but is strongly skewed toward the very fine range. The sorting coefficient of most samples is excellent to good. It ranges from a low value of 1.16, an excellent sorting to 1.84 which still represents good sorting. The average sorting value 1.359, is much better than that of the dredging site due to wave action as the single most effective sorting agent in contrast to several sorting processes at the dredge site. Sediments at the disposal site had a good permeability prior to dumping operations and the interstitial waters undoubtedly were very well aerated with a large enough amount of oxygen for the rather abundant benthic life present in the immediate area. This well aerated zone extended 4 inches down in the sediments since many polychaete worms were found down to that depth. In addition the overlying waters supplied a large amount of food particles to support this abundant benthic life.

Rough Benthic Survey It was originally planned to have a team of divers conduct a rapid visual survey of benthic organisms present on the substratum along the profiles shown on the bottom topography

map (Figure 2). This survey had to be completed before the beginning of dredging operations which were scheduled to start in February 1971, hence the only possible months were December 1970 and January 1971. Repeated attempts by divers were unsuccessful due to the nearly nil visibility within 4 to 5 feet above the bottom. During periods of flow of the nearby San Lorenzo River a large amount of organic debris and silts forms a dense layer which prevented the divers from seeing the bottom even with a powerful underwater light. As a result, sampling was done by boat from the surface (Figure 4) using the same sampling device throughout the study. No replicate samples were taken due to lack of funds and time for a more extensive study. Each grab sample covered approximately one square foot of sediment surface.

Following are the biological data. All the stations for which the samples were sorted biologically, 33 altogether, are listed in Table I. For each station the number of Polychaetes, Echinoderms, Crustaceans, Molluscs and others have been tabulated (Table II). From the data sheets for each station a "pie-diagram" (Figure 5) was constructed showing the percentage of each of these groups in relation to the total number of organisms. Four stations: 4A, 15, 27 and 43 have samples of rocks or a rocky substratum, only station 15 did not have any organisms.

The general technique for sampling consisted of securing a bottom sample by means of a Peterson grab sampler using a 25 foot inboard motor boat equipped with a hydraulic winch. All stations were located by magnetic compass bearing and are situated as shown on Figure 4. Each sample was placed in a plastic bag along with a cup of 10% buffered formaldehyde, an organic dye (Rose Bengal) and an identification tag.

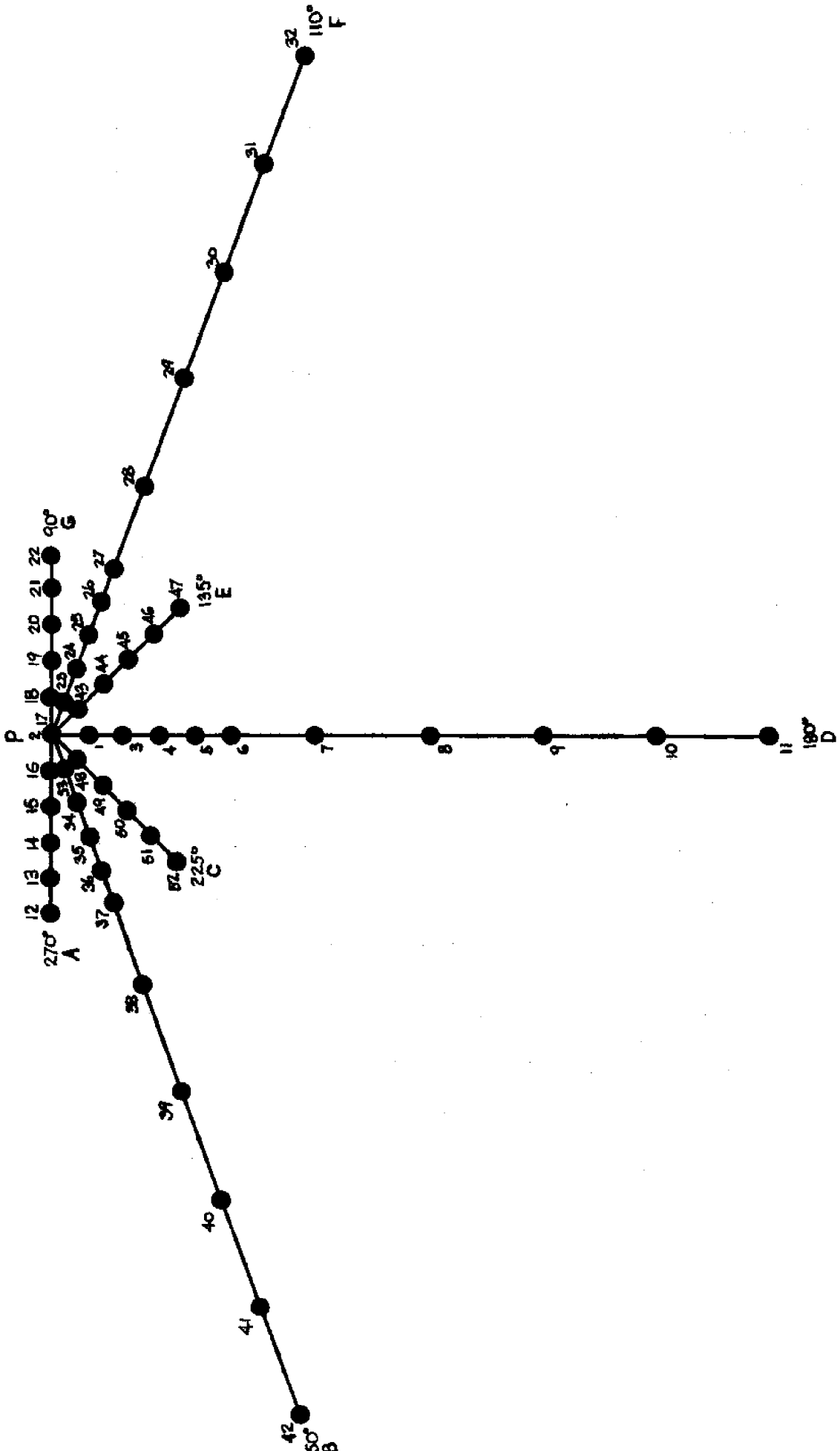

Figure 4. Location of each sampling station in relation to disposal site P. (expanded from figure 2)

For processing the samples in preparation for rough sorting, each sample was set aside in a 115 mesh sieve for a period of 5 to 7 minutes to allow the excess water to drain off; the sample was then weighed. Results are shown in grams in Table I.

After draining of excess water, the sample was then transferred to a 16 mesh sieve with a mesh opening of approximately 1 millimeter. This was done in order to remove the sediments and retain the organisms which were weighed separately. The results are expressed in grams and shown in Table I. All the organisms were finally placed in 70% isopropyl alcohol and later sorted to major groups and placed in vials as to group for possible study later. For each processed sample the biomass was calculated and is expressed in grams per square meter to follow the common practice. The average biomass value for the disposal site and immediate vicinity was calculated to be 227.5 g/m^2 . This is a high value for any area of the ocean floor, even for the near-shore environment. Table I, in addition to the biomass data, provides information on the weight percentage of organisms in the sediments and this can be used as an index of organic content for these sediments.

Summary In summary, two interesting results have been obtained from this very short study: 1) the very high organic content of sediments at the dredge site regardless of the size of the particles of sediments, and 2) the high biomass value at the disposal site and surrounding area.

TOTAL	POLYCHAETES	426	57.1%
	MOLLUSCS	190	25.5%
	CRUSTACEANS	62	8.3%
	ECHINODERMS	11	1.5%
	OTHER	56	7.5%

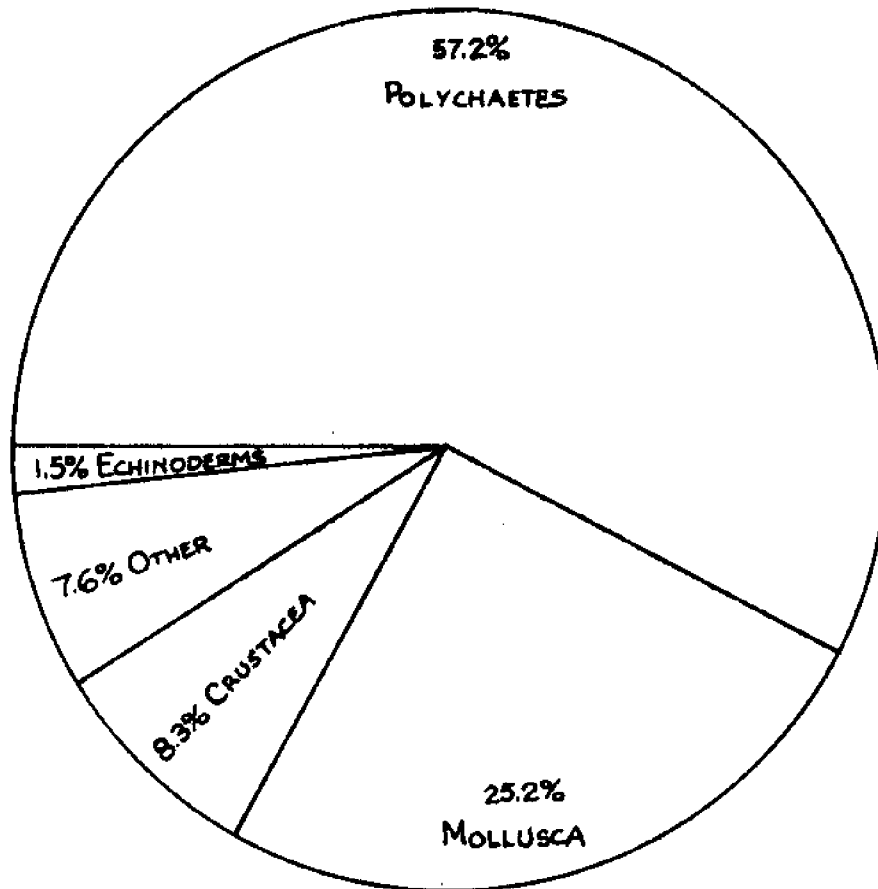

Figure 5. Pie Diagram showing proportion of major groups of benthic organisms

TABLE I Benthic Data for

STATION NUMBER	SAMPLE WEIGHT IN GRAMS	ANIMAL WEIGHT IN GRAMS	NUMBER OF SPECIMENS OF ORGANISMS	BIOMASS g/m ²	% ANIMAL WEIGHT SAMPLE WEIGHT IN GRAMS	ANIMAL NUMBER SAMPLE WEIGHT IN GRAMS
2	720	4.6	8			
4A	87	16.7	15			
5	625	25.9	14			
7	740	20.5	14			
8	562	25.4	14			
9	720	24.7	40			
10	554	61.3	6			
11	982	30.1	20			
13	840	17.0	53			
15	64.3	0 (rocky)	0			
18	754	20.4	33			
19	580	18.9	35			
20	567	17.7	30			
22	520	15.1	11			
23	630	37.0	18			
25	372	17.9	19			
27	9.5 (rocky)	1.5	4			
28	442	17.5	28			
29	895	9.4	22			
31	454	0	0			
32	205	24.7	10			
33	172	17.4	5			
35	923	Not weighed	11			
37	640	18.1	4			
38	694	13.5	91			
40	116	17.7	3			
42	461	49.9	49			
43	478	25.7	22			
45	1027	22.1	42			
47	874	15.9	77			
48	450	18.7	26			
50	716	42.5	37			
52	657	28.0	43			

33 Processed Samples

BIOMASS g/m ²	% ANIMAL WEIGHT SAMPLE WEIGHT IN GRAMS	RAATIO ANIMAL NUMBER SAMPLE WEIGHT IN GRAMS
51.1	0.64	.0111
185.5	19.20	.1724
287.7	4.14	.0224
227.7	2.77	.0189
282.1	4.52	.0249
274.4	3.43	.0556
681.0	11.96	.0108
334.4	3.07	.0204
188.8	2.02	.0631
0	0	0
226.6	2.71	.0438
209.9	3.26	.0603
196.6	3.12	.0529
167.7	2.90	.0212
411.0	5.87	.0286
198.8	4.81	.0511
16.6	15.79	.4211
194.4	3.96	.0063
104.4	1.05	.0246
0	0	0
274.4	12.05	.0488
193.3	10.12	.0291
0	Not available	.0119
201.0	2.83	.0063
149.9	1.95	.1311
196.6	15.26	.0259
554.3	10.82	.1063
285.5	5.38	.0460
245.5	2.15	.0409

TABLE II

Biological Data for 33 Processed Samples

STATION	<u>2</u>	<u>4A</u>	<u>5</u>	<u>7</u>	<u>8</u>	<u>9</u>	<u>10</u>	<u>11</u>	<u>13</u>	<u>15</u> rock	<u>18</u>	<u>19</u>
---------	----------	-----------	----------	----------	----------	----------	-----------	-----------	-----------	-------------------	-----------	-----------

P	1	5	9	10	11	29	4	13	22	0	14	9
---	---	---	---	----	----	----	---	----	----	---	----	---

E	0	0	1	0	0	0	0	0	0	0	2	0
---	---	---	---	---	---	---	---	---	---	---	---	---

C	2	1	1	0	1	1	0	0	5	0	1	3
---	---	---	---	---	---	---	---	---	---	---	---	---

16	21	0	13	15				M	1	6	3	0	1	10	2
----	----	---	----	----	--	--	--	---	---	---	---	---	---	----	---

1	0	0	3	5				0	2	3	0	4	0	0	0
---	---	---	---	---	--	--	--	---	---	---	---	---	---	---	---

<u>31</u>	<u>32</u>	<u>33</u>	<u>35</u>	<u>37</u>
-----------	-----------	-----------	-----------	-----------

0	3	5	9	4
---	---	---	---	---

0	2	0	0	0
---	---	---	---	---

0	1	0	0	0
---	---	---	---	---

0	2	0	0	0
---	---	---	---	---

0	2	0	2	0
---	---	---	---	---

STATION	<u>20</u>	<u>22</u>	<u>23</u>	<u>25</u>	<u>27</u>	<u>28</u>	<u>29</u>
---------	-----------	-----------	-----------	-----------	-----------	-----------	-----------

P	14	8	7	11	2	22	11
---	----	---	---	----	---	----	----

E	1	1	0	0	0	0	0
---	---	---	---	---	---	---	---

C	2	0	4	1	0	3	4
---	---	---	---	---	---	---	---

M	10	0	1	5	0	3	3
---	----	---	---	---	---	---	---

0	1	0	4	1	2	0	0
---	---	---	---	---	---	---	---

<u>50</u>	<u>52</u>
-----------	-----------

5	22
---	----

2	0
---	---

7	2
---	---

9	17
---	----

7	0
---	---

STATION	<u>38</u>	<u>40</u>	<u>42</u>	<u>43</u>	<u>45</u>	<u>47</u>	<u>48</u>
---------	-----------	-----------	-----------	-----------	-----------	-----------	-----------

P	47	2	9	12	22	57	7
---	----	---	---	----	----	----	---

E	0	0	1	0	0	0	1
---	---	---	---	---	---	---	---

C	0	1	14	1	1	2	4
---	---	---	----	---	---	---	---

M	23	0	6	7	7	14	5
---	----	---	---	---	---	----	---

0	1	0	6	1	11	3	3
---	---	---	---	---	----	---	---

P = Polychaetes

E = Echinoderms

C = Crustacea

M = Molluscs

0 = Other

A STUDY OF SEAWARD DIPPING INTERNAL STRUCTURES
IN MARINE RIPPLE MARKS AT WHALER'S COVE, CALIFORNIA

by

Lawrence C. Leopold
Sea Grant Research Assistant

1972

Moss Landing Marine Laboratories
of the
California State University
at
Fresno, Hayward, Sacramento, San Francisco, and San Jose

TABLE OF CONTENTS

	PAGE
ABSTRACT	24
INTRODUCTION	25
Acknowledgements	26
GENERAL FIELD WORK	26
1) Regional Geology	26
2) Channel Boundary Conditions	33
3) Channel Sediments	34
4) Sediment Ripple Marks	39
INTERPRETATION	44
1) Hydrodynamic Conditions	44
2) Internal Ripple Structures	45
3) Possible Causal Factors	48
CONCLUSION	52
APPENDIX	54
1) Basic Under Water Measuring Tools	54
2) Large Settling Tube	56
3) Mobile Wave Staff System	59
4) Submersible Current Meter	65
5) Box Core Sampling	69
REFERENCES	72

LIST OF FIGURES

FIGURE	PAGE
1 - Location map of Carmel Bay (from C & GS 5476).	27
2 - Surface outline map of Whaler's Cove, Point Lobos State Reserve, Carmel, California.	29
3 - Topographic map of the bottom of the entrance to Whaler's Cove.	30
4 - Vertical conglomerate wall, largest cobbles 15-18 cm.	32
5 - Coarsest lithic and bioclastic particles; scale is 2 cm long.	32
6 - Channel sediments from depth of 9.1 m, taken April 6, 1972; scale is 2 cm long.	37
7 - Channel sediments from depth of 12.4 m, taken April 6, 1972; scale is 2 cm long.	37

8 - Channel sediments from depth of 15.2 m, taken April 6, 1972; scale is 2 cm long. 38

8 - Channel
Apr

9 - Channel sediments from depth of 18.3 m, taken April 6, 1972; scale is 2 cm long. 38

9 - Chan
Apr

10 - Diver measuring ripple mark cord (wave-length) and height. 41

10 - Div
len

11 - Vertical view of diver measuring ripple marks, straight crest lines. 41

11 - Ver
not

12 - Inclined goniometer measuring slope of ripple mark. 43

12 - Inc

13 - Section of chart record from submersible and current meter. 43

13 - Sec
duc

14 - Diagrams of Box Core Sampling Technique. 46

14 - Det

15 - Photograph of 9 m deep sample taken January 1972. Original orientation marked. 47

15 - Rad
197

FIGURE	PAGE
16 - Radiograph of 20 m deep sample taken January 1972. Original orientation marked.	47
17 - Radiograph of 18.3 m deep sample, taken April 6, 1972. Original orientation marked.	49
18 - Radiograph of 15.2 m deep sample, taken April 6, 1972. Original orientation marked.	49
19 - Radiograph of 12.4 m deep sample, taken April 6, 1972. Original orientation marked.	50
20 - Introduction doors of large settling tube, doors in open, uncocked position.	50
21 - Details of large settling tube used for hydraulic size analysis.	57
22 - Mobile wave staff system.	62
23 - Submersible current meter system shown as oriented and assembled.	66

LIST OF TABLES

Size Analysis by Large Settling Tube	39
--	----

ABSTRACT

Experiments were conducted to test whether structures within large scale ripple marks, 8-21 m deep, when built under the influence of shoaling waves, dipped shoreward. Previous work has demonstrated the above relationship to hold in water 1-4 m deep. SCUBA divers using the Senckenberg box core technique sampled large scale ripple marks composed of coarse grain, highly bioclastic, unconsolidated sediments. The sampling site was an elongate channel-like body in the entrance of Whaler's Cove, Point Lobos State Reserve, near Carmel, California.

The internal structures recovered were found to be dipping away from the shoreline. This was a surprise since the major building agent for the ripple marks is the oscillatory motion induced by shoaling waves. Perhaps the slope of the channel bottom, $3-4^{\circ}$ to seaward, is the cause of the unexpected seaward dip of the internal structures. Therefore, caution must be exercised when using the direction of dip within preserved bed forms to indicate the location of the paleoshoreline.

A section on the special equipment and techniques developed to conduct this study is contained in the Appendix to this paper.

INTRODUCTION

Field experiments were conducted to test certain specific statements about the behavioral response of unconsolidated sediments to shoaling wave patterns. The following quote is from Newton (1968, p. 281-283). It is the last sentence which is of particular relevance to this study.

Wave-formed ripples, whether symmetrical or asymmetrical, exhibit an unidirectional internal lamination dipping normal to the strike of the ripple crests - usually shoreward.

es-alone-are responsible for ripples... the stronger positive (normally...) component of oscillation controls... ternal structure. Although this cons- s based on samples from relatively ater, the water depths included the tween rippled and unrippled sand where e just beginning to "feel bottom". his border is in a water depth of 1.5 m l waves or 20 m from large waves, the ripple structures must be similar.

ement from Clifton, Hunter, and Phillips emphasizes the same expected relationship of to external form. "Internal structure of ble facies consists of shoreward inclined tion . . . The lunate megaripples produce rd dipping foresets."

test the above conclusions was conducted along urally occurring channel-like body. Depth anges from 8 m at the shallow end to 21 m at horizontal distance of about 200 m. The in the mouth of Whaler's Cove, Point Lobos State

where wa generati shorewar ripple clusion shallow border l waves w Whether from sma resultan

A similar sta (1971, p. 651) re internal structure the asymmetric rip ripple cross-lamin medium-scale land

The project the bottom of a n along the channel the deep end over channel is locate

Reserve, at the Southeastern end of Carmel Bay (Fig. 1). This is a submerged channel with presently active sediment entrainment. All field sampling was done with the aid of SCUBA equipment.

Acknowledgements

The following individuals: Dr. R. S. Andrews, T. Boverman, Dr. H. E. Clifton, R. Graf, Lt. B. F. Howell, J. F. Leopold, and L. R. Phillips, graciously contributed direct field assistance and support. An inestimable amount of field support and personal assistance was received from the fellow workers and activities of Beta Research Oceanographic Laboratories. Dr. W. P. Dillon is recognized for his ongoing inventive counsel and aid. Dr. H. E. Clifton is also thanked for his critical commentary of this paper. In addition to his comments and contributions to this paper, the long term guidance and assistance of Dr. Robert E. Arnal are gratefully acknowledged. Much of the work was completed with support from the National Sea Grant Program, Grant No. 2-35137, at Moss Landing Marine Laboratories.

GENERAL FIELD WORK

1) Regional Geology

A complete review of the geology of the Carmel Bay area may be found in a paper by Simpson (1972), a Naval Postgraduate School Thesis

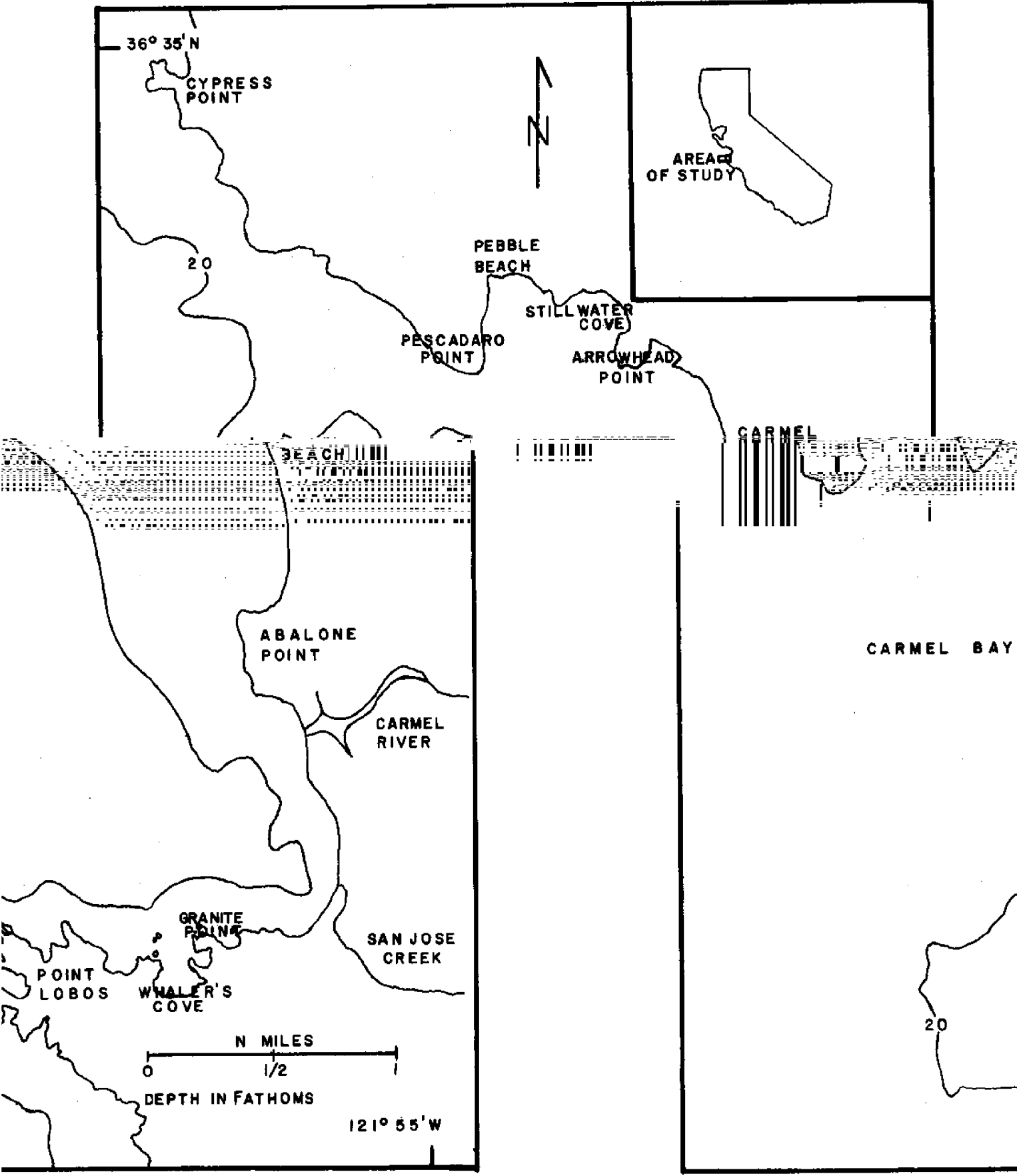

Bay (from C & GS 5476).

Figure 1 - Location map of Carmel

entitled, "The Geology of Carmel Bay, California."

Carmel Bay, situated on the Central California coast (fig. 1), is an embayment cut by the Carmel Submarine Canyon (a principle tributary of the Monterey Submarine Canyon to the north). The head of Carmel Canyon is located close to the beach in the southeastern sector of the bay.

Carmel Bay is protected to the north and south by Cypress Point and Point Lobos, both of which are composed of Cretaceous Santa Lucia granodiorite. Granite Point, Pescadero Point, and the southern half of Abalone Point are also made up of granodiorite. Arrowhead Point and the northern side of Abalone Point are made up of Miocene volcanics.

Carmel Beach, Pebble Beach, Stillwater Cove, and Whaler's Cove have been formed by weathering of Paleocene Carmelo pebble conglomerate. (Zardeskas, 1971, p. 11).

A more specific study of the subaerial geology of Whaler's Cove, as part of Point Lobos State Reserve, is described by Nili-Esfahani (1965).

The headlands on both the east and west sides of the mouth

of Whaler's Cove are Santa Lucia granodiorite

heads that are

on, (Nili-

pression of this

forms the southern

melo cobble con-

rs the topography

surface geology

re developed from

nographic

are pebbly mudstones and pebble conglomerate

characteristic of the Paleocene Carmelo Forma

Esfahani, 1965). Figure 2 shows the surface

contact at Whaler's Cove. The peninsula which

side of the mouth of Coal Chute Cove is all C

glomerate.

Figure 3, the inset area on Figure 2, sho

for the central and western portions of the s

in the mouth of Whaler's Cove. The contours w

bathymetric data supplied by Beta Research Oce

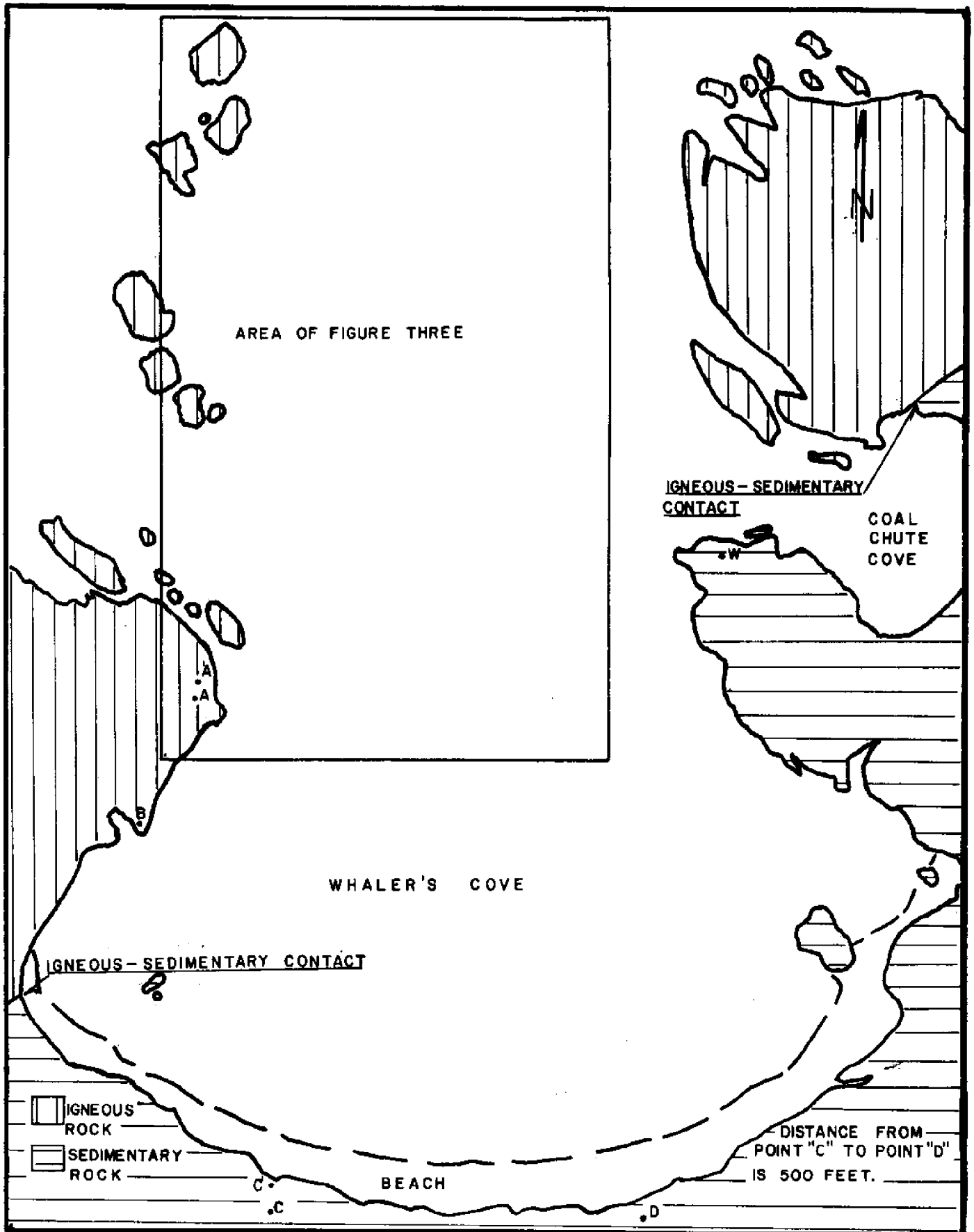
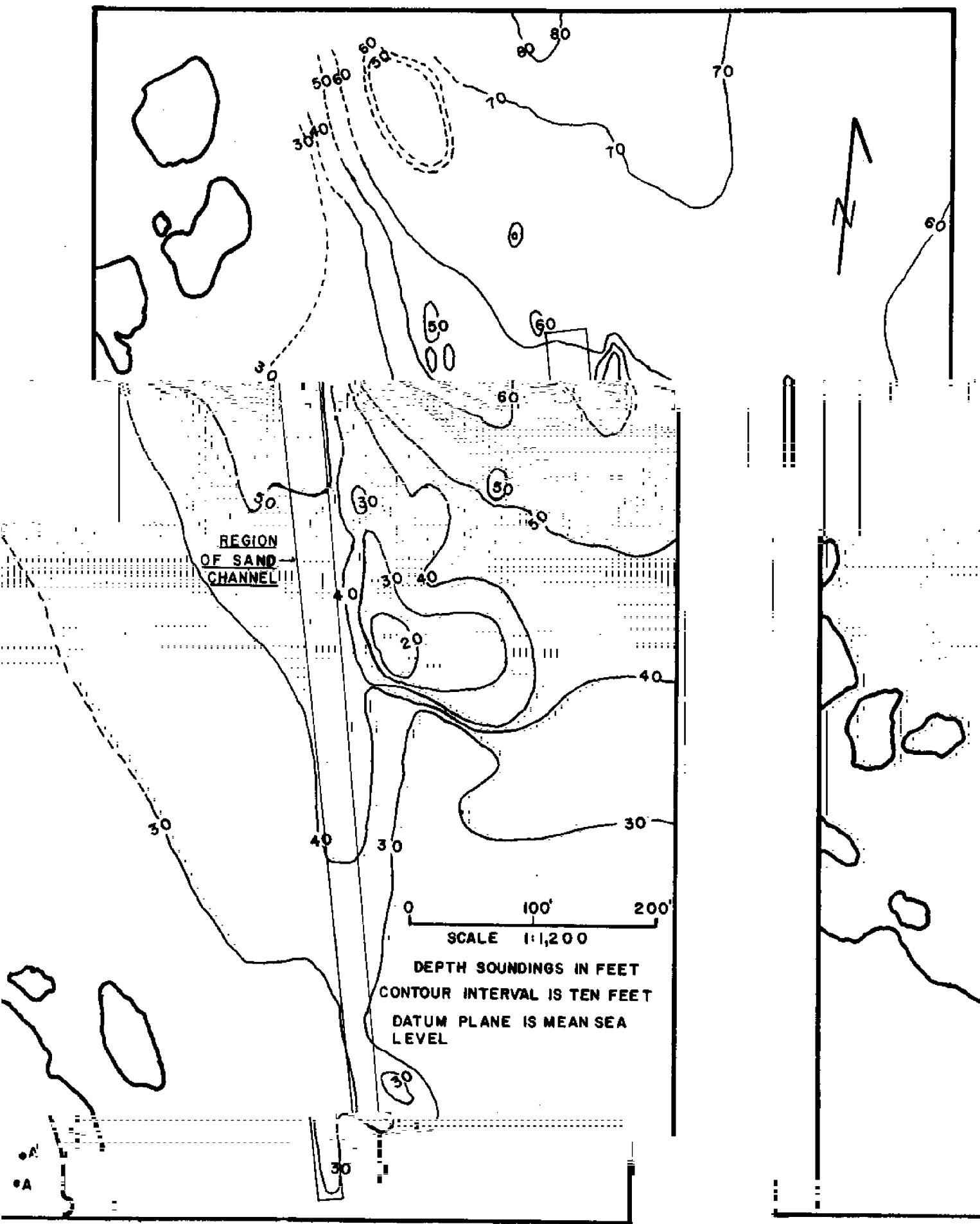

Figure 2 - Surface outline map of Whaler's Cove, Point Lobos State Reserve, Carmel, California.



map of the bottom of the entrance to Whaler's Cove

Figure 3 - Topograph

Laboratories. The datum plane is corrected to mean sea level. This was done because the best available base map of Whaler's Cove (1933) has its datum plane at average sea level.

Bathymetric values were obtained from readings of a Heathkit Model 1-11 fathometer operated from a small craft. Position fixing for depth profiles was done by means of a coordinated system of transits at fixed points on the perimeter of Whaler's Cove. These points (A, A', B, C, C', D, and W on Fig. 2) are concrete markers implanted in the ground. The data supplied by Beta Research is the best available for the area at this time.

Final contour sheet was constructed from a smooth sheet of over 300 datum points. Final contour lines were further refined by taking into account the results of observations of the subsurface structures made while diving during the past two years.

Figure 3 clearly shows the expression of an elongate topographic high, of north-south orientation. At no time is this body, located centrally in the mouth of Whaler's Cove, above sea level (Fig. 2). Underwater photographs (Fig. 4) and hand samples have been taken from this submerged body. These samples are lithologically similar to the cobble conglomerate beds of the Carmelo Formation on the eastern and southeastern shores of Whaler's Cove.

SCUBA-aided reconnaissance surveys have shown that the conglomerate is an unbroken continuation from the southern side of Coal Chute Cove. Presently the northern-most extension of the conglomerate in the mouth of Whaler's Cove has been seen to terminate in 20-21 m of water. Thus this body now underwater,



Figure 4 - Vertical section of conglomerate wall, largest cobbles 15-18 cm:



Figure 5 - Coarsest lithic and bioclastic particles; scale is 2 cm long.

extends significantly north of the northeast to southwest trending line of contact of the Santa Lucia granodiorite-Carmelo Formation in Whaler's Cove as proposed by Nili-Esfahani, (1965, p. 16).

2) Channel Boundary Conditions

The submerged conglomerate body is the defining eastern edge of the elongate continuum or coarse, unconsolidated sediments that are the object of this study. Having an almost straight axis, the channel strikes approximately N13^oW. It is approximately 200 m long. At its shallow, southern end the channel is 8 m deep; at its deeper, northern end, the channel is 21 m deep. Once north of the northern tip of the conglomerate body, the channel ceases to be defined. Average slope of the bottom taken over the whole length of the channel is 3^o45'. However, the slope is not constant and tends to have two distinct sectors. From the 10 to 15 m depths the slope varies from 2^o30' to 3^o30', while from the 15 to 21 m depths the slope is 4^o to 5^o.

The break in slope indicated on the contour map is supported by the observations taken during survey swims along the whole length of the channel. Observations of the author have been confirmed by post-dive debriefings with other diving geology students (personal communications with Bob Graf, Tim Boverman, and Mike Sims). All divers noted, when passing over the 15 m depth (if swimming north to south), that they were swimming up a more gentle grade after that point. Width of the channel tends to remain fairly constant at 6 to 8 m. Only when south of the 11 m depth does the channel narrow to 2 to 3 m (Fig. 3).

3) Channel Sediments

There are several main source regions for the materials that comprise the sediments in the channel. The southern edge of Whaler's Cove, with cliff faces 5 to 6 m high, is continually being undercut and eroded by wave action. This edge of the cove is predominantly sandstones, siltstones and shales of the Carmelo Formation with some pebbly mudstonesbeds.

The sandstones may appear as thick beds, may be included as lenses in the conglomerate, or can occur as thin layers alternating with the siltstones and shales. The shale is dark due to an abundance of carbonaceous materials. The siltstones are usually light and are commonly found alternating with layers of shale.

Under a microscope the Carmelo sandstone is not easily identified. The rock is as much as 50% feldspar, the rest being quartz with an occasional lens of twisted biotite. Individual fragments are extremely angular and fresh in appearance. The matrix covers 5 to 10% of the total area of slide and is composed almost entirely of silt and clay. Some samples show slight effervescence when treated with dilute HCL (Simpson, 1972, p. 28).

Due to the position of the submerged conglomerate body, probably little or no sediments are contributed to the channel from the east central perimeter of Whaler's Cove (Coal Chute Cove area) (Fig. 2-3).

The headlands around Point A (Fig. 2) and the pinnacles north of Point A, which define the western side of the mouth of Whaler's Cove, represent exposures of Santa Lucia granodiorite. The following description is from Simpson (1972, p. 25).

The groundmass of the rock is extremely coarse and granular and consists primarily of quartz, whitish to greenish-white feldspar, and biotite. The quartz is best developed of the groundmass minerals, ranging in size to as much as 2 cm in diameter.

Next smaller in size are the areas of feldspar. The biotite measures from 1 to 2 mm. The feldspar is primarily oligoclase-andesine with a small proportion of orthoclase. The biotite is black, lustrous and contributes significantly to the appearance of the rock.

The phenocrysts, consisting of large crystals of glassy orthoclase, are the most obvious features of the granodiorite. They are usually twinned (Carlsbad Law) and elongated. The average grain diameter is 4 to 5 cm.

Simpson (1972) also noted the presence of minute cracks throughout the groundmass which "make the rock quite susceptible to disintegration". This disintegration of the pinnacles and western headlands is greatly accelerated by surf action of swells from the open Pacific Ocean. This mechanical erosion is effective enough to produce chemically unaltered lithic fragments 4 to 5 mm along their greatest axis (Fig. 5).

Three major sources contributing particles to the channel sediments are below water most or all of the time. First, there are the granodiorite headlands and pinnacles that are at and below sea level. They are constantly affected by the surging pressures of the swells.

The second submerged source is the elongate conglomerate body. Well rounded porphyritic pebbles and cobbles, usually 3 to 15 cm in diameter (Fig. 4), are the clasts in this body. For a complete description of these clasts see page 31 of Nili-Esfahani (1965). Matrix material of the conglomerate is well cemented feldspar and quartz grains of coarse sand size, approximately 1 mm in diameter. Pockets of clasts accumulated about the base of the body have been seen. This would indicate that the

matrix material is also available to the channel sediments.

Third, bioclastic material is a major component of the sediments. Bioclastic is used here as a collective term to include the whole, broken and/or abraded remains of the encrusting coralline algae and the profuse invertebrate faunal biomass. For complete statements of the plants and animals of this region see the 18 Month and 30 Month Survey Reports made available by Beta Research Oceanographic Laboratories (Nichols, 1970 and 1971). The largest single bioclastic piece found was a complete abalone shell 20 cm in diameter, whereas the smallest are abraded particles less than 62 microns in size.

A study of Graf (1971) indicates that bioclastic and calcareous material, as a percent-by-weight of a total sample, increases significantly as a function of position (increasing depth) along the channel. The increase ranges from 2.6% at 10 m to 71% at 15 m. This study shows also that the mean diameter of the inorganic fraction, the bioclastics having been dissolved by HCL, decreases gradually with increasing depth. Figures 6 through 9 illustrate such trends quite clearly. Each sample was taken from what had been the very top of the sedimentary column in a set of box cores (Appendix of Techniques). The set of samples were all collected within a half-hour period on April 6, 1972.

An oversized settling tube (Appendix of Techniques) was used to obtain a qualitative and quantified description of the hydraulic size equivalents of the sediments studied. Using each particle's individual fall velocity through a column of water to effect sorting, a definite pattern of coarse material shallow, and finer material deeper in the

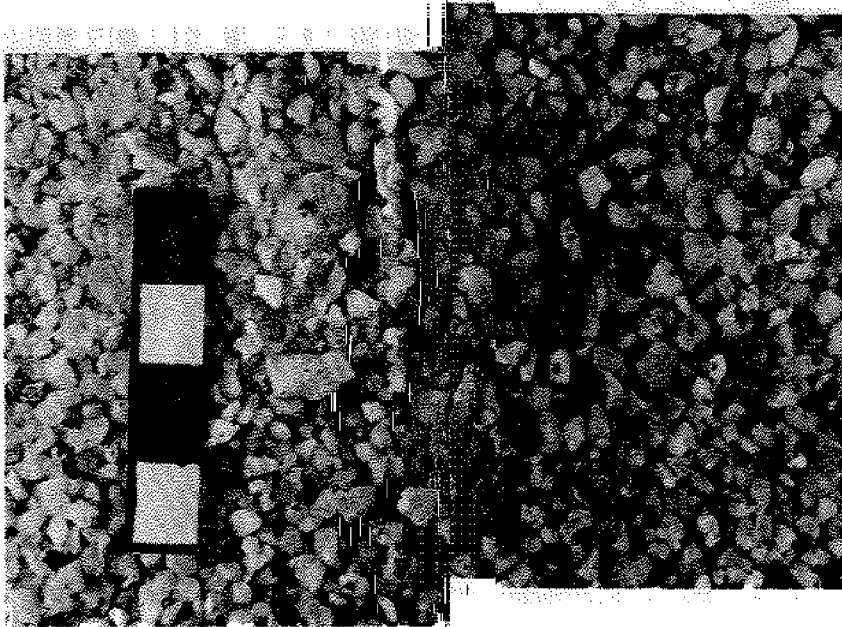

Figure 6 - Channel sediments from a depth of 9.1 m, taken April 6, 1972; scale bar is 2 cm long.



Figure 7 - Channel sediments from a depth of 12.4 m, taken April 6, 1972; scale bar is 2 cm long.

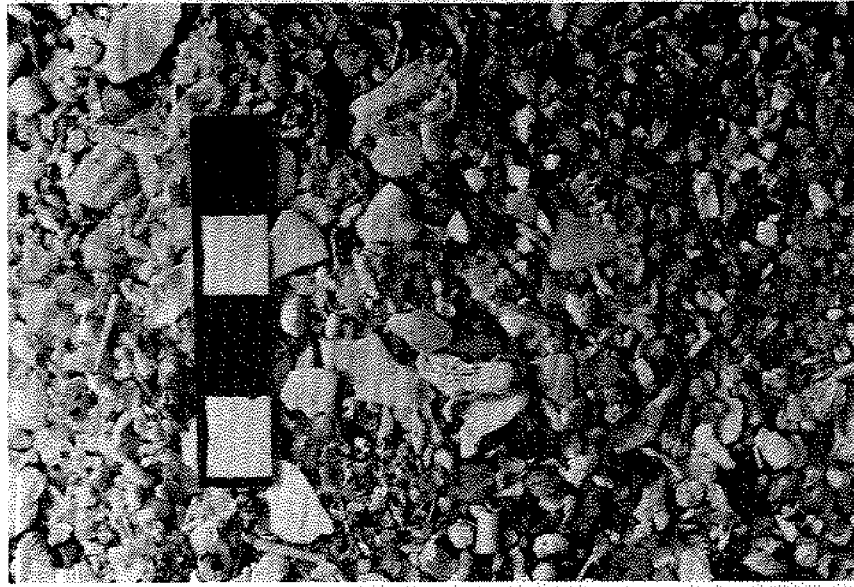

Figure 8 - Channel sediments from depth of 15.2 m, taken April 6, 1972; scale is 2 cm long.

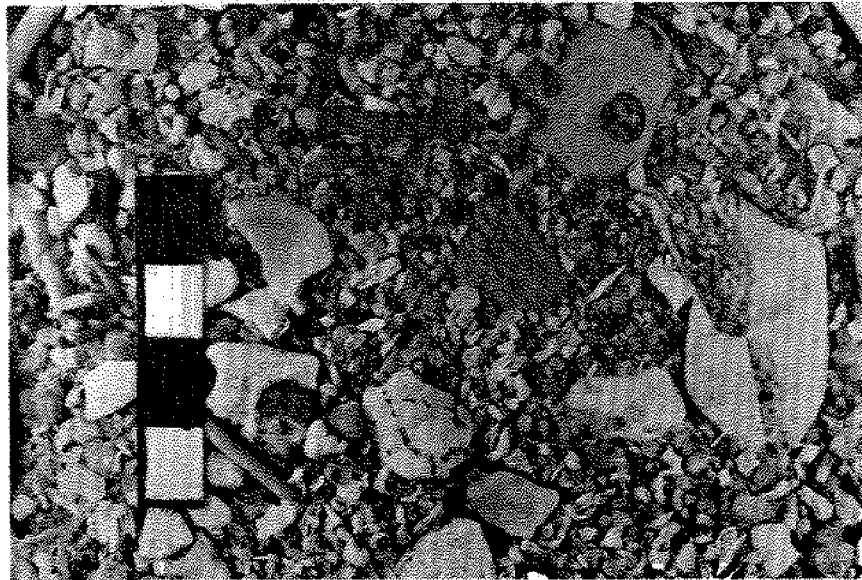

Figure 9 - Channel sediments from depth of 18.3 m, taken April 6, 1972; scale is 2 cm long.

channel was found (Table 1). While Table 1 demonstrates that the deeper samples have a significantly larger percentage of the finer fraction, all samples had some of the 5 to 6 mm lithic fragments. Presently, it is not known whether these larger fragments represent south to north net transport along the channel or west to east movement from the pinnacles.

Table 1. - Size Analysis by Large Settling Tube

Sample Depth in Meters	Time Interval in Seconds	Fractional Percent
18.3	0-15	29.4
	15-30	65.8
	30-60	4.7
15.2	0-15	41.0
	15-30	55.0
	30-60	3.8
12.4	0-15	68.0
	15-30	28.0
	30-60	3.8
9.1	0-15	80.0
	15-30	19.0
	30-60	1.0

Largest grains fall fastest. Note trend from finer to
 coarsest as change from deep to shallow samples. Each sample
 was repeated 5 times.

4) - Sediment - Ripple - Marks

It is along the linear body of coarse sediments that the ripple forms were field tested.

"By ripple mark we understand all of those bed forms of loose-grain boundaries that are found as assemblages of similar individuals of intermediate physical scale and arranged transversely to flow. Ripple mark, then, covers both the symmetrical and near symmetrical structures formed by oscillatory water waves and, dealt with in this book the strongly asymmetrical structures generated by unidirectional flows of which only one component is effective (Allen, 1968, p. 36)."

The descriptive terminology of ripple marks of Allen (1968, p. 60-63) is used in this paper to provide the best possible continuity with other authors (Fig. 10).

Large scale refers to ripple marks with chords exceeding 60 cm and heights exceeding 4 cm. During the period of field work, heights measured (Appendix of Techniques) were never less than 8-9 cm, and ranged to a maximum of 32 cm. While some chord lengths were as

small as 50 cm, the majority were 80-100 cm with some exceeding 145 cm.

The ripple marks in this channel are within the defining limits of the megaripples of Clifton et al. (1971, p. 658); chords 0.5-1.5 m and heights 30-100 cm. Figures 10 and 11 illustrate the measuring techniques used and provide a sense of scale. Figure 11 also helps to illustrate that the ripples are essentially Plane Straight Type 1 type ripples having their crestlines rectilinear in plane view.

The use of the terms stoss side and leeside is specifically avoided in this paper. These terms indicate that a directional water mass displacement is known. Such flow patterns have not

been identified in the study area. Instead the terms north-south dipping will be applied to the slope sides. The strike of the channel is N13°W. 80% of all strike-of-ripple-crest

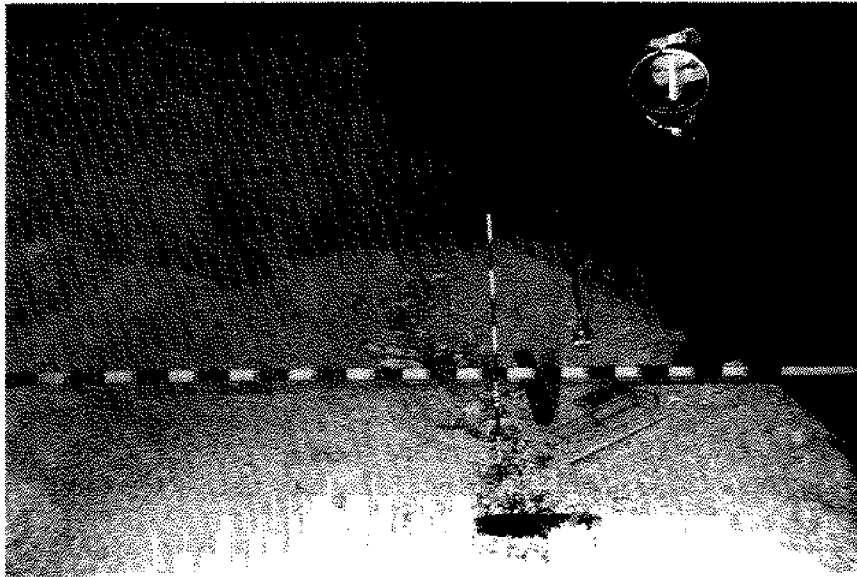

Figure 10 - Diver measuring ripple mark chord (wavelength) and height.



Figure 11 - Vertical view of diver measuring ripple marks, note straight crest lines.

fall between $N77^{\circ}E$ and $N80^{\circ}E$. The other 20% varied no more than 10° from the average value observed. The crestlines of the ripples are essentially perpendicular to the axis of the channel. Thus, the north dipping or south dipping slope properly identifies repeated and useful parameters in this particular region.

Values of the inclination from the horizontal (Fig. 12) of the ripple mark slopes have been measured over a period from June, 1970 through May, 1972. The north dipping face has usually been 4 to 5° steeper than the south dipping face. The maximum dip observed was $35^{\circ}N$. Only 3 times, during February and March, 1972, have symmetrical dips been observed. These equal values were in 9-12 m of water at the

~~shallow end of the channel. At no time however, was the south-~~
 dipping faces been observed to be steeper than the north dipping face

on the same ripple form.

Within the 13-21 m depth range the north dipping face normally ranges between 26° and 32° while the south dipping face normally varies between 22° and 27° . When apparently equal values were found, in the shallower depths, the dip values varied from 20° to 25° . On April 8, 1972, in the 17 to 21 m depth range, north dipping slopes were found to be 10° steeper than the south dipping slopes, $25^{\circ}N$ and $15^{\circ}S$.

Energy to build these ripples has come from oscillatory surge action. Divers have repeatedly observed entrained sediments pluming from the crestlines of ripple marks. This pluming action has always been observed to completely reverse direction with each reversed stroke of the water mass. Personal observations leave no doubt that there are periods when threshold velocities required for bed load movement of

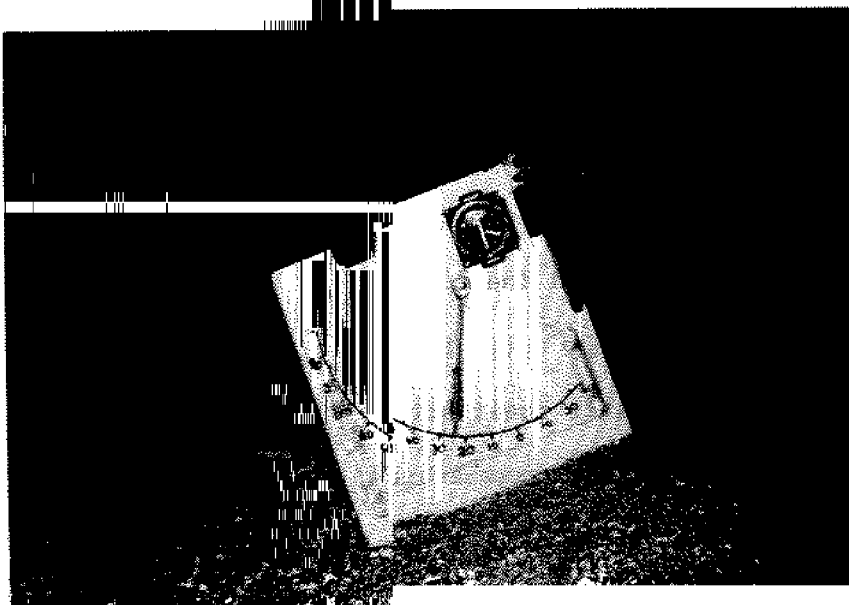

Figure 12 - Inclinometer measuring slope of ripple mark.

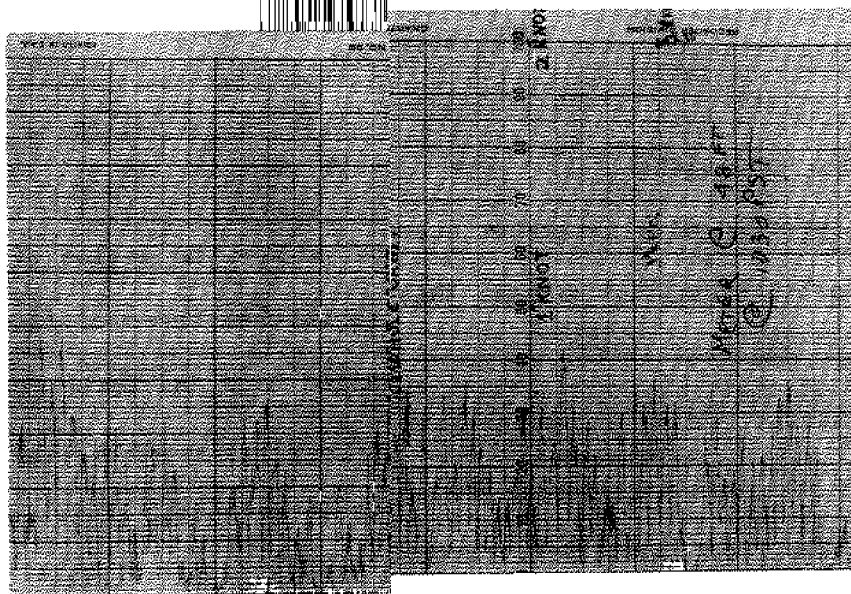

Figure 13 - Section of chart record from submersible current meter.

all available sediment exist to depths of at least 25 m.

During research dives in January, 1972, and again in February, 1972, previously unobserved conditions were found. The ripple marks were seen to have very rounded indistinct crestlines. Starfish and gastropod trails crossed and recrossed the top of each ripple mark. The forms observed were essentially relic forms having been built during some previous period of greater swell activity, possibly 2 to 5 days prior to the sightings (personal communication with Dr. H. E. Clifton). This degradation of the shape of the ripples due to action of benthic organisms was found along the whole length of the channel during the dives noted.

INTERPRETATION

1) Hydrodynamic Conditions

The first specific wave parameter quantified was the period of the swell-induced-orbit along the bottom. Divers watched the oscillatory paths of organic detritus as the material surged back and forth just above the sediments. Using the sweep hand of a diver's watch, the orbits measured had periods ranging from 9 to 16 seconds. Such observations were taken from June, 1970, through March, 1972. Orbital periods shorter than 9 seconds were not seen while some intervals as great as 18 seconds were recorded. These extremely long intervals may represent destructive interference in the wave spectra rather than exceptionally long period swells.

In April, 1972, the directional submersible ducted current meter system (Appendix of Techniques) was deployed. This system provided a direct graphic record showing that the greatest portion of orbital periods ranged from 12 to 15 seconds (Fig. 13). Neuman and Pierson (1965, p. 276) state that surface wavelength of a swell is approximately equal to $1.56T^2m$, T is the time of one wave period and m is the length of the wavelength in meters. The recorded periods indicate wavelengths of 225 to 351 m while the waves were traveling in deep water.

According to Inman (in Shepard, 1963, p. 67), a wave traveling in deep water first begins to feel bottom when the depth is equal to approximately one-quarter of its deep water wavelength. Since the period, T, of a swell remains constant as the swell moves from deep water to shallow water, the available swells can affect the sediments along the whole length of the channel. Thus it seems quite proper to state that the ripple marks are responding to the influence of shoaling wave patterns.

2) Internal Ripple Structure

The first set of box cores were taken in January, 1972. See

Figure 14 for orientation of casting device on the ground.

After processing as described in the Appendix, radiographs of castings from the 9 m

described in the Appendix, radiographs

deep and 20 m deep box core samples

9 m deep sample shows internal

radiographs of castings from the 9 m
 samples were made. Figure 15 of the
 structure dipping to the south as

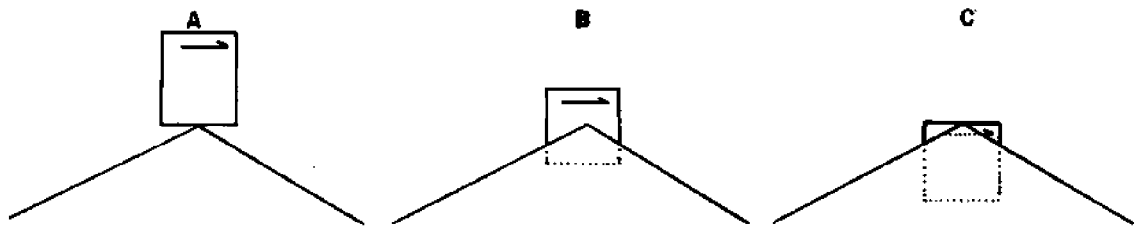

SEQUENCE SHOWING BOX CORE SAMPLING OF RIPPLE FORM

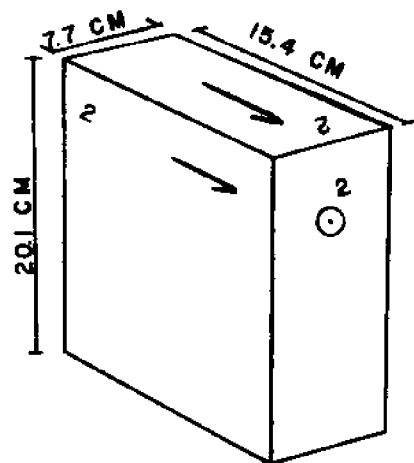

BOX CORE SHOWING SCALE and ORIENTATION MARKINGS

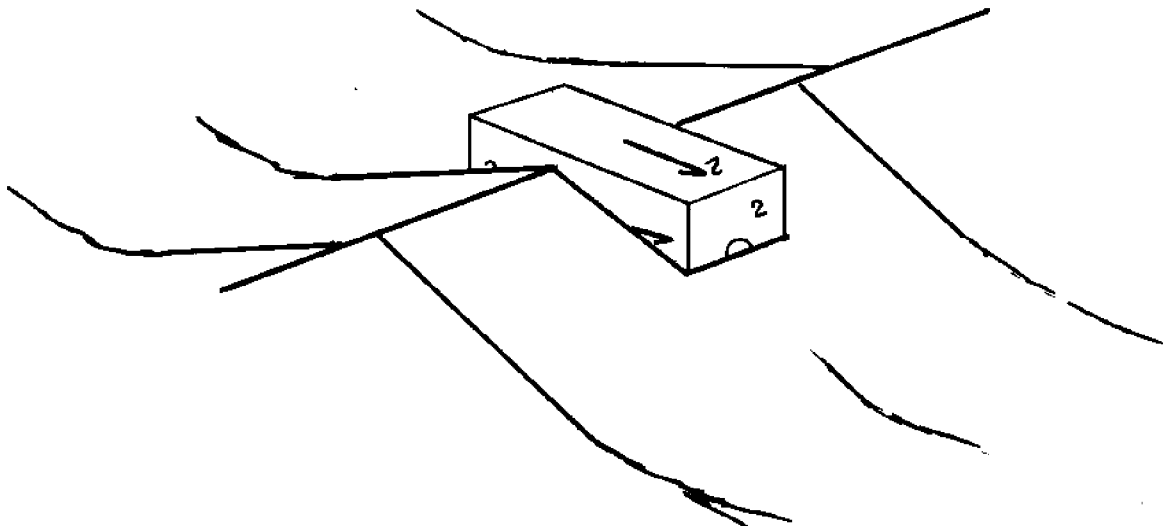

BOX CORE SAMPLE ACROSS CRESTLINE OF A RIPPLE MARK

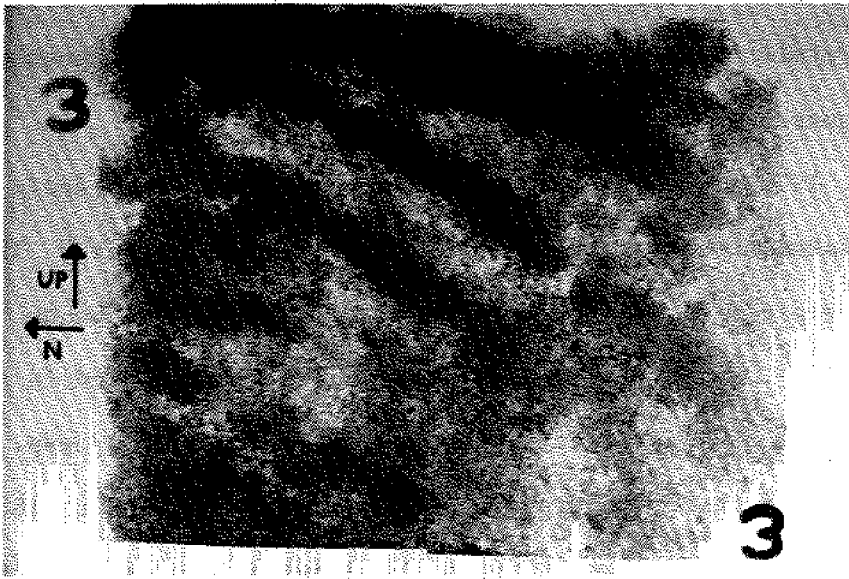

Figure 15 - Radiograph of 9 m deep sample taken January, 1972. Original orientation marked.

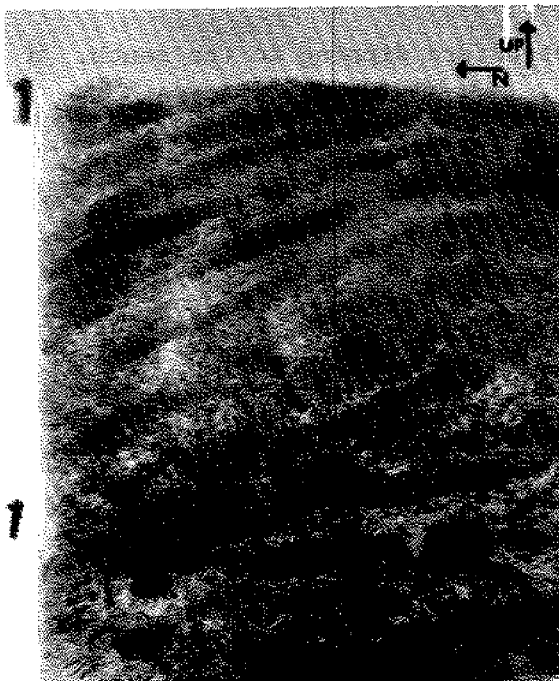

Figure 16 - Radiograph of 20 m deep sample taken January, 1972. Original orientation marked.

expected (north pointing arrow in picture). However, Figure 16, of the 20 m deep sample, shows internal structure dipping to the north. This is a completely unexpected pattern and contrary to the expected relationships quoted in the beginning of this paper.

On April 6, 1972, four more box core samples were taken. Again each core was taken straddling the crestline of the ripple mark. The depth of each sample was originally recorded in feet, the sequence being 60', 50', 40', and 30'. However, the depths are reported in meters for the sake of consistency. Figure 17, sample 18.3 m deep, shows very gentle northerly dipping internal structures. Figure 18, sample from 15.2 m depth, shows strong north dipping internal structures. The sample from 12.4 m, Figure 19, also shows internal layering dipping to the north. The cast from the 9.1 m deep sample had such irregular thicknesses, that no successful radiograph of it was possible. Visual inspection of the 9.1 m deep sample showed structure and scale similar to Figure 15, internal structure dipping to the south. A complete repetition of the April 6th, 1972, operation was conducted on May 6, 1972. Results of the second set of casts showed the same relationship of internal structure with depth along the channel.

3) Possible Causal Factors

Probably the single most significant difference between this study and those of Newton (1968) and Clifton et al (1971), is the overall slope of the bottom. In Newton's study area the nearshore zone is flat. In the study area of Clifton et al the region of megaripples is

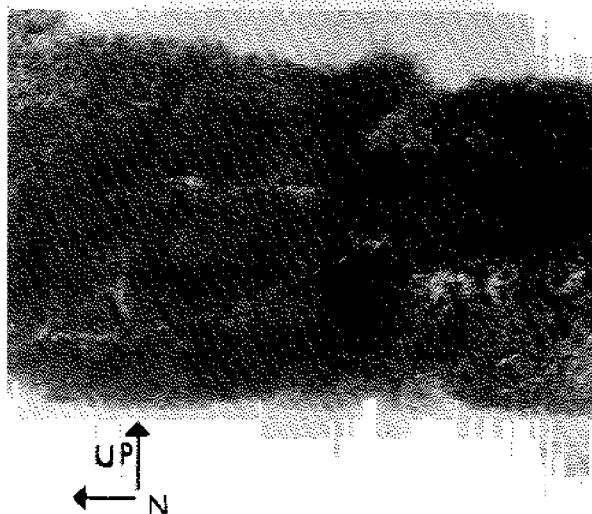

Figure 17 - Radiograph of 18.3 m deep sample, taken April 6, 1972. Original orientation marked.

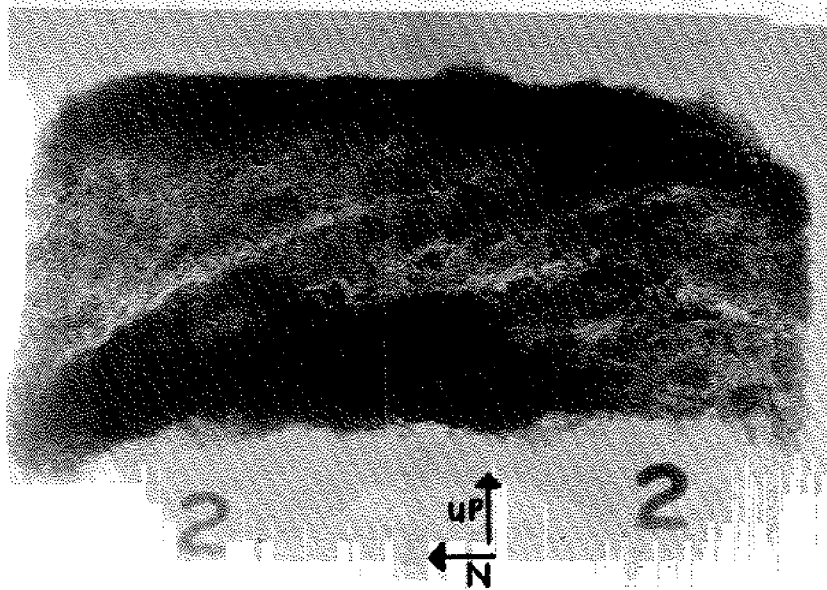

Figure 18 - Radiograph of 15.2 m deep sample, taken April 6, 1972. Original orientation marked.

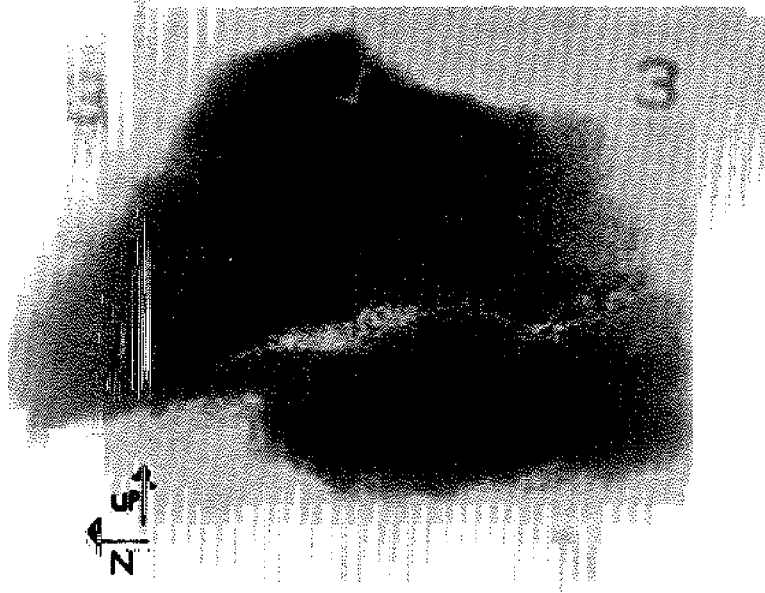

Figure 19 - Radiograph of 12.4 m deep sample, taken April 6, 1972. Original orientation marked.

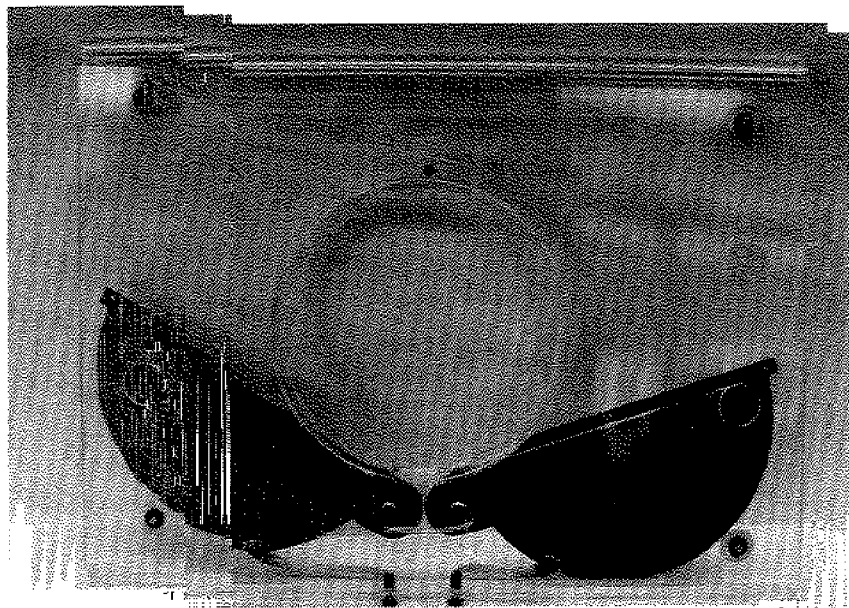

Figure 20 - Introduction doors of large settling tube, doors in open, uncocked position.

a "gently sloping bottom." A review of Figure 15 in their paper (Clifton et al., 1971, p. 661) indicates a slope of less than 1° dipping seaward. Depth by itself should not be a restructuring factor as long as the waves are of sufficient magnitude to strongly affect the bottom sediments.

The channel-like boundary conditions probably have little or no influence on the results. If anything, the channel helps to dampen out the influence of waves approaching the beach with fronts other than parallel to the shore and to the crestlines of ripple marks.

There is no fresh water entering Whaler's Cove other than from storm runoff. Therefore, there are only two factors which might generate a unidirectional flow along the bottom. First, there might be a weak net surface transport of water into Whaler's Cove driven by prevailing wind and swell action. Traveling from northwest to southeast, this surface water would come into the eastern side of the Cove, turn clockwise in the inner cove, and possibly induce flow out through the channel. There is an objection to this: the less dense surface water would need to be forced relatively deep in order to have a significant effect on bed load transport. A vertical series of flow meters would need to be deployed in order to adequately test for such distinctly layered water mass movements.

~~The second, and more likely factor, would be tidally induced~~

cillatory nature of tides, their overall
ought to be zero. This may not be true

currents. Due to the c
net effect on structure

given the sloping nature of the bottom. The already described relic structures appear to indicate that tidal activity neither builds nor maintains ripple marks in this region. Water soluble dye injected by a diver-carried water pistol produced net flows both to the north and to the south along the bottom. Observations could be made for only a few minutes before the dye cloud dissipated. Possibly, expendable bottom drifters and/or extended deployment of the ducted current meter could help to identify and separate tidal influence from that of the shoaling waves.

Therefore, the steepness of the sloping bottom probably creates ~~an overall current against this gradient, the supposed stronger~~ shoreward pulses of the bottom orbits may not build shoreward dipping structures within the large scale ripple marks.

CONCLUSION

To summarize the original contributions of this study, the author would like to mention three important points.

First, field work conducted during diving swims, has shown that the igneous sedimentary contact across Whaler's Cove is not a straight one as is implied in the literature.

Second, field testing has provided evidence that there are coastal marine environments in which large scale ripple marks, built under the direct influence of shoaling swell sets, may have internal structures that dip away from, not toward, the present shoreline.

Therefore, some additional care must be employed when using the

internal structure of preserved large scale ripple marks to indicate the position of the paleoshoreline.

Third, it is possible through advanced preparation and the development of appropriate techniques to conduct underwater geologic mapping.

APPENDIX OF SPECIAL EQUIPMENT AND TECHNIQUES

Basic Underwater Measuring Tools

The most essential tool is a recording tablet that will not smear while under water. Such a writing surface was the main body of an underwater inclinometer (Fig. 12). The basic board is opaque yellow plastic 0.5 cm x 27 cm x 35 cm. Mounted to the board is a Suunto submersible compass. This enables divers to rapidly take magnetic compass readings of such items as direction of dip of a ripple face, line of strike of a crest, orientation of a ducted current meter axis, and directional trends of any other observed features. It should be obvious to the builder that all hardware used to mount the compass should be brass, avoiding corrosion and compass misalignment.

Using the lower left hand corner of the compass mount as a pivot point, a 15 cm long brass rod was attached. This arm (1/8 inch brass welling rod) is free to swing in a plane parallel to the plastic board. About 1 cm above the indicating end of the pointer, several grams of lead wire (solder) were wrapped about the rod to give it a strong vertical seeking nature. This additional mass also provides great inertial resistance to unwanted movement caused by wave surge during measurements.

The board is scribed with an arc marked every 5 degrees. The arc is numbered such that a horizontal surface reads as zero. All inclinations are departures from the horizontal.

The whole surface of the board was sanded with fine, 400 grit, sandpaper to provide an excellent writing surface. A 4H drawing pencil

is attached to the board by 40 cm of 1 mm nylon line. This combination provides a recording slate which is unsmearable in use and requires a conscious effort to scrub it clean with an eraser post-dive.

A wrist strap, 3 cm x 20 cm x 0.7 cm, of neoprene wetsuit material formed into a loop, is fitted to the instrument. This wrist support frees the diver's hands to carry additional equipment. Also the board can be positioned further up the arm when not in use, but is always available when needed.

To accurately define the size of the ripple forms, yellow plastic measuring rods were built. Measuring 1.4 cm x 1.4 cm x 180 cm, the larger rod is made of opaque yellow plastic. Mounted on the bottom of the rod is a strip of clear plastic 8 cm x 0.5 cm x 160 cm. This base plate is attached to the rod with brass screws. The broader base spreads the weight of the plastic rod so that it does not deform the crest line of a ripple form on which it rests, (Fig. 10 - 11).

Painted in 5.0 cm increments with black paint, the result is alternating bands of black and yellow, each 5 cm wide, along the rod. A zero line is so marked, and a numerical value is painted every 10 cm along the rod.

A second smaller rod, 50 cm long, is also used. It is marked with alternating painted-unpainted bands 1 cm wide. The centimeter values are painted on the rod every other centimeter from 0 to 50. This smaller tool is used to quantify the trough to crest ripple height (Fig. 10) of the wavelength measured by the larger rod.

Large Settling Tube

The sediments in the region studied required specialized equipment to provide effective size analysis. Since the sediments are experiencing active transportation in the marine environment, hydraulic size equivalents should be the most meaningful statement of size range and size distribution.

Hydraulic size equivalent refers to the diameter of a quartz sphere having the same settling velocity as that of the tested natural grain.

An additional problem is whether the bioclastic material present is in dynamic equilibrium with the inorganic fraction of the sediments. The calcium carbonate bioclastic material constitutes upwards of 70% by weight of the sediment in portions of the study area. Mechanical sieving of such material is an unacceptable way to determine behavioral size of bioclastic fragments (Maiklem, 1968). A review of Figures 5 through 9 will give the reader a sense of the problems present.

An oversized settling tube was specially constructed and placed in the Sedimentology Laboratory at San Jose. Initial design work of the tube was done by Robert Graf under the direction of Dr. William Dillon. The tube has the following dimensions: maximum straight vertical fall length - 215 cm; inside diameter of main body column - 15 cm; length of collection tube 20 cm; inside diameter of collection tube - 1.5 cm (Fig. 21).

Introduction of the sediments is accomplished by a pair of half-moon shaped doors. The pair of doors fit directly, and horizontally,

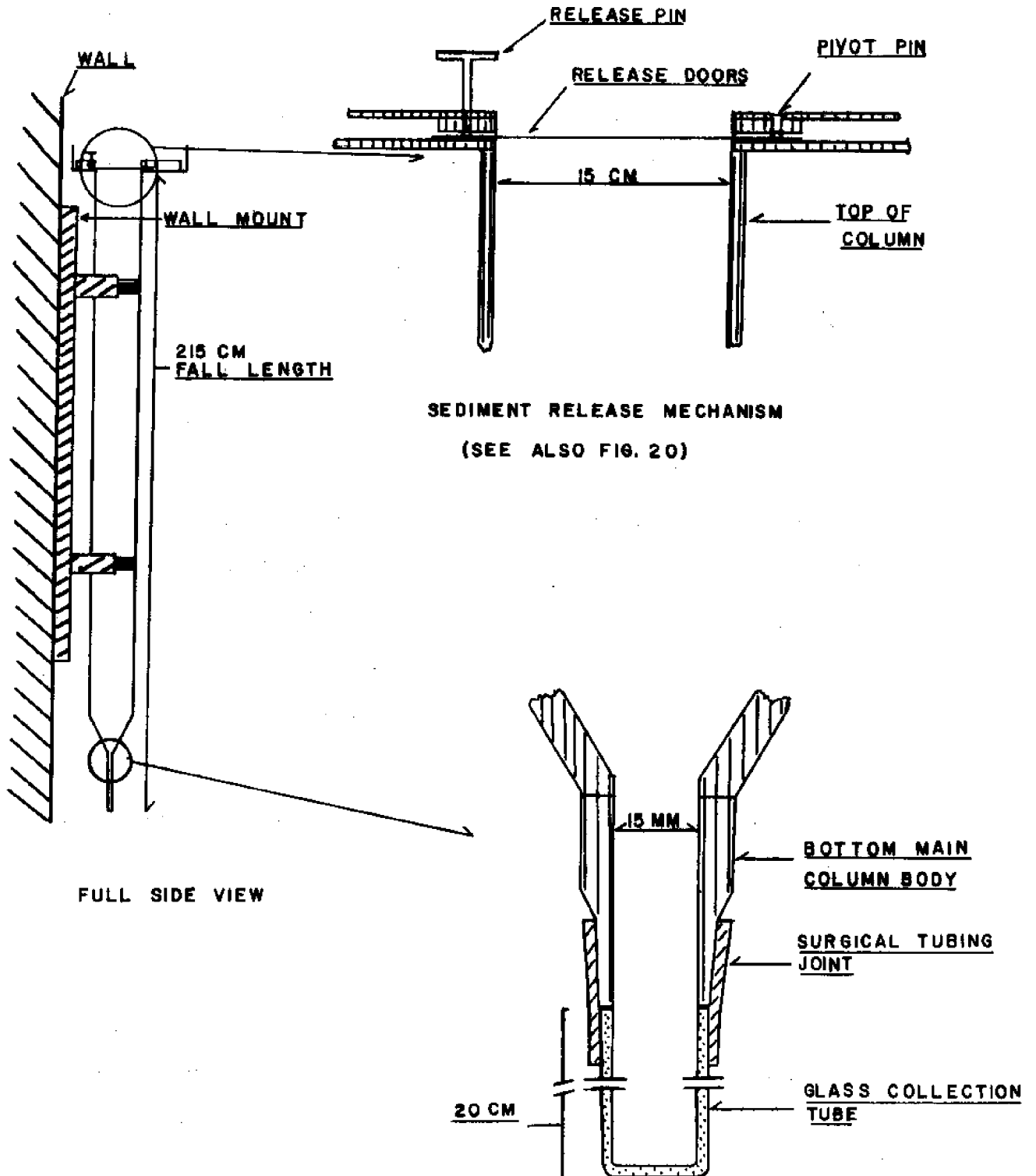

Figure 21 - Details of large settling tube used for hydraulic size analysis.

atop the upper rim of the main body column (Fig. 20). Prior to release the sediment rests on the doors in a layer no more than 3 or 4 grains thick. The material rests under 1 cm of water and is assumed to be completely wet. The arrangement allows for the absence of turbulent mass flow as encountered when using the introduction tube with the Emery Settling Column.

Critical observations found that the sediments appeared to accelerate to their respective terminal fall velocities in the first 5 - 7 cm of fall after release. Acceleration over the first 5% or less of the total fall path leaves the remaining 95+ % of the column length to effect sorting by hydraulic characteristics.

A piece of masking tape was placed along the length of the collection tube. A stop watch, started at the time of sediment release, was used to measure fixed time intervals. Marks, placed on the tape, indicate the height of the accumulated material within

the collection tube at the end of each predetermined time period.

Due to the problems of cost, calibration of the tube to equivalent quartz spheres was not accomplished. Using empirically determined natural discontinuities in the behavior of the falling material, trends in change of size with change of sample position/depth were readily quantified.

No particle arrived at the bottom of the collection tube before 7 seconds after release. First arrivals were never later than 8 seconds. This was true for 20 runs, 5 for each sample. In all samples there were some 5-6 mm lithic fragments. Immediately after the large lithic particles would be the large bioclastic

fragments (when present in the sample). There were observable size discontinuities at 15 seconds and again at 30 seconds. After a total of 60 seconds elapsed time, there was never any measurable (more than 1 mm) accumulation. Table 1 shows the results of samples from the upper-most layer within each box core of the April 6, 1972 sequence of box cores.

In order to assign some kind of size values to the fall periods, the following assumptions were made. 1) There is no appreciable delay when material falls through the conic transition from main to collection tube. 2) There is no appreciable delay due to water displaced upwards from the collection tube (probably a poor assumption). Given the above statements and using values from Zeigler and Gill (1959), the selected times indicate the following hydraulic size equivalents:

7 sec.	2.4 mm
15 sec.	0.8 mm
30 sec.	0.6 mm
60 sec.	0.3 mm

While the instrument still requires calibration for absolute measurements, it does provide a rapid technique for noting hydraulic size trends of sequential, coarse grain samples from the marine or fluvial environments.

Mobile Wave Staff System

A technique to relate the velocity of the horizontal portions

of swell induced orbits at the water-sediment interface to the surface expression of shoaling wave sets was developed. The equation expressing the above relationship is from Newton (1968, p. 288), and is as follows: $U \text{ pos. max} = 0.4C(H/h-0.62)^{0.72}$; where $U \text{ pos. max}$ is maximum horizontal velocity in direction of wave travel at the bottom, H is swell height, h is water depth, $C=L/T$, L is the length of surface swell, and T is period of surface swell. The data would allow comparison of graphs relating local sediment ripple height: $U \text{ pos. max}$ to those in Newton (1968).

A system of field mobile tethered wave staffs was constructed. During deployment each staff is anchored on station. The anchor provides SCUBA divers with a known reference point about which specific observations can be made. Observations may include size, shape, and strike of ripple forms; exact reference point for bottom sample locations; reference locus from which to note form migration. Land based transits are used both to fix the position of each staff and to observe the swell pattern as it passes each reference point (staff).

Field requirements imposed the following restrictions. The staff itself had to be visible to the transit operators. The marking system had to be readily ascertainable by the observers. Each staff had to be stable so that it did not rise and fall with the swell, nor would it swing in an arc in response to the orbiting of the passing swell. The staff and anchor had to be deployable by small craft, row boat size. Cost per staff and anchor had to be within the 25-30 dollar range.

~~Weather and sea state conditions were also limiting factors. While rain~~
~~overcast skies could be tolerated, fog would prevent transit sighting.~~

of the target. If no swell is running, there is no data generated. If the swell has significant heights greater than 1.5 - 2.0 m, then neither the support boat nor SCUBA divers can safely operate.

All materials used are readily available through local hardware stores and require no special ordering. Sections of 3 cm O.D. thin wall pipe were jointed to form the basic staff 4 m long (Fig. 22). A tin can (2 lb. coffee size) with an eye bolt mounted at one end forms the bottom and the line attachment point for the staff. 8 kg of lead was poured into the can while the axis of the pipe was held coincident with the axis of the can. This brought the center of gravity of the staff to within 30-40 cm from the bottom of the staff. A section of plastic foam (35 cm x 35 cm x 15 cm), sandwiched between two resin coated, 1 cm thick, boards provides about 5-6 kg of net positive lift for the staff. Each restraining board has a central collar which is cross bolted to the staff. This cross bolting prevents motion along the staff and rotation of the boards about the staff.

The anchor itself is a concrete construction pier with a wooden block cast in its top. An eye bolt is mounted in the center of this block. To increase the effective submerged density of the anchor, four 3 cm I.D. holes were bored into the wood and filled with additional lead. Submerged the anchor weighs approximately 14-16 kg. Field observations indicate that the anchor may need somewhat greater negative buoyancy in heavy swell sets.

The anchor line is 7 mm, yellow polyethylene line. A large snap hook is spliced onto the free end of the line for rapid

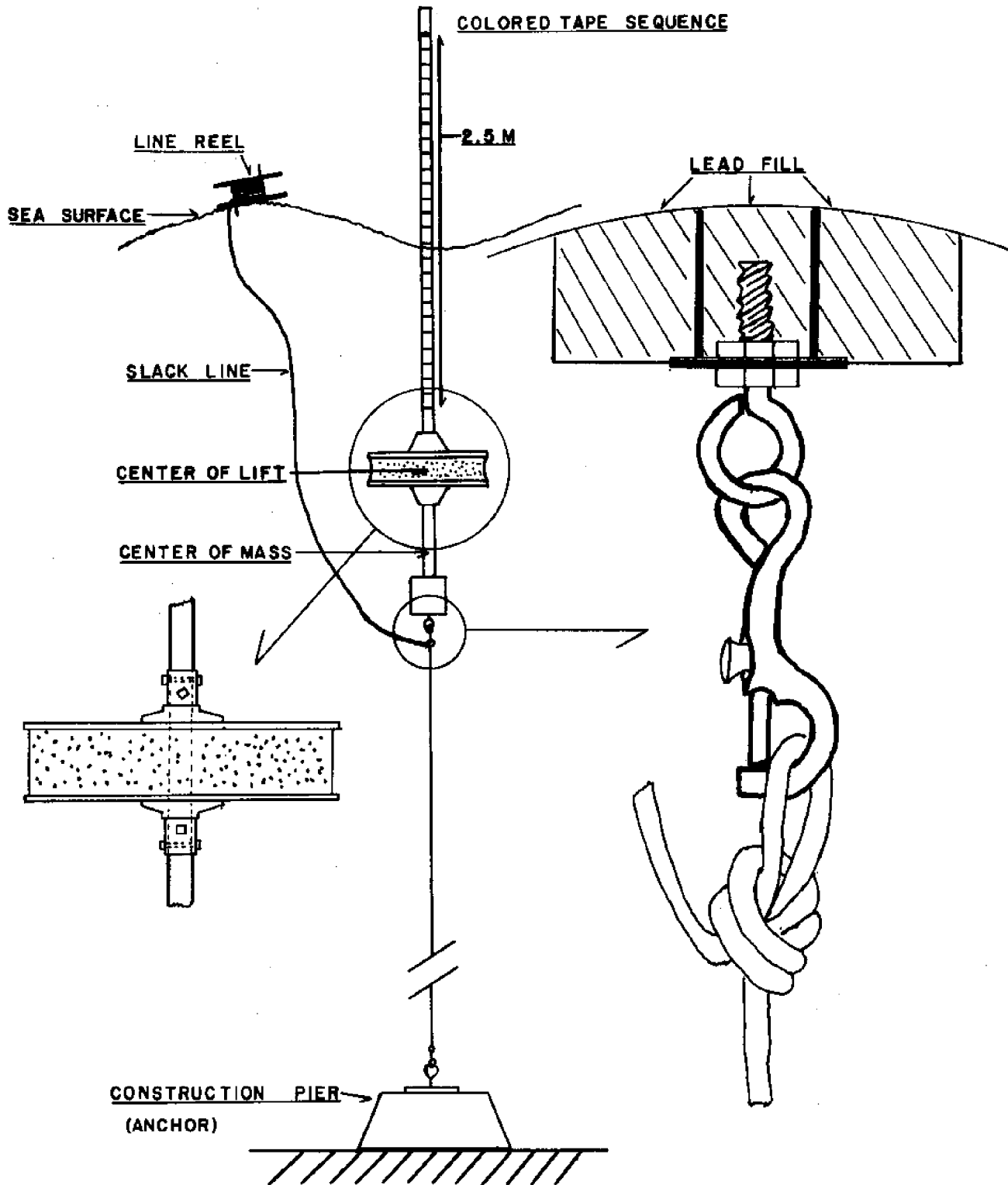

Figure 22 - Mobile wave staff system.

attachment to the anchor eye bolt. 35 m of line is wound onto a simple wooden frame. The frame is resin coated to prevent water damage.

Color markings cover 2.5 m of the staff above the flotation section. There is one complete color cycle for each whole meter; there are 2-and-one-half cycles on a staff. The colors are applied by using colored cloth adhesive tapes. Each individual color band is 10 cm wide (measured vertically). To achieve maximum color contrast, the following color sequence for each meter is used: black, white, red, white, yellow, white, blue (royal), white, brown, white. Testing has shown that this sequence has sufficient brightness and contrast to be clearly distinguishable at a distance of 400 m through a transit on an overcast day.

When the boat used to deploy the staff arrives on station, the

~~anchor line is clipped to the eye bolt on the anchor and the~~

om. Upon reaching bottom, indicated
 hor is then raised 2 m above the
 ot on a bight is tied in the line at
 meters of line is run from the
 d off so that no more line can un-
 e knot is attached to the staff by the
 om of the staff. Once the boat is
 ff, which has been held at its base,
 return to the bottom forcing the
 submerged.

anchor is lowered to the bot
 by slack in the line, the an
 bottom. A simple overhand k
 the water level. 4 or 5 mor
 frame. Then the frame is ti
 wind from it. The loop in t
 snap hook mounted on the bot
 cleared of all lines, the st
 is released. The anchor wil
 lower half of the staff to b

While the anchor and staff combined have a net negative buoyancy, the positive buoyancy and the balance configuration of the staff itself provides a strong self-righting tendency. This tendency is further enhanced because the anchor line has no scope. The frame is left floating on the water and serves as a painter line when initiating recovery of the system.

The support boat is not required to remain on station and is free for other observations until such time as the staff is recovered. Divers can relocate the anchor so that the staff is over a point of some significant value in addition to serving as a reference for passing swell set. Two or more staffs may be deployed orthogonal to the wave front so that wavelength and celerity of the waves can be measured directly.

During the period of the study, January, 1972, to April, 1972, unseasonably calm seas prevailed (personal communication with Eric Dittmer). Because of the relatively complex personnel support required for this whole operation, observations had to be made on prescheduled dates which did not coincide with periods of measurable swell states. Therefore, calculation of values for $U_{pos. max}$ was not done.

Materials, deployment craft, boat operators, fixed landpoints, transits, and transit operators, were all provided through, and in concert with, the activities of Beta Research Oceanographic Laboratories, San Jose, California.

Submersible Current Meter

Through the aid and support of Dr. Robert S. Andrews from the Department of Oceanography, U. S. Naval Postgraduate School, Monterey, California, a submersible current meter system was assembled. The goal was to acquire data on the period of the near bottom orbits in the water and the velocity of the horizontal components of each orbit. It was also hoped that a net difference between the shoreward and seaward pulses of each orbit could be detected (Fig. 23).

Data generated can be correlated with diver observations of the size, shape, and short term (several hour period) response of the bottom forms to the surge velocities recorded by this system. This data also may be correlated with the results of the technique of box coring the ripple forms which are observed to migrate during metered periods.

The sensing unit of the system is a ducted current meter, Model #B-7, manufactured by Bendix Marine Advisers, Inc. The dry cell powered, dial readout unit of the system has a velocity range of 0-15 knots. A strip chart recorder, Model G-11A, manufactured by Varian Associates provides a permanent record. A chart advance rate of 1 inch-per-minute is used. While the input signal comes from the Bendix unit, power to drive the recorder comes from a 12 VDC automobile battery. Conversion from 12 VDC to 110V, 60 Hz square wave current is provided by a Heathkit High Power Inverter, Model MP-14. Power supply, inverter, read-out unit, and chart recorder are all kept in a surface support boat

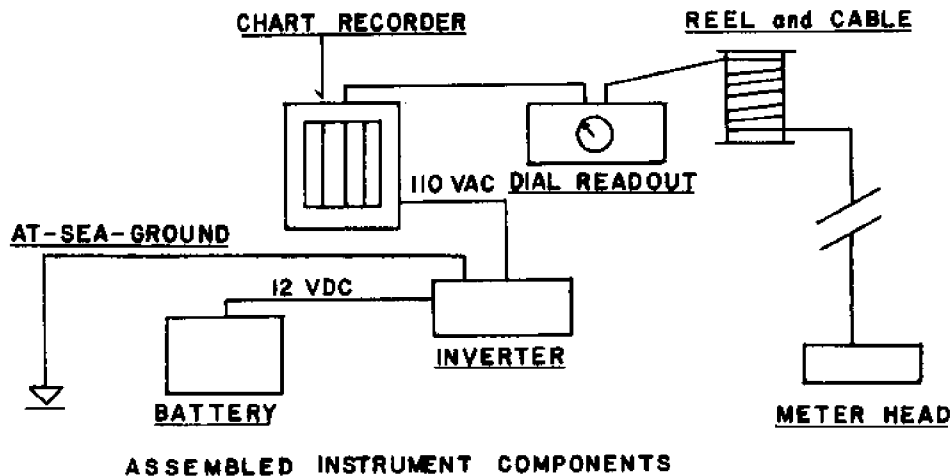
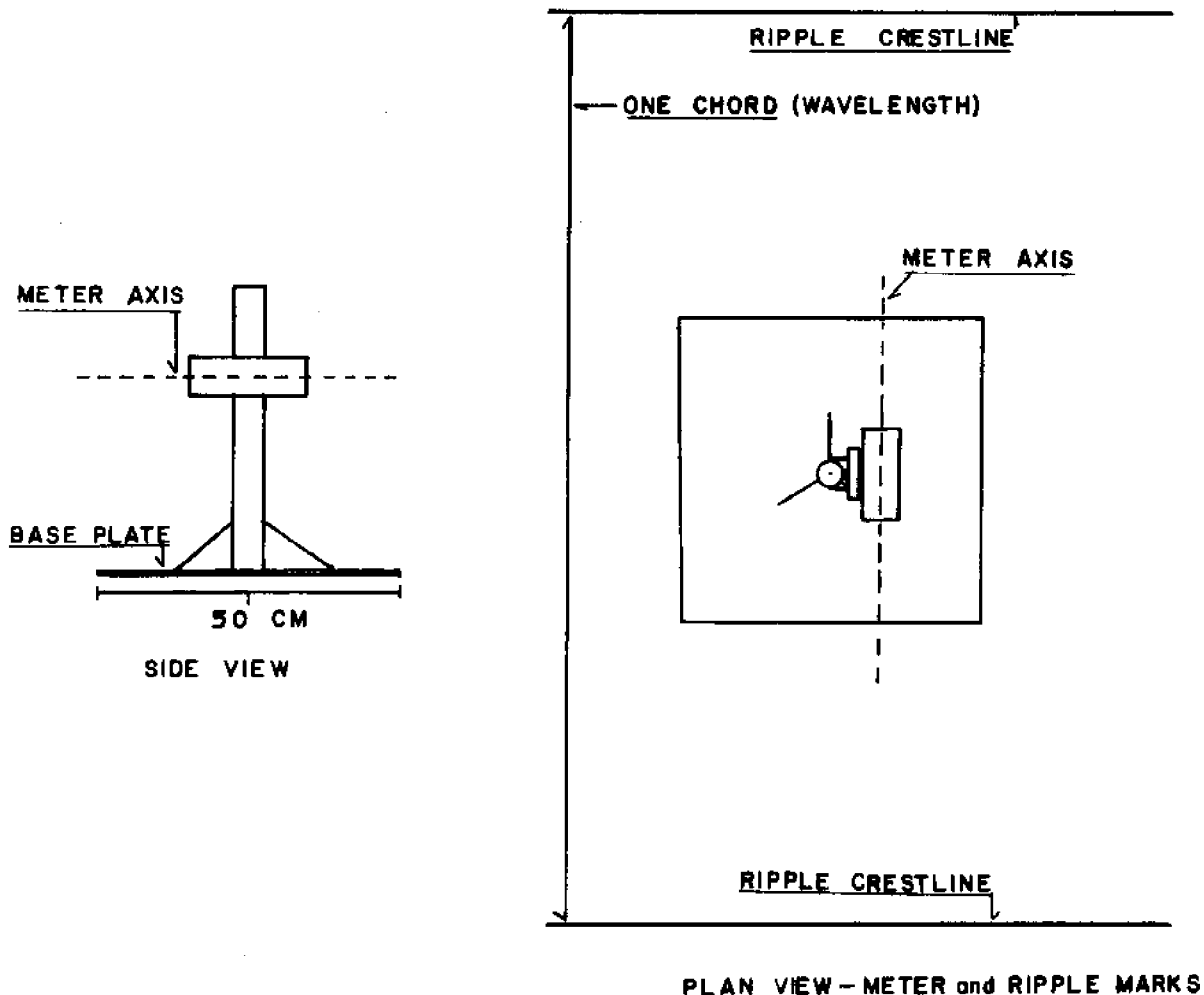

Figure 23 - Submersible current meter system shown as oriented and assembled.

during operation. An at-sea-ground is created by attaching one end of a woven steel cable to the inverter and hanging the majority of the cable overboard into the water.

Signals from the sensing head to the surface are carried by a conducting armored cable. The cable is not only the signal path, but also is used to raise and lower the meter head and support base.

The support base is a stable platform for the ducted meter, even during periods of high bottom surge. A simple configuration for the stand is achieved by having a 5 cm O.D. pipe, 50 cm long, butt welded perpendicular to a flat base plate. The base is 50 cm x 50 cm x 1.25 cm plate steel. Small, 7 mm thick, triangular braces, spaced 120° apart, provide support to prevent the pipe from shearing from the plate. The whole stand weighs about 25 kg. A pair of U-bolts mount the metering unit to the pipe such that the long axis of the meter is parallel to the bottom. Metering can be done at any preselected height above the bottom along the pipe.

Sufficient cable is paid out to decouple the motion of the support boat from the meter. Thus, the boat is not directly over the meter and, unlike the wavestaff system, the exact map location is not accurately known.

Usually two separate small boats are used. All of the electronic gear is placed in a row boat and towed to station by a second boat. Divers and surface instrument operators ride in the towing boat. All diver support is done from the towing boat to reduce the risk of wetting the recording instruments.

Once the system is operating and the chart marked with an initial time indicator, the instruments may be left unattended for upwards of 4 hours. The towed boat having been anchored on station, all personnel are relieved from remaining on station the whole time.

Divers are absolutely necessary to the success of this technique.

Surface operators have no control of the orientation of the ducted current meter when it reaches bottom. Divers orient the duct so that it senses surge perpendicular to the crest line of the sand ripples.

Direction and time of placement, along with all other pertinent bottom observations should be immediately recorded on a diver's writing board.

This data is the basis for all velocity to bottom characteristic correlations. Experience repeatedly has shown that data not recorded while under water will probably be forgotten before surfacing. The

is particularly true for small details such as compass bearings and depth readings.

Additionally, divers should use a flipper to force a strong pulse of water through the meter after the meter and base has been properly oriented. This action puts a permanent event mark on the record for later reference. The diver should record the time and the direction toward which the thrust is made. An event should also be marked before and after any subsequent repositioning of the meter.

The meter does not differentiate from which direction the water is passing through the duct. A whole orbit is represented by two velocity peaks on the record (Fig. 13). Flipper pulses provide a reference direction for record interpretation.

The two most easily identified values on the record are wave period and maximum velocity. Additional wave parameters require digitization of the record for statistical treatment or for transformation statements of the wave spectrum.

It had been hoped that simultaneous operation of the wave staffs and the ducted current meter would be run. This would have provided a field check of the validity of the horizontal velocities computed from the wave staff data. Delays in the assembling and calibration of the current meter system, beyond the control of the author, prevented such field checking.

This system has been found to be fully field operational as described. Further deployment and a statistical reduction of the record should prove to be a great aid toward a better understanding of sedimentary response to wave action.

Box Core Sampling

Box coring is a term used to indicate a technique by which an oriented rectangular solid sediment sample is acquired. The least disturbed center portion of the oriented sample is permeated with casting resin. These permanently bonded slabs show whatever internal structure may exist within the sampled sediments (Fig. 15-19). A complete description of the basic procedure may be found in Clifton, et al. (1971, p. 654-655).

Field experience provides the following additions to the basic description. The assembled box cores should be marked with a

water-proof pen during pre-dive preparation. Such marks should include a sequential reference number on each separate piece (all parts of one box have the same number); and directional arrow to serve as the base line for compass orientation of each sample (Fig 14). In addition, masking tape should be used to attach a bottom plate and elastic band to each box pre-dive. This saves time and the diver's air by avoiding a search for loose pieces in an equipment bag during sampling. Once the sample is acquired, all possible care must be exercised to keep the sample in its original vertical orientation.

A further recommendation would be to consider constructing a box core with a removable top section. This would eliminate the hydraulic compression effect encountered when driving the box into the sediments.

Experience in post-dive processing of the samples produced the following recommendations and cautions. Care must be used when transferring the sample from the box core to the casting tray. Thus the sediments experience a minimum amount of unnecessary disturbance. The tray itself should be clearly labeled to show the number and original orientation of the sample it contains. It is absolutely necessary that the samples be oven dried before pouring on the casting resin. This is true at least for the TAP Clear Casting Resin used. Twenty to forty cc's of prepared resin should suffice when poured evenly over the samples as coarse as those of this study.

Once the resin has hardened, the cast slab may be handled and inspected. While most samples showed evidence of internal structure when viewed directly, X-ray images were taken to further identify the

layering and structural features. A Field Emission Faxitron, Model 804, manufactured by the Field Emission Corporation of McMinnville, Oregon, was used. The pass-through images were exposed on Polaroid Type 52 film. This film gives an immediate positive image and avoids time spent developing normal X-ray negative film. This process permits the operator to make exposure compensations to get improved images right away. The X-ray facility and materials were provided through the courtesy of Dr. H. Edward Clifton of the U. S. Geological Survey, Marine Geology Division, Menlo Park, California.

REFERENCES

- Allen, J. R. L., 1968. Current ripples: their relation to patterns of water and sediment motion: North-Holland Publishing Co., Amsterdam, 433 p.
- Bascon, W. A., 1964. Waves and beaches - The dynamics of the ocean surface: Anchor Books, Doubleday and Co., Inc., New York, 267 p.
- Clifton, H. E., Hunter, R. E., and Phillips, R. L. 1971. Depositional structures and processes in the non-bared high-energy nearshore: Jour. Sed. Petrology, V. 41, p. 651-670.
- Graf, R. J., 1971. A study of the Sediments in an Active Marine Channel in Point Lobos Reserve, California: Unpublished Study for Geol. 127, San Jose State University, California, 9 p.
- Harms, J. C., 1969. Hydraulic significance of some sand ripples: Geol. Soc. American Bull., V. 80, p. 363-396.
- Inman, D. L., 1963. Ocean waves and associated currents, p. 49-81 in Shepard, F. P., 2nd ed.; Harper and Row, Publishers, New York, 557 p.
- Maiklem, W. R., 1968. Some hydraulic properties of bioclastic carbonate grains: Sedimentology, V. 10, p. 101-109.
- Neumann, G., and Pierson, W. J., Jr., 1966. Principles of Physical Oceanography: Prentice-Hall, Inc., Englewood Cliffs, New Jersey, 545 p.
- Newton, R. S., 1968. Internal structures of wave-formed ripple marks in the nearshore zone: Sedimentology, V. 11, No. 3/4, p. 275-292.
- Nichols, D. R., ed., 1970. Eighteen month report - Total ecological survey at Point Lobos State Reserve, Carmel, California: Unpublished, Beta Research Oceanographic Laboratories, San Jose, California, 42 p.
- _____, 1971. Thirty month report - Point Lobos ecological study: Unpublished, Beta Research Oceanographic Laboratories, San Jose, California, 43 p.

- Nili-Esfahani, A., 1965. Investigation of Paleocene strata, Point Lobos, Monterey County, California: M.A. Thesis, Univ. of Calif., Los Angeles, 228 p.
- Shepard, F. P., 1963. Submarine Geology, 2nd ed.: Harper and Row, Publishers, New York, 557 p.
- Simpson, J. P., III. 1972. The Geology of Carmel Bay, California: M.S. Thesis, Naval Postgraduate School, Monterey, California, 74 p.
- Zardeskas, R. A., 1971. A Bathymetric Chart of Carmel Bay, California: M.S. Thesis, Naval Postgraduate School, Monterey, California, 108 p.
- Zeigler, J. M., and Gill, B., 1959. Tables and Graphs for the Settling Velocity of Quartz in Water, Above the Range of Stokes' Law: Woods Hole Oceanographic Institute Ref. No. 59-36, 57 p.

