

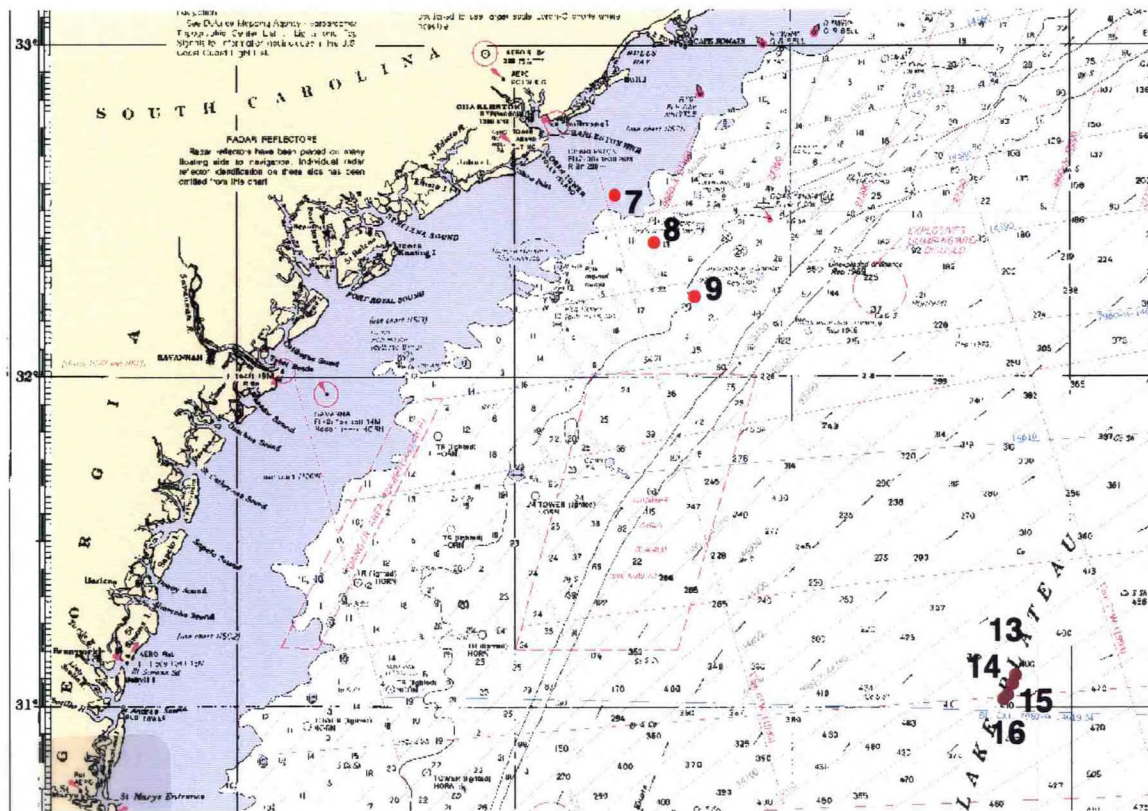

CSC Technical Report CSC/9-98/002 September 1998

NOAA CSC/CRS Cruise NOV97SAR
Sargasso Sea Cruise



Participants:

Coastal Services Center - Coastal Remote Sensing Program
Marine Laboratory - University of Charleston

CSC Technical Report CSC/9-98/002

NOAA CSC/CRS Cruise NOV97SAR: Sargasso Sea Cruise

Mary E. Culver¹
Ajit Subramaniam²
John C. Brock^{3,4}
Mark E. Geesey^{2,5}
Giacomo R. DiTullio⁵
David Jones⁵

¹TPMC/NOAA/CSC
2234 Hobson Avenue
Charleston SC 29405

²REMSA Inc.
NOAA Science Center Room 711b
4700 Silver Hill Road, Stop 9910
Washington DC 20233-9910

³NOAA Coastal Services Center
2234 South Hobson Avenue
Charleston, SC 29405

⁴now at U. S. Geological Survey
Center for Coastal Geology
600 4th St. So.
St. Petersburg, FL 33701

⁵Grice Marine Laboratory
University of Charleston
205 Fort Johnson
Charleston SC 29412

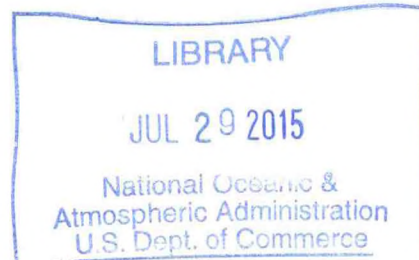

QH
541.5
.C65
C71
no. CSC/
9-98/002

September 1998

UNITED STATES DEPARTMENT OF COMMERCE
National Oceanic and Atmospheric Administration
COASTAL SERVICES CENTER
2234 South Hobson Avenue, Charleston, SC 29405-2413



Table of Contents

I.	Introduction.....	1
II.	Objectives	1
III.	Methods.....	1
	A. Sampling Locations	1
	B. Sampling Platform	1
	C. Sample Collection Methods Summary	3
	D. Sampling Gear	3
	E. Bottle Samples	5
	F. Along-Track Measurements.....	6
	G. Optical Data Processing.....	6
	H. Backscattering Data Processing	7
	I. Image Processing	7
IV.	Results	8
	A. Bottle Samples	8
	B. Along-Track Data	10
	C. Optical Data	10
	D. Algorithm Evaluation.....	11
	D. Backscattering Data	12
	E. SeaWiFS-Derived Data.....	13
V.	Summary.....	15
VI.	References.....	16
VII.	Metadata	16
VIII.	Appendix A - Water Column Profile Data Figures	24
IX.	Appendix B – Sub-surface Light Field Estimation Statistics.....	49
X.	Appendix C - Example Profile Header Information	54
XI.	Appendix D - Calibration Certificates.....	58
XII.	Appendix E – Backscattering Coefficient Profile Data Figures	70

Abstract

The South Atlantic Bight consists of a variety of environments including near-coastal and continental shelf regimes, the Gulf Stream, and the Sargasso Sea. The variability in the biological and optical characteristics of these regimes complicates any temporal or spatial analyses of changes in, for example, phytoplankton species composition, primary production rates, colored dissolved organic matter concentration, suspended sediments, or temperature.

Measurements of surface chlorophyll fluorescence, temperature, and salinity were made during a cruise on November 3 – 5, 1997. Water column profiles of temperature, chlorophyll fluorescence, scattering, beam transmittance, upwelling radiance, and downwelling irradiance were made at 8 stations on a transect from Charleston, SC, southeast across the Gulf Stream, into the Sargasso Sea. The measurements were compared with ocean color imagery from the NASA/OrbImage Sea Wide Field of view Sensor (SeaWiFS) to provide a means to extrapolate point measurements to a large horizontal scale.

A smooth transition from low temperature waters with high pigment concentrations and attenuation coefficients, that are typical of nearshore environments, to the higher temperature waters with low pigment concentrations and attenuation coefficients, that are typical of offshore environments, was disrupted by a warm Gulf Stream eddy that was present on the continental shelf. The eddy was characterized by high pigment concentrations and a more diverse phytoplankton community than the other environments sampled. The regimes were evident in satellite imagery.

List of Figures

Figure 1. Location of Stations	2
Figure 2. Position of Instruments on the PRR Cage.....	4
Figure 3. Cabling Diagram for the PRR Cage.....	5
Figure 4. Along-Track HPLC Pigment Concentrations.	9
Figure 5. Along-Track Temperature and Salinity.....	10
Figure 6. SeaWiFS pigment image for November 4, 1997.....	13
Figure 7. Comparison normalized water leaving radiance.....	14

List of Tables

Table 1. Station Notes Indicating Date, Time, Location and Sky Conditions.....	2
Table 2. Center Wavelengths for the PRR System.....	3
Table 3. HPLC Pigment Abbreviations and Indicators.	8
Table 4. Algorithm Evaluation	11
Table 5. SeaWiFS image chl <i>a</i> concentrations, corresponding <i>in situ</i> chl <i>a</i> from fluorometric and HPLC analysis, and the OC2 algorithm.....	15

Acknowledgments

We thank the master and crew of R/V *Palmetto*, South Carolina Department of Natural Resources.

Data Usage Constraints

Users of this data are required to provide appropriate attribution in the form of co-authorship for any publications that use this data, unless formal permission to do otherwise is granted by NOAA/CSC.

I. Introduction

The South Atlantic Bight consists of a variety of environments including near-coastal and continental shelf regimes, the Gulf Stream, and the Sargasso Sea. The variability in the biological and optical characteristics of these regimes complicates any temporal or spatial analyses of changes in, for example, phytoplankton species composition, primary production rates, colored dissolved organic matter concentration, suspended sediments, or temperature. Ocean color satellites provide synoptic data of phytoplankton biomass and could be a useful tool for analysis of spatial and temporal variability. For this tool to be useful, algorithms that relate satellite data to chlorophyll biomass need to be developed and validated for the diverse conditions found in this area.

II. Objectives

The primary objective of this cruise was to collect bio-optical data to support regional case II algorithm development. The water-leaving radiance calculated from these measurements was compared to those derived from the NASA/OrbImage SeaWiFS ocean color sensor, in order to assess the sensor's calibration.

III. Methods

A description of the sample collection methods and of instruments used is detailed in the following sections.

A. Sampling Locations

On November 3, six stations were occupied to obtain depth profiles of pigments, temperature, and salinity. Three stations were occupied on November 4 and three stations on November 5 to obtain these same measurements as well as measurements of upwelling radiance and downwelling irradiance (Table 1, Figure 1). Surface water samples were acquired along-track for chlorophyll, temperature and salinity.

B. Sampling Platform

The R/V *Palmetto* that belongs to the South Carolina Department of Natural Resources was used for this cruise.

Table 1. Station Notes Indicating Date, Time, Location and Sky Conditions

Date	Station	Lat Deg	Lat Min	Latitude	Long Deg	Long Min	Longitude	Start Time	PRRFile	Sky Conditions
11/3/97	1	31	45.18	31.753	-79	4.20	-79.070	0700	N/A	
11/3/97	2	31	56.58	31.943	-79	0.06	-79.001	0950	N/A	
11/3/97	3	32	3.96	32.066	-79	2.94	-79.049	1140	N/A	
11/3/97	4	32	10.32	32.172	-79	10.32	-79.172	1310	N/A	
11/3/97	5	32	13.80	32.230	-79	17.94	-79.299	1445	N/A	
11/3/97	6	32	18.60	32.310	-79	28.56	-79.476	1630	N/A	
11/4/97	7	32	32.56	32.543	-79	36.96	-79.616	1215	971104A	Clear
11/4/97	8	32	23.97	32.399	-79	28.55	-79.476	1415	971104B	Clear
11/4/97	9	32	14.39	32.240	-79	20.18	-79.336	1615	971104C	Clear
11/5/97	10	31	7.80	31.130	-78	13.38	-78.223	0400	N/A	
11/5/97	13	31	4.52	31.075	-78	11.88	-78.198	1000	971105B	Overcast
11/5/97	14	31	3.63	31.061	-78	12.32	-78.205	1200	971105C	Clouds
11/5/97	15	31	1.92	31.032	-78	13.26	-78.221	1400	N/A	
11/5/97	16	31	1.12	31.019	-78	14.12	-78.235	1600	971105D	Overcast

Lat Deg, Lat Min, Long Deg, and Long Min refer to the station position in degrees and decimal minutes, Latitude and Longitude refer to the station position in decimal degrees. Time is in EST. PRRFile: file name of the raw data acquired by the instruments in the PRR cage.

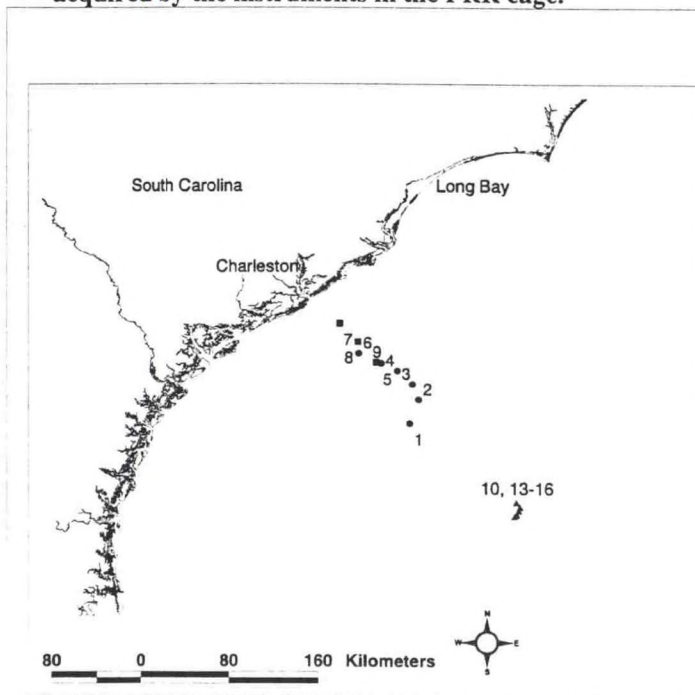

Figure 1. Location of Stations

Stations occupied on November 3 are indicated by circles; November 4, squares; November 5, triangles.

C. Sample Collection Methods Summary

The Profiling Reflectance Radiometer (PRR) cage, described below, was deployed off the stern of the boat, to measure *in-situ* spectral downwelling irradiance, spectral upwelling radiance, temperature, chlorophyll fluorescence, light scattering, quantum scalar irradiance, and beam attenuation. Following the PRR cast, a Hydro-Optics, Biology, and Instrumentation Laboratories, Inc. (HOBILabs) HydroScat-6 spectral backscattering sensor was lowered by hand. An along-track system was used to measure the position (latitude, longitude), time, course and speed of the vessel, temperature, and salinity. The along-track system used water pumped through a deck hose by a bilge pump from an intake located about a meter below the sea surface. *In-situ* temperature, salinity, and density were also measured at some stations with a Conductivity-Temperature-Depth (CTD) instrument. Water samples for chlorophyll biomass, particulate, and dissolved absorption were obtained from a separate cast using a Niskin array.

D. Sampling Gear

The PRR cage (Figures 2 and 3) contained a split PRR600s (Serial No. 9643) that measured seven channels of downwelling irradiance, seven channels of upwelling radiance, depth, tilt, roll, and temperature. A reference surface unit (PRR610 Serial No. 9644) that measured seven matched channels of surface downwelling irradiance on deck was also used. Channels 1 to 6 were narrow band (10-nanometer [nm] full width half maximum [FWHM]) centered at the indicated wavelengths, while channel 7 on the downwelling sensor and PRR610 measured broad band Photosynthetically Available Radiation (PAR) (400 to 700 nm).

Channel No.	PRR600s Downwelling Light Sensor	PRR600s Upwelling Light Sensor	PRR610
1	380 nm	380 nm	380 nm
2	412 nm	412 nm	412 nm
3	443 nm	443 nm	443 nm
4	490 nm	490 nm	490 nm
5	510 nm	510 nm	510 nm
6	555 nm	555 nm	555 nm
7	PAR	683 nm	PAR

Table 2. Center Wavelengths for the PRR System

The cage also contained a 10-centimeter (cm) pathlength, 660 nm Light Emitting Diode (LED) based SeaTech transmissometer (Serial No. 664), a Biospherical Instruments Quantum Scalar Profiling sensor (QSP200, Serial No. 4443), a SeaTech light scattering sensor (LSS, Serial No. 281), and a WETLabs Wetstar chlorophyll fluorometer (Serial No. Ws3-088). Water was drawn through the fluorometer using a SeaBird pump (Serial No. 051363) running at 2,000 revolutions per minute. The data from these instruments were multiplexed through the PRR600s such that each record contained a depth and parameters from every instrument. Figure 2 shows the cabling diagram for these instruments. The calibration history for all these instruments is given in Appendix D.

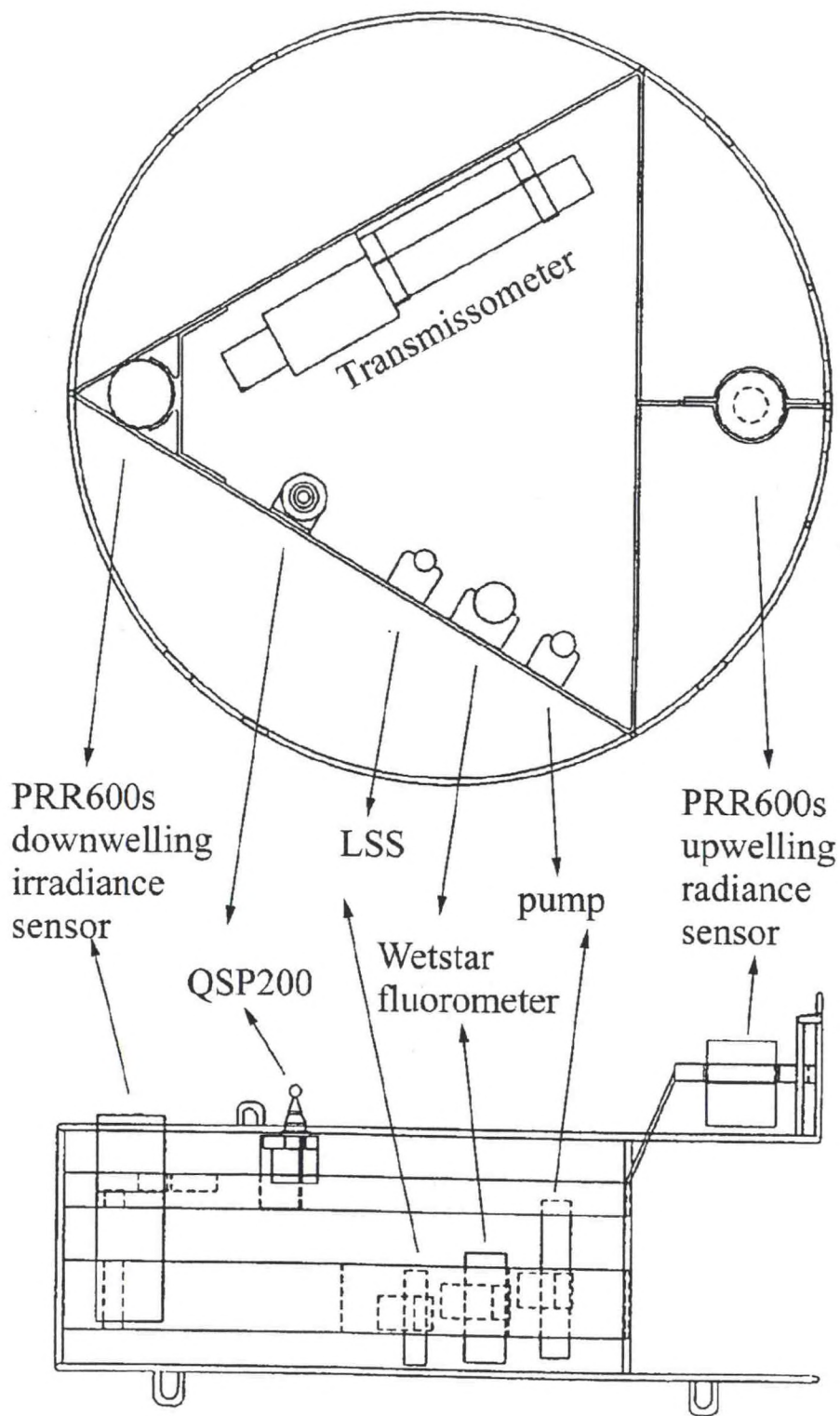

Figure 2. Position of Instruments on the PRR Cage.

(Figure adapted from BSI manual)

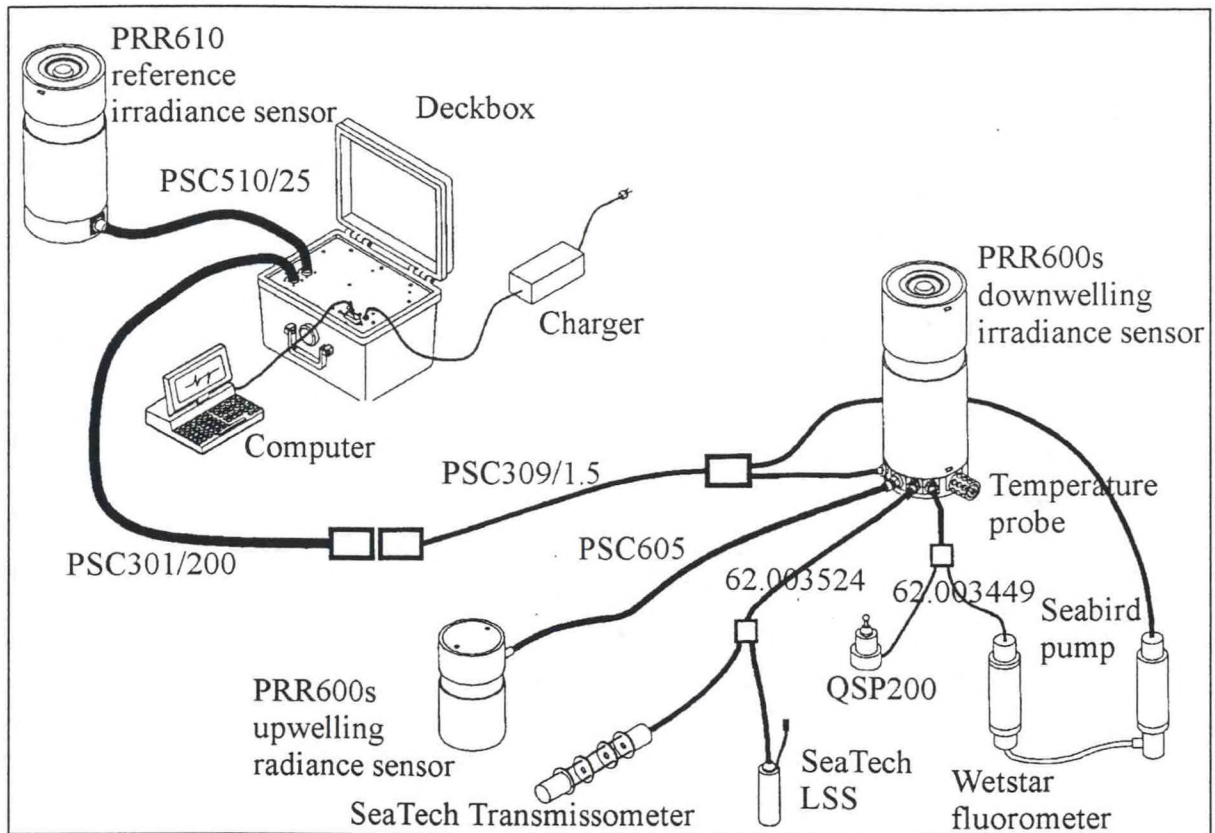

Figure 3. Cabling Diagram for the PRR Cage.

(Figure adapted from BSI manual)

The Hydrosat-6 is a self-contained instrument designed to measure the spectral backscattering coefficient at six wavelengths. The wavelengths are 440, 470, 510, 590, 620, and 670 nm, each with a 10-nm bandwidth.

E. Bottle Samples

Discrete water samples were collected following the PRR cast, from just below the sea surface using a Niskin bottle. For fluorometric chl *a*, 2320 ml was filtered; and for HPLC samples, 4640 ml was filtered through glass fiber (GF/F) filters.

The chlorophyll *a* samples were cold extracted in 10 ml of 90% acetone (10% water) for 24 hours in the dark and the biomass was determined fluorometrically with a Turner Designs fluorometer using the method of Yentsch and Menzel (1963).

Filtered HPLC pigment samples were cut into small pieces, ground, and extracted in a 1.5 ml microcentrifuge tube with 1.5 ml 90% acetone and placed in a freezer overnight. They were centrifuged at 0°C for 15 minutes, 0.5 ml was filtered through a Nalgene nylon syringe filter, the samples were diluted to 60% acetone with the addition of 0.25 ml water, and 0.5 ml was injected into the HPLC.

A Hewlett-Packard 1050 Series HPLC with a Phenomenex Sphericlone ODS(2) reverse-phase column (250 mm x 4.5 mm with 5 μ m particles) was used with a ternary gradient to separate and identify the photosynthetic pigments. The three solutions were: A: Water; B: Methanol; C: 85% Methanol/15% 0.5 Molar Ammonium Acetate (pH 7.6). The 41-minute gradient method was as follows (adapted from Wright *et al.* (1991):

Time(min)	%A	%B	%C	Flow rate(ml/min)
0	2	0	98	1.0
5	2	0	98	1.0
6	15	85	0	1.0
10	10	90	0	1.25
30	0	100	0	1.25
36	0	100	0	1.90
39	0	100	0	1.90
39.5	2	0	98	1.5
41	2	0	98	1.0

A diode array detector recorded spectra every five seconds at wavelengths from 350 to 600 nm. Chromatograms were monitored at 440 nm (for carotenoids and chlorophylls) and 405 nm (for chlorophyllides, phaeophorbides, and phaeophytins). In addition, a fluorescence detector measured fluorescence at 666 nm using an excitation at 421 nm (maximized for chlorophyll *a*). The system was calibrated using spectrophotometrically determined concentrations of purified pigments from algae cultures maintained in the lab.

F. Along-Track Measurements

Water from about one meter below the sea surface was pumped through a hose into a bucket in which a Hydrolab Datasonde 3 Multiprobe logger was immersed. The Datasonde was used to measure temperature, specific conductivity, and salinity. This instrument had an internal data logger with a clock that time stamped each measurement and was set to sample every two minutes. A computer equipped with a Socket Communications PCMCIA card using Trimble Navigation's Global Positioning System (GPS) was used to log time, latitude, longitude, speed, and course of vessel. The clocks on the various computers were synchronized to GPS time and the time stamp on each measurement was used to merge the GPS location with the parameters measured.

G. Optical Data Processing

The PRR data was processed using the Bermuda Bio-Optics Project (BBOP) processing software (Siegel *et al.* 1995). A least common denominator (LCD) file was created from the binary data files, the cast card files, the calibration files, and cruise notes. The LCD file header contains the metadata for the cast and includes information on the parameters sampled, parameters derived, filters used, and the statistical results of the regression used to extrapolate light to the sub-surface. An example header is presented in Appendix C. The pressure channel data was recalculated using an offset to adjust for the distance of the pressure sensor from the cosine collector. The tops and bottoms of the individual profiles were marked using an interactive Matlab[®] script and the corresponding record numbers

were inserted into the LCD header section. Data less than the dark threshold was replaced by -9.9×10^{35} . Then the data was quality controlled using flags for data with tilt and roll angles greater than 10° (flag value greater than 0 in the "aq-1Tilt-1Roll" field), and records where the surface incident irradiance was not uniform (flag value greater than 0 in the "kq-1ed412" field). The temperature, transmissometer, and fluorometer data were despiked, in two passes, with a difference threshold. A moving average was calculated for these channels. The data were separated into upcast and downcast profiles and then binned to 0.5-m bins. Spectral attenuation coefficients were calculated for the optical channels over a five point moving window. Subsurface downwelling irradiance and upwelling radiance were extrapolated to just below the surface using data from the top 3 meters.

H. Backscattering Data Processing

The HydroScat-6 data were processed using IDL software. A calibrated data file was created using software provided by HOBI Labs, Inc. Data less than the dark threshold was replaced by -9.9×10^{35} . The data were despiked, in two passes, with a difference threshold. A moving average was calculated for these channels. The data were separated into upcast and downcast profiles and then binned to 0.5-m bins.

I. Image Processing

The November 4, 1997 image from the OrbImage/NASA Sea-viewing Wide Field of view Sensor (SeaWiFS) ocean color satellite was retrieved from the NASA Goddard Data Archive Center in Level 1a format. It was processed using the SeaWiFS Data Analysis System (SeaDAS) to Level 1b using the local values for climatology and atmospheric conditions. The SeaWiFS Project algorithm (OC2 – O'Reilly *et al.* In press) was used to derive satellite pigment (C) from radiance measurements.

$$C = -0.040 + 10^{(0.341 - 3.001X + 2.811X^2 - 2.041X^3)}$$

where

$$X = \log_{10} \frac{R_{rs}(490)}{R_{rs}(555)}$$

and the remote-sensing reflectance at a wavelength ($R_{rs}(\lambda)$) is defined as the ratio of the water-leaving radiance ($L_w(\lambda)$) to the downwelling irradiance above the surface of the water ($E_s(\lambda)$).

$$R_{rs}(\lambda) = \frac{L_w(\lambda)}{E_s(\lambda)}$$

IV. Results

Results of the study are detailed below.

A. Bottle Samples

The nearshore environment the community was dominated by diatoms, as evidenced by large concentrations of Fucox along with Diad, Diat, and Chl *c*1+2 (see Table 3 for abbreviations, Figure. 4). Cyanophytes also were abundant in the near-shore as evidenced by high levels of Zeax. Other members of the community included Chlorophytes, Prymnesiophytes, and Haptophytes. Further from shore the relative proportions of the community remained constant while the overall abundance decreases.

Table 3. HPLC Pigment Abbreviations and Indicators.

Pigment	Abbreviation	Phytoplankton Group
Chlorophyll <i>a</i>	Chl <i>a</i>	all
Divinyl chlorophyll <i>a</i>	DV Chl <i>a</i>	Prochlorophytes
Chlorophyll <i>b</i>	Chl <i>b</i>	Chlorophytes, Prochlorophytes
Chlorophyll <i>c</i>	Chl <i>c</i>	Protists
Diadinoxanthin	Diad	Diatoms
Diatoxanthin	Diat	Diatoms
Fucoxanthin	Fucox	Diatoms, others
Lutein	Lutein	Chlorophytes
Peridinin	Perid	Dinoflagellates
Zeaxanthin	Zeax	Cyanobacteria, Rhodophytes.
19'-Butanoyloxyfucoxanthin	19-But	Prymnesiophytes
19'-Hexanoyloxyfucoxanthin	19-Hex	Haptophytes

In the eddy, there were higher concentrations of all pigments, particularly Chl *c*1+2, Chl *b*, DV Chl *a*, Perid, 19-Hex, Fucox, and 19-But. The eddy had the most diverse phytoplankton community composition than the other environments. Diatoms were still the most abundant group, and Haptophytes, Chlorophytes, and Prymnesiophytes contributed significantly to the overall biomass. Dinoflagellates, Cyanophytes, and Prochlorophytes represented minor groups in the community.

At the outer edge of the eddy and into the Gulf Stream (100 to 110 km), large concentrations of DV Chl *a* were observed. Within the Gulf Stream the community transitioned from the shelf community, dominated by Eukaryotic algae, to the Sargasso Sea community, dominated by Prokaryotic algae. Concentrations of all pigments, except Zeax and DV Chl *a*, decreased to low levels. From the relative proportions of the pigments, the community composition in the Gulf Stream appeared more similar to that of the Sargasso Sea than to that of the shelf.

The Sargasso Sea community was dominated by Cyanobacteria. Nearly half of the total Chlorophyll was DV Chl *a* (Prochlorophytes) and over half of the total Carotenoids was

Zeax (Cyanophytes). Protistan algae made up a minor portion of the phytoplankton community.

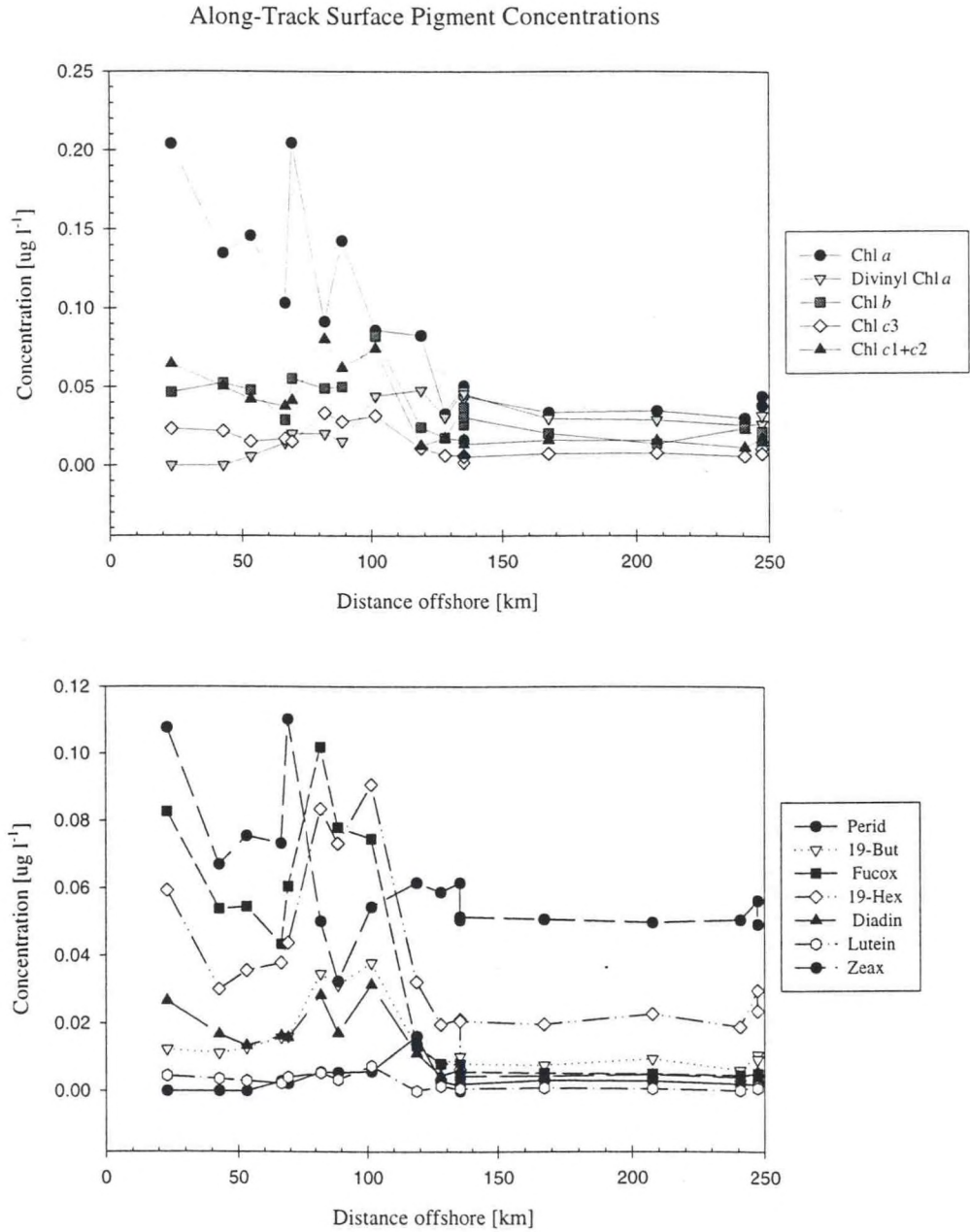

Figure 4. Along-Track HPLC Pigment Concentrations.

B. Along-Track Data

In the nearshore environment salinity and temperature are lower than further offshore (Figure 5). Across the shelf, salinity and temperature generally increase until the Gulf Stream is reached at 110 km. An eddy on the shelf between 60 and 100 km from shore (see satellite imagery) served to complicate a smooth transition from shore to Gulf Stream waters. The eddy is evident by variations in the salinity and temperature values. In the Gulf Stream (110 to 140 km from shore) salinity and temperature values are maximal (36.5 ppt and 27.5°C, respectively). The Sargasso Sea is characterized by consistently high salinity (36.5 ppt), a lower temperature (26.3°C) than the Gulf Stream.

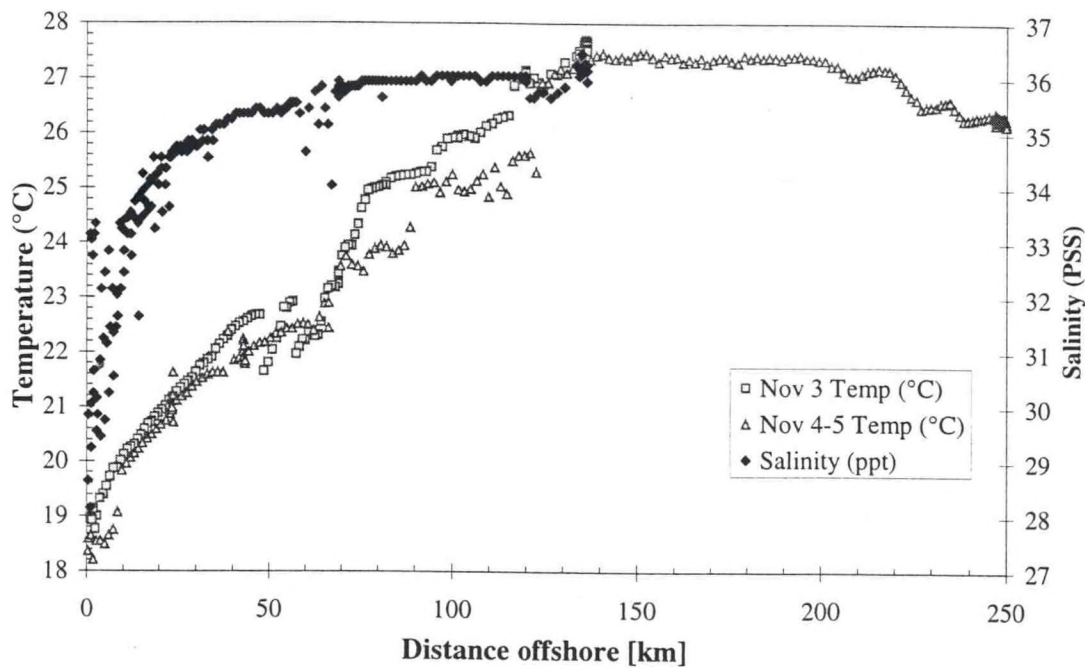

Figure 5. Along-Track Temperature and Salinity

C. Optical Data

The profiles of light are shown in Figures in Appendix A and the results are summarized in Table 4. Ship shadow affected surface measurements of Stations 7 and 14. Station 9 was measured under conditions of low sun angle and the up and down casts differed by more than is normal. Station 16 shows reduced downwelling irradiance and upwelling radiance near the surface. In general, irradiance attenuation was higher for stations nearshore than for the offshore stations. The above surface downwelling irradiance (E_s) should be constant during a profile if there was no change in the light field due to passing clouds etc. This was tested by calculating the coefficient of variation (standard deviation/mean) for E_s and is shown in Table 4. The large change in E_s at stations 13

and 14 are due to moving clouds while the change in E_s at station 9 was due to the low sun angle when the measurements were made.

D. Algorithm Evaluation

The downwelling irradiance and upwelling radiance were extrapolated to the null depth just below the surface (E_0^-) by the BBOP software. The downwelling irradiance was propagated through the water-air interface using a transmission loss of 4% (SeaBAM Tech memo). The upwelling radiance was propagated through water-air interface using a factor of 0.544 (SeaBAM Tech memo). The above water (E_0^+) downwelling irradiance and upwelling radiance are shown in Table 5 ($E_d+(\lambda)$ and $L_u+(\lambda)$ respectively). The above water downwelling irradiance measured by the reference sensor mounted on the ship are also shown ($E_s(\lambda)$) along with the coefficient of variation of this measurement ($E_s\lambda Err$). The difference between the measured downwelling irradiance (E_s) and the calculated downwelling irradiance (E_d+) was calculated and shown in Table 4 ($ds\lambda$). The remote sensing reflectance ($R_{rs}\lambda$) was calculated using either E_s or E_d+ , which ever was more appropriate. The SeaWiFS OC2 algorithm (O'Reilly *et al.* In press) was then used to calculate the satellite estimates of chlorophyll a and CZCS pigment. The ratios of satellite derived to measured quantities for chlorophyll a and CZCS pigment are also shown in Table 4.

Table 4 Algorithm Evaluation

Station	7	7	8	8	9	9	13	13	14	14	16
Date	11/4/97	11/4/97	11/4/97	11/4/97	11/4/97	11/4/97	11/5/97	11/5/97	11/5/97	11/5/97	11/5/97
Time GMT	17:15	17:15	19:15	19:15	21:15	21:15	15:00	15:00	18:00	18:00	21:00
Latitude	32.545	32.545	32.401	32.401	32.239	32.239	31.092	31.092	31.065	31.065	31.018
Longitude	-79.625	-79.625	-79.484	-79.484	-79.339	-79.339	-78.193	-78.193	-78.203	-78.203	-78.237
TSS (mg/ml)	4.18	4.18	3.97	3.97	4.4	4.4	-9999	-9999	-9999	-9999	-9999
ChlF (mg/m ³)	0.341	0.341	0.23	0.23	0.22	0.22	-9999	-9999	0.164	0.164	0.181
ChlaHPLC (mg/m ³)	0.204	0.204	0.135	0.135	0.103	0.103	0.034	0.034	0.177	0.177	0.035
PRR File	k971104a1	k971104a2	k971104b1	k971104b2	k971104c1	k971104c2	k971105b1	k971105b2	k971105c1	k971105c2	k971105d2
Ed0-380	47.0810	56.4242	34.3683	33.0733	7.3309	7.4804	35.3895	42.3120	26.9404	25.6267	4.5353
Ed0-412	76.7952	90.6395	57.1641	56.9604	12.2554	11.7856	53.9924	65.1794	40.8128	43.3243	6.8204
Ed0-443	102.6940	109.4760	66.5370	70.7919	15.9260	17.1083	64.7101	74.7483	47.2889	50.4876	7.8016
Ed0-490	125.6110	126.9220	71.2410	80.5079	21.7360	20.9258	73.9974	93.9138	50.3702	46.6429	8.1409
Ed0-510	124.8870	127.2680	75.7468	81.9895	21.7361	20.5916	78.5806	81.7330	50.6077	46.1203	7.9294
Ed0-555	123.5110	113.0750	66.7596	79.9822	17.9951	19.7463	78.4282	82.2118	48.6075	44.3305	7.3616
Lu0-380	0.2971	0.4127	0.2223	0.2186	0.0756	0.0677	0.4627	0.4923	0.4368	0.3653	0.0686
Lu0-412	0.5430	0.6978	0.3948	0.3969	0.1278	0.1138	0.6740	0.7222	0.6021	0.4941	0.0948
Lu0-443	0.7327	0.9074	0.5184	0.5079	0.1572	0.1467	0.7076	0.7492	0.5965	0.4849	0.0920
Lu0-490	1.0542	1.3386	0.6911	0.6914	0.1979	0.1885	0.6489	0.6824	0.5237	0.4256	0.0809
Lu0-510	0.9935	1.5998	0.5604	0.5644	0.1580	0.1520	0.4429	0.4701	0.3588	0.2848	0.0541
Lu0-555	0.7218	0.9063	0.3298	0.3245	0.0912	0.0883	0.2127	0.2257	0.1629	0.1251	0.0229
Lu0-683	0.0904	0.3735	0.0379	0.0298	0.0092	0.0116	0.0214	0.0323	0.0112	0.0126	0.0032
Es0+380	57.1897	57.1481	40.4434	40.5187	10.4477	10.2019	42.4216	42.2595	41.0132	35.2875	7.8206

Es0+412	86.4812	86.3765	61.8463	62.0017	16.8132	16.2300	65.4077	64.3380	60.7748	51.0987	11.5609
Es0+443	103.2277	103.1189	73.7504	74.4762	20.7524	20.0114	78.4944	76.4406	70.3828	58.2816	13.2905
Es0+490	114.0841	113.9623	81.9425	83.2390	23.9840	22.9866	87.0858	83.9470	74.5485	60.5965	13.8472
Es0+510	116.1758	115.9848	84.2680	85.2182	24.9741	23.7184	89.0592	85.6235	74.9033	60.4028	13.6116
Es0+555	112.2040	111.9491	82.1636	82.3813	24.8535	23.0023	86.7828	83.1626	72.2169	57.6124	12.6920
Lwn380	0.2651	0.3685	0.2805	0.2753	0.3691	0.3384	0.5611	0.5945	0.7943	0.5282	0.4473
Lwn412	0.5791	0.7451	0.5888	0.5904	0.7010	0.6469	0.9581	1.0353	1.3063	0.8918	0.7567
Lwn443	0.7261	0.9002	0.7191	0.6976	0.7750	0.7497	0.9298	1.0027	1.2388	0.8511	0.7081
Lwn490	0.9664	1.2285	0.8822	0.8687	0.8631	0.8577	0.7857	0.8502	1.0439	0.7346	0.6112
Lwn510	0.8699	1.4030	0.6764	0.6736	0.6435	0.6521	0.5100	0.5585	0.6923	0.4796	0.4042
Lwn555	0.6440	0.8105	0.4019	0.3943	0.3675	0.3841	0.2474	0.2717	0.3221	0.2174	0.1806
k490	0.083	0.103	0.062	0.061	0.062	0.064	0.042	0.040	0.037	0.037	0.035
Es380Err	1.2%	1.0%	1.6%	1.0%	4.7%	4.3%	6.1%	1.6%	8.6%	3.1%	3.0%
Es412Err	1.4%	1.2%	1.9%	1.2%	4.7%	4.8%	7.3%	1.9%	10.3%	3.6%	3.1%
Es443Err	1.5%	1.3%	2.1%	1.3%	5.1%	5.8%	8.3%	2.0%	11.4%	3.9%	3.2%
Es490Err	1.6%	1.3%	2.3%	1.4%	6.7%	7.9%	9.5%	2.2%	12.7%	4.3%	3.2%
Es510Err	1.6%	1.3%	2.3%	1.4%	7.4%	9.0%	9.8%	2.3%	13.4%	4.4%	3.3%
Es555Err	1.6%	1.4%	2.4%	1.4%	9.0%	10.9%	10.4%	2.5%	14.2%	4.7%	3.4%
ds380	14%	-3%	11%	15%	27%	24%	13%	-4%	32%	24%	40%
ds412	8%	-9%	4%	4%	24%	24%	14%	-6%	30%	12%	39%
ds443	-4%	-11%	6%	1%	20%	11%	14%	-2%	30%	10%	39%
ds490	-15%	-16%	9%	-1%	6%	5%	11%	-17%	30%	20%	39%
ds510	-12%	-14%	6%	0%	9%	10%	8%	1%	30%	20%	39%
ds555	-15%	-5%	15%	-1%	25%	11%	6%	-3%	30%	20%	40%
Rrs490	0.0050	0.0063	0.0046	0.0045	0.0045	0.0044	0.0040	0.0044	0.0054	0.0038	0.0032
Rrs555	0.0035	0.0044	0.0022	0.0021	0.0020	0.0021	0.0013	0.0015	0.0017	0.0012	0.0010
X	0.1573	0.1617	0.3224	0.3240	0.3518	0.3299	0.4829	0.4763	0.4916	0.5098	0.5104
Expo	-0.0694	-0.0793	-0.4028	-0.4057	-0.4557	-0.4163	-0.6825	-0.6713	-0.6975	-0.7287	-0.7298
Expov2	-0.0347	-0.0434	-0.3391	-0.3419	-0.3885	-0.3518	-0.5917	-0.5822	-0.6042	-0.6298	-0.6307
ChlaOC2	0.8122	0.7931	0.3556	0.3529	0.3102	0.3434	0.1677	0.1732	0.1607	0.1468	0.1463
CZCSPigOC2	1.0929	1.0677	0.4864	0.4828	0.4255	0.4702	0.2329	0.2403	0.2233	0.2044	0.2037
K490MT	0.1076	0.1092	0.0689	0.0696	0.0599	0.0639	0.0399	0.0403	0.0394	0.0390	0.0389
MeasChla	0.204	0.204	0.135	0.135	0.103	0.103	0.034	0.034	0.177	0.177	0.035
sat/meas	3.9814	3.8876	2.6387	2.6188	3.0035	3.3252	4.9340	5.0947	0.9088	0.8301	4.2235
MeasPig	0.341	0.341	0.230	0.230	0.220	0.220	-9999	-9999	0.164	0.164	0.181
sat/meas	3.2051	3.1311	2.1148	2.0992	1.9342	2.1371	-9999	-9999	1.3618	1.2460	1.1255
k490sat/k490 meas	1.2910	1.0615	1.1100	1.1441	0.9617	1.0003	0.9519	1.0004	1.0765	1.0410	1.1048
OC2v2	0.8302	0.8121	0.3651	0.3622	0.3159	0.3520	0.1631	0.1688	0.1559	0.1416	0.1412
OC2v2/ChlF	2.4346	2.3814	1.5874	1.5747	1.4359	1.5998	0.0000	0.0000	0.9505	0.8636	0.7799
OC2v2/HPLC	4.0694	3.9805	2.7095	2.6879	3.0584	3.4077	4.7996	4.9666	0.8817	0.8011	4.0753

D. Backscattering Data

Spectral backscattering coefficients varied across wavelength and between oceanographic regimes (see Appendix E). In all cases the lower wavelengths had higher coefficients and the coefficients decreased with increasing wavelength. Coefficients in near-shore waters tended to be higher and more variable with depth. Stations in the Sargasso Sea showed

little variation with depth. Stray light appears to affect measurements within the first 1 – 3m in some cases.

E. SeaWiFS-Derived Data

Features in the SeaWiFS ocean color image (Figure 6) reveal that the physical oceanographic features affect the phytoplankton pigment concentrations. An eddy is visible as an increase in pigment between 60 and 110 km offshore that can be seen in the the surface chl fluorescence (Figure 4) and HPLC data (Figure 5) can also be seen in the ocean color image. The image indicates that the type of variability in pigment concentrations that is caused by eddy intrusions are evident across the continental shelf.

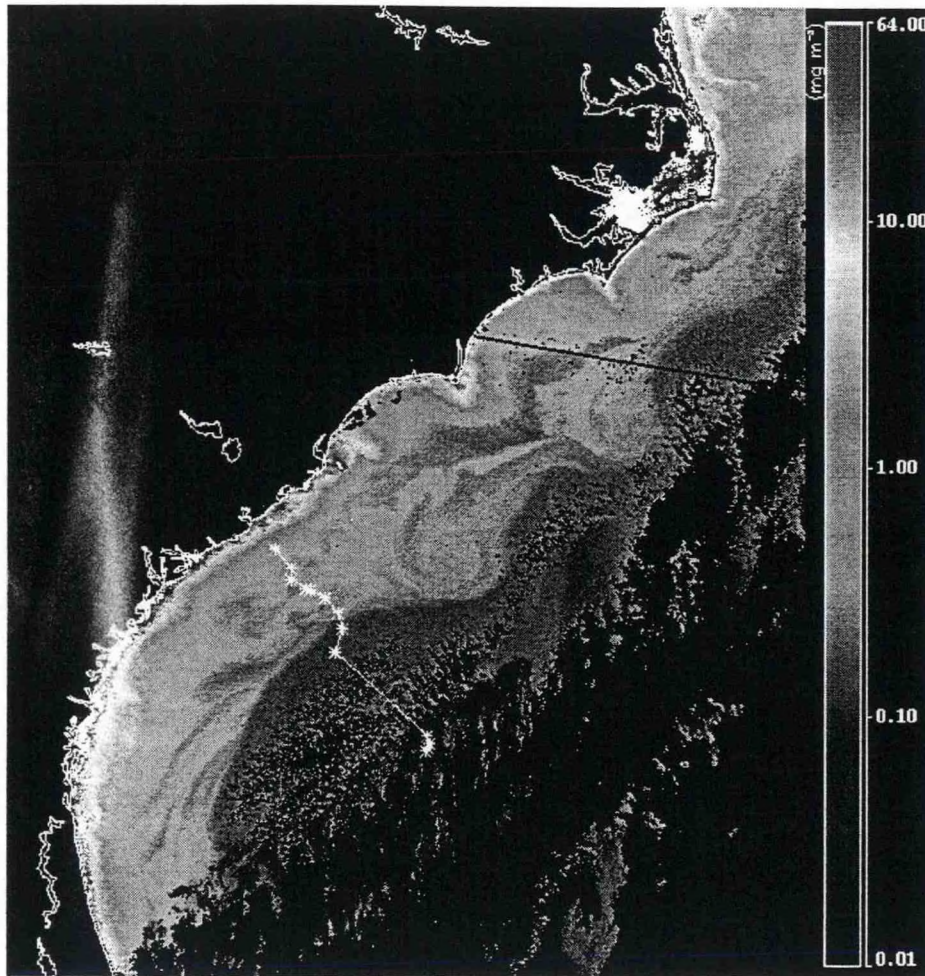

Figure 6. SeaWiFS pigment image for November 4, 1997.

Cruise track and stations shown in white.

A comparison of the *in-situ* optical measurements and the satellite derived normalized water leaving radiance is shown in Figure 7. The *in-situ* measurements at stations 7 and 8 were made within two hours of the over pass and at station 9 within four hours. The

overestimation of the *in-situ* water leaving radiance at station 7 could be due to either perturbations at the surface or due to the proximity to the coastal front. However, station 8 and station 9 show that the *in-situ* observations are in good agreement with the satellite. A comparison of the pigment concentrations measured by satellite and by *in situ* methods is shown in Table 5. *In situ* measurements are lower than satellite concentrations nearshore where colored dissolved organic matter and suspended sediments may complicate satellite ocean color algorithms. Offshore, satellite measurements more closely match those measured *in situ*. This lack of agreement may be due to algorithm failure or by a lack of spatial and temporal coincidence because of the difference in time of the *in situ* measurement and the satellite image. This type of variability complicates the evaluation of satellite algorithms to accurately detect pigment concentrations in coastal waters.

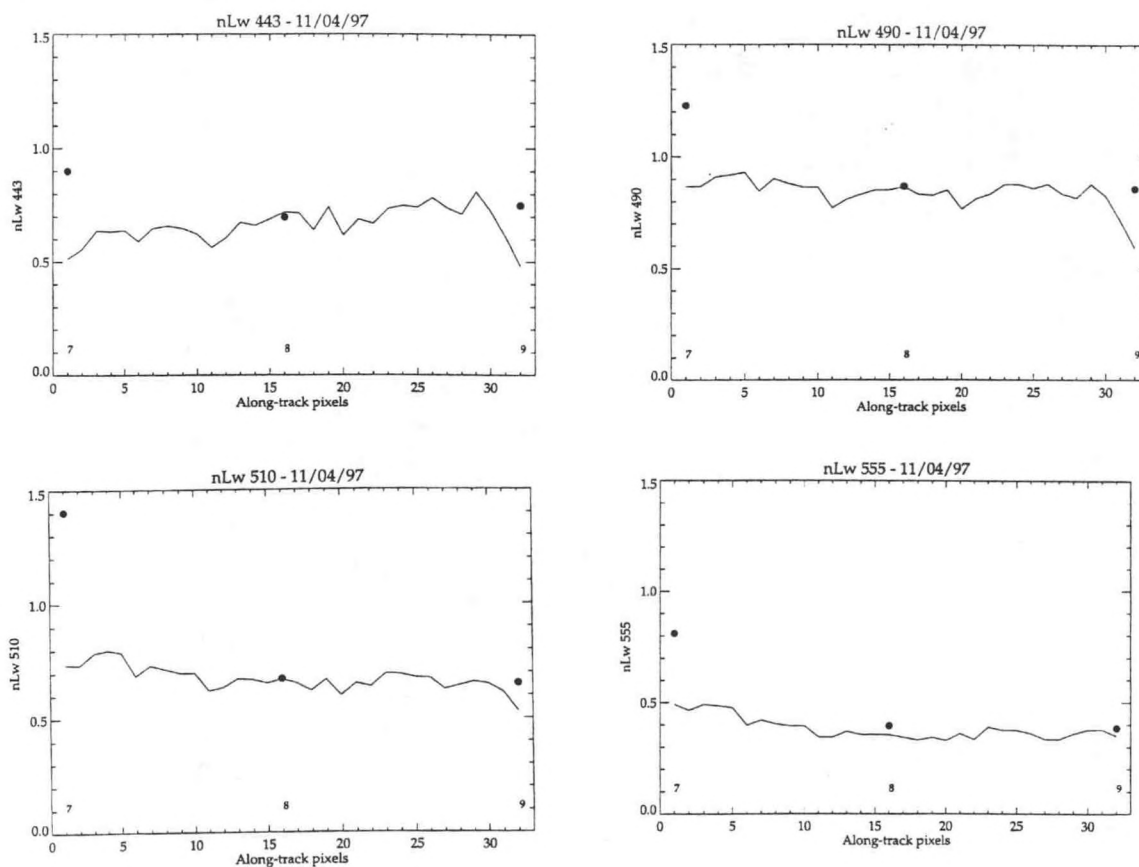

Figure 7. Comparison of *in-situ* and SeaWiFS derived normalized water leaving radiance

Table 5. SeaWiFS image chl *a* concentrations, corresponding *in situ* chl *a* from fluorometric and HPLC analysis, and the OC2 algorithm.

Date	Station	Latitude	Longitude	PRRFile	Flu Chl <i>a</i>	HPLC Chl <i>a</i>	OC2 Chl <i>a</i>	SeaWiFS Chl <i>a</i>
11/4/97	7	32.543	-79.616	971104A1	0.341	0.204	0.812	0.729
11/4/97	7	32.543	-79.616	971104A2	0.341	0.204	0.793	0.729
11/4/97	8	32.399	-79.476	971104B1	0.230	0.135	0.356	0.288
11/4/97	8	32.399	-79.476	971104B2	0.230	0.135	0.353	0.288
11/4/97	9	32.240	-79.336	971104C1	0.220	0.103	0.310	0.464
11/4/97	9	32.240	-79.336	971104C2	0.220	0.103	0.343	0.464
11/5/97	13	31.075	-78.198	971105B1	N/A	0.034	0.168	N/A
11/5/97	13	31.075	-78.198	971105B2	N/A	0.034	0.173	N/A
11/5/97	14	31.061	-78.205	971105C1	0.164	0.177	0.159	N/A
11/5/97	14	31.061	-78.205	971105C2	0.164	0.177	0.147	N/A
11/5/97	16	31.019	-78.235	971105D1	0.181	0.035	0.165	N/A
11/5/97	16	31.019	-78.235	971105D2	0.181	0.035	0.146	N/A

V. Summary

The results of this cruise show that the OC2 algorithm works reasonably well in stations further off-shore although in general the algorithm tends to over-predict chlorophyll concentrations in coastal waters. Also we found surprisingly good agreement between our *in-situ* optical measurements of normalized water-leaving radiance and that measured by the SeaWiFS sensor. We interpret this to mean that our *in-situ* measurements are of good quality and that our goal of validating satellite chlorophyll algorithms using these measurements is reasonable and tractable.

VI. References

O'Reilly, J. E., S. Maritorena, B. G. Mitchell, D. A. Siegel, K. L. Carder, S. A. Garver, and C. R. McClain, 1998. Ocean color chlorophyll algorithms for SeaWiFS. *Journal of Geophysical Research*, submitted.

Phinney, D.A. and C.S. Yentsch, 1991. On the contribution of particles to blue light attenuation in the sea. *Journal of Plankton Research*, **13**, Supplement, 143-152.

Siegel, D. A., M. C. O'Brien, J. C. Sorensen, D. A. Konnoff and E. Fields (1995). BBOP Data Processing and Sampling Procedures. **Vol: 19**, Institute for Computational Earth System Science, UC Santa Barbara, Santa Barbara, CA, 23 pp.

Wright, S. W., S. W. Jeffrey, R. F. C Mantoura, C. A. Llewellyn, T. Bjornland, D. Repeta, and N. Welschmeyer, 1991. Improved HPLC method for the analysis of chlorophylls and carotenoids from marine phytoplankton. *Marine Ecology Progress Series*, **77**, 183-196.

Yentsch, C.S. and D.W. Menzel, 1963. A method for determination of phytoplankton chlorophyll and phaeophytin by fluorescence. *Deep Sea Research*, **10**, 221-231.

Yentsch, C.S. and D.A. Phinney, 1989. A bridge between ocean optics and microbial ecology. *Limnology and Oceanography*. **34**: 1698-1709.

VII. Metadata

The core documentation section is designed for the purposes of the Coastal Information Directory (CID). The metadata in this section is used in building the CID's database.

Identification Information:

Citation:

Citation Information:

Originator: Ajit Subramaniam, REMSA, NOAA Coastal Services Center

Originator: Mary E. Culver, TPMC, NOAA Coastal Services Center

Originator: John C. Brock, U.S. Geological Survey, Center for Coastal Geology

Originator: Mark E. Geesey, REMSA, NOAA Coastal Services Center

Originator: Giacomo R. DiTullio, Grice Marine Lab, College of Charleston

Originator: David Jones, Grice Marine Lab, College of Charleston

Publication Date: 199809

Title: NOAA CSC/CRS Cruise NOV97SAR: Sargasso Sea Cruise

Geospatial Data Presentation Form: profile

Series Information:

Series Name: CSC Technical Report
Issue Identification: CSC/9-98/001
Publication Information:
Publication Place: Charleston, South Carolina
Publisher: NOAA Coastal Services Center
Online Linkage: <http://www.csc.noaa.gov/crs/cruises/SCROL.html>

Description:

Abstract: See page iii.

Purpose: See page 6.

Time Period of Content:

Time Period Information:

Range of Dates/Times:

Beginning Date: 19971103

Ending Date: 19971105

Currentness Reference: Publication Date

Status:

Progress: Complete

Maintenance and Update Frequency: Unknown

Spatial Domain:

Bounding Coordinates:

West Bounding Coordinate: -79.625

East Bounding Coordinate: -78.193

North Bounding Coordinate: 32.545

South Bounding Coordinate: 31.018

Keywords:

Theme:

Theme Keyword Thesaurus: None

Theme Keyword: oceanography

Theme Keyword: bio-optical

Theme Keyword: turbidity

Theme Keyword: water clarity

Theme Keyword: algal blooms

Theme Keyword: coastal water optics

Theme Keyword: case II algorithms

Theme Keyword: light attenuation

Theme Keyword: reflectance difference

Theme Keyword: in-situ optical profiling

Theme Keyword: ocean color satellites

Theme Keyword: coastal ocean algorithm development

Theme Keyword: downwelling irradiance

Theme Keyword: upwelling radiance

Theme Keyword: temperature

Theme Keyword: chlorophyll

Theme Keyword: particulate absorption

Theme Keyword: colored dissolved organic matter

Theme Keyword: salinity
Theme Keyword: spectral attenuation
Theme Keyword: spectral absorption
Theme Keyword: beam attenuation
Theme Keyword: quantum irradiance
Theme Keyword: light scattering
Theme Keyword: fluorescence

Place:

Place Keyword Thesaurus: None
Place Keyword: Sargasso Sea
Place Keyword: South Atlantic Bight
Place Keyword: South Carolina
Place Keyword: United States
Place Keyword: Gulf Stream

Temporal:

Temporal Keyword Thesaurus: None
Temporal Keyword: Fall
Temporal Keyword: November, 1997

Access Constraints: None

Use Constraints: **See page v.**

Point of Contact:

Contact Information:

Contact Organization Primary:
Contact Organization: NOAA Coastal Services Center
Contact Address:
Address Type: mailing and physical address
Address: 2234 Hobson Avenue
City: Charleston
State or Province: South Carolina
Postal Code: 29405-2413
Country: USA
Contact Voice Telephone: (843) 740-1200
Contact Facsimile Telephone: (843) 740-1224
Contact Electronic Mail Address: csc@csc.noaa.gov
Hours of Service: 8AM-5PM, M-F

Data Set Credit:

Data Quality Information:

Attribute Accuracy:

Attribute Accuracy Report: The instrumentation used on the cruise are sent to the respective manufacturers for calibration at least once per year. Calibration certificates for the relevant instrumentation are available in the full written report.

Logical Consistency Report: See Methods Section, pp 12-13.

Completeness Report: Refer to the separate sections of Logical Consistency, Methodology, and Process Steps for descriptions of completeness of the data.

Lineage:

Methodology: See Methods Section pp 6-13.

Process Step:

Process Description: Calibration of the Biospherical Instruments QSP200 Quantum Scalar Radiometer.

Process Date: 19970210

Process Contact:

Contact Information:

Contact Organization Primary:

Contact Organization: Biospherical Instruments, Inc.

Contact Address:

Address Type: mailing and physical address

Address: 5340 Riley Street

City: San Diego

State or Province: California

Postal Code: 92110-2621

Country: USA

Contact Voice Telephone: (619) 686-1888

Process Step:

Process Description: Calibration of the Biospherical PRV-600s PRR Spectroradiometer.

Process Date: 19970210

Process Contact:

Contact Information:

Contact Organization Primary:

Contact Organization: Biospherical Instruments, Inc.

Contact Address:

Address Type: mailing and physical address

Address: 5340 Riley Street

City: San Diego

State or Province: California

Postal Code: 92110-2621

Country: USA

Contact Voice Telephone: (619) 686-1888

Process Step:

Process Description: Calibration of the Biospherical PRV610 PRR Spectroradiometer.

Process Date: 19970210

Process Contact:

Contact Information:

Contact Organization Primary:

Contact Organization: Biospherical Instruments, Inc.

Contact Address:

Address Type: mailing and physical address

Address: 5340 Riley Street

City: San Diego
State or Province: California
Postal Code: 92110-2621
Country: USA
Contact Voice Telephone: (619) 686-1888

Process Step:

Process Description: Calibration of the Hydrosocat6 in situ Backscattering Sensor.

Process Date: 19970527

Process Contact:

Contact Information:

Contact Organization Primary:

Contact Organization: HOBI Labs

Contact Address:

Address Type: mailing and physical address

Address: 55 Penny Lane, Suite 104

City: Watsonville

State or Province: California

Postal Code: 95076-6017

Country: USA

Contact Voice Telephone: (408) 768-0680

Process Step:

Process Description: Calibration of the Hydrolabs Datasonde-3 turbidity, conductivity, pH, DO, temperature probe.

Process Date: 19980108

Process Contact:

Contact Information:

Contact Organization Primary:

Contact Organization: Hydrolab Corporation

Contact Address:

Address Type: physical

Address: 12921 Burnet Road

City: Austin

State or Province: Texas

Postal Code: 78727

Country: USA

Contact Voice Telephone: (800) 949-3766

Process Step:

Process Description: Calibration of the SeaTech C660 Transmissometer.

Process Date: 1995

Process Contact:

Contact Information:

Contact Organization Primary:

Contact Organization: Sea Tech, Inc.

Contact Address:

Address Type: mailing and physical address

Address: 825 NE Circle Blvd.
City: Corvallis
State or Province: Oregon
Postal Code: 97330
Country: USA
Contact Voice Telephone: (206) 757-9716

Process Step:

Process Description: Calibration of the SeaTech LSS Light Scattering Sensor.

Process Date: 1995

Process Contact:

Contact Information:

Contact Organization Primary:

Contact Organization: Sea Tech, Inc.

Contact Address:

Address Type: mailing and physical address

Address: 825 NE Circle Blvd.

City: Corvallis

State or Province: Oregon

Postal Code: 97330

Country: USA

Contact Voice Telephone: (541) 757-9716

Process Step:

Process Description: Calibration of the SAFire Spectral Absorption and Fluorescence Instrument.

Process Date: 19951208

Process Contact:

Contact Information:

Contact Organization Primary:

Contact Organization: WET Labs, Inc.

Contact Address:

Address Type: mailing and physical address

Address: 620 Applegate Street

City: Philomath

State or Province: Oregon

Postal Code: 97370

Country: USA

Contact Voice Telephone: (541) 929-5650

Process Step:

Process Description: Calibration of the WetStar in situ Fluorometer

Process Date: 1998

Process Contact:

Contact Information:

Contact Person Primary:

Contact Person: A. Subramaniam

Contact Organization: NOAA Science Center

Contact Address:

Address Type: mailing and physical address
Address: 4700 Silver Hill Road, Stop 9910
City: Washington
State or Province: District of Columbia
Postal Code: 20233-9910
Country: USA
Contact Voice Telephone: (800) 789-2234

Spatial Data Organization Information:

Indirect Spatial Reference: South Atlantic Bight, South Carolina, USA, Gulf Stream, Sargasso Sea

Distribution Information:

Distributor:

Contact Information:

Contact Organization Primary:
Contact Organization: NOAA Coastal Services Center
Contact Address:
Address Type: mailing and physical address
Address: 2234 Hobson Avenue
City: Charleston
State or Province: South Carolina
Postal Code: 29405-2413
Country: USA
Contact Voice Telephone: (843) 740-1200
Contact Facsimile Telephone: (843) 740-1224
Contact Electronic Mail Address: csc@csc.noaa.gov
Hours of Service: 8AM-5PM, M-F

Resource Description: NOV97SAR Cruise Report

Distribution Liability: None

Custom Order Process: Contact the distributor for a paper copy of the technical report, or the data can be accessed on-line at <http://www.csc.noaa.gov/crs/cruises/>.

Metadata Reference Information:

Metadata Date: 19980929

Metadata Review Date: 19981001

Metadata Contact:

Contact Information:

Contact Organization Primary:
Contact Organization: NOAA, Coastal Services Center
Contact Position: Metadata Specialist
Contact Address:
Address Type: mailing and physical address
Address: 2234 Hobson Avenue

City: Charleston

State or Province: South Carolina

Postal Code: 29405-2413

Country: USA

Contact Voice Telephone: (843) 740-1200

Contact Facsimile Telephone: (843) 740-1224

Contact Electronic Mail Address: csc@csc.noaa.gov

Hours of Service: 8AM-5PM, M-F

Metadata Standard Name: Content Standard for National Biological Information Infrastructure Metadata.

Metadata Standard Version: December 1995

VIII. Appendix A - Water Column Profile Data Figures

Figure A.1.a - Station 7 Downcast

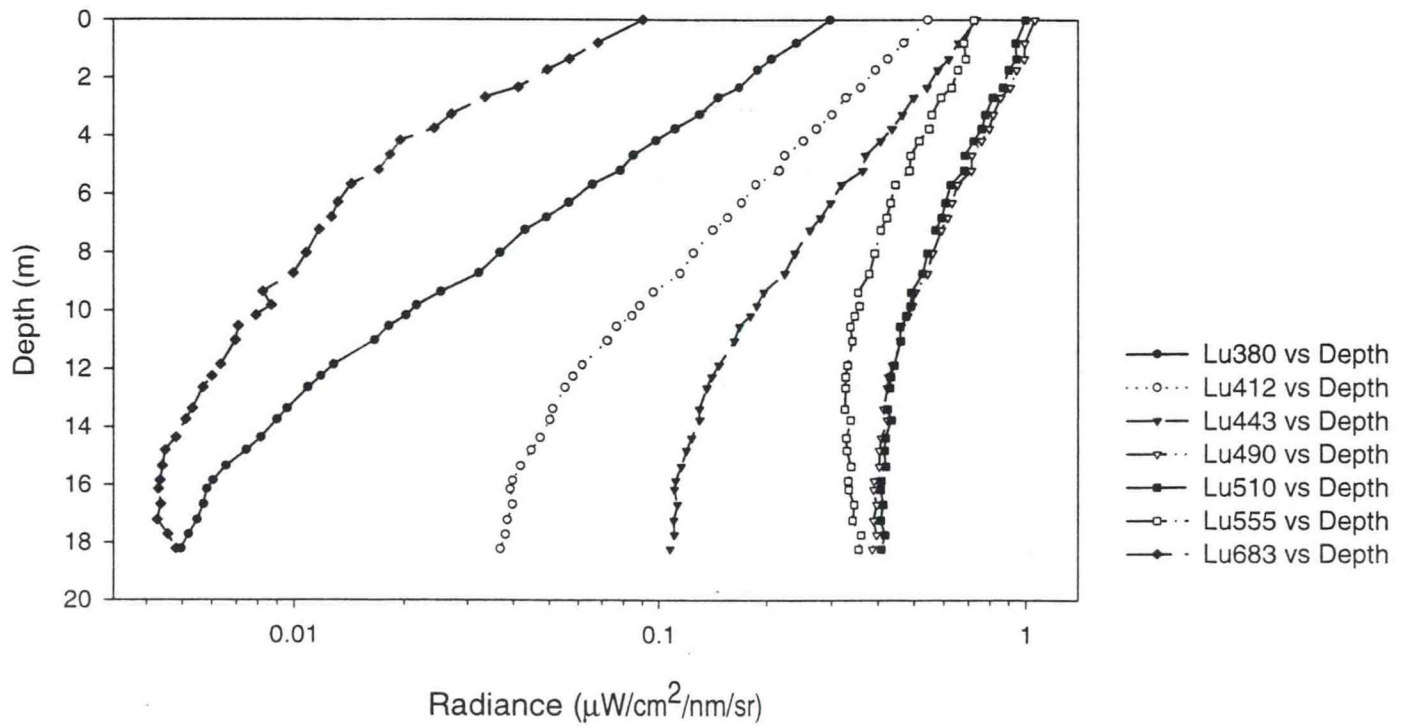
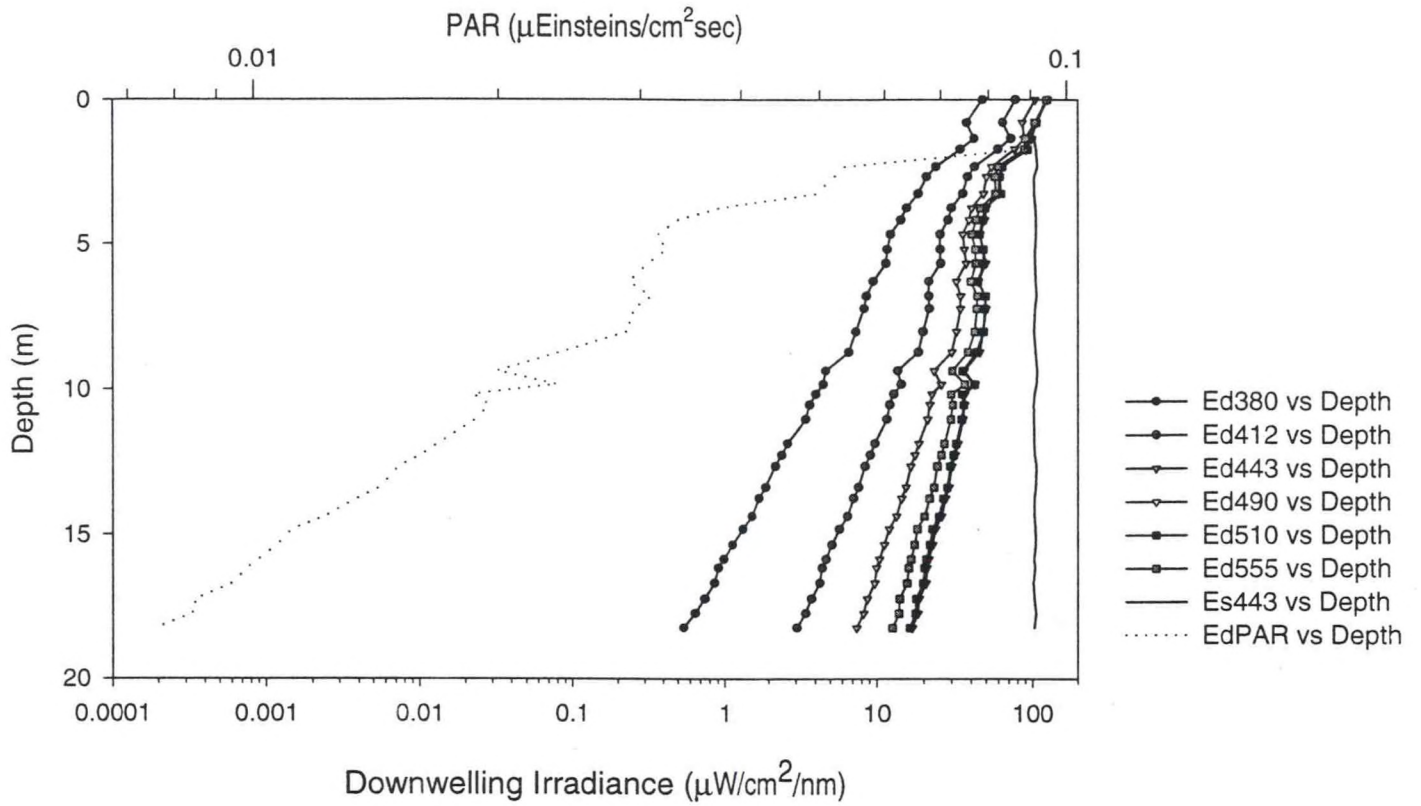
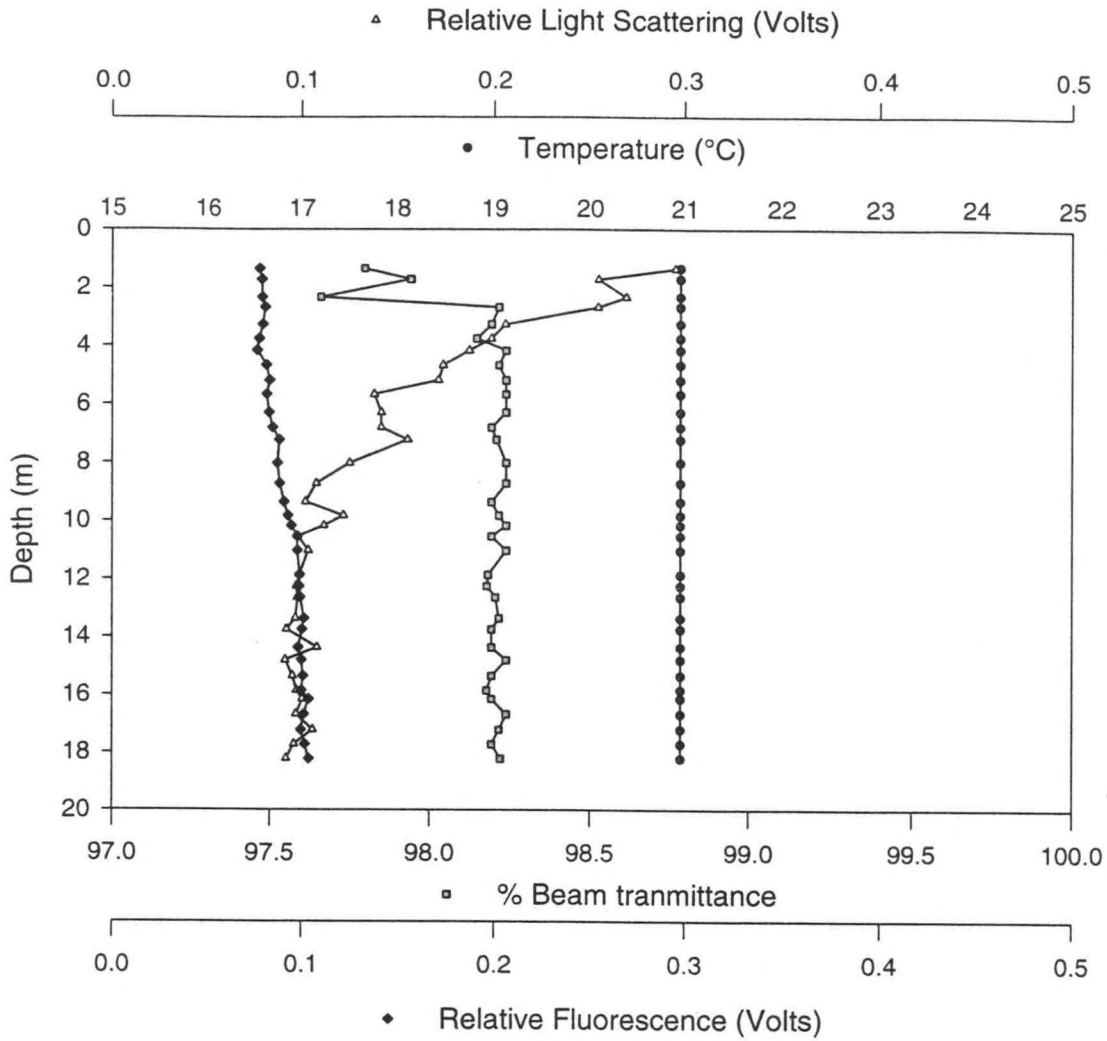

Figure A.1.b - Station 7 Downcast



Diffuse Attenuation Coefficient (k_{λ})

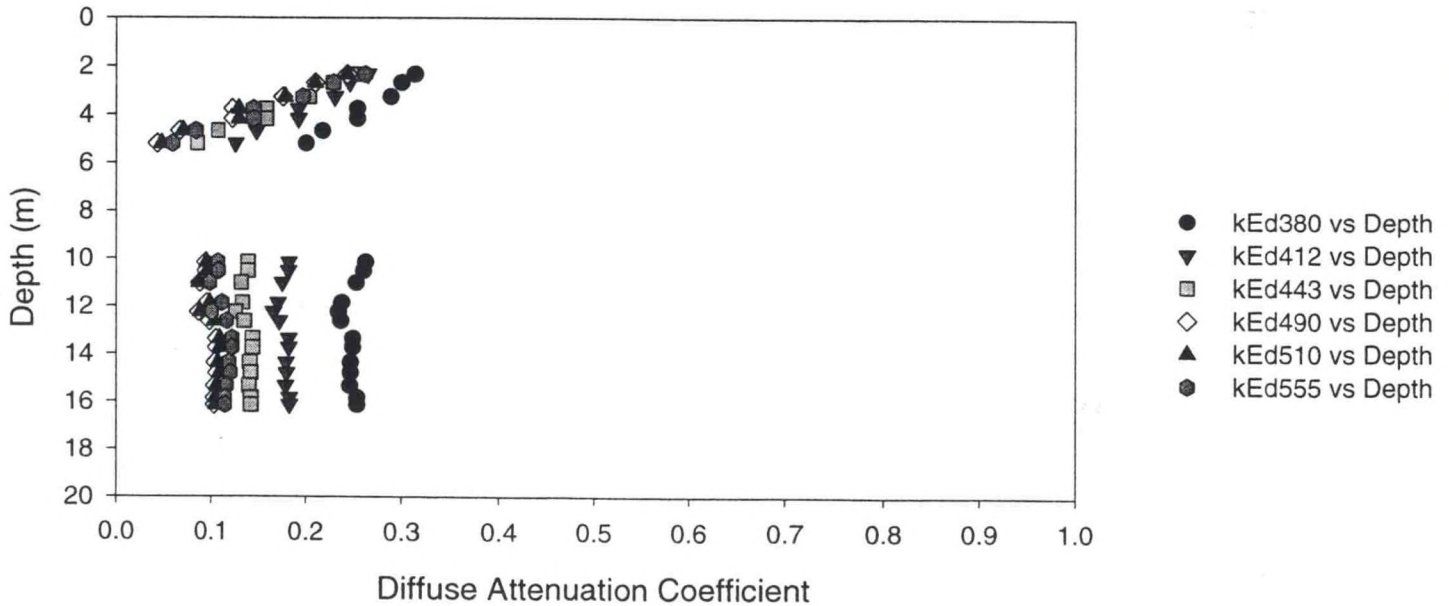

Figure A.2.a - Station 7 Upcast

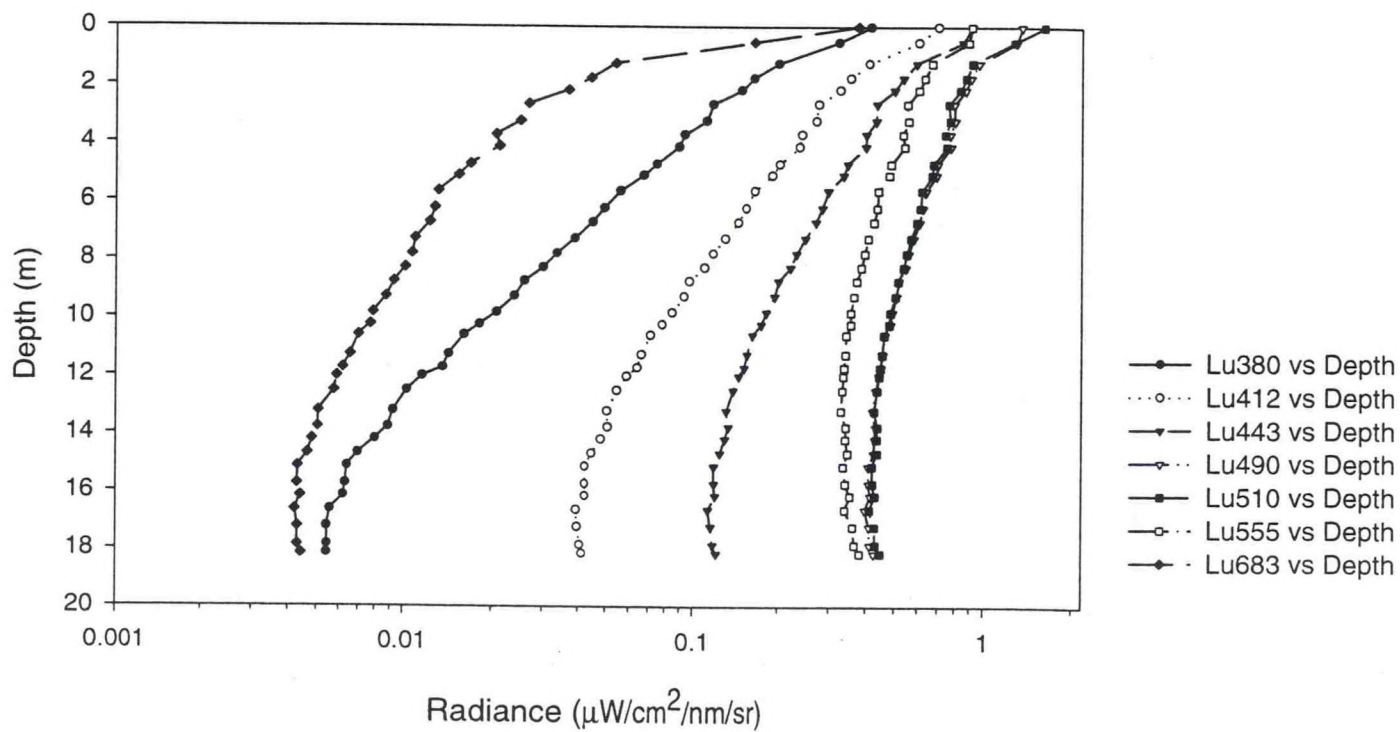
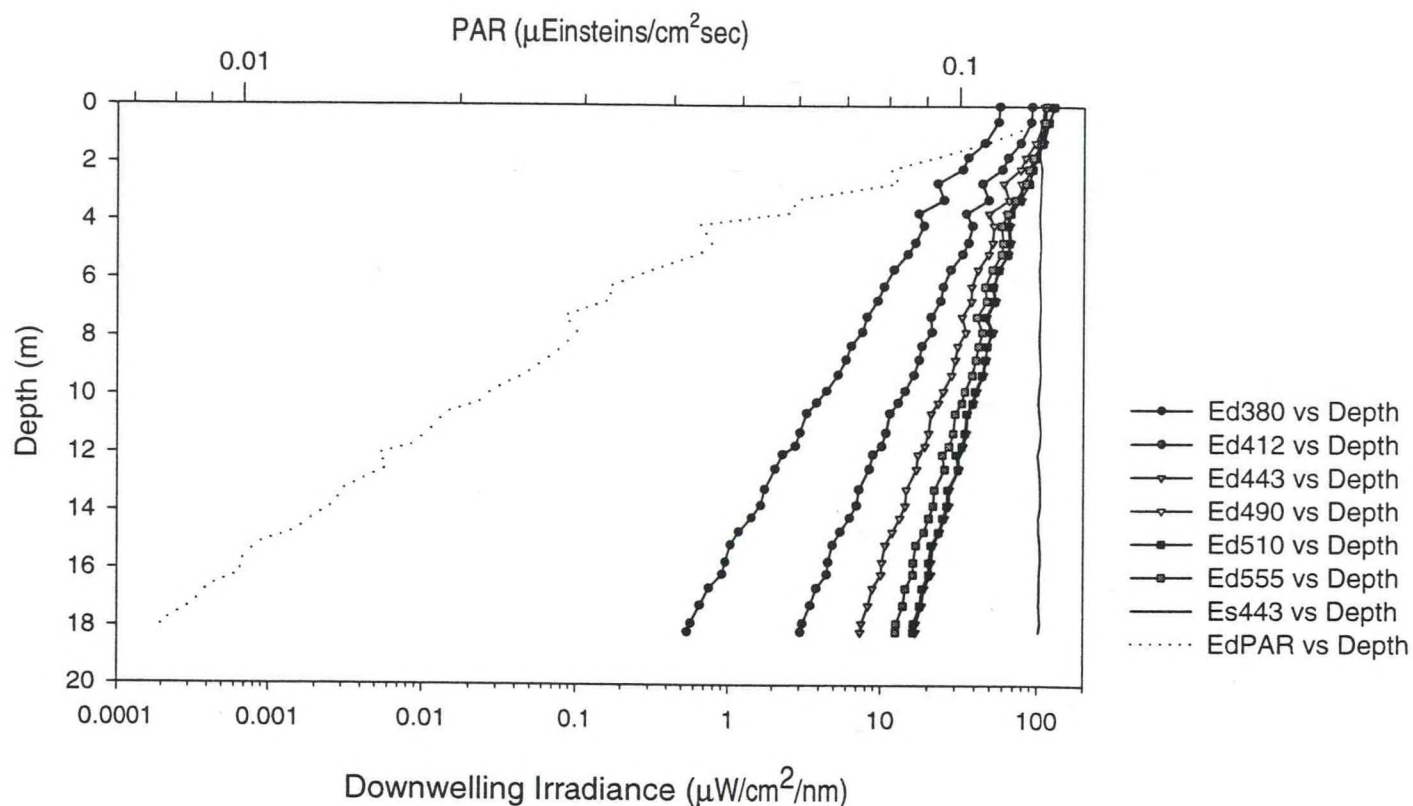
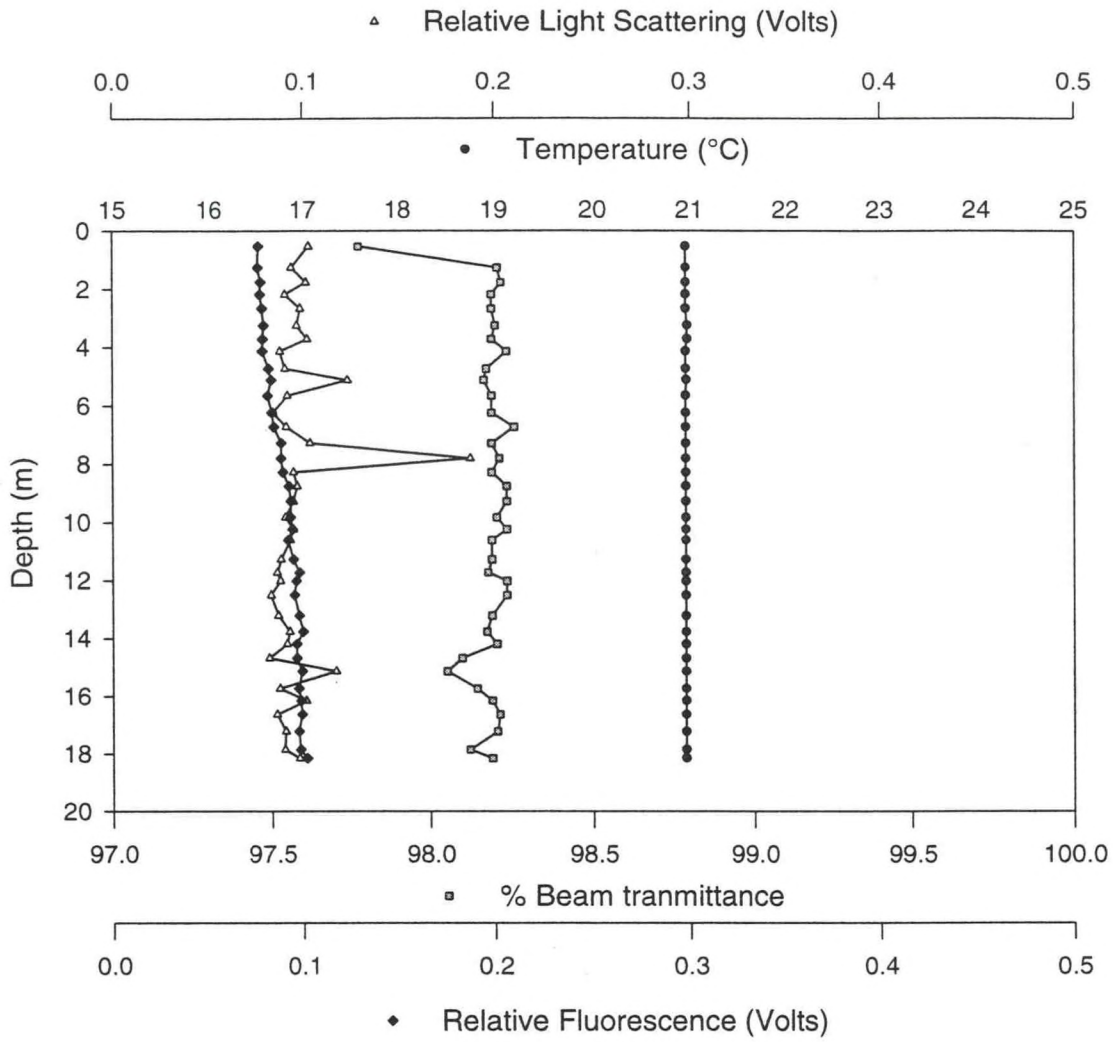

Figure A.2.b - Station 7 Upcast



Diffuse Attenuation Coefficient (k_λ)

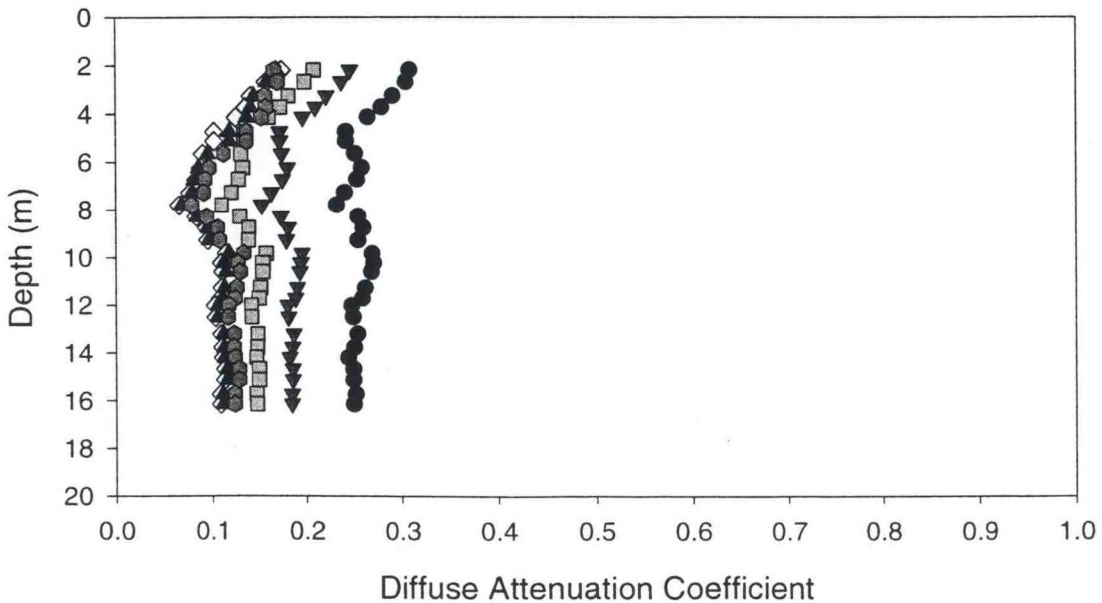

Figure A.3.a - Station 8 Downcast

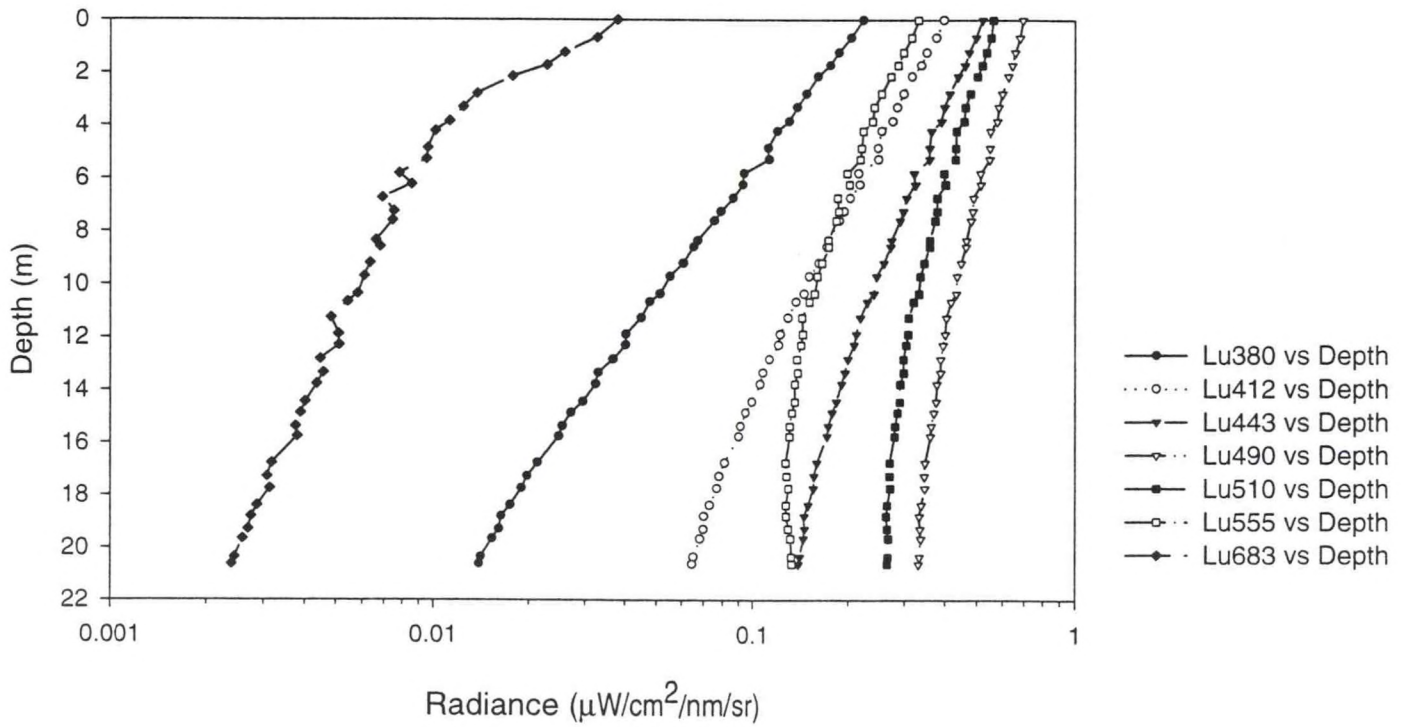
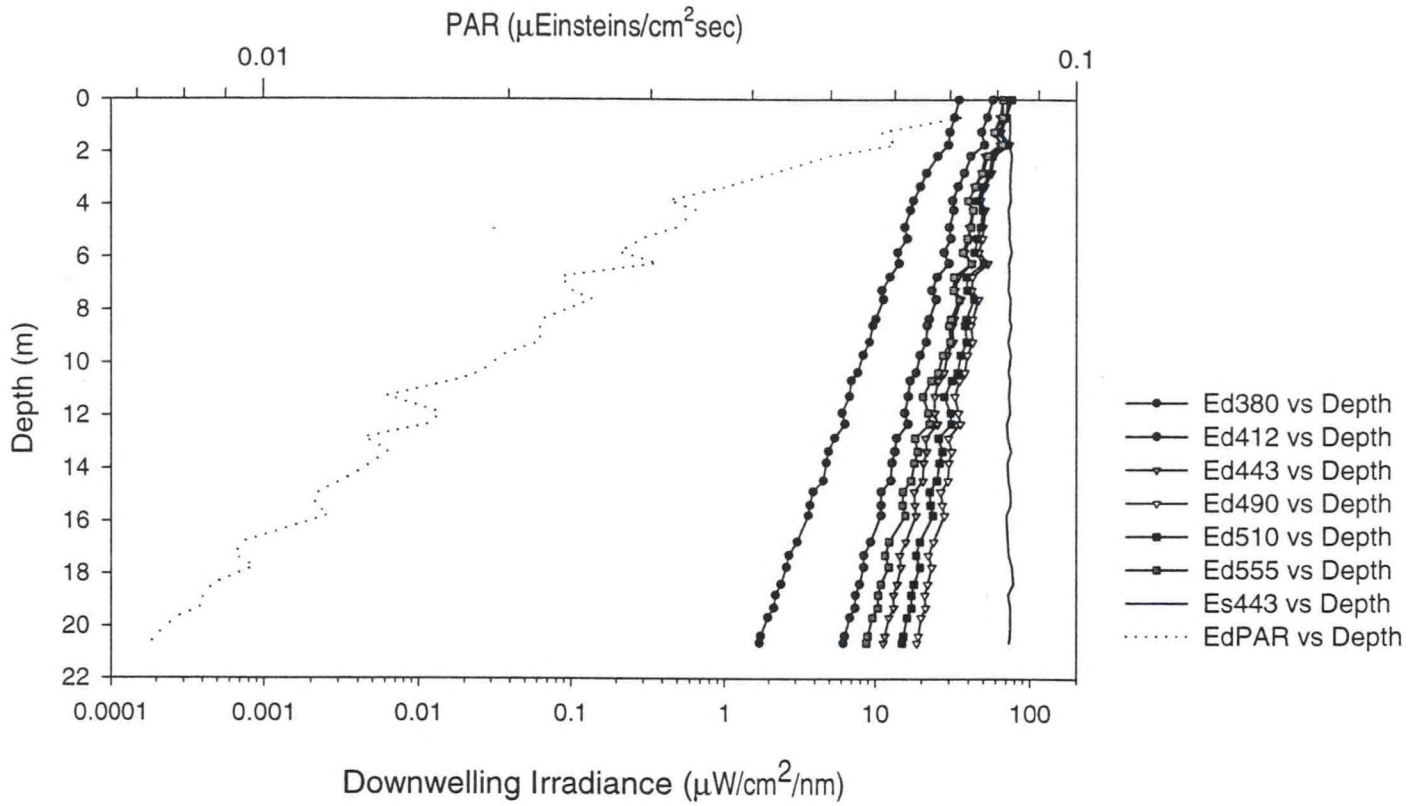
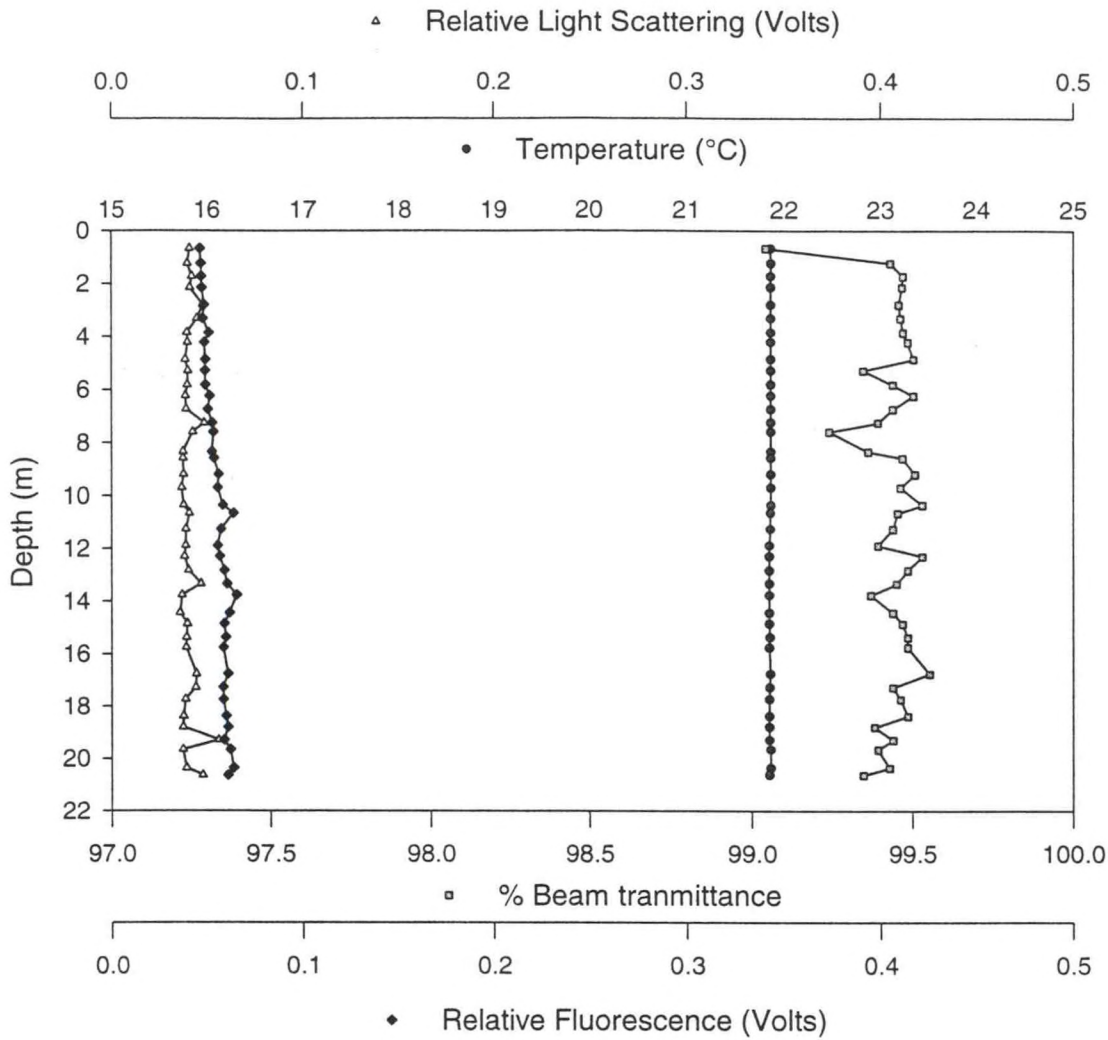

Figure A.3.b - Station 8 Downcast



Diffuse Attenuation Coefficient (k_λ)

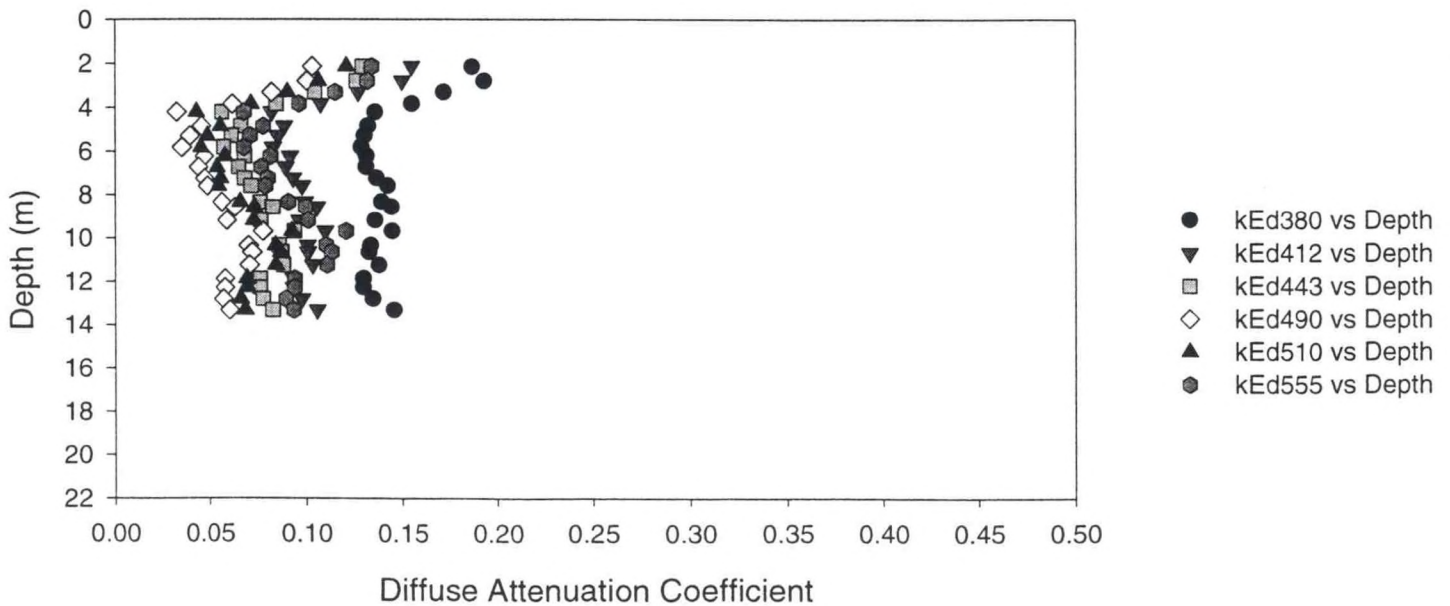

Figure A.4.a - Station 8 Upcast

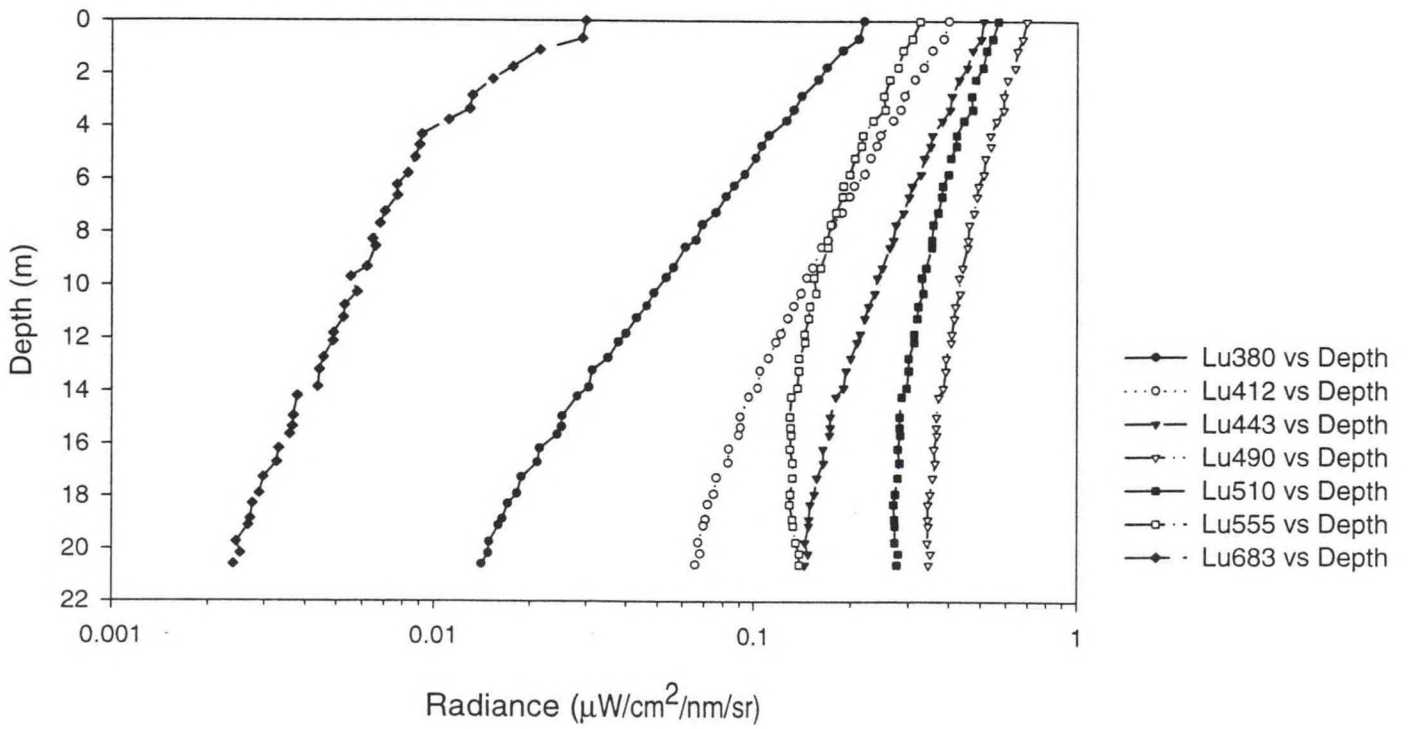
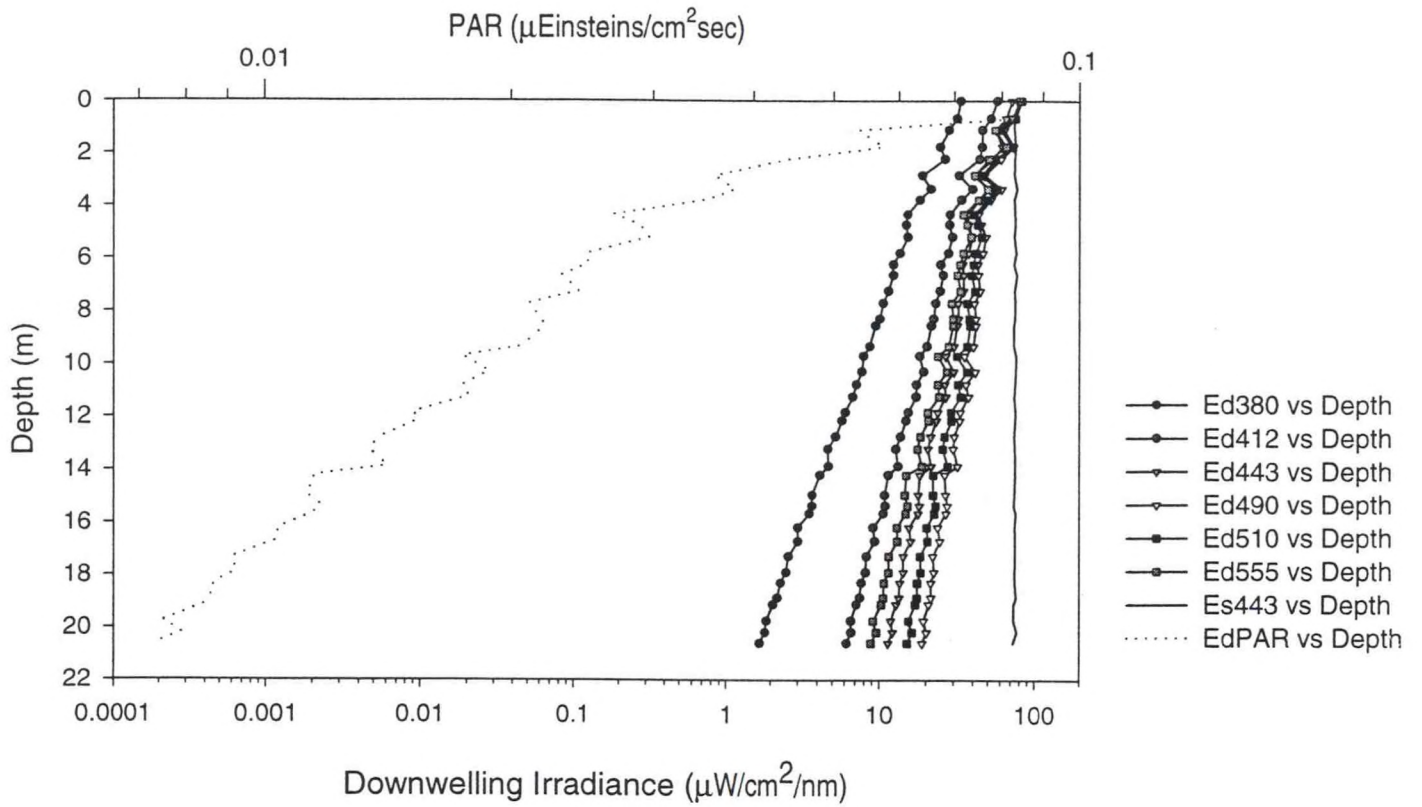
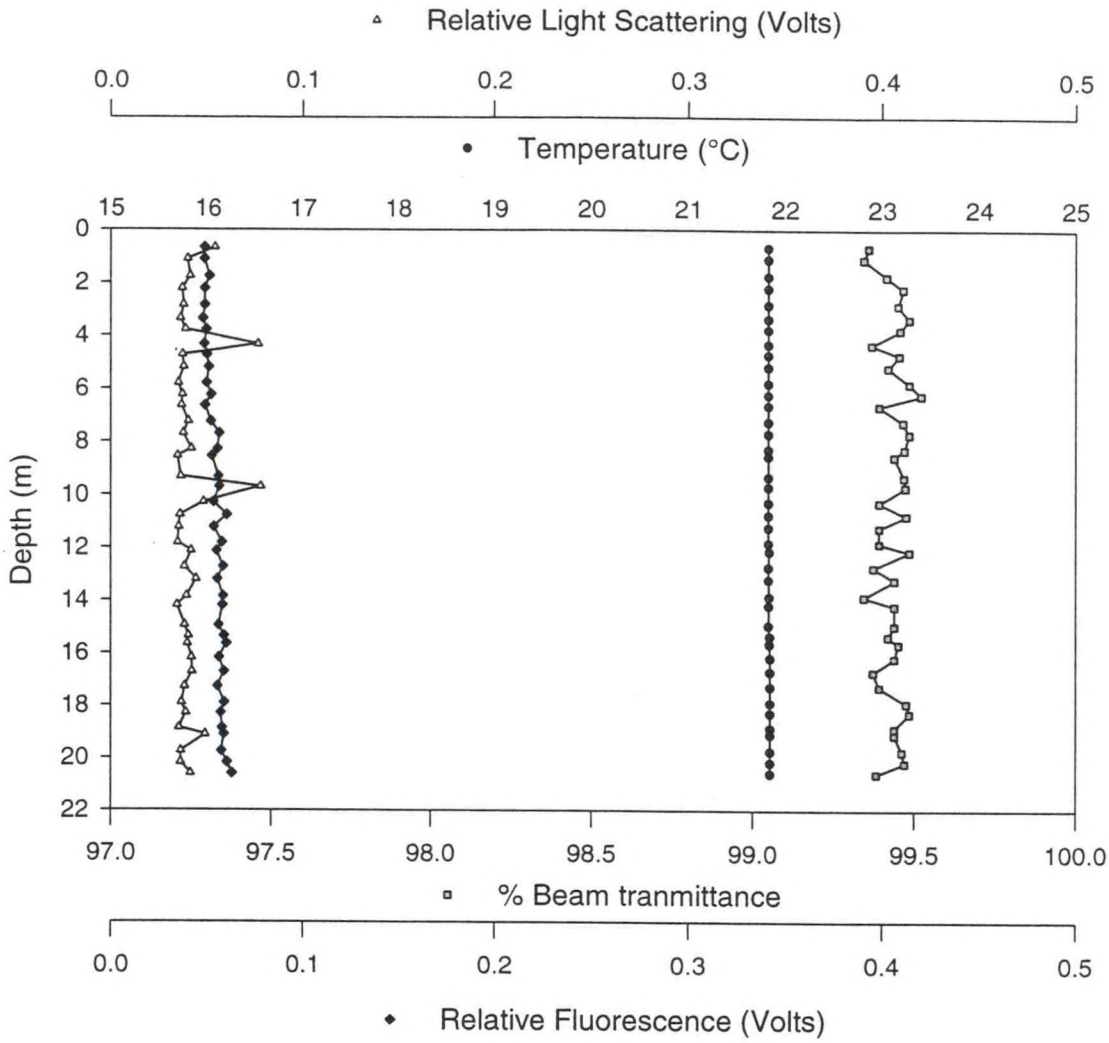

Figure A.4.b - Station 8 Upcast



Diffuse Attenuation Coefficient (k_λ)

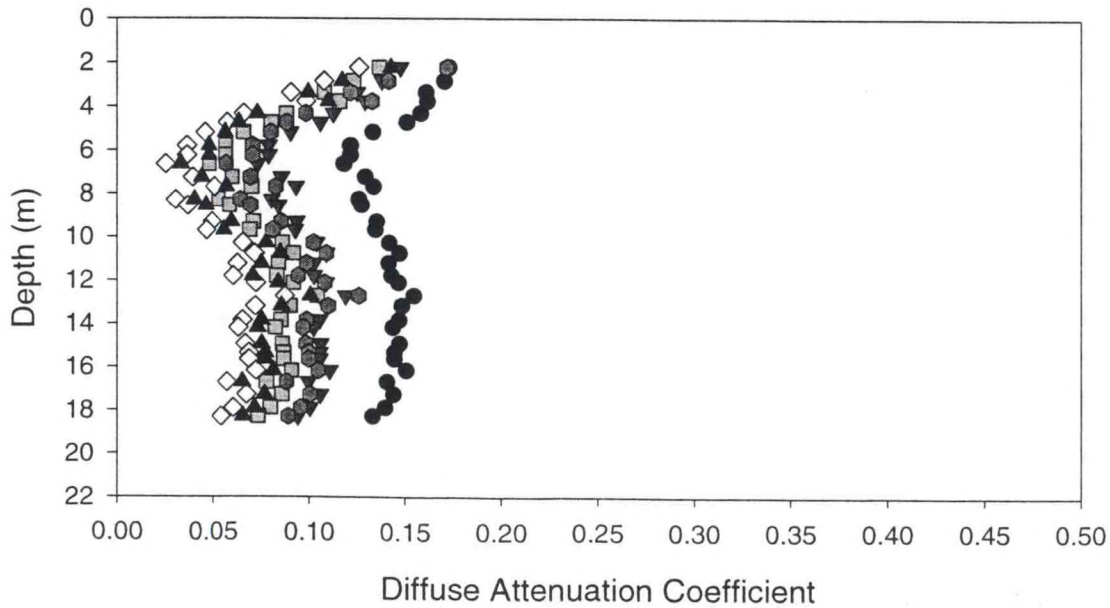

Figure A.5.a - Station 9 Downcast

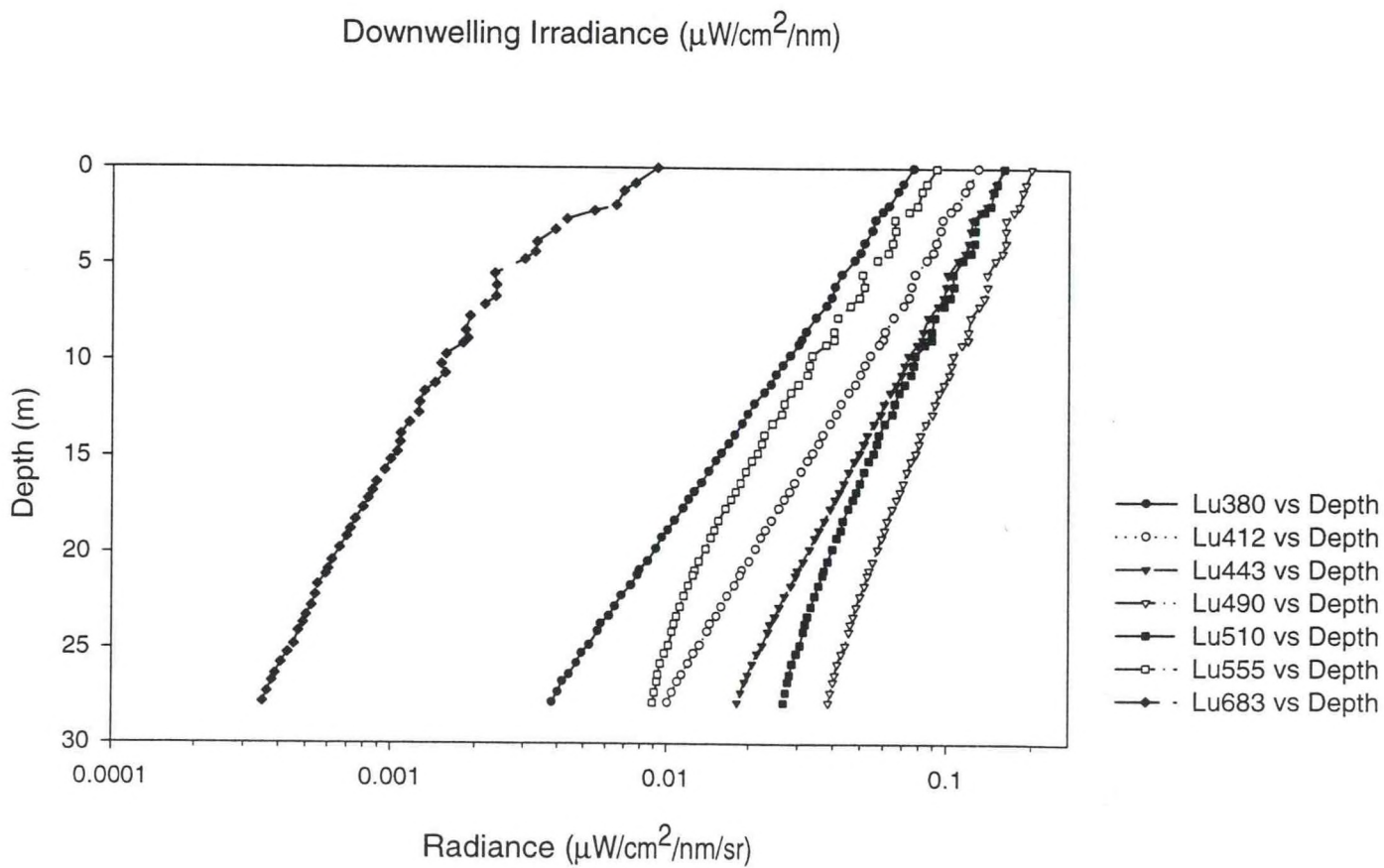
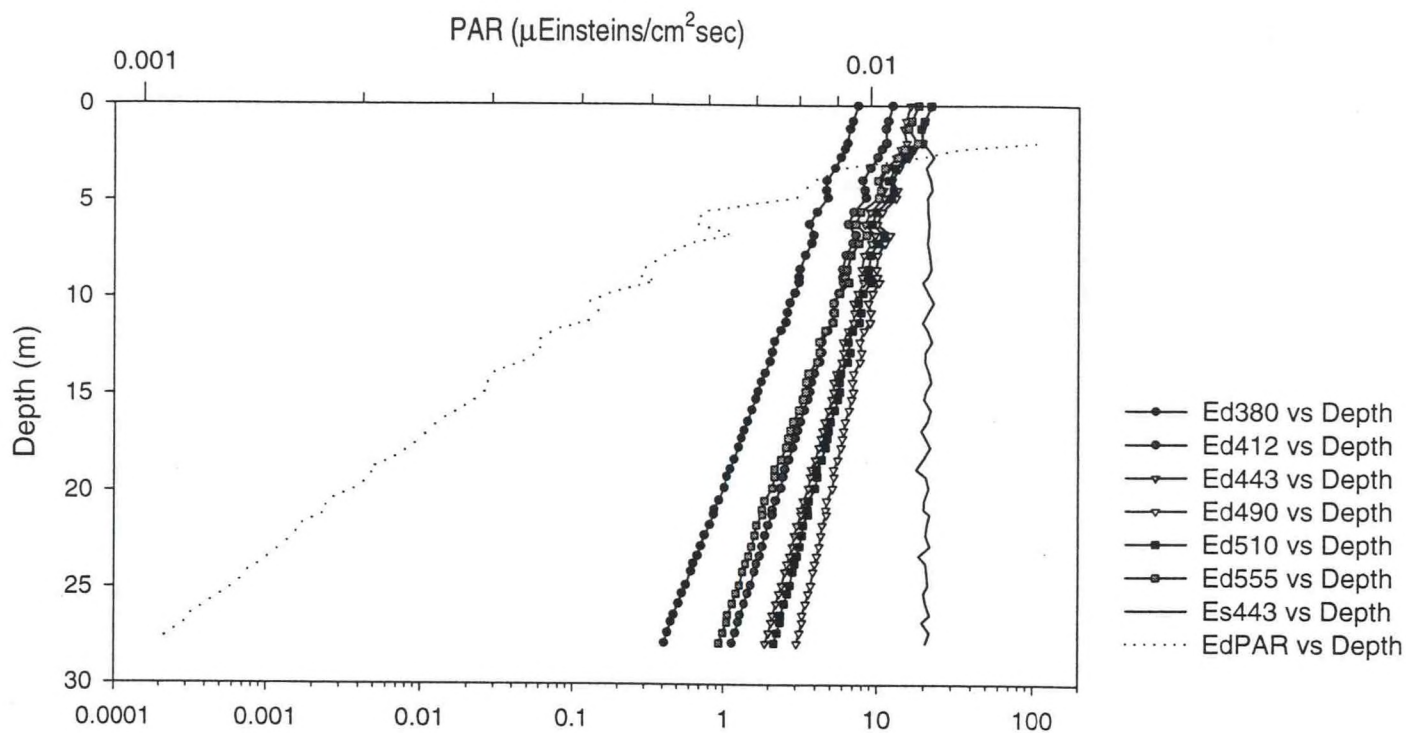
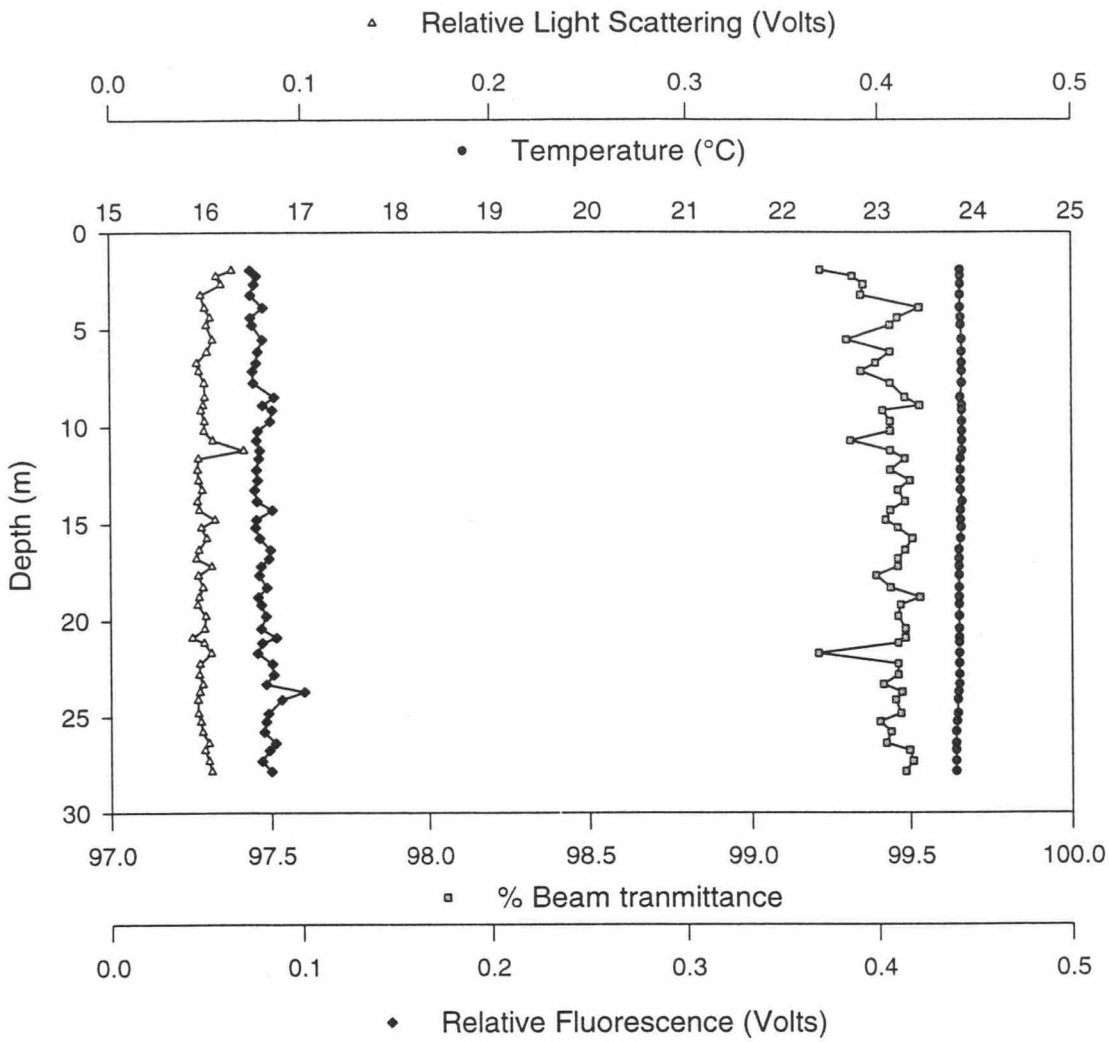

Figure A.5.b - Station 9 Downcast



Diffuse Attenuation Coefficient (k_λ)

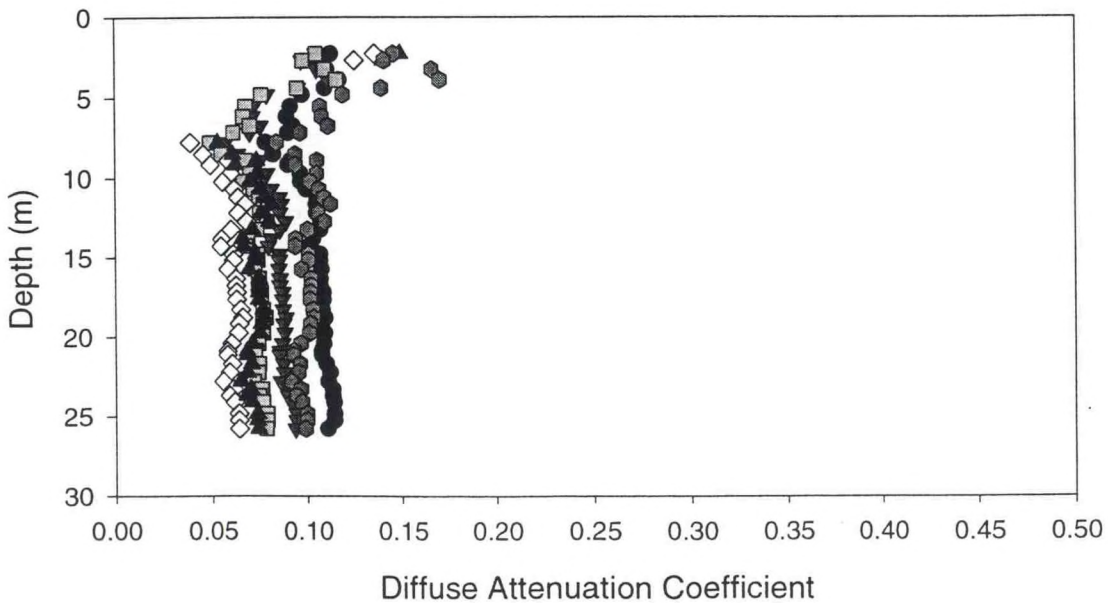

Figure A.6.a - Station 9 Upcast

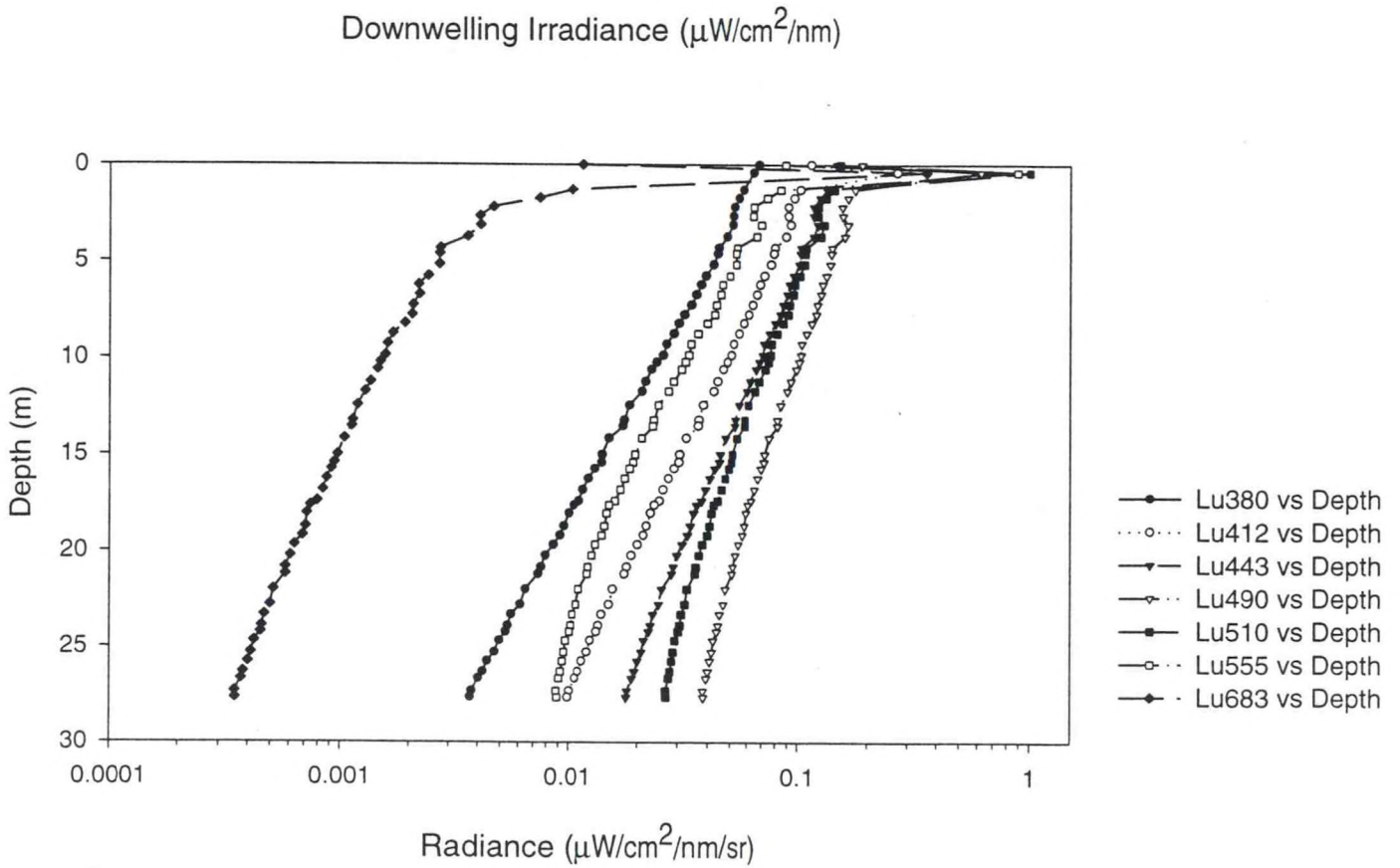
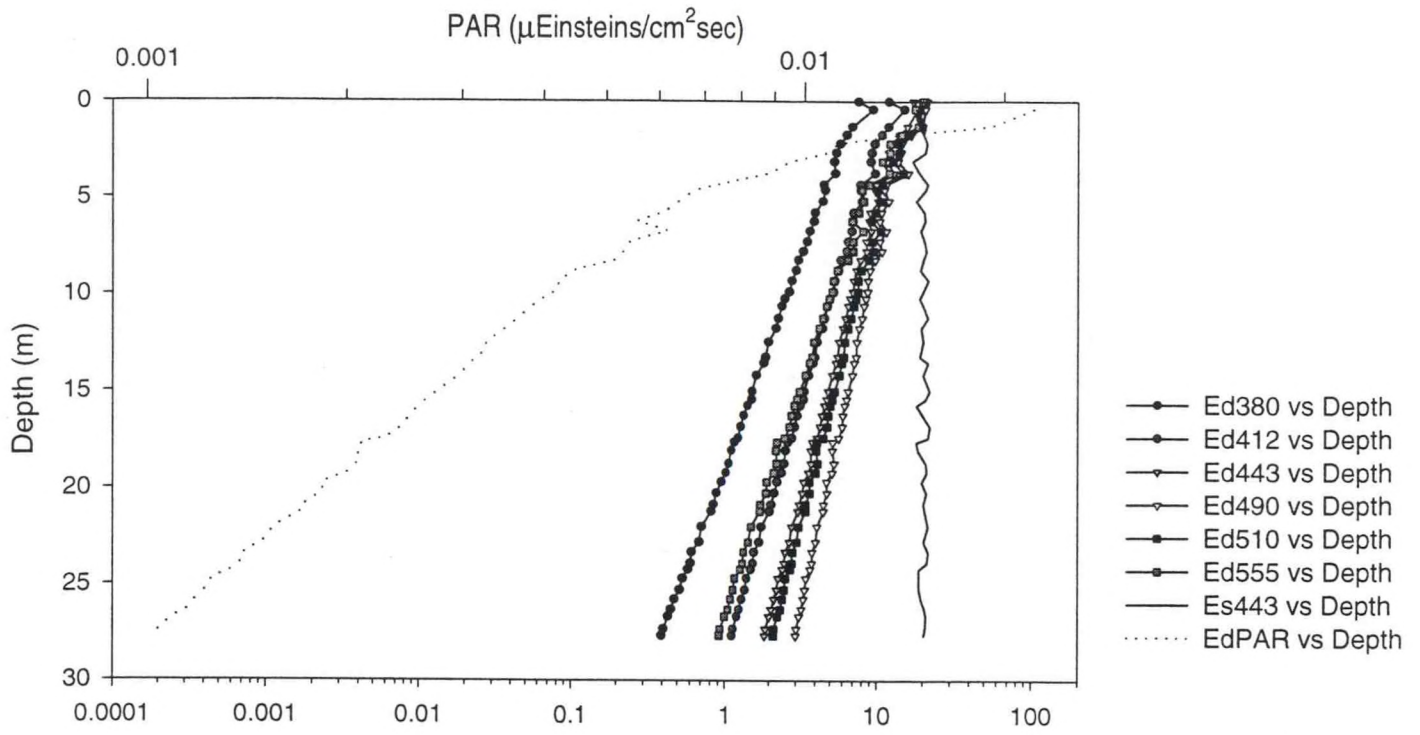
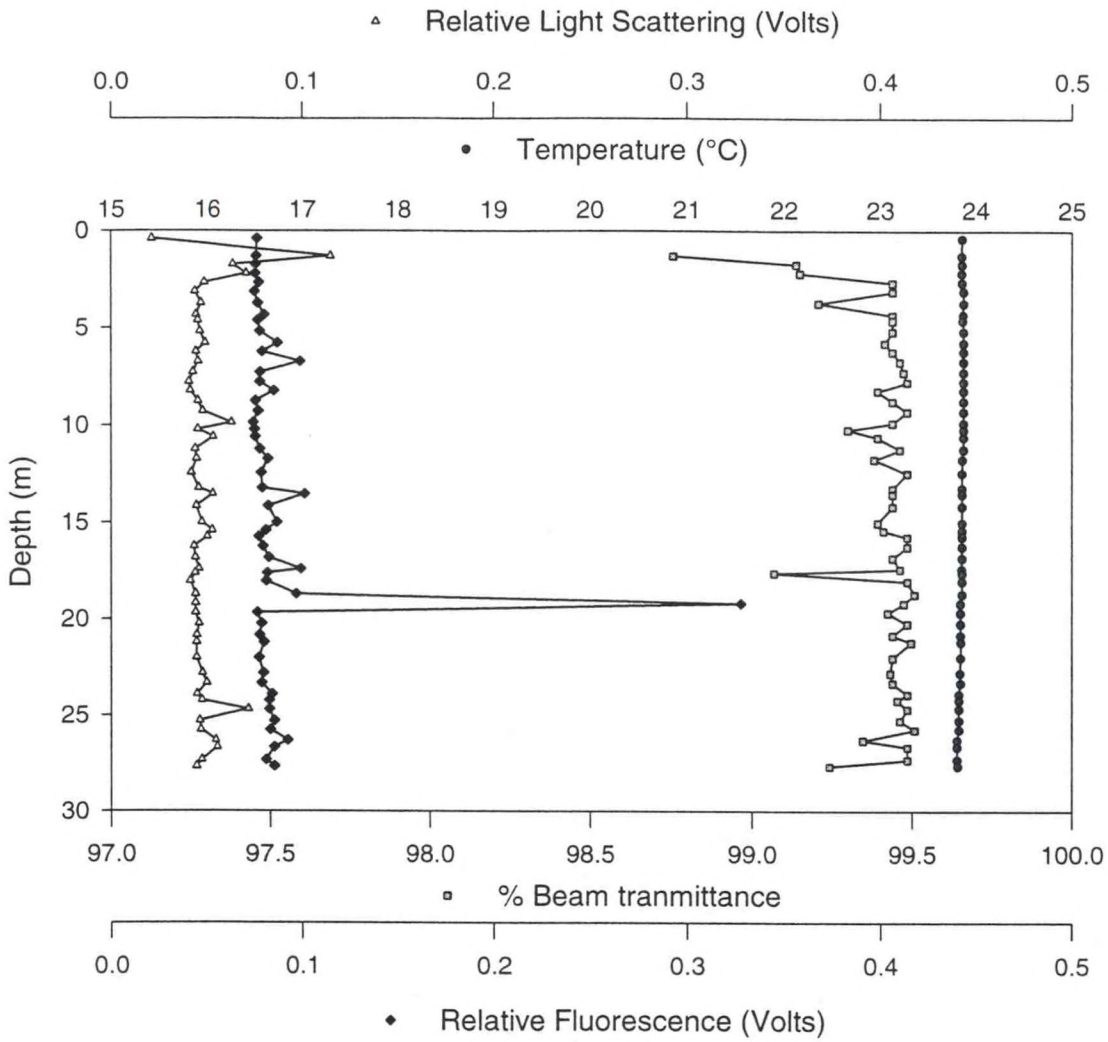

Figure A.6.b - Station 9 Upcast



Diffuse Attenuation Coefficient (k_{λ})

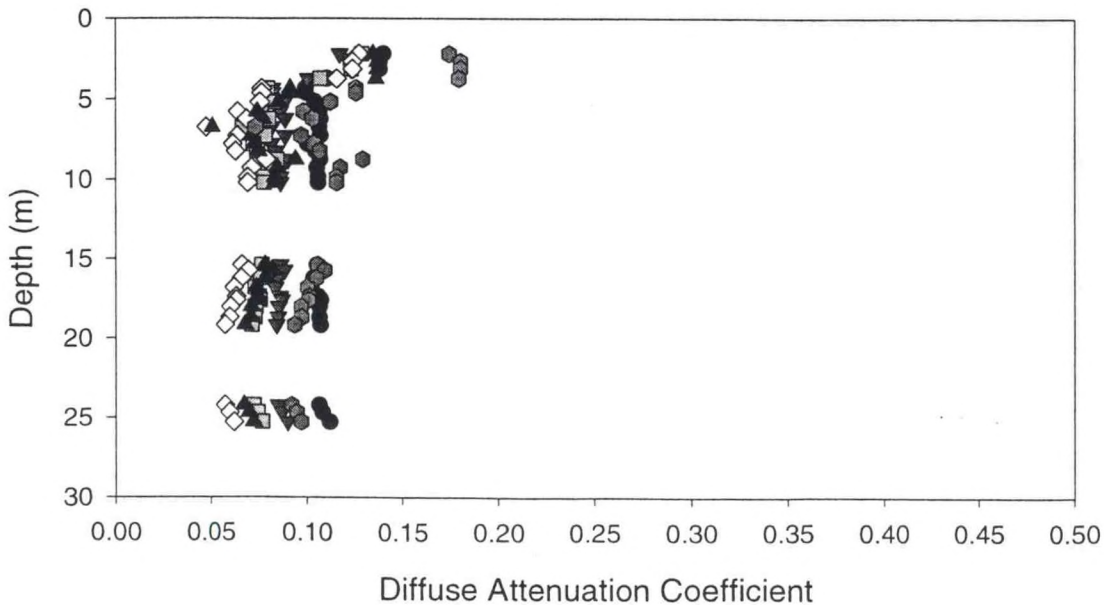

Figure A.7.a - Station 13 Downcast

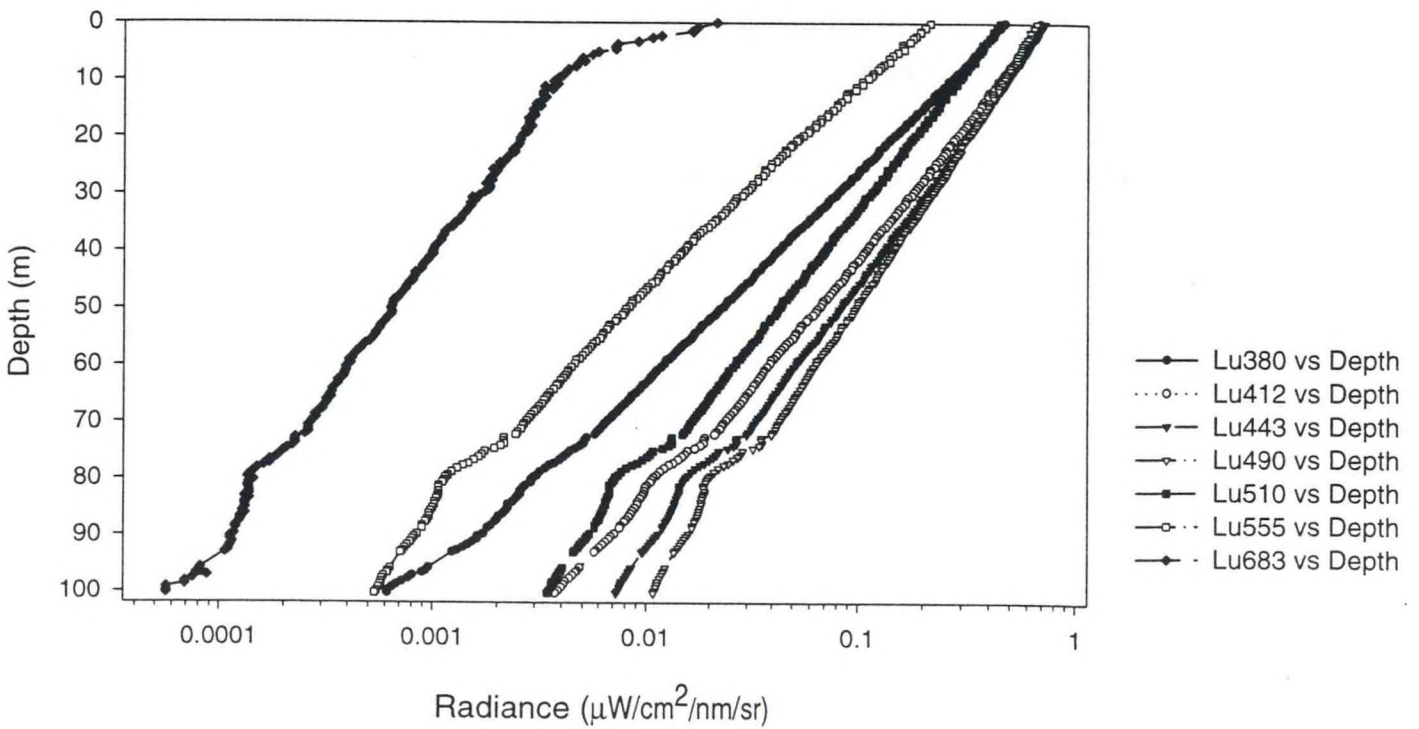
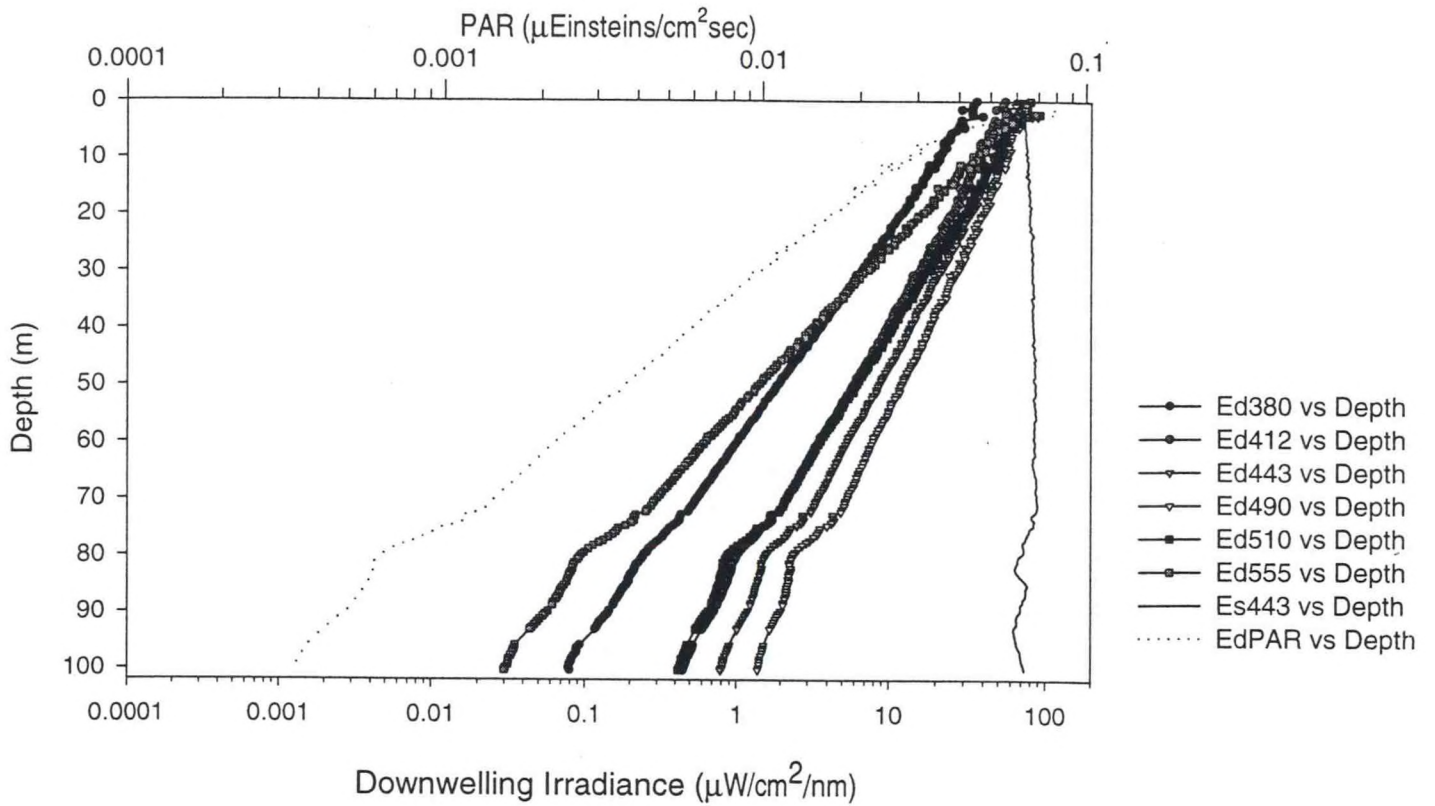
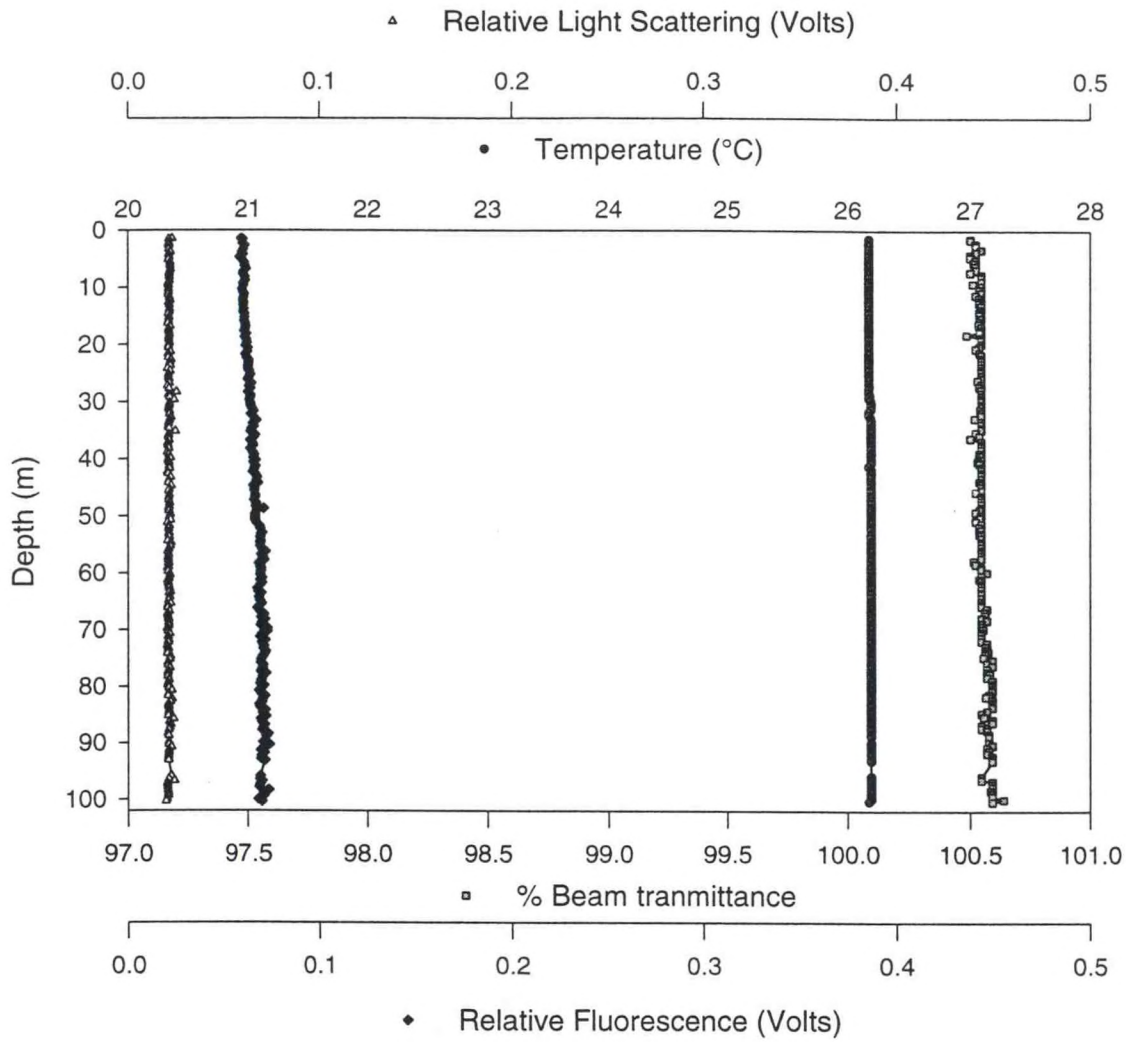

Figure A.7.b - Station 13 Downcast



Diffuse Attenuation Coefficient (k_λ)

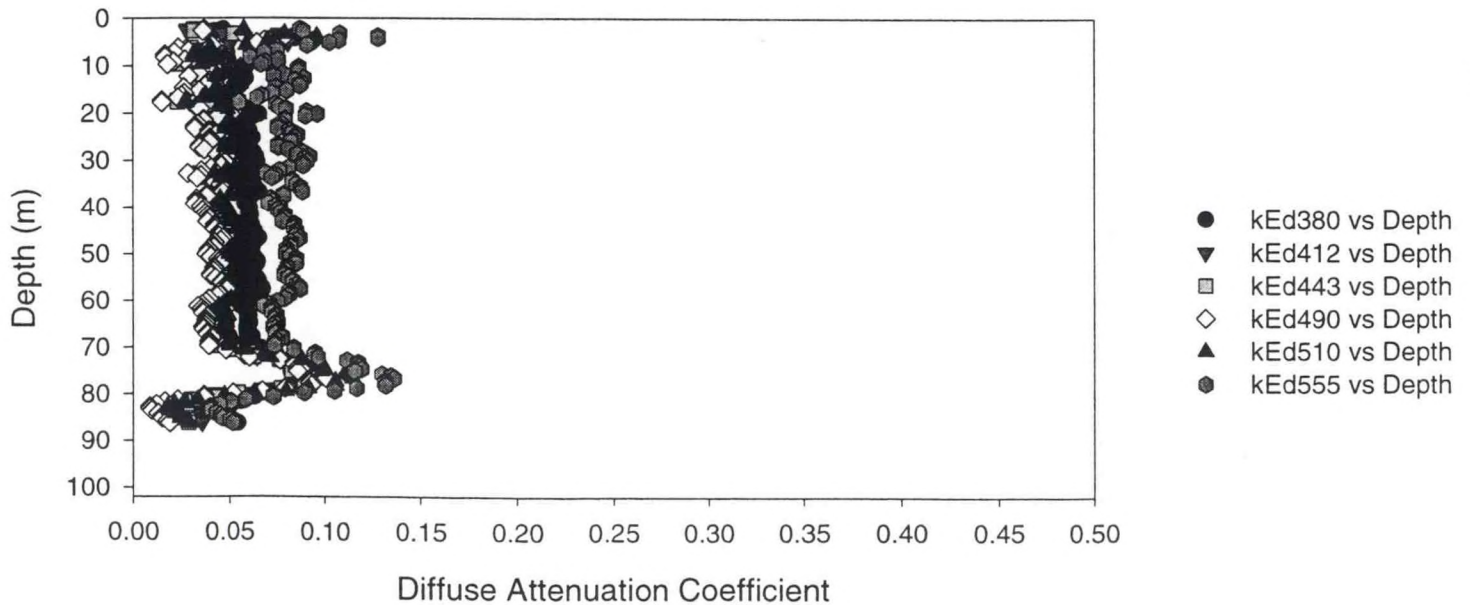

Figure A.8.a - Station 13 Upcast

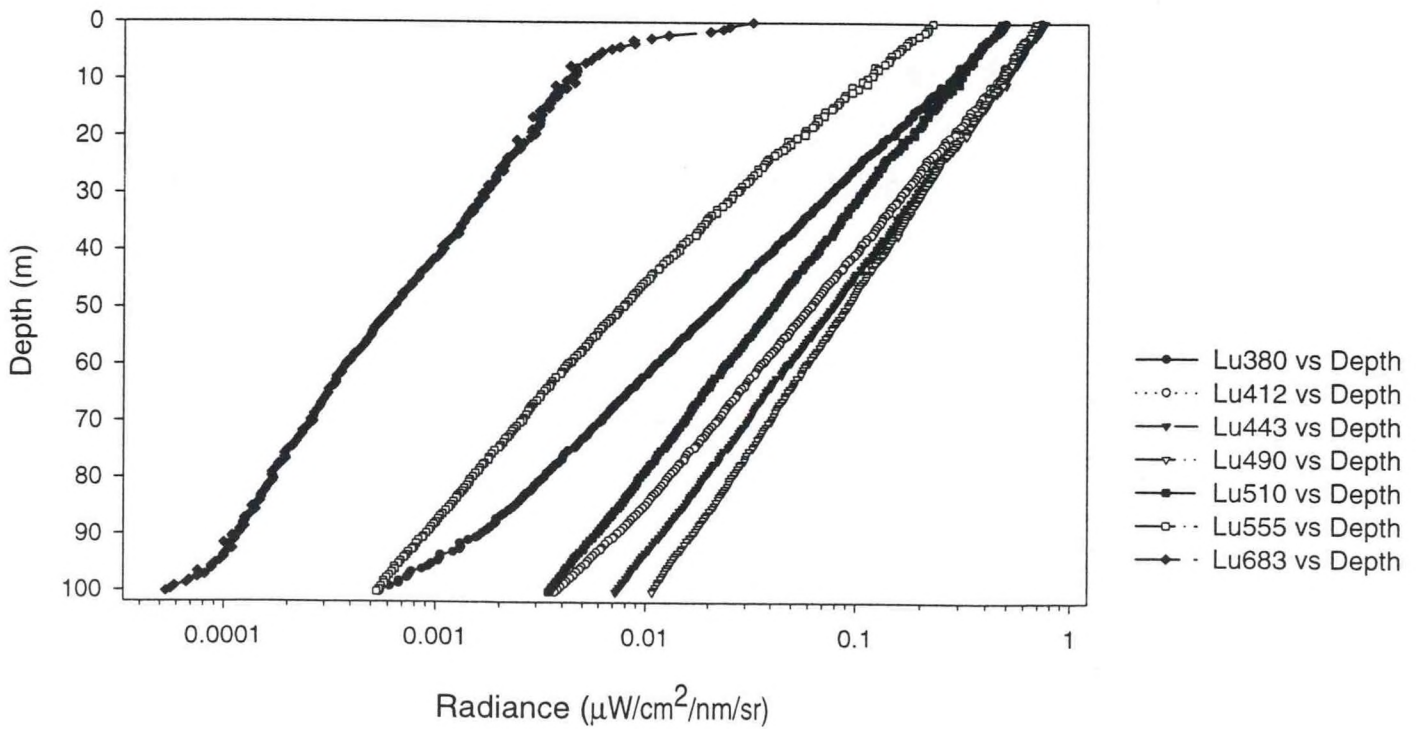
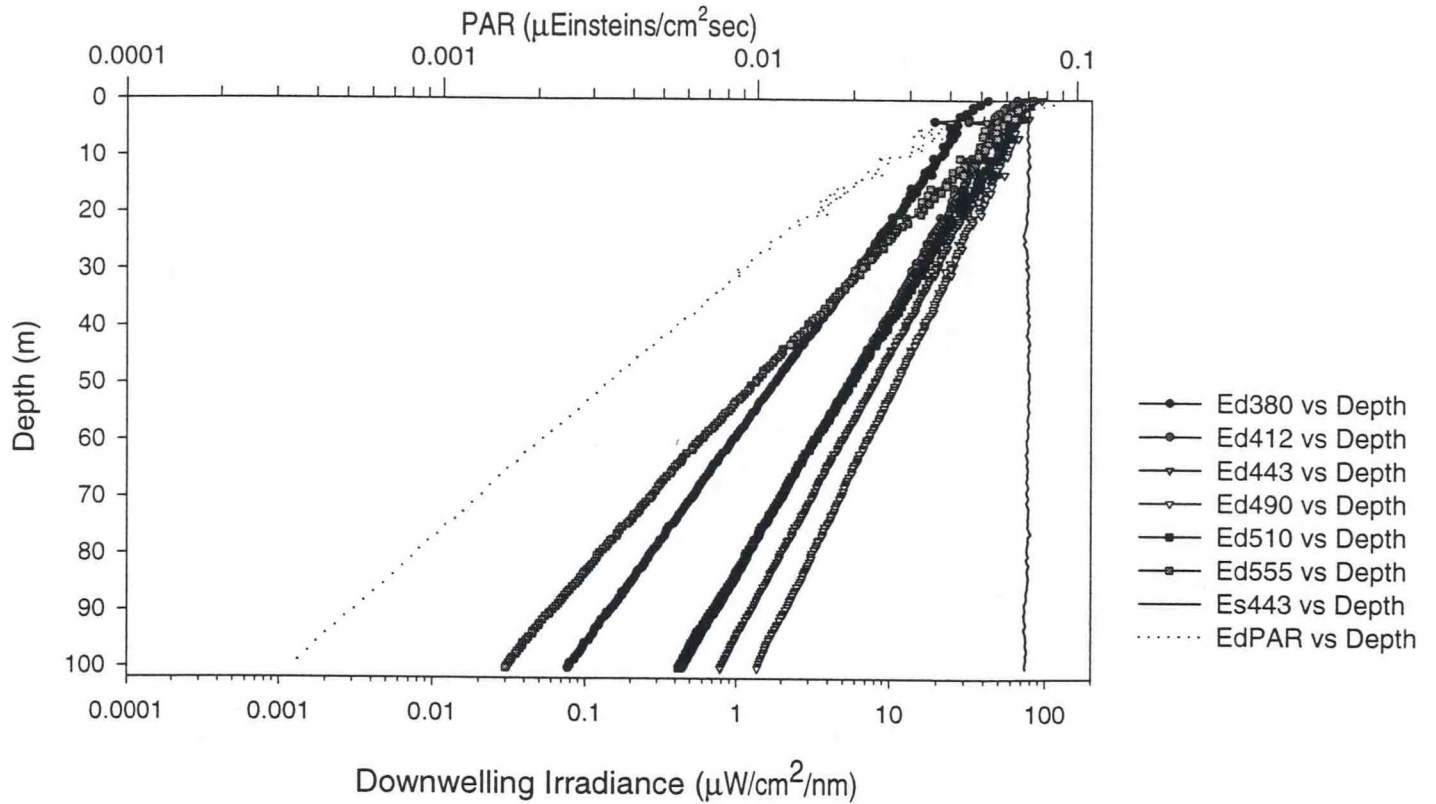
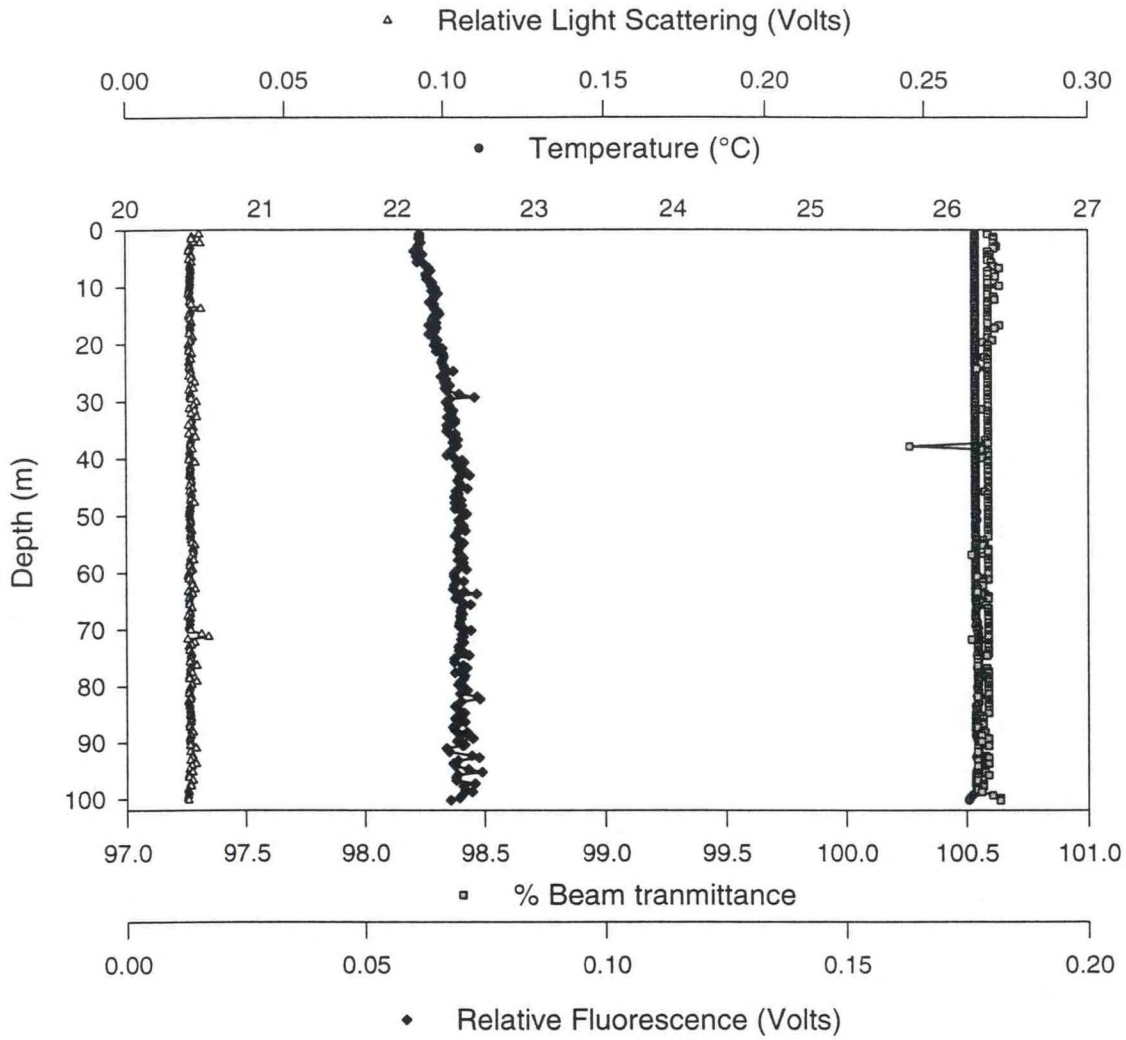

Figure A.8.b - Station 13 Upcast



Diffuse Attenuation Coefficient ($k\lambda$)

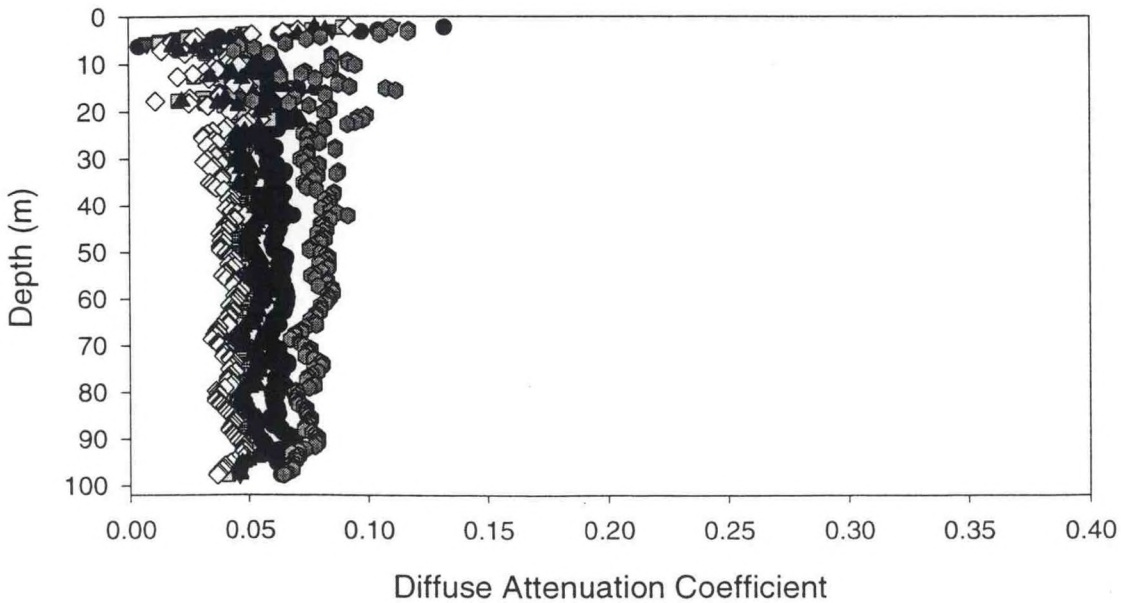

Figure A.9.a - Station 14 Downcast

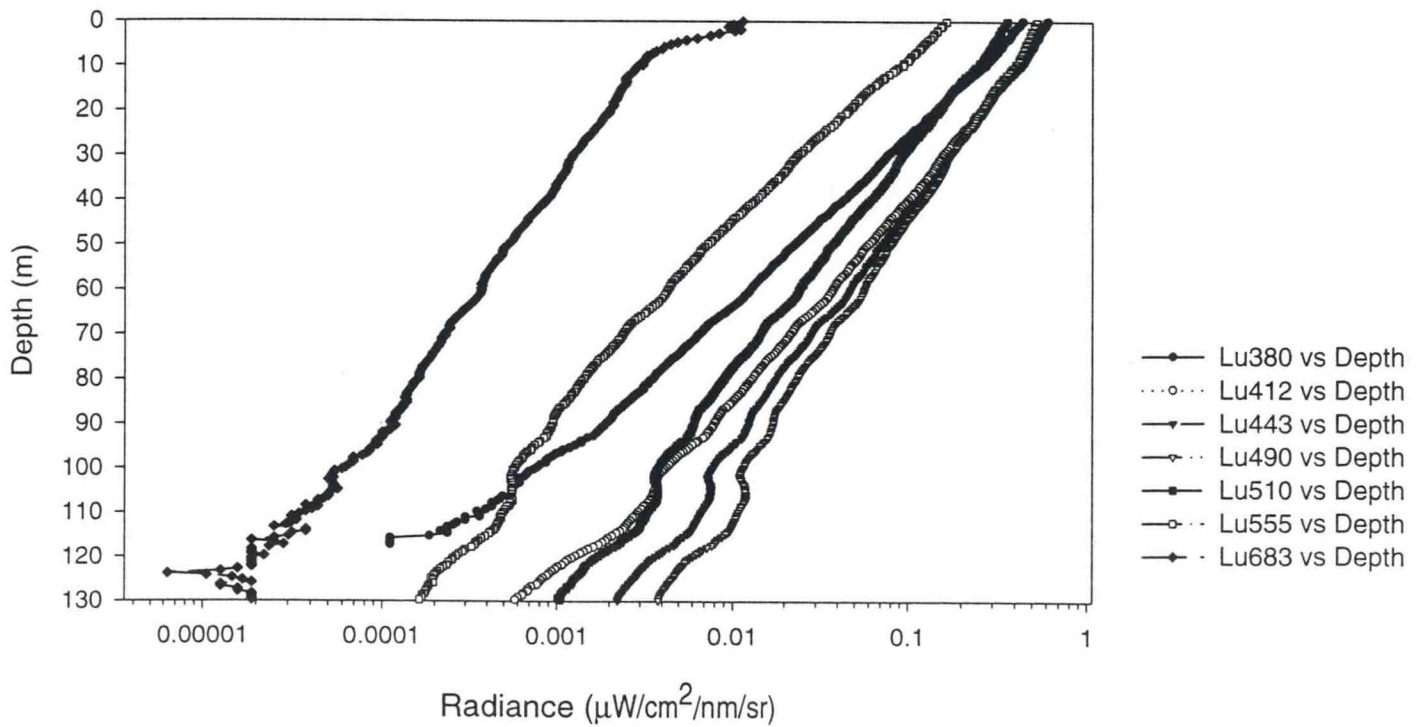
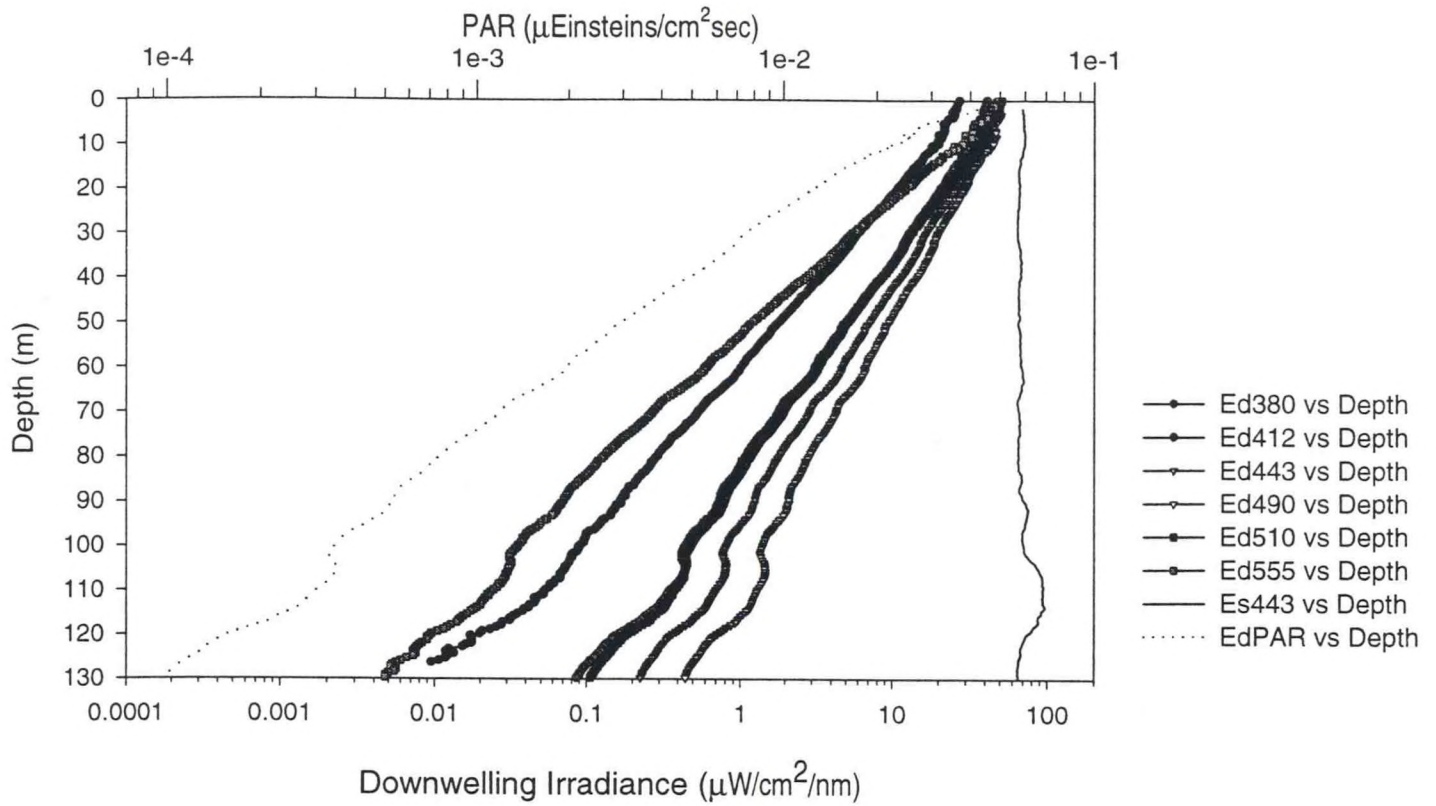
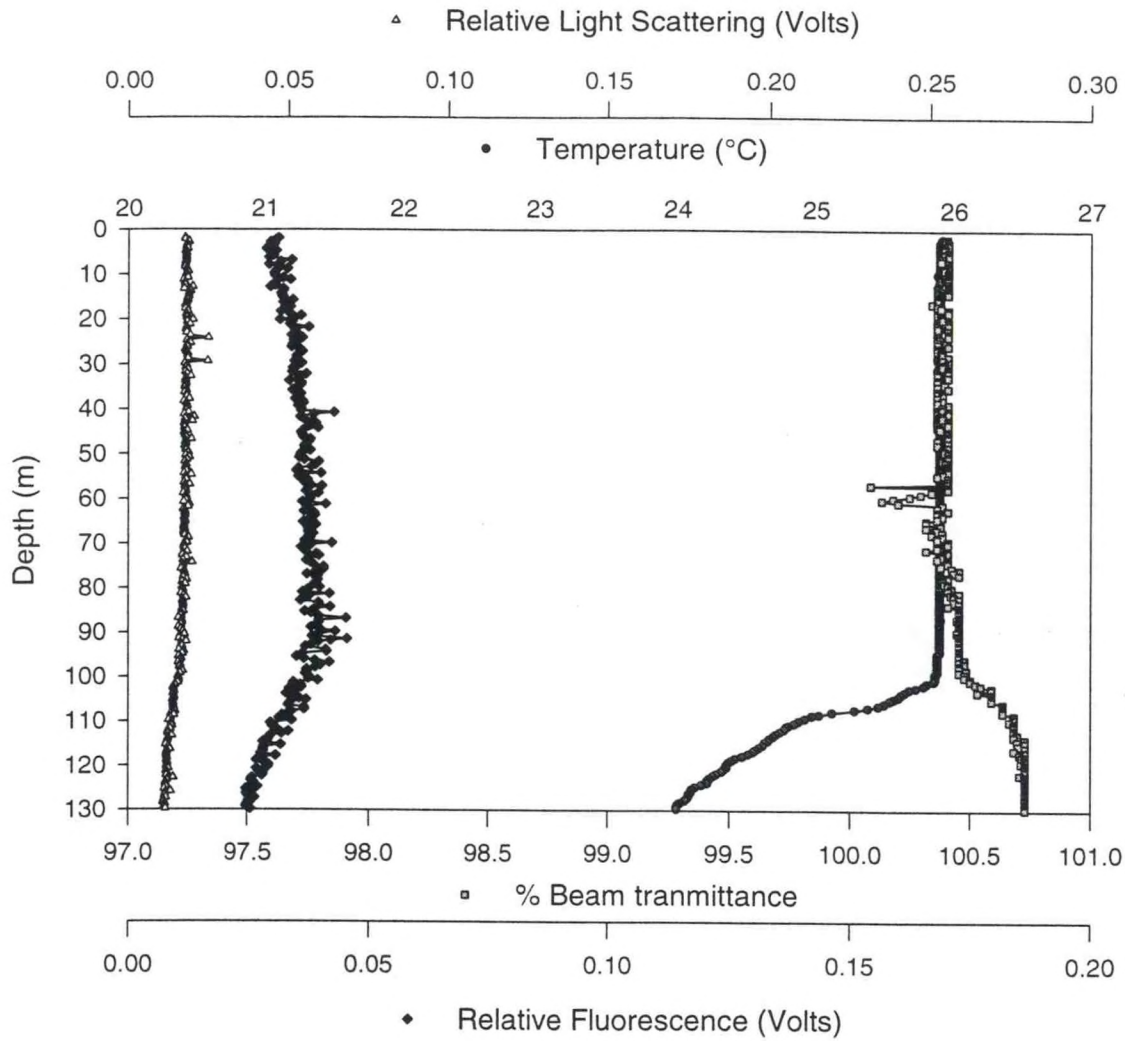

Figure A.9.b - Station 14 Downcast



Diffuse Attenuation Coefficient (k_{λ})

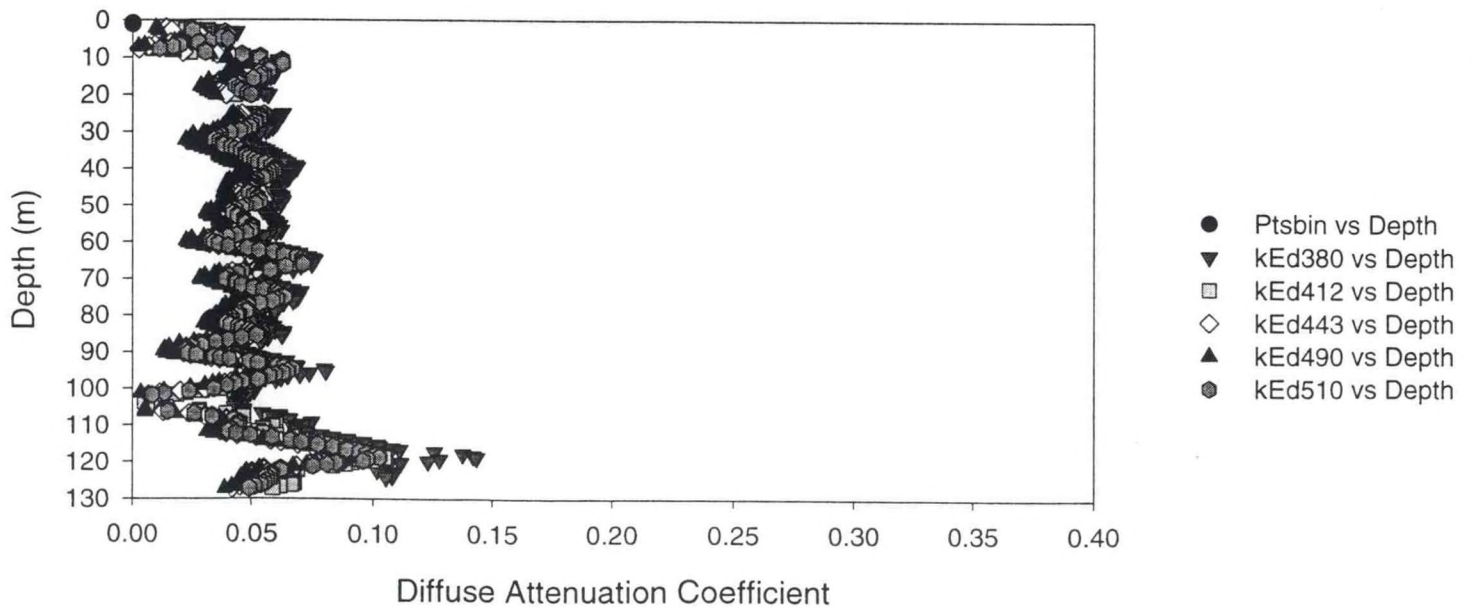

Figure A.10.a - Station 14 Upcast

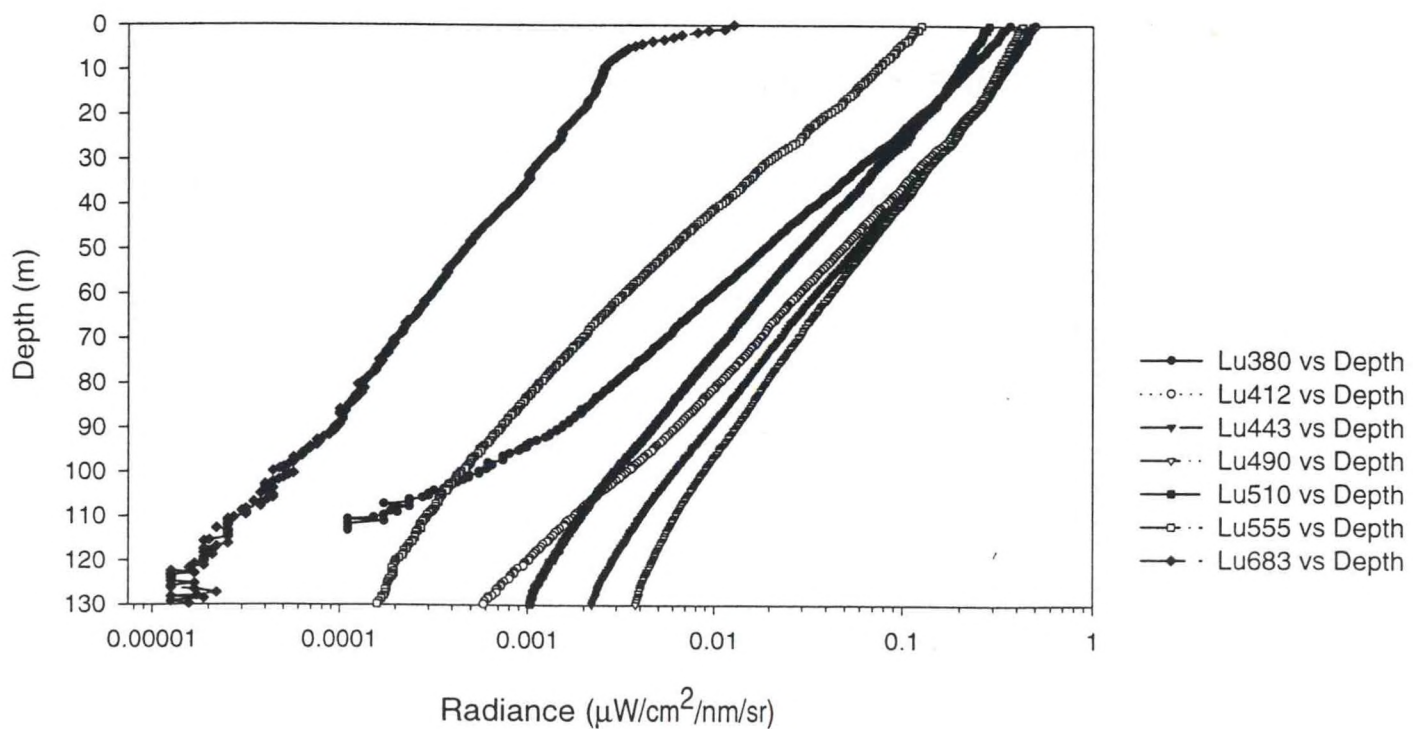
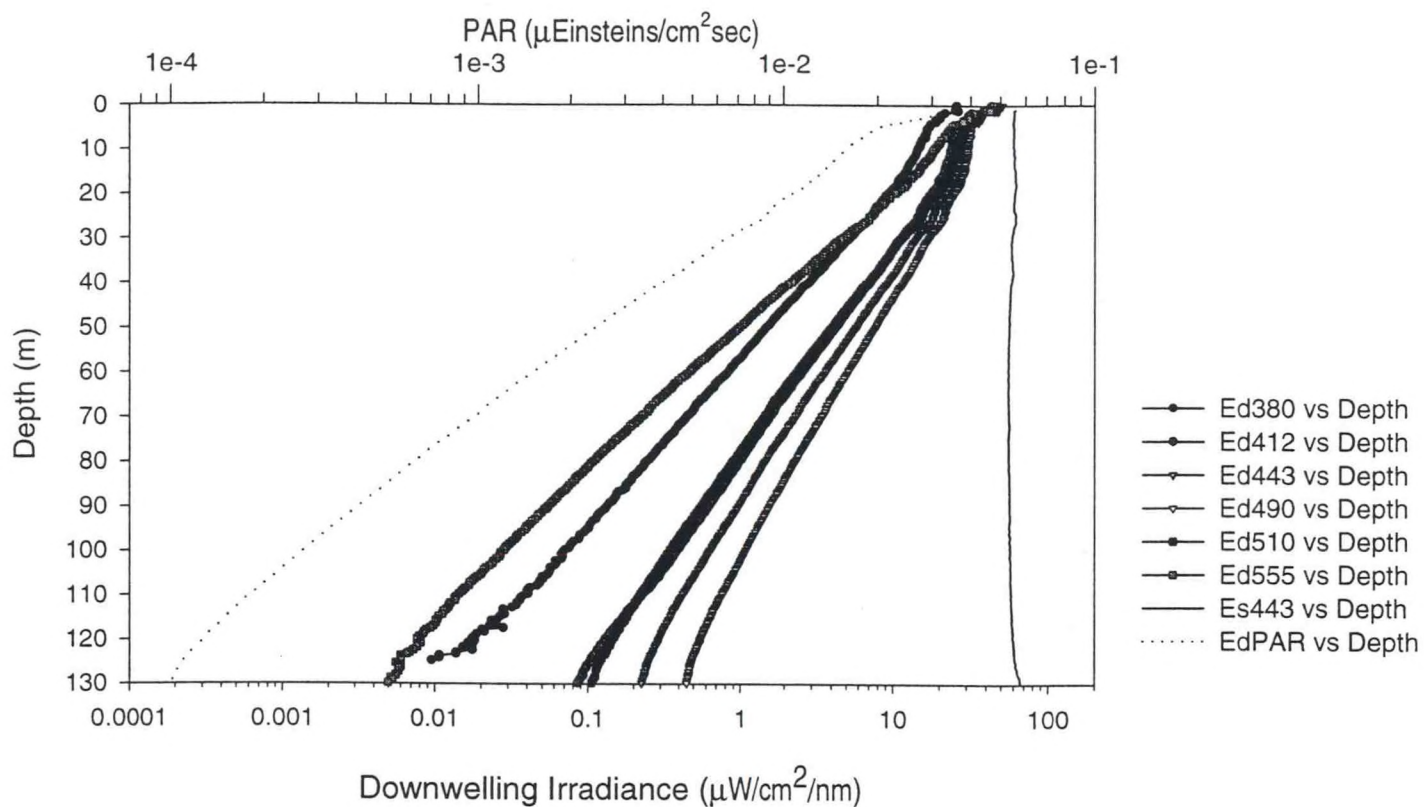
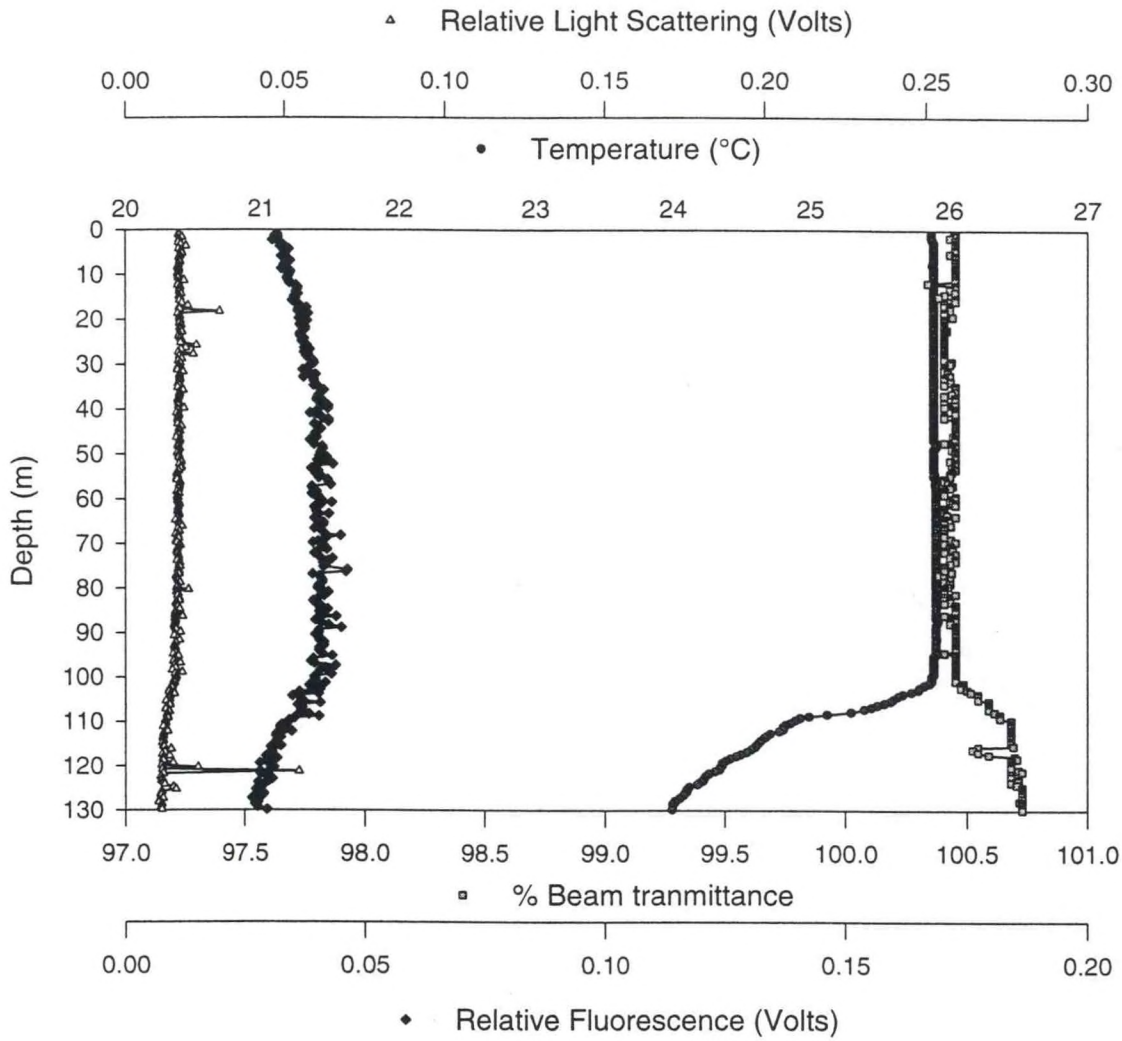

Figure A.10.b - Station 14 Upcast



Diffuse Attenuation Coefficient (k_{λ})

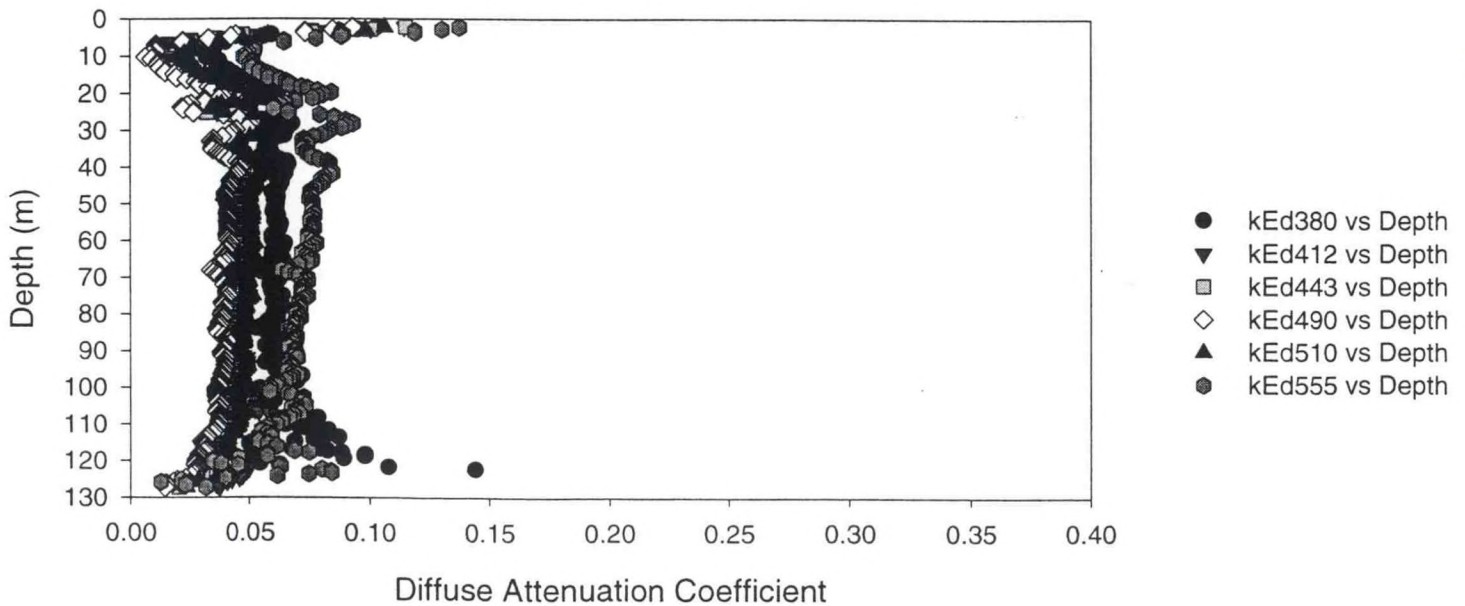

Figure A.11.a - Station 16 Downcast

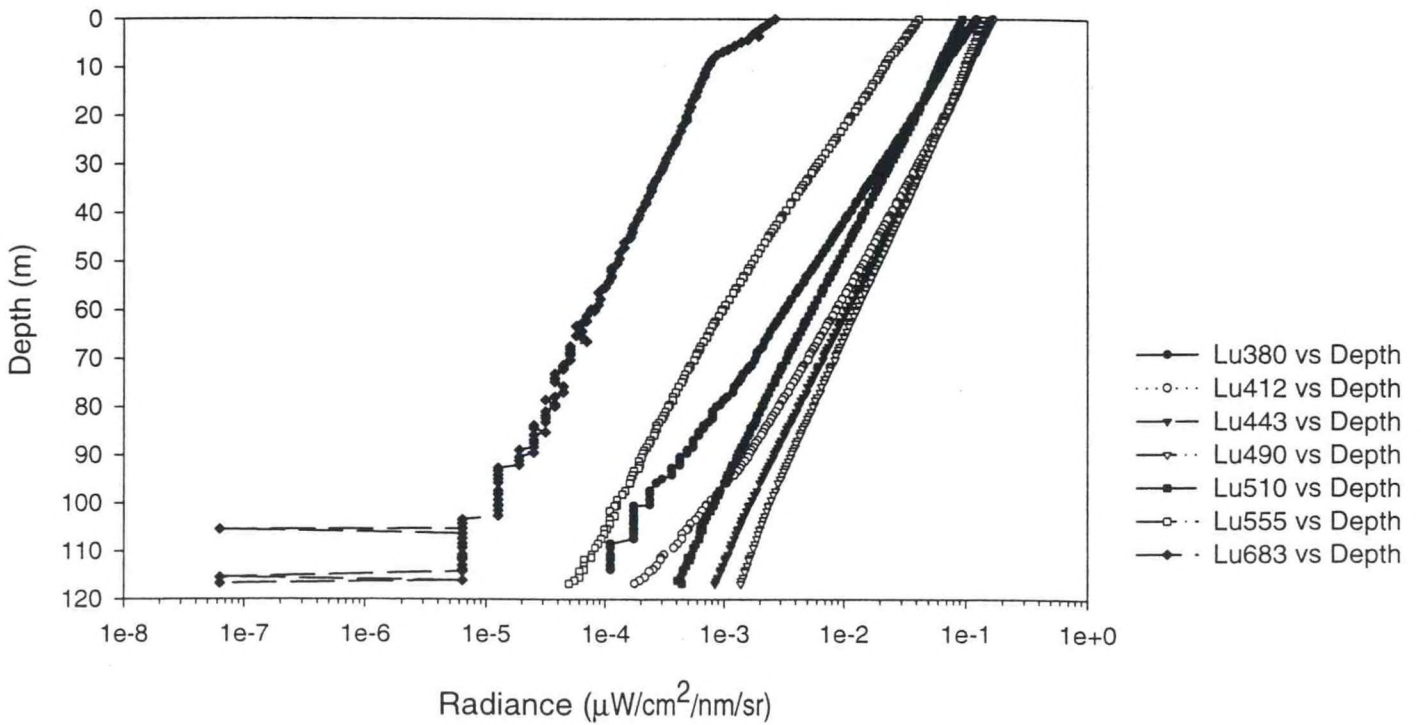
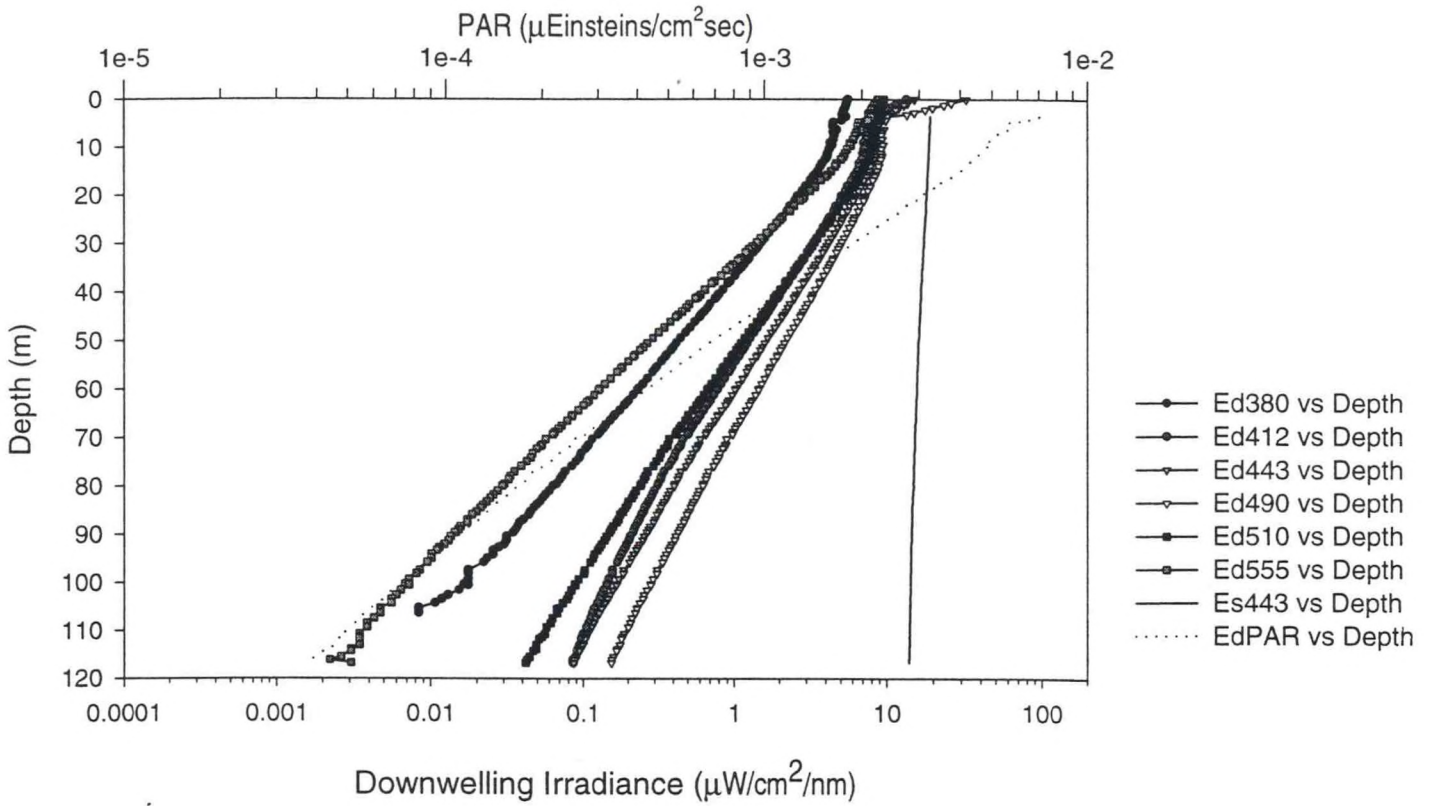

Figure A.11.b - Station 16 Downcast

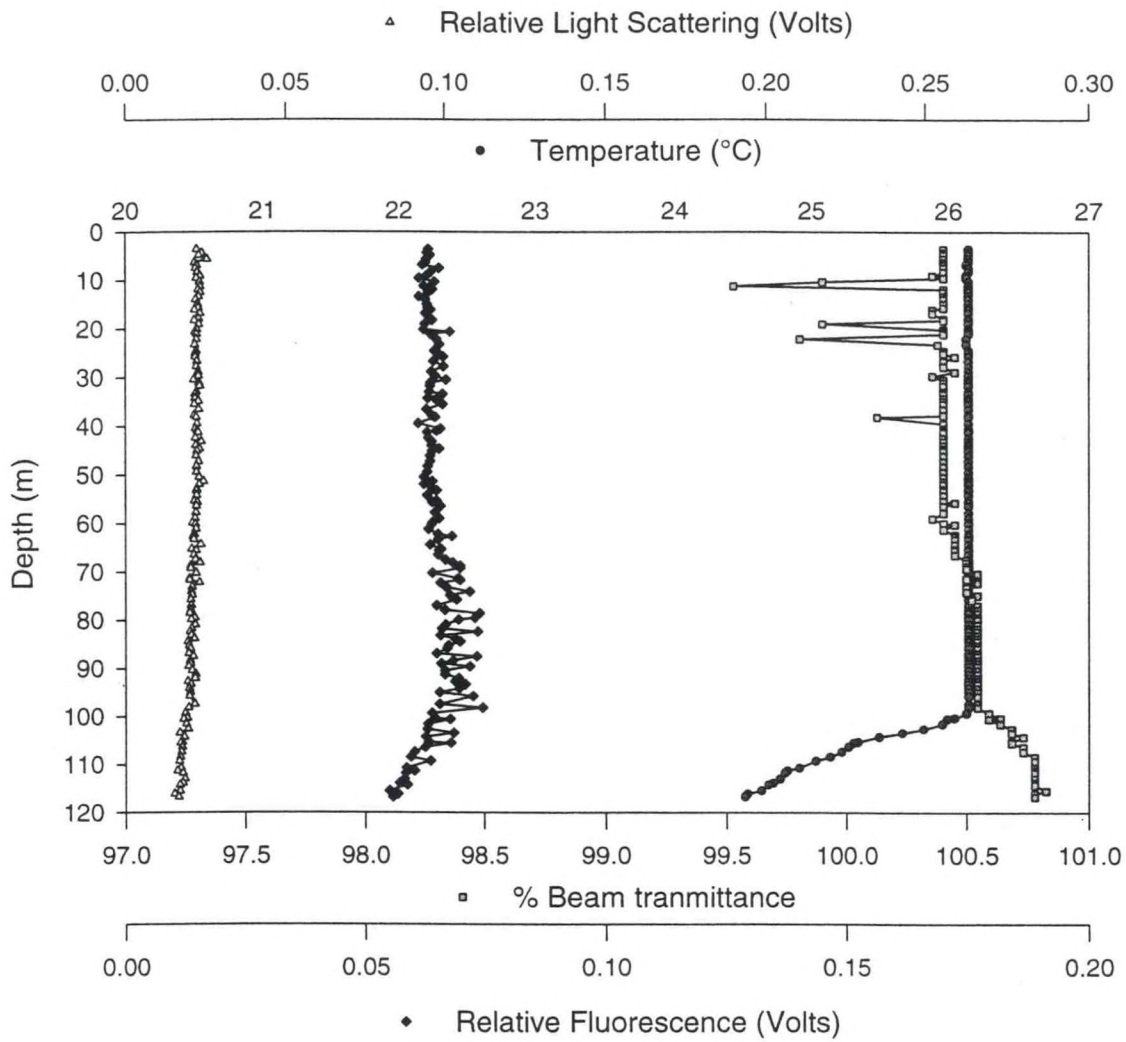

Figure A.12.a - Station 16 Upcast

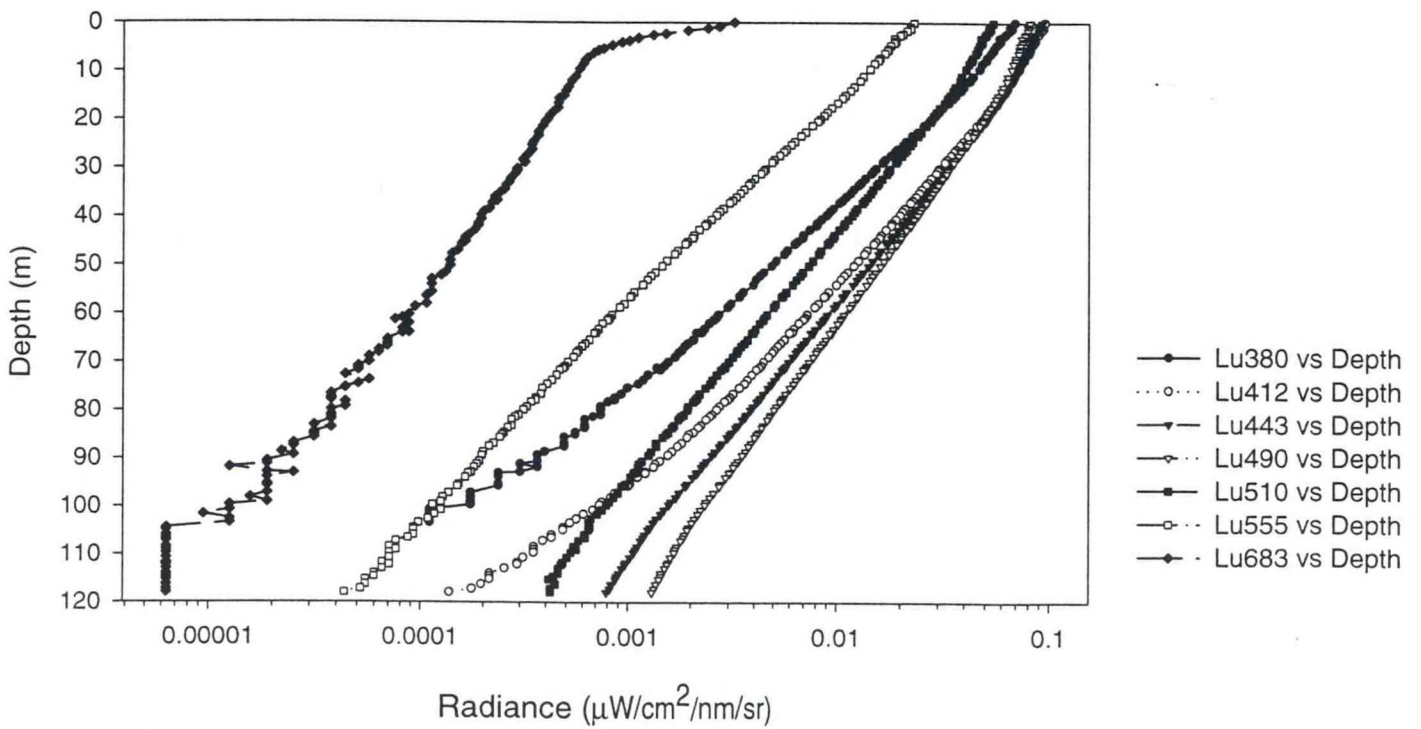
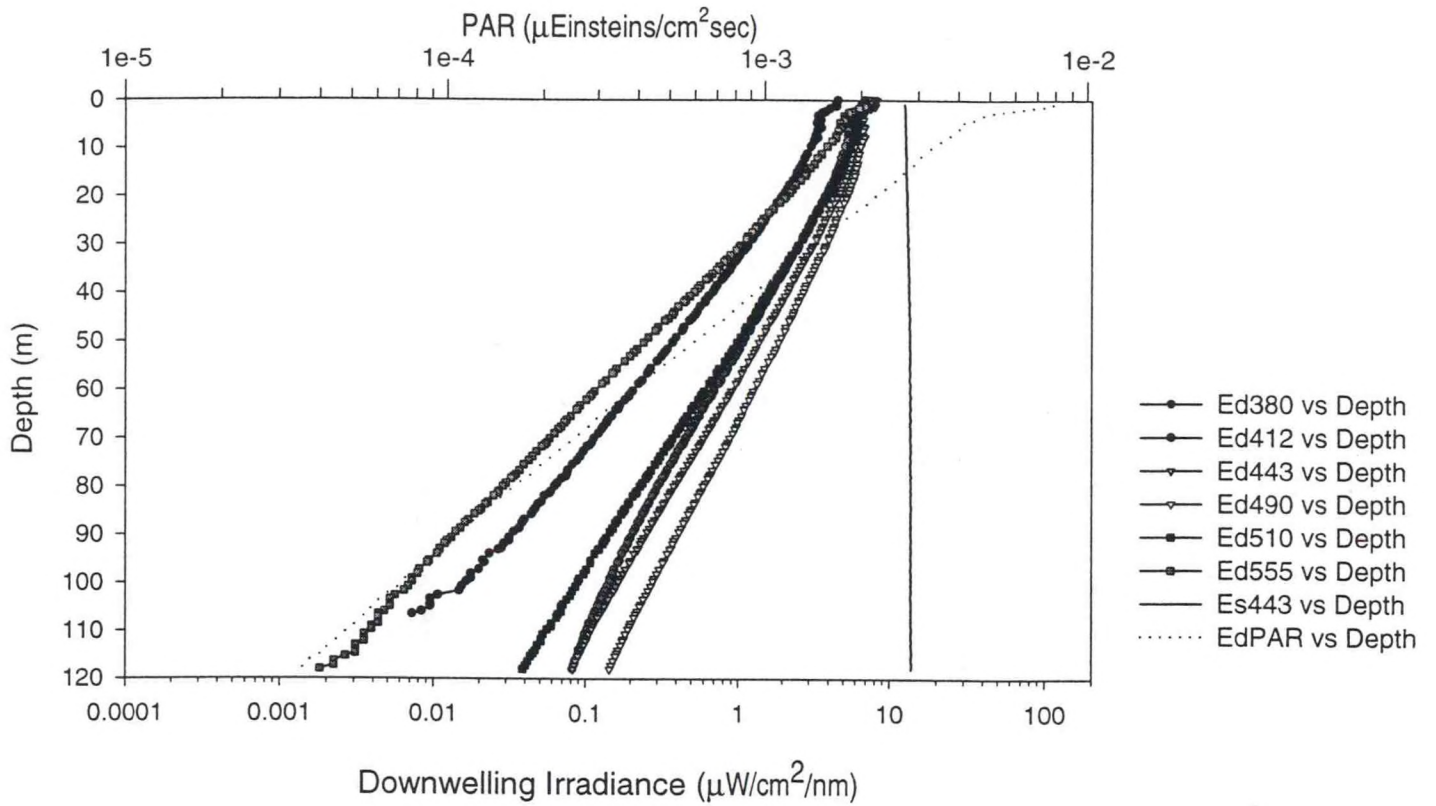
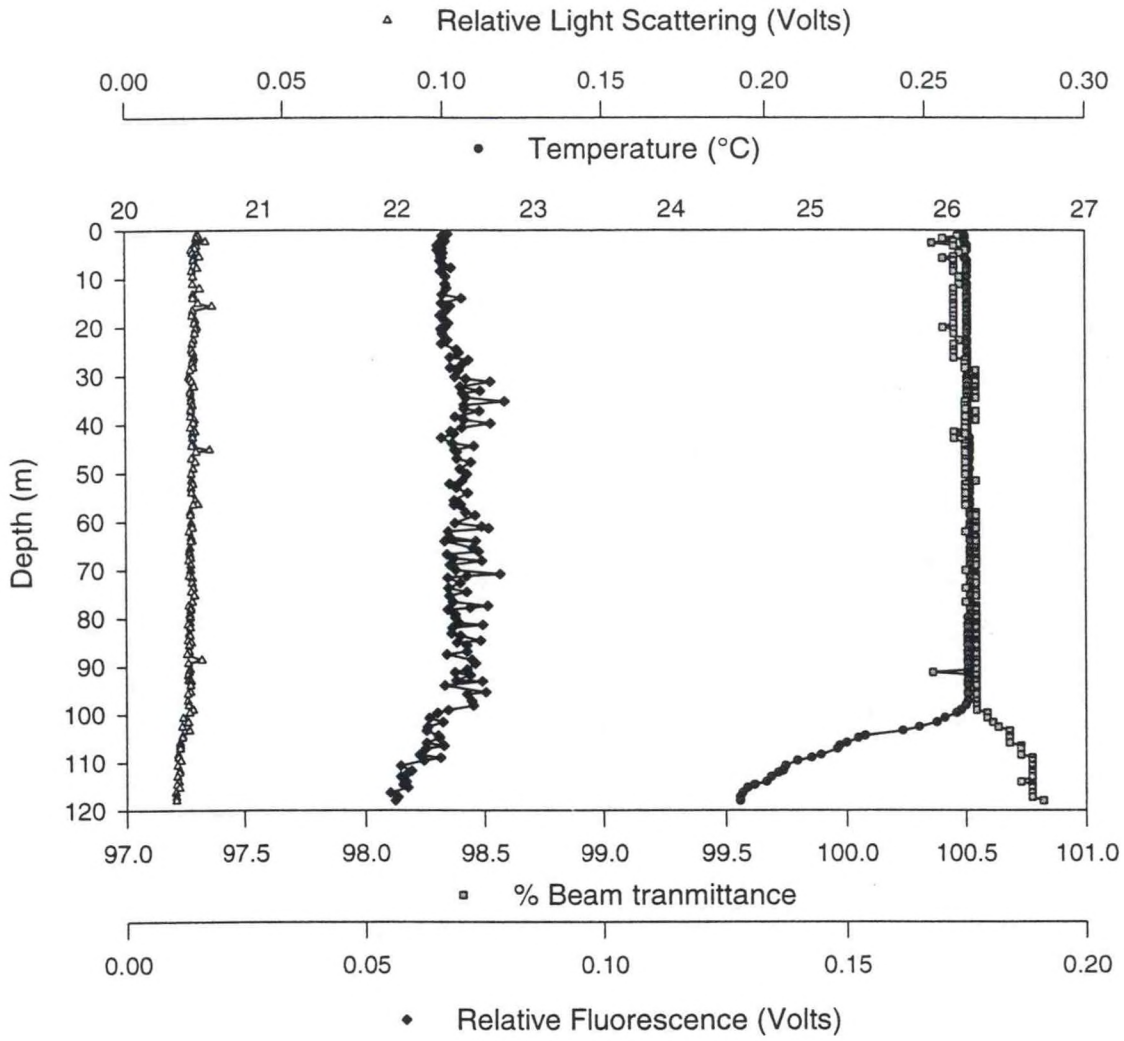

Figure A.12.b - Station 16 Upcast



IX. Appendix B – Sub-surface Light Field Estimation Statistics

The following pages contain tables containing the statistics for calculation of the sub-surface light field. The channel column refers to the optical wavelength; min and max depths are the minimum and maximum depths used in the calculation; n points are the number of points used in the calculation; b0 is the intercept of the regression – the estimated sub-surface light (irradiance and radiance); b1 is the slope of the regression – the estimated attenuation coefficient, min, max, and mean refer to the minimum, maximum, and mean irradiance or radiance values used in the calculation; and std dev, var, uncertainty, and abdev refer to the estimates of the intercept.

channel	min depth	max depth	n points	b0	b1	min	max	mean	std dev	var	uncertainty	abdev
7 Downcast												
ed380	0.5	10	9	47.08	0.75	11.58	41.66	19.38	1.56	1.22	1.31	0.07
ed412	0.5	10	9	76.8	0.79	25.19	71.66	36.93	1.45	1.15	1.3	0.08
ed443	0.5	10	9	102.69	0.79	35.28	87.62	49.27	1.38	1.11	1.26	0.08
ed490	0.5	10	9	125.61	0.8	45.38	97.65	60.29	1.32	1.08	1.28	0.08
ed510	0.5	10	9	124.89	0.8	45.14	93.09	60.08	1.32	1.08	1.28	0.08
ed555	0.5	10	9	123.51	0.79	40.44	89.51	55.69	1.35	1.09	1.28	0.08
lu380	0.5	10	18	0.3	0.77	0.02	0.21	0.07	2.12	1.76	1.03	0.02
lu412	0.5	10	18	0.54	0.83	0.08	0.42	0.19	1.68	1.31	1.02	0.01
lu443	0.5	10	18	0.73	0.87	0.18	0.62	0.33	1.49	1.17	1.02	0.02
lu490	0.5	10	18	1.05	0.92	0.48	0.99	0.68	1.26	1.05	1.02	0.01
lu510	0.5	10	18	0.99	0.93	0.48	0.94	0.65	1.24	1.05	1.03	0.02
lu555	0.5	10	18	0.72	0.93	0.35	0.69	0.47	1.25	1.05	1.04	0.02
lu683	0.5	10	9	0.09	0.7	0.02	0.06	0.03	1.56	1.22	1.17	0.05
7 Upcast												
ed380	0.5	10	20	56.42	0.77	3.81	55.24	13.28	2.2	1.86	1.09	0.06
ed412	0.5	10	10	90.64	0.82	32.85	89.41	49.2	1.42	1.13	1.21	0.07
ed443	0.5	10	10	109.48	0.85	48.23	107.49	65.86	1.34	1.09	1.19	0.06
ed490	0.5	10	10	126.92	0.86	62.38	117.16	80.77	1.26	1.05	1.13	0.05
ed510	0.5	10	10	127.27	0.86	63.63	117.43	81.59	1.26	1.05	1.09	0.03
ed555	0.5	10	20	113.07	0.89	32.79	111.22	56.2	1.45	1.15	1.08	0.06
lu380	0.5	10	5	0.41	0.62	0.12	0.32	0.18	1.46	1.16	1.3	0.04
lu412	0.5	10	5	0.7	0.7	0.27	0.6	0.38	1.34	1.09	1.23	0.04
lu443	0.5	10	5	0.91	0.76	0.43	0.84	0.56	1.29	1.07	1.22	0.04
lu490	0.5	10	5	1.34	0.82	0.79	1.28	0.95	1.2	1.03	1.21	0.04
lu510	0.5	10	2	1.6	0.64	0.91	1.26	1.07	1.26	1.05	0	0
lu555	0.5	10	5	0.91	0.83	0.55	0.89	0.66	1.2	1.03	1.2	0.04
lu683	0.5	10	2	0.37	0.22	0.05	0.16	0.09	2.2	1.86	0	0

channel	min depth	max depth	n points	b0	b1	min	max	mean	std dev	var	uncertainty	abdev
8 Downcast												
ed380	0.5	10	20	34.37	0.86	7.6	32.11	15	1.55	1.21	1.06	0.04
ed412	0.5	10	10	57.16	0.87	29.72	52.48	37.8	1.25	1.05	1.11	0.05
ed443	0.5	10	10	66.54	0.9	39.99	63.66	48.25	1.21	1.04	1.12	0.05
ed490	0.5	10	10	71.24	0.92	47.5	73.11	56.3	1.17	1.02	1.13	0.05
ed510	0.5	10	5	75.75	0.89	54.12	71.18	62.4	1.13	1.02	1.3	0.05
ed555	0.5	10	10	66.76	0.9	39	66.42	48.91	1.23	1.04	1.14	0.05
lu380	0.5	10	20	0.22	0.87	0.05	0.2	0.1	1.52	1.19	1.02	0.01
lu412	0.5	10	20	0.39	0.91	0.15	0.37	0.23	1.34	1.09	1.02	0.01
lu443	0.5	10	20	0.52	0.93	0.24	0.5	0.34	1.25	1.05	1.02	0.01
lu490	0.5	10	20	0.69	0.95	0.43	0.68	0.53	1.15	1.02	1.01	0.01
lu510	0.5	10	20	0.56	0.95	0.33	0.55	0.42	1.17	1.03	1.02	0.01
lu555	0.5	10	10	0.33	0.92	0.22	0.31	0.25	1.14	1.02	1.04	0.02
lu683	0.5	10	10	0.04	0.73	0.01	0.03	0.02	1.56	1.22	1.23	0.08
8 Upcast												
ed380	0.5	10	10	33.07	0.85	14.77	31.3	20.52	1.32	1.08	1.14	0.06
ed412	0.5	10	10	56.96	0.87	27.97	51.8	36.8	1.26	1.05	1.15	0.06
ed443	0.5	10	10	70.79	0.88	36.67	64.97	47.42	1.24	1.05	1.18	0.07
ed490	0.5	10	10	80.51	0.88	43.2	74.14	55.63	1.22	1.04	1.2	0.08
ed510	0.5	10	10	81.99	0.87	40.49	74.8	53.16	1.23	1.05	1.22	0.09
ed555	0.5	10	10	79.98	0.85	34.5	71.55	47.21	1.28	1.06	1.23	0.09
lu380	0.5	10	20	0.22	0.86	0.05	0.21	0.1	1.55	1.21	1.02	0.01
lu412	0.5	10	20	0.4	0.9	0.14	0.38	0.22	1.36	1.1	1.02	0.01
lu443	0.5	10	20	0.51	0.93	0.24	0.5	0.33	1.26	1.06	1.02	0.01
lu490	0.5	10	10	0.69	0.95	0.52	0.67	0.59	1.09	1.01	1.02	0.01
lu510	0.5	10	10	0.56	0.94	0.4	0.54	0.47	1.1	1.01	1.03	0.01
lu555	0.5	10	10	0.32	0.92	0.21	0.31	0.25	1.14	1.02	1.04	0.01
lu683	0.5	10	5	0.03	0.74	0.01	0.03	0.02	1.36	1.1	1.34	0.04
9 Downcast												
ed380	0.5	10	17	7.33	0.91	2.7	6.26	4.01	1.3	1.07	1.06	0.03
ed412	0.5	10	17	12.26	0.92	5.19	11.2	7.25	1.26	1.05	1.09	0.04
ed443	0.5	10	17	15.93	0.92	6.95	15.1	9.55	1.26	1.05	1.11	0.05
ed490	0.5	10	7	21.74	0.89	12.18	19.13	14.58	1.18	1.03	1.32	0.06
ed510	0.5	10	7	21.74	0.88	11.62	19.09	13.98	1.2	1.03	1.35	0.06
ed555	0.5	10	17	18	0.88	5.15	17.84	8.52	1.42	1.13	1.14	0.07
lu380	0.5	10	17	0.08	0.9	0.03	0.06	0.04	1.32	1.08	1.02	0.01
lu412	0.5	10	17	0.13	0.92	0.05	0.11	0.07	1.26	1.06	1.03	0.02
lu443	0.5	10	17	0.16	0.93	0.07	0.14	0.1	1.23	1.04	1.03	0.02
lu490	0.5	10	17	0.2	0.94	0.1	0.18	0.14	1.19	1.03	1.03	0.02
lu510	0.5	10	17	0.16	0.93	0.08	0.14	0.1	1.22	1.04	1.04	0.02
lu555	0.5	10	17	0.09	0.91	0.03	0.08	0.05	1.31	1.08	1.05	0.03
lu683	0.5	10	7	0.01	0.79	0	0.01	0	1.32	1.08	1.37	0.07

channel	min depth	max depth	n points	b0	b1	min	max	mean	std dev	var	uncertainty	abdev
9 Upcast												
ed380	0.5	10	19	7.48	0.9	2.51	6.85	4.07	1.35	1.09	1.03	0.02
ed412	0.5	10	19	11.79	0.92	4.93	11.76	7.31	1.29	1.07	1.05	0.03
ed443	0.5	10	9	17.11	0.88	9.68	15.63	11.8	1.18	1.03	1.2	0.06
ed490	0.5	10	9	20.93	0.87	11.1	19.52	14.05	1.2	1.04	1.27	0.07
ed510	0.5	10	9	20.59	0.86	10.01	19.48	13.22	1.24	1.05	1.26	0.07
ed555	0.5	10	9	19.75	0.83	7.95	18.43	11.2	1.32	1.08	1.25	0.07
lu380	0.5	10	19	0.07	0.91	0.02	0.06	0.04	1.32	1.08	1.03	0.02
lu412	0.5	10	19	0.11	0.92	0.05	0.1	0.07	1.26	1.06	1.03	0.02
lu443	0.5	10	19	0.15	0.93	0.07	0.13	0.1	1.23	1.04	1.03	0.02
lu490	0.5	10	19	0.19	0.94	0.1	0.18	0.13	1.19	1.03	1.03	0.02
lu510	0.5	10	19	0.15	0.93	0.07	0.14	0.1	1.22	1.04	1.04	0.02
lu555	0.5	10	19	0.09	0.91	0.03	0.08	0.05	1.33	1.09	1.06	0.04
lu683	0.5	10	9	0.01	0.73	0	0.01	0	1.6	1.24	1.46	0.13
13 Downcast												
ed380	0.5	10	19	35.39	0.94	20.15	38.84	25.79	1.2	1.03	1.09	0.05
ed412	0.5	10	19	53.99	0.96	36.2	66.65	44.3	1.17	1.02	1.1	0.05
ed443	0.5	10	19	64.71	0.97	44.93	80.43	54.76	1.16	1.02	1.11	0.06
ed490	0.5	10	19	74	0.97	51.57	87.4	62.31	1.16	1.02	1.11	0.06
ed510	0.5	10	19	78.58	0.95	45.52	90.39	58.35	1.21	1.04	1.11	0.06
ed555	0.5	10	19	78.43	0.92	33.83	84.24	49.04	1.31	1.08	1.11	0.06
lu380	0.5	10	19	0.46	0.95	0.26	0.42	0.34	1.17	1.02	1.01	0.01
lu412	0.5	10	19	0.67	0.96	0.43	0.63	0.53	1.12	1.01	1.01	0.01
lu443	0.5	10	19	0.71	0.96	0.47	0.66	0.57	1.12	1.01	1.01	0.01
lu490	0.5	10	19	0.65	0.97	0.45	0.61	0.53	1.1	1.01	1.01	0.01
lu510	0.5	10	19	0.44	0.96	0.28	0.41	0.35	1.13	1.02	1.01	0.01
lu555	0.5	10	19	0.21	0.93	0.1	0.19	0.14	1.21	1.04	1.02	0.01
lu683	0.5	10	9	0.02	0.77	0.01	0.02	0.01	1.45	1.15	1.23	0.06
13 Upcast												
ed380	0.5	10	5	42.31	0.86	27.75	37.77	32.58	1.12	1.01	1.08	0.01
ed412	0.5	10	5	65.18	0.89	46.61	61.36	53.01	1.11	1.01	1.07	0.01
ed443	0.5	10	5	74.75	0.92	59.08	74.16	64.88	1.1	1.01	1.12	0.02
ed490	0.5	10	2	93.91	0.82	73.56	80.69	77.04	1.07	1	0	0
ed510	0.5	10	5	81.73	0.91	63.03	78.55	69.51	1.09	1.01	1.13	0.03
ed555	0.5	10	10	82.21	0.88	39.96	74.36	56.97	1.21	1.04	1.14	0.05
lu380	0.5	10	20	0.49	0.94	0.27	0.48	0.36	1.19	1.03	1.02	0.01
lu412	0.5	10	20	0.72	0.95	0.45	0.7	0.56	1.15	1.02	1.02	0.01
lu443	0.5	10	20	0.75	0.96	0.48	0.73	0.59	1.14	1.02	1.02	0.01
lu490	0.5	10	20	0.68	0.96	0.46	0.67	0.55	1.12	1.01	1.02	0.01
lu510	0.5	10	20	0.47	0.95	0.29	0.46	0.36	1.15	1.02	1.02	0.01
lu555	0.5	10	20	0.23	0.93	0.11	0.22	0.15	1.24	1.05	1.02	0.02
lu683	0.5	10	10	0.03	0.71	0.01	0.02	0.01	1.69	1.31	1.23	0.09

channel	min depth	max depth	n points	b0	b1	min	max	mean	std dev	var	uncertainty	abdev
14 Downcast												
ed380	0.5	10	18	26.94	0.97	18.02	25.78	21.87	1.11	1.01	1.04	0.02
ed412	0.5	10	18	40.81	0.98	30.45	39.34	35.55	1.07	1	1.04	0.02
ed443	0.5	10	18	47.29	0.98	36.34	46.44	42.26	1.07	1	1.05	0.02
ed490	0.5	10	18	50.37	0.99	40.06	50.05	46.08	1.06	1	1.05	0.03
ed510	0.5	10	18	50.61	0.97	34.69	47.71	42.28	1.1	1.01	1.06	0.03
ed555	0.5	10	18	48.61	0.95	25.08	43.16	34.34	1.18	1.03	1.05	0.03
lu380	0.5	10	18	0.44	0.95	0.26	0.39	0.33	1.14	1.02	1.01	0.01
lu412	0.5	10	18	0.6	0.97	0.41	0.56	0.49	1.1	1.01	1.01	0.01
lu443	0.5	10	18	0.6	0.97	0.42	0.56	0.5	1.09	1.01	1.01	0.01
lu490	0.5	10	18	0.52	0.97	0.39	0.49	0.45	1.08	1.01	1.01	0.01
lu510	0.5	10	18	0.36	0.96	0.24	0.33	0.29	1.11	1.01	1.01	0.01
lu555	0.5	10	18	0.16	0.94	0.09	0.15	0.12	1.17	1.03	1.01	0.01
lu683	0.5	10	18	0.01	0.86	0	0.01	0	1.55	1.21	1.19	0.11
14 Upcast												
ed380	0.5	10	10	25.63	0.92	16.58	26.25	19.98	1.17	1.02	1.1	0.03
ed412	0.5	10	5	43.32	0.88	30.62	39.19	34.03	1.13	1.02	1.26	0.04
ed443	0.5	10	5	50.49	0.88	35.33	45.22	39.27	1.13	1.02	1.27	0.04
ed490	0.5	10	10	46.64	0.92	31.83	47.45	37.07	1.15	1.02	1.1	0.04
ed510	0.5	10	10	46.12	0.91	29.11	46.25	34.95	1.17	1.03	1.1	0.04
ed555	0.5	10	10	44.33	0.88	23.39	42.32	30.2	1.22	1.04	1.09	0.04
lu380	0.5	10	20	0.37	0.95	0.22	0.34	0.28	1.16	1.02	1.01	0.01
lu412	0.5	10	20	0.49	0.96	0.34	0.47	0.4	1.11	1.01	1.01	0.01
lu443	0.5	10	20	0.48	0.97	0.35	0.47	0.4	1.1	1.01	1.01	0.01
lu490	0.5	10	20	0.43	0.97	0.32	0.41	0.36	1.09	1.01	1.01	0.01
lu510	0.5	10	20	0.28	0.96	0.2	0.28	0.23	1.11	1.01	1.01	0.01
lu555	0.5	10	20	0.13	0.95	0.07	0.12	0.09	1.18	1.03	1.01	0.01
lu683	0.5	10	10	0.01	0.77	0	0.01	0.01	1.5	1.18	1.11	0.04
16 Downcast												
ed380	0.5	10	11	5.52	0.97	4.18	5.34	4.53	1.08	1.01	1.11	0.03
ed412	0.5	10	3	13.17	0.88	6.97	8.19	7.66	1.09	1.01	2.63	0.02
ed443	0.5	10	3	14.83	0.88	8.08	9.4	8.85	1.08	1.01	2.79	0.02
ed490	0.5	10	3	31.76	0.76	8.64	9.93	9.42	1.08	1.01	19.47	0.06
ed510	0.5	10	11	9.42	0.98	7.75	9.18	8.2	1.06	1	1.1	0.03
ed555	0.5	10	11	8.64	0.96	5.46	7.8	6.33	1.12	1.01	1.1	0.03
lu380	0.5	10	11	0.12	0.94	0.06	0.1	0.08	1.15	1.02	1.02	0.01
lu412	0.5	10	11	0.16	0.95	0.1	0.14	0.12	1.11	1.01	1.02	0.01
lu443	0.5	10	11	0.16	0.96	0.1	0.13	0.12	1.1	1.01	1.02	0.01
lu490	0.5	10	11	0.14	0.96	0.1	0.12	0.11	1.09	1.01	1.02	0.01
lu510	0.5	10	11	0.09	0.96	0.06	0.08	0.07	1.11	1.01	1.02	0.01
lu555	0.5	10	11	0.04	0.94	0.02	0.03	0.03	1.16	1.02	1.03	0.01
lu683	0.5	10	11	0	0.87	0	0	0	1.4	1.12	1.22	0.06

channel	min depth	max depth	n points	b0	b1	min	max	mean	std dev	var	uncertainty	abdev
16 Upcast												
ed380	0.5	10	10	4.54	0.94	3.34	4.46	3.73	1.11	1.01	1.09	0.04
ed412	0.5	10	10	6.82	0.94	5.23	6.71	5.74	1.09	1.01	1.09	0.04
ed443	0.5	10	10	7.8	0.94	5.97	7.65	6.56	1.09	1.01	1.09	0.04
ed490	0.5	10	10	8.14	0.95	6.29	7.97	6.9	1.09	1.01	1.09	0.04
ed510	0.5	10	10	7.93	0.93	5.79	7.64	6.47	1.11	1.01	1.09	0.04
ed555	0.5	10	10	7.36	0.91	4.69	6.82	5.49	1.15	1.02	1.09	0.04
lu380	0.5	10	17	0.07	0.96	0.04	0.07	0.06	1.13	1.02	1.01	0.01
lu412	0.5	10	16	0.09	0.97	0.07	0.09	0.08	1.08	1.01	1.01	0.01
lu443	0.5	10	16	0.09	0.98	0.07	0.09	0.08	1.07	1	1.01	0.01
lu490	0.5	10	16	0.08	0.98	0.07	0.08	0.07	1.06	1	1.01	0.01
lu510	0.5	10	16	0.05	0.97	0.04	0.05	0.05	1.08	1.01	1.01	0.01
lu555	0.5	10	16	0.02	0.95	0.01	0.02	0.02	1.14	1.02	1.02	0.01
lu683	0.5	10	10	0	0.74	0	0	0	1.56	1.22	1.17	0.07

X. Appendix C - Example Profile Header Information

The following text is an example of the header information found in each BBOP processed profile file.

```
<cruise_info>
filename p971104b
date 11-04-1997
day_of_year 308
day_since_010192 2135
file_created 14:18:56
cruise station 8
position 32 23.971 79 28.549
longitude 32 23.971
latitude 79 28.549
sky_state clear
operator_name ajit
sun_position 4
cruise_id sargasso sea nov97sar
session_started 14:19:58
session_stopped 14:26:14
depth_offset 0.32
transmiss_offset 0.0032
trans_air_calib 4.711
trans_factory_air_calib 4.711
trans_sn 664
most_recent_dark_file p971104b
deck_comparison_file p971104b
cal_date_uw9643 021097
cal_date_sfc9644 021097
downcast_ended 14:21:52.960 174
upcast_ended 14:26:13.859 592
yoyo n
closest_CTD_cast y
sun_intensity bright
cloud_type none
cloud_amt none
wind_speed_and_dir
swell
collection_software_version prrprof_002086c
number_units 1
collection_cal_file 96439644.cfl;pr-600 #9643/9644 calibration file 2/10/97 cac
lcd_calib_file 0 /csc/nep1/coors/bbops/BUILD/calib/unit0_021097.cfl
1 /csc/nep1/coors/bbops/BUILD/calib/unit1_021097.cfl
2 /csc/nep1/coors/bbops/BUILD/calib/unit2_021097.cfl
```

lcdfile_created Dec 31 1997 11:18:19

castid	index	lprrr_record	ldepth	
p971104b	dt1	1.7000000e+01	1.7000000e+01	1.5757800e+00
p971104b	db1	1.6800000e+02	1.6800000e+02	2.1253700e+01
p971104b	ub1	2.0500000e+02	2.0500000e+02	2.1342400e+01
p971104b	ut1	3.9700000e+02	3.9700000e+02	1.3916800e-01

<sampled_parameters>

lprrr_record 1 1 0
1Ed380 0 -0.008317 0.000146
1Ed412 0 -0.021345 0.000551
1Ed443 0 -0.021874 0.000189
1Ed490 0 -0.02298 0.000282
1Ed510 0 -0.022313 0.000171
1Ed555 0 -0.022801 0.00048
1PAR 0 -9.05594 0.000371
1EdGND 0 1 0
1Temp 0 0.1421 0.0889
1Depth 0 0.9383 83.1773 26.9099 0 0
1Xmiss 0 0.05 0
1QSP 0 -1.02e-17 0.0018
1Tilt 0 0.04178 2.68617
1Roll 0 0.041514 2.69727
1Scat 0 1 0
1Fluor 0 1 0
2Lu380 0 -0.151929 0.000198
2Lu412 0 -0.498479 -0.000103
2Lu443 0 -0.90121 0.000203
2Lu490 0 -0.996381 0.00016
2Lu510 0 -1.24348 0.00033
2Lu555 0 -1.74733 0.000162
2Lu683 0 -1.52118 0.000105
2LuGnd 0 1 0
3Es380 0 -0.031424 0.00024
3Es412 0 -0.03211 -0.000879
3Es443 0 -0.033785 -2.1e-05
3Es490 0 -0.032938 -0.000256
3Es510 0 -0.032641 -0.000241
3Es555 0 -0.032326 0.000203
3PAR 0 -10.5311 -6.9e-05
3EdGND 0 1 0

<derived_parameters>

aq-1Tilt-1Roll
kq-1ed412
d-1fluor
d-1temp

d-1xmiss
d-d-1fluor
d-d-1temp
d-d-1xmiss
m-d-d-1temp
bin_0.5_1depth
ptsbin_0.5
kc-1ed380
kc-1ed412
kc-1ed443
kc-1ed490
kc-1ed510
kc-1ed555
kc-1par
<data>

<filters_used>

bbopradq -fa 1ed380 6.327000e-03 p971104b.lcd outqp971104b.lcd
bbopradq -fa 1ed412 1.000000e-03 p971104b.lcd outqp971104b.lcd
bbopradq -fa 1ed443 8.000000e-04 p971104b.lcd outqp971104b.lcd
bbopradq -fa 1ed490 1.000000e-03 p971104b.lcd outqp971104b.lcd
bbopradq -fa 1ed510 1.000000e-03 p971104b.lcd outqp971104b.lcd
bbopradq -fa 1ed555 1.000000e-03 p971104b.lcd outqp971104b.lcd
bbopradq -fa 3es380 1.000000e-04 p971104b.lcd outqp971104b.lcd
bbopradq -fa 3es412 1.000000e-03 p971104b.lcd outqp971104b.lcd
bbopradq -fa 3es443 1.000000e-03 p971104b.lcd outqp971104b.lcd
bbopradq -fa 3es490 1.000000e-05 p971104b.lcd outqp971104b.lcd
bbopradq -fa 3es510 1.000000e-05 p971104b.lcd outqp971104b.lcd
bbopradq -fa 3es555 1.000000e-04 p971104b.lcd outqp971104b.lcd
bbopradq -fa 3par 2.000000e-05 p971104b.lcd outqp971104b.lcd
bbopradq -fa 2lu380 8.000000e-05 p971104b.lcd outqp971104b.lcd
bbopradq -fa 2lu412 6.000000e-05 p971104b.lcd outqp971104b.lcd
bbopradq -fa 2lu443 5.000000e-05 p971104b.lcd outqp971104b.lcd
bbopradq -fa 2lu490 1.000000e-05 p971104b.lcd outqp971104b.lcd
bbopradq -fa 2lu510 5.000000e-05 p971104b.lcd outqp971104b.lcd
bbopradq -fa 2lu555 3.000000e-05 p971104b.lcd outqp971104b.lcd
bbopradq -fa 2lu683 1.000000e-08 p971104b.lcd outqp971104b.lcd
bbopradq -fa 1xmiss 3.000000e+01 p971104b.lcd outqp971104b.lcd
bbopradq -fa 1fluor 1.000000e-03 p971104b.lcd outqp971104b.lcd
bbopangq 1Tilt 1Roll 10 2 inqp971104b.lcd outqp971104b.lcd
bbopkq -s led412 3 5 0.5 inqp971104b.lcd outqp971104b.lcd
bbopdespike -d 1fluor 0.03 10 indqp971104b.lcd outdqp971104b.lcd
bbopdespike -d 1temp 0.05 10 indqp971104b.lcd outdqp971104b.lcd
bbopdespike -d 1xmiss 0.05 10 indqp971104b.lcd outdqp971104b.lcd
bbopdespike -d d-1fluor 0.03 10 indqp971104b.lcd outdqp971104b.lcd

bbopdespike -d d-1temp 0.05 10 indqp971104b.lcd outdqp971104b.lcd
bbopdespike -d d-1xmiss 0.05 10 indqp971104b.lcd outdqp971104b.lcd
bbopmovavg -f d-d-1temp 5.0 dqp971104b.lcd mdqp971104b.lcd
bbopbin -b 0.5 mdqp971104b.lcd

bbopkc -s led380 5 inkbmdqp971104b.lcd.2 outkbmdqp971104b.lcd.2
bbopkc -s led412 5 inkbmdqp971104b.lcd.2 outkbmdqp971104b.lcd.2
bbopkc -s led443 5 inkbmdqp971104b.lcd.2 outkbmdqp971104b.lcd.2
bbopkc -s led490 5 inkbmdqp971104b.lcd.2 outkbmdqp971104b.lcd.2
bbopkc -s led510 5 inkbmdqp971104b.lcd.2 outkbmdqp971104b.lcd.2
bbopkc -s led555 5 inkbmdqp971104b.lcd.2 outkbmdqp971104b.lcd.2
bbopkc -s 1par 5 inkbmdqp971104b.lcd.2 outkbmdqp971104b.lcd.2

XI. Appendix D - Calibration Certificates

The following pages contain the calibration certificates for the PRR600s system.

Biospherical Instruments Inc.
CALIBRATION CERTIFICATE for PRR Spectroradiometer

DO NOT DESTROY
 Biospherical Instruments Inc.
 CALIBRATION DATA

Calibration Date: 1/23/96
 Model Number: PRV-600S
 Serial Number: 9643
 Operator: JCE/LFG
 Standard Lamp: 91771 (05/30/95)

Form: 1/24/96

Ch	Tag	λ (nm)	Lamp Irradiance	Immersion Coefficient	Calibration Voltage - Dark ³⁾	Calibration Voltage - Light	Calibration Factor - Dry (V/ μ W)	Calibration Factor - Wet (V/ μ W)	Max E (Dry)
DOWNWELLING IRRADIANCE CHANNELS									
Irradiance Units: μ W/cm ² -nm, E = Irradiance									
1	0	380	1.397	0.671	0.000132	-0.018129	-0.013074	-0.008775	764.9
2	0	412	2.411	0.677	0.000516	-0.077541	-0.032371	-0.021906	308.9
3	0	443	3.701	0.682	0.000113	-0.120950	-0.032714	-0.022313	305.7
4	0	490	6.159	0.690	0.000302	-0.209334	-0.034039	-0.023491	293.8
5	0	510	7.302	0.694	0.000168	-0.240489	-0.032957	-0.022859	303.4
6	0	555	10.041	0.701	0.000465	-0.332822	-0.033194	-0.023279	301.3
7	0	PAR ⁴⁾	0.014	0.686	0.000330	-0.194557	-13.767821	-9.442522	0.726 ⁴⁾
8	0	Gnd. ⁵⁾	0.000291	Voits					

Calibration Factor: WET = ((Light - Dark) x Immers. Coeff.)/Lamp Output
 DRY = (Light - Dark)/Lamp Output

Ch	Tag	λ (nm)	Lamp Irradiance @ 50 cm	Immersion Coefficient	Plaque Reflectivity	Radiance ⁶⁾	Calibration Voltage - Dark	Calibration Voltage - Blocked ³⁾	Calibration Voltage - Light	Calibration Factor - Wet (V/ μ W)	Max L (Wet)
UPWELLING RADIANCE CHANNELS											
Radiance Units: μ W/cm ² -nm-sr, L = Radiance											
1	1	380	1.397	1.765	0.985	0.012	0.000221	0.000214	-0.003021	-0.150639	66.4
2	1	412	2.411	1.758	0.985	0.021	-0.000068	-0.000079	-0.018727	-0.505131	19.8
3	1	443	3.701	1.752	0.985	0.032	0.000233	0.000215	-0.050659	-0.900887	11.1
4	1	490	6.159	1.745	0.984	0.054	0.000180	0.000150	-0.092345	-0.988998	10.1
5	1	510	7.302	1.743	0.984	0.064	0.000363	0.000337	-0.136471	-1.235454	8.1
6	1	555	10.041	1.738	0.984	0.087	0.000180	0.000128	-0.263356	-1.734900	5.8
7	1	683	16.897	1.730	0.984	0.147	0.000095	-0.000003	-0.394184	-1.550051	6.5
8	1	Gnd. ⁵⁾	0.00019	Voits							

Dry Radiance = (Lamp Output x Plaque Reflectivity x Lamp Distance Factor)/ π
 Lamp Distance Factor = (50 cm)²/(300 cm)²
 Calibration Factor: WET = (Light - Dark)/(Dry Radiance x Immersion Coefficient)

9	0	TEMPERATURE ⁷⁾	Temperature (°C) = (Voltage - Offset)/Scale								
		Scale	0.1419								
		Offset	0.0801								
10	0	PRESSURE/DEPTH ⁸⁾	Pressure/Depth (dbars or meters) = (a x Voltage ²) + (b x Voltage) + c								
		Scale Factor "a"	0.9374								
		Scale Factor "b"	83.8842								
		Offset "c"	26.9635								

NOMINAL TO ACTUAL VOLTAGE CONVERSION FACTORS (For use with external sensors, only, see manual)

	Irr. Array	Rad. Array
Scale Factor	1.057679	1.074227
Offset	0.000205	0.000278
Full Scale Voltage	9.4547	9.3090

FIRMWARE VERSIONS

	Tag 0	Tag 1
Underwater ROM	2765B	2043A

Notes:

- Annual calibration is recommended.
- Calibrations were performed at approximately 20 to 30 °C.
- "Dark" irradiance and "Blocked" radiance values represent a blocking of the calibration source. These values should not be used as the "Offset" when entering values into the calibration file. Use the totally dark sensor values obtained at the temperature where the instrument will be used.
- PAR irradiance units are μ Einsteins/cm²-sec.
- Typical value(s).
- For conversion of area to solid angle, a factor (divisor) of Pi is incorporated.
- Water temperature sensor.
- A change in depth of 1 meter in seawater corresponds to approximately a 1 dbar change in pressure.

DO NOT DESTROY
 Biospherical Instruments Inc.
 CALIBRATION DATA

Biospherical Instruments Inc.
CALIBRATION CERTIFICATE for PRR Spectroradiometer

Calibration Date: 1/23/96 Form: 1/24/96
 Model Number: PRV-600S
 Serial Number: 9643
 Operator: JCE/LFG

OPTIONAL CHANNELS

Ch	Tag	Output = (Voltage - Offset)/Scale		
11	0 Transmissometer ¹⁾			
	Scale Factor	<table border="1" style="display: inline-table;"><tr><td style="text-align: center;">1.0</td><td style="text-align: left;">Volts/Volt</td></tr></table>	1.0	Volts/Volt
1.0	Volts/Volt			
	Offset	<table border="1" style="display: inline-table;"><tr><td style="text-align: center;">0.0</td><td style="text-align: left;">Volts</td></tr></table>	0.0	Volts
0.0	Volts			
12	0 Scalar PAR: QSP-200 S/N 4443			
	Scale Factor (Wet)	<table border="1" style="display: inline-table;"><tr><td style="text-align: center;">-1.161E-17</td><td style="text-align: left;">Volts/(quanta/cm²·sec)</td></tr></table>	-1.161E-17	Volts/(quanta/cm ² ·sec)
-1.161E-17	Volts/(quanta/cm ² ·sec)			
	Offset	<table border="1" style="display: inline-table;"><tr><td style="text-align: center;">0.0009</td><td style="text-align: left;">Volts</td></tr></table>	0.0009	Volts
0.0009	Volts			
13	0 AXIS 1 ANGLE SENSOR - "TILT"			
	Scale Factor	<table border="1" style="display: inline-table;"><tr><td style="text-align: center;">0.0418</td><td></td></tr></table>	0.0418	
0.0418				
	Offset	<table border="1" style="display: inline-table;"><tr><td style="text-align: center;">2.6862</td><td></td></tr></table>	2.6862	
2.6862				
14	0 AXIS 2 ANGLE SENSOR - "ROLL"			
	Scale Factor	<table border="1" style="display: inline-table;"><tr><td style="text-align: center;">0.0415</td><td></td></tr></table>	0.0415	
0.0415				
	Offset	<table border="1" style="display: inline-table;"><tr><td style="text-align: center;">2.6973</td><td></td></tr></table>	2.6973	
2.6973				
15	0 Light Scattering Sensor ¹⁾			
	Scale Factor	<table border="1" style="display: inline-table;"><tr><td style="text-align: center;">1.0</td><td style="text-align: left;">Volts/Volt</td></tr></table>	1.0	Volts/Volt
1.0	Volts/Volt			
	Offset	<table border="1" style="display: inline-table;"><tr><td style="text-align: center;">0.0</td><td style="text-align: left;">Volts</td></tr></table>	0.0	Volts
0.0	Volts			
16	0 Fluorometer ¹⁾			
	Scale Factor	<table border="1" style="display: inline-table;"><tr><td style="text-align: center;">1.0</td><td style="text-align: left;">Volts/Volt</td></tr></table>	1.0	Volts/Volt
1.0	Volts/Volt			
	Offset	<table border="1" style="display: inline-table;"><tr><td style="text-align: center;">0.0</td><td style="text-align: left;">Volts</td></tr></table>	0.0	Volts
0.0	Volts			

Notes:

1) These sensors are not calibrated at BSI. When applicable, see the manufacturers' specifications.

DO NOT DESTROY
Biospherical Instruments Inc.
CALIBRATION DATA

JS

Biospherical Instruments Inc.
CALIBRATION CERTIFICATE for PRR Spectroradiometer

Calibration Date: 1/24/96 Form: 1/25/96
 Model Number: PRV-610
 Serial Number: 9644
 Operator: JCE/LFG
 Standard Lamp: 91771 (05/30/95)

Ch	Tag	λ (nm)	Lamp Output	Calibration Voltage - Dark ³⁾	Calibration Voltage - Light	Calibration Factor - Dry (V/ μ W)	Max E (Dry)
SURFACE IRRADIANCE CHANNELS							
Irradiance Units: μ W/cm ² -nm, E = Irradiance							
1	2	380	1.397	0.000205	-0.045775	-0.032918	303.8
2	2	412	2.411	-0.000888	-0.079748	-0.032704	305.8
3	2	443	3.701	-0.000036	-0.126600	-0.034201	292.4
4	2	490	6.159	-0.000291	-0.206142	-0.033424	299.2
5	2	510	7.302	-0.000277	-0.242508	-0.033173	301.5
6	2	555	10.041	0.000142	-0.328101	-0.032691	305.9
7	2	PAR ⁴⁾	0.0142	-0.000040	-0.153967	-10.874195	0.920 ⁴⁾
8	2	Gnd. ⁵⁾	0.000095	Volts			

Calibration Factors: DRY = (Light - Dark)/Lamp Output

NOMINAL TO ACTUAL VOLTAGE CONVERSION FACTORS (For use with external sensors, only, see manual)

	Irr. Array
Scale	1.061494
Offset	0.000049
Full Scale Voltage	9.4207

FIRMWARE VERSION

	Tag 2
Surface ROM	2106B

Notes:

1. Annual calibration is recommended.
2. Calibrations were made at approximately 20 to 30 °C.
- 3) Dark values represent a blocking of the calibration source. These values should not be used as the 'offset' when entering values into the calibration file. Use the totally dark sensor values obtained at the temperature where the instrument will be used.
- 4) PAR irradiance units are μ Einsteins/cm².sec.
- 5) Typical value(s).

Biospherical Instruments Inc.
EVALUATION FORM for PRR Spectroradiometer

Calibration Date: 3/28/96 Form: 7/11/96
 Model Number: PRV-600S
 Serial Number: 9643
 Operator: JCE/LFG
 Standard Lamp: 94531 (10/11/95) for Irradiance, 94532 (10/11/95) for Radiance.

Ch Tag	λ (nm)	Lamp Irradiance	Immersion Coefficient	Calibration Voltage - Dark ³⁾	Calibration Voltage - Light	Calibration Factor - Dry (V/ μ W)	Calibration Factor - Wet (V/ μ W)	Max E (Dry)	
DOWNWELLING IRRADIANCE CHANNELS Irradiance Units: μ W/cm ² ·nm, E = Irradiance									
1	0	380	1.486	0.000160	-0.019050	-0.012927	-0.008677	773.6	
2	0	412	2.559	0.000095	-0.081553	-0.031907	-0.021592	313.4	
3	0	443	3.906	0.000116	-0.126520	-0.032421	-0.022113	308.4	
4	0	490	6.483	0.000272	-0.218429	-0.033732	-0.023280	296.5	
5	0	510	7.683	0.000108	-0.250415	-0.032609	-0.022617	306.7	
6	0	555	10.536	0.000459	-0.345228	-0.032809	-0.023010	304.8	
7	0	PAR ⁴⁾	0.0152	0.000337	-0.200664	-13.196577	-9.050741	0.758 ⁴⁾	
8	0	Gnd. ⁵⁾	0.000309	Volts					

Calibration Factor: WET = ((Light - Dark) x Immers. Coeff.)/Lamp Output
 DRY = (Light - Dark)/Lamp Output

Ch Tag	λ (nm)	Lamp Irradiance @ 50 cm	Immersion Coefficient	Plaque Reflectivity	Radiance ⁶⁾	Calibration Voltage - Dark	Calibration Voltage - Blocked ³⁾	Calibration Voltage - Light	Calibration Factor - Wet (V/ μ W)	Max L (Wet)	
UPWELLING RADIANCE CHANNELS Radiance Units: μ W/cm ² ·nm·sr, L = Radiance											
1	1	380	1.308	1.765	0.985	0.011	0.000133	0.000133	-0.002922	-0.151959	65.8
2	1	412	2.275	1.758	0.985	0.020	0.000209	0.000202	-0.017559	-0.509911	19.6
3	1	443	3.514	1.752	0.985	0.031	0.000192	0.000186	-0.048678	-0.911266	11.0
4	1	490	5.911	1.745	0.984	0.051	0.000122	0.000108	-0.090184	-1.005825	9.9
5	1	510	7.038	1.743	0.984	0.061	0.000272	0.000261	-0.133038	-1.248987	8.0
6	1	555	9.746	1.738	0.984	0.085	0.000124	0.000083	-0.258677	-1.755312	5.7
7	1	683	16.755	1.730	0.984	0.146	0.000027	-0.000057	-0.392216	-1.555169	6.4
8	1	Gnd. ⁵⁾	0.000124	Volts							

Dry Radiance = (Lamp Output x Plaque Reflectivity x Lamp Distance Factor)/ π
 Lamp Distance Factor = (50 cm)²/(300 cm)²
 Calibration Factor: WET = (Light - Dark)/(Dry Radiance x Immersion Coefficient)

9	0	TEMPERATURE ^{7, 8)}	Temperature (°C) = (Voltage - Offset)/Scale							
		Scale	0.1419							
		Offset	0.0801							
10	0	PRESSURE/DEPTH ^{8, 9)}	Pressure/Depth (dbars or meters) = (a x Voltage ²) + (b x Voltage) + c							
		Scale Factor "a"	0.9374							
		Scale Factor "b"	83.8842							
		Offset "c"	26.9635							

NOMINAL TO ACTUAL VOLTAGE CONVERSION FACTORS⁹⁾ (For use with external sensors, only, see manual)

	Irr. Array	Rad. Array
Scale Factor	1.057679	1.074227
Offset	0.000206	0.000278
Full Scale Voltage	9.4547	9.3090

FIRMWARE VERSIONS

	Tag 0	Tag 1
Underwater ROM	2765B	2043A

Notes:

- Annual calibration is recommended.
- Calibrations were performed at approximately 20 to 30 °C.
- "Dark" irradiance and "Blocked" radiance values represent a blocking of the calibration source. These values should not be used as the "Offset" when entering values into the calibration file. Use the totally dark sensor values obtained at the temperature where the instrument will be used.
- PAR irradiance units are μ Einsteins/cm²·sec.
- Nominal/Typical value(s).
- For conversion of area to solid angle, a factor (divisor) of π is incorporated.
- Water temperature sensor.
- A change in depth of 1 meter in seawater corresponds to approximately a 1 dbar change in pressure.
- These channels/sensors were not evaluated during this service period.

Biospherical Instruments Inc.
CALIBRATION CERTIFICATE for PRR Spectroradiometer

Calibration Date: 3/26/96
 Model Number: PRV-600S
 Serial Number: 9643
 Operator: JCE/LFG

Form: 7/11/96

OPTIONAL CHANNELS

Ch Tag

11	0	Transmissometer ¹⁾	Output = (Voltage - Offset)/Scale
		Scale Factor	1.0 Volts/Volt
		Offset	0.0 Volts
12	0	Scalar PAR: QSP-200 S/N 4443 ²⁾	quanta/(cm ² ·sec) = (Voltage - Offset)/Scale
		Scale Factor (Wet)	-1.161E-17 Volts/(quanta/cm ² ·sec)
		Offset	0.0009 Volts
13	0	AXIS 1 ANGLE SENSOR - "TILT" ²⁾	Degrees = (Voltage - Offset)/Scale
		Scale Factor	0.0418
		Offset	2.8862
14	0	AXIS 2 ANGLE SENSOR - "ROLL" ²⁾	Degrees = (Voltage - Offset)/Scale
		Scale Factor	0.0415
		Offset	2.8973
15	0	Light Scattering Sensor ¹⁾	Output = (Voltage - Offset)/Scale
		Scale Factor	1.0 Volts/Volt
		Offset	0.0 Volts
16	0	Fluorometer ¹⁾	Output = (Voltage - Offset)/Scale
		Scale Factor	1.0 Volts/Volt
		Offset	0.0 Volts

Notes:

- 1) These sensors are not calibrated at BSI. When applicable, see the manufacturers' specifications.
- 2) These channels/sensors were not evaluated during this service period.

Biospherical Instruments Inc.
CALIBRATION CERTIFICATE for PRR Spectroradiometer

DO NOT DESTROY
 Biospherical Instruments Inc.
 CALIBRATION DATA

Calibration Date: 2/10/97 Form: 2/10/97
 Model Number: PRV-600S
 Serial Number: 9643
 Operator: TMM

Standard Lamp: 94531 (01/02/97) for Irradiance, 94532 (10/11/95) for Radiance.

Ch Tag	λ (nm)	Lamp Irradiance	Immersion Coefficient	Calibration Voltage - Dark ³⁾	Calibration Voltage - Light	Calibration Factor - Dry (V/ μ W)	Calibration Factor - Wet (V/ μ W)	Max E (Dry)	
DOWNWELLING IRRADIANCE CHANNELS Irradiance Units: μ W/cm ² -nm, E = Irradiance									
1	0	380	1.578	0.671	0.000146	-0.019400	-0.012390	-0.008317	807.1
2	0	412	2.595	0.677	0.000551	-0.081300	-0.031541	-0.021345	317.0
3	0	443	4.003	0.682	0.000189	-0.128186	-0.032071	-0.021874	311.8
4	0	490	6.647	0.690	0.000282	-0.221058	-0.033297	-0.022980	300.3
5	0	510	7.880	0.694	0.000171	-0.253324	-0.032171	-0.022313	310.8
6	0	555	10.730	0.701	0.000480	-0.348378	-0.032511	-0.022801	307.6
7	0	PAR ⁴⁾	0.0154	0.686	0.000371	-0.202865	-13.204159	-9.055940	0.757 ⁴⁾
8	0	Gnd. ⁵⁾	0.000318	Volts					

Calibration Factor: WET = ((Light - Dark) x Immers. Coeff.)/Lamp Output
 DRY = (Light - Dark)/Lamp Output

Ch Tag	λ (nm)	Lamp Irradiance @ 50 cm	Immersion Coefficient	Plaque Reflectivity	Radiance ⁶⁾	Calibration Voltage - Dark	Calibration Voltage - Blocked ³⁾	Calibration Voltage - Light	Calibration Factor - Wet (V/ μ W)	Max L (Wet)	
UPWELLING RADIANCE CHANNELS Radiance Units: μ W/cm ² -nm-sr, L = Radiance											
1	1	380	1.308	1.765	0.988	0.011	0.000198	0.000206	-0.002858	-0.151929	65.8
2	1	412	2.275	1.758	0.989	0.020	-0.000103	-0.000098	-0.017526	-0.498479	20.1
3	1	443	3.514	1.752	0.990	0.031	0.000203	0.000203	-0.048370	-0.901210	11.1
4	1	490	5.911	1.745	0.990	0.052	0.000160	0.000151	-0.089873	-0.996381	10.0
5	1	510	7.038	1.743	0.990	0.062	0.000330	0.000321	-0.133200	-1.243485	8.0
6	1	555	9.746	1.738	0.991	0.085	0.000162	0.000123	-0.259162	-1.747331	5.7
7	1	683	16.755	1.730	0.990	0.147	0.000105	0.000026	-0.385980	-1.521184	6.6
8	1	Gnd. ⁵⁾	0.000179	Volts							

Dry Radiance = (Lamp Output x Plaque Reflectivity x Lamp Distance Factor)/ π
 Lamp Distance Factor = (50 cm)²/(300 cm)²
 Calibration Factor: WET = (Light - Dark)/(Dry Radiance x Immersion Coefficient)

9	0	TEMPERATURE ^{7, 9)}	Temperature (°C) = (Voltage - Offset)/Scale							
		Scale	0.1421							
		Offset	0.0889							
10	0	PRESSURE/DEPTH ^{8, 9)}	Pressure/Depth (dbars or meters) = (a x Voltage ²) + (b x Voltage) + c							
		Scale Factor "a"	0.9383							
		Scale Factor "b"	83.1773							
		Offset "c"	26.9099							

NOMINAL TO ACTUAL VOLTAGE CONVERSION FACTORS⁹⁾ (For use with external sensors, only, see manual)

	Irr. Array	Rad. Array	
Scale Factor	1.057679	1.074227	(Calibrated on 3-96)
Offset	0.000206	0.000278	
Full Scale Voltage	9.4547	9.3090	

FIRMWARE VERSIONS

	Tag 0	Tag 1
Underwater ROM	2765B	2043A

Notes:

- Annual calibration is recommended.
- Calibrations were performed at approximately 20 to 30 °C.
- "Dark" irradiance and "Blocked" radiance values represent a blocking of the calibration source. These values should not be used as the "Offset" when entering values into the calibration file. Use the totally dark sensor values obtained at the temperature where the instrument will be used.
- PAR irradiance units are μ Einsteins/cm²-sec.
- Nominal/Typical value(s).
- For conversion of area to solid angle, a factor (divisor) of π is incorporated.
- Water temperature sensor.
- A change in depth of 1 meter in seawater corresponds to approximately a 1 dbar change in pressure.
- These channels/sensors were not evaluated during this service period.

DO NOT DESTROY
 Biospherical Instruments Inc.
 CALIBRATION DATA

Biospherical Instruments Inc.
 CALIBRATION CERTIFICATE for PRR Spectroradiometer

Calibration Date: 2/10/97
 Model Number: PRV-600S
 Serial Number: 9643
 Operator: TMM

Form: 2/10/97

OPTIONAL CHANNELS

Ch Tag

11	0	Transmissometer ¹⁾	Output = (Voltage - Offset)/Scale
		Scale Factor	<u>1.0</u> Volts/Volt
		Offset	<u>0.0</u> Volts
12	0	Scalar PAR: QSP-200 S/N 4443 ²⁾	quanta/(cm ² -sec) = (Voltage - Offset)/Scale
		Scale Factor (Wet)	<u>-1.020E-17</u> Volts/(quanta/cm ² -sec)
		Offset	<u>0.0009</u> Volts
13	0	AXIS 1 ANGLE SENSOR - "TILT" ²⁾	Degrees = (Voltage - Offset)/Scale
		Scale Factor	<u>0.0418</u> (Calibrated on 3-96)
		Offset	<u>2.6862</u>
14	0	AXIS 2 ANGLE SENSOR - "ROLL" ²⁾	Degrees = (Voltage - Offset)/Scale
		Scale Factor	<u>0.0415</u> (Calibrated on 3-96)
		Offset	<u>2.6973</u>
15	0	Light Scattering Sensor ¹⁾	Output = (Voltage - Offset)/Scale
		Scale Factor	<u>1.0</u> Volts/Volt
		Offset	<u>0.0</u> Volts
16	0	Fluorometer ¹⁾	Output = (Voltage - Offset)/Scale
		Scale Factor	<u>1.0</u> Volts/Volt
		Offset	<u>0.0</u> Volts

Notes:

- 1) These sensors are not calibrated at BSI. When applicable, see the manufacturers' specifications.
- 2) These channels/sensors were not evaluated during this service period.

DO NOT DESTROY
 Biospherical Instruments Inc.
 CALIBRATION DATA

Biospherical Instruments Inc.
 CALIBRATION CERTIFICATE for PRR Spectroradiometer

Calibration Date: 2/10/97 Form: 2/10/97
 Model Number: PRV-610
 Serial Number: 9644
 Operator: TMM
 Standard Lamp: 95431 (01/02/97)

Ch	Tag	λ (nm)	Lamp Output	Calibration Voltage - Dark ³⁾	Calibration Voltage - Light	Calibration Factor - Dry (V/ μ W)	Max E (Dry)
SURFACE IRRADIANCE CHANNELS							
Irradiance Units: μ W/cm ² -nm, E = Irradiance							
1	2	380	1.578	0.000240	-0.049332	-0.031424	318.2
2	2	412	2.595	-0.000879	-0.084205	-0.032110	311.4
3	2	443	4.003	-0.000021	-0.135255	-0.033785	296.0
4	2	490	6.647	-0.000256	-0.219210	-0.032938	303.6
5	2	510	7.880	-0.000241	-0.257444	-0.032641	306.4
6	2	555	10.730	0.000203	-0.346664	-0.032326	309.4
7	2	PAR ⁴⁾	0.0154	0.000069	-0.162024	-10.531115	0.950 ⁴⁾
8	2	Gnd. ⁵⁾	0.000101	Volts			

Calibration Factors: DRY = (Light - Dark)/Lamp Output

NOMINAL TO ACTUAL VOLTAGE CONVERSION FACTORS (For use with external sensors, only, see manual)

	Irr. Array	
Scale	1.061494	(Calibrated on 1-96)
Offset	0.000049	
Full Scale Voltage	9.4207-	

FIRMWARE VERSION

	Tag 2
Surface ROM	2106B

Notes:

1. Annual calibration is recommended.
2. Calibrations were made at approximately 20 to 30 °C.
- 3) Dark values represent a blocking of the calibration source. These values should not be used as the 'offset' when entering values into the calibration file. Use the totally dark sensor values obtained at the temperature where the instrument will be used.
- 5) Typical value(s).

Biospherical Instruments Inc.
CALIBRATION CERTIFICATE for PRR Spectroradiometer

DO NOT DESTROY
 Biospherical Instruments Inc.
 CALIBRATION DATA

Calibration Date: 1/7/98

Form: 1/8/98

Model Number: PRV-600S

Serial Number: 9643

Operator: TMM/DAN

Standard Lamp: 94531 (01/02/97) for Irradiance, 94532 (10/11/95) for Radiance

Ch	Ta	λ (nm)	Lamp Irradiance @ 50 cm	Immersion Coefficient (Type P6-2)	Calibration Voltage - Dark ³⁾	Calibration Voltage - Light	Calibration Factor - Dry (V/μW)	Calibration Factor - Wet (V/μW)	Max E (Dry)
DOWNWELLING IRRADIANCE CHANNELS									
Irradiance Units: μW/cm ² ·nm, E = Irradiance									
1	0	380	1.578	0.671	0.000216	-0.019687	-0.012617	-0.008469	792.6
2	0	412	2.595	0.677	0.000144	-0.082185	-0.031725	-0.021469	315.2
3	0	443	4.003	0.682	0.000186	-0.129799	-0.032473	-0.022149	307.9
4	0	490	6.647	0.690	0.000293	-0.223611	-0.033683	-0.023246	296.9
5	0	510	7.880	0.694	0.000160	-0.255997	-0.032509	-0.022547	307.6
6	0	555	10.730	0.701	0.000481	-0.351498	-0.032802	-0.023005	304.9
7	0	PAR ⁴⁾	0.01539	0.689	0.000366	-0.204294	-13.296675	-9.158271	0.752 ⁵⁾
8	0	Gnd. ⁷⁾	0.000315	Volts					

Calibration Factor: WET = ((Light - Dark) x Immers. Coeff.)/Lamp Output
 DRY = (Light - Dark)/Lamp Output

Ch	Ta	λ (nm)	Lamp Irradiance @ 50 cm	Immersion Coefficient (BK7 window)	Plaque Reflectivity S/N 20166	Calibration Voltage - Dark	Calibration Voltage - Blocked ³⁾	Calibration Voltage - Light	Calibration Factor - Wet (V/μW)	Max L (Wet)
UPWELLING RADIANCE CHANNELS										
Radiance Units: μW/cm ² ·nm·sr, L = Radiance										
1	1	380	1.308	1.765	0.987	0.011	0.000199	0.000189	-0.002868	64.9
2	1	412	2.275	1.758	0.990	0.020	-0.000094	-0.000102	-0.017453	19.9
3	1	443	3.514	1.752	0.991	0.030	0.000239	0.000220	-0.048862	10.8
4	1	490	5.911	1.745	0.991	0.051	0.000197	0.000169	-0.090176	9.9
5	1	510	7.038	1.743	0.991	0.061	0.000331	0.000308	-0.133501	7.9
6	1	555	9.746	1.738	0.991	0.084	0.000171	0.000118	-0.260191	5.6
7	1	683	16.755	1.730	0.991	0.145	0.000091	0.000001	-0.383667	6.5
8	1	Gnd. ⁷⁾	0.000164	Volts						

Dry Radiance = (Lamp Output x Plaque Reflectivity x Lamp Distance Factor)/π
 Lamp Distance Factor = (50 cm)²/(300 cm)²

Calibration Factor: WET = (Light - Dark)/(Dry Radiance x Immersion Coefficient)

9	0	TEMPERATURE⁷⁾		Temperature (°C) = (Voltage - Offset)/Scale						
		Scale		0.1419						
		Offset		0.0919						
10	0	PRESSURE/DEPTH⁸⁾		Pressure/Depth (dbars or meters) = (a x Voltage²) + (b x Voltage) + c						
		Scale Factor "a"		0.9298						
		Scale Factor "b"		83.3548						
		Offset "c"		26.8924						

NOMINAL TO ACTUAL VOLTAGE CONVERSION FACTORS (For use with external sensors, only, see manual)

	Irr. Array	Rad. Array
Scale Factor	1.057679	1.074227
Offset	0.000205	0.000278
Full Scale Voltage	9.4547	9.3090

FIRMWARE VERSION(S)

	Tag 0	Tag 1
Underwater ROM	2765B	2043A

Notes:

- Annual calibration is recommended.
- Calibrations were performed at approximately 20 to 30 °C.
- "Dark" irradiance and "Blocked" radiance values represent a blocking of the calibration source. These values should not be used as the "Offset" when entering values into the calibration file. Use the totally dark sensor values obtained at the temperature where the instrument will be used.
- PAR irradiance units are μEinstein/cm²·sec.
- Nominal/Typical value(s).
- For conversion of area to solid angle, a factor (divisor) of Pi is incorporated.
- Water temperature sensor.
- A change in depth of 1 meter in seawater corresponds to approximately a 1 dbar change in pressure.

DO NOT DESTROY
 Biospherical Instruments Inc.
 CALIBRATION DATA

TMM

Biospherical Instruments Inc.
CALIBRATION CERTIFICATE for PRR Spectroradiometer

Calibration Date: 1/7/98 Form: 1/8/98
 Model Number: PRV-600S
 Serial Number: 9643
 Operator: TMM/DAN

OPTIONAL CHANNELS

Ch Tag			
11	0 Transmissometer ¹⁾	Output = (Voltage - Offset)/Scale	
	Scale Factor	1.0	Volts/Volt
	Offset	0.0	Volts
12	0 Scalar PAR: QSP-200 S/N 4443 ²⁾	quanta/(cm ² -sec) = (Voltage - Offset)/Scale	
	Scale Factor (Wet)	-1.020E-17	Volts/(quanta/cm ² -sec)
	Offset	0.0009	Volts
13	0 AXIS 1 ANGLE SENSOR - "TILT" ²⁾	Degrees = (Voltage - Offset)/Scale	
	Scale Factor	0.0418	
	Offset	2.6862	
14	0 AXIS 2 ANGLE SENSOR - "ROLL" ²⁾	Degrees = (Voltage - Offset)/Scale	
	Scale Factor	0.0415	
	Offset	2.6973	
15	0 Light Scattering Sensor ¹⁾	Output = (Voltage - Offset)/Scale	
	Scale Factor	1.0	Volts/Volt
	Offset	0.0	Volts
16	0 Fluorometer ¹⁾	Output = (Voltage - Offset)/Scale	
	Scale Factor	1.0	Volts/Volt
	Offset	0.0	Volts

Notes:
 1) These sensors are not calibrated at BSI. When applicable, see the manufacturers' specifications.
 2) These channels/sensors were not evaluated during this service period.

DO NOT DESTROY
 Biospherical Instruments Inc.
 CALIBRATION DATA

Biospherical Instruments Inc.
 CALIBRATION CERTIFICATE for PRR Spectroradiometer

Calibration Date: ~~2/10/97~~ ^{uCC} 1/7/98 Form: 1/8/98
 Model Number: PRV-610
 Serial Number: 9644
 Operator: TMM/DAN
 Standard Lamp: 95431 (01/02/97)

Ch	Tag	λ (nm)	Lamp Output	Calibration Voltage - Dark ³⁾	Calibration Voltage - Light	Calibration Factor - Dry (V/ μ W)	Max E (Dry)
SURFACE IRRADIANCE CHANNELS							
Irradiance Units: μ W/cm ² ·nm, E = Irradiance							
1	2	380	1.578	0.000250	-0.050046	-0.031883	313.6
2	2	412	2.595	-0.000869	-0.084474	-0.032217	310.4
3	2	443	4.003	-0.000011	-0.136253	-0.034036	293.8
4	2	490	6.647	-0.000248	-0.221013	-0.033211	301.1
5	2	510	7.880	-0.000220	-0.259113	-0.032856	304.4
6	2	555	10.730	0.000225	-0.348584	-0.032507	307.6
7	2	PAR ⁴⁾	0.0154	0.000105	-0.161913	-10.526242	0.950 ⁴⁾
8	2	Gnd. ⁵⁾	0.000105	Volts			

Calibration Factors: DRY = (Light - Dark)/Lamp Output

NOMINAL TO ACTUAL VOLTAGE CONVERSION FACTORS (For use with external sensors, only, see manual)

	Irr. Array
Scale	1.061494
Offset	0.000049
Full Scale Voltage	9.4207

FIRMWARE VERSION

	Tag 2
Surface ROM	2106B

Notes:

- Annual calibration is recommended.
- Calibrations were made at approximately 20 to 30 °C.
- Dark values represent a blocking of the calibration source. These values should not be used as the 'offset' when entering values into the calibration file. Use the totally dark sensor values obtained at the temperature where the instrument will be used.
- PAR irradiance units are μ Einsteins/cm²·sec.
- Typical value(s).

XII. Appendix E – Backscattering Coefficient Profile Data Figures

Figure E.1.a - Station 7 Downcast

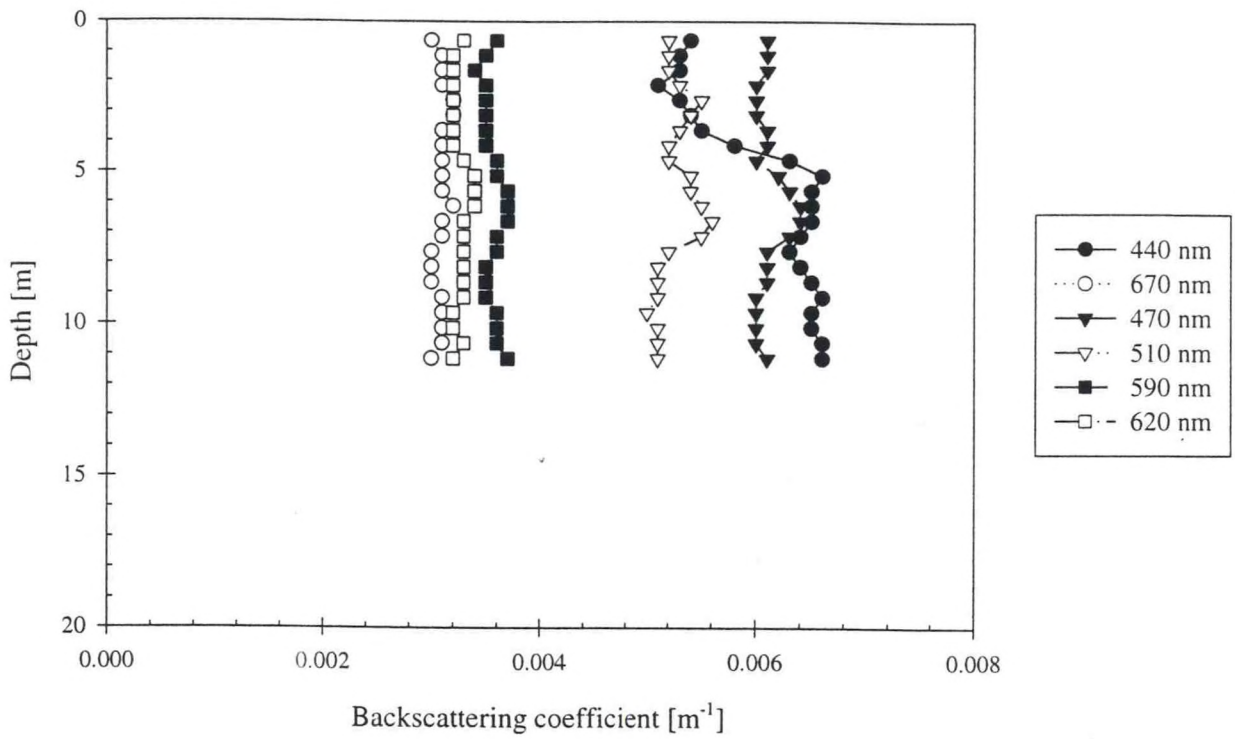

Figure E.1.b - Station 7 Upcast

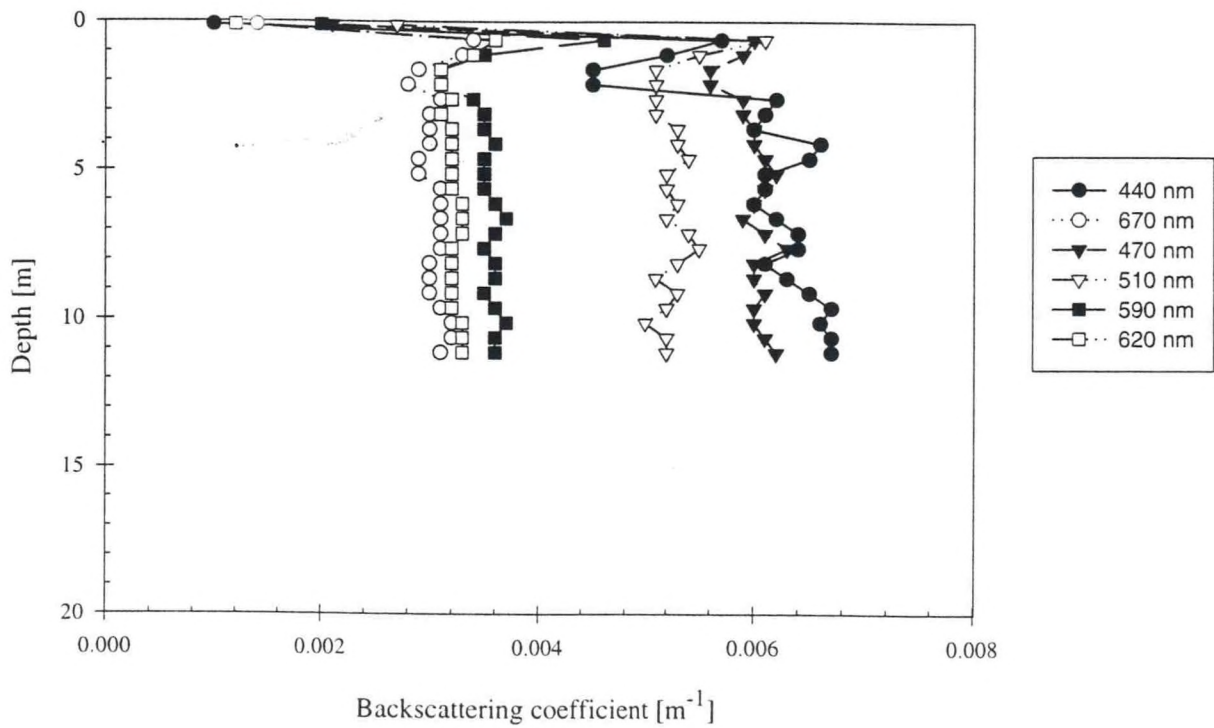

Figure E.2.a - Station 8 Downcast

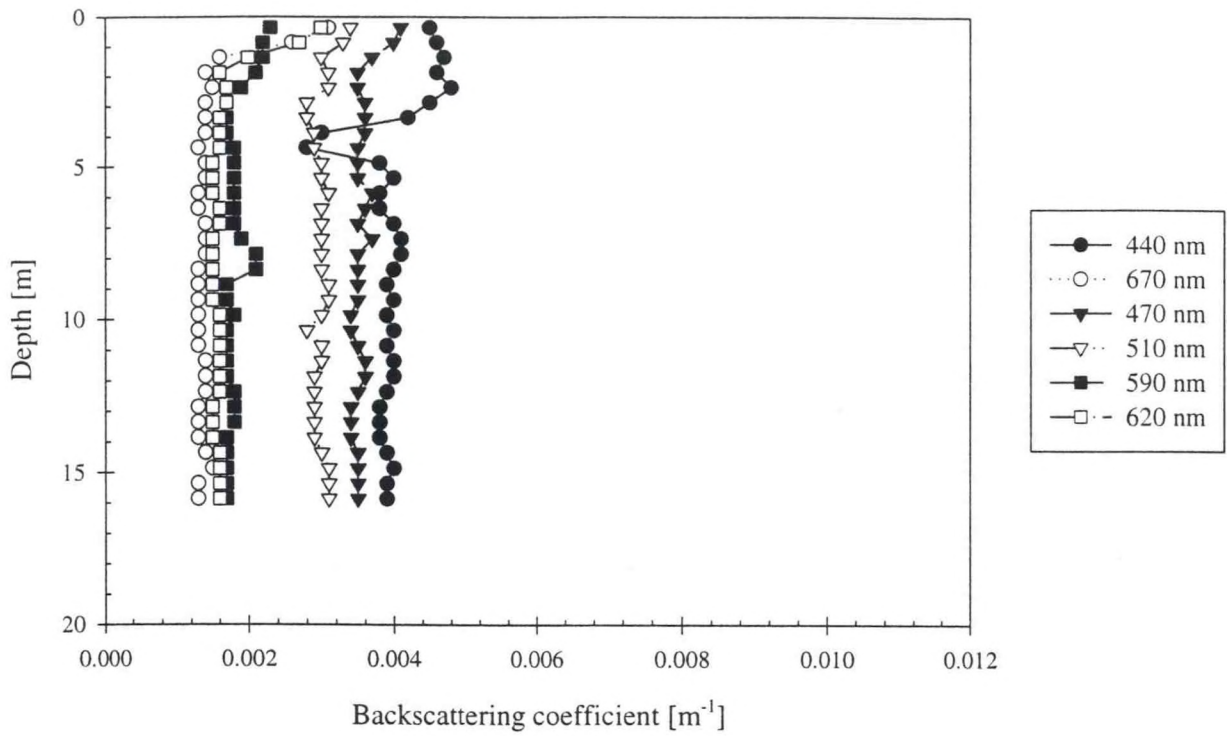

Figure E.2.b - Station 8 Upcast

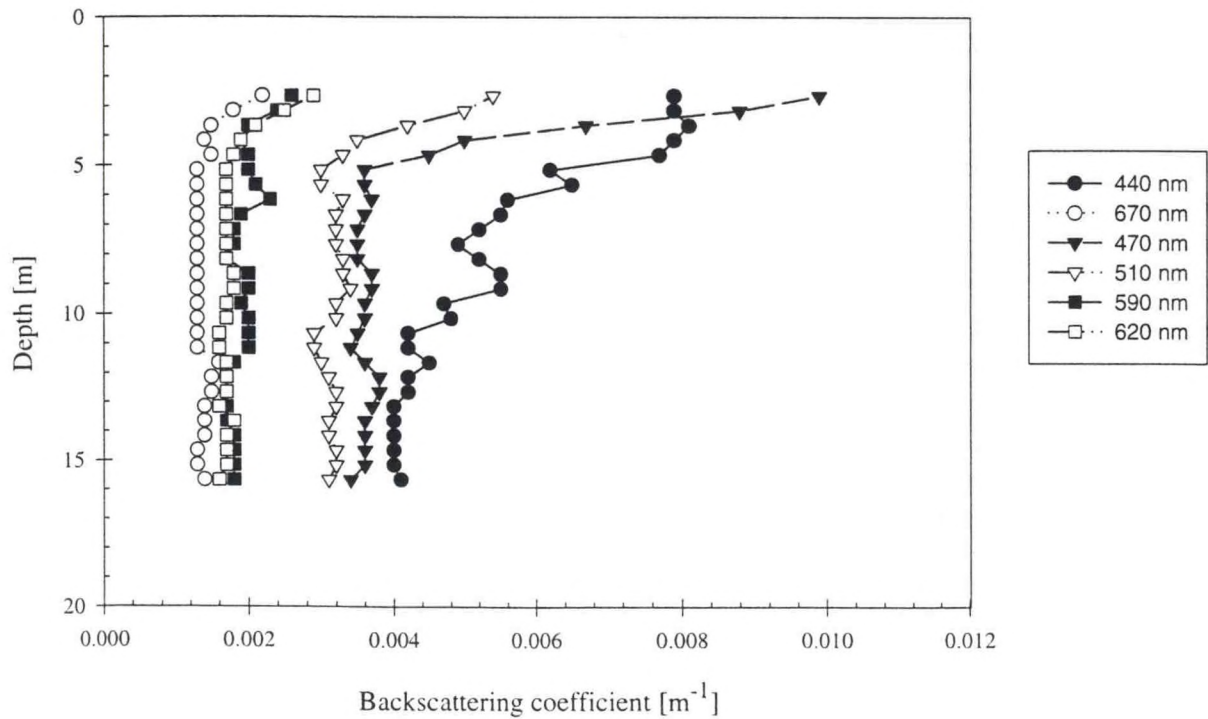

Figure E.3.a - Station 9 Downcast

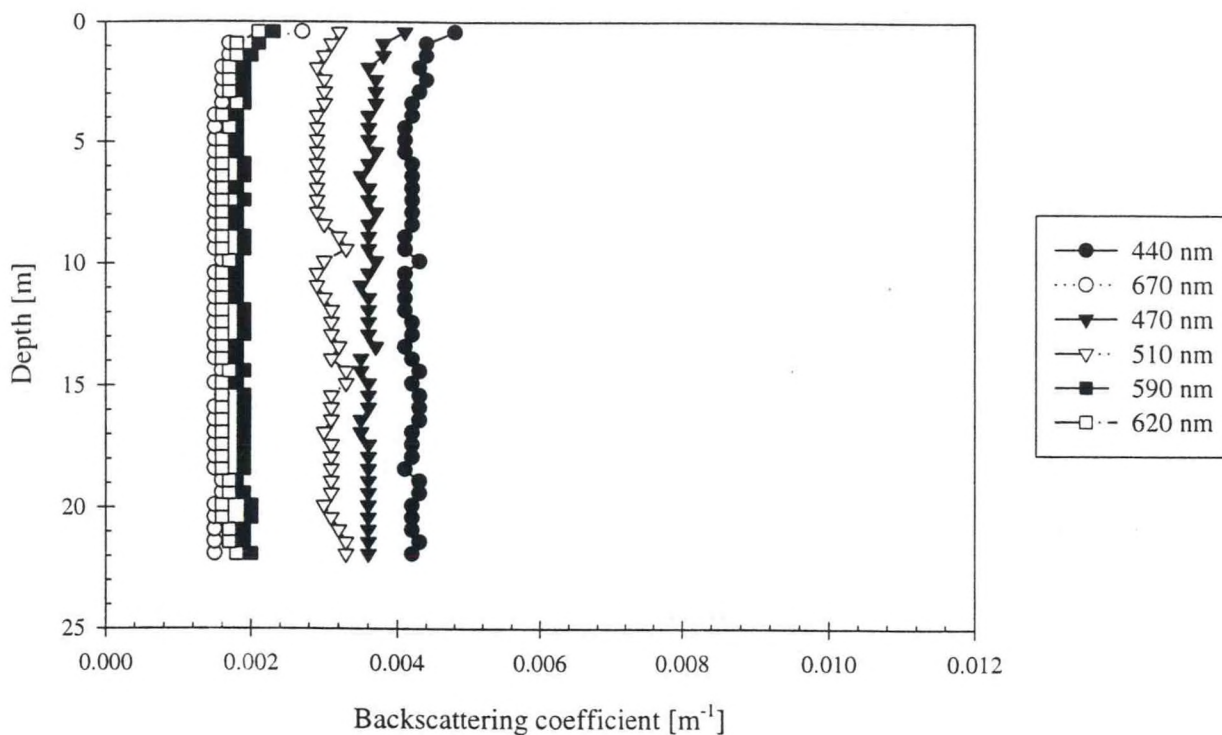

Figure E.3.b - Station 9 Upcast

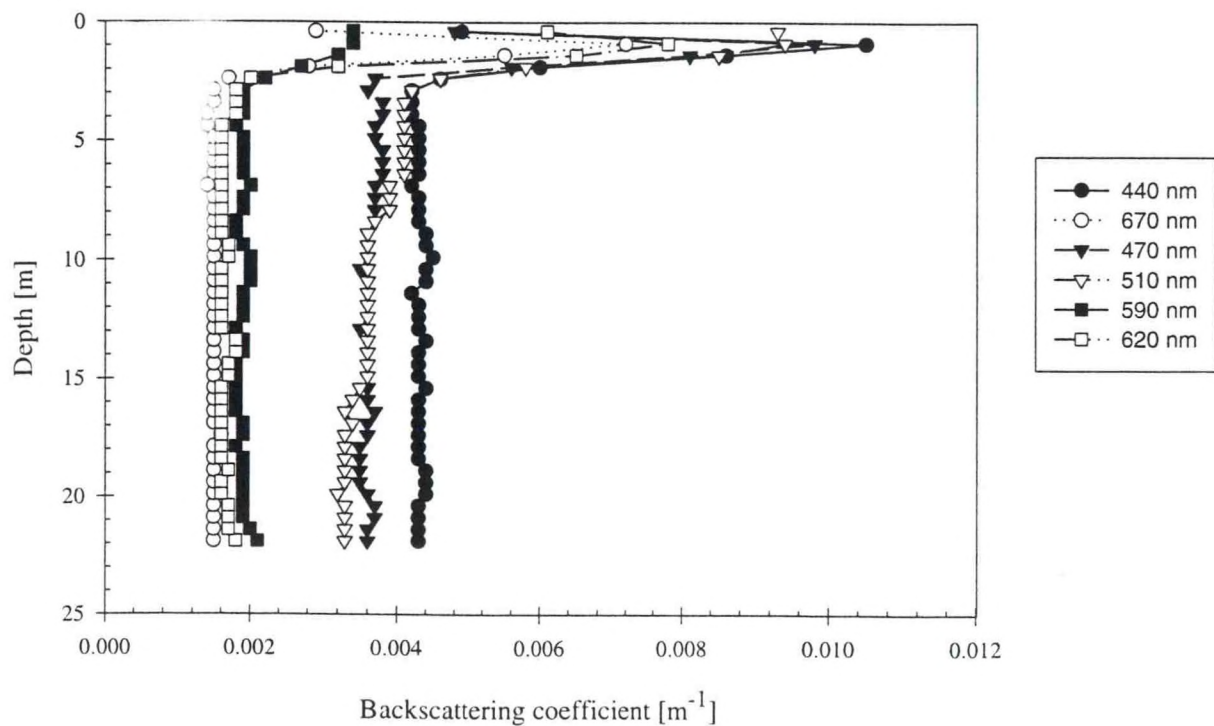

Figure E.4.a - Station 13 Downcast

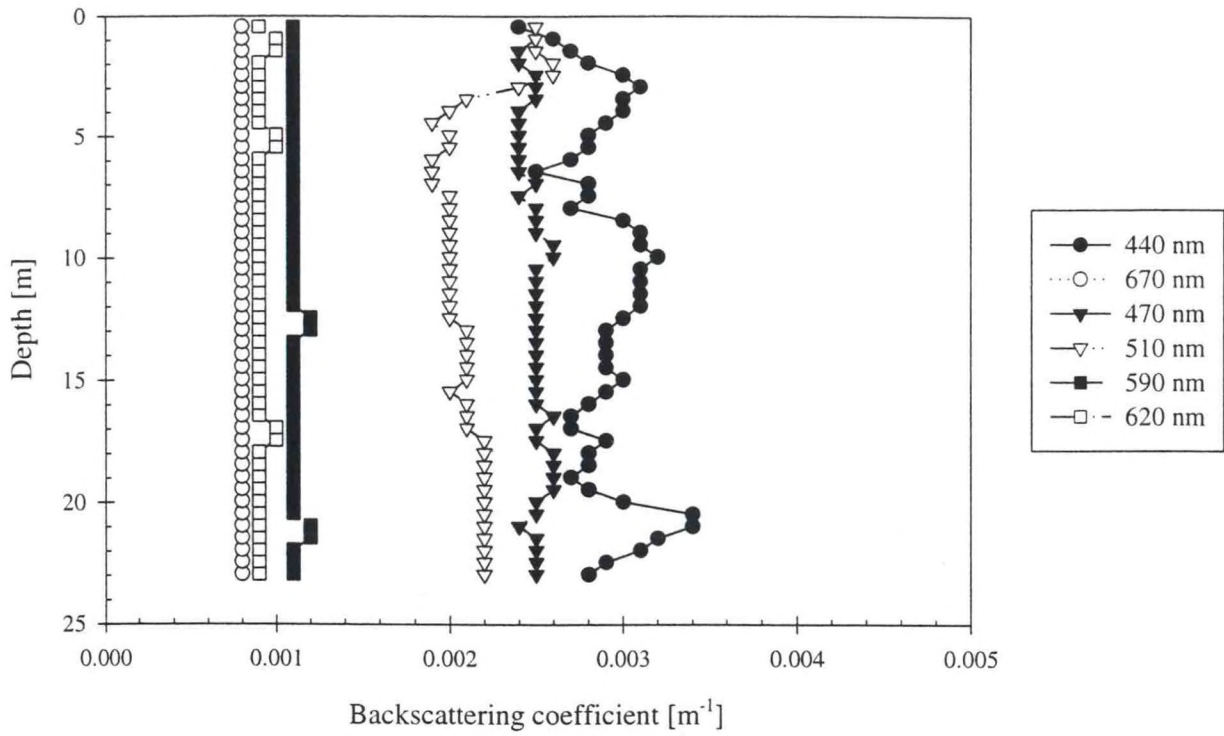

Figure E.4.b - Station 13 Upcast

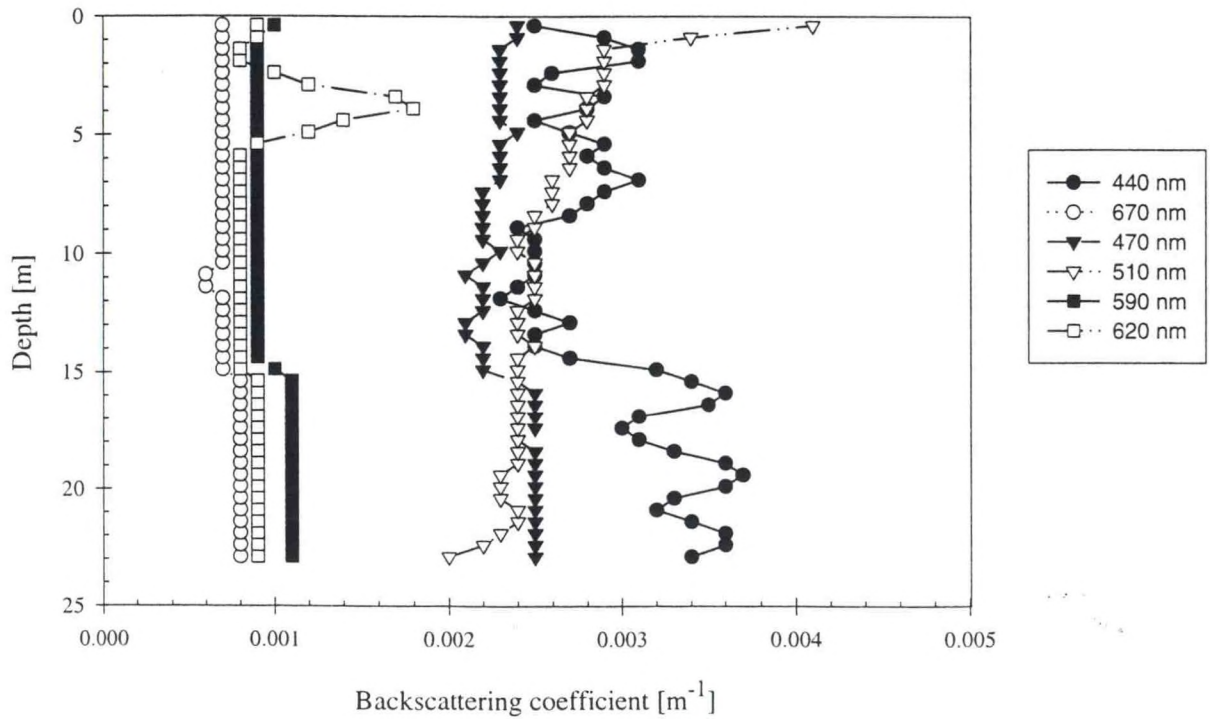

Figure E.5.a - Station 14 Downcast

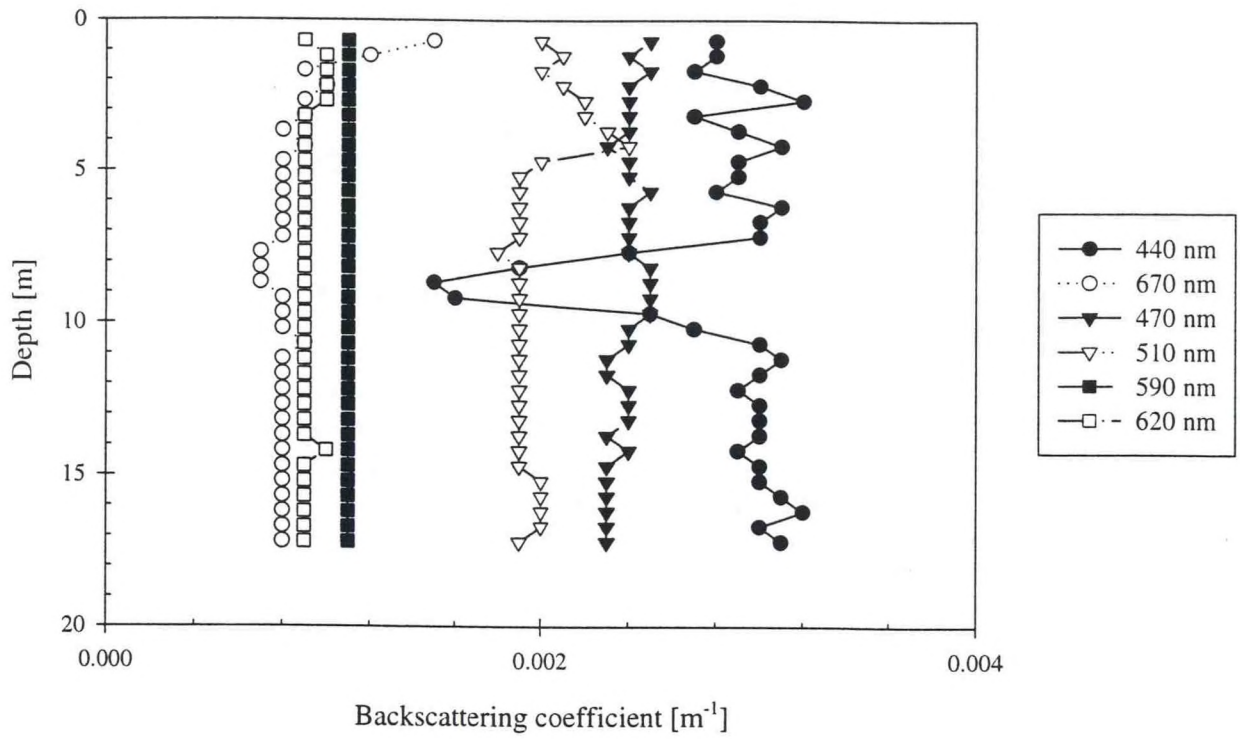

Figure E.5.b - Station 14 Upcast

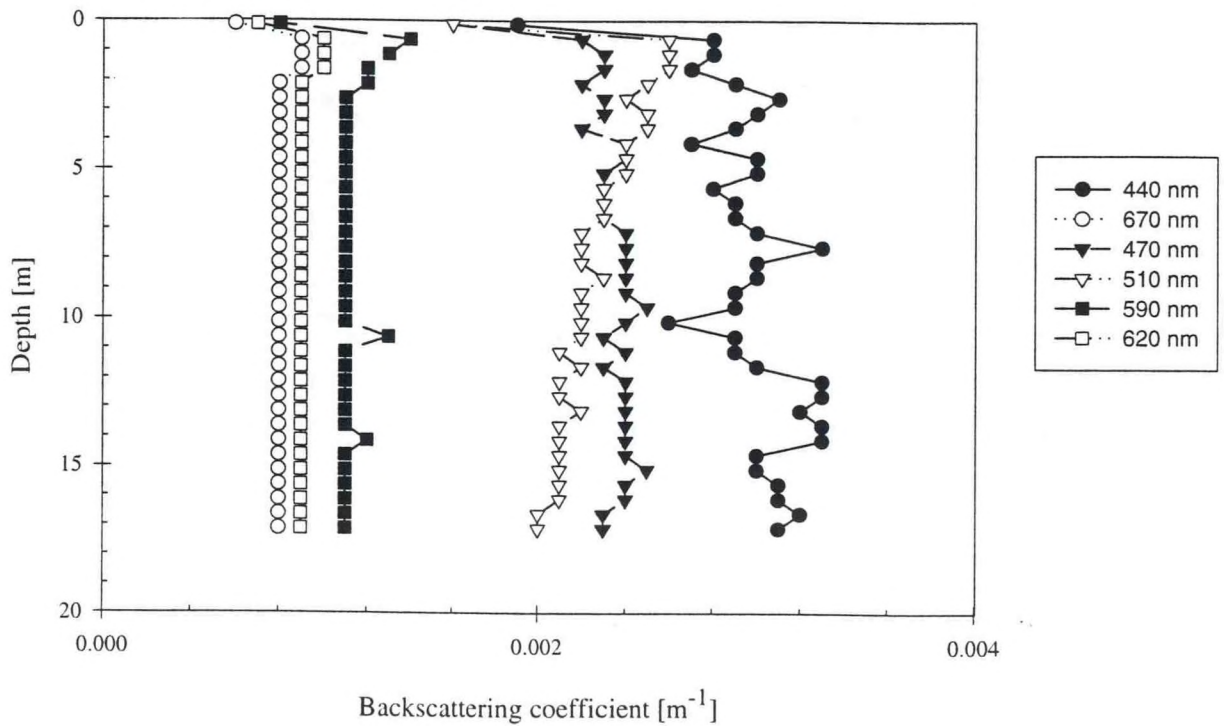

Figure E.6.a - Station 15 Downcast

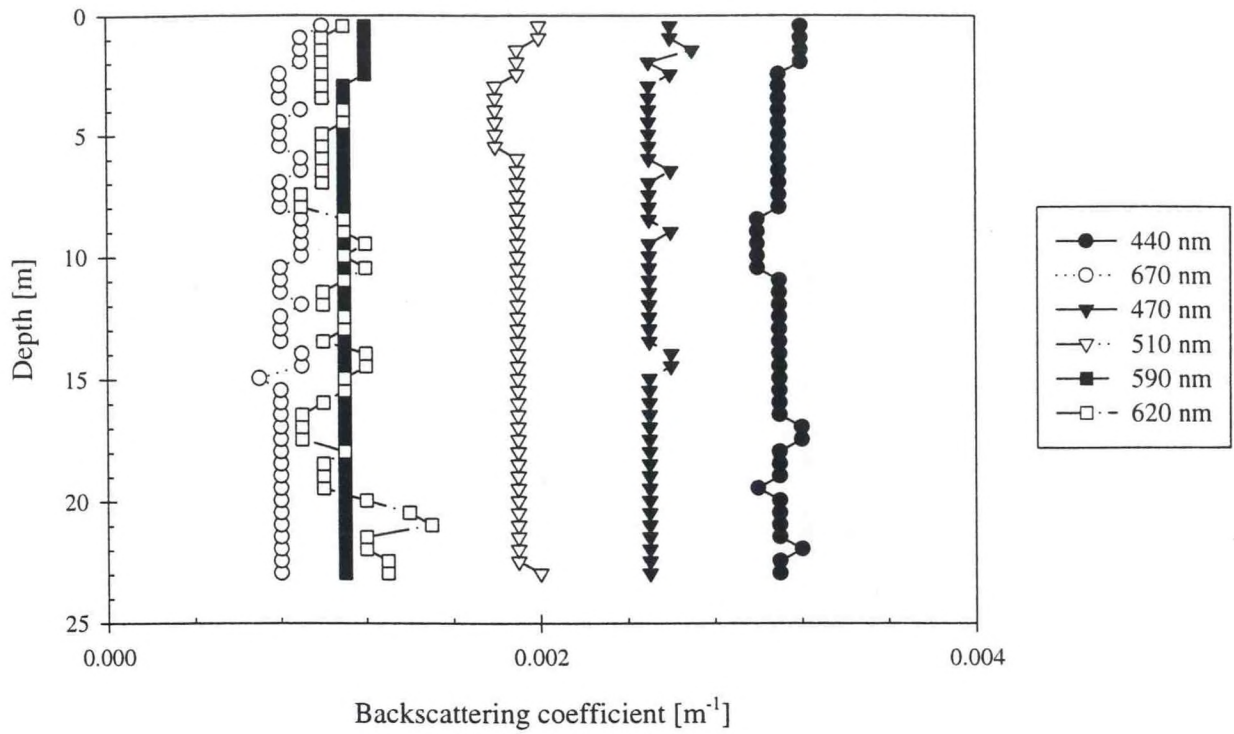

Figure E.6.b - Station 15 Upcast

