

**NATIONAL MARINE FISHERIES SERVICE
ENDANGERED SPECIES ACT
BIOLOGICAL OPINION**

Agency: Army Corps of Engineers (USACE), Norfolk District (lead)
Bureau of Ocean Energy Management

Activity Considered: Use of Sandbridge Shoals Borrow Area for Sandbridge Shoals
Hurricane Protection Project, 2012-2013
F/NER/2012/01586
GARFO-2012-00014

Conducted by: National Marine Fisheries Service
Northeast Region

SEP - 7 2012

Date Issued: _____

Approved by: _____

George H. Dany for John K. Ballard

Table of Contents

1.0	INTRODUCTION.....	4
2.0	CONSULTATION HISTORY	4
3.0	DESCRIPTION OF THE PROPOSED ACTION	5
3.1	Information on Dredges that may be used.....	6
3.2	Bed Leveling Devices.....	7
3.3	Interrelated or Interdependent Actions	8
3.4	Action Area.....	8
4.0	SPECIES THAT ARE NOT LIKELY TO BE ADVERSELY AFFECTED BY THE PROPOSED ACTION	8
4.1	Shortnose Sturgeon	8
4.2	Hawksbill sea turtle.....	9
4.3	Sperm, Blue, Right, Humpback and Fin whales	9
5.0	STATUS OF LISTED SPECIES IN THE ACTION AREA THAT MAY BE AFFECTED BY THE PROPOSED ACTION	10
5.1	Overview of Status of Sea Turtles.....	10
5.2	Northwest Atlantic DPS of loggerhead sea turtle.....	11
5.3	Status of Kemp's Ridley Sea Turtles.....	25
5.4	Status of Green Sea Turtles	29

5.5	Status of Leatherback Sea Turtles	33
5.6	Status of Atlantic sturgeon	41
5.7	Gulf of Maine DPS of Atlantic sturgeon	48
5.8	New York Bight DPS of Atlantic sturgeon	51
5.9	Chesapeake Bay DPS of Atlantic sturgeon	54
5.10	Carolina DPS of Atlantic sturgeon	55
5.11	South Atlantic DPS of Atlantic sturgeon.....	60
6.0	ENVIRONMENTAL BASELINE	65
6.1	Federal Actions that have Undergone Formal or Early Section 7 Consultation	65
6.2	State or Private Actions in the Action Area	68
6.3	Other Impacts of Human Activities in the Action Area	71
7.0	Climate Change	73
7.1	Background Information on Global climate change.....	73
7.2	Species Specific Information on Climate Change Effects.....	75
7.3	Effects of Climate Change in the Action Area	80
7.4	Effects of Climate Change in the Action Area to Atlantic sturgeon	81
7.5	Effects of Climate Change in the Action Area on Sea Turtles	82
8.0	EFFECTS OF THE ACTION.....	83
8.1	Hopper Dredge	83
8.2	Hydraulic Cutterhead Dredge	99
8.3	Dredged Material Disposal	104
8.4	Effects on Benthic Resources and Foraging.....	104
8.5	Dredge and Disposal Vessel Traffic	105
8.6	Unexploded Ordinance and Munitions of Concern	106
8.7	Bed Leveling Devices.....	108
9.0	CUMULATIVE EFFECTS	108
10.0	INTEGRATION AND SYNTHESIS OF EFFECTS.....	109
10.1	Atlantic sturgeon.....	110
10.2	Green sea turtles	122
10.3	Leatherback sea turtles	126
10.4	Kemp’s ridley sea turtles	126
10.5	Northwest Atlantic DPS of Loggerhead sea turtles.....	129
11.0	CONCLUSION	134
12.0	INCIDENTAL TAKE STATEMENT.....	134

12.1	Amount or Extent of Incidental Take	135
12.2	Reasonable and prudent measures	137
12.3	Terms and conditions.....	139
13.0	CONSERVATION RECOMMENDATIONS	142
14.0	REINITIATION OF CONSULTATION	143
15.0	LITERATURE CITED	144
	APPENDIX A	179
	APPENDIX B	180
	APPENDIX C	187
	APPENDIX D	193
	APPENDIX E.....	197
	APPENDIX F	199
	APPENDIX G	200
	APPENDIX H	202

1.0 INTRODUCTION

This constitutes the biological opinion (Opinion) of NOAA's National Marine Fisheries Service (NMFS) issued pursuant to Section 7 of the Endangered Species Act (ESA) of 1973, as amended, on the effects of the Army Corps of Engineers, Norfolk District (USACE) proposal to dredge in Sandbridge Shoal borrow area in 2012-2013 for purposes of obtaining sand to be placed on Sandbridge Beach. Because Sandbridge Shoal is located on the Outer Continental Shelf, authorization is also required from the Bureau of Ocean Energy Management (BOEM).

This Opinion is based on information provided in the Biological Assessment (BA) dated April 5, 2012, past consultations with the USACE Norfolk and Baltimore Districts and scientific papers and other sources of information as cited in this Opinion. We will keep a complete administrative record of this consultation at our Northeast Regional Office. By issuing this Opinion we withdraw the Opinion issued by us regarding the Sandbridge Beach Hurricane Protection Project on April 2, 1993, and amended on August 20, 2001.

2.0 CONSULTATION HISTORY

Consultation between USACE and NMFS on effects of dredging in the Chesapeake Bay navigation channels and borrow areas has been ongoing since the 1980s. Formal consultation for the use of the Sandbridge Shoal borrow area was initiated in May 1992. A Biological Opinion was issued by us on April 2, 1993. This Opinion was amended by letter issued August 20, 2001 to account for greater dredging quantities, project durations, and associated impacts to listed sea turtles. In 2007, USACE requested that we waive the requirement for 100% endangered species observer coverage for dredging planned for 2007. This request was due to the presence of unexploded ordinance (UXO) in the area to be dredged and the placement of screening on the dragheads. We granted that request by letter and determined that the use of UXO screening did not require reinitiation of the consultation. The 1993 Opinion, as amended in 2001, concluded that dredging in Sandbridge Shoal was not likely to jeopardize the continued existence of any species of whale or sea turtle. An Incidental Take Statement (ITS) was included with the Opinion, exempting the lethal take of six loggerhead sea turtles and one Kemp's ridley or green sea turtle for each biennial dredge event. Use of the Sandbridge Shoal borrow areas requires coordination with the Bureau of Ocean Energy Management (BOEM); the USACE was designated the lead agency for purposes of complying with ESA requirements per 50 C.F.R. 5402.07 and serves as the lead agency for ESA consultation.

On February 6, 2012, we published two final rules listing five Distinct Population Segments (DPS) of Atlantic sturgeon. The New York Bight, Chesapeake Bay, South Atlantic and Carolina DPSs are listed as endangered and the Gulf of Maine DPS is listed as threatened. Reinitiation of consultation is required if: "(a) the amount or extent of taking specified in the ITS is exceeded; (b) new information reveals effects of these actions that may affect listed species or critical habitat in a manner or to an extent not previously considered; (c) any of the identified actions are subsequently modified in a manner that causes an effect to the listed species that was not considered in the Opinion; or (d) a new species is listed or critical habitat designated that may be affected by the identified actions" (50 CFR § 402.16).

In a letter dated April 5, 2012, USACE requested reinitiation of the 1993 consultation. USACE submitted a Biological Assessment with this letter. Discussions between USACE and NMFS staff through the spring and summer of 2012 sought to clarify the extent of the proposed action, the

relationship between multiple dredge actions proposed for the Chesapeake Bay and the duration of these activities. Consultation was initiated on April 5, 2012. A draft of the Biological Opinion was provided to USACE on August 2, 2012; comments were received on August 13, 2012 and incorporated as appropriate.

3.0 DESCRIPTION OF THE PROPOSED ACTION

This Opinion considers the effects of work proposed for 2012-2013 in Sandbridge Shoals. This work will be carried out by the USACE and their contractors. Additionally, authorization from BOEM, in the form of a lease, is required for use of the Sandbridge Shoal borrow area.

The Advanced Engineering and Design Study for Beach Erosion and Hurricane Protection at Virginia Beach, Virginia, including Sandbridge Beach, was authorized by Section 1(a) of the Water Resources Development Act of 1974 (Public Law 93-251, 93'd Congress, H.R. 10203.7 March 1974). The applicable portion of the authorizing act is as follows:

"Sec. I (a) The Secretary of the Army, acting through the Chief of Engineers, is hereby authorized to undertake the Phase I Design Memorandum stage of advanced engineering and design of the following multi-purpose water resources development projects, substantially in accordance with, and subject to the conditions recommended by the Chief of Engineers in the reports here in after designated."

Middle Atlantic Coastal Area

"The project for hurricane-flood protection at Virginia Beach, Virginia: House Document Numbered 92-365, at an estimated cost of 8954,000 (1974 dollars)."

BOEM will authorize the use of sand from an OCS sand borrow area for the project under the OCS Lands Act, 43 U.S.C. §1337(k). In 1994, OCSLA was amended to allow BOEM to convey, on a noncompetitive basis, the rights to OCS sand, gravel, or shell resources for use in a program for shore protection, beach restoration, or coastal wetlands restoration undertaken by a Federal, State, or local government agency (43 U.S.C. 1337(k)(2)(A)(i)). An agreement will be negotiated between BOEM, the USACE Norfolk District, and City of Virginia Beach for the dredging and relocation of the sand.

The proposed action would involve beach nourishment at the Sandbridge oceanfront, an area approximately 5 miles long and 725 feet wide (as illustrated in Appendix A). The specific beach area covered extends from the U.S. Naval Fleet Anti-Air Warfare Training Center at Dam Neck to the north to Back Bay National Wildlife Refuge (NWR) to the south. The project dimensions include a 50-foot wide berm at an elevation of 6 feet North American Vertical Datum (NGVD) with a foreshore slope of approximately 1:20 (one vertical value to 20 horizontal) for a distance of approximately 5 miles. The designated borrow area is Sandbridge Shoal (Appendix A), located approximately 3 nautical miles from the shoreline, outside of Virginia's territorial sea. There are two selected borrow areas within Sandbridge Shoal, Area B to the north and Area A to the south; depths range from 30 to 65 feet. The area between the two borrow areas is restricted due to the presence of a buried Navy submarine communications cable. Beach quality sand would most likely be removed

by trailing suction hopper dredge with the possibility of using a hydraulic pipeline dredge (i.e. cutterhead).

The hopper dredge is a self-propelled vessel equipped with trailing suction dragheads and a hopper that collects sand. When the hopper is full, material is transported to a pump out buoy located offshore. The material would then be pumped through a pipeline, which runs along the ocean floor, and up onto the beach where bulldozers and graders will distribute the sand. There are known ordinance issues located within the Sandbridge Shoals area, UXO screening will be required for this action. This is due to training operations at the U.S. Naval Fleet Anti-Air Warfare Training Center at Dam Neck. Ordinances have been found in earlier dredging actions for this on-going project.

A hydraulic pipeline dredge uses a cutterhead to loosen or dislodge sediments to hydraulically capture the material. The slurried sediment is transported through a pipeline to the placement site. Because pipeline dredges pump directly to the placement site, they can operate continuously and can be very productive and cost efficient. Once the material is placed on the beach similar construction methods are used to distribute the material properly.

The purpose of the proposed action is to provide protection from erosion induced damages including limited protection to the beach and to residential structures from storm damage. Several alternatives were considered in the feasibility phase of the project including structural, non-structural and a no action alternative. Neither one nor a combination of the other alternatives discussed provided an acceptable solution in terms of feasibility and/or economics, environmental, and technical concerns, to the existing beach erosion and hurricane protection needs; and, thus were eliminated from further consideration as viable solutions to coastal erosion and storm problems at Sandbridge Beach.

As previously mentioned, the proposed action will utilize either a hopper style dredge or a hydraulic pipeline dredge to borrow beach quality sand from authorized sites along Sandbridge Shoals to renourish the beach at Sandbridge Beach via the placement of dredged material onto the beach. Approximately 1.5 to 2.0 million cubic yards will be placed on this section of the beach for erosion control and to provide hurricane relief as requested by the non-federal sponsor, the City of Virginia Beach. The action is planned to occur from December 1, 2012 to May 15, 2013 but could occur outside of this period.

3.1 Information on Dredges that may be used

In the past, a hopper dredge has been used at Sandbridge Shoals. However, USACE has indicated that a hydraulic cutterhead dredge may be used at Sandbridge Shoal for the dredging contemplated in this action. The type of dredge to be used will be determined during the contract review process.

3.1.1 Self-Propelled Hopper Dredges

Hopper dredges are typically self-propelled seagoing vessels. They are equipped with propulsion machinery, sediment containers (i.e., hoppers), dredge pumps, and other specialized equipment required to excavate sediments from the channel bottom. Hopper dredges have propulsion power adequate for required free-running speed and dredging against strong currents.

A hopper dredge removes material from the bottom of the channel in thin layers, usually 2-12 inches, depending on the density and cohesiveness of the dredged material (Taylor, 1990). Pumps within the hull, but sometimes mounted on the dragarm, create a region of low pressure around the dragheads; this forces water and sediment up the dragarm and into the hopper. The more closely the draghead is maintained in contact with the sediment, the more efficient the dredging (i.e., the greater the concentration of sediment pumped into the hopper). In the hopper, the slurry mixture of sediment and water is managed to settle out the dredged material solids and overflow the supernatant water. When a full load is achieved, the vessel suspends dredging, the dragarms are heaved aboard, and the dredge travels to the placement site where dredged material is disposed of.

3.1.2 Hydraulic Cutterhead Pipeline Dredges

The cutterhead dredge is essentially a barge hull with a moveable rotating cutter apparatus surrounding the intake of a suction pipe (Taylor, 1990). By combining the mechanical cutting action with the hydraulic suction, the hydraulic cutterhead has the capability of efficiently dredging a wide range of material, including clay, silt, sand, and gravel.

The largest hydraulic cutterhead dredges have 30 to 42 inch diameter pumps with 15,000 to 20,000 horsepower. The dredge used for this project is expected to have a pump and pipeline with approximately 30" diameter. These dredges are capable of pumping certain types of material through as much as 5-6 miles of pipeline, though up to 3 miles is more typical. The cutterhead pipeline plant employs spuds and anchors in a manner similar to floating mechanical dredges.

3.2 Bed Leveling Devices

USACE has indicated that in certain circumstances, a dredge contractor may employ a bed-leveler device to smooth the channel bottom or to reduce the heights of disposal mounds created during hydraulic placement operations. The USACE has reported that they are not aware of any instances where bed-leveling has been utilized in Sandbridge Shoals. However, bed-leveling may be a preferred alternative during certain phases of the dredging operations (i.e. clean-up phase) and it is possible that a bed leveler will be used during this dredge cycle.

Bed leveling techniques have been documented as far back as 1565 (USACE, 2006). However, the use of bed-levelers in U.S. waters is not well documented. The devices are typically used during final clean-up operations when localized mounds or ridges exist shallower than required dredging depths. Passage of a draghead can create ridges up to two feet high and can require multiple passes to reduce the height during clean-up operations. Often these areas cannot be efficiently or economically dredged to specified depths and make it difficult to maintain hard contact between the draghead and channel bottom. Bed-leveler devices may consist of a large customized plow or a box beam suspended from a work-barge that can be pushed or towed by a tug. The bed-leveler may be towed by a short or long towing line depending on the sea-state. Bed-leveler size and geometry can vary but are typically thirty and fifty feet in width and may weigh from twenty-five to fifty tons. Bed-levelers are generally towed at speeds ranging from 1-2 knots. Bed-leveler operation can be affected by sea state conditions and generally require longer towing line in rougher waters.

The USACE-ERDC has performed an engineering evaluation on various configurations of bed-leveler prototypes to determine their performance aspects for production rates (i.e. ability to remove target material), ability to deflect model turtles, and bed-leveler construction and operation in the

field. Model studies were performed at Texas A&M. The study tested conceptual designs using a conventional straight square tube box-beam, a 90-degree raked plow (i.e. inclined), a 90-degree square tube box beam plow, a 130-degree box square tube box beam plow. Model study results indicated that the straight square tube box beam design provided the highest production rate moving sediment in the direction of the bed leveler device but provided the least turtle shedding capability. The 90-degree raked (inclined) plow produced an increased vertical downward force on the towing cables resulting in some operational difficulty. In general, the increase in the sweep angle increased the side-spilling or side-casting of sediment which also accounted for the designs ability to shed model turtles from in front of the bed-leveler device. The 130-degree box beam plow likely provides the optimal mix of production, turtle shedding capability, and operational deployment. The conceptual bed-leveling designs tested in the model study are presented in Appendix F of USACE's BA (Appendix B of this Opinion).

3.3 Interrelated or Interdependent Actions

Interrelated actions are those that are part of a larger action and depend upon the larger action for their justification. Interdependent actions are those that have no independent utility apart from the action under consideration (50 CFR § 402.02; see also 1998 FWS-NMFS Joint Consultation Handbook, pp. 4-26 to 4-28). We have not identified any interrelated or interdependent actions.

3.4 Action Area

The action area is defined in 50 CFR § 402.02 as "all areas to be affected directly or indirectly by the Federal action and not merely the immediate area involved in the action." The action area for this consultation includes the area affected by dredging and disposal activities as well as the area transited by dredges and dredged material disposal vessels. The action area, therefore, includes the entirety of the navigation channels, borrow areas and disposal areas noted above. The action area will also encompass the underwater area where dredging will result in increased suspended sediment. The size of the sediment plume will vary depending on the type of dredge used and is detailed below.

4.0 SPECIES THAT ARE NOT LIKELY TO BE ADVERSELY AFFECTED BY THE PROPOSED ACTION

4.1 Shortnose Sturgeon

Shortnose sturgeon are benthic fish that occur in large coastal rivers of eastern North America. They range from as far south as the St. Johns River, Florida (possibly extirpated from this system) to as far north as the Saint John River in New Brunswick, Canada. Shortnose sturgeon occur in 19 rivers along the U.S. Atlantic coast. Shortnose sturgeon historically occurred in the Chesapeake Bay, but prior to 1996, the best available information suggested that the species was either extirpated from the area or present in extremely low numbers. Before 1996, there were only 15 published historic records of shortnose sturgeon in the Chesapeake Bay, and most of these were based on personal observations from the upper Chesapeake Bay during the 1970s and 1980s (Dadswell et al. 1984). From February through November 1997, a Fish and Wildlife Service reward program was in effect for Atlantic sturgeon in Virginia's major tributaries (James, York, and Rappahannock Rivers). A sturgeon captured from the Rappahannock River in May 1997 was confirmed as a shortnose sturgeon (Spells 1998). This capture represents the only recent capture of a shortnose sturgeon in Virginia. On October 22, 2003, an endangered species observer initially reported the capture of one shortnose sturgeon in a sea turtle relocation trawling operation in

Thimble Shoals Channel. Several Atlantic sturgeon were captured during the relocation trawl and due to the difficulty in distinguishing these species, the fish was initially reported as a shortnose sturgeon. The captured fish was reported as 123 cm fork length (FL), which is close to the maximum length of shortnose sturgeon in northern river systems reported in the literature (130 cm FL) and far greater than the maximum length of shortnose sturgeon in southern river systems (97 cm FL). Further analysis resulted in the observer correcting the report and stating that the fish was actually an Atlantic sturgeon.

Despite numerous studies that have occurred to document the presence of Atlantic sturgeon in Virginia waters, only one shortnose sturgeon has been captured. Because we anticipate that shortnose sturgeon would have been captured in sampling gear if present, and that these captures would be reported to NMFS, we believe this lack of captures is indicative of the rarity of shortnose sturgeon in Virginia waters of the Chesapeake Bay. We do not anticipate that shortnose sturgeon would be present in the action area and therefore, any effects to shortnose sturgeon are extremely unlikely to occur. The lack of any interactions with shortnose sturgeon during dredging or relocation trawling associated with any of the channels or borrow areas in the lower Chesapeake Bay to date, supports this determination. Because any effects to shortnose sturgeon are extremely unlikely to occur, all effects to shortnose sturgeon are discountable. As such, we have determined that the proposed action is not likely to adversely affect this species and it is not considered further in this Opinion.

4.2 Hawksbill sea turtle

The hawksbill sea turtle is listed as endangered. This species is uncommon in the waters of the continental U.S. Hawksbills prefer coral reef habitats, such as those found in the Caribbean and Central America. Mona Island (Puerto Rico) and Buck Island (St. Croix, U.S. Virgin Islands) contain especially important foraging and nesting habitat for hawksbills. Within the continental U.S., nesting is restricted to the southeast coast of Florida and the Florida Keys, but nesting is rare in these areas. Hawksbills have been recorded from all the Gulf States and along the east coast of the U.S. as far north as Massachusetts, but sightings north of Florida are rare. Many of these strandings in the North Atlantic were observed after hurricanes or offshore storms. Aside from Florida, Texas is the only other U.S. state where hawksbills are sighted with any regularity.

Only two hawksbill sea turtles have been documented in Virginia waters since 1979 (Mansfield 2006) and no hawksbill sea turtles have ever been documented in the Chesapeake Bay. The occurrence of Hawksbill sea turtles in the Chesapeake Bay would be an extremely rare occurrence. Because Hawksbill sea turtles are so unlikely to occur in the action area, impacts to this species are considered extremely unlikely. The lack of any interactions with hawksbills during dredging or relocation trawling associated with any of the channels or borrow areas in the Chesapeake Bay to date, supports this determination. Because any effects to hawksbills are extremely unlikely to occur, all effects to hawksbill sea turtles are discountable. As such, we have determined that the proposed action is not likely to adversely affect this species and it is not considered further in this Opinion.

4.3 Sperm, Blue, Right, Humpback and Fin whales

Sperm whales and blue whales are listed as endangered. During surveys for the Cetacean and Turtle Assessment Program (CeTAP), sperm whales were observed along the shelf edge, centered around the 1,000 m depth contour but extending seaward out to the 2,000 m depth contour (CeTAP

1982). Although blue whales are occasionally seen in U.S. waters, they are more commonly found in Canadian waters and are rare in continental shelf waters of the eastern U.S. (Waring *et al.* 2000). Given the predominantly offshore distribution of these two cetacean species, both are highly unlikely to occur in the action area or to be affected by the actions considered in this Opinion.

The Chesapeake Bay is not a high use area for whales. Transient individual right, humpback and fin whales may occasionally be present in the lower Bay for brief periods during annual migrations or during the summer months, but no whales are known to be resident in this area and even transient whales are considered rare in the action area. Because any effects to whales are extremely unlikely to occur, all effects to whales are discountable. As such, we have determined that the proposed action is not likely to adversely affect right, humpback or fin whales. These species will not be considered further in this Opinion.

5.0 STATUS OF LISTED SPECIES IN THE ACTION AREA THAT MAY BE AFFECTED BY THE PROPOSED ACTION

Several species listed under NMFS’ jurisdiction occur in the action area for this consultation. NMFS has determined that the action being considered in this biological opinion may affect the following endangered or threatened species under NMFS’ jurisdiction:

Sea Turtles

Northwest Atlantic DPS of Loggerhead sea turtle (<i>Caretta caretta</i>)	Threatened
Leatherback sea turtle (<i>Dermochelys coriacea</i>)	Endangered
Kemp’s ridley sea turtle (<i>Lepidochelys kempi</i>)	Endangered
Green sea turtle (<i>Chelonia mydas</i>)	Endangered/Threatened ¹

Fish

Gulf of Maine DPS of Atlantic sturgeon (<i>Acipenser oxyrinchus oxyrinchus</i>)	Threatened
New York Bight DPS of Atlantic sturgeon	Endangered
Chesapeake Bay DPS of Atlantic sturgeon	Endangered
South Atlantic DPS of Atlantic sturgeon	Endangered
Carolina DPS of Atlantic sturgeon	Endangered

This section will focus on the status of the various species within the action area, summarizing information necessary to establish the environmental baseline and to assess the effects of the proposed action.

5.1 Overview of Status of Sea Turtles

With the exception of loggerheads, sea turtles are listed under the ESA at the species level rather than as subspecies or distinct population segments (DPS). Therefore, information on the range-wide status of leatherback, Kemp’s ridley and green sea turtles is included to provide the status of each species overall. Information on the status of loggerheads will only be presented for the DPS affected by this action. Additional background information on the range-wide status of these

¹ Pursuant to NMFS regulations at 50 CFR 223.205, the prohibitions of Section 9 of the Endangered Species Act apply to all green turtles, whether endangered or threatened.

species can be found in a number of published documents, including sea turtle status reviews and biological reports (NMFS and USFWS 1995; Hirth 1997; Marine Turtle Expert Working Group [TEWG] 1998, 2000, 2007, 2009; NMFS and USFWS 2007a, 2007b, 2007c, 2007d; Conant *et al.* 2009), and recovery plans for the loggerhead sea turtle (NMFS and USFWS 2008), Kemp's ridley sea turtle (NMFS *et al.* 2011), leatherback sea turtle (NMFS and USFWS 1992, 1998a), Kemp's ridley sea turtle (NMFS *et al.* 2011) and green sea turtle (NMFS and USFWS 1991, 1998b).

2010 BP Deepwater Horizon Oil Spill

The April 20, 2010, explosion of the Deepwater Horizon oil rig affected sea turtles in the Gulf of Mexico. There is an on-going assessment of the long-term effects of the spill on Gulf of Mexico marine life, including sea turtle populations. Following the spill, juvenile Kemp's ridley, green, and loggerhead sea turtles were found in *Sargassum* algae mats in the convergence zones, where currents meet and oil collected. Sea turtles found in these areas were often coated in oil and/or had ingested oil. Approximately 536 live adult and juvenile sea turtles were recovered from the Gulf and brought into rehabilitation centers; of these, 456 were visibly oiled (these and the following numbers were obtained from <http://www.nmfs.noaa.gov/pr/health/oilspill/>). To date, 469 of the live recovered sea turtles have been successfully returned to the wild, 25 died during rehabilitation, and 42 are still in care but are expected to be returned to the wild eventually. During the clean-up period, 613 dead sea turtles were recovered in coastal waters or on beaches in Mississippi, Alabama, Louisiana, and the Florida Panhandle. As of February 2011, 478 of these dead turtles had been examined. Many of the examined sea turtles showed indications that they had died as a result of interactions with trawl gear, most likely used in the shrimp fishery, and not as a result of exposure to or ingestion of oil.

During the spring and summer of 2010, nearly 300 sea turtle nests were relocated from the northern Gulf to the east coast of Florida with the goal of preventing hatchlings from entering the oiled waters of the northern Gulf. From these relocated nests, 14,676 sea turtles, including 14,235 loggerheads, 125 Kemp's ridleys, and 316 greens, were ultimately released from Florida beaches.

A thorough assessment of the long-term effects of the spill on sea turtles has not yet been completed. The spill resulted in the direct mortality of many sea turtles and may have had sublethal effects or caused environmental damage that will impact sea turtles into the future. The population level effects of the spill and associated response activity are likely to remain unknown for some period into the future.

5.2 Northwest Atlantic DPS of loggerhead sea turtle

The loggerhead is the most abundant species of sea turtle in U.S. waters. Loggerhead sea turtles are found in temperate and subtropical waters and occupy a range of habitats including offshore waters, continental shelves, bays, estuaries, and lagoons. They are also exposed to a variety of natural and anthropogenic threats in the terrestrial and marine environment.

Listing History

Loggerhead sea turtles were listed as threatened throughout their global range on July 28, 1978. Since that time, several status reviews have been conducted to review the status of the species and make recommendations regarding its ESA listing status. Based on a 2007 5-year status review of the species, which discussed a variety of threats to loggerheads including climate change, NMFS

and FWS determined that loggerhead sea turtles should not be delisted or reclassified as endangered. However, we also determined that an analysis and review of the species should be conducted in the future to determine whether DPSs should be identified for the loggerhead (NMFS and USFWS 2007a). Genetic differences exist between loggerhead sea turtles that nest and forage in the different ocean basins (Bowen 2003; Bowen and Karl 2007). Differences in the maternally inherited mitochondrial DNA also exist between loggerhead nesting groups that occur within the same ocean basin (TEWG 2000; Pearce 2001; Bowen 2003; Bowen *et al.* 2005; Shamblin 2007; TEWG 2009; NMFS and USFWS 2008). Site fidelity of females to one or more nesting beaches in an area is believed to account for these genetic differences (TEWG 2000; Bowen 2003).

In part to evaluate those genetic differences, in 2008, NMFS and FWS established a Loggerhead Biological Review Team (BRT) to assess the global loggerhead population structure to determine whether DPSs exist and, if so, the status of each DPS. The BRT evaluated genetic data, tagging and telemetry data, demographic information, oceanographic features, and geographic barriers to determine whether population segments exist. The BRT report was completed in August 2009 (Conant *et al.* 2009). In this report, the BRT identified the following nine DPSs as being discrete from other conspecific population segments and significant to the species: (1) North Pacific Ocean, (2) South Pacific Ocean, (3) North Indian Ocean, (4) Southeast Indo-Pacific Ocean, (5) Southwest Indian Ocean, (6) Northwest Atlantic Ocean, (7) Northeast Atlantic Ocean, (8) Mediterranean Sea, and (9) South Atlantic Ocean.

The BRT concluded that although some DPSs are indicating increasing trends at nesting beaches (Southwest Indian Ocean and South Atlantic Ocean), available information about anthropogenic threats to juveniles and adults in neritic and oceanic environments indicate possible unsustainable additional mortalities. According to an analysis using expert opinion in a matrix model framework, the BRT report stated that all loggerhead DPSs have the potential to decline in the foreseeable future. Based on the threat matrix analysis, the potential for future decline was reported as greatest for the North Indian Ocean, Northwest Atlantic Ocean, Northeast Atlantic Ocean, Mediterranean Sea, and South Atlantic Ocean DPSs (Conant *et al.* 2009). The BRT concluded that the North Pacific Ocean, South Pacific Ocean, North Indian Ocean, Southeast Indo-Pacific Ocean, Northwest Atlantic Ocean, Northeast Atlantic Ocean, and Mediterranean Sea DPSs were at risk of extinction. The BRT concluded that although the Southwest Indian Ocean and South Atlantic Ocean DPSs were likely not currently at immediate risk of extinction, the extinction risk was likely to increase in the foreseeable future.

On March 16, 2010, NMFS and USFWS published a proposed rule (75 FR 12598) to divide the worldwide population of loggerhead sea turtles into nine DPSs, as described in the 2009 Status Review. Two of the DPSs were proposed to be listed as threatened and seven of the DPSs, including the Northwest Atlantic Ocean DPS, were proposed to be listed as endangered. NMFS and the USFWS accepted comments on the proposed rule through September 13, 2010 (75 FR 30769, June 2, 2010). On March 22, 2011 (76 FR 15932), NMFS and USFWS extended the date by which a final determination on the listing action will be made to no later than September 16, 2011. This action was taken to address the interpretation of the existing data on status and trends and its relevance to the assessment of risk of extinction for the Northwest Atlantic Ocean DPS, as well as the magnitude and immediacy of the fisheries bycatch threat and measures to reduce this threat. New information or analyses to help clarify these issues were requested by April 11, 2011.

On September 22, 2011, NMFS and USFWS issued a final rule (76 FR 58868), determining that the loggerhead sea turtle is composed of nine DPSs (as defined in Conant *et al.*, 2009) that constitute species that may be listed as threatened or endangered under the ESA. Five DPSs were listed as endangered (North Pacific Ocean, South Pacific Ocean, North Indian Ocean, Northeast Atlantic Ocean, and Mediterranean Sea), and four DPSs were listed as threatened (Northwest Atlantic Ocean, South Atlantic Ocean, Southeast Indo-Pacific Ocean, and Southwest Indian Ocean). Note that the Northwest Atlantic Ocean (NWA) DPS and the Southeast Indo-Pacific Ocean DPS were originally proposed as endangered. The NWA DPS was determined to be threatened based on review of nesting data available after the proposed rule was published, information provided in public comments on the proposed rule, and further discussions within the agencies. The two primary factors considered were population abundance and population trend. NMFS and USFWS found that an endangered status for the NWA DPS was not warranted given the large size of the nesting population, the overall nesting population remains widespread, the trend for the nesting population appears to be stabilizing, and substantial conservation efforts are underway to address threats. This final listing rule became effective on October 24, 2011.

The September 2011 final rule also noted that critical habitat for the two DPSs occurring within the U.S. (NWA DPS and North Pacific DPS) will be designated in a future rulemaking. Information from the public related to the identification of critical habitat, essential physical or biological features for this species, and other relevant impacts of a critical habitat designation was solicited. Currently, no critical habitat is designated for any DPS of loggerhead sea turtles, and therefore, no critical habitat for any DPS occurs in the action area.

Presence of Loggerhead Sea Turtles in the Action Area

The effects of this proposed action are only experienced within the Atlantic Ocean. NMFS has considered the available information on the distribution of the 9 DPSs to determine the origin of any loggerhead sea turtles that may occur in the action area. As noted in Conant *et al.* (2009), the range of the four DPSs occurring in the Atlantic Ocean are as follows: NWA DPS – north of the equator, south of 60° N latitude, and west of 40° W longitude; Northeast Atlantic Ocean (NEA) DPS – north of the equator, south of 60° N latitude, east of 40° W longitude, and west of 5° 36' W longitude; South Atlantic DPS – south of the equator, north of 60° S latitude, west of 20° E longitude, and east of 60° W longitude; Mediterranean DPS – the Mediterranean Sea east of 5° 36' W longitude. These boundaries were determined based on oceanographic features, loggerhead sightings, thermal tolerance, fishery bycatch data, and information on loggerhead distribution from satellite telemetry and flipper tagging studies. While adults are highly structured with no overlap, there may be some degree of overlap by juveniles of the NWA, NEA, and Mediterranean DPSs on oceanic foraging grounds (Laurent *et al.* 1993, 1998; Bolten *et al.* 1998; LaCasella *et al.* 2005; Carreras *et al.* 2006, Monzón-Argüello *et al.* 2006; Revelles *et al.* 2007). Previous literature (Bowen *et al.* 2004) has suggested that there is the potential, albeit small, for some juveniles from the Mediterranean DPS to be present in U.S. Atlantic coastal foraging grounds. These conclusions must be interpreted with caution however, as they may reflect a shared common haplotype and lack of representative sampling at Eastern Atlantic rookeries rather than an actual presence of Mediterranean DPS turtles in US Atlantic coastal waters. A re-analysis of the data by the Atlantic loggerhead Turtle Expert Working Group has found that that it is unlikely that U.S. fishing fleets are interacting with either the Northeast Atlantic loggerhead DPS or the Mediterranean loggerhead DPS (Peter Dutton, NMFS,

Marine Turtle Genetics Program, Program Leader, personal communication, September 10, 2011). Given that the action area is a subset of the area fished by US fleets, it is reasonable to assume that based on this new analysis, no individuals from the Mediterranean DPS or Northeast Atlantic DPS would be present in the action area. Sea turtles of the South Atlantic DPS do not inhabit the action area of this consultation (Conant *et al.* 2009). As such, the remainder of this consultation will only focus on the NWA DPS, listed as threatened.

Distribution and Life History

Ehrhart *et al.* (2003) provided a summary of the literature identifying known nesting habitats and foraging areas for loggerheads within the Atlantic Ocean. Detailed information is also provided in the 5-year status review for loggerheads (NMFS and USFWS 2007a), the TEWG report (2009), and the final revised recovery plan for loggerheads in the Northwest Atlantic Ocean (NMFS and USFWS 2008), which is a second revision to the original recovery plan that was approved in 1984 and subsequently revised in 1991.

In the western Atlantic, waters as far north as 41° N to 42° N latitude are used for foraging by juveniles, as well as adults (Shoop 1987; Shoop and Kenney 1992; Ehrhart *et al.* 2003; Mitchell *et al.* 2003). In U.S. Atlantic waters, loggerheads commonly occur throughout the inner continental shelf from Florida to Cape Cod, Massachusetts and in the Gulf of Mexico from Florida to Texas, although their presence varies with the seasons due to changes in water temperature (Shoop and Kenney 1992; Epperly *et al.* 1995a, 1995b; Braun and Epperly 1996; Braun-McNeill *et al.* 2008; Mitchell *et al.* 2003). Loggerheads have been observed in waters with surface temperatures of 7°C to 30°C, but water temperatures $\geq 11^\circ\text{C}$ are most favorable (Shoop and Kenney 1992; Epperly *et al.* 1995b). The presence of loggerhead sea turtles in U.S. Atlantic waters is also influenced by water depth. Aerial surveys of continental shelf waters north of Cape Hatteras, North Carolina indicated that loggerhead sea turtles were most commonly sighted in waters with bottom depths ranging from 22 m to 49 m deep (Shoop and Kenney 1992). However, more recent survey and satellite tracking data support that they occur in waters from the beach to beyond the continental shelf (Mitchell *et al.* 2003; Braun-McNeill and Epperly 2004; Mansfield 2006; Blumenthal *et al.* 2006; Hawkes *et al.* 2006; McClellan and Read 2007; Mansfield *et al.* 2009).

Loggerhead sea turtles occur year round in ocean waters off North Carolina, South Carolina, Georgia, and Florida. In these areas of the South Atlantic Bight, water temperature is influenced by the proximity of the Gulf Stream. As coastal water temperatures warm in the spring, loggerheads begin to migrate to inshore waters of the Southeast United States (*e.g.*, Pamlico and Core Sounds) and also move up the U.S. Atlantic coast (Epperly *et al.* 1995a, 1995b, 1995c; Braun-McNeill and Epperly 2004), occurring in Virginia foraging areas as early as April/May and on the most northern foraging grounds in the Gulf of Maine in June (Shoop and Kenney 1992). The trend is reversed in the fall as water temperatures cool. The large majority leave the Gulf of Maine by mid-September but some turtles may remain in Mid-Atlantic and Northeast areas until late fall. By December, loggerheads have migrated from inshore and more northern coastal waters to waters offshore of North Carolina, particularly off of Cape Hatteras, and waters further south where the influence of the Gulf Stream provides temperatures favorable to sea turtles (Shoop and Kenney 1992; Epperly *et al.* 1995b).

Recent studies have established that the loggerhead's life history is more complex than previously

believed. Rather than making discrete developmental shifts from oceanic to neritic environments, research is showing that both adults and (presumed) neritic stage juveniles continue to use the oceanic environment and will move back and forth between the two habitats (Witzell 2002; Blumenthal *et al.* 2006; Hawkes *et al.* 2006; McClellan and Read 2007; Mansfield *et al.* 2009). One of the studies tracked the movements of adult post-nesting females and found that differences in habitat use were related to body size with larger adults staying in coastal waters and smaller adults traveling to oceanic waters (Hawkes *et al.* 2006). A tracking study of large juveniles found that the habitat preferences of this life stage were also diverse with some remaining in neritic waters and others moving off into oceanic waters (McClellan and Read 2007). However, unlike the Hawkes *et al.* (2006) study, there was no significant difference in the body size of turtles that remained in neritic waters versus oceanic waters (McClellan and Read 2007).

Pelagic and benthic juveniles are omnivorous and forage on crabs, mollusks, jellyfish, and vegetation at or near the surface (Dodd 1988; NMFS and USFWS 2008). Sub-adult and adult loggerheads are primarily coastal dwelling and typically prey on benthic invertebrates such as mollusks and decapod crustaceans in hard bottom habitats (NMFS and USFWS 2008).

As presented below, Table 3 from the 2008 loggerhead recovery plan (Table 1 in this Opinion) highlights the key life history parameters for loggerheads nesting in the United States.

Table 3. Typical values of life history parameters for loggerheads nesting in the U.S.

Life History Parameter	Data
Clutch size	100-126 eggs ¹
Egg incubation duration (varies depending on time of year and latitude)	42-75 days ^{2,3}
Pivotal temperature (incubation temperature that produces an equal number of males and females)	29.0°C ⁵
Nest productivity (emerged hatchlings/total eggs) x 100 (varies depending on site specific factors)	45-70% ^{2,6}
Clutch frequency (number of nests/female/season)	3-5.5 nests ⁷
Interesting interval (number of days between successive nests within a season)	12-15 days ⁸
Juvenile (<87 cm CCL) sex ratio	65-70% female ⁴
Remigration interval (number of years between successive nesting migrations)	2.5-3.7 years ⁹
Nesting season	late April-early September
Hatching season	late June-early November
Age at sexual maturity	32-35 years ¹⁰
Life span	>57 years ¹¹

¹ Dodd 1988.

² Dodd and Mackinnon (1999, 2000, 2001, 2002, 2003, 2004).

³ Blair Witherington, FFWCC, personal communication, 2006 (information based on nests monitored throughout Florida beaches in 2005, n=865).

⁴ National Marine Fisheries Service (2001); Allen Foley, FFWCC, personal communication, 2005.

⁵ Mrosovsky (1988).

⁶ Blair Witherington, FFWCC, personal communication, 2006 (information based on nests monitored throughout Florida beaches in 2005, n=1,680).

⁷ Murphy and Hopkins (1984); Frazer and Richardson (1985); Ehrhart, unpublished data; Hawkes *et al.* 2005; Scott 2006; Tony Tucker, Mote Marine Laboratory, personal communication, 2008.

⁸ Caldwell (1962), Dodd (1988).

⁹ Richardson *et al.* (1978); Bjorndal *et al.* (1983); Ehrhart, unpublished data.

¹⁰ Melissa Snover, NMFS, personal communication, 2005; see Table A1-6.

¹¹ Dahlen *et al.* (2000).

Population Dynamics and Status

By far, the majority of Atlantic nesting occurs on beaches of the southeastern United States (NMFS and USFWS 2007a). For the past decade or so, the scientific literature has recognized five distinct nesting groups, or subpopulations, of loggerhead sea turtles in the Northwest Atlantic, divided geographically as follows: (1) a northern group of nesting females that nest from North Carolina to northeast Florida at about 29° N latitude; (2) a south Florida group of nesting females that nest from 29° N latitude on the east coast to Sarasota on the west coast; (3) a Florida Panhandle group of

nesting females that nest around Eglin Air Force Base and the beaches near Panama City, Florida; (4) a Yucatán group of nesting females that nest on beaches of the eastern Yucatán Peninsula, Mexico; and (5) a Dry Tortugas group that nests on beaches of the islands of the Dry Tortugas, near Key West, Florida and on Cal Sal Bank (TEWG 2009). Genetic analyses of mitochondrial DNA, which a sea turtle inherits from its mother, indicate that there are genetic differences between loggerheads that nest at and originate from the beaches used by each of the five identified nesting groups of females (TEWG 2009). However, analyses of microsatellite loci from nuclear DNA, which represents the genetic contribution from both parents, indicates little to no genetic differences between loggerheads originating from nesting beaches of the five Northwest Atlantic nesting groups (Pearce and Bowen 2001; Bowen 2003; Bowen *et al.* 2005; Shamblin 2007). These results suggest that female loggerheads have site fidelity to nesting beaches within a particular area, while males provide an avenue of gene flow between nesting groups by mating with females that originate from different nesting groups (Bowen 2003; Bowen *et al.* 2005). The extent of such gene flow, however, is unclear (Shamblin 2007).

The lack of genetic structure makes it difficult to designate specific boundaries for the nesting subpopulations based on genetic differences alone. Therefore, the Loggerhead Recovery Team recently used a combination of geographic distribution of nesting densities, geographic separation, and geopolitical boundaries, in addition to genetic differences, to reassess the designation of these subpopulations to identify recovery units in the 2008 recovery plan.

In the 2008 recovery plan, the Loggerhead Recovery Team designated five recovery units for the Northwest Atlantic population of loggerhead sea turtles based on the aforementioned nesting groups and inclusive of a few other nesting areas not mentioned above. The first four of these recovery units represent nesting assemblages located in the Southeast United States. The fifth recovery unit is composed of all other nesting assemblages of loggerheads within the Greater Caribbean, outside the United States, but which occur within U.S. waters during some portion of their lives. The five recovery units representing nesting assemblages are: (1) the Northern Recovery Unit (NRU: Florida/Georgia border through southern Virginia), (2) the Peninsular Florida Recovery Unit (PFRU: Florida/Georgia border through Pinellas County, Florida), (3) the Dry Tortugas Recovery Unit (DTRU: islands located west of Key West, Florida), (4) the Northern Gulf of Mexico Recovery Unit (NGMRU: Franklin County, Florida through Texas), and (5) the Greater Caribbean Recovery Unit (GCRU: Mexico through French Guiana, Bahamas, Lesser Antilles, and Greater Antilles).

The Recovery Team evaluated the status and trends of the Northwest Atlantic loggerhead population for each of the five recovery units, using nesting data available as of October 2008 (NMFS and USFWS 2008). The level and consistency of nesting coverage varies among recovery units, with coverage in Florida generally being the most consistent and thorough over time. Since 1989, nest count surveys in Florida have occurred in the form of statewide surveys (a near complete census of entire Florida nesting) and index beach surveys (Witherington *et al.* 2009). Index beaches were established to standardize data collection methods and maintain a constant level of effort on key nesting beaches over time.

Note that NMFS and USFWS (2008), Witherington *et al.* (2009), and TEWG (2009) analyzed the status of the nesting assemblages within the NWA DPS using standardized data collected over periods ranging from 10-23 years. These analyses used different analytical approaches, but found

the same finding that there had been a significant, overall nesting decline within the NWA DPS. However, with the addition of nesting data from 2008-2010, the trend line changes showing a very slight negative trend, but the rate of decline is not statistically different from zero (76 FR 58868, September 22, 2011). The nesting data presented in the Recovery Plan (through 2008) is described below, with updated trend information through 2010 for two recovery units.

From the beginning of standardized index surveys in 1989 until 1998, the PFRU, the largest nesting assemblage in the Northwest Atlantic by an order of magnitude, had a significant increase in the number of nests. However, from 1998 through 2008, there was a 41% decrease in annual nest counts from index beaches, which represent an average of 70% of the statewide nesting activity (NMFS and USFWS 2008). From 1989-2008, the PFRU had an overall declining nesting trend of 26% (95% CI: -42% to -5%; NMFS and USFWS 2008). With the addition of nesting data through 2010, the nesting trend for the PFRU does not show a nesting decline statistically different from zero (76 FR 58868, September 22, 2011). The NRU, the second largest nesting assemblage of loggerheads in the United States, has been declining at a rate of 1.3% annually since 1983 (NMFS and USFWS 2008). The NRU dataset included 11 beaches with an uninterrupted time series of coverage of at least 20 years; these beaches represent approximately 27% of NRU nesting (in 2008). Through 2008, there was strong statistical data to suggest the NRU has experienced a long-term decline, but with the inclusion of nesting data through 2010, nesting for the NRU is showing possible signs of stabilizing (76 FR 58868, September 22, 2011). Evaluation of long-term nesting trends for the NGMRU is difficult because of changed and expanded beach coverage. However, the NGMRU has shown a significant declining trend of 4.7% annually since index nesting beach surveys were initiated in 1997 (NMFS and USFWS 2008). No statistical trends in nesting abundance can be determined for the DTRU because of the lack of long-term data. Similarly, statistically valid analyses of long-term nesting trends for the entire GCRU are not available because there are few long-term standardized nesting surveys representative of the region. Additionally, changing survey effort at monitored beaches and scattered and low-level nesting by loggerheads at many locations currently precludes comprehensive analyses (NMFS and USFWS 2008).

Sea turtle census nesting surveys are important in that they provide information on the relative abundance of nesting each year, and the contribution of each nesting group to total nesting of the species. Nest counts can also be used to estimate the number of reproductively mature females nesting annually. The 2008 recovery plan compiled information on mean number of loggerhead nests and the approximated counts of nesting females per year for four of the five identified recovery units (*i.e.*, nesting groups). They are: (1) for the NRU, a mean of 5,215 loggerhead nests per year (from 1989-2008) with approximately 1,272 females nesting per year; (2) for the PFRU, a mean of 64,513 nests per year (from 1989-2007) with approximately 15,735 females nesting per year; (3) for the DTRU, a mean of 246 nests per year (from 1995-2004, excluding 2002) with approximately 60 females nesting per year; and (4) for the NGMRU, a mean of 906 nests per year (from 1995-2007) with approximately 221 females nesting per year. For the GCRU, the only estimate available for the number of loggerhead nests per year is from Quintana Roo, Yucatán, Mexico, where a range of 903-2,331 nests per year was estimated from 1987-2001 (NMFS and USFWS 2007a). There are no annual nest estimates available for the Yucatán since 2001 or for any other regions in the GCRU, nor are there any estimates of the number of nesting females per year for any nesting assemblage in this recovery unit. Note that the above values for average nesting

females per year were based upon 4.1 nests per female per Murphy and Hopkins (1984).

Genetic studies of juvenile and a few adult loggerhead sea turtles collected from Northwest Atlantic foraging areas (beach strandings, a power plant in Florida, and North Carolina fisheries) show that the loggerheads that occupy East Coast U.S. waters originate from these Northwest Atlantic nesting groups; primarily from the nearby nesting beaches of southern Florida, as well as the northern Florida to North Carolina beaches, and finally from the beaches of the Yucatán Peninsula, Mexico (Rankin-Baransky *et al.* 2001; Witzell *et al.* 2002; Bass *et al.* 2004; Bowen *et al.* 2004). The contribution of these three nesting assemblages varies somewhat among the foraging habitats and age classes surveyed along the east coast. The distribution is not random and bears a significant relationship to the proximity and size of adjacent nesting colonies (Bowen *et al.* 2004). Bass *et al.* (2004) attribute the variety in the proportions of sea turtles from loggerhead turtle nesting assemblages documented in different east coast foraging habitats to a complex interplay of currents and the relative size and proximity of nesting beaches.

Unlike nesting surveys, in-water studies of sea turtles typically sample both sexes and multiple age classes. In-water studies have been conducted in some areas of the Northwest Atlantic and provide data by which to assess the relative abundance of loggerhead sea turtles and changes in abundance over time (Maier *et al.* 2004; Morreale *et al.* 2005; Mansfield 2006; Ehrhart *et al.* 2007; Epperly *et al.* 2007). The TEWG (2009) used raw data from six in-water study sites to conduct trend analyses. They identified an increasing trend in the abundance of loggerheads from three of the four sites located in the Southeast United States, one site showed no discernible trend, and the two sites located in the northeast United States showed a decreasing trend in abundance of loggerheads. The 2008 loggerhead recovery plan also includes a full discussion of in-water population studies for which trend data have been reported, and a brief summary will be provided here.

Maier *et al.* (2004) used fishery-independent trawl data to establish a regional index of loggerhead abundance for the southeast coast of the United States (Winyah Bay, South Carolina to St. Augustine, Florida) during the period 2000-2003. A comparison of loggerhead catch data from this study with historical values suggested that in-water populations of loggerhead sea turtles along the southeast U.S. coast appear to be larger, possibly an order of magnitude higher than they were 25 years ago, but the authors caution a direct comparison between the two studies given differences in sampling methodology (Maier *et al.* 2004). A comparison of catch rates for sea turtles in pound net gear fished in the Pamlico-Albemarle Estuarine Complex of North Carolina between the years 1995-1997 and 2001-2003 found a significant increase in catch rates for loggerhead sea turtles for the latter period (Epperly *et al.* 2007). A long-term, on-going study of loggerhead abundance in the Indian River Lagoon System of Florida found a significant increase in the relative abundance of loggerheads over the last 4 years of the study (Ehrhart *et al.* 2007). However, there was no discernible trend in loggerhead abundance during the 24-year time period of the study (1982-2006) (Ehrhart *et al.* 2007). At St. Lucie Power Plant, data collected from 1977-2004 show an increasing trend of loggerheads at the power plant intake structures (FPL and Quantum Resources 2005).

In contrast to these studies, Morreale *et al.* (2005) observed a decline in the percentage and relative numbers of loggerhead sea turtles incidentally captured in pound net gear fished around Long Island, New York during the period 2002-2004 in comparison to the period 1987-1992, with only two loggerheads (of a total 54 turtles) observed captured in pound net gear during the period 2002-

2004. This is in contrast to the previous decade's study where numbers of individual loggerheads ranged from 11 to 28 per year (Morreale *et al.* 2005). No additional loggerheads were reported captured in pound net gear in New York through 2007, although two were found cold-stunned on Long Island bay beaches in the fall of 2007 (Memo to the File, L. Lankshear, December 2007). Potential explanations for this decline include major shifts in loggerhead foraging areas and/or increased mortality in pelagic or early benthic stage/age classes (Morreale *et al.* 2005). Using aerial surveys, Mansfield (2006) also found a decline in the densities of loggerhead sea turtles in Chesapeake Bay over the period 2001-2004 compared to aerial survey data collected in the 1980s. Significantly fewer loggerheads ($p < 0.05$) were observed in both the spring (May-June) and the summer (July-August) of 2001-2004 compared to those observed during aerial surveys in the 1980s (Mansfield 2006). A comparison of median densities from the 1980s to the 2000s suggested that there had been a 63.2% reduction in densities during the spring residency period and a 74.9% reduction in densities during the summer residency period (Mansfield 2006). The decline in observed loggerhead populations in Chesapeake Bay may be related to a significant decline in prey, namely horseshoe crabs and blue crabs, with loggerheads redistributing outside of Bay waters (NMFS and USFWS 2008).

As with other turtle species, population estimates for loggerhead sea turtles are difficult to determine, largely given their life history characteristics. However, a recent loggerhead assessment using a demographic matrix model estimated that the loggerhead adult female population in the western North Atlantic ranges from 16,847 to 89,649, with a median size of 30,050 (NMFS SEFSC 2009). The model results for population trajectory suggest that the population is most likely declining, but this result was very sensitive to the choice of the position of the parameters within their range and hypothesized distributions. The pelagic stage survival parameter had the largest effect on the model results. As a result of the large uncertainty in our knowledge of loggerhead life history, at this point predicting the future populations or population trajectories of loggerhead sea turtles with precision is very uncertain. It should also be noted that additional analyses are underway which will incorporate any newly available information.

As part of the Atlantic Marine Assessment Program for Protected Species (AMAPPS), line transect aerial abundance surveys and turtle telemetry studies were conducted along the Atlantic coast in the summer of 2010. AMAPPS is a multi-agency initiative to assess marine mammal, sea turtle, and seabird abundance and distribution in the Atlantic. Aerial surveys were conducted from Cape Canaveral, Florida to the Gulf of St. Lawrence, Canada. Satellite tags on juvenile loggerheads were deployed in two locations – off the coasts of northern Florida to South Carolina ($n=30$) and off the New Jersey and Delaware coasts ($n=14$). As presented in NMFS NEFSC (2011), the 2010 survey found a preliminary total surface abundance estimate within the entire study area of about 60,000 loggerheads ($CV=0.13$) or 85,000 if a portion of unidentified hard-shelled sea turtles were included ($CV=0.10$). Surfacing times were generated from the satellite tag data collected during the aerial survey period, resulting in a 7% (5%-11% inter-quartile range) median surface time in the South Atlantic area and a 67% (57%-77% inter-quartile range) median surface time to the north. The calculated preliminary regional abundance estimate is about 588,000 loggerheads along the U.S. Atlantic coast, with an inter-quartile range of 382,000-817,000 (NMFS NEFSC 2011). The estimate increases to approximately 801,000 (inter-quartile range of 521,000-1,111,000) when based on known loggerheads and a portion of unidentified turtle sightings. The density of loggerheads was generally lower in the north than the south; based on number of turtle groups detected, 64%

were seen south of Cape Hatteras, North Carolina, 30% in the southern Mid-Atlantic Bight, and 6% in the northern Mid-Atlantic Bight. Although they have been seen farther north in previous studies (*e.g.*, Shoop and Kenney 1992), no loggerheads were observed during the aerial surveys conducted in the summer of 2010 in the more northern zone encompassing Georges Bank, Cape Cod Bay, and the Gulf of Maine. These estimates of loggerhead abundance over the U.S. Atlantic continental shelf are considered very preliminary. A more thorough analysis will be completed pending the results of further studies related to improving estimates of regional and seasonal variation in loggerhead surface time (by increasing the sample size and geographical area of tagging) and other information needed to improve the biases inherent in aerial surveys of sea turtles (*e.g.*, research on depth of detection and species misidentification rate). This survey effort represents the most comprehensive assessment of sea turtle abundance and distribution in many years. Additional aerial surveys and research to improve the abundance estimates are anticipated in 2011-2014, depending on available funds.

Threats

The diversity of a sea turtle's life history leaves them susceptible to many natural and human impacts, including impacts while they are on land, in the neritic environment, and in the oceanic environment. The 5-year status review and 2008 recovery plan provide a summary of natural as well as anthropogenic threats to loggerhead sea turtles (NMFS and USFWS 2007a, 2008). Amongst those of natural origin, hurricanes are known to be destructive to sea turtle nests. Sand accretion, rainfall, and wave action that result from these storms can appreciably reduce hatchling success. Other sources of natural mortality include cold-stunning, biotoxin exposure, and native species predation.

Anthropogenic factors that impact hatchlings and adult females on land, or the success of nesting and hatching include: beach erosion, beach armoring, and nourishment; artificial lighting; beach cleaning; beach pollution; increased human presence; recreational beach equipment; vehicular and pedestrian traffic; coastal development/construction; exotic dune and beach vegetation; removal of native vegetation; and poaching. An increased human presence at some nesting beaches or close to nesting beaches has led to secondary threats such as the introduction of exotic fire ants, feral hogs, dogs, and an increased presence of native species (*e.g.*, raccoons, armadillos, and opossums), which raid nests and feed on turtle eggs (NMFS and USFWS 2007a, 2008). Although sea turtle nesting beaches are protected along large expanses of the Northwest Atlantic coast (in areas like Merritt Island, Archie Carr, and Hobe Sound National Wildlife Refuges), other areas along these coasts have limited or no protection. Sea turtle nesting and hatching success on unprotected high density East Florida nesting beaches from Indian River to Broward County are affected by all of the above threats.

Loggerheads are affected by a completely different set of anthropogenic threats in the marine environment. These include oil and gas exploration, coastal development, and transportation; marine pollution; underwater explosions; hopper dredging; offshore artificial lighting; power plant entrainment and/or impingement; entanglement in debris; ingestion of marine debris; marina and dock construction and operation; boat collisions; poaching; and fishery interactions.

A 1990 National Research Council (NRC) report concluded that for juveniles, subadults, and breeding adults in coastal waters, the most important source of human caused mortality in U.S.

Atlantic waters was fishery interactions. The sizes and reproductive values of sea turtles taken by fisheries vary significantly, depending on the location and season of the fishery, and size-selectivity resulting from gear characteristics. Therefore, it is possible for fisheries that interact with fewer, more reproductively valuable turtles to have a greater detrimental effect on the population than one that takes greater numbers of less reproductively valuable turtles (Wallace *et al.* 2008). The Loggerhead Biological Review Team determined that the greatest threats to the NWA DPS of loggerheads result from cumulative fishery bycatch in neritic and oceanic habitats (Conant *et al.* 2009). Attaining a more thorough understanding of the characteristics, as well as the quantity of sea turtle bycatch across all fisheries is of great importance.

Finkbeiner *et al.* (2011) compiled cumulative sea turtle bycatch information in U.S. fisheries from 1990 through 2007, before and after implementation of bycatch mitigation measures. Information was obtained from peer reviewed publications and NMFS documents (e.g., Biological Opinions and bycatch reports). In the Atlantic, a mean estimate of 137,700 bycatch interactions, of which 4,500 were mortalities, occurred annually (since implementation of bycatch mitigation measures). Kemp's ridleys interacted with fisheries most frequently, with the highest level of mean annual mortality (2,700), followed by loggerheads (1,400), greens (300), and leatherbacks (40). The Southeast/Gulf of Mexico shrimp trawl fishery was responsible for the vast majority of U.S. interactions (up to 98%) and mortalities (more than 80%). While this provides an initial cumulative bycatch assessment, there are a number of caveats that should be considered when interpreting this information, such as sampling inconsistencies and limitations.

Of the many fisheries known to adversely affect loggerheads, the U.S. South Atlantic and Gulf of Mexico shrimp fisheries were considered to pose the greatest threat of mortality to neritic juvenile and adult age classes of loggerheads (NRC 1990, Finkbeiner *et al.* 2011). Significant changes to the South Atlantic and Gulf of Mexico shrimp fisheries have occurred since 1990, and the effects of these shrimp fisheries on ESA-listed species, including loggerhead sea turtles, have been assessed several times through section 7 consultation. There is also a lengthy regulatory history with regard to the use of Turtle Excluder Devices (TEDs) in the U.S. South Atlantic and Gulf of Mexico shrimp fisheries (Epperly and Teas 2002; NMFS 2002a; Lewison *et al.* 2003). The current section 7 consultation on the U.S. South Atlantic and Gulf of Mexico shrimp fisheries was completed in 2002 and estimated the total annual level of take for loggerhead sea turtles to be 163,160 interactions (the total number of turtles that enter a shrimp trawl, which may then escape through the TED or fail to escape and be captured) with 3,948 of those takes being lethal (NMFS 2002a).

In addition to improvements in TED designs and TED enforcement, interactions between loggerheads and the shrimp fishery have also been declining because of reductions in fishing effort unrelated to fisheries management actions. The 2002 Opinion take estimates are based in part on fishery effort levels. In recent years, low shrimp prices, rising fuel costs, competition with imported products, and the impacts of recent hurricanes in the Gulf of Mexico have all impacted the shrimp fleets; in some cases reducing fishing effort by as much as 50% for offshore waters of the Gulf of Mexico (GMFMC 2007). As a result, loggerhead interactions and mortalities in the Gulf of Mexico have been substantially less than projected in the 2002 Opinion. In 2008, the estimated annual number of interactions between loggerheads and shrimp trawls in the Gulf of Mexico shrimp fishery was 23,336, with 647 (2.8%) of those interactions resulting in mortality (Memo from Dr. B. Ponwith, Southeast Fisheries Science Center to Dr. R. Crabtree, Southeast Region, PRD, December

2008). A new Biological Opinion on the Shrimp FMP was completed in May 2012; this Opinion does not contain a quantitative estimate of the number of interactions between loggerheads and the shrimp fishery.

Loggerhead sea turtles are also known to interact with non-shrimp trawl, gillnet, longline, dredge, pound net, pot/trap, and hook and line fisheries. The NRC (1990) report stated that other U.S. Atlantic fisheries collectively accounted for 500 to 5,000 loggerhead deaths each year, but recognized that there was considerable uncertainty in the estimate. The reduction of sea turtle captures in fishing operations is identified in recovery plans and 5-year status reviews as a priority for the recovery of all sea turtle species. In the threats analysis of the loggerhead recovery plan, trawl bycatch is identified as the greatest source of mortality. While loggerhead bycatch in U.S. Mid-Atlantic bottom otter trawl gear was previously estimated for the period 1996-2004 (Murray 2006, 2008), a recent bycatch analysis estimated the number of loggerhead sea turtle interactions with U.S. Mid-Atlantic bottom trawl gear from 2005-2008 (Warden 2011a). Northeast Fisheries Observer Program data from 1994-2008 were used to develop a model of interaction rates and those predicted rates were applied to 2005-2008 commercial fishing data to estimate the number of interactions for the trawl fleet. The number of predicted average annual loggerhead interactions for 2005-2008 was 292 (CV=0.13, 95% CI=221-369), with an additional 61 loggerheads (CV=0.17, 95% CI=41-83) interacting with trawls but being released through a TED. Of the 292 average annual observable loggerhead interactions, approximately 44 of those were adult equivalents. Warden (2011b) found that latitude, depth and SST were associated with the interaction rate, with the rates being highest south of 37°N latitude in waters < 50 m deep and SST > 15°C. This estimate is a decrease from the average annual loggerhead bycatch in bottom otter trawls during 1996-2004, estimated to be 616 sea turtles (CV=0.23, 95% CI over the 9-year period: 367-890) (Murray 2006, 2008).

There have been several published estimates of the number of loggerheads taken annually as a result of the dredge fishery for Atlantic sea scallops, ranging from a low of zero in 2005 (Murray 2007) to a high of 749 in 2003 (Murray 2004). Murray (2011) recently re-evaluated loggerhead sea turtle interactions in scallop dredge gear from 2001-2008. In that paper, the average number of annual observable interactions of hard-shelled sea turtles in the Mid-Atlantic scallop dredge fishery prior to the implementation of chain mats (January 1, 2001 through September 25, 2006) was estimated to be 288 turtles (CV = 0.14, 95% CI: 209-363) [equivalent to 49 adults], 218 of which were loggerheads [equivalent to 37 adults]. After the implementation of chain mats, the average annual number of observable interactions was estimated to be 20 hard-shelled sea turtles (CV = 0.48, 95% CI: 3-42), 19 of which were loggerheads. If the rate of observable interactions from dredges without chain mats had been applied to trips with chain mats, the estimated number of observable and inferred interactions of hard-shelled sea turtles after chain mats were implemented would have been 125 turtles per year (CV = 0.15, 95% CI: 88-163) [equivalent to 22 adults], 95 of which were loggerheads [equivalent to 16 adults]. Interaction rates of hard-shelled turtles were correlated with sea surface temperature, depth, and use of a chain mat. Results from this recent analysis suggest that chain mats and fishing effort reductions have contributed to the decline in estimated loggerhead sea turtle interactions with scallop dredge gear after 2006 (Murray 2011).

An estimate of the number of loggerheads taken annually in U.S. Mid-Atlantic gillnet fisheries has also recently been published (Murray 2009a, b). From 1995-2006, the annual bycatch of

loggerheads in U.S. Mid-Atlantic gillnet gear was estimated to average 350 turtles (CV=0.20, 95% CI over the 12-year period: 234 to 504). Bycatch rates were correlated with latitude, sea surface temperature, and mesh size. The highest predicted bycatch rates occurred in warm waters of the southern Mid-Atlantic in large-mesh gillnets (Murray 2009a).

The U.S. tuna and swordfish longline fisheries that are managed under the Highly Migratory Species (HMS) FMP are estimated to capture 1,905 loggerheads (no more than 339 mortalities) for each 3-year period starting in 2007 (NMFS 2004a). NMFS has mandated gear changes for the HMS fishery to reduce sea turtle bycatch and the likelihood of death from those incidental takes that would still occur (Garrison and Stokes 2010). In 2010, there were 40 observed interactions between loggerhead sea turtles and longline gear used in the HMS fishery (Garrison and Stokes 2011a, 2011b). All of the loggerheads were released alive, with the vast majority released with all gear removed. While 2010 total estimates are not yet available, in 2009, 242.9 (95% CI: 167.9-351.2) loggerhead sea turtles are estimated to have been taken in the longline fisheries managed under the HMS FMP based on the observed takes (Garrison and Stokes 2010). The 2009 estimate is considerably lower than those in 2006 and 2007 and is consistent with historical averages since 2001 (Garrison and Stokes 2010). This fishery represents just one of several longline fisheries operating in the Atlantic Ocean. Lewison *et al.* (2004) estimated that 150,000-200,000 loggerheads were taken in all Atlantic longline fisheries in 2000 (including the U.S. Atlantic tuna and swordfish longline fisheries as well as others).

Documented takes also occur in other fishery gear types and by non-fishery mortality sources (*e.g.*, hopper dredges, power plants, vessel collisions), but quantitative estimates are unavailable. Past and future impacts of global climate change are considered in Section 6.0 below.

Summary of Status for Loggerhead Sea Turtles

Loggerheads are a long-lived species and reach sexual maturity relatively late at around 32-35 years in the Northwest Atlantic (NMFS and USFWS 2008). The species continues to be affected by many factors occurring on nesting beaches and in the water. These include poaching, habitat loss, and nesting predation that affects eggs, hatchlings, and nesting females on land, as well as fishery interactions, vessel interactions, marine pollution, and non-fishery (*e.g.*, dredging) operations affecting all sexes and age classes in the water (NRC 1990; NMFS and USFWS 2007a, 2008). As a result, loggerheads still face many of the original threats that were the cause of their listing under the ESA.

As mentioned previously, a final revised recovery plan for loggerhead sea turtles in the Northwest Atlantic was recently published by NMFS and FWS in December 2008. The revised recovery plan is significant in that it identifies five unique recovery units, which comprise the population of loggerheads in the Northwest Atlantic, and describes specific recovery criteria for each recovery unit. The recovery plan noted a decline in annual nest counts for three of the five recovery units for loggerheads in the Northwest Atlantic, including the PFRU, which is the largest (in terms of number of nests laid) in the Atlantic Ocean. The nesting trends for the other two recovery units could not be determined due to an absence of long term data.

NMFS convened a new Loggerhead Turtle Expert Working Group (TEWG) to review all available information on Atlantic loggerheads in order to evaluate the status of this species in the Atlantic. A

final report from the Loggerhead TEWG was published in July 2009. In this report, the TEWG indicated that it could not determine whether the decreasing annual numbers of nests among the Northwest Atlantic loggerhead subpopulations were due to stochastic processes resulting in fewer nests, a decreasing average reproductive output of adult females, decreasing numbers of adult females, or a combination of these factors. Many factors are responsible for past or present loggerhead mortality that could impact current nest numbers; however, no single mortality factor stands out as a likely primary factor. It is likely that several factors compound to create the current decline, including incidental capture (in fisheries, power plant intakes, and dredging operations), lower adult female survival rates, increases in the proportion of first-time nesters, continued directed harvest, and increases in mortality due to disease. Regardless, the TEWG stated that “it is clear that the current levels of hatchling output will result in depressed recruitment to subsequent life stages over the coming decades” (TEWG 2009). However, the report does not provide information on the rate or amount of expected decrease in recruitment but goes on to state that the ability to assess the current status of loggerhead subpopulations is limited due to a lack of fundamental life history information and specific census and mortality data.

While several documents reported the decline in nesting numbers in the NWA DPS (NMFS and USFWS 2008, TEWG 2009), when nest counts through 2010 are analyzed, the nesting trends from 1989-2010 are not significantly different than zero for all recovery units within the NWA DPS for which there are enough data to analyze (76 FR 58868, September 22, 2011). The SEFSC (2009) estimated the number of adult females in the NWA DPS at 30,000, and if a 1:1 adult sex ratio is assumed, the result is 60,000 adults in this DPS. Based on the reviews of nesting data, as well as information on population abundance and trends, NMFS and USFWS determined in the September 2011 listing rule that the NWA DPS should be listed as threatened. They found that an endangered status for the NWA DPS was not warranted given the large size of the nesting population, the overall nesting population remains widespread, the trend for the nesting population appears to be stabilizing, and substantial conservation efforts are underway to address threats.

5.3 Status of Kemp’s Ridley Sea Turtles

Distribution and Life History

The Kemp’s ridley is one of the least abundant of the world’s sea turtle species. In contrast to loggerhead, leatherback, and green sea turtles, which are found in multiple oceans of the world, Kemp’s ridleys typically occur only in the Gulf of Mexico and the northwestern Atlantic Ocean (NMFS *et al.* 2011).

Kemp’s ridleys mature at 10-17 years (Caillouet *et al.* 1995; Schmid and Witzell 1997; Snover *et al.* 2007; NMFS and USFWS 2007c). Nesting occurs from April through July each year with hatchlings emerging after 45-58 days (NMFS *et al.* 2011). Females lay an average of 2.5 clutches within a season (TEWG 1998, 2000) and the mean remigration interval for adult females is 2 years (Marquez *et al.* 1982; TEWG 1998, 2000).

Once they leave the nesting beach, hatchlings presumably enter the Gulf of Mexico where they feed on available *Sargassum* and associated infauna or other epipelagic species (NMFS *et al.* 2011). The presence of juvenile turtles along both the U.S. Atlantic and Gulf of Mexico coasts, where they are

recruited to the coastal benthic environment, indicates that post-hatchlings are distributed in both the Gulf of Mexico and Atlantic Ocean (TEWG 2000).

The location and size classes of dead turtles recovered by the STSSN suggests that benthic immature developmental areas occur along the U.S. coast and that these areas may change given resource quality and quantity (TEWG 2000). Developmental habitats are defined by several characteristics, including coastal areas sheltered from high winds and waves such as embayments and estuaries, and nearshore temperate waters shallower than 50 m (NMFS and USFWS 2007c). The suitability of these habitats depends on resource availability, with optimal environments providing rich sources of crabs and other invertebrates. Kemp's ridleys consume a variety of crab species, including *Callinectes*, *Ovalipes*, *Libinia*, and *Cancer* species. Mollusks, shrimp, and fish are consumed less frequently (Bjorndal 1997). A wide variety of substrates have been documented to provide good foraging habitat, including seagrass beds, oyster reefs, sandy and mud bottoms, and rock outcroppings (NMFS and USFWS 2007c).

Foraging areas documented along the U.S. Atlantic coast include Charleston Harbor, Pamlico Sound (Epperly *et al.* 1995c), Chesapeake Bay (Musick and Limpus 1997), Delaware Bay (Stetzar 2002), and Long Island Sound (Morreale and Standora 1993; Morreale *et al.* 2005). For instance, in the Chesapeake Bay, Kemp's ridleys frequently forage in submerged aquatic grass beds for crabs (Musick and Limpus 1997).

Upon leaving Chesapeake Bay in autumn, juvenile Kemp's ridleys migrate down the coast, passing Cape Hatteras in December and January (Musick and Limpus 1997). These larger juveniles are joined by juveniles of the same size from North Carolina sounds and smaller juveniles from New York and New England to form one of the densest concentrations of Kemp's ridleys outside of the Gulf of Mexico (Epperly *et al.* 1995a, 1995b; Musick and Limpus 1997).

Adult Kemp's ridleys are found in the coastal regions of the Gulf of Mexico and southeastern United States, but are typically rare in the northeastern U.S. waters of the Atlantic (TEWG 2000). Adults are primarily found in nearshore waters of 37 m or less that are rich in crabs and have a sandy or muddy bottom (NMFS and USFWS 2007c).

Population Dynamics and Status

The majority of Kemp's ridleys nest along a single stretch of beach near Rancho Nuevo, Tamaulipas, Mexico (Carr 1963; NMFS and USFWS 2007c; NMFS *et al.* 2011). There is a limited amount of scattered nesting to the north and south of the primary nesting beach (NMFS and USFWS 2007c). Nesting often occurs in synchronized emergences termed *arribadas*. The number of recorded nests reached an estimated low of 702 nests in 1985, corresponding to fewer than 300 adult females nesting in that season (TEWG 2000; NMFS and USFWS 2007c; NMFS *et al.* 2011). Conservation efforts by Mexican and U.S. agencies have aided this species by eliminating egg harvest, protecting eggs and hatchlings, and reducing at-sea mortality through fishing regulations (TEWG 2000). Since the mid-1980s, the number of nests observed at Rancho Nuevo and nearby beaches has increased 14-16% per year (Heppell *et al.* 2005), allowing cautious optimism that the population is on its way to recovery. An estimated 5,500 females nested in the State of Tamaulipas over a 3-day period in May 2007 and over 4,000 of those nested at Rancho Nuevo (NMFS and USFWS 2007c). In 2008, 17,882 nests were documented on Mexican nesting beaches (NMFS

2011). There is limited nesting in the United States, most of which is located in South Texas. While six nests were documented in 1996, a record 195 nests were found in 2008 (NMFS 2011).

Threats

Kemp's ridleys face many of the same natural threats as loggerheads, including destruction of nesting habitat from storm events, predators, and oceanographic-related events such as cold-stunning. Although cold-stunning can occur throughout the range of the species, it may be a greater risk for sea turtles that utilize the more northern habitats of Cape Cod Bay and Long Island Sound. In the last five years (2006-2010), the number of cold-stunned turtles on Cape Cod beaches averaged 115 Kemp's ridleys, 7 loggerheads, and 7 greens (NMFS unpublished data). The numbers ranged from a low in 2007 of 27 Kemp's ridleys, 5 loggerheads, and 5 greens to a high in 2010 of 213 Kemp's ridleys, 4 loggerheads, and 14 greens. Annual cold stun events vary in magnitude; the extent of episodic major cold stun events may be associated with numbers of turtles utilizing Northeast U.S. waters in a given year, oceanographic conditions, and/or the occurrence of storm events in the late fall. Although many cold-stunned turtles can survive if they are found early enough, these events represent a significant source of natural mortality for Kemp's ridleys.

Like other sea turtle species, the severe decline in the Kemp's ridley population appears to have been heavily influenced by a combination of exploitation of eggs and impacts from fishery interactions. From the 1940s through the early 1960s, nests from Ranch Nuevo were heavily exploited, but beach protection in 1967 helped to curtail this activity (NMFS *et al.* 2011). Following World War II, there was a substantial increase in the number of trawl vessels, particularly shrimp trawlers, in the Gulf of Mexico where adult Kemp's ridley sea turtles occur. Information from fisheries observers helped to demonstrate the high number of turtles taken in these shrimp trawls (USFWS and NMFS 1992). Subsequently, NMFS has worked with the industry to reduce sea turtle takes in shrimp trawls and other trawl fisheries, including the development and use of turtle excluder devices (TEDs). As described above, there is lengthy regulatory history with regard to the use of TEDs in the U.S. South Atlantic and Gulf of Mexico shrimp fisheries (NMFS 2002a; Epperly 2003; Lewison *et al.* 2003). The 2002 Biological Opinion on shrimp trawling in the southeastern United States concluded that 155,503 Kemp's ridley sea turtles would be taken annually in the fishery with 4,208 of the takes resulting in mortality (NMFS 2002a).

Although modifications to shrimp trawls have helped to reduce mortality of Kemp's ridleys, a recent assessment found that the Southeast/Gulf of Mexico shrimp trawl fishery remained responsible for the vast majority of U.S. fishery interactions (up to 98%) and mortalities (more than 80%). Finkbeiner *et al.* (2011) compiled cumulative sea turtle bycatch information in U.S. fisheries from 1990 through 2007, before and after implementation of bycatch mitigation measures. Information was obtained from peer reviewed publications and NMFS documents (e.g., Biological Opinions and bycatch reports). In the Atlantic, a mean estimate of 137,700 bycatch interactions, of which 4,500 were mortalities, occurred annually (since implementation of bycatch mitigation measures). Kemp's ridleys interacted with fisheries most frequently, with the highest level of mean annual mortality (2,700), followed by loggerheads (1,400), greens (300), and leatherbacks (40). While this provides an initial cumulative bycatch assessment, there are a number of caveats that should be considered when interpreting this information, such as sampling inconsistencies and limitations.

This species is also affected by other sources of anthropogenic impact (fishery and non-fishery related), similar to those discussed above. Three Kemp's ridley captures in Mid-Atlantic trawl fisheries were documented by NMFS observers between 1994 and 2008 (Warden and Bisack 2010), and eight Kemp's ridleys were documented by NMFS observers in mid-Atlantic sink gillnet fisheries between 1995 and 2006 (Murray 2009a). Additionally, in the spring of 2000, a total of five Kemp's ridley carcasses were recovered from the same North Carolina beaches where 275 loggerhead carcasses were found. The cause of death for most of the turtles recovered was unknown, but the mass mortality event was suspected by NMFS to have been from a large-mesh gillnet fishery for monkfish and dogfish operating offshore in the preceding weeks (67 FR 71895, December 3, 2002). The five Kemp's ridley carcasses that were found are likely to have been only a minimum count of the number of Kemp's ridleys that were killed or seriously injured as a result of the fishery interaction, since it is unlikely that all of the carcasses washed ashore. The NMFS Northeast Fisheries Science Center also documented 14 Kemp's ridleys entangled in or impinged on Virginia pound net leaders from 2002-2005. Note that bycatch estimates for Kemp's ridleys in various fishing gear types (*e.g.*, trawl, gillnet, dredge) are not available at this time, largely due to the low number of observed interactions precluding a robust estimate. Kemp's ridley interactions in non-fisheries have also been observed; for example, the Oyster Creek Nuclear Generating Station in Barnegat Bay, New Jersey, recorded a total of 27 Kemp's ridleys (15 of which were found alive) impinged or captured on their intake screens from 1992-2006 (NMFS 2006).

Summary of Status for Kemp's Ridley Sea Turtles

The majority of Kemp's ridleys nest along a single stretch of beach near Rancho Nuevo, Tamaulipas, Mexico (Carr 1963; NMFS and USFWS 2007c; NMFS *et al.* 2011). The number of nesting females in the Kemp's ridley population declined dramatically from the late 1940s through the mid-1980s, with an estimated 40,000 nesting females in a single *arribada* in 1947 and fewer than 300 nesting females in the entire 1985 nesting season (TEWG 2000; NMFS *et al.* 2011). However, the total annual number of nests at Rancho Nuevo gradually began to increase in the 1990s (NMFS and USFWS 2007c). Based on the number of nests laid in 2006 and the remigration interval for Kemp's ridley sea turtles (1.8-2 years), there were an estimated 7,000-8,000 adult female Kemp's ridley sea turtles in 2006 (NMFS and USFWS 2007c). The number of adult males in the population is unknown, but sex ratios of hatchlings and immature Kemp's ridleys suggest that the population is female-biased, suggesting that the number of adult males is less than the number of adult females (NMFS and USFWS 2007c). While there is cautious optimism for recovery, events such as the Deepwater Horizon oil release, and stranding events associated increased skimmer trawl use and poor TED compliance in the northern Gulf of Mexico may dampen recent population growth.

As with the other sea turtle species, fishery mortality accounts for a large proportion of annual human-caused mortality outside the nesting beaches, while other activities like dredging, pollution, and habitat destruction account for an unknown level of other mortality. Based on their 5-year status review of the species, NMFS and USFWS (2007c) determined that Kemp's ridley sea turtles should not be reclassified as threatened under the ESA. A revised bi-national recovery plan was published for public comment in 2010, and in September 2011, NMFS, USFWS, and the Services and the Secretary of Environment and Natural Resources, Mexico (SEMARNAT) released the second revision to the Kemp's ridley recovery plan.

5.4 Status of Green Sea Turtles

Green sea turtles are distributed circumglobally, and can be found in the Pacific, Indian, and Atlantic Oceans as well as the Mediterranean Sea (NMFS and USFWS 1991, 2007d; Seminoff 2004). In 1978, the Atlantic population of the green sea turtle was listed as threatened under the ESA, except for the breeding populations in Florida and on the Pacific coast of Mexico, which were listed as endangered. As it is difficult to differentiate between breeding populations away from the nesting beaches, all green sea turtles in the water are considered endangered.

Pacific Ocean

Green sea turtles occur in the western, central, and eastern Pacific. Foraging areas are also found throughout the Pacific and along the southwestern U.S. coast (NMFS and USFWS 1998b). In the western Pacific, major nesting rookeries at four sites including Heron Island (Australia), Raine Island (Australia), Guam, and Japan were evaluated and determined to be increasing in abundance, with the exception of Guam which appears stable (NMFS and USFWS 2007d). In the central Pacific, nesting occurs on French Frigate Shoals, Hawaii, which has also been reported as increasing with a mean of 400 nesting females annually from 2002-2006 (NMFS and USFWS 2007d). The main nesting sites for the green sea turtle in the eastern Pacific are located in Michoacan, Mexico and in the Galapagos Islands, Ecuador (NMFS and USFWS 2007d). The number of nesting females per year exceeds 1,000 females at each site (NMFS and USFWS 2007d). However, historically, greater than 20,000 females per year are believed to have nested in Michoacan alone (Cliffon *et al.* 1982; NMFS and USFWS 2007d). The Pacific Mexico green turtle nesting population (also called the black turtle) is considered endangered.

Historically, green sea turtles were used in many areas of the Pacific for food. They were also commercially exploited, which, coupled with habitat degradation, led to their decline in the Pacific (NMFS and USFWS 1998b). Green sea turtles in the Pacific continue to be affected by poaching, habitat loss or degradation, fishing gear interactions, and fibropapillomatosis, which is a viral disease that causes tumors in affected turtles (NMFS and USFWS 1998b; NMFS 2004b).

Indian Ocean

There are numerous nesting sites for green sea turtles in the Indian Ocean. One of the largest nesting sites for green sea turtles worldwide occurs on the beaches of Oman where an estimated 20,000 green sea turtles nest annually (Hirth 1997; Ferreira *et al.* 2003). Based on a review of the 32 Index Sites used to monitor green sea turtle nesting worldwide, Seminoff (2004) concluded that declines in green sea turtle nesting were evident for many of the Indian Ocean Index Sites. While several of these had not demonstrated further declines in the more recent past, only the Comoros Island Index Site in the western Indian Ocean showed evidence of increased nesting (Seminoff 2004).

Mediterranean Sea

There are four nesting concentrations of green sea turtles in the Mediterranean from which data are available – Turkey, Cyprus, Israel, and Syria. Currently, approximately 300-400 females nest each year, about two-thirds of which nest in Turkey and one-third in Cyprus. Although green sea turtles are depleted from historic levels in the Mediterranean Sea (Kasperek *et al.* 2001), nesting data gathered since the early 1990s in Turkey, Cyprus, and Israel show no apparent trend in any direction. However, a declining trend is apparent along the coast of Palestine/Israel, where 300-350

nests were deposited each year in the 1950s (Sella 1982) compared to a mean of 6 nests per year from 1993-2004 (Kuller 1999; Y. Levy, Israeli Sea Turtle Rescue Center, unpublished data). A recent discovery of green sea turtle nesting in Syria adds roughly 100 nests per year to green sea turtle nesting activity in the Mediterranean (Rees *et al.* 2005). That such a major nesting concentration could have gone unnoticed until recently (the Syria coast was surveyed in 1991, but nesting activity was attributed to loggerheads) bodes well for the ongoing speculation that the unsurveyed coast of Libya may also host substantial nesting.

Atlantic Ocean

Distribution and Life History

As has occurred in other oceans of its range, green sea turtles were once the target of directed fisheries in the United States and throughout the Caribbean. In 1890, over one million pounds of green sea turtles were taken in a directed fishery in the Gulf of Mexico (Doughty 1984). However, declines in the turtle fishery throughout the Gulf of Mexico were evident by 1902 (Doughty 1984).

In the western Atlantic, large juvenile and adult green sea turtles are largely herbivorous, occurring in habitats containing benthic algae and seagrasses from Massachusetts to Argentina, including the Gulf of Mexico and Caribbean (Wynne and Schwartz 1999). Green sea turtles occur seasonally in Mid-Atlantic and Northeast waters such as Chesapeake Bay and Long Island Sound (Musick and Limpus 1997; Morreale and Standora 1998; Morreale *et al.* 2005), which serve as foraging and developmental habitats.

Some of the principal feeding areas in the western Atlantic Ocean include the upper west coast of Florida, the Florida Keys, and the northwestern coast of the Yucatán Peninsula. Additional important foraging areas in the western Atlantic include the Mosquito and Indian River Lagoon systems and nearshore wormrock reefs between Sebastian and Ft. Pierce Inlets in Florida, Florida Bay, the Culebra archipelago and other Puerto Rico coastal waters, the south coast of Cuba, the Mosquito Coast of Nicaragua, the Caribbean coast of Panama, and scattered areas along Colombia and Brazil (Hirth 1971). The waters surrounding the island of Culebra, Puerto Rico, and its outlying keys are designated critical habitat for the green sea turtle.

Age at maturity for green sea turtles is estimated to be 20-50 years (Balazs 1982; Frazer and Ehrhart 1985; Seminoff 2004). As is the case with the other sea turtle species described above, adult females may nest multiple times in a season (average 3 nests/season with approximately 100 eggs/nest) and typically do not nest in successive years (NMFS and USFWS 1991; Hirth 1997).

Population Dynamics and Status

Like other sea turtle species, nest count information for green sea turtles provides information on the relative abundance of nesting, and the contribution of each nesting group to total nesting of the species. Nest counts can also be used to estimate the number of reproductively mature females nesting annually. The 5-year status review for the species identified eight geographic areas considered to be primary sites for threatened green sea turtle nesting in the Atlantic/Caribbean, and reviewed the trend in nest count data for each (NMFS and USFWS 2007d). These include: (1) Yucatán Peninsula, Mexico, (2) Tortuguero, Costa Rica, (3) Aves Island, Venezuela, (4) Galibi Reserve, Suriname, (5) Isla Trindade, Brazil, (6) Ascension Island, United Kingdom, (7) Bioko Island, Equatorial Guinea, and (8) Bijagos Archipelago, Guinea-Bissau (NMFS and USFWS 2007d).

Nesting at all of these sites is considered to be stable or increasing with the exception of Bioko Island, which may be declining. However, the lack of sufficient data precludes a meaningful trend assessment for this site (NMFS and USFWS 2007d).

Seminoff (2004) reviewed green sea turtle nesting data for eight sites in the western, eastern, and central Atlantic, including all of the above threatened nesting sites with the exception that nesting in Florida was reviewed in place of Isla Trindade, Brazil. He concluded that all sites in the central and western Atlantic showed increased nesting with the exception of nesting at Aves Island, Venezuela, while both sites in the eastern Atlantic demonstrated decreased nesting. These sites are not inclusive of all green sea turtle nesting in the Atlantic Ocean. However, other sites are not believed to support nesting levels high enough that would change the overall status of the species in the Atlantic (NMFS and USFWS 2007d).

By far, the most important nesting concentration for green sea turtles in the western Atlantic is in Tortuguero, Costa Rica (NMFS and USFWS 2007d). Nesting in the area has increased considerably since the 1970s and nest count data from 1999-2003 suggest nesting by 17,402-37,290 females per year (NMFS and USFWS 2007d). The number of females nesting per year on beaches in the Yucatán, at Aves Island, Galibi Reserve, and Isla Trindade number in the hundreds to low thousands, depending on the site (NMFS and USFWS 2007d).

The status of the endangered Florida breeding population was also evaluated in the 5-year review (NMFS and USFWS 2007d). The pattern of green sea turtle nesting shows biennial peaks in abundance, with a generally positive trend since establishment of the Florida index beach surveys in 1989. This trend is perhaps due to increased protective legislation throughout the Caribbean (Meylan *et al.* 1995), as well as protections in Florida and throughout the United States (NMFS and USFWS 2007d).

The statewide Florida surveys (2000-2006) have shown that a mean of approximately 5,600 nests are laid annually in Florida, with a low of 581 in 2001 to a high of 9,644 in 2005 (NMFS and USFWS 2007d). Most nesting occurs along the east coast of Florida, but occasional nesting has been documented along the Gulf coast of Florida, at Southwest Florida beaches, as well as the beaches in the Florida Panhandle (Meylan *et al.* 1995). More recently, green sea turtle nesting occurred on Bald Head Island, North Carolina (just east of the mouth of the Cape Fear River), Onslow Island, and Cape Hatteras National Seashore. One green sea turtle nested on a beach in Delaware in 2011, although its occurrence was considered very rare.

Threats

Green sea turtles face many of the same natural threats as loggerhead and Kemp's ridley sea turtles. In addition, green sea turtles appear to be particularly susceptible to fibropapillomatosis, an epizootic disease producing lobe-shaped tumors on the soft portion of a turtle's body. Juveniles appear to be most affected in that they have the highest incidence of disease and the most extensive lesions, whereas lesions in nesting adults are rare. Also, green sea turtles frequenting nearshore waters, areas adjacent to large human populations, and areas with low water turnover, such as lagoons, have a higher incidence of the disease than individuals in deeper, more remote waters. The occurrence of fibropapilloma tumors may result in impaired foraging, breathing, or swimming ability, leading potentially to death (George 1997).

As with the other sea turtle species, incidental fishery mortality accounts for a large proportion of annual human-caused mortality outside the nesting beaches. Witherington *et al.* (2009) observes that because green sea turtles spend a shorter time in oceanic waters and as older juveniles occur on shallow seagrass pastures (where benthic trawling is unlikely), they avoid high mortalities in pelagic longline and benthic trawl fisheries. Although the relatively low number of observed green sea turtle captures makes it difficult to estimate bycatch rates and annual take levels, green sea turtles have been observed captured in the pelagic driftnet, pelagic longline, southeast shrimp trawl, and mid-Atlantic trawl and gillnet fisheries. Murray (2009a) also lists five observed captures of green turtle in Mid-Atlantic sink gillnet gear between 1995 and 2006.

Finkbeiner *et al.* (2011) compiled cumulative sea turtle bycatch information in U.S. fisheries from 1990 through 2007, before and after implementation of bycatch mitigation measures. Information was obtained from peer reviewed publications and NMFS documents (e.g., Biological Opinions and bycatch reports). In the Atlantic, a mean estimate of 137,700 bycatch interactions, of which 4,500 were mortalities, occurred annually (since implementation of bycatch mitigation measures). Kemp's ridleys interacted with fisheries most frequently, with the highest level of mean annual mortality (2,700), followed by loggerheads (1,400), greens (300), and leatherbacks (40). The Southeast/Gulf of Mexico shrimp trawl fishery was responsible for the vast majority of U.S. interactions (up to 98%) and mortalities (more than 80%). While this provides an initial cumulative bycatch assessment, there are a number of caveats that should be considered when interpreting this information, such as sampling inconsistencies and limitations.

Other activities like channel dredging, marine debris, pollution, vessel strikes, power plant impingement, and habitat destruction account for an unquantifiable level of other mortality. Stranding reports indicate that between 200-400 green sea turtles strand annually along the eastern U.S. coast from a variety of causes most of which are unknown (STSSN database).

Summary of Status of Green Sea Turtles

A review of 32 Index Sites² distributed globally revealed a 48-67% decline in the number of mature females nesting annually over the last three generations³ (Seminoff 2004). An evaluation of green sea turtle nesting sites was also conducted as part of the 5-year status review of the species (NMFS and USFWS 2007d). Of the 23 threatened nesting groups assessed in that report for which nesting abundance trends could be determined, ten were considered to be increasing, nine were considered stable, and four were considered to be decreasing (NMFS and USFWS 2007d). Nesting groups were considered to be doing relatively well (the number of sites with increasing nesting were greater than the number of sites with decreasing nesting) in the Pacific, western Atlantic, and central Atlantic (NMFS and USFWS 2007d). However, nesting populations were determined to be doing relatively poorly in Southeast Asia, eastern Indian Ocean, and perhaps the Mediterranean. Overall, based on mean annual reproductive effort, the report estimated that 108,761 to 150,521 females nest each year among the 46 threatened and endangered nesting sites included in the evaluation (NMFS

² The 32 Index Sites include all of the major known nesting areas as well as many of the lesser nesting areas for which quantitative data are available.

³ Generation times ranged from 35.5 years to 49.5 years for the assessment depending on the Index Beach site

and USFWS 2007d). However, given the late age to maturity for green sea turtles, caution is urged regarding the status for any of the nesting groups since no area has a dataset spanning a full green sea turtle generation (NMFS and USFWS 2007d).

Seminoff (2004) and NMFS and USFWS (2007d) made comparable conclusions with regard to nesting for four nesting sites in the western Atlantic that indicate sea turtle abundance is increasing in the Atlantic Ocean. Each also concluded that nesting at Tortuguero, Costa Rica represented the most important nesting area for green sea turtles in the western Atlantic and that nesting had increased markedly since the 1970s (Seminoff 2004; NMFS and USFWS 2007d).

However, the 5-year review also noted that the Tortuguero nesting stock continued to be affected by ongoing directed take at their primary foraging area in Nicaragua (NMFS and USFWS 2007d). The endangered breeding population in Florida appears to be increasing based upon index nesting data from 1989-2010 (NMFS 2011).

As with the other sea turtle species, fishery mortality accounts for a large proportion of annual human-caused mortality outside the nesting beaches, while other activities like hopper dredging, pollution, and habitat destruction account for an unknown level of other mortality. Based on its 5-year status review of the species, NMFS and USFWS (2007d) determined that the listing classification for green sea turtles should not be changed. However, it was also determined that an analysis and review of the species should be conducted in the future to determine whether DPSs should be identified (NMFS and USFWS 2007d).

5.5 Status of Leatherback Sea Turtles

Leatherback sea turtles are widely distributed throughout the oceans of the world, including the Atlantic, Pacific, and Indian Oceans, and the Mediterranean Sea (Ernst and Barbour 1972). Leatherbacks are the largest living turtles and range farther than any other sea turtle species. Their large size and tolerance of relatively low water temperatures allows them to occur in boreal waters such as those off Labrador and in the Barents Sea (NMFS and USFWS 1995).

In 1980, the leatherback population was estimated at approximately 115,000 adult females globally (Pritchard 1982). By 1995, this global population of adult females was estimated to have declined to 34,500 (Spotila *et al.* 1996). The most recent population size estimate for the North Atlantic alone is a range of 34,000-94,000 adult leatherbacks (TEWG 2007). Thus, there is substantial uncertainty with respect to global population estimates of leatherback sea turtles.

Pacific Ocean

Leatherback nesting has been declining at all major Pacific basin nesting beaches for the last two decades (Spotila *et al.* 1996, 2000; NMFS and USFWS 1998a, 2007b; Sarti *et al.* 2000). In the western Pacific, major nesting beaches occur in Papua New Guinea, Indonesia, Solomon Islands, and Vanuatu, with an approximate 2,700-4,500 total breeding females, estimated from nest counts (Dutton *et al.* 2007). While there appears to be overall long term population decline, the Indonesian nesting aggregation at Jamursba-Medi is currently stable (since 1999), although there is evidence to suggest a significant and continued decline in leatherback nesting in Papua New Guinea and Solomon Islands over the past 30 years (NMFS 2011). Leatherback sea turtles disappeared from India before 1930, have been virtually extinct in Sri Lanka since 1994, and appear to be

approaching extinction in Malaysia (Spotila *et al.* 2000). In Fiji, Thailand, and Australia, leatherback sea turtles have only been known to nest in low densities and scattered sites.

The largest, extant leatherback nesting group in the Indo-Pacific lies on the North Vogelkop coast of West Papua, Indonesia, with 3,000-5,000 nests reported annually in the 1990s (Suárez *et al.* 2000). However, in 1999, local villagers started reporting dramatic declines in sea turtles near their villages (Suárez 1999). Declines in nesting groups have been reported throughout the western Pacific region where observers report that nesting groups are well below abundance levels that were observed several decades ago (*e.g.*, Suárez 1999).

Leatherback sea turtles in the western Pacific are threatened by poaching of eggs, killing of nesting females, human encroachment on nesting beaches, incidental capture in fishing gear, beach erosion, and egg predation by animals.

In the eastern Pacific Ocean, major leatherback nesting beaches are located in Mexico and Costa Rica, where nest numbers have been declining. According to reports from the late 1970s and early 1980s, beaches located on the Mexican Pacific coasts of Michoacán, Guerrero, and Oaxaca sustained a large portion, perhaps 50%, of all global nesting by leatherbacks (Sarti *et al.* 1996). A dramatic decline has been seen on nesting beaches in Pacific Mexico, where aerial survey data was used to estimate that tens of thousands of leatherback nests were laid on the beaches in the 1980s (Pritchard 1982), but a total of only 120 nests on the four primary index beaches (combined) were counted in the 2003-2004 season (Sarti Martinez *et al.* 2007). Since the early 1980s, the Mexican Pacific population of adult female leatherback turtles has declined to slightly more than 200 during 1998-1999 and 1999-2000 (Sarti *et al.* 2000). Spotila *et al.* (2000) reported the decline of the leatherback nesting at Playa Grande, Costa Rica, which had been the fourth largest nesting group in the world and the most important nesting beach in the Pacific. Between 1988 and 1999, the nesting group declined from 1,367 to 117 female leatherback sea turtles. Based on their models, Spotila *et al.* (2000) estimated that the group could fall to less than 50 females by 2003-2004. Another, more recent, analysis of the Costa Rican nesting beaches indicates a decline in nesting during 15 years of monitoring (1989-2004) with approximately 1,504 females nesting in 1988-1989 to an average of 188 females nesting in 2000-2001 and 2003-2004 (NMFS and USFWS 2007b), indicating that the reductions in nesting females were not as extreme as the reductions predicted by Spotila *et al.* (2000).

On September 26, 2007, NMFS received a petition to revise the critical habitat designation for leatherback sea turtles to include waters along the U.S. West Coast. On December 28, 2007, NMFS published a positive 90-day finding on the petition and convened a critical habitat review team. On January 26, 2012, NMFS published a final rule to revise the critical habitat designation to include three particular areas of marine habitat. The designation includes approximately 16,910 square miles along the California coast from Point Arena to Point Arguello east of the 3,000 meter depth contour, and 25,004 square miles from Cape Flattery, Washington to Cape Blanco, Oregon east of the 2,000 meter depth contour. The areas comprise approximately 41,914 square miles of marine habitat and include waters from the ocean surface down to a maximum depth of 262 feet. The designated critical habitat areas contain the physical or biological feature essential to the conservation of the species that may require special management conservation or protection. In particular, the team identified one Primary Constituent Element: the occurrence of prey species,

primarily scyphomedusae of the order Semaestomeae, of sufficient condition, distribution, diversity, abundance and density necessary to support individual as well as population growth, reproduction, and development of leatherbacks.

Leatherbacks in the eastern Pacific face a number of threats to their survival. For example, commercial and artisanal swordfish fisheries off Chile, Columbia, Ecuador, and Peru; purse seine fisheries for tuna in the eastern tropical Pacific Ocean; and California/Oregon drift gillnet fisheries are known to capture, injure, or kill leatherbacks in the eastern Pacific Ocean. Given the declines in leatherback nesting in the Pacific, some researchers have concluded that the leatherback is on the verge of extinction in the Pacific Ocean (*e.g.*, Spotila *et al.* 1996, 2000).

Indian Ocean

Leatherbacks nest in several areas around the Indian Ocean. These sites include Tongaland, South Africa (Pritchard 2002) and the Andaman and Nicobar Islands (Andrews *et al.* 2002). Intensive survey and tagging work in 2001 provided new information on the level of nesting in the Andaman and Nicobar Islands (Andrews *et al.* 2002). Based on the survey and tagging work, it was estimated that 400-500 female leatherbacks nest annually on Great Nicobar Island (Andrews *et al.* 2002). The number of nesting females using the Andaman and Nicobar Islands combined was estimated around 1,000 (Andrews and Shanker 2002). Some nesting also occurs along the coast of Sri Lanka, although in much smaller numbers than in the past (Pritchard 2002).

Mediterranean Sea

Casale *et al.* (2003) reviewed the distribution of leatherback sea turtles in the Mediterranean. Among the 411 individual records of leatherback sightings in the Mediterranean, there were no nesting records. Nesting in the Mediterranean is believed to be extremely rare if it occurs at all. Leatherbacks found in Mediterranean waters originate from the Atlantic Ocean (P. Dutton, NMFS, unpublished data).

Atlantic Ocean

Distribution and Life History

Evidence from tag returns and strandings in the western Atlantic suggests that adult leatherback sea turtles engage in routine migrations between northern temperate and tropical waters (NMFS and USFWS 1992). Leatherbacks are frequently thought of as a pelagic species that feed on jellyfish (*e.g.*, *Stomolophus*, *Chrysaora*, and *Aurelia* species) and tunicates (*e.g.*, salps, pyrosomas) (Rebel 1974; Davenport and Balazs 1991). However, leatherbacks are also known to use coastal waters of the U.S. continental shelf (James *et al.* 2005a; Eckert *et al.* 2006; Murphy *et al.* 2006), as well as the European continental shelf on a seasonal basis (Witt *et al.* 2007).

Tagging and satellite telemetry data indicate that leatherbacks from the western North Atlantic nesting beaches use the entire North Atlantic Ocean (TEWG 2007). For example, leatherbacks tagged at nesting beaches in Costa Rica have been found in Texas, Florida, South Carolina, Delaware, and New York (STSSN database). Leatherback sea turtles tagged in Puerto Rico, Trinidad, and the Virgin Islands have also been subsequently found on U.S. beaches of southern, Mid-Atlantic, and northern states (STSSN database). Leatherbacks from the South Atlantic nesting assemblages (West Africa, South Africa, and Brazil) have not been re-sighted in the western North Atlantic (TEWG 2007).

The CETAP aerial survey of the outer Continental Shelf from Cape Hatteras, North Carolina to Cape Sable, Nova Scotia conducted between 1978 and 1982 showed leatherbacks to be present throughout the area with the most numerous sightings made from the Gulf of Maine south to Long Island. Leatherbacks were sighted in water depths ranging from 1 to 4,151 m, but 84.4% of sightings were in waters less than 180 m (Shoop and Kenney 1992). Leatherbacks were sighted in waters within a sea surface temperature range similar to that observed for loggerheads; from 7°-27.2°C (Shoop and Kenney 1992). However, leatherbacks appear to have a greater tolerance for colder waters in comparison to loggerhead sea turtles since more leatherbacks were found at the lower temperatures (Shoop and Kenney 1992). Studies of satellite tagged leatherbacks suggest that they spend 10%-41% of their time at the surface, depending on the phase of their migratory cycle (James *et al.* 2005b). The greatest amount of surface time (up to 41%) was recorded when leatherbacks occurred in continental shelf and slope waters north of 38°N (James *et al.* 2005b).

In 1979, the waters adjacent to Sandy Point, St. Croix, U.S. Virgin Islands were designated as critical habitat for the leatherback sea turtle. On February 2, 2010, NMFS received a petition to revise the critical habitat designation for leatherback sea turtles to include waters adjacent to a major nesting beach in Puerto Rico. NMFS published a 90-day finding on the petition on July 16, 2010, which found that the petition did not present substantial scientific information indicating that the petitioned revision was warranted. The original petitioners submitted a second petition on November 2, 2010 to revise the critical habitat designation to again include waters adjacent to a major nesting beach in Puerto Rico, including additional information on the usage of the waters. NMFS determined on May 5, 2011, that a revision to critical habitat off Puerto Rico may be warranted, and an analysis is underway. Note that on August 4, 2011, FWS issued a determination that revision to critical habitat along Puerto Rico should be made and will be addressed during the future planned status review.

Leatherbacks are a long lived species (>30 years). They were originally believed to mature at a younger age than loggerhead sea turtles, with a previous estimated age at sexual maturity of about 13-14 years for females with 9 years reported as a likely minimum (Zug and Parham 1996) and 19 years as a likely maximum (NMFS SEFSC 2001). However, new sophisticated analyses suggest that leatherbacks in the Northwest Atlantic may reach maturity at 24.5-29 years of age (Avens *et al.* 2009). In the United States and Caribbean, female leatherbacks nest from March through July. In the Atlantic, most nesting females average between 150-160 cm curved carapace length (CCL), although smaller (<145 cm CCL) and larger nesters are observed (Stewart *et al.* 2007, TEWG 2007). They nest frequently (up to seven nests per year) during a nesting season and nest about every 2-3 years. They produce 100 eggs or more in each clutch and can produce 700 eggs or more per nesting season (Schultz 1975). However, a significant portion (up to approximately 30%) of the eggs can be infertile. Therefore, the actual proportion of eggs that can result in hatchlings is less than the total number of eggs produced per season. As is the case with other sea turtle species, leatherback hatchlings enter the water soon after hatching. Based on a review of all sightings of leatherback sea turtles of <145 cm CCL, Eckert (1999) found that leatherback juveniles remain in waters warmer than 26°C until they exceed 100 cm CCL.

Population Dynamics and Status

As described earlier, sea turtle nesting survey data is important in that it provides information on the relative abundance of nesting, and the contribution of each population/subpopulation to total nesting of the species. Nest counts can also be used to estimate the number of reproductively mature females nesting annually, and as an indicator of the trend in the number of nesting females in the nesting group. The 5-year review for leatherback sea turtles (NMFS and USFWS 2007b) compiled the most recent information on mean number of leatherback nests per year for each of the seven leatherback populations or groups of populations that were identified by the Leatherback TEWG as occurring within the Atlantic. These are: Florida, North Caribbean, Western Caribbean, Southern Caribbean, West Africa, South Africa, and Brazil (TEWG 2007).

In the United States, the Florida Statewide Nesting Beach Survey program has documented an increase in leatherback nesting numbers from 98 nests in 1988 to between 800 and 900 nests in the early 2000s (NMFS and USFWS 2007b). Stewart *et al.* (2011) evaluated nest counts from 68 Florida beaches over 30 years (1979-2008) and found that nesting increased at all beaches with trends ranging from 3.1%-16.3% per year, with an overall increase of 10.2% per year. An analysis of Florida's index nesting beach sites from 1989-2006 shows a substantial increase in leatherback nesting in Florida during this time, with an annual growth rate of approximately 1.17 (TEWG 2007). The TEWG reports an increasing or stable nesting trend for all of the seven populations or groups of populations with the exception of the Western Caribbean and West Africa. The leatherback rookery along the northern coast of South America in French Guiana and Suriname supports the majority of leatherback nesting in the western Atlantic (TEWG 2007), and represents more than half of total nesting by leatherback sea turtles worldwide (Hilterman and Goverse 2004). Nest numbers in Suriname have shown an increase and the long-term trend for the Suriname and French Guiana nesting group seems to show an increase (Hilterman and Goverse 2004). In 2001, the number of nests for Suriname and French Guiana combined was 60,000, one of the highest numbers observed for this region in 35 years (Hilterman and Goverse 2004). The TEWG (2007) report indicates that using nest numbers from 1967-2005, a positive population growth rate was found over the 39-year period for French Guinea and Suriname, with a 95% probability that the population was growing. Given the magnitude of leatherback nesting in this area compared to other nest sites, negative impacts in leatherback sea turtles in this area could have profound impacts on the entire species.

The CETAP aerial survey conducted from 1978-1982 estimated the summer leatherback population for the northeastern United States at approximately 300-600 animals (from near Nova Scotia, Canada to Cape Hatteras, North Carolina) (Shoop and Kenney 1992). However, the estimate was based on turtles visible at the surface and does not include those that were below the surface out of view. Therefore, it likely underestimated the leatherback population for the northeastern United States at the time of the survey. Estimates of leatherback abundance of 1,052 turtles (C.V. = 0.38) and 1,174 turtles (C.V. = 0.52) were obtained from surveys conducted from Virginia to the Gulf of St. Lawrence in 1995 and 1998, respectively (Palka 2000). However, since these estimates were also based on sightings of leatherbacks at the surface, the author considered the estimates to be negatively biased and the true abundance of leatherbacks may be 4.27 times higher (Palka 2000).

Threats

The 5-year status review (NMFS and USFWS 2007b) and TEWG (2007) report provide summaries of natural as well as anthropogenic threats to leatherback sea turtles. Of the Atlantic sea turtle

species, leatherbacks seem to be the most vulnerable to entanglement in fishing gear, trap/pot gear in particular. This susceptibility may be the result of their body type (large size, long pectoral flippers, and lack of a hard shell), their diving and foraging behavior, their distributional overlap with the gear, their possible attraction to gelatinous organisms and algae that collect on buoys and buoy lines at or near the surface, and perhaps to the lightsticks used to attract target species in longline fisheries. Leatherbacks entangled in fishing gear generally have a reduced ability to feed, dive, surface to breathe, or perform any other behavior essential to survival (Balazs 1985). In addition to drowning from forced submergence, they may be more susceptible to boat strikes if forced to remain at the surface, and entangling lines can constrict blood flow resulting in tissue necrosis. The long-term impacts of entanglement on leatherback health remain unclear. Innis *et al.* (2010) conducted a health evaluation of leatherback sea turtles during direct capture (n=12) and disentanglement (n=7). They found no significant difference in many of the measured health parameters between entangled and directly captured turtles. However, blood parameters, including but not limited to sodium, chloride, and blood urea nitrogen, for entangled turtles showed several key differences that were most likely due to reduced foraging and associated seawater ingestion, as well as a general stress response.

Finkbeiner *et al.* (2011) compiled cumulative sea turtle bycatch information in U.S. fisheries from 1990 through 2007, before and after implementation of bycatch mitigation measures. Information was obtained from peer reviewed publications and NMFS documents (e.g., Biological Opinions and bycatch reports). In the Atlantic, a mean estimate of 137,700 bycatch interactions, of which 4,500 were mortalities, occurred annually (since implementation of bycatch mitigation measures). Kemp's ridleys interacted with fisheries most frequently, with the highest level of mean annual mortality (2,700), followed by loggerheads (1,400), greens (300), and leatherbacks (40). The Southeast/Gulf of Mexico shrimp trawl fishery was responsible for the vast majority of U.S. interactions (up to 98%) and mortalities (more than 80%). While this provides an initial cumulative bycatch assessment, there are a number of caveats that should be considered when interpreting this information, such as sampling inconsistencies and limitations.

Leatherbacks have been documented interacting with longline, trap/pot, trawl, and gillnet fishing gear. For instance, an estimated 6,363 leatherback sea turtles were documented as caught by the U.S. Atlantic tuna and swordfish longline fisheries between 1992-1999 (NMFS SEFSC 2001). Currently, the U.S. tuna and swordfish longline fisheries managed under the HMS FMP are estimated to capture 1,764 leatherbacks (no more than 252 mortalities) for each 3-year period starting in 2007 (NMFS 2004a). In 2010, there were 26 observed interactions between leatherback sea turtles and longline gear used in the HMS fishery (Garrison and Stokes 2011a, 2011b). All leatherbacks were released alive, with all gear removed for the majority of captures. While 2010 total estimates are not yet available, in 2009, 285.8 (95% CI: 209.6-389.7) leatherback sea turtles are estimated to have been taken in the longline fisheries managed under the HMS FMP based on the observed takes (Garrison and Stokes 2010). The 2009 estimate continues a downward trend since 2007 and remains well below the average prior to implementation of gear regulations (Garrison and Stokes 2010). Since the U.S. fleet accounts for only 5%-8% of the longline hooks fished in the Atlantic Ocean, adding up the under-represented observed takes of the other 23 countries actively fishing in the area would likely result in annual take estimates of thousands of leatherbacks over different life stages (NMFS SEFSC 2001). Lewison *et al.* (2004) estimated that

30,000-60,000 leatherbacks were taken in all Atlantic longline fisheries in 2000 (including the U.S. Atlantic tuna and swordfish longline fisheries, as well as others).

Leatherbacks are susceptible to entanglement in the lines associated with trap/pot gear used in several fisheries. From 1990-2000, 92 entangled leatherbacks were reported from New York through Maine (Dwyer *et al.* 2002). Additional leatherbacks stranded wrapped in line of unknown origin or with evidence of a past entanglement (Dwyer *et al.* 2002). More recently, from 2002 to 2010, NMFS received 137 reports of sea turtles entangled in vertical lines from Maine to Virginia, with 128 events confirmed (verified by photo documentation or response by a trained responder; NMFS 2008a). Of the 128 confirmed events during this period, 117 events involved leatherbacks. NMFS identified the gear type and fishery for 72 of the 117 confirmed events, which included lobster (42⁴), whelk/conch (15), black sea bass (10), crab (2), and research pot gear (1). A review of leatherback mortality documented by the STSSN in Massachusetts suggests that vessel strikes and entanglement in fixed gear (primarily lobster pots and whelk pots) are the principal sources of this mortality (Dwyer *et al.* 2002).

Leatherback interactions with the U.S. South Atlantic and Gulf of Mexico shrimp fisheries are also known to occur (NMFS 2002). Leatherbacks are likely to encounter shrimp trawls working in the coastal waters off the U.S. Atlantic coast (from Cape Canaveral, Florida through North Carolina) as they make their annual spring migration north. For many years, TEDs that were required for use in the U.S. South Atlantic and Gulf of Mexico shrimp fisheries were less effective for leatherbacks as compared to the smaller, hard-shelled turtle species, because the TED openings were too small to allow leatherbacks to escape. To address this problem, NMFS issued a final rule on February 21, 2003, to amend the TED regulations (68 FR 8456, February 21, 2003). Modifications to the design of TEDs are now required in order to exclude leatherbacks as well as large benthic immature and sexually mature loggerhead and green sea turtles. Given those modifications, Epperly *et al.* (2002) anticipated an average of 80 leatherback mortalities a year in shrimp gear interactions, dropping to an estimate of 26 leatherback mortalities in 2009 due to effort reduction in the Southeast shrimp fishery (Memo from Dr. B. Ponwith, SEFSC, to Dr. R. Crabtree, SERO, January 5, 2011).

Other trawl fisheries are also known to interact with leatherback sea turtles although on a much smaller scale. In October 2001, for example, a NMFS fisheries observer documented the take of a leatherback in a bottom otter trawl fishing for *Loligo* squid off of Delaware. TEDs are not currently required in this fishery. In November 2007, fisheries observers reported the capture of a leatherback sea turtle in bottom otter trawl gear fishing for summer flounder.

Gillnet fisheries operating in the waters of the Mid-Atlantic states are also known to capture, injure, and/or kill leatherbacks when these fisheries and leatherbacks co-occur. Data collected by the NEFSC Fisheries Observer Program from 1994-1998 (excluding 1997) indicate that a total of 37 leatherbacks were incidentally captured (16 lethally) in drift gillnets set in offshore waters from Maine to Florida during this period. Observer coverage for this period ranged from 54%-92%. In North Carolina, six additional leatherbacks were reported captured in gillnet sets in the spring (NMFS SEFSC 2001). In addition to these, in September 1995, two dead leatherbacks were removed from an 11-inch (28.2-cm) monofilament shark gillnet set in the nearshore waters off of Cape Hatteras (STSSN unpublished data reported in NMFS SEFSC 2001). Lastly, Murray (2009a)

4 One case involved both lobster and whelk/conch gear.

reports five observed leatherback captures in Mid-Atlantic sink gillnet fisheries between 1994 and 2008.

Fishing gear interactions can occur throughout the range of leatherbacks. Entanglements occur in Canadian waters where Goff and Lien (1988) reported that 14 of 20 leatherbacks encountered off the coast of Newfoundland/Labrador were entangled in fishing gear including salmon net, herring net, gillnet, trawl line, and crab pot line. Leatherbacks are known to drown in fish nets set in coastal waters of Sao Tome, West Africa (Castroviejo *et al.* 1994; Graff 1995). Gillnets are one of the suspected causes for the decline in the leatherback sea turtle population in French Guiana (Chevalier *et al.* 1999), and gillnets targeting green and hawksbill sea turtles in the waters of coastal Nicaragua also incidentally catch leatherback sea turtles (Lagueux *et al.* 1998). Observers on shrimp trawlers operating in the northeastern region of Venezuela documented the capture of six leatherbacks from 13,600 trawls (Marcano and Alio-M. 2000). An estimated 1,000 mature female leatherback sea turtles are caught annually in fishing nets off of Trinidad and Tobago with mortality estimated to be between 50%-95% (Eckert and Lien 1999). Many of the sea turtles do not die as a result of drowning, but rather because the fishermen cut them out of their nets (NMFS SEFSC 2001).

Leatherbacks may be more susceptible to marine debris ingestion than other sea turtle species due to the tendency of floating debris to concentrate in convergence zones that juveniles and adults use for feeding (Shoop and Kenney 1992; Lutcavage *et al.* 1997). Investigations of the necropsy results of leatherback sea turtles revealed that a substantial percentage (34% of the 408 leatherback necropsies' recorded between 1885 and 2007) reported plastic within the turtles' stomach contents, and in some cases (8.7% of those cases in which plastic was reported), blockage of the gut was found in a manner that may have caused the mortality (Mrosovsky *et al.* 2009). An increase in reports of plastic ingestion was evident in leatherback necropsies conducted after the late 1960s (Mrosovsky *et al.* 2009). Along the coast of Peru, intestinal contents of 19 of 140 (13%) leatherback carcasses were found to contain plastic bags and film (Fritts 1982). The presence of plastic debris in the digestive tract suggests that leatherbacks might not be able to distinguish between prey items (*e.g.*, jellyfish) and plastic debris (Mrosovsky 1981). Balazs (1985) speculated that plastic objects may resemble food items by their shape, color, size, or even movements as they drift about, and induce a feeding response in leatherbacks.

Summary of Status for Leatherback Sea Turtles

In the Pacific Ocean, the abundance of leatherback sea turtles on nesting beaches has declined dramatically over the past 10 to 20 years. Nesting groups throughout the eastern and western Pacific Ocean have been reduced to a fraction of their former abundance by the combined effects of human activities that have reduced the number of nesting females and reduced the reproductive success of females that manage to nest (for example, egg poaching) (NMFS and USFWS 2007b). No reliable long term trend data for the Indian Ocean populations are currently available. While leatherbacks are known to occur in the Mediterranean Sea, nesting in this region is not known to occur (NMFS and USFWS 2007b).

Nest counts in many areas of the Atlantic Ocean show increasing trends, including for beaches in Suriname and French Guiana which support the majority of leatherback nesting (NMFS and USFWS 2007b). The species as a whole continues to face numerous threats in nesting and marine

habitats. As with the other sea turtle species, fishery mortality accounts for a large proportion of annual human-caused mortality outside the nesting beaches, while other activities like pollution and habitat destruction account for an unknown level of other mortality. The long term recovery potential of this species may be further threatened by observed low genetic diversity, even in the largest nesting groups like French Guiana and Suriname (NMFS and USFWS 2007b).

Based on its 5-year status review of the species, NMFS and USFWS (2007b) determined that endangered leatherback sea turtles should not be delisted or reclassified. However, it was also determined that an analysis and review of the species should be conducted in the future to determine whether DPSs should be identified (NMFS and USFWS 2007b).

5.6 Status of Atlantic sturgeon

The section below describes the Atlantic sturgeon listing, provides life history information that is relevant to all DPSs of Atlantic sturgeon and then provides information specific to the status of each DPS of Atlantic sturgeon. Below, we also provide a description of which Atlantic sturgeon DPSs likely occur in the action area and provide information on the use of the action area by Atlantic sturgeon.

The Atlantic sturgeon (*Acipenser oxyrinchus oxyrinchus*) is a subspecies of sturgeon distributed along the eastern coast of North America from Hamilton Inlet, Labrador, Canada to Cape Canaveral, Florida, USA (Scott and Scott, 1988; ASSRT, 2007; T. Savoy, CT DEP, pers. comm.). NMFS has delineated U.S. populations of Atlantic sturgeon into five DPSs⁵ (77 FR 5880 and 77 FR 5914). These are: the Gulf of Maine, New York Bight, Chesapeake Bay, Carolina, and South Atlantic DPSs (see Figure 1). The results of genetic studies suggest that natal origin influences the distribution of Atlantic sturgeon in the marine environment (Wirgin and King, 2011). However, genetic data as well as tracking and tagging data demonstrate sturgeon from each DPS and Canada occur throughout the full range of the subspecies. Therefore, sturgeon originating from any of the 5 DPSs can be affected by threats in the marine, estuarine and riverine environment that occur far from natal spawning rivers.

On February 6, 2012, we published notice in the *Federal Register* that we were listing the New York Bight, Chesapeake Bay, Carolina, and South Atlantic DPSs as “endangered,” and the Gulf of Maine DPS as “threatened” (77 FR 5880 and 77 FR 5914). The effective date of the listings was April 6, 2012. The DPSs do not include Atlantic sturgeon that are spawned in Canadian rivers. Therefore, Canadian spawned fish are not included in the listings.

As described below, individuals originating from the five listed DPSs may occur in the action area. Information general to all Atlantic sturgeon as well as information specific to each of the relevant DPSs, is provided below.

⁵ To be considered for listing under the ESA, a group of organisms must constitute a “species.” A “species” is defined in section 3 of the ESA to include “any subspecies of fish or wildlife or plants, and any distinct population segment of any species of vertebrate fish or wildlife which interbreeds when mature.”

Figure 1. Map Depicting the Boundaries of the five Atlantic sturgeon DPSs

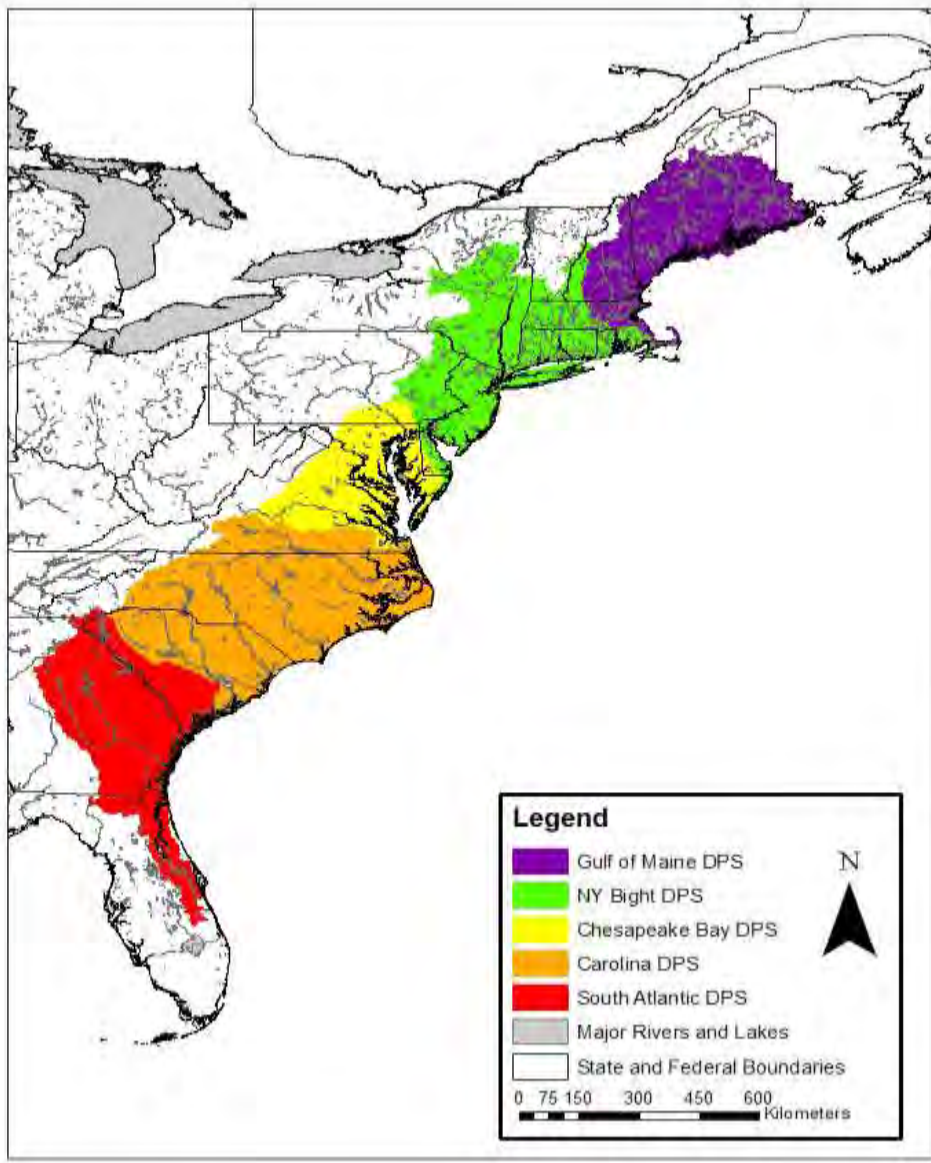

5.6.1 Atlantic sturgeon life history

Atlantic sturgeon are long lived (approximately 60 years), late maturing, estuarine dependent, anadromous⁶ fish (Bigelow and Schroeder, 1953; Vladykov and Greeley 1963; Mangin, 1964; Pikitch *et al.*, 2005; Dadswell, 2006; ASSRT, 2007).

The life history of Atlantic sturgeon can be divided up into five general categories as described in

⁶ Anadromous refers to a fish that is born in freshwater, spends most of its life in the sea, and returns to freshwater to spawn (NEFSC FAQ's, available at <http://www.nefsc.noaa.gov/faq/fishfaq1a.html>, modified June 16, 2011)

the table below (adapted from ASSRT 2012).

Age Class	Size	Description
Egg		Fertilized or unfertilized
Larvae		Negative photo-taxis, nourished by yolk sac
Young of Year (YOY)	0.3 grams <41 cm TL	Fish that are > 3 months and < one year; capable of capturing and consuming live food
Sub-adults	>41 cm and <150 cm TL	Fish that are at least age 1 and are not sexually mature
Adults	>150 cm TL	Sexually mature fish

Table 2. Descriptions of Atlantic sturgeon life history stages.

They are a relatively large fish, even amongst sturgeon species (Pikitch *et al.*, 2005). Atlantic sturgeons are bottom feeders that suck food into a ventrally-located protruding mouth (Bigelow and Schroeder, 1953). Four barbels in front of the mouth assist the sturgeon in locating prey (Bigelow and Schroeder, 1953). Diets of adult and migrant subadult Atlantic sturgeon include mollusks, gastropods, amphipods, annelids, decapods, isopods, and fish such as sand lance (Bigelow and Schroeder, 1953; ASSRT, 2007; Guilbard *et al.*, 2007; Savoy, 2007). While in the river, Atlantic sturgeon feed on aquatic insects, insect larvae, and other invertebrates (Bigelow and Schroeder, 1953; ASSRT, 2007; Guilbard *et al.*, 2007).

Rate of maturation is affected by water temperature and gender. In general: (1) Atlantic sturgeon that originate from southern systems grow faster and mature sooner than Atlantic sturgeon that originate from more northern systems; (2) males grow faster than females; (3) fully mature females attain a larger size (i.e. length) than fully mature males; and (4) the length of Atlantic sturgeon caught since the mid-late 20th century have typically been less than 3 meters (m) (Smith *et al.*, 1982; Smith *et al.*, 1984; Smith, 1985; Scott and Scott, 1988; Young *et al.*, 1998; Collins *et al.*, 2000; Caron *et al.*, 2002; Dadswell, 2006; ASSRT, 2007; Kahnle *et al.*, 2007; DFO, 2011). The largest recorded Atlantic sturgeon was a female captured in 1924 that measured approximately 4.26 m (Vladykov and Greeley, 1963). Dadswell (2006) reported seeing seven fish of comparable size in the St. John River estuary from 1973 to 1995. Observations of large-sized sturgeon are particularly important given that egg production is correlated with age and body size (Smith *et al.*, 1982; Van

Eenennaam *et al.*, 1996; Van Eenennaam and Doroshov, 1998; Dadswell, 2006). However, while females are prolific with egg production ranging from 400,000 to 4 million eggs per spawning year, females spawn at intervals of 2-5 years (Vladykov and Greeley, 1963; Smith *et al.*, 1982; Van Eenennaam *et al.*, 1996; Van Eenennaam and Doroshov, 1998; Stevenson and Secor, 1999; Dadswell, 2006). Given spawning periodicity and a female's relatively late age to maturity, the age at which 50 percent of the maximum lifetime egg production is achieved is estimated to be 29 years (Boreman, 1997). Males exhibit spawning periodicity of 1-5 years (Smith, 1985; Collins *et al.*, 2000; Caron *et al.*, 2002). While long-lived, Atlantic sturgeon are exposed to a multitude of threats prior to achieving maturation and have a limited number of spawning opportunities once mature.

Water temperature plays a primary role in triggering the timing of spawning migrations (ASMFC, 2009). Spawning migrations generally occur during February-March in southern systems, April-May in Mid-Atlantic systems, and May-July in Canadian systems (Murawski and Pacheco, 1977; Smith, 1985; Bain, 1997; Smith and Clugston, 1997; Caron *et al.*, 2002). Male sturgeon begin upstream spawning migrations when waters reach approximately 6° C (43° F) (Smith *et al.*, 1982; Dovel and Berggren, 1983; Smith, 1985; ASMFC, 2009), and remain on the spawning grounds throughout the spawning season (Bain, 1997). Females begin spawning migrations when temperatures are closer to 12° C to 13° C (54° to 55° F) (Dovel and Berggren, 1983; Smith, 1985; Collins *et al.*, 2000), make rapid spawning migrations upstream, and quickly depart following spawning (Bain, 1997).

The spawning areas in most U.S. rivers have not been well defined. However, the habitat characteristics of spawning areas have been identified based on historical accounts of where fisheries occurred, tracking and tagging studies of spawning sturgeon, and physiological needs of early life stages. Spawning is believed to occur in flowing water between the salt front of estuaries and the fall line of large rivers, when and where optimal flows are 46-76 cm/s and depths are 3-27 m (Borodin, 1925; Dees, 1961; Leland, 1968; Scott and Crossman, 1973; Crance, 1987; Shirey *et al.* 1999; Bain *et al.*, 2000; Collins *et al.*, 2000; Caron *et al.* 2002; Hatin *et al.* 2002; ASMFC, 2009). Sturgeon eggs are deposited on hard bottom substrate such as cobble, coarse sand, and bedrock (Dees, 1961; Scott and Crossman, 1973; Gilbert, 1989; Smith and Clugston, 1997; Bain *et al.* 2000; Collins *et al.*, 2000; Caron *et al.*, 2002; Hatin *et al.*, 2002; Mohler, 2003; ASMFC, 2009), and become adhesive shortly after fertilization (Murawski and Pacheco, 1977; Van den Avyle, 1983; Mohler, 2003). Incubation time for the eggs increases as water temperature decreases (Mohler, 2003). At temperatures of 20° and 18° C, hatching occurs approximately 94 and 140 hours, respectively, after egg deposition (ASSRT, 2007).

Larval Atlantic sturgeon (i.e. less than 4 weeks old, with total lengths (TL) less than 30 mm; Van Eenennaam *et al.* 1996) are assumed to undertake a demersal existence and inhabit the same riverine or estuarine areas where they were spawned (Smith *et al.*, 1980; Bain *et al.*, 2000; Kynard and Horgan, 2002; ASMFC, 2009). Studies suggest that age-0 (i.e., young-of-year), age-1, and age-2 Atlantic sturgeon occur in low salinity waters of the natal estuary (Haley, 1999; Hatin *et al.*, 2007; McCord *et al.*, 2007; Munro *et al.*, 2007) while older fish are more salt tolerant and occur in higher salinity waters as well as low salinity waters (Collins *et al.*, 2000). Atlantic sturgeon remain in the natal estuary for months to years before emigrating to open ocean as subadults (Holland and Yelverton, 1973; Dovel and Berggren, 1983; Waldman *et al.*, 1996; Dadswell, 2006; ASSRT, 2007).

After emigration from the natal estuary, subadults and adults travel within the marine environment, typically in waters less than 50 m in depth, using coastal bays, sounds, and ocean waters (Vladykov and Greeley, 1963; Murawski and Pacheco, 1977; Dovel and Berggren, 1983; Smith, 1985; Collins and Smith, 1997; Welsh *et al.*, 2002; Savoy and Pacileo, 2003; Stein *et al.*, 2004; USFWS, 2004; Laney *et al.*, 2007; Dunton *et al.*, 2010; Erickson *et al.*, 2011; Wirgin and King, 2011). Tracking and tagging studies reveal seasonal movements of Atlantic sturgeon along the coast. Satellite-tagged adult sturgeon from the Hudson River concentrated in the southern part of the Mid-Atlantic Bight at depths greater than 20 m during winter and spring, and in the northern portion of the Mid-Atlantic Bight at depths less than 20 m in summer and fall (Erickson *et al.*, 2011). Shirey (Delaware Department of Fish and Wildlife, unpublished data reviewed in ASMFC, 2009) found a similar movement pattern for juvenile Atlantic sturgeon based on recaptures of fish originally tagged in the Delaware River. After leaving the Delaware River estuary during the fall, juvenile Atlantic sturgeon were recaptured by commercial fishermen in nearshore waters along the Atlantic coast as far south as Cape Hatteras, North Carolina from November through early March. In the spring, a portion of the tagged fish re-entered the Delaware River estuary. However, many fish continued a northerly coastal migration through the Mid-Atlantic as well as into southern New England waters where they were recovered throughout the summer months. Movements as far north as Maine were documented. A southerly coastal migration was apparent from tag returns reported in the fall. The majority of these tag returns were reported from relatively shallow near shore fisheries with few fish reported from waters in excess of 25 m (C. Shirey, Delaware Department of Fish and Wildlife, unpublished data reviewed in ASMFC, 2009). Areas where migratory Atlantic sturgeon commonly aggregate include the Bay of Fundy (e.g., Minas and Cumberland Basins), Massachusetts Bay, Connecticut River estuary, Long Island Sound, New York Bight, Delaware Bay, Chesapeake Bay, and waters off of North Carolina from the Virginia/North Carolina border to Cape Hatteras at depths up to 24 m (Dovel and Berggren, 1983; Dadswell *et al.*, 1984; Johnson *et al.*, 1997; Rochard *et al.*, 1997; Kynard *et al.*, 2000; Eyler *et al.*, 2004; Stein *et al.*, 2004; Wehrell, 2005; Dadswell, 2006; ASSRT, 2007; Laney *et al.*, 2007). These sites may be used as foraging sites and/or thermal refuge.

5.6.2 Determination of DPS Composition in the Action Area

As explained above, the range of all five DPSs overlaps and extends from Canada through Cape Canaveral, Florida. The Chesapeake Bay is known to be used by Atlantic sturgeon originating from all five DPSs. We have considered the best available information to determine from which DPSs individuals in the action area are likely to have originated. We have mixed-stock analyses from samples taken in a variety of coastal sampling programs; however, to date, we have no mixed-stock or individual assignment data for Atlantic sturgeon captured in the Chesapeake Bay. We have mixed-stock analysis of Atlantic sturgeon captured in waters off the coast of southern Virginia and North Carolina during the winter months. This area is a known overwintering aggregation; accordingly, we do not expect that the composition of individuals in this area during the winter months is representative of the composition of individuals in the action area year round. Genetic analysis has been completed on 173 samples obtained through NMFS NEFOP program. These fish have been captured in commercial fishing gear from Maine to North Carolina. Because this sampling overlaps with the action area, we consider it to be the best available information from which to determine the DPS composition in the action area. Based on the mixed-stock analysis resulting from genetic assignments of the NEFOP samples, we have determined that Atlantic sturgeon in the action area likely originate from the five DPSs at the following frequencies: NYB

49%; South Atlantic 20%; Chesapeake Bay 14%; Gulf of Maine 11%; and Carolina 4%. Two percent of Atlantic sturgeon in the action area may originate from the St. John's River in Canada; these fish are not included in the 2012 ESA listing. The genetic assignments have a plus/minus 5% confidence interval; however, for purposes of section 7 consultation we have selected the reported values above, which approximate the mid-point of the range, as a reasonable indication of the likely genetic makeup of Atlantic sturgeon in the action area. These assignments and the data from which they are derived are described in detail in Damon-Randall *et al.* (2012a).

5.6.3 Distribution and Abundance

Atlantic sturgeon underwent significant range-wide declines from historical abundance levels due to overfishing in the mid to late 19th century when a caviar market was established (Scott and Crossman, 1973; Taub, 1990; Kennebec River Resource Management Plan, 1993; Smith and Clugston, 1997; Dadswell, 2006; ASSRT, 2007). Abundance of spawning-aged females prior to this period of exploitation was predicted to be greater than 100,000 for the Delaware, and at least 10,000 females for other spawning stocks (Secor and Waldman, 1999; Secor, 2002). Historical records suggest that Atlantic sturgeon spawned in at least 35 rivers prior to this period. Currently, only 16 U.S. rivers are known to support spawning based on available evidence (i.e., presence of young-of-year or gravid Atlantic sturgeon documented within the past 15 years) (ASSRT, 2007). While there may be other rivers supporting spawning for which definitive evidence has not been obtained (e.g., in the Penobscot and York Rivers), the number of rivers supporting spawning of Atlantic sturgeon are approximately half of what they were historically. In addition, only four rivers (Kennebec, Hudson, Delaware, James) are known to currently support spawning from Maine through Virginia where historical records support there used to be fifteen spawning rivers (ASSRT, 2007). Thus, there are substantial gaps in the range between Atlantic sturgeon spawning rivers amongst northern and mid-Atlantic states which could make recolonization of extirpated populations more difficult.

There are no current, published population abundance estimates for any of the currently known spawning stocks. Therefore, there are no published abundance estimates for any of the five DPSs of Atlantic sturgeon. An annual mean estimate of 863 mature adults (596 males and 267 females) was calculated for the Hudson River based on fishery-dependent data collected from 1985-1995 (Kahnle *et al.*, 2007). An estimate of 343 spawning adults per year is available for the Altamaha River, GA, based on fishery-independent data collected in 2004 and 2005 (Schueller and Peterson, 2006). Using the data collected from the Hudson River and Altamaha River to estimate the total number of Atlantic sturgeon in either subpopulation is not possible, since mature Atlantic sturgeon may not spawn every year (Vladykov and Greeley, 1963; Smith, 1985; Van Eenennaam *et al.*, 1996; Stevenson and Secor, 1999; Collins *et al.* 2000; Caron *et al.*, 2002), the age structure of these populations is not well understood, and stage to stage survival is unknown. In other words, the information that would allow us to take an estimate of annual spawning adults and expand that estimate to an estimate of the total number of individuals (e.g., yearlings, subadults, and adults) in a population is lacking. The ASSRT presumed that the Hudson and Altamaha rivers had the most robust of the remaining U.S. Atlantic sturgeon spawning populations and concluded that the other U.S. spawning populations were likely less than 300 spawning adults per year (ASSRT, 2007).

Kahnle *et al.* (2007) estimated the number of total mature adults per year in the Hudson River using

data from surveys in the 1980s to mid-1990s and based on mean harvest by sex divided by sex specific exploitation rate. While this data is over 20 years old, it is currently the best available data on the abundance of Hudson River origin Atlantic sturgeon. The sex ratio of spawners is estimated to be approximately 70% males and 30% females. As noted above, Kahnle *et al.* (2007) estimated a mean annual number of mature adults at 596 males and 267 females. It is important to note that the authors of this paper have stated that this is an estimate of the annual mean number of Hudson River mature adults during the 1985-1995 period, not an estimate of the number of spawners per year.

5.6.4 Threats faced by Atlantic sturgeon throughout their range

Atlantic sturgeon are susceptible to over exploitation given their life history characteristics (e.g., late maturity, dependence on a wide-variety of habitats). Similar to other sturgeon species (Vladykov and Greeley, 1963; Pikitch *et al.*, 2005), Atlantic sturgeon experienced range-wide declines from historical abundance levels due to overfishing (for caviar and meat) and impacts to habitat in the 19th and 20th centuries (Taub, 1990; Smith and Clugston, 1997; Secor and Waldman, 1999).

Based on the best available information, NMFS has concluded that unintended catch of Atlantic sturgeon in fisheries, vessel strikes, poor water quality, water availability, dams, lack of regulatory mechanisms for protecting the fish, and dredging are the most significant threats to Atlantic sturgeon (77 FR 5880 and 77 FR 5914; February 6, 2012). While all of the threats are not necessarily present in the same area at the same time, given that Atlantic sturgeon subadults and adults use ocean waters from the Labrador, Canada to Cape Canaveral, FL, as well as estuaries of large rivers along the U.S. East Coast, activities affecting these water bodies are likely to impact more than one Atlantic sturgeon DPS. In addition, given that Atlantic sturgeon depend on a variety of habitats, every life stage is likely affected by one or more of the identified threats.

An ASMFC interstate fishery management plan for sturgeon (Sturgeon FMP) was developed and implemented in 1990 (Taub, 1990). In 1998, the remaining Atlantic sturgeon fisheries in U.S. state waters were closed per Amendment 1 to the Sturgeon FMP. Complementary regulations were implemented by NMFS in 1999 that prohibit fishing for, harvesting, possessing or retaining Atlantic sturgeon or its parts in or from the Exclusive Economic Zone in the course of a commercial fishing activity.

Commercial fisheries for Atlantic sturgeon still exist in Canadian waters (DFO, 2011). Sturgeon belonging to one or more of the DPSs may be harvested in the Canadian fisheries. In particular, the Bay of Fundy fishery in the Saint John estuary may capture sturgeon of U.S. origin given that sturgeon from the Gulf of Maine and the New York Bight DPSs have been incidentally captured in other Bay of Fundy fisheries (DFO, 2010; Wirgin and King, 2011). Because Atlantic sturgeon are listed under Appendix II of the Convention on International Trade in Endangered Species (CITES), the U.S. and Canada are currently working on a conservation strategy to address the potential for captures of U.S. fish in Canadian directed Atlantic sturgeon fisheries and of Canadian fish incidentally in U.S. commercial fisheries. At this time, there are no estimates of the number of individuals from any of the DPSs that are captured or killed in Canadian fisheries each year.

Based on geographic distribution, most U.S. Atlantic sturgeon that are intercepted in Canadian fisheries are likely to originate from the Gulf of Maine DPS, with a smaller percentage from the

New York Bight DPS.

Fisheries bycatch in U.S. waters is the primary threat faced by all 5 DPSs. At this time, we have an estimate of the number of Atlantic sturgeon captured and killed in sink gillnet and otter trawl fisheries authorized by Federal FMPs (NMFS NEFSC 2011) in the Northeast Region but do not have a similar estimate for Southeast fisheries. We also do not have an estimate of the number of Atlantic sturgeon captured or killed in state fisheries. At this time, we are not able to quantify the effects of other significant threats (e.g., vessel strikes, poor water quality, water availability, dams, and dredging) in terms of habitat impacts or loss of individuals. While we have some information on the number of mortalities that have occurred in the past in association with certain activities (e.g., mortalities in the Delaware and James rivers that are thought to be due to vessel strikes), we are not able to use those numbers to extrapolate effects throughout one or more DPS. This is because of (1) the small number of data points and, (2) lack of information on the percent of incidences that the observed mortalities represent.

As noted above, the NEFSC prepared an estimate of the number of encounters of Atlantic sturgeon in fisheries authorized by Northeast FMPs (NEFSC 2011). The analysis prepared by the NEFSC estimates that from 2006 through 2010 there were 2,250 to 3,862 encounters per year in observed gillnet and trawl fisheries, with an average of 3,118 encounters. Mortality rates in gillnet gear are approximately 20%. Mortality rates in otter trawl gear are believed to be lower at approximately 5%.

5.7 Gulf of Maine DPS of Atlantic sturgeon

The Gulf of Maine DPS includes the following: all anadromous Atlantic sturgeons that are spawned in the watersheds from the Maine/Canadian border and, extending southward, all watersheds draining into the Gulf of Maine as far south as Chatham, MA. Within this range, Atlantic sturgeon historically spawned in the Androscoggin, Kennebec, Merrimack, Penobscot, and Sheepscot Rivers (ASSRT, 2007). Spawning still occurs in the Kennebec and Androscoggin Rivers, and it is possible that it still occurs in the Penobscot River as well. Spawning in the Androscoggin River was just recently confirmed by the Maine Department of Marine Resources when they captured a larval Atlantic sturgeon during the 2011 spawning season below the Brunswick Dam. There is no evidence of recent spawning in the remaining rivers. In the 1800s, construction of the Essex Dam on the Merrimack River at river kilometer (rkm) 49 blocked access to 58 percent of Atlantic sturgeon habitat in the river (Oakley, 2003; ASSRT, 2007). However, the accessible portions of the Merrimack seem to be suitable habitat for Atlantic sturgeon spawning and rearing (i.e., nursery habitat) (Keiffer and Kynard, 1993). Therefore, the availability of spawning habitat does not appear to be the reason for the lack of observed spawning in the Merrimack River. Studies are on-going to determine whether Atlantic sturgeon are spawning in these rivers. Atlantic sturgeons that are spawned elsewhere continue to use habitats within all of these rivers as part of their overall marine range (ASSRT, 2007). The movement of subadult and adult sturgeon between rivers, including to and from the Kennebec River and the Penobscot River, demonstrates that coastal and marine migrations are key elements of Atlantic sturgeon life history for the Gulf of Maine DPS as well as likely throughout the entire range (ASSRT, 2007; Fernandes, *et al.*, 2010).

Bigelow and Schroeder (1953) surmised that Atlantic sturgeon likely spawned in Gulf of Maine Rivers in May-July. More recent captures of Atlantic sturgeon in spawning condition within the Kennebec River suggest that spawning more likely occurs in June-July (Squiers *et al.*, 1981;

ASMFC, 1998; NMFS and USFWS, 1998). Evidence for the timing and location of Atlantic sturgeon spawning in the Kennebec River includes: (1) the capture of five adult male Atlantic sturgeon in spawning condition (i.e., expressing milt) in July 1994 below the (former) Edwards Dam; (2) capture of 31 adult Atlantic sturgeon from June 15, 1980, through July 26, 1980, in a small commercial fishery directed at Atlantic sturgeon from the South Gardiner area (above Merrymeeting Bay) that included at least 4 ripe males and 1 ripe female captured on July 26, 1980; and, (3) capture of nine adults during a gillnet survey conducted from 1977-1981, the majority of which were captured in July in the area from Merrymeeting Bay and upriver as far as Gardiner, ME (NMFS and USFWS, 1998; ASMFC 2007). The low salinity values for waters above Merrymeeting Bay are consistent with values found in other rivers where successful Atlantic sturgeon spawning is known to occur.

Several threats play a role in shaping the current status of Gulf of Maine DPS Atlantic sturgeon. Historical records provide evidence of commercial fisheries for Atlantic sturgeon in the Kennebec and Androscoggin Rivers dating back to the 17th century (Squiers *et al.*, 1979). In 1849, 160 tons of sturgeon was caught in the Kennebec River by local fishermen (Squiers *et al.*, 1979). Following the 1880's, the sturgeon fishery was almost non-existent due to a collapse of the sturgeon stocks. All directed Atlantic sturgeon fishing as well as retention of Atlantic sturgeon by catch has been prohibited since 1998. Nevertheless, mortalities associated with bycatch in fisheries occurring in state and federal waters still occurs. In the marine range, Gulf of Maine DPS Atlantic sturgeon are incidentally captured in federal and state managed fisheries, reducing survivorship of subadult and adult Atlantic sturgeon (Stein *et al.*, 2004; ASMFC 2007). As explained above, we have estimates of the number of subadults and adults that are killed as a result of bycatch in fisheries authorized under Northeast FMPs. At this time, we are not able to quantify the impacts from other threats or estimate the number of individuals killed as a result of other anthropogenic threats. Habitat disturbance and direct mortality from anthropogenic sources are the primary concerns.

Riverine habitat may be impacted by dredging and other in-water activities, disturbing spawning habitat and also altering the benthic forage base. Many rivers in the Gulf of Maine DPS have navigation channels that are maintained by dredging. Dredging outside of Federal channels and in-water construction occurs throughout the Gulf of Maine DPS. While some dredging projects operate with observers present to document fish mortalities, many do not. To date we have not received any reports of Atlantic sturgeon killed during dredging projects in the Gulf of Maine region; however, as noted above, not all projects are monitored for interactions with fish. At this time, we do not have any information to quantify the number of Atlantic sturgeon killed or disturbed during dredging or in-water construction projects are also not able to quantify any effects to habitat.

Connectivity is disrupted by the presence of dams on several rivers in the Gulf of Maine region, including the Penobscot and Merrimack Rivers. While there are also dams on the Kennebec, Androscoggin and Saco Rivers, these dams are near the site of natural falls and likely represent the maximum upstream extent of sturgeon occurrence even if the dams were not present. Because no Atlantic sturgeon are known to occur upstream of any hydroelectric projects in the Gulf of Maine region, passage over hydroelectric dams or through hydroelectric turbines is not a source of injury or mortality in this area. While not expected to be killed or injured during passage at a dam, the extent that Atlantic sturgeon are affected by the existence of dams and their operations in the Gulf

of Maine region is currently unknown. The extent that Atlantic sturgeon are affected by operations of dams in the Gulf of Maine region is currently unknown; however, the documentation of an Atlantic sturgeon larvae downstream of the Brunswick Dam in the Androscoggin River suggests that Atlantic sturgeon spawning may be occurring in the vicinity of at least that project and therefore, may be affected by project operations. The range of Atlantic sturgeon in the Penobscot River is limited by the presence of the Veazie and Great Works Dams. Together these dams prevent Atlantic sturgeon from accessing approximately 29 km of habitat, including the presumed historical spawning habitat located downstream of Milford Falls, the site of the Milford Dam. While removal of the Veazie and Great Works Dams is anticipated to occur in the near future, the presence of these dams is currently preventing access to significant habitats within the Penobscot River. While Atlantic sturgeon are known to occur in the Penobscot River, it is unknown if spawning is currently occurring or whether the presence of the Veazie and Great Works Dams affects the likelihood of spawning occurring in this river. The Essex Dam on the Merrimack River blocks access to approximately 58% of historically accessible habitat in this river. Atlantic sturgeon occur in the Merrimack River but spawning has not been documented. Like the Penobscot, it is unknown how the Essex Dam affects the likelihood of spawning occurring in this river.

Gulf of Maine DPS Atlantic sturgeon may also be affected by degraded water quality. In general, water quality has improved in the Gulf of Maine over the past decades (Lichter *et al.* 2006; EPA, 2008). Many rivers in Maine, including the Androscoggin River, were heavily polluted in the past from industrial discharges from pulp and paper mills. While water quality has improved and most discharges are limited through regulations, many pollutants persist in the benthic environment. This can be particularly problematic if pollutants are present on spawning and nursery grounds as developing eggs and larvae are particularly susceptible to exposure to contaminants.

There are no empirical abundance estimates for the Gulf of Maine DPS. The Atlantic sturgeon SRT (2007) presumed that the Gulf of Maine DPS was comprised of less than 300 spawning adults per year, based on abundance estimates for the Hudson and Altamaha River riverine populations of Atlantic sturgeon. Surveys of the Kennebec River over two time periods, 1977-1981 and 1998-2000, resulted in the capture of nine adult Atlantic sturgeon (Squiers, 2004). However, since the surveys were primarily directed at capture of shortnose sturgeon, the capture gear used may not have been selective for the larger-sized, adult Atlantic sturgeon; several hundred subadult Atlantic sturgeon were caught in the Kennebec River during these studies.

Summary of the Gulf of Maine DPS

Spawning for the Gulf of Maine DPS is known to occur in two rivers (Kennebec and Androscoggin) and possibly in a third. Spawning may be occurring in other rivers, such as the Sheepscot or Penobscot, but has not been confirmed. There are indications of increasing abundance of Atlantic sturgeon belonging to the Gulf of Maine DPS. Atlantic sturgeon continue to be present in the Kennebec River; in addition, they are captured in directed research projects in the Penobscot River, and are observed in rivers where they were unknown to occur or had not been observed to occur for many years (e.g., the Saco, Presumpscot, and Charles rivers). These observations suggest that abundance of the Gulf of Maine DPS of Atlantic sturgeon is sufficient such that recolonization to rivers historically suitable for spawning may be occurring. However, despite some positive signs, there is not enough information to establish a trend for this DPS.

Some of the impacts from the threats that contributed to the decline of the Gulf of Maine DPS have been removed (e.g., directed fishing), or reduced as a result of improvements in water quality and removal of dams (e.g., the Edwards Dam on the Kennebec River in 1999). There are strict regulations on the use of fishing gear in Maine state waters that incidentally catch sturgeon. In addition, there have been reductions in fishing effort in state and federal waters, which most likely would result in a reduction in bycatch mortality of Atlantic sturgeon. A significant amount of fishing in the Gulf of Maine is conducted using trawl gear, which is known to have a much lower mortality rate for Atlantic sturgeon caught in the gear compared to sink gillnet gear (ASMFC, 2007). Atlantic sturgeon from the GOM DPS are not commonly taken as bycatch in areas south of Chatham, MA, with only 8 percent (e.g., 7 of the 84 fish) of interactions observed in the Mid Atlantic/Carolina region being assigned to the Gulf of Maine DPS (Wirgin and King, 2011). Tagging results also indicate that Gulf of Maine DPS fish tend to remain within the waters of the Gulf of Maine and only occasionally venture to points south. However, data on Atlantic sturgeon incidentally caught in trawls and intertidal fish weirs fished in the Minas Basin area of the Bay of Fundy, (Canada) indicate that approximately 35 percent originated from the Gulf of Maine DPS (Wirgin *et al.*, in draft).

As noted previously, studies have shown that in order to rebuild, Atlantic sturgeon can only sustain low levels of bycatch and other anthropogenic mortality (Boreman, 1997; ASMFC, 2007; Kahnle *et al.*, 2007; Brown and Murphy, 2010). NMFS has determined that the Gulf of Maine DPS is at risk of becoming endangered in the foreseeable future throughout all of its range (i.e., is a threatened species) based on the following: (1) significant declines in population sizes and the protracted period during which sturgeon populations have been depressed; (2) the limited amount of current spawning; and, (3) the impacts and threats that have and will continue to affect recovery.

5.8 New York Bight DPS of Atlantic sturgeon

The New York Bight DPS includes the following: all anadromous Atlantic sturgeon spawned in the watersheds that drain into coastal waters from Chatham, MA to the Delaware-Maryland border on Fenwick Island. Within this range, Atlantic sturgeon historically spawned in the Connecticut, Delaware, Hudson, and Taunton Rivers (Murawski and Pacheco, 1977; Secor, 2002; ASSRT, 2007). Spawning still occurs in the Delaware and Hudson Rivers, but there is no recent evidence (within the last 15 years) of spawning in the Connecticut and Taunton Rivers (ASSRT, 2007). Atlantic sturgeon that are spawned elsewhere continue to use habitats within the Connecticut and Taunton Rivers as part of their overall marine range (ASSRT, 2007; Savoy, 2007; Wirgin and King, 2011).

The abundance of the Hudson River Atlantic sturgeon riverine population prior to the onset of expanded exploitation in the 1800's is unknown but, has been conservatively estimated at 10,000 adult females (Secor, 2002). Current abundance is likely at least one order of magnitude smaller than historical levels (Secor, 2002; ASSRT, 2007; Kahnle *et al.*, 2007). As described above, an estimate of the mean annual number of mature adults (863 total; 596 males and 267 females) was calculated for the Hudson River riverine population based on fishery-dependent data collected from 1985-1995 (Kahnle *et al.*, 2007). Kahnle *et al.* (1998; 2007) also showed that the level of fishing mortality from the Hudson River Atlantic sturgeon fishery during the period of 1985-1995 exceeded the estimated sustainable level of fishing mortality for the riverine population and may have led to reduced recruitment. All available data on abundance of juvenile Atlantic sturgeon in the Hudson

River Estuary indicate a substantial drop in production of young since the mid 1970's (Kahnle *et al.*, 1998). A decline appeared to occur in the mid to late 1970's followed by a secondary drop in the late 1980's (Kahnle *et al.*, 1998; Sweka *et al.*, 2007; ASMFC, 2010). Catch-per-unit-effort data suggests that recruitment has remained depressed relative to catches of juvenile Atlantic sturgeon in the estuary during the mid-late 1980's (Sweka *et al.*, 2007; ASMFC, 2010). In examining the CPUE data from 1985-2007, there are significant fluctuations during this time. There appears to be a decline in the number of juveniles between the late 1980s and early 1990s and while the CPUE is generally higher in the 2000s as compared to the 1990s, given the significant annual fluctuation it is difficult to discern any trend. Despite the CPUEs from 2000-2007 being generally higher than those from 1990-1999, they are low compared to the late 1980s. There is currently not enough information regarding any life stage to establish a trend for the Hudson River population.

There is no abundance estimate for the Delaware River population of Atlantic sturgeon. Harvest records from the 1800's indicate that this was historically a large population with an estimated 180,000 adult females prior to 1890 (Secor and Waldman, 1999; Secor, 2002). Sampling in 2009 to target young-of-the-year (YOY) Atlantic sturgeon in the Delaware River (i.e., natal sturgeon) resulted in the capture of 34 YOY, ranging in size from 178 to 349 mm TL (Fisher, 2009) and the collection of 32 YOY Atlantic sturgeon in a separate study (Brundage and O'Herron in Calvo *et al.*, 2010). Genetics information collected from 33 of the 2009 year class YOY indicates that at least 3 females successfully contributed to the 2009 year class (Fisher, 2011). Therefore, while the capture of YOY in 2009 provides evidence that successful spawning is still occurring in the Delaware River, the relatively low numbers suggest the existing riverine population is limited in size.

Several threats play a role in shaping the current status and trends observed in the Delaware River and Estuary. In-river threats include habitat disturbance from dredging, and impacts from historical pollution and impaired water quality. A dredged navigation channel extends from Trenton seaward through the tidal river (Brundage and O'Herron, 2009), and the river receives significant shipping traffic. Vessel strikes have been identified as a threat in the Delaware River; however, at this time we do not have information to quantify this threat or its impact to the population or the New York Bight DPS. Similar to the Hudson River, there is currently not enough information to determine a trend for the Delaware River population.

Summary of the New York Bight DPS

Atlantic sturgeon originating from the New York Bight DPS spawn in the Hudson and Delaware rivers. While genetic testing can differentiate between individuals originating from the Hudson or Delaware river the available information suggests that the straying rate is high between these rivers. There are no indications of increasing abundance for the New York Bight DPS (ASSRT, 2009; 2010). Some of the impact from the threats that contributed to the decline of the New York Bight DPS have been removed (e.g., directed fishing) or reduced as a result of improvements in water quality since passage of the Clean Water Act (CWA). In addition, there have been reductions in fishing effort in state and federal waters, which may result in a reduction in bycatch mortality of Atlantic sturgeon. Nevertheless, areas with persistent, degraded water quality, habitat impacts from dredging, continued bycatch in state and federally-managed fisheries, and vessel strikes remain significant threats to the New York Bight DPS.

In the marine range, New York Bight DPS Atlantic sturgeon are incidentally captured in federal and

state managed fisheries, reducing survivorship of subadult and adult Atlantic sturgeon (Stein *et al.*, 2004; ASMFC 2007). As explained above, currently available estimates indicate that at least 4% of adults may be killed as a result of bycatch in fisheries authorized under Northeast FMPs. Based on mixed stock analysis results presented by Wirgin and King (2011), over 40 percent of the Atlantic sturgeon bycatch interactions in the Mid Atlantic Bight region were sturgeon from the New York Bight DPS. Individual-based assignment and mixed stock analysis of samples collected from sturgeon captured in Canadian fisheries in the Bay of Fundy indicated that approximately 1-2% were from the New York Bight DPS. At this time, we are not able to quantify the impacts from other threats or estimate the number of individuals killed as a result of other anthropogenic threats.

Riverine habitat may be impacted by dredging and other in-water activities, disturbing spawning habitat and also altering the benthic forage base. Both the Hudson and Delaware rivers have navigation channels that are maintained by dredging. Dredging is also used to maintain channels in the nearshore marine environment. Dredging outside of Federal channels and in-water construction occurs throughout the New York Bight region. While some dredging projects operate with observers present to document fish mortalities many do not. We have reports of one Atlantic sturgeon entrained during hopper dredging operations in Ambrose Channel, New Jersey. At this time, we do not have any information to quantify the number of Atlantic sturgeon killed or disturbed during dredging or in-water construction projects are also not able to quantify any effects to habitat.

In the Hudson and Delaware Rivers, dams do not block access to historical habitat. The Holyoke Dam on the Connecticut River blocks further upstream passage; however, the extent that Atlantic sturgeon would historically have used habitat upstream of Holyoke is unknown. Connectivity may be disrupted by the presence of dams on several smaller rivers in the New York Bight region. Because no Atlantic sturgeon occur upstream of any hydroelectric projects in the New York Bight region, passage over hydroelectric dams or through hydroelectric turbines is not a source of injury or mortality in this area. The extent that Atlantic sturgeon are affected by operations of dams in the New York Bight region is currently unknown.

New York Bight DPS Atlantic sturgeon may also be affected by degraded water quality. In general, water quality has improved in the Hudson and Delaware over the past decades (Lichter *et al.* 2006; EPA, 2008). Both the Hudson and Delaware rivers, as well as other rivers in the New York Bight region, were heavily polluted in the past from industrial and sanitary sewer discharges. While water quality has improved and most discharges are limited through regulations, many pollutants persist in the benthic environment. This can be particularly problematic if pollutants are present on spawning and nursery grounds as developing eggs and larvae are particularly susceptible to exposure to contaminants.

Vessel strikes occur in the Delaware River. Twenty-nine mortalities believed to be the result of vessel strikes were documented in the Delaware River from 2004 to 2008, and at least 13 of these fish were large adults. Given the time of year in which the fish were observed (predominantly May through July, with two in August), it is likely that many of the adults were migrating through the river to the spawning grounds. Because we do not know the percent of total vessel strikes that the observed mortalities represent, we are not able to quantify the number of individuals likely killed as a result of vessel strikes in the New York Bight DPS.

Studies have shown that to rebuild, Atlantic sturgeon can only sustain low levels of anthropogenic mortality (Boreman, 1997; ASMFC, 2007; Kahnle *et al.*, 2007; Brown and Murphy, 2010). There are no empirical abundance estimates of the number of Atlantic sturgeon in the New York Bight DPS. As described in the final listing rule, NMFS has determined that the New York Bight DPS is currently at risk of extinction due to: (1) precipitous declines in population sizes and the protracted period in which sturgeon populations have been depressed; (2) the limited amount of current spawning; and (3) the impacts and threats that have and will continue to affect population recovery.

5.9 Chesapeake Bay DPS of Atlantic sturgeon

The Chesapeake Bay DPS includes the following: all anadromous Atlantic sturgeons that are spawned in the watersheds that drain into the Chesapeake Bay and into coastal waters from the Delaware-Maryland border on Fenwick Island to Cape Henry, VA. Within this range, Atlantic sturgeon historically spawned in the Susquehanna, Potomac, James, York, Rappahannock, and Nottoway Rivers (ASSRT, 2007). Based on the review by Oakley (2003), 100 percent of Atlantic sturgeon habitat is currently accessible in these rivers since most of the barriers to passage (i.e. dams) are located upriver of where spawning is expected to have historically occurred (ASSRT, 2007). Spawning still occurs in the James River, and the presence of juvenile and adult sturgeon in the York River suggests that spawning may occur there as well (Musick *et al.*, 1994; ASSRT, 2007; Greene, 2009). However, conclusive evidence of current spawning is only available for the James River. Atlantic sturgeon that are spawned elsewhere are known to use the Chesapeake Bay for other life functions, such as foraging and as juvenile nursery habitat prior to entering the marine system as subadults (Vladykov and Greeley, 1963; ASSRT, 2007; Wirgin *et al.*, 2007; Grunwald *et al.*, 2008).

Age to maturity for Chesapeake Bay DPS Atlantic sturgeon is unknown. However, Atlantic sturgeon riverine populations exhibit clinal variation with faster growth and earlier age to maturity for those that originate from southern waters, and slower growth and later age to maturity for those that originate from northern waters (75 FR 61872; October 6, 2010). Age at maturity is 5 to 19 years for Atlantic sturgeon originating from South Carolina rivers (Smith *et al.*, 1982) and 11 to 21 years for Atlantic sturgeon originating from the Hudson River (Young *et al.*, 1998). Therefore, age at maturity for Atlantic sturgeon of the Chesapeake Bay DPS likely falls within these values.

Several threats play a role in shaping the current status of Chesapeake Bay DPS Atlantic sturgeon. Historical records provide evidence of the large-scale commercial exploitation of Atlantic sturgeon from the James River and Chesapeake Bay in the 19th century (Hildebrand and Schroeder, 1928; Vladykov and Greeley, 1963; ASMFC, 1998; Secor, 2002; Bushnoe *et al.*, 2005; ASSRT, 2007) as well as subsistence fishing and attempts at commercial fisheries as early as the 17th century (Secor, 2002; Bushnoe *et al.*, 2005; ASSRT, 2007; Balazik *et al.*, 2010). Habitat disturbance caused by in-river work such as dredging for navigational purposes is thought to have reduced available spawning habitat in the James River (Holton and Walsh, 1995; Bushnoe *et al.*, 2005; ASSRT, 2007). At this time, we do not have information to quantify this loss of spawning habitat.

Decreased water quality also threatens Atlantic sturgeon of the Chesapeake Bay DPS, especially since the Chesapeake Bay system is vulnerable to the effects of nutrient enrichment due to a relatively low tidal exchange and flushing rate, large surface to volume ratio, and strong stratification during the spring and summer months (Pyzik *et al.*, 2004; ASMFC, 1998; ASSRT,

2007; EPA, 2008). These conditions contribute to reductions in dissolved oxygen levels throughout the Bay. The availability of nursery habitat, in particular, may be limited given the recurrent hypoxia (low dissolved oxygen) conditions within the Bay (Niklitschek and Secor, 2005; 2010). At this time we do not have sufficient information to quantify the extent that degraded water quality effects habitat or individuals in the James River or throughout the Chesapeake Bay.

Vessel strikes have been observed in the James River (ASSRT, 2007). Eleven Atlantic sturgeon were reported to have been struck by vessels from 2005 through 2007. Several of these were mature individuals. Because we do not know the percent of total vessel strikes that the observed mortalities represent, we are not able to quantify the number of individuals likely killed as a result of vessel strikes in the New York Bight DPS.

In the marine and coastal range of the Chesapeake Bay DPS from Canada to Florida, fisheries bycatch in federally and state managed fisheries poses a threat to the DPS, reducing survivorship of subadults and adults and potentially causing an overall reduction in the spawning population (Stein *et al.*, 2004; ASMFC, 2007; ASSRT, 2007).

Summary of the Chesapeake Bay DPS

Spawning for the Chesapeake Bay DPS is known to occur in only the James River. Spawning may be occurring in other rivers, such as the York, but has not been confirmed. There are anecdotal reports of increased sightings and captures of Atlantic sturgeon in the James River. However, this information has not been comprehensive enough to develop a population estimate for the James River or to provide sufficient evidence to confirm increased abundance. Some of the impact from the threats that facilitated the decline of the Chesapeake Bay DPS have been removed (e.g., directed fishing) or reduced as a result of improvements in water quality since passage of the Clean Water Act (CWA). We do not currently have enough information about any life stage to establish a trend for this DPS.

Areas with persistent, degraded water quality, habitat impacts from dredging, continued bycatch in U.S. state and federally-managed fisheries, Canadian fisheries and vessel strikes remain significant threats to the Chesapeake Bay DPS of Atlantic sturgeon. Studies have shown that Atlantic sturgeon can only sustain low levels of bycatch mortality (Boreman, 1997; ASMFC, 2007; Kahnle *et al.*, 2007). The Chesapeake Bay DPS is currently at risk of extinction given (1) precipitous declines in population sizes and the protracted period in which sturgeon populations have been depressed; (2) the limited amount of current spawning; and, (3) the impacts and threats that have and will continue to affect the potential for population recovery.

5.10 Carolina DPS of Atlantic sturgeon

The Carolina DPS includes all Atlantic sturgeon that spawn or are spawned in the watersheds (including all rivers and tributaries) from Albemarle Sound southward along the southern Virginia, North Carolina, and South Carolina coastal areas to Charleston Harbor. The marine range of Atlantic sturgeon from the Carolina DPS extends from the Hamilton Inlet, Labrador, Canada, to Cape Canaveral, Florida. Sturgeon are commonly captured 40 miles offshore (D. Fox, DSU, pers. comm.). Records providing fishery bycatch data by depth show the vast majority of Atlantic sturgeon bycatch via gillnets is observed in waters less than 50 meters deep (Stein *et al.* 2004, ASMFC 2007), but Atlantic sturgeon are recorded as bycatch out to 500 fathoms.

Rivers known to have current spawning populations within the range of the Carolina DPS include the Roanoke, Tar-Pamlico, Cape Fear, Waccamaw, and Pee Dee Rivers. We determined spawning was occurring if young-of-the-year (YOY) were observed, or mature adults were present, in freshwater portions of a system (Table 3). However, in some rivers, spawning by Atlantic sturgeon may not be contributing to population growth because of lack of suitable habitat and the presence of other stressors on juvenile survival and development. There may also be spawning populations in the Neuse, Santee and Cooper Rivers, though it is uncertain. Historically, both the Sampit and Ashley Rivers were documented to have spawning populations at one time. However, the spawning population in the Sampit River is believed to be extirpated and the current status of the spawning population in the Ashley River is unknown. Both rivers may be used as nursery habitat by young Atlantic sturgeon originating from other spawning populations. This represents our current knowledge of the river systems utilized by the Carolina DPS for specific life functions, such as spawning, nursery habitat, and foraging. However, fish from the Carolina DPS likely use other river systems than those listed here for their specific life functions.

River/Estuary	Spawning Population	Data
Roanoke River, VA/NC; Albemarle Sound, NC	Yes	collection of 15 YOY (1997-1998); single YOY (2005)
Tar-Pamlico River, NC; Pamlico Sound	Yes	one YOY (2005)
Neuse River, NC; Pamlico Sound	Unknown	
Cape Fear River, NC	Yes	upstream migration of adults in the fall, carcass of a ripe female upstream in mid-September (2006)
Waccamaw River, SC; Winyah Bay	Yes	age-1, potentially YOY (1980s)
Pee Dee River, SC; Winyah Bay	Yes	running ripe male in Great Pee Dee River (2003)
Sampit, SC; Winyah Bay	Extirpated	
Santee River, SC	Unknown	
Cooper River, SC	Unknown	
Ashley River, SC	Unknown	

Table 3. Major rivers, tributaries, and sounds within the range of the Carolina DPS and currently available data on the presence of an Atlantic sturgeon spawning population in each system.

The riverine spawning habitat of the Carolina DPS occurs within the Mid-Atlantic Coastal Plain ecoregion (TNC 2002a), which includes bottomland hardwood forests, swamps, and some of the world’s most active coastal dunes, sounds, and estuaries. Natural fires, floods, and storms are so dominant in this region that the landscape changes very quickly. Rivers routinely change their courses and emerge from their banks. The primary threats to biological diversity in the Mid-Atlantic Coastal Plain, as listed by TNC are: global climate change and rising sea level; altered

surface hydrology and landform alteration (e.g., flood-control and hydroelectric dams, inter-basin transfers of water, drainage ditches, breached levees, artificial levees, dredged inlets and river channels, beach renourishment, and spoil deposition banks and piles); a regionally receding water table, probably resulting from both over-use and inadequate recharge; fire suppression; land fragmentation, mainly by highway development; land-use conversion (e.g., from forests to timber plantations, farms, golf courses, housing developments, and resorts); the invasion of exotic plants and animals; air and water pollution, mainly from agricultural activities including concentrated animal feed operations; and over-harvesting and poaching of species. Many of the Carolina DPS' spawning rivers, located in the Mid-Coastal Plain, originate in areas of marl. Waters draining calcareous, impervious surface materials such as marl are: (1) likely to be alkaline; (2) dominated by surface run-off; (3) have little groundwater connection; and, (4) are seasonally ephemeral.

Historical landings data indicate that between 7,000 and 10,500 adult female Atlantic sturgeon were present in North Carolina prior to 1890 (Armstrong and Hightower 2002, Secor 2002). Secor (2002) estimates that 8,000 adult females were present in South Carolina during that same time-frame. Reductions from the commercial fishery and ongoing threats have drastically reduced the numbers of Atlantic sturgeon within the Carolina DPS. Currently, the Atlantic sturgeon spawning population in at least one river system within the Carolina DPS has been extirpated, with a potential extirpation in an additional system. The abundances of the remaining river populations within the DPS, each estimated to have fewer than 300 spawning adults, is estimated to be less than 3 percent of what they were historically (ASSRT 2007).

Threats

The Carolina DPS was listed as endangered under the ESA as a result of a combination of habitat curtailment and modification, overutilization (i.e., being taken as bycatch) in commercial fisheries, and the inadequacy of regulatory mechanisms in ameliorating these impacts and threats.

The modification and curtailment of Atlantic sturgeon habitat resulting from dams, dredging, and degraded water quality is contributing to the status of the Carolina DPS. Dams have curtailed Atlantic sturgeon spawning and juvenile developmental habitat by blocking over 60 percent of the historical sturgeon habitat upstream of the dams in the Cape Fear and Santee-Cooper River systems. Water quality (velocity, temperature, and dissolved oxygen (DO)) downstream of these dams, as well as on the Roanoke River, has been reduced, which modifies and curtails the extent of spawning and nursery habitat for the Carolina DPS. Dredging in spawning and nursery grounds modifies the quality of the habitat and is further curtailing the extent of available habitat in the Cape Fear and Cooper Rivers, where Atlantic sturgeon habitat has already been modified and curtailed by the presence of dams. Reductions in water quality from terrestrial activities have modified habitat utilized by the Carolina DPS. In the Pamlico and Neuse systems, nutrient-loading and seasonal anoxia are occurring, associated in part with concentrated animal feeding operations (CAFOs). Heavy industrial development and CAFOs have degraded water quality in the Cape Fear River. Water quality in the Waccamaw and Pee Dee rivers have been affected by industrialization and riverine sediment samples contain high levels of various toxins, including dioxins. Additional stressors arising from water allocation and climate change threaten to exacerbate water quality problems that are already present throughout the range of the Carolina DPS. Twenty interbasin water transfers in existence prior to 1993, averaging 66.5 million gallons per day (mgd), were authorized at their maximum levels without being subjected to an evaluation for certification by

North Carolina Department of Environmental and Natural Resources or other resource agencies. Since the 1993 legislation requiring certificates for transfers, almost 170 mgd of interbasin water withdrawals have been authorized, with an additional 60 mgd pending certification. The removal of large amounts of water from the system will alter flows, temperature, and DO. Existing water allocation issues will likely be compounded by population growth and potentially climate change. Climate change is also predicted to elevate water temperatures and exacerbate nutrient-loading, pollution inputs, and lower DO, all of which are current stressors to the Carolina DPS.

Overutilization of Atlantic sturgeon from directed fishing caused initial severe declines in Atlantic sturgeon populations in the Southeast, from which they have never rebounded. Further, continued overutilization of Atlantic sturgeon as bycatch in commercial fisheries is an ongoing impact to the Carolina DPS. Little data exists on bycatch in the Southeast and high levels of bycatch underreporting are suspected. Further, a total population abundance for the DPS is not available, and it is therefore not possible to calculate the percentage of the DPS subject to bycatch mortality based on the available bycatch mortality rates for individual fisheries. However, fisheries known to incidentally catch Atlantic sturgeon occur throughout the marine range of the species and in some riverine waters as well. Because Atlantic sturgeon mix extensively in marine waters and may access multiple river systems, they are subject to being caught in multiple fisheries throughout their range. In addition, stress or injury to Atlantic sturgeon taken as bycatch but released alive may result in increased susceptibility to other threats, such as poor water quality (e.g., exposure to toxins and low DO). This may result in reduced ability to perform major life functions, such as foraging and spawning, or even post-capture mortality.

As a wide-ranging anadromous species, Carolina DPS Atlantic sturgeon are subject to numerous Federal (U.S. and Canadian), state and provincial, and inter-jurisdictional laws, regulations, and agency activities. While these mechanisms have addressed impacts to Atlantic sturgeon through directed fisheries, there are currently no mechanisms in place to address the significant risk posed to Atlantic sturgeon from commercial bycatch. Though statutory and regulatory mechanisms exist that authorize reducing the impact of dams on riverine and anadromous species, such as Atlantic sturgeon, and their habitat, these mechanisms have proven inadequate for preventing dams from blocking access to habitat upstream and degrading habitat downstream. Further, water quality continues to be a problem in the Carolina DPS, even with existing controls on some pollution sources. Current regulatory regimes are not necessarily effective in controlling water allocation issues (e.g., no restrictions on interbasin water transfers in South Carolina, the lack of ability to regulate non-point source pollution, etc.)

The recovery of Atlantic sturgeon along the Atlantic Coast, especially in areas where habitat is limited and water quality is severely degraded, will require improvements in the following areas: (1) elimination of barriers to spawning habitat either through dam removal, breaching, or installation of successful fish passage facilities; (2) operation of water control structures to provide appropriate flows, especially during spawning season; (3) imposition of dredging restrictions including seasonal moratoriums and avoidance of spawning/nursery habitat; and, (4) mitigation of water quality parameters that are restricting sturgeon use of a river (i.e., DO). Additional data regarding sturgeon use of riverine and estuarine environments is needed.

The concept of a viable population able to adapt to changing environmental conditions is critical to Atlantic sturgeon, and the low population numbers of every river population in the Carolina DPS put them in danger of extinction throughout their range; none of the populations are large or stable enough to provide with any level of certainty for continued existence of Atlantic sturgeon in this part of its range. Although the largest impact that caused the precipitous decline of the species has been curtailed (directed fishing), the population sizes within the Carolina DPS have remained relatively constant at greatly reduced levels (approximately 3 percent of historical population sizes) for 100 years. Small numbers of individuals resulting from drastic reductions in populations, such as occurred with Atlantic sturgeon due to the commercial fishery, can remove the buffer against natural demographic and environmental variability provided by large populations (Berry, 1971; Shaffer, 1981; Soulé, 1980). Recovery of depleted populations is an inherently slow process for a late-maturing species such as Atlantic sturgeon, and they continue to face a variety of other threats that contribute to their risk of extinction. Their late age at maturity provides more opportunities for individual Atlantic sturgeon to be removed from the population before reproducing. While a long life-span also allows multiple opportunities to contribute to future generations, it also results in increases the timeframe over which exposure to the multitude of threats facing the Carolina DPS can occur.

The viability of the Carolina DPS depends on having multiple self-sustaining riverine spawning populations and maintaining suitable habitat to support the various life functions (spawning, feeding, growth) of Atlantic sturgeon populations. Because a DPS is a group of populations, the stability, viability, and persistence of individual populations affects the persistence and viability of the larger DPS. The loss of any population within a DPS will result in: (1) a long-term gap in the range of the DPS that is unlikely to be recolonized; (2) loss of reproducing individuals; (3) loss of genetic biodiversity; (4) potential loss of unique haplotypes; (5) potential loss of adaptive traits; and (6) reduction in total number. The loss of a population will negatively impact the persistence and viability of the DPS as a whole, as fewer than two individuals per generation spawn outside their natal rivers (Secor and Waldman 1999). The persistence of individual populations, and in turn the DPS, depends on successful spawning and rearing within the freshwater habitat, the immigration into marine habitats to grow, and then the return of adults to natal rivers to spawn.

Summary of the Status of the Carolina DPS of Atlantic Sturgeon

In summary, the Carolina DPS is estimated to number less than 3 percent of its historic population size. There are estimated to be less than 300 spawning adults per year (total of both sexes) in each of the major river systems occupied by the DPS in which spawning still occurs, whose freshwater range occurs in the watersheds (including all rivers and tributaries) from Albemarle Sound southward along the southern Virginia, North Carolina, and South Carolina coastal areas to Charleston Harbor. Recovery of depleted populations is an inherently slow process for a late-maturing species such as Atlantic sturgeon. Their late age at maturity provides more opportunities for individuals to be removed from the population before reproducing. While a long life-span also allows multiple opportunities to contribute to future generations, this is hampered within the Carolina DPS by habitat alteration and bycatch. This DPS was severely depleted by past directed commercial fishing, and faces ongoing impacts and threats from habitat alteration or inaccessibility, bycatch, and the inadequacy of existing regulatory mechanisms to address and reduce habitat alterations and bycatch that have prevented river populations from rebounding and will prevent their recovery.

The presence of dams has resulted in the loss of over 60 percent of the historical sturgeon habitat on the Cape Fear River and in the Santee-Cooper system. Dams are contributing to the status of the Carolina DPS by curtailing the extent of available spawning habitat and further modifying the remaining habitat downstream by affecting water quality parameters (such as depth, temperature, velocity, and DO) that are important to sturgeon. Dredging is also contributing to the status of the Carolina DPS by modifying Atlantic sturgeon spawning and nursery habitat. Habitat modifications through reductions in water quality are contributing to the status of the Carolina DPS due to nutrient-loading, seasonal anoxia, and contaminated sediments. Interbasin water transfers and climate change threaten to exacerbate existing water quality issues. Bycatch is also a current threat to the Carolina DPS that is contributing to its status. Fisheries known to incidentally catch Atlantic sturgeon occur throughout the marine range of the species and in some riverine waters as well. Because Atlantic sturgeon mix extensively in marine waters and may utilize multiple river systems for nursery and foraging habitat in addition to their natal spawning river, they are subject to being caught in multiple fisheries throughout their range. In addition to direct mortality, stress or injury to Atlantic sturgeon taken as bycatch but released alive may result in increased susceptibility to other threats, such as poor water quality (e.g., exposure to toxins). This may result in reduced ability to perform major life functions, such as foraging and spawning, or even post-capture mortality. While many of the threats to the Carolina DPS have been ameliorated or reduced due to the existing regulatory mechanisms, such as the moratorium on directed fisheries for Atlantic sturgeon, bycatch is currently not being addressed through existing mechanisms. Further, access to habitat and water quality continues to be a problem even with NMFS' authority under the Federal Power Act to recommend fish passage and existing controls on some pollution sources. The inadequacy of regulatory mechanisms to control bycatch and habitat alterations is contributing to the status of the Carolina DPS.

5.11 South Atlantic DPS of Atlantic sturgeon

The South Atlantic DPS includes all Atlantic sturgeon that spawn or are spawned in the watersheds (including all rivers and tributaries) of the Ashepoo, Combahee, and Edisto Rivers (ACE) Basin southward along the South Carolina, Georgia, and Florida coastal areas to the St. Johns River, Florida. The marine range of Atlantic sturgeon from the South Atlantic DPS extends from the Hamilton Inlet, Labrador, Canada, to Cape Canaveral, Florida.

Rivers known to have current spawning populations within the range of the South Atlantic DPS include the Combahee, Edisto, Savannah, Ogeechee, Altamaha, and Satilla Rivers. We determined spawning was occurring if young-of-the-year (YOY) were observed, or mature adults were present, in freshwater portions of a system (Table 4). However, in some rivers, spawning by Atlantic sturgeon may not be contributing to population growth because of lack of suitable habitat and the presence of other stressors on juvenile survival and development. Historically, both the Broad-Coosawatchie and St. Marys Rivers were documented to have spawning populations at one time; there is also evidence that spawning may have occurred in the St. Johns River or one of its tributaries. However, the spawning population in the St. Marys River, as well as any historical spawning population present in the St. Johns, is believed to be extirpated, and the status of the spawning population in the Broad-Coosawatchie is unknown. Both the St. Marys and St. Johns Rivers are used as nursery habitat by young Atlantic sturgeon originating from other spawning populations. The use of the Broad-Coosawatchie by sturgeon from other spawning populations is

unknown at this time. The presence of historical and current spawning populations in the Ashepoo River has not been documented; however, this river may currently be used for nursery habitat by young Atlantic sturgeon originating from other spawning populations. This represents our current knowledge of the river systems utilized by the South Atlantic DPS for specific life functions, such as spawning, nursery habitat, and foraging. However, fish from the South Atlantic DPS likely use other river systems than those listed here for their specific life functions.

River/Estuary	Spawning Population	Data
ACE (Ashepoo, Combahee, and Edisto Rivers) Basin, SC; St. Helena Sound	Yes	1,331 YOY (1994-2001); gravid female and running ripe male in the Edisto (1997); 39 spawning adults (1998)
Broad-Coosawhatchie Rivers, SC; Port Royal Sound	Unknown	
Savannah River, SC/GA	Yes	22 YOY (1999-2006); running ripe male (1997)
Ogeechee River, GA	Yes	age-1 captures, but high inter-annual variability (1991-1998); 17 YOY (2003); 9 YOY (2004)
Altamaha River, GA	Yes	74 captured/308 estimated spawning adults (2004); 139 captured/378 estimated spawning adults (2005)
Satilla River, GA	Yes	4 YOY and spawning adults (1995-1996)
St. Marys River, GA/FL	Extirpated	
St. Johns River, FL	Extirpated	

Table 4. Major rivers, tributaries, and sounds within the range of the South Atlantic DPS and currently available data on the presence of an Atlantic sturgeon spawning population in each system.

The riverine spawning habitat of the South Atlantic DPS occurs within the South Atlantic Coastal Plain ecoregion (TNC 2002b), which includes fall-line sandhills, rolling longleaf pine uplands, wet pine flatwoods, isolated depression wetlands, small streams, large river systems, and estuaries. Other ecological systems in the ecoregion include maritime forests on barrier islands, pitcher plant seepage bogs and Altamaha grit (sandstone) outcrops. Other ecological systems in the ecoregion include maritime forests on barrier islands, pitcher plant seepage bogs and Altamaha grit (sandstone) outcrops. The primary threats to biological diversity in the South Atlantic Coastal Plain listed by TNC are intensive silvicultural practices, including conversion of natural forests to highly managed pine monocultures and the clear-cutting of bottomland hardwood forests. Changes in water quality and quantity, caused by hydrologic alterations (impoundments, groundwater withdrawal, and ditching), and point and nonpoint pollution, are threatening the aquatic systems. Development is a growing threat, especially in coastal areas. Agricultural conversion, fire regime

alteration, and the introduction of nonnative species are additional threats to the ecoregion's diversity. The South Atlantic DPS' spawning rivers, located in the South Atlantic Coastal Plain, are primarily of two types: brownwater (with headwaters north of the Fall Line, silt-laden) and blackwater (with headwaters in the coastal plain, stained by tannic acids).

Secor (2002) estimates that 8,000 adult females were present in South Carolina prior to 1890. Prior to the collapse of the fishery in the late 1800s, the sturgeon fishery was the third largest fishery in Georgia. Secor (2002) estimated from U.S. Fish Commission landing reports that approximately 11,000 spawning females were likely present in the state prior to 1890. Reductions from the commercial fishery and ongoing threats have drastically reduced the numbers of Atlantic sturgeon within the South Atlantic DPS. Currently, the Atlantic sturgeon spawning population in at least two river systems within the South Atlantic DPS has been extirpated. The Altamaha River population of Atlantic sturgeon, with an estimated 343 adults spawning annually, is believed to be the largest population in the Southeast, yet is estimated to be only 6 percent of its historical population size. The abundances of the remaining river populations within the DPS, each estimated to have fewer than 300 spawning adults, is estimated to be less than 1 percent of what they were historically (ASSRT 2007).

Threats

The South Atlantic DPS was listed as endangered under the ESA as a result of a combination of habitat curtailment and modification, overutilization (i.e, being taken as bycatch) in commercial fisheries, and the inadequacy of regulatory mechanisms in ameliorating these impacts and threats.

The modification and curtailment of Atlantic sturgeon habitat resulting from dredging and degraded water quality is contributing to the status of the South Atlantic DPS. Dredging is a present threat to the South Atlantic DPS and is contributing to their status by modifying the quality and availability of Atlantic sturgeon habitat. Maintenance dredging is currently modifying Atlantic sturgeon nursery habitat in the Savannah River and modeling indicates that the proposed deepening of the navigation channel will result in reduced DO and upriver movement of the salt wedge, curtailing spawning habitat. Dredging is also modifying nursery and foraging habitat in the St. Johns Rivers. Reductions in water quality from terrestrial activities have modified habitat utilized by the South Atlantic DPS. Low DO is modifying sturgeon habitat in the Savannah due to dredging, and non-point source inputs are causing low DO in the Ogeechee River and in the St. Marys River, which completely eliminates juvenile nursery habitat in summer. Low DO has also been observed in the St. Johns River in the summer. Sturgeon are more sensitive to low DO and the negative (metabolic, growth, and feeding) effects caused by low DO increase when water temperatures are concurrently high, as they are within the range of the South Atlantic DPS. Additional stressors arising from water allocation and climate change threaten to exacerbate water quality problems that are already present throughout the range of the South Atlantic DPS. Large withdrawals of over 240 million gallons per day mgd of water occur in the Savannah River for power generation and municipal uses. However, users withdrawing less than 100,000 gallons per day (gpd) are not required to get permits, so actual water withdrawals from the Savannah and other rivers within the range of the South Atlantic DPS are likely much higher. The removal of large amounts of water from the system will alter flows, temperature, and DO. Water shortages and "water wars" are already occurring in the rivers occupied by the South Atlantic DPS and will likely be compounded in the future by population growth and potentially by climate change. Climate change is also predicted to elevate

water temperatures and exacerbate nutrient-loading, pollution inputs, and lower DO, all of which are current stressors to the South Atlantic DPS.

Overutilization of Atlantic sturgeon from directed fishing caused initial severe declines in Atlantic sturgeon populations in the Southeast, from which they have never rebounded. Further, continued overutilization of Atlantic sturgeon as bycatch in commercial fisheries is an ongoing impact to the South Atlantic DPS. The loss of large subadults and adults as a result of bycatch impacts Atlantic sturgeon populations because they are a long-lived species, have an older age at maturity, have lower maximum fecundity values, and a large percentage of egg production occurs later in life. Little data exists on bycatch in the Southeast and high levels of bycatch underreporting are suspected. Further, a total population abundance for the DPS is not available, and it is therefore not possible to calculate the percentage of the DPS subject to bycatch mortality based on the available bycatch mortality rates for individual fisheries. However, fisheries known to incidentally catch Atlantic sturgeon occur throughout the marine range of the species and in some riverine waters as well. Because Atlantic sturgeon mix extensively in marine waters and may access multiple river systems, they are subject to being caught in multiple fisheries throughout their range. In addition, stress or injury to Atlantic sturgeon taken as bycatch but released alive may result in increased susceptibility to other threats, such as poor water quality (e.g., exposure to toxins and low DO). This may result in reduced ability to perform major life functions, such as foraging and spawning, or even post-capture mortality.

As a wide-ranging anadromous species, Atlantic sturgeon are subject to numerous Federal (U.S. and Canadian), state and provincial, and inter-jurisdictional laws, regulations, and agency activities. While these mechanisms have addressed impacts to Atlantic sturgeon through directed fisheries, there are currently no mechanisms in place to address the significant risk posed to Atlantic sturgeon from commercial bycatch. Though statutory and regulatory mechanisms exist that authorize reducing the impact of dams on riverine and anadromous species, such as Atlantic sturgeon, and their habitat, these mechanisms have proven inadequate for preventing dams from blocking access to habitat upstream and degrading habitat downstream. Further, water quality continues to be a problem in the South Atlantic DPS, even with existing controls on some pollution sources. Current regulatory regimes are not necessarily effective in controlling water allocation issues (e.g., no permit requirements for water withdrawals under 100,000 gpd in Georgia, no restrictions on interbasin water transfers in South Carolina, the lack of ability to regulate non-point source pollution.)

The recovery of Atlantic sturgeon along the Atlantic Coast, especially in areas where habitat is limited and water quality is severely degraded, will require improvements in the following areas: (1) elimination of barriers to spawning habitat either through dam removal, breaching, or installation of successful fish passage facilities; (2) operation of water control structures to provide appropriate flows, especially during spawning season; (3) imposition of dredging restrictions including seasonal moratoriums and avoidance of spawning/nursery habitat; and, (4) mitigation of water quality parameters that are restricting sturgeon use of a river (i.e., DO). Additional data regarding sturgeon use of riverine and estuarine environments is needed.

A viable population able to adapt to changing environmental conditions is critical to Atlantic sturgeon, and the low population numbers of every river population in the South Atlantic DPS put

them in danger of extinction throughout their range; none of the populations are large or stable enough to provide with any level of certainty for continued existence of Atlantic sturgeon in this part of its range. Although the largest impact that caused the precipitous decline of the species has been curtailed (directed fishing), the population sizes within the South Atlantic DPS have remained relatively constant at greatly reduced levels (approximately 6 percent of historical population sizes in the Altamaha River, and 1 percent of historical population sizes in the remainder of the DPS) for 100 years. Small numbers of individuals resulting from drastic reductions in populations, such as occurred with Atlantic sturgeon due to the commercial fishery, can remove the buffer against natural demographic and environmental variability provided by large populations (Berry, 1971; Shaffer, 1981; Soulé, 1980). Recovery of depleted populations is an inherently slow process for a late-maturing species such as Atlantic sturgeon, and they continue to face a variety of other threats that contribute to their risk of extinction. Their late age at maturity provides more opportunities for individual Atlantic sturgeon to be removed from the population before reproducing. While a long life-span also allows multiple opportunities to contribute to future generations, it also results in increases the timeframe over which exposure to the multitude of threats facing the South Atlantic DPS can occur.

Summary of the Status of the South Atlantic DPS of Atlantic Sturgeon

The South Atlantic DPS is estimated to number fewer than 6 percent of its historical population size, with all river populations except the Altamaha estimated to be less than 1 percent of historical abundance. There are an estimated 343 spawning adults per year in the Altamaha and less than 300 spawning adults per year (total of both sexes) in each of the other major river systems occupied by the DPS in which spawning still occurs, whose freshwater range occurs in the watersheds (including all rivers and tributaries) of the ACE Basin southward along the South Carolina, Georgia, and Florida coastal areas to the St. Johns River, Florida. Recovery of depleted populations is an inherently slow process for a late-maturing species such as Atlantic sturgeon. Their late age at maturity provides more opportunities for individuals to be removed from the population before reproducing. While a long life-span also allows multiple opportunities to contribute to future generations, this is hampered within the South Atlantic DPS by habitat alteration, bycatch, and from the inadequacy of existing regulatory mechanisms to address and reduce habitat alterations and bycatch.

Dredging is contributing to the status of the South Atlantic DPS by modifying spawning, nursery, and foraging habitat. Habitat modifications through reductions in water quality are also contributing to the status of the South Atlantic DPS through reductions in DO, particularly during times of high water temperatures, which increase the detrimental effects on Atlantic sturgeon habitat. Interbasin water transfers and climate change threaten to exacerbate existing water quality issues. Bycatch is also a current impact to the South Atlantic DPS that is contributing to its status. Fisheries known to incidentally catch Atlantic sturgeon occur throughout the marine range of the species and in some riverine waters as well. Because Atlantic sturgeon mix extensively in marine waters and may utilize multiple river systems for nursery and foraging habitat in addition to their natal spawning river, they are subject to being caught in multiple fisheries throughout their range. In addition to direct mortality, stress or injury to Atlantic sturgeon taken as bycatch but released alive may result in increased susceptibility to other threats, such as poor water quality (e.g., exposure to toxins). This may result in reduced ability to perform major life functions, such as foraging and spawning, or even post-capture mortality. While many of the threats to the South

Atlantic DPS have been ameliorated or reduced due to the existing regulatory mechanisms, such as the moratorium on directed fisheries for Atlantic sturgeon, bycatch is currently not being addressed through existing mechanisms. Further, access to habitat and water quality continues to be a problem even with NMFS' authority under the Federal Power Act to recommend fish passage and existing controls on some pollution sources. There is a lack of regulation for some large water withdrawals, which threatens sturgeon habitat. Current regulatory regimes do not require a permit for water withdrawals under 100,000 gpd in Georgia and there are no restrictions on interbasin water transfers in South Carolina. Data required to evaluate water allocation issues are either very weak, in terms of determining the precise amounts of water currently being used, or non-existent, in terms of our knowledge of water supplies available for use under historical hydrologic conditions in the region. Existing water allocation issues will likely be compounded by population growth, drought, and potentially climate change. The inadequacy of regulatory mechanisms to control bycatch and habitat alterations is contributing to the status of the South Atlantic DPS.

6.0 ENVIRONMENTAL BASELINE

Environmental baselines for biological opinions include the past and present impacts of all state, federal or private actions and other human activities in the action area, the anticipated impacts of all proposed federal projects in the action area that have already undergone formal or early Section 7 consultation, and the impact of state or private actions that are contemporaneous with the consultation in process (50 CFR § 402.02). The environmental baseline for this Opinion includes the effects of several activities that may affect the survival and recovery of the listed species in the action area. The activities that shape the environmental baseline in the action area of this consultation generally include: dredging operations, water quality, scientific research, shipping and other vessel traffic and fisheries, and recovery activities associated with reducing those impacts.

6.1 Federal Actions that have Undergone Formal or Early Section 7 Consultation

NMFS has undertaken several ESA section 7 consultations to address the effects of actions authorized, funded or carried out by Federal agencies. Each of those consultations sought to develop ways of reducing the probability of adverse impacts of the action on listed species. Consultations are detailed below.

6.1.1 Maintenance of Federal Navigation Projects and Use of Sand Borrow Areas

USACE and NMFS have consulted previously on dredging of Federal navigation channels and borrow areas in the lower Chesapeake Bay. The use of endangered species observers began in 1994. Since then, a total of 64 sea turtles and two Atlantic sturgeon have been observed entrained in hopper dredges operating in the action area. All of these individuals were dead at the time of observation. Additionally, sea turtles and Atlantic sturgeon have been captured and released during sea turtle relocation trawling in association with hopper dredging. One sea turtle mortality has been recorded during relocation trawling. No interactions between sea turtles or Atlantic sturgeon have been observed during projects using a hydraulic pipeline or mechanical dredge. We are currently engaged in a consultation to consider the effects of dredging in all Federal navigation projects and sand borrow areas in the lower Chesapeake Bay.

6.1.2 Scientific Studies

There is currently one scientific research permits issued pursuant to Section 10(a)(1)(A) of the ESA, that authorize research on Atlantic sturgeon in the action area. Permit 16547 authorizes the US Fish and Wildlife Service to conduct research activities on Atlantic sturgeon in the Chesapeake Bay and

tidal tributaries in Virginia. There is the potential for some research to take place in the action area. The permit authorizes the non-lethal capture, handling and sampling of a number of sturgeon and the unintentional mortality of three Atlantic sturgeon over the five year life of this permit. The permit expires in April 2017.

Several researchers, including the NMFS Northeast and Southeast Science Centers and several academic and independent researchers are authorized under various Section 10(a)(1)(A) permits to conduct surveys and sample sea turtles. Some of this activity may occur in the action area. More information on these permits can be obtained from: <https://apps.nmfs.noaa.gov>.

6.1.3 Vessel Operations

Potential adverse effects from federal vessel operations in the action area of this consultation include operations of the US Navy (USN) and the US Coast Guard (USCG), which maintain the largest federal vessel fleets, the EPA, the National Oceanic and Atmospheric Administration (NOAA), and the USACE. NMFS has conducted formal consultations with the USCG, the USN, EPA and NOAA on their vessel operations. In addition to operation of USACE vessels, NMFS has consulted with the USACE to provide recommended permit restrictions for operations of contract or private vessels around whales. Through the section 7 process, where applicable, NMFS has and will continue to establish conservation measures for all these agency vessel operations to avoid adverse effects to listed species. Refer to the biological opinions for the USCG (September 15, 1995; July 22, 1996; and June 8, 1998) and the USN (May 15, 1997) for detail on the scope of vessel operations for these agencies and conservation measures being implemented as standard operating procedures. No interactions with sturgeon or sea turtles have been reported with any of the vessels considered in these Opinions.

6.1.4 Authorization of Fisheries through Fishery Management Plans

NMFS authorizes the operation of several fisheries in the action area under the authority of the Magnuson-Stevens Fishery Conservation Act and through Fishery Management Plans and their implementing regulations. Commercial and recreational fisheries in the action area employ gear that is known to harass, injure, and/or kill sea turtles and Atlantic sturgeon. In the Northeast Region (Maine through Virginia), formal ESA section 7 consultations have been conducted on the American lobster, Atlantic bluefish, Atlantic mackerel/squid/ butterfish, Atlantic sea scallop, monkfish, northeast multispecies, red crab, spiny dogfish, summer flounder/scup/black sea bass, and tilefish fisheries. These consultations have considered effects to loggerhead, green, Kemp's ridley and leatherback sea turtles. We have completed Biological Opinions on the operations of these fisheries. In each of these Opinions, we concluded that the ongoing action was likely to adversely affect but was not likely to jeopardize the continued existence of any sea turtle species. Each of these Opinions included an incidental take statement (ITS) exempting a certain amount of lethal and/or non-lethal take resulting from interactions with the fishery. These ITSs are summarized in the table below. Further, in each Opinion, we concluded that the potential for interactions (i.e., vessel strikes) between sea turtles and fishing vessels was extremely low and similarly that any effects to sea turtle prey and/or habitat would be insignificant and discountable. We have also determined that the Atlantic herring and surf clam/ocean quahog fisheries do not adversely affect any species of listed sea turtles.

NMFS' Southeast Regional Office has carried out formal ESA section 7 consultations for several FMPs with action areas that at least partially overlap with the NEAMAP action area. These

include: coastal migratory pelagics, swordfish/tuna/shark/ billfish (highly migratory species), snapper/grouper, dolphin/wahoo, and the Southeast shrimp trawl fisheries. The ITSs provided with these Opinions are included in the table below.

In addition to these consultations, NMFS has conducted a formal consultation on the pelagic longline component of the Atlantic highly migratory species FMP. Portions of this fishery occur within the NEAMAP action area. In a June 1, 2004 Opinion, NMFS concluded that the ongoing action was likely to adversely affect but was not likely to jeopardize the continued existence of loggerhead, Kemp’s ridley or green sea turtles but was likely to jeopardize the continued existence of leatherback sea turtles. This Opinion included a Reasonable and Prudent Alternative that when implemented would modify operations of the fishery in a way that would remove jeopardy. This fishery is currently operated in a manner that is consistent with the RPA. The RPA included an ITS which is reflected in the table below. Unless specifically noted, all numbers denote an annual number of captures that may be lethal or non-lethal.

Table 5. Information on Fisheries Opinions conducted by NMFS NERO and SERO for federally managed fisheries that operate in the action area

FMP	Date of Most Recent Opinion	Loggerhead	Kemp’s ridley	Green	Leatherback
American lobster	August 3, 2012	1	0	0	5
Atlantic bluefish	October 29, 2010	82 (34 lethal)	4	5	4
Monkfish	October 29, 2010	173 (70 lethal)	4	5	4
Multispecies	October 29, 2010	46 in trawls (21 lethal)	4	5	4
Skate	October 29, 2010	39 (17 lethal)	4	5	4
Spiny dogfish	October 29, 2010	2	4	5	4
Mackerel/squid/butterfish	October 29, 2010	62 (25 lethal)	2	2	2
Summer flounder/scup/black sea bass	October 29, 2010	205 (85 lethal)	4	5	6
Shark fisheries as managed under the Consolidated HMS FMP	May 20, 2008	679 (349 lethal) every 3 years	2 (1 lethal) every 3 years	2 (1 lethal) every 3 years	74 (47 lethal) every 3 years
Atlantic sea scallop	July 12, 2012	2012: 301 (195 lethal); 2013 and beyond: 301 (115 lethal)	3	2	2

Coastal migratory pelagic	August 13, 2007	33 every 3 years	4 every 3 years	14 every 3 years	2 every 3 years
Pelagic longline under the HMS FMP (per the RPA)	June 1, 2004	1,905 (339 lethal) every 3 years	*105 (18 lethal) every 3 years	*105 (18 lethal) every 3 years	1764 (252 lethal) every 3 years

**combination of 105 (18 lethal) Kemp's ridley, green, hawksbill, or Olive ridley*

We are in the process of reinitiating consultations that consider fisheries actions that may affect Atlantic sturgeon. Sturgeon originating from the five DPSs considered in this consultation are known to be captured and killed in fisheries operated in the action area. At the time of this writing, no Opinions considering effects of federally authorized fisheries on any DPS of Atlantic sturgeon have been completed. As noted in the Status of the Species section above, the NEFSC prepared a bycatch estimate for Atlantic sturgeon captured in sink gillnet and otter trawl fisheries operated from Maine through Virginia. This estimate indicates that, based on data from 2006-2010, annually, an average of 3,118 Atlantic sturgeon are captured in these fisheries with 1,569 in sink gillnet and 1,548 in otter trawls. The mortality rate in sink gillnets is estimated at approximately 20% and the mortality rate in otter trawls is estimated at 5%. Based on this estimate, a total of 391 Atlantic sturgeon are estimated to be killed annually in these fisheries that are prosecuted in the action area. We are currently in the process of determining the effects of this annual loss to each of the DPSs. At this time, there is no bycatch estimate for fisheries that are regulated by NMFS SERO. Any of these fisheries that operate with sink gillnets or otter trawls are likely to interact with Atlantic sturgeon and be an additional source of mortality in the action area. Also, as noted above, NMFS SERO has reinitiated the consultation for shrimp trawling; consultation on the smooth dogfish fishery is also currently being conducted by SERO in coordination with NMFS HMS.

6.1.4 Other Federally Authorized Actions

We have completed several informal consultations on effects of in-water construction activities in the Chesapeake Bay permitted by the USACE. This includes several dock, pier and bank stabilization projects. No interactions with shortnose or Atlantic sturgeon have been reported in association with any of these projects.

We have also completed several informal consultations on effects of private dredging projects permitted by the USACE. All of the dredging was with a mechanical or cutterhead dredge. No interactions with shortnose or Atlantic sturgeon have been reported in association with any of these projects.

6.2 State or Private Actions in the Action Area

6.2.1 State Authorized Fisheries

Atlantic and shortnose sturgeon, and sea turtles may be vulnerable to capture, injury and mortality in fisheries occurring in state waters. The action area includes portions of Virginia state waters. Information on the number of sturgeon captured or killed in state fisheries is extremely limited and as such, efforts are currently underway to obtain more information on the numbers of sturgeon captured and killed in state water fisheries. We are currently working with the Atlantic States

Marine Fisheries Commission (ASMFC) and the coastal states to assess the impacts of state authorized fisheries on sturgeon. We anticipate that some states are likely to apply for ESA section 10(a)(1)(B) Incidental Take Permits to cover their fisheries; however, to date, no applications have been submitted. Below, we discuss the different fisheries authorized by the states and any available information on interactions between these fisheries and sturgeon.

American Eel

American eel (*Anguilla rostrata*) is exploited in fresh, brackish and coastal waters from the southern tip of Greenland to northeastern South America. American eel fisheries are conducted primarily in tidal and inland waters. Eels are typically caught with hook and line or with eel traps and may also be caught with fyke nets. Sturgeon and sea turtles are not known to interact with the eel fishery.

Atlantic croaker

Atlantic croaker (*Micropogonias undulates*) occur in coastal waters from the Gulf of Maine to Argentina, and are one of the most abundant inshore bottom-dwelling fish along the U.S. Atlantic coast. Atlantic croaker are managed under an ASMFC ISFMP (including Amendment 1 in 2005 and Addendum 1 in 2010), but no specific management measures are required.

Recreational fisheries for Atlantic croaker are likely to use hook and line; commercial fisheries targeting croaker primarily use otter trawls. The average annual bycatch of loggerhead sea turtles in bottom otter trawl gear used in the Atlantic croaker fishery was estimated to be 70 loggerhead sea turtles (Warden 2011). Additional information on sea turtle interactions with gillnet gear, including gillnet gear used in the Atlantic croaker fishery, has also been recently published by Murray (2009a, 2009b). The average annual bycatch of loggerhead sea turtles in gillnet gear used in the Atlantic croaker fishery, based on VTR data from 2002-2006, was estimated to be 11 per year with a 95% CI of 3-20 (Murray 2009b). A quantitative assessment of the number of Atlantic sturgeon captured in the croaker fishery is not available. Mortality rates of Atlantic sturgeon in commercial trawls has been estimated at 5%. A review of the NEFOP database indicates that from 2006-2010, 60 Atlantic sturgeon (out of a total of 726 observed interactions) were captured during observed trips where the trip target was identified as croaker. This represents a minimum number of Atlantic sturgeon captured in the croaker fishery during this time period as it only considers observed trips for boats with federal permits only. We do not have an estimate of the number of interactions between sturgeon or sea turtles with the croaker fishery in the action area.

Horseshoe crabs

ASMFC manages horseshoe crabs through an Interstate Fisheries Management Plan that sets state quotas, and allows states to set closed seasons. Horseshoe crabs are present in Chesapeake Bay. Stein *et al.* (2004) examined bycatch of Atlantic sturgeon using the NMFS sea-sampling/observer database (1989-2000) and found that the bycatch rate for horseshoe crabs was very low, at 0.05%. Few Atlantic sturgeon are expected to be caught in the horseshoe crab fishery in the action area. Sea turtles are not known to be captured during horseshoe crab fishing.

Striped bass

Striped bass are managed by ASMFC through Amendment 6 to the Interstate FMP, which requires minimum sizes for the commercial and recreational fisheries, possession limits for the recreational fishery, and state quotas for the commercial fishery (ASMFC 2003). Under Addendum 2, the coastwide striped bass quota remains the same, at 70% of historical levels. Data from the Atlantic

Coast Sturgeon Tagging Database (2000-2004) shows that the striped bass fishery accounted for 43% of Atlantic sturgeon recaptures; however, no information on the total number of Atlantic sturgeon caught by fishermen targeting striped bass or the mortality rate is available. No information on interactions between sea turtles and the striped bass fishery is available.

Weakfish

The weakfish fishery occurs in both state and federal waters but the majority of commercially and recreationally caught weakfish are caught in state waters (ASMFC 2002). The dominant commercial gears include gill nets, pound nets, haul seines, and trawls, with the majority of landings occurring in the fall and winter months (ASMFC 2002). Fishing for weakfish occurs in Delaware Bay.

The average annual bycatch of loggerhead sea turtles in bottom otter trawl gear used in the weakfish fishery was estimated to be 1 loggerhead sea turtle (Warden 2011). Additional information on sea turtle interactions with gillnet gear, including gillnet gear used in the weakfish fishery, has also been recently published by Murray (2009a, 2009b). The average annual bycatch of loggerhead sea turtles in gillnet gear used in the weakfish fishery, based on VTR data from 2002-2006, was estimated to be one (1) per year with a 95% CI of 0-1 (Murray 2009b).

A quantitative assessment of the number of Atlantic sturgeon captured in the weakfish fishery is not available. A review of the NEFOP database indicates that from 2006-2010, 36 Atlantic sturgeon (out of a total of 726 observed interactions) were captured during observed trips where the trip target was identified as weakfish. This represents a minimum number of Atlantic sturgeon captured in the weakfish fishery during this time period as it only considers observed trips, and most inshore fisheries are not observed. An earlier review of bycatch rates and landings for the weakfish fishery reported that the weakfish-stripped bass fishery had an Atlantic sturgeon bycatch rate of 16% from 1989-2000; the weakfish-Atlantic croaker fishery had an Atlantic sturgeon bycatch rate of 0.02%, and the weakfish fishery had an Atlantic sturgeon bycatch rate of 1.0% (ASSRT 2007).

American lobster trap fishery

An American lobster trap fishery also occurs in Chesapeake Bay. This fishery is managed under the ASMFC's ISFMP. This fishery has also been identified as a source of gear causing injuries to and mortality of loggerhead and leatherback sea turtles as a result of entanglement in vertical buoy lines of the pot/trap gear. Between 2002 and 2008, the lobster trap fishery in state waters was verified as the fishery involved in at least 27 leatherback entanglements in the Northeast Region. All entanglements involved the vertical line of the gear. These verified/confirmed entanglements occurred in Maine, Massachusetts, and Rhode Island state waters from June through October (Northeast Region STDN database). While no entanglements in lobster gear have been reported for Chesapeake Bay, the potential for future entanglement exists. Atlantic sturgeon are not known to interact with lobster trap gear.

Poundnet Fishery

This fishery is managed by the states, except for regulations NMFS issued under the authority of the ESA to protect sea turtles. Pound nets with large mesh and stringer leaders set in the Chesapeake Bay have been observed to lethally take turtles as a result of entanglement in the leader. Virginia sea turtle strandings during the spring are consistently high, and given the best available information, including observer reports, the nature and location of the turtle strandings, the type of

fishing gear in the vicinity of the greatest number of strandings, and the known interactions between sea turtles and large mesh and stringer pound net leaders, pound nets were considered to be a likely contributor to high sea turtle strandings in 2001 (and likely every spring). NMFS conducted pound net monitoring during the spring of 2002 and 2003. This monitoring documented 23 sea turtles either entangled in or impinged on pound net leaders, 18 of which were in leaders with less than 12 inches (30.5 cm) stretched mesh. Nine animals were found entangled in leaders, of which 7 were dead, and 14 animals were found impinged on leaders, of which one was dead. In this situation, impingement refers to a sea turtle being held against the leader by the current, apparently unable to release itself under its own ability.

In 2004 and 2005, NMFS implemented a coordinated research program with pound net industry participants and other interested parties to develop and test a modified pound net leader design with the goal of eliminating or reducing sea turtle interactions while retaining an acceptable level of fish catch. During the 2-year study, the modified leader was found effective in reducing sea turtle interactions as compared to the unmodified leader. The final results of the 2004 study found that out of eight turtles impinged on or entangled in pound net leaders, seven were in an unmodified leader. One leatherback turtle was found entangled in the vertical lines of a modified leader. In response to the leatherback entanglement, the gear was further modified by increasing the stiffness of the vertical lines for the 2005 experiment. In 2005, 15 turtles entangled in or impinged on the leaders of unmodified leaders, and no turtles were found entangled in or impinged on modified leaders. In addition, there have been documented interactions between pound nets and Atlantic sturgeon; however, neither an interaction rate or mortality rate is currently available.

Whelk and blue crab fisheries

A whelk fishery using pot/trap gear is known to occur in offshore Virginia. This fishery operates when sea turtles may be in the area. Sea turtles (loggerheads and Kemp's ridleys in particular) are believed to become entangled in the top bridle line of the whelk pot, given a few documented entanglements of loggerheads in whelk pots, the configuration of the gear, and the turtles' preference for the pot contents. Research is underway to determine the magnitude of these interactions and to develop gear modifications to reduce these potential entanglements. In New England waters, leatherbacks have been found entangled in whelk pot lines, so if leatherback turtles overlap with this gear in the action area, entanglement may occur. The blue crab fishery using pot/trap gear also occurs in the action area. The magnitude of interactions with these pots and sea turtles is unknown, but loggerheads and leatherbacks have been found entangled in this gear. For instance, in May and June 2002, three leatherbacks were documented entangled in crab pot gear in various areas of the Chesapeake Bay. Given the plethora of crab pot gear throughout the action area, it is possible that these interactions are more frequent than what has been documented. No interactions between Atlantic sturgeon and crab pot gear has been reported to NMFS.

6.3 Other Impacts of Human Activities in the Action Area

6.3.1 Contaminants and Water Quality

Point source discharges (i.e., municipal wastewater, paper mill effluent, industrial or power plant cooling water or waste water) and compounds associated with discharges (i.e., metals, dioxins, dissolved solids, phenols, and hydrocarbons) contribute to poor water quality and may also impact the health of sturgeon populations. The compounds associated with discharges can alter the pH of receiving waters, which may lead to mortality, changes in fish behavior, deformations, and reduced

egg production and survival. Agriculture and forestry occur within the Chesapeake Bay watershed, which potentially results in an increase in the amount of suspended sediment present in the river. Concentrated amounts of suspended solids discharged into a river system may lead to smothering of fish eggs and larvae and may result in a reduction in the amount of available dissolved oxygen.

Within the action area, sea turtles and optimal sea turtle habitat most likely have been impacted by pollution. Marine debris (e.g., discarded fishing line or lines from boats) can entangle turtles in the water and drown them. Turtles commonly ingest plastic or mistake debris for food, as observed with the leatherback sea turtle. The leatherback's preferred diet includes jellyfish, but similar looking plastic bags are often found in the turtle's stomach contents (Magnuson *et al.* 1990).

Chemical contaminants may also have an effect on sea turtle reproduction and survival. While the effects of contaminants on turtles is relatively unclear, pollution may be linked to the fibropapilloma virus that kills many turtles each year (NMFS 1997). If pollution is not the causal agent, it may make sea turtles more susceptible to disease by weakening their immune systems. Furthermore, the Bay watershed is highly developed, which contributes to impaired water quality via stormwater runoff or point sources. The mainstem Chesapeake Bay has historically low levels of chemical contamination (Chesapeake Bay Program Office 1999).

Excessive turbidity due to coastal development and/or construction sites could influence sea turtle foraging ability. Turtles are not very easily affected by changes in water quality or increased suspended sediments, but if these alterations make habitat less suitable for turtles and hinder their capability to forage, eventually they would tend to leave or avoid these less desirable areas (Ruben and Morreale 1999).

Water quality issues have been reported in at least localized areas of the Chesapeake Bay since the advent of the use of industrial fertilizers in the 1830s. Pollution increased in the Bay through the 19th century as increasing amounts of land were cleared and as industrial use of the area surrounding the Bay increased. Declines in shellfish beds were first reported in 1900 and by the 1940s advancements in fishing technology lead to decreases in fish populations in the Bay. Excess pollution to the Bay continued through to the early 1970s when regulation first began with the passage of the Clean Water Act. Also in the early 1970s, decreases in Bay grasses were recorded and a significant portion of bay grasses were destroyed by Tropical Storm Agnes in 1972. The loss of native oysters throughout the second half of the 20th century, largely due to introduced disease, also affected water quality in the Bay. In 1983, the first comprehensive report of Bay water quality highlights four areas of concern: an overabundance of nitrogen and phosphorous pollution; dwindling underwater bay grasses; toxic chemical pollution; and, over-harvesting of living resources.

Since 1983, significant efforts have been made to clean up the Chesapeake Bay. While the levels of toxins and industrial pollutants have decreased, leading to largely improved water quality conditions, the Chesapeake Bay still faces many problems and remains polluted. Despite small successes in certain areas, the overall health of the Chesapeake Bay remains degraded.

Excess nutrients, such as nitrogen and phosphorous are pollutants. Rain washes nutrients off streets, rooftops, lawns, farms and industrial sites into the streams and rivers that flow into the Bay. Nutrient pollution is the largest problem currently affecting the Chesapeake Bay. Excess nutrients cause rapid growth of algae blooms which cloud the water and reduce the amount of sunlight

reaching the Bay's aquatic life. When the algae blooms die, oxygen is depleted as the algae decay. Nutrients and sediment flowing into the Bay have reduced oxygen levels below what is needed by much of the aquatic life in the Bay.

Although there were improvements in the some areas of the Bay's health in 2009, the ecosystem remains in poor condition. EPA ranked the overall health of the Bay an average of 45 percent based on goals for water quality, habitats, and lower food web, and fish and shellfish abundance. This was a 6 percent increase from 2008. According to EPA, the modest gain in the health score was due to a large increase in adult blue crab population, expansion of underwater grass beds growing in the Bay's shallows, and improvements in water clarity and bottom habitat health as highlighted below:

- 12 percent of the Bay and its tidal tributaries met Clean Water Act standards for dissolved oxygen between 2007-2009, a decrease of 5 percent from 2006-2008.
- 26 percent of the tidal waters met or exceeded guidelines for water clarity, a 12 percent increase from 2008.
- Underwater bay grasses covered 9,039 more acres of the Bay's shallow waters for a total of 85,899 acres, 46 percent of the Bay-wide goal.
- The health of the Bay's bottom dwelling species reach a record high of 56 percent of the goal, improving by approximately 15 Bay-wide.
- The adult blue crab population increased to 223 million, its highest level since 1993.

7.0 Climate Change

The discussion below presents background information on global climate change and information on past and predicted future effects of global climate change throughout the range of the listed species considered here. Additionally, we present the available information on predicted effects of climate change in the action area (i.e., the lower Chesapeake Bay) and how listed sea turtles and sturgeon may be affected by those predicted environmental changes over the life of the proposed action (i.e., between now and 2062). Climate change is relevant to the Status of the Species, Environmental Baseline and Cumulative Effects sections of this Opinion; rather than include partial discussion in several sections of this Opinion, we are synthesizing this information into one discussion. Consideration of effects of the proposed action in light of predicted changes in environmental conditions due to anticipated climate change are included in the Effects of the Action section below (section 8.0 below).

7.1 Background Information on Global climate change

The global mean temperature has risen 0.76°C (1.36°F) over the last 150 years, and the linear trend over the last 50 years is nearly twice that for the last 100 years (Intergovernmental Panel on Climate Change (IPCC) 2007a) and precipitation has increased nationally by 5%-10%, mostly due to an increase in heavy downpours (NAO 2000). There is a high confidence, based on substantial new evidence, that observed changes in marine systems are associated with rising water temperatures, as well as related changes in ice cover, salinity, oxygen levels, and circulation. Ocean acidification resulting from massive amounts of carbon dioxide and other pollutants released into the air can have major adverse impacts on the calcium balance in the oceans. Changes to the marine ecosystem due to climate change include shifts in ranges and changes in algal, plankton, and fish abundance (IPCC 2007b); these trends are most apparent over the past few decades. Information on future impacts of climate change in the action area is discussed below.

Climate model projections exhibit a wide range of plausible scenarios for both temperature and precipitation over the next century. Both of the principal climate models used by the National Assessment Synthesis Team (NAST) project warming in the southeast by the 2090s, but at different rates (NAST 2000): the Canadian model scenario shows the southeast U.S. experiencing a high degree of warming, which translates into lower soil moisture as higher temperatures increase evaporation; the Hadley model scenario projects less warming and a significant increase in precipitation (about 20%). The scenarios examined, which assume no major interventions to reduce continued growth of world greenhouse gases (GHG), indicate that temperatures in the U.S. will rise by about 3°-5°C (5°-9°F) on average in the next 100 years which is more than the projected global increase (NAST 2000). A warming of about 0.2°C (0.4°F) per decade is projected for the next two decades over a range of emission scenarios (IPCC 2007). This temperature increase will very likely be associated with more extreme precipitation and faster evaporation of water, leading to greater frequency of both very wet and very dry conditions. Climate warming has resulted in increased precipitation, river discharge, and glacial and sea-ice melting (Greene *et al.* 2008).

The past three decades have witnessed major changes in ocean circulation patterns in the Arctic, and these were accompanied by climate associated changes as well (Greene *et al.* 2008). Shifts in atmospheric conditions have altered Arctic Ocean circulation patterns and the export of freshwater to the North Atlantic (Greene *et al.* 2008, IPCC 2006). With respect specifically to the North Atlantic Oscillation (NAO), changes in salinity and temperature are thought to be the result of changes in the earth's atmosphere caused by anthropogenic forces (IPCC 2006). The NAO impacts climate variability throughout the northern hemisphere (IPCC 2006). Data from the 1960s through the present show that the NAO index has increased from minimum values in the 1960s to strongly positive index values in the 1990s and somewhat declined since (IPCC 2006). This warming extends over 1000m (0.62 miles) deep and is deeper than anywhere in the world oceans and is particularly evident under the Gulf Stream/ North Atlantic Current system (IPCC 2006). On a global scale, large discharges of freshwater into the North Atlantic subarctic seas can lead to intense stratification of the upper water column and a disruption of North Atlantic Deepwater (NADW) formation (Greene *et al.* 2008, IPCC 2006). There is evidence that the NADW has already freshened significantly (IPCC 2006). This in turn can lead to a slowing down of the global ocean thermohaline (large-scale circulation in the ocean that transforms low-density upper ocean waters to higher density intermediate and deep waters and returns those waters back to the upper ocean), which can have climatic ramifications for the whole earth system (Greene *et al.* 2008).

While predictions are available regarding potential effects of climate change globally, it is more difficult to assess the potential effects of climate change over the next few decades on coastal and marine resources on smaller geographic scales, such as the Delaware River, especially as climate variability is a dominant factor in shaping coastal and marine systems. The effects of future change will vary greatly in diverse coastal regions for the U.S. Warming is very likely to continue in the U.S. over the next 25 to 50 years regardless of reduction in GHGs, due to emissions that have already occurred (NAST 2000). It is very likely that the magnitude and frequency of ecosystem changes will continue to increase in the next 25 to 50 years, and it is possible that the rate of change will accelerate. Climate change can cause or exacerbate direct stress on ecosystems through high temperatures, a reduction in water availability, and altered frequency of extreme events and severe storms. Water temperatures in streams and rivers are likely to increase as the climate warms and are very likely to have both direct and indirect effects on aquatic ecosystems. Changes in

temperature will be most evident during low flow periods when they are of greatest concern (NAST 2000). In some marine and freshwater systems, shifts in geographic ranges and changes in algal, plankton, and fish abundance are associated with high confidence with rising water temperatures, as well as related changes in ice cover, salinity, oxygen levels and circulation (IPCC 2007).

A warmer and drier climate is expected to result in reductions in stream flows and increases in water temperatures. Expected consequences could be a decrease in the amount of dissolved oxygen in surface waters and an increase in the concentration of nutrients and toxic chemicals due to reduced flushing rate (Murdoch *et al.* 2000). Because many rivers are already under a great deal of stress due to excessive water withdrawal or land development, and this stress may be exacerbated by changes in climate, anticipating and planning adaptive strategies may be critical (Hulme 2005). A warmer-wetter climate could ameliorate poor water quality conditions in places where human-caused concentrations of nutrients and pollutants other than heat currently degrade water quality (Murdoch *et al.* 2000). Increases in water temperature and changes in seasonal patterns of runoff will very likely disturb fish habitat and affect recreational uses of lakes, streams, and wetlands. Surface water resources in the southeast are intensively managed with dams and channels and almost all are affected by human activities; in some systems water quality is either below recommended levels or nearly so. A global analysis of the potential effects of climate change on river basins indicates that due to changes in discharge and water stress, the area of large river basins in need of reactive or proactive management interventions in response to climate change will be much higher for basins impacted by dams than for basins with free-flowing rivers (Palmer *et al.* 2008). Human-induced disturbances also influence coastal and marine systems, often reducing the ability of the systems to adapt so that systems that might ordinarily be capable of responding to variability and change are less able to do so. Because stresses on water quality are associated with many activities, the impacts of the existing stresses are likely to be exacerbated by climate change. Within 50 years, river basins that are impacted by dams or by extensive development may experience greater changes in discharge and water stress than unimpacted, free-flowing rivers (Palmer *et al.* 2008).

While debated, researchers anticipate: 1) the frequency and intensity of droughts and floods will change across the nation; 2) a warming of about 0.2°C (0.4°F) per decade; and 3) a rise in sea level (NAST 2000). A warmer and drier climate will reduce stream flows and increase water temperature resulting in a decrease of DO and an increase in the concentration of nutrients and toxic chemicals due to reduced flushing. Sea level is expected to continue rising: during the 20th century global sea level has increased 15 to 20 cm (6-8 inches).

7.2 Species Specific Information on Climate Change Effects

7.2.1 Loggerhead Sea Turtles

The most recent Recovery Plan for loggerhead sea turtles as well as the 2009 Status Review Report identifies global climate change as a threat to loggerhead sea turtles. However, trying to assess the likely effects of climate change on loggerhead sea turtles is extremely difficult given the uncertainty in all climate change models and the difficulty in determining the likely rate of temperature increases and the scope and scale of any accompanying habitat effects. Additionally, no significant climate change-related impacts to loggerhead sea turtle populations have been observed to date. Over the long-term, climate change related impacts are expected to influence biological trajectories

on a century scale (Parmesan and Yohe 2003). As noted in the 2009 Status Review (Conant *et al.* 2009), impacts from global climate change induced by human activities are likely to become more apparent in future years (IPCC 2007). Climate change related increasing temperatures, sea level rise, changes in ocean productivity, and increased frequency of storm events may affect loggerhead sea turtles.

Increasing temperatures are expected to result in increased polar melting and changes in precipitation which may lead to rising sea levels (Titus and Narayanan 1995 in Conant *et al.* 2009), which could result in increased erosion rates along nesting beaches. Sea level rise could result in the inundation of nesting sites and decrease available nesting habitat (Daniels *et al.* 1993; Fish *et al.* 2005; Baker *et al.* 2006). The BRT noted that the loss of habitat as a result of climate change could be accelerated due to a combination of other environmental and oceanographic changes such as an increase in the frequency of storms and/or changes in prevailing currents, both of which could lead to increased beach loss via erosion (Antonelis *et al.* 2006; Baker *et al.* 2006; both in Conant *et al.* 2009). Along developed coastlines, and especially in areas where erosion control structures have been constructed to limit shoreline movement, rising sea levels may cause severe effects on nesting females and their eggs as nesting females may deposit eggs seaward of the erosion control structures potentially subjecting them to repeated tidal inundation. However, if global temperatures increase and there is a range shift northwards, beaches not currently used for nesting may become available for loggerhead sea turtles, which may offset some loss of accessibility to beaches in the southern portions of the range.

Climate change has the potential to result in changes at nesting beaches that may affect loggerhead sex ratios. Loggerhead sea turtles exhibit temperature-dependent sex determination. Rapidly increasing global temperatures may result in warmer incubation temperatures and highly female-biased sex ratios (*e.g.*, Glen and Mrosovsky 2004; Hawkes *et al.* 2009); however, to the extent that nesting can occur at beaches further north where sand temperatures are not as warm, these effects may be partially offset. The BRT specifically identified climate change as a threat to loggerhead sea turtles in the neritic/oceanic zone where climate change may result in future trophic changes, thus impacting loggerhead prey abundance and/or distribution. In the threats matrix analysis, climate change was considered for oceanic juveniles and adults and eggs/hatchlings. The report states that for oceanic juveniles and adults, “although the effect of trophic level change from...climate change...is unknown it is believed to be very low.” For eggs/hatchlings the report states that total mortality from anthropogenic causes, including sea level rise resulting from climate change, is believed to be low relative to the entire life stage. However, only limited data are available on past trends related to climate effects on loggerhead sea turtles; current scientific methods are not able to reliably predict the future magnitude of climate change, associated impacts, whether and to what extent some impacts will offset others, or the adaptive capacity of this species.

However, Van Houtan and Halley (2011) recently developed climate based models to investigate loggerhead nesting (considering juvenile recruitment and breeding remigration) in the North Pacific and Northwest Atlantic. These models found that climate conditions/oceanographic influences explain loggerhead nesting variability, with climate models alone explaining an average 60% (range 18%-88%) of the observed nesting changes over the past several decades. In terms of future nesting projections, modeled climate data show a future positive trend for Florida nesting, with increases through 2040 as a result of the Atlantic Multidecadal Oscillation signal.

7.2.2 Kemp's Ridley Sea Turtles

The recovery plan for Kemp's ridley sea turtles (NMFS *et al.* 2011) identifies climate change as a threat; however, as with the other species discussed above, no significant climate change-related impacts to Kemp's ridley sea turtles have been observed to date. Atmospheric warming could cause habitat alteration which may change food resources such as crabs and other invertebrates. It may increase hurricane activity, leading to an increase in debris in nearshore and offshore waters, which may result in an increase in entanglement, ingestion, or drowning. In addition, increased hurricane activity may cause damage to nesting beaches or inundate nests with sea water. Atmospheric warming may change convergence zones, currents and other oceanographic features that are relevant to Kemp's ridleys, as well as change rain regimes and levels of nearshore runoff.

Considering that the Kemp's ridley has temperature-dependent sex determination (Wibbels 2003) and the vast majority of the nesting range is restricted to the State of Tamaulipas, Mexico, global warming could potentially shift population sex ratios towards females and thus change the reproductive ecology of this species. A female bias is presumed to increase egg production (assuming that the availability of males does not become a limiting factor) (Coyne and Landry 2007) and increase the rate of recovery; however, it is unknown at what point the percentage of males may become insufficient to facilitate maximum fertilization rates in a population. If males become a limiting factor in the reproductive ecology of the Kemp's ridley, then reproductive output in the population could decrease (Coyne 2000). Low numbers of males could also result in the loss of genetic diversity within a population; however, there is currently no evidence that this is a problem in the Kemp's ridley population (NMFS *et al.* 2011). Models (Davenport 1997, Hulin and Guillon 2007, Hawkes *et al.* 2007, all referenced in NMFS *et al.* 2011) predict very long-term reductions in fertility in sea turtles due to climate change, but due to the relatively long life cycle of sea turtles, reductions may not be seen until 30 to 50 years in the future.

Another potential impact from global climate change is sea level rise, which may result in increased beach erosion at nesting sites. Beach erosion may be accelerated due to a combination of other environmental and oceanographic changes such as an increase in the frequency of storms and/or changes in prevailing currents. In the case of the Kemp's ridley where most of the critical nesting beaches are undeveloped, beaches may shift landward and still be available for nesting. The Padre Island National Seashore (PAIS) shoreline is accreting, unlike much of the Texas coast, and with nesting increasing and the sand temperatures slightly cooler than at Rancho Nuevo, PAIS could become an increasingly important source of males for the population.

7.2.3 Green Sea Turtles

The five year status review for green sea turtles (NMFS and USFWS 2007d) notes that global climate change is affecting green sea turtles and is likely to continue to be a threat. There is an increasing female bias in the sex ratio of green turtle hatchlings. While this is partly attributable to imperfect egg hatchery practices, global climate change is also implicated as a likely cause. This is because warmer sand temperatures at nesting beaches are likely to result in the production of more female embryos. At least one nesting site, Ascension Island, has had an increase in mean sand temperature in recent years (Hays *et al.* 2003 in NMFS and USFWS 2007d). Climate change may also affect nesting beaches through sea level rise, which may reduce the availability of nesting habitat and increase the risk of nest inundation. Loss of appropriate nesting habitat may also be

accelerated by a combination of other environmental and oceanographic changes, such as an increase in the frequency of storms and/or changes in prevailing currents, both of which could lead to increased beach loss via erosion. Oceanic changes related to rising water temperatures could result in changes in the abundance and distribution of the primary food sources of green sea turtles, which in turn could result in changes in behavior and distribution of this species. Seagrass habitats may suffer from decreased productivity and/or increased stress due to sea level rise, as well as salinity and temperature changes (Short and Neckles 1999; Duarte 2002).

As noted above, the increasing female bias in green sea turtle hatchlings is thought to be at least partially linked to increases in temperatures at nesting beaches. However, at this time, we do not know how much of this bias is due to hatchery practice and how much is due to increased sand temperature. Because we do not have information to predict the extent and rate to which sand temperatures at the nesting beaches used by green sea turtles may increase in the short-term future, we cannot predict the extent of any future bias. Also, we do not know to what extent to which green sea turtles may be able to cope with this change by selecting cooler areas of the beach or shifting their nesting distribution to other beaches at which increases in sand temperature may not be experienced.

7.2.4 Leatherback sea turtles

Global climate change has been identified as a factor that may affect leatherback habitat and biology (NMFS and USFWS 2007b); however, no significant climate change related impacts to leatherback sea turtle populations have been observed to date. Over the long term, climate change related impacts will likely influence biological trajectories in the future on a century scale (Parmesan and Yohe 2003). Changes in marine systems associated with rising water temperatures, changes in ice cover, salinity, oxygen levels and circulation including shifts in ranges and changes in algal, plankton, and fish abundance could affect leatherback prey distribution and abundance. Climate change is expected to expand foraging habitats into higher latitude waters and some concern has been noted that increasing temperatures may increase the female:male sex ratio of hatchlings on some beaches (Morosovsky *et al.* 1984 and Hawkes *et al.* 2007 in NMFS and USFWS 2007b). However, due to the tendency of leatherbacks to have individual nest placement preferences and deposit some clutches in the cooler tide zone of beaches, the effects of long-term climate on sex ratios may be mitigated (Kamel and Mrosovsky 2004 in NMFS and USFWS 2007b).

Additional potential effects of climate change on leatherbacks include range expansion and changes in migration routes as increasing ocean temperatures shift range-limiting isotherms north (Robinson *et al.* 2008). Leatherbacks have expanded their range in the Atlantic north by 330 km in the last 17 years as warming has caused the northerly migration of the 15°C sea surface temperature (SST) isotherm, the lower limit of thermal tolerance for leatherbacks (McMahon and Hays 2006). Leatherbacks are speculated to be the best able to cope with climate change of all the sea turtle species due to their wide geographic distribution and relatively weak beach fidelity. Leatherback sea turtles may be most affected by any changes in the distribution of their primary jellyfish prey, which may affect leatherback distribution and foraging behavior (NMFS and USFWS 2007b). Jellyfish populations may increase due to ocean warming and other factors (Brodeur *et al.* 1999; Attrill *et al.* 2007; Richardson *et al.* 2009). However, any increase in jellyfish populations may or may not impact leatherbacks as there is no evidence that any leatherback populations are currently food-limited.

Increasing temperatures are expected to result in increased polar melting and changes in precipitation which may lead to rising sea levels (Titus and Narayanan 1995 in Conant *et al.* 2009), which could result in increased erosion rates along nesting beaches. Sea level rise could result in the inundation of nesting sites and decrease available nesting habitat (Fish *et al.* 2005). This effect would potentially be accelerated due to a combination of other environmental and oceanographic changes such as an increase in the frequency of storms and/or changes in prevailing currents. While there is a reasonable degree of certainty that climate change related effects will be experienced globally (*e.g.*, rising temperatures and changes in precipitation patterns), due to a lack of scientific data, the specific effects of climate change on this species are not quantifiable at this time (Hawkes *et al.* 2009).

7.2.5 Atlantic sturgeon

Global climate change may affect all DPSs of Atlantic sturgeon in the future; however, effects of increased water temperature and decreased water availability are most likely to effect the South Atlantic and Carolina DPSs. Rising sea level may result in the salt wedge moving upstream in affected rivers. Atlantic sturgeon spawning occurs in fresh water reaches of rivers because early life stages have little to no tolerance for salinity. Similarly, juvenile Atlantic sturgeon have limited tolerance to salinity and remain in waters with little to no salinity. If the salt wedge moves further upstream, Atlantic sturgeon spawning and rearing habitat could be restricted. In river systems with dams or natural falls that are impassable by sturgeon, the extent that spawning or rearing may be shifted upstream to compensate for the shift in the movement of the saltwedge would be limited. While there is an indication that an increase in sea level rise would result in a shift in the location of the salt wedge, at this time there are no predictions on the timing or extent of any shifts that may occur; thus, it is not possible to predict any future loss in spawning or rearing habitat. However, in all river systems, spawning occurs miles upstream of the saltwedge. It is unlikely that shifts in the location of the saltwedge would eliminate freshwater spawning or rearing habitat. If habitat was severely restricted, productivity or survivability may decrease.

The increased rainfall predicted by some models in some areas may increase runoff and scour spawning areas and flooding events could cause temporary water quality issues. Rising temperatures predicted for all of the U.S. could exacerbate existing water quality problems with DO and temperature. While this occurs primarily in rivers in the southeast U.S. and the Chesapeake Bay, it may start to occur more commonly in the northern rivers. Atlantic sturgeon prefer water temperatures up to approximately 28°C (82.4°F); these temperatures are experienced naturally in some areas of rivers during the summer months. If river temperatures rise and temperatures above 28°C are experienced in larger areas, sturgeon may be excluded from some habitats.

Increased droughts (and water withdrawal for human use) predicted by some models in some areas may cause loss of habitat including loss of access to spawning habitat. Drought conditions in the spring may also expose eggs and larvae in rearing habitats. If a river becomes too shallow or flows become intermittent, all Atlantic sturgeon life stages, including adults, may become susceptible to strandings or habitat restriction. Low flow and drought conditions are also expected to cause additional water quality issues. Any of the conditions associated with climate change are likely to disrupt river ecology causing shifts in community structure and the type and abundance of prey. Additionally, cues for spawning migration and spawning could occur earlier in the season causing a

mismatch in prey that are currently available to developing sturgeon in rearing habitat.

7.3 Effects of Climate Change in the Action Area

In 2008, the Chesapeake Bay Program's Scientific and Technical Advisory Committee (STAC) reviewed the current understanding of climate change impacts on the tidal Chesapeake Bay and identified critical knowledge gaps and research priorities (Pyke et al. 2008). The report notes that the Bay is sensitive to climate-related forcings of atmospheric CO₂ concentration, sea level, temperature, precipitation, and storm frequency and intensity and that scientists have detected significant warming and sea-level-rise trends during the 20th century in the Chesapeake Bay. Climate change scenarios for CO₂ emissions examined by STAC suggest that the region is likely to experience significant changes in climatic conditions throughout the 21st century including increases in CO₂ concentrations, sea level rise of 0.7 to 1.6 meters, and water temperature increasing by up to 2° to 6°C. The STAC also indicated that other changes are likely, but less certain, including increases in precipitation quantity (particularly in winter and spring), precipitation intensity, intensity of tropical and extratropical cyclones (though their frequency may decrease), and sea-level variability. Changes in annual streamflow are highly uncertain, though winter and spring flows will likely increase. The report notes that changes in human activities over the next century have the potential to either exacerbate or ameliorate the predicted climatically induced changes. Given the uncertainty in precipitation and streamflow forecasts, the direction of some changes remains unknown; however, the report states that certain consequences appear likely including increasing sea level in the Bay: increasing variability in salinity due to increases in precipitation intensity, drought, and storminess; more frequent blooms of harmful algae due to warming and higher CO₂ concentrations; potential decreases in the prevalence of eelgrass; possible increases in hypoxia due to warming and greater winter-spring streamflow; and, altered interactions among trophic levels, potentially favoring warm-water fish and shellfish species in the Bay.

In 2010, EPA conducted a preliminary assessment of climate change impacts on the Chesapeake Bay using a version of the Phase 5 Bay Watershed Model and tools developed for EPA's BASINS 4 system including the Climate Assessment Tool. Flows and associated nutrient and sediment loads were assessed in all river basins of the Chesapeake Bay with three key climate change scenarios reflecting the range of potential changes in temperature and precipitation in the year 2030. The three key scenarios came from a larger set of 42 climate change scenarios that were evaluated from 7 Global Climate Models, 2 scenarios from the IPCC Special Report on Emissions Scenarios storylines, and 3 assumptions about precipitation intensity in the largest events. The 42 climate change scenarios were run on the Phase 5 Watershed Model of the Monocacy River watershed, a subbasin of the Potomac River basin in the Piedmont region, using a 2030 estimated land use based on a sophisticated land use model containing socioeconomic estimates of development throughout the watershed.

The results provide an indication of likely precipitation and flow patterns under future potential climate conditions (Linker et al. 2007, 2008). Projected temperature increases tend to increase evapotranspiration in the Bay watershed, effectively offsetting increases in precipitation. The preliminary analysis indicated overall decreases in annual stream flow as well as decreases in nitrogen and phosphorus loads. The higher intensity precipitation events yielded estimated increases in annual sediment loads.

Assuming that there is a linear trend in increasing water temperatures, and that a predicted 2-6°C increase in water temperature by 2100 for the Chesapeake Bay would also be experienced in the action area, one could anticipate a 0.02-.07°C increase each year. Because the action considered here will be complete within one year, we expect an increase in temperature of no more than 0.07°C in the action area over the duration of the proposed action.

7.4 Effects of Climate Change in the Action Area to Atlantic sturgeon

As there is significant uncertainty in the rate and timing of change as well as the effect of any changes that may be experienced in the action area due to climate change, it is difficult to predict the impact of these changes on Atlantic sturgeon; however, we have considered the available information to consider likely impacts to sturgeon in the action area. The proposed action under consideration will take place in 2012-2013; thus, we consider here, likely effects of climate change during that period.

Over time, the most likely effect to Atlantic sturgeon would be if sea level rise was great enough to consistently shift the salt wedge far enough north in spawning river which would restrict the range of juvenile sturgeon and may affect the development of these life stages. However, there are no spawning rivers in the action area (the nearest is the James River, maintenance of which is not considered in this Opinion).

In the action area, it is possible that changing seasonal temperature regimes could result in changes in the timing of seasonal migrations through the area as sturgeon move throughout the area. There could be shifts in the timing of spawning; presumably, if water temperatures warm earlier in the spring, and water temperature is a primary spawning cue, spawning migrations and spawning events could occur earlier in the year. However, because spawning is not triggered solely by water temperature, but also by day length (which would not be affected by climate change) and river flow (which could be affected by climate change), it is not possible to predict how any change in water temperature or river flow by itself will affect the seasonal movements of sturgeon through the action area. However, it seems most likely that spawning would shift earlier in the year.

Any forage species that are temperature dependent may also shift in distribution as water temperatures warm. However, because we do not know the adaptive capacity of these individuals or how much of a change in temperature would be necessary to cause a shift in distribution, it is not possible to predict how these changes may affect foraging sturgeon. If sturgeon distribution shifted along with prey distribution, it is likely that there would be minimal, if any, impact on the availability of food. Similarly, if sturgeon shifted to areas where different forage was available and sturgeon were able to obtain sufficient nutrition from that new source of forage, any effect would be minimal. The greatest potential for effect to forage resources would be if sturgeon shifted to an area or time where insufficient forage was available; however, the likelihood of this happening seems low because sturgeon feed on a wide variety of species and in a wide variety of habitats.

Limited information on the thermal tolerances of Atlantic sturgeon is available. Atlantic sturgeon have been observed in water temperatures above 30°C in the south (see Damon-Randall *et al.* 2010). In the laboratory, juvenile Atlantic sturgeon showed negative behavioral and bioenergetics responses (related to food consumption and metabolism) after prolonged exposure to temperatures greater than 28°C (82.4°F) (Niklitschek 2001). Tolerance to temperatures is thought to increase

with age and body size (Ziegweid *et al.* 2008 and Jenkins *et al.* 1993), however, no information on the lethal thermal maximum or stressful temperatures for subadult or adult Atlantic sturgeon is available. Shortnose sturgeon, have been documented in the lab to experience mortality at temperatures of 33.7°C (92.66°F) or greater and are thought to experience stress at temperatures above 28°C. For purposes of considering thermal tolerances, we consider Atlantic sturgeon to be a reasonable surrogate for shortnose sturgeon given similar geographic distribution and known biological similarities.

Mean monthly ambient temperatures in the Chesapeake Bay range from 2-26°C⁷. As explained above, available predictions estimate an increase in ambient water temperature in the Bay of 0.07°C over the duration of the proposed action. This increase is extremely unlikely to affect the distribution or behavior of Atlantic sturgeon in the action area.

As described above, over the long term, global climate change may affect Atlantic sturgeon by affecting the location of the salt wedge, distribution of prey, water temperature and water quality. However, given the short duration of the proposed action, it is extremely unlikely that any of these potential effects will be experienced during the time period considered here.

7.5 Effects of Climate Change in the Action Area on Sea Turtles

As there is significant uncertainty in the rate and timing of change as well as the effect of any changes that may be experienced in the action area due to climate change, it is difficult to predict the impact of these changes on sea turtles; however, we have considered the available information to consider likely impacts to these species in the action area.

Sea turtles are most likely to be affected by climate change due to increasing sand temperatures at nesting beaches which in turn would result in increased female: male sex ratio among hatchlings, sea level rise which could result in a reduction in available nesting beach habitat, increased risk of nest inundation, changes in the abundance and distribution of forage species which could result in changes in the foraging behavior and distribution of sea turtle species, and changes in water temperature which could possibly lead to a northward shift in their range.

Over the time period considered in this Opinion (i.e., through 2013), any rise in sea surface temperature is expected to be extremely small (a fraction of a degree, if that). It is extremely unlikely that any change in water temperature in this period would be enough to contribute to shifts in the range or distribution of sea turtles. Theoretically we expect that as waters in the action area warm, more sea turtles could be present or sea turtles could be present for longer periods of time. However, if temperature affected the distribution of sea turtle forage in a way that decreased forage in the action area, sea turtles may be less likely to occur in the action area.

It has been speculated that the nesting range of some sea turtle species may shift northward as ambient water temperatures rise. Nesting in Virginia is relatively rare, but a small number of loggerhead nests are laid on Virginia Beach and other ocean facing beaches each year. The maximum number of nests laid in Virginia in a particular year was nine. As of the end of July 2012, seven loggerhead nests have been recorded and one Kemp's ridley nest (at Dam Neck); the first time a Kemp's ridley nest has ever been documented in Virginia and the furthest north this

⁷ Information obtained from www.nodc.noaa.gov/dsdt/cwtg/satl.html; last accessed 7-25-12.

species has ever been documented to nest. It is important to consider that in order for nesting to be successful in the mid-Atlantic, fall and winter temperatures need to be warm enough to support the successful rearing of eggs and sea temperatures must be warm enough for hatchlings not to die when they enter the water. As noted above, it is extremely unlikely that any effects of global climate change would be experienced within the period that this action will be completed and any change that is experienced is not likely to be great enough to influence sea turtle nesting behavior in the action area.

8.0 EFFECTS OF THE ACTION

This section of an Opinion assesses the direct and indirect effects of the proposed action on threatened and endangered species or critical habitat, together with the effects of other activities that are interrelated or interdependent (50 CFR 402.02). Indirect effects are those that are caused later in time, but are still reasonably certain to occur. Interrelated actions are those that are part of a larger action and depend upon the larger action for their justification. Interdependent actions are those that have no independent utility apart from the action under consideration (50 CFR 402.02). We have not identified any interdependent or interrelated actions. This Opinion examines the likely effects (direct and indirect) of the proposed action on five DPSs of Atlantic sturgeon and sea turtles in the action area and their habitat within the context of the species current status, the environmental baseline and cumulative effects. As explained in the Description of the Action, the action under consideration in this Opinion is dredging in Sandbridge Shoals for beach nourishment and hurricane protection, as scheduled to occur from 2012-2013. The work will be carried out with a hopper or cutterhead dredge.

The effects of dredging on listed species will be different depending on the type of dredge used. As such, the following discussion of effects of dredging will be organized by dredge type. Below, the discussion will consider the effects of dredging, including the risk of entrainment or capture of Atlantic sturgeon and sea turtles. We also consider effects of dredging and disposal on water quality, including turbidity/suspended sediment. Last, there is a discussion of other effects that are not specific to the type of equipment used. This includes effects on prey and foraging, changes in the characteristics of the dredged area and effects of dredge vessel traffic.

8.1 Hopper Dredge

Hopper dredges are self-propelled seagoing vessels that are equipped with propulsion machinery, sediment containers (hoppers), dredge pumps, and trailing suction drag-heads required to perform their essential function of excavating sediments from the channel bottom. Hopper dredges have propulsion power adequate for required free-running speed and dredge against strong currents. They also have excellent maneuverability. This allows hopper dredges to provide a safe working environment for crew and equipment dredging bar channels or other areas subject to rough seas. Hopper dredges also are more practicable when interference with vessel traffic must be minimized.

A hopper dredge removes material from the bottom of the channel in relatively thin layers, usually 2-12 inches, depending upon the density and cohesiveness of the dredged material. Pumps located within the hull, but sometimes mounted on the drag arm, create a region of low pressure around the dragheads and forces water and sediment up the drag arm and into the hopper. The more closely the draghead is maintained in contact with the sediment, the more efficient the dredging providing sufficient water is available to slurry the sediments (i.e. the greater the concentration of slurried

sediment pumped into the hopper). Hopper dredges can efficiently dredge non-cohesive sands and more cohesive silts and low density clay. Draghead types may consist of IHC and California type dragheads.

California type dragheads sit flatter in the sediment than the IHC configuration which is more upright. Individual draghead designs (i.e. dimensions, structural reinforcing/configuration...) vary between dredging contractors and hopper vessels. Port openings on the bottom of dragheads also vary between contractors and draghead design. Generally speaking the port geometry is typically rectangular or square with minimum openings of ten inch by ten inch or twelve inch by twelve inch or some rectangular variation.

Industry and government hopper dredges are equipped with various power and pump configurations and may differ in hopper capacity with different dredging capabilities. An engineering analysis of the known hydraulic characteristics of the pump and pipeline system on the USACE hopper dredge “Essayons” (i.e. a 6,423 cy hopper dredge) indicates an operational flow rate of forty cubic feet per second with a flow velocity of eleven feet per second at the draghead port openings. The estimated force exerted on a one-foot diameter turtle (i.e. one foot diameter disc shaped object) at the pump operational point in this system was estimated to be twenty-eight pounds of suction or drag force on the object at the port opening of the draghead.

Dredging is typically parallel to the centerline or axis of the channel. Under certain conditions, a waffle or crisscross pattern may be utilized to minimize trenching or during clean-up dredging operations to remove ridges and produce a more level channel bottom. This movement up and down the channel while dredging is called trailing and may be accomplished at speeds of 1-3 knots, depending on the shoaling, sediment characteristics, sea conditions, and numerous other factors. In the hopper, the slurry mixture of the sediment and water is managed by a weir system to settle out the dredged material solids and overflow the supernatant water. When an economic load is achieved, the vessel suspends dredging, the drag arms are raised, and the dredge travels to the designated placement site. Because dredging stops during the trip to the placement site, the overall efficiency of the hopper dredge is dependent on the distance between the dredging location and placement sites; the more distant to the placement site, the less efficient the dredging operation resulting in longer contract periods to accomplish the work.

Sea turtle deflectors utilized on hopper dredges are rigid V-shaped attachments on the front of the dragheads and are designed and intended to plow the sediment in front of the draghead. The plowing action creates a sand wave that rolls in front of the deflector. The propagated sand wave is intended to shed the turtle away from the deflector and out of the path of the draghead. The effectiveness of the rigid deflector design and its ability to reduce entrainment was studied by the USACE through model and field testing during the 1980s and early 1990s. The deflectors are most effective when operating on a uniform or flat bottom. However, the deflector effectiveness may be diminished when significant ridges and troughs are present that prevent the deflector from plowing and maintaining the sand wave and the dragheads from maintaining firm contact with the channel bottom.

8.1.1 Entrainment in Hopper Dredges – Sea Turtles

As outlined above, sea turtles are likely to occur in Chesapeake Bay from April through mid-

November each year with the largest numbers present from June through October of any year. The majority of sea turtles in the Chesapeake bay are juvenile loggerheads; however, adult loggerheads, juvenile Kemp's ridley, adult and juvenile leatherback and adult green sea turtles have also been documented in the area. The Chesapeake Bay is an important foraging area for sea turtles and an important developmental habitat for juvenile sea turtles, particularly loggerheads.

Loggerhead, Kemp's ridley and green sea turtles are vulnerable to entrainment in the draghead of the hopper dredge. Given their large size, leatherback sea turtles are not vulnerable to entrainment. As reported by USACE, no leatherback sea turtles have been entrained in hopper dredge operations operating along the U.S. Atlantic coast (USACE Sea Turtle Warehouse, 2012). Sea turtles are likely to be feeding on or near the bottom of the water column during the warmer months, with loggerhead and Kemp's ridley sea turtles being the most common species in these waters. Although not expected to be as numerous as loggerheads and Kemp's ridleys, green sea turtles are also likely to occur seasonally in the Bay.

Sea turtles become entrained in hopper dredges as the draghead moves along the bottom. Entrainment occurs when sea turtles do not or cannot escape from the suction of the dredge. Sea turtles can also be crushed on the bottom by the moving draghead. Mortality most often occurs when turtles are sucked into the dredge draghead, pumped through the intake pipe and then killed as they cycle through the centrifugal pump and into the hopper. Because entrainment is believed to occur primarily while the draghead is operating on the bottom, it is likely that only those species feeding or resting on or near the bottom would be vulnerable to entrainment. Turtles can also be entrained if suction is created in the draghead by current flow while the device is being placed or removed, or if the dredge is operating on an uneven or rocky substrate and rises off the bottom. Recent information from the USACE suggests that the risk of entrainment is highest when the bottom terrain is uneven or when the dredge is conducting "clean up" operations at the end of a dredge cycle when the bottom is trenched and the dredge is working to level out the bottom. In these instances, it is difficult for the dredge operator to keep the draghead buried in the sand and sea turtles near the bottom may be more vulnerable to entrainment. Increased risk of entrainment in these conditions may also be related to reduced effectiveness of the turtle deflector when operating on uneven terrain.

Sea turtles have been found resting in deeper waters, which could increase the likelihood of interactions from dredging activities. In 1981, observers documented the take of 71 loggerheads by a hopper dredge at the Port Canaveral Ship Channel, Florida (Slay and Richardson 1988). This channel is a deep, low productivity environment in the Southeast Atlantic where sea turtles are known to rest on the bottom, making them extremely vulnerable to entrainment. The large number of turtle mortalities at the Port Canaveral Ship Channel in the early 1980s resulted in part from turtles being buried in the soft bottom mud, a behavior known as brumation. Since 1981, 77 loggerhead sea turtles have been taken by hopper dredge operations in the Port Canaveral Ship Channel, Florida. Chelonid turtles have been found to make use of deeper, less productive channels as resting areas that afford protection from predators because of the low energy, deep water conditions. Sea turtle brumation has not been documented in the Chesapeake Bay.

8.1.1.1 Background Information on Entrainment of Sea Turtles in Hopper Dredges

Sea turtles have been killed in hopper dredge operations along the East and Gulf coasts of the US.

Documented turtle mortalities during dredging operations in the USACE South Atlantic Division (SAD; i.e., south of the Virginia/North Carolina border) are more common than in the USACE North Atlantic Division (NAD; Virginia-Maine) presumably due to the greater abundance of turtles in these waters and the greater frequency of hopper dredge operations. For example, in the USACE SAD, over 400 sea turtles have been entrained in hopper dredges since 1980 and in the Gulf Region over 160 sea turtles have been killed since 1995. Records of sea turtle entrainment in the USACE NAD began in 1994. Through July 2012, 74 sea turtles deaths (see Table 6) related to hopper dredge activities have been recorded in waters north of the North Carolina/Virginia border (USACE Sea Turtle Database⁸); 64 of these turtles have been entrained in dredges operating in Chesapeake Bay.

Before 1994, endangered species observers were not required on board hopper dredges and dredge baskets were not inspected for sea turtles or sea turtle parts. The majority of sea turtle takes in the NAD have occurred in the Norfolk district. This is largely a function of the large number of loggerhead and Kemp’s ridley sea turtles that occur in the Chesapeake Bay each summer and the intense dredging operations that are conducted to maintain the Chesapeake Bay entrance channels and for beach nourishment projects at Virginia Beach. Since 1992, the take of 10 sea turtles (all loggerheads) has been recorded during hopper dredge operations in the Philadelphia, Baltimore and New York Districts. Hopper dredging is relatively rare in New England waters where sea turtles are known to occur, with most hopper dredge operations being completed by the specialized Government owned dredge Currituck which operates at low suction and has been demonstrated to have a very low likelihood of entraining or impinging sea turtles. To date, no hopper dredge operations (other than the Currituck) have occurred in the New England District in areas or at times when sea turtles are likely to be present.

Table 6. Sea Turtle Takes in USACE NAD Dredging Operations

Project Location	Year of Operation	Cubic Yardage Removed	Observed Takes
Cape Henry Channel	2012	1,190,004	1 loggerhead
York Spit	2012	145,332	1 Loggerhead
Thimble Shoal Channel	2009	473,900	3 Loggerheads
York Spit	2007	608,000	1 Kemp’s Ridley
Cape Henry	2006	447,238	3 Loggerheads
Thimble Shoal Channel	2006	300,000	1 loggerhead
Delaware Bay	2005	50,000	2 Loggerheads
Thimble Shoal Channel	2003	1,828,312	7 Loggerheads 1 Kemp’s ridley 1 unknown

⁸ The USACE Sea Turtle Data Warehouse is maintained by the USACE’s Environmental Laboratory and contains information on USACE dredging projects conducted since 1980 with a focus on information on interactions with sea turtles.

Cape Henry	2002	1,407,814	6 Loggerheads 1 Kemp's ridley 1 green
VA Beach Hurricane Protection Project (Cape Henry)	2002	1,407,814	1 Loggerhead
York Spit Channel	2002	911,406	8 Loggerheads 1 Kemp's ridley
Cape Henry	2001	1,641,140	2 loggerheads 1 Kemp's ridley
VA Beach Hurricane Protection Project (Thimble Shoals)	2001	4,000,000	5 loggerheads 1 unknown
Thimble Shoal Channel	2000	831,761	2 loggerheads 1 unknown
York River Entrance Channel	1998	672,536	6 loggerheads
Atlantic Coast of NJ	1997	1,000,000	1 Loggerhead
Thimble Shoal Channel	1996	529,301	1 loggerhead
Delaware Bay	1995	218,151	1 Loggerhead
Cape Henry	1994	552,671	4 loggerheads 1 unknown
York Spit Channel	1994	61,299	4 loggerheads
Delaware Bay	1994	NA	1 Loggerhead
Cape May NJ	1993	NA	1 Loggerhead
Off Ocean City MD	1992	1,592,262	3 Loggerheads
			<i>TOTAL = 74 Turtles</i>

It should be noted that the observed takes may not be representative of all the turtles killed during dredge operations. Typically, endangered species observers are required to observe a total of 50% of the dredge activity (i.e., 6 hours on watch, 6 hours off watch). As such, if the observer was off watch or the cage was emptied and not inspected or the dredge company either did not report or was unable to identify the turtle incident, there is the possibility that a turtle could be taken by the dredge and go unnoticed. Additionally, in older Opinions (i.e., prior to 1995), NMFS frequently only required 25% observer coverage and monitoring of the overflows which has since been determined to not be as effective as monitoring of the intakes. These conditions may have led to sea turtle takes going undetected.

NMFS raised this issue to the USACE Norfolk District during the 2002 season, after several turtles were taken in the Cape Henry and York Spit Channels, and expressed the need for 100% observer coverage. On September 30, 2002, the USACE informed the dredge contractor that when the observer was not present, the cage should not be opened unless it is clogged. This modification was to ensure that any sea turtles that were taken and on the intake screen (or in the cage area) would remain there until the observer evaluated the load. The USACE's letter further stated "Crew members will only go into the cage and remove wood, rocks, and man-made debris; any aquatic

biological material is left in the cage for the observer to document and clear out when they return on duty. In addition, the observer is the only one allowed to clean off the overflow screen. This practice provides us with 100% observation coverage and shall continue.” Theoretically, all sea turtle parts were observed under this scheme, but the frequency of clogging in the cage is unknown at this time. The most effective way to ensure that 100% observer coverage is attained is to have a NMFS-approved endangered species observer monitoring all loads at all times. This level of observer coverage would document all turtle interactions and better quantify the impact of dredging on turtle populations. More recently issued Opinions have required 100% observer coverage which increases the likelihood of takes being detected and reported.

It is likely that not all sea turtles killed by dredges are observed onboard the hopper dredge. Several sea turtles stranded on Virginia shores with crushing type injuries from May 25 to October 15, 2002. The Virginia Marine Science Museum (VMSM) found 10 loggerheads, 2 Kemp’s ridleys, and 1 leatherback exhibiting injuries and structural damage consistent with what they have seen in animals that were known dredge takes. While it cannot be conclusively determined that these strandings were the result of dredge interactions, the link is possible given the location of the strandings (e.g., in the southern Chesapeake Bay near ongoing dredging activity), the time of the documented strandings in relation to dredge operations, the lack of other ongoing activities which may have caused such damage, and the nature of the injuries (e.g., crushed or shattered carapaces and/or flipper bones, black mud in mouth). Additionally, in 1992, three dead sea turtles were found on an Ocean City, Maryland beach while dredging operations were ongoing at a borrow area located 3 miles offshore. Necropsy results indicate that the deaths of all three turtles were dredge related. It is unknown if turtles observed on the beach with these types of injuries were crushed by the dredge and subsequently stranded on shore or whether they were entrained in the dredge, entered the hopper and then were discharged onto the beach with the dredge spoils.

A dredge could crush an animal as it was setting the draghead on the bottom, or if the draghead was lifting on and off the bottom due to uneven terrain, but the actual cause of these crushing injuries cannot be determined at this time. Further analyses need to be conducted to better understand the link between crushed strandings and dredging activities, and if those strandings need to be factored into an incidental take level. Regardless, it is possible that dredges are taking animals that are not observed on the dredge which may result in strandings on nearby beaches.

Due to the nature of interactions between listed species and dredge operations, it is difficult to predict the number of interactions that are likely to occur from a particular dredging operation. Projects that occur in an identical location with the same equipment year after year may result in interactions in some years and none in other years as noted in the examples of sea turtle takes above. Dredging operations may go on for months, with sea turtle takes occurring intermittently throughout the duration of the action. For example, dredging occurred at Cape Henry over 160 days in 2002 with 8 sea turtle takes occurring over 3 separate weeks while dredging at York Spit in 1994 resulted in 4 sea turtle takes in one week. In Delaware Bay, dredge cycles have been conducted during the May-November period with no observed entrainment and as many as two sea turtles have been entrained in as little as three weeks. Even in locations where thousands of sea turtles are known to be present (i.e., Chesapeake Bay) and where dredges are operating in areas with preferred sea turtle depths and forage items (as evidenced by entrainment of these species in the dredge), the numbers of sea turtles entrained is an extremely small percentage of the likely number of sea turtles

in the action area. This is likely due to the distribution of individuals throughout the action area, the relatively small area which is affected at any given moment and the ability of some sea turtles to avoid the dredge even if they are in the immediate area.

The number of interactions between dredge equipment and sea turtles seems to be best associated with the volume of material removed, which is closely correlated to the length of time dredging takes, with a greater number of interactions associated with a greater volume of material removed and a longer duration of dredging. The number of interactions is also heavily influenced by the time of year dredging occurs (with more interactions correlated to times of year when more sea turtles are present in the action area) and the type of dredge plant used (sea turtles are apparently capable of avoiding pipeline and mechanical dredges as no takes of sea turtles have been reported with these types of dredges). The number of interactions may also be influenced by the terrain in the area being dredged, with interactions more likely when the draghead is moving up and off the bottom frequently. Interactions are also more likely at times and in areas when sea turtle forage items are concentrated in the area being dredged, as sea turtles are more likely to be spending time on the bottom while foraging.

We have compiled a dataset representing all of the hopper dredge projects in the Norfolk District that have reported the cubic yardage removed as well as the number of takes observed. The table below includes records for all projects and indicates the volume of material removed during “sea turtle season” (i.e., April - November) in the Norfolk District since 1994.

Table 7. Projects in Norfolk District since 1994

Project Location	Dredging Dates	CY of Material Removed	% during sea turtle season	Volume Removed during turtle season	total sea turtles	log	KR	green	unknown
Cape Henry Channel	1/29/12 - 4/12/12	1,190,004	16.2	192,780.65	1	1	0	0	0
York Spit	3/1/12 - 3/8/12, 4/3/12 - 4/5/2012	145,332	20.0	29,066.40	1	1	0	0	0
Cape Henry Channel	2/9/11-5/10/11	957,996	44.4	425,350.22	0	0	0	0	0
York Spit	1/9/11-4/24/11	1,503,517	15.3	230,038.10	0	0	0	0	0
Thimble Shoals	12/19/10-2/27/11; 4/19/11-4/21/11	368,104	0.000	-	0	0	0	0	0

Thimble Shoals	4/4/09-5/20/09	370,412	100.0	370,412.00	3	3	0	0	0
York Spit	6/18/07-7/03/07; 7/13/07-08/05/07	415,626	100.0	415,626.00	1	0	1	0	0
Atlantic Ocean Channel (Deepening)	12/24/05-04/8/06; 4/16/06-4/19/06	1,185,436	10.9	129,212.52	0	0	0	0	0
Cape Henry Channel	6/15/06-7/21/06	447,238	100.0	447,238.00	3	3	0	0	0
Thimble Shoal Channel	6/13/06-6/30/06; 7/10/06-7/27/06	419,624	100.0	419,624.00	1	1	0	0	0
York Spit Channel	04/01/04-04/06/04; 5/23/04-5/28/04	93,665	100.0	93,665.00	0	0	0	0	0
Thimble Shoal Channel	4/5/04-4/20/04; 4/30/04-5/01/04; 5/29/04-6/16/04	426,588	100.0	426,588.00	0	0	0	0	0
York River Entrance Channel	9/9/03-9/11/03; 10/17/03-11/30/03	268,641	100.0	268,641.00	0	0	0	0	0
Sandbridge Beach	05/1/03-5/25/03	1,500,000	100.0	1,500,000.00	0	0	0	0	0

Thimble Shoal Channel (VA Beach)	8/24/03-12/28/03	1,300,223	77.8	1,011,573.49	9	7	1	0	1
Cape Henry Channel	4/12/02-8/19/02; 10/21/02-11/02/02	2,449,285	100.0	2,449,285.00	8	6	1	1	0
York Spit Channel	8/20/02-10/21/02; 11/03/02-11/05/02	978,846	100.0	978,846.00	9	8	1	0	0
Cape Henry Channel	09/17/01-01/14/02	1,641,140	62.2	1,020,789.08	3	2	1	0	0
VA Beach Hurricane Protection (Thimble Shoal Channel)	6/26/01-11/30/01	4,000,000	100.0	4,000,000.00	6	5	0	0	1
Cape Henry Channel	04/08/00-06/02/00	541,037	100.0	541,037.00	0	0	0	0	0
Thimble Shoal Channel	6/22/00-7/31/00; 8/13/00-9/19/00; 12/16/99-1/23/00	1,370,316	66.7	914,000.77	3	2	0	0	1
Cape Henry Channel	1/5/98-3/25/98	1,169,639	0.000	-	0	0	0	0	0

York River Entrance Channel	8/22/98-11/03/98	853,743	100.0	853,743.00	6	6	0	0	0	
York Spit Channel	3/26/98-5/31/98	371,200	92.4	342,988.80	0	0	0	0	0	
Cape Henry Channel	1/05/98-3/25/98	1,169,639	0.000	-	0	0	0	0	0	
Thimble Shoal Channel	05/07/96-06/03/96	282,431	100.0	282,431.00	1	1	0	0	0	
Cape Henry Channel	02/19/95-5/16/95	534,362	40.9	218,554.06						
Cape Henry Channel	4/11/94-5/12/94; 5/27/94-6/20/94	739,642	100.0	739,642.00	5	4	0	0	1	
York Spit Channel	6/21/94-6/28/94	141,434	100.0	141,434.00	4	4	0	0	0	
TOTAL:					18,442,566	64	54	5	1	4

8.1.1.2 Predicted Entrainment in Proposed Hopper Dredging

Based on the data in Table 7, we calculate that an average of one sea turtle is entrained for approximately every 300,000 cy removed (18,442,566 CY removed April – November divided by 64 total sea turtles). This calculation has been based on a number of assumptions including the following: that sea turtles are evenly distributed throughout all channel reaches for which takes have occurred, that all dredges will take an identical number of sea turtles, and that sea turtles are equally likely to be encountered throughout the April to November time frame. Based on these calculations, we expect that for any hopper dredging project in any of the channels or borrow areas considered in this Opinion during the time of year when sea turtles are likely to be present, one sea turtle is likely to be entrained for every 300,000 cubic yards of material removed by a hopper dredge. While this estimate is based on several assumptions, it is reasonable because it uses the best available information on entrainment of sea turtles from past dredging operations in the action area, includes multiple projects over several years, and all of the projects have had observer coverage.

Of the 64 entrained sea turtles, 60 have been identifiable to species; 54 were loggerheads, 5 Kemp's ridley and 1 green. Overall, of those identified to species, 90% were loggerheads, 8% Kemp's ridley and 2% green. The high percentage of loggerheads is likely due to several factors including their tendency to forage on the bottom where the dredge is operating and the fact that this species is the most numerous of the sea turtle species in Northeast and Mid-Atlantic waters. It is likely that

the documentation of only one green sea turtle entrainment in Virginia dredging operations is a reflection of the low numbers of green sea turtles that occur in waters north of North Carolina.

Based on the above information, it is reasonable to expect that one sea turtle is likely to be injured or killed for approximately every 300,000 cy of material removed from the channels and borrow areas considered in this Opinion when dredging is carried out between April and November, and that 90% will be loggerheads, 8% will be Kemp's ridley and 2% will be green. Because sea turtles do not occur in the action area from December – March, we do not expect any entrainment during these months. Approximately 1.5-2.0 million cy of sand will be removed from Sandbridge Shoals. At this time, it is anticipated that the majority of the work will occur outside of the April – November time period (currently scheduled for December 1 – May 15); however, because the actual schedule is dependent on weather conditions, dredge availability and other factors, we consider here the potential that all dredging could occur in the April – November period.

Based on the information outlined above and the volume of material estimated to be removed, we anticipate that a total of seven sea turtles will be entrained, with no more than one being a Kemp's ridley or green and the remainder being loggerheads.

8.1.3 Hopper Dredge Entrainment – Atlantic Sturgeon

Atlantic sturgeon are vulnerable to entrainment in hopper dredges. Entrainment is defined as the direct uptake of aquatic organisms by the suction field generated at the draghead. As explained above, since 1994, endangered species observers have been present for at least a portion of all hopper dredging done during the April – November time frame in the action area. Only two entrained Atlantic sturgeon have been documented during any hopper dredge activity in the action area, both in YSC in April 2011. Additionally, during sea turtle relocation trawling conducted in the fall of 2003 in conjunction with the 50-foot deepening of the inbound element of the Thimble Shoal Channel, 14 Atlantic sturgeon were captured by the trawler and released live in and around the channel; no incidental takes of Atlantic sturgeon by hopper dredge were observed during this period.

Entrainment of Atlantic sturgeon during hopper dredging operations in Federal navigation channels appears to be relatively rare. The USACE has documented a total of 35 incidents of sturgeon entrainment or capture of sturgeon species (all sturgeon species) on monitored projects for all types of dredge plant (mechanical, hydraulic pipeline, and hopper dredge). Twenty of the 35 documented observations were Atlantic sturgeon entrained by hopper dredge plants. A table presenting the observed sturgeon entrained or captured on monitored USACE projects between 1990 and March 2012 is presented as Appendix C to this Opinion. USACE-Norfolk District and Baltimore District hopper dredging projects have been monitored in the Chesapeake Bay since 1994 to present. During this period, observers have been present during the removal of more than 18 million cubic yards of dredged material have been removed from the channels considered in this consultation (see Table 7 above) with only two documented entrainments of Atlantic sturgeon.

Hydraulic dredges operate for prolonged periods underwater, with minimal disturbance, but generate continuous flow fields of suction forces while dredging. Entrainment is believed to occur primarily when the draghead is not in firm contact with the channel bottom, so the potential exist that sturgeon feeding or resting on or near the bottom may be vulnerable to entrainment.

Additionally, the size and flow rates produced by the suction power of the dredge, the condition of the channel being dredged, and the method of operation of the dredge and draghead all relate to the potential of the dredge to entrain Atlantic sturgeon (Reine and Clarke, 1998). These parameters also govern the ability of the dredge to entrain other species of fish, sea turtles, and shellfish.

Another factor influencing potential entrainment is based upon the swimming stamina and size of the individual fish at risk (Boysen and Hoover, 2009). Swimming stamina is positively correlated with total fish length. Entrainment of larger sturgeon is less likely due to the increased swimming performance and the relatively small size of the draghead opening. Juvenile entrainment is possible depending on the location of the dredging operations and the time of year in which the dredging occurs. Typically major concerns of juvenile entrainment relate to fish below 200 mm (Hoover et al., 2005; Boysen and Hoover, 2009). Juvenile sturgeon are not powerful swimmers and they are prone to bottom-holding behaviors, which make them vulnerable to entrainment when in close proximity to dragheads (Hoover et al., 2011).

On a hopper dredge, it is possible to monitor entrainment because the dredged material is retained on the vessels as opposed to the direct placement of dredged material both overboard or in confined disposal facilities by a hydraulic pipeline dredge. A hopper dredge contains screened inflow cages from which an observer can inspect recently dredged contents. Typically, the observer inspection is performed at the completion of each load while the vessel is transiting to the authorized placement area and does not impact production of the dredging operations.

In the fall of 2003, the Norfolk District captured fourteen Atlantic sturgeon during sea turtle relocation trawling activities supporting hopper dredging operations in Thimble Shoals Channel in the Chesapeake Bay. The Atlantic sturgeon were captured in the immediate vicinity of the dredging operation with no entrainment observed by NMFS approved observers onboard the hopper dredge before, during or after the relocation trawling where Atlantic sturgeon were captured.

Given the large size of adults (greater than 150cm) and the size of the openings on the dragheads, adult Atlantic sturgeon are unlikely to be vulnerable to entrainment. USACE reports that from 1990-2012, 37 confirmed interactions with sturgeon occurred during dredge operations (see Appendix C). Of these, 22 interactions were reported as Atlantic sturgeon (20 individuals), with 19 of these entrained in hopper dredges. Of the entrained Atlantic sturgeon for which size is available, all were subadults (larger than 50cm but less than 150cm). Information on these interactions is presented in Table 8. Most of these interactions occurred within rivers and harbors.

Table 8. USACE Atlantic Sturgeon Entrainment Records from Hopper Dredge Operations 1990-2011

Project Location	Corps Division/District*	Month/Year Interaction Observed	Cubic Yards Removed	Observed** Entrainment
-------------------------	---------------------------------	--	----------------------------	-------------------------------

Winyah Bay, Georgetown (SC)	SAD/SAC	Oct-90	517,032	1
Savannah Harbor (GA)	SAD/SAS	Jan-94	2,202,800	1
Savannah Harbor	SAD/SAS	Dec-94	2,239,800	1
Wilmington Harbor, Cape Fear River (NC)	SAD/SAW	Sep-98	196,400	1
Charleston Harbor (SC)	SAD/SAC	Mar-00	5,627,386	1
Brunswick Harbor (GA)	SAD/SAS	2-Feb	1,459,630	1
Charleston Harbor	SAD/SAC	4-Jan	1,449,234	1
Brunswick Harbor	SAD/SAS	5-Mar	966,000	1
Brunswick Harbor	SAD/SAS	6-Dec	1,198,571	1
Savannah Entrance Channel	SAD/SAS	7-Nov	973,463	1
Sandy Hook Channel (NJ)	NAD/NANY	8-Aug	23,500	1

Savannah Entrance Channel	SAD/SAS	9-Mar	261,780	1
Brunswick Entrance Channel	SAD/SAS	10-Feb	1,728,339	3
Wilmington Harbor	SAD/SAW	10-Dec	857,726	1
York Spit (VA)	NAD/NAN	11-Apr	1,630,713	2
Charleston Harbor	SAD/SAC	12-Mar	1,100,000	1
		Total	22,432,374	19

* SAD= South Atlantic Division; NAD= North Atlantic Division; SAC=Charleston District; SAS=Savannah District; SAW=Wilmington District; NANY=New York District; NAN=Norfolk District.

** Records based on sea turtle observer reports which record listed species entrained as well as all other organisms entrained during dredge operations.

In general, entrainment of large mobile animals, such as Atlantic sturgeon, is relatively rare. Several factors are thought to contribute to the likelihood of entrainment. In areas where animals are present in high density, the risk of an interaction is greater because more animals are exposed to the potential for entrainment. The risk of entrainment is likely to be higher in areas where the movements of animals are restricted (e.g., in narrow rivers or confined bays) where there is limited opportunity for animals to move away from the dredge than in unconfined areas such as wide rivers or open bays. The hopper dredge draghead operates on the bottom and is typically at least partially buried in the sediment. Sturgeon are benthic feeders and are often found at or near the bottom while foraging or while moving within rivers.

The only instances of Atlantic sturgeon entrainment in hopper dredges in the NMFS Northeast Region are two sturgeon entrained at York Spit, VA in 2011 (both were killed) and one live Atlantic sturgeon entrained in Sandy Hook, NJ in 2008. As described in the discussion of sea turtles above, many other hopper dredge projects have occurred in NMFS Northeast Region; nearly all of which overlap with times and areas where Atlantic sturgeon are known to be present. Because observers have been present on these dredges and we expect that any interactions with Atlantic sturgeon would have been reported to us, the interaction rate between hopper dredges and Atlantic sturgeon seems to be very low (1 Atlantic sturgeon for every 9 mcy removed for the action area, just considering the volume of material removed when observers were present). Even just considering the projects listed in Table 8, where entrainment was recorded, we calculate an entrainment rate of one Atlantic sturgeon for approximately every 1.2 million cy of material removed. If we consider

all projects in the action area where observers were present within the action area (see table 7) as well as projects outside the action area where interactions with Atlantic sturgeon were recorded (see table 8), we calculate an entrainment rate of 1 Atlantic sturgeon for every 2 mcy removed. The entrainment estimate generated above using all projects in the Chesapeake Bay where observers have been present plus all projects in rivers and bays where entrained Atlantic sturgeon have been observed is an overestimate because it does not consider other projects where no entrainment occurred. However, at this time, it is the best available estimate of entrainment rates for Atlantic sturgeon and hopper dredges. Just using the projects within Chesapeake Bay (table 7) is likely to be an underestimate because there has only been observer coverage between April and November and Atlantic sturgeon may be present year round.

Based on the above information, we expect one Atlantic sturgeon to be entrained for approximately every 2 mcy of material removed with a hopper dredge. Given the size of adult Atlantic sturgeon (greater than 150cm) and the size of observed entrained sturgeon (less than 150cm), we do not anticipate the entrainment of any adult Atlantic sturgeon. Given the location of the borrow areas to be dredged, only subadults and adults will be present; therefore, we anticipate that all entrained Atlantic sturgeon will be subadults less than 150cm in size.

There is evidence that some Atlantic sturgeon, particularly juveniles and small subadults, could be entrained in the dredge and survive. However, as the extent of internal injuries and the likelihood of survival is unknown, and the size of the fish likely to be entrained is impossible to predict, it is reasonable to conclude that any Atlantic sturgeon entrained in the hopper dredge are likely to be killed. Based on the dredge volume of up to 2 mcy, we anticipate the entrainment of no more than one subadult Atlantic sturgeon. This fish could originate from any of the five DPSs.

8.1.4 Interactions with the Sediment Plume- Hopper Dredge

Physical and biological impairments to the water column can occur from increases in turbidity which can alter light penetration. The proposed dredging will cause temporary increases in turbidity and suspension of sediments during dredging operations. As a result, the increase in turbidity can impact primary productivity and respiration of organisms within the project area. The re-suspension of sediments from dredging and dredged material placement can prevent or reduce gas-water exchanges in the gills of fish (Germano and Cary, 2005; Clarke and Wilber, 2000). The amount of impact that this can have on a species is dependent on the sensitivity of that species. This increase in turbidity can also impact prey species' predator avoidance response ability due to the decreased clarity in the water column.

Increased suspended sediment resulting from dredging can also reduce dissolved oxygen. Low dissolved oxygen conditions can be generated by the dredging operations from the resuspension of sediments and the biochemical oxygen demand of the surrounding water (Johnston, 1981). This can be particularly important during the summer months when water temperatures are warmer and less capable of holding dissolved oxygen. Dredging during the warmer months can exacerbate low dissolved oxygen conditions (Hatin et al., 2007a).

Dredging operations cause sediment to be suspended in the water column. This results in a sediment plume in the water, typically present from the dredge site and decreasing in concentration as sediment falls out of the water column as distance increases from the dredge site. The nature,

degree, and extent of sediment suspension around a dredging operation are controlled by many factors including : the particle size distribution, solids concentration, and composition of the dredged material; the dredge type and size, discharge/cutter configuration, discharge rate, and solids concentration of the slurry; operational procedures used; and the characteristics of the hydraulic regime in the vicinity of the operation, including water composition, temperature and hydrodynamic forces (i.e., waves, currents, etc.) causing vertical and horizontal mixing (USACE 1983).

Resuspension of fine-grained dredged material during hopper dredging operations is caused by the dragheads as they are pulled through the sediment, turbulence generated by the vessel and its prop wash, and overflow of turbid water during hopper filling operations. During the filling operation, dredged material slurry is often pumped into the hoppers after they have been filled with slurry in order to maximize the amount of solid material in the hopper. The lower density, turbid water at the surface of the filled hoppers overflows and is usually discharged through ports located near the waterline of the dredge. Use of this “overflow” technique results in a larger sediment plume than if no overflow is used. In 2001, a study was done in the Delaware River of overflow and nonoverflow hopper dredging. Monitoring of the sediment plumes was accomplished using a boat-mounted 1,200-kHz Broad-Band Acoustic Doppler Current Profiler (ADCP). The instrument collects velocity vectors in the water column together with backscatter levels to determine the position and relative intensity of the sediment plume. Along with the ADCP, a MicroLite recording instrument with an Optical Backscatterance (OBS) Sensor was towed by the vessel at a depth of 15 ft. The MicroLite recorded data at 0.5-sec intervals. Navigation data for monitoring were obtained by a Starlink differential Global Positioning System (GPS). The GPS monitors the boat position from the starting and ending points along each transect.

Transects were monitored in the test area to obtain the background levels of suspended materials prior to dredging activities. A period of 8 minutes following the dredge passing during non-overflow dredging showed the level of suspended material to be returning to background levels. No lateral dispersion of the plume out of the channel was observed during the non-overflow dredging operation. During overflow dredging, a wider transect was performed to determine the lateral extent of the plume. No significant change above background levels could be detected. At 1-hr elapsed time following the end of the overflow dredging operation, the levels of suspended material returned to background conditions. Again, no lateral dispersion of the plume out of the channel area was observed.

Overall, water quality impacts are anticipated to be minor and temporary in nature. Once dredging operations are complete the project area will soon return to ambient conditions due to the dilution or re-deposition of suspended sediments along with the strong littoral currents of the Chesapeake Bay and Atlantic Ocean.

No information is available on the effects of total suspended solids (TSS) on juvenile and adult sea turtles. Studies of the effects of turbid waters on fish suggest that concentrations of suspended solids can reach thousands of milligrams per liter before an acute toxic reaction is expected (Burton 1993). TSS is most likely to affect sea turtles if a plume causes a barrier to normal behaviors or if sediment settles on the bottom affecting sea turtle prey. As sea turtles are highly mobile they are likely to be able to avoid any sediment plume and any effect on sea turtle or whale movements is likely to be insignificant. While an increase in suspended sediments may cause sea turtles to alter their normal movements, any change in behavior is likely to be insignificant as it will only involve

movement to alter course out of the sediment plume, which is expected to be limited to the navigation channel and be present at any location for no more than 8 minutes. Based on this information, any increase in suspended sediment is not likely to affect the movement of sea turtles between foraging areas or while migrating or otherwise negatively affect listed species in the action area. Based on this information, it is likely that the effect of the suspension of sediment resulting from dredging operations will be insignificant.

The life stages of sturgeon most vulnerable to increased sediment are eggs and non-mobile larvae which are subject to burial and suffocation. As noted above, because of the distance of the project from the spawning grounds, no Atlantic sturgeon eggs and/or larvae will be present in the action area. Any Atlantic sturgeon in the action area during dredging would be capable of avoiding any sediment plume by swimming around it. Laboratory studies (Niklitschek 2001 and Secor and Niklitschek 2001) have demonstrated Atlantic sturgeon are able to actively avoid areas with unfavorable water quality conditions and that they will seek out more favorable conditions when available. While the increase in suspended sediments may cause sturgeon to alter their normal movements, any change in behavior is likely to be insignificant as it will only involve movement further up in the water column, or movement to an area just outside of the navigation channel. Based on this information, any increase in suspended sediment is not likely to affect the movement of Atlantic sturgeon between foraging areas and/or concentration areas during any phase of dredging or otherwise negatively affect sturgeon in the action area.

8.2 Hydraulic Cutterhead Dredge

Hydraulic pipeline dredges tend to be more efficient than the hopper style dredges because the pipeline conveys sand directly to the placement site. However, hydraulic pipeline dredges are not well-adapted to work in environments with high wave energy. Most pipeline dredges have a cutterhead on the suction end. A cutterhead is a mechanical device that has rotating blades or teeth to break up or loosen the bottom material so that it can be sucked through the dredge. Some cutterheads are rugged enough to break up rock for removal. Pipeline dredges are mounted (fastened) to barges and are not usually self-powered, but are towed to the dredging site and secured in place by special anchor piling, called spuds. To move the dredge, the operator's raises and lowers opposite spuds to crab crawl the dredge along at a much slower pace than hopper style dredges and are subsequently less maneuverable. A hydraulic pipeline dredge removes material by controlling the dragline on which the suction cutterhead is attached. This style of dredge works more efficiently when it can move slowly and remove deeper materials as it moves along using the spuds. Material is directly mixed with water as it is sucked into the pipeline and hydraulically pumped and sent directly to the spoil disposal site. This makes this style dredge more efficient than a hopper style dredge that is required to move to a pump-out site to dispose of material. The suction is created by hydraulic pumps either located on board or in route along the pipeline acting as a booster and creates the same low pressure around the drag heads as similar to a hopper dredge to force the material along the pipeline. As with the hopper style dredge, the more closely the drag head is maintained in contact with the sediment, the more efficient the dredging.

Sea turtles are not known to be vulnerable to entrainment in cutterhead dredges. This is thought to be due to the size of sea turtles and their swimming ability that allows them to escape the intake velocity near a cutterhead. There are no records of any sea turtles being entrained in cutterhead dredges in the Chesapeake Bay or anywhere else. Based on the available information, we do not

anticipate any entrainment of sea turtles if a cutterhead dredge is used for this project.

8.2.1 Available Information on the Risk of Entrainment of Sturgeon in Cutterhead Dredge

As noted above, a cutterhead dredge operates with the dredge head buried in the sediment; however, a flow field is produced by the suction of the operating dredge head. The amount of suction produced is dependent on linear flow rates inside the pipe and the pipe diameter (Clausner and Jones 2004). High flow rates and larger pipes create greater suction velocities and wider flow fields. The suction produced decreases exponentially with distance from the dredge head (Boysen and Hoover 2009). With a cutterhead dredge, material is pumped directly from the dredged area to a disposal site. As such, there is no opportunity to monitor for biological material on board the dredge; rather, observers work at the disposal site to inspect material.

It is generally assumed that sturgeon are mobile enough to avoid the suction of an oncoming cutterhead dredge and that any sturgeon in the vicinity of such an operation would be able to avoid the intake and escape. However, in mid-March 1996, two shortnose sturgeon were found in a dredge discharge pool on Money Island, near Newbold Island in the upper Delaware River. The dead sturgeon were found on the side of the spoil area into which the hydraulic pipeline dredge was pumping. An assessment of the condition of the fish indicated that the fish were likely alive and in good condition prior to entrainment and that they were both adult females. The area where dredging was occurring was a known overwintering area for shortnose sturgeon and large numbers of shortnose sturgeon were known to be concentrated in the general area. A total of 509,946 cy were dredged between Florence and the upper end of Newbold Island during this dredge cycle. Since that time, dredging occurring in the winter months in the Newbold – Kinkora range of the Delaware River required that inspectors conduct daily inspections of the dredge spoil area in an attempt to detect the presence of any sturgeon. In January 1998, three shortnose sturgeon carcasses were discovered in the Money Island Disposal Area. The sturgeon were found on three separate dates: January 6, January 12, and January 13. Dredging was being conducted in the Kinkora and Florence ranges at this time which also overlaps with the shortnose sturgeon overwintering area. A total of 512,923 cy of material was dredged between Florence and upper Newbold Island during that dredge cycle. While it is possible that not all shortnose sturgeon killed during dredging operations were observed at the dredge disposal pool, USACE has indicated that due to flow patterns in the pool, it is expected that all large material (i.e., sturgeon, logs etc.) will move towards the edges of the pool and be readily observable. Monitoring of dredge disposal areas used for deepening of the Delaware River with a cutterhead dredge has occurred. Dredging in Reach C occurred from March – August 2010 with 3,594,963 cy of material removed with a cutterhead dredge. Dredging in Reach B occurred in November and December 2011, with 1,100,000 cy of material removed with a cutterhead dredge. In both cases, the dredge disposal area was inspected daily for the presence of sturgeon. No sturgeon were detected.

In an attempt to understand the behavior of sturgeon while dredging is ongoing, the USACE worked with sturgeon researchers to track the movements of tagged Atlantic and shortnose sturgeon while cutterhead dredge operations were ongoing in Reach B (ERC 2011). The movements of acoustically tagged sturgeon were monitored using both passive and active methods. Passive monitoring was performed using 14 VEMCO VR2 and VR2W single-channel receivers, deployed through the study area. These receivers are part of a network that was established and cooperatively maintained by Environmental Research and Consulting, Inc. (ERC), Delaware State University

(DSU), and the Delaware Department of Natural Resources and Environmental Control (DNREC). Nineteen tagged Atlantic sturgeon and three tagged shortnose sturgeon (all juveniles) were in the study area during the time dredging was ongoing. Eleven of the 19 juvenile Atlantic sturgeon detected during this study remained upriver of the dredging area and showed high fidelity to the Marcus Hook anchorage. Three of the juvenile sturgeon detected during this study (Atlantic sturgeons 13417, 1769; shortnose sturgeon 58626) appeared to have moved through Reach B when the dredge was working. The patterns and rates of movement of these fish indicated nothing to suggest that their behavior was affected by dredge operation. The other sturgeon that were detected in the lower portion of the study area either moved through the area before or after the dredging period (Atlantic sturgeons 2053, 2054), moved through Reach B when the dredge was shut down (Atlantic sturgeons 1774, 58628, 58629), or moved through the channel on the east side of Cherry Island Flats (shortnose sturgeon 2090, Atlantic sturgeon 2091) opposite the main navigation channel. It is unknown whether some of these fish chose behaviors (routes or timing of movement) that kept them from the immediate vicinity of the operating dredge. In the report, Brundage speculates that this could be to avoid the noisy area near the dredge but also states that on the other hand, the movements of the sturgeon reported here relative to dredge operation could simply have been coincidence.

A similar study was carried out in the James River (Virginia) (Cameron 2012). Dredging occurred with a cutterhead dredge between January 30 and February 19, 2009 with 166,545 cy of material removed over 417.6 hours of active dredge time. Six subadult Atlantic sturgeon (77.5 – 100 cm length) were caught, tagged with passive and active acoustic tags, and released at the dredge site. The study concluded that: tagged fish showed no signs of impeded up- or downriver movement due to the physical presence of the dredge; fish were actively tracked freely moving past the dredge during full production mode; fish showed no signs of avoidance response (e.g., due to noise generated by the dredge) as indicated by the amount of time spent in close proximity to the dredge after release (3.5 – 21.5 hours); and, tagged fish showed no evidence of attraction to the dredge.

Several scientific studies have been undertaken to understand the ability of sturgeon to avoid cutterhead dredges. Hoover *et al.* (2011) demonstrated the swimming performance of juvenile lake sturgeon and pallid sturgeon (12 – 17.3 cm FL) in laboratory evaluations. The authors compared swimming behaviors and abilities in water velocities ranging from 10 to 90 cm/second (0.33-3.0 feet per second). Based on the known intake velocities of several sizes of cutterhead dredges. At distances more than 1.5 meters from the dredges, water velocities were negligible (10 cm/s). The authors conclude that in order for a sturgeon to be entrained in a dredge, the fish would need to be almost on top of the drag head and be unaffected by associated disturbance (e.g., turbidity and noise). The authors also conclude that juvenile sturgeon are only at risk of entrainment in a cutterhead dredge if they are in close proximity, less than 1 meter, to the cutterhead.

Boysen and Hoover (2009) assessed the probability of entrainment of juvenile white sturgeon by evaluating swimming performance of young of the year fish (8-10 cm TL). The authors determined that within 1.0 meter of an operating dredge head, all fish would escape when the pipe was 61 cm (2 feet) or smaller. Fish larger than 9.3 cm (about 4 inches) would be able to avoid the intake when the pipe was as large as 66 cm (2.2 feet). The authors concluded that regardless of fish size or pipe size, fish are only at risk of entrainment within a radius of 1.5 – 2 meters of the dredge head; beyond that distance velocities decrease to less than 1 foot per second.

Clarke (2011) reports that a cutterhead dredge with a suction pipe diameter of 36" (larger than the one to be used for this project) has an intake velocity of approximately 95 cm/s at a distance of 1 meter from the dredge head and that the velocity reduces to approximately 40cm/s at a distance of 1.5 meters, 25cm/s at a distance of 2.0 meters and less than 10cm/s at a distance of 3.0 meters. Clarke also reports on swim tunnel performance tests conducted on juvenile and subadult Atlantic, white and lake sturgeon. He concludes that there is a risk of sturgeon entrainment only within 1 meter of a cutterhead dredge head with a 36" pipe diameter and suction of 4.6m/second.

8.2.2 Predicted Entrainment of Atlantic sturgeon in a cutterhead dredge

The risk of an individual shortnose sturgeon being entrained in a cutterhead dredge is difficult to calculate. While a large area overall will be dredged, the dredge operates in an extremely small area at any given time (i.e., the river bottom in the immediate vicinity of the intake). As Atlantic sturgeon are expected to be well distributed throughout Sandbridge Shoal and an individual would need to be in the immediate area where the dredge is operating to be entrained (i.e., within 1 meter of the dredge head), the overall risk of entrainment is low. It is likely that the nearly all Atlantic sturgeon in the action area will never encounter the dredge as they would not occur within 1 meter of the dredge. Information from the tracking studies in the James and Delaware river supports these assessments of risk, as none of the tagged sturgeon were attracted to or entrained in the operating dredges.

The entrainment of five sturgeon in the upper Delaware River indicates that entrainment of sturgeon in cutterhead dredges is possible. However, there are several factors that may increase the risk of entrainment in that area of the river as compared to the areas where cutterhead dredging will occur for the deepening. All five entrainments occurred during the winter months in an area where shortnose sturgeon are known to concentrate in dense aggregations; sturgeon in these aggregations rest on the bottom and exhibit little movement and may be slow to respond to stimuli such as an oncoming dredge. Additionally, the area where dredging was occurring is fairly narrow and constricted which may limit the ability of sturgeon to avoid the oncoming dredge. These conditions are not present in Sandbridge Shoal.

Because the only entrainment of Atlantic or shortnose sturgeon in cutterhead dredges in the United States has been the five shortnose sturgeon found at the disposal site in the upper Delaware River it is difficult to predict the number of Atlantic sturgeon that are likely to be entrained during dredging at Sandbridge Shoal. Based on the available information presented here, entrainment in a cutterhead dredge is likely to be rare, and would only occur if a sturgeon was within 1 meter of the dredge head. Based on the predicted rarity of the entrainment event and the volume of material to be removed, we expect that no more than one Atlantic sturgeon will be entrained if a cutterhead dredge is used for dredging at Sandbridge Shoal. The entrained Atlantic sturgeon is expected to be a subadult and could originate from any of the five DPSs. Due to the suction, travel through up to several miles of pipe and any residency period in the disposal area, any entrained Atlantic sturgeon are expected to be killed.

8.2.3 Interactions with the Sediment Plume

The increased turbidity and suspended sediments related to the dredging and placement activities are anticipated to have short term, temporary impacts to water quality. Placement of sand at the

designated beach nourishment site will be via hydraulic pipeline. Sand will be deposited directly on the beach and graded to profile. Fine particles that may be present in the sand will be transported along with the carrier water back and dispersed in the swash zone.

Dredging operations cause sediment to be suspended in the water column. This results in a sediment plume in the river, typically present from the dredge site and decreasing in concentration as sediment falls out of the water column as distance increases from the dredge site. Dredging with a pipeline dredge minimizes the amount of material re-suspended in the water column as the material is essentially vacuumed up and transported to the disposal site in a pipe.

As reported by USACE, a near-field water quality modeling of dredging operations in the Delaware River was conducted in 2001. The purpose of the modeling was to evaluate the potential for sediment contaminants released during the dredging process to exceed applicable water quality criteria. The model predicted suspended sediment concentrations in the water column at downstream distances from a working cutterhead dredge in fine-grained dredged material. Suspended sediment concentrations were highest at the bottom of the water column, and returned to background concentrations within 100 meters downstream of the dredge.

In 2005, FERC presented NMFS with an analysis of results from the DREDGE model used to estimate the extent of any sediment plume associated with the proposed dredging at the Crown Landing LNG berth (FERC 2005). The model results indicated that the concentration of suspended sediments resulting from hydraulic dredging would be highest close to the bottom and would decrease rapidly downstream and higher in the water column. Based on a conservative (i.e., low) TSS background concentration of 5mg/L, the modeling results indicated that elevated TSS concentrations (i.e., above background levels) would be present at the bottom 2 meters of the water column for a distance of approximately 1,150 feet. Based on these analyses, elevated suspended sediment levels are expected to be present only within 1,150 feet of the location of the cutterhead. Turbidity levels associated with cutterhead dredge sediment plumes typically range from 11.5 to 282 mg/L with the highest levels detected adjacent to the cutterhead and concentrations decreasing with greater distance from the dredge (see U. Washington 2001).

Studies of the effects of turbid waters on fish suggest that concentrations of suspended solids can reach thousands of milligrams per liter before an acute toxic reaction is expected (Burton 1993). The studies reviewed by Burton demonstrated lethal effects to fish at concentrations of 580mg/L to 700,000mg/L depending on species. Sublethal effects have been observed at substantially lower turbidity levels. For example, prey consumption was significantly lower for striped bass larvae tested at concentrations of 200 and 500 mg/L compared to larvae exposed to 0 and 75 mg/L (Breitburg 1988 in Burton 1993). Studies with striped bass adults showed that pre-spawners did not avoid concentrations of 954 to 1,920 mg/L to reach spawning sites (Summerfelt and Moiser 1976 and Combs 1979 in Burton 1993).

The life stages of sturgeon most vulnerable to increased sediment are eggs and non-mobile larvae which are subject to burial and suffocation. As noted above, no sturgeon eggs and/or larvae will be present in the action area. Subadult and adult Atlantic sturgeon are frequently found in turbid water and would be capable of avoiding any sediment plume by swimming higher in the water column. All sturgeon in the action area would be sufficiently mobile to avoid any sediment plume.

Therefore, any Atlantic sturgeon in the action area during dredging would be capable of avoiding any sediment plume by swimming around it.

8.3 Dredged Material Disposal

We have considered whether the disposal of sand at Sandbridge Beach would impact sea turtles. Limited loggerhead sea turtle nesting (less than 10 nests per year) occurs on Virginia Beach; no nesting is known to occur on Sandbridge Beach. The disposal of material at Sandbridge is meant to stabilize and restoring eroding habitats and maintain existing beach. None of the activity is likely to reduce the suitability of these beaches for potential future nesting.

As indicated above, all material removed by cutterhead dredge will be disposed of at a beach location. When a cutterhead dredge is used, the material is piped directly from the intake to an onshore disposal area. The pipe will extend up to 3 miles, depending on the distance between the dredge site and the disposal site. The pipe will be approximately 30" in diameter and be laid on the ocean bottom. While the presence of the pipe will cause a small amount of benthic habitat to be unavailable to sturgeon and sea turtles, the extremely small area affected will cause any effects to be insignificant and discountable. While this could cause a small increase in suspended sediment in the immediate vicinity of sand placement, any effects are likely to be minor and temporary. Impacts associated with this action include a short term localized increase in turbidity during disposal operations. During the discharge of sediment at a disposal site, suspended sediment levels have been reported as high as 500mg/L within 250 feet of the disposal vessel and decreasing to background levels (i.e., 15-100mg/L depending on location) within 1,000-6,500 feet (USACE 1983). For this project, the USACE has reported that because the dredged material is clean sand, the material will settle out quickly and any sediment plume will be localized and temporary. Any sea turtles or sturgeon in the vicinity of the beach disposal sites during disposal may temporarily avoid the disposal area; however, as any effects to movements will be small and temporary, these effects will be insignificant. Similar effects of suspended sediment and turbidity will be experienced at the ocean disposal sites; as such, effects to sturgeon and sea turtles will be insignificant and discountable. Effects of disposal on prey resources are considered in section 7.5.

8.4 Effects on Benthic Resources and Foraging

8.4.1 Effects to Sea Turtles

Since dredging involves removing the bottom material down to a specified depth, the benthic environment will be impacted by dredging operations. No sea grass beds occur in the areas to be dredged with a hopper dredge, therefore green sea turtles will not use the areas as foraging areas. Thus, NMFS anticipates that the dredging activities are not likely to disrupt normal feeding behaviors for green sea turtles. Records from previous dredge events occurring in the action area indicate that some benthic resources, including whelks, horseshoe crabs, blue crabs and rock crabs are entrained during dredging. Other sources of information indicate that potential sea turtle forage items are present in the channel, including jellyfish, clams, mussels, sea urchins, whelks, horseshoe crabs, blue crabs and rock crabs.

Of the listed species found in the action area, loggerhead and Kemp's ridley sea turtles are the most likely to utilize the channel areas for feeding with the sea turtles foraging mainly on benthic species, namely crabs and mollusks (Morreale and Standora 1992, Bjorndal 1997). As noted above, suitable

sea turtle forage items occur in the channel. As preferred sea turtle and sturgeon foraging items occur at the channel areas and depths are suitable for use by sea turtles, some foraging by these species likely occurs at these sites.

Dredging can cause indirect effects on sea turtles by reducing prey species through the alteration of the existing biotic assemblages. Kemp's ridley and loggerhead sea turtles typically feed on crabs, other crustaceans and mollusks. Some of the prey species targeted by turtles, including crabs, are mobile; therefore, some individuals are likely to avoid the dredge; however, there is likely to be some entrainment of sea turtle prey items.

Previous studies in the upper Chesapeake Bay have demonstrated rapid recovery and resettlement by benthic biota and similar biomass and species diversity to pre-dredging conditions (Johnston, 1981; Diaz, 1994). Similar studies in the lower portions of the Chesapeake Bay produced rapid resettlement of dredging and placement areas by infauna (Sherk, 1972). McCauley et al. (1977) observed that while infauna populations declined significantly after dredging, infauna at dredging and placement areas recovered to pre-dredging conditions within 28 and 14 days, respectively. Therefore, the direct and indirect impacts to benthic communities are anticipated to be minimal. Rapid recovery and resettlement of benthic species is expected.

Based on this analysis, while there will be a small reduction in sea turtle prey due to dredging, these effects will be insignificant to foraging loggerhead and Kemp's ridley sea turtles. No effects to the prey base of green or leatherback sea turtles are anticipated.

8.4.2 Effects to Atlantic sturgeon

Atlantic sturgeon feed on a variety of benthic invertebrates. The proposed dredging is likely to entrain and kill at least some of these potential forage items. Given the limited mobility of most benthic invertebrates that sturgeon feed on, most are unlikely to be able to actively avoid the dredge. As noted above, recovery of the benthic community is expected to be rapid. Also as explained above for sea turtles, the area dredged in any particular year is a very small percentage of the available foraging habitat in the action area. Because effects to benthic prey will be limited to the area immediately surrounding the dredged area, the potential for disruption in foraging is low.

8.5 Dredge and Disposal Vessel Traffic

There have not been any reports of dredge vessels colliding with listed species but contact injuries resulting from dredge movements could occur at or near the water surface and could therefore involve any of the listed species present in the area. Because the dredge is unlikely to be moving at speeds greater than three knots during dredging operations, blunt trauma injuries resulting from contact with the hull are unlikely during dredging. It is more likely that contact injuries during actual dredging would involve the propeller of the vessel. Contact injuries with the dredge are more likely to occur when the dredge is moving from the dredging area to port, or between dredge locations. While the distance between these areas is relatively short, the dredge in transit would be moving at faster speeds than during dredging operations, particularly when empty while returning to the borrow area.

The dredge vessel may collide with sea turtles when they are at the surface. Sea turtles have been documented with injuries consistent with vessel interactions. It is reasonable to believe that the

dredge vessels considered in this Opinion could inflict such injuries on sea turtles, should they collide. As mentioned, sea turtles are found distributed throughout the action area in the warmer months, generally from May through mid-November.

Interactions between vessels and sea turtles occur and can take many forms, from the most severe (death or bisection of an animal or penetration to the viscera), to severed limbs or cracks to the carapace which can also lead to mortality directly or indirectly. Sea turtle stranding data for the U.S. Gulf of Mexico and Atlantic coasts, Puerto Rico, and the U.S. Virgin Islands show that between 1986 and 1993, about 9% of living and dead stranded sea turtles had propeller or other boat strike injuries (Lutcavage et al. 1997). According to 2001 STSSN stranding data, at least 33 sea turtles (loggerhead, green, Kemp's ridley and leatherbacks) that stranded on beaches within the northeast (Maine through North Carolina) were struck by a boat. This number underestimates the actual number of boat strikes that occur since not every boat struck turtle will strand, every stranded turtle will not be found, and many stranded turtles are too decomposed to determine whether the turtle was struck by a boat. It should be noted, however, that it is not known whether all boat strikes were the cause of death or whether they occurred post-mortem (NMFS SEFSC 2001).

Information is lacking on the type or speed of vessels involved in turtle vessel strikes. However, there does appear to be a correlation between the number of vessel struck turtles and the level of recreational boat traffic (NRC 1990). Although little is known about a sea turtle's reaction to vessel traffic, it is generally assumed that turtles are more likely to avoid injury from slower-moving vessels since the turtle has more time to maneuver and avoid the vessel. The speed of the dredge is not expected to exceed 3 knots while dredging or while transiting to the pump out site with a full load and it is expected to operate at a maximum speed of 10 knots while empty. In addition, the risk of ship strike will be influenced by the amount of time the animal remains near the surface of the water. For the proposed action, the greatest risk of vessel collision will occur during transit between shore and the areas to be dredged. The presence of an experienced endangered species observer who can advise the vessel operator to slow the vessel or maneuver safely when sea turtles are spotted will further reduce the potential risk for interaction with vessels. The addition of one to two slow moving vessels in the action area have an insignificant effect on the risk of interactions between sea turtles and vessels in the action area.

Information regarding the risk of vessel strikes to Atlantic sturgeon is discussed in the Status of the Species and Environmental Baseline sections above. As explained there, we have limited information on vessel strikes and many variables likely affect the potential for vessel strikes in a given area. Assuming that the risk of vessel strike increases with an increase in vessel traffic, we have considered whether an increase in vessel traffic in the action area during dredging and disposal (one to two slow moving vessels per day) would increase the risk of vessel strike for Atlantic sturgeon in this area. Given the large volume of traffic in the action area and the wide variability in traffic in any given day, the increase in traffic of one to two vessels per day is negligible and the increased risk to Atlantic sturgeon is insignificant.

8.6 Unexploded Ordnance and Munitions of Concern

The United States Army Environmental Command (USAEC) defines unexploded ordnance (UXO) or munitions of explosive concern (MEC) as military munitions that have been (1) primed, fused, armed or otherwise prepared for action; (2) fired, dropped, launched, projected, or

placed in such a manner to constitute a hazard to operations, installations, personnel, or material, and (3) remain unexploded either by malfunction, design, or any other case. UXO/MEC comes in many shapes and sizes, may be completely visible or partially or completely buried, and may be easy or virtually impossible to recognize as a military munition. UXO/MEC can be found in the ocean. UXO/MEC may look like a bullet or bomb, or be in many pieces, but even small pieces of UXO/MEC can be dangerous. If disturbed, (touched, picked up, played with, kicked, thrown, etc.) UXO/MEC may explode without warning, resulting in serious injury or even death. Sandbridge Shoal borrow area occurs in an area associated with past and current military activities and has produced UXO/MEC during dredging operations.

The presence of UXO in dredged material presents two unique challenges. First, it poses a potential explosive safety hazard to dredging or observer personnel and potential damage to equipment and vessel. Second, any subsequent beneficial use of dredged material must also address the possibility of the presence of UXO and/or its removal.

The presence of UXO was documented during the previous Sandbridge Hurricane Protection Projects constructed in 2002 and 2007. Over 100 UXO were recovered during dredging operations and were transported to and properly disposed of at an undisclosed naval installation. Recent dredging of the Cape Henry Channel, documented UXO/MEC in the observer cages on April 15, 2011 and May 8, 2011. On April 1, 2006, the Dredge Padre Island operated by the Great Lakes Dredge & Dock Company was conducting maintenance dredging activities in the Atlantic Ocean Channel (AOC) when it suffered a ruptured dredge clean out section and severed drag head as a result of an explosion presumed to be from an ordnance device that was pumped into the draghead and associated lines. Unexploded ordnance had been previously retrieved from the draghead on three different occasions in February 2006. During the last dredging cycle of the AOC in February 2011, it was documented that UXO/MEC was encountered four times, mostly 5-inch shells, two of which were determined to be live ordnance. A UXO/MEC device also is presumed to be the cause of an explosion on a hydraulic cutter-head dredge conducting maintenance dredging in Norfolk Harbor in April 2005 rupturing the primary pump casing on the dredge. The Coast Guard rendered assistance to the dredge plant to provide additional pump-out capacity for the incoming water and stabilize the plant. Fortunately, in most incidents UXO has not detonated and has been safely removed or jettisoned from the vessel.

As a safety precaution, in any area where UXO may be encountered (including some if not all portions of Sandbridge Shoal), the USACE will install special intake screening to be permanently placed over the drag head to effectively prevent any UXO from entering the hopper and/or being subsequently placed within the associated placement site. Additionally, USACE will install screening at the point where the material is discharged onto the beach. Special intake screening for UXO/MEC will be specified and installed to prevent entrainment of any material greater than 1-1/4 inches in diameter. Typical allowable openings specified by USACE-Norfolk District are 1-1/4 inches x 6 inches. While use of this screening poses challenges for monitoring interactions with listed species (see section 11 below), its use is not expected to change the entrainment rates calculated above. That is because, while it may prevent turtles or sturgeon from entering the intake pipes, it does not change the way the dredge operates or the suction power at the intake. So, while sea turtles or sturgeon may be less likely to be sucked through the dredge plant (as this could be

prevented by the small size of the intakes resulting from the screening), the risk of an interaction does not change.

8.7 Bed Leveling Devices

Bed-leveling is often associated with hopper dredging (and other types of dredging) operations. Bed-levelers redistribute sediments, rather than removing them. Plows, I-beams, or other seabed-leveling mechanical dredging devices are used to lower high spots left in channel bottoms and dredged material deposition areas by hopper dredges or other type dredges. Leveling devices typically weigh about 30 to 50 tons, are fixed with cables to a derrick mounted on a barge pushed or pulled by a tugboat at about one to two knots.

We have considered the potential for sea turtles to be crushed as the leveling device passes over a turtle which fails to move or is not pushed out of the way by the sediment wedge “wave” generated by and pushed ahead of the device. Sea turtles at Brunswick Harbor, Georgia, may have been crushed and killed in 2003 by bed-leveling which commenced after the hopper dredge finished its work in a particular area. Brunswick Harbor is a site where sea turtles captured by relocation trawlers sometimes show evidence of brumating (over-wintering) in the muddy channel bottom, which could explain why, if they were in fact crushed, they failed to react quickly enough to avoid the bed-leveler.

USACE has engaged in efforts to design bed leveler devices that are more likely to push sea turtles out of the way (much like a deflector on a hopper dredge); it is thought that this would reduce any potential for crushing. The available information on bed leveling and sea turtles indicates that crushing is extremely unlikely outside of areas where sea turtles are brumating. Additionally, the proposed modifications (i.e., integrated deflector configurations) to traditional bed-levelers are expected to further reduce the potential for impacts to sea turtles.

Subadult and adult Atlantic sturgeon are likely to be able to avoid being crushed by a bed-leveler. These fish are highly mobile. The low rate of entrainment of this species in any type of dredge suggests an ability to avoid interactions with dredge gear including bed levelers. No reports of injured or dead sturgeon have been reported in association with any bed leveling activities. As such, we do not anticipate any Atlantic sturgeon to be injured or killed if a bed leveler is used.

9.0 CUMULATIVE EFFECTS

Cumulative effects, as defined in 50 CFR § 402.02, are those effects of future State or private activities, not involving Federal activities, which are reasonably certain to occur within the action area. Future Federal actions are not considered in the definition of “cumulative effects.”

Actions carried out or regulated by the State of Virginia within the action area that may affect sea turtles and Atlantic sturgeon include the authorization of state fisheries and the regulation of dredged material discharges through CWA 401-Certification and point and non-point source pollution through the National Pollutant Discharge point and non-point source pollution through the National Pollutant Discharge Elimination System (NPDES). We are not aware of any local or private actions that are reasonably certain to occur in the action area that may affect listed species. It is important to note that the definition of “cumulative effects” in the section 7 regulations is not

the same as the NEPA definition of cumulative effects.⁹

State Water Fisheries - Future recreational and commercial fishing activities in state waters may take shortnose and Atlantic sturgeon. Information on interactions with sea turtles and Atlantic sturgeon for state fisheries operating in the action area is summarized in the Environmental Baseline section above, and it is not clear to what extent these future activities would affect listed species differently than the current state fishery activities described in the Status of the Species/Environmental Baseline section. However, this Opinion assumes effects in the future would be similar to those in the past and are, therefore, reflected in the anticipated trends described in the status of the species/environmental baseline section.

State PDES Permits – Virginia has been delegated authority to issue NPDES permits by the EPA. These permits authorize the discharge of pollutants in the action area. Permittees include municipalities for sewage treatment plants and other industrial users. The states will continue to authorize the discharge of pollutants through the SPDES permits. However, this Opinion assumes effects in the future would be similar to those in the past and are therefore reflected in the anticipated trends described in the status of the species/environmental baseline section.

10.0 INTEGRATION AND SYNTHESIS OF EFFECTS

In the effects analysis outlined above, we considered potential effects from planned dredging in Sandbridge Shoals in 2012-2013. These effects include: (1) dredging with cutterhead or hopper dredges; (2) bed leveling; and, (3) physical alteration of the action area including disruption of benthic communities. In addition to these categories of effects, NMFS considered the potential for collisions between listed species and project vessels. We anticipate the mortality of seven sea turtles (six loggerheads and no more than one Kemp's ridley or green sea turtle) and one Atlantic sturgeon from any of the five DPSs. Mortality of sea turtles will result from entrainment in hopper dredges operating between April and November. Mortality of Atlantic sturgeon will occur from entrainment in hopper and/or cutterhead dredges. As explained in the "Effects of the Action" section, effects of the dredging on habitat and benthic resources will be insignificant and discountable. We do not anticipate any take of sea turtles or Atlantic sturgeon due to any of the other effects including vessel traffic and dredge disposal.

In the discussion below, we consider whether the effects of the proposed action reasonably would be expected, directly or indirectly, to reduce appreciably the likelihood of both the survival and recovery of the listed species in the wild by reducing the reproduction, numbers, or distribution of the listed species that will be adversely affected by the action. The purpose of this analysis is to determine whether the proposed action, in the context established by the status of the species, environmental baseline, and cumulative effects, would jeopardize the continued existence of any listed species. In the NMFS/USFWS Section 7 Handbook, for the purposes of determining jeopardy, survival is defined as,

“the species’ persistence as listed or as a recovery unit, beyond the conditions leading to its endangerment, with sufficient resilience to allow for the potential recovery from

⁹ Cumulative effects are defined for NEPA as “the impact on the environment, which results from the incremental impact of the action when added to other past, present, and reasonably foreseeable future actions regardless of what agency (Federal or non-Federal) or person undertakes such other actions. Cumulative impacts can result from individually minor but collectively significant actions taking place over a period of time.”

endangerment. Said in another way, survival is the condition in which a species continues to exist into the future while retaining the potential for recovery. This condition is characterized by a species with a sufficient population, represented by all necessary age classes, genetic heterogeneity, and number of sexually mature individuals producing viable offspring, which exists in an environment providing all requirements for completion of the species' entire life cycle, including reproduction, sustenance, and shelter.”

Recovery is defined as, “Improvement in the status of listed species to the point at which listing is no longer appropriate under the criteria set out in Section 4(a)(1) of the Act.” We summarize below the status of the species and consider whether the proposed action will result in reductions in reproduction, numbers or distribution of these species and then considers whether any reductions in reproduction, numbers or distribution resulting from the proposed action would reduce appreciably the likelihood of both the survival and recovery of these species, as those terms are defined for purposes of the Endangered Species Act.

10.1 Atlantic sturgeon

As explained above, the proposed action is likely to result in the mortality of no more than 1 Atlantic sturgeon. This estimate applies if a hopper or cutterhead dredge is used. We expect that the Atlantic sturgeon killed will be a subadult. No mortality of any adults is anticipated. All other effects to Atlantic sturgeon, including effects to habitat and prey due to dredging and dredge disposal, will be insignificant and discountable.

10.1.1 Determination of DPS Composition

Using mixed stock analysis explained above, we have determined that Atlantic sturgeon in the action area likely originate from the five DPSs at the following frequencies: NYB 49%; South Atlantic 20%; Chesapeake Bay 14%; Gulf of Maine 11%; and Carolina 4%. Given these percentages, it is most likely that the entrained Atlantic sturgeon would originate from the New York Bight DPS but it is possible it could originate from any of the five DPSs.

10.1.2 Gulf of Maine DPS

Individuals originating from the GOM DPS are likely to occur in the action area. The GOM DPS has been listed as threatened. While Atlantic sturgeon occur in several rivers in the GOM DPS, recent spawning has only been documented in the Kennebec and Androscoggin rivers. No total population estimates are available. At this time, there is no published population estimate for the GOM DPS as a whole or for any life stage. We expect that 11% of the Atlantic sturgeon in the action area will originate from the GOM DPS. GOM origin Atlantic sturgeon are affected by numerous sources of human induced mortality and habitat disturbance throughout the riverine and marine portions of their range. While there are some indications that the status of the GOM DPS may be improving, there is currently not enough information to establish a trend for any life stage or for the DPS as a whole. We anticipate the mortality of no more than 1 subadult Atlantic sturgeon during the activity described in this Opinion. It is possible that the fish could originate from the GOM DPS. As noted above, we do not have an estimate of the number of subadult Atlantic sturgeon in the GOM DPS, the number of adults or the size of the GOM DPS as a whole. Here, we consider the effect of the loss of one subadult on the reproduction, numbers and distribution of the GOM DPS.

The reproductive potential of the GOM DPS will not be affected in any way other than through a

reduction in numbers of individuals. The loss of one subadult would have the effect of reducing the amount of potential reproduction as any dead GOM DPS Atlantic sturgeon would have no potential for future reproduction. However, because this action will result in the death of only one individual, this small reduction in potential future spawners is expected to result in an extremely small reduction in the number of eggs laid or larvae produced in future years and similarly, an extremely small effect on the strength of subsequent year classes. Even considering the potential future spawners that would be produced by the individual that would be killed as a result of the proposed action, any effect to future year classes is anticipated to be extremely small and would not change the status of this species. Reproductive potential of other captured or injured individuals is not expected to be affected in any way. Additionally, we have determined that any impacts to behavior will be minor and temporary and that there will not be any delay or disruption of any normal behavior including spawning; there will also be no reduction in individual fitness or any future reduction in numbers of individuals. The proposed action will also not affect the spawning grounds within the rivers where GOM DPS fish spawn. The action will also not create any barrier to pre-spawning sturgeon accessing the overwintering sites or the spawning grounds used by GOM DPS fish.

Because we do not have a population estimate for the GOM DPS, it is difficult to evaluate the effect of the mortality caused by this action on the species. However, because the proposed action will result in the loss of only one individual, it is unlikely that this death will have a detectable effect on the numbers and population trend of the GOM DPS.

The proposed action is not likely to reduce distribution because the action will not impede Atlantic sturgeon from accessing any seasonal concentration areas, including foraging areas within the action area that may be used by GOM DPS subadults or adults. Further, the action is not expected to reduce the river by river distribution of Atlantic sturgeon. Any effects to distribution will be minor and temporary and limited to the temporary avoidance of the area where suspended sediment levels are high.

Based on the information provided above, the death of no more than one GOM DPS Atlantic sturgeon, will not appreciably reduce the likelihood of survival of the GOM DPS (*i.e.*, it will not decrease the likelihood that the species will continue to persist into the future with sufficient resilience to allow for the potential recovery from endangerment). The action will not affect GOM DPS Atlantic sturgeon in a way that prevents the species from having a sufficient population, represented by all necessary age classes, genetic heterogeneity, and number of sexually mature individuals producing viable offspring, and it will not result in effects to the environment which would prevent Atlantic sturgeon from completing their entire life cycle, including reproduction, sustenance, and shelter. This is the case because: (1) the death of one subadult GOM DPS Atlantic sturgeon will not change the status or trends of the species as a whole; (2) the loss of one subadult GOM DPS Atlantic sturgeon is not likely to have an effect on the levels of genetic heterogeneity in the population; (3) the loss of one subadult GOM DPS Atlantic sturgeon is likely to have such a small effect on reproductive output that the loss of this individual will not change the status or trends of the species; (4) the action will have only a minor and temporary effect on the distribution of GOM DPS Atlantic sturgeon in the action area and no effect on the distribution of the species throughout its range; and, (5) the action will have no effect on the ability of GOM DPS Atlantic sturgeon to shelter and only an insignificant effect on any foraging GOM DPS Atlantic sturgeon.

In certain instances, an action that does not appreciably reduce the likelihood of a species' survival might affect its likelihood of recovery or the rate at which recovery is expected to occur. As explained above, we have determined that the proposed action will not appreciably reduce the likelihood that the GOM DPS will survive in the wild. Here, we consider the potential for the action to reduce the likelihood of recovery. As noted above, recovery is defined as the improvement in status such that listing is no longer appropriate. Thus, we have considered whether the proposed action will affect the likelihood that the GOM DPS can rebuild to a point where listing is no longer appropriate. No Recovery Plan for the GOM DPS has been published. The Recovery Plan will outline the steps necessary for recovery and the demographic criteria which once attained would allow the species to be delisted. We know that in general, to recover, a species must have a sustained positive trend over time and an increase in population. To allow those things to happen, a species must have enough habitat in suitable condition that allows all normal life functions to occur (i.e., spawning, foraging, resting) and have access to enough food. Here, we consider whether this proposed action will affect the population size and/or trend in a way that would affect the likelihood of recovery.

The proposed action is not expected to modify, curtail or destroy the range of the species since it will result in an extremely small reduction in the number of GOM DPS Atlantic sturgeon and since it will not affect the overall distribution of GOM DPS Atlantic sturgeon. Any effects to habitat will be insignificant and discountable and will not affect the ability of Atlantic sturgeon to carry out any necessary behaviors or functions. Any impacts to available forage will also be insignificant. The proposed action will result in an extremely small amount of mortality (one individual) and a subsequent small reduction in future reproductive output. For these reasons, it is not expected to affect the persistence of the GOM DPS of Atlantic sturgeon. This action will not change the status or trend of the GOM DPS of Atlantic sturgeon. The very small reduction in numbers and future reproduction resulting from the proposed action will not reduce the likelihood of improvement in the status of the GOM DPS of Atlantic sturgeon. The effects of the proposed action will not delay the recovery timeline or otherwise decrease the likelihood of recovery. The effects of the proposed action will also not reduce the likelihood that the status of the species can improve to the point where it is recovered and could be delisted. Therefore, the proposed action will not appreciably reduce the likelihood that the GOM DPS of Atlantic sturgeon can be brought to the point at which they are no longer listed as threatened. Based on the analysis presented herein, the proposed action, is not likely to appreciably reduce the survival and recovery of this species.

Despite the threats faced by individual GOM DPS Atlantic sturgeon inside and outside of the action area, the proposed action will not increase the vulnerability of individual sturgeon to these additional threats and exposure to ongoing threats will not increase susceptibility to effects related to the proposed action. We have considered the effects of the proposed action in light of cumulative effects explained above, including climate change, and have concluded that even in light of the ongoing impacts of these activities and conditions; the conclusions reached above do not change. Based on the analysis presented herein, the proposed action, resulting in the mortality of one subadult GOM DPS Atlantic sturgeon, is not likely to appreciably reduce the survival and recovery of this species.

10.1.3 New York Bight DPS

We expect that 49% of the Atlantic sturgeon in the action area will originate from the NYB DPS. The NYB DPS has been listed as endangered. While Atlantic sturgeon occur in several rivers in the NYB DPS, recent spawning has only been documented in the Delaware and Hudson rivers. Kahnle *et al.* (2007) estimated that there is a mean annual total mature adult population of 863 Hudson River Atlantic sturgeon. Fisheries bycatch data suggests that the ratio of subadults to adults is at least 3:1. Therefore, we estimate that there are at least 2,589 subadults. At this time, we do not have an estimate of the number of Delaware River origin Atlantic sturgeon; however, because spawning is thought to persist in the Delaware, this river contributes additional sturgeon of all life stages to the DPS. NYB DPS origin Atlantic sturgeon are affected by numerous sources of human induced mortality and habitat disturbance throughout the riverine and marine portions of their range. There is currently not enough information to establish a trend for any life stage, for the Hudson or Delaware River spawning populations or for the DPS as a whole. Some Delaware River fish have a unique genetic haplotype (the A5 haplotype); however, whether there is any evolutionary significance or fitness benefit provided by this genetic makeup is unknown. Genetic evidence indicates that while spawning continued to occur in the Delaware River and in some cases Delaware River origin fish can be distinguished genetically from Hudson River origin fish, there is free interchange between the two rivers. This relationship is recognized by the listing of the New York Bight DPS as a whole and not separate listings of a theoretical Hudson River DPS and Delaware River DPS. Thus, while we can consider the loss of Delaware River fish on the Delaware River population and the loss of Hudson River fish on the Hudson River population, it is more appropriate, because of the interchange of individuals between these two populations, to consider the effects of these mortalities on the New York Bight DPS as a whole.

We have estimated that the proposed action will result in the mortality of no more than 1 subadult Atlantic sturgeon; this fish is likely to originate from the NYB DPS. Any New York Bight DPS subadults could originate from the Delaware or Hudson river. The available information suggests that the vast majority of NYB DPS subadults originate from the Hudson River, therefore, given that only one NYB DPS fish is likely to be killed it is reasonable to assume that it will be Hudson River origin.

The mortality of 1 subadult Atlantic sturgeon from the NYB DPS represents a very small percentage of subadult population (*i.e.*, approximately 0.04% of the population, just considering the minimum estimated number of Hudson River origin subadults; the percentage would be much less if the number of adults, YOY and juveniles was considered as well as any Delaware River origin subadults). While the death of one subadult Atlantic sturgeon will reduce the number of NYB DPS Atlantic sturgeon compared to the number that would have been present absent the proposed action, it is not likely that this reduction in numbers will change the status of this species as this loss represents a very small percentage of the subadult population and an even smaller percentage of the overall population of the DPS (juveniles, subadults and adults combined). Even when converting this fish to adult equivalents¹⁰ (using a conversion rate of 0.48 considering the adult equivalent), and assuming no growth in the adult population, the mortality of 1 subadult represents an extremely small percentage of the adult population (approximately 0.06%).

Because there will be no loss of adults, the reproductive potential of the NYB DPS will not be

¹⁰ The “adult equivalent” rate converts a number of subadults to adult equivalents (the number of subadults that would, through natural mortality, live to be adults; for Atlantic sturgeon, this is calculated as 0.48).

affected in any way other than through a reduction in numbers of individual future spawners. The loss of 1 subadult would have the effect of reducing the amount of potential reproduction as any dead NYB DPS Atlantic sturgeon would have no potential for future reproduction. This small reduction in potential future spawners is expected to result in an extremely small reduction in the number of eggs laid or larvae produced in future years and similarly, an extremely small effect on the strength of subsequent year classes. Even considering the potential future spawners that would be produced by the individual that would be killed as a result of the proposed action, any effect to future year classes is anticipated to be extremely small and would not change the status of this species. The proposed action will also not affect the spawning grounds within the Hudson River or Delaware River where NYB DPS fish spawn. There will be no effects to spawning adults and therefore no reduction in individual fitness or any future reduction in spawning by these individuals.

The proposed action is not likely to reduce distribution because the action will not impede NYB DPS Atlantic sturgeon from accessing any seasonal concentration areas, including foraging, spawning or overwintering grounds in the Delaware or Hudson River or elsewhere. Any effects to distribution will be minor and temporary and limited to the temporary avoidance of the area immediately surrounding an active dredge.

Based on the information provided above, the death of one NYB DPS Atlantic sturgeon, will not appreciably reduce the likelihood of survival of the New York Bight DPS (*i.e.*, it will not decrease the likelihood that the species will continue to persist into the future with sufficient resilience to allow for the potential recovery from endangerment). The action will not affect NYB DPS Atlantic sturgeon in a way that prevents the species from having a sufficient population, represented by all necessary age classes, genetic heterogeneity, and number of sexually mature individuals producing viable offspring, and it will not result in effects to the environment which would prevent Atlantic sturgeon from completing their entire life cycle, including reproduction, sustenance, and shelter. This is the case because: (1) the death of this subadult NYB DPS Atlantic sturgeon represents an extremely small percentage of the species; (2) the death of one subadult NYB DPS Atlantic sturgeon will not change the status or trends of the species as a whole; (3) the loss of one subadult NYB DPS Atlantic sturgeon is not likely to have an effect on the levels of genetic heterogeneity in the population; (4) the loss of one subadult NYB DPS Atlantic sturgeon is likely to have such a small effect on reproductive output that the loss of these individuals will not change the status or trends of the species; (5) the action will have only a minor and temporary effect on the distribution of NYB DPS Atlantic sturgeon in the action area and no effect on the distribution of the species throughout its range; and, (6) the action will have no effect on the ability of NYB DPS Atlantic sturgeon to shelter and only an insignificant effect on individual foraging NYB DPS Atlantic sturgeon.

In certain instances, an action that does not appreciably reduce the likelihood of a species' survival might affect its likelihood of recovery or the rate at which recovery is expected to occur. As explained above, we have determined that the proposed action will not appreciably reduce the likelihood that the NYB DPS will survive in the wild. Here, we consider the potential for the action to reduce the likelihood of recovery. As noted above, recovery is defined as the improvement in status such that listing is no longer appropriate. Thus, we have considered whether the proposed action will affect the likelihood that the NYB DPS can rebuild to a point where listing is no longer appropriate. No Recovery Plan for the NYB DPS has been published. The Recovery Plan will

outline the steps necessary for recovery and the demographic criteria which once attained would allow the species to be delisted. We know that in general, to recover, a species must have a sustained positive trend over time and an increase in population. To allow those things to happen, a species must have enough habitat in suitable condition that allows all normal life functions to occur (i.e., spawning, foraging, resting) and have access to enough food. Here, we consider whether this proposed action will affect the population size and/or trend in a way that would affect the likelihood of recovery.

The proposed action is not expected to modify, curtail or destroy the range of the species since it will result in an extremely small reduction in the number of NYB DPS Atlantic sturgeon and since it will not affect the overall distribution of NYB DPS Atlantic sturgeon. Any effects to habitat will be insignificant and discountable and will not affect the ability of Atlantic sturgeon to carry out any necessary behaviors or functions. Any impacts to available forage will also be insignificant. The proposed action will result in an extremely small amount of mortality (one individual) and a subsequent small reduction in future reproductive output. For these reasons, it is not expected to affect the persistence of the NYB DPS of Atlantic sturgeon. This action will not change the status or trend of the NYB DPS of Atlantic sturgeon. The very small reduction in numbers and future reproduction resulting from the proposed action will not reduce the likelihood of improvement in the status of the NYB DPS of Atlantic sturgeon. The effects of the proposed action will not delay the recovery timeline or otherwise decrease the likelihood of recovery. The effects of the proposed action will also not reduce the likelihood that the status of the species can improve to the point where it is recovered and could be delisted. Therefore, the proposed action will not appreciably reduce the likelihood that the NYB DPS of Atlantic sturgeon can be brought to the point at which they are no longer listed as threatened. Based on the analysis presented herein, the proposed action, is not likely to appreciably reduce the survival and recovery of this species.

Despite the threats faced by individual NYB DPS Atlantic sturgeon inside and outside of the action area, the proposed action will not increase the vulnerability of individual sturgeon to these additional threats and exposure to ongoing threats will not increase susceptibility to effects related to the proposed action. Based on the analysis presented herein, the proposed action, resulting in the mortality of up to one subadult NYB DPS Atlantic sturgeon, is not likely to appreciably reduce the survival and recovery of this species.

10.1.4 Chesapeake Bay DPS

Individuals originating from the CB DPS are likely to occur in the action area. The CB DPS has been listed as endangered. While Atlantic sturgeon occur in several rivers in the CB DPS, recent spawning has only been documented in the James River. No estimates of the number of spawning adults, the DPS as a whole, or any life stage have been reported. We expect that 14% of the Atlantic sturgeon in the action area will originate from the CB DPS. Chesapeake Bay DPS origin Atlantic sturgeon are affected by numerous sources of human induced mortality and habitat disturbance throughout the riverine and marine portions of their range. There is currently not enough information to establish a trend for any life stage, for the James River spawning population or for the DPS as a whole. Here, we consider the effect of the loss of one subadult on the reproduction, numbers and distribution of the CB DPS.

The reproductive potential of the CB DPS will not be affected in any way other than through a

reduction in numbers of individuals. The loss of this subadult would have the effect of reducing the amount of potential reproduction as any dead CB DPS Atlantic sturgeon would have no potential for future reproduction. This small reduction in potential future spawners is expected to result in an extremely small reduction in the number of eggs laid or larvae produced in future years and similarly, an extremely small effect on the strength of subsequent year classes. Even considering the potential future spawners that would be produced by the individual that would be killed as a result of the proposed action, any effect to future year classes is anticipated to be extremely small and would not change the status of this species. Reproductive potential of other captured or injured individuals is not expected to be affected in any way. Additionally, we have determined that any impacts to behavior will be minor and temporary and that there will not be any delay or disruption of any normal behavior including spawning; there will also be no reduction in individual fitness or any future reduction in numbers of individuals. The proposed action will also not affect the spawning grounds within the rivers where CB DPS fish spawn. The action will also not create any barrier to pre-spawning sturgeon accessing the overwintering sites or the spawning grounds used by CB DPS fish.

Because we do not have a population estimate for the CB DPS, it is difficult to evaluate the effect of the mortality caused by this action on the species. However, because the proposed action will result in the loss of only one individual, it is unlikely that this death will have a detectable effect on the numbers and population trend of the CB DPS.

The proposed action is not likely to reduce distribution because the action will not impede Atlantic sturgeon from accessing any seasonal concentration areas, including foraging areas within the action area that may be used by CB DPS subadults or adults. Further, the action is not expected to reduce the river by river distribution of Atlantic sturgeon. Any effects to distribution will be minor and temporary and limited to the temporary avoidance of the immediate area where dredging is occurring.

Based on the information provided above, the death of no more than 1 CB DPS Atlantic sturgeon will not appreciably reduce the likelihood of survival of the CB DPS (*i.e.*, it will not decrease the likelihood that the species will continue to persist into the future with sufficient resilience to allow for the potential recovery from endangerment). The action will not affect CB DPS Atlantic sturgeon in a way that prevents the species from having a sufficient population, represented by all necessary age classes, genetic heterogeneity, and number of sexually mature individuals producing viable offspring, and it will not result in effects to the environment which would prevent Atlantic sturgeon from completing their entire life cycle, including reproduction, sustenance, and shelter. This is the case because: (1) the death of 1 subadult CB DPS Atlantic sturgeon over a 50-year period represents an extremely small percentage of the species as a whole; (2) the death of 1 subadult CB DPS Atlantic sturgeon will not change the status or trends of the species as a whole; (3) the loss of 1 subadult CB DPS Atlantic sturgeon is not likely to have an effect on the levels of genetic heterogeneity in the population; (4) the loss of 1 subadult CB DPS Atlantic sturgeon is likely to have such a small effect on reproductive output that the loss of this individual will not change the status or trends of the species; (5) the action will have only a minor and temporary effect on the distribution of CB DPS Atlantic sturgeon in the action area and no effect on the distribution of the species throughout its range; and, (6) the action will have no effect on the ability of CB DPS Atlantic sturgeon to shelter and only an insignificant effect on individual foraging CB DPS Atlantic

sturgeon.

In certain instances, an action that does not appreciably reduce the likelihood of a species' survival might affect its likelihood of recovery or the rate at which recovery is expected to occur. As explained above, we have determined that the proposed action will not appreciably reduce the likelihood that the CB DPS will survive in the wild. Here, we consider the potential for the action to reduce the likelihood of recovery. As noted above, recovery is defined as the improvement in status such that listing is no longer appropriate. Thus, we have considered whether the proposed action will affect the likelihood that the CB DPS can rebuild to a point where listing is no longer appropriate. No Recovery Plan for the CB DPS has been published. The Recovery Plan will outline the steps necessary for recovery and the demographic criteria which once attained would allow the species to be delisted. We know that in general, to recover, a species must have a sustained positive trend over time and an increase in population. To allow those things to happen, a species must have enough habitat in suitable condition that allows all normal life functions to occur (i.e., spawning, foraging, resting) and have access to enough food. Here, we consider whether this proposed action will affect the population size and/or trend in a way that would affect the likelihood of recovery.

The proposed action is not expected to modify, curtail or destroy the range of the species since it will result in an extremely small reduction in the number of CB DPS Atlantic sturgeon and since it will not affect the overall distribution of CB DPS Atlantic sturgeon. Any effects to habitat will be insignificant and discountable and will not affect the ability of Atlantic sturgeon to carry out any necessary behaviors or functions. Any impacts to available forage will also be insignificant. The proposed action will result in an extremely small amount of mortality (one individual) and a subsequent small reduction in future reproductive output. For these reasons, it is not expected to affect the persistence of the CB DPS of Atlantic sturgeon. This action will not change the status or trend of the CB DPS of Atlantic sturgeon. The very small reduction in numbers and future reproduction resulting from the proposed action will not reduce the likelihood of improvement in the status of the CB DPS of Atlantic sturgeon. The effects of the proposed action will not delay the recovery timeline or otherwise decrease the likelihood of recovery. The effects of the proposed action will also not reduce the likelihood that the status of the species can improve to the point where it is recovered and could be delisted. Therefore, the proposed action will not appreciably reduce the likelihood that the CB DPS of Atlantic sturgeon can be brought to the point at which they are no longer listed as threatened. Based on the analysis presented herein, the proposed action, is not likely to appreciably reduce the survival and recovery of this species.

Despite the threats faced by individual CB DPS Atlantic sturgeon inside and outside of the action area, the proposed action will not increase the vulnerability of individual sturgeon to these additional threats and exposure to ongoing threats will not increase susceptibility to effects related to the proposed action. We have considered the effects of the proposed action in light of cumulative effects explained above, including climate change, and have concluded that even in light of the ongoing impacts of these activities and conditions; the conclusions reached above do not change. Based on the analysis presented herein, the proposed action, resulting in the mortality of one subadult CB DPS Atlantic sturgeon, is not likely to appreciably reduce the survival and recovery of this species.

10.1.4 Carolina DPS

We expect that 4% of the Atlantic sturgeon in the action area will originate from the CA DPS. The CA DPS is listed as endangered. The CA DPS consists of Atlantic sturgeon originating from at least five rivers where spawning is still thought to occur. There are no estimates of the size of the CA DPS. The ASSRT estimated that there were fewer than 300 spawning adults in each of the five spawning rivers. Carolina DPS origin Atlantic sturgeon are affected by numerous sources of human induced mortality and habitat disturbance throughout the riverine and marine portions of their range. There is currently not enough information to establish a trend for any life stage, for any of the spawning populations or for the DPS as a whole. Here, we consider the effect of the loss of one subadult on the reproduction, numbers and distribution of the CA DPS.

The reproductive potential of the CA DPS will not be affected in any way other than through a reduction in numbers of individuals. The loss of one subadult would have the effect of reducing the amount of potential reproduction as any dead CA DPS Atlantic sturgeon would have no potential for future reproduction. This small reduction in potential future spawners is expected to result in an extremely small reduction in the number of eggs laid or larvae produced in future years and similarly, an extremely small effect on the strength of subsequent year classes. Even considering the potential future spawners that would be produced by the individual that would be killed as a result of the proposed action, any effect to future year classes is anticipated to be extremely small and would not change the status of this species. Additionally, we have determined that any impacts to behavior will be minor and temporary and that there will not be any delay or disruption of any normal behavior; there will also be no reduction in individual fitness or any future reduction in numbers of individuals. The proposed action will also not affect the spawning grounds within the rivers where CA DPS fish spawn. The action will also not create any barrier to pre-spawning sturgeon accessing the overwintering sites or the spawning grounds used by CA DPS fish.

Because we do not have a population estimate for the CA DPS, it is difficult to evaluate the effect of the mortality caused by this action on the species. However, because the proposed action will result in the loss of only one individual, it is unlikely that this death will have a detectable effect on the numbers and population trend of the CA DPS.

The proposed action is not likely to reduce distribution because the action will not impede Atlantic sturgeon from accessing any seasonal concentration areas, including foraging areas within the action area that may be used by CA DPS subadults or adults. Further, the action is not expected to reduce the river by river distribution of Atlantic sturgeon. Any effects to distribution will be minor and temporary and limited to the temporary avoidance of the immediate area where dredging is occurring.

Based on the analysis provided above, the death of no more than one CA DPS Atlantic sturgeon will not appreciably reduce the likelihood of survival of the CA DPS (*i.e.*, it will not decrease the likelihood that the species will continue to persist into the future with sufficient resilience to allow for the potential recovery from endangerment). The action will not affect CA DPS Atlantic sturgeon in a way that prevents the species from having a sufficient population, represented by all necessary age classes, genetic heterogeneity, and number of sexually mature individuals producing viable offspring, and it will not result in effects to the environment which would prevent Atlantic sturgeon from completing their entire life cycle, including reproduction, sustenance, and shelter.

This is the case because: (1) the death of one subadult CA DPS Atlantic sturgeon represents an extremely small percentage of the species as a whole; (2) the death of one subadult CA DPS Atlantic sturgeon will not change the status or trends of the species as a whole; (3) the loss of one subadult CA DPS Atlantic sturgeon is not likely to have an effect on the levels of genetic heterogeneity in the population; (4) the loss of one subadult CA DPS Atlantic sturgeon is likely to have such a small effect on reproductive output that the loss of this individual will not change the status or trends of the species; (5) the action will have only a minor and temporary effect on the distribution of CA DPS Atlantic sturgeon in the action area and no effect on the distribution of the species throughout its range; and, (6) the action will have no effect on the ability of CA DPS Atlantic sturgeon to shelter and only an insignificant effect on individual foraging CA DPS Atlantic sturgeon.

In certain instances, an action that does not appreciably reduce the likelihood of a species' survival might affect its likelihood of recovery or the rate at which recovery is expected to occur. As explained above, we have determined that the proposed action will not appreciably reduce the likelihood that the CA DPS will survive in the wild. Here, we consider the potential for the action to reduce the likelihood of recovery. As noted above, recovery is defined as the improvement in status such that listing is no longer appropriate. Thus, we have considered whether the proposed action will affect the likelihood that the CA DPS can rebuild to a point where listing is no longer appropriate. No Recovery Plan for the CA DPS has been published. The Recovery Plan will outline the steps necessary for recovery and the demographic criteria which once attained would allow the species to be delisted. We know that in general, to recover, a species must have a sustained positive trend over time and an increase in population. To allow those things to happen, a species must have enough habitat in suitable condition that allows all normal life functions to occur (i.e., spawning, foraging, resting) and have access to enough food. Here, we consider whether this proposed action will affect the population size and/or trend in a way that would affect the likelihood of recovery.

The proposed action is not expected to modify, curtail or destroy the range of the species since it will result in an extremely small reduction in the number of CA DPS Atlantic sturgeon and since it will not affect the overall distribution of CA DPS Atlantic sturgeon. Any effects to habitat will be insignificant and discountable and will not affect the ability of Atlantic sturgeon to carry out any necessary behaviors or functions. Any impacts to available forage will also be insignificant. The proposed action will result in an extremely small amount of mortality (one individual) and a subsequent small reduction in future reproductive output. For these reasons, it is not expected to affect the persistence of the CA DPS of Atlantic sturgeon. This action will not change the status or trend of the CA DPS of Atlantic sturgeon. The very small reduction in numbers and future reproduction resulting from the proposed action will not reduce the likelihood of improvement in the status of the CA DPS of Atlantic sturgeon. The effects of the proposed action will not delay the recovery timeline or otherwise decrease the likelihood of recovery. The effects of the proposed action will also not reduce the likelihood that the status of the species can improve to the point where it is recovered and could be delisted. Therefore, the proposed action will not appreciably reduce the likelihood that the CA DPS of Atlantic sturgeon can be brought to the point at which they are no longer listed as threatened. Based on the analysis presented herein, the proposed action, is not likely to appreciably reduce the survival and recovery of this species.

Despite the threats faced by individual CA DPS Atlantic sturgeon inside and outside of the action area, the proposed action will not increase the vulnerability of individual sturgeon to these additional threats and exposure to ongoing threats will not increase susceptibility to effects related to the proposed action. We have considered the effects of the proposed action in light of cumulative effects explained above, including climate change, and have concluded that even in light of the ongoing impacts of these activities and conditions; the conclusions reached above do not change. Based on the analysis presented herein, the proposed action, resulting in the mortality of one subadult CA DPS Atlantic sturgeon, is not likely to appreciably reduce the survival and recovery of this species.

10.1.5 South Atlantic DPS

We expect that 20% of the Atlantic sturgeon in the action area will originate from the SA DPS. The SA DPS is listed as endangered. The SA DPS consists of Atlantic sturgeon originating from at least six rivers where spawning is still thought to occur. An estimate of 343 spawning adults per year is available for the Altamaha River, GA, based on fishery-independent data collected in 2004 and 2005 (Schueller and Peterson, 2006); because males and females do not spawn every year, this estimate represents a portion of the total number of Altamaha adults. Males spawn every 1-5 years and females every 2-5 years; using this information and assuming a 1:1 sex ratio, we could estimate a total adult population size of 513-855 Altamaha River origin adults. Fisheries bycatch data suggests that the ratio of subadults to adults is at least 3:1. Therefore, we estimate that there are at least 1,539-2,565 Altamaha River origin subadults. The ASSRT estimated that there are less than 300 spawning adults (total of both sexes) in each of the other river systems where spawning occurs. There are no reported population estimates for any other spawning rivers or the DPS as a whole. South Atlantic DPS origin Atlantic sturgeon are affected by numerous sources of human induced mortality and habitat disturbance throughout the riverine and marine portions of their range. There is currently not enough information to establish a trend for any life stage, for any of the spawning populations or for the DPS as a whole. Here, we consider the effect of the loss of one subadult on the reproduction, numbers and distribution of the SA DPS.

The reproductive potential of the SA DPS will not be affected in any way other than through a reduction in numbers of individuals. The loss of this subadult would have the effect of reducing the amount of potential reproduction as any dead SA DPS Atlantic sturgeon would have no potential for future reproduction. This small reduction in potential future spawners is expected to result in an extremely small reduction in the number of eggs laid or larvae produced in future years and similarly, an extremely small effect on the strength of subsequent year classes. Even considering the potential future spawners that would be produced by the individual that would be killed as a result of the proposed action, any effect to future year classes is anticipated to be extremely small and would not change the status of this species. Additionally, we have determined that any impacts to behavior will be minor and temporary and that there will not be any delay or disruption of any normal behavior; there will also be no reduction in individual fitness or any future reduction in numbers of individuals. The proposed action will also not affect the spawning grounds within the rivers where SA DPS fish spawn. The action will also not create any barrier to pre-spawning sturgeon accessing the overwintering sites or the spawning grounds used by SA DPS fish.

The mortality of 1 subadult Atlantic sturgeon from the SA DPS represents a very small percentage of subadult population (*i.e.*, no more than 0.06% of the population, just considering the minimum

estimated number of Altamaha River origin subadults; the percentage would be much less if the number of adults, YOY and juveniles was considered as well as any fish from the five other spawning rivers). While the death of one subadult Atlantic sturgeon will reduce the number of SA DPS Atlantic sturgeon compared to the number that would have been present absent the proposed action, it is not likely that this reduction in numbers will change the status of this species as this loss represents a very small percentage of the subadult population and an even smaller percentage of the overall population of the DPS (juveniles, subadults and adults combined). Even when converting this fish to adult equivalents¹¹ (using a conversion rate of 0.48 considering the adult equivalent), and assuming no growth in the adult population, the mortality of 1 subadult represents an extremely small percentage of the adult population (no more than 0.09%, just considering the Altamaha River adults).

The proposed action is not likely to reduce distribution because the action will not impede Atlantic sturgeon from accessing any seasonal concentration areas, including foraging areas within the action area that may be used by SA DPS subadults or adults. Further, the action is not expected to reduce the river by river distribution of Atlantic sturgeon. Any effects to distribution will be minor and temporary and limited to the temporary avoidance of the immediate area where dredging is occurring.

Based on the information provided above, the death of no more than one SA DPS Atlantic sturgeon will not appreciably reduce the likelihood of survival of the SA DPS (*i.e.*, it will not decrease the likelihood that the species will continue to persist into the future with sufficient resilience to allow for the potential recovery from endangerment). The action will not affect SA DPS Atlantic sturgeon in a way that prevents the species from having a sufficient population, represented by all necessary age classes, genetic heterogeneity, and number of sexually mature individuals producing viable offspring, and it will not result in effects to the environment which would prevent Atlantic sturgeon from completing their entire life cycle, including reproduction, sustenance, and shelter. This is the case because: (1) the death of one subadult SA DPS Atlantic sturgeon represents an extremely small percentage of the species as a whole; (2) the death of 1 subadult SA DPS Atlantic sturgeon will not change the status or trends of any spawning river or the species as a whole; (3) the loss of one subadult SA DPS Atlantic sturgeon is not likely to have an effect on the levels of genetic heterogeneity in the population; (4) the loss of one subadult SA DPS Atlantic sturgeon is likely to have such a small effect on reproductive output that the loss of this individual will not change the status or trends of the species; (5) the action will have only a minor and temporary effect on the distribution of SA DPS Atlantic sturgeon in the action area and no effect on the distribution of the species throughout its range; and, (6) the action will have no effect on the ability of SA DPS Atlantic sturgeon to shelter and only an insignificant effect on individual foraging SA DPS Atlantic sturgeon.

In certain instances, an action that does not appreciably reduce the likelihood of a species' survival might affect its likelihood of recovery or the rate at which recovery is expected to occur. As explained above, we have determined that the proposed action will not appreciably reduce the likelihood that the SA DPS will survive in the wild. Here, we consider the potential for the action to reduce the likelihood of recovery. As noted above, recovery is defined as the improvement in

¹¹ The "adult equivalent" rate converts a number of subadults to adult equivalents (the number of subadults that would, through natural mortality, live to be adults; for Atlantic sturgeon, this is calculated as 0.48).

status such that listing is no longer appropriate. Thus, we have considered whether the proposed action will affect the likelihood that the SA DPS can rebuild to a point where listing is no longer appropriate. No Recovery Plan for the SA DPS has been published. The Recovery Plan will outline the steps necessary for recovery and the demographic criteria which once attained would allow the species to be delisted. We know that in general, to recover, a species must have a sustained positive trend over time and an increase in population. To allow those things to happen, a species must have enough habitat in suitable condition that allows all normal life functions to occur (i.e., spawning, foraging, resting) and have access to enough food. Here, we consider whether this proposed action will affect the population size and/or trend in a way that would affect the likelihood of recovery.

The proposed action is not expected to modify, curtail or destroy the range of the species since it will result in an extremely small reduction in the number of SA DPS Atlantic sturgeon and since it will not affect the overall distribution of SA DPS Atlantic sturgeon. Any effects to habitat will be insignificant and discountable and will not affect the ability of Atlantic sturgeon to carry out any necessary behaviors or functions. Any impacts to available forage will also be insignificant. The proposed action will result in an extremely small amount of mortality (one individual) and a subsequent small reduction in future reproductive output. For these reasons, it is not expected to affect the persistence of the SA DPS of Atlantic sturgeon. This action will not change the status or trend of the SA DPS of Atlantic sturgeon. The very small reduction in numbers and future reproduction resulting from the proposed action will not reduce the likelihood of improvement in the status of the SA DPS of Atlantic sturgeon. The effects of the proposed action will not delay the recovery timeline or otherwise decrease the likelihood of recovery. The effects of the proposed action will also not reduce the likelihood that the status of the species can improve to the point where it is recovered and could be delisted. Therefore, the proposed action will not appreciably reduce the likelihood that the SA DPS of Atlantic sturgeon can be brought to the point at which they are no longer listed as threatened. Based on the analysis presented herein, the proposed action, is not likely to appreciably reduce the survival and recovery of this species.

Despite the threats faced by individual SA DPS Atlantic sturgeon inside and outside of the action area, the proposed action will not increase the vulnerability of individual sturgeon to these additional threats and exposure to ongoing threats will not increase susceptibility to effects related to the proposed action. We have considered the effects of the proposed action in light of cumulative effects explained above, including climate change, and have concluded that even in light of the ongoing impacts of these activities and conditions; the conclusions reached above do not change. Based on the analysis presented herein, the proposed action, resulting in the mortality of one subadult SA DPS Atlantic sturgeon, is not likely to appreciably reduce the survival and recovery of this species.

10.2 Green sea turtles

In the “Effects of the Action” section above, we determined that green sea turtles could be entrained in a hopper dredge operating in any of the channels or borrow areas considered in this consultation. Based on a calculated entrainment rate of sea turtles for projects using hopper dredges in the action area, we estimate that 1 sea turtle is likely to be entrained for every 300,000 cy of material removed with a hopper dredge. Also, based on the ratio of sea turtles entrained in other hopper dredge operations in the action area, we estimate that 2% of the sea turtles entrained during project operations were likely to be greens. Based on this, we determined that, if a hopper dredge is used,

no more than one green sea turtle is likely to be entrained during the dredging of Sandbridge Shoal in 2012-2013 considered here. We determined that all other effects of the action on this species, including effects to habitat and prey due to dredging and dredge disposal, will be insignificant and discountable. If a cutterhead dredge is used or all hopper dredging is completed in December – March, no interactions with green sea turtles are likely.

Green sea turtles are listed as both threatened and endangered under the ESA. Breeding colony populations in Florida and on the Pacific coast of Mexico are considered endangered while all others are considered threatened. Due to the inability to distinguish between these populations away from the nesting beach, for this Opinion, green sea turtles are considered endangered wherever they occur in U.S. waters. Green sea turtles are distributed circumglobally and can be found in the Pacific, Indian, and Atlantic Oceans as well as the Mediterranean Sea (NMFS and USFWS 1991; Seminoff 2004; NMFS and USFWS 2007d). As is also the case with the other sea turtle species, green sea turtles face numerous threats on land and in the water that affect the survival of all age classes.

A review of 32 Index Sites distributed globally revealed a 48% to 67% decline in the number of mature females nesting annually over the last three generations (Seminoff 2004). For example, in the eastern Pacific, the main nesting sites for the green sea turtle are located in Michoacan, Mexico, and in the Galapagos Islands, Ecuador, where the number of nesting females exceeds 1,000 females per year at each site (NMFS and USFWS 2007d). Historically, however, greater than 20,000 females per year are believed to have nested in Michoacan alone (Cliffon *et al.* 1982; NMFS and USFWS 2007d). However, the decline is not consistent across all green sea turtle nesting areas. Increases in the number of nests counted and, presumably, the numbers of mature females laying nests were recorded for several areas (Seminoff 2004; NMFS and USFWS 2007d). Of the 32 index sites reviewed by Seminoff (2004), the trend in nesting was described as: increasing for 10 sites, decreasing for 19 sites, and stable (no change) for 3 sites. Of the 46 green sea turtle nesting sites reviewed for the 5-year status review, the trend in nesting was described as increasing for 12 sites, decreasing for 4 sites, stable for 10 sites, and unknown for 20 sites (NMFS and USFWS 2007d). The greatest abundance of green sea turtle nesting in the western Atlantic occurs on beaches in Tortuguero, Costa Rica (NMFS and USFWS 2007d). Nesting in the area has increased considerably since the 1970s and nest count data from 1999-2003 suggest nesting by 17,402-37,290 females per year (NMFS and USFWS 2007d). One of the largest nesting sites for green sea turtles worldwide is still believed to be on the beaches of Oman in the Indian Ocean (Hirth 1997; Ferreira *et al.* 2003; NMFS and USFWS 2007d). However, nesting data for this area has not been published since the 1980s and updated nest numbers are needed (NMFS and USFWS 2007d).

The results of genetic analyses show that green sea turtles in the Atlantic do not contribute to green sea turtle nesting elsewhere in the species' range (Bowen and Karl 2007). Therefore, increased nesting by green sea turtles in the Atlantic is not expected to affect green sea turtle abundance in other ocean basins in which the species occurs. However, the ESA-listing of green sea turtles as a species across ocean basins means that the effects of a proposed action must, ultimately, be considered at the species level for section 7 consultations. NMFS recognizes that the nest count data available for green sea turtles in the Atlantic clearly indicates increased nesting at many sites. However, NMFS also recognizes that the nest count data, including data for green sea turtles in the Atlantic, only provides information on the number of females currently nesting, and is not

necessarily a reflection of the number of mature females available to nest or the number of immature females that will reach maturity and nest in the future. Given the late age to maturity for green sea turtles (20 to 50 years) (Balazs 1982; Frazer and Ehrhart 1985; Seminoff 2004), caution is urged regarding the trend for any of the nesting groups since no area has a dataset spanning a full green sea turtle generation (NMFS and USFWS 2007d).

As described in the Status of the Species, Environmental Baseline and Cumulative Effects sections above, green sea turtles in the action area continue to be affected by multiple anthropogenic impacts including bycatch in commercial and recreational fisheries, habitat alteration and other factors that result in mortality of individuals at all life stages.

The lethal removal of one green sea turtle, whether male or female, immature or mature, would reduce the number of green sea turtles as compared to the number of green that would have been present in the absence of the proposed action assuming all other variables remained the same. However, this does not necessarily mean that the species will experience reductions in reproduction, numbers or distribution in response to these effects to the extent that survival and recovery would be appreciably reduced. The loss of one green sea turtles represents a very small percentage of the species as a whole. Even compared to the number of nesting females (17,000-37,000), which represent only a portion of the number of greens worldwide, the mortality of one green represents less than 0.006% of the population. The loss of this sea turtle would be expected to reduce the reproduction of green sea turtles as compared to the reproductive output of green sea turtles in the absence of the proposed action. As described in the “Status of the Species” section above, we consider the trend for green sea turtles to be stable. However, as explained below, the death of one green sea turtle will not appreciably reduce the likelihood of survival for the species for the following reasons.

While generally speaking, the loss of a small number of individuals from a subpopulation or species may have an appreciable reduction on the numbers, reproduction and distribution of the species this is likely to occur only when there are very few individuals in a population, the individuals occur in a very limited geographic range or the species has extremely low levels of genetic diversity. This situation is not likely in the case of greens because: the species is widely geographically distributed, it is not known to have low levels of genetic diversity, there are several thousand individuals in the population and the number of greens is likely to be increasing and at worst is stable. This action is not likely to reduce distribution of greens because the action will not impede greens from accessing foraging grounds or cause more than a temporary disruption to other migratory behaviors.

Based on the information provided above, the death of one green sea turtle will not appreciably reduce the likelihood of survival (i.e., it will not decrease the likelihood that the species will continue to persist into the future with sufficient resilience to allow for the potential recovery from endangerment). The action will not affect green sea turtles in a way that prevents the species from having a sufficient population, represented by all necessary age classes, genetic heterogeneity, and number of sexually mature individuals producing viable offspring and it will not result in effects to the environment which would prevent green sea turtles from completing their entire life cycle, including reproduction, sustenance, and shelter. This is the case because: (1) the species’ nesting trend is increasing; (2) the death of 1 green sea turtle represents an extremely small percentage of

the species as a whole; (3) the loss of 1 green sea turtle will not change the status or trends of the species as a whole; (4) the loss of 1 green sea turtles is not likely to have an effect on the levels of genetic heterogeneity in the population; (5) the loss of 1 green sea turtles is likely to have an undetectable effect on reproductive output of the species as a whole; (6) the action will have no effect on the distribution of greens in the action area or throughout its range; and (7) the action will have no effect on the ability of green sea turtles to shelter and only an insignificant effect on individual foraging green sea turtles.

In certain instances, an action may not appreciably reduce the likelihood of a species survival (persistence) but may affect its likelihood of recovery or the rate at which recovery is expected to occur. As explained above, we have determined that the proposed action will not appreciably reduce the likelihood that green sea turtles will survive in the wild. Here, we consider the potential for the action to reduce the likelihood of recovery. As noted above, recovery is defined as the improvement in status such that listing is no longer appropriate. Thus, we have considered whether the proposed action will affect the likelihood that the species can rebuild to a point where listing is no longer appropriate. A Recovery Plan for Green sea turtles was published by NMFS and USFWS in 1991. The plan outlines the steps necessary for recovery and the criteria which, once met, would ensure recovery. In order to be delisted, green sea turtles must experience sustained population growth, as measured in the number of nests laid per year, over time. Additionally, “priority one” recovery tasks must be achieved and nesting habitat must be protected (through public ownership of nesting beaches) and stage class mortality must be reduced. Here, we consider whether this proposed action will affect the population size and/or trend in a way that would affect the likelihood of recovery.

The proposed action will not appreciably reduce the likelihood of survival of green sea turtles. Also, it is not expected to modify, curtail or destroy the range of the species since it will result in an extremely small reduction in the number of green sea turtles in any geographic area and since it will not affect the overall distribution of green sea turtles other than to cause minor temporary adjustments in movements in the action area. As explained above, the proposed action is likely to result in the mortality of one green sea turtle; however, as explained above, the loss of these individuals over this time period is not expected to affect the persistence of green sea turtles or the species trend. The action will not affect nesting habitat and will have only an extremely small effect on mortality. The effects of the proposed action will not hasten the extinction timeline or otherwise increase the danger of extinction; further, the action will not prevent the species from growing in a way that leads to recovery and the action will not change the rate at which recovery can occur. This is the case because while the action may result in a small reduction in the number of greens and a small reduction in the amount of potential reproduction due to the loss of one individual, these effects will be undetectable over the long-term and the action is not expected to have long term impacts on the future growth of the population or its potential for recovery. Therefore, based on the analysis presented above, the proposed action will not appreciably reduce the likelihood that green sea turtles can be brought to the point at which they are no longer listed as endangered or threatened.

Despite the threats faced by individual green sea turtles inside and outside of the action area, the proposed action will not increase the vulnerability of individual sea turtles to these additional threats and exposure to ongoing threats will not increase susceptibility to effects related to the

proposed action. We have considered the effects of the proposed action in light of cumulative effects explained above, including climate change, and has concluded that even in light of the ongoing impacts of these activities and conditions; the conclusions reached above do not change. Based on the analysis presented herein, the proposed action, resulting in the mortality of one green sea turtle, is not likely to appreciably reduce the survival and recovery of this species.

10.3 Leatherback sea turtles

As noted in sections above, the physical disturbance of sediments and entrainment of associated benthic resources could reduce the availability of sea turtle prey in the affected areas, but these reductions will be localized and temporary, and foraging turtles are not likely to be limited by the reductions and any effects will be insignificant. Also, as explained above, no leatherback sea turtles are likely to be entrained in any dredge operating during any of the projects considered here and this species is not likely to be involved in any collision with a project vessel. As all effects to leatherback sea turtles from the proposed project are likely to be insignificant or discountable, this action is not likely to adversely affect this species.

10.4 Kemp's ridley sea turtles

In the "Effects of the Action" section above, we determined that Kemp's ridleys could be entrained in a hopper dredge working in Sandbridge Shoals between April and November. Based on a calculated entrainment rate of sea turtles for projects using hopper dredges in the action area, we estimate that 1 sea turtle is likely to be entrained for every 300,000 cy of material removed with a hopper dredge. Also, based on the ratio of loggerhead and Kemp's ridleys entrained in other hopper dredge operations in the action area, we estimate that no more than 8% of the sea turtles entrained during project operations were likely to be Kemp's ridleys with the remainder loggerheads and greens. As such, the proposed action is likely to result in the entrainment and mortality of no more than 1 Kemp's ridleys. If a cutterhead dredge is used, we do not anticipate any entrainment; we also do not anticipate any entrainment if dredging is completed December – March.

Kemp's Ridley sea turtles are listed as a single species classified as "endangered" under the ESA. Kemp's ridleys occur in the Atlantic Ocean and Gulf of Mexico. The only major nesting site for Kemp's ridleys is a single stretch of beach near Rancho Nuevo, Tamaulipas, Mexico (Carr 1963; USFWS and NMFS 1992; NMFS and USFWS 2007c).

Nest count data provides the best available information on the number of adult females nesting each year. As is the case with the other sea turtle species discussed above, nest count data must be interpreted with caution given that these estimates provide a minimum count of the number of nesting Kemp's ridley sea turtles. In addition, the estimates do not account for adult males or juveniles of either sex. Without information on the proportion of adult males to females, and the age structure of the Kemp's ridley population, nest counts cannot be used to estimate the total population size (Meylan 1982; Ross 1996; Zurita *et al.* 2003; Hawkes *et al.* 2005; letter to J. Lecky, NMFS Office of Protected Resources, from N. Thompson, NMFS Northeast Fisheries Science Center, December 4, 2007). Nevertheless, the nesting data does provide valuable information on the extent of Kemp's ridley nesting and the trend in the number of nests laid. Estimates of the adult female nesting population reached a low of approximately 250-300 in 1985 (USFWS and NMFS 1992; TEWG 2000). From 1985 to 1999, the number of nests observed at Rancho Nuevo and nearby beaches increased at a mean rate of 11.3% per year (TEWG 2000). Current estimates suggest an adult female population of 7,000-8,000 Kemp's ridleys (NMFS and USFWS 2007c).

The most recent review of the Kemp's ridleys suggests that this species is in the early stages of recovery (NMFS and USFWS 2007b). Nest count data indicate increased nesting and increased numbers of nesting females in the population. NMFS also takes into account a number of recent conservation actions including the protection of females, nests, and hatchlings on nesting beaches since the 1960s and the enhancement of survival in marine habitats through the implementation of TEDs in the early 1990s and a decrease in the amount of shrimping off the coast of Tamaulipas and in the Gulf of Mexico in general (NMFS and USFWS 2007b). We expect this increasing trend to continue over the time period considered in this Opinion.

The mortality of 1 Kemp's ridley represents a very small percentage of the Kemp's ridleys worldwide. Even taking into account just nesting females, the death of 1 Kemp's ridley represents less than 0.014% of the population. While the death of 1 Kemp's ridley will reduce the number of Kemp's ridleys compared to the number that would have been present absent the proposed action, it is not likely that this reduction in numbers will change the status of this species or its stable to increasing trend as this loss represents a very small percentage of the population. Reproductive potential of Kemp's ridleys is not expected to be affected in any other way other than through a reduction in numbers of individuals. A reduction in the number of Kemp's ridleys would have the effect of reducing the amount of potential reproduction as any dead Kemp's ridleys would have no potential for future reproduction. In 2006, the most recent year for which data is available, there were an estimated 7-8,000 nesting females. While the species is thought to be female biased, there are likely to be several thousand adult males as well. Given the number of nesting adults, it is unlikely that the loss of 1 Kemp's ridley would affect the success of nesting in any year. Additionally, this small reduction in potential nesters is expected to result in a small reduction in the number of eggs laid or hatchlings produced in future years and similarly, a very small effect on the strength of subsequent year classes. Even considering the potential future nesters that would be produced by the individuals that would be killed as a result of the proposed action, any effect to future year classes is anticipated to be very small and would not change the stable to increasing trend of this species. Additionally, the proposed action will not affect nesting beaches in any way or disrupt migratory movements in a way that hinders access to nesting beaches or otherwise delays nesting.

The proposed action is not likely to reduce distribution because the action will not impede Kemp's ridleys from accessing foraging grounds or cause more than a temporary disruption to other migratory behaviors. Additionally, given the small percentage of the species that will be killed as a result of the proposed action, there is not likely to be any loss of unique genetic haplotypes and no loss of genetic diversity.

The loss of a small number of individuals from a subpopulation or species may have an appreciable reduction on the numbers, reproduction and distribution of the species. This is likely to occur only when there are very few individuals in a population, the individuals occur in a very limited geographic range or the species has extremely low levels of genetic diversity. This situation is not likely in the case of Kemp's ridleys because: the species is widely geographically distributed, it is not known to have low levels of genetic diversity, there are several thousand individuals in the population and the number of Kemp's ridleys is likely to be increasing and, at worst, is stable.

Based on the information provided above, the death of 1 Kemp's ridley will not appreciably reduce the likelihood of survival (i.e., it will not decrease the likelihood that the species will continue to persist into the future with sufficient resilience to allow for the potential recovery from endangerment). The action will not affect Kemp's ridleys in a way that prevents the species from having a sufficient population, represented by all necessary age classes, genetic heterogeneity, and number of sexually mature individuals producing viable offspring and it will not result in effects to the environment which would prevent Kemp's ridleys from completing their entire life cycle, including reproduction, sustenance, and shelter. This is the case because: (1) the species' nesting trend is increasing; (2) the death of 1 Kemp's ridleys represents an extremely small percentage of the species as a whole; (3) the death of 1 Kemp's ridleys will not change the status or trends of the species as a whole; (4) the loss of these Kemp's ridleys is not likely to have an effect on the levels of genetic heterogeneity in the population; (5) the loss of this Kemp's ridleys is likely to have such a small effect on reproductive output that the loss of these individuals will not change the status or trends of the species; (5) the action will have only a minor and temporary effect on the distribution of Kemp's ridleys in the action area and no effect on the distribution of the species throughout its range; and, (6) the action will have no effect on the ability of Kemp's ridleys to shelter and only an insignificant effect on individual foraging Kemp's ridleys.

In certain instances, an action may not appreciably reduce the likelihood of a species survival (persistence) but may affect its likelihood of recovery or the rate at which recovery is expected to occur. As explained above, we have determined that the proposed action will not appreciably reduce the likelihood that green sea turtles will survive in the wild. Here, we consider the potential for the action to reduce the likelihood of recovery. As noted above, recovery is defined as the improvement in status such that listing is no longer appropriate. Thus, we have considered whether the proposed action will affect the likelihood that Kemp's ridleys can rebuild to a point where listing is no longer appropriate. In 2011, NMFS and the USFWS issued a recovery plan for Kemp's ridleys (NMFS and USFWS 2011). The plan includes a list of criteria necessary for recovery. These include:

1. An increase in the population size, specifically in relation to nesting females¹²;
2. An increase in the recruitment of hatchlings¹³;
3. An increase in the number of nests at the nesting beaches;
4. Preservation and maintenance of nesting beaches (i.e. Rancho Nuevo, Tepehuajes, and Playa Dos); and,
5. Maintenance of sufficient foraging, migratory, and inter-nesting habitat.

Kemp's ridleys have an increasing trend; as explained above, the loss of one Kemp's ridley during the proposed action will not affect the population trend. The number of Kemp's ridleys likely to die as a result of the proposed action is an extremely small percentage of the species. This loss will not affect the likelihood that the population will reach the size necessary for recovery or the rate at which recovery will occur. As such, the proposed action will not affect the likelihood that criteria one, two or three will be achieved or the timeline on which they will be achieved. The action area

¹² A population of at least 10,000 nesting females in a season (as measured by clutch frequency per female per season) distributed at the primary nesting beaches in Mexico (Rancho Nuevo, Tepehuajes, and Playa Dos) is attained in order for downlisting to occur; an average of 40,000 nesting females per season over a 6-year period by 2024 for delisting to occur.

¹³ Recruitment of at least 300,000 hatchlings to the marine environment per season at the three primary nesting beaches in Mexico (Rancho Nuevo, Tepehuajes, and Playa Dos).

does not include nesting beaches; therefore, the proposed action will have no effect on the likelihood that recovery criteria four will be met. All effects to habitat will be insignificant and discountable; therefore, the proposed action will have no effect on the likelihood that criteria five will be met.

The effects of the proposed action will not hasten the extinction timeline or otherwise increase the danger of extinction; further, the action will not prevent the species from growing in a way that leads to recovery and the action will not change the rate at which recovery can occur. This is the case because while the action may result in a small reduction in the number of Kemp's ridleys and a small reduction in the amount of potential reproduction due to the loss of one individual, these effects will be undetectable over the long-term and the action is not expected to have long term impacts on the future growth of the population or its potential for recovery. Therefore, based on the analysis presented above, the proposed action will not appreciably reduce the likelihood that Kemp's ridley sea turtles can be brought to the point at which they are no longer listed as endangered or threatened.

Despite the threats faced by individual Kemp's ridley sea turtles inside and outside of the action area, the proposed action will not increase the vulnerability of individual sea turtles to these additional threats and exposure to ongoing threats will not increase susceptibility to effects related to the proposed action. We have considered the effects of the proposed action in light of cumulative effects explained above, including climate change, and has concluded that even in light of the ongoing impacts of these activities and conditions; the conclusions reached above do not change. Based on the analysis presented herein, the proposed action, resulting in the mortality of one Kemp's ridley sea turtle, is not likely to appreciably reduce the survival and recovery of this species.

10.5 Northwest Atlantic DPS of Loggerhead sea turtles

In the "Effects of the Action" section above, we determined that loggerheads could be entrained in a hopper dredge operating in any of the channels or borrow areas considered in this consultation. Based on a calculated entrainment rate of sea turtles for projects using hopper dredges in the action area, we estimate that 1 sea turtle is likely to be entrained for every 300,000 cy of material removed with a hopper dredge. Also, based on the ratio of loggerhead and Kemp's ridleys entrained in other hopper dredge operations in the action area, we estimate that 90% of the sea turtles entrained during project operations were likely to be loggerheads. Based on this, we determined that up to six loggerheads could be entrained as a result of the proposed action. We determined that all other effects of the action on this species will be insignificant and discountable. No entrainment of loggerheads is anticipated if a cutterhead dredge is used or if all hopper dredging occurs between December and March. This number also assumes that all dredging occurs in the April – November time period when sea turtles are present in the action area; this number will be less if any dredging occurs outside of this time period. All other effects to loggerheads, including effects to habitat and prey due to dredging and dredge disposal, will be insignificant and discountable.

The Northwest Atlantic DPS of loggerhead sea turtles is listed as "threatened" under the ESA. It takes decades for loggerhead sea turtles to reach maturity. Once they have reached maturity, females typically lay multiple clutches of eggs within a season, but do not typically lay eggs every season (NMFS and USFWS 2008). There are many natural and anthropogenic factors affecting the

survival of loggerheads prior to their reaching maturity as well as for those adults who have reached maturity. As described in the Status of the Species, Environmental Baseline and Cumulative Effects sections above, loggerhead sea turtles in the action area continue to be affected by multiple anthropogenic impacts including bycatch in commercial and recreational fisheries, habitat alteration, dredging, power plant intakes and other factors that result in mortality of individuals at all life stages. Negative impacts causing death of various age classes occur both on land and in the water. Many actions have been taken to address known negative impacts to loggerhead sea turtles. However, many remain unaddressed, have not been sufficiently addressed, or have been addressed in some manner but whose success cannot be quantified.

The SEFSC (2009) estimated the number of adult females in the NWA DPS at 30,000, and if a 1:1 adult sex ratio is assumed, the result is 60,000 adults in this DPS. Based on the reviews of nesting data, as well as information on population abundance and trends, NMFS and USFWS determined in the September 2011 listing rule that the NWA DPS should be listed as threatened. They found that an endangered status for the NWA DPS was not warranted given the large size of the nesting population, the overall nesting population remains widespread, the trend for the nesting population appears to be stabilizing, and substantial conservation efforts are underway to address threats. This stable trend is expected to continue over the time period considered in this Opinion.

As stated above, we expect the lethal entrainment of up to six loggerheads. The lethal removal of up to six loggerhead sea turtles from the action area over this time period would be expected to reduce the number of loggerhead sea turtles from the recovery unit of which they originated as compared to the number of loggerheads that would have been present in the absence of the proposed action (assuming all other variables remained the same). However, this does not necessarily mean that these recovery units will experience reductions in reproduction, numbers or distribution in response to these effects to the extent that survival and recovery would be appreciably reduced. The final revised recovery plan for loggerheads compiled the most recent information on mean number of loggerhead nests and the approximated counts of nesting females per year for four of the five identified recovery units (i.e., nesting groups). They are: (1) for the NRU, a mean of 5,215 loggerhead nests per year with approximately 1,272 females nesting per year; (2) for the PFRU, a mean of 64,513 nests per year with approximately 15,735 females nesting per year; (3) for the DTRU, a mean of 246 nests per year with approximately 60 females nesting per year; and (4) for the NGMRU, a mean of 906 nests per year with approximately 221 females nesting per year. For the GCRU, the only estimate available for the number of loggerhead nests per year is from Quintana Roo, Yucatán, Mexico, where a range of 903-2,331 nests per year was estimated from 1987-2001 (NMFS and USFWS 2007a). There are no annual nest estimates available for the Yucatán since 2001 or for any other regions in the GCRU, nor are there any estimates of the number of nesting females per year for any nesting assemblage in this recovery unit.

It is likely that the loggerhead sea turtles in the action area originate from several of the recovery units. Limited information is available on the genetic makeup of sea turtles in the mid-Atlantic, where the majority of sea turtle interactions are expected to occur. Cohorts from each of the five western Atlantic subpopulations are expected to occur in the action area. Genetic analysis of samples collected from immature loggerhead sea turtles captured in pound nets in the Pamlico-Albemarle Estuarine Complex in North Carolina from September-December of 1995-1997

indicated that cohorts from all five western Atlantic subpopulations were present (Bass *et al.* 2004). In a separate study, genetic analysis of samples collected from loggerhead sea turtles from Massachusetts to Florida found that all five western Atlantic loggerhead subpopulations were represented (Bowen *et al.* 2004). Bass *et al.* (2004) found that 80 percent of the juveniles and sub-adults utilizing the foraging habitat originated from the south Florida nesting population, 12 percent from the northern subpopulation, 6 percent from the Yucatan subpopulation, and 2 percent from other rookeries. The previously defined loggerhead subpopulations do not share the exact delineations of the recovery units identified in the 2008 recovery plan. However, the PFRU encompasses both the south Florida and Florida panhandle subpopulations, the NRU is roughly equivalent to the northern nesting group, the Dry Tortugas subpopulation is equivalent to the DTRU, and the Yucatan subpopulation is included in the GCRU.

Based on the genetic analysis presented in Bass *et al.* (2004) and the small number of loggerheads from the DTRU or the NGMRU likely to occur in the action area it is extremely unlikely that the loggerheads likely to be killed during the deepening project will originate from either of these recovery units. The majority, at least 80% of the loggerheads killed, are likely to have originated from the PFRU, with the remainder from the NRU and GCRU. As such, of the 5 loggerheads likely to be killed, 3 are expected to be from the PFRU, with 1 from the NRU and 1 from the GCRU. Below, we consider the effects of these mortalities on these three recovery units and the species as a whole.

As noted above, the most recent population estimates indicate that there are approximately 15,735 females nesting annually in the PFRU and approximately 1,272 females nesting per year in the NRU. For the GCRU, the only estimate available for the number of loggerhead nests per year is from Quintana Roo, Yucatán, Mexico, where a range of 903-2,331 nests per year was estimated from 1987-2001 (NMFS and USFWS 2007a). There are no annual nest estimates available for the Yucatán since 2001 or for any other regions in the GCRU, nor are there any estimates of the number of nesting females per year for any nesting assemblage in this recovery unit; however, the 2008 recovery plan indicates that the Yucatan nesting aggregation has at least 1,000 nesting females annually. As the numbers outlined here are only for nesting females, the total number of loggerhead sea turtles in each recovery unit is likely significantly higher.

The loss of 3 loggerheads represents an extremely small percentage of the number of sea turtles in the PFRU. Even if the total population was limited to 15,735 loggerheads, the loss of 3 individuals would represent approximately 0.02% of the population. Similarly, the loss of 1 loggerhead from the NRU represents an extremely small percentage of the recovery unit. Even if the total population was limited to 1,272 sea turtles, the loss of 1 individual would represent approximately 0.3% of the population. The loss of 1 loggerhead from the GCRU, which is expected to support at least 1,000 nesting females, represents less than 0.1% of the population. The loss of such a small percentage of the individuals from any of these recovery units represents an even smaller percentage of the species as a whole. Considering the extremely small percentage of the populations that will be killed, it is unlikely that these deaths will have a detectable effect on the numbers and population trends of loggerheads in these recovery units or the number of loggerheads in the population as a whole.

All of the loggerheads that are expected to be killed will be juveniles. Thus, any effects on reproduction are limited to the loss of these individuals on their year class and the loss of future

reproductive potential. Given the number of nesting adults in each of these populations, it is unlikely that the expected loss of loggerheads would affect the success of nesting in any year. Additionally, this small reduction in potential nesters is expected to result in a small reduction in the number of eggs laid or hatchlings produced in future years and similarly, a very small effect on the strength of subsequent year classes. Even considering the potential future nesters that would be produced by the individuals that would be killed as a result of the proposed action, any effect to future year classes is anticipated to be very small and would not change the stable trend of this species. Additionally, the proposed action will not affect nesting beaches in any way or disrupt migratory movements in a way that hinders access to nesting beaches or otherwise delays nesting.

The proposed action is not likely to reduce distribution because the action will not impede loggerheads from accessing foraging grounds or cause more than a temporary disruption to other migratory behaviors. Additionally, given the small percentage of the species that will be killed as a result of the deepening and maintenance, there is not likely to be any loss of unique genetic haplotypes and no loss of genetic diversity.

While generally speaking, the loss of a small number of individuals from a subpopulation or species may have an appreciable reduction on the numbers, reproduction and distribution of the species this is likely to occur only when there are very few individuals in a population, the individuals occur in a very limited geographic range or the species has extremely low levels of genetic diversity. This situation is not likely in the case of loggerheads because: the species is widely geographically distributed, it is not known to have low levels of genetic diversity, there are several thousand individuals in the population and the number of loggerheads is likely to be stable or increasing over the time period considered here.

Based on the information provided above, the death of up to six loggerheads will not appreciably reduce the likelihood of survival (i.e., it will not decrease the likelihood that the species will continue to persist into the future with sufficient resilience to allow for the potential recovery from endangerment). The action will not affect loggerheads in a way that prevents the species from having a sufficient population, represented by all necessary age classes, genetic heterogeneity, and number of sexually mature individuals producing viable offspring and it will not result in effects to the environment which would prevent loggerheads from completing their entire life cycle, including reproduction, sustenance, and shelter. This is the case because: (1) the species' nesting trend is stabilizing; (2) the death of these loggerheads represents an extremely small percentage of the species as a whole; (3) the death of these loggerheads will not change the status or trends of the species as a whole; (4) the loss of these loggerheads is not likely to have an effect on the levels of genetic heterogeneity in the population; (5) the loss of these loggerheads is likely to have such a small effect on reproductive output that the loss of these individuals will not change the status or trends of the species; (5) the action will have only a minor and temporary effect on the distribution of loggerheads in the action area and no effect on the distribution of the species throughout its range; and, (6) the action will have no effect on the ability of loggerheads to shelter and only an insignificant effect on individual foraging loggerheads.

In certain instances, an action may not appreciably reduce the likelihood of a species survival (persistence) but may affect its likelihood of recovery or the rate at which recovery is expected to occur. As explained above, we have determined that the proposed action will not appreciably

reduce the likelihood that green sea turtles will survive in the wild. Here, we consider the potential for the action to reduce the likelihood of recovery. As noted above, recovery is defined as the improvement in status such that listing is no longer appropriate. Thus, we have considered whether the proposed action will affect the likelihood that the NWA DPS of loggerheads can rebuild to a point where listing is no longer appropriate. In 2008, NMFS and the USFWS issued a recovery plan for the Northwest Atlantic population of loggerheads (NMFS and USFWS 2008). The plan includes demographic recovery criteria as well as a list of tasks that must be accomplished. Demographic recovery criteria are included for each of the five recovery units. These criteria focus on sustained increases in the number of nests laid and the number of nesting females in each recovery unit, an increase in abundance on foraging grounds, and ensuring that trends in neritic strandings are not increasing at a rate greater than trends in in-water abundance. The recovery tasks focus on protecting habitats, minimizing and managing predation and disease, and minimizing anthropogenic mortalities.

Loggerheads have an increasing trend; as explained above, the loss of six loggerheads as a result of the proposed action will not affect the population trend. The number of loggerheads likely to die as a result of the proposed action is an extremely small percentage of any recovery unit or the DPS as a whole. This loss will not affect the likelihood that the population will reach the size necessary for recovery or the rate at which recovery will occur. As such, the proposed action will not affect the likelihood that the demographic criteria will be achieved or the timeline on which they will be achieved. The action area does not include nesting beaches; all effects to habitat will be insignificant and discountable; therefore, the proposed action will have no effect on the likelihood that habitat based recovery criteria will be achieved. The proposed action will also not affect the ability of any of the recovery tasks to be accomplished.

The effects of the proposed action will not hasten the extinction timeline or otherwise increase the danger of extinction; further, the action will not prevent the species from growing in a way that leads to recovery and the action will not change the rate at which recovery can occur.

In summary, the effects of the proposed action will not hasten the extinction timeline or otherwise increase the danger of extinction; further, the action will not prevent the species from growing in a way that leads to recovery and the action will not change the rate at which recovery can occur. This is the case because while the action may result in a small reduction in the number of loggerheads and a small reduction in the amount of potential reproduction due to the loss of these individuals, these effects will be undetectable over the long-term and the action is not expected to have long term impacts on the future growth of the population or its potential for recovery. Therefore, based on the analysis presented above, the proposed action will not appreciably reduce the likelihood that loggerhead sea turtles can be brought to the point at which they are no longer listed as endangered or threatened.

Despite the threats faced by individual loggerhead sea turtles inside and outside of the action area, the proposed action will not increase the vulnerability of individual sea turtles to these additional threats and exposure to ongoing threats will not increase susceptibility to effects related to the proposed action. We have considered the effects of the proposed action in light of other threats, including climate change, and have concluded that even in light of the ongoing impacts of these activities and conditions, the conclusions reached above do not change. Based on the analysis

presented herein, the proposed action is not likely to appreciably reduce the survival and recovery of the NWA DPS of loggerhead sea turtles.

11.0 CONCLUSION

After reviewing the best available information on the status of endangered and threatened species under our jurisdiction, the environmental baseline for the action area, the effects of the action, and the cumulative effects, it is NMFS' biological opinion that the proposed action may adversely affect but is not likely to jeopardize the continued existence of any DPS of Atlantic sturgeon, Kemp's ridley or green sea turtles or the Northwest Atlantic DPS of loggerhead sea turtles and is not likely to adversely affect leatherback or hawksbill sea turtles, shortnose sturgeon or any species of listed whale. Because no critical habitat is designated in the action area, none will be affected by the proposed action.

12.0 INCIDENTAL TAKE STATEMENT

Section 9 of the ESA prohibits the take of endangered species of fish and wildlife. "Fish and wildlife" is defined in the ESA "as any member of the animal kingdom, including without limitation any mammal, fish, bird (including any migratory, non-migratory, or endangered bird for which protection is also afforded by treaty or other international agreement), amphibian, reptile, mollusk, crustacean, arthropod or other invertebrate, and includes any part, product, egg, or offspring thereof, or the dead body or parts thereof." 16 U.S.C. 1532(8). "Take" is defined as to harass, harm, pursue, hunt, shoot, wound, kill, trap, capture or collect, or to attempt to engage in any such conduct. Harm is further defined by NMFS to include any act which actually kills or injures fish or wildlife. Such an act may include significant habitat modification or degradation that actually kills or injures fish or wildlife by significantly impairing essential behavioral patterns including breeding, spawning, rearing, migrating, feeding, or sheltering. Incidental take is defined as take that is incidental to, and not the purpose of, the carrying out of an otherwise lawful activity. "Otherwise lawful activities" are those actions that meet all State and Federal legal requirements except for the prohibition against taking in ESA Section 9 (51 FR 19936, June 3, 1986), which would include any state endangered species laws or regulations. Section 9(g) makes it unlawful for any person "to attempt to commit, solicit another to commit, or cause to be committed, any offense defined [in the ESA.]" 16 U.S.C. 1538(g). See also 16 U.S.C. 1532(13)(definition of "person"). Under the terms of section 7(b)(4) and section 7(o)(2), taking that is incidental to and not intended as part of the agency action is not considered to be prohibited under the ESA provided that such taking is in compliance with the terms and conditions of this Incidental Take Statement.

The measures described below are non-discretionary, and must be undertaken by USACE so that they become binding conditions for the exemption in section 7(o)(2) to apply. USACE has a continuing duty to regulate the activity covered by this Incidental Take Statement. If USACE (1) fails to assume and implement the terms and conditions or (2) fails to require any contractors to adhere to the terms and conditions of the Incidental Take Statement through enforceable terms that are added contracts or other documents as appropriate, the protective coverage of section 7(o)(2) may lapse. In order to monitor the impact of incidental take, USACE must report the progress of the action and its impact on the species to us as specified in the Incidental Take Statement [50 CFR §402.14(i)(3)] (See U.S. Fish and Wildlife Service and National Marine Fisheries Service's Joint Endangered Species Act Section 7 Consultation Handbook (1998) at 4-49).

12.1 Amount or Extent of Incidental Take

The proposed dredging to be carried out has the potential to result in the entrainment, and subsequent mortality, of sea turtles and Atlantic sturgeon. The amount of take is dependent on the dredge type used. If a cutterhead dredge is used, we do not anticipate any take of sea turtles and anticipate the lethal take of no more than 1 Atlantic sturgeon from either the NYB, GOM, SA, CA or CB DPS. If a hopper dredge is used we anticipate the lethal take of no more than 1 Atlantic sturgeon from either the NYB, GOM, SA, CA or CB DPS. If a hopper dredge is used between April 1 and November 30, we anticipate the lethal take of seven sea turtles. We expect that at least 90% of the sea turtles will be loggerheads, 8% will be Kemp's ridleys and 2% will be green. Therefore, we expect the entrainment of six loggerheads and one green or Kemp's ridley. The amount of anticipated take described here is exempted by this ITS.

When a hopper dredge is used, NMFS-approved endangered species observers are typically required on board the dredge to monitor for the entrainment of sea turtles and sturgeon. The endangered species observer program has been in place on hopper dredges since 1994 and is effective at monitoring take during hopper dredge operations. The use of observers relies on screening placed on the draghead being large enough to allow large sized pieces of biological material to pass through and be caught in cages that retain material that is then inspected by the observer. When UXO screening is in place on the draghead, the size of material that can pass through the dredge is significantly smaller, making detection by an observer extremely unlikely. As described in the Description of the Action, due to safety concerns, USACE is likely to require UXO screening for dredges working on Sandbridge Shoal. It is likely that only internal soft tissue (e.g., intestine) or small, fragmented, external parts (e.g., pieces of shell) of the crushed/impinged animal would be entrained. These parts are extremely unlikely to be detected by ESA observers, and if detected, are likely to be too small to be identifiable as a particular species (pers. comm. Chris Slay, Coast Wise Consulting, Inc.; Trish Bargo, East Coast Observers, Inc.; April 4, 2012).

Additionally, animals may impinge on the UXO screens. Animals impinged on the UXO screen may free or dislodge themselves from the screen once the suction of the dredge has been turned off. Animals that free themselves may suffer severe injuries that may result in death. As the entire interaction occurs underwater, it would not be observed by an on-board observer. As such, in these cases, we have determined that it is not reasonable and appropriate to require endangered species observers on the dredge. As there is no practical way for on board endangered species observers to monitor the impingement/entrainment of listed species during hopper dredging operations with UXO screening in place, we explored several alternatives, for monitoring the interactions as described below.

The USACE and NMFS considered the following alternatives to (1) monitor take of listed species during hopper dredge operations with UXO screening in place or (2) modify the activity to eliminate the potential for take, thereby eliminating the need to monitor take.

1. Install a camera near the draghead: A camera installed on a draghead would allow users at the surface to observe underwater interactions. However, there are technical challenges to using video, including visibility due to water clarity and available light, improper focus, inappropriate camera angle, and the range of the viewing field. The use of video would require additional resources, and it is unlikely that it would be effective for monitoring this

type of dredge work. For these dredges, turbidity levels (i.e., up to 450 mg/l) near the draghead while dredging operations are underway are too high to visually detect any animal impinged on or within the vicinity of the draghead. Therefore, this is not a reasonable and appropriate means to monitor take.

2. Use of sonar/fish finder: Sonar can be used to detect animals within the water and within the vicinity of the dredge. We concluded that sonar alone could not indicate the take of an individual animal or identify the species potentially being taken. As such, we concluded that the use of such devices would be inappropriate in monitoring for take.
3. Placement of observers on the shoreline: Observers placed on the shoreline may be able to detect stranded animals either in the water or on the shore. However, animals may not strand in the direct vicinity of the operation. Injured or deceased animal may not float to the surface immediately (i.e., it may take days for this to occur) or may drift far from the incident where injury occurred. Therefore, an injured or deceased stranded animal often cannot be definitively attributed to a specific action. As such, this is not a reasonable and appropriate means to monitor take.
4. Relocation trawling: While relocation could reduce the number of sea turtles and Atlantic sturgeon in the area being dredged and therefore minimize take, using relocation trawling would not serve to monitor the number of animals affected during dredging. Additionally, relocation trawling does not eliminate the potential for take so we could not require relocation trawling and assume that no interactions with the dredge would occur. Therefore, while this is a good method to minimize hopper dredge takes as it is not a reasonable and appropriate means to monitor take.
5. Time of year restriction: If there was a time of year when no listed species were likely to occur in the action area, dredging could be scheduled to occur in that time of year. This would eliminate the potential for take and negate the need for monitoring. However, because Atlantic sturgeon occur in the action area year round and safety and navigational concerns require dredging year-round, this is not practicable.
6. Use of alternate dredge types: The use of a mechanical dredge would eliminate the potential for sea turtle takes and would greatly reduce the number of Atlantic sturgeon takes; similar benefits could be obtained by requiring the use of a cutterhead dredge. However, the USACE chooses the type of dredge based on practical and technological constraints, including water depth, oceanic conditions, vessel traffic and maneuverability, substrate type and distance to the disposal area. Therefore, while use of alternate dredge types may minimize take, it is not practicable to require that mechanical or cutterhead dredges be used in all instances.

Both agencies agreed that none of these methods would serve to eliminate the potential for take or were reasonable or appropriate for monitoring take. In situations where individual takes cannot be observed, a proxy must be considered. This proxy must be rationally connected to the taking and provide an obvious threshold of exempted take that, if exceeded, provides a basis for reinitiating consultation. As explained in section 7.0 of this Opinion, the estimated number of sea turtles and

Atlantic sturgeon to be adversely affected by this action is related to the volume of material removed via dredge. Therefore, the volume of material removed from the action area can serve as a proxy for monitoring actual take. As explained in the Effects of the Action, one sea turtle is entrained for every 300,000 cy of material dredged; one Atlantic sturgeon is entrained for every 2 mcy. This estimate provides a proxy for monitoring the amount of incidental take during hopper dredging at Sandbridge Shoal when UXO screening is in place and direct observations of impingements cannot occur. This will be used as the primary method of determining whether incidental take has occurred; that is, we will consider that one sea turtle (Kemp's ridley or loggerhead) has been taken for every 300,000 cubic yards material removed during hopper dredging operations. Similarly, we will consider that one subadult Atlantic sturgeon has been taken for every 2 million cubic yards of material removed during hopper dredging operations or cutterhead dredge operations. In addition, there is a possibility that a sea turtle or an Atlantic sturgeon may remain impinged on UXO screens after the suction has been turned off. These animals can be visually observed, via a lookout, when the draghead is lifted above the water. Animals documented by the lookout on the draghead will be considered a take and this monitoring will be considered as a part of the monitoring of the actual take level. Similarly, should we receive any reports of injured or killed sea turtles or sturgeon in the area (i.e., via the STSSN) and necropsy documents that interactions with the hopper dredge operating during this project was the cause of death, we will consider those animals to be taken by this action.

The USACE expects to remove a total of 2 mcy of material from Sandbridge Shoal, resulting in the entrainment of seven sea turtles and one Atlantic sturgeon. As soon as seven sea turtles are observed or believed to be taken (e.g., seven takes via proxy or one observed impinged and six via proxy, etc.), any additional take of a sea turtle will be considered to exceed the exempted level of take. We expect exceedance of the exempted level of take to be unlikely given the conservative assumptions made in calculating this estimate, particularly the assumption that all hopper dredging would occur between April and November when it is much more likely that some, if not all dredging will occur outside of this time of year. Similarly, as we expect the mortality of one Atlantic sturgeon over the course of the project, should one Atlantic sturgeon be observed or should the estimated amount of material to be removed be exceeded, we will consider take to have been exceeded. However, like sea turtles, we do not expect this to occur given the very conservative assumptions that were included in the calculation of this level of expected take. Lookouts will be present on the vessel and volumes of material removed will be continuously monitored during hopper dredge operations. Therefore, take levels can be detected and assessed early in the project and, if needed, consultation can be reinitiated.

If a cutterhead dredge is used without UXO screening, inspectors will visually inspect the area where sand is being placed; this is expected to detect any Atlantic sturgeon entrained in the cutterhead dredge.

12.2 Reasonable and prudent measures

NMFS believes the following reasonable and prudent measures are necessary and appropriate to minimize and monitor impacts of incidental take resulting from the proposed action:

1. NMFS must be contacted prior to the commencement of dredging and again upon completion of the dredging activity.

2. If UXO screening is not used on the cutterhead dredge, an inspector, with sufficient training to identify sturgeon, must be present at the disposal site to conduct daily inspections for biological materials, including Atlantic sturgeon or sturgeon parts. The inspection schedule and procedures must be sufficient to ensure a high likelihood of documenting entrained sturgeon and must involve inspections of ponded areas and inspections at the area where water is discharged from the disposal site. This requirement applies regardless of time of year that dredging is occurring.
3. The USACE shall ensure that all hopper dredges are outfitted with state-of-the-art sea turtle deflectors on the draghead and operated in a manner that will reduce the risk of interactions with sea turtles.
4. For all hopper dredge operations where UXO screening is not in place, a NMFS-approved observer must be present on board the hopper dredge any time it is operating.
5. The USACE shall ensure that for all dredge operations where UXO screening is in place, a lookout/bridge watch, knowledgeable in listed species identification, will be present on board the hopper dredge at all times to inspect the draghead each time it is removed from the water.
6. For all hopper or cutterhead dredge operations where UXO screening is in place, USACE shall provide monthly reports to NMFS regarding the status of dredging and interactions or observations of listed species.
7. The USACE shall ensure that dredges are equipped and operated in a manner that provides endangered/threatened species observers with a reasonable opportunity for detecting interactions with listed species and that provides for handling, collection, and resuscitation of turtles injured during project activity. Full cooperation with the endangered/threatened species observer program is essential for compliance with the ITS.
8. The USACE shall ensure that all measures are taken to protect any turtles or sturgeon that survive entrainment in a hopper dredge.
9. All Atlantic sturgeon captured must have a fin clip taken for genetic analysis. This sample must be transferred to NMFS.
10. Any dead sturgeon must be transferred to NMFS or an appropriately permitted research facility NMFS will identify so that a necropsy can be undertaken to attempt to determine the cause of death. Sturgeon should be held in cold storage.
11. Any dead sea turtles must be held until proper disposal procedures can be discussed with NMFS. Turtles should be held in cold storage.
12. All sturgeon and turtle captures, injuries or mortalities associated with any dredging activity and any sturgeon and sea turtle sightings in the action area must be reported to NMFS within 24 hours.

12.3 Terms and conditions

In order to be exempt from prohibitions of section 9 of the ESA, the USACE must comply with the following terms and conditions, which implement the reasonable and prudent measures described above and outline required reporting/monitoring requirements. These terms and conditions are non-discretionary.

1. To implement RPM #1, the USACE must contact NMFS (Julie Crocker: by email (julie.crocker@noaa.gov) or phone (978) 282-8480 or (978)-281-9328)) within 3 days of the commencement of each dredging cycle and again within 3 days of the completion of dredging activity. This correspondence will serve both to alert NMFS of the commencement and cessation of dredging activities and to give NMFS an opportunity to provide USACE with any updated contact information or reporting forms.
2. To implement RPM #2, if UXO screening is not in place during cutterhead dredging, the USACE must require inspections at the disposal area at least four times a day in order to document any Atlantic sturgeon or their parts entrained in the dredge. The USACE must provide training in sturgeon identification to inspectors working at the dredge disposal site. Species identification must be verified by an expert.
3. To implement RPM #2, the USACE shall ensure that the disposal site is equipped and operated in a manner that provides the inspector with a reasonable opportunity for detecting interactions with listed species and that provides for handling and collection of listed species during project activity.
4. To implement RPM #3, hopper dredges must be equipped with the rigid deflector draghead as designed by the USACE Engineering Research and Development Center, formerly the Waterways Experimental Station (WES), or if that is unavailable, a rigid sea turtle deflector attached to the draghead. Deflectors must be checked and/or adjusted by a designated expert prior to a dredge operation to insure proper installment and operation during dredging. The deflector must be checked after every load throughout the dredge operation to ensure that proper installation is maintained. Since operator skill is important to the effectiveness of the WES-developed draghead, operators must be properly instructed in its use. Dredge inspectors must ensure that all measures to protect sea turtles are being followed during dredge operations.
5. To implement RPM #4, observer coverage on hopper dredges must be sufficient for 100% monitoring of hopper dredging operations. This monitoring coverage must involve the placement of a NMFS-approved observer on board the dredge for every day that dredging is occurring. The observer must work a shift schedule appropriate to allow for the observation of at least 50% of the dredge loads (e.g., 12 hours on, 12 hours off). The USACE must ensure that USACE dredge operators and/or any dredge contractor adhere to the attached "Monitoring Specifications for Hopper Dredges" with trained NMFS-approved observers, in accordance with the attached "Observer Protocol" and "Observer Criteria" (Appendix D). No observers can be deployed to the dredge site until USACE has written confirmation from NMFS that they have met the qualifications to be a "NMFS-approved observer" as outlined in Appendix D. If substitute observers are required during dredging operations, USACE

must ensure that NMFS approval is obtained before those observers are deployed on dredges.

6. To implement RPM #5, the lookout will inspect the draghead for impinged sea turtles or Atlantic sturgeon each time it is brought up from completing a dredge cycle. Should a sea turtle or Atlantic sturgeon be found impinged on the draghead, the incident should be recorded (Appendix H and/or G) and NMFS contacted.
7. To implement RPM #6, USACE will provide NMFS reports every 30 days, via email (Julie.Crocker@noaa.gov and incidental.take@noaa.gov) recording the days that dredging occurred, summaries of the bridge watch reports on draghead inspection, the volume of material removed during the previous 30 day period and any observations of listed species.
8. To implement RPM #7, the USACE shall require of the dredge operator that, when the observer is off watch, the cage shall not be opened unless it is clogged. The USACE shall also require that if it is necessary to clean the cage when the observer is off watch, any aquatic biological material is left in the cage for the observer to document and clear out when they return on duty. In addition, the observer shall be the only one allowed to clean off the overflow screen.
9. To implement RPM #7, if sea turtles are present during dredging or material transport, vessels transiting the area must post a bridge watch, avoid intentional approaches closer than 100 yards when in transit, and reduce speeds to below 4 knots if bridge watch identifies a listed species in the immediate vicinity of the dredge.
10. To implement RPM #7, the USACE must ensure that all contracted personnel involved in operating hopper dredges receive thorough training on measures of dredge operation that will minimize takes of sea turtles. Training shall include measures discussed in Appendix D.
11. To implement RPM #8, the procedures for handling live sea turtles must be followed in the unlikely event that a sea turtle survives entrainment in the dredge (Appendix E). Any live sturgeon must be photographed, weighed and measured if possible, and released immediately overboard while the dredge is not operating.
12. To implement RPM #9, the USACE must ensure that fin clips are taken (according to the procedure outlined in Appendix F) of any sturgeon captured during the project and that the fin clips are sent to NMFS for genetic analysis. Fin clips must be taken prior to preservation of other fish parts or whole bodies.
13. To implement RPM #10, in the event of any lethal takes of Atlantic sturgeon, any dead specimens or body parts must be photographed, measured, and preserved (refrigerate or freeze) until disposal procedures are discussed with NMFS. The form included as Appendix G (sturgeon salvage form) must be completed and submitted to NMFS.

14. To implement RPM #11, in the event of any lethal takes of sea turtles, any dead specimens or body parts must be photographed, measured, and preserved (refrigerate or freeze) until disposal procedures are discussed with NMFS.
15. To implement RPM #10, if a decomposed turtle or turtle part is entrained during dredging operations, an incident report must be completed and the specimen must be photographed. Any turtle parts that are considered ‘not fresh’ (i.e., they were obviously dead prior to the dredge take and USACE anticipates that they will not be counted towards the ITS) must be frozen and transported to a nearby stranding or rehabilitation facility for review. USACE must ensure that the observer submits the incident report for the decomposed turtle part, as well as photographs, to NMFS within 24 hours of the take (see Appendix H) and request concurrence that this take should not be attributed to the Incidental Take Statement. NMFS shall have the final say in determining if the take should count towards the Incidental Take Statement.
16. To implement RPM #12, the USACE must contact NMFS within 24 hours of any interactions with sturgeon or sea turtles, including non-lethal and lethal takes. NMFS will provide updated contact information when alerted of the start of dredging activity. Until alerted otherwise, the USACE should provide reports by e-mail (julie.crocker@noaa.gov) or phone (978) 282-8480 or the Section 7 Coordinator by phone (978)281-9328 or fax 978-281-9394). Take information should also be reported by e-mail to: incidental.take@noaa.gov.
17. To implement RPM #12, the USACE must photograph and measure any sturgeon or sea turtles observed during project operations (including whole sturgeon or sea turtles or body parts observed at the disposal location or on board the dredge, hopper or scow) and the corresponding form (Appendix H) must be completed and submitted to NMFS **within 24 hours** by fax (978-281-9394) or e-mail (incidental.take@noaa.gov).
18. To implement RPM #12, the USACE must submit a final report summarizing the results of dredging and any takes of listed species to NMFS within 30 working days of the completion of each dredging contract (by mail to the attention of the Section 7 Coordinator, NMFS Protected Resources Division, 55 Great Republic Drive, Gloucester, MA 01930).

The reasonable and prudent measures, with their implementing terms and conditions, are designed to minimize and monitor the impact of incidental take that might otherwise result from the proposed action. Specifically, these RPMs and Terms and Conditions will keep us informed of when and where dredging and blasting activities are taking place and will require USACE to report any take in a reasonable amount of time, as well as implement measures to monitor for entrainment during dredging. USACE has reviewed the RPMs and Terms and Conditions outlined above and has agreed to implement all of these measures as described herein and in the referenced Appendices. The discussion below explains why each of these RPMs and Terms and Conditions are necessary and appropriate to minimize or monitor the level of incidental take associated with the proposed action and how they represent only a minor change to the action as proposed by the USACE.

RPM #1 and its implementing Terms and Conditions are necessary and appropriate because they will serve to ensure that we are aware of the dates and locations of all dredging activities. This will

allow us to monitor the duration and seasonality of dredging activities as well as give us an opportunity to provide USACE with any updated contact information for NMFS staff. This is only a minor change because it is not expected to result in any delay to the project and will merely involve an occasional telephone call or e-mail between USACE and NMFS staff.

Several of the RPMs (#2,4 and 5 as well as the implementing Term and Conditions are necessary and appropriate because they require that USACE have sufficient observer coverage to ensure the detection of any interactions with listed species. This is necessary for the monitoring of the level of take associated with the proposed action. The inclusion of these RPMs and Terms and Conditions is only a minor change as the ACOE included some level of observer coverage in the original project description will represent only a small increase in the cost of the project and will not result in any delays. These also represent only a minor change as in many instances they serve to clarify the duties of the inspectors or observers.

RPM #3 and its implementing Term and Condition, is necessary and appropriate as the use of draghead deflectors is accepted standard practice for hopper dredges operating in places and at times of year when sea turtles are known to be present and has been documented to reduce the risk of entrainment for sea turtles, thereby minimizing the potential for take of these species. This represents only a minor change as all of the hopper dredges likely to be used for this project, already have draghead deflectors, dredge operators are already familiar with their use, and the use will not affect the efficiency of the dredging operation. Additionally, dredging in the action area is typically conducted with draghead deflectors in place.

RPM #6 and #9-12 and the implementing Terms and Conditions are necessary and appropriate to ensure the proper handling and documentation of any interactions with listed species as well as requiring that these interactions are reported to us in a timely manner with all of the necessary information. This is essential for monitoring the level of incidental take associated with the proposed action. These RPMs and Terms and Conditions represent only a minor change as compliance will not result in any increased cost, delay of the project or decrease in the efficiency of the dredging operations.

RPM #7 and its implementing Terms and Conditions are necessary and appropriate as they will require that dredge operators use best management practices, including slowing down to 4 knots should listed species be observed, that will minimize the likelihood of take. This represents only a minor change as following these procedures should not increase the cost of the dredging operation or result in any delays or reduction of efficiency of the dredging project.

RPM #8 and its implementing Terms and Conditions are necessary and appropriate to ensure that any sea turtles or sturgeon that survive entrainment in a dredge are given the maximum probability of remaining alive and not suffering additional injury or subsequent mortality through inappropriate handling. This represents only a minor change as following these procedures will not result in an increase in cost or any delays to the proposed project.

13.0 CONSERVATION RECOMMENDATIONS

In addition to Section 7(a)(2), which requires agencies to ensure that all projects will not jeopardize the continued existence of listed species, Section 7(a)(1) of the ESA places a responsibility on all federal agencies to “utilize their authorities in furtherance of the purposes of this Act by carrying out programs for the conservation of endangered species.” Conservation Recommendations are discretionary agency activities to minimize or avoid adverse effects of a proposed action on listed species or critical habitat, to help implement recovery plans, or to develop information. As such, NMFS recommends that the USACE consider the following Conservation Recommendations:

- (1) To the extent practicable, the USACE should avoid dredging in the spring (March-May) and fall (September – November) when listed species are most likely to occur in the action area.
- (2) The USACE should conduct studies in conjunction with cutterhead dredging where disposal occurs on the beach to assess the potential for improved screening to: (1) establish the type and size of biological material that may be entrained in the cutterhead dredge, and (2) verify that monitoring the disposal site without screening is providing an accurate assessment of entrained material.
- (3) The USACE should support studies to determine the effectiveness of using a sea turtle deflector to minimize the potential entrainment of sturgeon during hopper dredging.
- (4) The USACE should explore alternative means for monitoring for interactions with listed species when UXO screening is in place including exploring the potential for video or other electronic monitoring.

14.0 REINITIATION OF CONSULTATION

This concludes formal consultation on the proposed action. As provided in 50 CFR §402.16, reinitiation of formal consultation is required where discretionary federal agency involvement or control over the action has been retained (or is authorized by law) and if: (1) the amount or extent of taking specified in the incidental take statement is exceeded; (2) new information reveals effects of the action that may not have been previously considered; (3) the identified action is subsequently modified in a manner that causes an effect to listed species; or (4) a new species is listed or critical habitat designated that may be affected by the identified action. In instances where the amount or extent of incidental take is exceeded, Section 7 consultation must be reinitiated immediately.

15.0 LITERATURE CITED

Allen PJ, Nicholl M, Cole S, Vlazny A, Cech JJ Jr. 2006. Growth of larval to juvenile green sturgeon in elevated temperature regimes. *Trans Am Fish Soc* 135:89–96

Anchor Environmental. 2003. Literature review of effects of resuspended sediments due to dredging. June. 140pp.

Andrews, H.V., and K. Shanker. 2002. A significant population of leatherback turtles in the Indian Ocean. *Kachhapa* 6:19.

Andrews, H.V., S. Krishnan, and P. Biswas. 2002. Leatherback nesting in the Andaman and Nicobar Islands. *Kachhapa* 6:15-18.

Antonelis, G.A., J.D. Baker, T.C. Johanos, R.C. Braun and A.L. Harting. 2006. Hawaiian monk seal (*Monachus schauinslandi*): status and conservation issues. *Atoll Research Bulletin* 543: 75-101

ASMFC (Atlantic States Marine Fisheries Commission). 2002. Amendment 4 to the Interstate Fishery Management Plan for weakfish. Fishery Management Report No. 39. Washington, D.C.: Atlantic States Marine Fisheries Commission.

ASMFC (Atlantic States Marine Fisheries Commission). 2009. Atlantic Sturgeon. In: Atlantic Coast Diadromous Fish Habitat: A review of utilization, threats, recommendations for conservation and research needs. Habitat Management Series No. 9. Pp. 195-253.

ASSRT (Atlantic Sturgeon Status Review Team). 2007. Status review of Atlantic sturgeon (*Acipenser oxyrinchus oxyrinchus*). National Marine Fisheries Service. February 23, 2007. 188 pp.

Attrill, M.J., J. Wright, and M. Edwards. 2007. Climate-related increases in jellyfish frequency suggest a more gelatinous future for the North Sea. *Limnology and Oceanography* 52:480-485.

Avens, L., J.C. Taylor, L.R. Goshe, T.T. Jones, and M. Hastings. 2009. Use of skeletochronological analysis to estimate the age of leatherback sea turtles *Dermochelys coriacea* in the western North Atlantic. *Endangered Species Research* 8:165-177.

Ayers, M.A. et al. 1994. Sensitivity of Water Resources in the Delaware River Basin to Climate Variability and Change. USGS Water Supply Paper 2422. 21 pp.

Bain, M. B. 1997. Atlantic and shortnose sturgeons of the Hudson River: Common and Divergent Life History Attributes. *Environmental Biology of Fishes* 48: 347-358.

Bain, M., K. Arend, N. Haley, S. Hayes, J. Knight, S. Nack, D. Peterson, and M. Walsh. 1998a. Sturgeon of the Hudson River: Final Report on 1993-1996 Research. Prepared for The Hudson River Foundation by the Department of Natural Resources, Cornell University, Ithaca, New York.

Bain, M.B., N. Haley, D. Peterson, J. R. Waldman, and K. Arend. 2000. Harvest and habitats of Atlantic sturgeon *Acipenser oxyrinchus* Mitchell, 1815, in the Hudson River Estuary: Lessons for Sturgeon Conservation. *Instituto Espanol de Oceanografia. Boletin* 16: 43-53.

- Bain, Mark B., N. Haley, D. L. Peterson, K. K. Arend, K. E. Mills, P. J. Sullivan. 2007. Recovery of a US Endangered Fish. PLoS ONE 2(1): e168. doi:10.1371/journal.pone.0000168
- Bain, Mark B., N. Haley, D. L. Peterson, K. K. Arend, K. E. Mills, P. J. Sullivan. 2000. Annual meeting of American fisheries Society. EPRI-AFS Symposium: Biology, Management and Protection of Sturgeon. St. Louis, MO. 23-24 August 2000.
- Baker, J.D., C.L. Littnan, and D.W. Johnston. 2006. Potential effects of sea level rise on the terrestrial habitats of endangered and endemic megafauna in the Northwestern Hawaiian Islands. *Endangered Species Research* 2:21-30.
- Balazs, G.H. 1982. Growth rates of immature green turtles in the Hawaiian Archipelago, p. 117-125. In K.A. Bjorndal (ed.), *Biology and Conservation of Sea Turtles*. Smithsonian Institution Press, Washington, D.C.
- Balazs, G.H. 1985. Impact of ocean debris on marine turtles: entanglement and ingestion. U.S. Department of Commerce, NOAA Tech. Memo. NMFS-SWFSC-54:387-429.
- Baldwin, R., G.R. Hughes, and R.T. Prince. 2003. Loggerhead turtles in the Indian Ocean. Pages 218-232. In: A.B. Bolten and B.E. Witherington (eds.) *Loggerhead Sea Turtles*. Smithsonian Books, Washington, D.C. 319 pp.
- Bartol, S.M., J.A. Musick, and M.L. Lenhardt. 1999. Auditory evoked potentials of the loggerhead sea turtle (*Caretta caretta*). *Copeia*, 3: 836-840.
- Bass, A.L., S.P. Epperly, and J. Braun-McNeill. 2004. Multi-year analysis of stock composition of a loggerhead turtle (*Caretta caretta*) foraging habitat using maximum likelihood and Bayesian methods. *Conservation Genetics* 5:783-796.
- Bath, D.W., J.M. O'Conner, J.B. Albert and L.G. Arvidson. 1981. Development and identification of larval Atlantic sturgeon (*Acipenser oxyrinchus*) and shortnose sturgeon (*A. brevirostrum*) from the Hudson River estuary, New York. *Copeia* 1981:711-717.
- Beamesderfer, Raymond C.P. and Ruth A. Farr. 1997. Alternatives for the protection and restoration of sturgeons and their habitat. *Environmental Biology of Fishes* 48: 407-417.
- Belanger, S.E., J.L. Farris, D.S. Cherry, and J. Cairns, Jr. 1985. Sediment preference of the freshwater Asiatic clam, *Corbicula fluminea*. *The Nautilus* 99(2-3):66-73.
- Berlin, W.H., R.J. Hesselberg, and M.J. Mac. 1981. Chlorinated hydrocarbons as a factor in the reproduction and survival of lake trout (*Salvelinus namaycush*) in Lake Michigan. Technical Paper 105 of the U.S. Fish and Wildlife Service, 42 pages.
- Bigelow, H.B. and W.C. Schroeder. 1953. Sea Sturgeon. In: *Fishes of the Gulf of Maine*. Fishery Bulletin 74. Fishery Bulletin of the Fish and Wildlife Service, vol. 53.
- Bilkovic, D.M, Angstadt, K. and D. Stanhope. 2009. Atlantic Sturgeon Spawning Habitat on the James River, Virginia: Final Report to NOAA/NMFS Chesapeake Bay Office. Virginia Institute of Marine Science, Gloucester Point, Virginia.

Birstein, V.J., Bemis, W.E. and J.R. Waldman. 1997. The threatened status of acipenseriform species: a summary. *Environmental Biology of Fishes* 48: 427-435.

Bjork, M., F. Short, E. McLeod, and S. Beers. 2008. Managing seagrasses for resilience to climate change. IUCN, Gland.

Bjorndal, K.A. 1997. Foraging ecology and nutrition of sea turtles. Pages 199-233 In: Lutz, P.L. and J.A. Musick, eds., *The Biology of Sea Turtles*. CRC Press, New York. 432 pp.

Blalock, H.N., and J.J. Herod. 1999. A comparative study of stream habitat and substrate utilized by *Corbicula fluminea* in the New River, Florida. *Florida Scientist* 62:145-151.

Blumenthal, J.M., J.L. Solomon, C.D. Bell, T.J. Austin, G. Ebanks-Petrie, M.S. Coyne, A.C. Broderick, and B.J. Godley. 2006. Satellite tracking highlights the need for international cooperation in marine turtle management. *Endangered Species Research* 2:51-61.

Bolten, A.B. 2003. Variation in sea turtle life history patterns: neritic vs. oceanic developmental stages. Pages 243-257 in P.L. Lutz, J.A. Musick, and J. Wyneken, eds. *The Biology of Sea Turtles*, Vol. 2. Boca Raton, Florida: CRC Press.

Bolten, A.B., J.A. Wetherall, G.H. Balazs, and S.G. Pooley (compilers). 1996. Status of marine turtles in the Pacific Ocean relevant to incidental take in the Hawaii-based pelagic longline fishery. U.S. Dept. of Commerce, NOAA Technical Memorandum, NOAA-TM-NOAA Fisheries SWFSC-230.

Bolten, A.B., K.A. Bjorndal, H.R. Martins, T. Dellinger, M.J. Biscoito, S.E. Encalada, and B.W. Bowen. 1998. Transatlantic developmental migrations of loggerhead sea turtles demonstrated by mtDNA sequence analysis. *Ecological Applications* 8(1):1-7.

Boreman, J. 1997. Sensitivity of North American sturgeons and paddlefish to fishing mortality. *Environmental Biology of Fishes* 48: 399-405.

Borodin, N. 1925. Biological observations on the Atlantic sturgeon, *Acipenser sturio*. *Transactions of the American Fisheries Society* 55: 184-190.

Boulon, R., Jr. 2000. Trends in sea turtle strandings, U.S. Virgin Islands: 1982 to 1997. U.S. Department of Commerce, NOAA Technical Memorandum NMFS-SEFSC-436:261-263.

Bowen, B.W. 2003. What is a loggerhead turtle? The genetic perspective. Pages 7-27 in A.B. Bolten and B.E. Witherington, (eds). *Loggerhead Sea Turtles*. Washington, D.C.: Smithsonian Press.

Bowen, B.W. , A. L. Bass, S. Chow, M. Bostrom, K. A. Bjorndal, A. B. Bolten, T. Okuyama, B. M. Bolker, S. Epperley, E. Lacasella, D. Shaver, M. Dodd, S. R. Hopkins-Murphy, J. A. Musick, M. Swingle, K. Rankin-Baransky, W. Teas, W. N. Witzell, and P. H. Dutton. 1992. Natal homing in juvenile loggerhead turtles (*Caretta caretta*). *Molecular Ecology* (2004) 13: 3797-3808.

Bowen, B.W., A.L. Bass, L. Soares, and R.J. Toonen. 2005. Conservation implications of complex population structure: lessons from the loggerhead turtle (*Caretta caretta*). *Molecular Ecology* 14:2389-2402.

- Bowen, B.W., and S.A. Karl. 2007. Population genetics and phylogeography of sea turtles. *Molecular Ecology* 16:4886-4907.
- Boysen, K. A. and Hoover, J. J. (2009), Swimming performance of juvenile white sturgeon (*Acipenser transmontanus*): training and the probability of entrainment due to dredging. *Journal of Applied Ichthyology*, 25: 54–59.
- Braun, J., and S.P. Epperly. 1996. Aerial surveys for sea turtles in southern Georgia waters, June 1991. *Gulf of Mexico Science* 1996(1):39-44.
- Braun-McNeill, J. , C.R. Sasso, S.P.Epperly, C. Rivero. 2008. Feasibility of using sea surface temperature imagery to mitigate cheloniid sea turtle–fishery interactions off the coast of northeastern USA. *Endangered Species Research: Vol. 5: 257–266*, 2008.
- Braun-McNeill, J., and S.P. Epperly. 2004. Spatial and temporal distribution of sea turtles in the western North Atlantic and the U.S. Gulf of Mexico from Marine Recreational Fishery Statistics Survey (MRFSS). *Marine Fisheries Review* 64(4):50-56.
- Brewer, K., M. Gallagher, P. Regos, P. Isert, and J. Hall. 1993. Kuvlum #1 Exploration Prospect: Site Specific Monitoring Program, Final Report. Prepared by Coastal Offshore Pacific Corporation, Walnut Creek, CA, for ARCO Alaska, Inc., Anchorage, AK. 80pp.
- Brodeur, R.D., C.E. Mills, J.E. Overland, G.E. Walters, and J.D. Schumacher. 1999. Evidence for a substantial increase in gelatinous zooplankton in the Bering Sea, with possible links to climate change. *Fisheries Oceanography* 8(4):296-306.
- Brown, J.J. and G.W. Murphy. 2010. Atlantic sturgeon vessel strike mortalities in the Delaware River. *Fisheries* 35(2):72-83.
- Brundage, H. 1986. Radio tracking studies of shortnose sturgeon in the Delaware River for the Merrill Creek Reservoir Project, 1985 Progress Report. V.J. Schuler Associates, Inc.
- Brundage, H.M. and J. C. O’Herron. 2009. Investigations of juvenile shortnose and Atlantic sturgeons in the lower tidal Delaware River. *Bull. N.J. Acad. Sci.* 54(2), pp1-8. Weber, R.G. 2001. Preconstruction Horeshoe Crab Egg Density Monitoring and Habitat Availability at Kelly Island, Port Mahon and Broadkill Beach Study Areas, Delaware. Submitted to the USACE Philadelphia District. Available at: <http://www.nap.usace.army.mil/cenap-pl/b10.pdf>
- Brundage, H.M. and R.E. Meadows. 1982. The Atlantic sturgeon in the Delaware River estuary. *Fisheries Bulletin* 80:337-343.
- Brundage, H.M., III and R.E. Meadows. 1982a. Occurrence of the endangered shortnose sturgeon, *Acipenser brevirostrum*, in the Delaware River estuary. *Estuaries* 5:203-208.
- Bryant, L.P. 2008. Governor’s Commission on Climate Change. Final Report: A Climate Change Action Plan. Virginia Department of Environmental Quality.
- Burlas, M., G. L Ray, & D. Clarke. 2001. The New York District’s Biological Monitoring Program for the Atlantic Coast of New Jersey, Asbury Park to Manasquan Section Beach Erosion

Control Project. Final Report. U.S. Army Engineer District, New York and U.S. Army Engineer Research and Development Center, Waterways Experiment Station.

Burton, W. 1993. Effects of bucket dredging on water quality in the Delaware River and the potential for effects on fisheries resources. Prepared by Versar, Inc. for the Delaware Basin Fish and Wildlife Management Cooperative, unpublished report. 30 pp.

Burton, W.H. 1994. Assessment of the Effects of Construction of a Natural Gas Pipeline on American Shad and Smallmouth Bass Juveniles in the Delaware River. Prepared by Versar, Inc. for Transcontinental Gas Pipe Line Corporation.

Bushnoe, T. M., Musick, J.A. and D.S. Ha. 2005. Essential spawning and nursery habitat of Atlantic sturgeon (*Acipenser oxyrinchus*) in Virginia. Provided by Jack Musick, Virginia Institute of Marine Science, Gloucester Point, Virginia.

Caillouet, C., C.T. Fontaine, S.A. Manzella-Tirpak, and T.D. Williams. 1995. Growth of head-started Kemp's ridley sea turtles (*Lepidochelys kempi*) following release. *Chelonian Conservation and Biology*. 1(3):231-234.

Cameron, P., J. Berg, V. Dethlefsen, and H. Von Westernhagen. 1992. Developmental defects in pelagic embryos of several flatfish species in the southern north-sea. *Netherlands Journal of Sea Research* 29: 239-256.

Cameron, S. 2012. "Assessing the Impacts of Channel Dredging on Atlantic Sturgeon Movement and Behavior". Presented to the Virginia Atlantic Sturgeon Partnership Meeting. Charles City, Virginia. March 19, 2012.

Carlson, D.M., and K.W. Simpson. 1987. Gut contents of juvenile shortnose sturgeon in the upper Hudson estuary. *Copeia* 1987:796-802

Caron, F., D. Hatin, and R. Fortin. 2002. Biological characteristics of adult Atlantic sturgeon (*Acipenser oxyrinchus*) in the Saint Lawrence River estuary and the effectiveness of management rules. *Journal of Applied Ichthyology* 18: 580-585.

Carr, A.R. 1963. Pan specific reproductive convergence in *Lepidochelys kempi*. *Ergebn. Biol.* 26: 298-303.

Carreras, C., S. Pont, F. Maffucci, M. Pascual, A. Barceló, F. Bentivegna, L. Cardona, F. Alegre, M. SanFélix, G. Fernández, and A. Aguilar. 2006. Genetic structuring of immature loggerhead sea turtles (*Caretta caretta*) in the Mediterranean Sea reflects water circulation patterns. *Marine Biology* 149:1269-1279.

Casale, P., P. Nicolosi, D. Freggi, M. Turchetto, and R. Argano. 2003. Leatherback turtles (*Dermochelys coriacea*) in Italy and in the Mediterranean basin. *Herpetological Journal* 13: 135-139.

Castroviejo, J., J.B. Juste, J.P. Del Val, R. Castelo, and R. Gil. 1994. Diversity and status of sea turtle species in the Gulf of Guinea islands. *Biodiversity and Conservation* 3: 828-836.

Cetacean and Turtle Assessment Program (CeTAP). 1982. Final report of the cetacean and turtle assessment program, University of Rhode Island, to Bureau of Land Management, U.S. Department of the Interior. Ref. No. AA551-CT8-48. 568 pp.

Chan, E.H., and H.C. Liew. 1996. Decline of the leatherback population in Terengganu, Malaysia, 1956-1995. *Chelonian Conservation and Biology* 2(2): 192-203.

Chevalier, J., X. Desbois, and M. Girondot. 1999. The reason for the decline of leatherback turtles (*Dermochelys coriacea*) in French Guiana: a hypothesis p.79-88. In Miaud, C. and R. Guyétant (eds.), *Current Studies in Herpetology, Proceedings of the ninth ordinary general meeting of the Societas Europea Herpetologica*, 25-29 August 1998 Le Bourget du Lac, France.

Church, J., J.M. Gregory, P. Huybrechts, M. Kuhn, K. Lambeck, M.T. Nhuan, D. Qin, P.L. Woodworth. 2001. Changes in sea level. In: Houghton, J.T., Y. Ding, D.J. Griggs, M. Noguer, P.J. Vander Linden, X. Dai, K. Maskell, C.A. Johnson CA (eds.) *Climate change 2001: the scientific basis. Contribution of Working Group I to the Third Assessment Report of the Intergovernmental Panel on Climate Change*. Cambridge University Press, Cambridge, p 639–694

Clarke, D. 2011. Sturgeon Protection. Presented to the Dredged Material Assessment and Management Seminar 24-26 May, 2011 Jacksonville, FL

Clarke, D. G., and Wilber, D. H. 2000. Assessment of potential impacts of dredging operations due to sediment resuspension. DOER Technical Notes Collection. U.S. Army Engineer Research and Development Center, Vicksburg, MS.

Clausner, J.; Jones, D., 2004: Prediction of flow fields near the intakes of hydraulic dredges. Web based tool. Dredging Operation and Environmental Research (DOER) Program. U.S. Army Engineer Research and Development Center, Vicksburg, MS. Available at: <http://el.erd.c.usace.army.mil/dots/doer/flowfields/dtb350.html>

Cliffton, K., D.O. Cornejo, and R.S. Felger. 1982. Sea turtles of the Pacific coast of Mexico. Pages 199-209 in K.A. Bjorndal, ed. *Biology and Conservation of Sea Turtles*. Washington, D.C.: Smithsonian Institution Press.

Colligan, M., Collins, M., Hecht, A., Hendrix, M., Kahnle, A., Laney, W., St. Pierre, R., Santos, R., and Squiers, T. 1998. Status Review of Atlantic sturgeon (*Acipenser oxyrinchus oxyrinchus*). U.S. Department of the Interior and U.S. Department of Commerce.

Collins, M. R., and T. I. J. Smith. 1997. Distribution of shortnose and Atlantic sturgeons in South Carolina. *North American Journal of Fisheries Management* 17: 995-1000.

Collins, M. R., S. G. Rogers, and T. I. J. Smith. 1996. Bycatch of sturgeons along the Southern Atlantic Coast of the USA. *North American Journal of Fisheries Management* 16: 24-29.

Collins, M.R., T.I.J. Smith, W.C. Post, and O. Pashuk. 2000. Habitat Utilization and Biological Characteristics of Adult Atlantic Sturgeon in Two South Carolina Rivers. *Transactions of the American Fisheries Society* 129: 982–988.

Conant, T.A., P.H. Dutton, T. Eguchi, S.P. Epperly, C.C. Fahy, M.H. Godfrey, S.L. MacPherson, E.E. Possardt, B.A. Schroeder, J.A. Seminoff, M.L. Snover, C.M. Upton, and B.E. Witherington. 2009. Loggerhead sea turtle (*Caretta caretta*) 2009 status review under the U.S. Endangered Species Act. Report of the Loggerhead Biological Review Team to the National Marine Fisheries Service, August 2009. 222 pp.

Coutant, C.C., 1987. Thermal preference: when does an asset become a liability? *Environmental Biology of Fishes* 18:161-172.

Coyne, M. and A.M. Landry, Jr. 2007. Population sex ratios and its impact on population models. In: Plotkin, P.T. (editor). *Biology and Conservation of Ridley Sea Turtles*. Johns Hopkins University Press, Baltimore, Maryland. p. 191-211.

Coyne, M.S. 2000. Population Sex Ratio of the Kemp's Ridley Sea Turtle (*Lepidochelys kempii*): Problems in Population Modeling. PhD Thesis, Texas A&M University. 136pp.

Crance, J. H. 1987. Habitat suitability index curves for anadromous fishes. In: *Common Strategies of Anadromous and Catadromous Fishes*, M. J. Dadswell (ed.). Bethesda, Maryland, American Fisheries Society. Symposium 1: 554.

Dadswell, M. 2006. A review of the status of Atlantic sturgeon in Canada, with comparisons to populations in the United States and Europe. *Fisheries* 31: 218-229.

Damon-Randall, K. et al. 2010. Atlantic sturgeon research techniques. NOAA Technical Memorandum NMFS-NE-215. Available at: http://www.nero.noaa.gov/prot_res/atlsturgeon/tm215.pdf

Damon-Randall, K., M. Colligan, and J. Crocker. 2012. Composition of Atlantic Sturgeon in Rivers, Estuaries, and in Marine Waters. National Marine Fisheries Service, NERO, Unpublished Report. 32 pages.

Daniels, R.C., T.W. White, and K.K. Chapman. 1993. Sea-level rise: destruction of threatened and endangered species habitat in South Carolina. *Environmental Management* 17(3):373-385.

Davenport, J. 1997. Temperature and the life-history strategies of sea turtles. *Journal of Thermal Biology* 22(6):479-488.

Davenport, J., and G.H. Balazs. 1991. 'Fiery bodies' – Are pyrosomas an important component of the diet of leatherback turtles? *British Herpetological Society Bulletin* 37: 33-38.

Dees, L. T. 1961. Sturgeons. United States Department of the Interior Fish and Wildlife Service, Bureau of Commercial Fisheries, Washington, D.C.

DFO (Fisheries and Oceans Canada). 2011. Atlantic sturgeon and shortnose sturgeon. Fisheries and Oceans Canada, Maritimes Region. Summary Report. U.S. Sturgeon Workshop, Alexandria, VA, 8-10 February, 2011. 11pp.

Diaz, R.J. 1994. Response of tidal freshwater macrobenthos to sediment disturbance. *Hydrobiologia* 278: 201-212.

Dodd, C.K. 1988. Synopsis of the biological data on the loggerhead sea turtle *Caretta caretta* (Linnaeus 1758). U.S. Fish and Wildlife Service Biological Report 88(14):1-110.

Dodd, M. 2003. Northern Recovery Unit - Nesting Female Abundance and Population Trends. Presentation to the Atlantic Loggerhead Sea Turtle Recovery Team, April 2003.

Doughty, R.W. 1984. Sea turtles in Texas: A forgotten commerce. *Southwestern Historical Quarterly*. pp. 43-70.

Dovel, W. L. and T. J. Berggren. 1983. Atlantic sturgeon of the Hudson River Estuary, New York. *New York Fish and Game Journal* 30: 140-172.

Dovel, W.J. 1978. The Biology and management of shortnose and Atlantic sturgeons of the Hudson River. Performance report for the period April 1, to September 30, 1978. Submitted to N.Y. State Department of Environmental Conservation.

Dovel, W.J. 1979. Biology and management of shortnose and Atlantic sturgeon of the Hudson River. New York State Department of Environmental Conservation, AFS9-R, Albany.

Duarte, C.M. 2002. The future of seagrass meadows. *Environmental Conservation* 29:192-206.

Dunton, K.J., A. Jordaan, K.A. McKown, D.O. Conover, and M.J. Frisk. 2010. Abundance and distribution of Atlantic sturgeon (*Acipenser oxyrinchus oxyrinchus*) within the Northwest Atlantic Ocean, determined from five fishery-independent surveys. *Fishery Bulletin* 108:450-465.

Durbin, E, G. Teegarden, R. Campbell, A. Cembella, M.F. Baumgartner, B.R. Mate. 2002. North Atlantic right whales, *Eubalaena glacialis*, exposed to Paralytic Shellfish Poisoning (PSP) toxins via a zooplankton vector, *Calanus finmarchicus*. *Harmful Algae* 1: 243-251.

Dutton, P.H., B.W. Bowen, D.W. Owens, A. Barragan, and S.K. Davis. 1999. Global phylogeography of the leatherback turtle (*Dermodochelys coriacea*). *Journal of Zoology* 248: 397-409.

Dutton, P.H., C. Hitipeuw, M. Zein, S.R. Benson, G. Petro, J. Pita, V. Rei, L. Ambio, and J. Bakarbessy. 2007. Status and genetic structure of nesting populations of leatherback turtles (*Dermodochelys coriacea*) in the Western Pacific. *Chelonian Conservation and Biology* 6(1):47-53.

Dwyer, F. James, Douglas K. Hardesty, Christopher G. Ingersoll, James L. Kunz, and David W. Whites. 2000. Assessing contaminant sensitivity of American shad, Atlantic sturgeon, and shortnose sturgeon. Final Report. U.S. Geological Survey. Columbia Environmental Research Center, 4200 New Have Road, Columbia, Missouri.

Dwyer, K.L., C.E. Ryder, and R. Prescott. 2002. Anthropogenic mortality of leatherback sea turtles in Massachusetts waters. Poster presentation for the 2002 Northeast Stranding Network Symposium.

Eckert, S.A. 1999. Global distribution of juvenile leatherback turtles. Hubbs Sea World Research Institute Technical Report 99-294.

Eckert, S.A. and J. Lien. 1999. Recommendations for eliminating incidental capture and mortality of leatherback sea turtles, *Dermochelys coriacea*, by commercial fisheries in Trinidad and Tobago. A report to the Wider Caribbean Sea Turtle Conservation Network (WIDECAST). Hubbs-Sea World Research Institute Technical Report No. 2000-310, 7 pp.

Eckert, S.A., D. Bagley, S. Kubis, L. Ehrhart, C. Johnson, K. Stewart, and D. DeFreese. 2006. Internesting and postnesting movements of foraging habitats of leatherback sea turtles (*Dermochelys coriacea*) nesting in Florida. *Chel. Cons. Biol.* 5(2): 239-248.

Ehrhart, L.M., D.A. Bagley, and W.E. Redfoot. 2003. Loggerhead turtles in the Atlantic Ocean: geographic distribution, abundance, and population status. Pages 157-174 in A.B. Bolten and B.E. Witherington, eds. *Loggerhead Sea Turtles*. Washington, D.C.: Smithsonian Institution Press.

Ehrhart, L.M., W.E. Redfoot, and D.A. Bagley. 2007. Marine turtles of the central region of the Indian River Lagoon System, Florida. *Florida Scientist* 70(4): 415-434.

Encyclopedia Britannica. 2010. Neritic Zone. Accessed 12 January 2010.
<http://www.britannica.com/eb/article-9055318>.

Environmental Protection Agency (EPA). 1986. Quality Criteria for Water. EPA 440/5-86-001.

Epperly, S., L. Avens, L. Garrison, T. Henwood, W. Hoggard, J. Mitchell, J. Nance, J. Poffenberger, C. Sasso, E. Scott-Denton, and C. Yeung. 2002. Analysis of sea turtle bycatch in the commercial shrimp fisheries of southeast U.S. waters and the Gulf of Mexico. U.S. Department of Commerce, NOAA Tech. Memo. NMFS-SEFSC-490, 88pp.

Epperly, S.P. 2003. Fisheries-related mortality and turtle excluder devices. In: P.L. Lutz, J.A.

Epperly, S.P. and J. Braun-McNeill. 2002. The use of AVHRR imagery and the management of sea turtle interactions in the Mid-Atlantic Bight. National Marine Fisheries Service, Southeast Fisheries Science Center, Miami, FL. 8pp.

Epperly, S.P., and W.G. Teas. 2002. Turtle Excluder Devices - Are the escape openings large enough? *Fishery Bulletin* 100:466-474.

Epperly, S.P., J. Braun, A.J. Chester, F.A. Cross, J.V. Merriner and P.A. Tester. 1995b. Winter distribution of sea turtles in the vicinity of Cape Hatteras and their interactions with the summer flounder trawl fishery. *Bull. of Marine Sci.* 56(2): 547-568.

Epperly, S.P., J. Braun, and A. Veishlow. 1995c. Sea turtles in North Carolina waters. *Conservation Biology* 9(2):384-394.

Epperly, S.P., J. Braun, and A.J. Chester. 1995a. Aerial surveys for sea turtles in North Carolina inshore waters. *Fishery Bulletin* 93:254-261.

Epperly, S.P., J. Braun-McNeill, and P.M. Richards. 2007. Trends in catch rates of sea turtles in North Carolina, USA. *Endangered Species Research* 3: 283-293.

ERC (Environmental Research and Consulting, Inc.) 2012. Acoustic telemetry study of the movements of juvenile sturgeons in reach B of the Delaware River during dredging operations. Prepared for the US Army Corps of Engineers. 38 pp.

ERC, Inc. (Environmental Research and Consulting, Inc.). 2002. Contaminant analysis of tissues from two shortnose sturgeon (*Acipenser brevirostrum*) collected in the Delaware River. Prepared for National Marine Fisheries Service. 16 pp. + appendices.

ERC, Inc. (Environmental Research and Consulting, Inc.). 2007. Preliminary acoustic tracking study of juvenile shortnose sturgeon and Atlantic sturgeon in the Delaware River. May 2006 through March 2007. Prepared for NOAA Fisheries. 9 pp.

Erickson, D. L., A. Kahnle, M. J. Millard, E. A. Mora, M. Bryja, A. Higgs, J. Mohler, M. DuFour, G. Kenney, J. Sweka, and E. K. Pikitch. 2011. Use of pop-up satellite archival tags to identify oceanic-migratory patterns for adult Atlantic Sturgeon, *Acipenser oxyrinchus oxyrinchus* Mitchell, 1815. *J. Appl. Ichthyol.* 27: 356–365.

Ernst, C.H. and R.W. Barbour. 1972. *Turtles of the United States*. Univ. Press of Kentucky, Lexington. 347 pp.

Eyler, S., M. Mangold, and S. Minkinen. 2004. Atlantic coast sturgeon tagging database. USFWS, Maryland Fishery Resources Office. Summary Report. 60 pp.

Eyler, Sheila M., Jorgen E. Skjveland, Michael F. Mangold, and Stuart A. Welsh. 2000. Distribution of Sturgeons in Candidate Open Water Dredged Material Placement Sites in the Potomac River (1998-2000). U.S. Fish and Wildlife Service, Annapolis, MD. 26 pp.

Fernandes, S.J. 2008. Population demography, distribution, and movement patterns of Atlantic and shortnose sturgeons in the Penobscot River estuary, Maine. University of Maine. Masters thesis. 88 pp.

Ferreira, M.B., M. Garcia, and A. Al-Kiyumi. 2003. Human and natural threats to the green turtles, *Chelonia mydas*, at Ra's al Hadd turtle reserve, Arabian Sea, Sultanate of Oman. Page 142 in J.A. Seminoff, compiler. Proceedings of the Twenty-Second Annual Symposium on Sea Turtle Biology and Conservation. NOAA Technical Memorandum NMFS-SEFSC-503.

Finkbeiner, E.M., B.P. Wallace, J.E. Moore, R.L. Lewison, L.B. Crowder, and A.J. Read. 2011. Cumulative estimates of sea turtle bycatch and mortality in USA fisheries between 1990 and 2007. *Biological Conservation* 144(11): 2719-2727.

Fish, M.R., I.M. Cote, J.A. Gill, A.P. Jones, S. Renshoff, and A.R. Watkinson. 2005. Predicting the impact of sea-level rise on Caribbean sea turtle nesting habitat. *Conservation Biology* 19:482-491.

Flournoy, P.H., S.G. Rogers, and P.S. Crawford. 1992. Restoration of shortnose sturgeon in the Altamaha River, Georgia. Final Report to the U.S. Fish and Wildlife Service, Atlanta, Georgia.

Fox, D.A. and M.W. Breece. 2010. Atlantic sturgeon (*Acipenser oxyrinchus oxyrinchus*) in the New York Bight DPS: Identification of critical habitat and rates of interbasin exchange; Final Report Submitted to NOAA (Award NA08NMF4050611). 62 p.

- FPL (Florida Power and Light Company) and Quantum Resources. 2005. Florida Power and Light Company, St. Lucie Plant Annual Environmental Operating Report, 2002. 57 pp.
- Frazer, N.B., and L.M. Ehrhart. 1985. Preliminary growth models for green, *Chelonia mydas*, and loggerhead, *Caretta caretta*, turtles in the wild. *Copeia* 1985: 73-79.
- Fritts, T.H. 1982. Plastic bags in the intestinal tracts of leatherback marine turtles. *Herpetological Review* 13(3): 72-73. 2003. 9pp.
- Gagosian, R.B. 2003. Abrupt climate change: should we be worried? Prepared for a panel on abrupt climate change at the World Economic Forum, Davos, Switzerland, January 27,
- Garner, J.A, and S.A. Garner. 2007. Tagging and nesting research of leatherback sea turtles (*Dermochelys coriacea*) on Sandy Point St. Croix, U.S. Virgin Islands. Annual Report to U.S. Fish and Wildlife Service. WIMARCS Publication.
- Garrison, L.P., and L. Stokes. 2012. Estimated bycatch of marine mammals and sea turtles in the U.S. Atlantic pelagic longline fleet during 2010. NOAA Technical Memorandum NMFS-SEFSC-624:1-53.
- GCRP (U.S. Global Change Research Program). 2009. Global Climate Change Impacts in the United States. <http://www.globalchange.gov/usimpacts>
- Geoghegan, P., M.T. Mattson and R.G Keppel. 1992. Distribution of shortnose sturgeon in the Hudson River, 1984-1988. IN *Estuarine Research in the 1980s*, C. Lavett Smith, Editor. Hudson River Environmental Society, Seventh symposium on Hudson River ecology. State University of New York Press, Albany NY, USA.
- George, R.H. 1997. Health Problems and Diseases of Sea Turtles. Pages 363-386 in P.L. Lutz and J.A. Musick, eds. *The Biology of Sea Turtles*. Boca Raton, Florida: CRC Press.
- Germano, J. D., and Cary, D. 2005. "Rates and effects of sedimentation in the context of dredging and dredged material placement," *DOER Technical Notes Collection* (ERDC TN-DOER-E19), U.S. Army Engineer Research and Development Center, Vicksburg, MS.
- GHD. 2005. Port of Hay Point Apron Areas and Departure Path Capital Dredging: Draft EIS. GHD Pty Ltd.
- Giesy, J.P., J. Newsted, and D.L. Garling. 1986. Relationships between chlorinated hydrocarbon concentrations and rearing mortality of chinook salmon (*Oncorhynchus tshawytscha*) eggs from Lake Michigan. *Journal of Great Lakes Research* 12(1):82-98.
- Gilbert, C.R. 1989. Atlantic and shortnose sturgeons. United States Department of Interior Biological Report 82, 28 pages.
- Girondot, M. and J. Fretey. 1996. Leatherback turtles, *Dermochelys coriacea*, nesting in French Guiana 1978-1995. *Chelonian Conserv Biol* 2: 204-208.

- Girondot, M., M.H. Godfrey, L. Ponge, and P. Rivalan. 2007. Modeling approaches to quantify leatherback nesting trends in French Guiana and Suriname. *Chelonian Conservation and Biology* 6(1): 37-46.
- Glen, F. and N. Mrosovsky. 2004. Antigua revisited: the impact of climate change on sand and nest temperatures at a hawksbill turtle (*Eretmochelys imbricata*) nesting beach. *Global Change Biology* 10:2036-2045.
- Glen, F., A.C. Broderick, B.J. Godley, and G.C. Hays. 2003. Incubation environment affects phenotype of naturally incubated green turtle hatchlings. *Journal of the Marine Biological Association of the United Kingdom* 83(5): 1183-1186.
- GMFMC (Gulf of Mexico Fishery Management Council). 2007. Amendment 27 to the Reef Fish FMP and Amendment 14 to the Shrimp FMP to end overfishing and rebuild the red snapper stock. Tampa, Florida: Gulf of Mexico Fishery Management Council. 490 pp. with appendices.
- Goff, G.P. and J.Lien. 1988. Atlantic leatherback turtle, *Dermochelys coriacea*, in cold water off Newfoundland and Labrador. *Can. Field Nat.* 102(1):1-5.
- Goldenberg, S.B., C.W. Landsea, A.M. Mestas-Nunez, W.M. Gray. 2001. The recent increase in Atlantic hurricane activity: causes and implications. *Science* 293:474-479
- Gottfried, P.K., and J.A. Osborne. 1982. Distribution, abundance and size of *Corbicula manilensis* (Philippi) in a spring-fed central Florida stream. *Florida Scientist* 45(3):178-188.
- Graff, D. 1995. Nesting and hunting survey of the turtles of the island of São Tomé. Progress Report July 1995, ECOFAC Componente de São Tomé e Príncipe, 33 pp.
- Greene CH, Pershing AJ, Cronin TM and Ceci N. 2008. Arctic climate change and its impacts on the ecology of the North Atlantic. *Ecology* 89:S24-S38.
- Greene, K. 2002. Beach Nourishment: A Review of the Biological and Physical Impacts. Atlantic States Marine Fisheries Commission (ASMFC) Habitat Management Series #7. 179 pp.
- Greene, R.J. Jr. 1987. Characteristics of oil industry dredge and drilling sounds in the Beaufort Sea. *Journal of Acoustical Society of America* 82: 1315-1324.
- Grunwald, C., J. Stabile, J.R. Waldman, R. Gross, and I. Wirgin. 2002. Population genetics of shortnose sturgeon (*Acipenser brevirostrum*) based on mitochondrial DNA control region sequences. *Molecular Ecology* 11: 000-000.
- Guerra-Garcia, J.M. and J. C. Garcia-Gomez. 2006. Recolonization of defaunated sediments: Fine versus gross sand and dredging versus experimental trays. *Estuarine Coastal and Shelf Science* 68 (1-2): 328-342
- Guilbard, F., J. Munro, P. Dumont, D. Hatin, and R. Fortin. 2007. Feeding ecology of Atlantic sturgeon and Lake sturgeon co-occurring in the St. Lawrence Estuarine Transition Zone. *American Fisheries Society Symposium*. 56: 85-104.

Haley, N. 1996. Juvenile sturgeon use in the Hudson River Estuary. Master's thesis. University of Massachusetts, Amherst, MA, USA.

Hamann, M., C.J. Limpus, and M.A. Read. 2007. Chapter 15 Vulnerability of marine reptiles in the Great Barrier Reef to climate change. In: Johnson JE, Marshall PA (eds) Climate change and the Great Barrier Reef: a vulnerability assessment, Great Barrier Reef Marine Park Authority and Australia Greenhouse Office, Hobart, p 465–496.

Hansen, P.D. 1985. Chlorinated hydrocarbons and hatching success in Baltic herring spring spawners. *Marine Environmental Research* 15:59-76.

Hatase, H., M. Kinoshita, T. Bando, N. Kamezaki, K. Sato, Y. Matsuzawa, K. Goto, K. Omuta, Y. Nakashima, H. Takeshita, and W. Sakamoto. 2002. Population structure of loggerhead turtles, *Caretta caretta*, nesting in Japan: Bottlenecks on the Pacific population. *Marine Biology* 141:299-305.

Hatin, D., R. Fortin, and F. Caron. 2002. Movements and aggregation areas of adult Atlantic sturgeon (*Acipenser oxyrinchus*) in the St. Lawrence River estuary, Québec, Canada. *Journal of Applied Ichthyology* 18: 586-594.

Hatin, D., Lachance, S., D. Fournier. 2007a. Effect of Dredged Sediment Deposition on use by Atlantic Sturgeon and Lake Sturgeon at an Open-water Disposal Site in the St. Lawrence Estuarine Transition Zone. *American Fisheries Society Symposium* 56:235-255.

Hatin, D., J. Munro, F. Caron, and R. D. Simons. 2007. Movements, home range size, and habitat use and selection of early juvenile Atlantic sturgeon in the St. Lawrence estuarine transition zone. Pp. 129-155 in J. Munro, D. Hatin, J.E. Hightower, K. McKown, K.L. Sulak, A.W. Kahnle, and F. Caron (eds.) *Anadromous sturgeon: habitat, threats, and management*. American Fisheries Society Symposium 56, Bethesda, MD 215 pp.

Hawkes, L. A. Broderick, M. Godfrey and B. Godley. 2005. Status of nesting loggerhead turtles, *Caretta caretta*, at Bald Head Island (North Carolina, USA) after 24 years of intensive monitoring and conservation. *Oryx*. 39(1): 65-72.

Hawkes, L.A., A.C. Broderick, M.H. Godfrey, and B.J. Godley. 2007. Investigating the potential impacts of climate change on a marine turtle population. *Global Change Biology* 13: 1-10.

Hawkes, L.A., A.C. Broderick, M.H. Godfrey, and B.J. Godley. 2009. Climate change and marine turtles. *Endangered Species Research* 7:137-154.

Hawkes, L.A., A.C. Broderick, M.S. Coyne, M.H. Godfrey, L.-F. Lopez-Jurado, P. Lopez-Suarez, S.E. Merino, N. Varo-Cruz, and B.J. Godley. 2006. Phenotypically linked dichotomy in sea turtle foraging requires multiple conservation approaches. *Current Biology* 16: 990-995.

Hays, G.C., A.C. Broderick, F. Glen, B.J. Godley, J.D.R. Houghton, and J.D. Metcalfe. 2002. Water temperature and interesting intervals for loggerhead (*Caretta caretta*) and green (*Chelonia mydas*) sea turtles. *Journal of Thermal Biology* 27: 429-432.

- Heppell, S.S., D.T. Crouse, L.B. Crowder, S.P. Epperly, W. Gabriel, T. Henwood, R. Marquez, and N.B. Thompson. 2005. A population model to estimate recovery time, population size, and management impacts on Kemp's ridley sea turtles. *Chelonian Conservation and Biology* 4(4):767-773.
- Hildebrand, H. 1982. A historical review of the status of sea turtle populations in the western Gulf of Mexico, P. 447-453. In K.A. Bjorndal (ed.), *Biology and conservation of sea turtles*. Smithsonian Institution Press, Washington, D.C.
- Hilterman, M.L. and E. Goverse. 2004. Annual report of the 2003 leatherback turtle research and monitoring project in Suriname. World Wildlife Fund - Guianas Forests and Environmental Conservation Project (WWF-GFECF) Technical Report of the Netherlands Committee for IUCN (NC-IUCN), Amsterdam, the Netherlands, 21p.
- Hirth, H.F. 1971. Synopsis of biological data on the green sea turtle, *Chelonia mydas*. FAO Fisheries Synopsis No. 85: 1-77.
- Hirth, H.F. 1997. Synopsis of the biological data of the green turtle, *Chelonia mydas* (Linnaeus 1758). USFWS Biological Report 97(1): 1-120.
- Holland, B.F., Jr. and G.F. Yelverton. 1973. Distribution and biological studies of anadromous fishes offshore North Carolina. North Carolina Department of Natural and Economic Resources, Division of Commercial and Sports Fisheries, Morehead City. Special Scientific Report 24:1-132.
- Hoover, J.J., Boysen, K.A., Beard, J.A., and H. Smith. 2011. Assessing the risk of entrainment by cutterhead dredges to juvenile lake sturgeon (*Acipenser fulvescens*) and juvenile pallid sturgeon (*Scaphirhynchus albus*). *Journal of Applied Ichthyology* 27:369-375.
- Hoover, J.J., Killgore, K.J., Clarke, D.G., Smith, H., Turnage, A., and Beard, J. 2005. Paddlefish and sturgeon entrainment by dredges: Swimming performance as an indicator of risk. DOER Technical Notes Collection (ERDC-TN-DOER-E22), U.S. Army Engineer Research and Development Center, Vicksburg, MS.
- Hulin, V., and J.M. Guillon. 2007. Female philopatry in a heterogenous environment: ordinary conditions leading to extraordinary ESS sex ratios. *BMC Evolutionary Biology* 7:13
- Hulme, P.E. 2005. Adapting to climate change: is there scope for ecological management in the face of global threat? *Journal of Applied Ecology* 43: 617-627. IPCC (Intergovernmental Panel on Climate Change) 2007. Fourth Assessment Report. Valencia, Spain.
- Innis, C., C. Merigo, K. Dodge, M. Tlusty, M. Dodge, B. Sharp, A. Myers, A. McIntosh, D. Wunn, C. Perkins, T.H. Herdt, T. Norton, and M. Lutcavage. 2010. Health Evaluation of Leatherback Turtles (*Dermochelys coriacea*) in the Northwestern Atlantic During Direct Capture and Fisheries Gear Disentanglement. *Chelonian Conservation and Biology*, 9(2):205-222.
- Intergovernmental Panel on Climate Change (IPCC). 2007a. Climate Change 2007 – Impacts, Adaptation and Vulnerability. Contribution of Working Group II to the Fourth Assessment Report of the IPCC. IPCC, Geneva.

Intergovernmental Panel on Climate Change (IPCC). 2007b. Climate Change 2007 - The Physical Science Basis. Contribution of Working Group I to the Fourth Assessment Report of the IPCC. IPCC, Geneva.

Intergovernmental Panel on Climate Change. 2007. Summary for Policymakers. In Solomon, S., D. Qin, M. Manning, Z. Chen, M. Marquis, K.B. Averyt, M. Tignor and H.L. Miller (editors). Climate Change 2007: The Physical Science Basis. Contribution of Working Group I to the Fourth Assessment Report of the Intergovernmental Panel on Climate Change. Cambridge University Press, Cambridge, United Kingdom, and New York, New York, USA.

James, M.C., C.A. Ottensmeyer, and R.A. Myers. 2005b. Identification of high-use habitat and threats to leatherback sea turtles in northern waters: new directions for conservation. *Ecol. Lett.* 8: 195-201.

James, M.C., R.A. Myers, and C.A. Ottenmeyer. 2005a. Behaviour of leatherback sea turtles, *Dermodochelys coriacea*, during the migratory cycle. *Proc. R. Soc. B*, 272: 1547-1555.

Jenkins, W.E., T.I.J. Smith, L.D. Heyward, and D.M. Knott. 1993. Tolerance of shortnose sturgeon, *Acipenser brevirostrum*, juveniles to different salinity and dissolved oxygen concentrations. Proceedings of the Southeast Association of Fish and Wildlife Agencies, Atlanta, Georgia.

Johnson, and P.J. Eliazar (Compilers) Proceedings of the Fourteenth Annual Symposium on Sea Turtle Biology and Conservation. NOAA Technical Memorandum NMFS-SEFSC-351, 323 pp.

Johnson, J. H., D. S. Dropkin, B. E. Warkentine, J. W. Rachlin, and W. D. Andrews. 1997. Food habits of Atlantic sturgeon off the central New Jersey coast. *Transactions of the American Fisheries Society* 126: 166-170.

Johnson, M. P. & P.L. Tyack. 2003. A digital acoustic recording tag for measuring the response of wild marine mammals to sound. *IEEE J. Oceanic Engng* 28: 3–12.

Johnston Jr., S.A. 1981. Estuarine Dredge and Fill Activities: A Review of Impacts. *Environmental Management* 5(5): 427-440.

Jones A.R., W. Gladstone, N.J. Hacking. 2007. Australian sandy beach ecosystems and climate change: ecology and management. *Aust Zool* 34:190–202

Kahnle, A.W., K.A. Hattala, K.A. McKown. 2007. Status of Atlantic sturgeon of the Hudson River Estuary, New York, USA. *American Fisheries Society Symposium*. 56:347-363.

Kasperek, M., B.J. Godley, and A.C. Broderick. 2001. Nesting of the green turtle, *Chelonia mydas*, in the Mediterranean: a review of status and conservation needs. *Zoology in the Middle East* 24: 45-74.

Keevin, Thomas M. and Hempen, G. L. 1997. The Environmental Effects of Underwater Explosions with Methods to Mitigate Impacts. U. S. Army Corps of Engineers, St. Louis District.

- Kreeger, D., J. Adkins, P. Cole, R. Najjar, D. Velinsky, P. Conolly, and J. Kraeuter. May 2010. Climate Change and the Delaware Estuary: Three Case Studies in Vulnerability Assessment and Adaptation Planning. Partnership for the Delaware Estuary, PDE Report No. 10-01. 1 –117 pp.
- Kelle, L., N. Gratiot, I. Nolibos, J. Therese, R. Wongsopawiro, and B. DeThois. 2007. Monitoring of nesting leatherback turtles (*Dermodochelys coriacea*): contribution of remote-sensing for real time assessment of beach coverage in French Guiana. *Chelonian Conserv Biol* 6: 142–149.
- Ketten, D.R. and S.M. Bartol. (2005). Functional Measures of Sea Turtle Hearing. ONR Award No: N00014-02-1-0510.
- Kieffer and Kynard in review [book to be published by AFS]. Kieffer, M. C., and B. Kynard. In review. Pre-spawning and non-spawning spring migrations, spawning, and effects of hydroelectric dam operation and river regulation on spawning of Connecticut River shortnose sturgeon.
- Kieffer, M.C. and B. Kynard. 1993. Annual movements of shortnose and Atlantic sturgeons in the Merrimack River, Massachusetts. *Transactions of the American Fisheries Society* 122: 1088-1103.
- Kocan, R.M., M.B. Matta, and S. Salazar. 1993. A laboratory evaluation of Connecticut River coal tar toxicity to shortnose sturgeon (*Acipenser brevirostrum*) embryos and larvae. Final Report to the National Oceanic and Atmospheric Administration, Seattle, Washington.
- Kuller, Z. 1999. Current status and conservation of marine turtles on the Mediterranean coast of Israel. *Marine Turtle Newsletter* 86: 3-5.
- Kynard, B. and M. Horgan. 2002. Ontogenetic behavior and migration of Atlantic sturgeon, *Acipenser oxyrinchus oxyrinchus*, and shortnose sturgeon, *A. brevirostrum*, with notes on social behavior. *Environmental Behavior of Fishes* 63: 137-150.
- LaCasella, E.L., P.H. Dutton, and S.P. Epperly. 2005. Genetic stock composition of loggerheads (*Caretta caretta*) encountered in the Atlantic northeast distant (NED) longline fishery using additional mtDNA analysis. Pages 302-303 in Frick M., A. Panagopoulou, A.F. Rees, and K. Williams (compilers). *Book of Abstracts of the Twenty-sixth Annual Symposium on Sea Turtle Biology and Conservation*. International Sea Turtle Society, Athens, Greece.
- Lageux, C.J., C. Campbell, L.H. Herbst, A.R. Knowlton and B. Weigle. 1998. Demography of marine turtles harvested by Miskitu Indians of Atlantic Nicaragua. U.S. Department of Commerce, NOAA Technical Memorandum NMFS-SEFSC-412: 90.
- Lalli, C.M. and T.R. Parsons. 1997. *Biological oceanography: An introduction – 2nd Edition*. Pages 1-13. Butterworth-Heinemann Publications. 335 pp.
- Laney, R.W., J.E. Hightower, B.R. Versak, M.F. Mangold, W.W. Cole Jr., and S.E. Winslow. 2007. Distribution, habitat use, and size of Atlantic sturgeon captured during cooperative winter tagging cruises, 1988–2006. Pages 167-182. In: J. Munro, D. Hatin, J. E. Hightower, K. McKown, K. J. Sulak, A. W. Kahnle, and F. Caron, (editors), *Anadromous sturgeons: habits, threats, and management*. Am. Fish. Soc. Symp. 56, Bethesda, MD.
- Larson, K. and Moehl, C. 1990. “Fish entrainment by dredges in Grays Harbor, Washington”. *Effects of dredging on anadromous Pacific Coast fishes*. C.A. Simenstad ed., Washington Sea

Grant Program, University of Washington, Seattle. 102-12 pp.

LaSalle, M.W. 1990. Physical and chemical alterations associated with dredging. C.A. Simenstad editor. Proceedings of the workshop on the effects of dredging on anadromous Pacific coast fishes. Washington Sea Grant Program, Seattle. 1-12 pp.

Laurent, L., J. Lescure, L. Excoffier, B. Bowen, M. Domingo, M. Hadjichristophorou, L. Kornaraki, and G. Trabuchet. 1993. Genetic studies of relationships between Mediterranean and Atlantic populations of loggerhead turtle *Caretta caretta* with a mitochondrial marker. *Comptes Rendus de l'Academie des Sciences (Paris), Sciences de la Vie/Life Sciences* 316:1233-1239.

Laurent, L., P. Casale, M.N. Bradai, B.J. Godley, G. Gerosa, A.C. Broderick, W. Schroth, B. Schierwater, A.M. Levy, D. Freggi, E.M. Abd El-Mawla, D.A. Hadoud, H.E. Gomati, M. Domingo, M. Hadjichristophorou, L. Kornaraki, F. Demirayak, and C. Gautier. 1998. Molecular resolution of the marine turtle stock composition in fishery bycatch: A case study in the Mediterranean. *Molecular Ecology* 7: 1529-1542.

Leland, J. G., III. 1968. A survey of the sturgeon fishery of South Carolina. Bears Bluff Labs. No. 47, 27 pp.

Lewison, R.L., L.B. Crowder, and D.J. Shaver. 2003. The impact of turtle excluder devices and fisheries closures on loggerhead and Kemp's ridley strandings in the western Gulf of Mexico. *Conservation Biology* 17(4): 1089-1097.

Lewison, R.L., S.A. Freeman, and L.B. Crowder. 2004. Quantifying the effects of fisheries on threatened species: the impact of pelagic longlines on loggerhead and leatherback sea turtles. *Ecology Letters*. 7: 221-231.

Limpus, C.J. and D.J. Limpus. 2000. Mangroves in the diet of *Chelonia mydas* in Queensland, Australia. *Mar Turtle Newsl* 89: 13-15.

Limpus, C.J. and D.J. Limpus. 2003. Loggerhead turtles in the equatorial Pacific and southern Pacific Ocean: A species in decline. In: Bolten, A.B., and B.E. Witherington (eds.), *Loggerhead Sea Turtles*. Smithsonian Institution.

Longwell, A.C., S. Chang, A. Hebert, J. Hughes and D. Perry. 1992. Pollution and developmental abnormalities of Atlantic fishes. *Environmental Biology of Fishes* 35:1- 21.

Lutcavage, M.E. and P. Plotkin, B. Witherington, and P.L. Lutz. 1997. Human impacts on sea turtle survival, p.387-409. In P.L. Lutz and J.A. Musick, (eds.), *The Biology of Sea Turtles*, CRC Press, Boca Raton, Florida. 432pp.

Lutcavage, M.E. and P.L. Lutz. 1997. Diving Physiology. Pp. 277-296 in *The Biology of Sea Turtles*. P.L. Lutz and J.A. Musick (Eds). CRC Press.

Mac, M.J., and C.C. Edsall. 1991. Environmental contaminants and the reproductive success of lake trout in the Great Lakes: An epidemiological approach. *Journal of Toxicology and Environmental Health* 33:375-394.

- MacLeod, C.D. 2009. Global climate change, range changes and potential implications for the conservation of marine cetaceans: a review and synthesis. *Endang Species Res* 7: 125-136.
- Magnuson, J.J., J.A. Bjorndal, W.D. DuPaul, G.L. Graham, D.W. Owens, C.H. Peterson, P.C.H. Prichard, J.I. Richardson, G.E. Saul, and C.W. West. 1990. *Decline of Sea Turtles: Causes and Prevention*. Committee on Sea Turtle Conservation, Board of Environmental Studies and Toxicology, Board on Biology, Commission of Life Sciences, National Research Council, National Academy Press, Washington, D.C. 259 pp.
- Maier, P. P., A. L. Segars, M. D. Arendt, J. D. Whitaker, B. W. Stender, L. Parker, R. Vendetti, D. W. Owens, J. Quattro, and S. R. Murphy. 2004. Development of an index of sea turtle abundance based on in-water sampling with trawl gear. Final report to the National Marine Fisheries Service. 86 pp.
- Mangin, E. 1964. Croissance en Longueur de Trois Esturgeons d'Amerique du Nord: *Acipenser oxyrhynchus*, Mitchill, *Acipenser fulvescens*, Rafinesque, et *Acipenser brevirostris* LeSueur. *Verh. Int. Ver. Limnology* 15: 968-974.
- Mansfield, K. L. 2006. Sources of mortality, movements, and behavior of sea turtles in Virginia. Chapter 5. Sea turtle population estimates in Virginia. pp.193-240. Ph.D. dissertation. School of Marine Science, College of William and Mary.
- Mansfield, K.L., V.S. Saba, J.A. Keinath, and J.A. Musick. 2009. Satellite tracking reveals a dichotomy in migration strategies among juvenile loggerhead turtles in the Northwest Atlantic. *Marine Biology* 156:2555–2570.
- Marcano, L.A. and J.J. Alio-M. 2000. Incidental capture of sea turtles by the industrial shrimping fleet off northwestern Venezuela. U.S. department of Commerce, NOAA Technical Memorandum NMFS-SEFSC-436:107.
- Marcano, L.A. and J.J. Alio-M. 2000. Incidental capture of sea turtles by the industrial shrimping fleet off northwestern Venezuela. U.S. department of Commerce, NOAA Technical Memorandum NMFS-SEFSC-436:107.
- Margaritoulis, D., R. Argano, I. Baran, F. Bentivegna, M.N. Bradai, J.A. Camiñas, P. Casale, G. De Metrio, A. Demetropoulos, G. Gerosa, B.J. Godley, D.A. Haddoud, J. Houghton, L. Laurent, and B. Lazar. 2003. Loggerhead turtles in the Mediterranean Sea: Present knowledge and conservation perspectives. Pages 175-198. In: A.B. Bolten and B.E. Witherington (eds.) *Loggerhead Sea Turtles*. Smithsonian Books, Washington, D.C. 319 pp.
- Márquez, M.R., A. Villanueva O., and M. Sánchez P. 1982. The population of the Kemp's ridley sea turtle in the Gulf of Mexico – *Lepidochelys kempii*. In: K.A. Bjorndal (editor), *Biology and Conservation of Sea Turtles*. Washington, D.C. Smithsonian Institute Press. p. 159-164.
- Márquez, R. 1990. *FAO Species Catalogue, Vol. 11. Sea turtles of the world, an annotated and illustrated catalogue of sea turtle species known to date*. FAO Fisheries Synopsis, 125. 81pp.
- Martin, R.E. 1996. Storm impacts on loggerhead turtle reproductive success. *Mar Turtle News* 73:10–12.

- Mayfield RB, Cech JJ Jr. 2004. Temperature effects on green sturgeon bioenergetics. *Trans Am Fish Soc* 133:961–970
- Mazaris A.D., G. Mastinos, J.D. Pantis. 2009. Evaluating the impacts of coastal squeeze on sea turtle nesting. *Ocean Coast Manag* 52:139–145.
- McCauley, J.E., Parr, R.A. and D. R. Hancock. 1977. Benthic Infauna and Maintenance Dredging: A Case Study. *Water Research* 11: 233-242.
- McClellan, C.M., and A.J. Read. 2007. Complexity and variation in loggerhead sea turtle life history. *Biology Letters* 3: 592-594.
- McCord, J.W., M.R. Collins, W.C. Post, and T.J. Smith. 2007. Attempts to develop an index of abundance for age-1 Atlantic sturgeon in South Carolina, USA. *Am. Fisheries Society Symposium* 56: 397-403.
- McEnroe, M., and J.J. Cech. 1987. Osmoregulation in white sturgeon: life history aspects. *American Fisheries Society Symposium* 1:191-196.
- McMahon, C.R., and G.C. Hays. 2006. Thermal niche, large-scale movements and implications of climate change for a critically endangered marine vertebrate. *Global Change Biology* 12:1330-1338.
- Meylan, A. 1982. Estimation of population size in sea turtles. In: K.A. Bjorndal (ed.) *Biology and Conservation of Sea Turtles*. Smithsonian Inst. Press, Wash. D.C. p 135-138.
- Meylan, A., B. Schroeder, and A. Mosier. 1995. Sea turtle nesting activity in the state of Florida. *Fla. Mar. Res. Publ.* 52: 1-51.
- Meylan, A., B.E. Witherington, B. Brost, R. Rivero, and P.S. Kubilis. 2006. Sea turtle nesting in Florida, USA: Assessments of abundance and trends for regionally significant populations of *Caretta*, *Chelonia*, and *Dermochelys*. pp 306-307. In: M. Frick, A. Panagopoulou, A. Rees, and K. Williams (compilers). *26th Annual Symposium on Sea Turtle Biology and Conservation Book of Abstracts*.
- Mitchell, G.H., R.D. Kenney, A.M. Farak, and R.J. Campbell. 2003. Evaluation of occurrence of endangered and threatened marine species in naval ship trial areas and transit lanes in the Gulf of Maine and offshore of Georges Bank. *NUWC-NPT Technical Memo 02-121A*. March 2003. 113 pp.
- Mohler, J. W. 2003. Culture manual for the Atlantic sturgeon, *Acipenser oxyrinchus oxyrinchus*. U.S. Fish and Wildlife Service, Hadley, Massachusetts. 70 pp.
- Monzón-Argüello, C., A. Marco., C. Rico, C. Carreras, P. Calabuig, and L.F. López-Jurado. 2006. Transatlantic migration of juvenile loggerhead turtles (*Caretta caretta*): magnetic latitudinal influence. Page 106 in Frick M., A. Panagopoulou, A.F. Rees, and K. Williams (compilers). *Book of Abstracts of the Twenty-sixth Annual Symposium on Sea Turtle Biology and Conservation*. International Sea Turtle Society, Athens, Greece.

- Morgan, R.P., V.J. Rasin and L.A. Noe. 1973. Effects of Suspended Sediments on the Development of Eggs and Larvae of Striped Bass and White Perch. Natural resources Institute, Chesapeake Biological Laboratory, U of Maryland, Center for Environmental and Estuarine Studies. 20 pp.
- Morreale, S.J. and E.A. Standora. 1990. Occurrence, movement, and behavior of the Kemp's ridley and other sea turtles in New York waters. Annual report for the NYSDEC, Return A Gift To Wildlife Program, April 1989 - April 1990.
- Morreale, S.J. and E.A. Standora. 1998. Early life stage ecology of sea turtles in northeastern U.S. waters. U.S. Dep. Commer. NOAA Tech. Mem. NOAA Fisheries-SEFSC-413, 49 pp.
- Morreale, S.J., and E.A. Standora. 1993. Occurrence, movement, and behavior of the Kemp's ridley and other sea turtles in New York waters. Okeanos Ocean Research Foundation Final Report April 1988-March 1993. 70 pp.
- Morreale, S.J., C.F. Smith, K. Durham, R.A. DiGiovanni, Jr., and A.A. Aguirre. 2005. Assessing health, status, and trends in northeastern sea turtle populations. Interim report - Sept. 2002 - Nov. 2004. Gloucester, Massachusetts: National Marine Fisheries Service.
- Moser, M.L. and S.W. Ross. 1995. Habitat use and movements of shortnose and Atlantic sturgeons in the lower Cape Fear River, North Carolina. Transactions of the American Fisheries Society 124:225-234.
- Moser, Mary. 1999. Cape Fear River Blast Mitigation Tests: Results of Caged Fish Necropsies, Final Report to CZR, Inc. under Contract to US Army Corps of Engineers, Wilmington District.
- Mrosovsky, N. 1981. Plastic jellyfish. Marine Turtle Newsletter 17: 5-6.
- Mrosovsky, N., G.D. Ryan, M.C. James. 2009. Leatherback turtles: The menace of plastic. Marine Pollution Bulletin 58: 287-289.
- Munro, J. 2007. Anadromous sturgeons: Habitats, threats, and management - synthesis and summary. Am. Fisheries Society Symposium 56: 1-15.
- Murawski, S.A. and A.L. Pacheco. 1977. Biological and fisheries data on Atlantic sturgeon, *Acipenser oxyrinchus* (Mitchill). National Marine Fisheries Service Technical Series Report 10: 1-69.
- Murdoch, P. S., J. S. Baron, and T. L. Miller. 2000. Potential effects of climate change on surface-water quality in North America. JAWRA Journal of the American Water Resources Association, 36: 347-366.
- Murphy, T.M. and S.R. Hopkins. 1984. Aerial and ground surveys of marine turtle nesting beaches in the southeast region. United States Final Report to NMFS-SEFSC. 73pp.
- Murphy, T.M., S.R. Murphy, D.B. Griffin, and C. P. Hope. 2006. Recent occurrence, spatial distribution and temporal variability of leatherback turtles (*Dermochelys coriacea*) in nearshore waters of South Carolina, USA. Chel. Cons. Biol. 5(2): 216-224.

- Murray, K.T. 2004. Bycatch of sea turtles in the Mid-Atlantic sea scallop (*Placopecten magellanicus*) dredge fishery during 2003. NEFSC Reference Document 04-11; 25 pp.
- Murray, K.T. 2006. Estimated average annual bycatch of loggerhead sea turtles (*Caretta caretta*) in U.S. Mid-Atlantic bottom otter trawl gear, 1996-2004. NEFSC Reference Document 06-19; 26 pp.
- Murray, K.T. 2007. Estimated bycatch of loggerhead sea turtles (*Caretta caretta*) in U.S. Mid-Atlantic scallop trawl gear, 2004-2005, and in sea scallop dredge gear, 2005. NEFSC Reference Document 07-04; 30 pp.
- Murray, K.T. 2008. Estimated average annual bycatch of loggerhead sea turtles (*Caretta caretta*) in U.S. Mid-Atlantic bottom otter trawl gear, 1996-2004 (2nd edition). NEFSC Reference Document 08-20; 32 pp.
- Murray, K.T. 2009a. Characteristics and magnitude of sea turtle bycatch in US mid-Atlantic gillnet gear. *Endangered Species Research* 8:211-224.
- Murray, K.T. 2009b. Proration of estimated bycatch of loggerhead sea turtles in U.S. Mid-Atlantic sink gillnet gear to vessel trip report landed catch, 2002-2006. NEFSC Reference Document 09-19; 7 pp.
- Murray, K.T. 2011. Sea turtle bycatch in the U.S. sea scallop (*Placopecten magellanicus*) dredge fishery, 2001–2008. *Fish Res.* 107:137-146.
- Musick, and J. Wyneken (editors). *The Biology of Sea Turtles Vol. II*, CRC Press, Boca Raton, Florida. p. 339-353.
- Musick, J.A. and C.J. Limpus. 1997. Habitat utilization and migration in juvenile sea turtles. Pp. 137-164 In: Lutz, P.L., and J.A. Musick, eds., *The Biology of Sea Turtles*. CRC Press, New York. 432 pp.
- NAST (National Assessment Synthesis Team). 2000. *Climate Change Impacts on the United States: The Potential Consequences of Climate Variability and Change*, US Global Change Research Program, Washington DC, 2000.
- NAST (National Assessment Synthesis Team). 2008. *Climate Change Impacts on the United States: The Potential Consequences of Climate Variability and Change*, US Global Change Research Program, Washington DC, 2000
<http://www.usgcrp.gov/usgcrp/Library/nationalassessment/1IntroA.pdf>
- National Research Council (NRC). 1990. *Decline of the Sea Turtles: Causes and Prevention*. Committee on Sea Turtle Conservation. Natl. Academy Press, Washington, D.C. 259 pp.
- Nicholls, R.J. 1998. Coastal vulnerability assessment for sea level rise: evaluation and selection of methodologies for implementation. Technical Report R098002, Caribbean Planning for Adaption to Global Climate Change (CPACC) Project. Available at: www.cpacc.org.
- Niklitschek, J. E. 2001. Bioenergetics modeling and assessment of suitable habitat for juvenile Atlantic and shortnose sturgeons (*Acipenser oxyrinchus* and *A. brevirostrum*) in the Chesapeake Bay. Dissertation. University of Maryland at College Park, College Park.

NMFS (National Marine Fisheries Service) and USFWS (U.S. Fish and Wildlife Service). 1991. Recovery plan for U.S. population of Atlantic green turtle *Chelonia mydas*. Washington, D.C.: National Marine Fisheries Service. 58 pp.

NMFS (National Marine Fisheries Service) and USFWS (U.S. Fish and Wildlife Service). 1992. Recovery plan for leatherback turtles *Dermochelys coriacea* in the U.S. Caribbean, Atlantic, and Gulf of Mexico. Washington, D.C.: National Marine Fisheries Service. 65 pp.

NMFS (National Marine Fisheries Service) and USFWS (U.S. Fish and Wildlife Service). 1995. Status reviews for sea turtles listed under the Endangered Species Act of 1973. Silver Spring, Maryland: National Marine Fisheries Service. 139 pp.

NMFS (National Marine Fisheries Service) and USFWS (U.S. Fish and Wildlife Service). 1998a. Recovery Plan for U.S. Pacific Populations of the Leatherback Turtle (*Dermochelys coriacea*). Silver Spring, Maryland: National Marine Fisheries Service. 65 pp.

NMFS (National Marine Fisheries Service) and USFWS (U.S. Fish and Wildlife Service). 1998b. Recovery Plan for U.S. Pacific Populations of the Green Turtle (*Chelonia mydas*). Silver Spring, Maryland: National Marine Fisheries Service. 84 pp.

NMFS (National Marine Fisheries Service) and USFWS (U.S. Fish and Wildlife Service). 2007a. Loggerhead sea turtle (*Caretta caretta*) 5 year review: summary and evaluation. National Marine Fisheries Service, Silver Spring, Maryland. 65 pp.

NMFS (National Marine Fisheries Service) and USFWS (U.S. Fish and Wildlife Service). 2007b. Leatherback sea turtle (*Dermochelys coriacea*) 5 year review: summary and evaluation. Silver Spring, Maryland: National Marine Fisheries Service. 79 pp.

NMFS (National Marine Fisheries Service) and USFWS (U.S. Fish and Wildlife Service). 2007c. Kemp's ridley sea turtle (*Lepidochelys kempii*) 5 year review: summary and evaluation. Silver Spring, Maryland: National Marine Fisheries Service. 50 pp.

NMFS (National Marine Fisheries Service) and USFWS (U.S. Fish and Wildlife Service). 2007d. Green sea turtle (*Chelonia mydas*) 5 year review: summary and evaluation. Silver Spring, Maryland: National Marine Fisheries Service. 102 pp.

NMFS (National Marine Fisheries Service) and USFWS (U.S. Fish and Wildlife Service). 2008. Recovery plan for the Northwest Atlantic population of the loggerhead turtle (*Caretta caretta*), Second revision. Washington, D.C.: National Marine Fisheries Service. 325 pp.

NMFS (National Marine Fisheries Service) NEFSC (Northeast Fisheries Science Center). 2011. Preliminary summer 2010 regional abundance estimate of loggerhead turtles (*Caretta caretta*) in northwestern Atlantic Ocean continental shelf waters. US Dept Commerce, Northeast Fisheries Science Center Reference Document 11-03; 33 pp.

NMFS (National Marine Fisheries Service), USFWS (U.S. Fish and Wildlife Service), and SEMARNAT. 2011. Bi-National Recovery Plan for the Kemp's Ridley Sea Turtle (*Lepidochelys kempii*), Second Revision. National Marine Fisheries Service. Silver Spring, Maryland 156 pp. + appendices.

NMFS (National Marine Fisheries Service). 2002. Endangered Species Act Section 7 Consultation on Shrimp Trawling in the Southeastern United States, under the Sea Turtle Conservation Regulations and as Managed by the Fishery Management Plans for Shrimp in the South Atlantic and Gulf of Mexico. Biological Opinion. December 2, 2002.

NMFS (National Marine Fisheries Service). 2004. Endangered Species Act Section 7 Consultation on the Proposed Regulatory Amendments to the Fisheries Management Plan for the Pelagic Fisheries of the Western Pacific. Biological Opinion. February 23, 2004.

NMFS (National Marine Fisheries Service). 2004. Endangered Species Act Section 7 Reinitiated Consultation on the Continued Authorization of the Atlantic Pelagic Longline Fishery under the Fishery Management Plan for Atlantic Tunas, Swordfish, and Sharks (HMS FMP). Biological Opinion. June 1, 2004.

NMFS (National Marine Fisheries Service). 2006. Endangered Species Act Section 7 Consultation on the Proposed Renewal of an Operating License for the Oyster Creek Nuclear Generating Station, Barnegat Bay, New Jersey. Biological Opinion. November 22, 2006.

NMFS (National Marine Fisheries Service). 2008b. Summary Report of the Workshop on Interactions Between Sea Turtles and Vertical Lines in Fixed-Gear Fisheries. M.L. Schwartz (ed.), Rhode Island Sea Grant, Narragansett, Rhode Island. 54 pp.

NMFS (National Marine Fisheries Service). 2011. Biennial Report to Congress on the Recovery Program for Threatened and Endangered Species, October 1, 2008 – September 30, 2010. Washington, D.C.: National Marine Fisheries Service. 194 pp.

NMFS (National Marine Fisheries Service). 2012. Reinitiation of Endangered Species Act (ESA) Section 7 Consultation on the Continued Implementation of the Sea Turtle Conservation Regulations, as Proposed to Be Amended, and the Continued Authorization of the Southeast U.S. Shrimp Fisheries in Federal Waters under the Magnuson-Stevens Act. Biological Opinion. May 8, 2012.

NMFS and USFWS. 1992. Recovery plan for leatherback turtles in the U.S. Caribbean, Atlantic, and Gulf of Mexico. National Marine Fisheries Service, Washington, D.C. 65 pp.

NMFS and USFWS. 1995. Status reviews for sea turtles listed under the Endangered Species Act of 1973. National Marine Fisheries Service, Silver Spring, Maryland. 139 pp.

NMFS and USFWS. 1998b. Recovery Plan for the U.S. Pacific Population of the Leatherback Turtle (*Dermochelys coriacea*). National Marine Fisheries Service, Silver Spring, Maryland.

NMFS and USFWS. 2007b. Leatherback sea turtle (*Dermochelys coriacea*) 5 year review: summary and evaluation. National Marine Fisheries Service, Silver Spring, Maryland. 79 pp.

NMFS SEFSC (Southeast Fisheries Science Center). 2009. An assessment of loggerhead sea turtles to estimate impacts of mortality reductions on population dynamics. NMFS SEFSC Contribution PRD-08/09-14. 45 pp.

NMFS Southeast Fisheries Science Center. 2001. Stock assessments of loggerheads and leatherback sea turtles and an assessment of the impact of the pelagic longline fishery on the

loggerhead and leatherback sea turtles of the Western North Atlantic. U.S. Department of Commerce, National Marine Fisheries Service, Miami, FL, SEFSC Contribution PRD-00/01-08; Parts I-III and Appendices I-IV. NOAA Tech. Memo NMFS-SEFSC-455, 343 pp.

NMFS. 1998. Recovery plan for the shortnose sturgeon (*Acipenser brevirostrum*). Prepared by the Shortnose Sturgeon Recovery Team for the National Marine Fisheries Service, Silver Spring, Maryland 104 pp.

NRC (National Research Council). 1990. *Decline of the Sea Turtles: Causes and Prevention*. Washington, D.C.: National Academy Press. 259 pp.

NYHS (New York Historical Society as cited by Dovel as Mitchell. S. 1811). 1809. Volume 1. Collections of the New-York Historical Society for the year 1809.

NYSDEC (New York State Department of Environmental Conservation). 2003. "Final Environmental Impact Statement Concerning the Applications to Renew New York State Pollutant Discharge Elimination System (SPDES) Permits for the Roseton 1 and 2 Bowline 1 and 2 and IP2 and IP3 2 and 3 Steam Electric Generating Stations, Orange, Rockland and Westchester Counties" (Hudson River Power Plants FEIS). June 25, 2003.

O'Herron, J.C. and R.W. Hastings. 1985. A Study of the Shortnose Sturgeon (*Acipenser brevirostrum*) population in the upper tidal Delaware River: Assessment of impacts of maintenance dredging (Post-dredging study of Duck Island and Perriwig ranges), Draft final report. Prepared for the U.S. Army Corps of Engineers, Philadelphia District by the Center for Coastal and Environmental Studies, Rutgers, the State University of New Jersey, New Brunswick, NJ.

Palka, D. 2000. Abundance and distribution of sea turtles estimated from data collected during cetacean surveys. In: Bjorndal, K.A. and A.B. Bolten. Proceedings of a workshop on assessing abundance and trends for in-water sea turtle populations. U.S. Dep. Commer. NOAA Tech. Mem. NMFS-SEFSC-445, 83pp.

Palmer M.A., C.A. Reidy, C. Nilsson, M. Florke, J. Alcamo, P.S. Lake, and N. Bond. 2008. Climate change and the world's river basins: anticipating management options. *Frontiers in Ecology and the Environment* 6:81-89.

Parnesan, C., and G. Yohe. 2003. A globally coherent fingerprint of climate change impacts across natural systems. *Nature* 421:37-42.

Pearce, A.F. 2001. Contrasting population structure of the loggerhead turtle (*Caretta caretta*) using mitochondrial and nuclear DNA markers. Master's thesis, University of Florida.

Pearce, A.F. and B.W. Bowen. 2001. Final report: Identification of loggerhead (*Caretta caretta*) stock structure in the southeastern United States and adjacent regions using nuclear DNA markers. Project number T-99-SEC-04. Submitted to the National Marine Fisheries Service, May 7, 2001. 79 pp.

Pike, D.A. and J.C. Stiner. 2007. Sea turtle species vary in their susceptibility to tropical cyclones. *Oecologia* 153: 471-478.

- Pike, D.A., R.L. Antworth, and J.C. Stiner. 2006. Earlier nesting contributes to shorter nesting seasons for the loggerhead sea turtle, *Caretta caretta*. *Journal of Herpetology* 40(1): 91-94.
- Pikitch, E.K., P. Doukakis, L. Lauck, P. Chakrabarty, and D.L. Erickson. 2005. Status, trends and management of sturgeon and paddlefish fisheries. *Fish and Fisheries* 6: 233–265.
- Pisces Conservation Ltd. 2008. The status of fish populations and ecology of the Hudson River. Prepared by R.M. Seaby and P.A. Henderson. <http://www.riverkeeper.org/wp-content/uploads/2009/06/Status-of-Fish-in-the-Hudson-Pisces.pdf>
- Plaziat, J.C., and P.G.E.F. Augustinius. 2004. Evolution of progradation/ erosion along the French Guiana mangrove coast: a comparison of mapped shorelines since the 18th century with Holocene data. *Mar Geol* 208: 127–143.
- Polis, D.F., S.L. Kupferman, and K. Szekiolda. 1973. Physical oceanography. Delaware Bay Report Series, Vol. 4. University of Delaware, Newark, DE.
- Pritchard, P.C.H. 1982. Nesting of the leatherback turtle, *Dermochelys coriacea*, in Pacific, Mexico, with a new estimate of the world population status. *Copeia* 1982: 741-747.
- Pritchard, P.C.H. 2002. Global status of sea turtles: An overview. Document INF-001 prepared for the Inter-American Convention for the Protection and Conservation of Sea Turtles, First Conference of the Parties (COP1IAC), First part August 6-8, 2002.
- Prusty, G., S. Dash, and M.P. Singh. 2007. Spatio-temporal analysis of multi-date IRS imageries for turtle habitat dynamics characterisation at Gahirmatha coast, India. *Int J Remote Sens* 28: 871–883
- Rahmstorf, S. 1997. Risk of sea-change in the Atlantic. *Nature* 388: 825–826.
- Rahmstorf, S. 1999. Shifting seas in the greenhouse? *Nature* 399: 523–524.
- Rankin-Baransky, K., C.J. Williams, A.L. Bass, B.W. Bowen, and J.R. Spotila. 2001. Origin of loggerhead turtles stranded in the northeastern United States as determined by mitochondrial DNA analysis. *Journal of Herpetology* 35(4):638-646.
- Rebel, T.P. 1974. Sea turtles and the turtle industry of the West Indies, Florida and the Gulf of Mexico. Univ. Miami Press, Coral Gables, Florida.
- Rees, A.F., A. Saad, and M. Jony. 2005. Marine turtle nesting survey, Syria 2004: discovery of a “major” green turtle nesting area. Page 38 in Book of Abstracts of the Second Mediterranean Conference on Marine Turtles. Antalya, Turkey, 4-7 May 2005.
- Reine, K., and Clarke, D. 1998. Entrainment by hydraulic dredges—A review of potential impacts. Technical Note DOER-E1. U.S. Army Engineer Research and Development Center, Vicksburg, MS.
- Revelles, M., C. Carreras, L. Cardona, A. Marco, F. Bentivegna, J.J. Castillo, G. de Martino, J.L. Mons, M.B. Smith, C. Rico, M. Pascual, and A. Aguilar. 2007. Evidence for an asymmetrical size

exchange of loggerhead sea turtles between the Mediterranean and the Atlantic through the Straits of Gibraltar. *Journal of Experimental Marine Biology and Ecology* 349:261-271.

Rhoads, D.C. and J.D. Germano. 1982. Characterization of Benthic Processes Using Sediment Profile Imaging: an Efficient Method of Remote Ecological Monitoring on the Seafloor (REMOTS System). *Marine Ecology Progress Series* 8:115-128

Richardson A.J., A. Bakun, G.C. Hays, and M.J. Gibbons. 2009. The jellyfish joyride: causes, consequences and management responses to a more gelatinous future. *Trends in Ecology and Evolution* 24:312-322.

Ridgway, S.H., E.G. Weaver, J.G. McCormick, J. Palin, and J.H. Anderson. 1969. Hearing in the Giant Sea Turtle, *Chelonia mydas*. *Proceedings of the National Academy of Sciences* 64(3): 884-890.

Rivalan, P., P.H. Dutton, E. Baudry, S.E. Roden, and M. Girondot. 2005. Demographic scenario inferred from genetic data in leatherback turtles nesting in French Guiana and Suriname. *Biol Conserv* 1: 1–9.

Robinson, M.M., H.J. Dowsett, and M.A. Chandler. 2008. Pliocene role in assessing future climate impacts. *Eos, Transactions of the American Geophysical Union* 89(49):501-502.

Rochard, E., M. Lepage, and L. Meauzé. Identification et caractérisation de l'aire de répartition marine de l'esturgeon européen *Acipenser sturio* a partir de déclarations de captures. 1997. *Aquat. Living. Resour.* 10: 101-109.

Rogers, S.G., and W. Weber. 1995b. Status and restoration of Atlantic and shortnose sturgeons in Georgia. Final Report to the National Marine Fisheries Service, Southeast Regional Office, St. Petersburg, Florida.

Rosenthal, H. and D. F. Alderdice. 1976. Sublethal effects of environmental stressors, natural and pollutional, on marine fish eggs and larvae. *Journal of the Fisheries Research Board of Canada* 33: 2047-2065.

Ross, J.P. 1996. Caution urged in the interpretation of trends at nesting beaches. *Marine Turtle Newsletter* 74: 9-10.

Ross, J.P. 2005. Hurricane effects on nesting *Caretta caretta*. *Mar Turtle Newsl* 108:13–14.

Ruben, H.J., and S.J. Morreale. 1999. Draft Biological Assessment for Sea Turtles in New York and New Jersey Harbor Complex. Unpublished Biological Assessment submitted to National Marine Fisheries Service.

Ruelle, R. and C. Henry. 1992. Organochlorine compounds in pallid sturgeon. *Contaminant*

Ruelle, R. and C. Henry. 1994. Life history observations and contaminant evaluation of pallid sturgeon. Final Report U.S. Fish and Wildlife Service, Fish and Wildlife Enhancement, South Dakota Field Office, 420 South Garfield Avenue, Suite 400, Pierre, South Dakota 57501-5408.

Ruelle, R., and K.D. Keenlyne. 1993. Contaminants in Missouri River pallid sturgeon. *Bull. Environ. Contam. Toxicol.* 50: 898-906.

Sarti Martinez, L., A.R. Barragan, D.G. Munoz, N. Garcia, P. Huerta, and F. Vargas. 2007. Conservation and biology of the leatherback turtle in the Mexican Pacific. *Chelonian Conservation and Biology* 6(1): 70-78.

Sarti, L., S. Eckert, P. Dutton, A. Barragán, and N. García. 2000. The current situation of the leatherback population on the Pacific coast of Mexico and central America, abundance and distribution of the nestings: an update. Pages 85-87 In: H. Kalb and T. Wibbels, compilers. *Proceedings of the Nineteenth Annual Symposium on Sea Turtle Conservation and Biology*. NOAA Technical Memorandum NMFS-SEFSC-443.

Sarti, L., S.A. Eckert, N. Garcia, and A.R. Barragan. 1996. Decline of the world's largest nesting assemblage of leatherback turtles. *Marine Turtle Newsletter* 74: 2-5.

Savoy, T. 2007. Prey eaten by Atlantic sturgeon in Connecticut waters. *Am. Fisheries Society Symposium* 56: 157-165.

Savoy, T., and D. Pacileo. 2003. Movements and important habitats of subadult Atlantic sturgeon in Connecticut waters. *Transactions of the American Fisheries Society*. 132: 1-8.

Schmid, J.R., and W.N. Witzell. 1997. Age and growth of wild Kemp's ridley turtles (*Lepidochelys kempi*): cumulative results of tagging studies in Florida. *Chelonian Conservation and Biology* 2(4): 532-537.

Schubel, J.R., H.H. Carter, R.E. Wilson, W.M. Wise, M.G. Heaton, and M.G. Gross. 1978. Field investigations of the nature, degree, and extent of turbidity generated by open-water pipeline disposal operations. Technical Report D-78-30; U.S. Army Engineer Waterways Experiment Station, Vicksburg, Miss., 245 pp.

Schueller, P. and D.L. Peterson. 2006. Population status and spawning movements of Atlantic sturgeon in the Altamaha River, Georgia. Presentation to the 14th American Fisheries Society Southern Division Meeting, San Antonio, February 8-12th, 2006.

Schultz, J.P. 1975. Sea turtles nesting in Surinam. *Zoologische Verhandelingen (Leiden)*, Number 143: 172 pp.

Scott, W. B., and M. C. Scott. 1988. Atlantic fishes of Canada. *Canadian Bulletin of Fisheries and Aquatic Science* No. 219. pp. 68-71.

Scott, W.B. and E.J. Crossman. 1973. Freshwater fishes of Canada. *Fisheries Research Board of Canada. Bulletin* 184. pp. 80-82.

Seaturtle.org. Sea turtle tracking database. Available at <http://www.seaturtle.org>.

Secor, D. H. 2002. Atlantic sturgeon fisheries and stock abundances during the late nineteenth century. Pages 89-98 In: W. Van Winkle, P. J. Anders, D. H. Secor, and D. A. Dixon, (editors), *Biology, management, and protection of North American sturgeon*. American Fisheries Society Symposium 28, Bethesda, Maryland.

Secor, D.H. and J.R. Waldman. 1999. Historical abundance of Delaware Bay Atlantic sturgeon and potential rate of recovery. *American Fisheries Society Symposium* 23: 203-

Secor, D.J. and E.J. Niklitschek. 2002. Sensitivity of sturgeons to environmental hypoxia: A review of physiological and ecological evidence, p. 61-78 In: R.V. Thurston (Ed.) *Fish Physiology, Toxicology, and Water Quality. Proceedings of the Sixth International Symposium, La Paz, MX, 22-26 Jan. 2001.* U.S. Environmental Protection Agency Office of Research and Development, Ecosystems Research Division, Athens, GA. EPA/600/R-02/097. 372 pp.

Sella, I. 1982. Sea turtles in the Eastern Mediterranean and Northern Red Sea. Pages 417-423 in K.A. Bjorndal, ed. *Biology and Conservation of Sea Turtles.* Washington, D.C.: Smithsonian Institution Press.

Seminoff, J.A. 2004. *Chelonia mydas.* In 2007 IUCN Red List of Threatened Species. Accessed 31 July 2009. <http://www.iucnredlist.org/search/details.php/4615/summ>.

Shamblin, B.M. 2007. Population structure of loggerhead sea turtles (*Caretta caretta*) nesting in the southeastern United States inferred from mitochondrial DNA sequences and microsatellite loci. Master's thesis, University of Georgia. 59 pp.

Sherk, J.A. J.M. O'Connor and D.A. Neumann. 1975. Effects of suspended and deposited sediments on estuarine environments. In: *Estuarine Research Vol. II. Geology and Engineering.* L.E. Cronin (editor). New York: Academic Press, Inc.

Sherk, J.A. 1972. Current Status of the Knowledge of the Biological Effects of Suspended and Deposited Sediments in Chesapeake Bay. *Chesapeake Science*, vol. 13, Supplement: Biota of the Chesapeake Bay pp. S137-S144.

Sherk, J.A. 1971. Effects of suspended and deposited sediments on estuarine organisms. Chesapeake Biological Laboratory, University of Maryland. Contribution No. 443.

Shirey, C., C. C. Martin, and E. D. Stetzar. 1999. Atlantic sturgeon abundance and movement in the lower Delaware River. DE Division of Fish and Wildlife, Dover, DE, USA. Final Report to the National Marine Fisheries Service, Northeast Region, State, Federal & Constituent Programs Office. Project No. AFC-9, Grant No. NA86FA0315. 34 pp.

Shoop, C.R. 1987. *The Sea Turtles.* Pages 357-358 in R.H. Backus and D.W. Bourne, eds. Georges Bank. Cambridge, Massachusetts: MIT Press.

Shoop, C.R. and R.D. Kenney. 1992. Seasonal distributions and abundances of loggerhead and leatherback sea turtles in waters of the northeastern United States. *Herpetological Monographs* 6: 43-67.

Short, F.T. and H.A. Neckles. 1999. The effects of global climate change on seagrasses. *Aquat Bot* 63: 169-196.

Simpson, P.C. 2008. Movements and habitat use of Delaware River Atlantic sturgeon. Master Thesis, Delaware State University, Dover, DE 128 p.

Skjeveland, Jorgen E., Stuart A. Welsh, Michael F. Mangold, Sheila M. Eyler, and Seaberry Nachbar. 2000. A Report of Investigations and Research on Atlantic and Shortnose Sturgeon in Maryland Waters of the Chesapeake bay (1996-2000). U.S. Fish and Wildlife Service, Annapolis, MD. 44 pp.

Slay, C.K. and J.I. Richardson. 1988. King's Bay, Georgia: Dredging and Turtles. Schroeder, B.A. (compiler). Proceedings of the eighth annual conference on sea turtle biology and conservation. NOAA Technical Memorandum NMFS-SEFC-214, pp. 109-111.

Smith, Hugh M. and Barton A. Bean. 1899. List of fishes known to inhabit the waters of the District of Columbia and vicinity. Prepared for the United States Fish Commission. Washington Government Printing Office, Washington, D.C.

Smith, T. I. J., D. E. Marchette, and G. F. Ulrich. 1984. The Atlantic sturgeon fishery in South

Smith, T. I. J., E. K. Dingley, and D. E. Marchette. 1980. Induced spawning and culture of Atlantic sturgeon. *Progressive Fish-Culturist* 42: 147-151.

Smith, T.I.J. 1985. The fishery, biology, and management of Atlantic sturgeon, *Acipenser oxyrinchus*, in North America. *Environmental Biology of Fishes* 14(1): 61-72.

Smith, T.I.J. and J.P. Clugston. 1997. Status and management of Atlantic sturgeon, *Acipenser oxyrinchus*, in North America. *Environmental Biology of Fishes* 48: 335-346.

Smith, T.I.J., D.E. Marchette and R.A. Smiley. 1982. Life history, ecology, culture and management of Atlantic sturgeon, *Acipenser oxyrinchus oxyrinchus*, Mitchell, in South Carolina. South Carolina Wildlife Marine Resources. Resources Department, Final Report to U.S. Fish and Wildlife Service Project AFS-9. 75 pp.

Snover, M.L., A.A. Hohn, L.B. Crowder, and S.S. Heppell. 2007. Age and growth in Kemp's ridley sea turtles: evidence from mark-recapture and skeletochronology. Pages 89-106 in P.T. Plotkin, ed. *Biology and Conservation of Ridley Sea Turtles*. Baltimore, Maryland: Johns Hopkins University Press.

Snyder, D.E. 1988. Description and identification of shortnose and Atlantic sturgeon larvae. *American Fisheries Society Symposium* 5:7-30.

South Carolina Department of Natural Resources. 2007. Examination of Local Movement and Migratory Behavior of Sea Turtles during spring and summer along the Atlantic coast off the southeastern United States. Unpublished report submitted to NMFS as required by ESA Permit 1540. 45 pp.

Spells, A. 1998. Atlantic sturgeon population evaluation utilizing a fishery dependent reward program in Virginia's major western shore tributaries to the Chesapeake Bay. U.S. Fish and Wildlife Service, Charles City, Virginia.

Spotila, J.R., A.E. Dunham, A.J. Leslie, A.C. Steyermark, P.T. Plotkin and F.V. Paladino. 1996. Worldwide population decline of *Dermochelys coriacea*: are leatherback turtles going extinct? *Chelonian Conservation and Biology* 2: 209-222.

Spotila, J.R., R.D. Reina, A.C. Steyermark, P.T. Plotkin, and F.V. Paladino. 2000. Pacific leatherback turtles face extinction. *Nature* 405(6786):529-530.

Squiers, T. And M. Robillard. 1997. Preliminary report on the location of overwintering sites for shortnose sturgeon in the estuarial complex of the Kennebec River during the winter of 1996/1997. Unpublished report, submitted to the Maine Department of Transportation.

Squiers, T., L. Flagg, and M. Smith. 1982. American shad enhancement and status of sturgeon stocks in selected Maine waters. Completion report, Project AFC-20.

Stein, A.B., K.D. Friedland, and M. Sutherland. 2004. Atlantic sturgeon marine bycatch and mortality on the continental shelf of the Northeast United States. *North American Journal of Fisheries Management* 24: 171-183.

Stephens, S.H., and J. Alvarado-Bremer. 2003. Preliminary information on the effective population size of the Kemp's ridley (*Lepidochelys kempii*) sea turtle. Page 250 In: J.A. Seminoff, compiler. *Proceedings of the Twenty-Second Annual Symposium on Sea Biology and Conservation*. NOAA Technical Memorandum NMFS-SEFSC-503.

Stetzar, E. J. 2002. Population Characterization of Sea Turtles that Seasonally Inhabit the Delaware Estuary. Master of Science thesis, Delaware State University, Dover, Delaware. 136pp.

Stevenson, J. T., and D. H. Secor. 1999. Age determination and growth of Hudson River Atlantic sturgeon, *Acipenser oxyrinchus*. *Fishery Bulletin* 97: 153-166.

Stewart, K., C. Johnson, and M.H. Godfrey. 2007. The minimum size of leatherbacks at reproductive maturity, with a review of sizes for nesting females from the Indian, Atlantic and Pacific Ocean basins. *Herp. Journal* 17:123-128.

Stewart, K., M. Sims, A. Meylan, B. Witherington, B. Brost, and L.B. Crowder. 2011. Leatherback nests increasing significantly in Florida, USA; trends assessed over 30 years using multilevel modeling. *Ecological Applications*, 21(1): 263–273.

Stocker, T.F. and A. Schmittner. 1997. Influence of CO2 emission rates on the stability of the thermohaline circulation. *Nature* 388: 862–865.

Suárez, A. 1999. Preliminary data on sea turtle harvest in the Kai Archipelago, Indonesia. Abstract, 2nd ASEAN Symposium and Workshop on Sea Turtle Biology and Conservation, July 15-17, 1999, Sabah, Malaysia.

Suárez, A., P.H. Dutton, and J. Bakarbessy. 2000. Leatherback (*Dermochelys coriacea*) nesting on the North Vogelkop Coast of Irian Jaya, Indonesia. Page 260 in H.J. Kalb and T. Wibbels, compilers. *Proceedings of the Nineteenth Annual Symposium on Sea Turtle Biology and Conservation*. NOAA Technical Memorandum NMFS-SEFSC-443.

Taub, S.H. 1990. Interstate fishery management plan for Atlantic sturgeon. Fisheries Management Report No. 17. Atlantic States Marine Fisheries Commission, Washington, D.C. 73 pp.

Taubert, B.D. 1980b. Biology of shortnose sturgeon (*Acipenser brevirostrum*) in the Holyoke Pool, Connecticut River, Massachusetts. Ph.D. Thesis, University of Massachusetts, Amherst, 136 p.

Taubert, B.D., and M.J. Dadswell. 1980. Description of some larval shortnose sturgeon (*Acipenser brevirostrum*) from the Holyoke Pool, Connecticut River, Massachusetts, USA, and the Saint John River, New Brunswick, Canada. *Canadian Journal of Zoology* 58:1125-1128.

Taylor, A.C. 1990. The hopper dredge. In: Dickerson, D.D. and D.A. Nelson (Comps.); Proceedings of the National Workshop of Methods to Minimize Dredging Impacts on Sea Turtles, 11-12 May 1988, Jacksonville, Florida. Miscellaneous Paper EL-90-5. Department of the Army, U.S. Army Engineer Waterways Experiment Station, Vicksburg, MS. February, 1990. Pp. 59-63.

Teleki, G.C. and A.J. Chamberlain. 1978. Acute Effects of Underwater Construction Blasting in Fishes in Long Point Bay, Lake Erie. *J. Fish. Res. Board Can.* 35: 1191-1198.

TEWG (Turtle Expert Working Group). 1998. An assessment of the Kemp's ridley (*Lepidochelys kempii*) and loggerhead (*Caretta caretta*) sea turtle populations in the Western North Atlantic. NOAA Technical Memorandum NMFS-SEFSC-409:1-96.

TEWG (Turtle Expert Working Group). 2000. Assessment update for the Kemp's ridley and loggerhead sea turtle populations in the western North Atlantic. NOAA Technical Memorandum NMFS-SEFSC-444:1-115.

TEWG (Turtle Expert Working Group). 2007. An assessment of the leatherback turtle population in the Atlantic Ocean. NOAA Technical Memorandum NMFS-SEFSC-555:1-116.

TEWG (Turtle Expert Working Group). 2009. An assessment of the loggerhead turtle population in the Western North Atlantic Ocean. NOAA Technical Memorandum NMFS-SEFSC-575:1-131.

TEWG. 2000. Assessment update for the Kemp's ridley and loggerhead sea turtle populations in the western North Atlantic. U.S. Dep. Commer. NOAA Tech. Mem. NMFS-SEFSC-444, 115 pp.

TEWG. 2007. An assessment of the leatherback turtle population in the Atlantic Ocean. NOAA Technical Memorandum NMFS-SEFSC-555, 116 pp.

TEWG. 2009. An assessment of the loggerhead turtle population in the Western North Atlantic Ocean. NOAA Technical Memorandum NMFS-SEFSC-575: 1-131.

Titus, J.G. and V.K. Narayanan. 1995. The probability of sea level rise. U.S. Environmental Protection Agency EPA 230-R-95-008. 184 pp.

Turtle Expert Working Group (TEWG). 1998. An assessment of the Kemp's ridley (*Lepidochelys kempii*) and loggerhead (*Caretta caretta*) sea turtle populations in the Western North Atlantic. NOAA Technical Memorandum NOAA Fisheries-SEFSC-409. 96 pp.

Tynan, C.T. and D.P. DeMaster. 1997. Observations and predictions of Arctic climatic change: potential effects on marine mammals. *Arctic* 50: 308-322.

U.S. Army Corps of Engineers (USACE). 2006. Biological Assessment for Research and Compilation of Baseline Data for the Use of Bed-leveling Devices at Port of Palm Beach, Palm Beach County, Florida. Prepared for USACE-Jacksonville District. March.

U.S. Army Corps of Engineers (USACE). 1994. Beach Erosion Control and Hurricane Protection Study, Virginia Beach, Virginia- General Reevaluation Report, Main Report, Environmental Assessment , and Appendices. Norfolk District.

U.S. Army Corps of Engineers (USACE), Norfolk District. 2012. Supplemental Biological Assessment for the Potential Impacts to Atlantic Sturgeon (*Acipenser oxyrinchus oxyrinchus*) Resulting from Beach Nourishment Activities at Sandbridge Beach Utilizing the Sandbridge Shoal Borrow Areas. Submitted to NMFS Northeast Regional Office, April 2012. Norfolk, Virginia. 39 pp.

U.S. Army Corps of Engineers (USACE), Savannah District. 2004. Biological Assessment of Threatened and Endangered Species for Brunswick Harbor Deepening Modification to Allow Use of Bed-leveling Mechanical Dredging, Glynn County, Georgia. July.

U.S. Fish and Wildlife Service (USFWS). 1997. Synopsis of the biological data on the green turtle, *Chelonia mydas* (Linnaeus 1758). Biological Report 97(1). U.S. Fish and Wildlife Service, Washington, D.C. 120 pp.

Uhler, P.R. and O. Lugger. 1876. List of fishes of Maryland. Rept. Comm. Fish. MD. 1876: 67-176.

USACE Environmental Laboratory. Sea Turtle Data Warehouse. Available at <http://el.erdc.usace.army.mil/seaturtles/index.cfm>.

USDO (United States Department of Interior). 1973. Threatened wildlife of the United States. Shortnose sturgeon. Office of Endangered Species and International Activities, Bureau of Sport Fisheries and Wildlife, Washington, D.C. Resource Publication 114 (Revised Resource Publication 34).

USFWS (U.S. Fish and Wildlife Service) and NMFS (National Marine Fisheries Service). 1992. Recovery plan for the Kemp's ridley sea turtle (*Lepidochelys kempi*). Original. St. Petersburg, Florida: National Marine Fisheries Service. 40 pp.

USFWS and NMFS. 1992. Recovery plan for the Kemp's ridley sea turtle (*Lepidochelys kempi*). NMFS, St. Petersburg, Florida. *hatching*. *Curr Biol* 17: R590.

Van Den Avyle, M. J. 1984. Species profile: Life histories and environmental requirements of coastal fishes and invertebrates (South Atlantic): Atlantic sturgeon. U.S. Fish and Wildlife Service Report No. FWS/OBS-82/11.25, and U. S. Army Corps of Engineers Report No. TR EL-82-4, Washington, D.C.

Van Eenennaam, J.P., and S.I. Doroshov. 1998. Effects of age and body size on gonadal development of Atlantic sturgeon. *Journal of Fish Biology* 53: 624-637.

Van Eenennaam, J.P., S.I. Doroshov, G.P. Moberg, J.G. Watson, D.S. Moore and J. Linares. 1996. Reproductive conditions of the Atlantic sturgeon (*Acipenser oxyrinchus*) in the Hudson River. *Estuaries* 19: 769-777.

- Van Houtan, K.S. and J.M. Halley. 2011. Long-Term Climate Forcing in Loggerhead Sea Turtle Nesting. PLoS ONE 6(4): e19043. doi:10.1371/journal.pone.0019043.
- Van Houtan, K.S. and O.L. Bass. 2007. Stormy oceans are associated with declines in sea turtle
- Varanasi, U. 1992. Chemical contaminants and their effects on living marine resources. pp. 59- 71. in: R. H. Stroud (ed.) Stemming the Tide of Coastal Fish Habitat Loss. Proceedings of the Symposium on Conservation of Fish Habitat, Baltimore, Maryland. Marine Recreational Fisheries Number 14. National Coalition for Marine Conservation, Inc., Savannah Georgia.
- Vinyard, L. and W.J. O'Brien. 1976. Effects of light and turbidity on the reactive distance of bluegill (*Lepomis macrochirus*) J. Fish. Res. Board Can. 33: 2845-2849.
- Vladykov, V.D. and J.R. Greeley. 1963. Order Acipenseridae. Pages 24-60 in Fishes of the Western North Atlantic. Memoir Sears Foundation for Marine Research 1(Part III). xxi + 630 pp.
- Von Westernhagen, H., H. Rosenthal, V. Dethlefsen, W. Ernst, U. Harms, and P.D. Hansen. 1981. Bioaccumulating substances and reproductive success in Baltic flounder *Platichthys flesus*. Aquatic Toxicology 1:85-99.
- Waldman JR, Grunwald C, Stabile J, Wirgin I. 2002. Impacts of life history and biogeography on genetic stock structure in Atlantic Sturgeon, *Acipenser oxyrinchus oxyrinchus*, Gulf sturgeon *A. oxyrinchus desotoi*, and shortnose sturgeon, *A. brevirostrum*. J Appl Ichthyol 18:509-518
- Waldman, J.R., J.T. Hart, and I.I. Wirgin. 1996. Stock composition of the New York Bight Atlantic sturgeon fishery based on analysis of mitochondrial DNA. Transactions of the American Fisheries Society 125: 364-371.
- Wallace, B.P., S.S. Heppell, R.L. Lewison, S. Kelez, and L.B. Crowder. 2008. Impacts of fisheries bycatch on loggerhead turtles worldwide inferred from reproductive value analyses. J Appl Ecol 45:1076-1085.
- Walsh, M.G., M.B. Bain, T. Squires, J.R. Walman, and Isaac Wirgin. 2001. Morphological and genetic variation among shortnose sturgeon *Acipenser brevirostrum* from adjacent and distant rivers. Estuaries Vol. 24, No. 1, p. 41-48. February 2001.
- Waluda, C.M., P.G. Rodhouse, G.P. Podesta, P.N. Trathan, and G.J. Pierce. 2001. Surface oceanography of the inferred hatching grounds of *Illex argentinus* (Cephalopoda: Ommastrephidae) and influences on recruitment variability. Marine Biology 139: 671-679.
- Warden, M. and K. Bisack 2010. Analysis of Loggerhead Sea Turtle Bycatch in Mid-Atlantic Bottom Trawl Fisheries to Support the Draft Environmental Impact Statement for Sea Turtle Conservation and Recovery in Relation to Atlantic and Gulf of Mexico Bottom Trawl Fisheries. NOAA NMFS NEFSC Ref. Doc.010. 13 pp.
- Warden, M.L. 2011a. Modeling loggerhead sea turtle (*Caretta caretta*) interactions with US Mid-Atlantic bottom trawl gear for fish and scallops, 2005-2008. Biological Conservation 144:2202-2212.

- Warden, M.L. 2011b. Proration of loggerhead sea turtle (*Caretta caretta*) interactions in U.S. Mid-Atlantic bottom otter trawls for fish and scallops, 2005-2008, by managed species landed. U.S. Department of Commerce, Northeast Fisheries Science Center Reference Document 11-04. 8 p.
- Waters, Thomas F. 1995. Sediment in Streams. American Fisheries Society Monograph 7. American Fisheries Society, Bethesda, MD. Pages 95-96.
- Webster, P.J., G.J. Holland, J.A. Curry, H.R. Chang. 2005. Changes in tropical cyclone number, duration, and intensity in a warming environment. *Science* 309:1844–1846.
- Wehrell, S. 2005. A survey of the groundfish caught by the summer trawl fishery in Minas Basin and Scots Bay. Honours Thesis. Department of Biology, Acadia University, Wolfville, Canada.
- Weishampel, J.F., D.A. Bagley, and L.M. Ehrhart. 2004. Earlier nesting by loggerhead sea turtles following sea surface warming. *Global Change Biology* 10: 1424-1427.
- Welsh, S. A., S. M. Eyler, M. F. Mangold, and A. J. Spells. 2002. Capture locations and growth rates of Atlantic sturgeon in the Chesapeake Bay. Pages 183-194 In: W. Van Winkle, P. J. Anders, D. H. Secor, and D. A. Dixon, (editors), *Biology, management, and protection of North American sturgeon*. American Fisheries Society Symposium 28, Bethesda, Maryland.
- Welsh, Stuart A., Michael F. Mangold, Jorgen E. Skjeveland, and Albert J. Spells. 2002. Distribution and Movement of Shortnose Sturgeon (*Acipenser brevirostrum*) in the Chesapeake Bay. *Estuaries* Vol. 25 No. 1: 101-104.
- Wibbels, T. 2003. Critical approaches to sex determination in sea turtle biology and conservation. In: P. Lutz et al. (editors), *Biology of Sea Turtles*, Vol 2. CRC Press Boca Raton. p. 103-134.
- Wilber, D.H., D.G. Clarke & M.H. Burlas. (2006). Suspended sediment concentrations associated with a beach nourishment project on the northern coast of New Jersey. *Journal of Coastal Research* 22(5): 1035 – 1042.
- Wilber, Dara H. and Douglas C. Clarke. 2001. Biological Effects of Suspended Sediments: A review of suspended sediment impacts on fish and shellfish with relation to dredging activities in estuaries. *North American Journal of Fisheries Woodland*, R. J. 2005. Age, growth, and recruitment of Hudson River shortnose sturgeon (*Acipenser brevirostrum*). Master's thesis. University of Maryland, College Park.
- Wirgin, I. and T.L. King. 2011. Mixed stock analysis of Atlantic sturgeon from coastal locales and a non-spawning river. Presentation of the 2011 Sturgeon Workshop, Alexandria, VA, February 8-10.
- Wirgin, I., Grunwald, C., Carlson, E., Stabile, J., Peterson, D.L. and J. Waldman. 2005. Range-wide population structure of shortnose sturgeon *Acipenser brevirostrum* based on sequence analysis of mitochondrial DNA control region. *Estuaries* 28:406-21.
- Witherington, B., P. Kubilis, B. Brost, and A. Meylan. 2009. Decreasing annual nest counts in a globally important loggerhead sea turtle population. *Ecological Applications* 19: 30-54.

- Witt, M.J., A.C. Broderick, D.J. Johns, C. Martin, R. Penrose, M.S. Hoogmoed, and B.J. Godley. 2007. Prey landscapes help identify potential foraging habitats for leatherback turtles in the NE Atlantic. *Marine Ecology Progress Series* 337: 231-243.
- Witt, M.J., A.C. Broderick, M. Coyne, A. Formia and others. 2008. Satellite tracking highlights difficulties in the design of effective protected areas for critically endangered leatherback turtles *Dermochelys coriacea* during the inter-nesting period. *Oryx* 42: 296–300.
- Witzell, W.N. 2002. Immature Atlantic loggerhead turtles (*Caretta caretta*): suggested changes to the life history model. *Herpetological Review* 33(4): 266-269.
- Witzell, W.N., A.L. Bass, M.J. Bresette, D.A. Singewald, and J.C. Gorham. 2002. Origin of immature loggerhead sea turtles (*Caretta caretta*) at Hutchinson Island, Florida: evidence from mtDNA markers. *Fish. Bull.* 100:624-631.
- Woodland, R.J. and D. H. Secor. 2007. Year-class strength and recovery of endangered shortnose sturgeon in the Hudson River, New York. *Transaction of the American Fisheries Society* 136:72-81.
- Wynne, K. and M. Schwartz. 1999. Guide to marine mammals and turtles of the U.S. Atlantic and Gulf of Mexico. Rhode Island Sea Grant, Narragansett, Rhode Island. 114 pp.
- Young, J. R., T. B. Hoff, W. P. Dey, and J. G. Hoff. 1998. Management recommendations for a Hudson River Atlantic sturgeon fishery based on an age-structured population model. *Fisheries Research in the Hudson River*. State of University of New York Press, Albany, New York. pp. 353.
- Ziegeweid, J.R., C.A. Jennings, and D.L. Peterson. 2008a. Thermal maxima for juvenile shortnose sturgeon acclimated to different temperatures. *Environmental Biology of Fish* 3: 299-307.
- Ziegeweid, J.R., C.A. Jennings, D.L. Peterson and M.C. Black. 2008b. Effects of salinity, temperature, and weight on the survival of young-of-year shortnose sturgeon. *Transactions of the American Fisheries Society* 137:1490-1499.
- Zug, G.R., and J.F. Parham. 1996. Age and growth in leatherback turtles, *Dermochelys coriacea*: a skeletochronological analysis. *Chelonian Conservation and Biology* 2(2): 244-249.
- Zurita, J.C., R. Herrera, A. Arenas, M.E. Torres, C. Calderon, L. Gomez, J.C. Alvarado, and R. Villavicencio. 2003. Nesting loggerhead and green sea turtles in Quintana Roo, Mexico. Pp. 125-127. In: J.A. Seminoff (compiler). *Proceedings of the Twenty-Second Annual Symposium on Sea Turtle Biology and Conservation*. NOAA Tech. Memo. NMFS-SEFSC-503, 308 p.

Appendix A.

Map of Sandbridge Shoal Borrow Area and location along beach where sand will be placed

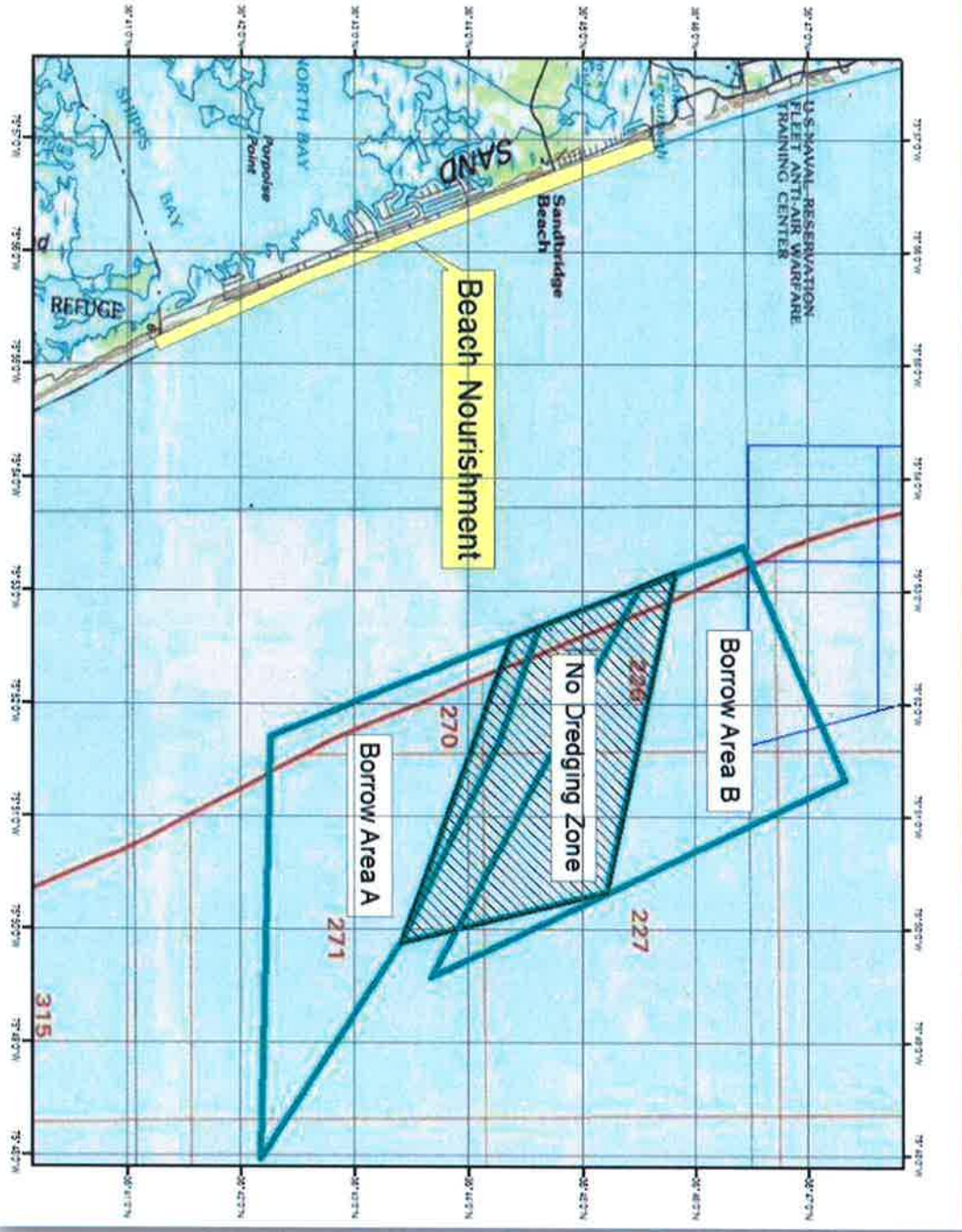

90 DEGREE BED LEVELER CONCEPTUAL DESIGN

LEFT SIDE VIEW

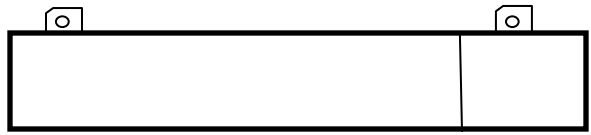

PLAN VIEW

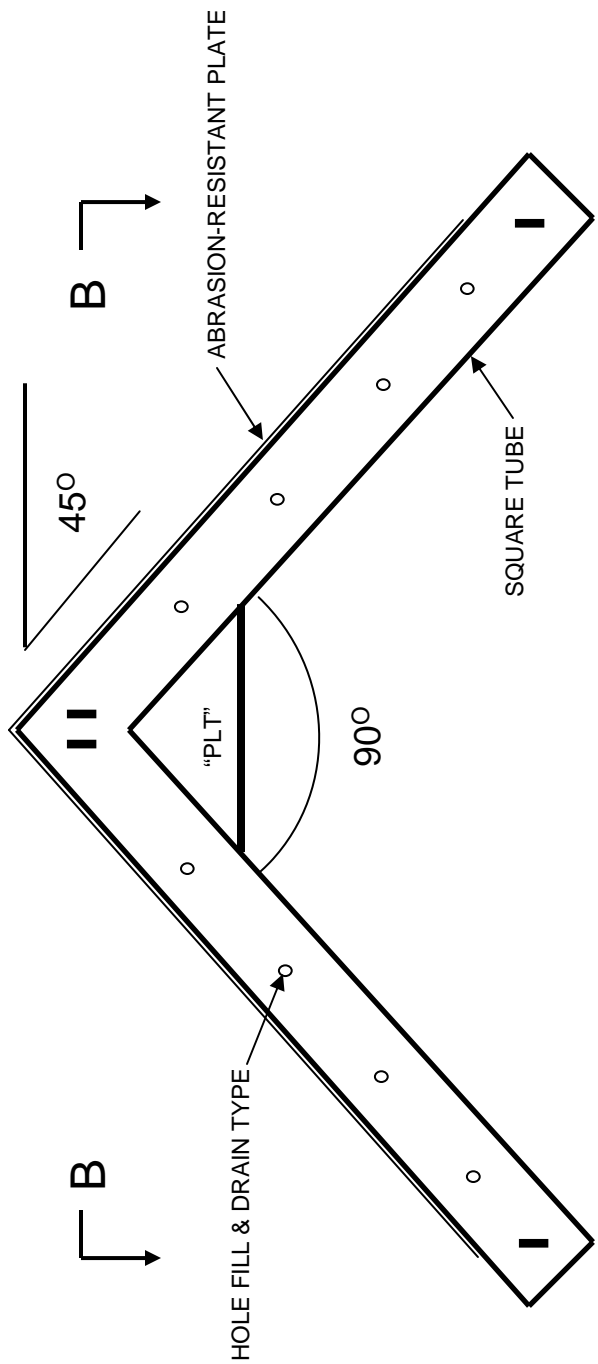

SECTION B - B

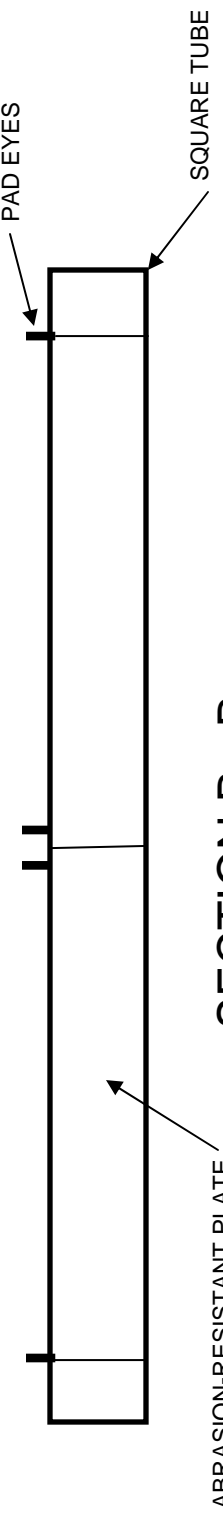

Appendix B
Bed Leveler Information

90 DEGREE BED LEVELER MODEL PHOTOGRAPHS



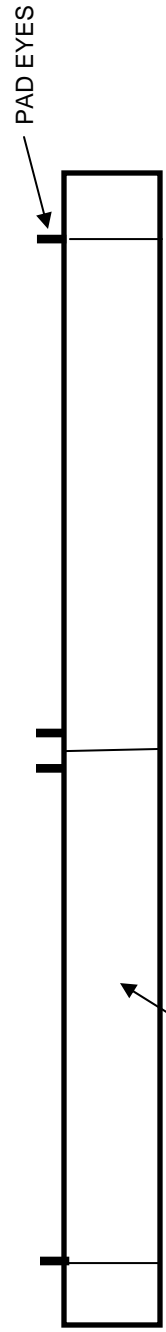

ABRASION-RESISTANT PLATE

SECTION B - B

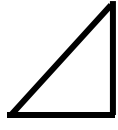

SECTION C-C

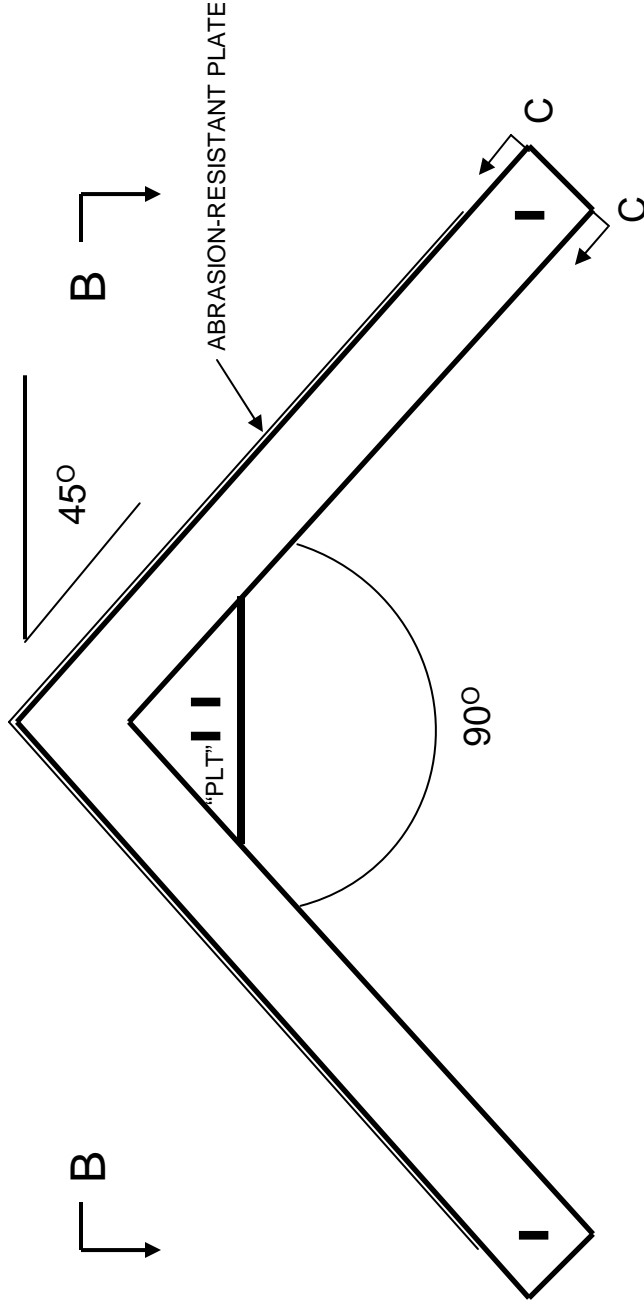

PLAN VIEW

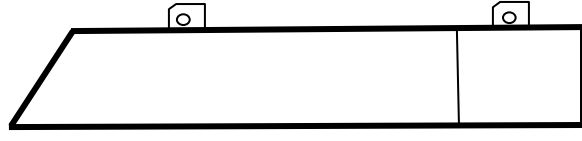

LEFT SIDE VIEW

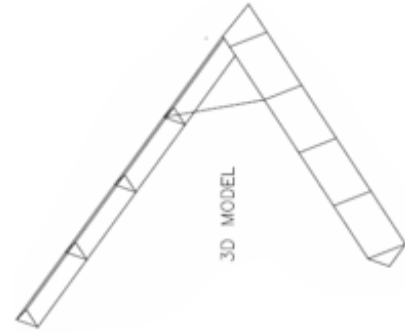

3D MODEL

90 DEGREE RAKED BED LEVELER CONCEPTUAL DESIGN

90 DEGREE RAKED BED LEVELER MODEL PHOTOGRAPHS

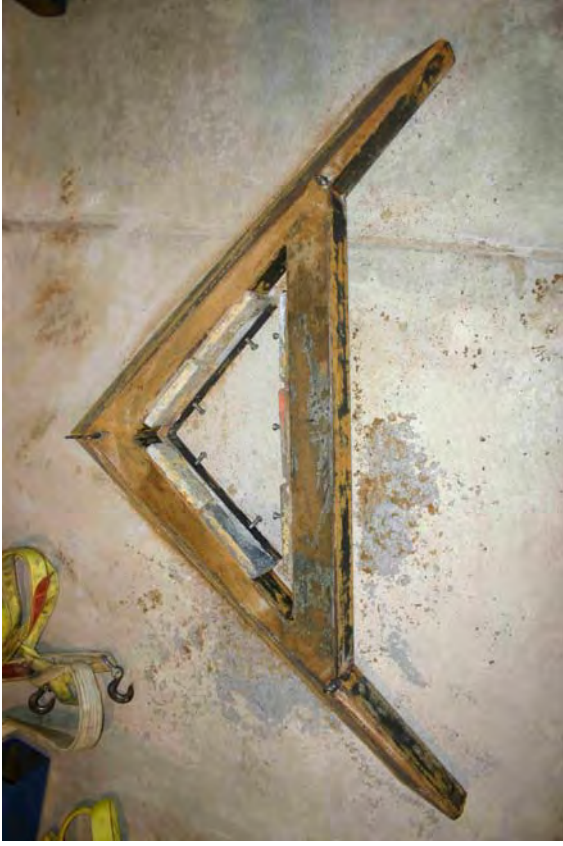

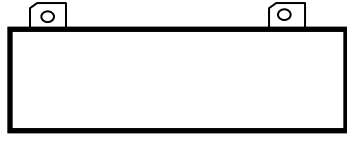
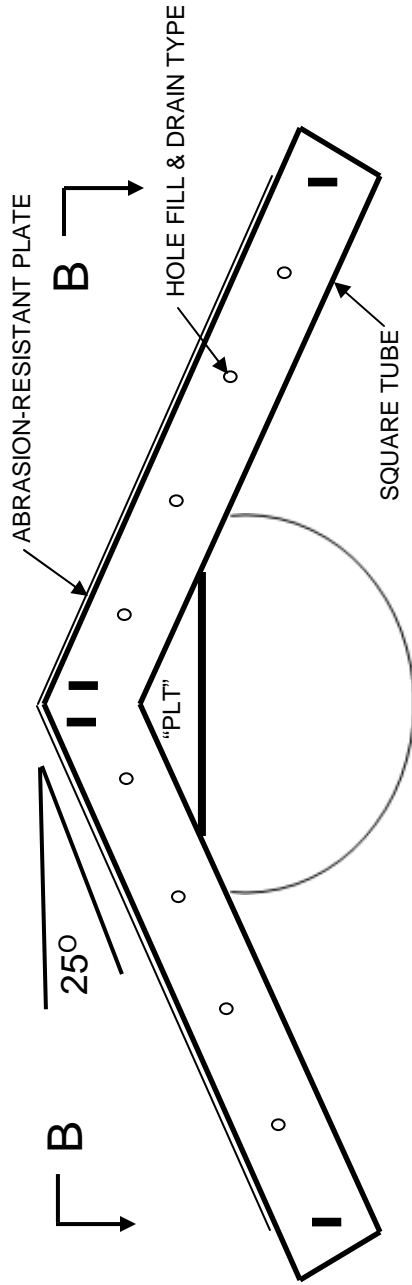
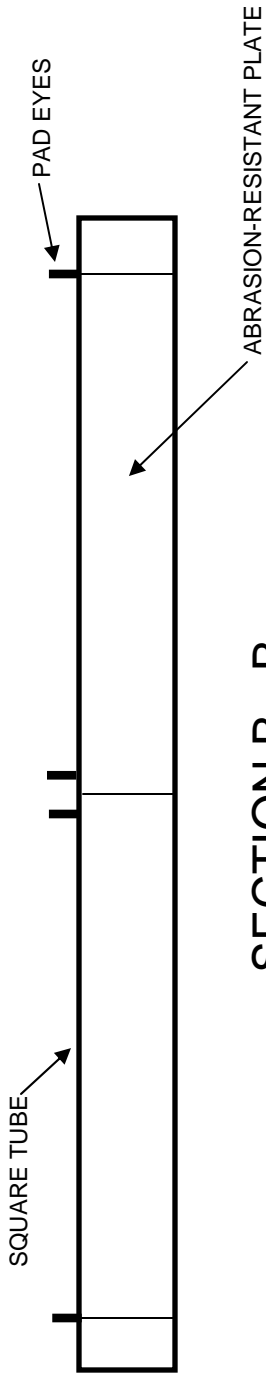

**130 DEGREE BED LEVELER
CONCEPTUAL DESIGN**

130 DEGREE BED LEVELER MODEL PHOTOGRAPHS



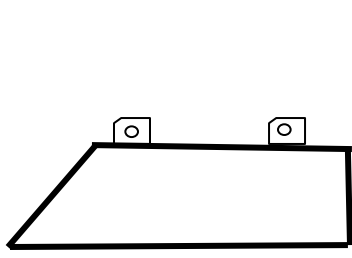
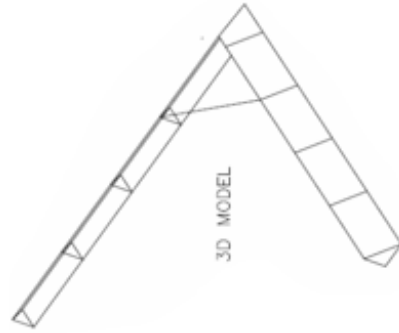
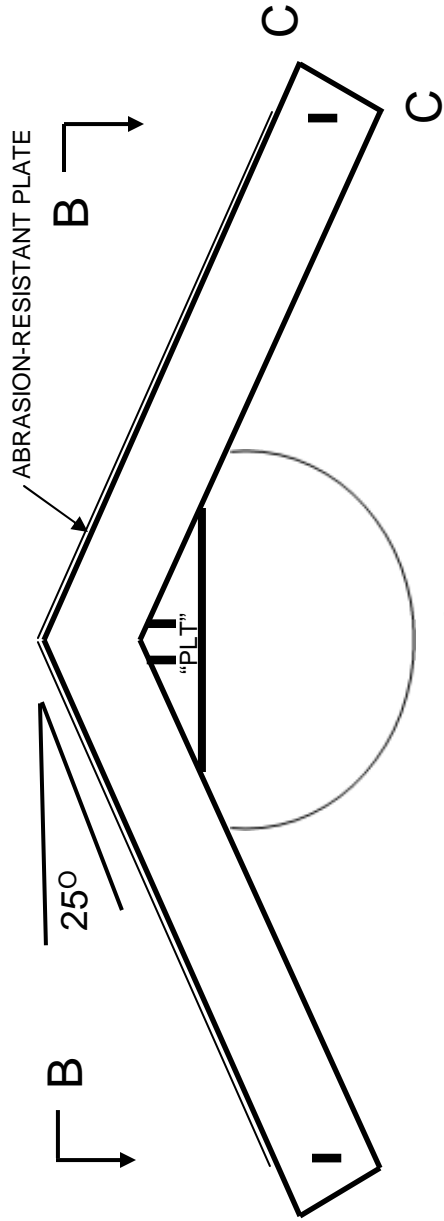
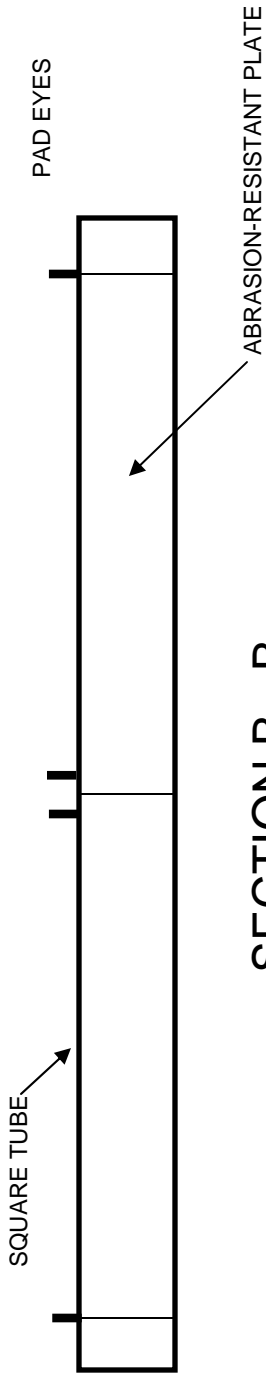
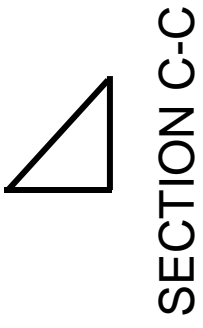

130 DEGREE RAKED BED LEVELER CONCEPTUAL DESIGN

Appendix C.

Historical Take Records of Sturgeon

Sturgeon Take Records from Dredging Operations 1990 - Mar 2012										
Take #	Date	Corps District	Location	Sp	Dredge Type/Name	Status	Specimen Description	Notes	Photos	Documentation
1	30 Oct 90	SAC	Winyah Bay Georgetown	A	H <i>Ouchita</i>	Dead	~69cm, rear half	Overflow Screening	N	Chris Slay pers com Observer report DACW 60-90-C-0067
2	15 Jan 94	SAS	Savannah Harbor	A	H <i>RN Weeks</i>	NA	NA	Found by Turtle observer	No	Steve Calver pers com 14 Jun 05 Observer load sheet and final rpt #DACW21-93-C-0072
3	07 Dec 94	SAS	Savannah Harbor	A	H <i>Dodge Island</i>	Live released	71cm, whole fish	Starboard Skimmer Screening	Yes We have efile	Chris Slay pers com Observer report
4	07 Dec 94 Different Load	SAS	Savannah Harbor	A	H <i>Dodge Island</i>	Dead	77.5cm, whole fish	Starboard Skimmer Screening	Yes We have efile	Chris Slay pers com Observer report
5	Feb 96	NAP	Delaware River Newbold Island	S	P <i>Ozark</i>	Dead	83cm, female w/eggs	In DMA Money Island		NMFS memo for record From Laurie Silva 19 Apr 96
6	Feb 96	NAP	Delaware River Newbold Island	S	P <i>Ozark</i>	Dead	63cm, mature male	In DMA Money Island		NMFS memo for record From Laurie Silva 19 Apr 96
7	06 Jan 98	NAP	Delaware River Kinkora Range	S	P ??	Dead	Either 657mm or 573mm ???	In DMA Money Island	Y Not e-file	Memo for file 20 Jan 98 From Greg Wack NAP
8	12 Jan 98	NAP	Delaware River Florence Range	S	P ??	Dead	Either 657mm or 573mm ???	In DMA Money Island	Y Not e-file	Memo for file 20 Jan 98 From Greg Wack NAP
9	13 Jan 98	NAP	Delaware River Florence Range	S	P ??	Dead	Either 657mm or 573mm ???	In DMA Money Island	Y Not e-file	Memo for file 20 Jan 98 From Greg Wack NAP
10	7 Sep 98	SAW	Wilmington Har Cape Fear River	A	H <i>McFarland</i>	Dead	Head only (1 ft long)	In turtle Inflow screen		Observer incident report Pers com Bill Adams- SAW 26 Jul 04
11	01 Mar 00	SAC	Charleston Harbor	A	H <i>Snyvesant</i>	Dead	Missing head and tail	Main Overflow Screening	No	Chris Slay pers com Observer reporting forms
12	12 Apr 00	SAC	Charleston Harbor	A	H <i>Snyvesant</i>	Dead	71.6cm, whole fish	Starboard Overflow screening	No	Chris Slay pers com Observer reporting forms
13	03 Dec 00	SAW	Wilmington Har MOTSU	A	C <i>New York</i>	Dead	82.5cm, whole fish decomposing	In bucket	Y Not e-file Payonk?	Chris Slay pers com Phil Payonk pers com 30 Jul 04 Bill Adams pers com 28 Jul 04 #DACW54-00-C-0013

Sturgeon Take Records from Dredging Operations 1990 - Mar 2012

Take #	Date	Corps District	Location	Sp	Dredge Type/Name	Status	Specimen Description	Notes	Photos	Documentation
14	24 Feb 01	SAS	Brunswick Harbor	A	H RV Weeks	Dead	Head only	Just mentions take on all forms, no other info.	No	Daily and Weekly Reports, Load sheet.
15	19 Jun 01	NAE	Kennebec River Bath Iron Works	A	C??	Live released		Put in scow, released unharmed		Julie Crocker NMFS pers com 19 Jul 04 2003 Chesapeake BA, Section 7.2 Normandeau Associates, Inc 2001
16	30 Apr 03	NAE	Kennebec River Bath Iron Works	S	C Reed and Reed dredge company	Dead	Fish nearly cut in half		Y We have e-file	Julie Crocker NMFS pers com 19 Jul 04 2003 Chesapeake BA, Section 7.2 Normandeau Associates, Inc 2001
17	6 Oct 03	NAE	Kennebec River Doubling Point	S	H Padre Island	Dead	38.1 inches	In hopper	Y We have e-file	Observer incident report Kennebec River BA Jul 04 Memo for Commander, from Bill Kavanaugh, 1 Jul 04 Bill Kavanaugh pers com 15 Jul 04 Julie Crocker pers com 19 Jul 04
18	6 Oct 03	NAE	Kennebec River Doubling Point	S	H Padre Island	Dead	37.0 inches	In hopper Did not dive Probably died	Y We have e-file	Observer incident report Kennebec River BA Jul 04 Memo for Commander, from Bill Kavanaugh, 1 Jul 04 Bill Kavanaugh pers com 15 Jul 04 Julie Crocker pers com 19 Jul 04
19	6 Oct 03	NAE	Kennebec River Doubling Point	S	H Padre Island	Live	Swam away	In hopper	Y We have e-file	Observer incident report Kennebec River BA Jul 04 Memo for Commander, from Bill Kavanaugh, 1 Jul 04 Bill Kavanaugh pers com 15 Jul 04 Julie Crocker pers com 19 Jul 04

Sturgeon Take Records from Dredging Operations 1990 - Mar 2012

Take #	Date	Corps District	Location	Sp	Dredge Type/ Name	Status	Specimen Description	Notes	Photos	Documentation
20	06 Oct 03	NAE	Kennebec River Doubling Point	S	H <i>Padre Island</i>	Dead	Found alive	In hopper	Y We have e-file	Observer incident report Kennebec River BA Jul 04 Memo for Commander, from Bill Kavanaugh, 1 Jul 04 Bill Kavanaugh pers com 15 Jul 04 Julie Crocker pers com 19 Jul 04
21	08 Oct 03	NAE	Kennebec River Doubling Point	S	H <i>Padre Island</i>	Live	Good condition	In hopper	Y We have e-file	Observer incident report Kennebec River BA Jul 04 Memo for Commander, from Bill Kavanaugh, 1 Jul 04 Bill Kavanaugh pers com 15 Jul 04 Julie Crocker pers com 19 Jul 04
22	07 Jan 04	SAC	Charleston Harbor	A	H <i>Manhattan Island</i>	Live	Whole fish 49 inches total length May have died later when released	Found by Coastwise turtle observers	Yes (We Have e-file)	Robert Chappell pers com 28 Jun 04 Observer daily report 7 Jan 04
23	13 Dec 04	SAM	Gulfport Harbor Channel	G	H <i>Bayport</i>	Dead	Trunk of fish 59.5cm	Found by turtle observers	Yes	Observer incident report Susan Rees pers com 7 Jan 05
24a	28 Dec 04	SAM	Mobile Bar Channel	G	H <i>Padre Island</i>	Dead	Trunk of fish 2 ft, lynch	Found by Turtle observers	Yes (We Have e-file)	Observer incident report Susan Rees pers com 7 Jan 05 #W91278-04-C-0049
24b	01 Jan 05	SAM	Mobile Bar Channel	G	H <i>Padre Island</i>	Dead	Head only of fish 22.5cm	2nd part of take on 28 Dec 04	Yes taken But we Have not received	Observer incident report Susan Rees pers com 7 Jan 05 #W91278-04-C-0049
25	2 Mar 05	SAS	Brunswick Harbor	A	H <i>RN Weeks</i>	Dead	Posterior section only 60 cm section w/tail	Found by turtle observer	Yes (We Have e-file)	Chris Slay pers com 7 Jun 05 Steve Calver pers com 14 Jun 05
26	26 Dec 06	SAS	Brunswick	A	H <i>Newport</i>	Dead	Head only	Caught in port screen and	Black and	Incident and load report

Sturgeon Take Records from Dredging Operations 1990 - Mar 2012

Take #	Date	Corps District	Location	Sp	Dredge Type/ Name	Status	Specimen Description	Notes	Photos	Documentation
								turtle part caught in starboard screen	White	
27	17 Jan 07	SAS	Savannah Entrance Channel	A	H <i>Glenn Edwards</i>	Dead	Whole fish, FL 104 cm	Fresh Dead, 60 Horseshoe crab in with load	Coastwise took photo	Incident and Load report
28	2 Mar 09	SAS	Savannah Entrance Channel	A	H <i>Dodge Island</i>	Dead	Total Length 111 cm	Fresh Dead, found in starboard aft inflow box, load #42		Incident, Load and Daily report
29	6 Feb 10	SAS	Brunswick Entrance Channel	A	H <i>Glenn Edwards</i>	Dead	No measurements	Fore screen contents, Load #19 with 12 Horseshoe crab		No incident report, just listed on load sheet and daily summary
30	7 Feb 10	SAS	Brunswick Entrance Channel	A	H <i>Glenn Edwards</i>	Dead	No measurements	Fore screen contents, Load #25 with 20 Horseshoe crab		No incident report, just listed on load sheet and daily summary
31	2 Feb 10	SAS	Brunswick Entrance Channel	A	H <i>Bayport</i>	Dead	No measurements, head to mid body in load #193 and mid body to tail recovered in load #194.	Stbd screen contents, load #193 and overflow screen in #194.		No incident report, just listed on load sheet and daily summary
32	7 Dec 10	SAW	Wilmington Harbor	A	H <i>Terrapin Island</i>	Dead	Whole fish, FL 61 cm	Fresh Dead, water temp 12 C, air 2 C, load 6	Coastwise took photo	Incident and Load report
33	10 Apr 11	NAO	York Spit Channel	A	H <i>Terrapin Island</i>	Dead	Total Length 24.5" in, Fork Length 13.5", Middle of anus to Anal Fin 3.8"	During Clean up. Torn in half, only posterior from pectoral region to tail, no head. Fins and tail torn but complete		Hopper daily report from, QCR, e-mail, incident report, daily report, load sheets

Sturgeon Take Records from Dredging Operations 1990 - Mar 2012

Take #	Date	Corps District	Location	Sp	Dredge Type/Name	Status	Specimen Description	Notes	Photos	Documentation
34	11 Apr 11	NAO	York Spit Channel	A	H Liberty Island	Dead		During cleanup. Another piece taken on 4/13/11 matches perfectly.	Y	E-mail
35	14 Mar 12	SAC	Charleston Harbor Channel	A	H Glenn Edwards	Dead	Fresh dead, body part 26"-30" Long X 13" width, no head or tail	Load 129 (0024-0345) found in starboard draghead, during cleanup mode. Given to South Carolina DNR	Yes	E-mail, load sheet, incident report
NT	25 May 05	NAO	York Spit Channel	?	H <i>McFarland</i>	Dead	Approx. 2 ft estimate from photos	Too decomposed to identify	Yes (We Have e-file)	Observer final report, REMSA 2004
NDNEF	26 Jun 96	NAN	East Rock Away Long Island	?	H Dodge Island	Dead	(~3), couldn't identify and doesn't mention condition (fresh or dead already)? Chris Starbird.	Load sheet states Carp or sturgeon	No	Load sheet, Daily and Weekly Summary mentions. No way to confirm.
NDNEF	About 98	SAW	Wilmington Har Cape Fear River	A	P ??	Dead				NMFS 1998 Shortnose Recovery Plan p. 53
NDNEF	About 98	SAW	Wilmington Har Cape Fear River	A	C	Dead				NMFS 1998 Shortnose Recovery Plan p. 53
NDNEF	About 98	SAJ or SAS	Kings Bay	A	H ??	Dead				NMFS 1998 Shortnose Recovery Plan p. 52 Chris Slay pers com

Sp=sturgeon species
 A=Atlantic sturgeon (*Acipenser oxyrinchus oxyrinchus*)
 S=Shortnose sturgeon (*Acipenser brevirostrum*)

G=Gulf sturgeon (*Acipenser oxyrinchus desotoi*)
 NT = Non-take incident by dredge
 SAC=Charleston

SAW=Wilmington
SAS=Savannah
SAJ=Jacksonville
SAM=Mobile
NAE=New England
NAO=Norfolk
NAN=New York
NAP=Philadelphia
H=Hopper
P=Hydraulic Cutterhead pipeline
C=Mechanical clamshell or bucket, bucket and barge
DMA=Dredged material disposal area
NDNEF=No documentation, no evidence found to confirm citation

APPENDIX D

MONITORING SPECIFICATIONS FOR HOPPER DREDGES

I. EQUIPMENT SPECIFICATIONS

A. Baskets or screening

Baskets or screening must be installed over the hopper inflows with openings no smaller than 4 inches by 4 inches to provide 100% coverage of all dredged material and shall remain in place during all dredging operations. Baskets/screening will allow for better monitoring by observers of the dredged material intake for sea turtles, sturgeon and their remains. The baskets or screening must be safely accessible to the observer and designed for efficient cleaning.

B. Draghead

The draghead of the dredge shall remain on the bottom **at all times** during a pumping operation, except when:

- 1) the dredge is not in a pumping operation, and the suction pumps are turned completely off;
- 2) the dredge is being re-oriented to the next dredge line during borrow activities; and
- 3) the vessel's safety is at risk (i.e., the dragarm is trailing too far under the ship's hull).

At initiation of dredging, the draghead shall be placed on the bottom during priming of the suction pump. If the draghead and/or dragarm become clogged during dredging activity, the pump shall be shut down, the dragarms raised, whereby the draghead and/or dragarm can be flushed out by trailing the dragarm along side the ship. If plugging conditions persist, the draghead shall be placed on deck, whereby sufficient numbers of water ports can be opened on the draghead to prevent future plugging.

Upon completion of a dredge track line, the drag tender shall:

- 1) throttle back on the RPMs of the suction pump engine to an idling speed (e.g., generally less than 100 RPMs) **prior to** raising the draghead off the bottom, so that no flow of material is coming through the pipe into the dredge hopper. Before the draghead is raised, the vacuum gauge on the pipe should read zero, so that no suction exists both in the dragarm and draghead, and no suction force exists that can impinge a turtle on the draghead grate;
- 2) hold the draghead firmly on the bottom with no flow conditions for approximately 10 to 15 seconds before raising the draghead; then, raise the draghead quickly off the bottom and up to a mid-water column level, to further reduce the potential for any adverse interaction with nearby turtles;
- 3) re-orient the dredge quickly to the next dredge line; and
- 4) re-position the draghead firmly on the bottom prior to bringing the dredge pump to normal pumping speed, and re-starting dredging activity.

C. Floodlights

Floodlights must be installed to allow the NMFS-approved observer to safely observe and monitor the baskets or screens.

D. Intervals between dredging

Sufficient time must be allotted between each dredging cycle for the NMFS-approved observer to inspect and thoroughly clean the baskets and screens for sea turtles and/or turtle parts and document the findings. Between each dredging cycle, the NMFS-approved observer should also examine and clean the dragheads and document the findings.

II. OBSERVER PROTOCOL

A. Basic Requirement

A NMFS-approved observer with demonstrated ability to identify sea turtle and sturgeon species must be placed aboard the dredge(s) being used, starting immediately upon project commencement to monitor for the presence of listed species and/or parts being entrained or present in the vicinity of dredge operations.

B. Duty Cycle

Observers are required at times and locations outlined in the ITS. While onboard, the observer must work a shift schedule appropriate to allow for the observation of at least 50% of the dredge loads (e.g., 12 hours on, 12 hours off). The ACOE shall require of the dredge operator that, when the observer is off watch, the cage shall not be opened unless it is clogged. The ACOE shall also require that if it is necessary to clean the cage when the observer is off watch, any aquatic biological material is left in the cage for the observer to document and clear out when they return on duty. In addition, the observer shall be the only one allowed to clean off the overflow screen.

C. Inspection of Dredge Spoils

During the required inspection coverage, the trained NMFS-approved observer shall inspect the galvanized screens and baskets at the completion of each loading cycle for evidence of sea turtles or shortnose sturgeon. The Endangered Species Observation Form shall be completed for each loading cycle, whether listed species are present or not. If any whole (alive or dead) or turtle parts are taken incidental to the project(s), NMFS Protected Resources Division must be contacted by phone (978-281-9328) or e-mail (incidental.take@noaa.gov) within 24 hours of the take. An incident report for sea turtle/shortnose sturgeon take (Appendix D) shall also be completed by the observer and sent via FAX (978) 281-9394 or e-mail (incidental.take@noaa.gov) within 24 hours of the take. Incident reports shall be completed for every take regardless of the state of decomposition. NMFS will determine if the take should be attributed to the incidental take level, after the incident report is received. Every incidental take (alive or dead, decomposed or fresh) should be photographed, and photographs shall be sent to NMFS either electronically (incidental.take@noaa.gov) or through the mail. Weekly reports, including all completed load sheets, photographs, and relevant incident reports, as well as a final

report, shall be submitted to NMFS NER, Protected Resources Division, 55 Great Republic Drive, Gloucester, MA 01930-2298.

D. Information to be Collected

For each sighting of any endangered or threatened marine species (including whales as well as sea turtles), record the following information on the Endangered Species Observation Form (Appendix D):

- 1) Date, time, coordinates of vessel
- 2) Visibility, weather, sea state
- 3) Vector of sighting (distance, bearing)
- 4) Duration of sighting
- 5) Species and number of animals
- 6) Observed behaviors (feeding, diving, breaching, etc.)
- 7) Description of interaction with the operation

E. Disposition of Parts

If any whole turtles or sturgeon (alive or dead, decomposed or fresh) or turtle or shortnose sturgeon parts are taken incidental to the project(s), NMFS Protected Resources must be contacted within 24 hours of the take (phone: 978-281-9328 or e-mail (incidental.take@noaa.gov)). All whole dead sea turtles or sturgeon, or turtle or shortnose sturgeon parts, must be photographed and described in detail on the Incident Report of Sea Turtle Mortality (Appendix D). The photographs and reports should be submitted by email (incidental.take@noaa.gov) or mail (Attn: Section 7 Coordinator, NMFS, Protected Resources Division, 55 Great Republic Drive, Gloucester, MA 01930-2298). After NMFS is notified of the take, it may instruct the observer to save the animal for future analysis if there is freezer space. Disposition of dead sea turtles/ sturgeon will be determined by NMFS at the time of the take notification. If the species is unidentifiable or if there are entrails that may have come from a turtle, the subject should be photographed, placed in plastic bags, labeled with location, load number, date and time taken, and placed in cold storage.

Live turtles (both injured and uninjured) should be held onboard the dredge until transported as soon as possible to the appropriate stranding network personnel for rehabilitation (Appendix C). No live turtles should be released back into the water without first being checked by a qualified veterinarian or a rehabilitation facility. The NMFS Stranding Network Coordinator ((978) 282-8470) should also be contacted immediately for any marine mammal injuries or mortalities.

III. OBSERVER REQUIREMENTS

Submission of resumes of endangered species observer candidates to NMFS for final approval ensures that the observers placed onboard the dredges are qualified to document takes of endangered and threatened species, to confirm that incidental take levels are not exceeded, and to provide expert advice on ways to avoid impacting endangered and threatened species. NMFS does not offer certificates of approval for observers, but approves observers on a case-by-case

basis.

A. Qualifications

Observers must be able to:

- 1) differentiate between leatherback (*Dermochelys coriacea*), loggerhead *Caretta caretta*), Kemp's ridley (*Lepidochelys kempii*), green (*Chelonia mydas*), and hawksbill (*Eretmochelys imbricata*) turtles and their parts, and shortnose (*Acipenser brevirostrum*) and Atlantic (*Acipenser oxyrinchus oxyrinchus*) sturgeon and their parts;
- 2) handle live sea turtles and sturgeon and resuscitate and release them according accepted procedures;
- 3) correctly measure the total length and width of live and whole dead sea turtle and sturgeon species;
- 4) observe and advise on the appropriate screening of the dredge's overflow, skimmer funnels, and dragheads; and
- 5) identify marine mammal species and behaviors.

B. Training

Ideally, the applicant will have educational background in marine biology, general experience aboard dredges, and hands-on field experience with the species of concern. For observer candidates who do not have sufficient experience or educational background to gain immediate approval as endangered species observers, the below observer training is necessary to be considered admissible by NMFS. We can assist the ACOE by identifying groups or individuals capable of providing acceptable observer training. Therefore, at a minimum, observer training must include:

- 1) instruction on how to identify sea turtles and sturgeon and their parts;
- 2) instruction on appropriate screening on hopper dredges for the monitoring of sea turtles and sturgeon (whole or parts);
- 3) demonstration of the proper handling of live sea turtles and sturgeon incidentally captured during project operations. Observers may be required to resuscitate sea turtles according to accepted procedures prior to release;
- 4) instruction on standardized measurement methods for sea turtle and sturgeon lengths and widths; and
- 5) instruction on how to identify marine mammals; and
- 6) instruction on dredging operations and procedures, including safety precautions onboard a vessel.

APPENDIX E

Sea Turtle Handling and Resuscitation

It is unlikely that sea turtles will survive entrainment in a hopper dredge, as the turtles found in the dragheads are usually dead, dying, or dismantled. However, the procedures for handling live sea turtles follow in case the unlikely event should occur. These guidelines are adapted from 50 CFR § 223.206(d)(1).

Please photograph all turtles (alive or dead) and turtle parts found during dredging activities and complete the Incident Report of Sea Turtle Take.

Dead sea turtles

The procedures for handling dead sea turtles and parts are described in Appendix D.

Live sea turtles

When a sea turtle is found in the dredge gear, observe it for activity and potential injuries.

- **If the turtle is actively moving**, it should be retained onboard until evaluated for injuries by a permitted rehabilitation facility. Due to the potential for internal injuries associated with hopper entrainment, it is necessary to transport the live turtle to the nearest rehabilitation facility as soon as possible, following these steps:
 - 1) Contact the nearest rehabilitation facility to inform them of the incident. If the rehabilitation personnel cannot be reached immediately, please contact NMFS stranding hotline at 866-755-6622 or NMFS Sea Turtle Stranding Coordinator at 978-281-9328.
 - 2) Keep the turtle shaded and moist (e.g., with a water-soaked towel over the eyes, carapace, and flippers), and in a confined location free from potential injury
 - 3) Contact the crew boat to pick up the turtle as soon as possible from the dredge (within 12 to 24 hours maximum). The crew boat should be aware of the potential for such an incident to occur and should develop an appropriate protocol for transporting live sea turtles.
 - 4) Transport the live turtle to the closest permitted rehabilitation facility able to handle such a case.

Do not assume that an inactive turtle is dead. The onset of rigor mortis and/or rotting flesh are often the only definite indications that a turtle is dead. Releasing a comatose turtle into any amount of water will drown it, and a turtle may recover once its lungs have had a chance to drain.

- **If a turtle appears to be comatose** (unconscious), contact the designated stranding/rehabilitation personnel immediately. Once the rehabilitation personnel has been informed of the incident, attempts should be made to revive the turtle at once. Sea turtles have been known to revive up to 24 hours after resuscitation procedures have been followed.
 - Place the animal on its bottom shell (plastron) so that the turtle is right side up and elevate the hindquarters at least 6 inches for a period of 4 up to 24 hours. The

degree of elevation depends on the size of the turtle; greater elevations are required for larger turtles.

- Periodically, rock the turtle gently left to right and right to left by holding the outer edge of the shell (carapace) and lifting one side about 3 inches then alternate to the other side.
- Periodically, gently touch the eye and pinch the tail (reflex test) to see if there is a response.
- Keep the turtle in a safe, contained place, shaded, and moist (e.g., with a water-soaked towel over the eyes, carapace, and flippers) and observe it for up to 24 hours.
- If the turtle begins actively moving, retain the turtle until the appropriate rehabilitation personnel can evaluate the animal. The rehabilitation facility should eventually release the animal in a manner that minimizes the chances of re-impingement and potential harm to the animal (i.e., from cold stunning).
- Turtles that fail to move within several hours (up to 24) must be handled in the manner described, or transported to a suitable facility for necropsy (if the condition of the sea turtle allows and the rehabilitation facility wants to necropsy the animal).

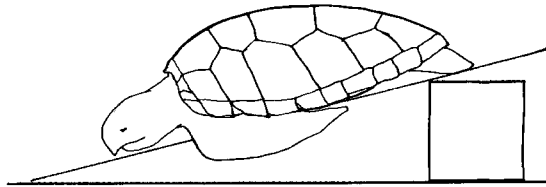

Stranding/rehabilitation contacts

NMFS Stranding Hotline: 866-755-6622 or NERStranding.staff@noaa.gov

Virginia State Coordinator: Sea Turtle Stranding and Salvage Network

Mark Swingle (Co-Coordinator, James River South and VA Eastern Shore)

Virginia Aquarium Stranding Program

717 General Booth Boulevard

Virginia Beach, VA 23451

Office: 757-437-6022; Fax: -4976

Stranding Hotline: 757-437-6159

mswingle@vbgov.com

APPENDIX F

Procedure for obtaining fin clips from sturgeon for genetic analysis

Obtaining Sample

1. Wash hands and use disposable gloves. Ensure that any knife, scalpel or scissors used for sampling has been thoroughly cleaned and wiped with alcohol to minimize the risk of contamination.
2. For any sturgeon, after the specimen has been measured and photographed, take a one-cm square clip from the pelvic fin.
3. Each fin clip should be placed into a vial of 95% non-denatured ethanol and the vial should be labeled with the species name, date, name of project and the fork length and total length of the fish along with a note identifying the fish to the appropriate observer report. All vials should be sealed with a lid and further secured with tape. Please use permanent marker and cover any markings with tape to minimize the chance of smearing or erasure.

Storage of Sample

1. If possible, place the vial on ice for the first 24 hours. If ice is not available, please refrigerate the vial. Send as soon as possible as instructed below.

Sending of Sample

1. Vials should be placed into Ziploc or similar resealable plastic bags. Vials should be then wrapped in bubble wrap or newspaper (to prevent breakage) and sent to:

Julie Carter
NOAA/NOS – Marine Forensics
219 Fort Johnson Road
Charleston, SC 29412-9110
Phone: 843-762-8547

- a. Prior to sending the sample, contact Russ Bohl at NMFS Northeast Regional Office (978-282-8493) to report that a sample is being sent and to discuss proper shipping procedures.

STURGEON SALVAGE FORM

For use in documenting dead sturgeon in the wild under ESA permit no. 1614 (version 05-16-2012)

INVESTIGATORS'S CONTACT INFORMATION Name: First _____ Last _____ Agency Affiliation _____ Email _____ Address _____ _____ Area code/Phone number _____	UNIQUE IDENTIFIER (Assigned by NMFS) DATE REPORTED: Month <input type="checkbox"/> <input type="checkbox"/> Day <input type="checkbox"/> <input type="checkbox"/> Year 20 <input type="checkbox"/> <input type="checkbox"/> DATE EXAMINED: Month <input type="checkbox"/> <input type="checkbox"/> Day <input type="checkbox"/> <input type="checkbox"/> Year 20 <input type="checkbox"/> <input type="checkbox"/>
--	---

SPECIES: (check one) <input type="checkbox"/> shortnose sturgeon <input type="checkbox"/> Atlantic sturgeon <input type="checkbox"/> Unidentified <i>Acipenser</i> species <i>Check "Unidentified" if uncertain</i> See reverse side of this form for aid in identification.	LOCATION FOUND: <input type="checkbox"/> Offshore (Atlantic or Gulf beach) <input type="checkbox"/> Inshore (bay, river, sound, inlet, etc) River/Body of Water _____ City _____ State ____ Descriptive location (be specific) _____ _____ Latitude _____ N (Dec. Degrees) Longitude _____ W (Dec. Degrees)
--	--

CARCASS CONDITION at time examined: (check one) <input type="checkbox"/> 1 = Fresh dead <input type="checkbox"/> 2 = Moderately decomposed <input type="checkbox"/> 3 = Severely decomposed <input type="checkbox"/> 4 = Dried carcass <input type="checkbox"/> 5 = Skeletal, scutes & cartilage	SEX: <input type="checkbox"/> Undetermined <input type="checkbox"/> Female <input type="checkbox"/> Male How was sex determined? <input type="checkbox"/> Necropsy <input type="checkbox"/> Eggs/milt present when pressed <input type="checkbox"/> Borescope	MEASUREMENTS: Circle unit Fork length _____ cm / in Total length _____ cm / in Length <input type="checkbox"/> actual <input type="checkbox"/> estimate Mouth width (inside lips, see reverse side) _____ cm / in Interorbital width (see reverse side) _____ cm / in Weight <input type="checkbox"/> actual <input type="checkbox"/> estimate _____ kg / lb
--	--	--

TAGS PRESENT? Examined for external tags including fin clips? <input type="checkbox"/> Yes <input type="checkbox"/> No Scanned for PIT tags? <input type="checkbox"/> Yes <input type="checkbox"/> No		
Tag # _____ _____	Tag Type _____ _____	Location of tag on carcass _____ _____

CARCASS DISPOSITION: (check one or more) <input type="checkbox"/> 1 = Left where found <input type="checkbox"/> 2 = Buried <input type="checkbox"/> 3 = Collected for necropsy/salvage <input type="checkbox"/> 4 = Frozen for later examination <input type="checkbox"/> 5 = Other (describe) _____	Carcass Necropsied? <input type="checkbox"/> Yes <input type="checkbox"/> No Date Necropsied: _____ Necropsy Lead: _____ _____	PHOTODOCUMENTATION: Photos/video taken? <input type="checkbox"/> Yes <input type="checkbox"/> No Disposition of Photos/Video: _____ _____ _____
--	---	--

SAMPLES COLLECTED? <input type="checkbox"/> Yes <input type="checkbox"/> No		
Sample _____ _____ _____ _____ _____ _____ _____ _____	How preserved _____ _____ _____ _____ _____ _____ _____ _____	Disposition (person, affiliation, use) _____ _____ _____ _____ _____ _____ _____ _____

Comments: _____

Distinguishing Characteristics of Atlantic and Shortnose Sturgeon (version 07-20-2009)

Characteristic	Atlantic Sturgeon, <i>Acipenser oxyrinchus</i>	Shortnose Sturgeon, <i>Acipenser brevirostrum</i>
Maximum length	> 9 feet/ 274 cm	4 feet/ 122 cm
Mouth	Football shaped and small. Width inside lips < 55% of bony interorbital width	Wide and oval in shape. Width inside lips > 62% of bony interorbital width
*Pre-anal plates	Paired plates posterior to the rectum & anterior to the anal fin.	1-3 pre-anal plates almost always occurring as median structures (occurring singly)
Plates along the anal fin	Rhombic, bony plates found along the lateral base of the anal fin (see diagram below)	No plates along the base of anal fin
Habitat/Range	Anadromous; spawn in freshwater but primarily lead a marine existence	Freshwater amphidromous; found primarily in fresh water but does make some coastal migrations

* From Vecsei and Peterson, 2004

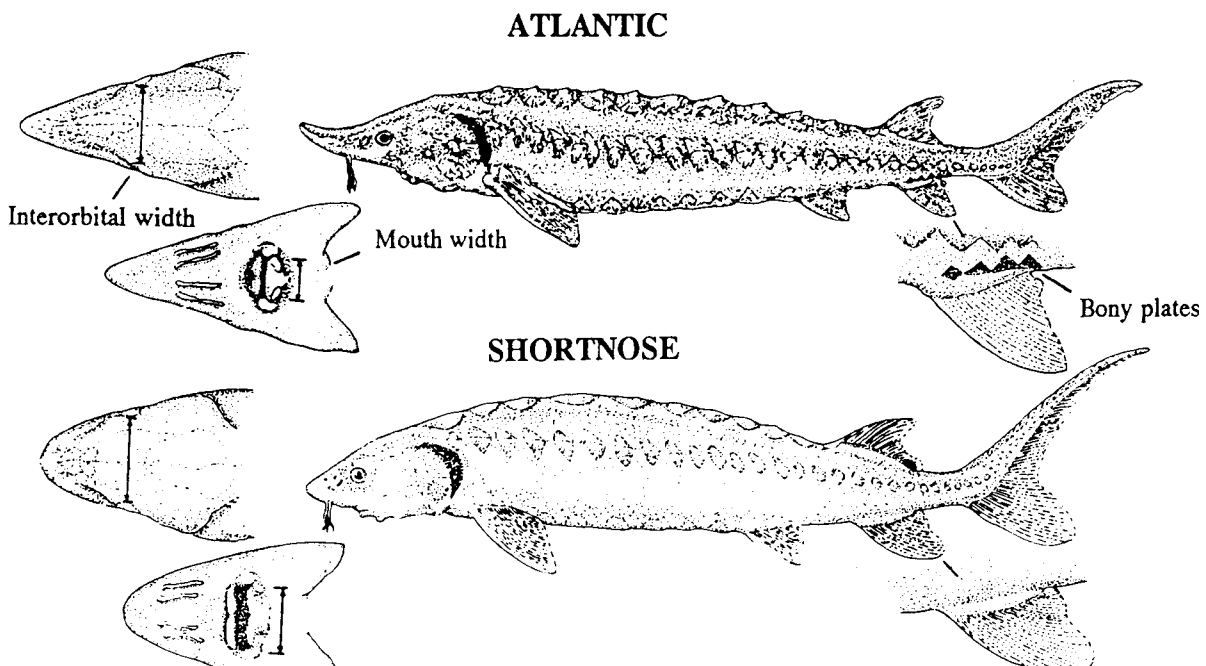

Describe any wounds / abnormalities (note tar or oil, gear or debris entanglement, propeller damage, etc.). Please note if no wounds / abnormalities are found.

Submit completed forms (within 30 days of date of investigation) to: Northeast Region Contacts – Shortnose Sturgeon Recovery Coordinator (Jessica Pruden, Jessica.Pruden@noaa.gov, 978-282-8482) or Atlantic Sturgeon Recovery Coordinator (Lynn Lankshear, Lynn.Lankshear@noaa.gov, 978-282-8473); Southeast Region Contacts- Shortnose Sturgeon Recovery Coordinator (Stephania Bolden, Stephania.Bolden@noaa.gov, 727-824-5312) or Atlantic Sturgeon Recovery Coordinator (Kelly Shotts, Kelly.Shotts@noaa.gov, 727-551-5603).

APPENDIX H
ENDANGERED SPECIES OBSERVER FORM
Sandbridge Shoals 2012-2013

Daily Report

Date: _____

Geographic Site: _____

Location: Lat/Long _____ Vessel Name _____

Weather conditions: _____

Water temperature: Surface _____ Below midwater (if known) _____

Condition of screening apparatus: _____

Incidents involving endangered or threatened species? (Circle) Yes No
(If yes, fill out Incident Report of Sea Turtle/ Sturgeon Mortality)

Comments (type of material, biological specimens, unusual circumstances, etc:)

Observer's Name: _____

Observer's Signature: _____

<u>Species</u>	<u># of Sightings</u>	<u># of Animals</u>	<u>Comments</u>
_____	_____	_____	_____
_____	_____	_____	_____
_____	_____	_____	_____
_____	_____	_____	_____
_____	_____	_____	_____
_____	_____	_____	_____
_____	_____	_____	_____
_____	_____	_____	_____
_____	_____	_____	_____
_____	_____	_____	_____

Incident Report of Sea Turtle Take

Species _____ Date _____ Time (specimen found) _____

Geographic Site _____

Location: Lat/Long _____

Vessel Name _____ Load # _____

Begin load time _____ End load time _____

Begin dump time _____ End dump time _____

Sampling method _____

Condition of screening _____

Location where specimen recovered _____

Draghead deflector used? YES NO Rigid deflector draghead? YES NO

Condition of deflector _____

Weather conditions _____

Water temp: Surface _____ Below midwater (if known) _____

Species Information: *(please designate cm/m or inches.)*

Head width _____ Plastron length _____

Straight carapace length _____ Straight carapace width _____

Curved carapace length _____ Curved carapace width _____

Condition of specimen/description of animal (please complete attached diagram)

Turtle Decomposed: NO SLIGHTLY MODERATELY SEVERELY

Turtle tagged: YES NO *Please record all tag numbers.* Tag # _____

Genetic sample taken: YES NO

Photograph attached: YES NO

(please label species, date, geographic site and vessel name on back of photograph)

Comments/other (include justification on how species was identified) _____

Observer's Name _____

Observer's Signature _____

Incident Report of Sea Turtle Take

Draw wounds, abnormalities, tag locations on diagram and briefly describe below.

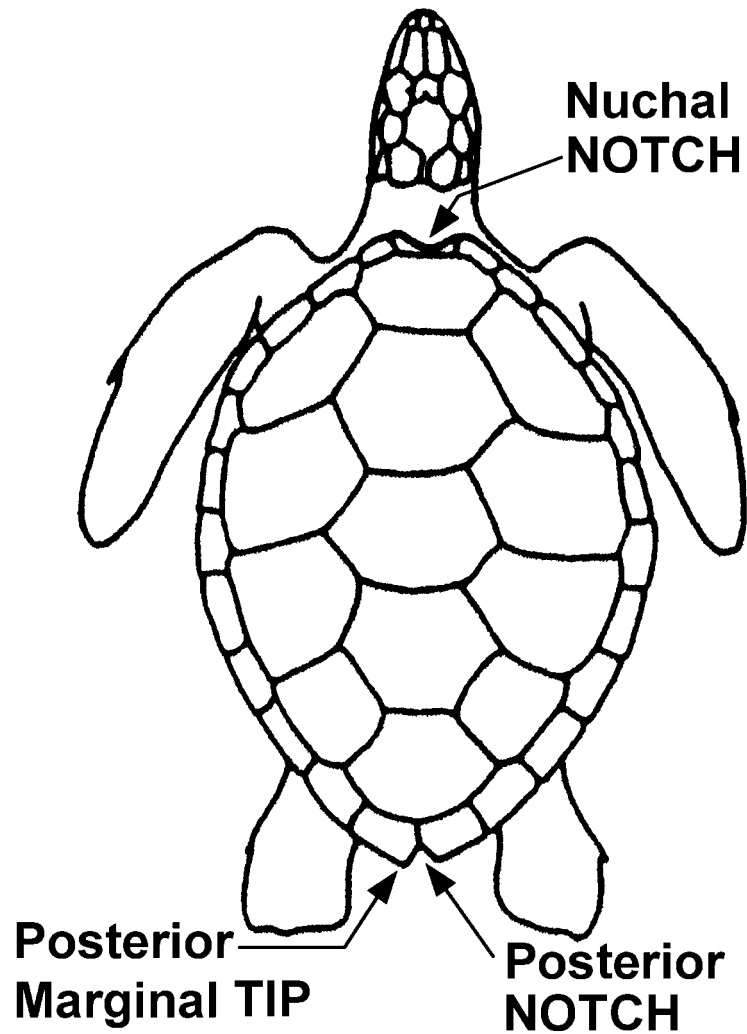

Description of animal:

Incident Report of Sturgeon Take

Photographs should be taken and the following information should be collected from all sturgeon (alive and dead)

Date _____ Time (specimen found) _____

Geographic Site _____

Location: Lat/Long _____

Vessel Name _____ Load # _____

Begin load time _____ End load time _____

Begin dump time _____ End dump time _____

Sampling method _____

Condition of screening _____

Location where specimen recovered _____

Draghead deflector used? YES NO Rigid deflector draghead? YES NO
Condition of deflector _____

Weather conditions _____

Water temp: Surface _____ Below midwater (if known) _____

Species Information: *(please designate cm/m or inches.)*

Fork length (or total length) _____ Weight _____

Condition of specimen/description of animal

Fish Decomposed: NO SLIGHTLY MODERATELY SEVERELY

Fish tagged: YES / NO *Please record all tag numbers.* Tag # _____

Genetic sample taken: YES NO

Photograph attached: YES / NO

(please label species, date, geographic site and vessel name on back of photograph)

Comments/other (include justification on how species was identified)

Observer's Name _____ Observer's Signature _____

Draw wounds, abnormalities, tag locations on diagram and briefly describe below

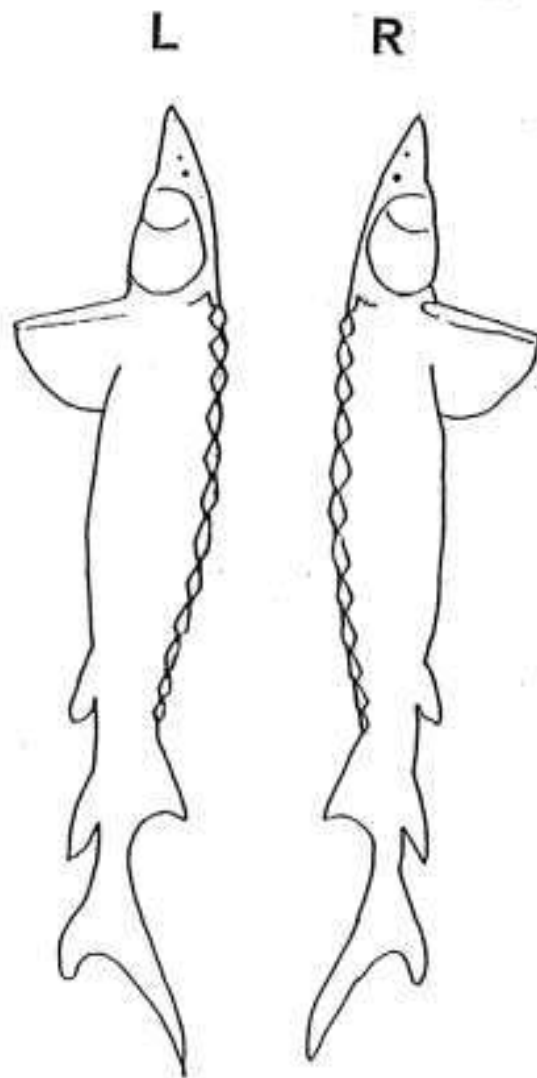

Description of fish condition: