



Pacific Marine Environmental Laboratory

FINAL Project Instructions

Date Submitted: February 14, 2014
Platform: NOAA Ship *Oscar Dyson*
Project Number: DY-14-05
Project Title: *EcoFOCI Spring Moorings*
Project Dates: May 6, 2014 – May 17, 2014

Prepared by: William Floering Dated: 4/4/14
William Floering
Chief Scientist
PMEL

Approved by: Phyllis J. Stabeno Dated: 4/14/14
Dr. Phyllis Stabeno
Program Lead, EcoFOCI
PMEL

Approved by: Christopher Sabine Dated: 4/14/14
Dr. Christopher Sabine
Director
PMEL

Approved by: _____ Dated: _____
Captain Wade J. Blake, NOAA
Commanding Officer
Marine Operations Center – Pacific

I. Overview

- A. FOCI Spring Moorings May 6 – May 17, 2014
- B. Service Level Agreements
Of the 12 DAS scheduled for this project, 0 DAS are funded by the program and 12 DAS are funded by OMAO. This project is estimated to exhibit a High Operational Tempo.
- C. Operating Area (include optional map/figure showing op area)

Gulf of Alaska and Eastern Bering Sea - map shown below:

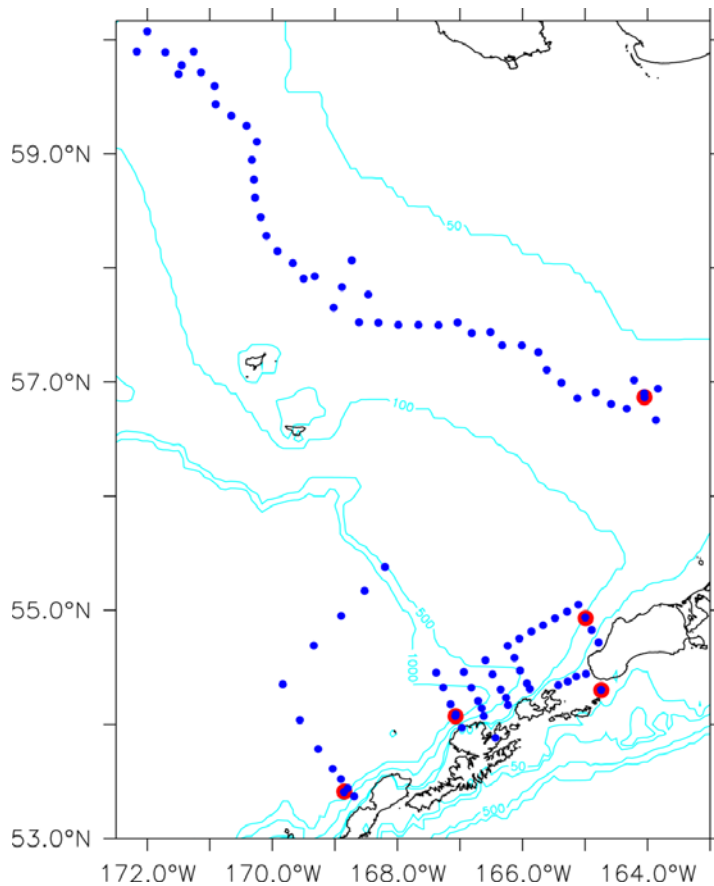

D. Summary of Objectives:

The primary objectives of this cruise will be to deploy moorings in several locations in the Bering Sea.

Upon leaving Dutch Harbor, one mooring will be deployed in Unimak Pass. CTDs will be conducted after each mooring deployment.

The cruise will then proceed towards the Bering Sea shelf, where the “Unimak Box” of CTDs will be conducted. The UBP-1A mooring will be deployed on the eastern line of the “Unimak Box”.

Mooring deployment is planned for “Site 2” with multiple CTDs, CalVETs, and bongo-tows also planned at the site. Weather permitting, the 70m CTD Line will be followed and sampled from Site 2 northward as far as the ice will allow.

Upon completion of the 70m line, the “L/Dog Leg Line” will be conducted from the shelf-break toward the southwest to the Aleutians. Two moorings (ULP-1A and BSP-6A) will then be deployed. Finally, 4 transects crossing Bering Canyon will be conducted, including CTDs and multinet tows. Two CTD drifters will be deployed in 1500 meter plus water.

CTDs will include collection of water samples for Nutrients, Chlorophyll, Primary Productivity experiments. Throughout the cruise, water samples for analysis of DIC/TA will be collected from the underway system.

E. Participating Institutions:

NOAA - Pacific Marine Environmental Laboratory (PMEL)
7600 Sand Point Way N.E., Seattle, Washington 98115-6439

NOAA - Alaska Fisheries Science Center (AFSC)
7600 Sand Point Way N.E., Seattle, Washington 98115-0070

University of Alaska (UAF)
505 South Chandalar Drive
Fairbanks, AK 99775

Bigelow Laboratory for Ocean Sciences (BLOS)
60 Bigelow Dr., East Boothbay, ME 04544

F. Personnel/Science Party:

Name (Last, First)	Title	Date Aboard	Date Disembark	Gender	Affiliation	Nationality
William Floering	Chief Sci.	5/2/14	5/18/14	M	PMEL	USA
Shaun Bell	Sci	5/4/14	5/18/14	M	PMEL	USA
Kim Martini	Sci	5/4/14	5/18/14	F	PMEL	USA
Peter Proctor	Sci	5/4/14	5/18/14	M	PMEL	USA
Morgan Busby	Sci	5/4/14	5/18/14	M	AFSC	USA
Colleen Harpold	Sci	5/4/14	5/18/14	F	AFSC	USA
Steven Baer	Sci	5/5/14	5/18/14	M	BLOS	USA
Natalie Monacci	Sci	5/3/14	5/18/14	F	UAF	USA

Comment [LG1]: All dates are TBD? Do they align with project dates? Please add.

G. Administrative

1. Points of Contacts

Bill Floering (Chief Scientist), PMEL, 7600 Sand Point Way NE, Bldg 3, Seattle WA 98115, ph: 206-526-6480, William.Floering@noaa.gov

Janet Duffy-Anderson (Alternate), AFSC, 7600 Sand Point Way NE, Bldg 4, Seattle WA 98115, ph: 206-526-6465, Janet.Duffy-Anderson@noaa.gov

Jeff Napp, AFSC, 7600 Sand Point Way NE, Bldg 4, Seattle WA 98115, ph: 206-526-4148, Jeff.Napp@noaa.gov

Phyllis Stabeno, PMEL, 7600 Sand Point Way NE, Bldg 3, Seattle WA 98115, ph: 206-526-6453, Phyllis.Stabeno@noaa.gov

2. Diplomatic Clearances

None required

3. Licenses and Permits
None required

II. Operations

A. Project Itinerary

Departure: May 6, 2014 0900 Dutch Harbor, AK
Arrival: May 17, 2014 0900 Dutch Harbor, AK

B. Staging and De-staging

Container with equipment will be shipped directly to Dutch Harbor from Seattle. Loading shall occur as appropriate before departure. The scientific party will arrive at least two days early to assist with loading and preparation. The scientific party will be responsible for arranging vehicles for transporting themselves and equipment to the ship. Equipment will be offloaded upon arrival in Dutch Harbor, and transported to proper shipping avenues by the scientific party. Ship's crew and crane will be required to assist with loading and offloading. To facilitate pre cruise equipment assembly and set up a crane operator may be needed for short periods during normal day work hours on May 3rd, 4th and 5th.

C. Operations to be Conducted

Due to the time of year that this cruise occurs, the amount of mooring work accomplished and the order of operations will be highly dependent on ice, weather and daylight conditions. Decisions on which operations to be conducted will be made on a daily basis based on assessment of conditions and priorities. A full list of Station IDs, including locations is provided as Appendix I.

The ship will depart on Tuesday, May 6, 2014 at 0900.

- a) **Unimak Pass Mooring:** The mooring in Unimak Pass will be deployed. A CTD will be taken after mooring deployment. **Deploy drifter.**
- b) **Drifter Deployments:** Four 40m drogue drifters will be deployed at specified locations. Two to three Argo drifters will be deployed.
- c) **Unimak CTD Box:** A CTD (with nutrient and chlorophyll samples) will be deployed at each of 18 stations in a "box" around Unimak Pass. A 20/60 cm bongo will be deployed at every station within Unimak Pass and every other station on the other sides of the box for collection of mesozooplankton.
- d) **Unimak Box Mooring:** The mooring on the Unimak "Box E" Line will be deployed.
- e) **FOCI Bering Sea Site 2:** Depending on arrival timing, the cruise will continue with mooring operations or the CTD "box". Two moorings will be deployed, none recovered. Prior to mooring operations, calibration CTDs (with nutrient and chlorophyll samples) will be completed. Mooring operations will consist of deploying one surface and one subsurface mooring. After the completion of all mooring operations, a CTD, with nutrient and chlorophyll samples, a MARMAP Bongo tow with 20 and 60 cm bongos and triplicate CalVET tows will be completed approximately 0.5 mile from the mooring site. At the four stations surrounding Site 2, a CTD and 20/60 bongo tow will be completed.
- f) **Microplankton sampling:** Samples for microphytoplankton and microzooplankton will be taken from the CTD Niskin cast at FOCI Bering Sea Site 2 and 4. At each mooring site and at the four surrounding stations, samples

will be taken from the surface bottle. When a subsurface chlorophyll maximum occurs, a second sample will also be taken from the Niskin bottle in or closest to the depth of the chlorophyll maximum.

- g) **70 Meter Isobath Line:** A CTD will be deployed at each station along the isobath with collection of samples for salinity, chlorophyll, and nutrients. A 20/60 cm bongo will be deployed at every other station for collection of mesozooplankton. CTDs will start from mooring Site 2, continuing northward as time and ice conditions allow.
- h) **“Dog Leg” Line:** Up to 11 CTD stations may be sampled if time permits. Locations are in Appendix I.
- i) **FOCI Bering Sea Site 6:** The mooring at Site 6 will be deployed at 1000m depth. A CTD will be taken after mooring deployment. **Deploy drifter.**
- j) **Unalaska Mooring:** The mooring on the Unalaska Transect will be deployed at 1000m depth. A CTD will be taken after mooring deployment. **Deploy drifter.**
- k) **Bering Canyon CTD Transects:** A CTD (with nutrient and chlorophyll samples) will be deployed at each of 15 stations (5 stations/3 lines). A multinet will be deployed at 3 stations per line (9 multinet stations total).
- l) **Unimak Box W Transect:** A CTD (with nutrient and chlorophyll samples) will be deployed at each of 5 stations. A multinet will be deployed at 3 stations. Locations are in Appendix I.
- m) **Multinet:** A multinet (see Appendix II, midi size) will be deployed at select stations (locations listed in Appendix I). The Multi Plankton Sampler MultiNet Type Midi will be used at select stations to determine vertical distribution of fish larvae and zooplankton (.333 or .505-mm mesh). The sampling will be focused over Bering Canyon, approximately 12 stations. The exact number and location will be determined by the scientific party at sea and may be adjusted depending on conditions and cruise priorities.

We request assistance from the ship’s Electronics Technician, Survey Technician and / or Deck Department as needed to help set up the electronic and physical termination, rig the MultiNet for fishing, and help trouble shoot the MultiNet . We also request help switching between the Bongo and MultiNet on the aft Oceo winch as needed during the cruise.

The MultiNet has a steel frame with a square mouth opening of .5 x .5 m that can be used with up to 5 nets to sample different water depths. This net requires a conducting cable and will be deployed off the aft oceanographic winch that the Bongo array is usually attached to. Before deployment of the Multinet, the Seacat and Bongo array will be detached and the MultiNet will be electronically and physically terminated to that conducting wire. For the stations over Bering Canyon, the MultiNet will be used in place of the Bongo (after the CTD). If we have gear problems with the Multinet, the Bongo will be used as a backup. When we are done using the MultiNet, the Seacat and Bongo Array will be re-connected to continue the rest of our routine sampling. The MultiNet plankton samples will be processed in a similar manner as those from the Bongo, filtered and preserved in 1.8% Buffered Formaldehyde.

Winch / Fishing Rates

- Ship Speed: ~2.5-3 knots (may need to be adjusted based on conditions)
- Wire Payout Rate: 20 m per. min.
- Wire Retrieval Rate: no more than 10 m per min., possibly slower TDB by scientific party based on how much water is being filtered.
- Target Wire Angle 55° (acceptable range 50°-60°)

-Maximum Gear Depth: ~ 300 m or 10m off bottom

MOA Buttons Needed for SCS

- In the water (surface)
- At Depth
- Net 1
- Net 2
- Net 3
- Net 4
- Net 5
- Out of the water (surface)

Approximate Sampling Intervals (may change depending on bottom depth and sampling needs):

- 0-25 m
- 25-50 m
- 50-100 m
- 100-200 m
- 200-300 m

- n) **Primary production:** Experiments using stable (non-radioactive) isotopes (¹³C and ¹⁵N) will be conducted at a subset of stations. Water samples will be collected from Niskin bottles, isotope added, then incubated in a deck-board clear plastic tank cooled with surface seawater. At end of incubation, samples will be filtered and filters stored frozen at -20°C or cooler.
- o) The order of operations may change due to weather.
- p) Possible deployment of National Marine Mammal Laboratory (NMML) mooring: NMML has requested we replace a mooring used to listen for northern right whales that was fished up by a trawler this past winter. The desired location is 57.67 N, 164.72 W. Chief Scientist and CO will determine the actual location and when or if the mooring can be deployed during the cruise.

D. Dive Plan

All dives are to be conducted in accordance with the requirements and regulations of the NOAA Diving Program (<http://www.ndc.noaa.gov/dr.html>) and require the approval of the ship's Commanding Officer. (This statement must remain in all project instructions)

Dives are not planned for this project.

E. Applicable Restrictions

Conditions which preclude normal operations: Poor weather, equipment failure, unforeseen conditions, and ice coverage would all preclude normal operations. Poor weather would have to be waited out or the project track would have to be modified to provide the best weather possible. A-frame or winch failures would need to be addressed immediately for the project to continue. Ice coverage would negate the ability to pop moorings. These would have to be recovered later in the project (depending on ice forecasts) or by another vessel.

III. Equipment

A. Equipment and Capabilities provided by the ship

- Oceanographic winch with slip rings and 3-conductor cable terminated for CTD,
- 12 Khz hull mounted Edgetech Acoustic release transducer,

- Oceanographic winch with slip rings and 3-conductor cable terminated for the SBE19plus for net tow operations,
- Sea-Bird Electronics' SBE 911plus CTD system with stand, each CTD system should include underwater CTD, weights, and pinger. There should be a deck unit for the system,
- 5 or 10-liter Niskin sampling bottles for use with rosette (10 plus 4 spares),
- Conductivity and temperature sensor package to provide dual sensors on the CTD (primary),
- For meteorological observations: 2 anemometers (one R. M. Young system interfaced to the SCS), calibrated air thermometer (wet-and dry-bulb) and a calibrated barometer and/or barograph,
- Freezer space for storage of biological and chemical samples (blast and storage freezers, -20° C and -80°C), turned on and operating,
- SIMRAD ES-60 and EK-60 echosounders,
- SIMRAD ME-70 Downward-Facing Multi-Beam Sonar,
- RD Instruments' ADCP written to disk,
- Scientific Computer System (SCS),
- Minimum of 2 computers with internet and e-mail access,
- Removable stern platform (in place),
- Laboratory space with storage space,
- Sea-water hoses and nozzles to wash nets,
- Adequate deck lighting for night-time operations,
- Navigational equipment including GPS and radar,
- Safety harnesses for working on quarterdeck and fantail,
- 2 computer work stations in the acoustics lab with internet and printer functions
- Ship's crane(s) used for loading and/or deploying.

B. Equipment and Capabilities provided by the scientists

- Sea-Bird Electronics' SBE-19plus SEACAT system,
- Fluorometer, light meter and dual oxygen sensors to be mounted on CTD,
- Conductivity and temperature sensor package to provide dual sensors on the CTD (backup),
- 60-cm bongo sampling arrays,
- 20 cm bongo arrays,
- Manual wire angle indicator,
- CalVET net array,
- Surface mooring (FOCI biophysical platforms),
- Subsurface moorings,
- Miscellaneous scientific sampling and processing equipment,
- Chlorophyll and nutrient sampling equipment,
- Clear plastic incubator (modified aquarium) ~ 4'x 2'x 2' cooled with surface seawater for primary production experiments. Will be used on deck in an uncovered area with surface seawater available.
- Winkler Oxygen Analysis rig,
- pCO₂ system installed in flow-through system.
- Ocean Drifters

IV. Hazardous Materials

A. Policy and Compliance

The Chief Scientist is responsible for complying with FEC 07 Hazardous Materials and Hazardous Waste Management Requirements for Visiting Scientific Parties (or the OMAO procedure that supersedes it). By Federal regulations and NOAA Marine and Aviation Operations policy, the ship may not sail without a complete inventory of all hazardous materials by name and quantity, MSDS, appropriate spill cleanup materials (neutralizing agents, buffers, or absorbents) in amounts adequate to address spills of a size equal to the amount of chemical

brought aboard, and chemical safety and spill response procedures. . Documentation regarding those requirements will be provided by the Chief of Operations, Marine Operations Center, upon request.

Per OMAO procedure, the scientific party will include with their project instructions and provide to the CO of the respective ship 30 days before departure:

- List of chemicals by name with anticipated quantity
- List of spill response materials, including neutralizing agents, buffers, and absorbents
- Chemical safety and spill response procedures, such as excerpts of the program’s Chemical Hygiene Plan or SOPs relevant for shipboard laboratories
- For bulk quantities of chemicals in excess of 50 gallons total or in containers larger than 10 gallons each, notify ship’s Operations Officer regarding quantity, packaging and chemical to verify safe stowage is available as soon as chemical quantities are known.

Upon embarkation and prior to loading hazardous materials aboard the vessel, the scientific party will provide to the CO or their designee:

- An inventory list showing actual amount of hazardous material brought aboard
- An MSDS for each material
- Confirmation that neutralizing agents and spill equipment were brought aboard sufficient to contain and cleanup all of the hazardous material brought aboard by the program
- Confirmation that chemical safety and spill response procedures were brought aboard

Upon departure from the ship, scientific parties will provide the CO or their designee an inventory showing that all chemicals were removed from the vessel. The CO’s designee will maintain a log to track scientific party hazardous materials. MSDS will be made available to the ship’s complement, in compliance with Hazard Communication Laws.

Scientific parties are expected to manage and respond to spills of scientific hazardous materials. Overboard discharge of hazardous materials is not permitted aboard NOAA ships.

B. Inventory

Common Name of Material	Qty	Notes	Trained Individual	Spill control
Lithium 9v Batteries	8	In SeaBird and Wetlabs Instruments	Wm. Floering	N/A
Lithium AA Batteries	96	In SeaBird instruments Microcats Saft LS14500	Wm. Floering	N/A
Lithium D Cell Batteries	150	In RCM9 & Peggy	Wm. Floering	N/A
Sodium Thiosulfate	1L of 0.16M		Natalie Monacci	ST
Potassium Iodate	1L of 0.0003M	Oxidizing, keep away from combustibles	Natalie Monacci	PI
Sulfuric Acid	0.5L of 5M	Clean up with Sodium Bicarbonate	Natalie Monacci	A
Sodium Hydroxide	0.5L of 8M	Neutralize with available acid	Natalie Monacci	B
Manganese Chloride	1L of 3M	Sweep up in case of spill	Natalie Monacci	MC

Common Name of Material	Qty	Notes	Trained Individual	Spill control
Mercuric Chloride	0.1L 10% Soln	See 'M' below	Natalie Monacci	M
Manganese Chloride	1L of 3M	For use with Oxygen titrations	Wm Floering	
Sodium Iodide/NaOH Soln	1L of 8M	For use with Oxygen titrations	Wm Floering	B
Sulfuric Acid	1L of 5M	For use with Oxygen titrations	Wm Floering	A
Sodium Thiosulfate	1L of 0.11M	For use with Oxygen titrations	Wm Floering	ST
Potassium Iodate	1L of 0.00167M	For use with Oxygen titrations	Wm Floering	PI
Dihydrogen Oxide	20L	For use with Oxygen titrations	Wm Floering	W
Formaldehyde	30gal of 37%	For use with sample preservation	Morgan Busby	F
Ethanol	4-1gal jugs @ 100%	For use with sample preservation	Morgan Busby	E
Sodium Borate	5Gal 6% Soln	For use with sample preservation	Morgan Busby	B
Sodium Borate	500g Dry Powder	For use with sample preservation	Morgan Busby	B
Lugol's solution (mixture of Lugol's iodine, acetic acid)	200 ml	For use with sample preservation	Colleen Harpold	W
¹³ C (bicarbonate)	10 g dry powder (2 x 5g)	For primary production expts	Steven Baer	W
¹⁵ N (nitrate)	1 g dry powder	For primary production expts	Steven Baer	W
Ammonium sulfate	.5 gms	For primary production expts	Steven Baer	W

C. Chemical safety and spill response procedures

A: ACID

- Wear appropriate protective equipment and clothing during clean-up. Keep upwind. Keep out of low areas.
- Ventilate closed spaces before entering them.
- Stop the flow of material, if this is without risk. Dike the spilled material, where this is possible.
- **Large Spills:** Dike far ahead of spill for later disposal. Use a non-combustible material like vermiculite, sand or earth to soak up the product and place into a container for later disposal.
- **Small Spills:** Wipe up with absorbent material (e.g. cloth, fleece). Clean surface thoroughly to remove residual contamination.
- Never return spills in original containers for re-use.

- Neutralize spill area and washings with soda ash or lime. Collect in a non-combustible container for prompt disposal.
- J. T. Baker NEUTRASORB® acid neutralizers are recommended for spills of this product.

B:Base

- Use proper PPE.
- Ventilate area.
- Neutralize with dilute acid such as HCl if possible.
- Absorb with cat litter or vermiculite.
- Vacuum or sweep up material and place into suitable disposal container.
- Do not breath dust.
- Do not get water on spilled substances.

M: Mercury

- Spills: Pick up and place in a suitable container for reclamation or disposal in a method that does not generate dust. Sprinkle area with sulfur or calcium polysulfide to suppress mercury. Use Mercury Spill Kit if need be.

F: Formalin/Formaldehyde

- Ventilate area of leak or spill. Remove all sources of ignition.
- Wear appropriate personal protective equipment.
- Isolate hazard area. Keep unnecessary and unprotected personnel from entering. Contain and recover liquid when possible.
- Use non-sparking tools and equipment. Collect liquid in an appropriate container or absorb with an inert material (e. g., vermiculite, dry sand, earth), and place in a chemical waste container.
- Do not use combustible materials, such as saw dust.

PI:Potassium Iodate

- Avoid Contact with combustibles (wood, paper, clothing ...).
- Keep substance damp with water spray.
- Vacuum or sweep up material and place into suitable disposable container (plastic bag).

MC:Mercuric Chloride

- Vacuum or sweep up material and place into suitable disposable container (plastic bag).
- Wear SCBA or other appropriate breathing apparatus and PPE.
- Avoid breathing dust.
- Keep in closed container for disposal.

ST: Sodium Thiosulfate

- Ventilate area of leak or spill.
- Wear protective gloves and clean body-covering
- Use chemical safety goggles. Maintain eye wash fountain and quick-drench facilities in work area.
- Recover liquid or particulate in 5 gallon bucket. Absorb with a kitty litter and place in disposable bag. Do not use combustible materials, such as saw dust to absorb.

W: Water

- Absorb the liquid and wash with water
- Wear PPE

E: Ethanol

- Eliminate all ignition sources
- Wear PPE
- Dilute with water

Inventory of Spill Kit supplies:

Product Name	Amount	Chemicals it is useful against	Amount it can clean up
Formalex	1.5 Gal	Formaldehyde	15 gal
FanPads	1 roll	Formaldehyde	825 ml
3M Sorbent Pads	1 box	Ethanol, Etc	Varies
Goggles	1 pair	All	N/A
Lab Coats	2	All	N/A
Plastic Bags	1 box	All – for used absorbents	Varies
Cat Litter	25 lbs	All	Varies
Spilfyter Kolorsafe Acid	10 lbs	Acids	4L
Spilfyter Kolorsafe Base	10 lbs	Bases	4L
Gloves, Apron	1 ea	All	N/A
Dustpan/ Brush	1 ea	All	N/A

Upon embarkation and prior to loading hazardous materials aboard the vessel, the scientific party will provide to the CO or their designee:

- An inventory list showing actual amount of hazardous material brought aboard
- An MSDS for each material
- Confirmation that neutralizing agents and spill equipment were brought aboard sufficient to contain and cleanup all of the hazardous material brought aboard by the program.

Upon departure from the ship, scientific parties will provide the CO or their designee an inventory of hazardous material indicating all materials have been used or removed from the vessel. The CO's designee will maintain a log to track scientific party hazardous materials. MSDS will be made available to the ship's complement, in compliance with Hazard Communication Laws.

Scientific parties are expected to manage and respond to spills of scientific hazardous materials. Overboard discharge of scientific chemicals is not permitted during projects aboard NOAA ships.

D. Radioactive Isotopes

No Radioactive Isotopes are planned for this project.

E. Inventory (itemized) of Radioactive Materials
N/A

V. Additional Projects

A. Supplementary ("Piggyback") Projects:
No Supplementary Projects are planned.

B. NOAA Fleet Ancillary Projects:
No NOAA Fleet Ancillary Projects are planned.

VI. Disposition of Data and Reports

Disposition of data gathered aboard NOAA ships will conform to NAO 216-101 *Ocean Data Acquisitions* and NAO 212-15 *Management of Environmental Data and Information*. To guide the implementation of these NAOs, NOAA's Environmental Data Management Committee (EDMC) provides the *NOAA Data Documentation Procedural Directive* (data documentation) and *NOAA Data Management Planning Procedural Directive* (preparation of Data Management Plans). OMAO is developing procedures and allocating resources to manage OMAO data and Programs are encouraged to do the same for their Project data.

A. Data Classifications: *Under Development*

- a. OMAO Data
- b. Program Data

B. Responsibilities: *Under Development*

VII. Meetings, Vessel Familiarization, and Project Evaluations

- A. Pre-Project Meeting: The Chief Scientist and Commanding Officer will conduct a meeting of pertinent members of the scientific party and ship's crew to discuss required equipment, planned operations, concerns, and establish mitigation strategies for all concerns. This meeting shall be conducted before the beginning of the project with sufficient time to allow for preparation of the ship and project personnel. The ship's Operations Officer usually is delegated to assist the Chief Scientist in arranging this meeting.
- B. Vessel Familiarization Meeting: The Commanding Officer is responsible for ensuring scientific personnel are familiarized with applicable sections of the standing orders and vessel protocols, e.g., meals, watches, etiquette, drills, etc. A vessel familiarization meeting shall be conducted in the first 24 hours of the project's start and is normally presented by the ship's Operations Officer.
- C. Post-Project Meeting: The Commanding Officer is responsible for conducted a meeting no earlier than 24 hrs before or 7 days after the completion of a project to discuss the overall success and short comings of the project. Concerns regarding safety, efficiency, and suggestions for future improvements shall be discussed and mitigations for future projects will be documented for future use. This meeting shall be attended by the ship's officers, applicable crew, the Chief Scientist, and members of the scientific party and is normally arranged by the Operations Officer and Chief Scientist.
- D. Project Evaluation Report

Within seven days of the completion of the project, a Customer Satisfaction Survey is to be completed by the Chief Scientist. The form is available at <http://www.oma.noaa.gov/fleeteval.html> and provides a "Submit" button at the end of the form. Submitted form data is deposited into a spreadsheet used by OMAO management to analyze the information. Though the complete form is not shared with the ships', specific concerns and praises are followed up on while not divulging the identity of the evaluator.

VII. Miscellaneous

A. Meals and Berthing

The ship will provide meals for the scientists listed above. Meals will be served 3 times daily beginning one hour before scheduled departure, extending throughout the project, and ending two hours after the termination of the project. Since the watch schedule is split between day and night, the night watch may often miss daytime meals and will require adequate food and beverages (for example a variety of sandwich items, cheeses, fruit, milk, juices) during what are not typically meal hours. Special dietary requirements for scientific participants will be made available to the ship's command at least seven days prior to the survey.

Berthing requirements, including number and gender of the scientific party, will be provided to the ship by the Chief Scientist. The Chief Scientist and Commanding Officer will work together on a detailed berthing plan to accommodate the gender mix of the scientific party taking into consideration the current make-up of the ship's complement. The Chief Scientist is responsible for ensuring the scientific berthing spaces are left in the condition in which they were received; for stripping bedding and linen return; and for the return of any room keys which were issued. The Chief Scientist is also responsible for the cleanliness of the laboratory spaces and the storage areas utilized by the scientific party, both during the project and at its conclusion prior to departing the ship.

All NOAA scientists will have proper travel orders when assigned to any NOAA ship. The Chief Scientist will ensure that all non NOAA or non Federal scientists aboard also have proper orders. It is the responsibility of the Chief Scientist to ensure that the entire scientific party has a mechanism in place to provide lodging and food and to be reimbursed for these costs in the event that the ship becomes uninhabitable and/or the galley is closed during any part of the scheduled project.

All persons boarding NOAA vessels give implied consent to comply with all safety and security policies and regulations which are administered by the Commanding Officer. All spaces and equipment on the vessel are subject to inspection or search at any time. All personnel must comply with OMAO's Drug and Alcohol Policy dated May 7, 1999 which forbids the possession and/or use of illegal drugs and alcohol aboard NOAA Vessels.

B. Medical Forms and Emergency Contacts

The NOAA Health Services Questionnaire (NHSQ, NF 57-10-01 (3-14)) must be completed in advance by each participating scientist. The NHSQ can be obtained from the Chief Scientist or the NOAA website <http://www.corporateservices.noaa.gov/noaaforms/eforms/nf57-10-01.pdf>.

All NHSQs submitted after March 1, 2014 must be accompanied by NOAA Form (NF) 57-10-02 - Tuberculosis Screening Document in compliance with OMAO Policy 1008 (Tuberculosis Protection Program).

The completed forms should be sent to the Regional Director of Health Services at the applicable Marine Operations Center. The NHSQ and Tuberculosis Screening Document should reach the Health Services Office no later than 4 weeks prior to the start of the project to allow time for the participant to obtain and submit additional information should health services require it, before clearance to sail can be granted. Please contact MOC Health Services with any questions regarding eligibility or completion of either form. Ensure to fully complete each form and indicate the ship or ships the participant will be sailing on. The participant will receive an email notice when medically cleared to sail if a legible email address is provided on the NHSQ.

The participant can mail, fax, or email the forms to the contact information below. Participants should take precautions to protect their Personally Identifiable Information (PII) and medical information and ensure all correspondence adheres to DOC guidance (http://ocio.os.doc.gov/ITPolicyandPrograms/IT_Privacy/PROD01_008240).

The only secure email process approved by NOAA is Accellion Secure File Transfer which requires the sender to setup an account. Accellion's Web Users Guide is a valuable aid in using this service, however to reduce cost the DOC contract doesn't provide for automatically issuing full functioning accounts. To receive access to a "Send Tab", after your Accellion account has been established send an email from the associated email account to accellionAlerts@doc.gov requesting access to the "Send Tab" function. They will notify you via email usually within 1 business day of your approval. The "Send Tab" function will be accessible for 30 days.

Contact information:

Regional Director of Health Services
Marine Operations Center – Pacific

2002 SE Marine Science Dr.
Newport, OR 97365
Telephone 541-867-8822
Fax 541-867-8856
Email MOP.Health-Services@noaa.gov

Prior to departure, the Chief Scientist must provide an electronic listing of emergency contacts to the Executive Officer for all members of the scientific party, with the following information: contact name, address, relationship to member, and telephone number.

C. Shipboard Safety

Hard hats are required when working with suspended loads. Work vests are required when working near open railings and during small boat launch and recovery operations. Hard hats and work vests will be provided by the ship when required.

Wearing open-toed footwear or shoes that do not completely enclose the foot (such as sandals or clogs) outside of private berthing areas is not permitted. Steel-toed shoes are required to participate in any work dealing with suspended loads, including CTD deployments and recovery. The ship does not provide steel-toed boots. The ship's Operations Officer should be consulted by the Chief Scientist to ensure members of the scientific party report aboard with the proper attire.

D. Communications

A progress report on operations prepared by the Chief Scientist may be relayed to the program office. Sometimes it is necessary for the Chief Scientist to communicate with another vessel, aircraft, or shore facility. Through various means of communications, the ship can usually accommodate the Chief Scientist. Special radio voice communications requirements should be listed in the project instructions. The ship's primary means of communication with the Marine Operations Center is via e-mail and the Very Small Aperture Terminal (VSAT) link. Standard VSAT bandwidth at 128kbs is shared by all vessels staff and the science team at no charge. Increased bandwidth in 30 day increments is available on the VSAT systems at increased cost to the scientific party. If increased bandwidth is being considered, program accounting is required it must be arranged at least 30 days in advance.

E. IT Security

Any computer that will be hooked into the ship's network must comply with the *OMAO Fleet IT Security Policy* 1.1 (November 4, 2005) prior to establishing a direct connection to the NOAA WAN. Requirements include, but are not limited to:

- (1) Installation of the latest virus definition (.DAT) file on all systems and performance of a virus scan on each system.
- (2) Installation of the latest critical operating system security patches.
- (3) No external public Internet Service Provider (ISP) connections.

Completion of these requirements prior to boarding the ship is required.

Non-NOAA personnel using the ship's computers or connecting their own computers to the ship's network must complete NOAA's IT Security Awareness Course within 3 days of embarking.

F. Foreign National Guests Access to OMAO Facilities and Platforms

Foreign National access to the NOAA ship or Federal Facilities is not required for this project.

VIII. Appendices**1. Station list**

	Sta Name	Activity	Water Depth (m)	lon.dd	lat.dd
	Depart Dutch Harbor	DEPART		166.432	53.881
				165.667	54.333
UP mooring	14UP-3A	Deploy	83	164.743	54.302
	UP-3A	CTD	83	164.743	54.302
		Deploy drifter		164.743	54.302
Unimak Box	UBS1	CTD/BON	42	164.985	54.441
	UBS2	CTD/BON	110	165.141	54.419
	UBS3	CTD	203	165.277	54.375
	UBS4	CTD/BON	91	165.429	54.342
	UBW1	CTD/BON	91	165.929	54.358
	UBW2	CTD/BON	511	166.039	54.472
	UBW3	CTD	402	166.129	54.583
	UBW4	CTD/BON	329	166.237	54.688
	UBN1	CTD/BON	183	166.051	54.751
	UBN2	CTD/BON	168	165.858	54.813
	UBN3	CTD	153	165.671	54.868
	UBN4	CTD/BON	139	165.480	54.930
	UBN5	CTD	124	165.287	54.987
	UBN6	CTD/BON	110	165.107	55.049
	UBE1	CTD/BON	88	164.996	54.937
	UBE2	CTD	67	164.894	54.827
	UBE3	CTD/BON	46	164.784	54.716

Unimak Box mooring	14UBP-1A	Deploy	88	164.996	54.937
BS Site 2	14BSM-2A	Deploy	72	164.050	56.867
	14BSP-2A	Deploy	72	164.050	56.867
	70M2/M2	3 CalVETs	72	164.053	56.900
	70M2/M2	CTD/BON	72	164.053	56.900
	CTD -M2N	CTD/BON	69	164.217	57.017
	CTD - M2E	CTD/BON	69	163.834	56.942
	CTD -M2S	CTD/BON	72	163.867	56.667
	CTD - M2W	CTD/BON	75	164.333	56.767
70 m isobath	70M3	CTD	68	164.583	56.808
	70M4	CTD/BON	67	164.828	56.909
	70M5	CTD	68	165.123	56.859
	70M6	CTD/BON	67	165.378	56.994
	70M7	CTD	65	165.613	57.107
	70M8	CTD/BON	65	165.747	57.262
	70M9	CTD	65	166.011	57.321
	70M10	CTD/BON	65	166.326	57.322
	70M11	CTD	65	166.513	57.438
	70M12	CTD/BON	65	166.812	57.429
	70M13	CTD	65	167.038	57.522
	70M14	CTD/BON	66	167.344	57.499
	70M15	CTD	67	167.665	57.501
	70M16	CTD/BON	66	167.986	57.501
	70M17	CTD	74	168.304	57.520
	70M18	CTD/BON	73	168.614	57.524
	70m19- M4S	CTD/BON	65	169.020	57.653

	CTD - M4E	CTD/BON	64	168.467	57.767
	70M21/M4	3 CaIVETs	72	168.887	57.833
	70M21/M4	CTD/BON	67	168.887	57.833
	70m22 - M4W	CTD/BON	71	169.322	57.927
	CTD - M4N	CTD/BON	71	168.730	58.067
	70M23	CTD	65	169.500	57.907
	70M24	CTD/BON	64	169.673	58.042
	70M25	CTD	66	169.918	58.147
	70M26	CTD/BON	67	170.095	58.282
	70M27	CTD	68	170.186	58.446
	70M28	CTD/BON	67	170.276	58.617
	70M29	CTD	66	170.294	58.774
	70M30	CTD/BON	67	170.327	58.948
	70M31	CTD	64	170.247	59.107
	70M32	CTD/BON	63	170.412	59.247
	70M33	CTD	65	170.656	59.335
	70M34	CTD/BON	81	170.906	59.436
	70M35	CTD	80	170.923	59.595
	70M36	CTD/BON	79	171.140	59.716
	70M37	CTD/BON	78	171.450	59.777
	M5E	CTD/BON	70	171.258	59.898
	CTD - M5S	CTD/BON	70	171.500	59.700
	70m38/ M5	3 CaIVETs	70	171.711	59.892
	70m38/ M5	CTD/BON	70	171.711	59.892
	70M38 - M5N	CTD/BON	70	172.000	60.075
	70M39 M5W	CTD/BON	70	172.167	59.898

L-Line		CTD	200	168.199	55.380
L-Line		CTD	1000	168.525	55.170
L-Line		CTD	300	168.899	54.950
L-Line		CTD	985	169.337	54.690
L-Line	DL7/LL8	CTD	1900	169.833	54.350
L-Line	DL6/LL9	CTD	1850	169.560	54.037
L-Line	DL5/LL10	CTD	1575	169.267	53.783
L-Line	DL4/LL11	CTD	1800	169.035	53.610
L-Line	DL3/LL12	CTD	1500	168.903	53.520
L-Line	DL2	CTD	340	168.793	53.440
L-Line	DL1/LL15	CTD	340	168.692	53.368
Deploy BS6 mooring	14BSP-6A	Deploy 14BSP-6A	1000	168.854	53.406
	14BSP-6A	Deploy drifter		168.854	53.406
Deploy BC mooring	14ULP-1A	Deploy 14ULP-1A	1000	167.074	54.073
	14ULP-1A	Deploy drifter		167.074	54.073
Bering Canyon Transects	UT5	CTD/MNET	100	166.970	53.970
	UT4	CTD	1300	167.067	54.085
	UT3	CTD/MNET	1700	167.150	54.175
	UT2	CTD	1100	167.267	54.322
	UT1	CTD/MNET	650	167.380	54.452
	AW5	CTD/MNET	550	166.938	54.458
	AW4	CTD	750	166.818	54.320
	AW3	CTD/MNET	1350	166.710	54.205
	AW2	CTD	900	166.652	54.140
		Deploy		166.652	54.140

		drifter			
	AW1	CTD/MNET	100	166.620	54.072
	AE1	CTD/MNET	90	166.233	54.168
	AE2	CTD	700	166.263	54.233
	AE3	CTD/MNET	900	166.350	54.305
	AE4	CTD	550	166.480	54.437
	AE5	CTD/MNET	450	166.593	54.562
	UBW4	CTD/MNET	82	166.237	54.688
	UBW3	CTD	81	166.129	54.583
	UBW2	CTD/MNET	80	166.039	54.472
	UBW1	CTD	79	165.929	54.358
	UBW0	CTD/MNET	50	165.883	54.310
	Arrive Dutch Harbor	ARRIVE	650	166.432	53.881

2. Multi-net



MultiNet[®]

Multi Plankton Sampler



Features:

- Combined online/offline use (standard)
- Bi-directional communication
- Standard depth range 3000 m
- Long distance FSK-telemetry (> 10000m)
- Low power consumption
- Battery operated Underwater Unit, max. voltage of 5 V at the conductor cable
- Electronics operate from -40°C up to +85°
- EC-conformity (CE) EN 50081-1, EN 50082-1
- expandable range of sensors

phone: +49-431-36960-0 fax: +49-431-36960-21 e-mail:
info@hydrobios.de web: www.hydrobios.de

The System

Sampling sea and ocean at its best - with the improved MultiNet[®] generation of the Multiple Plankton Sampler, the worlds leading sampling system for horizontal and vertical collections in successive water layers.

New: for combined online/offline use

Equipped with 5 resp. 9 net bags the MultiNet[®] can be delivered in 4 sizes (apertures) : Mini (0.125 m²), Midi (0.25 m²), Maxi (0.5 m²) and Mammoth (1 m²).

The system consists of a mains powered Deck Command Unit and a stainless steel frame with canvas part to which 5 (9) net bags are attached by means of zip fasteners. The net bags are opened and closed by means of an arrangement of levers which are triggered by a battery powered Motor Unit. The commands for actuation of the net bags are given via single or multi-conductor cable (not included in our scope of delivery) between the Underwater Unit and the Deck Command Unit.

A wide selection of mesh sizes for the net bags is available to meet the requirements of all standard and non-standard applications. For common horizontal collections a mesh size of 300 microns (mesh sizes from 100 to 500 microns available) is recommended, for vertical collections mesh sizes from 55 to 500 micron are applicable.

An integrated Pressure Sensor (measuring range according to customer's requirements) allows continuous supervision of the actual operating depth which is indicated together with all relevant system data at the LCD-display of the Deck Command Unit.

Two Electronic Flow Meters with automatic angle compensation are mounted to the Underwater Unit: one inside the opening of the Underwater Unit for the determination of the amount of water passing through the opened nets, one outside the opening for the determination of clogging effects.

For horizontal collections the MultiNet[®] is used with a V-Fin Depth Depressor, to carry out vertical collections, a stainless steel support is securely attached to the bucket holder and enables a quick lowering to depth.

Operation

In its initial position the MultiNet[®] is brought to water with all net bags closed. The water flows freely through the frame allowing to lower it to the greatest desired depth with high paying out speed where the first net bag is opened by push button control from the Deck Command Unit. At the end of the desired period of horizontal collection resp. after passing the desired depth interval in case of vertical operation, the first net bag is closed by a second command. The second net is opened simultaneously. This procedure is repeated for the remaining net bags, while the Deck Command Unit indicates the number of the active net bag. During operations of Mini and Midi versions the last net (no. 5) remains open, it collects plankton



from the smallest desired depth up to the water surface. During operations of the Maxi and Mammoth versions the last net (no. 9) can be closed before reaching the water surface.

The Specialties

Offline Use

In case that a conducting cable is not available on board of the vessel, the required sampling depth can be pre-programmed via personal computer. During offline use the activation of the net bags is carried out automatically according to the pre-selected depth intervals. All measuring data are stored inside the internal data memory of 16 MByte during the operation and can be read by a PC when the MultiNet[®] is back on board.

Options

CT-Set

Together with the optional CT-Set the system offers the full capability of a state-of-the-art oceanographic Multi Parameter Probe. The CT-Set consists of one conductivity sensor, one temperature sensor and an additional electronics board which are completely integrated into the Motor Unit of the MultiNet[®]. From the CTD data the system computes salinity, density and sound velocity according to UNESCO formulas.

CT-Set for

MultiNet[®]

Conductivity sensor: 0 ... 65 ± 0.01 mS/cm,
 Temperature sensor: -2 ... $+32 \pm 0.005$ °C
 Data rate : 1 Hz (1 data set per second)

No. 450 500

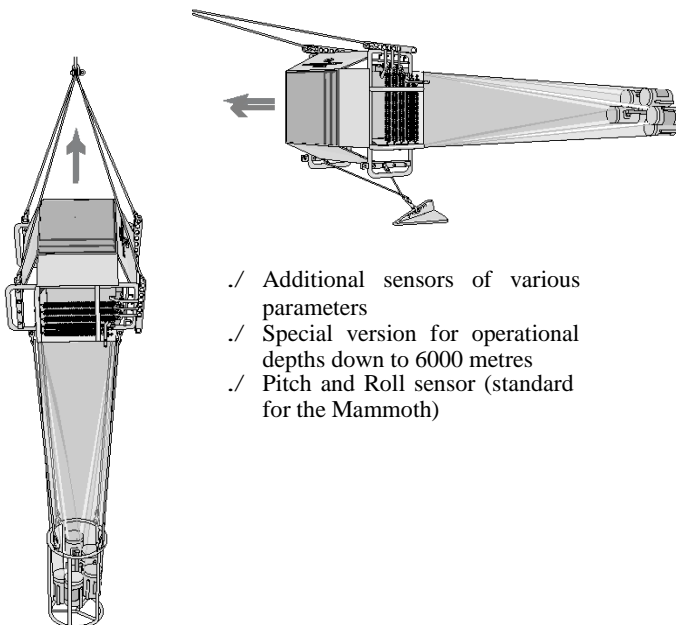

- ./ Additional sensors of various parameters
- ./ Special version for operational depths down to 6000 metres
- ./ Pitch and Roll sensor (standard for the Mammoth)

Technical Data

Underwater Unit:	Type Mini No. 438 120	Type Midi No. 438 130	Type Maxi No. 438 140	Type Mammoth No. 438 180
Dimensions (w x l x h):	65 cm x 90 cm x 80 cm	80 cm x 90 cm x 95 cm	120 cm x 110 cm x 135 cm	150 cm x 120 cm x 160 cm
Net opening:	35.5 cm x 35.5 cm = 0.125 m ²	50 cm x 50 cm = 0.25 m ²	71 cm x 71 cm = 0.5 m ²	100 cm x 100 cm = 1 m ²
Net Bags:	5 pcs., length: 160 cm	5 pcs., length: 250 cm	9 pcs., length: 365 cm	9 pcs., length: 550 cm
Standard mesh size:	300 microns	300 microns	300 microns	300 microns
Net Buckets:	5 pcs., 11 cm dia.	5 pcs., 11 cm dia.	9 pcs., 11 cm dia.	9 pcs., 11 cm dia.
	5 pcs. Soft Net Bucket	5 pcs. Soft Net Bucket	9 pcs. Soft Net Bucket	9 pcs. Soft Net Bucket
Weights:				
Net Frame:	approx. 75 kg	approx. 100 kg	approx. 260 kg	approx. 390 kg
Stainless Steel Support:	approx. 30 kg	approx. 50 kg	approx. 70 kg	approx. 100 kg
V-Fin Depth Depressor:	approx. 22 kg	approx. 22 kg	approx. 70 kg	approx. 70 kg
Overall length ready for operation (from bridle to net bucket):	470 cm	560 cm	800 cm	1000 cm
Materials:				
Net frame:	Stainless Steel	Stainless Steel	Stainless Steel	Stainless Steel
Motor Unit and Battery Housing:	Titanium	Titanium	Titanium	Titanium
Net Bags:	Polyamide	Polyamide	Polyamide	Polyamide
Net Buckets:	PVC/ Canvas	PVC/ Canvas	PVC/ Canvas	PVC/ Canvas
V-Fin Depth Depressor:	Aluminium, lead-weighted	Aluminium, lead-weighted	Aluminium, lead-weighted	Aluminium, lead-weighted
Operational Depth:	Standard 3000 metres	Standard 3000 metres	Standard 3000 metres	Standard 3000 metres
Pressure Sensor:	Standard 3000.0 dbar ± 0.1% f.s. (other ranges on request)	Standard 3000.0 dbar ± 0.1% f.s. (other ranges on request)	Standard 3000.0 dbar ± 0.1% f.s. (other ranges on request)	Standard 3000.0 dbar ± 0.1% f.s. (other ranges on request)
Connection Plug:	SUBCONN BH 2 M	SUBCONN BH 2 M	SUBCONN BH 2 M	SUBCONN BH 2 M
Cable Counter Plug:	SUBCONN IL 2 F	SUBCONN IL 2 F	SUBCONN IL 2 F	SUBCONN IL 2 F
Cable connection:	Single- or multi-conductor cable, one pole can be in contact with sea water			
Breaking load: for shallow water applications (up to 500 m):	approx. 1500 kg	approx. 2000 kg	approx. 4000 kg	approx. 8000 kg
for deep sea applications (from 500 m up to 3000 m):	approx. 5000 kg	approx. 8000 kg	approx. 12000 kg	approx. 18000 kg
Max. cable resistance (go-and-return line):	1000 Ohms	1000 Ohms	1000 Ohms	1000 Ohms
Deck Command Unit:	Metal housing for use in 19" rack or as table housing, not for use on deck; push button control for net changing; indication of net number, pressure, battery status, ... Supertwist LCD-display with LED backlight; Interface for Personal Computer (RS 232)			
Power Supply:				
Underwater Unit:		3 Lithium Batteries DL 123 A/3V, sufficient for approx. 100 hours operation		
Deck Command Unit:	85 - 260 VAC	85 - 260 VAC	85 - 260 VAC	85 - 260 VAC
Towing Speed:				
Recommended for nets with 300 microns standard mesh size:				
Horizontal Collections:	max. 4 knots	max. 4 knots	max. 4 knots	max. 4 knots
Vertical Collections:	max. 1 m per sec.	max. 1 m per sec.	max. 1 m per sec.	max. 1 m per sec.
	The single- or multi-conductor cable is not included in our scope of delivery.			