

Captive Rearing of Fire Shrimp (*Lysmata debelius*)

BY MATTHEW R. PALMTAG AND G.J.HOLT

Fire shrimp (Lysmata debelius) are a popular species in the marine aquarium trade. Wild collection of marine ornamental fishes and invertebrates, such as the fire shrimp, contribute to the pressures on natural populations of coral reef animals. The development of captive culture techniques would help safeguard coral reefs and is essential for the expansion of marine ornamental aquaculture technology. This paper presents a complete and descriptive protocol for the captive culture of fire shrimp. Larvae were fed rotifers (Brachionus plicatilis) and brine shrimp nauplii (Artemia sp.) both enriched with algae (Nannochloris oculata) for the first 12 days. From day 12 post hatch to metamorphosis, larvae received 0.5g of frozen, pureed shrimp and squid in addition to brine shrimp nauplii enriched with algae. We raised 168 shrimp that metamorphosed into juveniles between 75 and 158 days post hatching. All shrimp that metamorphosed into juveniles provided healthy individuals suitable for the marine aquarium trade.

Introduction

Ornamental fish and invertebrate collections on coral reefs contribute to coral reef habitat destruction and degradation of wild populations. Cyanide fishing for food fish and ornamentals is reported to damage coral reefs, and is practiced in at least 15 countries (McManus et al 1997; UNEP/IUCN 1988). Captive cultivation of marine ornamental organisms is a possible “environmentally friendly” solution to supplying the growing aquarium hobby with coral reef organisms. While many fishes and invertebrates sold in the freshwater aquarium industry are cultured in captivity, more complex requirements of marine ornamental organisms have impeded the development of marine ornamental aquaculture technology. Development of this technology requires advancements in captive rearing protocols. We developed a protocol for the captive rearing of fire shrimp (Figure 1) because information is limited, it is a popular organism in the aquarium hobby, and it demands a substantial price, which could benefit the growth of marine ornamental aquaculture technology.

Fletcher et al. (1995) published the only information pertaining to the captive rearing of this species. They provided information about rearing the fire shrimp in captivity, however they did not provide a detailed protocol. The purpose of this work is to provide the details of a protocol we used for rearing fire shrimp in captivity. The methods used in this paper are an enhancement of culture techniques used to rear peppermint shrimp (*Lysmata wurdemanni*, Riley 1994). With this protocol we raised 168

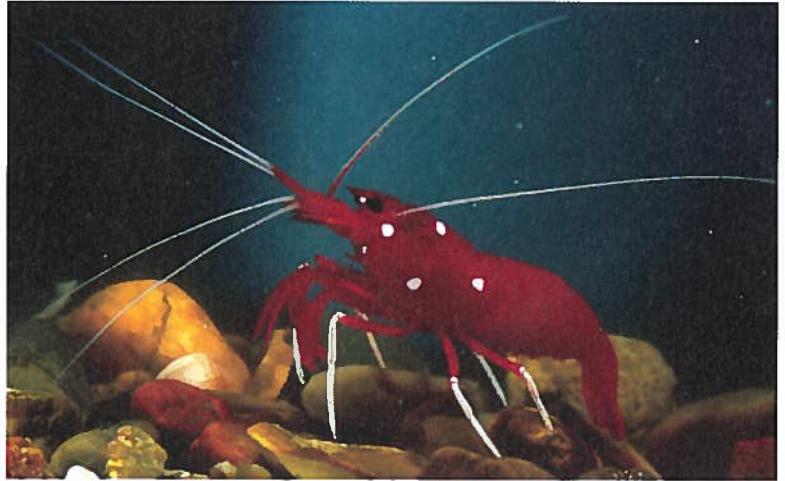

Fig. 1. Adult fire shrimp (*Lysmata debelius*)

shrimp that metamorphosed into juveniles between 75 and 158 days post hatching. All shrimp that metamorphosed into juveniles were healthy and suitable for the marine aquarium trade. Techniques described in this paper lay the ground work for future research and development on the production of fire shrimp, possibly contributing to the preservation of marine ornamental organisms and coral reefs.

Reproductive Biology

Unlike the majority of decapod crustaceans, fire shrimp are simultaneous hermaphrodites (Fletcher et al. 1995), meaning an individual can simultaneously function as a male and female. Similar findings were reported for a closely related species, the peppermint shrimp (Bauer and Holt 1998).

Broodstock Tank

Broodstock are kept in 76- to 114-L (20- to 30-gallon) aquariums with standard undergravel filtration, shell hash substrate, and small rocks arranged to imitate natural reef habitat. Mated pairs become territorial and need to be separated from other fire shrimp to prevent aggression that may result in maiming or death. In our experience, aggression between the individuals of a mated pair does not occur, however, aggression is common when three or more fire shrimp are together. Physical parameters for the successful breeding of fire shrimp are as follows: temperature 25° to 28°C (77° to 82°F), salinity 33 to 37 ppt, photoperiod 12 hr light:12 hr dark, and pH 8.0 to 8.2. Under these conditions, fire shrimp in our laboratory have produced 500 to 3,500 eggs every 10 to 20 days.



Fig. 2. Adult fire shrimp carrying eggs



Fig. 3. Hatching chamber within the rearing chamber

Relocation of Broodstock

Spawning of fire shrimp can be achieved in the broodstock tank, however air stones, under gravel filtration, and changing tank environments often result in high larval mortality. For successful captive cultivation, brooding fire shrimp should be removed from the tank and placed in a hatching/rearing chamber in a larval rearing system (described later) 9 to 19 days after eggs appear on the swimmerets. Our protocol is to move the brooding fire shrimp into the larval rearing system as close to hatching time as possible, and return the shrimp to the broodstock tank immediately following larval release. Fertilization of new eggs occurs after molting which can take place 0 to 24 hours after larval release.

Recognizing the eggs on the first day of adhesion to the swimmerets is extremely difficult because of bold pigmentation throughout the body of the adult shrimp. The swimmerets of a fire shrimp carrying eggs (Figure 2) will appear darker than the abdominal segments above, in contrast to the lighter color of the swimmerets of a fire shrimp without eggs. Hours before the eggs are ready to hatch the eyes of the larvae inside the egg can be observed; this is an indication that it is time to move the parent.

Care must be taken when relocating brooding shrimp to avoid damaging the eggs. Instead of netting the parent fire shrimp, a 500- to 1000-ml (15- to 30-fl. oz) beaker or jar is placed on the substrate of the tank and the shrimp is chased into it by hand. Once the shrimp is completely in the beaker, the opening is covered by hand and slowly raised out of the tank. The beaker is then placed into the larval hatching chamber within the rearing chamber (Figure 3) and the parent is acclimated over a period of at least 20 minutes in the beaker before it is released into the hatching chamber.

Larval Rearing System

The recirculating larval rearing system consists of a 400-L (105-gallon) round fiberglass tank equipped

with a 100-L (26-gallon) external biofilter (Figure 4). Six 18-L (5-gallon) PVC rearing chambers (Figure 5) with 48-um (0.002-in.) nitex mesh, are placed in the tank. Dimensions of rearing chamber are: 25.4 cm (10 in.) diameter and 46 cm (18 in.) height. Rearing chambers concentrate larvae and food, thus increasing food encounter rates. Rearing chambers also provide shelter for the larvae and decrease the possibility of physical damage from aeration, water exchange and heating elements.

The hatching chamber is a plastic cylinder used to contain the parent in the rearing chamber for hatching and allows removal of the parent, minimizing the chance of accidentally capturing and removing larvae. The cylinder (Figure 3) is made of rigid plastic mesh with 1 x 1 cm (3/8 in. x 3/8 in.) holes, 60 cm (24 in.) in length, and 22 cm (8 3/4 in.) in diameter, fits snug into the rearing chamber. A raised level of 1 x 1 cm (3/8 in. x 3/8 in.) rigid plastic mesh, 22 cm (8 3/4 in.) in diameter, is fastened in with cable ties 15 cm (6 in.) from the surface of the cylinder.

To provide water flow into the hatching and rearing chamber a 15 x 3 cm (6 in. x 12 in.) L-shaped 1-inch PVC standpipe equipped with a 3 cm (1 in.) air stone is used (Figure 6). A hole, 3 cm (1 in.) in diameter, is cut into the hatching chamber 15 cm (6 in.) above the raised level to provide access for the standpipe. The standpipe provides a steady flow of oxygenated water directly to the parent fire shrimp, which will aid in the release of larvae as they hatch off the swimmerets.

A 5cm³ (2in³) rock is placed on the raised level of the rigid plastic mesh to mimic the parent fire shrimp tank living conditions (be sure the rock cannot wobble or fall over onto the broodstock).

Removal of Parent

To remove the parent fire shrimp after the eggs have hatched, lift the hatching chamber until the raised level of the rigid plastic cylinder is approximately 3 cm (1 in.) below the

surface of the water. The parent is again chased into the beaker by hand and both the parent and mesh cylinder removed. This method minimizes the possibility of capturing larvae with the adult.

Larval Rearing

Successfully raising the larvae to juveniles is still in the experimental stage. So far about 10 percent survival through the larval stage has been accomplished using the following techniques.

Physical parameters of the larval rearing tank are as follows: temperature 25° to 28°C (77° to 82°F), salinity 33 to 37 ppt, photoperiod 12 hr light:12 hr dark, and pH 8.0 to 8.2. The larvae were divided equally into six 18 L (5 gallon) rearing chambers (approximately 250 larvae per chamber). Larvae were moved by gradually submerging a 250-ml (8 fl oz) beaker into a mixture of water and larvae, and transferring the larvae to alternate rearing chambers. As the density of larvae was reduced, the volume of water in the rearing chamber was decreased by lifting it up, keeping the water line above the bottom of the rearing chamber. This concentrates the remaining larvae so they can be collected. Larvae were released by submerging the beaker half way through the surface of the water and slowly releasing the water and larvae. The standpipe was added to each rearing chamber after the larvae were divided. Air pressure of the standpipe was set to a low level, enabling larvae to slowly circulate around the rearing chamber. Slow flow velocity, 100 to 400 ml per min. (3.3-13.3 fl oz per min.), allows the larvae to grasp the sides of the enclosure; too much current will sweep them off.

On day 1, each of six rearing chambers were given ~50,000 algae (*Nannochloris oculata*) enriched rotifers (*Brachionus plicatilis*) and ~20,000 algae enriched brine shrimp nauplii (*Artemia* sp.). This concentration of rotifers and brine shrimp nauplii was maintained through day 5 (Note: cysts were removed after

hatching brine shrimp nauplii, and rotifers and brine shrimp nauplii were rinsed prior to release into the larval rearing chamber, using a 48 µm (0.002-in.) nitex mesh sieve). In addition, every day beginning with day 1, 200 ml (6.8 fl oz) of algae (*Nannochloris oculata*) at a concentration of ~20,000,000 cells per ml (0.034 fl oz), was added to each rearing chamber to provide nourishment for surviving rotifers and brine shrimp nauplii. On days 6-11 algae enriched brine shrimp nauplii were maintained at a concentration of ~50,000 per rearing chamber. Dead larvae, uneaten food and waste were removed from each rearing chamber every other day by use of a vinyl siphon tube with an inside diameter of 6.35 mm (5/32 in.). On day 10, larvae in each rearing chamber were removed by beaker and transferred into clean rearing chambers. This was repeated for all rearing chambers every 10 days.

On days 12-158, algae enriched brine shrimp nauplii were fed at a concentration of ~30,000 per rearing chamber along with 0.5 g (0.0175 oz) of frozen food. Frozen food composed of 50 percent squid (*Illex* spp.) and 50 percent shrimp (*Penaeus* spp.) was pureed in a blender and refrozen. Portions of this mixture were thawed each morning and administered to the surface water of the rearing chamber. Beginning on day 14 and every fourth day thereafter 4 mls (0.13 fl oz) of Seachem reef calcium (polygluconate calcium) was added.

Larval Development

Fire shrimp pass through at least 10 larval stages before molting to the postlarval form. Prior to stage 5 the fifth parapodia became flattened and expanded into long paddle shaped structures, which may assist in maintaining position and orientation in the water column (Figure 7). Larvae also use these limbs for capturing food and holding onto solid structures in the water column (Fletcher 1995). After the final molt to the juvenile stage, the compound eyes are located on the head rather than terminally

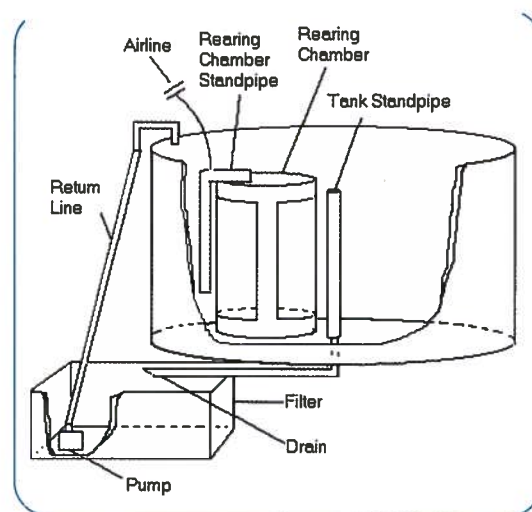

Fig. 4. Recirculating larval rearing system

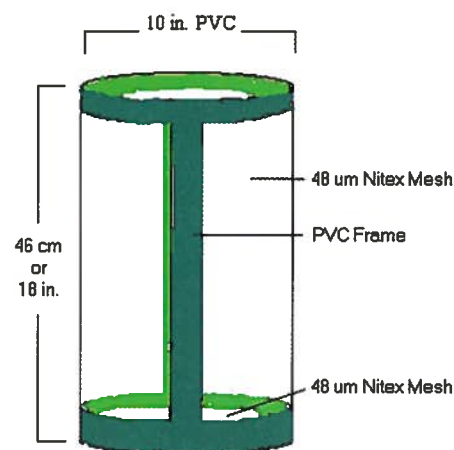

Fig. 5. Rearing chamber

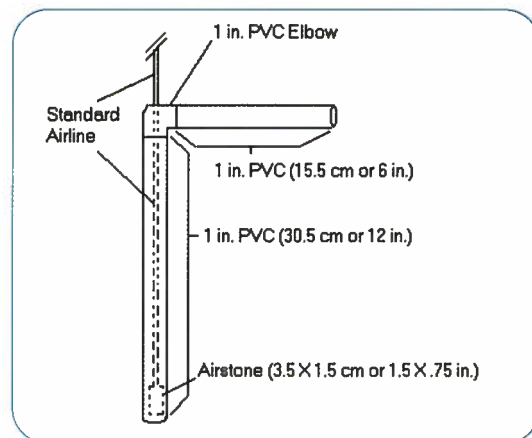

Fig. 6. Stand pipe used in the hatching and rearing chamber

placed on stalks, and the paddle-like appendages become reduced to the typical adult appendages (Figure 8). At this time the shrimp are no longer free swimming but instead settle onto the bottom and sides of the rearing chamber. This benthic transformation may enhance their ability to prey on larger, more diverse foods and increases the animals feeding opportunities (Riley 1994).

Metamorphosis

There were 400 larvae on day 55, when they were counted for the first time. Larvae were not counted earlier for fear that handling stress might increase mortality. The first metamorphosis from a larva into a juvenile occurred on day 75. Previous studies indicate that the larval cycle of fire shrimp lasts for 11 to 15 weeks (77 to 105 days) (Fletcher et al. 1995). Further research on larval nutritional quality may decrease the number of days necessary for metamorphosis to the juvenile stage.

By day 158, 42 percent of the larvae counted on day 55 had metamorphosed into juveniles, the remainder died. We were unable to look at overall mortality and survival, however we estimate that approximately 11 percent of the spawn survived to the juvenile stage. Survival during the juvenile stage was high (approximately 99 percent). Six months from the date of hatching, the juveniles ranged from 30 to 40 mm (1.2 to 1.6 in.) long. At this time they were suitable for sale to marine ornamental retail stores for a price of \$10 each. Even late metamorphosing shrimp provided viable product for the marine aquarium trade.

Summary

The primary objective of this research was to provide a protocol for the captive cultivation of fire shrimp. Protocols such as this are essential for the development of marine ornamental aquaculture technology. This technology may allow aquaculture to provide a form of coral reef habitat preservation and conservation in the near future. Using this protocol we were able to raise 168 adult fire shrimp from a single hatch (estimated hatch 1,500 larvae, 11 percent success rate). Our results suggest that fire shrimp are appropriate subjects for future research and development of marine ornamental aquaculture technology. We in-



Fig. 7. Fire shrimp post-larvae (day 68) with expanded fifth parapodia



Fig. 8. Newly transformed juvenile fire shrimp (day 83)

tend for this information to enable scientists and hobbyists alike to refine this technique or develop better ones, expand research, and provide an alternative to the capture of stressed and endangered wild populations.

Acknowledgements

Cindy Faulk and Charlotte Kucera deserve a special thanks for assistance in every phase of the study and Greg Dimijian for photographing the various life stages of the fire shrimp. We would also like to express gratitude to the people and organizations that ultimately made this work possible with their financial assistance: Hugh A. McAllister, Jr., Charitable Foundation, The World Wildlife Fund, and Texas Sea Grant College Program.

Literature Cited

- Bauer, R.T.; and Holt, G.J. (1998). Simultaneous hermaphroditism in the marine shrimp *Lysmata wurdemanni* (Caridea: Hippolytidae): an undescribed sexual system in the decapod Crustacea. *Marine Biology*, 132: 223-235.
- Fletcher, D.J.; Kotter, I., Wunsch, M. and Yasir, I. (1995). Preliminary observations on the reproductive biology of ornamental cleaner prawns. *Int. Zoo. Yb.*, 34, 73-77.
- Haywood, Martyn; and Wells, Sue. (1989). *The manual of marine invertebrates*. Salamander Books Ltd., Morris Plains, NJ.
- McManus, J.W., Reyes, R. B. Jr., and Nanola, C.L. (1997). Effects of Some Destructive Fishing Methods on Coral Cover and Potential Rate of Recovery. *Environmental Management* Vol. 21, No. 1, pp. 69-78.
- Riley, Cecilia M. (1994). Captive spawning and rearing of the peppermint shrimp (*Lysmata Wurdemanni*). *Sea Scope* Vol. 11.
- Simoes, F.; Yasir I., Jones, D.A. (1998). Reproductive Biology of *Lysmata debelius* (Bruce 1983) and *L. ambionensis* (De Man 1888), (Crustacea, Caridea) Tropical Marine Cleaner Shrimps Important In the Sea Water Aquarium Trade. Abstract, World Aquaculture Society, Las Vegas, 1998, 3 pp.
- UNEP/IUCN. 1988. Coral reefs of the world, 3 vols. UNEP Regional Seas Directories and Bibliographies. IUCN, Gland, Switzerland and Cambridge, UK/UNEP, Nairobi, Kenya.