

CONSTRUCTION AND INSTALLATION INSTRUCTIONS FOR THE TRAWLING EFFICIENCY DEVICE

Revised January 1985

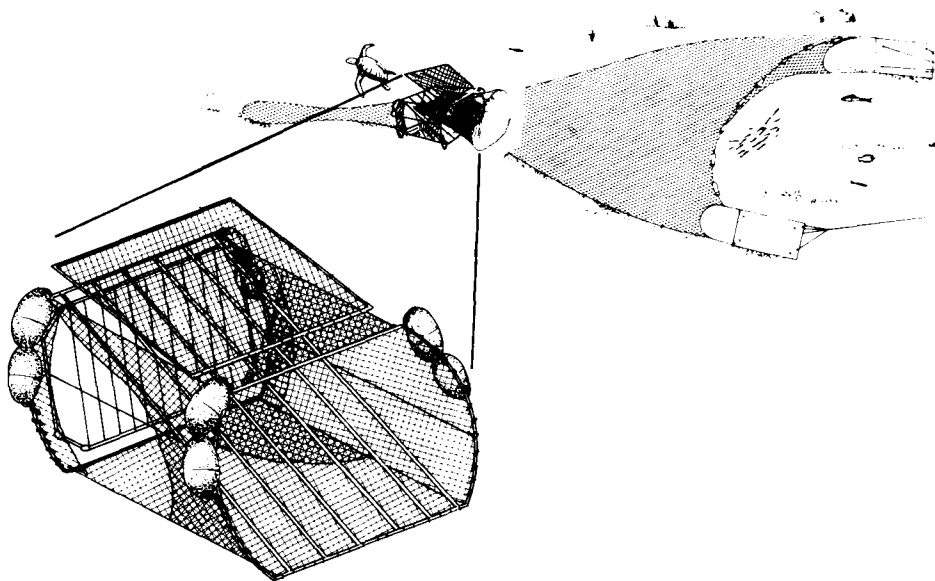

U.S. Department of Commerce
National Oceanic and Atmospheric Administration
National Marine Fisheries Service
Southeast Fisheries Center
Mississippi Laboratories
Pascagoula Facility
P.O. Drawer 1207
Pascagoula, MS 39567-0112

**Construction and Installation Instructions
for the Trawling Efficiency Device**

Charles W. Taylor, Anthony F. Serra
John F. Mitchell, John W. Watson

The Trawling Efficiency Device (TED)

This pamphlet describes a new piece of fishing gear developed by the National Marine Fisheries Service (NMFS) for use by the commercial shrimping industry in the southeastern United States. The gear, called the Trawling Efficiency Device or TED, has been shown to increase trawling efficiency by decreasing bycatch and improving water flow through the trawl. The TED consists of a 36- by 42- by 30-in. frame constructed of 3/8-in. (I.D.) galvanized pipe or 5/8-in. (O.D.) fiberglass rod. Inside the frame are deflector bars slanted at approximately 45° spaced 3 to 6 inches apart with a 30- by 30-in. door at the top of the deflector bars. Objects that cannot pass through the grid bars are forced toward the "trap door." The door opens on hinges, allows the object to pass out of the trawl, and then closes as the object is released. Smaller objects (fish, shrimp, etc.) pass through a webbing funnel which accelerates the water flow and carries them through the slanted bars and into the bag. Deflector bar spacing can be adjusted between 3 and 6 inches to include bycatch such as cannonball jellyfish, horseshoe crabs, sponges, etc. The difference in behavioral responses between shrimp and finfish in the accelerated water flow generated by the funnel is used to separate finfish by employing a smaller finfish deflector grid and openings and leading panels to guide them out of the trawl. Extensive testing has shown that TED effectively reduces the bycatch of cannonball jellyfish, sponges, horseshoe crabs, turtles, sharks, rays and finfish, and as a result improves the efficiency of shrimp trawls by allowing longer towing times with reduced labor in sorting shrimp from the bycatch. Finfish reduction rates exceeding 50% at night and 60% during daytime fishing have been consistently achieved with TED. This pamphlet provides instructions for the construction of both a steel and fiberglass design TED and instructions on the installation of the TED into a trawl.

Construction of Device Frame

NOTE: The device frame can be constructed from either steel pipe or fiberglass rod. The instructions for both materials are listed below.

A. Construction of device frame from steel pipe.

List of Materials:

1. Twenty-nine (29) ft of 3/8-in. (I.D.) galvanized T&C pipe.
2. Thirty-three (33) ft of 1/4-in. (I.D.) galvanized T&C pipe.
3. Six (6) ft of 3/8-in. reinforcement rod.
4. Twenty-four (24) ft 1/8-in. 7 x 19 SS cable.
5. Twelve 1/8-in. nicopress oval sleeves.
6. Six 1/8-in. nicopress stop sleeves.
7. Six 3/16-in. galvanized shackles.
8. One (1) ft of 1/4-in. galvanized chain.

End Frames

1. Cut two (2) 9-ft sections of 3/8-in. galvanized pipe.
2. Mark each of the 9-ft pipe sections in the center, 15 in. on each side of the center, and 51 in. on each side of the center.
3. Bend each of the 9-ft sections of pipe beginning at the 15-in. marks forming two hoops that are 30 in. in height and 6 in. at the center of the radius formed by the bends (see figure 1).
4. Make an additional 90° bend at the 51-in. marks and cut off the excess pipe to form 1-1/2-in. nipples for hinge brackets. The completed hoops should be 30 in. high and 45 in. wide.
5. Cut two (2) links of 1/4 in. chain in half.
6. Mark the center of the sides on each frame and 1/2 in. from the corners on each frame (see figure 1).
7. At these marks weld the half links to the pipe. All half links should be welded to the same side of the pipe and as close to perpendicular as possible.

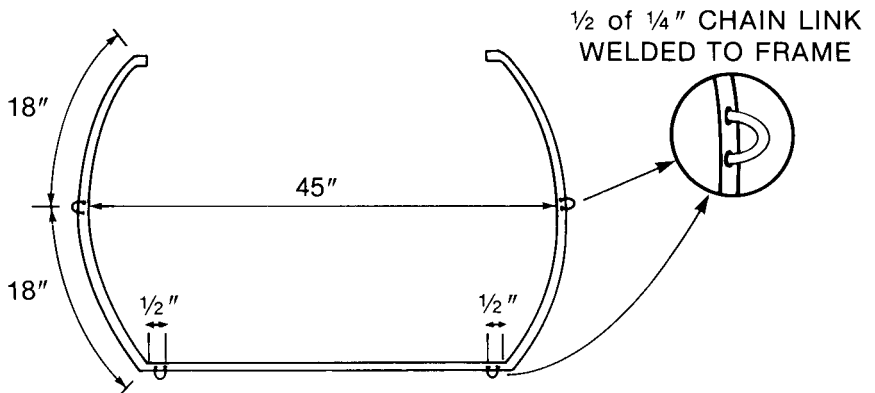
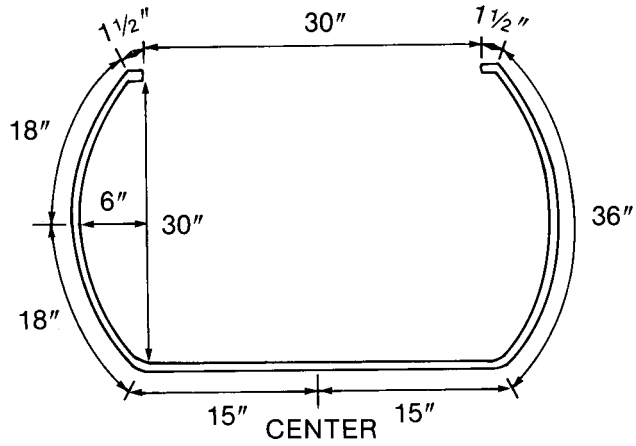
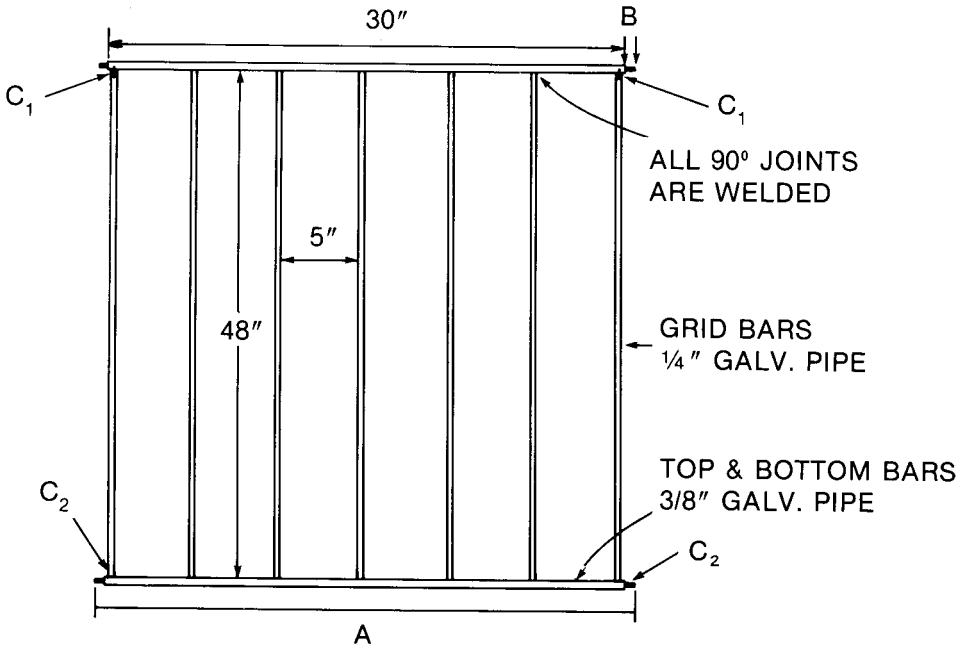

FIGURE 1
 CONSTRUCTION OF END FRAMES

Deflector Grid

1. Cut two (2) 30-in. lengths of 3/8-in. galvanized pipe.
2. Cut seven (7) 48-in. lengths of 1/4-in. galvanized pipe.
3. Cut two (2) 31-1/2-in. lengths of 3/8-in. reinforcement rod.
4. On a flat surface lay out a rectangle of the pre-cut pipe with the sides being 48 in. of 1/4-in. galvanized pipe and the top and bottom being 30 in. of 3/8-in. galvanized pipe (see figure 2).
5. Weld the corners of the rectangle at 90° angles leaving the end openings of the 3/8-in. pipe unobstructed. Insert the 31-1/2-in. of 3/8-in. re-rod sections into the 3/8-in. pipe at the top and bottom of the grid frame. Do not weld the re-rod sections.
6. Mark the top and bottom sections of the grid at 5-in. intervals from the ends of each pipe. A total of five marks should be made.
7. Center the five remaining 48-in. lengths of 1/4-in. pipe on the marks and weld at 90° angles to form the complete grid (see figure 2).
8. Cut two (2) links of 1/4-in. chain in half.
9. At one end of the deflector grid weld one of the half links at each corner (see figure 2). Turn the deflector grid over and repeat the procedure at the opposite end of the deflector.



- A HINGE—A 3 1/2" LENGTH OF 3/8" REINFORCEMENT ROD INSERTED INSIDE BOTH TOP AND BOTTOM BARS
- B 3/4"—REINFORCEMENT ROD OVERHANG
- C₁ POSITION OF WELDED HALF LINKS
- C₂ POSITION OF WELDED HALF LINKS ON OPPOSITE SIDE OF DEFLECTOR

FIGURE 2
CONSTRUCTION OF DEFLECTOR GRID

Door Frame

1. Cut two (2) 30-in. lengths of 3/8-in. galvanized pipe.
2. Cut two (2) 30-in. lengths of 1/4-in. galvanized pipe.
3. On a flat surface lay out the pre-cut pipe to form a square with the 1/4-in. galvanized pipe on opposite sides (see figure 3).
4. Weld corners at 90° angles.

Assembly

1. Connect the grid deflector to the end frames by inserting the 3/4 in. of exposed re-rod at each end of the grid deflector into the 1-1/2-in. nipples on the end frames. The frames and deflector grid should be connected so that when in the upright grid position, the half links are positioned as in figure 4.
2. Weld the re-rod to the end frames at the points indicated in figure 4. The reinforcement rod should not be welded to the deflector grid and should rotate freely inside the top and bottom bars of the grid.
3. Brace cable assembly -
 - a. Cut six (6) 48-in. lengths of 1/8-in. stainless steel cable.
 - b. Brace the device frame in an upright position using three (3) 36-in. sections of 3/8-in. galvanized pipe or other material between the front and back hoop. Secure the braces in place using twine.
 - c. Compress a 1-in. eye into one end of each of the 48-in. lengths of cable using oval nicopress sleeves.
 - d. Shackle six (6) cables to the welded half links on one hoop.
 - e. Slide the nicopress stop sleeve onto each cable.
 - f. Attach the free end of each brace cable to the welded half links on the opposite hoop with a nicopress oval sleeve. Pull out all the slack, then crimp the oval sleeve approximately 1 in. from the welded link. Cut off excess cable.

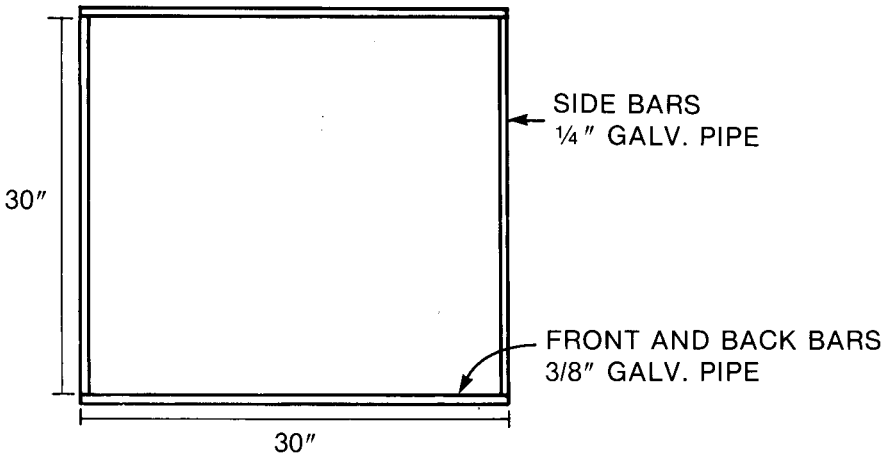

FIGURE 3. CONSTRUCTION OF DOOR FRAME

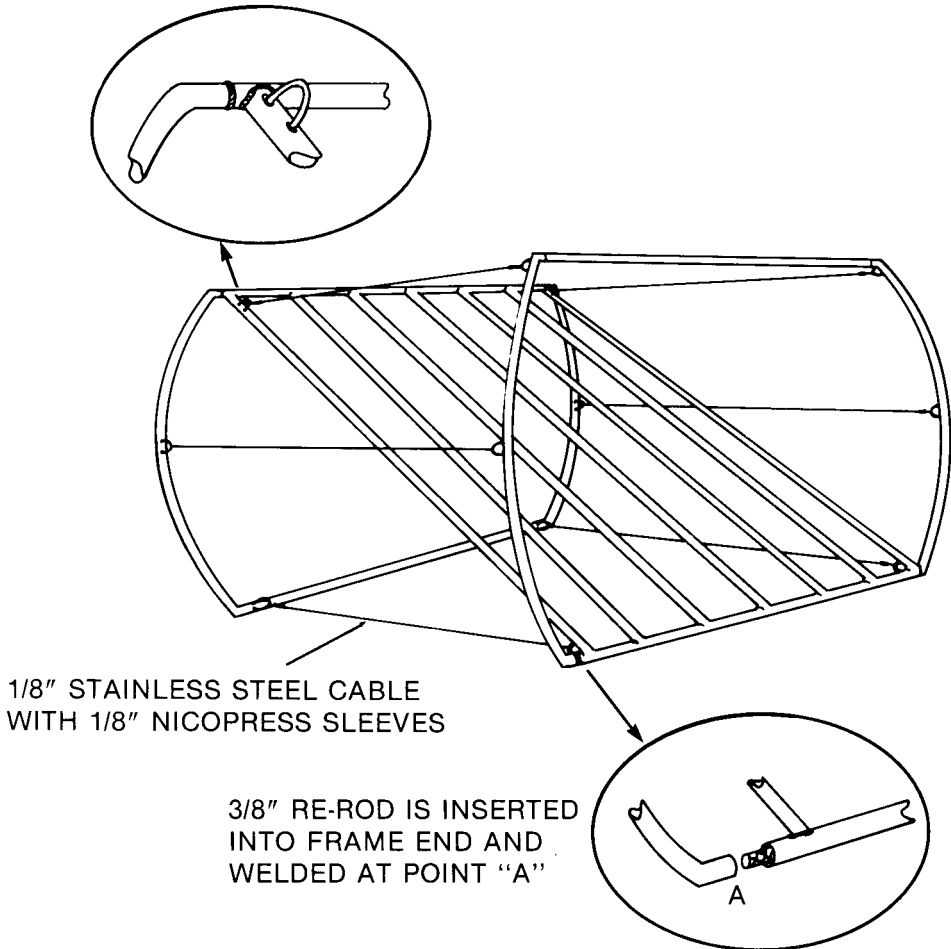

FIGURE 4. COMPLETED STEEL FRAME

B. Construction of device frame from fiberglass rod.

List of Materials:

1. Sixty (60) ft of 5/8-in. fiberglass rod (12-ft sections).
2. Sixteen (16) 3/8-in. galvanized 45° fittings.
3. Twelve (12) 3/8-in. galvanized T fittings.
4. Eight (8) 3/8-in. galvanized couplings.
5. Four (4) 3/8-in. galvanized unions.
6. Four (4) 3/8-in. galvanized 90° fittings.
7. Eight (8) 3/8-in. x 4-in. galvanized nipples.
8. Six (6) ft of 3/32-in. stainless steel rod (3-ft sections).
9. Twenty-four (24) ft of 1/8-in. 7 x 19 stainless steel cable.
10. Twelve (12) 1/8-in. nicopress oval sleeves.
11. Six (6) 1/8-in. nicopress stop sleeves.
12. Eight (8) 3/16-in. galvanized shackles.
13. Two (2) 3-1/2-oz kits of 3M No. 2216 epoxy glue.
14. One (1) 5/8-in. drill bit (measure rod diameter for exact bit size).
15. One (1) 3/32-in. drill bit.
16. Medium sand paper.

**Preparation for Construction of Device Frame
(See Figure 5)**

1. Cut two (2) 34-1/2-in. sections of 5/8-in. fiberglass rod.
2. Cut two (2) 30-1/4-in. sections of 5/8-in. fiberglass rod.
3. Cut four (4) 23-1/2-in. sections of 5/8-in. fiberglass rod.
4. Cut two (2) 30-1/2-in. sections of 5/8-in. fiberglass rod.
5. Cut two (2) 31-1/2-in. sections of 5/8-in. fiberglass rod.
6. Cut two (2) 36-in. sections of 5/8-in. fiberglass rod.
7. Cut six (6) 47-in. sections of 5/8-in. fiberglass rod.
8. Sand one (1) in. of each end of all rods except the 36-in. sections.
9. Drill twelve (12) 45° fittings with 5/8-in. drill bit (one side only).
10. Drill twelve (12) T fittings completely through long side and threads only of perpendicular side.
11. Drill eight (8) couplings completely through.
12. Drill out threads of rotating side of union.
13. Drill four (4) 90° fittings (both sides).
14. Weld back (curved side) of 3/16-in. shackles perpendicular to drilled-out 8 couplings.

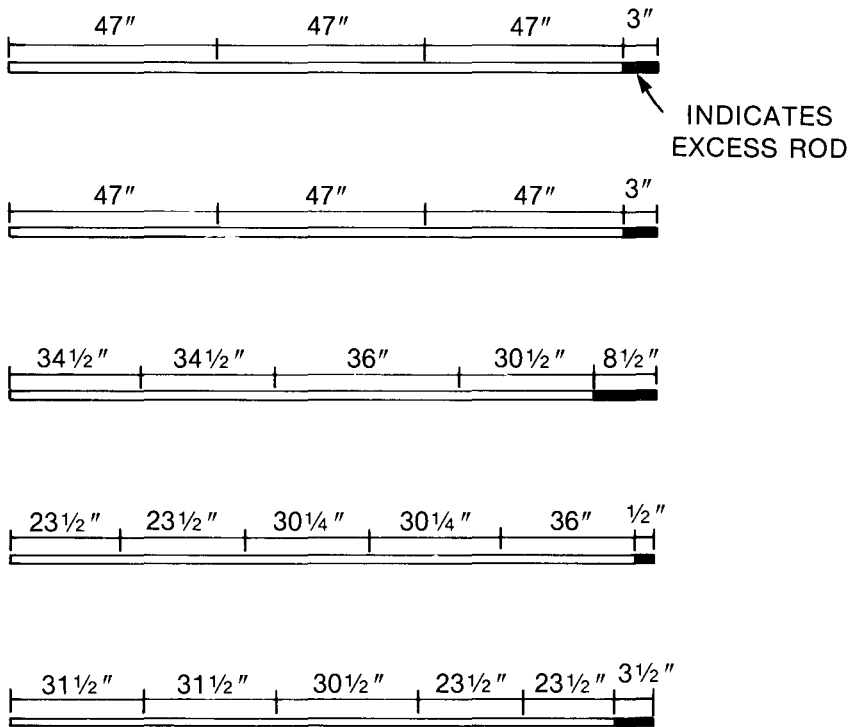

FIGURE 5.
CUTTING LAYOUT FOR 5/8" FIBERGLASS ROD
12 FOOT LENGTHS

Corner and Hinge Assembly (See Figure 6)

1. Weld non-drilled 45° fitting to threaded side of each of the four (4) unions (center as closely as possible).
2. Weld T fittings to rotating side of each union (line up holes as closely as possible).
3. Screw 3/8-in. x 4-in. nipple into each 45° fitting welded to union.
4. Screw drilled 45° fitting onto open end of each 3/8-in. x 4-in. nipple (make sure 45° fittings face the same direction).
5. Screw remaining drilled 45° fittings onto each end of four (4) 3/8-in. x 4-in. nipples (make sure 45° fittings face the same direction).

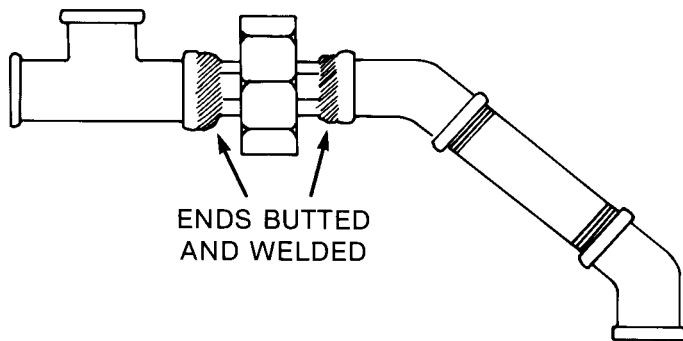
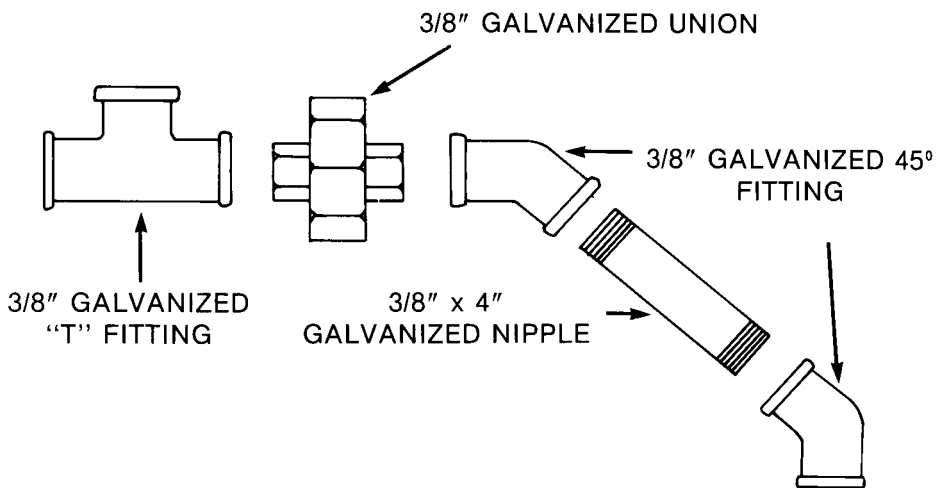

FIGURE 6.
CORNER AND HINGE ASSEMBLY

Assembly of Device Frame (See Figures 7 and 8)

NOTE: Work on a flat surface to assure proper alignment of fittings.

1. Mix glue according to instructions on box.
2. Slide four (4) T fittings onto each of the two (2) 30-1/4-in. sections of rod.
3. Place a moderate amount of glue into each of the T fittings welded to the unions.
4. Insert each end of the two (2) 30-1/2-in. rods into the glued T fittings
5. Slide one (1) coupling onto each 23-1/2-in. section of fiberglass rod.
6. Place a moderate amount of glue into the 45° fittings welded to the unions.
7. Insert one end of each 23-1/2-in. rod into the four (4) glued 45° fittings.
8. Place a moderate amount of glue into one (1) 45° fitting on the remaining four (4) corner assemblies.
9. Slide four (4) glued 45° fittings onto the end of each 23-1/2-in. rod.
10. Place a moderate amount of glue into each of the remaining 45° fittings on the corner pieces.
11. Slide two (2) couplings onto each 34-1/2-in. rod.
12. Insert each end of 34-1/2-in. rods into the glued 45° fittings, completing the two hoops.

Assembly of Grid Bars

1. Space T fittings on each hoop approximately 3-3/8 in. apart (5-1/4-in. centers).
2. Place a moderate amount of glue into the front hole of each T fitting on both hoops.
3. Insert one end of each 47-in. rod into the six (6) T fittings on one hoop; then insert the opposite end of the 47-in. rod into the corresponding T fittings of the second hoop (compression strings may be needed to hold grid bars securely into place).
4. Recheck T fitting spacing, and make sure hoops are square; then allow the glue to dry.

Door Assembly (See Figure 9)

1. Place a moderate amount of glue into both ends each of the four (4) 90° fittings.
2. Insert both 31-1/2-in. and both 30-1/2-in. fiberglass rods into the glued 90° fittings to form a rectangle with opposite sides of equal length. Square corners as closely as possible. Allow to dry.

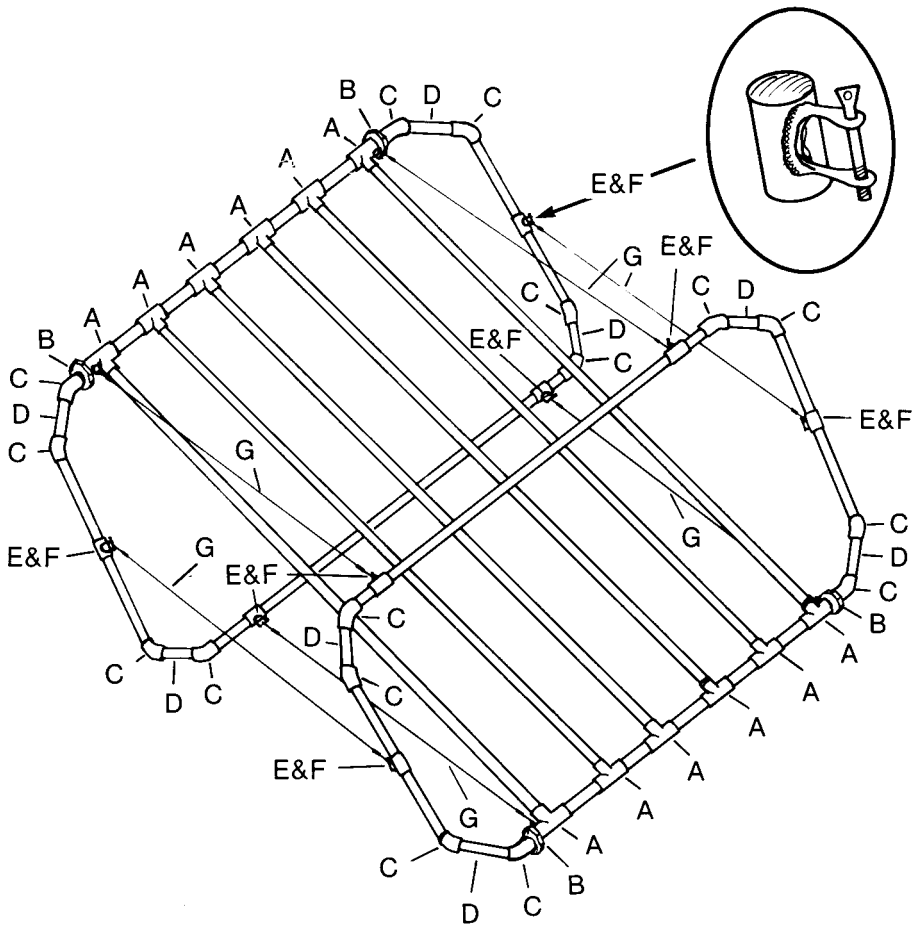

- A 3/8" GALVANIZED "T" FITTING
- B 3/8" UNION (WELDED TO A AND C)
- C 3/8" GALVANIZED 45° FITTING
- D 3/8" GALVANIZED NIPPLE
- E 3/8" GALVANIZED COUPLING
- F 3/16" SHACKLE (WELDED TO E)
- G 1/8" STAINLESS CABLE WITH 1/8" NICOPRESS SLEEVES

FIGURE 7. FITTING ASSEMBLY

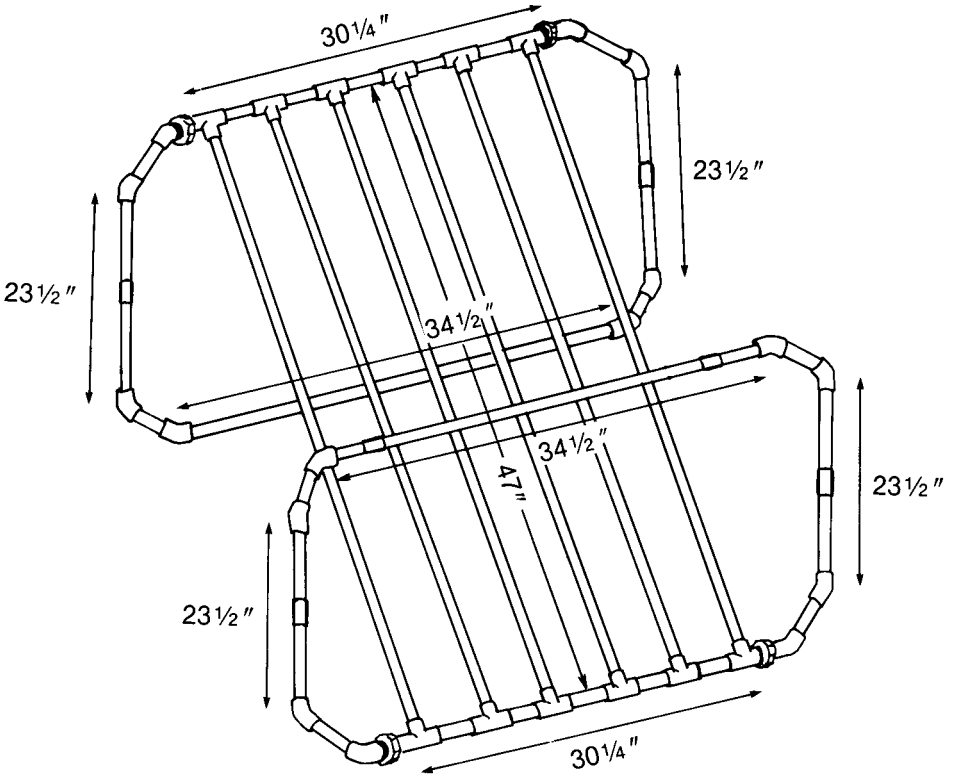

FIGURE 8.
COMPLETED FRAME

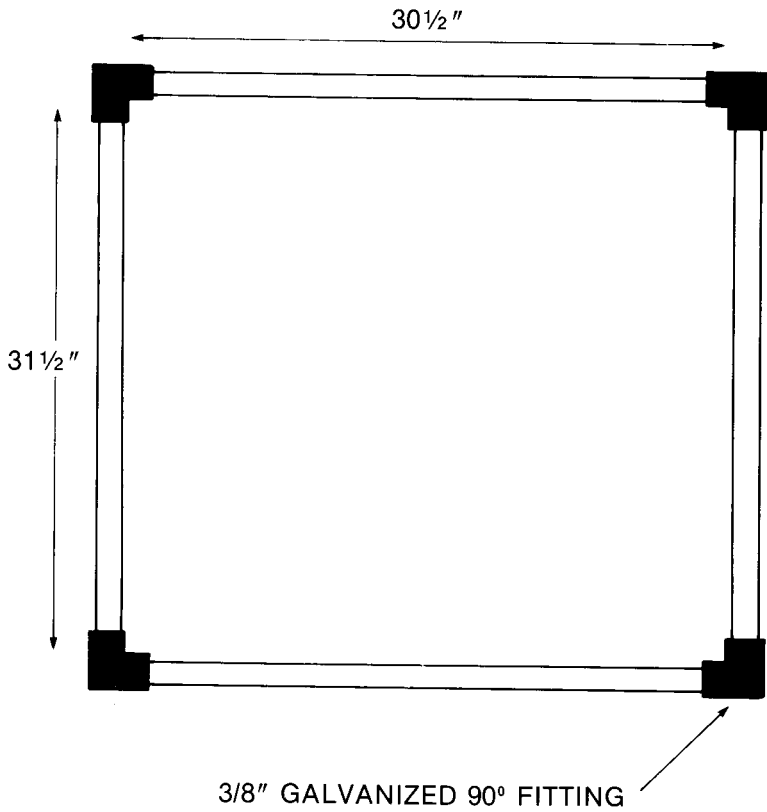

FIGURE 9.
DOOR FRAME ASSEMBLY

Fitting Dowel Assembly

1. After glue has dried, drill a 3/32-in. hole into each of the glued 45° and T fittings as shown in illustration.
2. Insert 3/32-in. stainless steel rod into 3/32-in. holes flush with opposite side (a hammer may be needed to tap it in) and cut 1/8 in. above the fitting.
3. With a metal surface underneath (metal plate, another hammer, etc.), brad the ends of each dowel with a hammer.
4. Center four (4) couplings on each side of both hoops in a position facing each other (shackle to shackle) on the inside of opposite hoops, then drill and dowel according to previous instructions.
5. Space couplings on top of front hoop and bottom of back hoop on 30-in. center (15 in. from center of rod). Make sure the shackles on the back hoop face the front hoop and vice versa, then drill and dowel each coupling.
6. Drill and dowel each 90° fitting on door frame.

Brace Cable Assembly

1. Brace device frame in an upright position using two (2) 36-in. sections of 5/8-in. fiberglass rod between front hoop and back hoop. Make sure the brace is against fiberglass rod on front hoop and back hoop (twine will be needed to hold the rods in place).
2. Cut the 1/8-in. stainless steel cable into six (6) 48-in. lengths.
3. Compress a 1-in. eye into one end of each of the 48-in long cables using oval nicopress sleeves.
4. Shackle four (4) cables to couplings on one hoop and shackle two (2) cables to couplings (opposite hinge assembly) on the second hoop.
5. Slide nicopress stop sleeve onto each cable.
6. Attach the free ends of two (2) side brace cables to shackles in the opposite hoop with nicopress oval sleeves, pull out all slack, then crimp oval sleeves approximately 1 in. from the shackle pins. Cut off excess cable.
7. Attach free end of top and bottom brace cables to union hinge with nicopress oval sleeves, take up all slack, then crimp 1/2 in. from fitting. Cut off excess cable.
8. Adjust union hinges to a minimum amount of play and tack weld the union nut to the threaded side (not the rotating side) of the union.

Construction of Finfish Deflector

The finfish deflector is used to increase bycatch reduction during daylight and nighttime fishing operations. The increased reduction is accomplished by diverting the fish out the side openings before they enter the cod end or bag.

Materials

1. Eleven (11) ft of 5/8-in. fiberglass rod.
 2. Eight (8) 3/8-in. galvanized 45° fittings.
 3. Two (2) 3/8-in. galvanized T fittings.
 4. Forty-four (44) ft of 1/16-in. stainless steel cable.
 5. Four (4) 1/16-in. nicopress oval sleeves.
 6. Three (3) ft of 1/4-in. shock cord.
 7. One (1) 3/32-in. x 3-ft stainless steel rod.
 8. One (1) 5/8-in. drill bit.
 9. One (1) kit of 3M No. 2216 epoxy glue.
 10. One (1) 3/32-in. drill bit.
- A. Preparation for Frame Construction:
1. Cut two (2) 22-3/4-in. sections of 5/8-in. fiberglass rod.
 2. Cut two (2) 15-1/2-in. sections of 5/8-in. fiberglass rod.
 3. Cut four (4) 5-3/4-in. sections of 5/8-in. fiberglass rod.
 4. Cut one (1) 24-in. section of 5/8-in. fiberglass rod.
 5. Drill threads from galvanized 45° fittings with 5/8-in. drill bit.
 6. Drill long side of T fitting completely through and drill threads from perpendicular hole on T fitting.

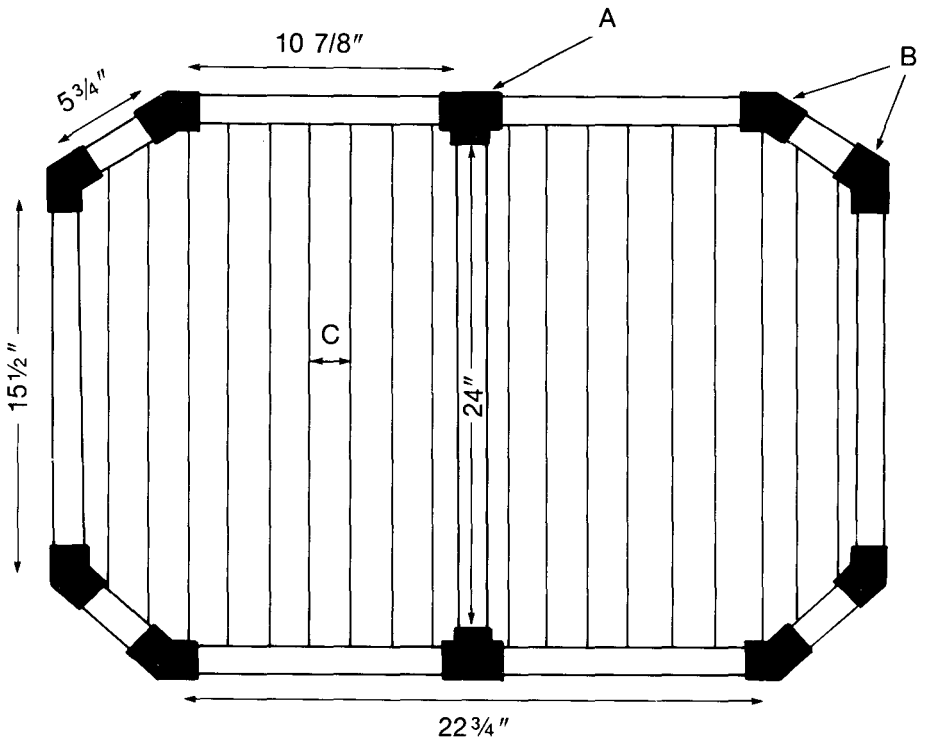

- A 3/8" GALVANIZED T FITTING
- B 3/8" GALVANIZED 45° FITTING
- C 1/16" 7x7 STRAND STAINLESS CABLE
CABLE SPACING 1 1/2" APART FROM
INSIDE CENTER "T" FITTING

FIGURE 10.
FINFISH DEFLECTOR ASSEMBLY

B. Deflector Frame Construction: (see figure 10)

NOTE: Work on flat surface to assure proper alignment of fittings.

1. Mix glue according to instructions.
2. Slide one (1) T fitting onto each 22-3/4-in. section of fiberglass rod, center and place a moderate amount of glue into the perpendicular hole of each T fitting.
3. Insert each end of the 24-in. section of fiberglass rod into glued perpendicular hole of T fitting.
4. Place a moderate amount of glue into each side of 45° fitting and slide onto one end of 22-3/4-in. section of rod.
5. Insert a 5-3/4-in. section of rod into the open hole on glued 45° fitting.
6. Place a moderate amount of glue into each end of a 45° fitting and slide over the opposite end of the 5-3/4-in. rod.
7. Insert the 15-1/2-in. section of fiberglass rod into open end of glued 45° fitting.
8. Place a moderate amount of glue into a 45° fitting and slide over the end of the 15-1/2-in. section of fiberglass rod.
9. Insert a second 5-3/4-in. section of fiberglass rod into the glued 45° fitting.
10. Place a moderate amount of glue into a 45° fitting and slide one side over the end of the 5-3/4-in. section of fiberglass rod; then slide the opposite side over the end of the 22-3/4-in. section of fiberglass rod, completing one side of the frame.
11. Repeat steps 4 through 11 to complete the second half of the frame.

C. Doweling Fittings: (after dry)

1. Drill a 3/32-in. hole through each side of the 45° fittings.
2. Drill a 3/32-in. hole through the long side and perpendicular side of each T fitting.
3. Insert a 3/32-in. stainless steel rod through 3/32-in. hole (a hammer may be needed to tap it in) flush with opposite side and cut 1/8 in. above the fitting.
4. With a metal surface underneath (metal plate, another hammer, etc.) brad the ends of each dowel with a hammer.

D. Cable Assembly:

1. With a 3/32-in. drill bit, drill holes every 1-1/2 in. through the top and bottom of the deflector frame starting 1-1/2 in. from the center brace bar.
2. Cut the 44-ft piece of 1/16-in. cable into two (2) equal lengths (22 ft).
3. Lace one (1) 22-ft section of cable through each side of the deflector frame.
4. Crimp the outside end of the cable to the deflector frame, take up all the slack in the cable and crimp the inside end of the cable to the deflector frame. Cut off excess. Repeat for the opposite side.

E. Installation of Finfish Deflector:

1. The deflector is installed in the TED by securing with two (2) 2-1/2-in. hose clamps to the top of the back hoop. Space the hose clamps 15 in. apart. (Important: Leave the hose clamps loose enough for the deflector to swing back and forth easily.)

2. A 3-ft section of 1/4-in. shock cord will be needed to hold the deflector parallel with the back hoop. Attach one end of the shock cord to the bottom of the center brace rod using a clove hitch. Starting at the deflector, measure 21 in. along the shock cord and attach to the center grid bar 26 in. down from the top of the back hoop. The shock cord allows the deflector to trip and spring back into position after loading with a sufficient amount of bycatch.

FINFISH DEFLECTOR ADJUSTMENT

- (1) SHOCK CORD LENGTH 3' (1/4")
- (2) SHOCK CORD TIED 26" DOWN CENTER BAR FROM TOP

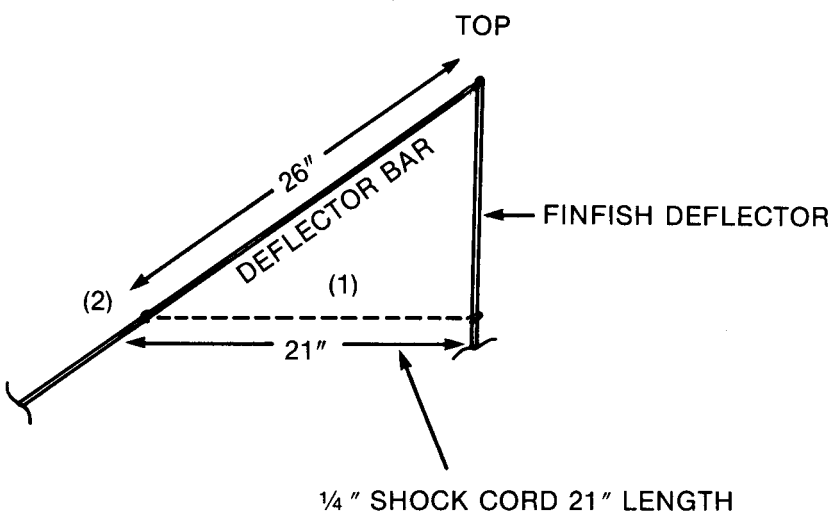

Installation Instructions

The TED is installed into a shrimp trawl by removing the cod end or bag from the trawl body and inserting the TED and its webbing extension between the trawl body and the cod end.

LIST OF MATERIALS

1. 120 x 120 mesh 1-3/4-in. No. 36 or No. 42 nylon bag webbing
 2. 25 x 80 mesh piece of 1-3/4-in. No. 36 nylon webbing
 3. 14 ft of 1/4-in. nylon backed shock cord
 4. 14 ft of 1/4-in. nylon rope
 5. Eight (8) 6 x 8 in. spongex floats
 6. 16 ft 3/8-in. polypropylene rope
 7. 36 ft 5/8-in. polypropylene rope
 8. 1 lb., No. 42 multiprolene twine
1. Cut a hole 25 meshes wide x 23 meshes deep in the top center of the 120 x 120 1-3/4-in. No. 36 or No. 42 nylon webbing extension, 23 meshes from the front of the extension. The cut out piece of webbing 22 x 24 meshes is laced to the device door with No. 42 twine using clove hitches (one mesh every 1-3/8 in.).
 2. Lace the 18th row of meshes (from the front of the extension to the front of the device) using a clove hitch every 4th mesh.
 3. Lace the 25 meshes of the back of the door opening to the back hoop between the union fittings (using a clove hitch every 1-3/16 in.). On the same row of meshes, lace the remainder of the extension meshes to the back hoop in the same manner as the front.
 4. Count 7 meshes forward from the back hoop and cut evenly 35 meshes from the door opening to the bottom brace wire. Turn and cut forward 12 meshes parallel to the bottom brace wire. Repeat for the opposite side (see Figures 12 & 13).
 5. Overlapping 2-1/2 meshes at the cut, lace the side door opening meshes to the top brace wires using an overhand knot on every mesh. Repeat for the opposite side.

6. Lace the bottom of the extension at the 12 mesh cut to the bottom brace wire using an overhand knot on every mesh. Repeat for the opposite side.
7. Unshackle the side brace wire and push the bottom of the side opening panel toward the grid bars and attach the 12 meshes along the bars in the bottom of the extension webbing, sewing one mesh to two bars. Repeat for the opposite side. Reshackle the side brace wire.
8. Attach the end of a 4-ft length of 1/4-in. shock cord to the first grid bar 8 in. from the top. Beginning with the 7th mesh from the top, lace the opposite end of the shock cord through the end mesh of the side opening until the bottom of the extension is reached. Then turn and lace in and out each mesh in the bottom of the extension until the back hoop is reached. Pull shock cord until all the slack is taken up in the side opening panel and secure it to the back hoop. Repeat for the opposite side.
9. Crimp the nicopress stop sleeves to the brace wires 9 in. from the back hoop.
10. Attach one end of a 4-ft length of 1/4-in. nylon rope to the top brace wire at the nicopress stop sleeve. Lace the opposite end through the end mesh on the outside panel of the side opening, pull out all slack and secure on the middle brace wire at nicopress stop sleeve. Continue down end meshes on the outside panel until the bottom brace wire is reached. Pull out all slack and secure to the bottom brace wire at the nicopress stop sleeve. Repeat for the opposite side.
11. Construct a funnel from a 25 x 80-mesh piece of predipped and stretched 1-3/4-in. nylon webbing by sewing the webbing together along the 25-mesh edge. A section of the funnel, 10 bars x 10 meshes x 10 bars, must be cut out of the bottom back center to allow the funnel to fit against the grid bars (see Figure 11).
12. The funnel is attached to the device extension on the second row of the meshes from the front of the extension before the extension is sewn to the trawl body.

The funnel is sewn to the device extension by doubling every other mesh on the extension to allow the 80-mesh funnel to fit evenly in the 120-mesh extension. After the funnel is sewn to the extension, a 5-ft section of 1/4-in. shock cord is laced through 25 meshes in the top back of the funnel. Over a 20-in. spacing in the middle of the shock cord secure to the shock cord the first and last mesh through which the shock cord passes. Space 6 in. from the first and last mesh secured and attach the ends of the shock cord to the outside grid bars 18 in. from the top back hoop. The shock cord on the funnel is used to hold the funnel in the correct position to direct water flow into the trawl bag or cod end (see Figure 12).

13. Cut a hole 9 meshes x 4 meshes between the middle and bottom brace wires two (2) meshes ahead of the front hoop. Lace a 3-ft length of 1/4-in. nylon rope through the end mesh of the hole and tie the ends of the rope together. Repeat for the opposite side.
14. Lace an 18-ft section of 5/8-in. polypropylene rope around the front hoop through previously laced meshes (every second mesh from center of frame to the top brace wire on each side). Do not lace between top brace wires. Repeat for the back hoop.
15. Tie two (2) 6 x 12-in. floats to the front hoop between the middle and top brace wire with a 4-ft section of 3/8-in. polypropylene rope. Repeat for the opposite side and back hoop.
16. Attach the door to the device by sewing evenly the front door opening meshes to the narrowest side of the door. On the metal TED secure the first four (4) meshes on the door frame to the top brace wire on each side. This allows the door to close automatically when the TED is pulled open into a fishing position. For the fiberglass TED, only three (3) meshes should be secured to the top brace wires (using clove hitches). (NOTE: The door should overlap the back hoop.)
17. Attach the device to the trawl by sewing the device extension to the trawl with the top center of the device in line with the top center of the trawl. The trawl cod end is then sewn to the tail of the device extension.

18. Twin trawl installation – If TED is to be installed in a twin trawl system, the installation must be modified slightly to prevent tangling of the two TED's required for the twin trawls. The TED's must be staggered to prevent the TED's from contacting each other during deployment and retrieval. Installation of the TED's into the twin trawls is the same as that described above except that the device extension which is sewn around the TED on the inside net of the twin rig (the net nearest the vessel), is reduced in length from 120 meshes to 90 meshes. The outside trawl device extension remains 120 meshes in length.

Handling Procedures

1. Setting out the TED – The TED should be set on the rail of the vessel at a 45° angle and the bag dropped over the side. After “breaking down” the trawl, the device should be held at the back allowing the trawl to pull the device out while steadying it so it does not roll over. After the device is out in an upright position, the trawl may be trailed out in the normal manner.
2. Retrieving the TED trawl – The trawl should be retrieved with the vessel headed into the seas to prevent catch in the bag from being washed into the device by following seas. The bag is retrieved and the catch dumped with the device remaining alongside the vessel.

FIGURE 11.
FUNNEL CONSTRUCTION

1 3/4" WEBBING

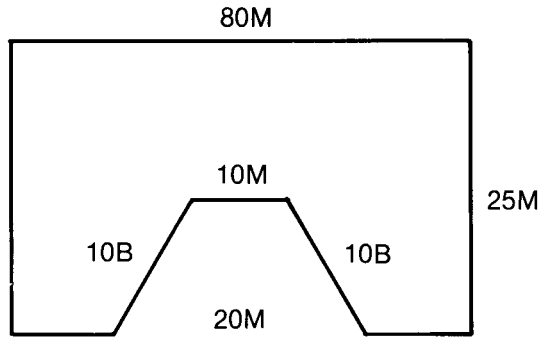
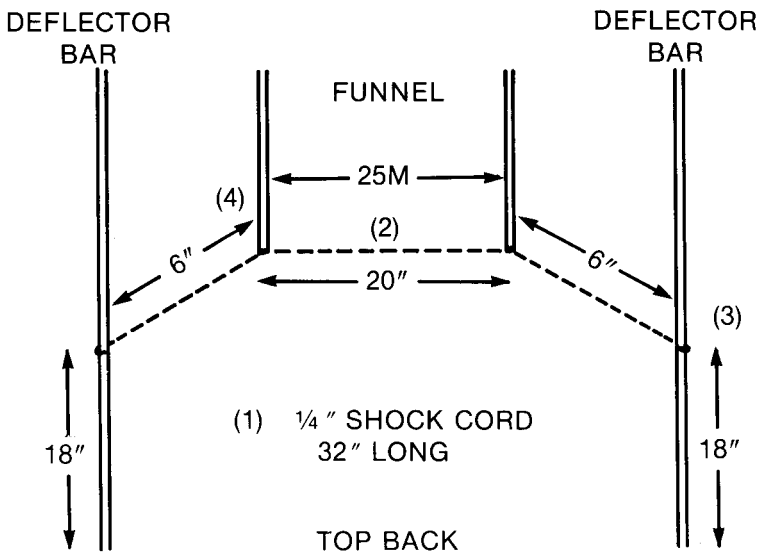

FIGURE 12.
FUNNEL RIGGING PROCEDURE



- (1) 1/4" DIA. SHOCK CORD 32" PLUS ENOUGH TO TIE OFF.
- (2) SHOCK CORD LACED THROUGH 25 MESHES IN FUNNEL TOP.
- (3) SHOCK CORD TIED TO OUTSIDE DEFLECTOR BARS 18" FROM TOP DEFLECTOR.
- (4) FUNNEL SECURED TO SHOCK CORD 6" FROM END.

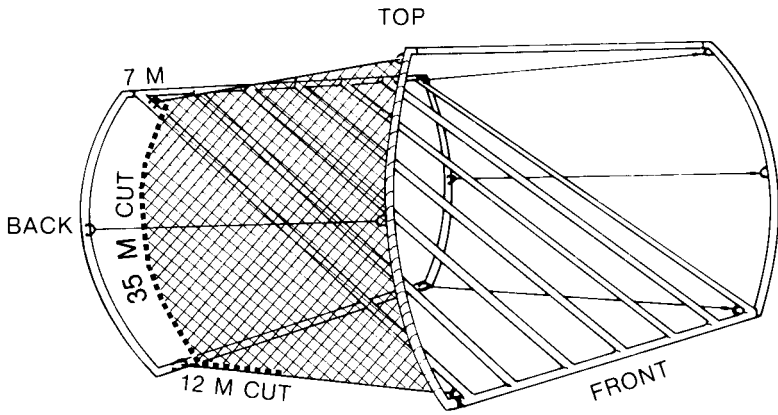

FIGURE 12. FINFISH SEPARATOR
(CUTTING PROCEDURE)

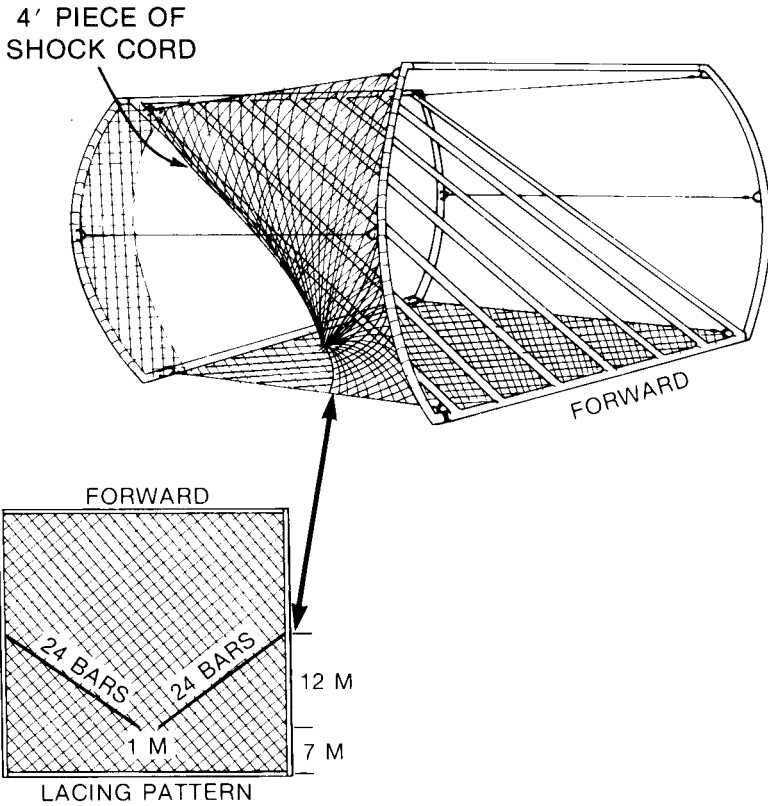

FIGURE 13. COMPLETED FINFISH SEPARATOR

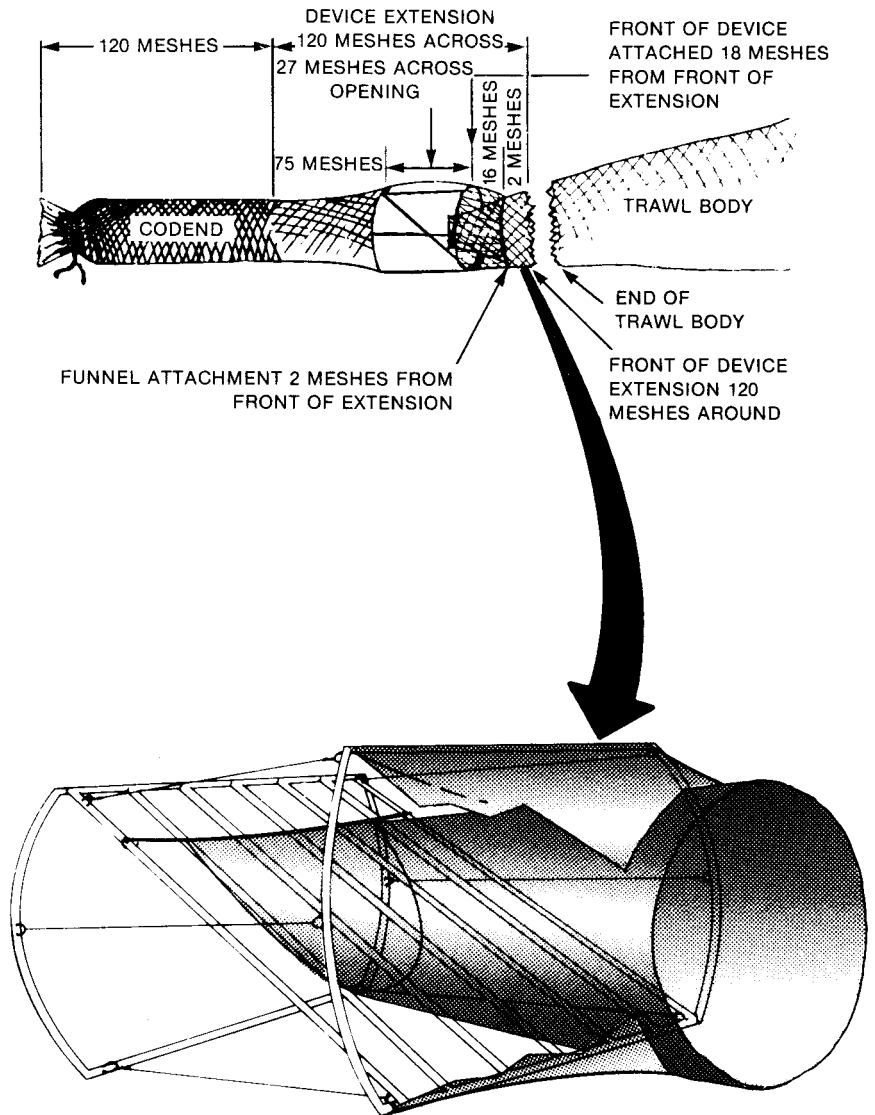

FIGURE 14. INSTALLATION INSTRUCTIONS